

*Hudson*

**DRIVE-MASTER  
SERVICE INFORMATION**



**HUDSON MOTOR CAR COMPANY**

**DETROIT 14, MICHIGAN**

**U. S. A.**



SECTION 10

HUDSON DRIVE-MASTER

— INDEX —

	Page		Page
DRIVE-MASTER UNITS . . . . .	2	Transmission Switch Plug . . . . .	8
Instrument Panel Switch . . . . .	2, 8, 16	Instrument Panel Switch . . . . .	8
Clutch Power Unit . . . . .	2	Linkage . . . . .	8
Accelerator Switch . . . . .	3, 17	Clutch Switch . . . . .	8
Transmission Power Unit . . . . .	3, 18	Transfer Switch . . . . .	9
Operating Linkage and Transfer Key . . . . .	4	Plugs and Sockets . . . . .	9
Transmission Control Switch			
Assembly . . . . .	4, 19, 20	TRANSFER KEY . . . . .	21
Transfer Switch . . . . .	5, 9	Removal and Installation . . . . .	21
Clutch Switch . . . . .	5, 8	TRANSMISSION CONTROL SWITCH . . . . .	20
Selector Switch . . . . .	5, 19	Removal and Installation . . . . .	20
Neutral and Limit Switches . . . . .	5, 19	TROUBLE SHOOTING . . . . .	12
Governor Switch . . . . .	6, 16	Starting Motor Will Not Operate . . . . .	12
DRIVE-MASTER ADJUSTMENTS . . . . .	10, 11	Transmission Remains in Neutral . . . . .	12
TRANSFER DIAPHRAGM . . . . .	20	Does Not Shift Into Second From	
Removal and Installation . . . . .	20	High . . . . .	13
DRIVE-MASTER SHIFT SHAFT AND/OR		Does Not Shift From Second to	
SHIFT SHAFT LEVERS . . . . .	21	Neutral . . . . .	13
Removal and Installation . . . . .	21	Does Not Shift Out of Second Into	
INSTRUMENT PANEL SWITCH . . . . .	22	High . . . . .	13
Removal and Installation . . . . .	22	Shift Incomplete - Stops in Neutral . . . . .	14
OPERATION . . . . .	2	Free-Wheels at Speeds Above 25	
POWER UNIT MOUNTING BRACKET . . . . .	21	MPH . . . . .	14
POWER UNIT SHIFT STRAP . . . . .	21	Throttle Remains Locked . . . . .	14
Removal and Installation . . . . .	21	Slow Release of Throttle Lock . . . . .	14
POWER UNIT TRANSFER DIAPHRAGM		Noisy Cross-over . . . . .	14
ENGAGING ROD AND/OR ROD END		Sticky Cross-over . . . . .	14
SLEEVE . . . . .	21	Squeak During Power Shift . . . . .	14
Removal and Installation . . . . .	21	Gears Clash During Shift . . . . .	14
POWER UNIT SOLENOID VALVES AND		UNIT CHECKS . . . . .	16
TRANSFER DIAPHRAGM REMOVAL . . . . .	20	Plug Check . . . . .	16
REFERENCES . . . . .	22	Instrument Panel Switch Check . . . . .	16
SERVICING THE DRIVE-MASTER . . . . .	22	Governor Switch . . . . .	16
Electrical Connections . . . . .	6	Throttle Lock Failure . . . . .	16
Clutch Control Solenoid . . . . .	7	Accelerator Switch . . . . .	17
Throttle Lock Solenoid . . . . .	7	Shift Rail Switch . . . . .	18
Transmission Switch Plug . . . . .	8	Vacumotive Clutch Solenoid . . . . .	18
Instrument Panel Switch . . . . .	8	Throttle Lock Solenoid . . . . .	18
Linkage . . . . .	8	Transmission Power Unit . . . . .	18
Clutch Switch . . . . .	8	Clutch and Transfer Switch . . . . .	19
Transfer Switch . . . . .	9	Selector Switch . . . . .	19
Plugs and Sockets . . . . .	9	Transmission Switch . . . . .	19
TRANSFER KEY . . . . .	21	WIRING DIAGRAM . . . . .	14
Removal and Installation . . . . .	21		
TRANSMISSION CONTROL SWITCH . . . . .	20		
Removal and Installation . . . . .	20		
TROUBLE SHOOTING . . . . .	12		
Starting Motor Will Not Operate . . . . .	12		
Transmission Remains in Neutral . . . . .	12		
Does Not Shift Into Second From			
High . . . . .	13		
Does Not Shift From Second to			
Neutral . . . . .	13		
Does Not Shift Out of Second Into			
High . . . . .	13		
Shift Incomplete - Stops in Neutral . . . . .	14		
Free-Wheels at Speeds Above 25			
MPH . . . . .	14		
Throttle Remains Locked . . . . .	14		
Slow Release of Throttle Lock . . . . .	14		
Noisy Cross-over . . . . .	14		
Sticky Cross-over . . . . .	14		
Squeak During Power Shift . . . . .	14		
Gears Clash During Shift . . . . .	14		
UNIT CHECKS . . . . .	16		
Plug Check . . . . .	16		
Instrument Panel Switch Check . . . . .	16		
Governor Switch . . . . .	16		
Throttle Lock Failure . . . . .	16		
Accelerator Switch . . . . .	17		
Shift Rail Switch . . . . .	18		
Vacumotive Clutch Solenoid . . . . .	18		
Throttle Lock Solenoid . . . . .	18		
Transmission Power Unit . . . . .	18		
Clutch and Transfer Switch . . . . .	19		
Selector Switch . . . . .	19		
Transmission Switch . . . . .	19		
WIRING DIAGRAM . . . . .	14		

## OPERATION

The Hudson car equipped with Drive-Master has the same controls as the conventional car and can be driven in exactly the same manner. The owner has the choice of three driving methods. Turning the control knob on the instrument panel to the left position provides automatic clutch operation with manual gear shifting. With the control knob turned to the right position, automatic clutch operation with automatic gear shifting in pick-up and high gear is obtained. With the control knob in the center or "off" position, manual operation of the clutch and shifting of gears is required and the car is driven in the conventional manner.

To Start, merely place the gear shift lever in high gear position, depress the accelerator pedal and the car moves forward in pick-up gear. When the car has reached the speed at which the driver desires to shift into high gear, he simply releases the accelerator pedal momentarily and the shift is made quickly and the car goes ahead in high gear. When coming to a stop, the transmission is automatically shifted from high to pick-up gear and the car is ready to start.

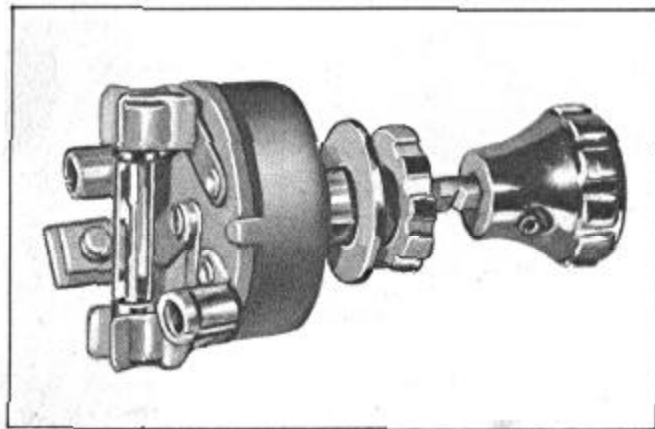

FIGURE 1

## DRIVE-MASTER UNITS

Hudson Drive-Master consists of the following units.

### INSTRUMENT PANEL SWITCH

The instrument panel switch Figure 1, controls Drive-Master operation and is used to select any of the three methods available to the driver of a car equipped with Hudson Drive-Master. It is mounted on the instrument panel just to the left of the lighting switch and contains a 10 ampere fuse to protect the Drive-Master units.

Turning the switch control knob to the left position provides automatic clutch operation with manual gear shifting. Turning the knob to the right position; automatic clutch operation and automatic gear shifting is obtained. With the switch in the center or "off" position Drive-Master is inoperative and the clutch operation and gear shifting are done manually in the conventional manner.

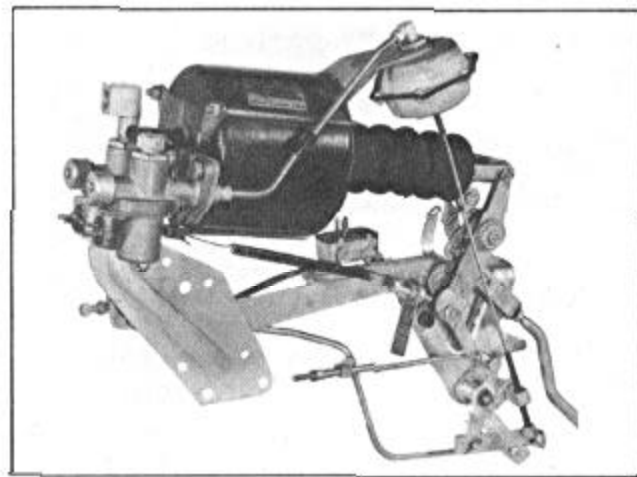

FIGURE 2

### CLUTCH POWER UNIT

The clutch power unit Figure 2, is mounted on the left side at the top of the engine. A vacuum line connects to the engine intake manifold to provide the power for operation.

The power is transmitted from the vacuum cylinder piston through a rod direct to the clutch throwout yoke shaft. The engaging and disengaging control is obtained through the accelerator switch and linkage connected with the accelerator pedal.

The unit used with the Drive-Master is identical with the mechanism used with Vacuotive Drive. It, however, is fitted with a throttle locking device which holds the throttle and the accelerator switch closed to prevent gear clash while the transmission shift is being made.

The throttle lock consists of a vacuum operated diaphragm connected to the accelerator linkage through a cable. Vacuum in the cylinder pulls up on the cable closing the throttle and holding the accelerator switch against the stop even if the accelerator pedal itself is pushed to the wide open position. A solenoid mounted beside the clutch control solenoid controls the vacuum to the throttle lock.

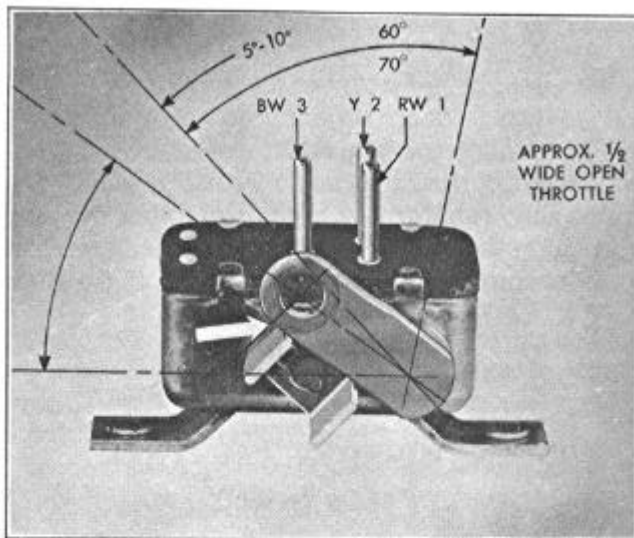

FIGURE 3

### ACCELERATOR SWITCH

The accelerator switch, Figure 3, used in conjunction with the Clutch Power Unit makes starting possible with wide open throttle for rapid acceleration.

When the foot is removed from the accelerator and the throttle is closed, the accelerator switch closes the electrical circuit through the clutch control solenoid, opening the vacuum valve and the clutch is disengaged.

Depressing the accelerator pedal opens the points of the accelerator switch permitting the clutch to re-engage.

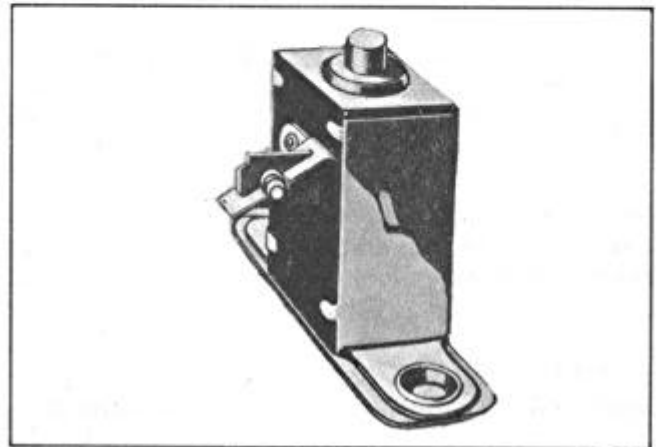

FIGURE 4

The shift rail switch, Figure 4, permits Automatic Clutch operation in low, second, or reverse gears regardless of car speeds. The shift rail switch is also used with Vacuotive Drive.

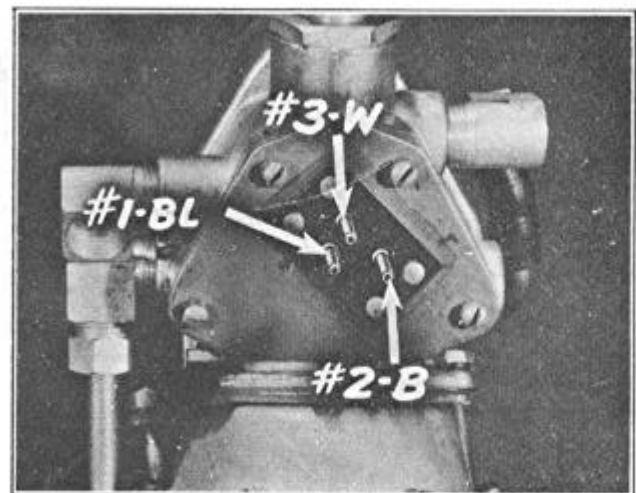

FIGURE 5

### TRANSMISSION POWER UNIT

The transmission power shifting unit, Figure 5, is made up of the transfer diaphragm

cylinder and the power cylinder together with the solenoid valves to control the transfer diaphragm and the movement of the piston in the power cylinder.

The power cylinder piston is connected to the piston rod, which in turn is connected through linkage to the power shift lever on the transmission. Both ends of the cylinder are closed except for the vacuum lines to the solenoid control valves.

The solenoid selector valve assembly is comprised of the transfer diaphragm solenoid, a second gear solenoid and a high gear solenoid.

If the solenoid valve controlling the rear end of the cylinder is energized, the valve opens to the vacuum line and the piston moves to the rear. This movement shifts the transmission into pickup gear.

If the solenoid valve controlling the forward end of the cylinder is energized, the piston is moved forward, shifting the transmission into high gear.

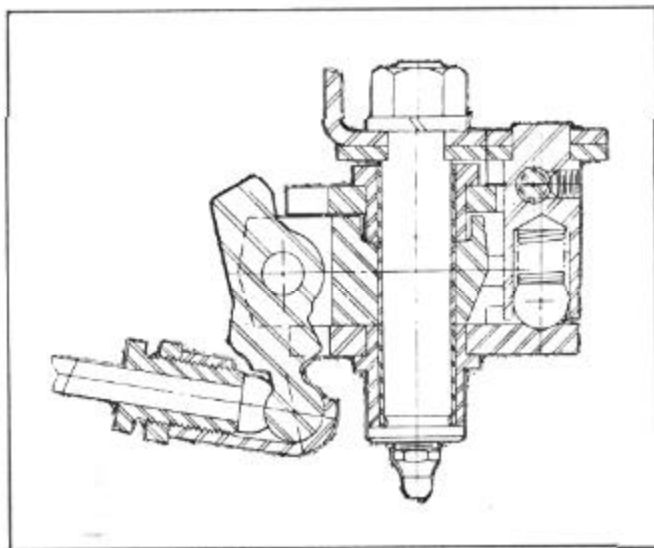

FIGURE 6

### OPERATING LINKAGE AND TRANSFER KEY

The movement for Manual or Power Shifting is transferred to the transmission lever through a rod from the transfer key lever, mounted on a stationary shaft at the rear of the power unit mounting bracket, Figure 6.

This shaft also carries the manual and power shifting levers, each provided with a notch for engagement with the transfer key.

Normally the transfer key is held in the manual shifting lever notch by spring pressure exerted on the transfer diaphragm rod. When the control knob on the instrument panel is turned to the right, electrical connections open the solenoid valve, admitting vacuum to the transfer diaphragm cylinder, turning the transfer key so that it engages in the notch of the power shift lever. This operation prepares the transmission for automatic or power shifting.

When the gear shift lever is moved to neutral and lifted through the "neutral gate" as required to make a shift to reverse or low, the circuit is broken to the solenoid operating the transfer diaphragm and the spring pressure behind the diaphragm turns the transfer key so that it re-engages in the manual shift lever notch. Low or reverse gear can then be shifted with the gear shift lever in the regular manner.

Returning the gearshift lever to neutral and dropping through the "neutral gate" again closes the transfer key circuit causing the key to engage the power shift lever notch. This again prepares the transmission for power shifting.

### TRANSMISSION CONTROL SWITCH ASSEMBLY

This switch box, Figure 7, bolted to the power unit bracket on the left side of the engine, contains the mechanically operated switches used to control the Drive-Master.

The switches contained in this unit are:

- (A) Transfer Switch
- (B) Clutch Switch
- (C) Selector Switch
- (D) Neutral and Limit Switch

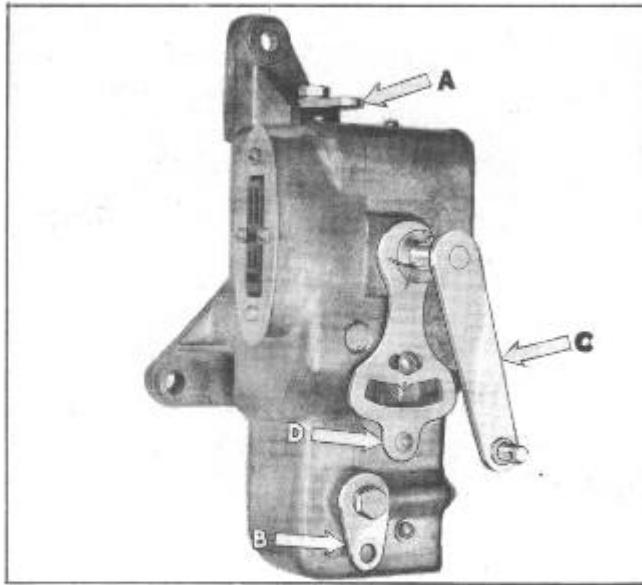

FIGURE 7

(A) **THE TRANSFER SWITCH**, Figure 7, is located at the top of the transmission switch and is operated by a non-adjustable link connected to the transmission cross shift selector lever.

The gear shift lever, when in neutral must return by means of its own return spring, to the second-high side when released from any position in the cross over. It must work free.

When the gear shift lever on the steering column is moved through the neutral or cross over to second-high side, the transfer switch lever is moved forward closing the switch points. This completes a circuit to the solenoid of the power unit, which controls the transfer diaphragm drawing the diaphragm back and connecting the power shift lever to the transmission shift lever through the transfer key.

When the gear shift lever is again moved to the low-reverse side, the transfer switch lever moves backward, opening the switch. The diaphragm spring moves the transfer key and linkage to disconnect the power shift lever and reconnect the manual shift thus preparing it for shifting into low or reverse.

(B) **THE CLUTCH SWITCH** is located at the bottom of the transmission switch housing. It is operated by a non-adjustable link connected to the clutch throwout shaft lever. When the clutch is disengaged the clutch switch lever is moved backward.

One set of points close to complete the circuit to the starter button.

A second set of points is closed completing the circuit to the selector, neutral and limit switches.

The clutch switch is open when the clutch is engaged, therefore, no current is used when the car is being driven in any gear speed.

(C) **THE SELECTOR SWITCH** lever is connected to the transmission manual shift lever by a non-adjustable rod. When the gear shift lever on the steering column is moved to second gear position, the selector switch lever closes the circuit to the power unit causing the power unit piston to move into second or pick-up gear position.

When the gear shift lever is moved to the high gear position, the selector switch lever closes the circuit to the governor, which automatically selects the pick-up or high gear.

When the gear shift lever is placed in neutral, the selector switch closes a circuit to the neutral switch.

(D) **THE NEUTRAL SWITCH AND LIMIT SWITCH**. Both neutral and limit switches are operated by the same lever. This lever is connected to the transmission power shifting lever by an adjustable rod.

The neutral switch has two sets of points, both of which are open when the transmission is in neutral. When the transmission gears are in pick-up or high gear position, one set of points are closed and the other open.

If neutral is selected on the gear shift lever and the transmission gears are in high gear position, the circuit then is from the neutral point on the selector switch to the closed points of the neutral switch and from there to the power unit solenoid which controls the shift forward to pick-up gear position. The piston then moves rearward shifting the gear out of high toward neutral. When the shift reaches the neutral position, the neutral switch points are open and the shift stops.

If the transmission gears are in pick-up position when neutral is selected the other set of points in the neutral switch are closed and complete the circuits to the power unit solenoid which controls forward movement of the power cylinder. As before, when the transmission reaches neutral, the neutral switch points are opened and the shift stops.

The limit switch also has two sets of points, but both are closed when the transmission is in neutral. One set of points are opened when the shift to high gear is completed and the other set of points open only when the shift to pick-up gear is completed.

The switch also completes the circuit to the throttle lock solenoid on the clutch control, thus preventing the throttle being opened until each shift is entirely completed.

## GOVERNOR SWITCH

The governor switch, Figure 8, is located on the rear of the transmission and operated by the speedometer drive gear.

The governor controls circuits in the clutch control unit and in the transmission power unit. The separate (R) terminal is used only with cars equipped with overdrive.

When the gear shift lever is in the high gear position, the circuit is completed from the selector switch to the #1 or "Y" terminal of the

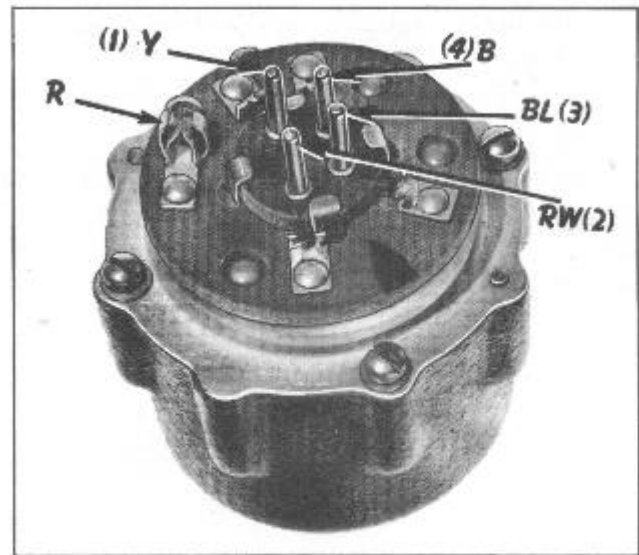

FIGURE 8

governor. At speeds below 9 to 13 miles per hour the points are closed to connect the #1 or "Y" terminal to #3 or "BL" terminal.

The #3 or "BL" terminal is connected with the transmission power unit so as to actuate the rear of the power cylinder and shifts into pick-up gear.

At speeds above 9 to 13 miles per hour the #1 or "Y" terminal is connected to the #4 or "B" terminal actuating the front of the power cylinder and the transmission is shifted into high gear.

## SERVICING THE DRIVE-MASTER

In the servicing of Drive-Master any units which the following tests prove to be faulty must be replaced in this entirety rather than to attempt internal repairs. This applies to the Clutch Unit and Solenoids, Power Shift Unit, and Solenoids, Transmission Switch, Governor Switch, Accelerator Switch, and Instrument Panel Switch.

As power for operating the Vacuum Clutch Unit and the power unit of the Drive-Master is obtained from engine vacuum, it is very important that engine performance be checked first when servicing the Drive-Master. The vacuum gauge should read from 19 to 21 to insure proper engine performance as well as correct Drive Master operation.



Before proceeding with checking other units of the Drive-Master it should be determined if Vacuum Drive or the automatic clutch control system is operating properly. This unit can be checked by turning the knob to the left on the instrument panel and operate the car shifting the gears manually. If this unit works as it should, that portion of the system can be eliminated from further checking.

**LEAKS IN THE VACUUM LINES** will cause sluggish operation or failure of the Drive-Master.

All vacuum line fittings should be checked and hose connections given particular attention. These are as follows:

1. Between clutch power unit and intake manifold.
2. Between clutch power unit solenoids.
3. Between throttle lock solenoids and diaphragm.
4. Between transmission power unit and air cleaner.
5. Between transmission and clutch power unit.
6. Between front of power cylinder and solenoid housing.
7. Between rear of power cylinder and solenoid housing.

**ELECTRICAL CONNECTIONS**

The battery should be in good condition and gravity not less than 1225.

**ALL TERMINAL CONNECTIONS** should be clean and in solid contact.

The important points to be checked are as follows:

1. Connector plugs on clutch power unit.

2. Connector plug on accelerator switch.
3. Power unit plug.
4. Transmission control switch plug.
5. Shift rail terminal.
6. Governor switch plug.

At this point it might be well to get acquainted with a few details that will be of help later in diagnosing service problems.

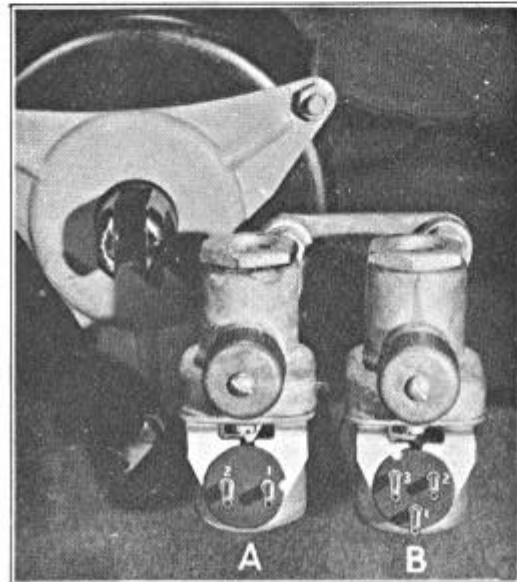

FIGURE 9

**CLUTCH CONTROL SOLENOID**

This solenoid (A), Figure 9, contains a single winding and each end is brought out to a terminal. The white wire (plug socket #1) is the hot wire from the instrument panel switch. The blue wire with two yellow tracers (plug socket #2) leads to the accelerator switch (plug socket #3).

**THROTTLE LOCK SOLENOID**

This solenoid (B), Figure 9, looks like the clutch control solenoid but the inside construction is different. This unit contains two windings. One end of each winding connects to a plug prong while the other end is grounded in the solenoid housing. One winding operates

the valve which applies the throttle lock when shift is being made to pick-up gear and the other when a shift is being made to high gear.

**NOTE:** The third prong is a marker only to prevent interchanging plugs.

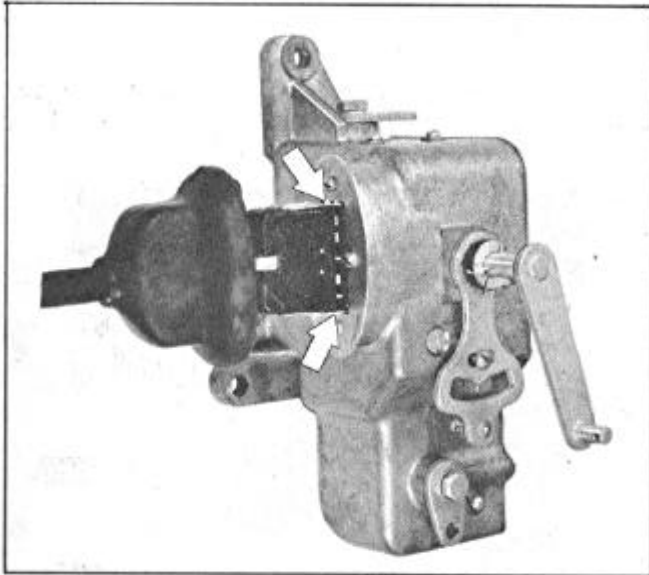

FIGURE 10

### TRANSMISSION SWITCH PLUG

This plug is held in place by clips, Figure 10. When replacing, be sure clips enter and engage behind the plug cover plate. The plug is released by pressing the clips together indicated by arrows.

**NOTE:** Be sure the boot is in place to keep water from entering the switch housing.

The prongs and sockets are silver coated to eliminate corrosion.

### INSTRUMENT PANEL SWITCH

Always determine that the instrument panel switch is on. A simple check can be made by moving the gear shift lever back and forth through neutral with the engine running. The transfer key can be heard operating.

### LINKAGE

While checking power unit wires and plugs, make sure all the rods and linkage are in place

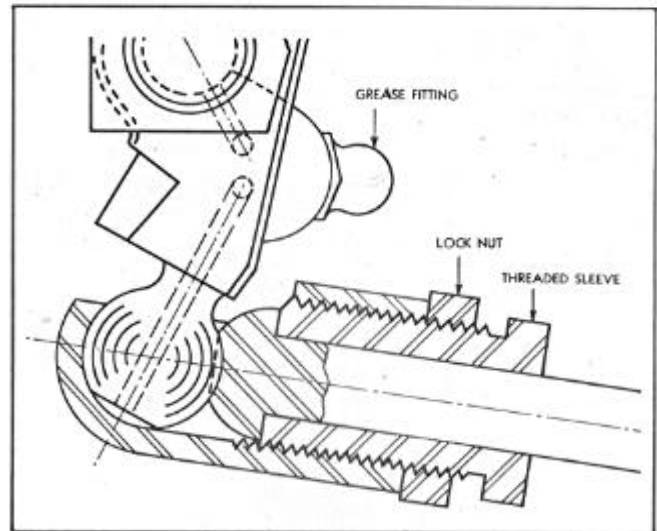

FIGURE 11

and properly connected and locked by their clips.

Recheck the ball and socket joint at the transfer key. This is a specially designed joint to permit adjustment without affecting clearance of the ball in the socket, Figure 11.

Adjustment is made by loosening the lock nut and turning the threaded sleeve inward so that it has no appreciable looseness and yet works free. Lubricate this joint and the transfer key pivot with viscous chassis lubricant through the fitting on the transfer key.

The accelerator linkage and the bell crank with the torsional spring assembly must work freely and should be well lubricated.

The accelerator switch lever must return solidly against the stop when the accelerator is released, otherwise, the clutch will not release and the Drive-Master cannot work, Figure 12. **This is Very Important.**

### CLUTCH SWITCH

Before checking the operation of the clutch switch, (housed in Transmission Switch Assembly), check clutch pedal lash. Clutch pedal must have 1-1/2" free play. With engine not operating, ignition switch turned on and start-

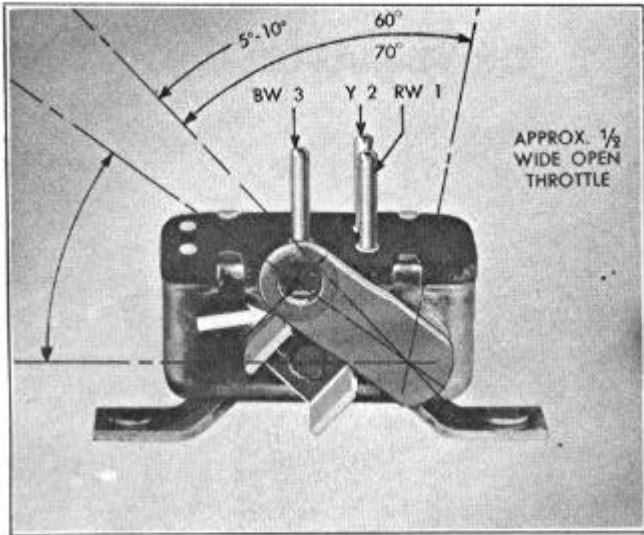

FIGURE 12

er button depressed, slowly push the clutch pedal down. The starter should operate before the pedal is within two inches of the toeboard.

### TRANSFER SWITCH

When the gear shift lever is in neutral, it must return to the second-high side when released from any position in the cross over by means of its own return spring. If it sticks, it will cause incomplete shifting, throttle locking, engine racing, etc. The hand gear shift lever must be on the second and high side at all times to energize the transfer cylinder and hold the transfer key engaged in the power shift lever.

Check the operation by moving the gear shift lever through the neutral cross over. The key should engage in the manual lever during the upper part of the movement and engage the power shift lever, during the lower half of the movement.

The preceding checks are general, but experience has shown that it is good practice to make these checks before attempting any changes or adjustments.

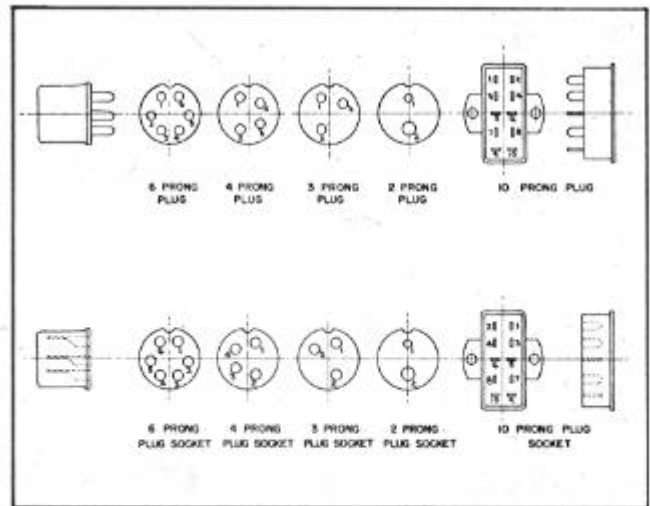

FIGURE 13

### PLUGS AND SOCKETS

In Figure 13 we show the various plugs and sockets used with wiring and the Drive-Master harness. As will be noted, all plugs are numbered in a counter-clockwise direction starting from the indentation on the outside of the plug. The mating sockets are numbered clockwise from the same starting point.

### DRIVE-MASTER TESTING EQUIPMENT

- One Test wire #16 - 40" long with 1/8" diameter test prod at one end and 1/2" clamp terminal at other end.
- One Jumper wire #16 - 24" long, one end with clamp 3/16", other end 1/2" clamp.
- One Test lamp with wires, one wire 28" long #16 with 1/8" diameter prod, other wire 84" long with 5/8" clamp terminal.
- One Transmission Control switch testing Harness KMO-670.
- One Allen set screw wrench 1/8".

The Vacuum Drive Unit should be functioning properly before using it in the Drive-Master combination. On Pages 10 and 11 we deal with the mechanical adjustments which should be checked as outlined under "Trouble Shooting" under the particular condition encountered.

DRIVE-MASTER ADJUSTMENT INSTR

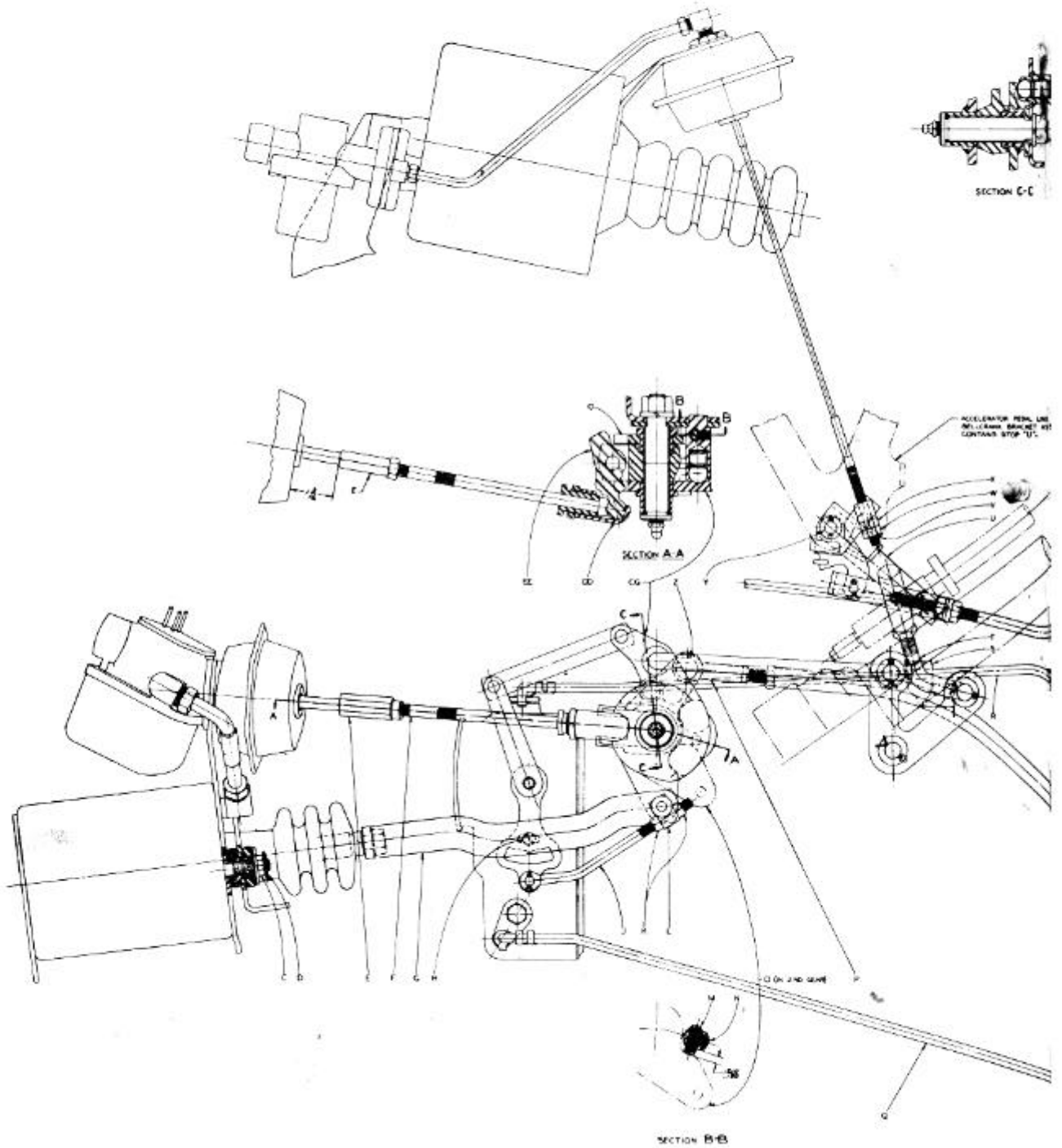
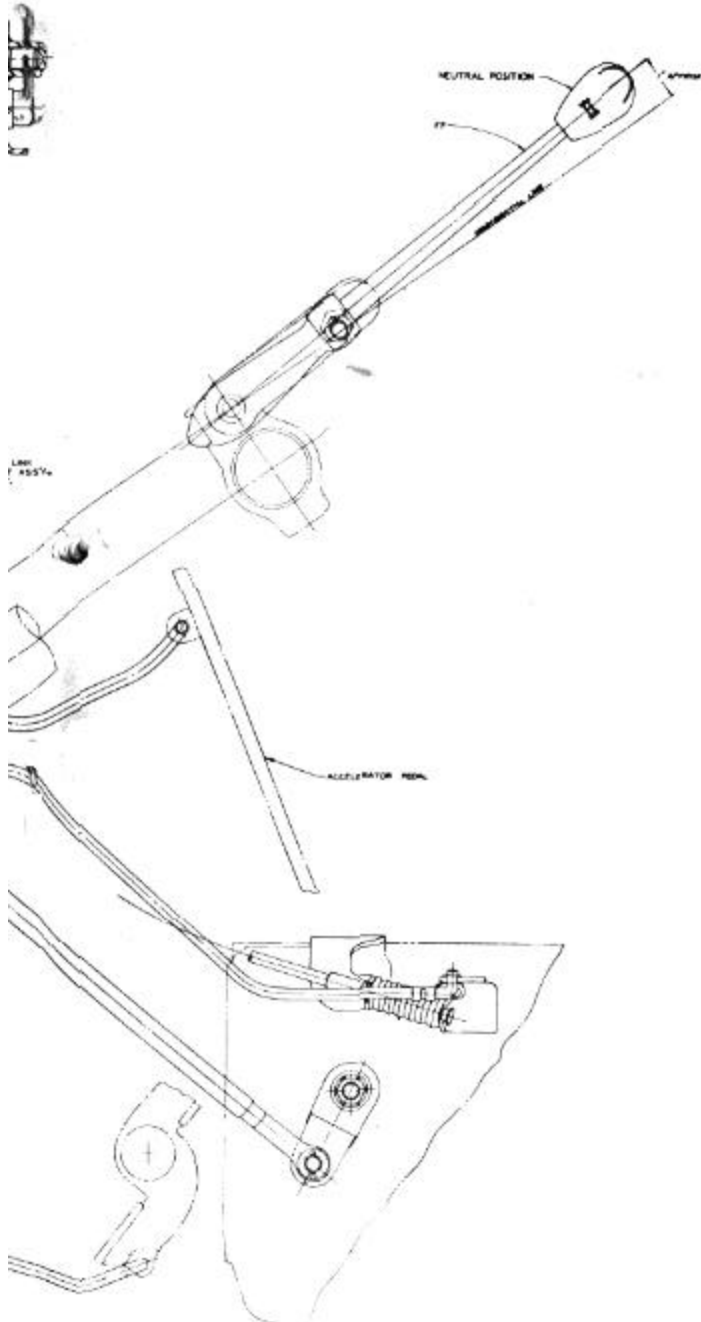

FIGURE 14

## INSTRUCTIONS



## ADJUSTMENT INSTRUCTIONS

1. Check adjustment of ball joint (DD) for free rotation without perceptible end play.
2. With lever (CC) in neutral, check rod (F) and adjustment if necessary to get 1-3/16" between front face of rod end (E) and rear face of diaphragm cylinder. See Section (A-A).

**CAUTION:** Loosen lock nut and hold diaphragm rod end (E) with a wrench to prevent rod from turning, which would damage the diaphragm, while turning rod (F) with pliers at the knurled surface.

3. With transmission in neutral, disconnect transmission shift rod assembly (P) at front end. Push or pull slightly on rod (P) until a free crossover is obtained. Jiggle lever (CC) until ball is seated solidly in neutral detent. Adjust length of rod (P) so that it can be reconnected without moving either of the levers to which it is attached. If crossover becomes stiffer when rod is connected, shorten or lengthen rod in 1/2 turn steps until crossover becomes free.
4. Adjust length of rod assembly (T) so that when in neutral the end of the hand lever (FF) is approximately 1" above a transverse horizontal line, as shown.
5. With engine running and HDM panel switch "on", shift to second gear. Turn stop screw (M) down until it contacts shift lever (O) and then turn it down 1/2 turn more. Lock in place with Allen head set screw (N).
6. With engine running, operate throttle lock by running a jumper wire from the battery negative post to either one of the throttle lock solenoid pins. Adjust nut (X) on diaphragm cable until lever (U) is held solidly against stop (V) when accelerator pedal is depressed. Lock nut with nut (W). Cable should not be so short that shaft (Y) is deflected when throttle lock operates.
7. Neutral switch adjustment:
  - (a) With HDM switch "on" and engine running, shift transmission to neutral, and disconnect shift rod (P) at front end.
  - (b) With shift rod (P) disconnected, move hand lever (FF) to second, and back to neutral.
  - (c) Push or pull slightly on rod (P) to obtain a free crossover in transmission.
  - (d) If shift rod (P) appears too short to go back on pin (Z), shorten neutral switch rod (J), if too long, lengthen neutral switch rod. Repeat (C), (D), and (E) until rod (P) can be reconnected without moving either of the levers to which it is attached.

**NOTE:** Do not change length of shift rod (P) as this length is determined by adjustment No. 3.

**FINAL CHECK:**

To eliminate sticky crossover, recheck adjustments No. 3 and No. 7. Also check to see that crossover switch rod (R) is centered in clip (S) at clutch housing.

**NOTE:** Transmission shift from second to high must take place between 9.5 and 14 M.P.H.

Transmission shift from high to second must take place between 9 and 12 M.P.H.

In high gear, Vacuum Drive must automatically become inoperative at a speed of 16 M.P.H. Min. to 21 M.P.H. Max. and remain inoperative at all higher speeds.

## TROUBLE SHOOTING

### CONDITION NO. 1

#### STARTING MOTOR WILL NOT OPERATE

- A. Check to see that clutch switch operating rod is connected at each end and that the rod operates the clutch switch lever mounted on the transmission control switch when the clutch pedal is pushed down.
- B. Remove the friction tape from wire splice about 6" to rear of power shift unit harness plug and run a jumper wire from this connection to small terminal on starting motor solenoid.
- C. If starter does not operate when starter button is pushed, trouble is in the regular starting circuit.
- D. If starter does operate, the trouble is in either the transmission control switch (Check J) or the wire harness.
- E. To check harness remove plug from transmission control switch. Start across plug prongs #9 and #10 while pressing the starter button.
- F. If starter does not operate, trouble is in harness.
- G. If starter operates, troubles is in transmission control switch (Check J).
- H. To check the switch remove the ten contact plug and connect to a spare transmission control switch held in hand.
- I. If the harness is OK, starter should operate when starter button is pushed and clutch switch lever on spare switch is turned in the clockwise direction.

**NOTE:** Position of other levers is unimportant.

- J. If starter operates, see transmission control switch test (Check J).

### CONDITION NO. 2

#### TRANSMISSION REMAINS IN NEUTRAL

With engine running, car standing and gear shift lever in high gear position.

**NOTE:** It is assumed starter operates; if not, see condition #1. Also that clutch disengages and engages. (If not, see "Vacumotive Drive Clutch Trouble Shooting Chart").

- A. Place shifting lever in second gear position.
- B. If transmission shifts to second gear, connect #1 and #3 sockets at governor wire harness plug with a short jumper wire.
- C. If transmission shifts from neutral to second either the governor wire harness plug (Check A) or the governor (Check C) is defective.
- D. If shift does not occur, either the wire harness or the transmission control switch is faulty (Make Checks A and J) before replacing switch or harness.
- E. Lift gear shaft lever through cross-over and return.
- F. If transfer diaphragm does not work, make the following checks:
 

See that transfer switch rod is properly connected to operate switch.

With engine idling, attach jumper wire from negative battery post to #3 pin on power unit.
- G. If transfer key does not operate, check for vacuum line to power unit leaks and for defective solenoid or ruptured diaphragm.
- H. If it does operate, connect test lamp between ground and #3 socket of plug at power unit.
- I. If lamp lights, plug is at fault (Check A).

- J. If lamp does not light, remove ten prong plug from transmission control switch.

With test lamp connected from negative battery terminal to the #3 socket of plug at power unit, ground #1 prong of ten prong plug.

- K. If lamp does not light, white wire in harness is broken or improperly soldered to plugs.
- L. If lamp lights, check transmission control switch (Check J).

Move gear shift lever from neutral to second while watching power unit.

- M. If power shift cylinder does not work, make the following check:

With engine idling touch jumper wire from negative battery post to #1 and #2 pin alternately; power cylinder piston rod should move "out" and "in".

- N. If it does not, check for air leaks in vacuum lines to each end of cylinder. Also check for defective second gear solenoid (Check I).

With gear shift still in second gear connect test lamp between ground and #1 socket of plug.

- O. If lamp lights, plug is at fault.
- P. If lamp does not light, replace transmission control switch (Check J).

### CONDITION NO. 3

#### DOES NOT SHIFT INTO SECOND FROM HIGH

- A. If transmission shifts from neutral to second, but not from high to second; make sure that binding or sticking throttle linkage is not causing the clutch to fail to disengage.
- B. If clutch disengages but transmission stays in high gear, make (Check C) and check governor wire harness plug (Check A).

### CONDITION NO. 4

#### DOES NOT SHIFT OUT OF SECOND INTO NEUTRAL

If transmission does not shift out of second and into neutral, make the following check:

- A. With engine idling, attach jumper wire from negative battery post to #2 pin on power unit solenoids. Power cylinder rod should move "in".
- B. If it does not, check for air leaks in lines to end of cylinder. Also check for defective high gear solenoid (Check I).
- C. With gear shift lever in neutral, connect test lamp between ground and #2 socket of power unit plug.
- D. If lamp lights, plug is at fault (Check A).
- E. If lamp does not light, fault is in transmission control switch (Check J).

### CONDITION NO. 5

#### DOES NOT SHIFT OUT OF SECOND INTO HIGH

- A. Remove four contact plug from governor and install jumper wire between #1 and #4 socket contacts in plug. Start engine and shift lever to automatic (high) positions while holding the clutch pedal down lightly with foot. Shift to high gear will be indicated by an increase in pressure on foot caused by the de-energizing of the Vacuum Drive Power Unit.
- B. If shift to high gear does occur, either the wire harness plug at the governor (Check A) or the governor itself (Check C) is faulty.

**WARNING: Set brakes and do not remove foot from clutch pedal during this check.**

- C. If shift to high gear does not occur, check wire between governor socket #4 and power shift unit plug socket #2 for an open circuit, also check both plugs (Check A).

### CONDITION NO. 6

#### SHIFT INCOMPLETE - STOPS IN NEUTRAL

Make (Check D).

### CONDITION NO. 7

#### FREE WHEELS AT SPEEDS ABOVE 25 M.P.H.

- A. If free wheeling never continues for more than 2 or 3 seconds, check spring behind gear shift lock detent. See Section GG in Figure 14. This should be a 30 lb. spring, (Part No. 41236).
- B. If free wheeling continues more than 2 or 3 seconds, make (Check C) and see "Vacumotive Drive Trouble Shooting, Condition No. 3".

### CONDITION NO. 8

#### THROTTLE REMAINS LOCKED

**NOTE:** A locked throttle indicates an incomplete shift.

- A. If locking occurs when shifting from second to neutral, make checks for failure to shift from second to neutral.
- B. If locking occurs on some other shift, check accordingly.
- C. Follow with (Checks D, E and F) in order. Also check "Vacumotive Drive Adjustments" No. 4 and 6.

### CONDITION NO. 9

#### SLOW RELEASE OF THROTTLE LOCK

In cold weather too heavy of a lubricant in the transmission will result in slow shifting causing the throttle to remain locked for a longer period of time. Refer to "Lubrication Section" for proper seasonal transmission lubrication instructions.

### CONDITION NO. 10

#### NOISY CROSS-OVER

This is due to looseness in the transfer diaphragm rod ball joint. See "Adjustment Chart", Items No. 1 and 2.

### CONDITION NO. 11

#### STICKY CROSS-OVER

See "Adjustment Chart", Items No. 3 and 7.

### CONDITION NO. 12

#### SQUEAK DURING POWER SHIFT

Check for damaged grommet on throttle lock diaphragm housing.

### CONDITION NO. 13

#### GEARS CLASH DURING SHIFT

Make (Check D).

### WIRING DIAGRAM

Referring to the HDM Wiring Diagram (Schematic) Figure 15, following the wiring in the Transmission Switch, we come to a resistance (zig-zag line connecting to Socket #1. Full voltage is applied on the diaphragm solenoid only when the clutch is closed (clutch disengaged).

**NOTE:** To prove the electrical circuits in any of the Drive-Master units, including Vacumotive Drive, use a test lite and jumper wire to make any of the following tests and replace units or repair if they do not check.



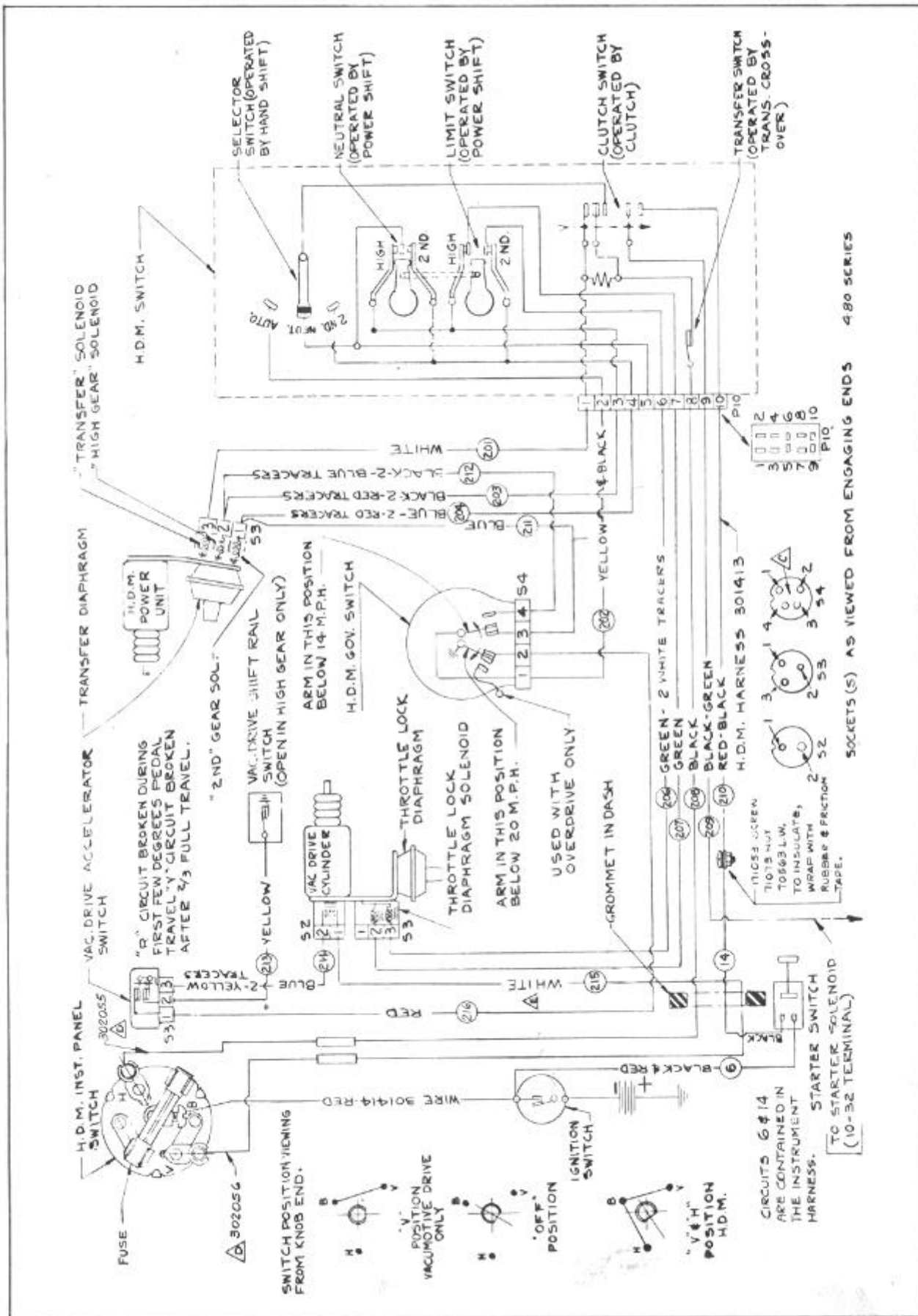

FIGURE 15

## UNIT CHECKS

### A. PLUG CHECK

Insert a 1/8" diameter rod successively into each socket of plug for a distance of 1/4". Socket should grip rod tightly enough to make a good electrical contact.

Use a 5/32" diameter rod in No. 2 socket of Vacuumotive Drive Solenoid.

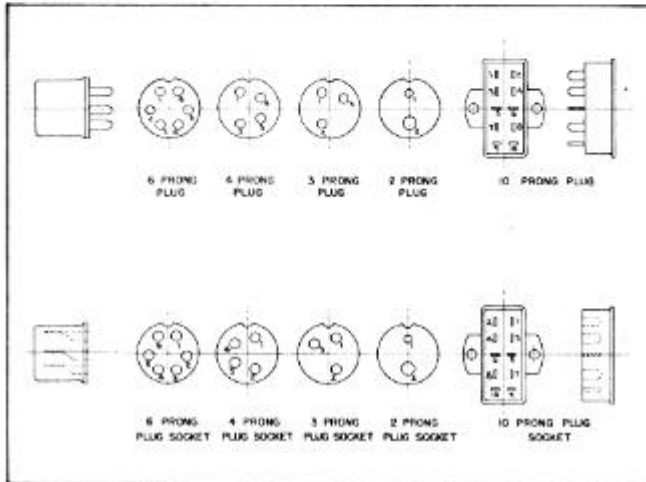

FIGURE 16

### B. INSTRUMENT PANEL SWITCH CHECK

Ignition Switch on. Ground long lead of test lamp. Switch button turned to DRIVE-MASTER SIDE (Right Side). Examine fuse and if fuse is OK, test lamp prod to No. 2 or No. 3 terminal Figure 17 should light test lamp.

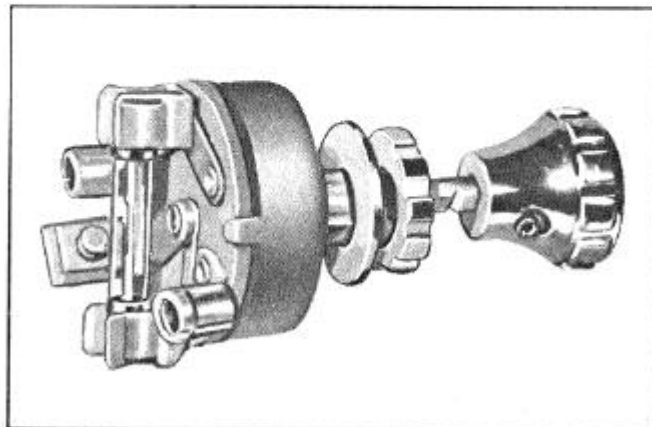

FIGURE 17

### C. GOVERNOR SWITCH

Rear wheels on stands. Start engine, shift to high gear. Remove connector plug. Long lead to test lamp to negative terminal of battery. Test lamp prod to #2 prong of governor Figure 18 should light test lamp when clutch is disengaged and also when clutch is engaged up to 16 to 21 miles per hour.

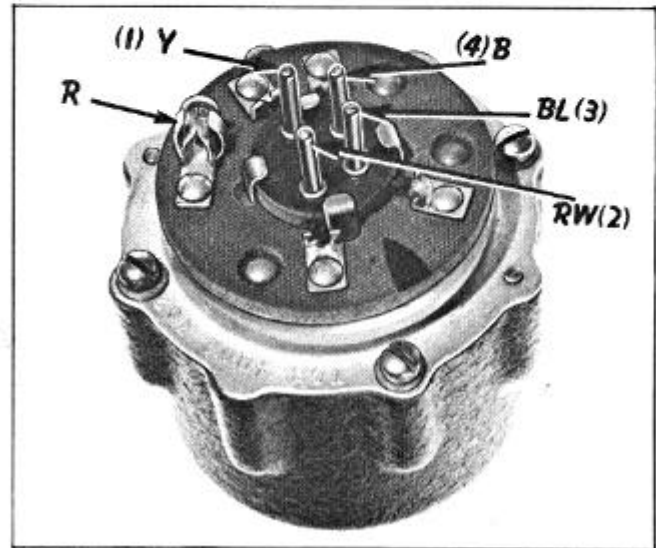

FIGURE 18

Ground #1 prong of governor, test lamp prod to #3 prong should light test lamp up to 9 13 miles per hour, above that speed with test prod to #4 prong should light test lamp.

A separate terminal for use with over-drive should light test lamp at speeds of 16 to 21 miles per hour and remain lighted at higher speeds.

### D. THROTTLE LOCK FAILURE

It is the function of the throttle lock to hold the throttle closed until a shift is complete. Failure to shift through neutral and clashing gears when accelerator pedal is pushed down again immediately after releasing is a sign of defective throttle lock.

**To check proceed as follows:**

With engine idling and H.D.M. turned on, shift from neutral to second, throttle should lock momentarily. Next shift from second back

to neutral, throttle should again lock momentarily. If proceeding checks were OK put transmission in second gear by pulling the hand lever down into automatic (high) position. Stop engine, pull plug connector from shifter unit, start engine and move hand lever to neutral. Throttle should lock. Jack up rear wheels and push accelerator down to floor while holding foot lightly on clutch pedal to stop it if clutch control should release suddenly.

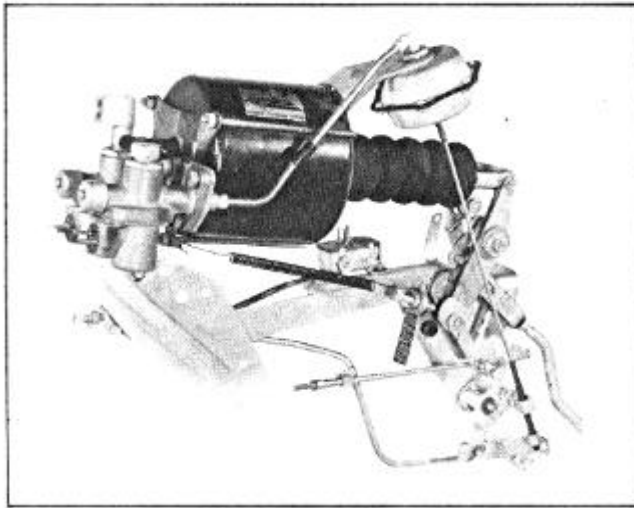

FIGURE 19

Throttle lock should hold engine at idling speed while accelerator pedal is at floor. If it does not, adjust cable length (Adjustment Instruction #6). If this adjustment does not stop pedal from breaking through throttle lock, check adjustment #8 and #11 of Vacuum Drive Adjustment Instructions. If these adjustments fail to correct trouble, change transmission control switch.

If throttle failed to lock on either the shift into or out of second, check as follows:

With engine idling attach jumper wire from negative battery post successively to each of the three throttle lock solenoids. Lock should operate in each case. If it does not operate, check for defective solenoid, ruptured diaphragm, or defective throttle lock ground wire.

If it does operate, adjust length of cable per adjustment instructions. Also connect test lamp successively between ground and #2 and #3 sockets in harness plug. In each case lamp should flash when gear shift lever is moved from neutral to second and back to neutral. If lamp flashes in both cases, plug is at fault. Make (Check A). If lamp does not flash in both cases, replace transmission control switch, (Check J).

If lamp does not flash in both cases, replace transmission control switch (Check J) or harness from plug socket #2 at throttle lock to #7 prong at ten prong plug and from #3 prong of plug at throttle lock to #8 prong of ten prong plug.

### E. ACCELERATOR SWITCH

Ground one lead of jumper wire, other lead to #2 prong of accelerator switch, figure 20, long lead of test lamp to negative terminal of battery. Lever against stop, test lamp prod to #1 prong of accelerator switch, should light test lamp. Moving lever 10 degrees from stop, light should go out. Lever against stop, test lamp prod to #3 prong, should light test lamp. Moving lever 60 to 70 degrees from stop, light should go out.

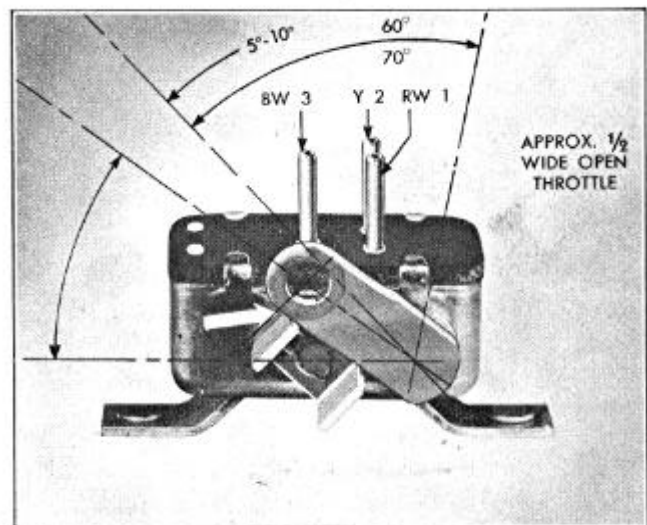

FIGURE 20

## F. SHIFT RAIL SWITCH

Stop engine, long lead of test lamp to negative terminal of battery. Prod of test lamp #2 socket of accelerator switch. Shift handy shift. No light on high gear, lamp lights on all others. Replace connector socket.

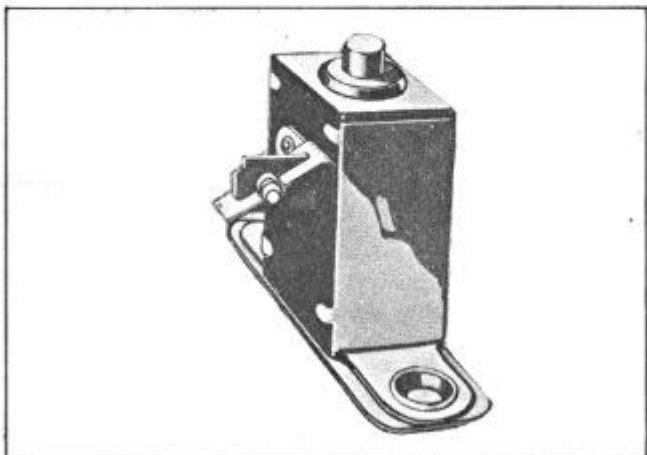

FIGURE 21

## G. VACUMOTIVE CLUTCH SOLENOID

Remove connector socket. Ground one lead of jumper wire, other lead to #2 prong of CVC solenoid, Figure 22 indicated by arrow. Connect one lead of a second jumper wire to negative terminal of battery to #1 prong of CVC solenoid, valve should operate. Replace connector socket.

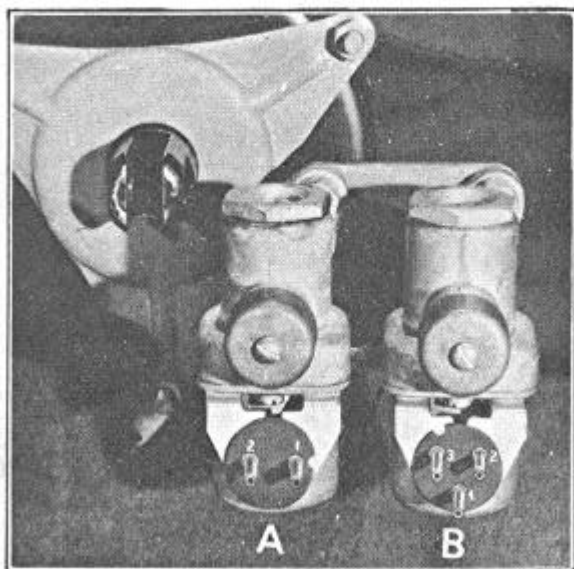

FIGURE 22

## H. THROTTLE LOCK SOLENOID

Remove connector. One lead of jumper wire to negative terminal of battery. Other lead to #2 prong of throttle lock solenoid, Figure 23, indicated by arrow valve should operate. Move jumper wire from #2 prong to #3 prong, valve should operate. Replace connector socket.

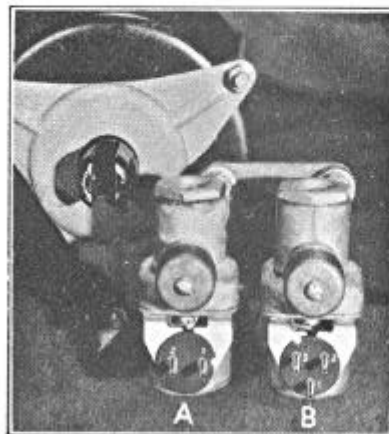

FIGURE 23

## I. TRANSMISSION POWER UNIT

Start engine. Remove connector socket. Lead of jumper wire to negative terminal of battery. Other lead to #1 prong of power unit. Piston rod should move "out". To #2 prong piston rod should move "in". To #3 prong should operate transfer diaphragm. Replace connector socket.

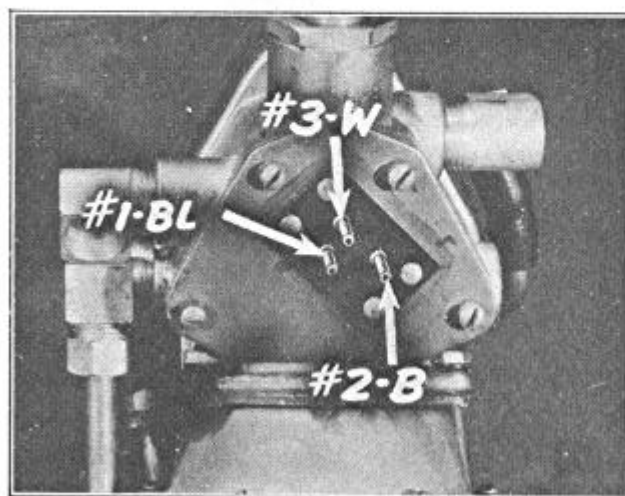

FIGURE 24

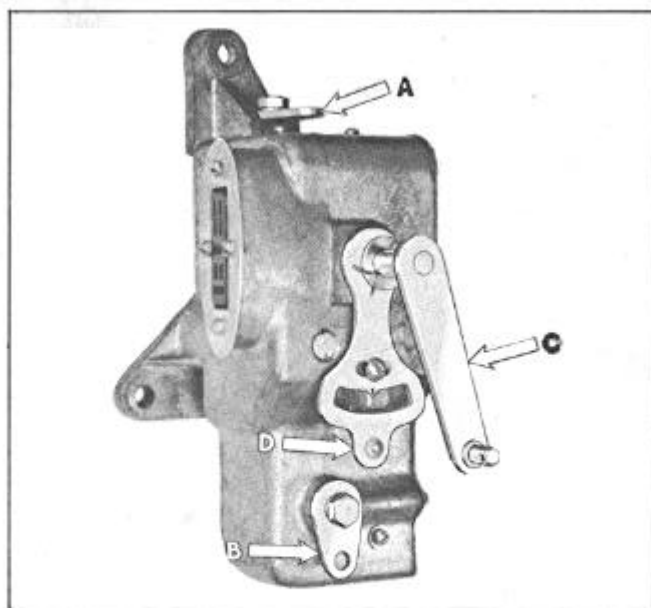

FIGURE 25

### J. TRANSMISSION SWITCH

Place handy shift in neutral. Remove connector plug. Insert plug of test harness. Long lead of test lamp to negative terminal of battery. Test lamp prod free for testing.

		Test Lamp from battery to Prong #	Ground lead to Prong	Lamp Lights
<b>(A)</b> Clutch and Transfer Switch	Disconnect clutch operating rod.	8	1	Yes*
	Move switch lever to rear (on).	8	5	Yes
	Gear shift lever in neutral.	9	10	Yes
<b>(B)</b> Selector Switch	Clutch switch on.	1	4	Yes
	1. - Move handy shift to second gear.	1	5	No
	Neutral switch in neutral	1	2	No
	2. - Move handy shift to neutral.	1	5	Yes
	Neutral switch in neutral.	1	2	No
		1	4	No
<b>(C)</b> Neutral and Limit Switch	1. - Move power lever to neutral (center). Gear shift lever in neutral.	1	2	Yes
		1	4	No
		1	5	No
		1	7	Yes
	2. - Move power lever to second (forward). Gear shift lever in neutral.	3	5	No**
		4	5	No**
		4	6	Yes
		4	5	No
	3. - Move power lever to high (rear). Gear shift lever in neutral.	3	7	No
3		5	No	
4		6	Yes	
4		5	Yes	

Remove test harness and replace plug.

\* When clutch switch is moved forward (off) the lamp should burn dim, and brighten when lever is moved to rear (on).

\*\* If lamp lights, recheck neutral switch adjustment, before proceeding further.

## DRIVE-MASTER POWER CYLINDER AND TRANSFER DIAPHRAGM

### REMOVAL

1. Disconnect diaphragm engaging rod (F) from rod end (E).
2. Disconnect shift strap (G) by removing bolt attaching strap to power cylinder.
3. Disconnect battery cables, battery hold down, battery, battery tray, and battery support (held by 3 screws).
4. Disconnect vacuum lines at transfer diaphragm solenoids.
5. Remove two cotter pins, nuts, ferrules, flat washers, and rubber bushings attaching the power cylinder to power cylinder support bracket and remove power cylinder and transfer diaphragm.

### INSTALLATION

1. Place complete unit in position and enter mounting studs with flat rubber bushings inserted between power cylinder support bracket and mounting bracket.
2. Install two bushings (with collar) over studs and through holes of mounting bracket and install brass ferrules over studs with flanged ends of ferrules entered in counter-bore of the rubber bushings.
3. Install flat washers, nuts, and cotter pins. Tighten nuts sufficiently to enter cotter pins, then back off nuts until face of nut touches cotter pin.
4. Attach power cylinder shift strap and transfer diaphragm engaging rod. (Adjust engaging rod to obtain 1-3/16" between front face of rod end (E) and rear face of diaphragm).

**NOTE:** Hold diaphragm rod (E) with a wrench to prevent rod from turning and damaging the diaphragm.

5. Adjust sleeve nut so that joint is loose on transfer key ball without any appreciable end play.
6. Connect vacuum lines at diaphragm.
7. Install battery support, tray, battery, battery hold down, and battery cables.
8. Recheck operation of unit and adjust as necessary.

## POWER UNIT SOLENOID VALVES AND TRANSFER DIAPHRAGM

### REMOVAL

**NOTE:** Use same procedure as outlined in "Power Cylinder and Transfer Diaphragm Removal and Installation" and remove transfer diaphragm unit from power unit on bench by removing the transfer diaphragm attaching screws.

**NOTE:** The solenoid valves are not serviced separately.

## TRANSMISSION CONTROL SWITCH

### REMOVAL

1. Lift off distributor cap.
2. Disconnect coil wire at distributor vacuum control tube, distributor attaching screw and remove distributor (6 cylinder only).
3. Disconnect clutch operating rod, transfer switch rod, neutral and limit switch rod and selector switch rod.
4. Remove one bolt, lockwasher and nut attaching transmission switch to support bracket at top and one bolt, lockwasher and nut at bottom and remove transmission switch.

### INSTALLATION:

Reverse procedure of removal, attaching upper bolt first. Make sure all cotter pins have been locked securely. Check adjustment and engine timing.

## POWER UNIT MOUNTING BRACKET REMOVAL

**NOTE:** The power unit mounting bracket and the transmission control switch mounting bracket are welded together as a complete unit. It will be necessary to follow procedure for power unit and transmission switch removal and disconnect the shift rod and cross-over rod at power shift and manual shift bell crank, disconnect clutch rod at transmission control switch. After removal of the power unit and transmission switch, remove two bolts at lower bracket support, one bolt at oil pan bolt at front and two nuts and lockwashers at side of cylinder block. This will allow removal of the complete bracket with power shift shaft and shift levers attached for disassembly on bench.

## POWER UNIT TRANSFER DIAPHRAGM ENGAGING ROD AND/OR ROD END AND SLEEVE

### REMOVAL:

1. Hold diaphragm rod end with a suitable wrench and loosen the lock nut.
2. Hold diaphragm engaging rod with pliers and back out sleeve nut sufficiently to remove shift rod from transfer key ball.

### INSTALLATION:

To install, reverse procedure of removal and adjust diaphragm engaging rod to obtain 1-3/16" between front face of rod end and rear face of diaphragm housing with sleeve nut adjusted so that rod swivels freely on transfer key ball without any appreciable end play.

## POWER UNIT SHIFT STRAP

### REMOVAL:

1. Remove bolt and shakeproof lockwasher at power cylinder.

**NOTE:** When replacing shift strap, use a heavy internal tooth or heavy standard split lockwasher.

2. Remove cotter pin, plain washer and disconnect neutral and limit switch rod.
3. Remove inner cotter pin, flat washer, anti-rattle washer and remove shift strap.

**INSTALLATION:** Reverse procedure of removal.

## TRANSFER KEY

### REMOVAL:

Use procedure of "Power Unit Transfer Diaphragm Engaging Rod" and remove cotter pin and clevis pin from transfer key.

**NOTE:** Push shift shaft to rear to allow clearance for cotter pin removal.

**INSTALLATION:** Reverse procedure of removal and check adjustment.

**NOTE:** To lubricate transfer key, grasp diaphragm engaging rod and pull towards front of car. This action will allow clearance at transfer key alemitte for lubrication gun.

## DRIVE-MASTER SHIFT SHAFT AND/OR SHIFT SHAFT LEVERS

### REMOVAL:

1. Remove shift shaft nut located at rear of Drive-Master support bracket. (It will be necessary to disconnect transfer switch rod at transmission switch to allow more wrench clearance.
2. Remove cotter pin and clevis pin and disconnect power shift rod.
3. Slide shift shaft out toward fender (use care as detent balls and springs may fall out of their retainers).

**INSTALLATION:** Reverse procedure of removal and make sure the detent ball springs are properly positioned as follows. Part # 163442-19 pound spring when compressed to 11/16" is assembled in Drive-Master mount-

