

## INTERPRETATION, APPRAISAL, AND APPLICATION

### MERIT ASSESSMENT OF OBSERVATION AIDS

The relative merits of the existing observation approaches (which were identified during the site investigations) and the most suitable, technically feasible conceptual observation approaches were assessed. This assessment was made using evaluation criteria developed on the basis of a wide range of operational procedures, equipment and facility configurations, and passenger behavior patterns. Observations made during the site visits and information collected using the survey questionnaire were used to develop these criteria. Although the criteria are general and cannot address all of the nuances of individual operations, they represent a consensus of the requirements of observation aids. Because some criteria are more significant than others, operational significance factors were applied to weight the more significant areas.

In performing these assessments, each observation aid approach was first analyzed individually relative to the criterion and assigned a grade that was multiplied by the weighting factor to obtain a factored grade. When this process was completed for all observation aids and evaluation criteria, the relative merits of each were compared. Essentially, this comparison consisted of totaling the factored grades and comparing the sums.

### MERIT ASSESSMENT APPROACH

Merit assessments of candidate observation aids were performed in phases. The precursor to the assessments was the development of a detailed set of criteria. These criteria were based heavily on observations made during the site visits and information provided by transit authority personnel during meetings associated with the visits. As defined, the criteria constitute the following six categories:

- Observation requirements,
- Facility characteristics,
- Environmental factors,
- Vehicle characteristics,
- Operational factors, and
- Life-cycle costs.

While criteria falling into each of these categories are important in determining the overall effectiveness of observation aids, some criteria are more important than others. To address these importance variances, weighting factors were assigned to each criterion. These weighting factors range from 1 to 10 with 10 being assigned to the most important factors. In general, factors related to the ability of the aid to meet the observation requirements were rated the

highest, with the others rated progressively lower. By using this approach, all factors can be addressed in the merit assessments without lower importance factors skewing the results. Table 3 lists all criteria used in the merit assessments and the assigned weighting factors.

### ASSESSMENT CRITERIA

As introduced above, the assessment criteria were grouped into six categories. The following paragraphs define the assessment criteria in each of these categories as well as the weighting factor applied and the general approach used in scoring.

#### Observation Requirements

##### *Platform Approach*

As a train approaches the station, the track and the platform are observed to identify any situation requiring emergency action. The ability of the various approaches to assist the operator in observing the station areas during the approach are evaluated. A score of 10 indicates that the system provides considerable assistance to the operator in viewing the area. If no feedback is given, then a 0 score is applied. Because this criterion is not central to door observation but a significant adjunct, it has been assigned a weighting factor of 7.

##### *Train Alignment Verification*

The operator verifies proper berthing alignment before opening the doors, whether the train is operating under automatic or manual control. A score of 10 is given if the observation aid can provide the crew with positive alignment verification. Lesser degrees of verification are awarded progressively lower scores. Because berthing alignment is significant in selected cases but not central to door observation, this criterion has been assigned a weighting factor of 7.

##### *Boarding Observation*

Two subcriteria are defined for boarding observation. The first of these is normal boarding. This subcriterion represents the capability of an observation aid to provide information about passenger unloading and loading and the extent of information provided to the operator to determine when and if the

TABLE 3 Merit assessment of observation approaches

Evaluation Criteria	Operational Significance Factor	Direct Visual Observat		Mirror-Vehicle Mounted		Mirror-Platform Mounted		CCTV Plt- Mon Plt-Cam		CCTV Veh- Mon Plt-Cam		CCTV Veh- Mon Veh-Cam		Microwave Sensors		Photoeye Sensors		Dual Sensor System	
		Value	Fctrd	Value	Fctrd	Value	Fctrd	Value	Fctrd	Value	Fctrd	Value	Fctrd	Value	Fctrd	Value	Fctrd	Value	Fctrd
<b>Observation Requirements</b>																			
Station Approach	7	9	63	0	0	0	0	0	0	10	70	3	21	0	0	0	0	0	0
Train Align. Verif. Boarding	7	10	70	8	56	8	56	8	56	8	56	8	56	0	0	0	0	0	0
Normal Operation	10	10	100	8	80	9	90	9	90	9	90	9	90	5	50	6	60	9	90
Late Boarding	10	10	100	8	80	9	90	9	90	9	90	9	90	8	80	0	0	9	90
Closed Doors	10	10	100	10	100	10	100	10	100	10	100	9	90	2	20	0	0	2	20
Station Departure	7	9	63	7	49	0	0	0	0	10	70	2	14	0	0	0	0	0	0
	51		496		365		336		336		476		361		150		60		200
<b>Facility Characteristics</b>																			
Platform Curvature	10	5	50	1	10	5	50	9	90	9	90	7	70	10	100	10	100	10	100
Multi Berth Platform	5	10	50	10	50	2	10	2	10	10	50	10	50	10	50	10	50	10	50
Multi Route Plat	1	10	10	10	10	10	10	2	2	2	2	10	10	10	10	10	10	10	10
Multi Direction Plat	1	10	10	10	10	10	10	10	10	10	10	10	10	10	10	10	10	10	10
Station Obstructions	10	2	20	2	20	3	30	5	50	5	50	7	70	10	100	10	100	10	100
Platform Lighting Char. Intensity	5	8	40	7	35	7	35	8	40	8	40	8	40	10	50	10	50	10	50
Consistency Day to Day	5	10	50	10	50	10	50	9	45	9	45	9	45	10	50	10	50	10	50
Along Platform	5	8	40	6	30	7	35	5	25	5	25	5	25	10	50	10	50	10	50
	42		270		215		230		272		312		320		420		420		420
<b>Environmental Factors</b>																			
Temperature/Humidity	3	10	30	10	30	10	30	10	30	10	30	10	30	10	30	10	30	10	30
Glare/Shadows	2	5	10	2	4	3	6	5	10	5	10	5	10	10	20	10	20	10	20
Precipitation	3	10	30	8	24	9	27	9	27	10	30	10	30	8	24	10	30	9	27
	8		70		58		63		67		70		70		74		80		77

TABLE 3 Merit assessment of observation approaches (continued)

Evaluation Criteria	Operational Significance Factor	Direct Visual Observat		Mirror-Vehicle Mounted		Mirror-Platform Mounted		CCTV Plt- Mon Plt-Cam		CCTV Veh- Mon Plt-Cam		CCTV Veh- Mon Veh-Cam		Microwave Sensors		Photoeye Sensors		Dual Sensor System	
		Value	Fctrd	Value	Fctrd	Value	Fctrd	Value	Fctrd	Value	Fctrd	Value	Fctrd	Value	Fctrd	Value	Fctrd	Value	Fctrd
<b>Vehicle Characteristics</b>																			
Car Type/Length	4	10	40	10	40	10	40	10	40	10	40	10	40	10	40	10	40	10	40
Consist Length	5	10	50	10	50	10	50	10	50	10	50	10	50	10	50	10	50	10	50
Freq of Consist Changes	4	10	40	10	40	10	40	10	40	10	40	10	40	4	16	4	16	4	16
Door Control Loc.	2	10	20	10	20	2	4	2	4	10	20	10	20	10	20	10	20	10	20
	15	150		150		134		134		150		150		126		126		126	
<b>Operational Factors</b>																			
Crew Size	4	10	40	10	40	10	40	10	40	10	40	10	40	10	40	10	40	10	40
Pass. Procedural Chgs.	2	10	20	10	20	10	20	10	20	10	20	10	20	8	16	8	16	8	16
Operational Complexity	4	10	40	10	40	10	40	9	36	9	36	9	36	9	36	9	36	9	36
	10	100		100		100		96		96		96		92		92		92	
<b>Life Cycle Costs</b>																			
System Complexity	5	10	50	10	50	10	50	9	45	7	35	6	30	4	20	4	20	4	20
Install. Complexity	5	10	50	9	45	9	45	7	35	6	30	7	35	7	35	7	35	7	35
Training	3	10	30	10	30	10	30	8	24	9	27	9	27	9	27	9	27	9	27
System Reliability	7	10	70	10	70	10	70	9	63	7	49	7	49	7	49	8	56	7	49
Maintainability	5	10	50	10	50	10	50	9	45	8	40	6	30	7	35	7	35	6	30
Vandalism Resistance	4	10	40	9	36	2	8	4	16	7	28	9	36	8	32	8	32	8	32
	29	290		281		253		228		209		207		198		205		193	
		=====		=====		=====		=====		=====		=====		=====		=====		=====	
<b>Total Scores</b>		<b>1376</b>		<b>1169</b>		<b>1116</b>		<b>1133</b>		<b>1313</b>		<b>1204</b>		<b>1060</b>		<b>983</b>		<b>1108</b>	

doors are clear. A higher score is provided to those observation approaches that provide complete information to the train crew. Because this subcriterion is central to the task of door observation, it has been assigned a weighting factor of 10. The second subcriterion, late boarding, addresses the ability of the aid to detect and provide information on passengers attempting to enter the train as the doors are closing. Again, a higher score is provided to those systems that provide complete information as well as advance warning of the situation. Because this subcriterion is central to the definition of the door observation process, it has been assigned a weighting factor of 10.

#### *Closed Doors*

This assessment criterion is a measure of the ability of the observation aid to provide information to the train crew if a person or object is caught between the doors after closing. A significant part of this evaluation is a measure of the size of the objects that can be detected. If the system can provide positive feedback, it receives a score of 7. If the system can detect small objects, it receives an additional score of 3. Detection of persons and objects between closed rail car doors is required to prevent dragging incidents; therefore, this criterion is of significant importance and is assigned a weighting factor of 10.

#### *Station Departure*

Similar to train approach, the observation of the platform as the train departs the station is required and performed to identify situations requiring emergency action. Although diligent observation during door closing will significantly reduce the likelihood of emergencies, they do still occur—making this criterion important. Observation aid approaches that enable the operator to observe the platform for at least three car lengths during departure are awarded a score of 10, with declining scores awarded for approaches providing coverage for shorter distances. An approach providing no coverage during departure receives a score of 0. Because this criterion is significant in enhancing passenger safety but not central to the door observation, it has been assigned a weighting factor of 7.

### **Facility Characteristics**

#### *Platform Curvature*

As indicated previously, platform curvature is one of the most significant station characteristics affecting door observation. This criterion is a measure of the ability of the observation aid to accommodate platforms with convex and concave edge curvatures as well as compound curvatures, such as S-curves. A score of 10 is assigned if the system helps to overcome the problems caused by curvatures and can accommodate variations from one station to the next. If the system requires adjustment for individual stations but still enables the operator to observe all conditions, a score of 6 is

applied. For those approaches with limited curvature accommodation, a score of 3 is awarded. Those approaches that cannot accommodate curvatures are awarded a score of 0. Because this criterion addresses a significant facility characteristic influencing observation, it is assigned a weighting factor of 10.

#### *Multiple Berth*

This criterion addresses the ability of the observation aid to accommodate flexibility in train lengths and multiple berthing points within a station. If the system is not affected by variances, a score of 10 is awarded. For ability to adjust to minor changes, the score is reduced to 7. A score of 0 is awarded to systems with no flexibility. This criterion is a function of the operations at a specific transit property. Systems with no variances in stopping positions are affected by this criterion; those with multiple stopping points are greatly affected. Because the merit assessment included in this report is designed to represent a consensus, this criterion is assigned a weighting factor of 5.

#### *Multiple Routes*

Several transit systems have multiple routes that share the same station platform. This criterion addresses the ability of the observation aid to accommodate this operational scenario. For the merit assessment provided in the report, it has been assumed that the rail vehicles used for all routes are the same or have equivalent characteristics from the standpoint of performing door observation. Where the observation aids are not influenced by different routes, a score of 10 is applied. Because few applications of this operational methodology were observed during the transit property site visits, this criterion is assigned a weighting factor of 1.

For systems using different vehicles for multiple routes serving the same platform, the scores and weighting will need to be adjusted. These adjustments will consist of decreasing the score on the basis of the extent of the impact and adjusting the weighting factor on the basis of the perceived importance.

#### *Multiple Direction*

During the transit property site visits, only a few cases were observed where trains were operated in multiple directions servicing a single platform. One such example is Baltimore's MTA Light Rail line that has a single-track right of way at the northern and southern ends with a single platform at each station. Observation aids not influenced by this arrangement are awarded a score of 10 with others receiving progressively lower scores on the basis of the degree of the impact. Generally, carborne systems will receive a score of 10 because the direction of the train at a particular station has no effect on the function of the observation aid. Because of the limited applicability of this criterion, it has been assigned a weighting factor of 1.

### *Station Obstructions*

Along with platform curvature, station obstructions are the most significant facility characteristics affecting door observation. Those observation aids that are affected to little or no degree by platform obstructions are awarded a score of 10. These systems can handle all but the most severe and unusual obstructions. Approaches with limited flexibility or requiring special adaptations are awarded values established on the relative flexibility of the system. Observation aids that do not provide visibility of significant areas of obstructed platforms are awarded scores of 0. Because this criterion addresses a significant facility characteristic influencing observation, it is assigned a weighting factor of 10.

### *Platform Lighting Characteristics*

Platform lighting characteristics comprise three subcriteria that must be addressed separately. These subcriteria are lighting intensity, lighting consistency, and lighting source types. In addition, when evaluating lighting consistency, daily consistency for surface stations must be addressed because ambient lighting varies with the time of year. Also, the consistency across the length of the platform must be addressed because it varies with station structures (e.g., canopies) for surface stations and with the number and location of lighting fixtures for subway locations.

Lighting intensity addresses the influence of ambient lighting levels on the performance of an observation aid. For vision-based aids (e.g., mirrors and CCTV), this subcriterion is most significant. Sensor-based systems are not affected by this subcriterion because they do not rely on visible light for their operation. It is also important to note that in assessing an observation aid relative to this subcriterion, both high and low levels of light must be considered. For example, extremely high or low levels of light will cause video images to lose contrast, making them unusable. Systems that can function between low levels and bright illumination are awarded a score of 10. If an observation aid cannot accommodate wide differences in intensity but is still functional, it is awarded a score of 5. As indicated above, this subcriterion does not affect all observation aid approaches. Therefore, it has been assigned a nominal weighting factor of 5 to ensure that it will not skew the results toward approaches not based on visible light.

As the researchers observed at SEPTA's Blue line in Philadelphia and PATH's Journal Square station, lighting levels can vary widely across a station platform. Therefore, it is important to assess how well an observation aid operates under different lighting conditions. In addressing this aspect of operations, it is important to consider the daily variations resulting from changes in the position of the sun during the year as well as the consistency of lighting across station platforms (as affected by station structures such as canopies and the distribution of artificial lighting fixtures). Where the observation approach can accommodate changes occurring from 1 day to the next, a score of 10 is awarded. A score of 10 is also awarded if the system can adjust to changes in

illumination levels along the platform. Limitations in the ability of an application to fully handle either case result in lower scores accordingly. As indicated above, this subcriterion does not affect all observation aid approaches. Therefore, it has been assigned a nominal weighting factor of 5 to ensure that it will not skew the results toward approaches not based on visible light.

## **Environmental Factors**

### *Temperature and Humidity*

This criterion addresses the extent to that observation approaches are affected by temperature and humidity extremes. In general, those approaches relying on active electronics will be affected much more than passive approaches, such as mirrors. Systems that will experience no effects from temperature and humidity extremes are awarded scores of 10 with others receiving correspondingly lower scores. Because it is possible to protect electronics from temperature and humidity so that they are roughly equivalent to passive approaches, this criterion has been assigned a weighting factor of 3.

### *Natural Light Levels*

Natural light levels range from bright sun to heavily overcast skies. Those observation approaches not affected by natural light levels are awarded a score of 10 while those affected are awarded a score corresponding to the degree they are affected. This criterion does not affect all observation aid approaches. For this reason, it has been assigned a nominal weighting factor of 5 to ensure that it will not skew the results toward approaches not based on visible light.

### *Glare and Shadows*

This criterion is a measure of the ability of the observation approach to manage glare or shadow conditions while still providing usable information. In general, vision-based approaches (e.g., CCTV and mirrors) are most susceptible to degradation from these conditions; however, good installation design will limit the effects and degree of functional degradation. Those approaches experiencing no degradation are awarded a score of 10 while those affected are awarded progressively lower scores corresponding to the degree and extent of degradation. This criterion does not affect all observation aid approaches. For this reason, it has been assigned a nominal weighting factor of 3 to ensure that it will not skew the results toward approaches not based on visible light.

### *Precipitation*

This criterion accounts for the effects of rain, snow, sleet, and fog in the atmosphere on the viability of an observation approach. Those approaches affected by precipitation are awarded a score adjusted down from a maximum of 10, ac-

ording to the degree and nature of the influence and the amount of precipitation at which degradation begins. Because this criterion applies mostly to surface stations and because most station facilities provide protection from precipitation (through canopies and so forth), this criterion has been assigned a weighting factor of 3.

## **Vehicle Characteristics**

### *Car Type and Length*

Larger, older transit systems often run different types and lengths of cars on a single line. The ability of the approaches to adapt to these changes in car type and length are reflected in this criterion. An observation approach unaffected by vehicle length is awarded a score of 10. Those approaches affected by varying vehicle lengths are awarded a score reflecting the degree of effect. Because the approaches assessed include some tailored for a specific vehicle configuration (type and length) as well as carborne observation aids, this criterion has been assigned a weighting factor of 4.

### *Consist Length*

Nearly all rapid transit systems operate with various lengths of consist throughout the day. If the length of the train has no effect on the observation approach, it is awarded a score of 10. If changes in the consist length require operations to be conducted differently or if train positioning does not allow optimal berthing, the score is revised down accordingly. Because the approaches assessed include some tailored for a specific vehicle configuration as well as carborne observation aids that use equipment on each vehicle in the consist, this criterion has been assigned a weighting factor of 5.

### *Frequency of Consist Changes*

Several transit operating systems adjust the number of cars in the consist throughout the operating day to satisfy peak and off-peak requirements. Carborne systems that are trainlined may require additional connections and disconnections during makeup changes as well as configuration changes because of changes in the active cab. Although it is possible to make these changes automatically and transparently to the train crews, the changes will result in increased observation aid hardware costs. For example, observation aids featuring vehicle-mounted monitors used in systems that change consists frequently and in unpredictable patterns will require monitors mounted in all cabs. This will result in increased overall system costs. For those observation approaches and aids that do not require reconfiguration or additional hardware to account for consist changes, a score of 10 is awarded. Those observation aids that must account and reconfigure for consist changes are assigned lower scores corresponding to the extent of the hardware required. Because most transit properties operate with a small and fixed number of consist

sizes and configurations and the effects of the variations can be accounted for in the observation aid designs, this criterion has been assigned a weighting factor of 4.

### *Door Control Location*

Observation approaches that are affected by changes in door control locations, particularly where two-person crews are used, will be weighed according to the relative impact on changes in operator's functions. In general, approaches relying on platform-mounted (fixed location) hardware are awarded lower scores while those with vehicle-mounted equipment receive higher scores. Because this criterion can be accounted for in the designs of observation aid installations, it has been assigned a weighting factor of 2.

## **Operational Factors**

### *Crew Size*

Any changes or adjustments in crew size and corresponding workload that would affect the effectiveness or use of the approaches is addressed under this criterion. If the system provides equivalent functionality for any crew size (but at least one for staffed operations), then a score of 10 is awarded. Because all transit systems visited under the project and those that responded to the survey indicated consistent crew sizes, this criterion has been assigned a weighting factor of 4.

### *Passenger Procedural Changes*

On several of the transit systems visited, operating procedures are changed during off-peak and late night hours to enhance the safety of passengers. Included among these procedures is having the trains stop closer to the center of the platform and providing a demarcated area for passengers to wait at these times. This criterion addresses the ability of an observation approach to continue to provide suitable information under these circumstances without reconfiguration or repositioning of equipment. Those approaches providing consistent results under these conditions are assigned a score of 10, while those providing differing results are assigned scores corresponding to the degree of the differences. Because the operating procedures and conditions addressed by this criterion are used at only a few transit properties, this criterion is assigned a weighting factor of 2.

### *Operational Workload*

In all cases, use of an observation methodology requires action on the part of the train crew. This criterion addresses the extent and nature of these actions and how they affect the train crew's workload. Those approaches requiring minimal operator actions are awarded scores of 10 while approaches requiring more action on the crew's part are awarded corres-

pondingly lower scores. Using direct visual observation as the comparison metric, the researchers anticipate that observation aids generally will reduce train crew workload over present levels. For this reason, this criterion has been assigned a weighting factor of 4.

## Life-Cycle Costs

### *Hardware Complexity*

Excluding direct visual observation, each of the observation approaches assessed requires some form of hardware to implement. This criterion assesses the relative complexity and cost of this hardware. Because it requires no hardware to implement, direct visual observation is awarded a score of 10. Mirrors have low cost and, as such, are assigned a score of 9. Other approaches require more hardware and have been awarded correspondingly lower scores. Because the system complexity contributes the most to the life-cycle cost, this criterion has been assigned a weighting factor of 9.

### *Installation Complexity*

In addition to the hardware costs described above, installation is a significant part of the initial procurement cost for an observation aid. This criterion addresses this cost. For direct visual observation, there are no installation costs and the approach is awarded a score of 10. Equipment that must be platform-mounted costs more because power and signal cabling are required and, therefore, is awarded lower scores. Carborne equipment can be designed into the vehicles or retrofit into existing equipment and, as a result, is awarded a score of 7. While installation costs are lower than hardware procurement costs, they remain significant; therefore, this criterion is awarded a weighting value of 5.

### *Training*

The level of training required to use an observation approach is generally tied to the system complexity. This criterion addresses the level of user training required to employ an observation approach. Sensor-based observation approaches require minimal training because they automate observation functions and require very little operator action; therefore, these systems are awarded higher scores than direct visual observation. According to the degree to which it contributes to overall lifecycle costs, training is assigned a weighting factor of 3.

### *System Reliability*

System reliability determines the extent to which an observation aid will need to be repaired or have individual components replaced over its life cycle. Although systems based on active electronic hardware are inherently more complex than systems based on passive devices, the electronics-based approaches employ nondevelopmental

commercial technology that exhibits high reliability. For this reason, there is no wide range of reliability scores across the various observation approaches. Because they are passive (i.e., nonelectronic) approaches, direct visual observation and mirrors were awarded the highest scores. Electronics-based approaches were awarded lower scores because of their historical or projected reliability. Because reliability is critical to the availability of an observation aid to perform its intended function and to life-cycle maintenance costs, this criterion has been awarded a weighting factor of 7.

### *Maintainability*

The maintainability of an observation aid is directly related to its complexity. As indicated above, all of the electronics-based observation aids are based on nondevelopmental commercial technology. In most cases, the system designs are modular and the low cost of the modules makes them throwaway rather than repair items. For this reason, there will be no significant spread in the scores awarded to the various system approaches. In addition to the general maintainability of the system, this criterion also addresses the need for preventive maintenance and periodic recalibration or alignment of the equipment. Because of its contribution to overall life-cycle costs, maintainability has been assigned a weighting factor of 5.

### *Vandalism*

Transit facilities are susceptible to vandalism. This is particularly true of systems that extend into loosely populated outlying areas and systems with 24-hour operations. This criterion addresses the susceptibility of an observation approach to be degraded or rendered inoperable by vandalism. Those systems having vehicle-mounted equipment are less susceptible to vandalism than those with fixed (platform-mounted) assets and are awarded scores accordingly. Because of the varying effects of vandalism on the transit systems visited, this criterion has been assigned a weighting factor of 4.

## ASSESSMENT RESULTS

Grades were assigned to evaluate the systems against a common, generalized operational scenario. Localized peculiarities of individual transit systems were not considered. In making the evaluations, it was necessary to define metrics for the evaluation. Multiple types of transit operating systems were observed during the site investigations. These included light rail and heavy rail systems and both staffed and unstaffed operations. For the evaluations, a heavy rail design operating with one-person crew operating under manual control was applied because it presents the most stringent conditions. Conditions presented by light rail, unstaffed, or automatic operations represent a subset of the heavy rail application requirements and the same relative rankings will apply.

Each evaluation criterion was assigned a value for relative

significance in an overall analysis of transit system operations. Issues affecting safety requirements and effectiveness received the highest weightings. Approaches or systems that fulfill observation requirements received weighting values of 10. Similarly, issues related to the effectiveness and reliability of the system received high weighting values. Criteria reflecting issues related to modes of operation and flexibility to multiple scenarios, while still very important, were evaluated as having less relative significance to overall operations.

Table 3 illustrates the assigned and factored values for each of the existing and conceptual observation approaches. Although the total score is useful, the evaluation of subtotals by category indicates the relative merit and general applicability of the defined approaches. As shown in the table, direct visual observation without the use of observation aids is the best approach. Considering all aspects of the assessment, this is not unexpected. The approach is simple, has no initial life-cycle costs (compared to other approaches), adapts to many system changes, and is effective.

For cases where an observation aid is applied, a CCTV-based observation aid with platform-mounted video cameras and vehicle-mounted monitors was rated the best—primarily because of the flexibility it provides in addressing various operational, vehicle, and facility characteristics. The following paragraphs discuss the results by category.

### **Observation Requirements**

This category is the most important for evaluating the overall merits of an observation approach. How well an observation approach provides clear, concise information on passenger status is of utmost concern. Approaches where visual observation is provided to the operator for the five observation tasks rated substantially higher because of their ability to cover multiple aspects of observation. Carborne sensor systems generally cover a narrower range of aspects of observation but at a more consistent and higher level of application.

### **Station and Environmental Characteristics**

Carborne detection systems are generally unaffected by changes in the specific configuration or environmental aspects of transit facilities. Visual-based approaches are affected in

various ways and to varying degrees by station structures and environmental factors. The degree of influence is subjective, because the extremes in ranges of the criteria can be compensated for by system modifications to basic operational characteristics.

### **Train and Operational Characteristics**

Visual approaches are only slightly more adaptable to variations in vehicle characteristics and operations than sensory devices. A wider, less dedicated area is covered by vision systems, because the approaches are more adaptable to changes in the specified criteria.

### **Physical Characteristics**

Vision systems are generally less complex in design and operation and have fewer support requirements than sensory detection methods. This is especially true for direct visual and mirror-based approaches, which have little or no cost for installation and maintenance. Trainlined carborne approaches are more complex and have higher installation and maintenance requirements.

## **MERIT ASSESSMENT SUMMARY**

As part of the merit assessments, the demonstration phase of the program evaluated the highest-rated approaches for the two primary types of systems evaluated—visual and sensory. Direct visual observation was used as a baseline because it is the most commonly employed approach for the observation of car side doors. To evaluate the visual approaches, CCTV (using platform-mounted cameras with both platform-mounted and vehicle-mounted monitors) was demonstrated. Several sensory detection systems were evaluated through laboratory testing. On the basis of this testing, the researchers selected a microwave motion-detection system for demonstration. On the basis of the demonstration, the researchers recommend that, if a sensor-based system is pursued, it should employ multiple sensors in order to lessen the shortcomings of individual sensor-based systems and to ensure that the effectiveness of the system approaches that of CCTV-based systems.

---



## CONCLUSIONS

### OBSERVATION AID USAGE GUIDELINES

Having studied current and conceptual observation aids, the researchers have developed a set of usage guidelines. Although the technology employed in the design of these systems is important, application design is equally important, because a poorly applied observation aid will be ineffective—regardless of the technology it incorporates.

The following sections of this chapter provide usage guidelines for CCTV-, mirror-, and sensor-based observation aids. In reviewing these guidelines and considering their use, readers should note that the guidelines are not intended to provide absolute guidance. Each use of an observation aid has nuances that must be addressed case by case in a way that reflects the specific characteristics of a transit property's vehicles, facilities, operational procedures, and passenger behavior.

### CCTV OBSERVATION AID USAGE GUIDELINES

By obtaining exposure to various CCTV-based observation aids through site visits and review of the state of the art in CCTV technology, the researchers were able to develop guidelines for system design and implementation. These guidelines address the requirements of the transit community in a broad sense and provide a starting point and structure for developing CCTV observation aid system specifications. The guidelines address the system architecture, general considerations (such as defining the extent of the observation aid), and system components. These guidelines are designed to provide the user with a logical path through system specification development.

#### CCTV System Architecture Guidelines

The first step in developing a CCTV-based door observation system is to define the general system architecture. This includes determining the image type to be used (i.e., color or monochrome), camera installation and location design, monitor location, and monitor display format. The following paragraphs address each of these aspects of CCTV system architecture.

##### *Image Type*

CCTV systems can be designed to support monochrome (black and white) or color images. The technology associated with each is fully mature, and the components required to implement each are readily available, commercial-off-the-shelf equipment. Color is the best approach to CCTV-based

door aids because of the high degree of contrast between image elements (e.g., rail car, platform structures, and people) provided by color. The researchers found that image elements tended to blend together on monochrome monitors—the mass transit visual environment consists of several shades of gray or colors that generally appear gray because of reduced lighting levels. This includes the gray concrete of platforms and the gray or silver car sides. When monochrome platform images were viewed during site visits, extremely bright colors (such as the yellow of platform warning edges) were virtually indistinguishable from the gray concrete of the platform. The result is lost detail and weak image definition that degrade the overall effectiveness of the observation aid. This is not to imply that monochrome systems cannot be used but to indicate that the merits of color systems outweigh those of monochrome systems.

During the CCTV demonstration at PATH's Journal Square station, a color system was used. The monitor images produced by the system showed the yellow platform edge stripe and varying colors of passengers' clothing. These contrasted strongly with the silver or gray of PATH's rail cars and the gray concrete platform.

A significant factor to consider in selecting a color- or monochrome-based observation aid is the level of ambient lighting in the station facilities. There are contrasting schools of thought on station lighting levels. Some systems, such as Toronto's TTC, feature very brightly lit platforms while others, such as Washington's WMATA, use dim lighting. Currently available color video cameras can operate acceptably with a light level of 0.5 lux or greater. On the basis of light level readings taken in PATH's Journal Square station, as well as other stations at the transit properties visited, color cameras operating at 0.5 lux will be suitable for virtually all locations.

The decision to employ color or monochrome need not be absolute. It is possible to use color in some locations and monochrome in others; however, one type is recommended for the sake of consistency. Cameras and monitors need to be selected for color or monochrome operation. Other system components, such as image processing equipment and platform and rail car transmission links, will operate with either color or monochrome images.

All of the CCTV systems seen during the site visits employed monochrome images. Personnel at the properties indicated that although color was desirable, the costs were prohibitive. SEPTA in Philadelphia will be the first property in North America to implement color image observation aids—the system is to be installed concurrent with the purchase of new rail cars for the Market-Frankford line. At one time, there was a significant difference in the cost of color and monochrome CCTV system components; however, this difference has nar-

rowed as technology has advanced. Generally color video cameras and monitors cost approximately 40 percent more than their monochrome equivalents.

### *Camera Installation and Location Design*

In developing a CCTV-based observation aid, it is important to select the camera locations carefully. These selections will determine the view of the vehicle doors provided to the train crew and, as such, are critical to the overall effectiveness of the system. The general rule is to install the cameras so that they provide the most direct view of the platform edge and rail car side as is possible. Where feasible, objects that would clutter the image, such as columns and signs, should be avoided or placed at the extreme edges of the image frame. In this way, the observer can focus on the subject and is not distracted by clutter.

There are two approaches to positioning cameras. One approach is to obtain images of the car sides that allow the door locations to be specifically identified. Although this approach generally requires more cameras, it allows them to be drawn back from the sides of the rail car. This will increase the observation zone out from the side of the rail car and will warn the train crew of such situations as a passenger running to enter closing doors. This approach is generally not applicable to platforms with many obstructions, such as columns. In these cases, it is better to sight along the rail car side as is described later in this section.

Figure 28 shows the view provided to the train crew using this approach. This approach will allow the train operator to identify which particular set of doors is obstructed. This approach will require approximately one camera for each pair of cars in the train consist, assuming a rail car length between 60 and 75 ft.

Figure 29 illustrates the geometric and trigonometric relationships involved in positioning a camera using this approach. By examining the mathematical relationships shown in this figure, it can be seen that, from the known information (camera field-of-vision and car pair length), it is not possible to calculate the camera position precisely. An additional piece of information, such as the distance from Point A to C or from Point A to B, would be required to apply the law of cosines. Because of this situation, experimentation is required to position the camera. Appendix D contains a Microsoft Q-Basic computer program that can aid in camera positioning. This program will calculate setback values (i.e., HS and VS) and incident angles, as well as the required lens field-of-vision on the basis of vehicle characteristics.

A good starting point for these experiments is to aim the camera at the center of the first car (i.e., have the center of the camera field aimed at the center of the first car). Although this will cause the image of the first car to be dominant, sufficient portions of the second car will be visible. In addition, the camera angle of incidence will be no greater than  $30^\circ$ . As the camera angle of incidence approaches  $90^\circ$  (camera perpendicular to the car side), likelihood of glare increases. Figure 30 shows glare off the bare metal side of a rail car. This photo was taken from a point where the angle of

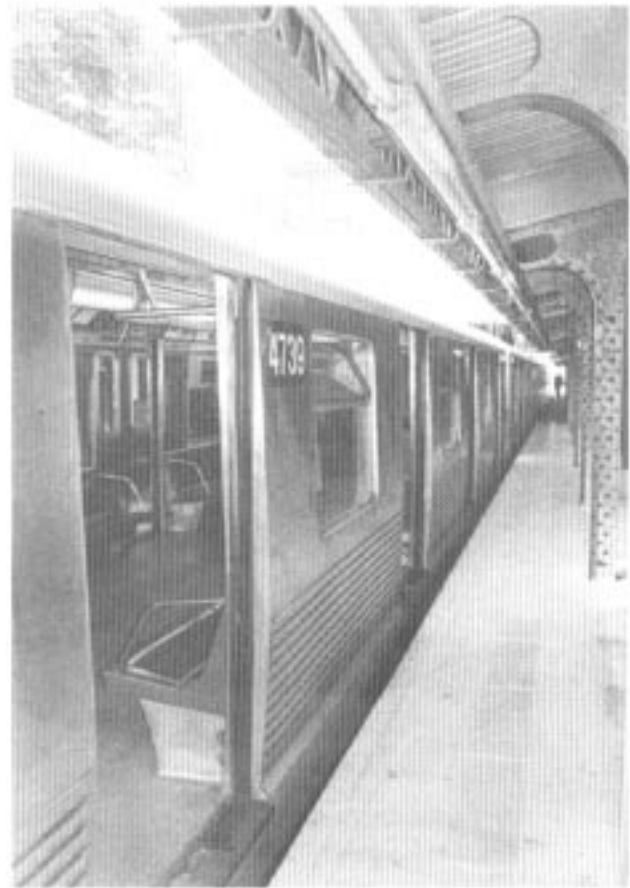

Figure 28. Rail car side imaging approach.

incidence relative to the car side was approximately  $60^\circ$ .

For this scenario, the nominal camera angle of incidence will be approximately  $15^\circ$ . When performing these experiments, move the camera to reduce the angle of incidence until sufficient portions of the first and second car can be seen in the image.

If a split-screen display is to be used, the required part of the image must be condensed to half of the camera image because split-screen devices use half of the image from each camera to produce the split-screen image.

A screen splitter has left and right inputs called master and slave, respectively. The left side of the image provided by the camera connected to the left input to the screen splitter fills the left side of the image output by the screen splitter. Similarly, the right side of the image of the camera connected to the right input fills the right side of the screen splitter output. The objects of interest must be positioned in the appropriate side of the image if a screen splitter is used. Often screen splitters are used with camera lenses with wider fields of vision (i.e., shorter focal lengths) to compensate for the effects of the use of a screen splitter.

A second approach to camera positioning is to sight along the plane of the car side. Figure 31 illustrates this approach.

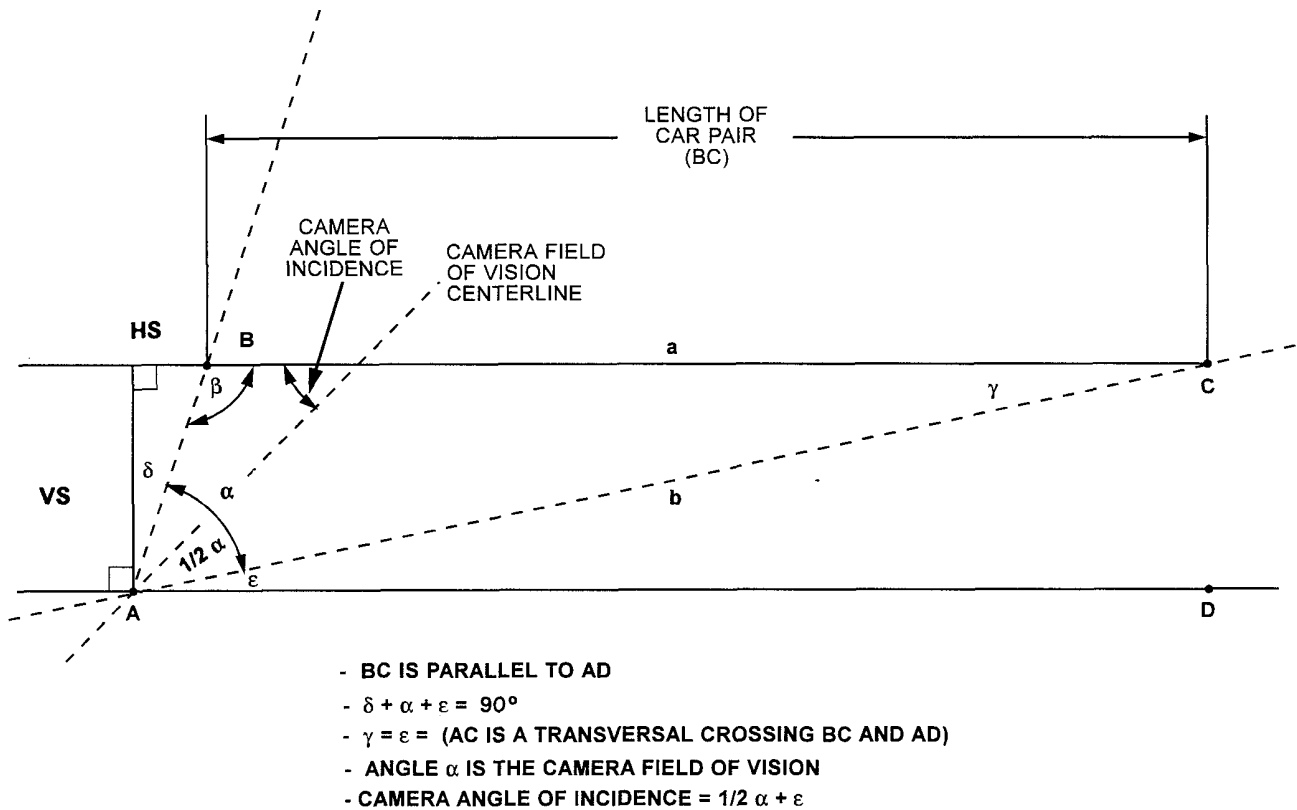

Figure 29. Camera installation guidelines (side imaging).

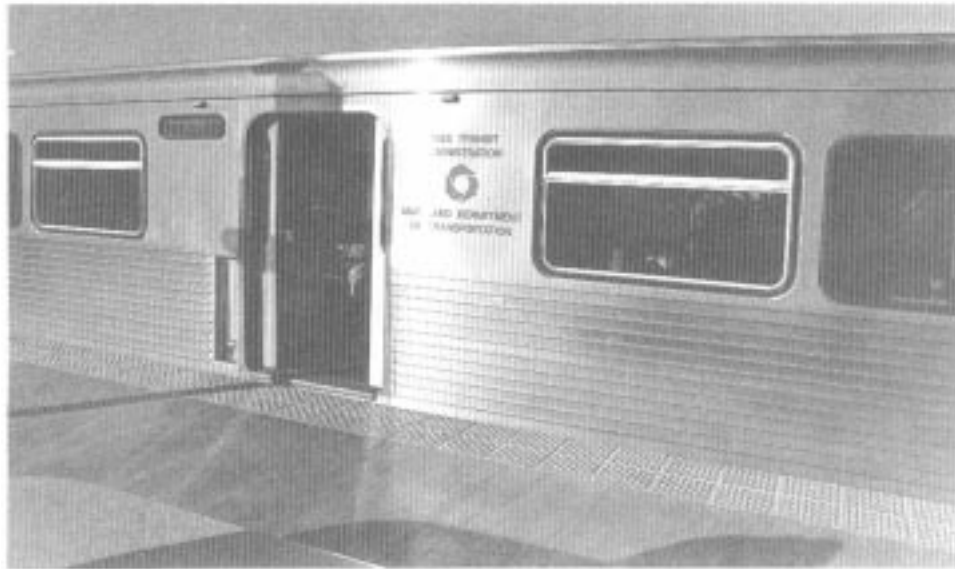

Figure 30. Rail car side glare.

In this case, the train operator can see if a door is obstructed but cannot precisely determine which set of doors is affected. The camera field-of-vision is parallel to the car side or the angle of incidence of the camera relative to the car side is very small as

shown in Figure 32. The smaller the angle the better, because, as the angle increases, objects close to the camera will tend to dominate the image; therefore, it may be better if the camera field-of-vision diverges from the rail car side by a



Figure 31. Rail car plane imaging approach.

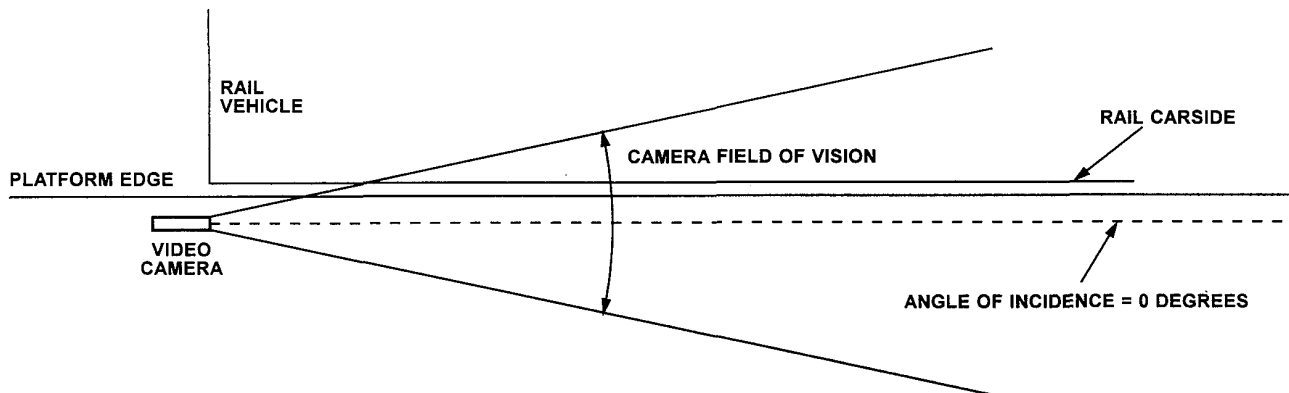

Figure 32. Camera installation guidelines.

few degrees. If this approach is used, caution should be exercised to ensure that objects away from the rail car (e.g., platform structures) do not begin to block the field-of-vision. For this approach to camera placement, a single camera should be used to show no more than 300 ft of platform length.

As shown in Figure 31, as the lines of the platform edge and car sides approach the horizon, considerable detail is lost. When sighting along the car side and using a screen splitter, consideration must be given to the location of objects within the camera field-of-vision as described above.

Another consideration in choosing camera positions is the imaging pattern. Figure 33 illustrates two potential patterns—the sequential pattern and the crossing pattern. In the

sequential pattern, the sides of the rail car are presented to the train operator in a front to back or other logical sequence. The images provided by these cameras can be displayed to the train operator to maintain this logical sequence; this will aid the operator in isolating the specific car where the door is obstructed. This sequential pattern can be beneficial if door areas are displayed directly as described above. In addition, the greater flexibility in camera positioning allows platforms with complex curves (e.g., S curves) to be shown completely.

In the crossing pattern, the fields-of-vision of the camera intersect and overlap slightly. This pattern provides the best results when sighting along the car side plane and is beneficial when showing curves of constant radius.

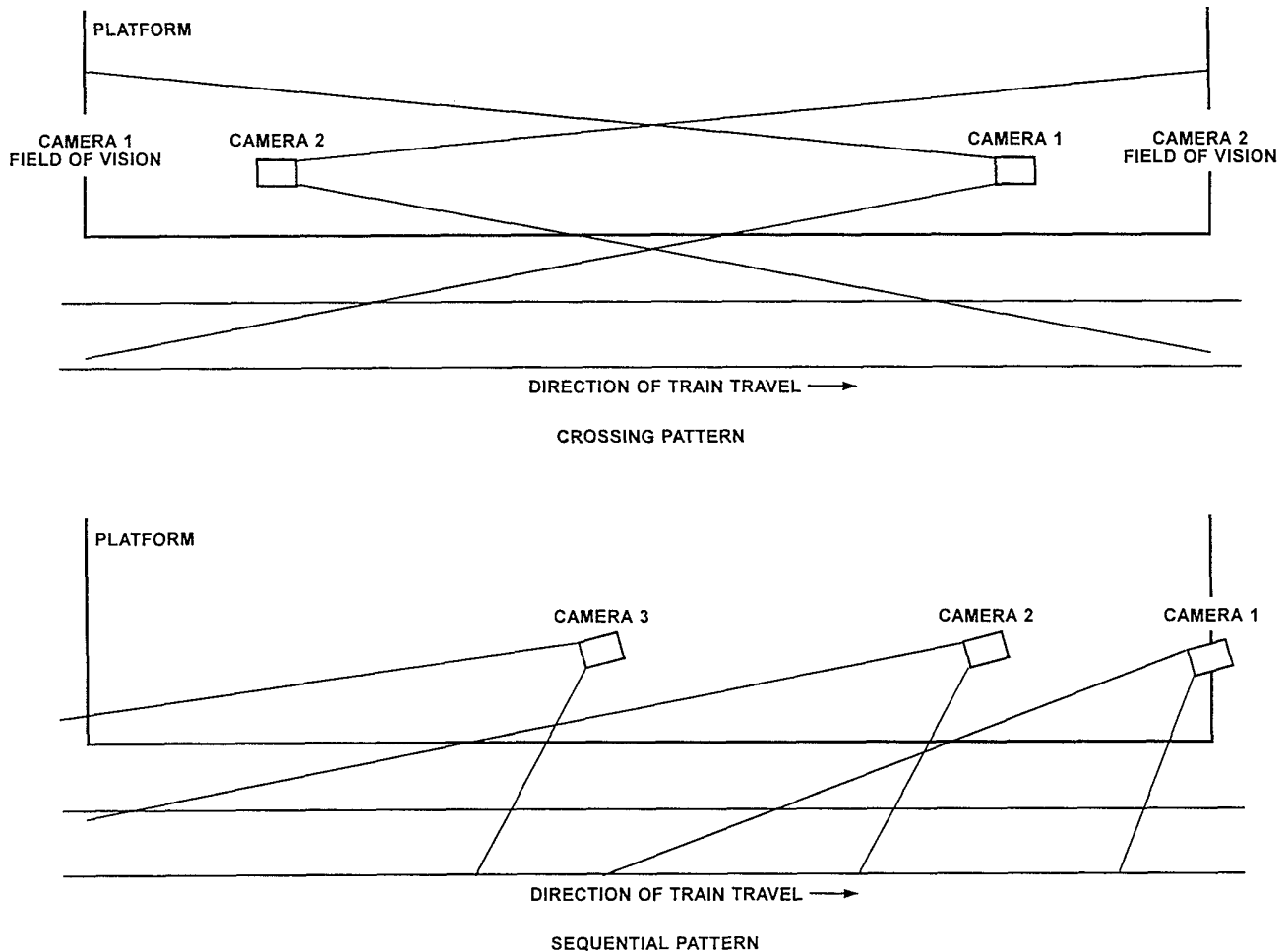

Figure 33. Camera field-of-vision patterns.

If the crossing pattern is used for complex curves, portions of the platform or car side may drop out of view. When employing this approach, the cameras should be positioned so that the fields-of-vision converge at the apex of the platform curvature. During the CCTV demonstration at PATH, this approach was used and met with the approval of the train conductors who viewed the monitor image. Additional details on this approach to camera placement are provided below in the discussion of display formats.

#### Monitor Location

Monitor location has a significant impact on the architecture of CCTV-based observation aids. As described previously, the choices for monitor location include the station platform and the cab of the rail vehicle. Before selecting a location, several factors must be considered. These factors are described in the following paragraphs.

*Extent of the Observation Aid Requirement.* The need for observation aids may be limited to a few stations relative to the total number on the line. The researchers concluded that

direct visual observation is the best approach to door observation; therefore, minimizing the use of CCTV or other observation aids as much as possible is recommended. If a CCTV-based observation aid is required in only a few stations, installation of the monitors in the rail cars will not be cost-effective because of the significant difference in the numbers of rail cars and stations. In this case, the monitors should be platform-mounted. If most of the stations on a line require an observation aid, the consistency of operational rules and train operator actions may warrant universal application and use of an observation aid with vehicle-mounted CCTV monitors.

*Equipment Consists.* Sometimes, trains are assembled into consists that are maintained for extended periods. Because this results in fewer active train cabs, it may be more cost-effective to install monitors in the cabs. Similarly, where lead and trailer units are employed, it may be cost-effective to use cab-mounted monitors because they will only need to be installed in the lead units. Where equipment consists are continually being assembled and broken down, using cab-mounted monitors may be prohibitive because of the cost of equipping numerous cabs.

*Physical Environment.* Most transit systems are susceptible to vandalism. Because platform-mounted monitors must be installed low enough to allow train crew viewing, such monitors are vulnerable to damage. Where vandalism is a significant concern, it is desirable to mount monitors in the train cab. Although a similar threat exists for the cameras, they can often be mounted out of reach under platform canopies or on light stanchions. Ambient lighting conditions are another concern. If monitors are mounted on exposed platforms, the visibility of the monitor displays may be diminished by high levels of ambient light. Although a sun shield, like that used by PATCO, may resolve the problem, it may be desirable to use cabmounted monitors. It is also important to consider that sun position and glare conditions vary. Finally, temperature, humidity, and precipitation must be considered. Although none of the systems visited by the researchers' experience environmental conditions that would render a suitably enclosed monitor inoperable, sporadic weather anomalies in selected locations can create this situation.

### *Display Format*

The best format for displaying information to train crews depends on the number of monitors employed for a given platform. Generally, it is best to present all information to the train crew simultaneously and in real-time to ensure that continuous observations can be made. If a single video camera is used, the only logical alternative is to employ a single, continuous full-screen display.

When two or more cameras are used, several alternatives exist. The most common way to display two camera images is to use a split-screen display. As described above, when using a screen-splitter, the image of one camera occupies the left side of the screen while a second occupies the right. Effectively, these devices will blank half of each horizontal line so that half of the image captured by each camera is being used; therefore, planners must allow for this when selecting camera installation locations for systems designed to use split-screen display formats.

In addition, to ensure that the image output from the screen splitter does not tear or roll, the cameras must be synchronized. This can be accomplished by using the video output of the master camera to provide the synchronization for the slave camera. This is done by routing the video output from the master camera to a distribution amplifier to help maintain signal levels. One output of the distribution amplifier is routed to the screen splitter; the second output is routed to the synchronous input of the slave camera. This input will filter out the video and leave only the synchronous, which will be used to produce output video images. The output of the slave camera can then be routed to the slave input of the screen splitter.

If a split-screen configuration system is to be used, prospective camera vendors should be informed of this to ensure that the slave cameras obtained can accept external synchronization.

When color video cameras are used with a screen splitter, problems may occur because of phasing differences in the color subcarrier signals. If this issue is not addressed, the video image of the slave camera will have incorrect colors.

Most video cameras have internal resistors and potentiometers that can be moved or adjusted to perform phase correction. Selected video cameras have externally accessible potentiometers that can be used for phase correction; such cameras generally cost about 10 percent more than those without external compensation capabilities. This color subcarrier phasing problem arose during the demonstration at PATH; because the camera had internal adjustments, it could not be fixed on the spot.

Figure 34 shows split-screen images used by MTA-NYCT at the Union Turnpike station in the Borough of Queens. The images are presented in back to front order viewing from the left. Also, the images are labeled on the monitor, and labeling is provided for two different classes of rail car (i.e., R32 and R46).

Although users will become acclimated to the camera images after a time, the labels will help new users to quickly understand the views provided to them. This situation was observed during the CCTV demonstration at PATH, where the rear of the train was shown on the left of the monitor and the front was shown on the right. In general, most operators needed to have the view perspective explained to them before they became comfortable using the observation aid. If multiple CCTV installations are used on a route or system, images must be presented consistently to avoid operator confusion. Generally, the researchers agreed that presenting views of the train from front to back, starting from the left of the monitor, is the best approach.

Split-screen combiners are available from numerous manufacturers of CCTV equipment, cost about half that of CCTV cameras, and will support monochrome or color camera inputs.

Where these devices are employed, the camera images should be arranged so that the lines of the picture (e.g., the platform edge) draw the viewer's eye toward the center of the image. This will facilitate viewing and make the information presented in the scene easier for the viewer to interpret. This technique is employed by transit agencies such as PATCO and Vancouver's SkyTrain in its control center. Figure 35 illustrates this technique.

When performing platform observations, the areas of concern are those adjacent to the platform. These areas are marked in the figure. The V formed by the lines of the platform edge and warning stripes draws the viewer's eye from the top to the bottom of the image instinctively. This image scan sequence promotes complete observation of the platform edges without significant conscious effort by the viewer.

An alternative display methodology for two cameras is to use a video switcher that will display a full-screen image of one camera for a fixed time and then will switch to the second camera. The display time for commonly available devices is adjustable from 0.5 to 60 sec. The interval selected should allow the train operator sufficient time to view the image and assess the information presented—generally on the order of 2 to 4 sec depending on the clutter (e.g., physical structures) in the image.

A significant drawback with this approach is that passenger movements and door conditions are dynamic and an event may occur—when an image is not displayed—that could pose a hazard. One such example is a passenger running down a staircase or emerging from behind an obstruction to enter a rail car.

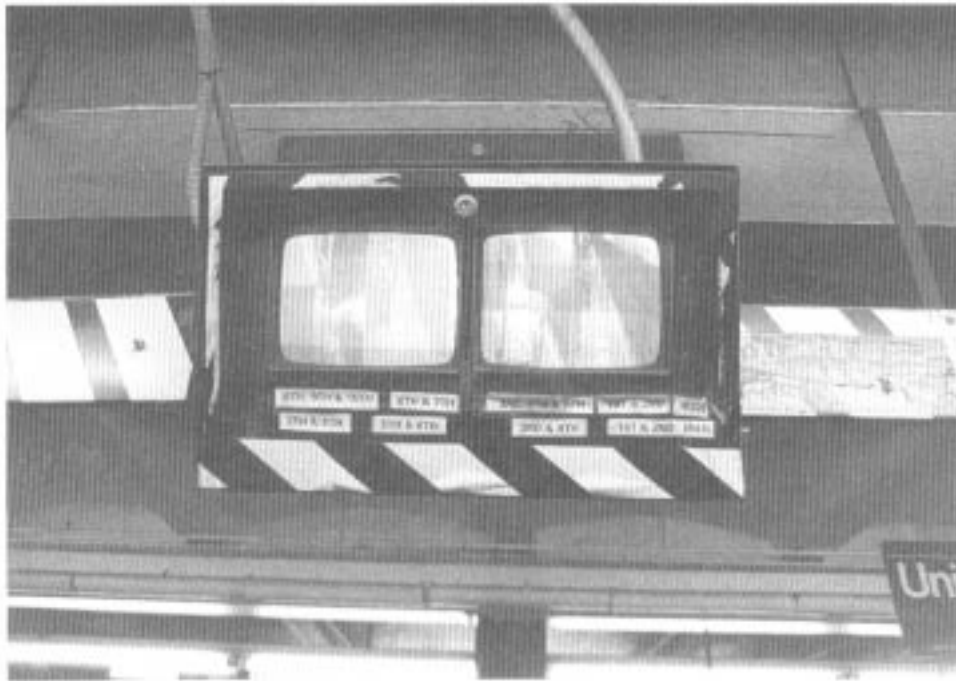

Figure 34. MTA-NYCT split-screen image presentation.

Another drawback is that short dwell times may not allow an image to be displayed often enough for the train operator to assess door status adequately. Where this approach is used, the image sequence should provide views of the train from front to back repeatedly.

When three or more cameras are used, the best approach is to employ a video quad that will provide up to four camera images to the train operator simultaneously. Each of these four images will be smaller scale, full-screen images rather than half-screen images as provided by the screen splitter. This technique divides the screen into four images of equal size and area—image size is decreased by a factor of four. For example, a quad image presented on a 10-in.-diagonal monitor will consist of four 4- by 3-in. images. Although some detail will be lost because of the reduced image size, this can be compensated for by using a larger monitor or reducing the distance between the viewer and the screen. The quad-image approach is most suitable for cases where the monitor is mounted on the rail vehicle. Most quad-image combiners digitize the incoming video signals and combine them into the output image. This allows synchronization and color subcarrier phasing differences among the four images to be compensated for during the combining process. As a result, the synchronization and color phasing compensation required with a screen splitter are not required with the quad-image combiner.

### Component Selection Guidelines

Although the system architecture defines the functionality and suitability of a CCTV-based observation aid, the components determine performance quality. CCTV system

components should be obtained from reputable suppliers with significant installation bases. In addition, these components should have accrued sufficient operating hours so as to support meaningful reliability statistics.

Because most CCTV equipment is employed in applications such as security where reliability is critical, these statistics should be readily available. In selecting CCTV components, a transit system's experiences with CCTV equipment should also be considered. The following paragraphs discuss specific considerations that should be addressed when selecting individual components for a CCTV-based door observation aid.

#### Video Cameras

The video cameras are the most significant element in a CCTV system because they define overall image quality and resolution. There are numerous decisions to make when selecting CCTV cameras. The following paragraphs address each decision and provide decision-making criteria.

*Camera Imaging Device.* The most significant advance in video cameras during the past 10 years has been the emergence of cameras that use semiconductor chip technology for color and monochrome applications. These chip-based cameras have essentially replaced the older vidicon tubes. The emergence of chip-based cameras has brought about significant advancements in camera size, durability, and performance. Specifically, chip-based cameras include those that employ charge-coupled-device (CCD) and metal oxide semiconductor (MOS) technology as the image sensing device.

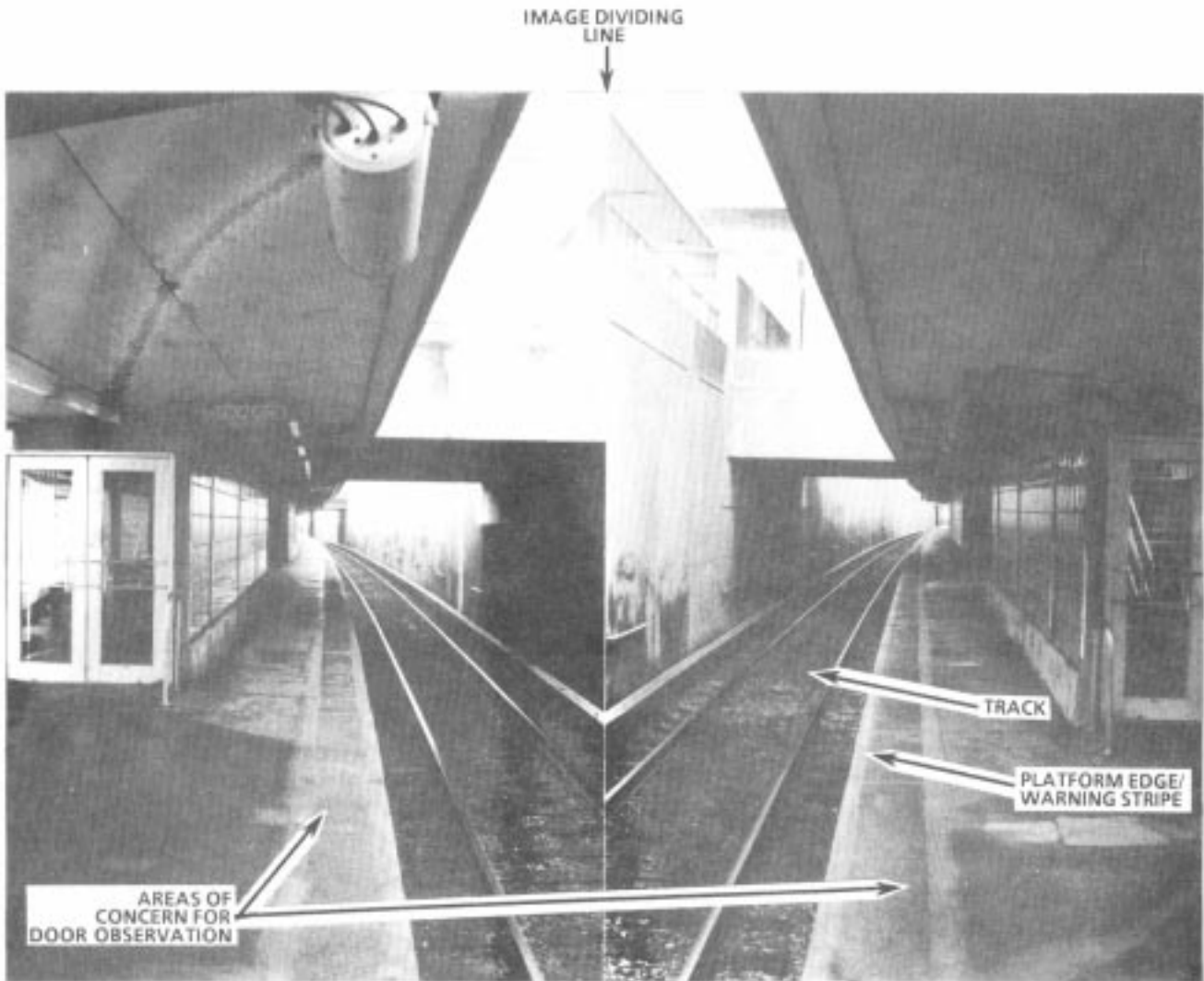

Figure 35. Split-screen image presentation.

A benefit of the chip-based camera is reduced camera size. This allows them to be installed in more covert locations and to use smaller and correspondingly less expensive versions of accessories such as environmental housings. Additional benefits have been realized in performance. Relative to the tube-based cameras they replaced, chip-based cameras offer equivalent low-light performance and resolution. In addition, the chip-based cameras eliminated several problems that plagued tube-based cameras, including smearing, blooming, and burn spots. In addition, chip-based cameras eliminated geometric distortion; this makes them better suited to the door surveillance application, which is characterized by the converging lines presented by the platform edges and rail car sides.

The most significant benefit of chip-based cameras is that they have provided overall reductions in life cycle costs of CCTV systems—chip-based cameras have lower initial acquisition costs and offer increased levels of reliability. In general, chip-based cameras have mean-time-between-failure (MTBF) performance in excess of 40,000 hr.

Acquisition cost savings are a direct result of the significant rise in the consumer camcorder market, which dramatically expanded the production base for chip-based video imaging devices. As a result, chip-based cameras are widely used and have proven reliable in various applications.

*Resolution.* By definition, a standard NTSC (TV) video image has 525 horizontal lines that constitute the video image. Not all of these lines are used to provide the visible portion of the image. The greater the number of lines used of this total, the greater the resolution of the image presented. Currently, available color CCTV cameras range from 320 to 470 lines of resolution with 330 lines being nominal.

Monochrome cameras range from 240 to 570 lines with 380 lines being nominal. On the basis of the imaging requirements of the door observation application, cameras with nominal line resolution provide sufficient performance (i.e., 330 lines for color, 380 for monochrome). When selecting a monochrome



camera, it is important to consider the number of shades of gray it can image. The greater the number of shades of gray that a camera can image, the better the resolution. There is a trade-off here between shades of gray and lines of resolution—it is better to use a camera that provides slightly fewer lines but will capture more shades of gray than a camera with a large number of lines of resolution that produces few shades of gray.

In specifying the resolution of a CCTV system, the video monitor to be used must be considered in conjunction with the camera. Generally, the smaller the monitor to be used, the fewer lines it will be able to display. For example, color 9-in.-diagonal monitors can display an average of 300 lines, while 19-in.-diagonal monitors can display an average of 400 lines. Similarly, 9-in.-diagonal monochrome monitors can display an average of 700 lines, while 19-in.-diagonal monitors can display 800 lines.

Although there is a significant difference in the resolution of color and monochrome systems, the resolution provided by the color systems is suitable for the task of car door observation. This was proven during the demonstration performed at PATH where the color CCTV system (consisting of 330-line resolution cameras and a monitor of equivalent resolution) was tested. During this demonstration, the images produced were sufficiently detailed to verify that the doors were clear; however, the images presented of small details, such as the door indicator lights on the side of the car, were not totally sharp. If the CCTV system will be used to verify the status of indicator lights, a higher resolution (i.e., a 400-line minimum) color CCTV system should be used. On average, the cameras for the higher resolution system will cost approximately 20 percent more than nominal resolution cameras. In addition, a larger monitor (a 14-in.-diagonal minimum) must be used in order to display the required detail.

*Exposure Performance.* The most significant factor influencing the performance of a CCTV camera is its ability to collect images under varying light conditions. Factors influencing this ability include low-light performance and exposure control. The low-light performance defines the minimum level of light needed to collect a viewable image. Exposure control is a measure of the camera's ability to respond to varying light conditions. A related factor is the uniformity of the lighting level in the area being viewed; this is more a function of facility characteristics and is often best addressed through the use of multiple cameras.

Specification of the low-light performance for a camera is based on the system lighting standards. For cameras, this is specified in terms of lux, which is an international system unit of illumination, where 1 lux is equal to 1 lumen per square meter. For comparison purposes, 10 lux is equal to 1 fc, which is the most frequently used measure of illumination.

Generally, the systems visited and those that responded to the questionnaire indicated that the minimum lighting levels employed 5 lux (0.5 fc) as the standard. The researchers found that most facilities are actually operating at an average level that is much higher. For example, the minimum level observed in PATH's Journal Square station during the CCTV

demonstration was approximately 20 lux (2 fc) while the average lighting level on the station platform was approximately 60 lux (6 fc).

The minimum illumination required for monochrome cameras is nominally less than that required for color cameras; therefore, monochrome cameras provide better low-light performance, regardless of cost. Monochrome cameras are available with minimum illumination performance ranging from 0.0003 to 9 lux. The average price and performance monochrome camera will provide low-light performance on the order of 1 lux (0.1 fc), which far exceeds the needs of all transit properties. Color cameras provide low-light performance ranging from 0.09 to 20 lux. The performance of these cameras is generally lower because of the light level required to discern colors. A color video camera of average price and performance will operate at 3 lux (0.3 fc), which again far exceeds the requirements.

When assessing the low-light-level performance, the optical speed of the lens selected must also be considered. The optical speed of the lens is a measure of its ability to gather and pass light. The more light that passes through the lens, the better the contrast and quality of the image. The figure of merit used for this measurement is the f number where:

$$f = \text{lens focal length} / \text{lens opening diameter (iris)}$$

Generally, manufacturers provide camera low-light performance specifications based on the use of a "fast" lens such as f1.4 or f1.6. Slower lenses have f numbers of f4 or greater. Faster lenses are larger, particularly in diameter, and cost more than slower lenses. In general, the faster lenses cost 30 percent more than a comparable slow lens. For this reason, it is important to select a lens and camera combination that will provide the required level of performance. Often this involves cost versus performance trade-offs between the camera and lens. For example, a camera with better low-light performance and a slow lens may be more cost-effective than the opposite situation.

Exposure control in a lens is defined by how the lens and camera body combination regulates the amount of light that reaches the imaging device. The mechanism used to regulate the light level is referred to as the iris. Cameras have fixed or auto irises. Because of their greater complexity, cameras with auto irises cost approximately 15 percent more than fixed-iris cameras while auto-iris camera lenses cost about 40 percent more than fixed-iris lenses.

A fixed iris is used when the level of ambient lighting does not vary significantly. An example of this is a platform in a subway station where all lighting is artificial. For cameras with a fixed iris, the opening is manually set during installation and remains that way unless the setting is changed.

With automatic iris control, the camera will continually adjust to compensate for varying light conditions. Because the lighting conditions for surface and elevated stations vary greatly with the time of day, regardless of artificial lighting, auto iris is essential for such locations.

The research team observed that the lighting level changes when a train is in the station. This is because of the contribution of the train's interior lights and reflections off the bare metal

**TABLE 4 CCD camera imaging element dimensions**

Format	Diagonal	Horizontal	Vertical
1/3 in.	16.0 mm	12.8 mm	9.6 mm
1/2 in.	11.0 mm	8.8 mm	6.6 mm
2/3 in.	8.0 mm	6.4 mm	4.8 mm
1 in.	5.5 mm	4.4 mm	3.3 mm

or lightly colored sides of the rail car. In some cases, this difference was enough to cause relatively significant changes in the platform ambient light level. This situation occurred at stations with relatively low ambient lighting levels, such as those of WMATA in Washington, DC. In this case, the lights inside the rail car contributed significantly to the platform illumination when the doors were opened.

During CCTV system design, tests using a light meter should be conducted to determine if lighting levels change significantly when a train is in the station. If the changes are relatively small, a fixed iris will be acceptable; however, it should be set to accommodate conditions when the train is in the station. If the changes are large, an auto iris camera should be used.

*Camera Format.* Video cameras are available in various formats. The most common formats are 1/3 in., 1/2 in., 2/3 in., and 1 in. Formats are determined by the size of the camera's imaging element. Several cameras do not specify format but provide the dimensions of the imaging element in millimeters. Table 4 provides the dimensions of the imaging element for each of the four common CCD camera formats.

Most 1-in. format cameras are vidicon-tube-based and are falling out of use. Correspondingly, technology advances have led to a shift to cameras with smaller imaging devices, with 1/3-in. and 1/2-in. cameras being the most commonly used for new applications. The 1/3-in. format is fairly new and is gaining in use and, while smaller in size, provides equivalent performance because of enhancements in sensing-device technology. In reality, any of the formats will provide high-quality results at competitive prices. The overriding criteria used in selecting a particular camera should be its resolution and low-light performance.

*Camera Lens.* In addition to the optical speed and iris controls discussed above, the field-of-vision provided by the camera must be considered. This field-of-vision is directly related to the focal length of the camera lens used and is influenced by the camera installation design discussed above. Once the required field-of-vision has been determined, the appropriate lens can be selected. Although it is possible to calculate the focal length on the basis of a camera format and field-of-vision requirement, several camera and lens manufacturers provide a wheel type calculator that accomplishes this very quickly. These calculators are readily available at no cost from most lens manufacturers and distributors of CCTV equipment.

Because fixed-focus lenses are only available in selected focal lengths, the selection process is often a compromise; however, this compromise can be addressed successfully by adjusting the camera location to compensate for the field-of-vision variation. Where it is necessary to make this compromise, it is better to select a shorter focal length lens with a wider field-of-vision to avoid missing portions of a scene. Although variable focus lenses are available that allow the use of a precise focal length, they are expensive and should only be used if absolutely necessary.

The lens required to provide a given field-of-vision varies with the camera format. Although both horizontal and vertical fields-of-vision are specified, the vertical field-of-vision is not of significance because the lens must only see from the mounting point down to the platform level. In general, an appropriately selected horizontal field-of-vision will provide a sufficiently large vertical field-of-vision. The exception to this case is for conceptual systems where the equipment is car-mounted. In this case, the vertical field-of-vision must be selected to allow the camera to see the set of car doors nearest the camera. Table 5 provides lens focal length and field-of-vision combinations for various commonly available lens focal lengths and camera formats.

This listing makes clear that as the focal length of the lens gets larger, the field-of-vision becomes more restricted. Generally, lenses with a focal length greater than 8mm are not suitable for rail car side-door observation aids.

#### *Camera Enclosures*

Except for the most benign environments, camera enclosures are a necessity. Enclosures protect the camera and lens from the effects of the weather for surface and elevated installations; they also protect the camera and lens from vandalism. Generally,

**TABLE 5 Camera angular field-of-vision (degrees)**

Lens Focal Length (mm)	1/2 in.		1/3 in.	
	Sensor Horizontal	Vertical	Sensor Horizontal	Vertical
3.5	84.6	67.8	61.3	48.5
4.0	76.8	60.5	56.0	42.7
4.8	66.4	51.8	47.5	36.0
6.0	55.7	42.6	39.0	29.0
8.0	43.5	32.5	29.7	22.2
8.5	41.1	30.9	28.0	20.8
12.0	29.5	22.0	20.0	14.6
12.5	28.6	21.5	19.4	14.3
16.0	22.5	16.7	15.2	11.3
25.0	14.5	10.5	9.6	7.2
35.0	10.3	7.6	6.9	5.1
50.0	7.3	5.3	4.8	3.5
75.0	4.8	3.6	3.2	2.4

enclosures are constructed from plastic, aluminum, or stainless steel. For most applications, aluminum housings will protect the camera adequately.

Although it is possible to use plastic, the difference in price relative to aluminum is so small that aluminum has a better price-performance ratio. Stainless steel enclosures are designed for use in highly demanding applications, such as the cameras used by NASA to view space shuttle launches, and monitoring of industrial processes, such as steel making. Although they provide high protection, they exceed the real environmental requirements of mass transit applications.

When selecting a camera enclosure, the basic rule is to ensure that, at a minimum, the enclosure will comply with the requirements of the National Electrical Manufacturer's Association (NEMA) Specification 4. This specification defines an equipment enclosure for indoor or outdoor use that provides protection from splashing water, windblown dust or rain, and hosedirected water. In addition, these enclosures will not be damaged by the formation of ice on the enclosure. The same specification applies to enclosures used for signal processing and transmission equipment on surface or elevated platforms. For equipment enclosures used in subway locations, NEMA 12 should probably be used because this equipment will probably be in an off-platform equipment room with other electrical machinery. NEMA 12 enclosures are designed for indoor use and provide protection from dust, falling dirt, and dripping noncorrosive liquids.

Camera enclosures may offer options to provide added environmental protection, including thermostatically controlled fans and heaters to maintain the temperature level inside the enclosure, double-glazed front windows to provide resistance to condensation formation, and sunshades to protect the lens from direct sunlight exposure. In the case of heaters, they commonly dissipate 60 watts and turn on when the temperature drops below 40° F and turn off when the temperature reaches 50° F. Camera enclosure blowers circulate approximately 22 CFM of air and turn on when the temperature rises above 90° F and turn off when the temperature drops to 80° F.

#### *Mechanical Camera Installation*

In addition to the camera positioning considerations addressed previously, the camera should be securely mounted to a station or platform structural member. To prevent vandalism, cameras, their enclosures, and their brackets should be mounted out of passenger reach.

Several firms manufacture standard and custom camera mounting brackets that provide cost-effective solutions to the issue of mechanical camera mounting. Mounting brackets will need to support the weight of the camera, lens, and enclosure. An average combined weight for these three items is about 25 lb, assuming the enclosure options described above (e.g., heater and fan) are employed. When mounting the bracket to a station structural member, a fastener with a minimum pull out strength of 1,500 lb should be used.

#### *Lens Filters*

For elevated and surface stations, the ambient lighting conditions will change during the day. These conditions will range from bright sunlight to artificial light during evening

and night hours. During certain periods of the day, significant glare and reflections can cause a camera to saturate with light, thereby virtually eliminating all contrast and detail in an image.

The researchers found that this situation occurs predominantly at sunrise and sunset, when the sun is at low angles relative to the horizon. During these periods, the sun can be nearly perpendicular to the sides of the rail car, thereby causing maximum reflection and glare. In addition, low sun angles may mean the camera is pointing directly at the sun.

Generally, cameras will be angled slightly down toward the station platforms; however, every effort should be made to ensure that the camera does not point into the sun at any time. Changes in season compound the problem of sunlight flooding camera lenses. The conditions for each surface station must be evaluated because the conditions and problems reflect factors such as the geographic orientation of the station and the nature of the station and surrounding structures.

A potential method for overcoming problems because of glare and reflection is to employ polarizing filters on the camera lenses. Natural light consists of several components of equal amplitude with the components in planes at right angles to the line of propagation. Some of these components contribute to the required ambient lighting while others produce undesirable glare.

A polarizer will block selected components while allowing others to pass. The material used to polarize light is characterized by an optic axis. The ability of the material to transmit light is greatest in the direction at right angles to the optic axis. Conversely, it is the lowest on a path incident to the optic axis. Light is polarized by moving the polarizing material until the optical axis of the material is coincident to the line of propagation of the glare light. Polarizers will restrict the amount of light that reaches the lens; however, this only occurs where the light is coincident with the optical axis of the polarizing material. At other times, the polarizer will not restrict the light reaching the lens. For these reasons, polarizers are best used with auto-iris cameras as described above.

#### *Monitors*

In addition to the cameras, the monitor plays a significant role in determining the contrast and resolution of video images. As introduced during the discussion of camera resolution, the monitor should have a resolution in TV lines equal to or greater than that of the cameras. An additional consideration is geometric distortion, which should be less than 5 percent. Because a door observation aid will show platform edges and car sides that are straight lines, geometric distortion greater than 5 percent will become obvious.

The size of the monitor should be as large as is possible for the specific application. A basic rule governing monitor sizes is that the minimum viewing distance from the monitor in ft ( $\pm 25$  percent) should be no more than the diagonal size of the monitor minus 4 in. For example, during the CCTV demonstration at PATH, a 9-in.-diagonal monitor was used. Using the rule, the monitor was positioned so that it was within the calcu-

lated range of 3.75 to 6.25 ft from the conductor's position. Generally the monitor was about 6 ft from the conductor's position. When asked about the size of the image, the most common complaint was that the monitor was too small. The monitors used by MTA-NYCT were approximately 13 in. in diameter and located no more than 6 ft from the conductors position. Applying the rule stated above to the 13 in. monitor, the viewing distance should be in the range of 6.75 to 11.25 ft. None of the MTA-NYCT conductors indicated that the monitor was too close and most indicated that the viewing distance was comfortable.

With this in mind, the researchers recommend revision of the rule stated above to bring the monitor closer to the conductor or make the monitor larger. A rule to apply to this situation is to make the monitor a minimum of twice the viewing distance with 2.5 times the distance being most desirable.

Monitor size is a consideration when a quad-image display format is used. As described previously, a quad-image combiner takes the images from four cameras and presents them in a single display. Each of the images occupies a quarter of the monitor screen. For a 10-in.-diagonal monitor, each of the four images will be 5 in. diagonally. For these images, the best viewing distance is between 9 in. and 15 in.. As a result, use of a quad display is best suited to cab-mounted rather than platform-mounted monitors. Equipment space in the cabs of transit vehicles is often very constrained; this often would preclude the use of a larger monitor. In this case, the only solution is to have the monitor as close as possible to the viewer.

A potential problem with platform-mounted monitors arises from variations in train stopping points. By design, the monitor is located so that the train crew can see it when the train is properly berthed. Because there can be variations in stopping points of up to  $\pm 5$  ft, the monitor should be placed so that it can be viewed even if the train misses the nominal stopping location.

Under ideal circumstances, a person viewing a monitor should be directly in front of it. As the viewer moves to the right or left, the viewing angle increases and it becomes increasingly hard to interpret the image. One approach to minimize the effects of the change in viewing angle is to set the monitor back. Figure 36 illustrates the differences in viewing angle. The viewing angle can be calculated using the formula:

$$\text{Viewing angle} = \arctan(\text{stopping variance}/\text{monitor setback})$$

With the monitor set back 3 ft from the viewer and a stopping position variance of 5 ft, the viewing angle will be approximately  $60^\circ$ . With this viewing angle, it may be difficult for the viewer to interpret the image, particularly when a split-screen or quad-image display is used.

With the monitor set back 6 ft and a 5-ft stopping point variance, the viewing angle will be  $40^\circ$ , which, although not nearly optimal, is a significant improvement. In positioning the monitor, a transit property should attempt to keep the viewing angle less than  $30^\circ$  under all circumstances. It is also important to apply the monitor size rule described above when choosing the installation location.

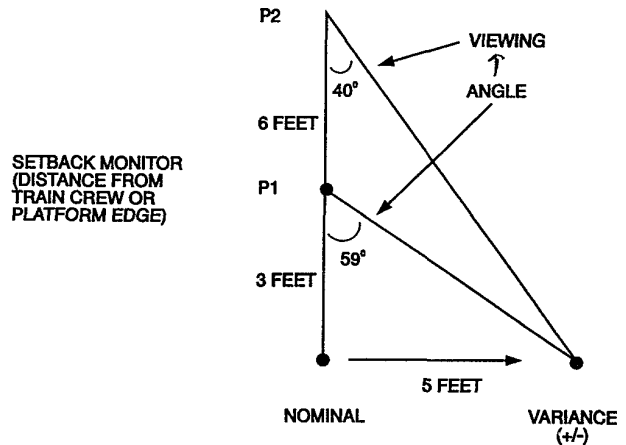

Figure 36. Monitoring viewing angle variance.

### Video Transmission Links

Previously in this report, alternatives for video transmission links were reviewed. The primary criterion used in selecting a video transmission link concerned the electromagnetic environment of the area where the system operates. Firms that specialize in performing surveys to assess the environment can identify interference sources. This information can be used to decide on licensed or unlicensed approaches and specific frequencies.

During the CCTV demonstration at PATH, an unlicensed transmission system operating at 916 MHz was tested. Generally, the system produced clear images, without interference, within the desired reception range. The only interference observed was some snow when the train started moving. This interference was probably related to transient noise associated with the vehicle propulsion system. Although perceptible, this interference did not degrade the usability of the image. The researchers also tested the same equipment on other transit systems and did not experience any interference.

The best way to select a transmission methodology is to test various alternatives. RF transmission equipment suppliers will assist in these tests by loaning equipment for tests or by having their own personnel visit the transit property. If such tests are performed, they should be conducted at all locations where the equipment will be used—this way, sources of interference localized to a single station can be identified and the problem can be studied.

### System Interconnection Cables

Regardless of the system architecture, a CCTV-based observation aid requires interconnection cables. Depending on station characteristics and system designs, cable runs can be hundreds of ft. long. For this reason, the interconnection cables selected must provide the smallest possible attenuation of the video signals. CCTV equipment is designed to be interconnected using 75-ohm coaxial cable. If cable rated other than

**TABLE 6 Coaxial cable performance characteristics**

Cable Type	Resistance	Maximum Per 1000 Ft (Ohms)	Cable Run
		Best Image	Good Image
RG-59/U	15 ohms	400 ft	820 ft
RG-6/U	7.5 ohms	530 ft	1,100 ft
RG-11/U	2.6 ohms	820 ft	1,600 ft

75 ohms is used, excessive line reflections and signal loss will occur.

Video interconnection cable has several characteristics that determine its performance. Included among these are the core conductor material, dielectric material, shield construction and cable jacket material. These characteristics should be matched to the application and the environment. Some general rules that apply are as follows:

- Foam dielectric material (cellular polyethylene) offers the best performance; however, it is susceptible to absorption of moisture, which reduces its effectiveness. Where cable will be used outdoors, a solid dielectric cable (polyethylene) with a heavy insulation jacket should be employed. This applies to both outdoor and indoor applications.
- To prevent crimping of the shield, the cable should not be subjected to sharp bends.
- Only cable with pure copper stranding should be used. Although copper-plated steel stranding is available and less costly, its performance is substandard because its transmission bandwidth is limited.

Three types of coaxial cable are commonly used in CCTV systems. Generally, the difference among these cables is the conductor resistance, which, in effect, determines the maximum cable run that can be used without amplification. These cable types include RG-59/U, RG-6/U, and RG-11/U. Table 6 provides the conductor resistance of each type and the maximum cable run for which each type can be used without amplification.

For most applications, RG-59/U will be suitable; however, long platforms or equipment rooms remote from the platform may require use of one of the alternatives. Of these cable types, the RG-59/U is the least expensive—the others are approximately 1.8 times the cost (for RG-6/U) and 3 times the cost (for RG-11/U).

#### *General Equipment Selection Considerations*

In addition to the functional performance of the equipment in a CCTV system, the environmental specifications must be considered. These specifications include temperature,

humidity, shock, and vibration. These are functions of local conditions at the installation site and need to be verified before selecting components.

Generally, commercially available CCTV components will operate with ambient temperatures in the +14 to 122° F (-10 to +50° C) range and humidity (noncondensing) of less than 90 percent. This should provide sufficient performance for all subway applications; however, surface and carborne installations may be problematic. In these cases, the equipment enclosure and vehicle structure will provide additional protection. If necessary, heaters and blowers can be used for camera enclosures as described above.

Shock and vibration are significant factors to consider for all carborne equipment. Platform-mounted equipment will not be subjected to measurable shock or vibration under normal circumstances. Equipment to be installed on a rail vehicle should be able to withstand shocks transmitted to it through the vehicle structures during normal operations. As a result, this becomes a function of the design and condition of the rail vehicles, the condition of the tracks, and operating methodologies.

## **MIRRORS**

### **System Application**

Mirrors are the most widely used rail car side-door observation aid in the transit industry. They provide a low-cost, highly reliable method to assist train crews in providing safe and efficient door operation. Mirrors have enjoyed widespread acceptance among train crews. This is a direct result of the simplicity of mirrors, their ease of use, and that they can be integrated into transit operations rapidly.

The following paragraphs address basic functional and operational guidelines for using mirrors to observe car side doors in transit systems. Recommendations for the general approach to be used in the application of the devices is also discussed. These guidelines are general and require review and possibly tailoring for application to a specific transit system.

Mirrors operate by projecting an image through reflection of light rays off a reflective surface. When the reflective surface is at an angle other than perpendicular, the light rays will reflect away from the light source. Figure 37 illustrates the basic operating principles of a mirror. In this figure, the angle of incidence from the light source to the mirror,  $i$  and  $i'$ , are equal, respectively, to the angles of reflection away from the mirror,  $r$  and  $r'$ . For a flat or plane mirror, each image point is similarly located and the complete image can be readily viewed. There is a direct, fixed relationship between the viewer's location and the field-of-vision provided by the mirror.

As shown in Figure 38, for a person viewing a mirror located at a fixed point ( $BM$ ), the field-of-vision depends on the width of the mirror and the mirror offset angle relative to the operator. For a constant mirror size and offset angle, there is a reduction in the field-of-vision provided by the mirror as the mirror is drawn away from the operator's location ( $SM$ ). In general, a

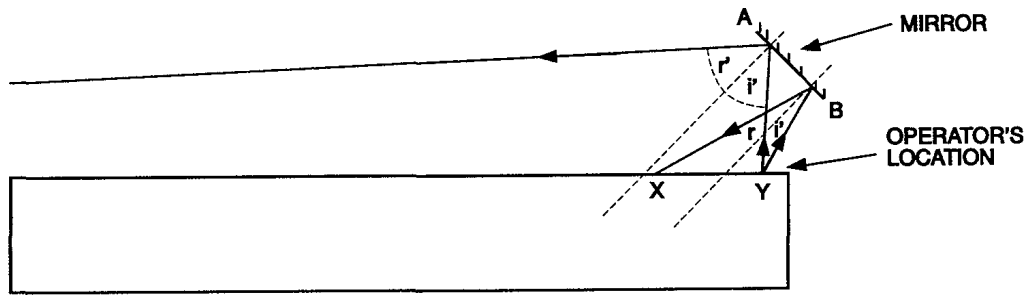

Figure 37. Mirror reflection principles.

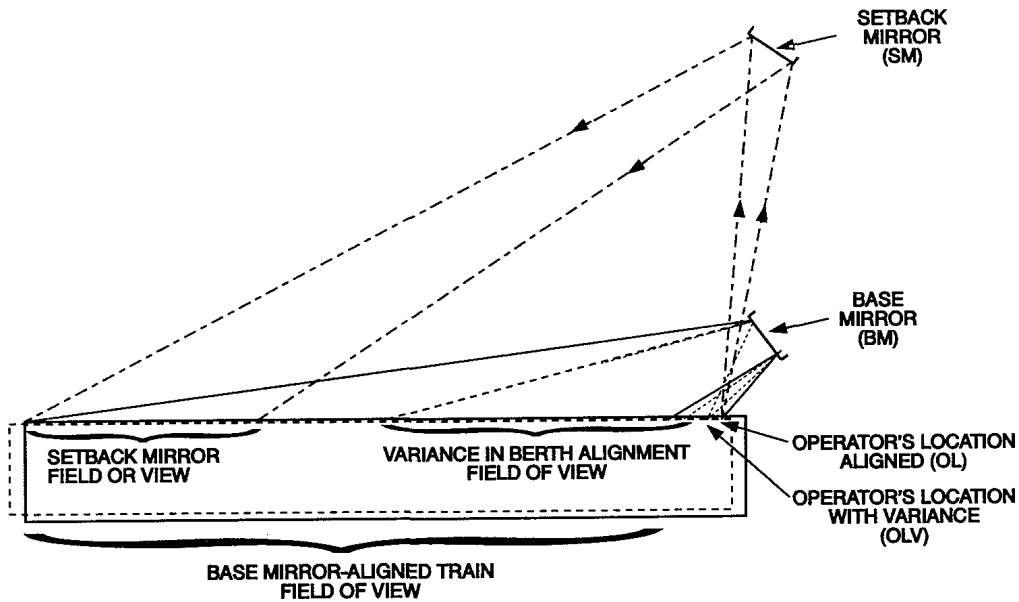

Figure 38. Mirror field-of-vision vs. setback.

mirror should be as close as possible to the viewer, while still providing the required field-of-vision.

During the transit property site visits, researchers observed that there is variation in the stopping location for trains and corresponding variances in the viewer's position relative to a platform-mounted mirror. This changes the offset angle of the mirror relative to the operator's position and results in narrowing the field-of-vision when the relative offset angle is increased—as occurs when the train stops short of the nominal stopping position (point *OLV*). In this circumstance, the field-of-vision may become so narrowed that critical features of the rail vehicle cannot be seen in the mirror. When the train stops past the nominal stopping position, the field-of-vision will increase, but the operator's mirror viewing angle will approach 90°, making the image harder to discern. If the train stops far enough past the stopping location, this angle becomes obtuse, rendering the mirror unusable.

For a convex mirror, the angle of incidence also equals the angle of reflection; however, the reflective surface is curved, not planar. As shown in Figure 39, this curvature provides a much larger range of viewing area for the operator's location, as opposed to a flat planar mirror. As a result, the mirror offset angle can be greater (approaching 90° or parallel to the side of the rail vehicle) to align the limits of the field-of-

vision with the rail vehicle. However, a convex mirror creates a compressed image of a reflected object because of the vertical and horizontal curvature of the mirror—the images are smaller and details are harder to discern. In this respect, a rectangular convex mirror that curves across the width of the mirror but is planar along the height may be desirable. Such a mirror will minimize the vertical compression of the image, thereby making details easier to discern.

The generally wider field-of-vision means that the view provided by convex mirrors is not affected significantly by variations in berthing locations. If a rail vehicle stops short of the defined location, the operator can still observe the required field by observing the image on a slightly different part of the mirror. The operator can make a similar adjustment if the vehicle stops past the berthing location. When designing a convex mirror installation, variations in stopping locations can be accounted for by having the mirror provide a wider field-of-vision than that required for a single stopping location.

### Mirror Design and Construction

The many different types and sizes of mirrors available from qualified suppliers include flat, convex, concave, and dome.

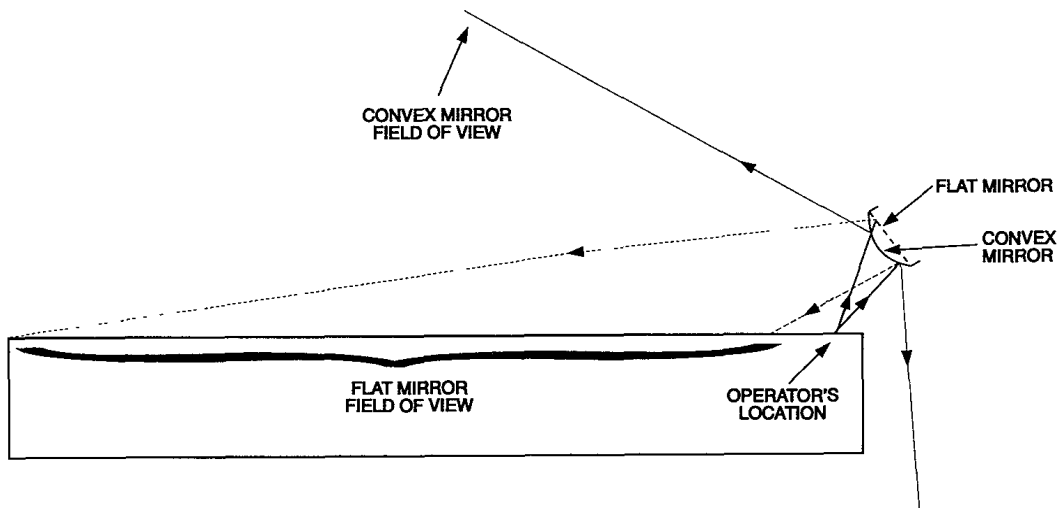

Figure 39. Convex vs. flat mirror field-of-vision.

Various configurations and sizes of each type are available to meet specific imaging requirements. The more common flat mirror shapes include rectangles and circles. Convex mirrors are generally circular, although convex rectangular configurations are used for particular requirements as described above.

In addition to different sizes and types, mirrors are available in various materials to meet specific operational or functional requirements. Although glass is common in residential and commercial use, the high potential for breakage makes its use for transit applications unacceptable.

Most transit applications use plastic-based materials in the construction of the mirror. This provides a relatively high degree of resistance to breakage and minimizes associated hazards. Although the clarity obtained from glass-based mirrors is generally thought superior, plastic-based mirrors provide excellent, undistorted images.

Another type of commercially available mirror is based on polished steel. Although technically very rugged, especially under extreme industrial applications, the reflected image on the mirror is not as crisp or clear as images on glass or plastic because of imperfections arising from the plating process used to create the reflective surface.

**Platform-Mounted Mirrors—Usage Guidelines**

*Mirror Selection*

The selection of a flat or convex mirror to assist in the observation of rail car side doors is affected by several operational and physical constraints. Convex mirrors are the most common rail car side-door observation aid in use within the transit industry. Although they compress the image, convex mirrors provide a field-of-view over a wide area, are not affected by nominal variances in berthing locations, and are readily adaptable to considerable variances in operator height. They are used in roughly 95 percent of all locations where transit properties use mirrors.

For very specific operational and functional requirements, a flat mirror will provide an operator with an enhanced

TABLE 7 Comparison of flat vs. convex mirrors

FLAT-FACED MIRROR	
Benefits	Disadvantages
Enhanced image for large depth of field	Smaller relative field-of-view
Limited adaptability to berthing deviations	Installation alignment more critical
CONVEX-FACED MIRROR	
Benefits	Disadvantages
Increased field-of-view	Smaller relative image
Adaptable to variations in operator positioning	

image of a particular observation situation. Table 7 provides basic criteria to guide the general selection of a mirror type.

The initial acquisition cost of a convex mirror is only slightly more than that of a flat mirror. The installation costs for the two types are comparable, with the only significant difference being the degree of adjustment required to produce a suitable image on a flat mirror. Sometimes the advantages of a flat mirror may outweigh those of a convex design. The primary advantage of a flat mirror over a convex is the larger relative image size that is projected. When the observation is conducted over a long distance, the size of a projected image is very important in enabling an operator to distinguish between objects and passengers, and as such, a flat mirror provides a distinct advantage. During the demonstration at PATH, the

researchers performed a side-by-side comparison of a flat and a convex mirror. This comparison verified the difference in the image size and, although the flat mirror had a narrower field-of-vision, it provided a better image of the rear of the train.

For a flat mirror to be the most beneficial, it should be used in applications requiring only a limited field-of-vision and where there are minimal variances in berthing locations. This is generally a limited scenario, because the berthing locations can vary considerably (for manual operation,  $\pm 5$  ft) and the required field-of-view to be observed is considerably larger than that provided by the flat mirror.

One variation on the use of a single flat mirror is to employ two flat mirrors side by side. When these mirrors are properly aligned, the field-of-view is increased, which allows a greater variance in the berthing location. Another variation is the use of a flat and a convex mirror; however, the flat mirror would be primarily configured to handle a special area of increased observation. A third variation would be the application used by Toronto's TTC on its heavy rail lines. On TTC, the mirror is mounted flat on the wall at the exit of the train station close to the edge of the platform. This mirror is used by the train conductor to sight along the side of the train as it leaves the station in order to detect dragging incidents.

#### *Mirror Dimensions*

Platform-mounted mirrors should be as large as possible so as to provide the largest field-of-view and image size to the operator. Although circular convex mirrors are the most commonly used, rectangular mirrors are available. Practicality dictates that a circular convex mirror be approximately 18 to 24 in. in diameter and that a rectangular convex mirror have similar dimensions. During the site visits, both circular and rectangular flat mirrors were observed. Advantages of one over the other generally depend on physical limitations on installation or positioning or the required field-of-view. Again minimum dimensions should range from 18 to 24 in.

#### *Mounting Location*

Several factors must be considered when selecting where to install mirrors. These factors include the distance between the mirror and the operator and the height of the mirror above the platform. The primary requirement is to maximize the required field-of-view presented to the operator. The distance that the mirror is set off from the platform edge is a function of the curvature of the platform edge, the location of any platform-based obstructions, or both. Consideration should be made for exposed platforms, because precipitation collecting on the face of a mirror limits its effectiveness. Lighting conditions should be evaluated to ensure that foreground or background lighting does not limit the operator's ability to see the images on the mirrors.

The optimum height for a mirror above a platform surface is a compromise of the ability of the mirror to provide images of the car side doors when the platform is crowded, the physical ability of an operator to view the mirror from the

cab window without straining, and the clearance necessary for passengers to pass underneath safely. Ceiling height, obstructions close to the planned location of the mirror, or both may prevent placement in the best location. Placement to minimize accessibility by vandals should also be considered.

Generally an 18- to 24-in.-diagonal mirror located 4 to 5 ft from the operator provides an optimum balance between the field-of-view and the ability of an operator to detect images over long distances. This is true for flat and convex mirrors. If no restrictions exist, the optimum height is generally 8 to 9 ft above the platform surface. This recommended height balances observation of the car doors in crowded stations and the capability of an operator to view the mirror from the cab window.

#### *Installation Methods*

Installation of mirrors should be performed using rugged brackets and supports to minimize tampering and shifting of the mirror's position by vandals. This may require the use of special hardware or the tack welding of nuts and bolts. For ceiling-mounted mirrors, the brackets should be securely attached to non-flexing structural members of the platform canopy or building structure.

For platform-mounted mirrors, the brackets should be secured to rigid, nonflexing, and nontwisting columns that are resistant to vandalism.

### **Vehicle-Mounted Mirrors—Guidelines**

Because vehicle-mounted mirrors increase vehicle dimensions and because right-of-way clearances on most heavy rail operations are tight, vehicle-mounted mirrors are generally used only on light rail vehicles. Vehicle-mounted mirrors are necessary for the observation of car side doors when the train is operated by a single crew member and when the cab configuration prevents the operator from readily observing the side of the train. For light rail vehicles that interact with vehicular traffic, the use of side mirrors also enhances safe vehicle movements at street level.

#### *Mirror Selection*

As with platform-based mirrors, two types of carborne mirrors can be and are employed by transit systems. Generally, the selection criteria provided in Table 7 apply. Flat mirrors are most extensively used to provide images along the sides of the vehicles. Although they provide a relatively clear image along the side of the cars, the overall field width is generally limited and little visibility of passengers approaching the doors is provided.

To increase the width of the field-of-vision, several authorities have installed approximately 4-in.-diameter convex mirrors under the flat mirrors. This is standard procedure in the trucking industry, which also encounters obscured vision along the side



of the truck. Although increasing the size of the field-of-vision, the compression of images by convex mirrors limits the ability of an operator to distinguish among the observed shapes, particularly when an object is in the doorway. It is recommended that both types of mirrors be installed to enable an operator to observe both the doors and the area in front of the doors. The Baltimore MTA's light rail operation uses both convex and flat vehicle-mounted mirrors in conjunction with platform-mounted convex mirrors—the resulting visibility of the vehicle sides was found to be the best of all the light rail operations visited during the research.

### *Mirror Dimensions*

Carborne mirrors mounted on the exterior of the vehicle should be as large as is practical. During the selection process, the first step should be evaluation of the right-of-way clearances to determine the maximum size allowable. With this information in hand, the mirror size can be selected.

Care must also be taken to ensure that the mirror does not protrude from the car so that a passenger standing on the edge of the platform could be struck by the mirror as the train enters the station. Generally, this will not be a problem for high-floor light rail vehicles, but may be a problem with the new generation of low-floor light rail vehicles.

Generally, a flat, rectangular mirror with approximate dimensions of 6 by 12 in. is found on most types of transit vehicles with carborne mirrors. Although the field width is limited, the image provided to the operator allows a clear line-of-sight along the side of the vehicle. A 4- to 6-in.-diameter convex mirror located with the rectangular mirror increases the field-of-view to include passengers approaching the vehicle and provides visibility around selected obstructions.

### *Mounting and Adjustment*

Both the flat and convex mirrors should be mounted at the corners of the operator's cab to provide the greatest possible field-of-vision. When calculating the projection of the mirror from the side of the train, 3 in. should be added to the width of the mirror to account for mounting brackets. For example, a 6-in.-wide mirror will project approximately 9 in. from the side of the vehicle. The vertical center of the mirror should be as close as possible to the eye level of an operator of average height. When determining the vertical height, it is important to ensure that the entire mirror will be visible to all operators. Generally, this may require shifting the mirror toward the top of the vehicle.

Mirrors should also be near operable cab windows and in a position that allows the operator to adjust the aid to suit his or her particular needs. If ready access is not possible, then motorized remote controls to provide mirror adjustment should be considered.

## **General Recommendations for Mirror Applications**

Mirrors provide substantial benefits in the observations of car side doors, especially under obstructed conditions. As

shown in the Merit Assessments Section of this report, mirrors provide a relatively high degree of functionality at a low lifecycle cost. Numerous factors must be considered when designing a mirror-based observation aid. Each of these factors must be considered carefully for each individual line and each station location. When major changes affect the operation of a line within a particular station, the guidelines for mirror application should be reevaluated to ensure that the optimum benefits continue to be derived.

Using multiple types of mirror applications may significantly increase the overall information provided to an operator. For heavy rail operations, the installation of combinations of flat and convex mirrors may increase observation capabilities under difficult operating scenarios. For light rail systems, the use of carborne mirrors and platform-mounted mirrors substantially increases observational capability versus systems operating with carborne mirrors only. An example of this is the Baltimore MTA's light rail operation. Part II of this report provides details of MTA's use of two types of mirrors.

Although maintenance of mirrors in general is not required, they should be inspected regularly for proper alignment and corrected as necessary. Cleaning should be performed regularly because dirt can and does accumulate on the face, which limits the operator's ability to see the door images.

## **SENSOR-BASED OBSERVATION AID USAGE GUIDELINES**

In Chapter 2 of Part I of this report, sensor technology was introduced as being viable for use in door observation applications. Although a demonstration was performed on Baltimore's MTA, more research and development are required before a system can be deployed. Regardless of this fact, the researchers' work has led to some conclusions regarding the use of sensors as an observation aid. The following paragraphs discuss the lessons learned to date regarding the use of sensors as an observation aid.

### **Application**

As discussed in Chapter 2 of Part I, door observation must address the area within the sweep of a rail car's doors as well as an area extending out from the doors. This latter area must be considered in order to ensure that passengers in motion will not be struck by or become lodged in the closing doors.

A wide variety of sensors are designed to assess motion and proximity. The technical maturity and commercial availability of these sensors suggests that the potential for sensor-based observation aids exists. Sensors have been used to control the automatic opening of doors in retail establishments and other public places for several years.

## **Sensor-Based Observation Aid Architecture**

The nature of the sensing requirements (presence and motion sensing) dictates the need for two separate types of sensors.

Although several types of sensors were considered, no sensor was able to sense these two properties simultaneously in a reliable fashion. In addition, the observation procedures described in Chapter 2 dictate that there is a time sequence associated with the sensing. Figure 27 illustrates such a time sequence. Further research is required to refine this timing sequence; however, it is a starting point. This research should focus on minimizing the time the sensor outputs will need to be interrogated to ensure that the doors are not recycled unnecessarily, thereby resulting in extended station dwell times and, in turn, schedule delays.

When the doors start moving, aids must be able to sense the presence of a passenger between the leaves of the door when the doors are closed or when the doors come into contact with a passenger. As the doors approach full closure, it is necessary to ensure that no passengers are in their path. Implementation of this time sequence dictates the need to interrogate the output of the sensors at different times and establishes the requirement for some form of controller to implement this timing sequence. These requirements resulted in the architecture illustrated in Figure 26.

Benefits can be obtained from integrating the door observation system with other vehicle systems. One example is the use of the door lock signal from the door control system shown in Figure 26. This signal informs the controller that the observation process is complete. In addition, the controller can send a signal to the door controller to recycle the doors when an obstruction is sensed. It is also desirable to integrate the system with vehicle voice announcement systems so that a warning message plays at the door area when an obstruction is sensed. Further research is required to define how these interfaces can be fully exploited.

## Sensor Technology

As developed in Chapter 2, Part I, of this report, the researchers reviewed several sensor candidates for the application. Although several were eliminated on the basis of preliminary evaluation, a few warranted further evaluation and were tested in the laboratory to assess their performance relative to the door observation aid application. Generally, these tests were performed by simulating rail vehicle structures and passenger movement patterns. These tests are described in Chapter 2, Part I, of this report.

The researchers identified two sensor types as being suitable candidates for the application:

- Microwave motion sensors and
- Photoelectric presence sensors.

Laser-based proximity sensors were also identified as being potentially suitable for the door observation application. Employing technology similar to that of moving beam scanners used in retail stores, these devices could be used to measure laser energy reflected off passengers and other obstructions. As of the writing of this report, this new technology had yet to be incorporated in commercial products. It was not possible to obtain a device to perform laboratory testing, so it was not possible to address this type

of device in this report. On initial evaluation, however, this technology appears promising and should be considered further as it matures.

Microwave technology has proven to be a highly reliable method for noncontact motion detection of persons and objects. This technology operates by detecting microwave energy reflected off an object. With motion sensors, shifts in the frequency of the microwave energy are detected according to the Doppler Principle. Because there is some potential for false alarms with motion detection, most of these devices require a minimum travel distance before a motion detection signal is generated.

Effectively, these devices average some number of Doppler cycles before producing a motion detection output. For the sensors evaluated in the laboratory, the minimum motion was approximately 3 in., which is sufficient for the door observation application. In addition, because motion detectors only sense motion toward the sensor, they will not be influenced by passengers walking parallel to the train. Finally, the motion detectors have a cone-shaped detection zone that can be oriented to observe a zone extending out from the doors so as to detect passengers moving to enter the rail car. When orienting the sensor, it is important to ensure that microwave energy will not be reflected from a highly reflective surface, such as metal. Such a situation was experienced during the demonstration on Baltimore's MTA and resulted in false detections.

To ensure that the door sweep is clear requires observation of a plane coincident with or parallel to the door sweep. Photoelectric presence sensors employ beams of light with very small beam widths, making them ideal to define a plane for observation purposes. Complete definition of an observation requires an array of photoelectric presence sensors. The elevator industry uses this approach to ensure that doors are clear before closing. A series of infrared light beams look across the door opening as the doors are closing; if any beam is blocked, the doors will open.

Figures 23 and 24 illustrate two possible arrangements for the system. In both arrangements, infrared transmitters generate beams scanned by receivers on the opposite side. In Figure 23, the light beams are separated vertically by 1.8 in., which will provide detection of all but the smallest objects. In Figure 24, the beam separation distance is smaller still, which allows detection of even smaller objects.

## RECOMMENDATIONS FOR FUTURE RESEARCH

On the basis of their experiences, the researchers have identified project-related areas that warrant further research or actions. These areas include incident information collection, sensor-based observation aid development, and platform safety in the broader sense. The following paragraphs provide the researchers' recommendations in these areas.

### Incident Information Collection

To effectively assess the threat to passenger safety that door observation systems must address, it was necessary to rely on

incident information and statistics provided by transit systems. In attempting to collect this information, it was the researchers' experience that very few transit systems collect incident information in a way that is useful to projects such as this.

Generally, those properties collecting statistics did so in a general way and did not categorize incidents. The best information was obtained during site visits through discussions with operations personnel. This information was the primary means used to develop the assessment of the threat to passenger safety addressed by the recommendations made in this report.

To better assess any threats to passenger safety and develop suitable responses, improved information is needed; therefore, it is recommended that uniform procedures be developed for reporting safety-related incidents. This information collection should be administered through an administrative agency with significant transit industry influence, such as the Federal Transit Administration (FTA) or the National Transportation Safety Board (NTSB). Better information will allow threats to be more fully understood and suitable responses (in the form of safety aids or operating procedures) to be developed.

### **Sensor-Based Observation Aids**

During the earlier discussion of conceptual sensor-based observation aids, guidelines were provided on the types of sensors appropriate for observation aids, how these sensors can be used in a system, and how they can be integrated with other vehicle systems (such as door controls) and communications systems (such as automatic voice announcements). This earlier discussion also summarized the results of laboratory testing of sensors, recommended sensor technologies for observation aids, and discussed system architectures, including integration with vehicle systems.

Although the researchers evaluated the sensors during the demonstration at Baltimore's MTA, this evaluation did not assess how the sensors would work in a larger system. The researchers believe that the recommended sensor technologies are appropriate for the application.

Although the sensor demonstration is extremely significant,

the base of knowledge for these systems must be expanded to allow them to proceed into full-scale development and implementation. For this reason, it is recommended that further research be performed into the use of sensor-based observation aids. Furthermore, it is recommended that this follow-on research address more of the system integration issues, particularly the timing relationships to be employed in the system controller. As part of this research, it is recommended that a demonstration system be developed using a microwave sensor and a photodiode array.

For this follow-on research, a system controller could be developed using off-the-shelf personal computer (PC) technology with a limited amount of developmental software to implement the sensor interrogation timing scheme. Although the target architecture for a production system controller would be simpler and probably based on a microcontroller rather than a PC architecture, the use of a PC for these tests will facilitate software modifications associated with exploration of the timing relationships. This system should then be subjected to operational trials on board different types of rail vehicles.

Data should be logged by the system and correlated with direct visual observations to allow assessments to be made of system performance under varying conditions. Data should be logged for protracted periods (weeks or months) to allow all potential operational scenarios to arise and be assessed.

### **Platform Safety**

As indicated previously, a comprehensive approach to safety requires systematic study of such elements as observation aids working in conjunction with other elements (e.g., passenger education), operational factors (e.g., announcements), facility features (e.g., tactile platform edges), and vehicle features (e.g., sensitive door edges). Although this project addressed observation aids in detail, there is considerable potential for further research into platform safety. For this reason, it is recommended that establishment of an additional project be considered to examine the broader issues associated with station platform safety.

## PART II—Supporting Technical Information

### CHAPTER 1

## EXISTING OBSERVATION APPROACH CASE STUDIES (PROPERTIES VISITED ONLY)

### MIRROR-BASED OBSERVATION AIDS

Of all current observation aids, mirrors have found the widest usage in the transit industry. This is because of their low procurement cost, ease of installation, and low life-cycle maintenance costs. During the site visits, mirrors were seen in use on 11 of the 17 properties visited. In the responses to the transit property questionnaire, an additional five North American light rail systems (i.e., Edmonton, Calgary, Sacramento, PA Transit, and San Francisco Municipal) were identified as users of mirrors as observation aids. Also, the Moscow Metropolitana in Russia and the Metro de Madrid in Spain were identified as users of mirrors through questionnaire responses. The balance of this section discusses mirror use for those properties visited as part of the research program.

In general, those properties employing mirrors made widespread and consistent use of them to enable operators to observe doors. There was little variance in use from system to system, and little that could be classified as unique. Use of mirrors was observed at both heavy and light rail operations with all light rail vehicles observed being equipped with some type of mirrors. For light rail vehicles, mirrors are generally the sole method employed to view the doors. Rarely did an operator of a light rail vehicle directly observe the doors. For heavy rail vehicles, the mirrors are employed where a conductor or train operator must see around a platform curve or an obstruction. The following paragraphs discuss use of mirrors by the transit properties visited by the researchers.

#### Los Angeles County Metropolitan Transportation Authority (LACMTA)

The researchers visited the Blue (light rail) and Red (heavy rail) lines of LACMTA. During this visit, operational procedures, vehicle characteristics, and facility characteristics on both lines were studied. The Blue line has been in service since July 1990 and provides light rail service between Long Beach and downtown Los Angeles. The Red line, opened in March 1993, provides limited heavy rail service in downtown Los Angeles and links with the Blue line at Union station. In the Blue line, mirrors were used as an observation aid; no aids are in use on the Red line. Vehicles operated on the Red line have transverse cabs, the station platforms are completely straight, and operating procedures are similar to those of WMATA in Washington, DC, and MARTA in

Atlanta, Georgia. As a result, there is no need for observation aids on the Red line. The balance of this discussion will address the Blue line's use of mirrors as an observation aid.

There are 19 stations on the Blue line. Eighteen are above ground. The 7th St. Metro Center station in downtown Los Angeles is underground. All platforms have straight edges, and canopies are used at above-ground stations. Portions of the northern end of the line in central Los Angeles and the entire southern end of the line in Long Beach operate on city streets, sharing them with motor vehicles. Blue line trains consist of four cars (two articulated vehicles) with a catenary supported overhead power system. The cabs of the cars are full width, with the motor operator's main control panel on the left side of the car. Blue line trains operate using single-person crews, with this person responsible for all aspects of train operation, including train motion and door control. Automatic train control is not feasible because of interaction of the trains with automobiles and trucks on the street-level portions of the right of way.

The doors of Blue line trains are under the operator's manual control. As the train departs the station, the operator observes the platform and doors by using mirrors located to provide a view of the sides of the rail vehicle. The mirrors are also used during street-level operations to help avoid motor vehicles. The mirrors are on the outside of the train and are visible to the operator through the side window of the cab. Train operators rely completely on the mirrors for door observation. They were not observed to open the cab window and make direct visual observations of the car doors. When the operator has observed that the doors are clear to close, a button is pushed, which causes an audible chime to be heard just before the closing of the doors.

#### Chicago Transit Authority (CTA)

Members of the research team visited the facilities of CTA and studied the operations, vehicle characteristics, and facility layouts on each of the six heavy rail lines that CTA operates. These six lines are as follows:

- Evanston Shuttle (Purple line),
- Howard-Dan Ryan (Red line),
- Lake-Englewood-Jackson Park (Green line),
- O'Hare-Congress-Douglas (Blue line),
- Ravenswood (Brown line), and
- Skokie Swift (Yellow line).

A new line has been opened to provide service between the center of the city and Midway Airport but, at the time of the site visit, this line had yet to open and the researchers could not study its characteristics. This line is designed to operate with single-person crews and features facility characteristics, such as straight platform edges, which support this mode of operation.

There are 142 stations on the existing portions of the CTA system. Most of the observed stations are above ground on elevated platforms, while a smaller number are underground. Generally, platforms are constructed with straight edges; however, some stations on the older parts of the line exhibit severe curvatures. One example of a station with curvature is the Chicago Avenue station on the Ravenswood line. CTA works around this curvature by operating shorter-length trains on this line.

The trains generally consist of four cars, with six to eight cars during rush hours. The cabs of the cars are half-width, with the motor operator's position on the right side of the car. Except for the single-car Skokie Swift train and the new Midway line, which have been or are designed for single-person crews, CTA trains operate with two-person crews. The motor operator, riding in the lead car, controls train movements manually, while the conductor, in the center of the train, operates doors and announces stations.

When the train pulls into a station, the conductor opens the doors from a control panel on the appropriate side of the car. There are two separate controls for operating the doors—one for the doors forward and one for those aft of the conductor's location. After the doors open, the conductor opens the side window and looks out to observe passenger loading. When it appears that all doors are clear, the conductor concentrates on the aft doors and activates the appropriate close door control. This process is repeated for the forward doors. When all doors are closed, the conductor signals the train operator that it is safe for the train to proceed. As the train leaves the platform, the conductor observes the platform until the train is clear of the platform.

Under most circumstances, the conductor does not need observation aids to ensure that the doors are clear before closing. Mirror-based observation aids are used in a few stations, including the southbound side of the Loyola station on the Red line and the eastbound side of the Addison Avenue station on the Blue line. The Loyola station is also equipped with CCTV. Details of this CCTV installation are provided later in this report.

The mirrors are mounted under the platform overhang where they will be visible to the conductor when the train is properly berthed. These mirrors are approximately 4 ft from the edge of the platform and approximately 9 ft above the surface of the platform. For conductors of average height (5 ft 6 in.), the mirrors are approximately 5 ft from the conductor's eyes when the train is berthed. Multiple mirrors are provided along the platforms to allow for variances in the conductor's position with trains of differing lengths. These mirrors are positioned one car length apart. The mirrors have flat faces and are approximately 12 in. in diameter. They are positioned so that the platform edge is centered in the image, thereby allowing the conductor to view equal portions of the rail car and platform.

## **Greater Cleveland Regional Transit Authority (GCRTA)**

GCRTA operates both heavy and light rail systems. The light rail system consists of the Blue and Green lines and the heavy rail system is referred to as the Red line. The cars, platforms, and operations of the two rail systems are completely different; however, the heavy and light rail lines share track and stations at certain locations. In these stations, the platforms for each type of operation are separated because of platform height requirement differences. Of the two operations conducted by GCRTA, only the light rail system employs mirrors as observation aids. All platforms on the heavy rail system have straight edges, making observation aids unnecessary. The balance of this discussion will address the use of mirrors on the Blue and Green lines.

There are 29 stations on the Blue and Green lines. Most of the stations are at ground level with platform canopies. Whether above or below ground, most platforms have straight edges. Some have minor curvature, the extent of which does not impede the train crew's field-of-vision. Generally, the curvature of the platform is convex relative to the plane of the car side; this enhances visibility because the ends of the train are closer to the operator than they would be with a straight platform.

The trains generally consist of one articulated vehicle with two or three articulated vehicles operated during rush hours. The cabs of the vehicles are half-width, with the motor operator's control panel on the left side of the car. Platforms are generally on the right side of the train. The light rail system operates with a one-person crew for each car in the train consist. Each crew member is responsible for operating the three sets of doors (per side) of his or her specific car, as well as fare collection in selected areas. The motor operator, in the lead car, is also responsible for manual control of train movement.

When the train enters the station and comes to a complete stop, the crew members push buttons to open the car doors. After passengers have completed loading, the crew member, after observing the external door area through the use of a mirror mounted on the outside of the cab and by observing internal door areas directly, closes the doors. Two separate controls exist for closing the doors—one control activates the front door and one controls the middle and rear doors.

## **Massachusetts Bay Transportation Authority (MBTA)**

MBTA's four major lines are the Red, Blue, Orange, and Green lines. The Red, Blue, and Orange lines are heavy rail operations; the Green line features articulated light rail vehicle operations. During this visit, emphasis was placed on observing the heavy rail lines.

MBTA is the oldest subway system in America. A capital expenditure program in the late 1970s and early 1980s resulted in expansion of the Red and Orange lines. The result of this

is that the MBTA features a varied mix of facilities, including newer stations with center platforms and older stations with right-side platforms. The platforms are generally straight with minimal obstructions near the platform edge. The exceptions to these conditions are found in the stations nearer to the center of the city and on the Blue line, which has the older portions of the system.

Heavy rail operations generally consist of four- or six-car trains. Blue line trains are generally operated with four cars because of lighter traffic on this line; the more heavily traveled Red and Orange lines have six-car trains. These cars operate in married pairs with a full-width cab at each end of the pair. Cars on the Red and Orange lines have three sets of doors per side while the smaller Blue line cars have two sets of doors on each side.

All MBTA heavy rail trains operate with two-person crews consisting of a motor operator and a conductor. The motor operator controls train motion and station positioning while the conductor ensures safe door operations. The train conductor is usually in the cab of the next-to-last car of the train.

All MBTA vehicles are under full manual motor operator control. The doors on MBTA heavy rail trains are operated by the conductor. Upon arrival in a station, the conductor opens the doors using cab controls. Two sets of controls are provided on either side of the cab for this purpose. These controls operate two door zones—one that consists of the doors in the conductor's car and the doors forward of that location, and one that consists of the doors aft of the conductor's car. Upon completion of car loading and unloading, the conductor looks forward and aft of his or her location, closing the doors in each of the two zones separately. When the doors close, a warning tone is played in the rail cars to notify the passengers. Under normal operations, a train control system interlock prevents the train from moving with the doors opened or unlocked.

MBTA employs various types of mirrors in its operations. These mirrors include the flat and convex types. These mirrors are employed at a few stations and are found predominantly on the Red and Orange lines. These mirrors are on the station platform in a position that makes them usable for the conductor. The mirrors are mounted on platform canopies or other station structures. Generally, they are set back 4 ft from the platform edge and are 8 ft above the platform surface.

### **Toronto Transit Commission (TTC)**

TTC operates three heavy rail lines, a single light rail line, and several bus and street car routes. All operations of TTC were viewed during the site survey; however, observation of the heavy rail lines was emphasized. In general, the light rail system is very short, with a total right-of-way length under 2 km and with vehicle and operational characteristics very similar to Cleveland's GCRTA and Boston's MBTA. TTC's heavy rail lines include Yonge-University-Spadina, Bloor-Danforth, and Scarborough RT lines. Except for the Scarborough line, TTC's heavy rail operations feature relatively modern (1950s) facilities and equipment designs. The Scarborough RT line is early 1980s vintage and features

automatic train operation (ATO) and rail vehicles similar to the SkyTrain system in Vancouver (except that TTC's vehicles have a full cab to accommodate a single crew member). TTC employs mirrors and CCTV in its heavy rail operations. The CCTV is being used on a limited, experimental basis and is restricted to two stations and six rail cars. Details of TTC's use of CCTV are provided later in this report.

TTC's three heavy rail systems consist of 65 stations, including the 6 stations on the Scarborough RT line. These stations all have straight platforms with no obstructions near the edges of the platforms. The only potential influence of TTC facilities on door operation is platform access staircases, which are as close as 8 ft from the edge of the platform. This situation, which exists in only a few stations, presents the potential for a running passenger to attempt to enter the train with little warning to the train guard (conductor).

Trains on the Yonge-University-Spadina and Bloor-Danforth lines operate with a consist of six cars regardless of the time of day. During operational peak times, trains on the Scarborough RT line operate with four cars. During off-peak time and on weekends, the RT trains operate with two cars. Each car has a single half-width cab on the right side. All TTC rail cars exist as married pairs. The rail cars have four sets of doors per side (except for the Scarborough RT cars, which have two sets of doors per side).

Trains of the Yonge-University-Spadina and Bloor-Danforth lines operate with a crew of two (i.e., a motor operator and a guard [conductor]). The persons who fill these roles are cross-trained and switch roles each time a train reaches the end of the line. The trains on these lines are manually controlled. The responsibilities of the motor operator include train motion control and in-station train positioning. The guard is responsible for observing and controlling the train's doors and is in the cab of the next-to-last car of the train. The conductor uses a trainlined buzzer system to notify the motor operator that it is safe for the train to proceed from a station.

The trains on the Scarborough RT line are normally operated in the fully automatic control mode. These trains have only a single crew member whose primary responsibility is control of the train's doors. When the doors have closed, the train moves out of the station without operator intervention. Scarborough RT trains have a manual control mode, which is employed under exception conditions or when work zones exist on the right of way.

As was stated, rail car doors on the Bloor-Danforth and Yonge-University-Spadina lines are under the control of the guard. Door controls are in each cab of the train. Two sets of controls are provided—one set for the doors of the car where the guard is and for the doors in the cars forward of that location and one set for the doors in the cars aft of the guard's location. The guards will stick their heads out of the windows to observe the doors and when the doors are clear, blow a whistle and close the doors aft of their locations. This process is repeated for the doors forward of their locations. When all doors have been closed, the guard uses the buzzer to notify the motor operator that the train can proceed.

As a result of a door-related fatal accident approximately 4 years ago and the subsequent inquest, TTC has implemented

enhanced door observation and control procedures, as well as door observation aids. One of these aids is a flat mirror on the wall at the end of the platform. This mirror enables the motor operator to view the side of the train without sticking his or her head out of the window. In addition, the guard uses this mirror to observe the train as it leaves the station.

A second unique safety aid is a set of three dots placed on the station wall. These dots—red, green, and orange—are used as reference points in positioning the train. The red dot is at the leading (cab) end of the platform and serves as a stop location marker for the motor operator. The second dot (green) is used by the guard to verify that the train is berthed properly. The third dot, used when the train begins to leave the station, marks where the guard may stop observing the platform and pull his or her head back in the cab. The intent of this is to prevent or immediately identify dragging incidents, thereby allowing an emergency response before a serious injury occurs.

### **Metropolitan Transportation Authority—New York City Transit (MTA-NYCT)**

MTA-NYCT is the largest mass transportation rail system in North America and ranks among the five largest in the world. MTA-NYCT has more than 690 miles of track and has rail operations in the boroughs of Manhattan, Brooklyn, Queens, and the Bronx. The system includes 22 lines and more than 460 stations. MTA-NYCT initiated revenue service in 1904 and has expanded to where it operates approximately 6,000 rail vehicles and carries more than 2 million passengers daily. During multiple visits to the MTA-NYCT system, the researchers observed both mirrors and CCTV in use. The balance of this section discusses the application of mirrors to MTA-NYCT's operations. A discussion of the use of CCTV is provided later in this report.

The hundreds of stations in the system represent myriad designs. These range from the oldest stations (in Manhattan) to the newest (in the outer boroughs of the Bronx, Brooklyn, and Queens). The earliest stations in Manhattan were designed to fit within the confines of the urban landscape. As a result, the stations exhibit varying degrees of platform curvature and visual obstructions arising from structures and structural supports. As the system expanded to the outer boroughs, adequate space was available for the stations and platforms to be constructed with straight edges and to be free of obstructions. The number of cars in a train consist can range from 6 to 10. There are various vehicle configurations, including half-width and transverse cabs. Where the cab is half-width, it is on the right side of the car relative to the direction of travel.

The MTA-NYCT system operates with two crew members per train, the motor operator and the conductor. The motor operator is responsible for train movement, positioning the train in the station, and serving as the communication interface with central operations. All train movement on MTA-NYCT is under full manual control. The conductor operates the doors and announces stations. The conductor is positioned at the middle of the train consist to minimize observation distances to the front and rear of the train.

The conductor operates the doors of the MTA-NYCT cars.

When the train pulls into the station, the conductor opens the doors from a control panel on the appropriate side of the car. There are two separate controls for the operation of the doors—those forward of the conductor and those aft of the conductor. After the doors have been opened, the conductor opens the side window to observe passenger loading. The conductor waits at least 10 secs for passenger loading. After a preliminary observation has been made that the doors are clear, the conductor announces the closing of the doors using the train PA system. When all passengers are clear, the conductor will close the doors in the rear cars. When the locked door signal is received, the conductor will then close the forward section of car doors. When the doors are all closed, the conductor will remove the door key, which will alert the motor operator that it is safe to proceed. As the train departs the station, the conductor observes the doors until the train has traveled three car lengths or has left the station. Observation during station departure consists of viewing the forward and aft cars at least twice to ensure that no passenger or item is trapped between the doors.

Where platform curvatures exist, they include convex and concave curvature relative to the plane of the rail car side. While some curvatures are slight, others are severe and result in some portions of the train being obscured from the conductor's view. Other stations were observed where the platform edge is an S configuration that limits the conductor's view along the concave portion. Approximately 27 percent of the platforms in the MTA-NYCT stations have some curvature.

The configuration of many of the stations and platforms in the MTA-NYCT system necessitates the use of aids to assist the conductor in observing passenger loading. The type and number of aids used depends on the configuration and severity of the curvature of the platform and the extent of obstruction of the field-of-view from physical structures, such as columns.

Stations with unobstructed platforms and a relatively small concave curvature generally use one or two mirrors to assist the conductor in observing the doors. These mirrors are mounted on a nearby structural component (i.e., ceiling, wall, or column) approximately 7 ft above platform elevation. They may be flat or convex, depending on the field-of-view required. Most of the mirrors used are circular and convex.

### **Port Authority Trans-Hudson (PATH)**

PATH operates four heavy rail lines that serve 13 stations. These four lines are the Hoboken-33rd Street, Newark-World Trade Center, Hoboken-World Trade Center, and Journal Square-33rd Street line. PATH is fairly unusual among mass transit systems—it provides interstate service and shares this distinction with only PATCO (New Jersey-Pennsylvania) and WMATA (Maryland-Virginia-DC). PATH lines connect midtown and lower Manhattan in New York City with communities such as Jersey City and Newark in New Jersey.

Most of the 13 PATH stations are underground and have platforms with straight edges. Exceptions are the Journal Square station in Jersey City and the Newark Pennsylvania station; these are at or above grade level but enclosed by station

structures. For older stations, such as those in lower Manhattan, structural columns are as little as 2 ft from the edge of the platform. This restricts the conductor's ability to observe an area in front of the doors before closure. The number of cars in a train consist can range from six to eight. Each rail car has a single, half-width cab, which is on the right side. Each rail car has three sets of double sliding doors per side.

Each PATH train operates with a two-person crew consisting of a motor operator and a conductor. The motor operator is responsible for manually controlling train movement while the conductor is responsible for operating and observing the door and making public address announcements. The conductor is positioned at the rear end of the lead car rather than in the middle of the train, as is the case with most two-person operations.

As was stated, the conductor controls the doors of PATH trains. When the train pulls into the station, the conductor opens the doors from a control panel on the appropriate side of the car. There are two separate controls for operating the doors—one set operates those in the conductor's car and one set operates those aft of the conductor. As the doors open, the conductor opens the side window to observe passenger loading. After a preliminary observation has been made that the doors are clear, the conductor announces the closing of the doors using the train's public address system. When the doors are observed to be clear, the conductor closes the doors in the forward car. When the locked door signal is received, the conductor closes the rear car doors. When all doors are closed, the conductor removes the door key, which alerts the operator that it is safe to proceed. The conductor continues to observe the doors until the train has left the station.

Only one station in the PATH system, Journal Square, requires the use of an aid for observing the doors. Because of the S configuration of the westbound platform, the rear cars of the train are difficult to observe. This difficulty is heightened by station structures. To assist the conductor, two convex mirrors have been installed to aid in observing the rear cars. One mirror assists the conductor when the train is berthed with eight cars; the second mirror is positioned to assist with train consists of seven cars. These mirrors are mounted on station structures approximately 6 ft from the edge of the platform and at a height of approximately 7 ft.

### **Washington Metropolitan Area Transit Authority (WMATA)**

WMATA's Metro, initially opened in 1976, operates five lines within the District of Columbia and the surrounding suburbs in the states of Maryland and Virginia. The Metro system includes 70 stations; additional stations are under construction in suburban areas. Approximately 40 stations are underground.

Most station platforms are configured in a straight line with a combination of center island and right-side platforms. Subway station platforms feature high overhead ceiling clearance along the edge of the platform; however, certain facility structures and overhead walkways limit this clearance in selected areas. Lighting in the underground stations is dim compared with other systems and is provided indirectly from

fluorescent lights along the lower portion of the outer walls of the stations.

Above-ground platforms generally have canopies, although not along the entire length of the platform. To assist in passenger safety when trains are approaching or departing the station, 6-in.-diameter lights are spaced approximately every 4 ft along the outer edge of the platform. These lights are continuously lit, although at relatively low levels of illumination.

When a train approaches the station, the intensity of the lights alternates approximately every sec between the passive low-level illumination and a brighter level of illumination. This feature makes WMATA unique because it is the only system in North America that warns passengers that a train is approaching.

WMATA operates trains of varying length—four- and six-car trains run during off-peak hours; eight-car trains operate during rush hours and are often loaded to capacity with standees. All cars have full-width cabs with main operator controls on the right side. WMATA operates all trains with single-person crews. The trains are normally operated under automatic control, although manual overrides are possible. The operator ensures that the doors are clear before activating the door-close button. Following the closing of the doors, the train operator depresses an automatic train operation (ATO) Resume pushbutton to initiate train movement.

Door opening is normally part of automatic operation of the train when the train is berthed in a station. The operator opens the appropriate side window and directly views passenger egress along the edge of the platform. Once the operator has determined that the doors are clear after passenger boarding, the operator activates the door-close button. Immediately, a two-chime sound is heard, which is followed by closing of the doors. The operator can activate the audible chime and prevent the doors from closing by immediately pressing the door-open button after the door-close button was pushed. This is often done under heavy loading conditions such as rush hours to provide advance warning of door closings.

WMATA car doors do not contain any sensitive edges or sensors and, therefore, will not recycle once an obstruction is encountered. The door mechanisms will maintain the low-level closing pressure on the obstruction until it is clear, but will not allow the doors to be pushed open. This low-level pressure prevents serious injury to any passenger who may become trapped between the doors. Allowing the passenger to clear the obstruction may require the operator to cycle the doors. The research team observed one passenger who became trapped between the doors after having run to enter the train as the doors were closing. The passenger could not clear himself and the train operator had to recycle the doors. The research team's opinion of this incident is that the passenger failed to exercise due caution and took an unnecessary risk when attempting to board the train.

Most WMATA stations have straight platform edges and do not use aids to assist operators in observing passenger loading and unloading. Exceptions to this are the southbound side of the Silver Spring and Brookland stations on the Red line, which had two and three mirrors respectively. The small range of



movement afforded the train operator by the relatively small cab window opening, combined with the concave curvature of the platforms in these two locations necessitated the installation of the aids. The 2-ft-diameter convex mirrors at the Silver Spring station are approximately 6 ft from the edge of the platform at an elevation of 5.5 ft and are aligned with the four-car and six-car position markers. These mirrors are not used by all operators—the research team observed a four-car train that berthed between the mirrors, making them unusable.

The Brookland station features a platform that is half covered by a canopy and half open. Two of the three mirrors at the Brookland station are mounted on the edge of the passenger waiting structures aligned with the four- and six-car markers. The third mirror, for eight-car trains, is at the extreme southern end of the platform. All three of the 2-ft-diameter convex mirrors are approximately 10 ft from the edge of the platform (see Figure 40). The distance from the edge of the platform and the distorted image obtained from the convex mirrors limit the operator's ability to observe the car doors, especially at the rear of eight-car trains. These mirrors provide a view of the rear portions of the train, which are out of the train operator's direct line of sight. Because the rear of the train is under the platform canopy, it is in shade, unlike the front of the train.

Figures 41 and 42, photos taken at a time of peak sunlight at WMATA's Silver Spring station, illustrate the difference in contrast. In daylight, the difference in contrast between the front and rear of the train may make viewing the rear difficult. A similar problem may exist at night because of light reflected from the platform canopy back to the platform surface; however, the researchers did not verify this.

### Maryland Mass Transit Administration (MTA)

The Maryland MTA operates in the greater Baltimore area and consists of light and heavy rail systems. Both transit systems are relatively new, with the heavy rail operation opening in 1983 and the light rail system initiating operations in 1992. The heavy rail system includes 12 stations and operates more than 22 km of trackage. An additional two stations are under construction. The light rail system operates more than 25 km of rail, with additional stations proposed, including one to service Baltimore-Washington International Airport. All of the heavy rail system stations have straight platform edges and no observation aids are employed. The heavy rail vehicles are identical to those used on Metro-Dade Transit in Miami. MTA's operating procedures are the same as Metro-Dade's. MTA's light rail system employs mirrors on both the vehicles and platforms. The balance of this section will address the light rail system's use of mirrors.

All light rail stations are at ground level and feature straight platform edges. Station designs include both center-island and right-side platforms. Forty percent of the line is single rail with dual-track operation used on the central portion of the line; both the northern and southern ends are single track.

Because the light rail vehicles have high floors, passengers must ascend steps to board the trains. Figure 43 illustrates the configuration of the MTA's light rail vehicles. To aid mobility-impaired persons in boarding the trains, each station contains an inclined ramp leading to a floor-level platform. The first door of the rail vehicle is berthed in line with this platform and a ramp within the car is extended to the station platform

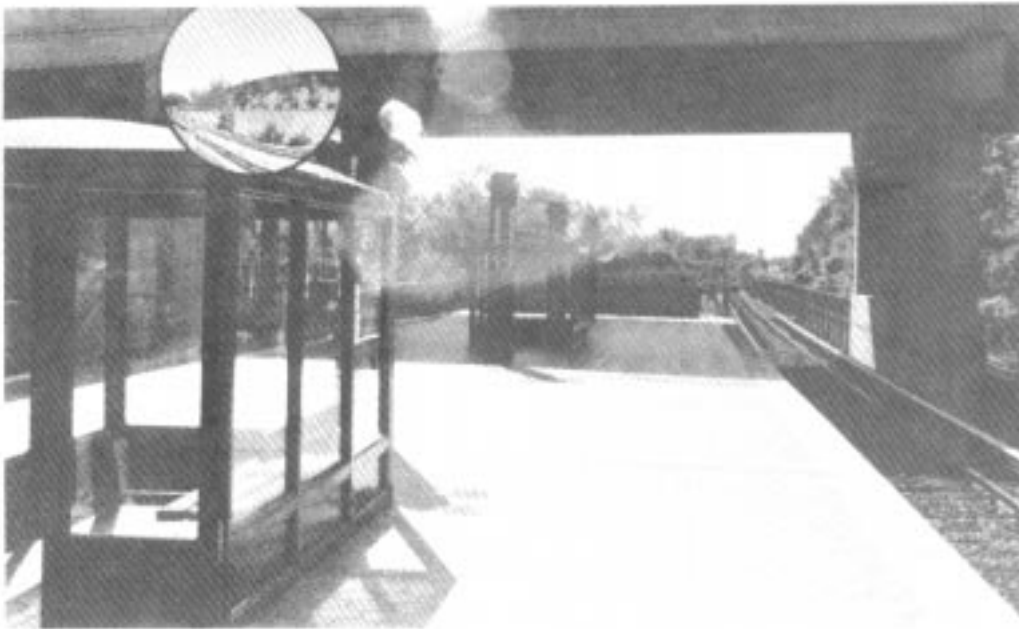

Figure 40. WMATA mirror installation.

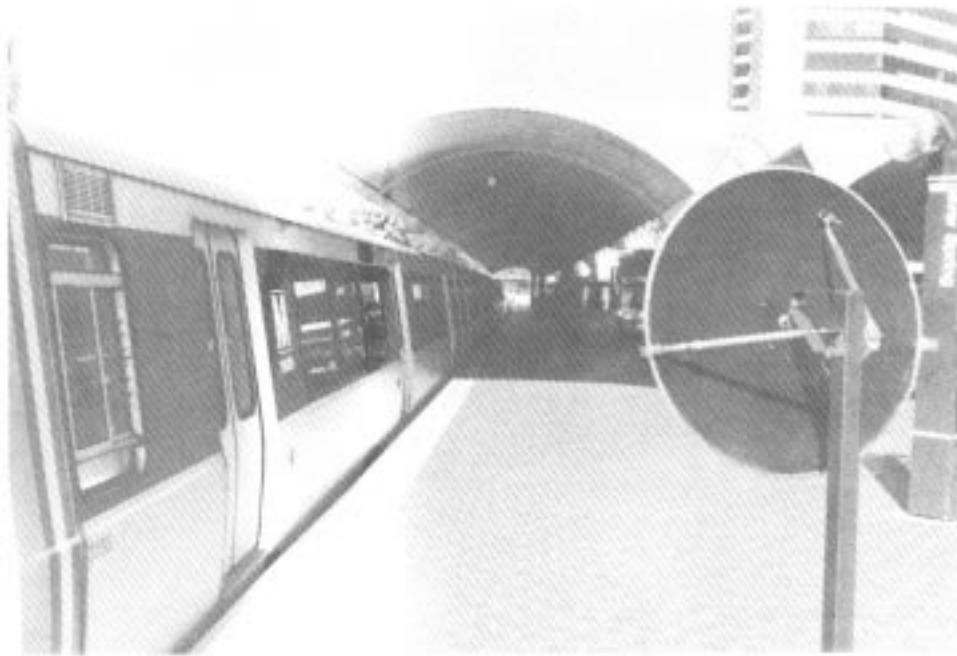

Figure 41. WMATA Silver Spring station contrast differences (1 of 2).

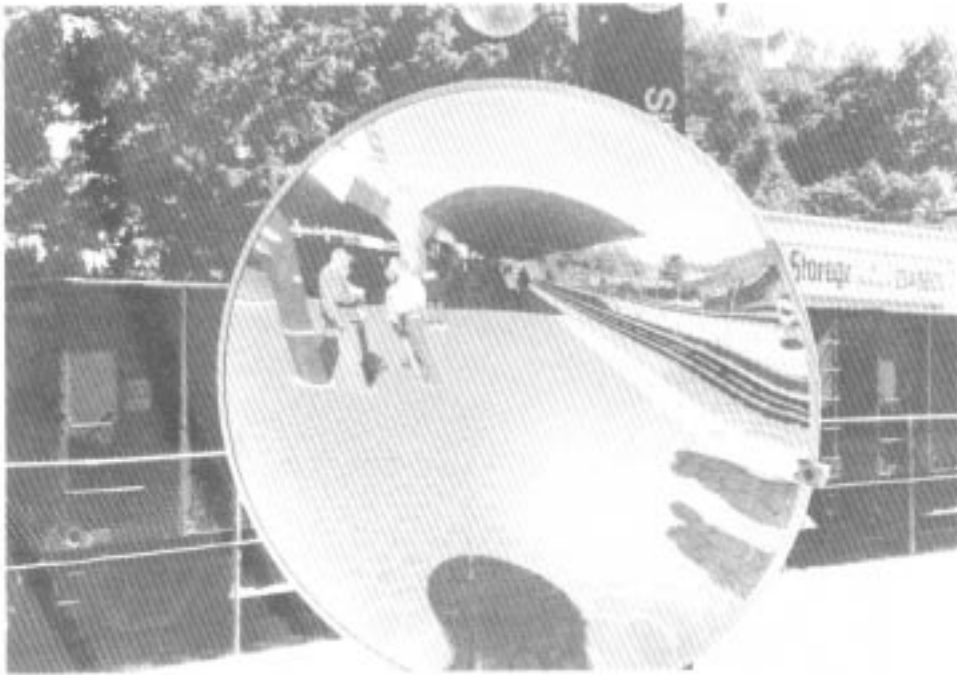

Figure 42. WMATA Silver Spring station contrast differences (2 of 2).

to bridge the gap between the platform and the vehicle. The train operator manually extends and retracts this ramp during boarding. Trains consist of center-articulated vehicles with an overall length of 95 ft. Trains up to three vehicles long (285 ft total) were observed operating during rush hours. All vehicles have full-width cabs at each end with controls slightly to the left

of the vehicle's central axis. Baltimore's light rail vehicles operate with a single-person crew, regardless of train length, and feature manual controls.

After the operator has brought the train to a complete stop at a station, the operator activates the door-release button. Passengers then press yellow pushbuttons next to all doors, inside



Figure 43. Baltimore MTA light rail vehicle side configuration.

and outside of the car. These buttons only open the doors adjacent to the controls. The operator can also open all doors, if conditions so warrant, by pressing the door-open pushbutton. After passenger loading and unloading is completed and the operator has determined that the doors are clear, the door-close control is activated.

The operator observes passenger loading and unloading through the use of two sets of mirrors. One set of mirrors is mounted on the exterior of the vehicle at the corners of the cab as shown in Figure 43. These mirrors have flat glass and are aligned to sight along the plane of the vehicle side. The car-mounted mirrors have an angle of incidence of approximately  $5^\circ$  relative to the side of the rail car. In addition, a small convex mirror is mounted below the flat mirror on the same bracket. A third mirror is mounted on a stanchion on the platform or on the ramp servicing handicapped persons. An example of the former mounting location is illustrated in Figure 43 while the latter is shown in Figure 44. This 2-ft-diameter, convex mirror provides a much wider field-of-view to the train operator than the cab mirrors alone and greatly enhances the train operator's ability to view the doors on trains of all lengths. Additionally, this mirror helps the operator to see around light stanchions, trees, and other curbside structures in the downtown areas of the system. This application of a mirror, unique to Baltimore among the light rail systems observed under this project, provides significant benefits.



Figure 44. Baltimore MTA station mirror mounting.

### Port Authority Transit Corporation of Pennsylvania and New Jersey (PATCO)

PATCO operates a single heavy rail line that connects the city of Philadelphia with its western suburbs in southern New Jersey. The system has 23 km of track. Within Philadelphia, PATCO operates as a subway; in New Jersey, it generally operates as an elevated line. In some locations in New Jersey,

this track is adjacent to NJ Transit and Conrail right of way. The general design of the stations features an island platform. This applies to both the underground and surface/elevated stations. Platforms are generally straight; those that are an exception have a convex curvature that tends to enhance the ability

of the train crew to observe the doors. PATCO has implemented side-door observation aids, including CCTV and mirrors. The balance of this section addresses PATCO's use of mirrors; their CCTV application is discussed later in this report.

PATCO operates 125 rail cars, which have half-width cabs with the train operator on the left side of the car relative to the direction of travel. A unique aspect of the cab design is that it is not completely enclosed, thereby providing ready passenger access to the train operator. This cab arrangement is similar to that seen in buses. Although the intent of this is to help to reinforce passenger perceptions of safety, it also enhances passenger service because the train operators can readily interface with customers to provide directions or other information. PATCO stations and operations are designed so that the platform is left of the direction of train travel. As a result, the train operator's location is always adjacent to the platform and direct observations of the doors and platform can be made. The sole exception to this is the Woodcrest station in New Jersey, which has a track serviced by two platforms—it is a point of origination for train runs.

Train lengths vary during the day. During peak periods, trains up to six cars long are operated, while off-peak trains can be as short as two cars long. The system can operate trains up to eight cars long, but current ridership levels have not required their use. The PATCO system is designed for ATO. To ensure continued proficiency in manual train operation, operators are required to operate one run per day under full manual control. Because most operations are performed under ATO, the trains employ single-person crews. This crew size is maintained regardless of train length and during periods of manual train operation with no impact on schedule adherence or safety.

When the train arrives in the station, the operator opens the cab window and opens the car doors while making visual observations. Upon completion of unloading and loading, the operator closes the doors while continuing to make visual observations. The door closing sequence begins with the ringing of a warning bell followed by the physical door closing approximately 2 secs later.

PATCO uses mirrors in its Woodcrest station in New Jersey. This station has a unique platform configuration—it is designed for three-track operation. This is because selected trains originate at this station rather than the eastern line terminus at Lindenwold. All trains originating or terminating at Woodcrest employ the center track, which is serviced by both platforms. As a result, it is possible to open doors on both sides of the train simultaneously in this station. A similar operational situation exists at the Five Points station on the MARTA system in Atlanta. Under this condition, it is not possible for a train operator to make a direct observation of the platform on the side of the train opposite his or her position. The mirrors are positioned ahead of the vehicle to allow the operator to observe the doors on the opposite side of the train from his or her seated position.

As shown in Figure 45, these mirrors have flat glass and are rectangular, rather than round as at most other transit properties. One of the two mirrors is oriented to image the forward portion of the train; the second mirror is used to view



Figure 45. PATCO mirror installation.

the rear of the train. This use of dual mirrors with varied orientations helps to avoid geometric distortion of the images that would have occurred if a single mirror were used.

### Tri-County Metropolitan Transportation District of Oregon (TRI-MET)

In addition to extensive bus service, TRI-MET operates the Metropolitan Area Express (MAX), a light rail system. MAX operates between the cities of Portland and Gresham and has been in service since September of 1986. The MAX system is 15 miles long and has 30 stations. The average weekday ridership on the MAX system is approximately 24,000 passengers. The system operates 26 high-floor vehicles, which were produced by Bombardier. Each of these vehicles is approximately 70 ft long and articulated. The vehicles have full-width cabs at both ends of the vehicle.

Of the 30 stations on the system, 8 are unidirectional (i.e., single-track operation). These stations are in downtown Portland where trains travel into the city on Morrison Street and leave the city on Yamhill Street. The stations are similar to those found on Baltimore's light rail system and have low platforms designed to berth trains consisting of no more than two articulated vehicles. Rather than the ramp and platform

used by the MTA in Baltimore, TRI-MET employs mechanical lifts to raise mobility-impaired persons to the level of the vehicle's floor. New vehicles being built for MAX will feature low floors to ease boarding for mobility-impaired persons.

Like the Blue line in Los Angeles, MAX has door controls that can be used under full train operator control or combined operator and passenger-demand control. The cab door control pushbuttons can either release control of the doors to the passengers (demand mode) or can open all doors along either side of the vehicle. In the demand mode, passengers wishing to board or exit the train must push a button to open the doors. All doors are closed using a single control button under train operator control. In general, the demand controls are used during cold weather to prevent heat from escaping the vehicle through doors that open unnecessarily. The research team sees benefit to using the demand controls at all times because they will cause fewer doors to be open during a given stop under nominal loading conditions. With fewer doors in use, safety is enhanced because there is less likelihood of a passenger attempting to enter through doors that are closing and because having fewer doors in use makes observation easier.

For side-door observation, each side of the vehicle has mirrors. These mirrors provide a fairly narrow field-of-vision along the side of the cars. No additional aids, such as station-mounted mirrors, are provided. In the research team's view, having vehicle-mounted mirrors in addition to platform-mounted mirrors is more effective because the platform- and vehicle-mounted mirrors provide complementary narrow and wide fields-of-vision. The vehicle-mounted mirrors provide a view along the side of the car. Although this view is useful for door observation, there is some distortion of the end of the train opposite the observer's position in the cab because of the convergence of the lines of the platform and car sides. The distortion is not a problem when passenger loading is light but could be during peak loading periods. Platform-mounted mirrors set back from the vehicle and having a wider field-of-vision provide a broader view of the doors, which helps to offset this distortion.

## CCTV-BASED OBSERVATION AIDS

CCTV-based observation aids are used on North American transit properties, but their use is relatively restricted. In European and Far East transit systems, CCTV has realized much broader acceptance. During the site visits, CCTV-based observation aids were seen in use on 4 of the 17 properties visited. These four were CTA, MTA-NYCT, PATCO, and TTC. Excluding MTA-NYCT, the use of CCTV-based observation aids was very limited. SEPTA, in Philadelphia, has indicated that CCTV will be employed on the new rail cars being purchased for the Market-Frankford line. These new vehicles will be designed for single-person operation rather than the current two-person crews, and cab-mounted video monitors will be used to allow the train operator to verify that the train doors are clear before closing. This is a groundbreaking plan because it is the first use of CCTV as the primary means of door observation in North America.

In addition to the five North American users, Teito Rapid



Figure 46. CTA Loyola station curvature.

Transit (Tokyo), the Transportation Bureau of Tokyo Metropolitan Government, Moscow Metropolitana, Metro de Madrid, and Hong Kong's Mass Transit Railway Corporation were identified as users of CCTV from the questionnaire responses. The following paragraphs discuss the usage and system architecture for each of the four North American transit systems using CCTV-based observation aids. In addition, an overview is provided of SEPTA's plans for using CCTV.

## Chicago Transit Authority (CTA)

CTA uses CCTV as a door observation aid at the Loyola station on the Howard-Dan Ryan line. This station, on the north side of Chicago, is elevated. In this station, the system is on the southbound side of the platform. CTA uses two-person crews with the mid-train-situated conductor responsible for door observation and control. Having the person responsible for door observation at the midpoint of the train is beneficial because this limits the required viewing distance to half the train length or, for CTA, less than 200 ft.

CTA uses a CCTV system in the Loyola station so that the train conductor can see the rear two cars of the train, which would otherwise be obscured by the concave curvature of the platform. Figure 46 illustrates the curvature of the platform in the Loyola station. No observation aid is used on the northbound side of the platform because the curvature of this platform relative to the direction of train motion is convex. As a



Figure 47. CTA CCTV monitor positioning.

result, the ends of the train curve toward the conductor, thereby facilitating observation, especially because no station structures block the view.

All of the equipment used in the CTA CCTV observation aid is platform-mounted. This simple system consists of a camera with a direct video feed to a monitor that appeared to have a 15-in.-diagonal screen. On the basis of viewing the monitor image, the camera appeared to provide a field-of-vision on the order of 45°. The camera was positioned to look back at the last two cars at an angle of approximately 20° to a line tangential to the center point of the gap between the cars. The image displayed on the monitor is a full-screen view of the last two cars. The monitor is mounted under the platform canopy approximately 6 ft from the conductor's position when a train is properly berthed. Figure 47 illustrates the location of the monitor relative to the conductor's position. The monitor and the camera are installed in protective housings to protect them from the environment and vandalism.

### Metropolitan Transportation Authority—New York City Transit (MTA-NYCT)

MTA-NYCT makes the most extensive use of CCTV of all the systems visited by the researchers. Included among the stations where CCTV-based aids have been installed are the 42nd Street Shuttle, Grand Central Terminal, South Ferry, and

the 59th Street station, which rank among the busiest locations in the MTA-NYCT system. In all cases, the systems observed were in subway stations. MTA-NYCT plans to install these systems in additional stations.

Each MTA-NYCT train operates under manual control and has a two-person crew consisting of a motor operator and a conductor. Responsibility for door observation on MTA-NYCT trains lies with the conductor, who is in a cab near the middle of the train. As with CTA, this reduces the maximum required viewing distance to approximately 300 ft. The research team observed that these systems have experienced a high degree of acceptance within MTA-NYCT. This is evidenced by the degree to which they are employed by the train conductors. In addition to using the video images, each MTA-NYCT train conductor uses direct observation for the cars closest to his or her position in the train.

MTA-NYCT's CCTV observation aids enable the train's conductor to see the end cars of a train in a station with a concave curved platform or where columns or other structures obscure portions of the platform (e.g., the 42nd Street Shuttle station).

Figure 48 illustrates the degree of curvature at the South Ferry station where CCTV is employed. In most cases, these aids are not designed to be used as the sole means of observation but to provide a view of those cars out of the direct line of sight of the train conductor. For the cars near the conductor's center train location, the conductors rely on direct visual observation of the doors. Generally, the curvature of these platforms is such that the observation aid is only needed for trains of more than four cars. When train lengths increase beyond four cars, the end cars generally go out of sight of the conductor in the center of the train.

All of the equipment used in the MTA-NYCT CCTV systems is platform-mounted. Generally, these systems include multiple cameras, video processing equipment, and display monitors that appeared to have 13-in.-diagonal screens. There are several variations in these systems with the most significant being the use of full-screen or split-screen images. Generally, installations have at least two cameras per platform, and a side-by-side split-screen technique is used to display both images simultaneously. In larger stations, such as 59th Street, up to four cameras are used with two monitors provided at the conductor's location. In a few locations, three cameras are used. For these cases, two monitors are used with one having a split-screen image and the other having a full-screen image. Figure 49 is a block diagram showing the general architecture of the split-screen CCTV aids being used by MTA-NYCT. All video signal interconnections are provided using shielded coaxial cable (RG-59/U characteristics as a minimum). In some cases, these cables were installed in metallic conduit; in other cases, they were not.

Where four cameras are used, dual split-screens are employed and the equipment complement of Figure 49 is doubled. Where three cameras are used, the split-screen system in Figure 49 is used in conjunction with a single camera system identical to that used by CTA at the Loyola station described above. Like

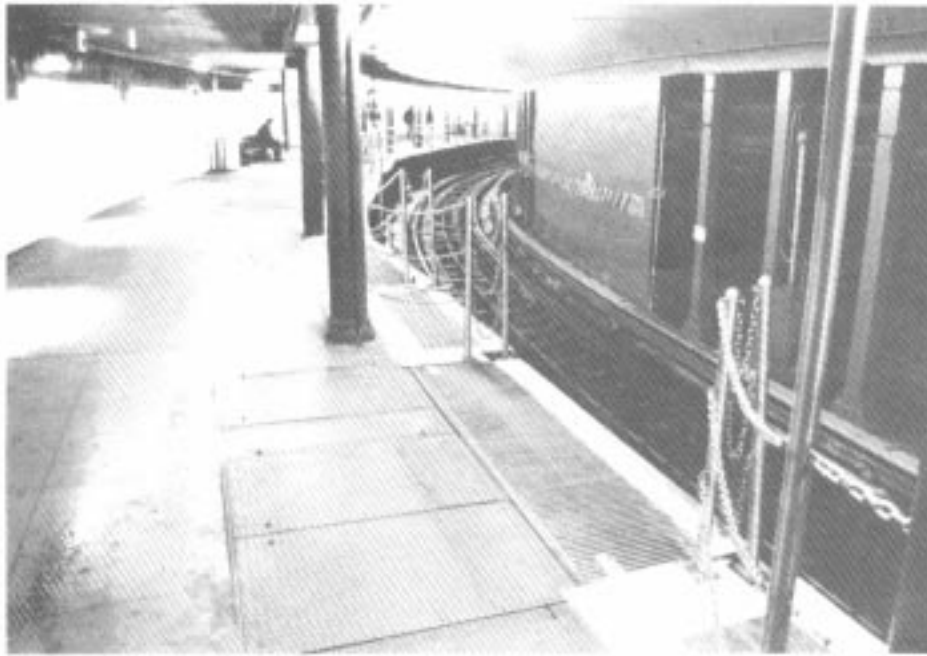

Figure 48. South Ferry station curvature.

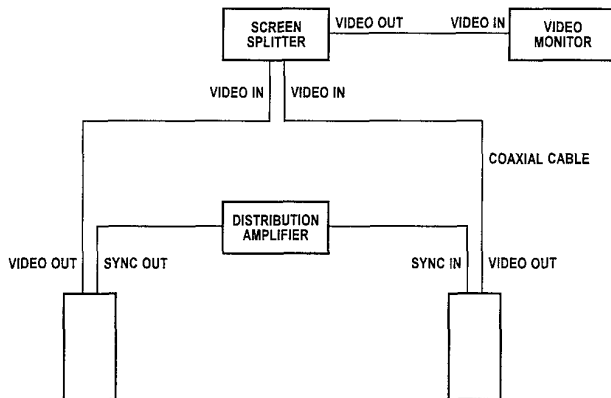

Figure 49. MTA-NYCT split-screen CCTV block diagram.

the CTA system, the cameras used by MTA-NYCT provide a field-of-vision of approximately 45°. All platform equipment is mounted in enclosures to provide protection from environmental factors (e.g., metallic brake dust and moisture) and resistance to vandalism. Figure 50 shows an example of a camera's protective enclosure. Figure 51 illustrates the equipment placements and camera angles relative to platform structures and train stop location markers for MTA-NYCT's Union Turnpike station installation. MTA-NYCT's general approach is to provide images of segments of the train to the conductor in sequential order.

As described above for the CTA CCTV installation, MTA-NYCT's monitors are installed next to the conductor's position



Figure 50. MTA-NYCT camera protective enclosure.

when in a properly berthed train. Generally, these monitors are mounted overhead with the screen approximately 5 ft from the conductor's window opening. Figure 52 shows the installation of the monitors at the Union Turnpike station. Notable at this location is that the face of the monitor has labels indicating what the images are showing in terms of vehicle location in

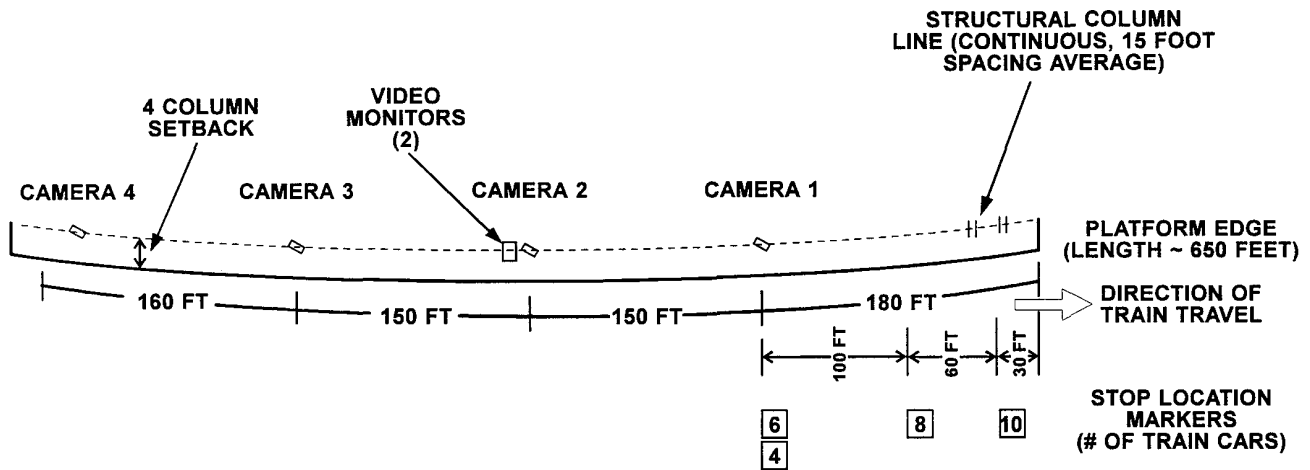

Figure 51. MTA-NYCT Union Turnpike station equipment installation.



Figure 52. Union Turnpike station monitor installation.

the train. Two sets of such labels are provided to account for differing equipment types. These monitors are installed at a height of approximately 8 ft, with the monitor screen angled down to facilitate viewing. At a few locations, multiple

monitors, displaying the same images, have been installed to support variable-length train operations.

### Port Authority Transit Corporation of Pennsylvania and New Jersey (PATCO)

PATCO's use of CCTV is limited to a single system installed in the Haddonfield station. PATCO installed this system, on an experimental basis, to evaluate the effectiveness of CCTV. In this station, two separate systems are installed, with one each on both the eastbound and westbound sides of the platform. PATCO employs single-person operation and automatic train controls with the train operator responsible for door observation. Under selected circumstances (e.g., work zones), the train operator assumes manual train control. The trains employ single-person crews, and door observations are made from the head end of the train rather than the middle as on CTA and MTA-NYCT.

Because PATCO operates trains up to six cars long with a car length of 68 ft, the total distance the train operator is required to view is approximately 400 ft (i.e., cab to last set of doors). PATCO's philosophy relative to the CCTV installation is that it will be the sole means of performing door observation in the Haddonfield station for trains six cars long. As a result, train operators rely solely on the monitor images and do not make direct visual observations of the train in this station.

PATCO employs the observation aid to allow the train operator to see portions of the train obscured because of platform curvature and to enhance the train operator's vision.

Figures 53 and 54 show, respectively, the curvature of the platforms on the eastbound and westbound sides of the Haddonfield station. The cylindrical object at the center top of Figure 53 is one of the camera enclosures. Because of the position of the monitors, this system is only usable for trains that are six cars long. On the basis of observations made during the visit to PATCO, door observation for two-car trains can





Figure 53. PATCO Haddonfield station curvature (eastbound).



Figure 54. PATCO Haddonfield station curvature (westbound).

be performed by direct visual observation because the platform curvature radius does not significantly affect viewing trains of this length.

The CCTV installation at the Haddonfield station uses two cameras arranged to have fields-of-vision that cross as shown in Figure 55. The basic factor that determined the camera locations was the structure at the center of the platform. This structure encloses the stairways leading to the surface and is approximately 6 ft from the platform edge.

The researchers observed that the cameras used by PATCO provided a narrower field-of-vision (approximately  $35^\circ$ ) than the cameras used by CTA and MTA-NYCT. This narrower field-of-vision would indicate that the cameras are equipped with longer focal length lenses. These lenses provide a telephoto effect, which eliminates some of the overlap of the images of the two cameras and makes distant objects appear closer to the camera.

The video from the cameras is merged into a split-screen image and presented to the train operator on a single monitor. These monitors were larger than those used by CTA and MTA-NYCT, with an approximate diagonal screen size of 17 in. These monitors were also farther from the train crew

than those at CTA and MTA-NYCT.

The architecture of PATCO's CCTV installation is equivalent to that for the MTA-NYCT split-screen system. PATCO's presentation of the video image on the monitor was good. As the camera fields-of-vision cross, they appear on the monitor to be mirror images of each other, as shown in Figure 56. The resulting flow of the lines in the image provided by the platform edge and warning stripe tended to draw the research team's viewing of the image from top of the screen to the bottom rather than the normal left to right. As a result, the length of the platform is scanned completely.

The monitors are mounted on the platform at the extreme ends corresponding to the direction of travel as shown in Figure 55. This installation is unique to CTA and MTA-NYCT because the monitor is mounted where protection and shade are not provided by a structure or platform canopy. As a result, PATCO employs a weather-proof enclosure mounted on a free-standing stanchion with a large sun shade around the face of the monitor. In addition, the monitor is angled downward (approximately  $25^\circ$ ) to position the screen for better train opera-

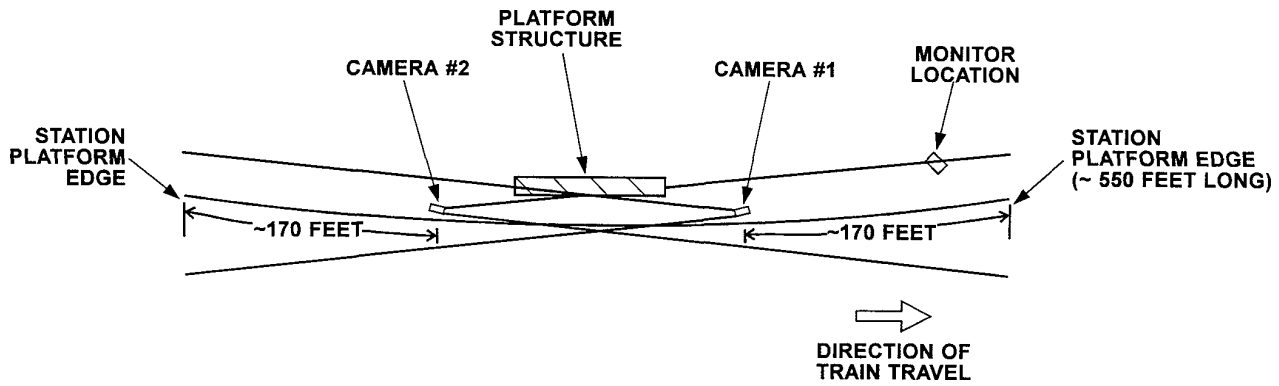

Figure 55. PATCO Haddonfield station camera field-of-vision.

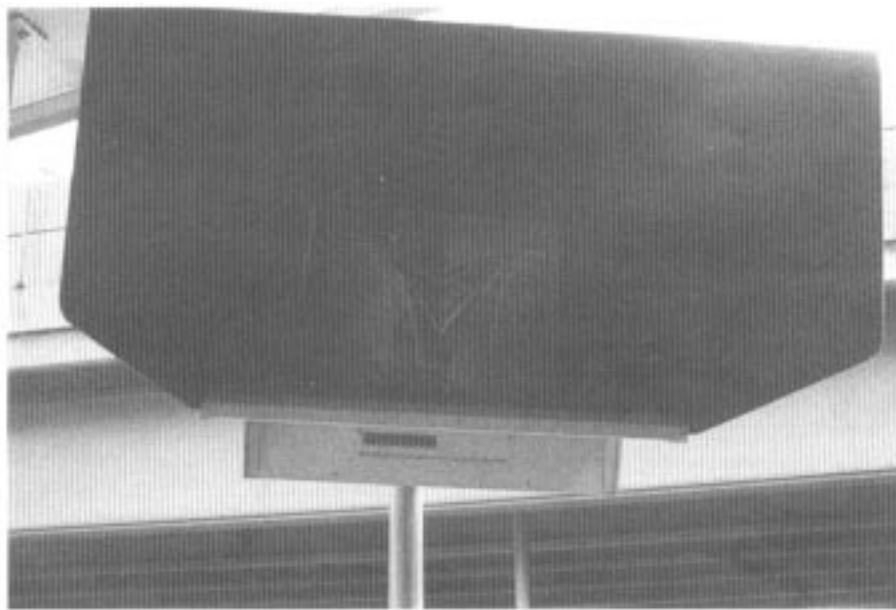

Figure 56. PATCO Haddonfield station monitor display.

tor viewing. Figure 57 illustrates the monitor enclosure and angle of inclination. PATCO has indicated that they experience glare at various times during the day. This glare is the effect of low sun angles and reflections of sunlight off the smooth concrete walls adjacent to the station. PATCO plans to experiment with polarizers on both the cameras and video monitors to attempt to rectify this problem.

### Toronto Transit Commission (TTC)

Toronto's TTC is using CCTV on an experimental basis with equipment installed in six rail cars and at two stations on the Yonge-University-Spadina line. As a result, the CCTV system experiences little use in daily operations. It was indicated by TTC, however, that, whenever possible, the train crews do employ the equipment and have found it highly beneficial. The two locations where equipment has been

installed are the Eglinton and Davisville stations on the Yonge segment of the line. Both of these stations are below grade with respect to the surrounding area and are open to the surface. Figure 58 shows the structural characteristics of the Davisville station, which is essentially the same as Eglinton.

TTC employs two-person crews on the Yonge-University-Spadina and Bloor-Danforth subway lines and single-person crews on the Scarborough RT line. The two subway lines have manual train controls while the Scarborough RT has automatic controls. The crew on the two subway lines consists of a motor operator and a guard. The guard is equivalent to the conductor on CTA and MTA-NYCT systems. The train operator on the Scarborough RT serves the same role as the train operator on PATCO. Under normal conditions, this person is responsible only for door operation but can take manual control of the train when in the Cab Signaling and Emergency modes of operation.



Figure 57. PATCO Haddonfield station monitor enclosure.

The subway parts of the TTC system were constructed in the 1950s and feature good facility design practices such as straight station platforms, as evidenced in Figure 58. TTC sees the CCTV as serving a two-fold purpose. One purpose is to provide advance warning to the train crew of persons or debris in the right of way at stations. TTC indicated that significant delays result if a train strikes a person or object. CCTV is effective only if these situations can be avoided. A second purpose is to provide rail car side-door observation while the train is berthed in the station and as it begins to pull out. The platforms are straight and unobstructed, which enhances the conductor's ability to see. Toronto's CCTV system approach is unique among those observed by the researchers because it uses platform-mounted cameras and video processing equipment with 9-in.-diagonal monitors mounted in the rail car cab. Figure 13 (see Part I, Chapter 2) illustrates the installation of the monitor in the cab and shows the split-screen image. An RF link is used to transmit camera video images to the rail cars.

To provide advance warning of obstructions in the right of way, the video images are provided to the rail car starting at a point 500 ft outside a station. Beyond the 500-ft range, the system features blanking, which causes the monitor screen to go black when the RF signal is too weak to produce a usable video image. In addition, CCTV images are provided to the rail car for an additional 500 ft after the train leaves the station. This feature is designed to preclude passenger dragging incidents.

Like PATCO, this system uses two cameras per platform and a split-screen image combiner. A benefit of this system approach is that it avoids the problem of fixed monitor location described for CTA and MTA-NYCT. Because monitors are mounted in the cab of the rail car, the RF transmission will support trains of variable length. In addition, the monitor is



Figure 58. TTC Davisville station platform.

closer to the guard, allowing detailed observations of the video images to be made.

### **Southeastern Pennsylvania Transportation Authority (SEPTA)**

SEPTA operates bus service, light rail, regional rail, and rapid transit rail services in the city of Philadelphia and the surrounding counties. For this research program, efforts were concentrated on the rapid transit rail service. SEPTA operates 41 km of rapid rail transit right of way. This consists of the Market-Frankford (Blue) subway/elevated line, the Broad Street (Orange) subway line, and the Ridge Avenue spur, which connects to the Orange line.

The Orange line, including the Ridge Avenue spur, uses single-person crews; the Blue line employs two-person crews. The Orange line has manual train controls—this makes SEPTA unique in North America because it has the only manual system with a single-person crew. Orange line vehicles are not equipped with observation aids and, as a result, operators rely on direct train observation of the vehicle sides. The maximum train length used on the Orange line is five cars, while the Ridge Avenue spur uses no more than two-car trains. The individual cars used on the Orange line are 67 ft 10 in. long over the couplers, making a full-length train 340 ft long. The researchers observed that stations on the Orange line have relatively straight platform edges and minimal platform obstructions.

Excluding the Fern Rock Transportation Center, the Orange line is subway. The station platforms on the lines are a mix of center-island and side platforms. For the center-island platforms on the Orange line, the train operator must leave the control position on the right side of the cab and walk to the left side to operate the doors. This results in a brief (approximately 4 sec) delay in the opening of the doors after the train comes to a stop in a station.

Trains on the Blue line are a maximum of six cars long. The Blue line is a 40/60 mix of subway and elevated stations. The doors on Blue line trains are under control of the conductor, who is in the middle of the train. This person operates the doors and continues to observe as the train leaves the station. In this respect, the door operations on SEPTA's Blue line are equivalent to those on MTA-NYCT, PATH, MBTA, and other two-person crew operations. SEPTA plans to convert operations on the Blue line to single-person crews coincident with the delivery of 222 new rail cars starting in 1996. While these new vehicles will have half-width cabs as opposed to the transverse cabs on the Orange line, they will be equipped with CCTV monitors that will display images of the platform and car doors transmitted from platform-mounted cameras.

This system will employ three or four split-screen image cameras per station platform. These cameras will be mounted in the station and will be housed in protective enclosures. A video switcher will be used to alternate two split-screen images in stations with four cameras, while stations with three cameras will have an alternating split-screen/full-screen sequence. Transmission of video images from the platform will be performed with an RF video link. This video link will use a leaky coaxial cable in the trackbed as the transmission

antenna; the receive antenna will be mounted on the underside of the rail vehicle. The modulation frequency was not selected as of this writing; however, several candidates are possible, including the 905 to 928 MHz and the 2.3 to 2.5 GHz bands.

### **OTHER OBSERVATION AIDS**

During the site visits, the researchers observed an additional system that fits within the scope of observation aids. This system consists of platform gates and proximity warning devices and was seen in use on the Skyway system in Jacksonville, Florida. Although this system is probably not appropriate for most staffed operations, it presents a unique approach for unstaffed systems. Details of this system are provided in the following section.

### **Jacksonville Transportation Authority Skyway**

The Jacksonville Transportation Authority's Skyway system is 0.7 miles long and was opened in 1989. The system operates in downtown Jacksonville and has three stations. Construction of system extensions to the north and south are underway, which will expand the system to 2.4 miles in length. Skyway operates trains that are one-car long. These cars are approximately 50 ft long and seat approximately 20 passengers. Because of the length of the line and light passenger loads, no more than two trains are operated simultaneously. During the visit, only a single train was in operation.

Like the Metromover system in Miami and the SkyTrain system in Vancouver, Skyway is fully automatic. The vehicles are unstaffed, and there is no cab or other provision for a manual backup mode of operation. Automatic voice announcements and warning chimes are used to alert the passengers to door closing and opening. The doors feature an obstruction sensing system that measures door actuator field current. When there is an obstruction, the current will surge. This surge is detected and door recycling occurs. Three attempts will be made to recycle the doors before an alarm is generated and sent to the control center. The control center is equipped with video displays of each platform to permit personnel to assess the situation. As required, the control center operator can dispatch maintenance personnel to clear the doors or can initiate a control override.

A unique aspect of the Skyway system is its system of platform gates and edge warnings. Each station platform has several gates and openings that match the door layouts of the vehicles. Because the trains stop at the same location in the station ( $\pm 14$  in.), the opening in the gates will match the vehicle door openings. Figure 9 (see Part I, Chapter 2) illustrates one such set of gates. These gates run the length of the platform to prevent passenger incursions into the trackbed. Each gate opening is guarded by a pair of photoeyes, and visual references are provided by warning signs, stripes, and colored tactiles. The first set of photoeyes is approximately 12 in. from the platform edge and causes a warning beacon to illuminate and an alarm to sound loudly. When the photoeyes are cleared, the beacon and alarm will turn off after a few secs. The second

set of photoeyes is approximately 3 in. from the platform edge and cause an alarm to be sent to the control center and vehicle power to be removed in the blocks in and around the station. These alarms must be cleared by the control center operator.

There are conflicting schools of thought regarding platform barriers, such as doors, because of considerations such as fire

conditions or emergency evacuations of trains stalled between stations. Within this context, the Skyway is beneficial because it prevents incursions into the right of way by all but determined individuals while ensuring ease of passenger movement in emergency situations.

---