

Karl Küpfmüller, 1928

An early time-domain, closed-loop, stability criterion

CHRIS BISSELL

Karl Küpfmüller (1897–1977) was a German engineer who began his professional career in the comparatively young telecommunications sector just after the First World War. During the 1920s, he worked for eight years at Siemens & Halske in Berlin. From 1928 onward, he held academic posts in electrical engineering, culminating as the chair of telecommunications in Darmstadt until 1963. He appears to have been interned for a short time immediately after World War II as a result of his contributions to the German war effort but was soon released. From 1955–1957, he was president of the German Electrical Engineers Association (VDE). He wrote two classic undergraduate textbooks, one of which [1] remained in print after his death and recently reached its 17th edition [2], posthumously revised by additional coauthors.

While employed at Siemens & Halske, Küpfmüller carried out fundamental work on telegraphy and telephony, network theory, and electrical signal transmission. Like his U.S. contemporary Harry Nyquist, Küpfmüller derived fundamental results in information transmission and closed-loop modeling, including a stability criterion [3].

In contrast to Nyquist, Küpfmüller's name is not well-known in the English-speaking world. Indeed, little has appeared in English about him or his work, although his pioneering results in systems theory informed later American work, particularly through the contributions of Ernst Guillemin, a prolific writer of influential student texts and a renowned engineering educator at MIT. Guillemin was well acquainted with the ideas of Küpfmüller and other German electrical engineers.

The paper [4], which reviews Küpfmüller's work, including his stability criterion for closed-loop systems, provides background and additional references. In the belief that a full English translation of his work on stability is of interest to historians of control engineering, a translation is now available [5].

By the time Küpfmüller wrote [3], he had already developed the rudiments of what we now call linear systems theory. He appears to have been the first researcher to use idealized linear system elements in an abstract way, defined by input-output functions in the time and frequency domains. For example, as early as 1924 he characterized ideal (nonrealizable) filters by a brick-wall frequency response and linear phase [6], whereas others working on similar problems considered realizable devices consisting

of discrete or distributed elements. In this way, Küpfmüller derived general rules of thumb relating to, for example, the relationship between bandwidth and rise time, which were largely independent of the realization of the device in question. Guillemin described Küpfmüller's techniques in volume II of his *Communication Networks* [7], which appeared in 1935.

In [3], Küpfmüller seems to be the first researcher to appreciate the power of adopting a system-theoretic approach to single-input, single-output (SISO) closed-loop systems and to model these systems using generic block diagrams, whatever the nature of the input and output. Indeed, in the introduction to [3] he notes explicitly that his analysis can be applied to a wide range of closed-loop control systems. The main features of his argument are presented below in the hopes of tempting readers to access the full translation online.

KÜPFMÜLLER'S APPROACH TO STABILITY

Küpfmüller begins with a steady-state analysis of a feedback loop, leading to the standard result (even then) that a linear feedback system lies on the edge of instability with continuous oscillations if and only if the loop transfer function frequency response takes the value -1 . Like Nyquist, he realized that this criterion, known as the Barkhausen criterion, was inadequate for an assessment of stability in the general case. Again, like Nyquist a few years later, Küpfmüller took the crucial step of opening the loop, as shown in Figure 1.

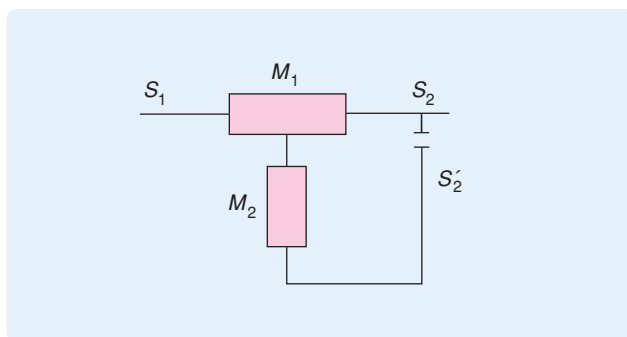

FIGURE 1 Küpfmüller's generic closed-loop system with the feedback loop opened. His use of block diagrams to represent closed-loop linear control systems seems to be an innovation of his 1928 paper and derives from earlier work beginning in 1924 on the dynamic response of linear filters.

Küpfmüller then went on to apply the convolution integral to determine system response. The convolution approach was sufficiently new at that time for Küpfmüller

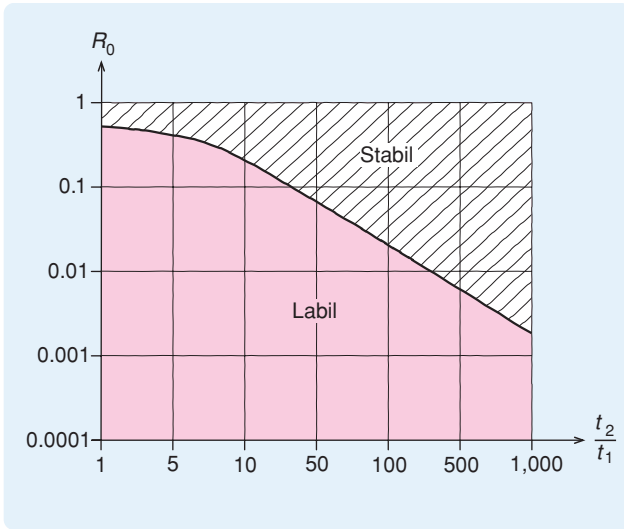

FIGURE 2 Küpfmüller's stability diagram. The quantity R_0 is the critical value of what Küpfmüller terms the *control factor*, a parameter reflecting the loop gain and thus the steady-state error at the stability boundary. The German "labil" means unstable, so the curve defines the boundary between closed-loop stability and instability for an idealized open-loop step response defined by the ratio of total rise time t_2 to dead time t_1 . (Note the incorrect spacing of the vertical gridlines.)

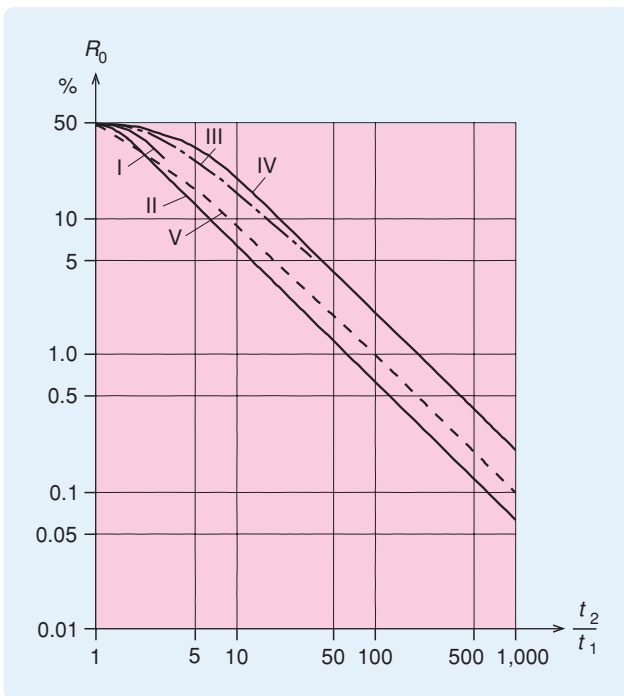

FIGURE 3 Küpfmüller's sensitivity analysis, showing the stability boundary for step responses with various nonlinear rises to a final value. The lowest curve represents a time delay plus a first-order lag, later to become a useful standard process model. The dashed line is Küpfmüller's rule of thumb for the critical control factor to be t_1/t_2 .

to include in [3] a clear, detailed explanation and derivation from first principles of the technique. Unlike Nyquist, however, Küpfmüller does not take the next crucial step of moving into the frequency domain. Instead, he considers only those systems with an idealized open-loop step response that can be modeled by a dead time and a linear rise to a final value. The ratio of total rise time t_2 (including the pure delay) to dead time t_1 turns out to be a useful approximate measure of closed-loop stability. After some iterative computation, Küpfmüller arrives at the stability diagram shown in Figure 2.

Küpfmüller also considers the sensitivity of his step-response model to certain deviations from a simple linear rise as shown in Figure 3. On the basis of Figure 3, Küpfmüller suggests a critical control factor of t_1/t_2 (broken line) as a general rule of thumb for systems of this type.

Particularly interesting is the curve labeled II (the lowest in the figure), which represents a system modeled as a delay plus a first-order lag, which we would now write as the open-loop transfer function

$$G(s) = \frac{K \exp(-sT)}{1 + s\tau}$$

It is instructive to compare Küpfmüller's result for the latter with a classical control analysis. In the above expression, the time delay T corresponds to Küpfmüller's t_1 , while the time constant τ corresponds to Küpfmüller's $t_2 - t_1$. The "control factor" is $1/(1 + K)$. According to such an analysis, if $t_2/t_1 = 5$, then the gain at the stability borderline is approximately 7, corresponding to a control factor of 12.5%. With $t_2/t_1 = 100$, the critical gain is 150 and the control factor is 0.7%. Both of these conditions accord well with curve II in Figure 3. For a system well within the stable region, that is, above both curve II and the broken line in Figure 3, with $t_2/t_1 = 50$ and control factor 5% (gain ≈ 20), a classical frequency response analysis suggests a gain margin of 15 dB and a phase margin of 70°.

Like the Nyquist criterion, the Küpfmüller criterion offers advantages over Routh-Hurwitz. For example, in contrast to Routh-Hurwitz, both the Nyquist and the Küpfmüller stability test can be applied to higher-order electrical systems without excessive calculation. Furthermore, both tests indicate how far a closed-loop system is from the stability boundary. Finally, both tests are easy to apply based on empirical engineering data without an explicit analytic model. The Nyquist criterion, of course, is more general and—particularly with the introduction of the Nichols chart in the late 1940s—gives a far superior indication of the distance from instability. Nevertheless, the Küpfmüller criterion remained in German and Russian control engineering texts until the 1950s.

(continued on page 126)

weights that characterize the relative effects of the noise bounds and the measure of the auxiliary signals. Very importantly, issues related to large-amplitude nonlinear dynamics and the need for feedback approaches are underlined. Also, computational issues related to online applications are discussed along with hybrid and sampled-data systems and stochastic modeling issues such as auxiliary signal design for hybrid stochastic-deterministic systems.

The last chapter includes useful programs provided to demonstrate several of the approaches presented. These programs are available in the MATLAB-like software package Scilab, which is freely available. This chapter adds to the set of practical tools provided in the text and complements the summaries of useful results at the end of most chapters, which are particularly efficient. This last section also supports the examples included in the text, which are in a large measure designed to demonstrate the concepts being presented and less concerned with particular practical applications and their details.

CONCLUSIONS

Aimed at a broad audience that includes graduate students in engineering and applied mathematics, the book is notable for its emphasis and focus on mathematical intuition and numerical issues. It is very well written, with attention to detail and rigor and yet without cluttering the text with

overly pedantic material. While aimed primarily at applied mathematicians and engineers with a background in control, the material is accessible to a wide audience with interests in areas such as control theory, functional analysis, optimization, and theory of differential equations. Examples are provided in many places throughout the text, although exercise problems are not included, which may play a role in deciding whether to use this book as a textbook for a graduate or advanced undergraduate course.

Bogdan I. Epureanu

REVIEWER INFORMATION

Bogdan I. Epureanu (epureanu@umich.edu) received his Ph.D. in mechanical engineering from Duke University in 1999. In 2002, he joined the Department of Mechanical Engineering at the University of Michigan, where he is an assistant professor. His interests include nonlinear dynamics, structural health monitoring, sensors, reduced order modeling of fluid-structural systems (aeroelasticity, unsteady aerodynamics), and control of nonlinear systems. He received the 2004 American Academy of Mechanics Junior Achievement Award, an NSF CAREER Award, the 2003 ASME/Pi Tau Sigma Gold Medal Award, the 1998 A.M. Strickland Prize of the Institution of Mechanical Engineers, and the 2004 Beer and Johnston Outstanding Mechanics Educator Award of the ASEE Mechanics Division. 

» HISTORICAL PERSPECTIVES (continued from page 116)

CONCLUSIONS

Despite the superiority of the Nyquist criterion, Küpfmüller's work should not be underestimated. His generic systems approach was novel and informed much of the later work in this area, mediated (at least for the English-speaking world) by writers such as Guillemin. In German-speaking areas, Küpfmüller is considered to be a major figure of 20th century communications and information engineering. An obituary [8] in 1977 puts it as follows: "With the death of Karl Küpfmüller we have lost one of the fathers of modern communication theory . . . If, today, we recognize information along with energy and matter as a third fundamental building block of the world, then Karl Küpfmüller has been a major contributor to the recognition of this fact."

A NOTE ON THE TRANSLATION

In the full online translation [5], I use English terminology that would have been contemporary with the original publication. When Küpfmüller used terms in German that were (as far as I am aware) later superseded, I have opted for a literal translation, rather than give a modern English equivalent. Readers are invited to send comments or corrections to c.c.bissell@open.ac.uk.

AUTHOR INFORMATION

Chris Bissell (c.c.bissell@open.ac.uk) is professor of telematics at the United Kingdom Open University, where he has contributed to distance learning courses in control engineering, signal processing, telecommunications, and media studies. He has researched the history of technology for many years, concentrating on control and telecommunications in Germany and Russia.

REFERENCES

- [1] K. Küpfmüller, *Einführung in die theoretische Elektrotechnik [Introduction to the theory of electrical engineering]*. Berlin: Julius Springer, 1932.
- [2] K. Küpfmüller, *Theoretische Elektrotechnik: Eine Einführung [Theory of electrical engineering: An introduction]*, 17th ed. (revised and extended by W. Mathis and A. Reibiger). New York: Springer-Verlag, 2006.
- [3] K. Küpfmüller, "Über die Dynamik der selbsttätigen Verstärkungsregler [On the dynamics of automatic gain controllers]," *Elektrische Nachrichtentechnik*, vol. 5, no. 11, pp. 459–467, 1928.
- [4] C.C. Bissell, "Karl Küpfmüller: A German contributor to the early development of linear systems theory," *Int. J. Contr.*, vol. 44, no. 4, pp. 977–989, 1986.
- [5] Classic papers in information and communication technology [Online]. Available: <http://ict.open.ac.uk/classics>
- [6] K. Küpfmüller, "Über Einschwingvorgänge in Wellenfiltern [On transient processes in wave filters]," *Elektrische Nachrichtentechnik*, vol. 1, no. 5, pp. 141–152, 1924.
- [7] E. Guillemin, *Communication Networks*, vol. 2. New York: Wiley, 1935.
- [8] A. Vlcek, "Karl Küpfmüller [an obituary]," *Nachrichten Elektronik*, vol. 32, p. 38, no. 8, 1978. 