

Fundamentals, Troubleshooting & Maintenance of Ash Handling Plants and Pneumatic Conveying Systems for Bulk Materials

By
K. P. Shah

Email: kpshah123[at]gmail.com (Please replace [at] with @)

Committed to improve the Quality of Life



The information contained in this booklet represents a significant collection of technical information on Fundamentals, Troubleshooting & Maintenance of Ash Handling Plants and Pneumatic Conveying Systems for Bulk Materials. This information will help to achieve increased reliability at a decreased cost. Assemblage of this information will provide a single point of reference that might otherwise be time consuming to obtain. Most of information given in this booklet is taken from various sources listed in the references list given at the end of this booklet. For more information, please refer them. All information contained in this booklet has been assembled with great care. However, the information is given for guidance purposes only. The ultimate responsibility for its use and any subsequent liability rests with the end user. Please see the disclaimer uploaded on <http://www.practicalmaintenance.net>.

(Edition: January 2017)

Content

Chapter	Title	Page No.
1	Bulk Materials	3
2	Need for Mechanized Ash Handling Systems	7
3	Types of Ash	9
4	Bottom Ash Handling	11
5	Hydraulic System Fundamentals for Bulk Material Handling	27
6	Pneumatic Conveying of Materials	32
7	Glossary of Pneumatic Conveying Terms	42
8	Fly Ash Handling	46
9	Piping and Fittings for Handling Bulk Materials	58
10	Valves for Conveying Material Pneumatically	65
11	Pneumatic Conveying System Components	76
12	Fly Ash Storage and Unloading Systems	90
13	Gas-Solid Separation Devices	96
14	Safety	101
15	Troubleshooting and Maintenance	103
-	References	124

Bulk Materials

Basic classification of material is made on the basis of forms. They are gases, liquids, semi liquids and solids. Solids are further classified into two main groups: Unit load and Bulk load (materials). Information on characteristics of bulk materials is given in this chapter.

Unit Load and Bulk Load (Materials)

Unit loads are formed solids of various sizes, shapes and weights. Some of these are counted by number of pieces like machine parts and fabricated items. Tared goods like containers, bags, packaged items etc. and materials which are handled en masse like forest products (logs), structural, etc. are other examples of unit loads. Unit loads have been classified by Bureau of Indian Standards' (BIS) specification number IS 8005.

Bulk materials are those which are powdery, granular or lumpy in nature and are stored in heaps. Example of bulk materials are: minerals (ores, coal, etc.), earthly materials (gravel, sand, clay, etc.), processed materials (cement, ash, salt, chemicals, etc.), agricultural products (grain, sugar, flour, etc.) and similar other materials.

Characteristics of Bulk Materials

The successful design of a system begins with an accurate appraisal of the characteristics of the material to be transported. Major characteristics of bulk materials, so far as their handling is concerned, are: lump size, bulk weight (density), moisture content, flowability (mobility of its particles), angles of repose, abrasiveness, corrosivity, etc.

Lump Size

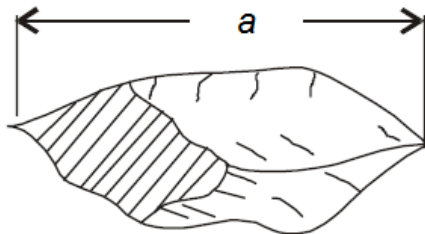

Size of a Particle

Lump size of a material is determined by the distribution of particle sizes. The largest diagonal size 'a' of a particle in mm (as shown in above figure) is called the particle size. The materials may be distinguished as sized (classified) or unsized (non-classified) as follows:

Sized (classified) are the materials for which the ratio between the size of the largest, a_{max} and smallest lump, a_{min} is less than or equal to 2.5.

Unsized (non-classified) are the materials for which ratio a_{max} / a_{min} is greater than 2.5.

Average lump size of a sized material = (maximum particle size + minimum particle size) / 2

Hence, average lump size of sized bulk material = $(a_{max} + a_{min}) / 2$

Sized materials are adequately defined by the values a_{max} and a_{min} . Unsized materials, however, require, in most cases, a complete sieve analysis in which the ratio of the lump size shall not exceed 2.5.

Bulk Density

Bulk weight or bulk density of a lumpy material is the weight of the material per unit volume in bulk. Because of empty spaces within the particles in bulk materials, bulk density is always less than density of a particle of the same material.

Repose Angle

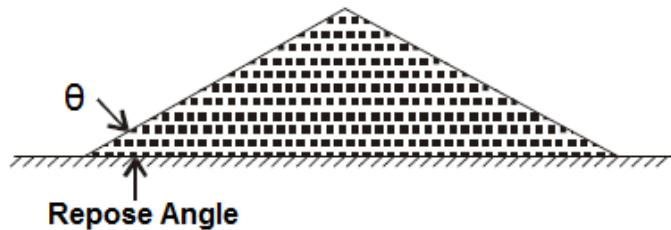

As shown in above figure, when bulk material is dropped on the horizontal surface (ground), it forms a conical heap with certain inclination (angle) with the horizontal surface. This inclination remains more or less of fixed value and is known as repose angle (θ).

Repose angle depends on flowability of the material. The higher value of repose angle signifies less flowability of the material. The repose angle for liquid is zero.

The repose angle of material is an important parameter because it decides the shape and volume of material in stockpiles, storages and conveyance. It may be noted that the repose angle of a material is susceptible to variation in moisture content.

Surcharge Angle

When material is dropped on the horizontal surface, it rests with repose angle if it is falling on stationary surface without internal agitation. If the surface on which it is falling is in vibrating condition, the material tends to settle/spread and will have lesser inclination with horizontal. This reduced inclination is known as surcharge angle.

Abrasivity

The property of particles of bulk materials to wear away the surface they come in contact with when in motion is called abrasivity. The abrasiveness of the material affects the wear of conveyor (pipe) coming in contact with material.

Classification and Codification of Bulk Materials

Codification System as per IS 8730

Classification and codification of bulk materials based on lump size, flowability, abrasiveness, bulk density and various other characteristics have been specified by the BIS specification number IS 8730. The alphanumeric codification system as per this specification is shown below.

Material Code =



- One or more alphabets L to Z corresponding to **miscellaneous characteristics**.
- One alphabet H to K corresponding to **Bulk Density**.
- One number 6 to 9 specifying **Abrasive**.
- One number 1 to 5 specifying **Flowability**.
- One alphabet A to G specifying **Lump size**.

Alphanumeric Codification System as per IS:8730

In this material code, if any of the above characteristics is not known, corresponding number or alphabet is dropped from the material code.

The following table shows the descriptions and limits of the different classes of material characteristics.

Classification of Bulk Materials as per IS 8730			
Material Characteristics	Description of characteristics with Typical Examples	Limits of Characteristics	Class
1. Lump size	Dusty material (cement)	" <i>a_{max}</i> " upto 0.05 mm	A
	Powdered material (fine sand)	" <i>a_{max}</i> " upto 0.05 to 0.50 mm	B
	Granular material (grain)	" <i>a_{max}</i> " upto 0.5 to 10 mm	C
	Small sized lumpy (crushed, iron ore)	" <i>a_{max}</i> " upto 10 to 60 mm	D
	Medium sized lumpy (chipped wood)	" <i>a_{max}</i> " upto 60 to 200 mm	E
	Large lump materials	" <i>a_{max}</i> " upto 200 to 500 mm	F
	Especially large lump size (boulder)	" <i>a_{max}</i> " over 500 mm	G
2. Flowability	Very free flowing (cement, dry sand)	Angle of repose: 0°- 20°	1
	Free flowing (whole grains)	Angle of repose: 20°- 30°	2
	Average flowing (anthracite coal, clay)	Angle of repose: 30°- 35°	3
	Average flowing (bituminous coal, ores, stone)	Angle of repose: 35°- 40°	4
	Sluggish (wood chips, bagasse, tempered foundry sand)	Angle of repose: > 40°	5
3. Abrasiveness	Non-abrasive (grains)	-	6
	Abrasive (alumina)	-	7
	Very abrasive (ore, slag)	-	8
	Very sharp (metal scraps)	Cuts belting of conveyors.	9
4. Bulk density	Light (saw, dust, peat, coke)	Up to 0.6 t/m ³	H
	Medium (wheat, coal, slag)	0.6 to 1.6 t/m ³	I
	Heavy (iron ore)	1.6 to 2.0 t/m ³	J
	Very heavy	2.0 to 4.0 t/m ³	K
5. Miscellaneous characteristics	Please refer the following table.	Note: Sometimes more than one of these characteristics may apply.	L to Z

Miscellaneous Characteristics of Bulk Materials as per IS 8730	
Miscellaneous Characteristics	Class
Aerates and develops fluid (or dual operating) characteristics	L
Contains explosive (or external) dust	M
Sticky	N
Contaminable affecting use or saleability	P
Degradable, affecting use or saleability	Q
Gives off harmful fumes or dust	R

Highly corrosive	S
Mildly corrosive	T
Hygroscopic	U
Oils or chemicals present. May affect rubber products.	W
Packs under pressure	X
Very light and fluffy (or very high flowability and dusty). May be wind swept	Y
Elevated temperature	Z

BIS specification number IS 8730:1997 lists 486 different bulk materials with their bulk densities, flowability properties and codes.

Material characteristics and codes as per IS 8730:1997 for some common materials are given in the following table.

Material Characteristics and Codes as per IS 8730:1997				
Material	Average Bulk Density, kg/m³	Angle of Repose, Degrees	Recommended Maximum Inclination, Degrees*	Material Code
Alumina	800-1040	22	10-12	B27M
Ashes, fly	640-720	42	20-25	A58
Bagasse	112-160	-	-	E56Y
Bauxite, mine run	1280-1440	31	17	B38
Cement, Portland	1500	39	20-23	A27M
Cement, Clinker	1200-1520	30-40	18-20	D38
Clay, dry, lumpy	960-1200	35	18-20	D37
Coal, anthracite, sized	960	27	16	C27
Coal, bituminous, mined, classified	960	35	16	D36QT
Coke, petroleum calcined	560-720	-	20	D37Y
Copper ore	1920-2400	-	18-20	D28
Earth as excavated dry	1120-1280	35	20	B37
Iron ore	1600-3200	35	18-20	D37
Iron ore, crushed	2160-2400	-	20-22	C27
Iron ore, pellets	2500-2880	20	12	D28 & D28Z
Lignite, air dried	720-880	-	-	D26
Lignite, raw, heavy	900-960	38	22	D37T
Limestone	1360-1440	30-45	-	-
Limestone, crushed	1360-1440	38	20	A26M
Limestone, dust	1360-1520	38-45	18	A57M
Phosphate, triple, super, ground fertilizer	800-880	45	30	B56T
Phosphate rock, broken, dry	1200-1360	25-30	12-15	D27
Phosphate rock, pulverized	960	40-42	25	B37
Salt, common dry, coarse	720-800	30-45	18-22	C27TU
Salt, common dry, fine	1120-1280	25	11	D27TUW
Sand, bank, dry	1440-1760	35	16-18	C37
Sand, foundry, prepared	1440	39	22	D38
Sand, foundry, shakeout	1440	39	22	D38
Sand, silica, dry	1440-1600	30-35	10-15	B28
Sulphur, crushed	880-960	30-45	16	C36MS
Sulphur, powdered	880-960	30-45	21	B36MW
Urea, prills	700	23-27	13	C26SU

* The angle of inclination is for conventional belt conveyors which allow free rollback of material.

Need for Mechanized Ash Handling Systems

Mechanized ash handling systems developed as the size of coal fired boilers increased beyond the sizes permitting manual handling of large quantity of ash. In a coal based thermal power plant, huge amount of ash is generated which has to be disposed off continuously. Typically for a 2x500 MW plant based on Indian coal, the amount of ash generated is around 300 to 400 TPH depending on gross calorific value and ash content of worst coal. Generally, systems utilizing pipes are used to remove ash from the boiler and auxiliaries to a remote disposal location because conveying systems utilizing pipes offers the greatest flexibility for routing.

Importance of Ash Handling System

Fly ash handling systems affect power plant availability through their interaction with the electrostatic precipitator (ESP) and bag house requirements to meet today's environmental quality standards. Today's ESP & bag house must perform at high efficiency with high reliability since a poorly performing system can cause either partial or complete boiler shutdowns.

MOE&F Notification

The MOE&F (Ministry of Environment and Forests, India) notification dated 03.11.2009, stipulates for 100% ash utilization within four years of commissioning for new plants and reduced land area (50 hectares for a 500MW unit using 45% ash coal) for emergency ash pond. The ash handling plant should therefore, adopt the following modes of operation.

Fly Ash Disposal

Fly ash should be disposed in dry mode (for normal continuous operation) and in wet slurry mode or high concentration slurry disposal (HCSD) mode (for initial operation period till 100% dry fly ash utilization is achieved and emergency operation when the dry disposal is interrupted).

Bottom Ash Disposal

Bottom ash should be disposed in wet or semi- wet mode.

In view of above, ash handling system covers evacuation of ash and its disposal in wet, semi wet and dry form and consists of numerous equipment which works in a coordinated manner to achieve ultimate functional need.

Useful and Saleable Commodity

It is also very important to collect fly ash efficiently as it is now useful commodity and is saleable.

Ash Handling Systems

Ash is conveyed manually, mechanically, pneumatically and hydraulically. Mechanical systems typically include submerged or dry-flight conveyors, screw conveyors, and belt conveyors. Pneumatic systems may be positive or negative pressure, as described later. Hydraulic systems are also known as sluice systems and may be used independently or in combination with pneumatic systems. The pneumatic and hydraulic systems utilize pipes. In

ash handling systems, the pipe utilized for conveying ash is termed the conveyor or conveyor line.

Information on construction, design considerations, working, troubleshooting and maintenance to handle bottom ash and fly ash systems is given in the following chapters. Though the chapters are written to handle ash, the information can be used to handle other bulk materials also after modifying the system based on characteristics of the material.

Types of Ash

The ash is produced in two forms viz. fly ash which is of fine texture and bottom ash which is comparatively coarser. Information about bottom ash and fly ash is given in this chapter.

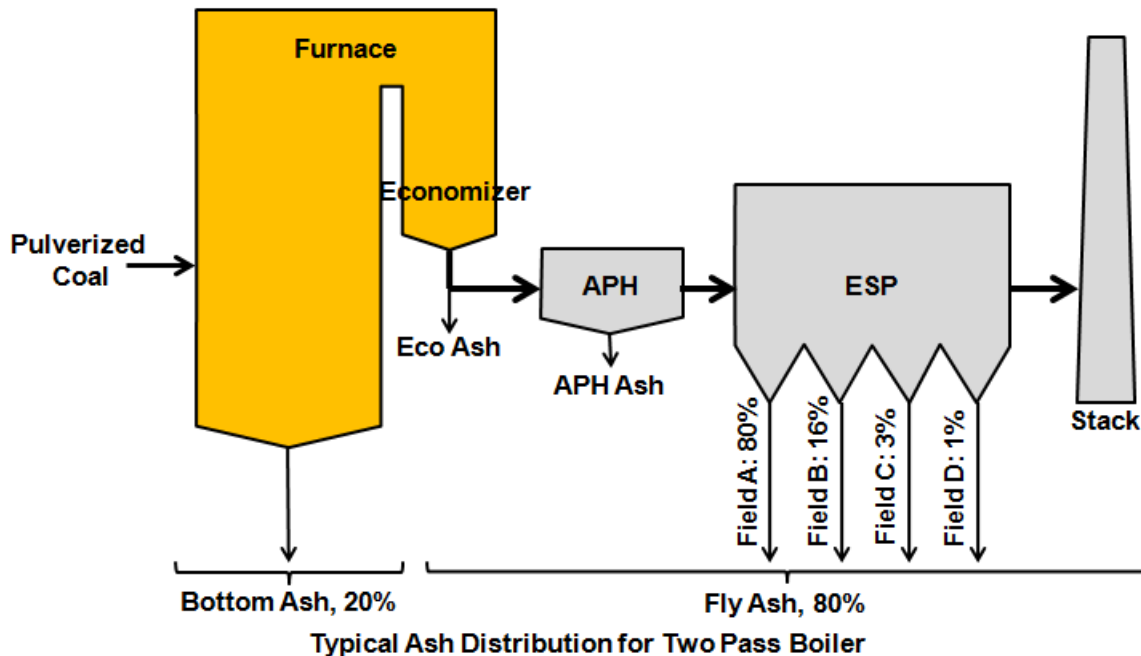

Bottom Ash

As shown in the above figure, the ash and slag which falls at the bottom of the boiler furnace is called bottom ash.

Bottom ash is the solid products of combustion that have sufficient mass, either as a monolith or as an agglomeration of smaller particles, to fall against the gas flow to the bottom of the furnace.

The slag is formed when ash that fouls the heat absorbing surfaces of the furnace builds up to the degree that it melts (no longer cooled by the steam or water inside the boiler tubes); the melted ash then becomes slag, an amorphous, glassy material. Ultimately the weight of accumulated slag increases, which causes it to fall to the bottom of the furnace. The situation is aggravated whenever the ash has a low fusion temperature.

Bottom ash is usually fairly uniform in size and shape. It generally runs from 1/8 inch to 1/4 inch, and is flake shaped. However, periodic slagging in the furnace causes formation of clinkers that can range from 1 inch to several feet in size, and have random shapes. The large clinkers (greater than 1 foot) are usually a result of operating a boiler at non-design conditions. Bottom ash can leave the furnace at a temperature of up to 1900°F, but is cooled by the water in the ash hopper to a temperature in the range of 120°F to 180°F.

It is important that bottom ash is sized to avoid plugging problems. The maximum dimension of the ash (or slag) should not exceed one-half the inside diameter of either the bottom ash conveying pipe or the jet pump throat (if the system has a jet pump). Ash and slag are reduced to these dimensions by clinker grinders, which are also called "crushers".

Fly Ash

Fly ash is the particulate products of combustion that are light enough to become entrained in the gas stream, and that would exit the stack if not removed by pollution control equipment. Hence, ash captured in electro static precipitator (ESP) or bag house, economizer, air preheater and stack is called fly ash.

Fly ash drops down wherever the flue gas stream changes direction or its velocity reduces.

Economizer Ash

Economizer ash, although often classified as a fly ash, frequently contains pebble and stone like particles from 1/4 inch to 2 inches in size that mainly result from soot blowing. Sometimes ash sinters while sitting in a collection hopper. This is due to operation of the boiler that results in either high carbon ash or high excess air. Economizer ash particles have no typical size. The temperature of this ash ranges from 600°F to 900°F.

Air Preheater Ash

Air preheater ash is usually finer and more uniformly sized than economizer ash. The particle sizes range from 100 to 800 microns, while the ash temperature ranges from 250°F to 400°F.

Electrostatic Precipitator Ash

The size of the fly ash particles entering the ESP can range from 0.01 micron to 1000 microns.

Maximum ash is collected in the front hoppers. In general, for low carbon ash, the coarsest ash is collected in the front hoppers, and the finest ash in the rear hoppers.

Generally, when coal is burned in a pulverized coal-fired boiler, bottom ash generation is about 20% and fly ash generation is about 80%. Since only a small amount of ash is collected in economizer hoppers, air preheater hoppers and stack, ash collected in ESP hoppers is generally considered to be 80%.

Compositions of Ash

The compositions of ash directly affect the performance of the ash handling system. The items of greatest importance to ash handling are the percentages of SiO_2 , Al_2O_3 , Fe_2O_3 and CaO .

SiO_2 , is an abrasive form of glass. Al_2O_3 , alumina, is one of the most abrasive materials known. Fe_2O_3 is iron oxide, another abrasive. All of these causes wear on components of the ash handling system.

CaO or lime (and sodium, whenever present) causes ash to become cementitious. If the total amount of such compound(s) exceeds 20% by weight, neither a wet handling system nor a wet conditioning system should be used. If these constituents are from 10% to 20% by weight of the ash, caution is advised.

Bottom Ash Handling

Bottom ash is handled using hydraulic system, submerged scraper conveyor system and dry bottom ash system. Information about these systems is given in this chapter.

Hydraulic System and Components

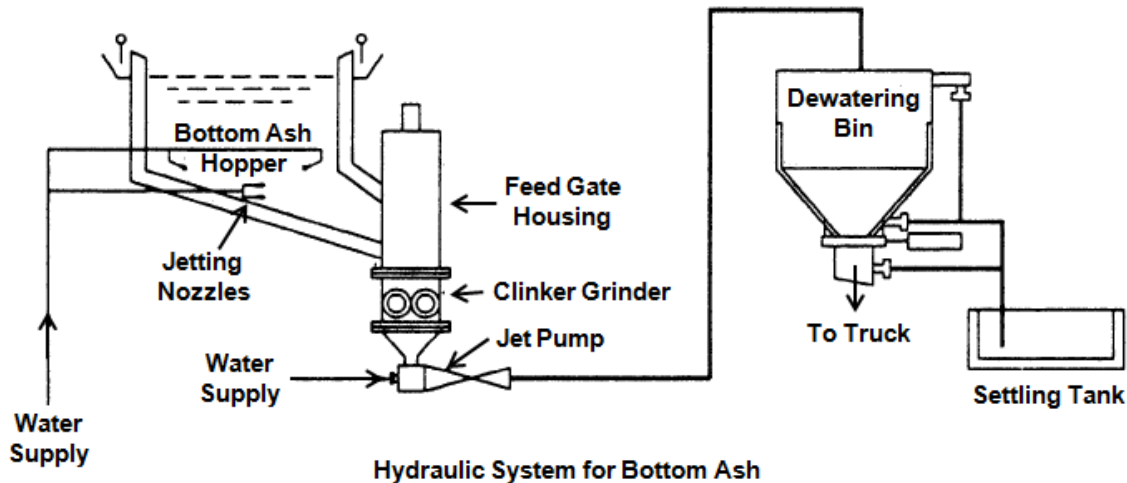

As shown in above figure the bottom ash/slag from the furnace is quenched in water and collected in a self-supporting water impounded ash hoppers installed directly under the boiler for periodic removal. Ash hopper is constructed in carbon steel with refractory lining for side and bottom or refractory lining for side and hard burnt paving brick for bottom. The hopper discharge can be arranged either centrally or at side. A hydraulic cylinder operated feed gate housing closes the discharge opening. The material from the discharge opening flows into a single-roll or double-roll clinker grinder for properly sizing the material. Clinker grinder crushes the ash clinkers. The water and solid granular material (slurry) is conveyed by a jet pumps and pipeline to:

- Ash pond area in the direct (gravity) disposal system (maximum distance 1500 m).
- Ash slurry sump in the pumped disposal system for longer distances.
- Dewatering bins to dewater the ash for trucked disposal.

Bottom Ash Hopper

The primary function of bottom ash hopper is to receive and temporarily store bottom ash that has fallen from the combustion area of the furnace.

The pool of impounded water in a bottom ash hopper is intended to:

- Protect the hopper (both the refractory and the steel) from furnace heat radiation.
- Provide a volume of cool water that shatters large masses of hot slag that fall into the hopper.
- Cushion the hopper against the impact of the slag.

A bottom ash hopper should store, as a minimum, the amount of ash that is produced at MCR during an 8-hour shift, with some extra capacity for safety. An optimum storage capacity is in the range of 10 to 12 boiler hours' output.

To assure that the impounded ash discharges from the hopper, especially on unattended automatic systems, it is recommended that the slopes of a hopper bottom should not be flatter than 40°. For a small hopper and extreme volume requirements, 30° slopes can be considered as an absolute limit. In such a case, jetting nozzles must be added at the upper ends of the sloped sides to assure moving the ash to the discharge point. Jetting nozzles are also provided for dislodging ash and cleaning the hopper at the end of every deashing cycle.

The maximum effective slope distance of a jetting nozzle is generally taken to be 13 to 15 ft. If the slope length exceeds this, two banks of nozzles are used. The first bank is at the top of the slope and the second bank approximately half way down. The nozzles in each bank should be spaced approximately 2 ft. apart. Water is supplied at a pressure of about 100 psi. Higher pressures are not recommended because the water stream then rat-holes through the impounded ash rather than moving it down the slope.

While jetting nozzles on slope help to move ash downward toward the discharge doors, the converging geometry of the bottom of the compartment can cause packing and arching of the ash. To guard against this condition, a pair of nozzles is placed on the wall opposite the feed gate and aimed through the opening. The feed gate nozzles are usually activated just before opening the feed gate to agitate and dilute the compacted ash at the bottom of the hopper. They normally operate during the entire cycle of discharging ash from that particular compartment, but can be turned off if necessary to conserve water. The water pressure is about 100 psi.

Because of the recommended 40° limit on the bottom slope angle, longer hoppers must have multiple compartments to fill the length requirements. A hopper with a single compartment is usually called a “V” type. A hopper with two compartments is usually referred to as a “W” type and those with three compartments are usually called “3V” types.

To protect the steel plate of the hopper from corrosion, abrasion, impact, and the effects of high temperature, the inside of the hopper is lined with refractory material.

To prevent refractory failure due to differential expansions between the refractory and the hopper plate, the inside surface of the steel plate should be painted with two coats of bitumastic asphalt before the refractory is applied. This effectively connects the refractory to the anchor system for support and reinforcement, but separates the refractory from the hopper steel. The spacing of the anchors is very important. It is recommended to place anchors at 15 inch, centers, minimum (vertical and horizontal).

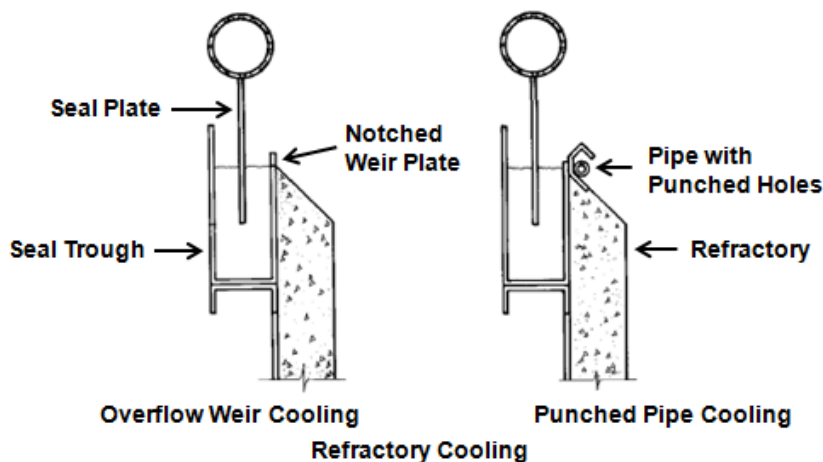

Because refractory is exposed to heat of the high temperature boiler gases and radiant heat, it would have a short life (especially at the water line) if it is not protected. As shown in above figure, protection for the refractory is provided by a curtain of cooling water, which is introduced at the top of the refractory and cascades down the vertical refractory wall to provide the required cooling and heat absorption. The two usual means of introducing this refractory cooling water are either through a notched weir plate or through a supply pipe that has holes punched in it. In either case, the water source is located at the top of the refractory wall and supplied with cooling water. It is recommended to specify a system with supply pipe that has holes punched in it as it is more reliable.

One requirement of the bottom ash hopper is that it must have a pool of water, which causes falling slag to shatter. This shattering and disintegration is due to thermal shock, and is most effective if the impounded water temperature does not exceed 140°F. This temperature is maintained below 140°F by the cooling water for the refractory cooling and the refill water connection if refractory cooling water quantity is inadequate.

As bottom ash particles inevitably get into the seal trough, it is necessary to periodically flush the trough to remove the accumulated sediment. As flushing sediment from the seal trough is very important, this operation should not be left to chance or depend on memory. It is recommended that this function should be automated, even for manual or remote manual systems. Seal troughs should be flushed at the end of each conveying cycle, and at least once each day.

Feed/Discharge/Sluice Gate

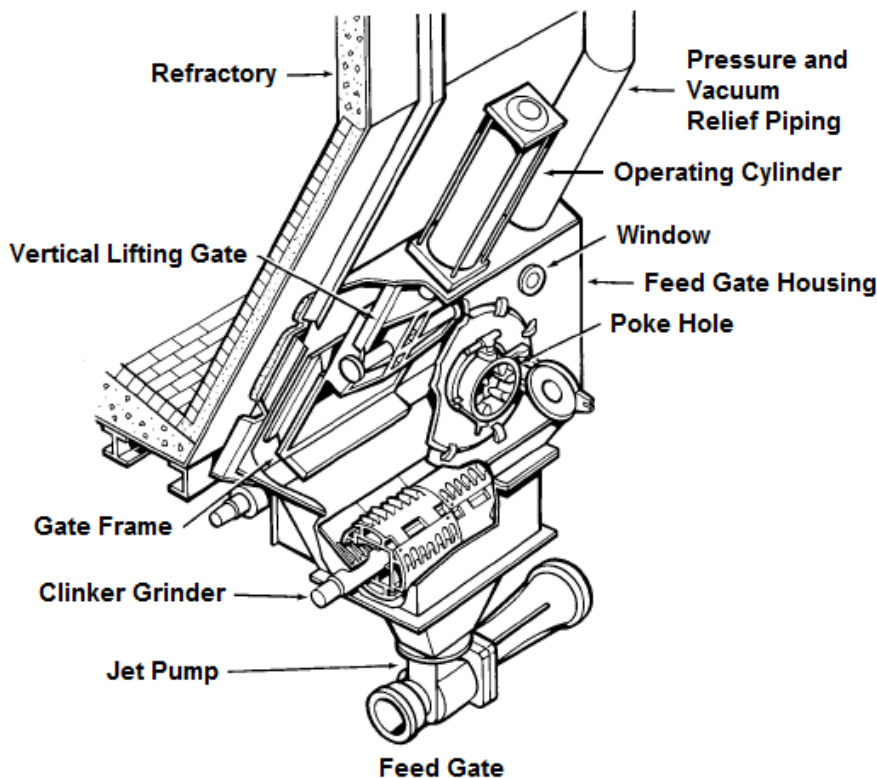

As shown in above figure, the feed gate is placed inside water tight housing, which also supports the clinker grinder and provides observation and access to the feed gate. The water tight housing placed around the feed gate should be fabricated from plate at least 3/8 inch thick. Carbon steel is usually adequate.

The feed gate should be designed such that the gate seat and face are not in contact while the gate is being positioned, but that they are tightly wedged together when the gate is closed.

Feed gates can be placed on both (opposite) sides of each hopper compartment to increase redundancy of installed equipment.

The feed gate housing should be equipped with the following.

- Waterproof flood light
- Observation window(s)
- Pressurized access door(s)
- Pressure and vacuum relief valves/piping
- Dilution water spray
- Manual jetting nozzle

Pressurized Access Door (Poke Hole)

Even though the vast majority of boilers are balanced draft units, the pressurized or aspirated poke hole is recommended for maximum operator safety in the event that a boiler puff or transient occurs while an operator is using the poke hole. A poke hole is shaped like a venturi, with a compressed air manifold oriented so that an air flow is induced into the boiler. This arrangement assures that when the poke hole is opened for visual or rodding access, the resulting flow is ambient air into the boiler instead of boiler gases out of it. As a pressurized poke hole seals only the outflow of gases, not water; it should never be opened unless it is above the hopper water level.

Pressure and Vacuum Relief Valves/Piping

While the ash system pump is operating (whether jet pump or mechanical pump), the feed gate housing is subject to significant negative pressure if the discharge gate is closed or blocked. Conversely, if the discharge door is closed and the sluice line becomes plugged or blocked, the gate housing is subjected to positive pressure. To safeguard against either case, feed gate housing should be fitted with both pressure relief and vacuum relief valves/piping.

Dilution Water Spray

Dilution spray pipe is a minor but important accessory to be specified for inclusion in the feed gate housing. It is a water spray pipe with holes in it to add water at a low pressure (about 50 psi). It is placed near the housing outlet. This is necessary whenever the bottom ash hopper is full of ash and the ash that comes out of the feed gate is very concentrated. The concentrated ash overloads the jet pump (which tries to clear itself with nozzle water as described in jet pump). The net result is a very slow feed of ash into the pipeline. The dilution spray pipe adds enough water to increase the rate of transport.

Manual Jetting Nozzle

The feed gate housing should also be fitted with a manual nozzle aimed through the center of the feed gate opening for emergency jetting. This is used to dislodge and move ash or clinkers that become stuck in the feed gate opening.

Low Leakage Sluice Gate

Following figure shows construction of a low leakage sluice gate manufactured by United Conveyor Corporation, U.S.A. It significantly reduces door leakage associated with earlier sluice gate designs with two and four rollers. This gate differs from the standard model primarily in the method used to wedge the door against the seat. The wedging arrangement distributes the closing force on the door to the points where most leakage occurs.

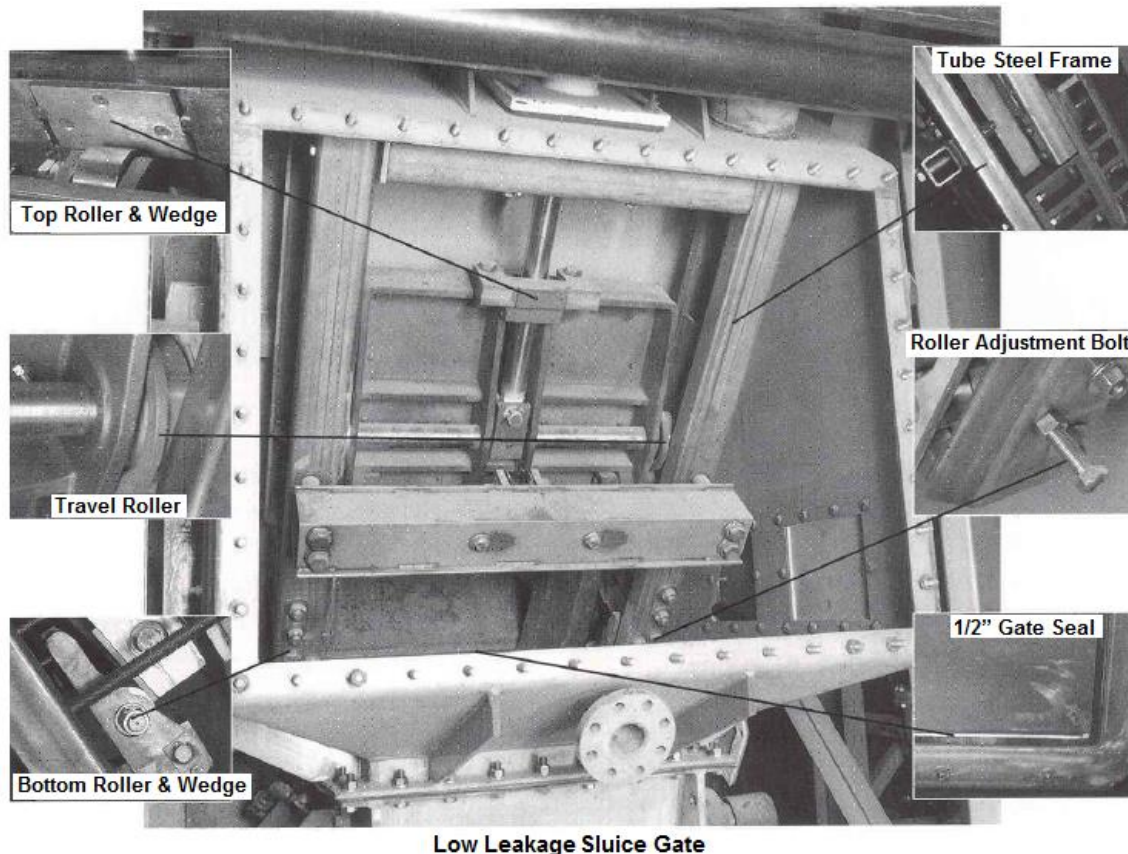

The standard gate design uses the same rollers to both wedge the gate in place and guide the gate during up and down travel. The wedging action places a high stress on these rollers which can result in wear of the rollers. This wear can then interfere with the up and down travel. The low leak design uses two rollers for travel and three separate rollers for wedging. This separation greatly reduces the stress on the travel rollers promoting more reliable up and down travel. The gate seat has 6 mm thick elastomer backing sheet sandwiched between the stainless steel face plate and the gate face to provide a flexible sub-surface. The elastomer can deform at a rate different from the face plate to provide better mating of the face plate to the seat.

The sluice gate is cylinder operated, using a hydraulic cylinder or an air-over-water cylinder instead of direct pneumatic operation for closer speed control. Just before the gate completely closes, the three strategically located wedges engage the three rollers. As the cylinder continues to extend, the rollers ride up on the wedges forcing the gate face against the seat, forming a tight seal.

The design of the low leak sluice gate is based on a geometric principle: three points determine a plane. This gate has three sets of wedges and rollers - one set at the top center of the gate, the other two sets at the bottom left and right corners of the gate. The following figure illustrates the advantage of the three-point design.

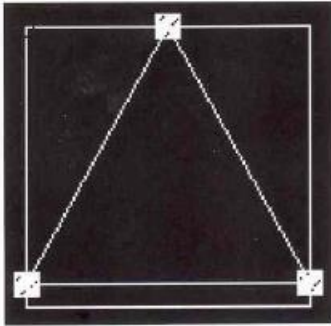

Three Rollers Design
Three rollers determine the plane of the gate to minimize leakage at all points.

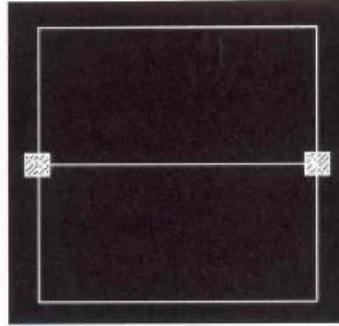

Two Rollers Design
Two rollers may permit leakage at the top or bottom of the gate.

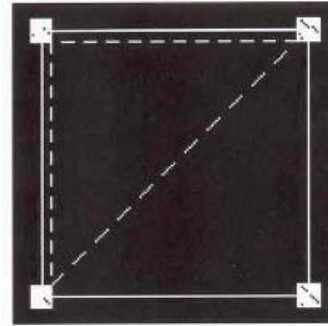

Four Rollers Design
Three of the four rollers determine the plane of the gate, allowing leakage at one corner.

Advantage of Three Roller Design

Clinker Grinders

The two principal types of clinker grinders/crushers are classified by the number of rotating elements; i.e., single-roll clinker grinders and double-roll clinker grinders.

A fluid coupling is used in a clinker grinder for soft start and overload protection. Should extremely hard or excessively packed material stop rotation of the rolls, the motor is automatically reversed for a few revolutions by a self-reversing motor starter.

The roll/s are mounted in a cast iron or fabricated steel housing, but coated and stainless steel housings are also available.

Generally, stuffing boxes are provided to prevent grit or water from leaking around the shafts into the bearings. A lantern ring (usually of teflon) is installed in the stuffing box (at the end of the stuffing box adjacent to the grinder roll).

When wet material is handled, a small amount of filtered water should be supplied to the lantern rings at 5 psig greater than the hydrostatic head. Compressed air is used when handling dry material. The flow passes from the lantern ring, through the clearance space around the shaft and into the interior of the grinder. This flow effectively prevents grit and water from entering the stuffing box. Packing rings are located on the opposite side of the lantern ring. These confine the clear water and keep it from flowing in the opposite direction. Generally, the gland follower is spring loaded to keep compression on the packing rings. Shaft sleeves protect portions of the shafts inside the stuffing box.

Alternatively, a mechanical seal is installed instead of a stuffing box in accordance with maintenance and operational requirements.

It is recommended to select clinker grinders such that the pieces sized by them are not larger than one-half the inside diameter (ID) of the smallest pipe in the system. This will prevent plugging when several pieces pass together through elbows.

Single-roll Clinker Grinder

Bottom ash, although hard and abrasive, is friable, a property that a properly designed single-roll grinder uses to advantage. The grinder splits or shears the ash between the single roll and breaker plate.

Because there are only two shaft openings through the housing, there are fewer potential leak points than any double-roll grinder as shown in the following figure.

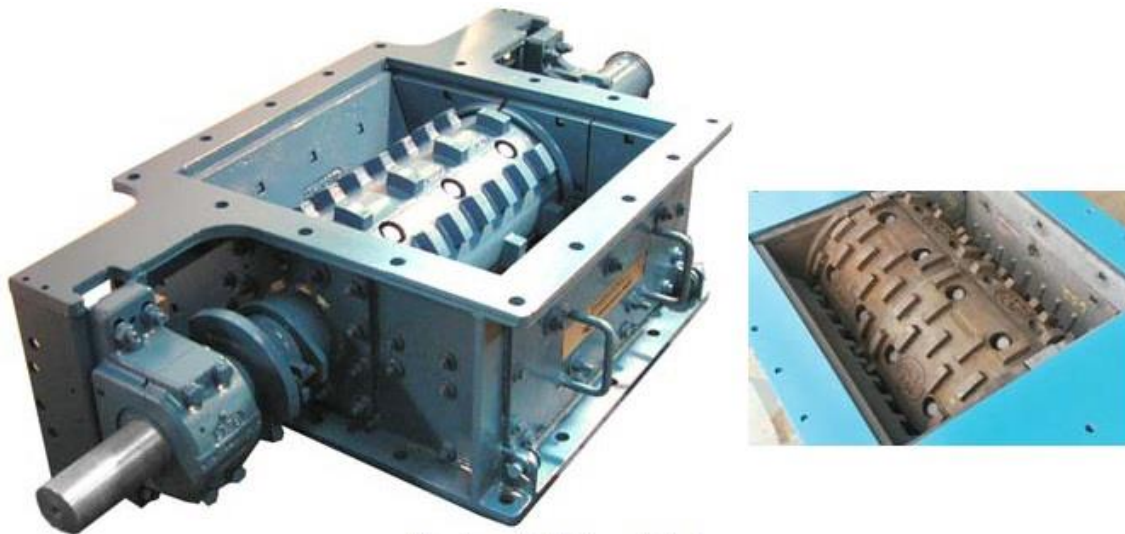

Single-roll Clinker Grinder

Since the single-roll grinder does much of the breaking by attrition, the roll and breaker plate are subjected to more wear.

Generally, roll and breaker plate are constructed of a high-chrome, cast iron material with a minimum Brinell hardness of 600. To extend their life, roll segments are usually reversible. Wear plates are abrasion-resistant steel.

Double-roll Clinker Grinder

The double-roll grinder can accept and crush larger pieces than a single-roll grinder with a comparable roll diameter. The double-roll design is used to "grab" and pull material into the crusher to handle it in most severe operating conditions. Because the double-roll grinder crushes by applying tremendous pressures at a few points, frictional wear is minimized. Solid pieces break along the natural lines of cleavage when pressure is applied.

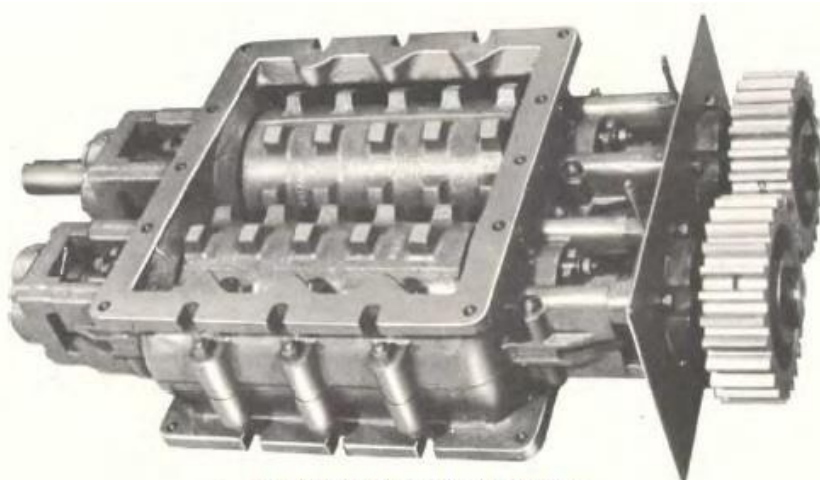

Double-roll Clinker Grinder

As shown in above figure, two manganese steel rolls on fixed centers rotate toward each other and reduce large pieces to the desired size. Grinder rolls are constructed of either

manganese steel that hardens with use under impact (work hardening) to a BHN of 450 or Ni-hard rolls that already have an "as-cast" hardness. Ni-hard grinder rolls are ideal for grinding the softer bottom ash.

However, the double-roll grinder has higher first (initial) cost, is costlier to maintain and requires more power to operate.

Injectable Packing System

For clinker grinders, injectable packing system dramatically improves grinder shaft packing performance. This system completely eliminates the need for flushing water injection.

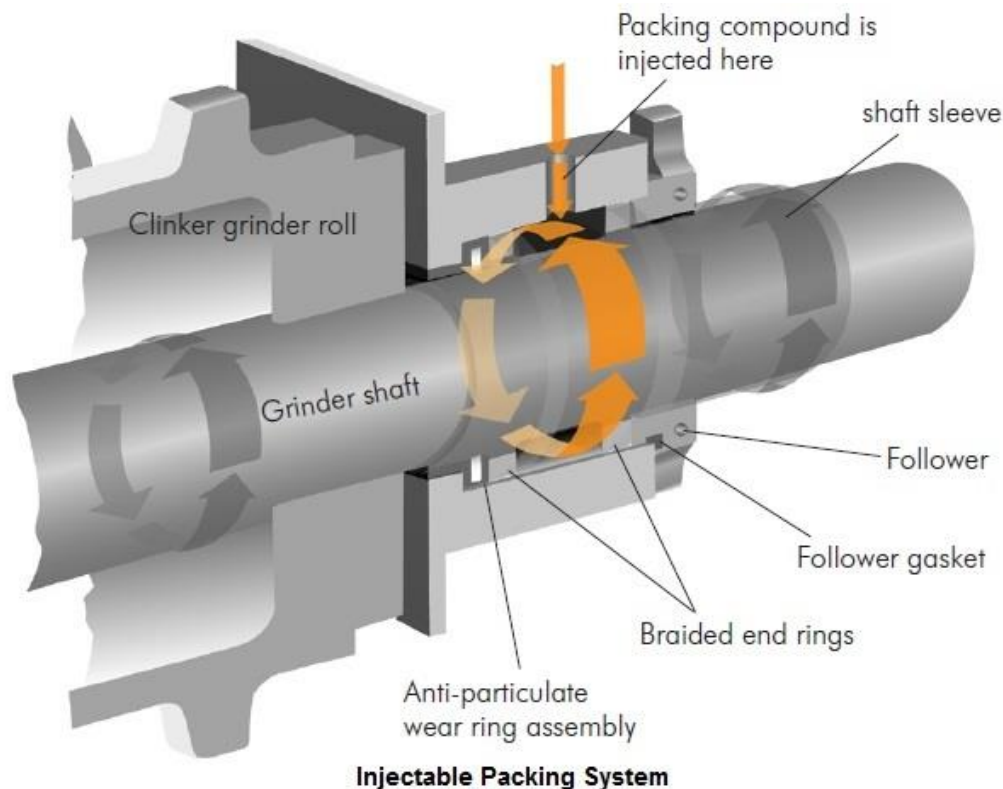

In this system a fibrous, flexible injectable packing compound fills the stuffing box to uniformly surround the grinder shaft and lubricate it while in use as shown in above figure.

Because the packing compound conforms to both the shape of the shaft and the stuffing box, it withstands shaft wear and prevents formation of leak paths. Reduced leakage may radically decrease bearing failure and maintenance time.

The system allows for renewable sealing as needed, simply by pumping more packing material into the chamber.

For more information, please see website of Allen-Sherman-Hoff, www.a-s-h.com.

Jet Pump

A jet pump is a water powered venturi device for removing slurry or liquid from a vessel or sump to which the jet pump is connected. It is also called hydro ejector.

Following figure shows construction of a jet pump. Jet pumps are designed for bottom ash, mill rejects, pyrites and other low capacity applications. Jet pumps transport a mixture of water and solid, granular material through a transport pipeline. Nozzles are made of stainless steel or tungsten carbide and are available in different sizes for different capacity.

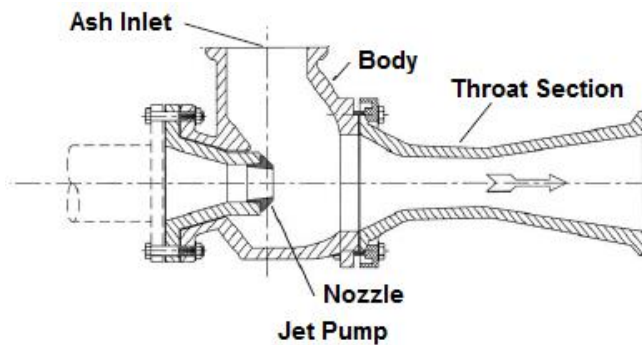

When a jet pump operates, high pressure water is delivered through the nozzle to create a vacuum. Ash/water slurry is drawn into the inlet and the combined total is discharged through the outlet.

Dewatering Bin

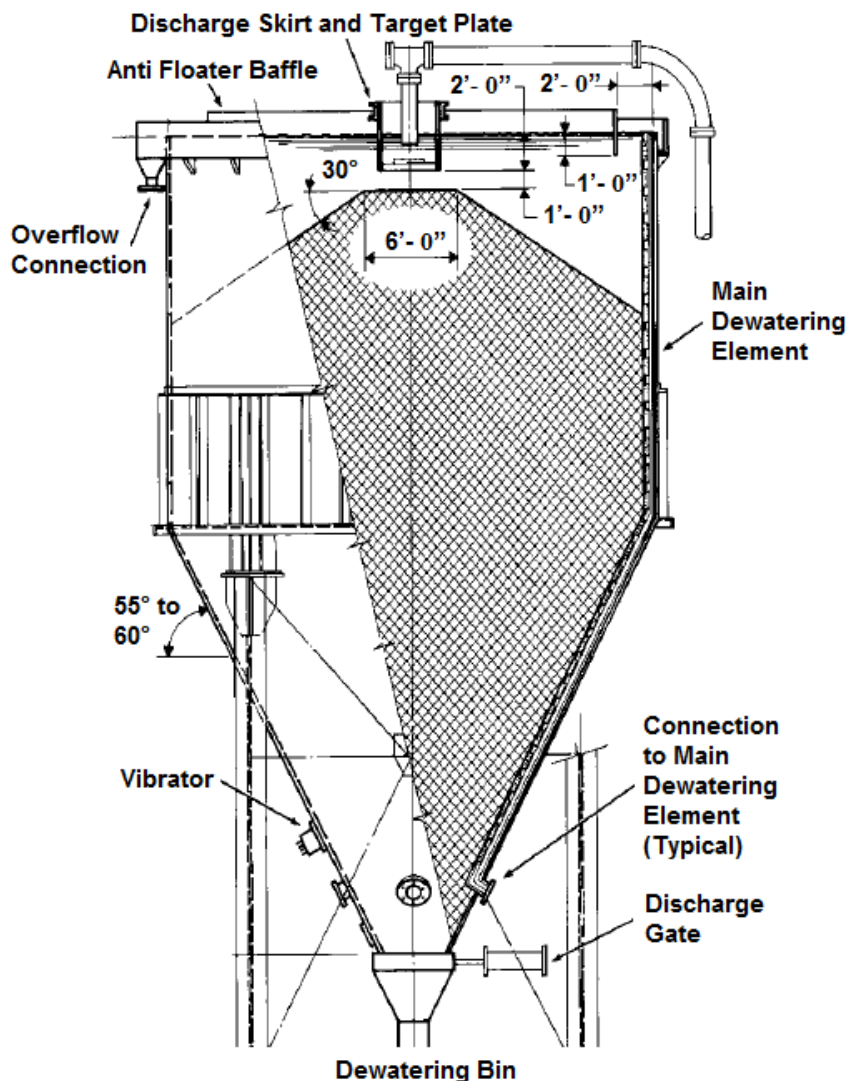

Dewatering bins separate the ash and conveying water and temporarily store the ash until it is removed. Usually this is by trucks.

Above figure shows construction of a typical dewatering bin. It is a cylindrical tank with a conical bottom terminating in a discharge opening. To assure that dewatered ash discharges from the outlet, a fairly steep cone angle is required. The quasi-standard in the industry of 55 to 60° from the horizontal is recommended. Typically, they are constructed of 3/8" mild steel plate. However, they can also be constructed with alloy materials for exceptionally corrosive conditions.

Most commercial standard designs for dewatering bins discharge the ash slurry against either a target plate or bar screen. Both have the same intent: to “throw” ash particles outward to the sides of the dewatering bins, thus causing more complete filling. An additional claim made for the bar screen is that it allows fine particles to go straight through and throws coarse particles to the sides. There they act as a filter, to prevent the fines from clogging the screens of the dewatering element.

To minimize short circuiting of incoming mixtures of water and fine ash particles directly to the overflow weir, a circular skirt is usually provided around the discharge point. It should extend 2 to 3 feet below the normal water level. This prevents the initial downward velocity of the water and ash from being dissipated too rapidly, and retains sufficient differences between the downward velocity of ash particles and the rise rate of the water being displaced.

As bottom ash is formed in the furnace, some clinkers are developed that are either porous, or contain sufficient gas pockets to cause the clinkers to float. In the dewatering bin, these “floaters” can eventually reach and then travel over the overflow weirs into the drain. These floaters can plug the drain piping system. To prevent this, an overflow baffle is used. This is a circumferential skirt that extends from approximately 1 foot below the water line to somewhat above the water line. Floaters collect against this baffle until the bin is full, and are discharged with the ash whenever the bin is emptied.

All major vendors offer main dewatering elements with quite similar components. Stainless steel screens are placed either over steel pipe with windows cut out, or alternatively, over steel channels as is shown in the following figure.

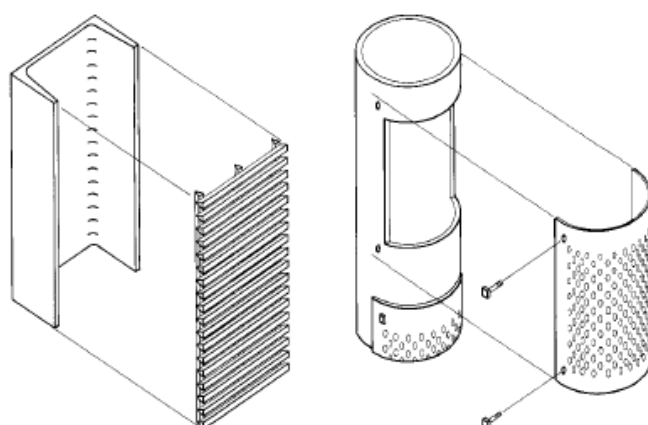

Non Clogging Bar Screen Punched Plate Screen
Main Dewatering Element Construction

The number of main dewatering elements is, or should be, a function of the bin diameter. The following is recommended.

Bin Diameter	Number of Main Dewatering Elements
up to 16 feet	4 Elements at 90°
16 feet to 25 feet	6 Elements at 60°
26 feet to 35 feet	8 Elements at 45°
36 feet to 45 feet	10 Elements at 36°
46 feet to 55 feet	12 Elements at 30°

The main dewatering elements should have screens with holes from 1/16 to 1/8 in. (diameter or slotted) punched on staggered centers 1 1/2 times the diameter. Screens with the minimum recommended size (1/16 in.) openings minimize the amount of fines carryover during dewatering. Conversely, the larger size (1/8 in.) opening allows some additional carryover but dewateres more quickly.

Most vendors also furnish a type of dewatering element that extends as far down into the bin cone as possible, and is intended to remove water not drained through the main elements.

Vibrators are furnished as a standard part of the dewatering bin package by most vendors, and should be specified to be furnished.

Usually the water from dewatering bin is sent to a settling tank where carryover dust is allowed to settle. Clarified water then overflows into an ash water sump. Ash water sump supplies water to ash water pumps. A jet pump located in settling tank or sludge pump is occasionally used to purge or clean the settled material back to dewatering bin.

Submerged Chain/Flight Conveyor System

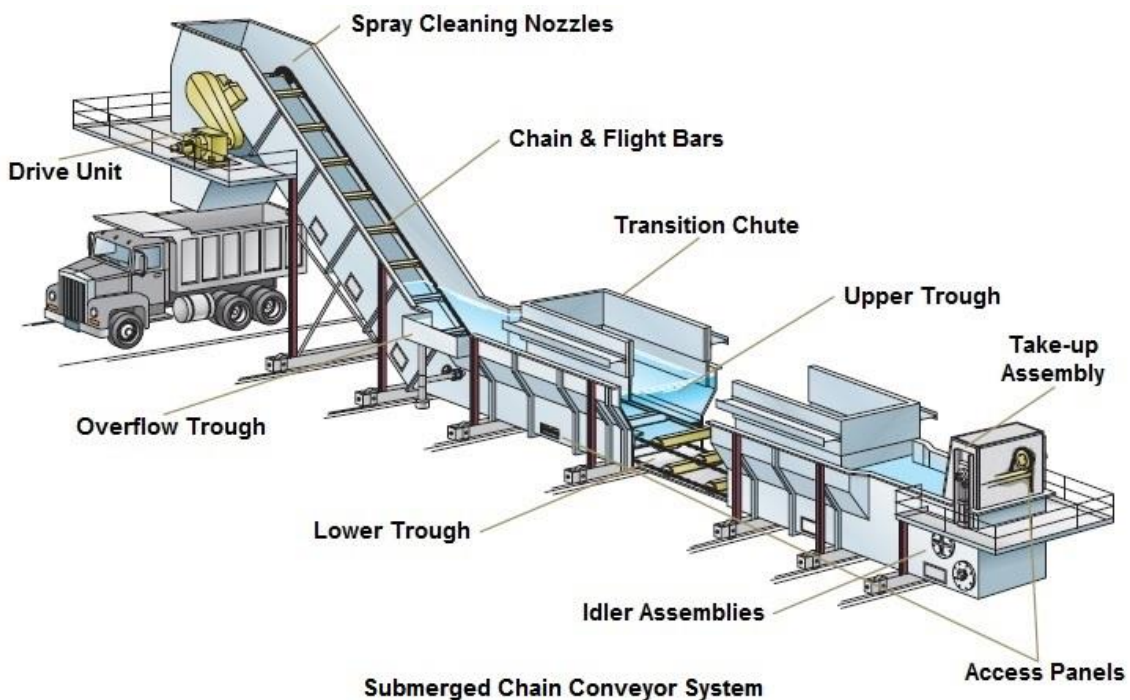

Submerged chain conveyors (SCC) are used due to many advantages including power, water, steel, installation and space savings. As shown in above figure, for bottom ash applications, the submerged chain conveyor system receives the hot ash and slag/clinkers falling from the boiler through a transition chute to the water filled trough. The transition chute provides an air tight seal between the boiler and the conveyor. The water quenches and cools the hot ash and slag, shattering some of the large clinkers as a result of thermal

shock. The ash then settles to the bottom of the conveyor and is conveyed by flight bars to an inclined section of the system for dewatering, producing a manageable product. At the top of the incline, a discharge chute directs the ash into a storage bin (through belt conveyor) or truck.

A pair of chains is driven continuously along the length of the conveyor. Flight bars are connected to the driven chains on each side. They sweep across the upper trough, the inclined section and return through the lower trough.

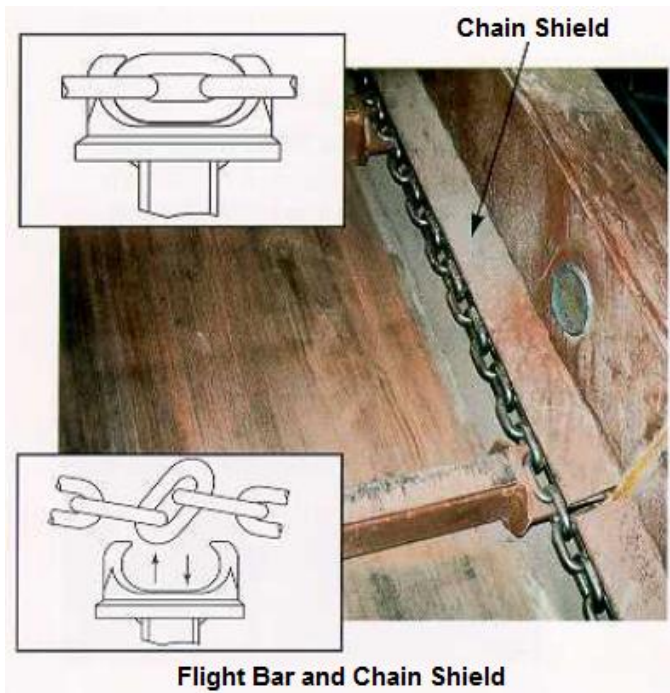

As shown in above figure, the flight bars are generally fabricated from rectangular hollow steel tubing, with chain connectors welded to the ends of each bar. Replaceable, abrasion resistant wear plates (approximately 400 BHN) are stitch welded to the top and bottom of each bar. The chain connector is an open horn which surrounds a horizontal link of the drive chain (It is recommended that the flight bars shall not be welded or bolted to the chains, but attached in a manner that reduce chain wear). The flight can be placed at any point along the chain. The chain shield is welded to the side of the trough along the entire length to deflect falling material away from the chain. It protects the chain from direct impact by ash and slag.

Submerged scraper conveyors use a high strength round link chain system and are designed to withstand high shock loads. Water spraying nozzles at the top of the conveyor incline clean the chain prior to engaging drive sprockets. This reduces chain and sprocket wear, thereby extending the life of the chain. The chain links are generally case hardened (to a minimum depth of $0.09 \times d$, d being the wire diameter) to 750 HV (approx. 700 BHN) and designed to withstand high shock loads. The chain should tolerate temperatures up to 200°C (360°F) without loss of surface hardness.

The chains are manufactured in matching pairs to assure uniform length. The length tolerance of matched chain strands is 0.05% or 3 mm maximum. The chain, if replaced, should be replaced as a matched set on both sides. Many suppliers provide drive sprocket in which individual teeth of the drive sprocket can be adjusted using shim plates. This feature allows for up to 5% chain wear, permitting nearly twice the useful life of the chain as compared to other chain systems without such facility.

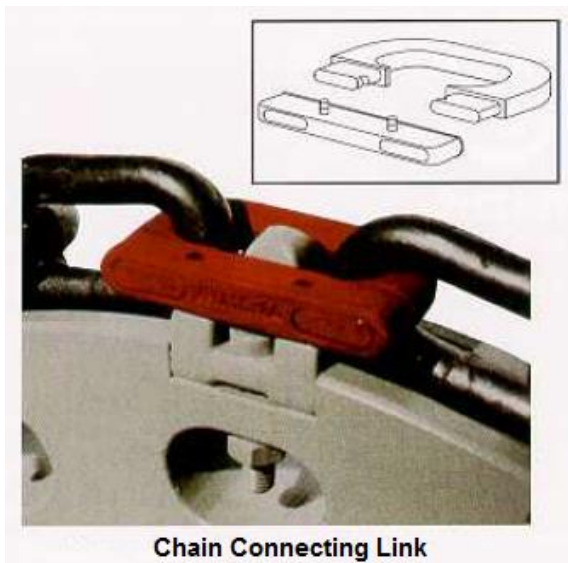

Chain Connecting Link

As shown in above figure, chain connecting links are inserted in the chain as horizontal links. If the connector is secured with roll pins, no screws or bolts are required.

Usually the chain and flight bars are driven by a variable speed drive unit through the head sprockets at the top of the incline. The drive should be equipped with a torque limiting device to protect the drive train. Chain tension and adjustment is made by tail shaft take up units at the back end of the conveyor.

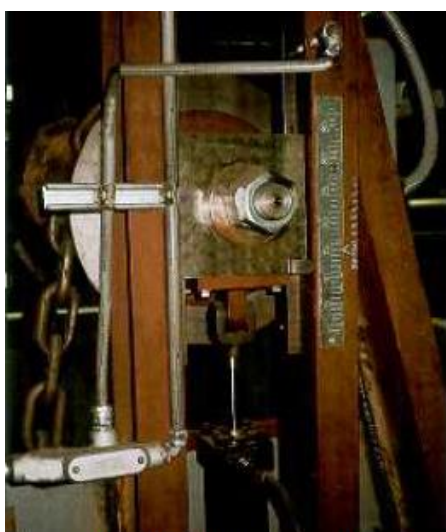

Hydraulic Chain Tensioner

The tensioner may be provided with a compression spring operated device or hydraulic cylinder. Above figure shows the chain tensioner with a hydraulic cylinder. An integral visual indicator on the tensioner gives immediate indication of the extent of chain wear.

Upper trough is constructed of minimum 3/8" (10mm) carbon steel, stiffened to withstand hydraulic forces and falling slag impact. Typically, the bottom of the upper trough is lined with renewable 1" (25 mm) AR400 abrasion and impact resistant steel for longer wear life. AR400 is having hardness of 360 - 440 BHN. Abrasion resistant side wear liners are placed along the sides.

USA designers recommend installation of carbon steel bars from side to side of the conveyor, approximately one foot below the water surface to provide lateral stability to the conveyor and to cause any large ash/slag pieces to be sheared before impacting the trough.

The dry lower trough houses the return run chain and flights and extends the entire length of the conveyor. The return row is lined with AR plate or basalt. Removable metal panels on the lower trough provide accessibility for conveyor chain and flight bar inspection or replacement.

The submerged scraper conveyor can be fixed installed or mounted on trolley wheel so that it can be rolled out for maintenance.

The submerged scraper conveyor system is also ideal for handling mill rejects. Mill rejects are typically stored in a hopper within close proximity to the mills and then periodically sluiced hydraulically to the submerged scraper conveyor where they are conveyed and dewatered with bottom ash.

Dry Bottom Ash System

MAC™ by Magaldi

The patented MAC™ (Magaldi Ash Cooler) dry bottom ash system is a unique system for dry extraction, cooling and handling of bottom ash from pulverized coal-fired boilers.

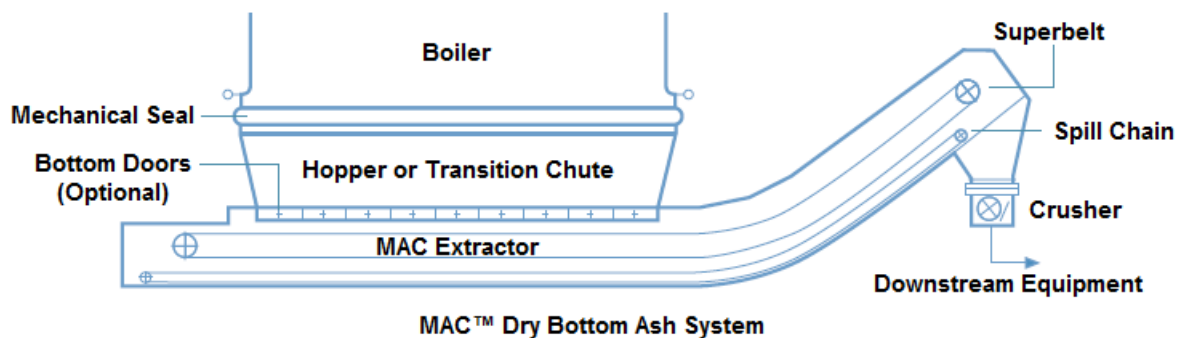

The main component of the MAC™ System is the MAC™ extractor shown in above figure, which is designed to operate in harsh conditions including exposure to high temperatures and shock loads caused by the fall of large clinkers. The MAC™ extractor is connected to the boiler throat through a refractory-lined hopper or a transition chute, which provides a volume for temporary ash storage. The hopper is available with bottom doors which can be closed to isolate the MAC™ extractor and for ash storage. The hopper or transition chute is connected to the boiler throat by a high-temperature mechanical seal that allows for boiler expansion.

Operation

A key element of the MAC™ extractor is the Magaldi superbelt which receives and extracts bottom ash falling from the boiler. The superbelt is enclosed inside the sealed casing of the MAC™ extractor. During the conveying of ash on the superbelt, ash is cooled by a small, controlled amount of ambient air that flows by natural draft into the MAC™ system casing through inlet valves. In addition, the air provides oxygen to the unburned ash, allowing a more complete combustion and return of heat to the boiler.

From the MAC™ extractor, the cooled ash is discharged onto a crusher, which reduces the large ash clinkers to a size suitable for conveying to a silo.

Any ash fines that fall on the casing floor are swept off by the spill chain, a small scraper conveyor installed under the superbelt.

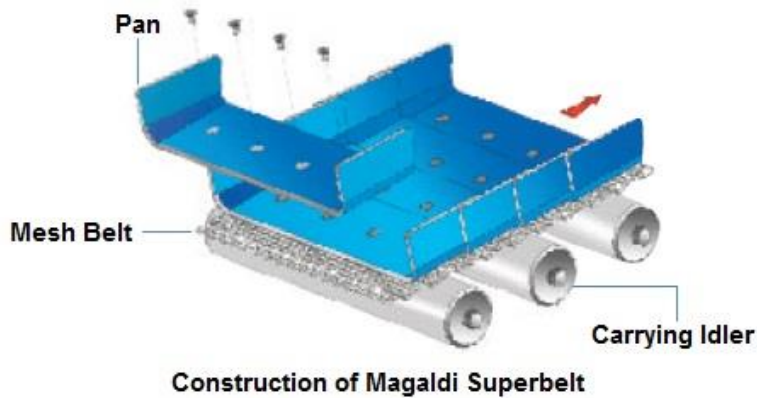

As shown in above figure, the superbelt is constructed with a stainless steel mesh belt that carries partially overlapping stainless steel pans, making the belt conveyor almost completely sealed.

The patented method of connecting the pans to the mesh belt leaves all components free to expand in any direction, without permanent deformation. As a result, the superbelt withstands the high temperatures encountered under the boiler throat.

The superbelt is supported by carrying idlers that are mounted across the entire width of the belt to provide support for heavy mechanical impacts. All idler bearings are fitted outside the casing to protect them from heat and allow easy lubrication. The driving force is transmitted by friction between the head pulley and the belt, while a pneumatic take-up device on the tail pulley supplies a constant tension. Wear of the belt is minimized because normally there is no relative motion between the belt and the ash.

Since the ash is delivered dry, there are several options available for the configuration of the equipment downstream of the crusher.

For more information, please see website of Magaldi: www.magaldi.com

DRYCON™ by Clyde Bergemann

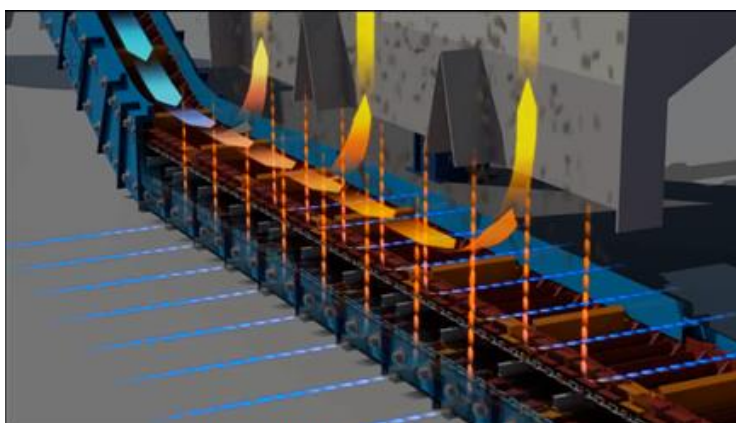

DRYCON™ Dry Bottom Ash System

As shown in above figure ambient air is induced into the DRYCON™ at the top end and along the length of the steel apron plate conveyor by the negative pressure in the furnace. Air travels in a counter flow direction along the surface of the ash which rests on the conveyor. A re-burning process of the glowing ash is activated which reduces the unburned carbon level and frees up additional thermal energy. This additional energy released from the hot ash heats the air and adds further thermal energy to the steam generating process within the boiler. To ensure that the combustion and gas exhaust composition processes is not adversely affected, no more than 1 - 1.5% of the combustion air is introduced to the boiler.

DRYCON™ is supplied by Clyde Bergemann. For more information on the system, please see website of Clyde Bergemann: <http://www.cbpg.com>.

Hydraulic System Fundamentals for Bulk Material Handling

Information on fundamentals and design considerations for handling bulk material hydraulically is given in this chapter.

Definitions

Hydraulic conveying is the transportation of solids in a moving mass of liquid, usually in a pipeline, but sometimes in a trench or flume.

Slurry is a mixture of solids and liquid. **Sludge** denotes mud or concentrated slurry having a considerable amount of fine material that imparts high viscosity. Typical examples of slurries are the solid-liquid mixtures encountered in mineral processing plants and dredged material from waterways and dams. Most of the slurries are made up with water. However, industrial paints, coal-oil mixture, and coal-methanol slurries are made up with liquids other than water.

Design of a slurry piping system involves

- Selection of pipe diameter
- Estimate of friction loss and pumping requirements
- Selection of pipe material, valves, and fittings
- Selection of pumps
- Selection of instruments and control system for safe and reliable operation

Pipelines transporting liquids such as oil and water can be operated at any velocity up to their design limits. However, in most slurry applications, a certain minimum velocity needs to be maintained, to keep solids from settling out in horizontal sections of the pipe. The velocity below which particles tend to settle out and form a deposit in the pipe is called the **deposition velocity**. The pipe diameter should be selected such that the velocity in the pipeline is maintained above the deposition velocity over the operating range of flow rates.

The operating flow rate range is determined by the expected range of solids throughput and slurry concentration. **Solids throughput** is defined as the weight of solids to be transported per unit time. It is normally expressed in tons per hour (tons/h). The **slurry concentration** is expressed as the weight of solids per unit weight of slurry, or volume of solids per unit volume of slurry.

The deposition velocity and friction loss in a given size pipe at a given concentration depends upon the slurry flow behavior. The selection of pipe material, valves, fittings, and pumps depends upon the velocity of flow, abrasivity of the slurry, and pumping pressures which are in turn governed by the slurry flow behavior.

Slurry Flow Behavior

Flow of slurry in pipes depends upon the interaction between the solids and liquid as well as between the slurry and the pipe.

Depending upon the velocity of flow, pipe diameter, solid's size distribution, fluid properties, and solids characteristics, four different flow conditions can be encountered in a horizontal or nearly horizontal pipeline. These are homogeneous flow, heterogeneous flow, intermediate regime, and saltation regime.

Homogeneous Flow

Homogeneous flow implies that the solid particles are uniformly distributed across the pipeline cross section. Homogeneous flow, or a close approximation to it, is encountered in slurries of high concentrations and fine particle sizes. Slurries exhibiting homogeneous flow properties do not tend to settle and form a deposit under flowing conditions. Typical examples of homogeneous slurries are sewage sludge, clays, drilling mud, paper pulp, fine limestone (cement kiln feed slurry), thorium oxide, and many other finely ground materials.

Heterogeneous Flow

In heterogeneous flow conditions, there is a pronounced concentration gradient across the pipeline cross section. Slurries at low concentration with rapidly settling (coarse particles) solids generally exhibit heterogeneous flow. Typical examples are sand and gravel slurries, coarse coal slurries.

Intermediate Regime

This type of flow occurs when some of the particles are homogeneously distributed while others are heterogeneously distributed.

Saltation Regime

The fluid turbulence may not be sufficient to keep fast settling particles in suspension. The particles travel by discontinuous jumps or roll along a sliding or stationary bed on the pipe bottom. This type of flow will occur with coarse sand and gravel slurries.

Hydraulic Conveying Categories

Hydraulic conveying of materials may be classified in to following three categories.

- High concentration slurry disposal system
- Conventional lean slurry system
- Hydraulic ejector or jet pump system

High Concentration Slurry Disposal (HCSD) System

This system uses significantly less water, using 15% water or less by weight, and is used generally to transfer high throughputs of fine fly ash over very long distances using high pressure diaphragm pumps with velocities of around 2 m/s. However, proper monitoring of the slurry properties (homogenous mixing of ash and water) is the key to success of this system. Systems such as this have been installed for over 10 kilometer transfer distance. Ash disposal at the ash mound is very simple as the ash solidifies easily into an inert mass and the system does not produce the waste water problems or leachate problems normally associated with ash lagoons because literally no water is released at the disposal area. De-blocking facility is also considered either by the HCSD pump itself or through a separate water pump.

Key advantages of this system are: lower water consumption, lower pipeline size, and lower power consumption.

Conventional Lean Slurry System

This system uses a motorized pump (generally centrifugal) to transfer a water / ash mixture at high throughputs over long distances to an ash pond or lagoon. This can also handle both very coarse and fine ash with lumps of up to 50 mm.

Hydraulic Ejector or Jet Pump System

This system uses a water induced vacuum to evacuate material from a collection point or hopper and transfer it to a local sump. This type of system can handle large ash lumps (up to 50mm) but is limited to around 30 tons per hour (tph) transfer rate and 200 metres distance. Water to ash ratio is around 4:1 by volume.

Long-Distance Pipelines

Because of the relatively large investment required for a long-distance pipeline, it is generally advantageous to adjust the characteristics of the slurry to suit the pipeline requirements. The slurry concentration, particle size distribution, and throughput are generally controlled within relatively narrow operating limits. The material is generally finely ground to obtain a pseudo-homogeneous flow condition in the pipeline.

Because of the relatively long length of these pipelines, pressure losses through bends and fittings are not a significant part of the total friction loss. Pumping requirements should include changes in pipeline elevation which could be substantial in long-distance pipelines traversing rugged terrain.

Slurry pipeline systems range from single-station low-pressure centrifugal pump installations to multi-station high-pressure reciprocating pump systems. In all cases, the basic requirement for successful slurry pumping is to maintain pipeline flow above a minimum operating velocity. The minimum operating velocity is set at a desired margin of safety above the critical velocity. The critical velocity in turn is determined by the solids screen analysis, solids density, and concentration as well as the specific system characteristics - pipe diameter, slurry temperature, etc.

Design Considerations

Hydraulic (Sluice) pipe requires to be designed for freeze protection depending on ambient temperature and may be pressurized to discharge or gravity flow to discharge.

The pipe wall thickness must be sufficient to withstand the expected maximum pressure in the pipe and expected corrosion-erosion effects on the pipe wall during the intended operating lifetime. Most pipelines are designed to have a service life of at least 10 years.

In a slurry pipeline, metal loss is expected to be a result of corrosion with possible erosion of the corrosion products taking place simultaneously. Under some conditions, mechanical abrasion will play a part in producing the metal loss.

Erosive wear (abrasive) is governed by the size, shape, angularity of the solids, slurry concentration and velocity of flow. In a slurry pipeline, these parameters are interdependent to some extent. For example, use of large solids requires an increase in minimum transportation velocity. It has been found that above some critical velocity, the abrasive wear increases as the cube of slurry velocity. Wear also increases as the size of the solid particles increases. Thus, by reducing the size of the solids, the abrasive wear can be substantially reduced due to the combination of lower required velocity and reduction in wear due to

smaller particle size. The effect of slurry concentration on the abrasive wear is more complicated.

From experience, it has been found that the metal loss due to abrasion is insignificant if the velocity of flow is less than about 10 ft/s (3 m/s). For long-distance slurry pipelines, velocities in the range of 4 to 6 ft/s (1.2 to 1.8 m/s) result in an optimum design from the standpoint of economics. Thus, when possible, a particle size should be selected so that the slurry is nearly homogeneously suspended at velocities of 4 to 6 ft/s (1.2 to 1.8 m/s).

Corrosion can be controlled by passivating either the anodic or the cathodic reaction at the pipe wall. Elimination of dissolved oxygen and the adjustment of slurry pH can reduce the corrosion rate substantially. In most long-distance slurry pipelines carrying mineral concentrate, the slurry pH is adjusted to 9.0 or higher, using lime to reduce the corrosion rate.

Hydraulic systems use quite a variety of pipe materials depending on the length of the run and the longevity required for the pipe. Steel or cast iron is normally a minimum with chromium cast-iron fittings and straight sections after changes in direction, when conveying fly ash. Bottom ash may require steel or cast iron, but basalt-lined steel, ceramic-lined steel and fiberglass-reinforced epoxy with ceramic is also used. Basalt is a castable igneous rock with relatively low melting temperature and high abrasion resistance.

Significant life extension can be achieved with regular rotation of pipe, as most abrasion occurs on the bottom.

Slurry Pumps

Centrifugal as well as positive displacement pumps are available for pumping slurry. The positive displacement pumps can be divided into piston, diaphragm, and plunger pumps. Piston pumps can be used for relatively less abrasive materials while the diaphragm and plunger pumps are used for handling abrasive slurries at high pressures. The initial capital costs and maintenance costs of positive displacement pumps are higher than those of centrifugal pumps, but their hydraulic efficiency is 85 percent, compared to about 60 to 70 percent for the centrifugal slurry pumps. The flow rate per pump is limited in the case of positive displacement pumps while the head developed per pump is limited to about 40 m in the case of centrifugal slurry pumps.

Centrifugal pumps are extensively used for pumping slurry under relatively low pressure. The main advantages of these pumps are as follows:

- High flow rates can be achieved with a single unit at a relatively low initial cost.
- There is no practical restriction on the maximum size of solids that can be handled (In case of reciprocating pumps, the maximum size of particles that can be pumped is restricted by the check valve seal requirements).
- They are simple to operate and maintain.

Centrifugal pumps have the following shortcomings:

- The maximum discharge head is limited to less than 130 ft (40 m) for a single stage pump. With several pumps in series, a maximum pressure of about 750 psi (5.17 MPa) can be achieved.
- Seal liquid is required for good packing life. The seal liquid dilutes the slurry. The amount of dilution could become significant when the slurry passes through a number of pumps.

The centrifugal pump parts exposed to wear from slurry are the casing, impeller, and gland seal. Mechanical shaft seals often are ineffective in slurry installations. A seal that incorporates a liquid flush to keep solids from entering the gland is necessary.

To obtain good service, the casing and impeller should be lined with abrasion resistant material. Both rubber-lined and "Ni-hard" (metal-lined) units are used extensively. The size of the solids to be pumped determines the type of pump to be selected. Rubber-lined pumps are generally used with particles up to about 0.375 in (9.5 mm), and Ni-hard pumps are used for coarser slurries. However, if material with sharp cutting edges is being pumped, such as crushed glass, Ni-hard pumps can be used even for relatively fine solids. Rubber-lined pump parts usually have longer service life with fine materials. Coal is one material for which Ni-hard line pumps have shown better parts life than rubber-lined units.

To obtain good pump parts life, it is good practice to limit the impeller tip speed to less than 4000 ft/min (1220 m/min). The pump parts life on units running faster than this speed drops in proportion to the square of the impeller tip speed.

Pneumatic Conveying of Materials

Pneumatic conveying systems are simple and suitable for the transport of powdered and granular materials.

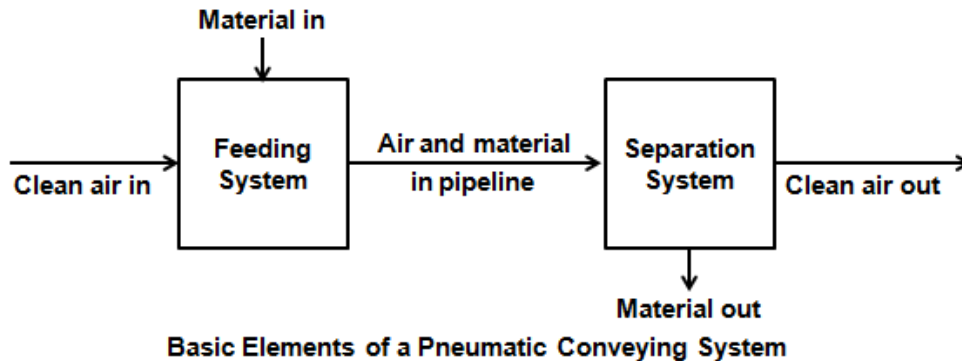

As shown in above figure, all pneumatic conveying systems, whether they are of the positive or negative pressure type mainly consist of a feeding system and a separation system. The system requires gas, usually air to convey materials. For hygroscopic materials, dry air can be used and for potentially explosive materials, an inert gas such as nitrogen can be employed. Information on fundamentals for conveying material pneumatically is given in this chapter.

Pneumatic Conveying Regimes and Design Considerations

If the material is conveyed in suspension in the air through the pipeline it is referred to as dilute phase conveying. If the material is conveyed at low velocity in a non-suspension mode, through all or part of the pipeline, it is referred to as dense phase conveying.

Dilute Phase Conveying

Almost any material can be conveyed in a dilute phase through a pipeline regardless of the particle size, shape or density. It is often referred to as suspension flow because the particles are held in suspension in the air as they are blown or sucked through the pipeline. A relatively high velocity is required and so power requirements can also be high but there is virtually no limit to the range of materials that can be conveyed.

There will be contact between the conveyed material and the pipeline, particularly at the bends, and so due consideration must be given to convey friable and abrasive materials.

Dense Phase Conveying

Generally, in a dense phase conveying two modes of flow are used. One is moving bed flow, in which the material is conveyed in dunes on the bottom of the pipeline, or as a pulsatile moving bed, when viewed through a sight glass in a horizontal pipeline. The other mode is slug or plug type flow, in which the material is conveyed as the full bore plugs separated by air gaps.

Moving bed flow is only possible in a conventional conveying system if the material to be conveyed has good air retention characteristics. This type of flow is typically limited to very fine powdered materials having a mean particle size in the range of approximately 40 - 70 μm , depending upon particle size distribution and particle shape.

Plug type flow is only possible in a conventional conveying system if the material has good permeability. This type of flow is typically limited to materials that are essentially mono-sized, since these allow the air to pass readily through the interstices between the particles. Pelletized materials and seeds are ideal materials for this type of flow.

Conveying Air Velocity

For dilute phase conveying a relatively high conveying air velocity must be maintained. This is typically in the region of 12 m/s for a fine powder, to 16 m/s for a fine granular material, and beyond for larger particles and higher density materials. For dense phase conveying, air velocities can be down to 3 m/s, and lower in certain circumstances.

These values of air velocity are all conveying line inlet air velocity values. Air is compressible and so as the material is conveyed along the length of a pipeline the pressure will decrease and the volumetric flow rate will increase.

As per the basic thermodynamic equation, the air parameters along the length of a pipeline can be expressed as under.

$$\frac{P_1 V_1}{T_1} = \frac{P_2 V_2}{T_2}$$

Where P is the air pressure, V is the air flow rate and T is the air temperature (°K) and subscripts 1 and 2 relate to different points along the pipeline.

If the temperature can be considered to be constant along the length of the pipeline, this reduces to:

$$P_1 V_1 = P_2 V_2$$

Thus if the pressure is one bar gauge at the material feed point in a positive pressure conveying system, with discharge to atmospheric pressure, there will be a doubling of the air flow rate, and hence velocity in a single bore pipeline. If the conveying line inlet air velocity was 16 m/s at the start of the pipeline it would be approximately 32 m/s at the outlet. The velocity, therefore, in any single bore pipeline will always be a minimum at the material feed point.

It may be noted that the velocity values are superficial values, in that the presence of the particles is not taken into account in evaluating the velocity, even for dense phase conveying.

Particle Velocity

In dilute phase conveying, with particles in suspension in the air, the mechanism of conveying is one of drag force. The velocity of the particles, therefore, will be lower than that of the conveying air.

In a horizontal pipeline the velocity of the particles will typically be about 80% of that of the air. This is usually expressed in terms of a slip ratio, defined in terms of the velocity of the particles divided by the velocity of the air transporting the particles, and in this case it would be 0.8. In vertically upward flow in a pipeline a typical value of the slip ratio will be about 0.7.

At the point at which the material is fed into the pipeline, the material will essentially have zero velocity. The material will then be accelerated by the conveying air to its slip velocity

value. This process will require a pipeline length of several metres and this distance is referred to as the acceleration length.

There is a pressure drop associated with acceleration of the particles in the air stream and it has to be taken into account. It is not only at the material feed point that there is an acceleration pressure drop. It is likely to occur at all bends in the pipeline. In traversing a bend, the particles will generally make impact with the bend wall and so be retarded. The slip velocity at exit from a bend will be lower than that at inlet and so the particles will have to be re-accelerated back to their steady-state value.

Solids Loading Ratio

Solids loading ratio, or phase density, is a useful parameter in helping to visualize the flow. It is the ratio of the mass flow rate of the material conveyed divided by the mass flow rate of the air used to convey the material.

For dilute phase conveying, maximum values of solids loading ratio that can be achieved are typically of the order of about 15.

For moving bed flows, solids loading ratios need to be a minimum of about 20 before conveying at a velocity lower than that required for dilute phase can be achieved. Solids loading ratios, however, of well over 100 are quite common.

For plug type flow, the materials have to be very permeable. Hence, for plug type flow, maximum values of solids loading ratio are only of the order of about 30, even with high values of conveying line pressure drop.

Conveying Capability

Though pneumatic conveying systems are capable of conveying almost any material; distance, however, does impose a practical limit. As compared to hydraulic conveying systems, capable of conveying material at a flow rate in excess of 100 tonne/h, over a distance of 100 km, or more in a single stage, the limit for pneumatic conveying is typically about 1.5km for most applications.

As water is having a density that is about 800 times greater than that of air, at free air conditions, the difference in density between the conveyed material and that of the conveying fluid is widely different. Due to this, conveying air velocities are about ten times greater than those required for water in order to convey material in suspension.

High Pressure Conveying

As water is incompressible, there is little change in the velocity along the length of the pipeline. Therefore, water pressure up to about 150 bars is used. As air is compressible, very few systems, anywhere in the world, operate at a pressure much above 5 bar gauge when delivering material to a reception point at atmospheric pressure.

In terms of pneumatic conveying, high pressure means anything above 1 bar gauge. This corresponds with a doubling in conveying air velocity, as mentioned above. With any higher air supply pressure, it is recommended that the pipeline should be stepped to a larger bore along its length in order to prevent high values of velocity from occurring.

Apart from problems of high erosive wear and particle degradation, high velocity has an adverse effect on pressure drop. The appropriate relationship being:

$$\Delta p \propto \frac{L \rho C^2}{d}$$

Where Δp is the pressure drop, L , the length of straight pipeline, ρ , the air density, C , the conveying air velocity and d , the pipeline bore.

It can be seen that the pressure drop is proportional to the square of the velocity. Therefore, it is extremely important to keep conveying air velocities to as low a value as possible. In this respect the stepping of a pipeline is generally an advantage, not just in minimizing wear and degradation, but generally in terms of achieving an improvement in conveying performance.

Flow Rate Capability

The capability of a pneumatic conveying system, in terms of achieving a given material flow rate, depends essentially on the conveying line pressure drop available and the diameter of the pipeline. As mentioned above, the use of pressure is generally limited in the majority of applications to about 5 bars and so to achieve the required material flow rate, pipeline bore is increased.

In many cases pressure capability is set by the desire to use a particular type of compressor or blower. In most cases the duty of conveying a given flow rate of material can be met by a wide range of combinations of pressure drop and pipeline bore.

Selection of Pneumatic Conveying Regime

Selecting the correct pneumatic conveying regime for a requirement is a vital decision for a successfully designed (addressing both technical and economic considerations) system.

As stated earlier, almost any material can be conveyed in a dilute phase. However, many materials are naturally capable of being conveyed in dense phase flow at low velocity.

To maximize benefits, a regime providing the heaviest line loading and the lowest material velocity should be selected.

Following figure shows various regimes for pneumatic conveying.

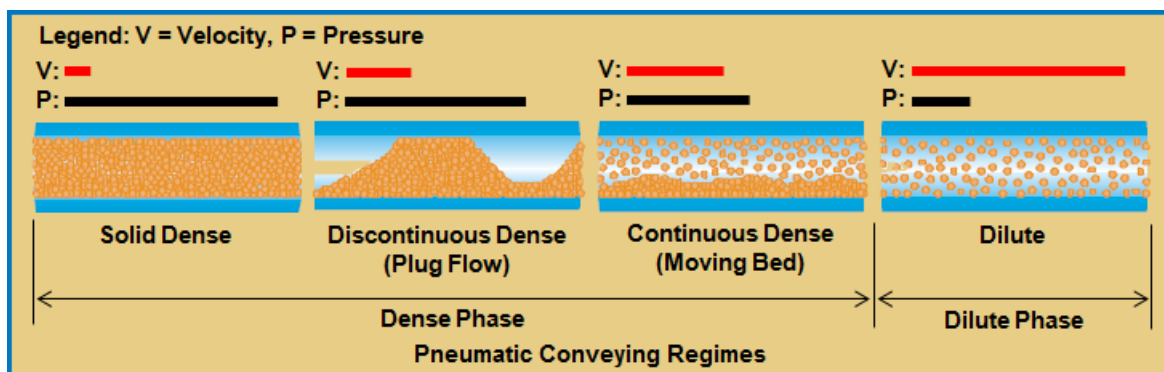

Solid Dense Phase

Very low material velocity – pipeline full of material – an excellent regime for fragile materials.

Discontinuous Dense Phase (Plug Flow)

Low material velocity – pipeline almost full of material which moves in plug flow fashion – best regime for most applications in which power economy, pipe erosion and material degradation issues are important.

Continuous Dense Phase (Moving Bed)

Higher velocity than discontinuous dense phase, but much lower than dilute phase. Used for fluidizable powders.

Dilute Phase

Material velocity above the saltation velocity – no upper limit to the velocity – least attractive regime for operating economy (lower velocity requires lower power to achieve a required capacity) - unsuitable for abrasive materials or materials with wide particle size distribution.

Innovatory Systems

In a conventional system the material is simply fed into a pipeline and it is either blown or sucked to its destination. It must be realized that low velocity, dense phase, conveying in conventional pneumatic conveying systems is strictly limited to materials that have the necessary bulk properties of good air retention or good permeability.

Due to high velocity, dilute phase conveying is not suitable for friable or abrasive material. It also may not be possible to convey these materials in the dense phase mode if they are not having natural bulk characteristics such as good air retention or permeability because dense phase conveying capability is dictated by the properties of the material. In such condition, alternatives to conventional dense phase system may have to be considered.

For a material that is only slightly hygroscopic, successful conveying may be achieved if the material is conveyed in dense phase, without the need for special air drying equipment, since air quantities required for conveying can be significantly lower in dense phase than those for dilute phase. For food products which may be subject to a loss in flavor in contact with air, dense phase conveying needs to be considered. If any such material is not capable of being conveyed in dense phase in conventional systems, alternative systems will have to be considered.

With a need to convey many materials at low velocity, much research and development work has been undertaken to find means of conveying materials, having no natural dense phase conveying capability, at low velocity. The innovatory systems produced as a result of the research and development work has concentrated on some form of conditioning of the conveyed material, either at the feed point into the pipeline or along the length of the pipeline to artificially create either permeability or air retention in the material. Since these modifications are essentially on the pipeline, types of conveying system have not changed significantly.

Many of the innovatory systems are capable of being stopped and re-started during operation. With most conventional systems this is not possible, and would result in considerable inconvenience in clearing pipelines, if it happens.

Innovatory system may also be used because operating cost for power is likely to be lower in dense phase than those for a conventional dilute phase system.

Conveying Short Aerated Plugs

For materials that are impermeable and do not retain air, a short plug will completely block a pipeline. This situation corresponds to mechanically pushing a plug of material for which the pressure required varies exponentially with plug length, as shown in the following figure. Due to this, bulk solids cannot be 'pumped' as a continuous plug over an appreciable distance like a liquid because in such cases the pressures required are prohibitively high. Under such circumstances, the air expanding through the interstices aerates the bulk material so as to reduce the friction between the particles and the pipeline wall.

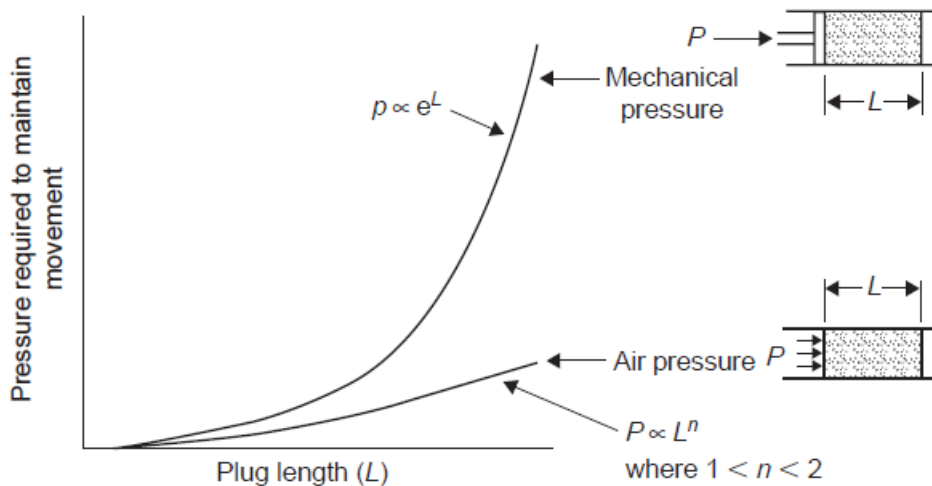

Pressure Required to Maintain Movement of a Plug of Material in a Pipeline

Above figure shows comparison of the pressures required to maintain movement of mechanical and aerated plugs of material in a pipeline. The exact nature of the relationship of the pressure required to move aerated plugs of material is not known but research suggests that it is somewhere between a linear and a square law dependence on the length of the plug, the value depending upon the properties of the material.

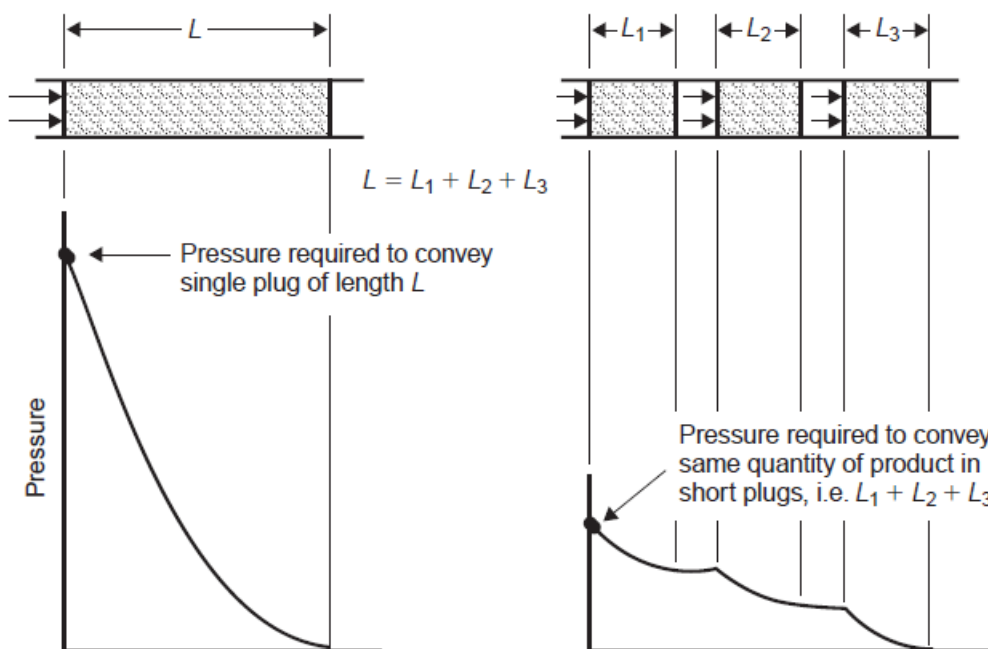

Relationship between Pressure and Plug Length for Continuous and Pulse Phase Conveying

For materials that have a high value of the exponent, n , long distance conveying in this mode requires prohibitively high pressures. However, on account of the non-linear relationship between pressure and plug length, the pressure required to convey a number of short plugs is significantly less than that required to convey a single plug of equivalent length, as shown in above figure. Thus if the material is conveyed as a number of short plugs, separated by air gaps, the pressure requirements can be reduced substantially.

For a given system pressure, by increasing the length of the air cushions, and thereby decreasing the number of plugs in the pipeline, it is possible to convey material over longer distances.

Plug Forming System

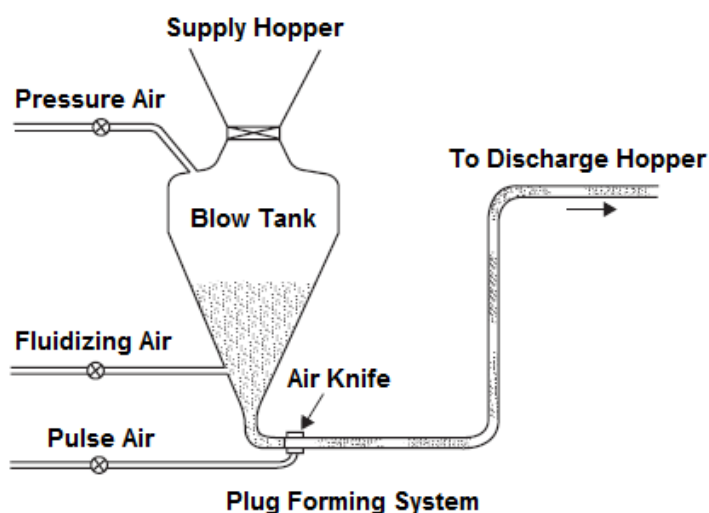

As shown in above figure, in the plug forming systems, pulse air is used to form plugs of material to be conveyed. The system with pulse air was initially developed for the handling of fine materials of a cohesive nature that are difficult to be convey in conventional systems. However, subsequent developments have shown that a wider range of materials can be conveyed successfully.

In this system, pressurized air is supplied to the top of the blow tank to pressurize the system and fluidizing air to aeration rings near the bottom of the blow tank like in a conventional system. In addition to this, pulse air is supplied to the air knife at the start of the conveying line. A timer switches the air to the knife on and off at a pre-determined frequency. When the air supply to the knife is on, the air pulse splits the material in the pipeline, stops the flow of additional material from the blow tank, and pushes the severed plug a short distance along the pipeline. When the air to the knife switches off, the material again flows from the blow tank, past the air knife, and the cycle repeats itself.

By-pass Systems

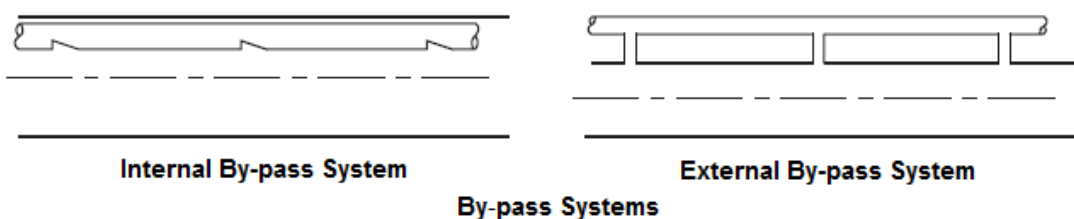

As shown in above figure, there are two types of by-pass systems. The internal by-pass system employs a small pipe running inside the conveying line, having fixed ports, or flutes, at regular intervals along its length. The external by-pass system has the by-pass external to the conveying pipeline and connected to it at intervals along the length. The bore of the by-pass pipe is typically 20–25 % of the bore of the conveying pipeline.

The spacing of the cross-connections to the external pipe or the flutes along the length of the internal pipe depends upon the permeability of the conveyed material. These parallel pipes are not supplied with an external supply of air but air within the conveying line can enter them freely through the openings.

The by-pass pipe may run continuously when external to the pipeline and so include bends, but the internal fluted pipe is generally confined to straight lengths of pipeline only.

Air by-pass systems are generally employed for materials that are impermeable to air and which tend to form solid plugs when conveyed at low velocity. If the material is impermeable, the air will be forced to flow through the by-pass pipe if the conveying pipeline blocks and allow air to be advanced to a point where it is capable of splitting up the plug at the forward end and thus allow conveying to continue. As the by-pass pipe is much smaller in diameter than the conveying pipeline, the air will be forced back into the pipeline through subsequent flutes, and results in breaking-up of the long plug of material causing the blockage. A long plug of material is thus divided into short slugs that are readily conveyed.

Double Tube Socket Conveying Pipe



Double Tube Socket Pipes

Above figure shows double tube socket (DTS) pipes for making an internal by-pass system.

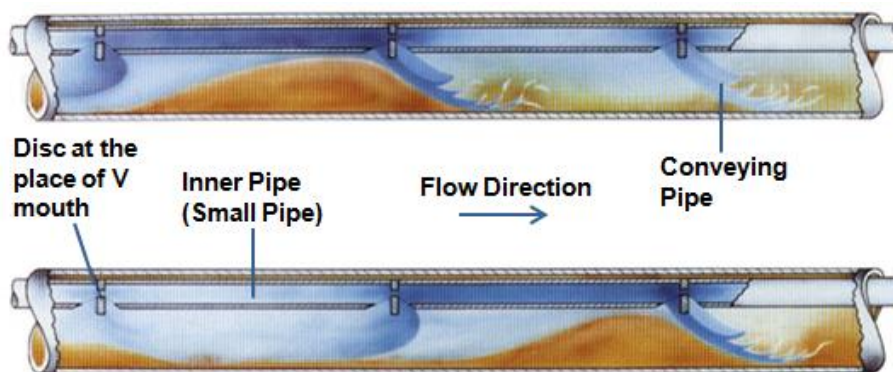

Working of DTS Pipes

As shown in above figure, in this system, a smaller diameter inner pipe is placed inside the conveying pipe, and there are special nozzles designed in the inner pipe at intervals.

In such system, when the material blocks in some place of the conveying pipe, the conveying pressure in front of the material will increase so that the air flow will be induced into the inner pipe, and then will effuse at high speed from another upstream nozzle, which will disturb and blow through such block material to assure continuous material conveying.

Double tube socket (DTS) pipe system is developed by Beijing Guodian Futong Science and Technology Development Co. Ltd., Beijing, China.

Air Injection Systems

In an air inject system air is injected into the pipeline at regular points along its length. While by-pass pipe systems artificially create permeability in the bulk material, air injection helps to maintain a degree of air retention within the material. Like with the by-pass system, in air inject systems also a parallel line runs alongside the conveying pipeline. In air injection systems, however, this parallel line is provided with an independent air supply.

Due to the injection of additional air into the pipeline, the conveying air velocities towards the end of the pipeline will increase. As an increase in velocity will magnify problems of erosive wear and particle degradation, air addition should be kept to a minimum.

There are two types of air inject systems.

Gattys System

Gattys patented 'Trace Air' method can give artificial air retention properties to a material. In this system air at relatively low pressure is supplied continuously to the material in the pipeline through an internal perforated pipe that runs the whole length of the conveying line.

Booster System

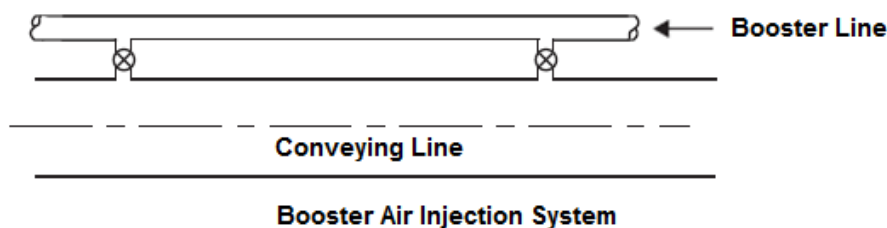

As shown in above figure, in a booster system, a separate supply of air is provided to a line running parallel to the conveying line. Air is injected into the conveying pipeline at regular intervals along its length, typically spaced from 3 to 15 m apart, depending upon the material to be conveyed. In some systems sensors are positioned between the parallel airline and the conveying pipeline so that air is only injected where required. If a change in pressure difference between the two lines is detected, which would indicate that a plug is forming in the conveying pipeline, air is injected at that point to break up the plug and facilitate its movement.

Caution

Wear is accelerated if a pipeline conveyor operates at a loading lower than that for which it is designed. Such reduced loading can be due either to air leakage into the conveyor, slow feed out of the collection hopper, or obstruction in the line. Whenever loading is reduced, the vacuum producer can pull more air. The greater air flow means greater velocity and hence increased wear; wear increases exponentially with velocity.

Some pipeline conveyors are operated continuously to keep the collection hoppers empty. In these cases, the feed of ash into the conveyor is light and the loading is low, with resulting high velocity and wear.

Glossary of Pneumatic Conveying Terms

Acid Dew Point

The temperature at which acid vapor in flue gas condenses into free moisture. The acid dew point is higher than the water dew point.

Aerated

Material that has been subjected to fluidizing.

Air Lock

A multi-chambered device for moving material from one pressure zone to another; for example, from a baghouse at negative pressure to a pipe conveyor at positive pressure.

Air Retention

The ability of a bulk material to retain air in the interstitial spaces between particles for a period of time. Very fine materials such as cement can exhibit this property, and when first poured into a container the material can behave almost like a liquid.

Blow Tank

The principal material transfer mechanism in a dense phase conveying. The blow tank is alternately filled with material and then pressurized, after which the contents are discharged under pressure through the conveyor pipeline.

Booster Sections

Sections of reduced diameter placed in a pipeline conveyor. They are intended to increase velocity at points that are either potentially or actually prone to plugging. The inclusion of booster sections is usually a post installation fix.

Choking

Choking occurs in vertically upward flow and is the process that commences when solid particles near the pipe wall begin to flow downwards. As the process continues the pipeline eventually becomes blocked or chokes.

Note: Choking in vertical transport is somewhat analogous to saltation in horizontal transport, for both phenomena represent the onset of saturation conditions in dilute phase flow.

Conveying Line Inlet Air Velocity

This is the superficial air velocity at the point where the material is fed into the pipeline.

Note: In a single bore pipeline this will be the lowest air velocity in the conveying line and so it must be greater than the minimum conveying air velocity required to ensure successful conveying of a material. This is also referred to as the pick-up or entrainment velocity. In a vacuum conveying system it is approximately equal to the free air velocity.

Conveying Line Exit Air Velocity

This is the superficial air velocity at the end of a conveying line where the material is discharged into the receiving vessel.

Note: In a single bore pipeline this will be the highest air velocity in the conveying line. In a positive pressure conveying system, it is approximately equal to the free air velocity.

Dense Phase Conveying

Dense phase conveying occurs when materials are conveyed with air velocities lower than those required for dilute phase over all or part of the pipeline.

Dilute Phase Conveying

Dilute phase conveying occurs when a material is conveyed in suspension in the flowing air. The dilute phase mode of conveying is sometimes referred to as lean phase or suspension flow.

To keep the material in suspension in the pipeline it is necessary to maintain a minimum value of conveying line inlet air velocity. The conveying line inlet air velocity for most materials is of the order of 13 to 15 m/s.

Exhauster

Device for introducing air flow into a pneumatic vacuum conveyor. May be either a rotary mechanical device or a venturi type powered by air, water or steam.

Fluidizer

A porous element arranged so that ash (granular material) is on one side of the element and low pressure air is applied to the other. The air permeating through the element raises and separates the ash particles, and provides a curtain of air around them. This reduced interparticle friction and thus shear strength, which allows the ash to flow more readily. Fluidizers are used in precipitator hoppers, ash feeders, silo bottoms, and other equipment.

Fluidizing

The action produced by fluidizers as described above.

Free Air Conditions

Free air conditions are specified as those at which pressure = 101.3 kN/m² absolute (standard atmospheric pressure) and temperature = 15°C (standard atmospheric temperature).

Note: Free air conditions are generally used as the reference conditions for the specification of blowers and compressors.

Free Air Velocity

This is the superficial velocity of the air when evaluated at free air conditions.

Gates

The preferred term for valves used in pneumatic pipeline conveyors. They are available in various configurations, including butterfly, slide, swing disc, dome, etc.

Loading

Expression for the concentration of particulate matter in a pipeline conveyor. Units for pneumatic conveyors are kilograms/pounds of ash per kilogram/pound of air. For hydraulic conveyor, loading is expressed as weight percent; e.g., 15% solids by weight.

Minimum Conveying Air Velocity

The minimum conveying air velocity is the lowest superficial air velocity that can be used to convey a material.

Note: Most data for minimum conveying air velocity are generally determined experimentally or from operating experience. In dilute phase flow this is the lowest air velocity that can be achieved without saltation or choking occurring. Some investigators have recommended the use of a velocity 2 to 2.5 times the saltation velocity. The literature often recommends a velocity 20 percent above the saltation velocity as a minimum. The value of the minimum conveying air velocity in dense phase flow is significantly influenced by the solids loading ratio of the conveyed material, in the case of materials having good air retention properties.

Mohs' Scale

The Mohs' scale of hardness is based on the ability of each material to scratch ones that come before it on the scale. Each material is allocated a number, 1 for the least hard material through to 10 for the hardest material. These are talc 1, gypsum 2, calcite 3, fluorite 4, apatite 5, feldspar 6, quartz 7, topaz 8, corundum 9 and diamond 10.

Permeability

This is a measure of the ease with which air will pass through a bed of bulk particulate material when a pressure difference is applied.

Note: Pelletized materials generally have very good permeability for there is little resistance to the flow of air through the interstitial passages. Materials that have a very wide particle size distribution generally have very poor permeability. If a pipeline blockage occurs with such a material a small plug of the material is often capable of holding an upstream pressure of 5 bars for a period of several minutes.

Pickup Velocity

The point of increasing air velocity through a conveyor pipe at which material deposited on the bottom of the pipe is substantially entrained into the air stream.

Pneumatic Conveying

The transport of solids through a pipeline in a moving mass of compressible fluid, usually air or flue gas.

Saltation

Saltation is the process of deposition of solid particles along a horizontal pipeline.

Note: This phenomenon occurs in dilute phase flow when the air velocity falls below the minimum conveying value. The **saltation velocity** is the minimum velocity at which a dilute phase system will operate and is equivalent to the minimum conveying air velocity.

Solids Loading Ratio

Solids loading ratio is the ratio of the mass flow rate of the material conveyed to the mass flow rate of the air used for its conveying.

Stepped Pipeline

A continuous pipeline in which the diameter of the conveying pipe changes to a larger bore, at points along its length. The purpose is to accommodate the change in volumetric flow rate of the conveying air as the pressure changes, without the velocity falling below the minimum value of conveying air velocity at any point.

Superficial Air Velocity

This is the velocity of the air disregarding the presence of the solid particles or porous media.

Note: In a pipeline it is the air velocity based upon the cross-sectional area and neglecting the space occupied by the conveyed material. For flow across a membrane or filter it is the open duct velocity normal to the surface.

Transient

A temporary continuous changing rate of flow caused by non-steady state flow conditions, such as starting up and shutting down conveying systems, particularly where blow tanks are employed.

Vacuum Breaker

Vacuum relief valve used on pneumatic pipeline conveyors to interrupt the vacuum, allowing receiving equipment to dump accumulated ash.

Valley Angle

The angle formed with the horizontal of two adjacent sides of a pyramidal ash storage hopper.

Fly Ash Handling

Information about various types of pneumatic conveying systems used for fly ash handling is given in the chapter.

Negative-Pressure Dilute-Phase System (Vacuum System)

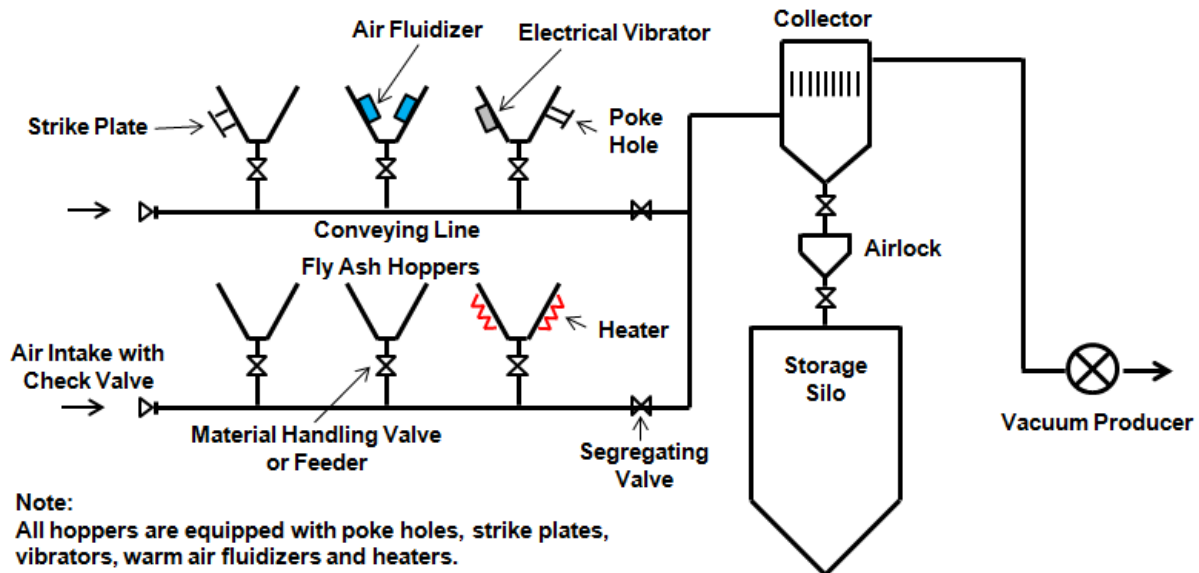

Schematic Diagram of Vacuum Conveying System

In a negative-pressure dilute-phase system (vacuum system), a vacuum pump (mechanical exhauster) or steam exhauster or water exhauster is used to create a vacuum. The vacuum pulls ash conveying air through the air intake at the end of the conveying line. The hopper valves open automatically in sequence allowing fly ash to fall into the air stream. The mixture of air and fly ash is conveyed to the collector on top of the storage silo. A deflector plate and filter in the collector separates fly ash from the mixture and air flows to the vacuum producer. Fly ash accumulates in the collector hopper and falls into the storage silo through airlock vessel. The valve on top of the airlock isolates the silo from the collector. When the airlock vessel fills, the top valve closes and the bottom valve opens to empty the airlock vessel into the silo. In systems using water exhausters, the fly ash is sometimes mixed with the water and sluiced to the disposal location.

After vacuum is established in the conveying line, hopper valves are opened in a preselected sequence. Fly ash is pulled into the conveying line (system piping) and proceeds to the collector. Normally, one hopper is emptied at a time. A hopper is considered empty when vacuum in the conveying line falls. When this low vacuum condition exists, the hopper valve closes automatically and the next hopper valve opens.

Under smooth ash flow conditions, the system functions very efficiently. However, when the ash is sticky, or clinkers are formed, or the ash for any reason sticks to the hopper walls, a "rat-holing" effect is often encountered and the ash is not getting emptied. The presence of a hopper high level alarm, while not solving this problem, alerts the operator to an adverse situation requiring unusual hopper evacuation procedures.

The pressures in these systems range from -20 in Hg (510 mm Hg) to atmospheric at the air intake point.

Within the limits of conveying capacities and distances, vacuum system typically provides the lowest initial cost for a fly ash system. A vacuum system is a popular choice for conveying fly ash as several inherent features make it an advantageous design. They are:

- Simple ash intake valves.
- Conveyor feed sensing that provides positive ash feed control.
- Low headroom requirement.
- Clean operation, because any joint leakage will be into the conveyor.

However, conveying distance and capacity requirements sometimes limit the use of a vacuum system. The alternative is generally a pressure system, or a combination of vacuum and pressure system.

Conveying capacities are generally limited to 50 tons per hour (55 Metric Ton per hour) and conveying distances less than 1000 ft (305 m).

To separate ash from the mixture of air and ash more efficiently, instead of collector with a deflector plate and filter, many times a centrifugal receiver and a pulse jet bag type dust collector are installed on the storage silo.

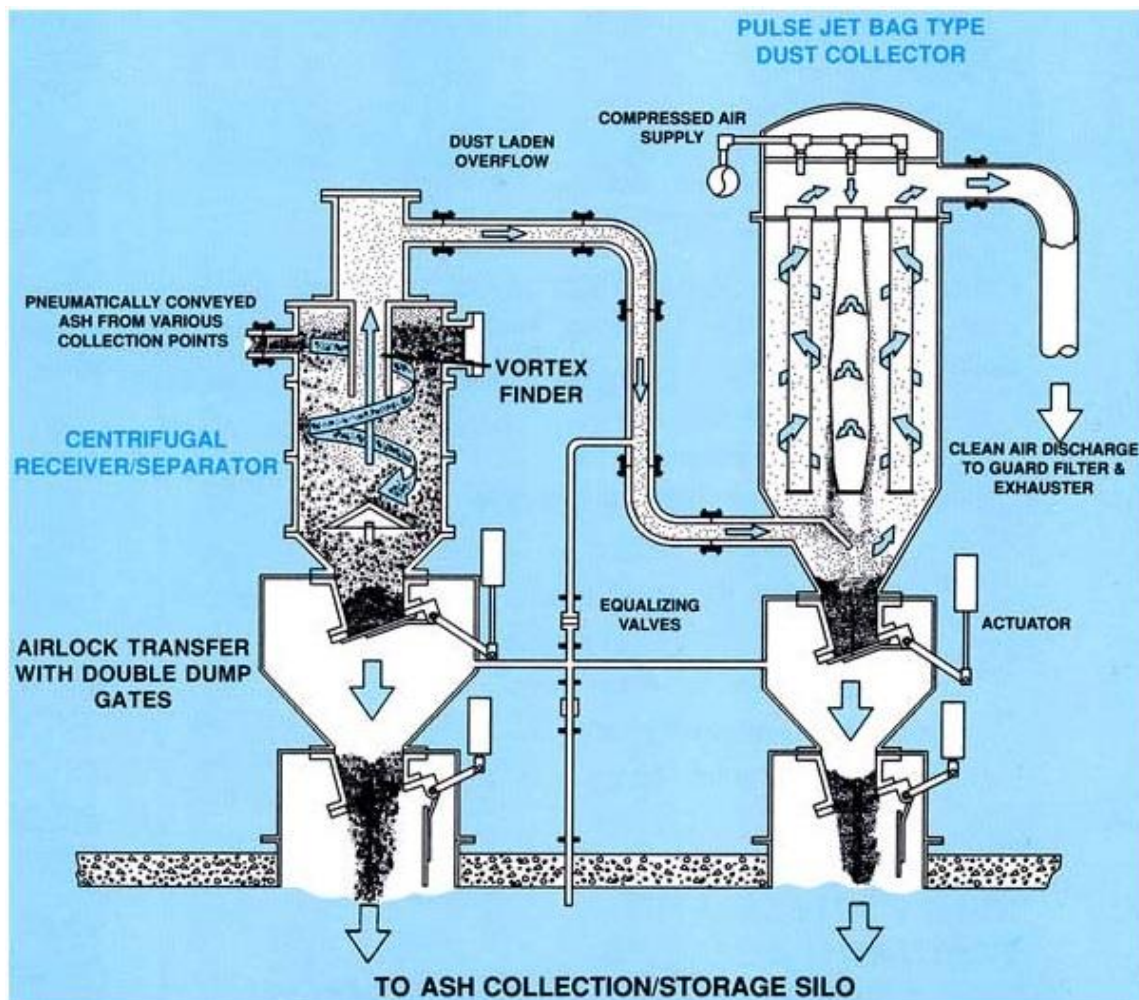

Centrifugal Receiver and Pulse Jet Bag Type Dust Collector on Storage Silo

As shown in above figure, in this type of arrangement, coarser ash particulates collecting at the bottom of the centrifugal receiver are transferred to the storage silo via a double dump

gate airlock assembly. Finer ash particles and the induced conveying air flow through the "vortex finder" pipe at the top of the centrifugal receiver to a pulse jet bag type dust collector located nearby. Ash particulates released by periodic blow down of the bags collect below, where this material is transferred to the storage silo via a double dump gate air lock assembly. Overall solids recovery in this type of arrangement typically exceeds 99.9% for 2 micron and larger particulates.

Piping

All joints, fittings, and expansion joints are gasketed with suitable material for the temperature and service. To take care of cyclical heating and cooling of lines, expansion joints are generally required in every straight run of pipe.

Pipe in vacuum systems is generally abrasion-resistant cast iron or carbon steel, particularly for long, straight systems. Fittings are chromium cast iron with cast in or removable, replaceable, thick-wearback sections (as shown in the following figure). Hand-hole access covers are often provided on the inside radius of elbows or near them to allow removal of foreign objects or blockages. Chromium cast-iron pipe is usually used for a short distance after changes in direction to better protect it against the abrasion from turbulence downstream of fittings.

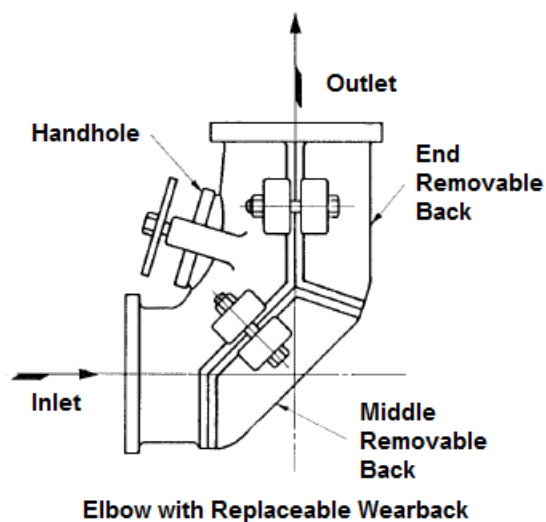

In any pneumatic system, velocity must be carefully controlled while maintaining design capacity, and so the selection of pipe size is of great importance. Transitions to larger pipe must be located to keep ash velocities above the pickup velocity and below the velocity at which severe sandblasting abrasion results. The calculations for the pipe size and location of transitions are partly empirical and considered proprietary by the manufacturers of conveying systems. Generally, the minimum velocity in fly ash conveyor lines should be 3800 ft/min (19 m/s), as extensive testing of a wide range of ashes has shown this to be the usual minimum pickup velocity. In the event that a system is shut down in emergency and ash falls out in the conveyor line, this minimum velocity ensures it will be picked up and conveyed when the system is restarted. Bed ash from fluidized-bed combustors varies considerably, but typically requires at least 4500 ft/min (23 m/s). Bottom ash, if pneumatically conveyed, may require 5000 ft/min (25.4 m/s) or more. Maximum velocities should be minimized, as previously explained, but should not exceed 6500 ft/min (33 m/s) to avoid elbow impact damage and severe erosion of pipe material.

Branch-line and crossover valves/gates are generally automatic and are either knife gates designed for abrasive ash service or totally enclosed rotary slide gates. In both cases, the

inside diameter of the pipe should be maintained through the valve with minimal interference which could cause turbulence and wear.

Positive-Pressure Dilute-Phase System

As shown in the following figure, in positive-pressure dilute-phase ash handling systems, a positive displacement blower is used to generate the ash conveying air flow through the pipeline. Ash is admitted into the conveyor through airlock devices (**rotary airlock feeder** or **double dump gate airlock valves** or **airlock and valves**), which bring the ash up to the pressure of the conveyor. Without the airlock, ash conveying air flow would blow into the ash hopper. At the end of the ash conveying pipeline, ash is received in a highly abrasion resistant silo mounted target box from which it falls by gravity into the storage silo. Ash conveying air is normally exhausted to the atmosphere through a silo vent filter.

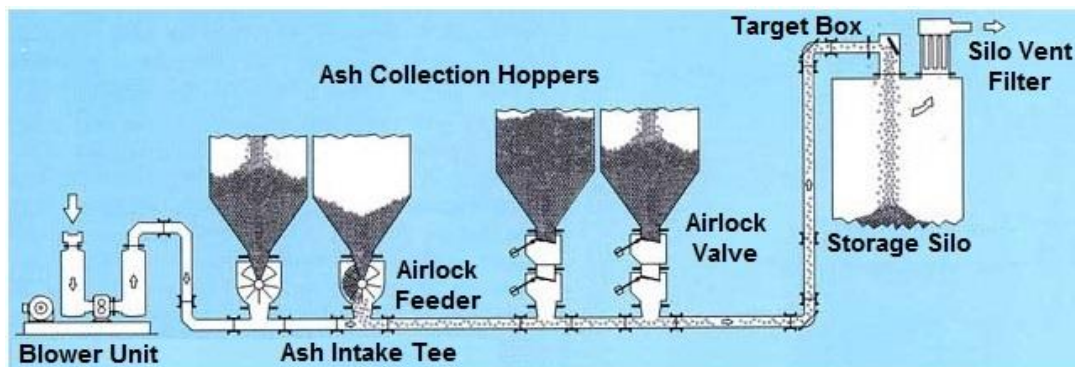

Positive-Pressure Dilute-Phase Ash Handling System

Control of a positive-pressure system is similar to that for a vacuum system. A preset sequence of hopper evacuation is followed, with cycling from hopper to hopper. Whereas a vacuum system determines an empty hopper by low vacuum, a positive-pressure system determines it by low pressure.

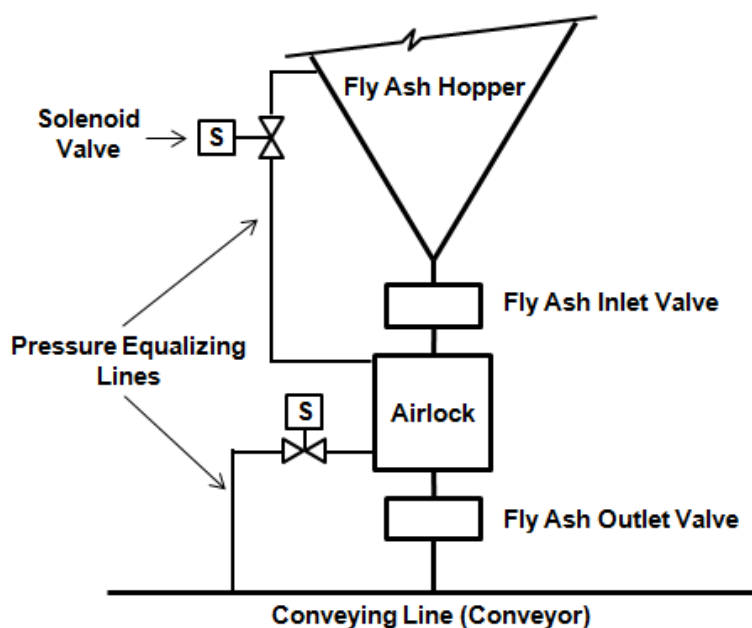

Schematic of Airlock for Pressurized System

The airlock is a device primarily used for the transfer, by gravity, of fly ash or other dry, free-flowing, granular solids from one pressure zone to another. As shown in above figure, using **airlock and valves**, transfer of fly ash from the fly ash hopper to the conveyor in a pressurized system is accomplished as follows.

- Upper valve/gate (fly ash inlet valve) of airlock (vessel) opens.
- Solenoid valve of pressure equalizing line from airlock to fly ash hopper opens.
- Ash flows from fly ash hopper to airlock.
- Upper airlock valve closes after airlock level switch is activated or preset time elapses.
- Solenoid valve of pressure equalizing line to fly ash hopper closes.
- Lower valve (fly ash outlet valve) of airlock opens.
- Solenoid valve of pressure equalizing line from conveying line to airlock opens.
- Ash flows to conveying line and is transported to silo.
- Lower valve of airlock closes.
- Solenoid valve of pressure equalizing line to conveying line closes.

Above sequence is considerably simplified and may vary depending upon equipment manufacturer however, the basic principle remains the same.

Access door is provided in the fly ash inlet and outlet valve chambers for ease of maintenance and inspection. The Ni-Hard gate and seat of these valves are replaceable. These valves are operated by air cylinder actuators. These valves are interlocked so that only one valve is permitted to open at a time.

As a general guideline, pressure systems are used when required capacities exceed 50 tons per hour (55 Metric Ton per hour) or conveying lengths exceed 1000 ft (305 m). Pressures are typically less than 35 psig (240 kPa) at the blower discharge.

Construction of the conveyor line is similar to that in vacuum systems, except that integral wearback fittings are used as shown in the following figure to minimize the amount of potential leak sites (gasketed area).

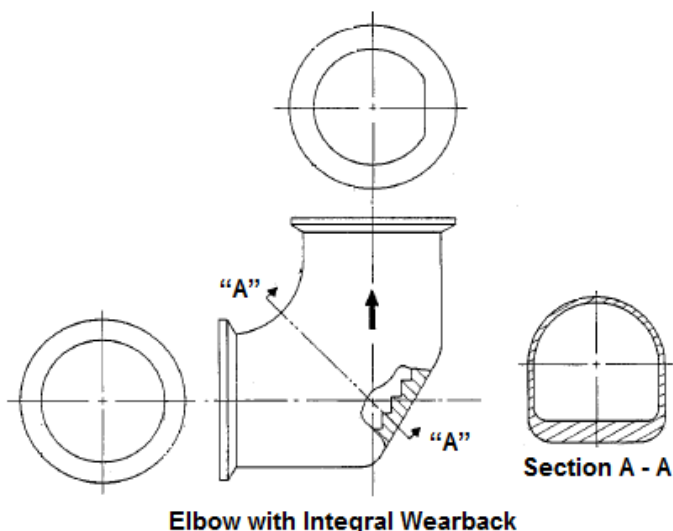

Combination of Vacuum and Pressure Dilute-Phase System

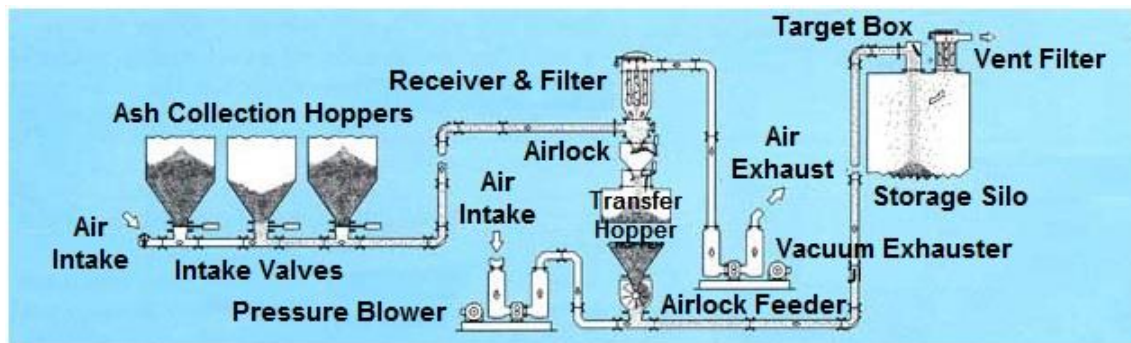

Combination of Vacuum and Pressure Dilute-Phase Ash Conveying System

As shown in above figure, combination of vacuum and pressure dilute-phase ash conveying systems can be beneficially applied to take advantage of the simplicity of a vacuum system for the collection and delivery of ash to a transfer hopper from which it is reclaimed through an air lock feeding device for pressurized conveyance to a remote location silo.

Positive-Pressure Dense-Phase System

Positive pressure dense phase pneumatic conveying is ideal for transfer of abrasive, friable, or mixed-batch materials. Use of reduced rate of air to convey these materials make the process gentler. The system is used for conveying distance up to 1500 meters.

Dense-phase pneumatic systems use compressed air to push material along the conveyor line. In general, pressures are higher than those in dilute phase, but velocities are much lower. Generally, material is collected in a pressure vessel, which is sealed and pressurized to commence conveying. A discharge valve is opened, and the slug of material travels along the conveyor line. Often, additional air must be admitted to complete conveying to the discharge location.

Typically, dense-phase system uses NPS 2 to 8 (DN 50 to 200) carbon steel pipes. Cast iron may be used for the NPS 4 (DN 100) and larger systems. Pressures at the pressure vessel may reach 60 psig (414 kPa). For carbon-steel piping, fittings and pipe may be welded, with periodic bolted flanges for access to pluggages.

A dense-phase system is very popular for conveying fly ash due to following advantages.

- Due to high material to air ratio, large quantities can be transported for long distances with less air. Less air requires filter of smaller size.
- Lower power consumption compared to other methods.
- Due to dense phase, smaller transport pipes are required. The resulting structure is also lighter.
- Lower velocity results in less wear. Use of carbon steel pipes.

Air-assisted/Fluidized Gravity Conveyors

The air-assisted gravity conveyors are used in situations where the flow of material can be downwards. Though they require downward incline, the required inclination is only 3 - 12°.

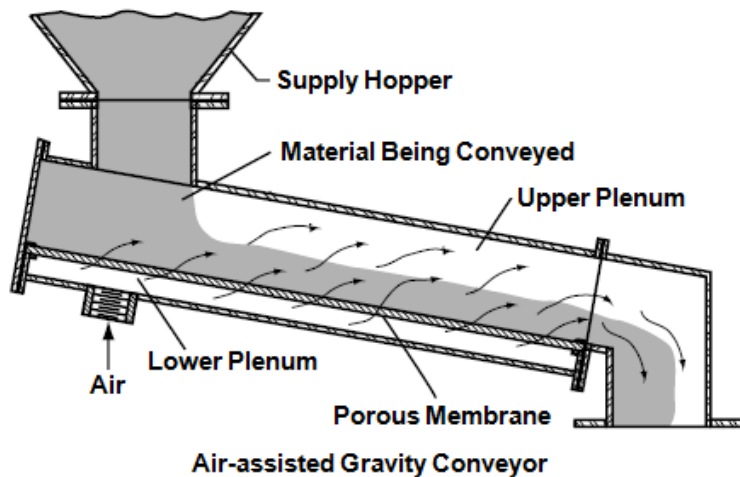

As shown in above figure, the conveyor consists essentially of a channel, divided longitudinally into upper plenum and lower plenum by means of a suitable porous membrane on which the material is conveyed. If a small quantity of low pressure air is fed through the membrane, the material will get fluidized. The inter-particle and particle to wall contact forces will be reduced and the material will behave like a liquid. If a slight slope is imparted to the conveyor, the material flows. The main driving force in these conveyors is gravity.

These conveyors are often referred to as 'air slides'. The two main advantages in favor of air-assisted gravity conveyors are capital cost and operating cost. Plant capital costs can be much lower if air-assisted gravity conveyor system is installed instead of pneumatic conveying system. The operating cost also will be significantly lower due to lower power consumption.

Air-gravity conveyors, ranging in width from 100 to 600 mm, can convey materials over distances of up to 100 m, and are suitable for material flow rates of up to about 3000 tonne/h. In general, most materials in the mean particle size and density ranges from 40 to 500 μm and 1400 to 5000 kg/m^3 , respectively, are the easiest to convey and will flow very well down shallow slopes.



Air-assisted Gravity Conveyors below ESP

As shown in above figure, the air-assisted gravity conveyors are used to convey fly ash from ESP hoppers to an intermediate storage vessel. From this vessel, the fly ash is conveyed to fly ash storage silo using a dilute/dense phase pneumatic conveying system.

Economizer Ash Handling

Handling of economizer ash requires a specific description because it produces a separate set of ash handling problems. Information about its handling is given in this section.

Because the ash is collected close to the furnace, it is very hot and may still be smoldering. It is also the coarsest material collected except for bottom ash, which is heavy enough to fall to the bottom of the boiler.

If this coarse and smoldering ash contain high percentage of carbon, it will sinter and form larger lumps in the economizer hoppers. This makes unassisted removal of this ash by the system difficult if not impossible.

If the ash is not removed from the hoppers, it builds up and effectively blanks them off. If load is reduced, gas-stream velocity also decreases and more material falls out in the ductwork. This effectively reduces the duct cross-sectional area. Whenever the load is increased, the gas flow also increases and this greater flow must pass through a reduced duct area. This increases the load on the I.D. fans.

In view of above, almost all concerned agree that the answer to problems with economizer ash is continuous removal, so that the ash does not clinker and sinter while it is stored in the high temperature environment of the economizer hoppers.

Cinder Feeder

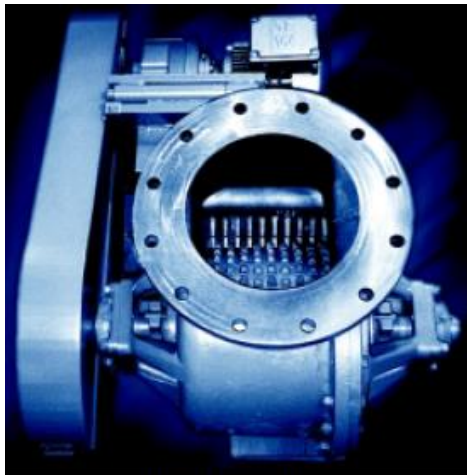

Cinder Feeder

To size economizer ash for proper pneumatic conveying, Cinder Feeder manufactured by Allen-Sherman-Hoff® may be installed at the outlet of the economizer hopper.

In a Cinder Feeder, larger pieces are crushed to approximately 1/4" diameter between a rotating rotor and a stationary breaker bar. Higher throughput capacity is assured by arrangement that allows smaller pieces to pass freely through slots in the feeder's breaker bar. As shown in above figure, Cinder Feeder assembly features a cast iron body with an independent gear motor connected to a roller chain drive. The rotor and breaker bar are heat-treated to surface hardness of 400 Brinell for extended service life. The shaft is supported by externally mounted bearings allowing for temperatures of up to 700°F. Packing rings are used to seal the area where the shaft passes through the cinder feeder.

Water Impound Tanks

This system addresses the problem of continuous removal by placing water impound tank(s) beneath the economizer hoppers. The tank(s) receives the ash as it is collected, keeping the hoppers clear. The hot ash is quenched in the tank and cannot sinter. Periodically, either on a timed cycle or full-tank signal, the impounded ash and water is drained, either to the bottom ash hopper or the pyrites transfer tank.

One problem experienced with water impound tanks is that when hot ash falls into the water, it creates water vapor that goes into the economizer and ducting. At some point in the ducting, perhaps in the precipitator or baghouse, this moisture is condensed and can cause problems.

Another problem is finding space for the tanks in the normally congested area beneath the boiler.

Screw Conveyor

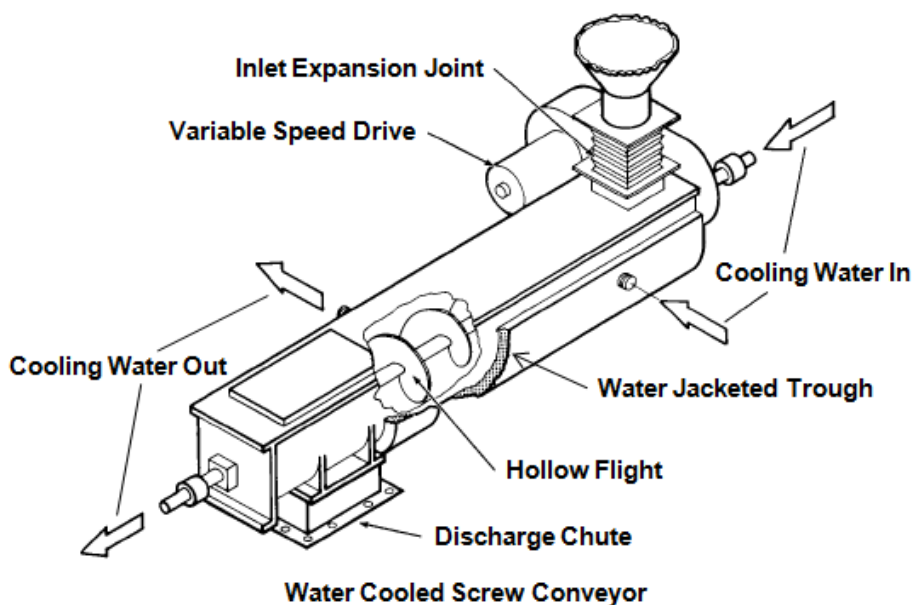

The ash could be removed on a continuous basis from the collection hoppers with a water cooled screw conveyor. The screw conveyor cools the ash and moves it into a holding tank located at the end of the screw (and beside the economizer). The cooled ash cannot sinter, and can be periodically removed by a branch of the pneumatic conveyor that serves the other fly ash collection points.

The screw conveyor should have multiple inlets, one for each economizer hopper. The connections should be flexible because the hopper outlets experience thermal movement in all three planes. For optimum cooling, the conveyor should have a variable-speed drive.

Macawber's Products for Pneumatic Conveying

In selecting the optimum pneumatic conveying system for a given application, first requirement is the selection of a regime to transport a material which depends on characteristics of the material. The next requirement is the selection of a product/system best suitable for the combined requirements of conveying capacity and conveying distance. Various products/systems are available in the market for different materials and conveying requirements. Most of the manufacturers are marketing their products/systems under their trade names. For example, United Conveyor Corporation is marketing their systems as: NUVEYOR Systems, NUVA FEEDER Systems, DAC Systems and MultiDAC Systems.

Macawber is a leading company in the field of pneumatic conveying systems. They provide products, engineering and maintenance services for pneumatic conveying of abrasive or fragile materials such as ash, sand, cement, food, chemicals and more. They provide 8 different products (Technology Groups) for various applications. Following figure shows their products and conveying regime.

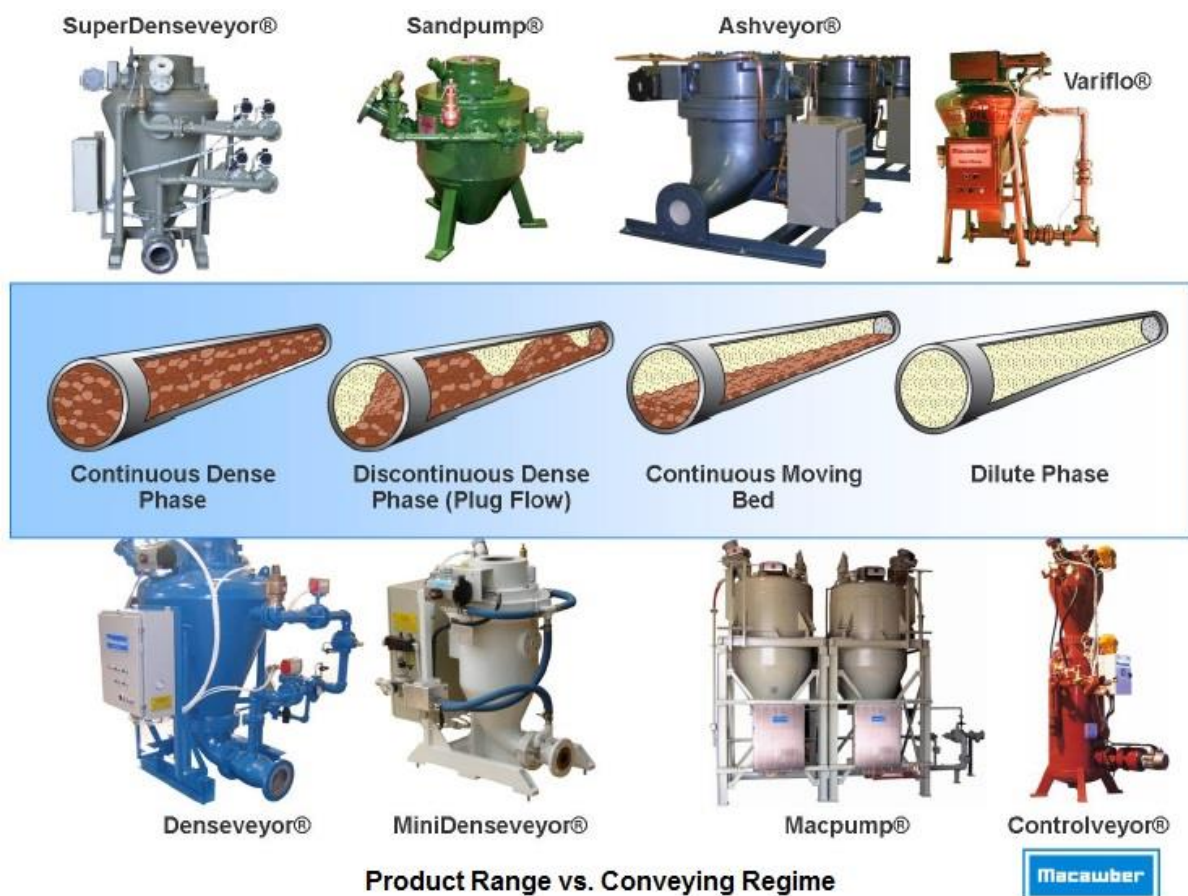

As shown in above figure, they recommended use of Ashveyor® to convey ash (continuous moving bed), whereas sandpump® to convey sand (discontinuous dense phase).

Following figure shows construction of ash vessel used in Ashveyor® technology.

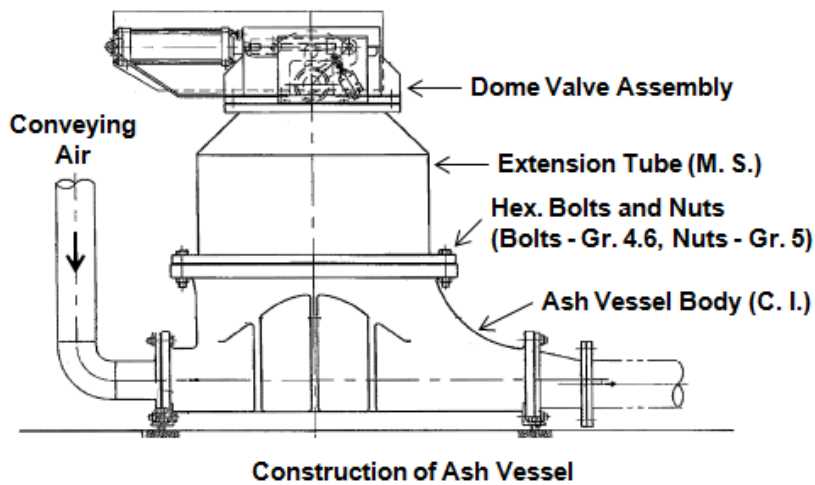

Following figure shows typical installation with Macawber's Ashveyor® technology.



Typical Installation with Macawber's Ashveyor® System

The following table compares Ashveyor® technology with the traditional (old) technologies of positive pressure dilute-phase conveying and vacuum dilute-phase conveying. The example is for a typical conveying distance of 100 m (330 ft.).

Characteristic	Positive Pressure Dilute Phase	Vacuum Dilute Phase	Dense Phase ASHVEYOR®
Material-to-air Ratio	13	8	90
Average Material Velocity	18 m/s (60 f/s)	20 m/s (65 f/s)	4 m/s (13 f/s)
Energy Consumption (kw per ton conveyed)	110 kw	135 kw	75 kw
Pipe Wear	High	High	Low
ESP Hoppers Always Empty	No	No	Yes
Pipeline Material	Schedule 80 carbon steel or chrome cast iron	Chrome cast iron	Schedule 40 carbon steel

Comparison of Ashveyor® System and Old Style Dense-Phase Systems

The typical old style dense-phase systems comprise large vessels with complex pipeline arrangements involving tee connections and discharge valves. The Ashveyor® system of Macawber shown in the following figure is compact, easy to install, and uses a single in-line pipeline arrangement that eliminates tee connections and discharge valves. In addition, the Ashveyor® system does not require level probes, vent valves or air inlet valves to each vessel.

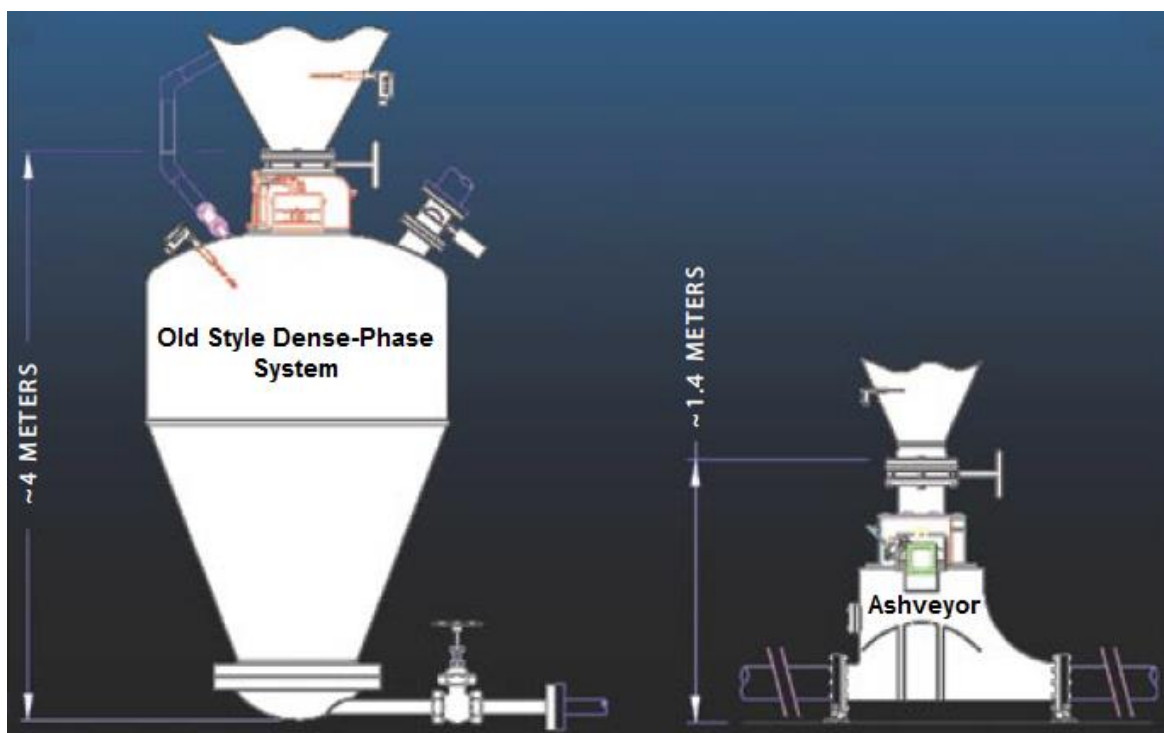

Comparison of Ashveyor® System and Old Style Dense-Phase Systems

For more information on Macawber products and services, please see website of Macawber: www.macawber.com

Piping and Fittings for Handling Bulk Materials

There are no specific codes and standards that apply to ash conveyor piping components. Most of the major manufacturers of ash-handling systems have their own proprietary materials for ash conveyors with pipe sizes and materials, fittings, expansion joints, and specialty devices which are not readily interchangeable from one manufacturer to another. In view of this, information on piping components mostly based on products offered by Allen-Sherman-Hoff® Company (ASH) and United Conveyor Corporation (UCC) is given in this chapter.

Routing

The arrangement of the pipe line (conveyor) from the ash pickup locations to the disposal point should be as direct and simple as possible. Every elbow adds significant pressure drop, which impacts the sizing of the prime mover. Elbows are high-wear points. Like any fitting, they are also potential leak points. While leaking pressure in pneumatic and hydraulic systems will simply cause housekeeping problems, vacuum pneumatic systems are particularly sensitive to leaks which bleed air into the conveyor and dilute the airflow, causing lower velocity leading to reduced conveying capacity, ash fallout and line pluggage.

Routing in the vicinity of the ash pickup points should be as straight as possible to allow the ash time to reach conveying velocity before encountering changes in direction. This will minimize fallout and pluggage problems as well.

Pipes

Generally, centrifugally cast, heavy wall gray cast iron pipe is utilized on long, straight runs for pneumatic systems. The centrifugal casting process provides uniform wall thickness and mass density. It eliminates blow holes, slag and sand inclusions. The result is a high quality product. This pipe is usually plain end that connect with sleeve couplings and is supplied in 18 ft (5486 mm) lengths. Variations include longer lengths or mechanical (flanged, raised beveled or bell-and-spigot) joints. Bell-and-spigot joints are primarily used for sluice lines. These pipes are sold under such trade names as Nuvaloy® (UCC: United Conveyor Corporation) and Ashcolite® (A-S-H: Allen-Sherman-Hoff®, a Diamond Power International, Inc. Division).

Nuvaloy® pipes are available in two hardness grades as under.

NUVALOY I: 285 - 400 BHN
NUVALOY II: 475 - 550 BHN

ASHCOLITE® pipes are also available in two hardness grades as under.

ASHCOLITE®: 280-340 BHN
ASHCOLITE® B: 475-550 BHN

To cut the pipe in the field, the following methods are recommended:

- Power hacksaw operated at low speed
- Wheel saw with an abrasive blade
- Grinding wheel

With a well-designed and well-executed support and anchoring system, plain end pipe can be as satisfactory as beveled end pipe, but the emphasis on well-designed and well-executed supports and anchors must be met.

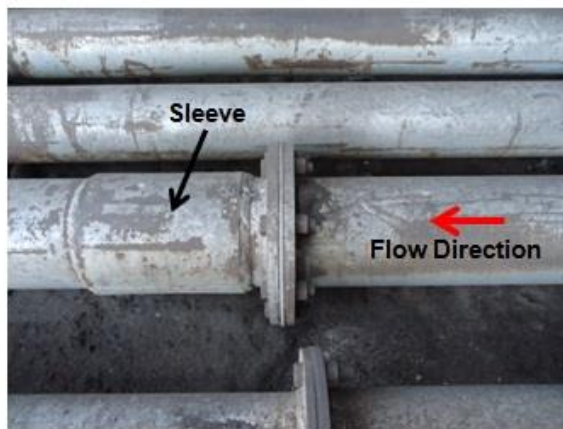

Sleeve on straight Run of Pipe after Flange Joint

Carbon steel pipe (MS ERW conforming to IS: 1239 or IS: 3589), usually schedule 80 is also commonly used to pneumatically convey fly ash because long, straight runs properly sized for velocity convey the ash primarily in the center of the pipe, resulting in little wear. A section of cast pipe approximately 10 pipe diameters long is always provided after a change in direction, as the turbulence after the fitting causes more abrasion. To take care of more wear due to turbulence after a joint, as shown in above figure, many times a sleeve (wear back pipe) is welded on a straight run of pipe after a flange joint.

As shown in the following figure, sometimes instead of a sleeve, a wear back plate is also provided.

Sometimes pipe of chromium cast iron alloys is also used in pneumatic and hydraulic ash conveying systems. Since this pipe is not centrifugally cast, it is provided in shorter sections, 6" to 6' (nominal) depending on diameter. This pipe usually has beveled end that is connect with mechanical joint design. These pipes are sold by UCC under trade name Durite. Durite is available in two hardness grades as under.

Durite C: 400 BHN (Minimum)

Durite H: 600 BHN (Minimum)

Basalt lined (Hardness = 8 Mhos) steel pipe is often used for bottom ash sluice systems where long life is demanded. Basalt is an igneous rock mined commercially in Europe and cast into annular sections assembled into carbon steel shells. DUR-ROK® is a UCC registered trademark for Basalt lined pipes. Following two Indian companies also supply Basalt lined pipes.

DeMech: www.demetchindia.com

DC Industrial Plant Services Private Limited: www.dcips.com

Note: DCIPS manufactures Basalt lined pipe fittings with technology and critical components from Kalenborn Kalprotect, Germany (website: www.kalenborn.com).

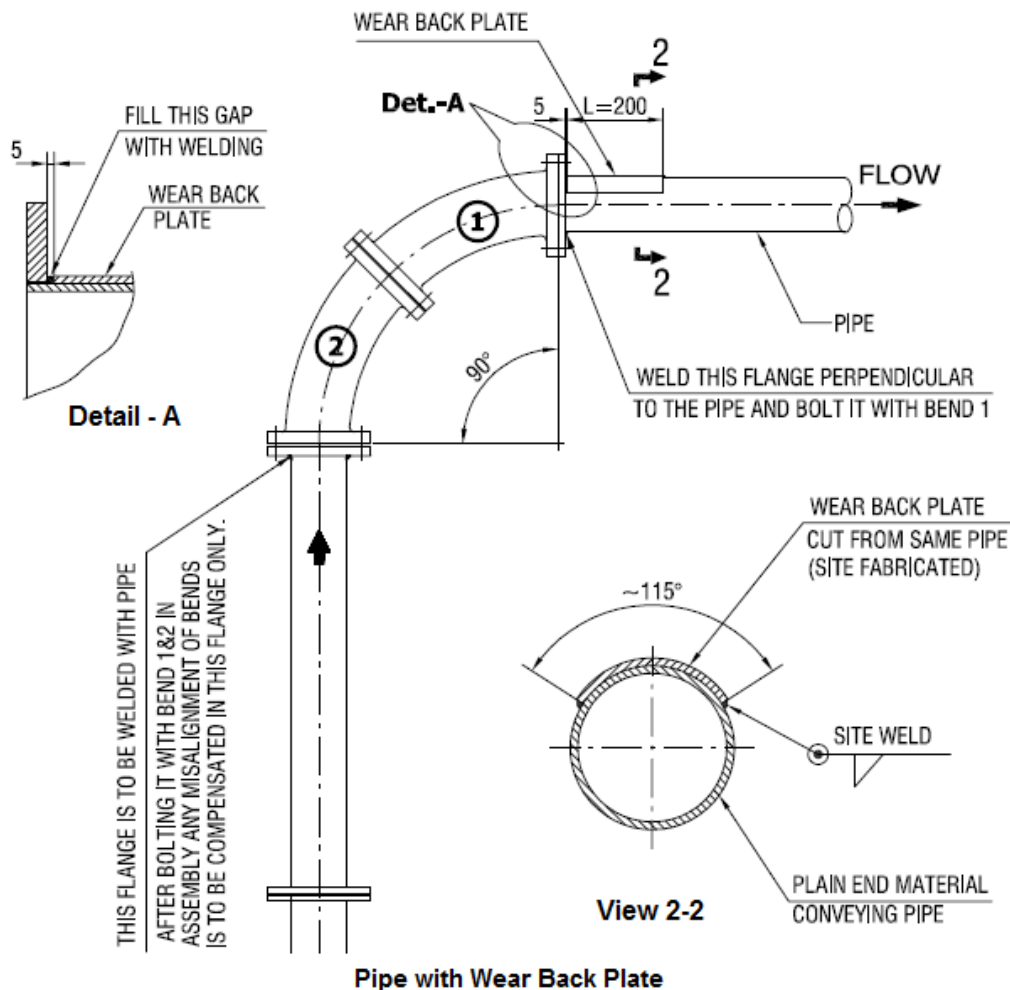

Fittings

Fittings are typically made of chromium cast iron. These sand cast components are heat treated to hardness of 320 to 600 BHN. A complete range of elbows, tees, laterals, reducers, etc. are manufactured to allow for various piping geometry.

Many fittings are available with replaceable wear-back (RWB), which are of thicker section than the rest of the fitting and can be replaced many times before the entire fitting wears out. Symmetric (rotatable) wear-backs allow extension of the life of the wear-back itself by permitting its rotation. To extend life of a wear-back, it should be rotated periodically to ensure even wear at each end. Replaceable wear-back fittings have a considerable gasket area due to leakage potential. These fittings should be used only on negative pressure conveying systems.

It is recommended to use large radius bends having minimum radius of 5D.

Following figure shows two Ashcolite® (trade mark of Allen-Sherman-Hoff®) replaceable wear-back fittings. These fittings are non-symmetrical. One leg, known as the tangent, is longer than the other. This feature is incorporated so that material flows through the fitting toward the tangent, thus exposing the ash to the replaceable reinforced/thicker impingement area, which lengthens wear life. The tangent also distances the coupling from eddying ash commonly experienced at turns, thereby reducing coupling wear. These fittings have plain ends that connect with sleeve couplings. It allows for easy installation and replacement.

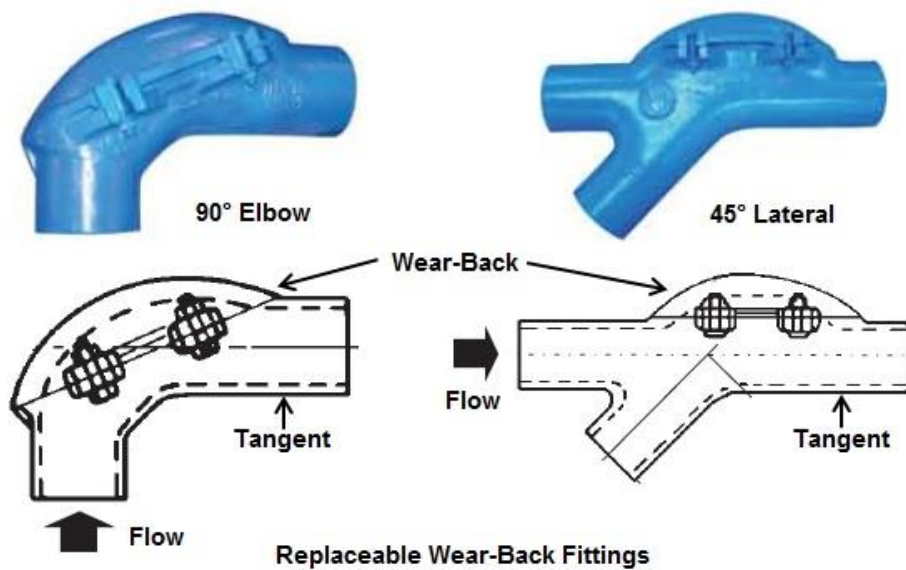

The fitting bodies are available in two grades, A-S-H 65 and A-S-H 33. The A-S-H 65 body has hardness between 400 and 500 Brinell. A-S-H 33 has an improved hardness of 550 Brinell (minimum) for more abrasive applications.

For pressure systems, both hydraulic and pneumatic, fittings with integral wear-back (IWB) are available. These fittings have plain ends that connect with sleeve couplings. It allows for easy installation and replacement.

Following figure shows Ashcolite® (trade mark of Allen-Sherman-Hoff®) 90° elbow with integral wear-back.

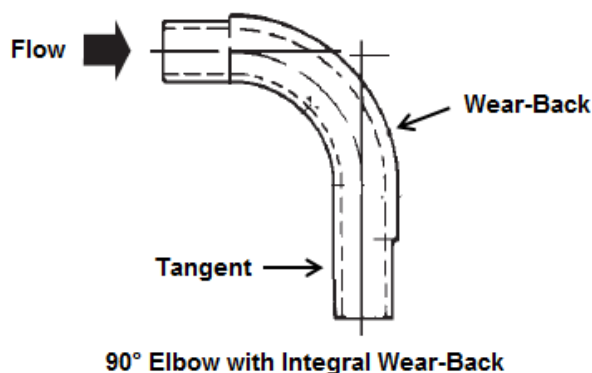

Like Ashcolite® (trade mark of Allen-Sherman-Hoff®) replaceable wear-back fittings, these fittings are also non-symmetrical. One leg, known as the tangent, is longer than the other.

Ashcolite® integral wear-back fittings are also available in two grades, A-S-H 65 and A-S-H 33. The A-S-H 65 has hardness between 400 and 500 Brinell. A-S-H 33 has an improved hardness of 550 Brinell (minimum).

Many times, for severe duty applications, ceramic lined fittings are also used. Ceramic lined pipe and fittings are even harder (hardness of 67 - 68 Rockwell C) and more wear resistant than Ni-hard or basalt. The alumina ceramic lining has a hardness of 9 on the Mohs scale which is considerably more than other abrasion-resistant alloys. ASHcore® is a trade name for ceramic-lined fittings by A-S-H.

For more information on pipes and fittings (like dimensions, weight, basalt and ceramic lined fittings, etc.) supplied by UCC and A-S-H, please see their websites.
 UCC: United Conveyor Corporation - www.unitedconveyor.com
 A-S-H: Allen-Sherman-Hoff® - www.diamondpower.com

Couplings

Couplings for ash piping and fitting take a variety of forms, again specific to the manufacturer. Descriptions of couplings manufactured by A-S-H follow.

Standard single and double couplings connect plain end cast iron pipe and fittings. In systems with low wear, Allen-Sherman-Hoff also offers reducing couplings that connect cast iron pipe with carbon steel pipe.

These couplings accommodate expansion of up to 1/4 inch (6 mm) per length of pipe. This feature often eliminates the need for expansion joints that would be essential in a flanged piping system. Additionally, each coupling can accommodate pipe deflections of up to 3°, adding installation flexibility.

Standard couplings consist of a middle ring, two followers and a set of track-head bolt assemblies. These couplings can accommodate gaps between pipe sections exceeding 1/4 inch (6 mm) by inserting a filler pipe (up to 3 in. for 4 to 9 in. diameter pipe sizes and 5 in. for 10 to 16 in. diameter pipe sizes) section. Double couplings can be used for longer fillers.

These type of couplings rely on the friction force of the gasket material to keep them in place. After a new connection is made, the bolts should be retightened after 3 to 5 days of operation at normal operating temperature. Gasket selection depends on the temperature of the ash conveyed. Systems operating at less than 200°F (93°C) use rubber gaskets, while higher temperature applications use graphite-impregnated fiberglass gaskets.

Following figure shows various types of couplings.

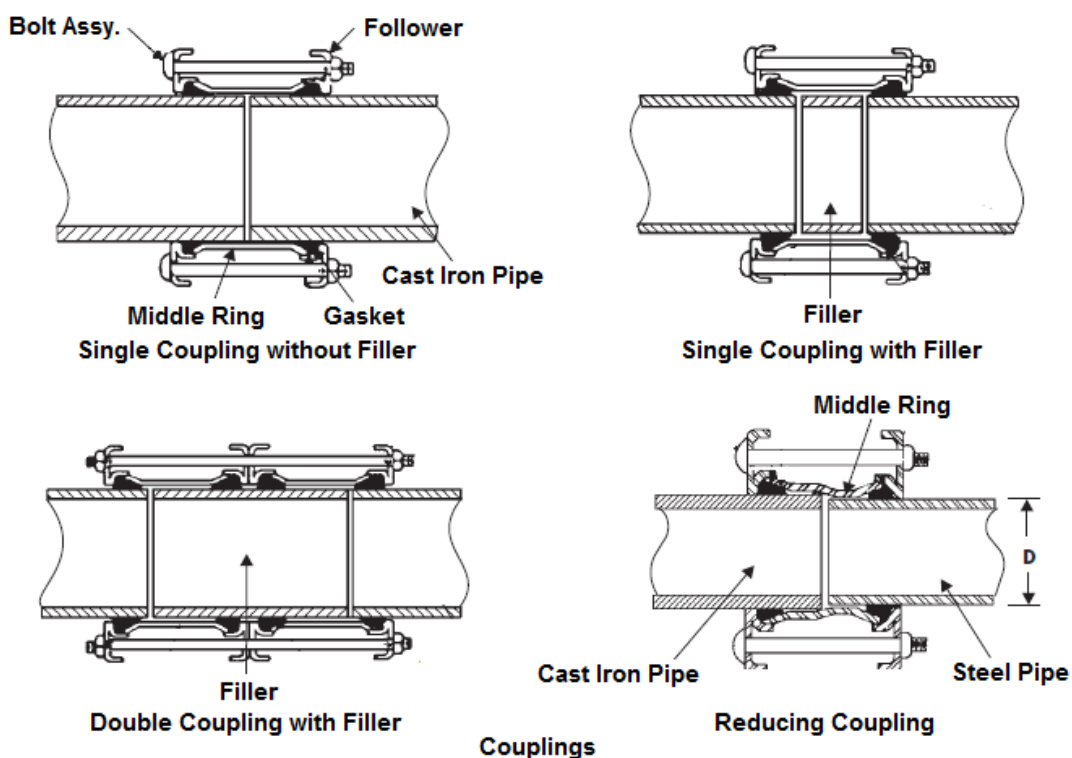

Adaptors and Blind Flanges

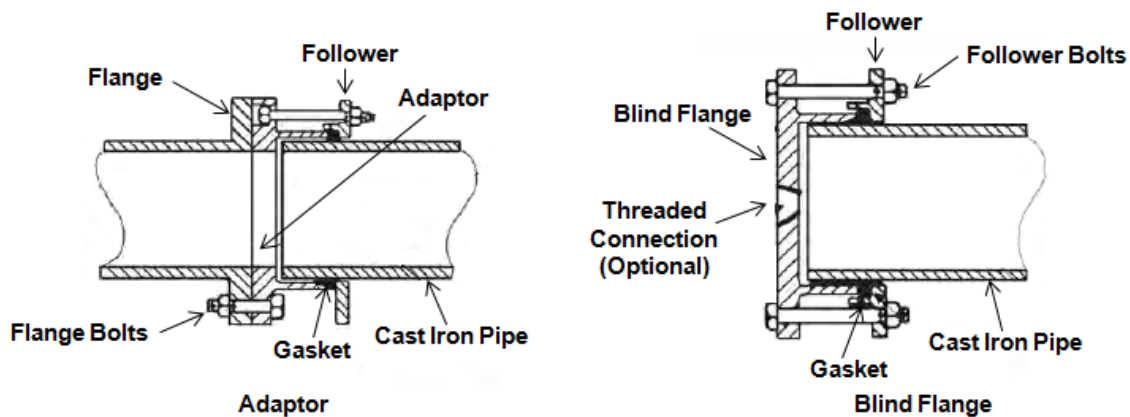

As shown in above figure, adaptors connect cast iron pipe to flange assemblies of all types (for example, standard pipe flanges, fittings, and machinery). Blind flanges close open ended pipe runs and are available with threaded ports for insertion of check valves or testing equipment.

Expansion Joints

In applications requiring greater expansion, expansion joints are incorporated. Expansion joints take several common forms in pneumatic ash conveying piping. The bellows type, with stainless steel bellows to seal against atmospheric pressure and an internal cast iron sleeve for abrasion resistance, is quite common and allows for several degrees of angular misalignment.

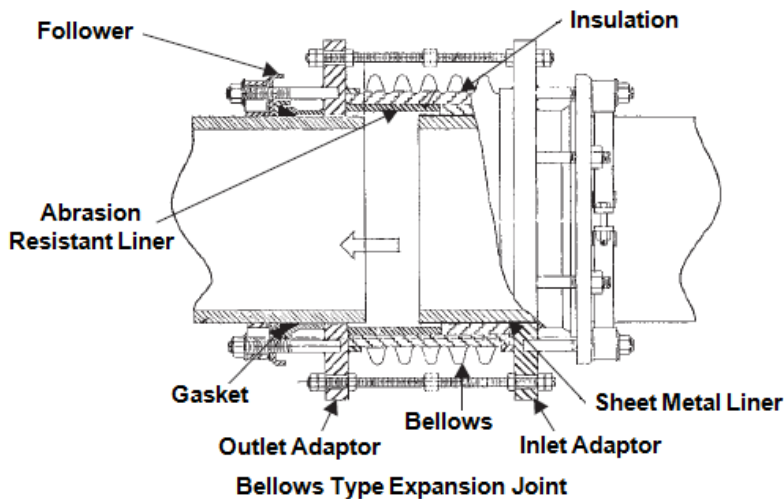

Above figure shows construction of a typical bellows type expansion joint.

It is recommended not to use Dresser-type couplings for expansion joints because they are not designed for wear and will soon leak in service, creating housekeeping problems and/or reduction in capacity.

Expansion joints are used below ash hoppers also. Following figure shows general arrangement drawing (construction) of a typical 300 mm NB SS Double Bellow Type Expansion Joint for installation below ESP hoppers.

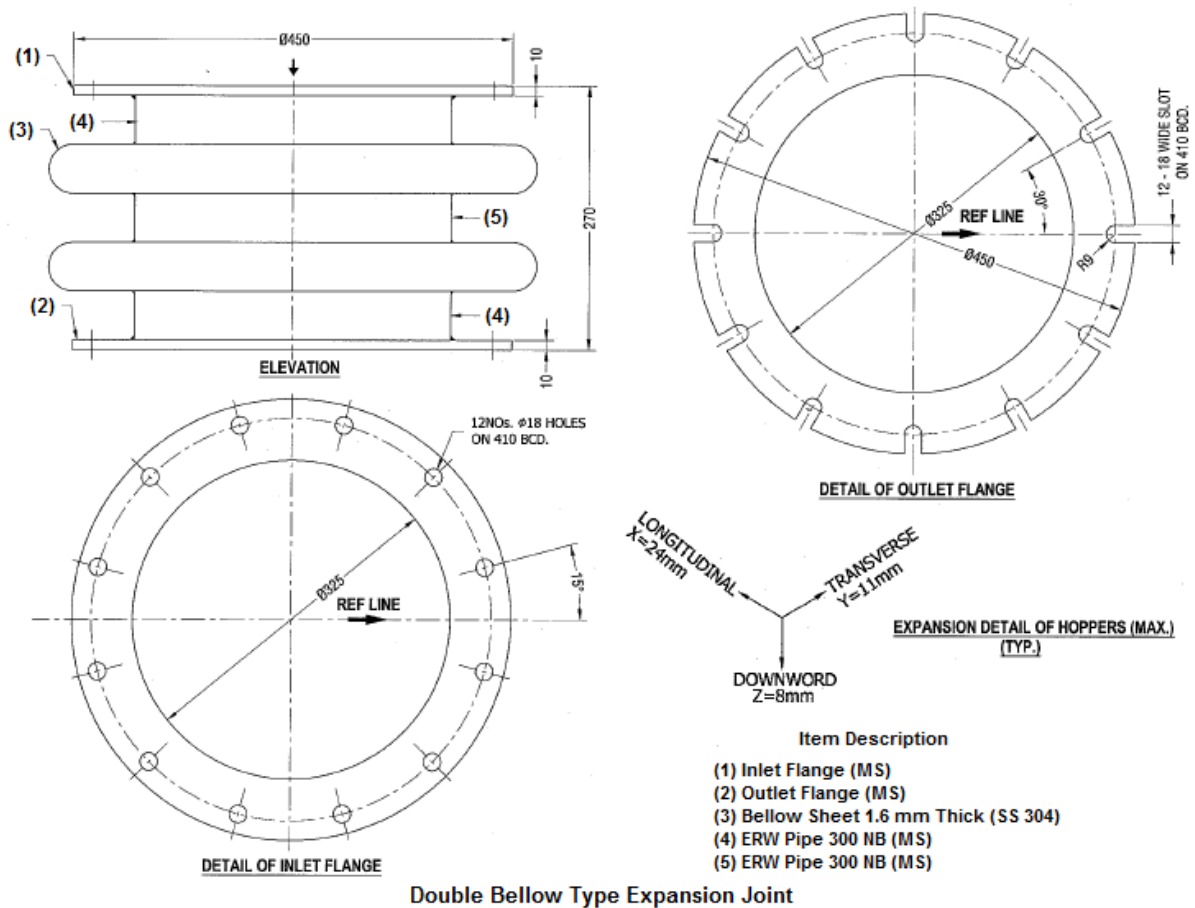

Target/Terminal Box

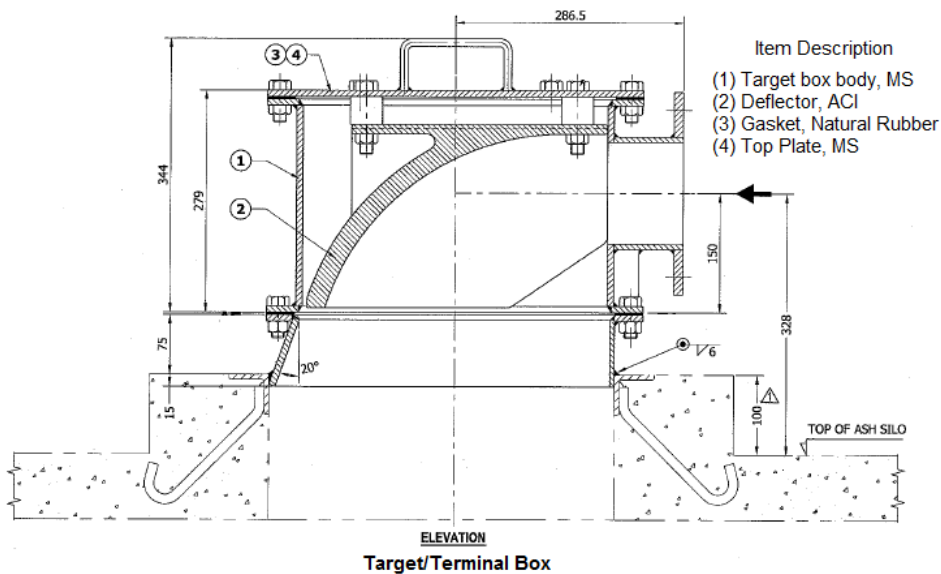

At the end of the ash conveying pipeline, ash is received in a highly abrasion resistant silo mounted target box from which it falls by gravity into the storage silo. Above figure shows general arrangement (construction) of a 125 mm NB Target Box. If number of silos are to be fed in series, a dump valve (not shown) is fitted on each silo instead of a target box except the last silo (which is fitted with a target box). A dump valve has two operating conditions - 'dump' and 'straight through'. A condition is selected based on the silo filling requirement.

Valves for Conveying Material Pneumatically

A wide variety of valve types is used in ash handling applications. Information on commonly used specialty valves for pneumatically conveying of ash is given in this chapter.

It may be noted that the preferred method of metering material is by opening and closing valves completely, as often as required. Valve position (opening a valve partial) is not used to regulate the flow of material.

Hopper and Silo Isolation

Generally manual plate valves (bolt-up gates), manual butterfly valves or hand-wheel-operated knife gates valves are used to isolate a fly ash hopper for on-line maintenance of the ash conveying system. The plate valves are the least expensive and require removal usually of four of the bolts on the typical NPS 8 (DN 200) or NPS 12 (DN 300) Class 150 flange on the hopper. The plate must then be hammered closed or open. Manually operated knife gates are common for this application, but care should be taken to specify the ash temperature for selection of seat and packing materials. Large heads of ash may make knife gate operation difficult, and manually operated butterfly valves have proved quite reliable in this service. Following figure shows general arrangement (construction) of a 100 mm NB plate valve.

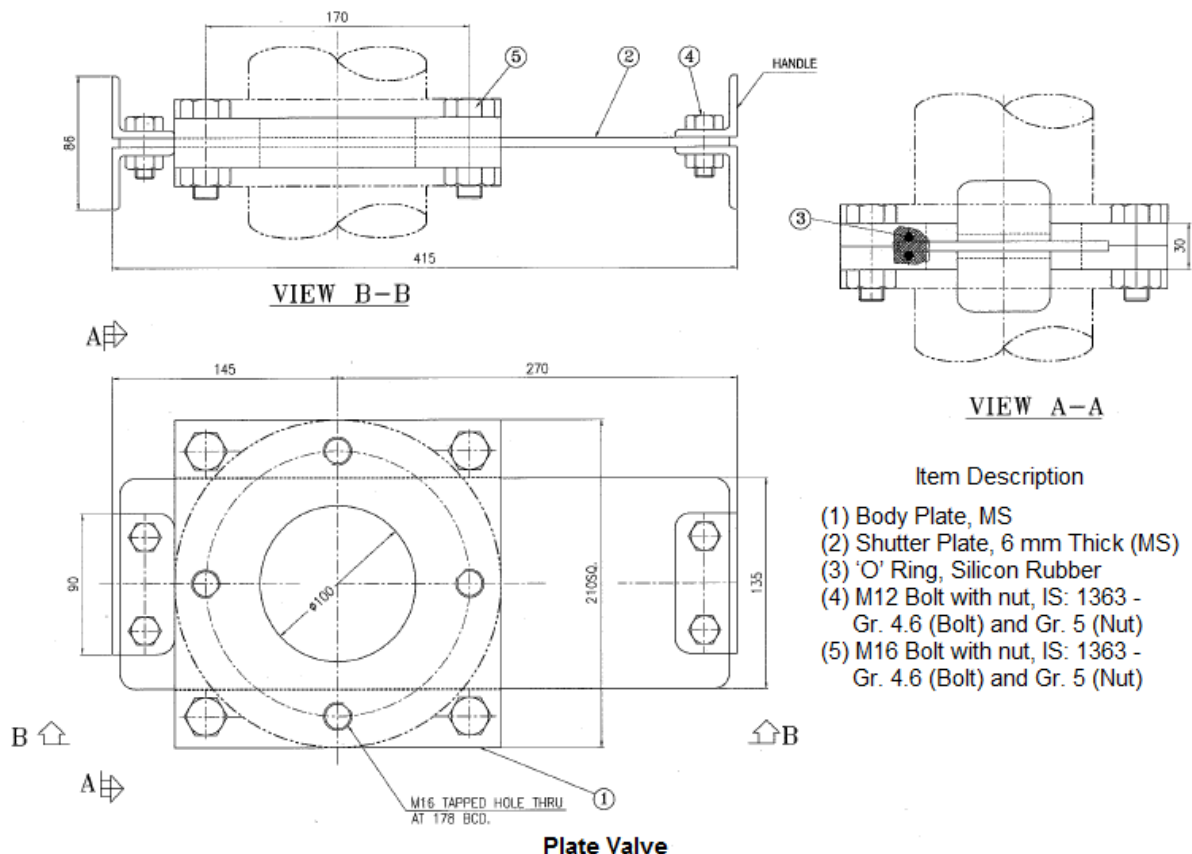

Generally, pneumatically operated knife gates valves are used to isolate a fly ash silo.

Following figure shows general arrangement drawing (construction) of a typical 300 mm NB pneumatically operated knife gate valve to isolate fly ash silo.

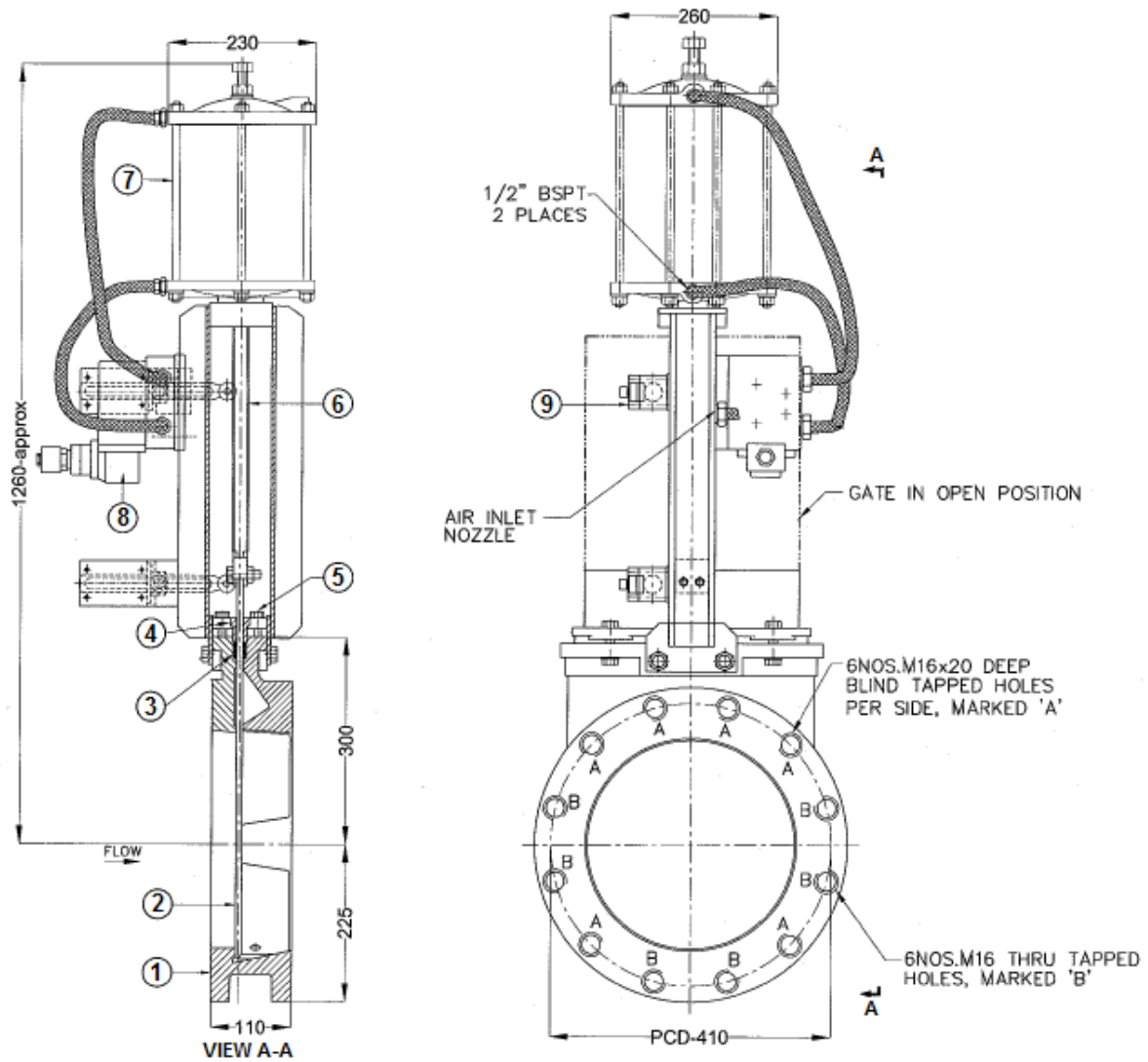

Pneumatically Operated Knife Gate Valve

Item Description (Pneumatically Operated Knife Gate Valve)		
Item	Description	Material
1	Body	IS 210 Gr. FG 260
2	Gate	ASTM A240 Type 304 (10 mm Thick)
3	Packing	Braided Vegetable Yarn
4	Gland	ASTM A536 Gr. 65-45-12
5	Bolts and Nuts	Carbon Steel
6	Piston Rod	ASTM A276 Type 304
7	Actuator	-
8	Solenoid Valve	-
9	Limit Switch	-

Air-Intake

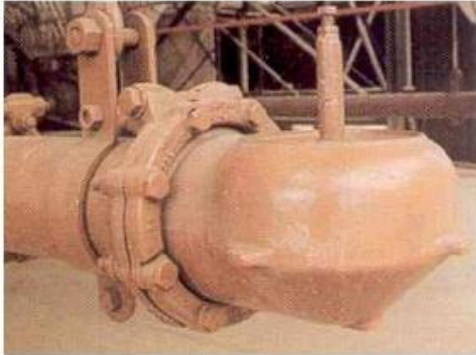

Air Intake

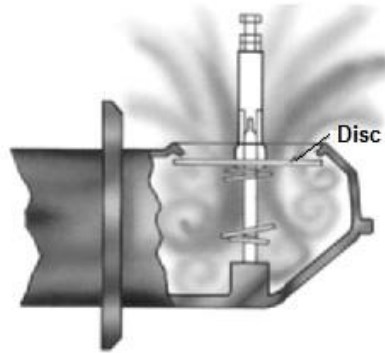

At the end of each branch line in a negative-pressure conveying system, air must be introduced into the conveying line to establish mass flow. The air intake restricts the airflow into the conveyor line and controls vacuum. An adjustable spring-regulated check valve is preferred in this application, although some manufacturers use ball valves or just orifice plates.

Fly Ash Intake

Fly ash intake valves vary widely in design from one manufacturer to the next. While some horizontal slide gate styles are occasionally used, preferred is the swing gate style where the gate swings completely out of the flow of ash to open and closes against a replaceable sharp edged seat. Valves may be hand, air cylinder, or power chamber actuated with manual operators rarely used. Fly ash intake valves are commonly called **material handling valves**. Descriptions of slide gate style and swing gate style valves manufactured by A-S-H follow.

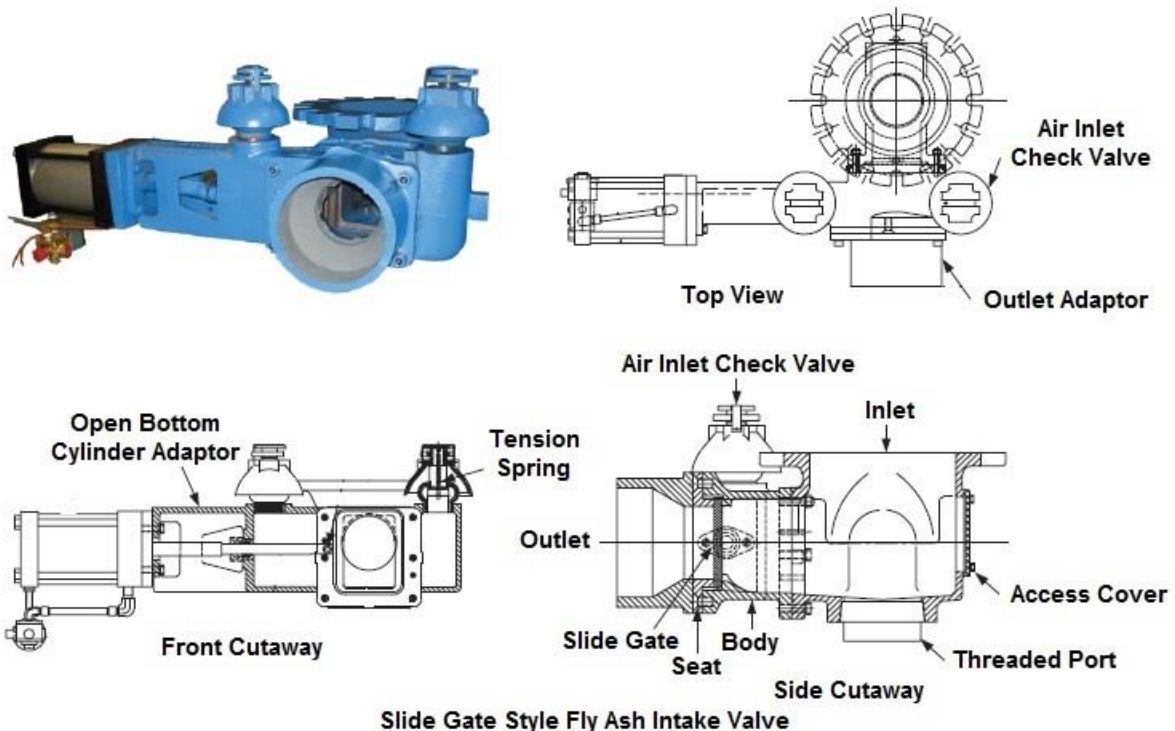

Above figure shows slide gate style fly ash intake valve (A-S-H Type “E” material handling valve). The valve uniformly feeds fly ash into a dilute phase, vacuum conveying system. The valve design allows all fly ash contained in a hopper to self-regulate (by admitting controlled amounts of transport air through inlet check valves) into the conveying line.

The stainless steel slide gate isolates the vacuum conveying system from the storage hopper. The slide gate is machine finished to ensure a flat seating surface which reduces the tendency of damp material to adhere to the gate, and has sharp edges to scrape off material adhering to the seat face or guide tracks. It floats between the seat and guide tracks, on a stainless steel drive pin, so that the vacuum of the transport line pulls the slide gate tightly against the seat. The valve seat is made of hardened ductile iron.

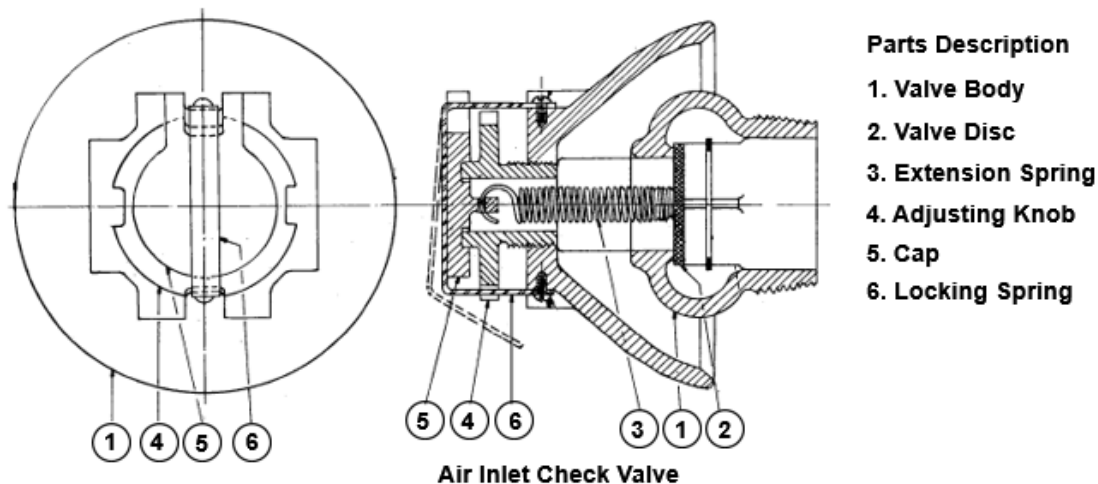

- Parts Description**
1. Valve Body
 2. Valve Disc
 3. Extension Spring
 4. Adjusting Knob
 5. Cap
 6. Locking Spring

Above figure shows construction of an air inlet check valve. Air inlet check valves (spring-loaded poppet check valves) are provided upstream of the slide gate assembly at each side of the outlet. They assist in reducing buildup of material in the slide path due to the high velocity air flow between the valves and the transport line. By admitting controlled amounts of transport air at the point of material pickup, the feed rate is continuous and commensurate with the system’s capacity (these valves should not be closed – it can contribute to possible plugging). A tension (extension) spring allows for field adjustment of the feed rate.

The fly ash intake valve has two access points. A threaded port in the base of the body directly beneath the inlet and a bolted access cover at the rear of the body, opposite the outlet. The threaded port acts as a drain when rinsing hoppers during planned outages. The rear access cover enables removal of tramp iron or lumped material in the event of valve pluggage.

The standard operating mechanism is an air-electric, remote operated cylinder. This consists of a double acting air-cylinder, designed for air pressures between 80-125 psi (5.6-8.8 kg/cm²).

Though stainless steel gate and ductile iron seat are provided as standard offering, upgrades to ceramic or tungsten carbide are also available.

Following figure shows swing gate style fly ash intake valve (ASHandler® fly ash handling valve). The change of flow direction within the valve regulates the ash flow to prevent flooding of the conveying line. The flapper type gate is capable of sealing against a minimum of 20 feet of accumulated hopper ash.

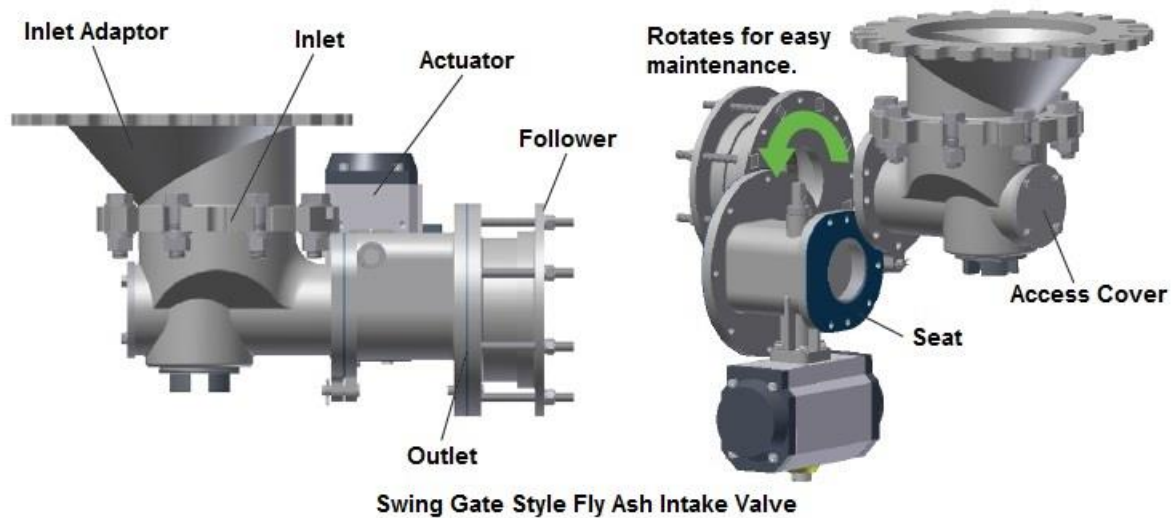

The valve is easily serviceable. The gate housing pivots on a set of hinge pins for full access to the gate and seat. The gate and seat can then be easily removed and safely replaced by a single person without full disassembly of the valve.

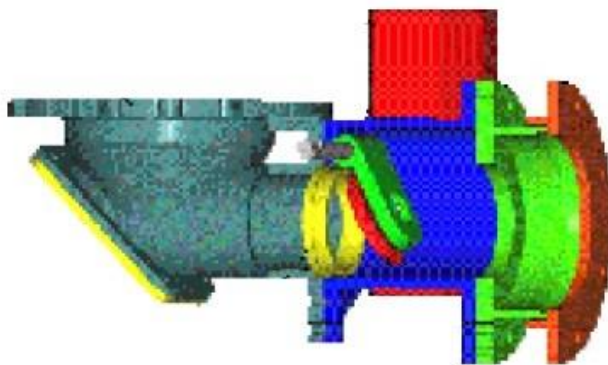

Gate Swings Completely Out of Material Flow Path

Because the valve gate swings completely out of the material flow path, the valve minimizes component wear and increases the service life of the gate.

Standard gate and seat are having a minimum surface hardness of Rc 60. Optionally solid tungsten carbide seat is available for high wear applications.

Branch Line Isolation

Branch line isolation valves are usually knife gate or totally enclosed rotary slide gate. Branch line isolation valves are commonly called **segregating valves**. Descriptions of knife gate valve manufactured by A-S-H follow.

ASHvac® knife gate branch line isolation valve provides high performance isolation of pneumatic lines in vacuum conveying systems.

The floating gate design allows for a positive gate-to-seat seal as well as smoother opening and closing action of the valve. To decrease turbulence, each set of seats is designed to maintain the same inside dimension as the conveying pipe.

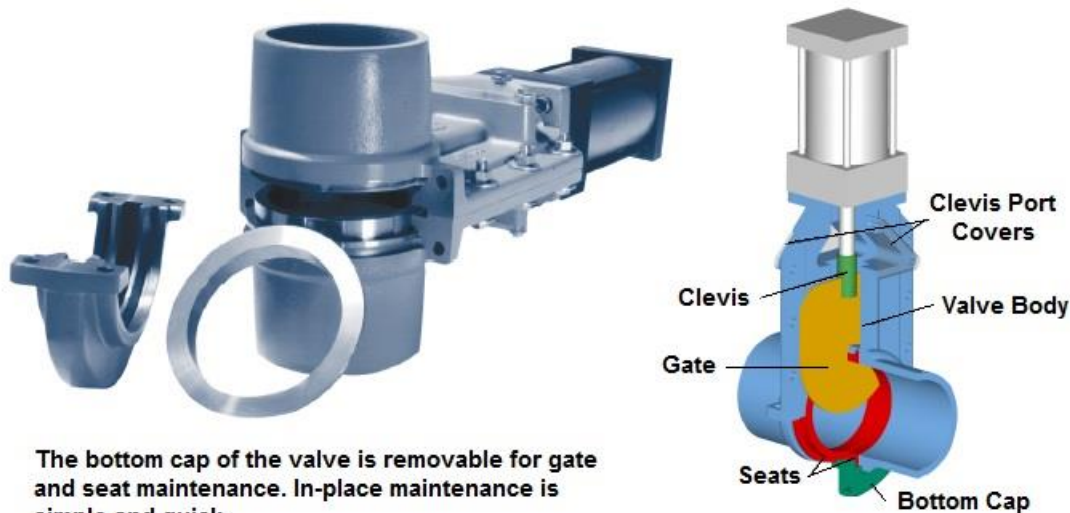

The bottom cap of the valve is removable for gate and seat maintenance. In-place maintenance is simple and quick.

Knife Gate Valve for Branch Line Isolation

As shown in above figure, with the valve body's drop-out bottom, a single maintenance person can replace worn components in a matter of minutes without removing the valve from the transport line.

Knife gate branch line isolation valves are used for positive pressure systems also. Generally, the knife gate branch line isolation valve's gate cavity has a small orifice, which either allows atmospheric air to bleed in, purging the cavity of ash, or is connected to a source of compressed air to accomplish the same purpose in a positive pressure system.

Equalizer Valves (by Allen-Sherman-Hoff)

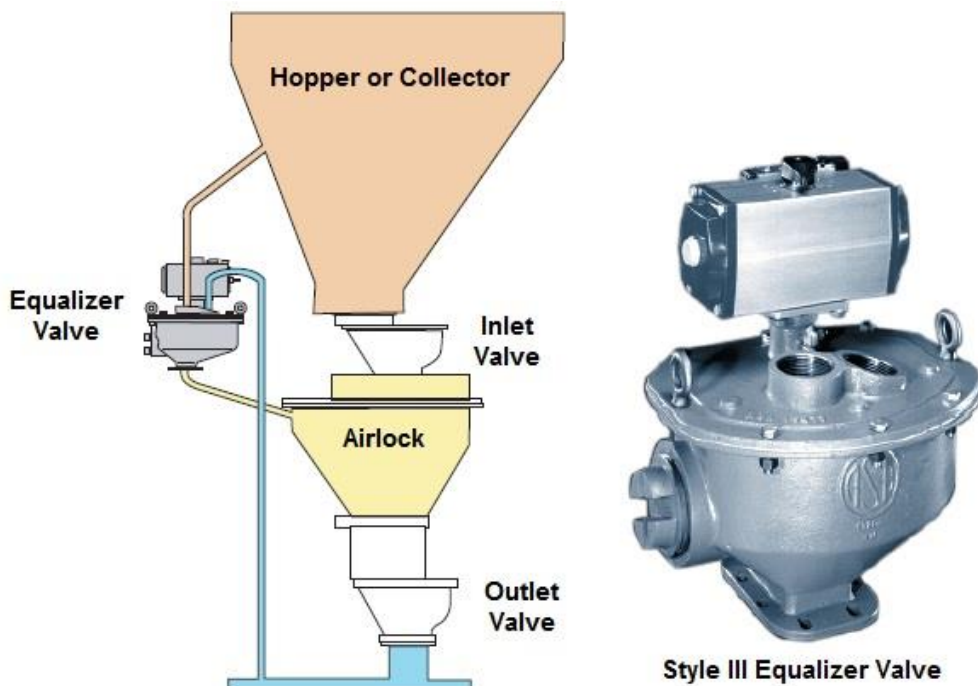

Style III Equalizer Valve between Two Unequal Pressure Zones

Above figure shows Allen-Sherman-Hoff's Style III equalizer valve with rotary-type actuator. The equalizer valve balances the pressure between two unequal pressure zones to promote

the reliable transfer of material from one pressure zone to another in a batch process. The equalizer valve alternately vents and pressurizes a fly ash transfer vessel such as an airlock in a pneumatic fly ash conveying system or a silo mechanical dust collector. As shown in above figure, when material is fed into an airlock, the equalizer valve vents displaced air to the hopper. When the airlock inlet valve is closed, the equalizer valve routes pressurized air into the airlock to transfer the ash into the conveying line.

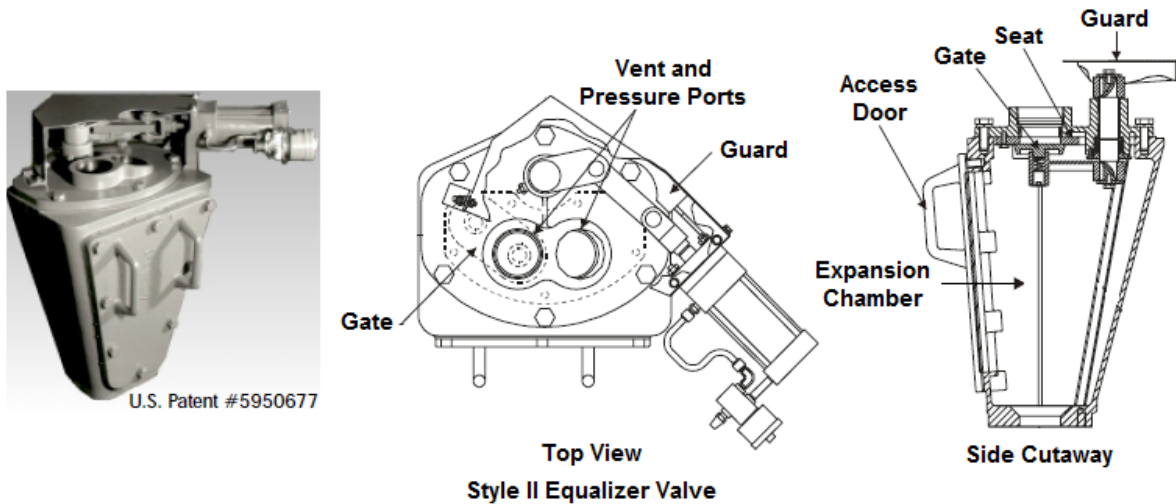

Above figure shows Allen-Sherman-Hoff's Style II equalizer valve operated by double-acting air cylinder.

In above valves (Style II and Style III), the vent port securely seals before the pressure port opens and vice versa. Thus, this three-way design eliminates erosion caused by backflow through the valve.

Style III design offers a fully aerated, a straight through design with horizontal gates capable of shearing through a column of fine material. Style II design provides positive sealing against a high head (25 to 100 feet) and is used under large storage hoppers to handle fine abrasive material.

Style IV design (not shown) has a straight through design and is used in applications involving oil soot, wood bark ash, or coarse granular material.

Sheardisk Valve

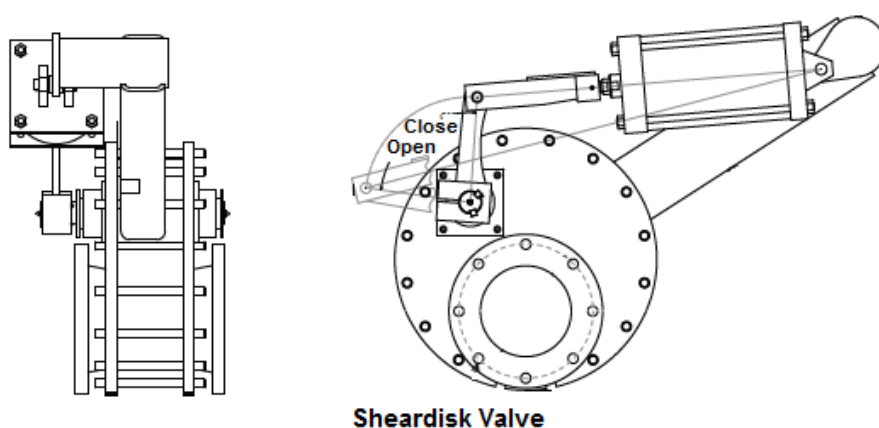

Sheardisk Valves (totally enclosed rotary slide gate valves) are designed for both on/off service and venting/discharge applications in high pressure pneumatic conveying of the most abrasive materials, such as fly ash and limestone. Above figure shows sheardisk valve manufactured by United Conveyor Corporation (UCC) with self-lapping technology. The seat and disk are made from Stainless Steel 440C, 50 HRC.

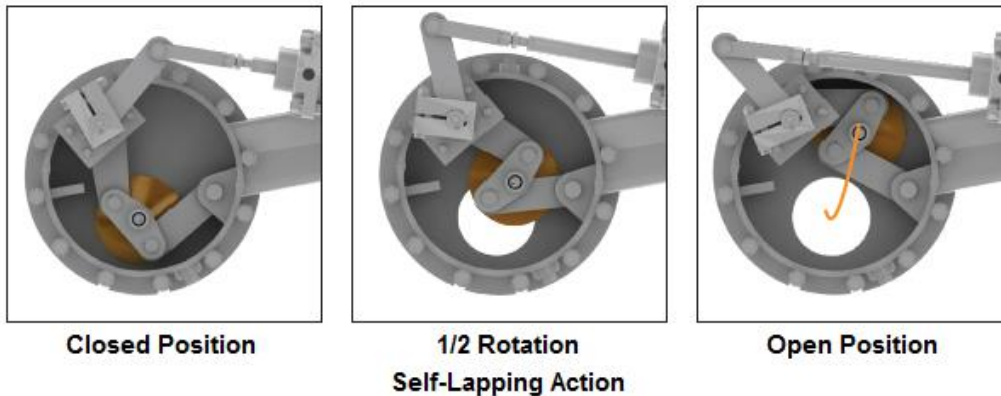

For self-lapping action, as shown in above figure, the valve disk is mounted on the coupler of a four-bar linkage inside the housing causing the disk to travel on a “coupler curve” and rotating against the inside flange. The disk rotates 360° in approximately 20 open/close cycles, with most of the rotation occurring directly over the seat, which is the most beneficial location.

When the valve is close, the interior of the valve remains pressurized which forces the disk against the seat on the low pressure side and assures a tight seal.

Combined Inlet / Vent Valve

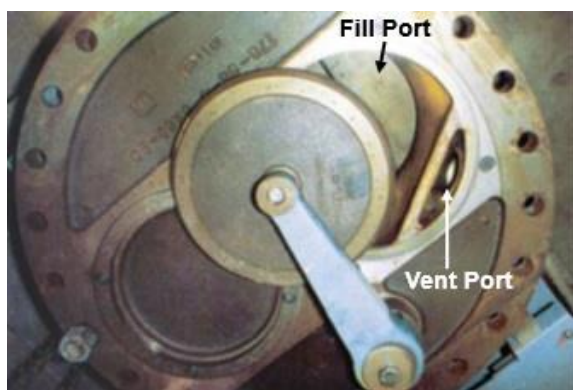

Combined Inlet / Vent Valve

Above figure shows construction of a combined inlet / vent valve by FLSmidth for use in their Modu-Flo MT™ dense phase system. For more information on Modu-Flo MT™ dense phase system, please contact them (website: www.flsmidth.com).

Dome Valve

Originally patented by Macawber Engineering Inc. USA in the late 1970's, the Dome Valve® is unique in its ability to open and close with a tight pressure seal in environment where abrasive materials are passing.

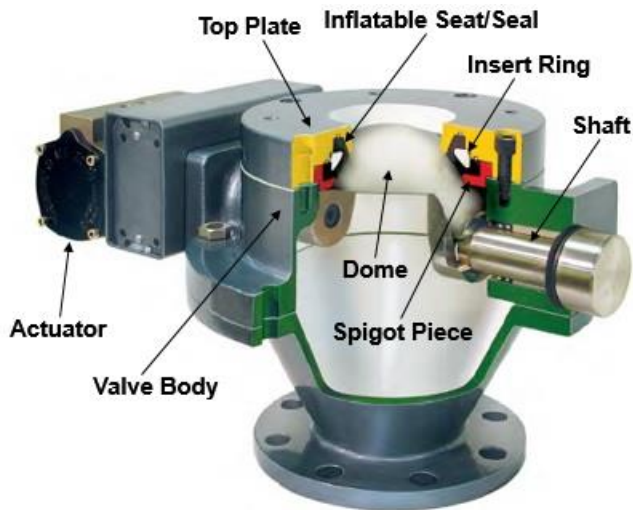

Typical Dome Valve Construction

A dome valve is used in a wide variety of applications. The unique closing and sealing action of the dome valve enables continuous reliable operation where conventional valves fail to perform.

The sealing efficiency and acceptable valve seat life is due to flexible inflatable seat/seal. Inflatable seats entrap particles that are normally the cause of seat erosion. Particles are induced to move across valve seats under the influence of pressure differentials on either side of the closing member. Entrapping particles within a flexible face during the period of valve closure prevents particle movement and considerably reduces valve seat wear. Inflatable seats also allow automatic wear compensation.

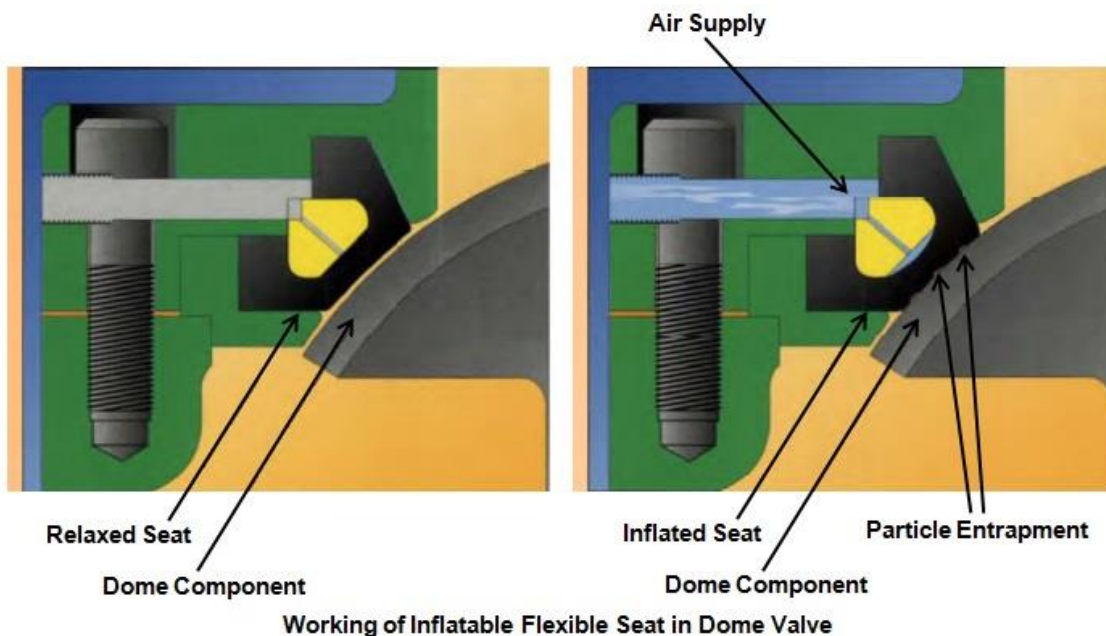

Working of Inflatable Flexible Seat in Dome Valve

Above figure shows construction and working of the inflatable seat/seal. As shown in the figure, the dome component closes beneath the seat when the seat is relaxed (not inflated), allowing a controlled gap between the seat and the closing member (dome). Material is allowed to pass through or enter the controlled gap if, due to its characteristics, it is pulled into the gap by the action of the dome component moving to its closed position. In the closed position, high pressure air or other gas enters the space between the back of the seat face

and the insert ring to cause the seat face to expand onto and around the periphery of the dome component. Material particles are entrapped by the seat against the dome surface, irrespective of particle size or shape. Before opening the valve, the seat is relaxed, and the controlled gap is reestablished before the dome component moves to its open position. The seat is a loose component clamped into place by a spigot piece and external fasteners holding the top plate assembly to the body. The seat is easily removed for inspection.

Dome valves for Denseveyor® are designed to provide a high degree of reliability – up to 500,000 cycles between inspections in approved applications – even when operating with abrasive materials such as sands and ash or coke fines.

Important Note

In case of AFBC/CFBC type boilers, below the bed ash cooler outlet, generally a M.S. water cooled surge hopper equipped with a grizzly (screen) for segregating oversized particles is provided. If the cooling water flow rate to the surge hopper is not adequate (for example due to cooling water line blockage), the ash will not get cool adequately. The hot ash may heat up the dome valve and damage the flexible seat/seal. In view of this it is very important to ensure that the ash is adequately cooled before it is handled by the dome valve.

Pressure/Vacuum Relief Valves

Pressure/vacuum relief valve shall be provided on the storage silos to protect the silos from potential damage due to excessive vacuum or pressure.

The following figure shows sectional view of a typical pressure relief valve where weight is used to set a relief condition. If pressure exceeds a pre-set limit, due to an upset condition, the pressure relief valve will allow air to escape from the silo.

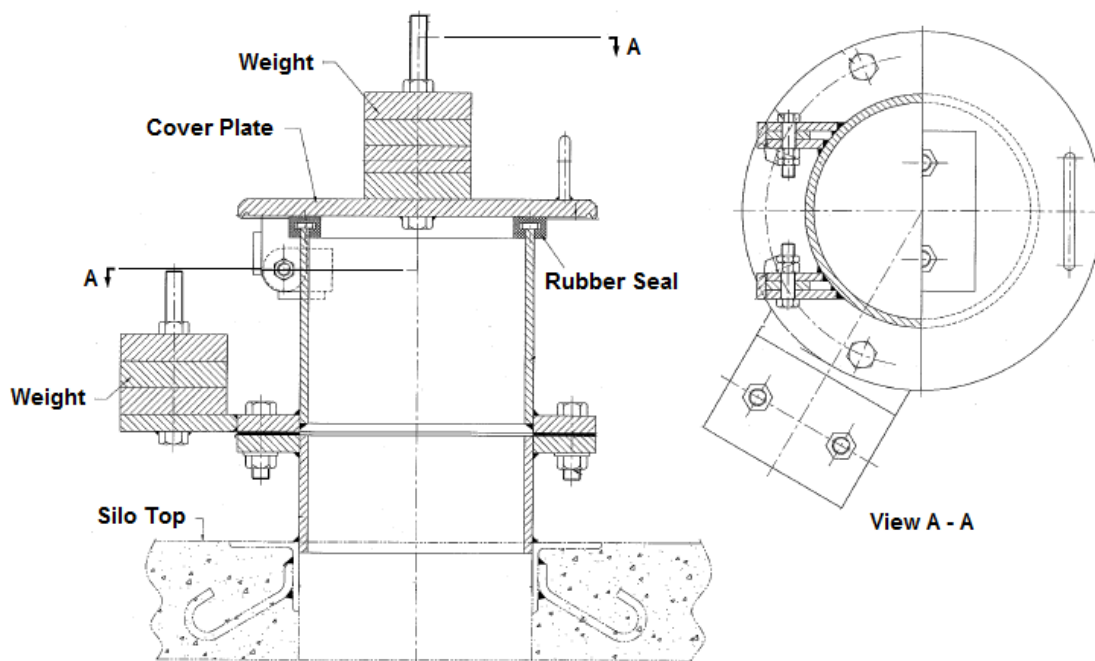

Sectional View of Typical Pressure Relief Valve

Following figure shows construction of a typical spring loaded vacuum cum pressure relief valve.

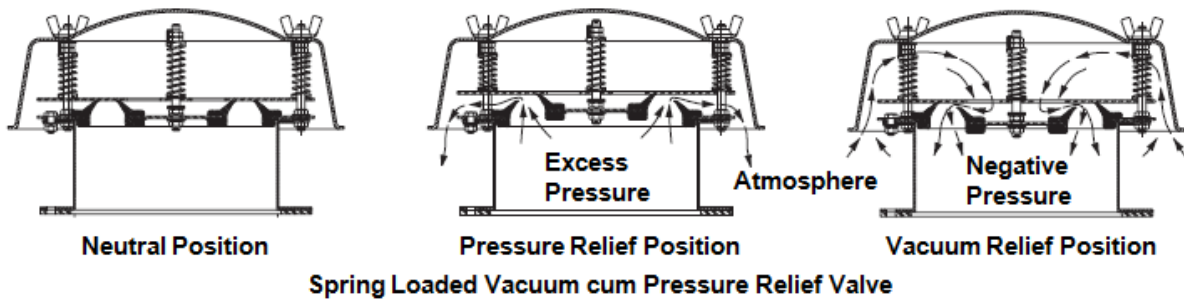

When air pressure exceeds the preset setting of the vacuum cum pressure relief valve, the exhaust port instantaneously opens and expels any excessive positive pressure into the atmosphere. Then, after the preset conditions are achieved, the exhaust port closes and seals. When negative pressure exceeds the preset setting, the exhaust port instantaneously opens to allow atmospheric air to enter the container.

The opening and closing of the vacuum cum pressure relief valve exhaust ports is achieved by spring tension, which can be either factory preset or adjusted in the field.

For more information on vacuum cum pressure relief valves, please see website of Dynamic Air: www.dynamicair.com.

Relief Door / Explosion Vent

A vacuum/pressure relief door is a device installed on enclosed silo roofs to protect the silo from excessive positive or negative pressures that can be encountered during filling and unloading or as a result of abnormal temperature changes. It is designed to relieve a silo from over pressurization or high vacuum conditions by expelling air from the silo or by admitting air into the silo. Many relief doors are equipped with a replaceable diaphragm.

In case the arrangement is designed with a replaceable diaphragm to give an instantaneous opening at a predetermined pressure, it is called an explosion vent. An explosion vent is a pressure relief device. As shown in the following figure, an explosion vent is generally fitted on side of a silo.



Explosion Vent

Care should be taken not to locate vent assembly where personnel are exposed to the vent or the area above or in front of the vent, as they may be injured by the release of pressure, flame, noise, particles, and/or process material.

Pneumatic Conveying System Components

In addition to piping, fittings and valves, various components / equipments are used for handling and conveying materials pneumatically. Information on them and equipments associated with pneumatic conveying systems is given in this chapter.

Water-powered Exhauster

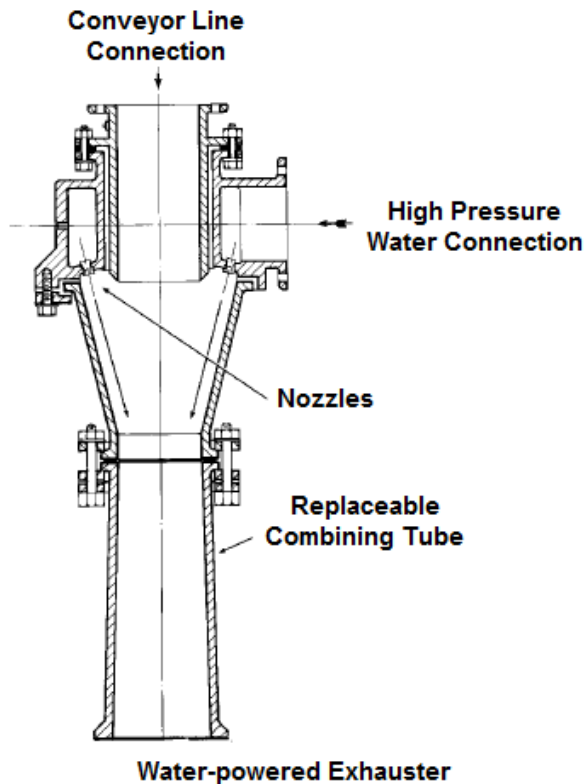

The water-powered exhauster (Allen-Sherman-Hoff's Hydrovactor ®) shown in above figure is a venturi device used to create the conveying air stream for fly ash vacuum conveying systems. High-pressure water supplied to a ring manifold is forced through a number of nozzles, creating a low-pressure (vacuum) area at the exhauster inlet. Air and air/solid mixtures in the pipe are moved toward this lower pressure area by the pressure behind them, thus establishing a conveying air stream. They are available in various sizes handling up to 1200 SCFM and vacuum levels to 22" Hg.

Wherever ash is not separated from the air stream, the water-powered exhauster also passes the ash and air mixture through the water, making a mixture that can be slurried to temporary or final disposal. In such case, to discharge the ash through a pipeline, the air must be removed from the slurry. This separation is accomplished by an ash/air separator tank.

Although vacuum producing performance is not affected, more number of small I.D. nozzles is preferable to a smaller number of larger diameter nozzles. Larger nozzles sometimes cause under-cutting of the throat by water impingement. As a rule of thumb, the exhauster should have approximately 20 nozzles to avoid this problem.

Many designs facilitate easy replacement or cleaning of the exhauster nozzle tips by removal of the access covers.

The main advantages of the water-powered exhauster are, low first cost, simplicity and lack of moving parts. Maintenance and repair consists of replacing nozzles and throat (combining tube) sections as they become worn.

The water-powered exhausters are less commonly used now because of restrictions on use of water and low efficiency. The overall efficiency of water-powered exhausters on the basis of work performed compared with energy supplied is only 30 to 35%.

Hoppers

The reliability of ash removal systems is greatly impacted by design of ESP/baghouse hoppers and other equipment installed in and around them. Many types of equipment are available to assist in the fly ash removal process. Properly selected, sized and installed, it benefits the overall system. Unfortunately, economies are usually attempted with this equipment because it is considered as optional rather than required for more reliable ash removal system.

Valley Angle

The performance of the hopper depends on the angles between the sides and the horizontal, especially the valley angle. As shown in the following figure, valley angle is formed by the intersection line of two adjacent sides of a hopper with the horizontal; the side angle is the angle that a side of the hopper makes with the horizontal.

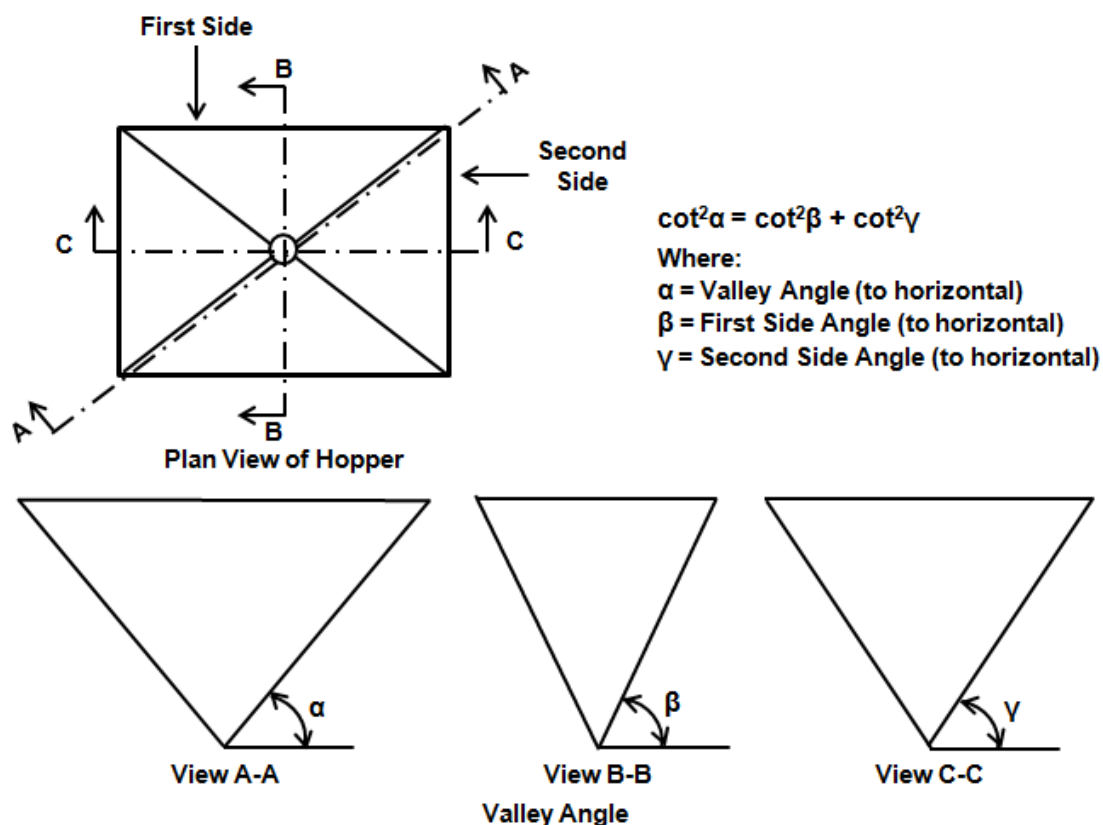

Mathematically, the valley angle α is defined by the following Equation.

$$\cot^2\alpha = \cot^2\beta + \cot^2\gamma$$

For coal ash, the valley angle should not be less than 45° (55° is preferred). If there is some possibility of oil firing, a valley angle of 55° should be used and the hopper equipped with a stainless steel liner.

Air preheater hoppers, because of the relatively high temperature of the flue gas in these areas, tend to have fewer problems with ash feeding to conveyor. Hence, mechanical discharge assist is usually not required.

ESP hoppers however create significant problems in feeding ash to conveyors. The principal problem is the temperature, which is usually just above the acid dew point for the flue gas. As the ash sits in the collection hopper, it cools even though ash is a good insulator. The ash adjacent to the hopper walls cools first and the interstitially trapped flue gas condenses. As condensation occurs, heat loss by conduction accelerates the problem. At low temperature, the hygroscopic fly ash absorbs the resultant moisture. Fly ash particles then agglomerate and set like concrete. A combination of air in-leakage and high carbon carryover (more than 10% carbon by weight in ash) can cause clinkers to form due to sintering. If hoppers become too full of ash, honeycomb and disc like chunks of fused ash are formed by arcing between the ash bed and the discharge electrodes. These agglomeration results in plugging the hoppers. Information on types of equipment available to assist in the fly ash removal process is as under.

Hopper Heaters

ESP hoppers should be heated, insulated, and enclosed. The heat should be applied uniformly to the lower third of the hopper above the outlet. An insulating break should be installed between the hopper outlet flange and the ash equipment to prevent heat loss by conduction.

Hopper heaters minimize cooling of the fly ash, thereby keeping moisture from causing agglomeration. Hoppers although insulated, have large heat losses due to the amount of auxiliary equipment connected with them. Proper sizing and control of hopper heaters is important if they are to perform their intended function. Heaters should be sized to maintain 300° to 350°F in the hopper. A quality insulation job, covering the hoppers and all auxiliary equipment, is necessary so that hopper heaters can perform their function properly. Condensation can occur due to a chimney effect (warm air rises and cold air replaces it) between the external hopper wall and insulation due to poor quality of the insulation job.

Three kinds of mechanical assist are used in ESP hoppers:

Fluidizing - Using aeration stones or pads.

Vibration - Using an internal suspended plate.

Shock - Using either a sledge hammer against a strike plate or using an electromechanical vibrator mounted on hopper slopes.

Fluidizers

Fluidizers are aeration stones or pads installed in the hopper. Warm air fluidizers use heated air as the fluidizing medium to maintain the ash in a hopper warm and fluid. However, care must be taken with fluidizing systems to ensure that only dry, heated (300°F) air is used. If moisture is introduced with the fluidizing air, it may do more harm than good.

However, fluidizing stones or pads are easily defeated by breakage or pluggage and they cannot be replaced with the unit on line.

Hopper Vibrators

Hopper vibrators will not help clear a plugged hopper. When used during ash evacuation, they prevent moist ash from remaining behind on hopper walls. The vibrators must be used to operate only during hopper evacuation (when there is an open flow path, never when the material is blocked by a closed gate), since operation at other times tends to pack the hopper more tightly.

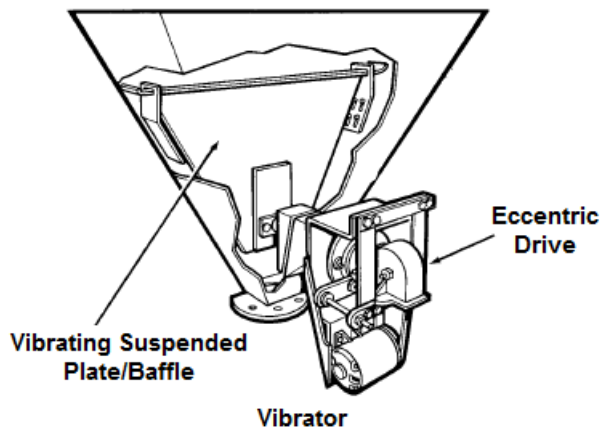

Above figure shows construction of a vibrator using an internal suspended plate with a mechanical linkage to a vibrating motor. Electromechanical vibrators are mounted on hopper slopes also.

Striker Plates

Striker plates, under certain conditions, will help clear a plugged hopper. A strike plate is useful for protecting hoppers from sledge hammers. However, the only sure way to clear a plugged hopper is to get inside and remove obstructions clogging the outlet.

Weather Enclosures

Hopper area weather enclosures are very helpful, particularly in cold climates. Enclosures maintain the area around hoppers relatively warm and moisture-free. They have the advantage of making the operator's inspection visit more bearable and therefore more thorough. For vacuum systems they have the added benefit of providing warmer, dryer air for transport of the fly ash.

Rotary Vane Feeder

A rotary vane feeder can move dry, solid, free flowing material from one pressure zone to another and also can be used to move material at a metered rate. It is used to feed material into a pneumatic conveying system. It is also used to control ash flow into a mixer unloader located below ash storage silo. In many applications in which it is used, its primary function is as an airlock, and so is often referred to as a rotary air lock.

As a feeder between different pressure zones, the rotary vane feeder is most useful for moving material into a lower pressure zone rather than into a higher pressure zone. In other words, rotary vane feeder gives better service on vacuum systems than on pressure systems. Handling of abrasive material causes wear of the rotor tips (vanes/blades) and the housing. As this wear increases, the clearance between them increases, which in turn increases airflow from the high pressure zone to the low pressure zone. If this airflow

coincides with the material flow, the results are not unfavorable. If the airflow, however, is counter to the material flow, the result is either unsatisfactory feed or even no feed at all.

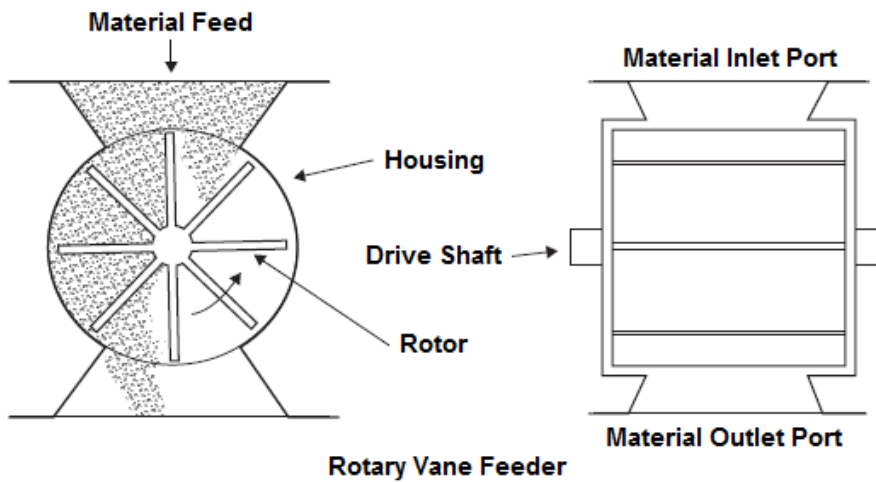

As shown in above figure, a rotary vane feeder also usually referred to as a 'drop-through' feeder consists of a bladed rotor working in a housing. Material from the supply hopper continuously fills the rotor pockets at the inlet port which is situated above the rotor. It is then transferred by the motor-driven rotor to the outlet where it is discharged and entrained into the conveying line.

By the nature of the feeding mechanism, rotary vane feeders are more suited to relatively nonabrasive materials. This is particularly the case where they are used to feed materials into positive pressure conveying systems. Due to the pressure difference across the feeder, and the need to maintain a rotor tip clearance, air will leak across the feeder. Wear, therefore, will not only occur by conventional abrasive mechanisms but by erosion also. Air leakage through the blade tip clearances can generate high velocity flows. This high velocity air flow will entrain fine particles, and the resulting erosive wear can be far more serious than the abrasive wear.

To handle abrasive materials, wear resistant materials should be used in the construction of rotary vane feeder. The feeder should be designed to provide a positive seal between rotor and shoes (wear resistant housing liners). For this, some manufacturers use spring loaded shoes to maintain close tolerances against the vanes. However, many are equipped with inspection ports that permit checking and adjusting clearance between rotor tips and shoes.

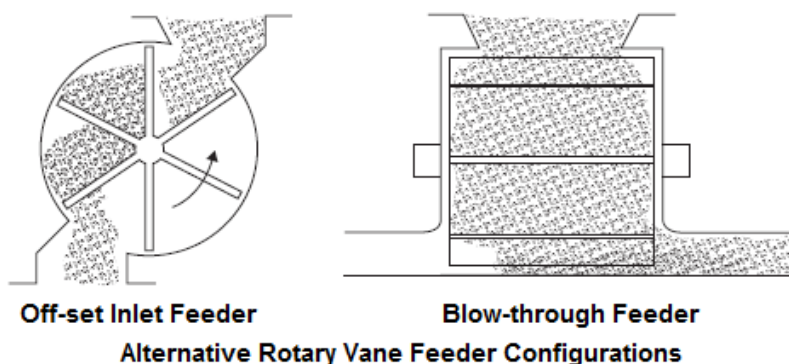

As shown in above figure, alternative configurations are used for special applications. Feeders having an off-set inlet for material feed are often employed in applications where shearing of the material should be avoided. They employ a side inlet, generally with an

adjustable flow control, so that the angle of flow of the material does not permit it to fill the rotor pocket. As the rotor rotates toward the housing, material flows into the trough of the rotor and so prevents shearing. This type of feeder is widely used for feeding pelletized materials.

Another variation of the standard type of feeder is the 'blow-through' feeder. In this type of feeder, the conveying air passes through and purges the discharging pockets such that the material entrainment into the conveying pipeline actually takes place in the feeder itself. These feeders are primarily intended for use with the more cohesive types of material, since these materials may not be discharged satisfactorily when presented to the outlet port of a 'drop-through' feeder.

For an eight-bladed rotor, rotating at a typical speed of 20 revolutions per minute (rev/min), a time span of only 0.375 second is available for the material to be discharged from each pocket. The time available for discharge, therefore, is very short, and although this is generally satisfactory for free flowing materials, it is generally not for cohesive materials and hence the need for the alternative blow-through configuration.

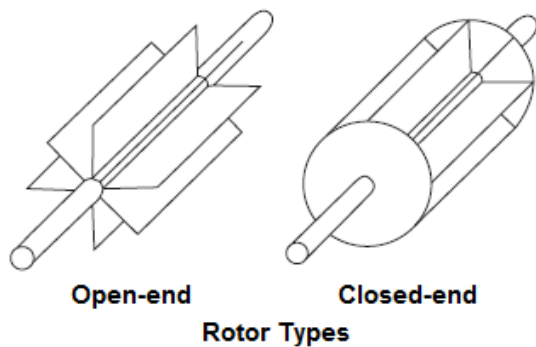

As shown in above figure, rotors are either of the 'open-end' type or 'closed-end' type. With 'open-end' types the blades are welded directly to the driving shaft, while with the 'closed-end' type discs or shrouds are welded to the shaft and blade ends to form enclosed pockets. The closed-end types of rotors provide much more rigid construction and are used for higher pressure and lower leakage rate applications.

Following figure shows the three rotor pocket configurations in widespread use. The most common type has deep pockets and hence maximum volumetric displacement. This is more suited to the handling of free flowing materials. Due to smaller pockets, the volumetric capacity of shallow rounded pockets is less. This configuration is generally used with the more cohesive types of material that tend to stick in deep pockets. Blade tips are generally adjustable are often employed to maintain operating efficiency. They are generally made of abrasion resistant materials.

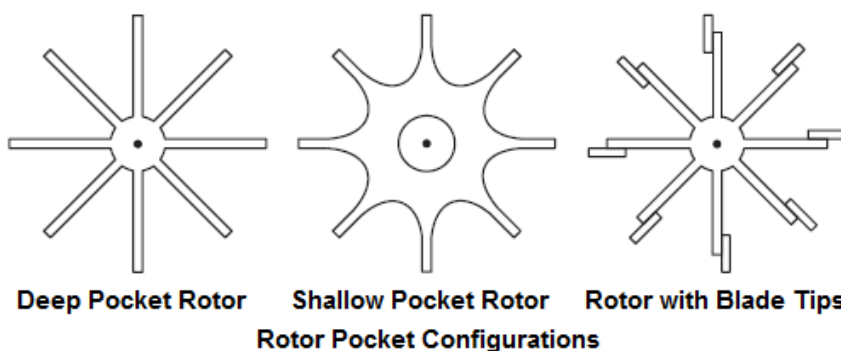

The rotor clearance can have a significant effect on feeder performance, and in an attempt to minimize the effect of the leakage on the feed rate, manufacturers make these clearances as small as possible. Clearances on new rotors are typically of the order of 0.075 - 0.15 mm. Clearances smaller than this would add considerably to the cost of manufacture and may even lead to binding in the housing due to deflection of the rotor, or movement within the bearings, when subject to the applied pressure in positive pressure applications.

The number of blades on the rotor will determine the number of blade labyrinth seals that the air must pass before escaping from the system. From an air loss point of view, therefore, a ten-bladed rotor would be specified for applications with pressure differentials from 0.5 to 1.0 bar. Eight-bladed rotors are commonly used in applications with pressure differentials up to 0.5 bar, and six-bladed rotors where the pressure differential is below 0.2 bar.

The number of blades that can be used in a rotor for handling a material is largely dependent upon the material. Because increasing the number of blades decreases the angle between them, the small angle with some materials prevents them from being discharged when presented to the outlet port. The small angles are certainly inappropriate for cohesive materials.

In the rotary vane feeder, size of the rotor pockets and the speed at which the rotor is driven determine the material flow rate. As the rotary vane feeder is a positive displacement device, the control of feed rate can be achieved quite simply by varying the speed of the rotor. However, following should be considered.

The pocket filling efficiency of a rotary feeder is a function of rotor speed because at increased speed the time available for pocket filling reduces. Up to a speed of about 20 revolutions per minute (RPM), the filling efficiency is reasonably constant. But above this speed it starts to decrease at an increasing rate. There is also a lower limit on speed because of the problems associated with the low frequency pulsations caused by pocket emptying. In view of this, speed of rotary vane feeder is generally between 15 - 25 RPM.

The following figure shows construction of a typical rotary vane feeder used to control ash flow into a mixer unloader. When an obstruction stops the rotor, a proximity probe senses the reduction in RPM and results in stopping the motor.

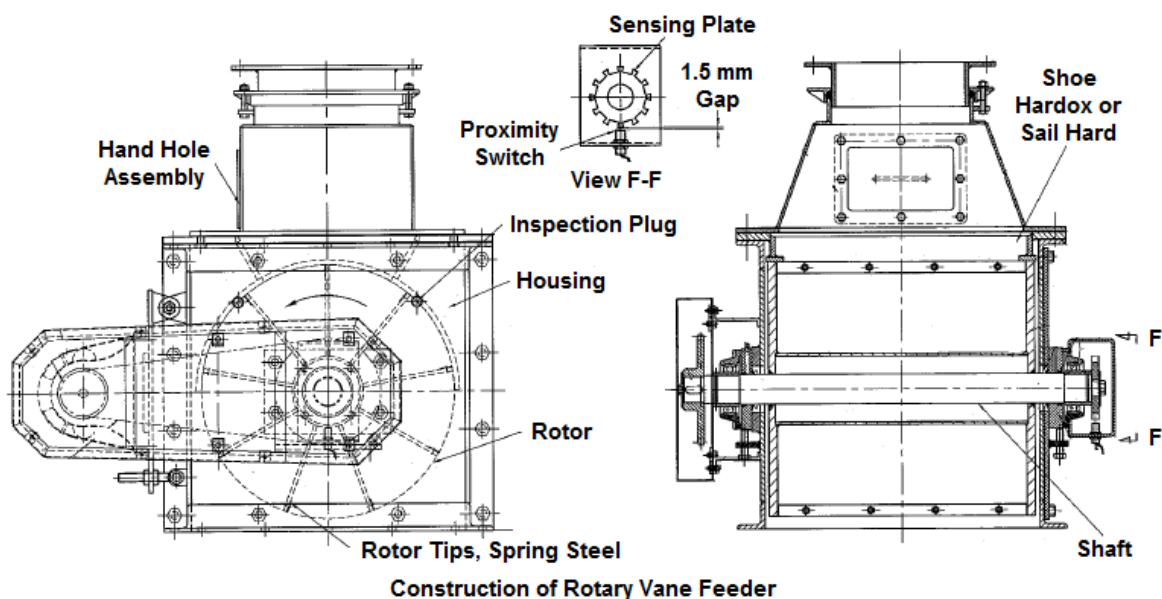

The rotor height is adjusted through jacking bolts so that there is a very fine clearance (approximately 0.2 mm) between shoe and rotor. The liner strips of the rotor may be adjusted if required to have a uniform clearance between liner strips of the rotor and shoe. The gap should be readjusted through the four adjusting (jacking) bolts whenever it increases beyond 0.5 to 1 mm. While adjusting the gap between rotor & shoe, open four inspection plugs and check the rotor & shoe clearance.

Screw Feeders

Screw feeders are positive displacement devices. The feed rate control can be achieved by varying the speed. They can be used for either positive pressure or vacuum pipeline feeding duties. However, air leakage is a problem when feeding into positive pressure systems. Detail information on them is not given here because they have gone out of favor.

Blow Tank

Blow tanks are often employed in pneumatic conveying systems because of their capability of using high pressure air. A high pressure air supply is necessary if it is required to convey over long distances in dilute phase, or to convey at high mass flow rates over short distances through small bore pipelines.

Blow tanks are neither restricted to dense phase conveying nor to high pressure use. Low pressure blow tanks are often used as an alternative to screw feeders and rotary vane feeders for feeding pipelines, particularly if abrasive materials have to be conveyed. Materials not capable of being conveyed in dense phase can be conveyed equally well in dilute phase suspension flow from a blow tank. Depending upon their pressure rating, blow tanks have to be designed and manufactured as per appropriate pressure vessel code, and therefore, can be more expensive than alternative feeding systems.

The blow tank has no moving parts and so both wear of the feeder and degradation of the material are significantly reduced. Another advantage of these systems is that the blow tank also serves as the feeder, and so the problems associated with feeding against an adverse pressure gradient, such as air leakage, do not arise.

In most blow tank systems, the air supply to the blow tank is split into two streams. One air stream pressurizes the blow tank and may also fluidize or aerate the material in the blow tank. This air stream serves to discharge the material from the blow tank. The other air stream is fed directly into the discharge line just downstream of the blow tank. This is generally referred to as supplementary air and it provides the necessary control over the material flow in the conveying line.

Blow tanks operate very similarly to air lock feeders; i.e., they vent, fill, pressurize, and discharge in sequence. The main difference is that the material is “pushed” out through the discharge pipe in a “slug,” rather than being blown into a moving airstream as in a dilute phase pressure system.

Blow Tank Types

Because there are many vendors who offer pneumatic conveying systems, many types of blow tanks are available. However, the basic features of different types of blow tanks are essentially similar, but different arrangements can result in very different conveying capabilities and control characteristics. The two basic types of blow tanks are top discharge and bottom discharge.

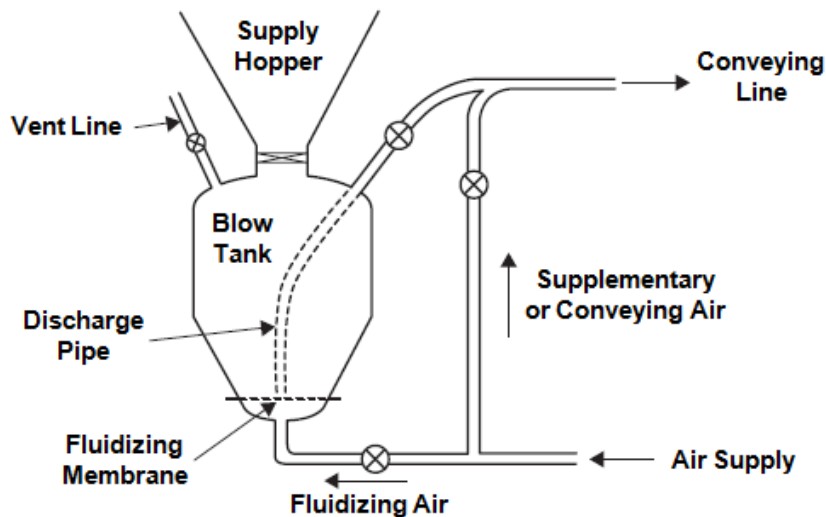

Top Discharge Blow Tank with Fluidizing Membrane

Above figure shows a top discharge type blow tank. This type of arrangement is termed 'top discharge' because the discharge pipe exits the blow tank through the top of the vessel. The discharge is arranged through an off-take pipe which is positioned above the fluidizing membrane. The material is discharged vertically up. It is provided with a discharge valve so that it can be isolated from the conveying line. It is also provided with a vent line and valve so that it can be de-pressurized. With this type of blow tank, however, it is not possible to completely discharge the contents, although with a conical membrane very little material will remain. Hence to avoid cross contamination, the tank has to be dedicated to a single material.

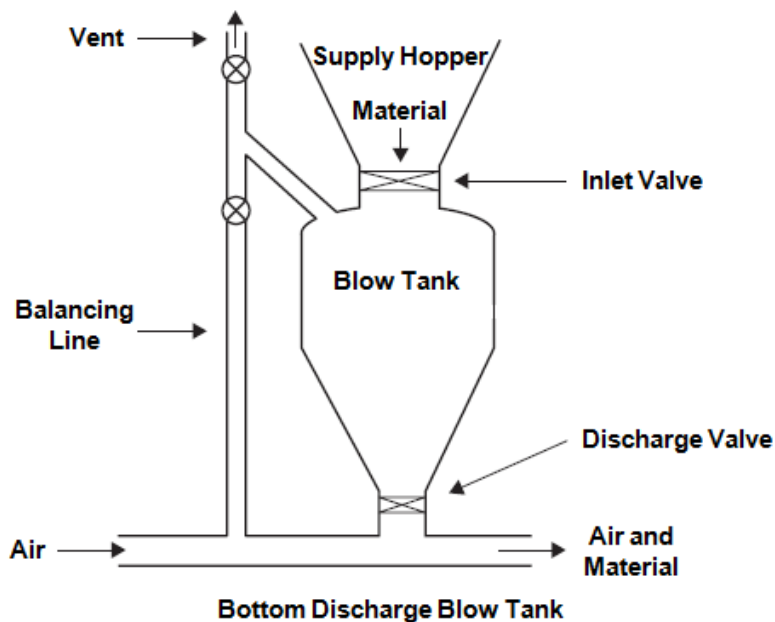

Bottom Discharge Blow Tank

As shown in above figure, in a bottom discharge blow tank there is no membrane. Since the material has an uninterrupted passage to be gravity fed into the pipeline, the material can be completely discharged. This arrangement is commonly found in the industry as most materials can be conveyed with this type of blow tank. For those materials for which it will not work very well, it is suggested to modify the arrangement by adding an air supply to a point close to the discharge point so that the material can be fluidized or aerated in this area,

and that the supplementary air be introduced a short distance downstream, as shown in the following figure.

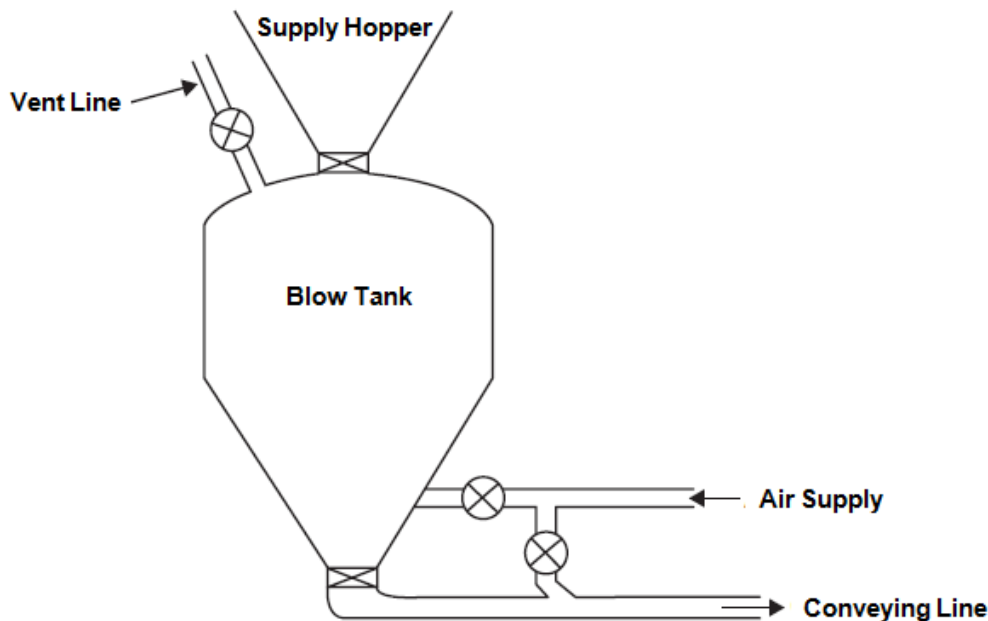

Bottom Discharge Blow Tank with Modified Arrangement

It may be noted that the top and bottom discharge generally refers only to the direction in which the contents of the vessel are discharged. Many different configurations can be created in both top discharge type and bottom discharge type depending on the methods used to admit air to the blow tank and conveying line.

In general, top discharge blow tanks are capable of achieving the highest feed rates and are recommended for materials conveyed in dense phase. Bottom discharge blow tanks are best for materials conveyed in dilute phase as they provide better control for this mode of conveying.

The top discharge type of blow tanks, with fluidization of the material, is most suitable for powdered materials and bottom discharge blow tanks are best suited for granular materials.

Fluidizing Membranes

Fluidizing membranes may consist of a porous plastic, a porous ceramic, or a filter cloth sandwiched between perforated metal plates. The top perforated plate is required to support the filter cloth against the pressure of the air below, and the bottom plate is required to support the weight of the material in the blow tank.

If a porous membrane is used it is important that the fluidizing air is both clean and dry because dust and moisture in the air will cause a gradual deterioration in its performance.

For powdered materials, as shown in the following figure, it is recommended that the off-take pipe be located about 40 mm above the base or membrane. If it is further away the blow tank will simply discharge less material and hence reduce its effective capacity. If it is too close it may adversely affect the discharge rate.

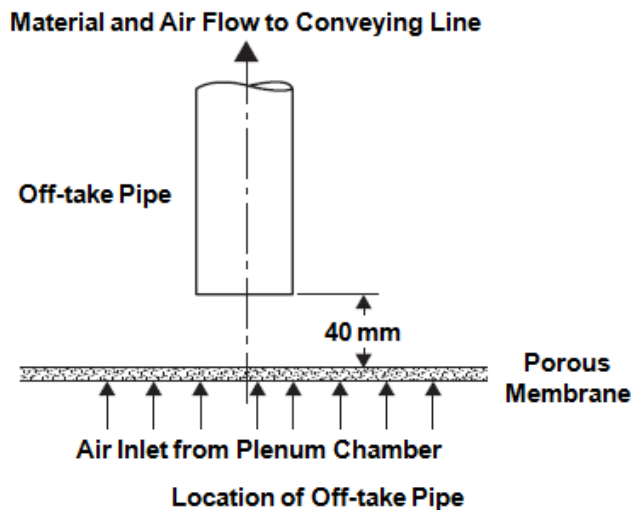

If additional fluidization is required, the end of the off-take pipe may be made conical.

Blow Tank Pressure Drop

The pressure drop across the blow tank is a potential source of energy loss to the conveying system and should be kept as low as possible. In the case of top discharge blow tanks, the discharge pipe must be kept as short as possible because the pressure gradient in this line will be very high owing to the very high material concentration, or solids loading ratio. Supplementary air should also be introduced as close to the point of exit from the blow tank as possible.

Air Drying

With materials such as fly ash and cement, moisture in the air can cause blinding of the blow tank fluidizing membrane, leading to deterioration in performance of the conveying system. Hence, for hygroscopic materials, air drying is normally recommended.

Blow Tank Control

With rotary vane feeders and screw feeders, material flow rate can be controlled, over a limited range, simply by varying the drive speed. However, though blow tanks are not having any moving parts, turn-down ratios of 10:1 can be achieved quite successfully by proportioning the total air supply between that which is directed to the blow tank (pressure/fluidizing air) and that which goes directly to the start of the conveying line (supplementary air). The total air supply is used to convey the material through the pipeline.

The air directed to the blow tank is used to pressurize the blow tank. This air supply may also aerate or fluidize the material, depending upon the bulk characteristics of the material. The blow tank air discharges the material from the blow tank into the conveying line. The solids loading ratio of the material in the blow tank discharge line can be extremely high, and hence there is a pressure drop associated with this feeding. This is why supplementary air is necessary, unless the conveying line is very short and high pressure air is available.

The supplementary air is provided to the start of the conveying line at the blow tank discharge point. The supplementary air effectively dilutes the flow of material for conveying through the pipeline. It is essential that the correct solids loading ratio is achieved at this point in order to match the capability of the air mover in terms of pressure available. If the solids loading ratio is too low, for example, the pressure drop over the conveying line will be

low and the pipeline will be under-utilized. If, on the other hand, the solids loading ratio is too high, the pressure drop required for conveying the material through the pipeline may exceed the capability of the air mover, and the pipeline will probably block.

Thus, for a fixed rate to convey one type of material over a fixed distance, the total air supply can be proportioned between that which is directed to the blow tank (pressure/fluidizing air) and that which goes directly to the start of the conveying line (supplementary air) by onetime manual adjustment of the air control valves provided on these lines.

But, if a blow tank is required to convey variety of materials or just one material over a range of distances, so that the material flow rate will required to be changed, an automatic control facility would be essential. Air supply pressure is the controlling parameter and so some form of feedback control should be provided on the air supply to the blow tank to ensure that the conveying line always works to the maximum capacity that the air supply pressure will allow.

In such case, the most effective way of controlling the blow tank discharge rate is to provide a modulating valve on one of the air supply lines. This will automatically proportion the total air supply between the blow tank and the supplementary line.

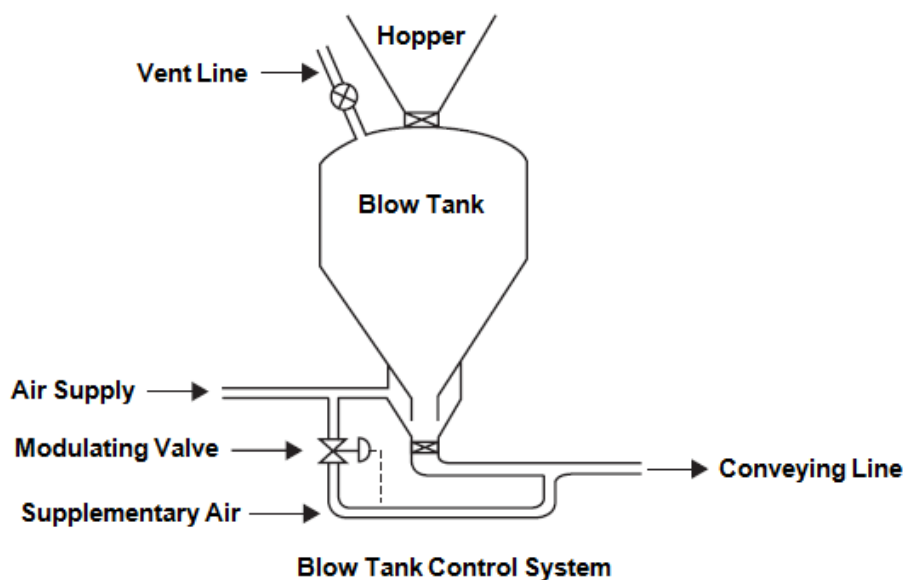

Above figure shows of such a system, fitted to a bottom discharge blow tank. In this case the feedback signal is from the air pressure in the supplementary air supply line.

If the pressure monitored is below the operating value for the system, the modulating valve will restrict air flow to the supplementary line and so more will be directed to the blow tank. With a greater proportion of the air supply directed to the blow tank, the feed rate will increase. If the pressure rises too much, the modulating valve will open a little to allow more supplementary air, and hence the material flow rate will be reduced.

This type of control is particularly useful on the start-up and tail-out transients associated with the conveying cycle. During start-up, for example, all the air will be automatically directed to the blow tank to effect a rapid pressurization, and control will automatically be achieved with lines of different length. The sensing device for the valve is often positioned in the supplementary airline rather than in the air supply line. In the supplementary airline, changes in pressure will be monitored very quickly. In the air supply line, the blow tank has a damping effect and consequently there will be a slight delay in sensing pressure changes.

Twin Blow Tank Systems

When two blow tanks are used in a system, they are called twin blow tank system. There are two types of arrangements in a twin blow tank system. They are parallel and series arrangements.

Blow tanks operating in parallel basically consist of two identical blow tanks, generally placed alongside each other. While one blow tank is being discharged into the conveying pipeline, the other can be de-pressurized, filled, and pressurized, ready for discharging when the other one is empty. By this means almost continuous conveying can be achieved through a common pipeline. However, for this to happen, the blow tank pressurizing process in one blow tank has to be carried out while the material is being discharged from the other. This would require additional air and it would probably not be economically viable for the marginal improvement (continuous conveying) obtained.

Twin blow tanks that operate in series is another term for a single blow tank operating with a lock hopper (also called air lock). In this arrangement, the top vessel is not a blow tank, but is the lock hopper, and this allows conveying on a continuous basis from the blow tank beneath. In case of headroom problem, the lock hopper is sometimes positioned alongside the blow tank.

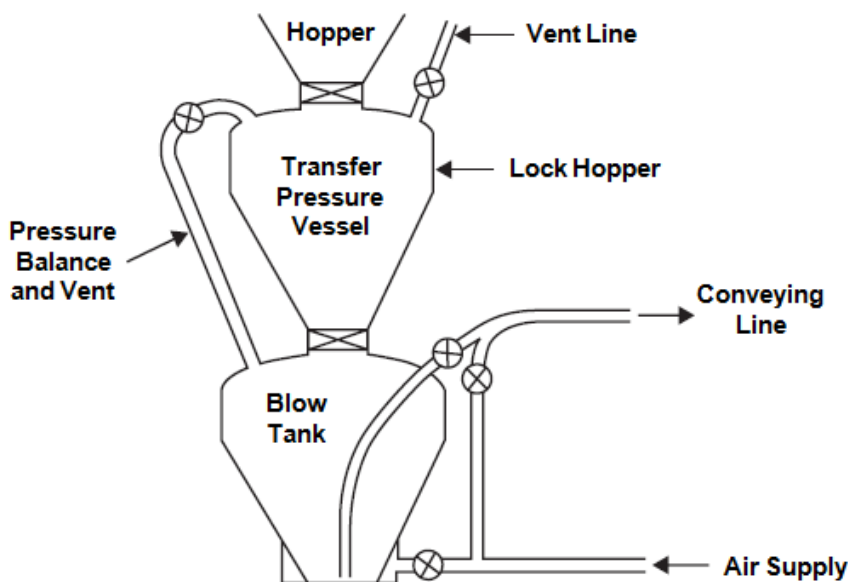

Arrangement of Single Blow Tank with Lock Hopper

Above figure shows arrangement of a single blow tank with lock hopper. The blow tank in the figure is shown in a top discharge configuration, but without a fluidizing membrane. The air enters a plenum chamber at the base, to pressurize the blow tank and fluidize the material, and is discharged via an inverted cone into the conveying line.

The lock hopper, or pressure transfer vessel, is filled from the hopper above. The lock hopper is then pressurized to the same pressure as the blow tank, either by means of a pressure balance from the blow tank, which acts as a vent line for the blow tank while it is being filled, or by means of a direct line from the main air supply. With the transfer vessel at the same pressure as the blow tank, the blow tank can be topped up to maintain a continuous flow of material. The lock hopper will have to be pressurized slowly in order to prevent a loss in performance of the system while it is conveying material.

Once the material has been loaded into the blow tank the lock hopper will have to be vented to return it to atmospheric pressure. The lock hopper can then be loaded with another batch of material from the supply hopper.

Fly Ash Storage and Unloading Systems

With any pneumatic system - vacuum, pressure or combination of vacuum and pressure - provision must be made to store the fly ash for a pre-determined period of time. The system must also provide for the ash to be removed from storage so that it can be transported for sale or disposal. These systems include a storage silo/bin and its accessories, such as fluidizing media, vent filter, pressure/vacuum relief valve, and a device for measuring the level of the silo's contents. Unloading equipment below the silo may include a paddle mixer unloader or a rotary unloader if the ash is to be conditioned for transport in open vehicles; or a dry spout if the ash is to be kept dry and transported in a closed vehicle. Following figure shows typical arrangement of unloading equipment below a silo.

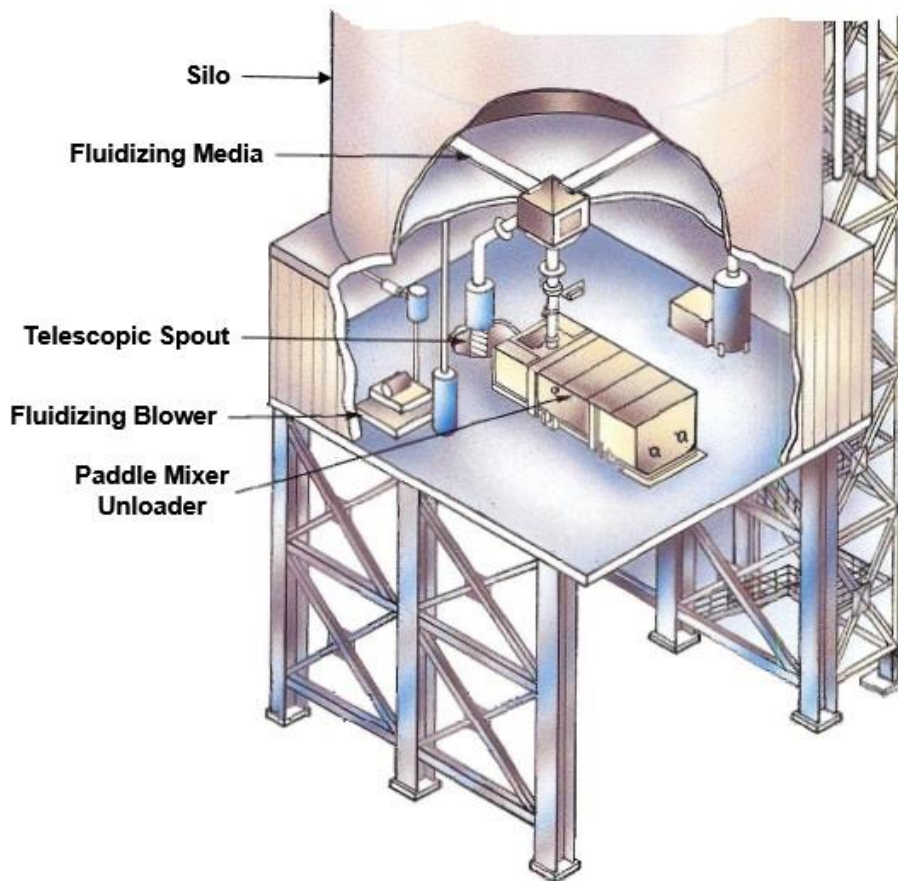

Typical Arrangement of Unloading Equipment Below a Silo

As information on vent filter and pressure/vacuum relief valve is covered in other chapters, information only on silos and unloading equipment is given in this chapter.

Silos

Fly ash storage silos are fabricated in a range of sizes from 16 to 50 feet in diameter. Each silo is designed according to job requirements and may be flat-bottom or conical-bottom construction. The capacity of the silo is matched to the individual system where it will be installed. The silo is usually sized to hold a minimum of three days' ash production, so that it need not be emptied over a weekend. Structural considerations include seismic and wind conditions at the installation site; fluidizing pressure; and the expected range of ash density.

Welded steel plate is one of the standard construction materials for fly ash storage silos. However, for larger installations, a concrete silo can be an economic alternative. The

recommended aspect ratio of height to diameter is approximately 2:1, which is increased for smaller silos and decreased for larger ones. This ratio optimizes cost versus storage volume. Despite this recommended ratio, however, either site space limitations, or the amount and size of silo mounted equipment, may determine the silo configuration.

Whether steel or concrete, access must be provided into the silo for its inspection and maintenance. A man hole is installed on the top of the silo for access to its interior.

Explosion relief panels are installed at the upper perimeter of the silo for those installations where combustible material is likely to carry over into the storage silo, such as bark or wood fired boilers. Should an explosion occur inside the silo, one or more of the panels will give way to relieve the pressure, preventing major structural damage to the silo.

Silo Fluidizing



Silo Fluidizing

Fly ash silos are usually designed with a flat bottom for maximum storage capacity and more consistent output. To assist ash flow to the silo outlet, fluidizing equipment is installed on the floor of the silo. Fluidizing media include diffuser stones, stainless steel or fabric elements, depending on operating parameters. These are arranged so that the aerated ash will move toward the outlet. Motor driven rotary blowers or compressors supply fluidizing air, which may be heated depending upon site conditions. The required pressure of the fluidizing air depends on the silo height and the required quantity of air depends on the silo diameter and floor configuration. The recommended fluidizing air pressures are as under.

Silo Height, Feet	Air Pressure, psig
0 - 29	3
30 - 34	6
35 - 49	9
50 - 54	12
55 - 59	14
60 or more	16

The optimum quantity of air to use is not easily defined. It is generally calculated to be approximately 5 scfm per square ft. of fluidizer (not the silo floor) area. For trouble free unloading, fluidizing should be carried for several hours prior to unloading to relieve compacting forces. If the fluidizing media breaks, the air escapes uncontrolled through the break and fluidizing is lost. The repair cannot be made until the silo is empty. However, emptying becomes more difficult without fluidizing.

Conveying air, fluidizing air and air displaced by ash is vented through a silo vent filter. A pulse-jet cleaned vent filter prevents fugitive dust from entering the atmosphere and keeps the silo pressure below that of the relief valve setting (a relief valve is mounted on top of the silo to protect it from potential damage due to excessive vacuum or pressure).

Level Detection Equipment

In order to determine the amount of material stored in the bin, a level indicator (ultrasonic and/or mechanical type) is often installed in the silo roof. The unit provides continuous indication of the depth of material, and can be linked to a remote control panel.

Ash Unloaders

Fly ash unloaders are intended to add sufficient moisture (10 to 15 percent by weight) to dry fly ash being loaded into open vehicles (trucks or railcars) from silos as to avoid problems with fugitive dust during the unloading operation itself, and during transport to the disposal site.

Consistency is the essential requirement for satisfactory unloader operation: consistency of the physical properties of the ash, and consistency in the rate of feed of the ash. Since the intent is to add a fixed percentage of water to the ash, and the water flow rate is fixed, it follows that the ash rate must be predictable and repetitive (consistent). Achieving this result is as much a function of silo design as it is of unloader design. Because ash is usually not uniform, either in physical characteristics or rate of flow over a period of time, utilities consider unloader/conditioners to be the most deficient type of equipment that ash system vendors furnish.

The three types of unloaders (mixers/conditioners) manufactured for unloading ash into open vehicles are:

- Drum type (rotary) unloaders
- Vertical unloaders
- Screw type (paddle) unloaders

Utilities now have a good deal of interest in twin screw type unloaders. This interest is probably due to the ability of such unloaders to deal with the inconsistencies of ash quality and flow rate, and at least partially overcome them by more thorough mixing.

Drum Type (Rotary) Unloaders

Drum type unloaders are the most prevalent type of unloaders in use after screw type unloaders. This type of unloader mixes the ash and water with a tumbling action. As shown in the following figure, in this type of unloaders, ash is introduced into an inclined, rotating drum at the high end and the ash is mixed with water as it progresses to the discharge end of the drum. Inside the rotary drum, a stationary scraper bar removes wetted material from the surface of the drum causing the tumbling action and resultant mixing. Stop plates (stationary baffle plates) are placed in the drum to prevent direct downhill flow of the unconditioned material. Properly conditioned ash exits the drum through the discharge box and falls through a chute to the transport vehicle.

Generally, a butterfly feed valve regulates the flow of dry ash into the unloader. In attempts to achieve consistent feed, an unloader may be fitted with a rotary vane feeder, or a screw feeder at the inlet.

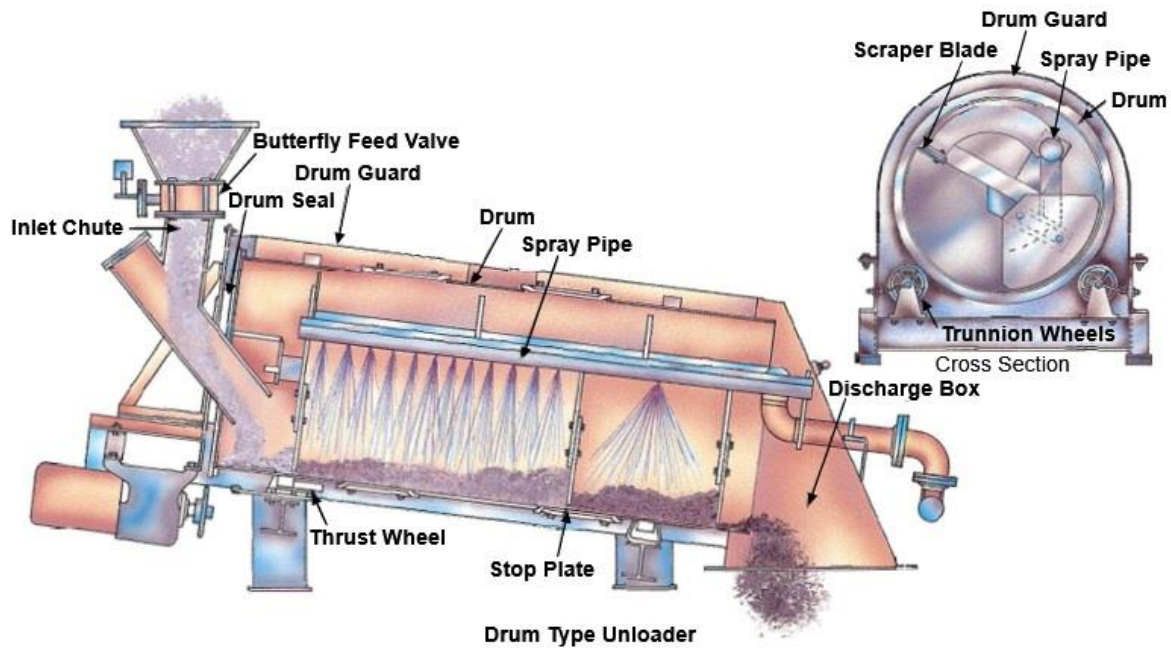

This type of unloader usually is built for a capacity of 50 to 250 tph of conditioned fly ash and requires water at the pressure of 75 to 100 psig.

Vertical Unloaders

Some concerns with drum unloaders are: their requirements for large amounts of space and headroom, and for high horsepower; and their large number of moving, wearing parts. To overcome these concerns, the vertical unloader shown in following figure has been developed.

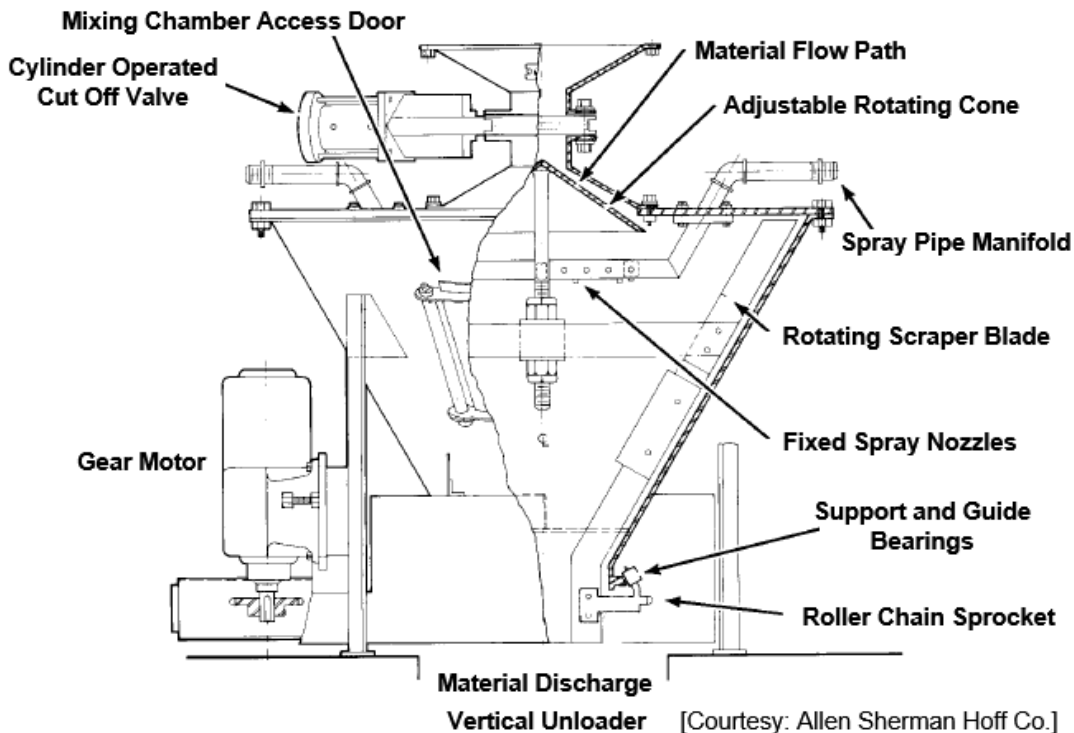

Ash entering the top of a vertical unloader passes between a rotating cone and the unloader housing. Adjustment of the clearance between the cone and the housing is used to meter the ash flow (the intent is to achieve consistent feed). This "thin cylinder" of ash falls by gravity through the mixing chamber and a water spray.

Vertical unloaders rated to 300 tph or more have a headroom requirement of less than 6 feet, and a diameter of less than 5 feet. However, a prospective user is advised to check reference installations carefully.

Screw Type (Paddle) Unloaders

A screw type (paddle) mixer unloader also called pug mill provides a very clean unloading operation.

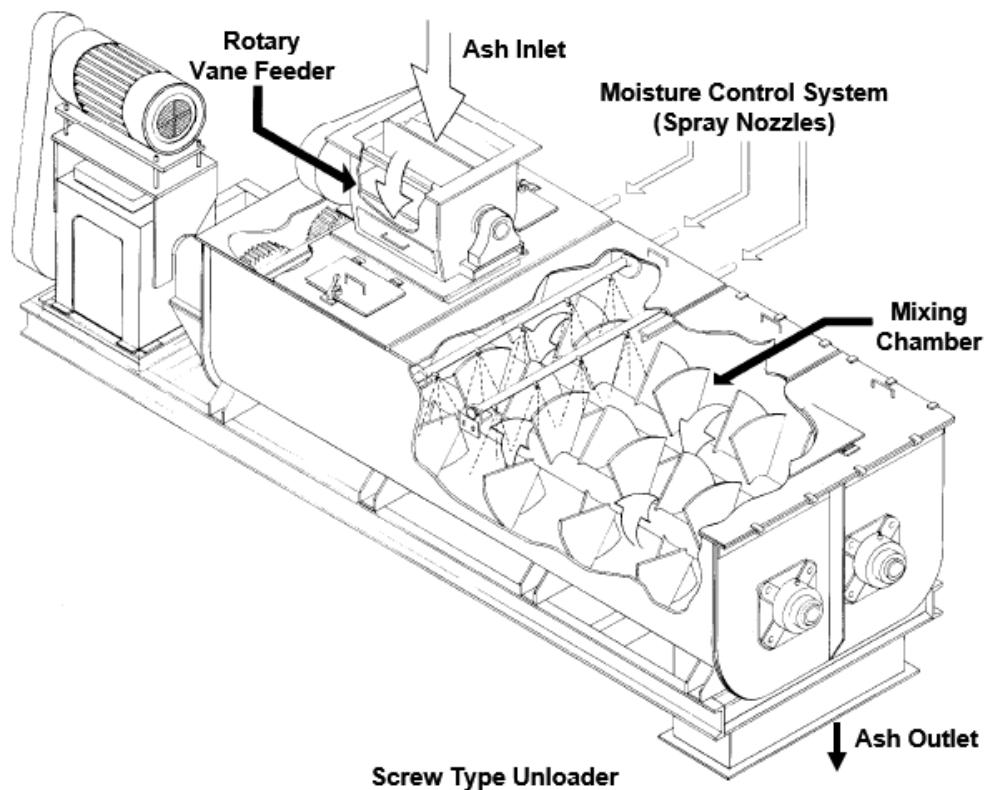

As shown in above figure, a screw type unloader has two horizontal shafts with abrasion resistant paddles attached. The paddles rotate in opposite directions as sets of nozzles spray water on the ash. The unloader creates a homogeneous mixture of water and ash, which moves toward the discharge chute.

The rate of flow from the silo into the mixer unloader must be controlled. Fly ash silos use a specialized butterfly feed valve to control flow. When the storage silo contains a mixture of fly ash and bottom ash, a rotary vane feeder will more precisely control the material feed rate into the mixing chamber. Due to a relatively long retention time, the consistency of the ash/water mix is not significantly affected by moderate fluctuations in ash and water feed rates.

As the screw type unloader is a volumetric unit, throughput (in tons) will vary depending upon the density of the ash. Screw type unloader are manufactured with capacities ranging from 1200 to 16,000 cubic feet per hour, and nominal output of 20 to 400 tons per hour. Generally, for small silos with low volume unloading requirements, a single shaft unloader is

manufactured with a capacity of 750 cubic feet per hour, and nominal output of 10 tons per hour.

If CaO or lime amount in ash exceeds 20% by weight, it becomes cementitious when wet. In such cases, Ultra High Molecular Weight (UHMW) Polyethylene coating on the mixing chamber and paddles and polymer coating material on shafts is carried out to reduce deposit formation.

Telescopic Spout

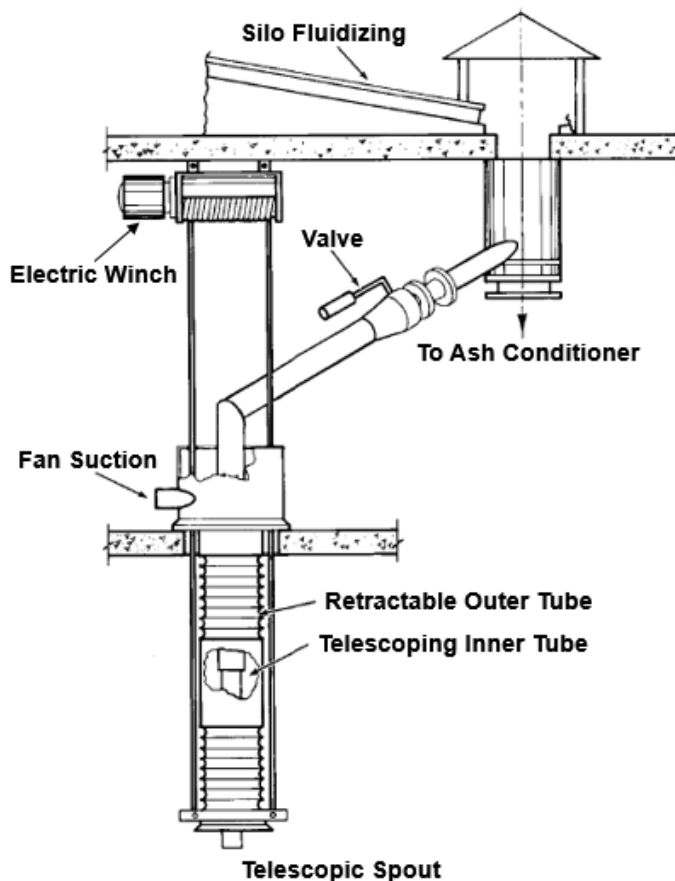

When fly ash is to be sold, or discharged dry for any reason, a telescopic spout is used to empty the storage silo. Above figure shows construction of a typical telescopic spout. It consists of a telescoping tube (usually interlocking loading cones) inside a flexible (fabric/elastomeric), retractable outer tube. The outer tube connects to the inlet flange of a closed carrier such as a tank truck or hopper type rail car. An electric winch raises and lowers the telescoping tube for coupling with the vehicle.

Ash discharges from the silo through the inner, telescoping tube into the vehicle. Displaced air from the vehicle vents through the open space between the concentric tubes, minimizing fugitive dust. An electric powered fan is often used to assist venting of the displaced air back into the silo. Sometimes, dust laden air is drawn through a bag type pulse jet dust collector. Its bags are periodically blown down using compressed air and the accumulated dust falls for collection with the principal ash flow discharging from the telescoping unloading spout.

Since dry spouts provide direct discharge from the silo, they are capable of very high unloading rates.

Note: This chapter is written based on literature by United Conveyor Corporation, USA.

Gas-Solid Separation Devices

Gas-solid separation devices associated with pneumatic conveying systems have two functions. To recover the conveyed material as much as possible and to minimize pollution of the environment by the working material.

Number of devices are available to meet above requirements. Information on them is given in this chapter.

Separation Mechanisms

Different separation mechanisms used based on the size of particles are as under.

If a bulk material consists of relatively large and heavy particles, with no fine dust, it may be possible to collect the material in a simple bin, where the solid material falls under gravity to the bottom of the bin while the gas is taken off through a suitable vent.

However, if a bulk material is of slightly smaller particle size, it may be required to enhance the gravitational effect. The most common method for this is to impart spin to the gas-solid stream so that the solid particles are thrown outwards while the gas is drawn off from the centre of the vortex. A cyclone separator works on this principle.

If particles are fine and especially if they are also of low density, separation in a cyclone may not be fully effective, and in this case the gas-solid stream may be vented through a fabric filter.

For materials containing extremely fine particles or dust, further refinement in the filtration technique may be necessary, for example, use of wet washers or scrubbers and electrostatic precipitators.

In general, the finer the particles that have to be collected, the higher will be the cost of a suitable separation system.

Dust Emission

Airborne dusts which may be encountered in industrial situations are generally less than about 10 μ m in size.

Particles of this size can be taken into the body by ingestion (to take, as food), skin absorption or inhalation. The former is rarely a serious problem and, although diseases of the skin are not an infrequent occurrence, it is inhalation that presents the greatest hazard for workers in a dusty environment.

Particles falling in the size range of approximately 0.5 - 5 μ m, if inhaled, can reach the lower regions of the lungs where they will be retained. Prolonged exposure to such dusts can cause permanent damage to the lung tissues (pneumoconiosis) symptomized by shortness of breath and increased susceptibility to respiratory infection.

Gravity Settling Chambers

The simplest type of equipment for separating solid material from a gas stream is the gravity settling chamber in which the velocity of the gas-solid stream is reduced, and the residence time increased, so that the particles fall out of suspension under the influence of gravity.

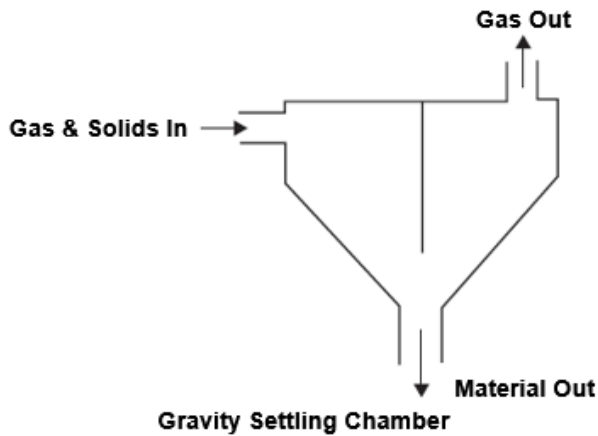

Above figure shows a gravity settling chamber. The rate at which solid particles settle in air, and hence the efficiency of the separation process primarily depends upon the mass of the particles, that is, a combination of their size and density. Hence, settling chambers on their own could only be used for disengaging bulk solids of relatively large particle size (typically particles size greater than about 150 μm).

Cyclone Separators

In a cyclone separator, the forces that disengage the solid particles from the conveying gas are developed by imparting a spinning motion to the incoming stream so that the particles migrate outwards and downwards under the influence of centrifugal and gravitational effects.

In a reverse flow type cyclone separator, shown in the following figure, material is introduced tangentially at the cylindrical upper part of the device, thereby creating a spiral flow downwards. This spiral flow continues down wards of the unit until it reaches a point, near to the base of the cone, where it reverses its direction. The heavy solid particles are then collected from the outlet at the base of the conical lower part while the cleaned gas flows in the opposite direction towards the outlet at the top side.

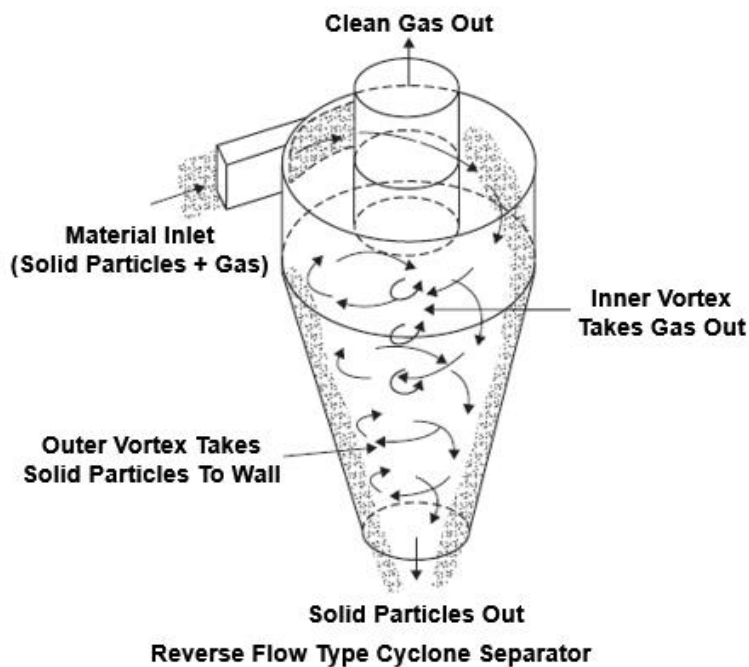

The size of particles that can be separated in a cyclone, and the collecting efficiency, depends on the difference in density of the solid particles and the conveying gas, the solids concentration, the inlet gas velocity and the dimensions (notably the diameter) of the cyclone. Increasing the entry velocity or decreasing the cylinder diameter should normally result in an increase in the collecting efficiency of finer particles, but the practical lower limit on particle size is likely to be around 10 µm.

Bag Type Fabric Filters

In pneumatic conveying systems handling fine or dusty material, the method of filtration that has become almost universally adopted is a bag type fabric filter. These filters are commonly called baghouses. Most baghouses use long, cylindrical bags (or tubes) made of woven or felted fabric as a filter medium.

Dust laden gas or air enters the baghouse through hoppers by suction (normally) or positive pressure and is directed into the baghouse compartment. The heavier dust particles fall off at the entry itself, while the lighter dust particles along with gas get carried upward to the bags. The gas is drawn through the bags, either on the inside or the outside depending on cleaning method, and dust accumulates on the filter media which increases the resistance to gas flow. Due to this, the filter must be cleaned periodically when sufficient pressure drop occurs.

During cleaning, dust that has accumulated on the bags is removed from the fabric surface and deposited in the hopper for subsequent disposal. Depending on the type/construction of baghouse, cleaning can be carried out while the baghouse is online (filtering) or is offline (in isolation).

If gas enters into the baghouse tangentially at the bottom of the casing, it gives the dust laden gas a circular motion which helps in removing the heavy and coarser particles that are present in the gas stream in a manner similar to a cyclonic collector. These collected particles are directly discharged into the hopper. It is only the very fine particles that get carried to and collected by the bags. Thus the total dust load on bags is reduced.

Fabric filters in general provide high collection efficiencies on both coarse and fine (submicron) particulates. They are relatively insensitive to fluctuations in gas stream conditions. Operation is relatively simple. Unlike electrostatic precipitators, fabric filter systems do not require the use of high voltage, therefore, maintenance is simplified and flammable dust may be collected with proper care. However, there are gas temperature limits to the application of fabric filters because of the limits of the fabric itself. At high temperatures, the fabric can thermally degrade, or the protective finishes can volatilize. Accordingly, fabric filters have usually been limited to gas temperatures below approximately 260°C (500°F), which is the maximum long-term temperature of the most temperature-tolerant fabric. They also cannot be operated in moist environments; hygroscopic materials, condensation of moisture, or tarry adhesive components may cause crusty caking or plugging of the fabric or require special additives. Medium pressure drop is required, typically in the range of 100 to 250 mm of water column (4 to 10 inches of water column).

For more information on bag type fabric filters, please see the booklet on “Working, Design Considerations and Maintenance of Bag Type Fabric Filters” uploaded on this website (<http://www.practicalmaintenance.net>).

Electrostatic Precipitators (ESPs)

Electrostatic precipitators are used to overcome the disadvantages of the bag type fabric filters.

An ESP works because of electrostatic attraction (like charges repel; unlike charges attract).

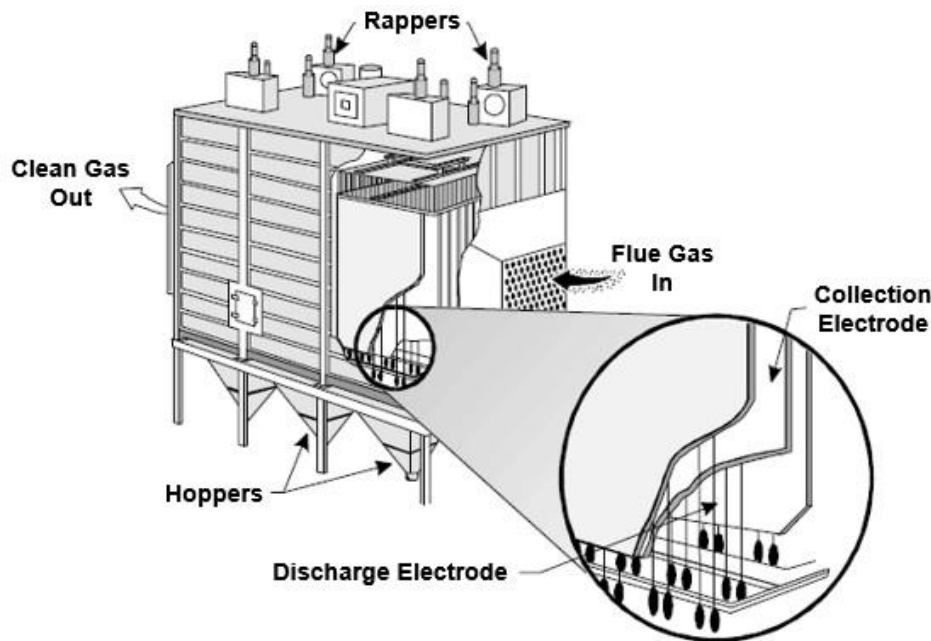

Typical Dry ESP with Thin Wires as Discharge Electrodes

An ESP uses a high voltage electrostatic field to separate dust, fume or mist from a gas stream. The precipitator consists of vertical parallel plates (collecting plates/electrodes) forming gas passages 12 to 16 in. (30.5 to 40.6 cm) apart. Discharge electrodes are electrically isolated from the plates and suspended in rows between the gas passages.

Every particle either has or can be given a charge - positive or negative. A high voltage system provides power to the discharge electrode to generate an electrical field. The particulate, entrained in the gas, is charged while passing through the electrical field. The particulate is then attracted to the grounded collector plate, and forms a dust layer on the plate.

Periodic rapping separates the accumulated dust layer from both the collector plates and discharge electrodes (in case of wet ESP by spraying it with a liquid). The dust layer released by the rapping collects in hoppers and is removed by material / ash handling system.

In short, charging, collecting and removing is the basic idea of an ESP.

ESPs in general, because they act only on the particulate to be removed, and only minimally hinder flue gas flow, have very low pressure drops [typically less than 13 millimeters (mm), (0.5 in.) water column]. As a result, energy requirements and operating costs tend to be low. They are capable of very high efficiencies, even for very small particles. They can be designed for a wide range of gas temperatures, and can handle high temperatures, up to 700°C (1300°F). Operating costs are relatively low. They have long useful life.

However, ESPs generally have high capital costs. Certain particulates are difficult to collect due to extremely high or low resistivity characteristics. There can be an explosion hazard when treating combustible gases and/or collecting combustible particulates. Relatively sophisticated maintenance personnel are required, as well as special precautions to safeguard personnel from the high voltage. Ozone is produced by the negatively charged electrode during gas ionization.

For more information on ESPs, please see the booklet on “Construction, Working, Operation and Maintenance of Electrostatic Precipitators (ESPs)” uploaded on this website (<http://www.practicalmaintenance.net>).

Safety

In general, follow manufacturer's recommendation on safety.

Never enter a bottom ash hopper until the boiler has cooled and all slag has been removed from the tubes. This will help to avoid injury from falling material.

After shutdown of the unit, the fly ash can take a long time to cool down. Therefore, even days after shutdown, the ash can burn personnel coming into contact with it.

Since fly ash may be hot, fatal accident can occur if care is not taken. Hence while dealing with a fly ash hopper, always follow the guidelines given below.

If it is necessary to rod a hopper, either through a hand hole in the ash intake or through a poke hole in the hopper, to clear a plug, the operator must use protection for the body, hands, feet and face against any possible outflow of ash.

Never open a hopper filled with ash except in an emergency.

Never use a ladder for gaining access to a hopper that must be opened.

Never place yourself, or any other person, in the path of an ash flow. If a hopper must be opened, the person opening it must be safely away from the path of any possible ash flow.



Hot/Flammable Dust

- Latch Safety Chain
- Open Door Slowly
- Knock Overhead Dust

Warning for Opening Hopper Door

As shown in above figure, before opening a hopper door, latch safety chain and open the door slowly. Knock overhead dust before entering in the hopper.

No one should enter a hopper for inspection unless the hopper is cool and ventilated. Another person, who is prepared and equipped to help in case of an emergency must be stationed outside the hopper.

Do not enter a silo while it contains ash! The ash may not support the weight of a person, and it is possible to sink into the body of the ash.

Do not enter the silo unless it is ventilated. The silo can be filled with noxious gases. When entering a silo, a person must be standing by outside the silo and prepared to provide assistance in case of an emergency. Oxygen breathing equipment should be available in case the silo is filled with gases.

Conveying burning ash to the fly ash storage silo can be dangerous. Burning or smoldering ash stored in the silo releases gases that can be explosive when mixed with air. The introduction of a single burning particle of ash into a silo under such conditions can cause an explosion.

The presence of burning ash in any hopper probably is a result of a combustion problem.

Troubleshooting and Maintenance

It is recommended to operate and maintain components of an ash handling plant as per supplier's instruction manual. The information about troubleshooting and maintenance is given in this chapter with an intention to provide general information in the absence of information provided by the supplier. Wherever required, explanation for a problem is also presented.

Before troubleshooting can begin, or even establishing that a problem exists, there must be a benchmark of normal performance for a system. This benchmark should be established when the system is new. Usually, this condition is just after initial run-in, when bugs have been eliminated and the system has been fine-tuned by the startup engineer.

While critical components may be replaced on a time schedule to improve system availability, ash conveyor lines can typically be patched or repaired temporarily until maintenance can be scheduled. Systems are usually designed to operate only one-half the time or less, to allow maintenance during the remaining period.

First Steps

Some steps in troubleshooting are so obvious that they are usually overlooked. Checking the following simple possible causes of non-function or malfunction can save time and effort whenever troubleshooting a system. For example, if a system or piece of equipment does not start, check the electrical supply and other basic circuits and equipment:

Are the circuit breakers closed?

Is a fuse blown?

Has someone disconnected a wire, or several wires, for some reason?

Are the air supply valves open?

Is the air supply at the proper pressure?

Is there an abnormal demand on the air supply?

Are water supply valves open?

Are pressure and vacuum switches operating? Has anyone made any changes to the settings which are not recorded?

Note:

A system may not start due to interlocks. For example, a sluice bottom ash system may have interlocks with associated equipment like pyrites conveyor, wet economizer tanks, dewatering bins, etc. Any interlocking permissive may not allow the sluice bottom ash to start. In such case, there should be an annunciation. The causes of the annunciation should be investigated and the necessary corrective action should be taken. Similarly, interlocks can cause the system to shut down or stop conveying ash. Typical problems or malfunctions that may, or may not, be annunciated are: crusher malfunction, loss of conveying water pressure, discharge gate malfunction, high ash level in dewatering bins, etc.

Bottom Ash Hopper

Refractory lining can get damage if the water curtain is lost and the area is alternately subjected to cooling and heating by the wave action of the water in the hopper. The impact of large pieces of ash or slag falling into the hopper can also damage the lining as the material hits the hopper lining if the water level in the hopper is low.

The flushing nozzles within an ash hopper should be inspected for wear. If the water supply contains suspended solids, they can reduce the life of the nozzles. If a nozzle is worn more than 1/16 inch on the diameter, it should be changed as it will affect flushing. If flushing nozzles are incorrectly aligned, they can cause erosion of the hopper lining.

If bottom ash hopper empties slowly, following could be the reasons.

- Large pieces of ash or slag can block the feed/discharge/slucice gate opening and reduce the flow of ash from the hopper.
- Jet pump is worn or the nozzle water pressure is reduced resulting in reduction of its capacity.
- The jet pump does not accept the full flow from the hopper if the ash concentration in the slurry is too high. See the operation and maintenance manual for information on the proper method of slurring the ash before opening the feed gate and for the use of a diluting spray.
- Calcium accumulations in the discharge line can reduce the inside diameter of the line, and thus reduce system capacity.

The seal plate will get distorted or bent if ash accumulates in the seal trough. A major accumulation of ash indicates that flushing is inadequate. If flushing is manually controlled, it may not be performed as frequently as recommended. Inspect the flushing nozzles for wear and alignment.

Feed/Discharge/Slucice Gate

The bottom ash hopper discharge gate can creep away from the open or closed position if the operating cylinder leaks.

The hopper gate opens or closes slowly if the gate and operating cylinder's piston rod are misaligned. The misalignment can cause the piston rod to bind and reduce the rate at which the gate can move. Low operating pressure in the gate's operating cylinder also reduces the rate at which the gate opens or closes.

If the gate cylinder is operated by air pressure applied to a hydraulic reservoir, a low hydraulic level can change the way that the gate operates. Fill the reservoir to the required level.

Suspended solids or scale in the compressed air supply can plug the solenoid valve's diaphragm relief opening and prevent the diaphragm valve from opening. A solenoid valve can be plugged by paint unless all openings are sealed whenever painting is done near the valve (for sealing the valve, use the original shipping plugs or masking tape). In such case, the hopper gate will not open.

Normally a gate is not water tight because of the abrasive nature of the material being handled and the problems of creating a sealing surface. The gate can, however, be adjusted for minimum leakage. See the gate drawings for instructions on the proper manner of adjusting the gate.

Clinker Grinder

If the clinker grinder stalls as soon as the sluice gate is opened and continues to stall during the initial emptying of the hopper section, it indicates that the ash concentration in the slurry from the hopper is probably too high. In this case, the jet pump may not accept the ash at

the rate at which it is flowing. If the ash is not accepted, it accumulates in the crusher body and the rolls churn it (increasing wear). If the concentration is too high, the crusher can stall.

Some material, such as pieces of slag or erection debris can be difficult for the crusher to break. They can stop the clinker grinder. Excessively packed material can also stop the clinker grinder. If the clinker grinder has an automatic rotation sensor, it should automatically reverse a predetermined number of times to clear the stoppage. If the system does not have automatic reversal, manually alternate the clinker grinder between reverse and forward operation to try to clear the obstruction. If this is ineffective, the obstruction must be cleared manually.

The shaft seal must not be over-tightened. It may act as a brake on the shaft and cause overheating, or even stall the crusher.

The crusher stops if any control interlock opens during operation. The most common causes are low pressure at either the jet pump nozzle, low seal water pressure, sluice gate not completely open, or crusher rotation sensor. Check the annunciators for malfunction and correct the condition.

Some grinder rolls can be rebuilt by welding, using a hard-surface welding rod.

Jet Pump

Jet pump(s) should be inspected for wear in the body, throat section (combining tube) and nozzle. Replace parts that are worn.

Guaranteed (design) capacity of a jet pump is defined as the ash conveying rate calculated on the basis of an allowable degree of wear in the jet pump (throat section). Hence the design wear of the throat section should be listed in the instruction manual. Due to this, actual ash conveying rate of a jet pump is initially greater (when new) than the guaranteed capacity and then decreases to the guaranteed capacity as the jet pump wears. Replace the throat section when it is worn to the specified maximum amount.

When the throat section is worn to the diameter specified by the system supplier as the worn condition, the pressure in the sluice line should be measured at a point downstream from the jet pump that is free from turbulence induced by fittings, at a time when the conveyor has a normal ash loading. This pressure should be recorded for reference. After changing the throat section of the jet pump, periodically measure the pressure at the same point in the conveyor line as the reference pressure. When the pressure drops to the reference pressure, inspect the combining tube for wear.

For guaranteed (design) capacity, the jet pump nozzle should be supplied water at the design pressure. Capacity of a jet pump will reduce if the nozzle water pressure is reduced. The nozzle water pressure may reduce if the discharge pressure of the sluice/ash water pumps is low (due to wear of pump parts, hole in the column pipe of the pump in case of vertical pumps, pump rotating in the reverse direction or struck/defective non return valve of the stand by pump). Water pressure to the jet pump is normally reduced as the nozzle wears and allows the flow through the nozzle to increase. Hence regularly inspect the nozzle for wear and replace it if it is worn more than the design diameter.

Mostly sluice/ash water pumps are supplying water to jet pumps and hopper's internal nozzles. In such case, water pressure to the jet pump can be reduced by wear of the orifices used to control the water flow to the hopper's internal nozzles. When internal nozzles are in use, the increased flow to them will reduce the water flow and pressure to the jet pump.

There is a distinct difference between slow feed to the jet pump and low capacity. Slow feed occurs during the initial emptying of a hopper section (having extremely dense mixture of ash and water) and can improve as the section empties. Low capacity refers to reduction in the rate at which ash is conveyed and remains consistent during the entire hopper emptying operation. If the ash feed to the jet pump is slow, the cause may be the concentration of ash in the slurry. The jet pump requires a specific concentration of ash to operate correctly. The inlet suction of a jet pump decreases as the resistance head increases. A high concentration of ash in the slurry increases the resistance head in the conveyor line. The reduced suction head reduces the amount of ash that the pump accepts at the inlet. To overcome the problem, use of a diluting spray pipe in the feed gate housing is recommended for diluting the ash flow to acceptable level by the jet pump.

The nature of the ash affects the service life of the jet pump. If the service life is unsatisfactory, the system supplier should be contacted for information on the availability of parts manufactured from a more abrasion resistant alloy or manufactured with an abrasion resistant lining to minimize the frequency of part replacement.

Wear on the crusher rolls reduces the engagement between the elements used to reduce the material to the required size. The reduction of the engagement of the elements leads to an increase in the size of the particles discharged from the crusher. This can cause the jet pump used to transport the material to plug.

Dewatering Bin

Carry over is a function of turbulence in the dewatering bin and the velocity of the incoming water as it travels from the entry point to the overflow weir. The bin design should balance the water quantity and the bin diameter to limit velocity to a maximum acceptable rate. The turbulence prevents smaller ash particles from dropping out of suspension and settling. If carry over into the drain pipe during the dewatering process is excessive, it may be due to insufficient time for the ash to settle before dewatering. Some time is required before dewatering begins to allow as many of the ash particles as possible to settle into the bin.

The dewatering rate can be reduced by any ash accumulation at the surface of the screens. Ash at the surface of the screens serves as a filter to retain smaller particles and keep them from passing into the dewatering screens. The dewatering rate is set for normal conditions. If the ash is fine and the dewatering flow is high, the combination can pack the ash at the screens and reduce the water flow. Inspect the orifices in the dewatering pipe for wear. If they are worn and oversized, replace them with orifices of the correct size. If the orifices are of the correct specified size, contact the system supplier for recommendations on changing the orifices.

During emptying, fine ash can pack if it is dewatered too rapidly. Packing can also occur if fine ash sits too long between dewatering and emptying resulting in emptying problems. In some cases, allowing a small amount of water to remain in the ash helps the ash to empty, if some additional moisture can be tolerated during the initial emptying. The correct amount of moisture must be determined by experiment. Ash having high calcium content can solidify from the chemical reactions of the calcium compounds mixed with water. Therefore, the interval between dewatering and emptying of the bin should be minimized.

Ash can accumulate on the metallic bin walls. While the bin is emptying, it may be necessary to use a vibrator to remove the ash from the walls. However, the vibrator must be used with care. If ash is fine and flowing freely, a vibrator can pack it and stop the flow. Use the vibrators only if required and only at the end of the operation to remove residual ash from the walls.

The screens in the dewatering elements can be partially plugged by the ash that hardens on the surface or a mineral accumulation. This reduces the dewatering rate. If the screens are plugged, they must be cleaned. The screens can be cleaned by back-flushing them. The reverse flow may remove some of the ash and/or mineral deposits.

If material that is plugging the screens cannot be removed by back-flushing, remove the screens for cleaning. As most screens are fabricated from stainless steel, they can be cleaned either manually or by using an acid bath. In selecting an acid cleaner, such as hydrochloric acid, be sure that the solution used does not attack the screen material.

Corrosion

In general, if there is corrosion, and the hopper water pH is less than 5.5, it may be necessary to use a corrosion-resistant material for the corroding parts of ash hopper, discharge gate, clinker grinder, jet pump and dewatering bin.

Hydraulic/slucice Conveyor Lines

There are two major problems with hydraulic/slucice conveyor lines: line plugs and line wear.

Conveyor Line Plugs

In normal operation, the discharge from a hydraulic/slucice system is nearly constant. If the discharge has an intermittent spurting pattern, it indicates a pressure buildup that intermittently forces material past an obstruction in the line. Hence, it is likely that there is a plug in the line.

Heavy particles, such as pyrites, can fall out of suspension in vertical or angled risers. To prevent development of obstructions, the conveyor line must be flushed after each operation. If the line is not flushed to remove all the ash that has dropped out of suspension during conveying, the resulting accumulations can form a base for additional material that drops out of suspension during succeeding operations. This can result in a partial or complete plug developing in the line.

It is recommended that the conveyor line must be flushed for at least twice as long as the time required for ash to travel from the bottom ash hopper to the discharge point. This period (seconds) equals the quotient of the conveyor line length (feet) divided by the minimum conveying velocity (feet per second). Generally, the conveying velocity is from 5 to 7.5 feet per second. The lower value should be used so as to have a conservative value for the duration of the flush.

When coal that has a high calcium content is burned, the calcium oxide in the ash can mix with water and carbon dioxide in the air to form calcium carbonate, or limestone. This tends to accumulate on the walls of the pipe, which reduces the effective diameter of the pipe. Eventually, this causes the equivalent of a pipe plug, which reduces system capacity. The calcium accumulation must be removed by either an acid flush or a mechanical pipe cleaning device.

If ash is having a high calcium content and there is a common discharge line for fly ash and bottom ash, it is recommended to convey the fly ash first, followed by the bottom ash and pyrites. This helps to scour some of the lime before it hardens. If the line is used only for fly ash, it may be necessary to use a mechanical pipe cleaning device.

Conveyor Line Wear

Because ash is normally conveyed along the bottom of the conveyor pipe, a wear pattern develops in the lower quadrant of the pipe. Regular inspection of the pipe makes it possible to determine when there is appreciable wear. Periodically rotating the pipe in increments of 90 to 120 degrees increases the effective life of the pipe.

Ash handling systems are forgiving in the short term, but if sufficient leaks and wear occur, conveying capacity is quickly impaired. A leaky/worn system has reduced capacity and must be run longer to empty the hoppers/silo and convey all the ash. In the extreme case, the system will be run continuously leading to breakdown.

Line Leaks

Anchors are required to prevent the connections in the fixed portions of the conveyor line from being pulled apart by expansion or contraction of the conveyor line. Guides are required to prevent the conveyor line from moving laterally, which would put a toggling force on the connections in the fixed portions of the line. Expansion joints are used to accommodate movement in the conveyor line.

If pipe connections fail at elbows and cause leakage, it indicates that the elbows are not properly anchored. The anchors must be able to withstand the force imparted to the conveyor line. Modify the anchors to withstand the forces if they are not designed to do so.

In some climates, the water in the pipeline can freeze during cold weather, which damages both the connections and the pipe. To prevent freezing, the pipeline should be constructed with provisions for draining the water. Alternatively, a continuous flow of water through the line can be used to prevent freezing in most cases.

Pneumatic Conveyor Lines

Pneumatic conveying systems are used to handle fly ash in dry form. Both positive and negative pressure systems are used. The conveying distance may be small in case of evacuation of ash from a multitude of storage hoppers like the ESP hoppers into an intermediate hopper. The conveying distance can, however, be much longer from the intermediate hoppers to the disposal silos.

The design of pneumatic conveying system involves consideration of many complex variables. Despite being simple in concept, pneumatic conveying systems present significant design problems, not only because of the fact that the conveying medium is compressible. The properties of the material to be conveyed also have a very significant influence on both the design of systems and the specification of components. For example, it is reasonably established that different grades of ash can have entirely different behavior in the pipeline. While the ESP ash can be successfully conveyed in non-suspension flow at very low conveying line inlet air velocity, the ash collected in the economizer hoppers can only be conveyed in dilute phase suspension flow.

Most designs are generally based on the use of existing data for the material to be conveyed, and if such data is not available it is usually generated by actually conveying a large sample of the material in a pneumatic conveying test rigs/facility. As the design process is entirely empirically based, problems do arise in the operation of these systems. The inability to convey a material, frequent pipeline blockages and systems not capable of meeting the required duty are some of the major problems.

Pipeline Blockage

The inability to convey a material, systems not capable of meeting the required duty and pipeline blockages could be due to system components (plant items), such as the feeding device, or it may be a material related problem, such as particle size or the prevailing weather conditions, such as ambient temperature. Following table lists possible causes of pipeline blockage due to plant items and actions to be taken. A brief explanation is also given for some the items after the table.

Plant Item	Possible Cause / Action Required
Air Mover	Incorrect Specification: Check delivery air pressure and quantity (if quantity of air delivered is less, conveying line inlet air velocity may not be adequate).
	Relief Valve Setting: Correct the setting if it is too low resulting in low pressure.
	Low Ambient Temperature: Check temperature of the inlet air. If the inlet air temperature is low, conveying line inlet air velocity may be inadequate.
	Inlet Filter: Check that it is clean
	Wear: Air movers rating (for example, pressure) may deteriorate to unacceptable clearance.
Air Supply Line	Flow Restriction: Check opening of valves.
Feeder	Over Feeding: In case of rotary feeder, reduce speed to lower the feeding rate. In case of blow tanks and suction nozzles, change proportion of air flow.
	Wear: Check clearance.
Pipeline (Conveyor)	Blocked Pipeline: Ensure that pipeline is thoroughly purged before commencement of conveying.
	Air Leakages: Check for holes or cracks in piping and leakage at joints.
	Condensation in Pipeline: Purge the line with air until dry.
	Oversized or Wet Material: Check quality of the material.
Reception	Already Full: Interlocking permissive may not allow to start conveying.
System	Change of Material or Distance: Check required pressure, required air, feed rate, etc. for the new condition.

Incorrect Air Mover Specification

If the volumetric flow rate of air and pressure available for conveying the material in the pipeline is insufficient, it is unlikely that it will be possible to convey the material. A certain minimum value of conveying air velocity must be maintained at the material pickup point at the start of the conveying line. The value depends upon the material being conveyed and conveying method (dilute phase, dense phase, etc.).

Cold Air

On start up the air will initially be fairly cold for conveying the material, resulting in lower conveying line inlet air velocity. If the conveying air velocity is below that necessary to transport the material, the pipeline could block. Since air density increases with decrease in temperature, it is essential that air requirements are based on the lowest temperature (cold start up in winter) that is likely to be experienced.

Air Filters

If a blower, or any other positive displacement air mover is operating in a dusty environment, an air filter should be fitted to the air inlet. This filter should be cleaned or changed periodically, because if it becomes choked with dust, the added resistance will have an adverse effect on the blower performance. A source of air away from the plant or outside the building is generally recommended in these circumstances. Similarly, in a negative pressure

system, air which has been used for conveying material should be effectively filtered before it enters the blower/exhauster.

If a gradual change in performance of a pneumatic conveying system is observed over a period of time, it could be due to wear of the blower. Ingress of dusty air into the blower will cause a gradual change in its operating characteristics.

Over Feeding of Pipeline

The pressure drop in the conveying line is primarily dependent upon the concentration of the material in the pipeline, or the solids loading ratio. If too much material is fed into the conveying line it is possible that the pipeline could become blocked because the pressure required may exceed the capability of the air mover. In such case, it will be necessary to reduce the material feed rate to match the capability of the air mover.

Feeder Wear

Most manufacturers of rotary valve feeders provide data on air leakage across their rotary valves so that this can be taken into account in the specification of air requirements for air movers. If there is wear, because of handling an abrasive material, blade tip clearances will increase, and there will be an increase in air leakage. If the air leakage increases, less air will be available to convey the material. If the leakage is such that it results in the conveying air velocity falling below the minimum value, the pipeline will block.

Material in Pipeline

If, when the plant is shut down, the pipeline is not purged, a quantity of material could be left in the pipeline. If the conveying line incorporates a long vertical lift section, sufficient material could accumulate in the bend at the bottom to prevent the system from being re-started. It is always a wise precaution on start up to blow air through the pipeline before material is introduced. If the pipeline was not purged on shut down, there may be sufficient material left in the pipeline to cause blockage of the pipeline during start up. If the pipeline is already blocked it will considerably aggravate the situation if more material is blown into the pipeline.

If conveying stops unexpectedly due, for example, to a power supply failure, it may not be possible to start the system again, particularly if the pipeline incorporates a large vertical lift. If the bends at the bottom of any vertical sections are taken out, to remove the material at these points, it may be possible to purge the line clear, if the pipeline is not too long.

Alternatively, a parallel line with connecting valves to the pipeline could be fitted so that the pipeline could be cleared slowly from the end, one section at a time.

Moisture in Line

If material is blown into a cold pipeline, it is possible that the inside surface of a cold pipeline could be wet as a result of condensation. This is liable to occur in pipelines which are subject to large temperature variations, particularly where the pipe runs outside buildings.

If the inside surface of a pipeline is wet, as a result of condensation, fine material will tend to stick to the wall surface. This is particularly a problem at bends prior to a vertical lift. Moisture condensing on the surface of the vertical pipeline will tend to drain down to the bend at the bottom and collect as a pool of water. It depends upon the nature of the material being conveyed, and its interaction with water, as to what will happen when the material meets the water. In some cases, a hard scale will form, and this will gradually accumulate

with successive cycles of condensation and conveying, to a point where the buildup adds significantly to the pipeline resistance. For a conveying system operating close to its pressure limit, the added resistance could result in pipeline blockage.

The problem could be overcome by blowing the conveying air through the pipeline for a period to dry it out prior to introducing the material.

In general moisture is often a problem in high pressure plant air supplies. In view of this, if plant air is used, it would be wise to incorporate a moisture separating device.

Change of Distance

If a blow tank is to be used to convey a material over a range of distances, it will be necessary to change the proportion of the air according to the distance conveyed. If this is not done the pipeline will be underutilized for shorter distances, and may block on longer distances.

If a system operates satisfactorily in conveying a material over a given distance, it is quite possible that the pipeline will block if the pipeline is extended and to convey the material over a longer distance. A change of pipeline routing that requires an increase in the number of bends in the pipeline can also affect performance. Even a change of existing bends in a pipeline, to bends having a different geometry for example, can influence the performance.

Vacuum Breaker for Water-powered Exhauster (Vacuum Producer)

If a water-powered vacuum producer is used, moisture can enter the conveyor line during shut-down. Unless there is an open connection to the atmosphere from the vacuum producer, droplets of moisture can be drawn from the vacuum producer to the conveyor-line section that is under high vacuum.

In view of above a vacuum breaker is installed immediately upstream of the water-powered vacuum producer. Adjust the breaker to open before the water-supply valve to the water-powered vacuum producer is closed.

Pipeline Wear

If the hardness of the particles to be conveyed is higher than that of the pipeline components, such as pipeline bends, then erosive wear will occur at all surfaces against which the particles impact. Erosion is the wear caused by the impact of particles against surfaces, and the angle of impact is a major variable in the wear process. Abrasive wear is caused by the sliding of particles against retaining surfaces. Abrasive wear can be a problem with hoppers, chutes, etc. In pneumatic conveying, erosive wear can be a severe problem because of the high velocities required to convey bulk particulate materials.

Influence of Velocity

Conveying air velocity is a major factor for erosive wear. It is recognized that erosive wear is dependent upon a simple power of velocity, such as: $Erosion = constant \times (velocity)^n$. The values of n range from 2 to 6 (n is generally considered to be approximately 2.5). Hence any reduction that can be made in the velocity at which the material is conveyed will help to reduce the erosive wear. Since the conveying air velocity increases along the length of a pipeline (because air is compressible, with reduction of pressure along the length of a pipeline, air volume and hence air velocity increases), the bends at the end of the pipeline are likely to fail first. Hence, erosion could be reduced by increasing the pipeline bore over

the last part of the pipeline. Use of stepped pipelines to achieve a lower velocity profile is an accepted practice.

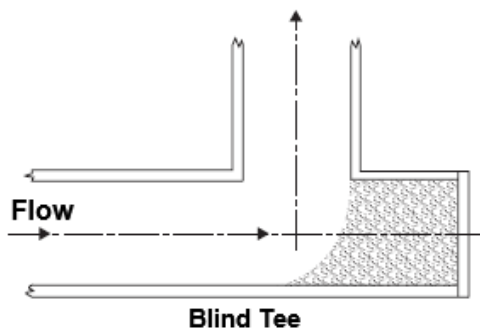

A variety of solutions are possible for the bend erosion problem. Use of a blind tee bend, shown in above figure will provide a cheap and effective solution to the problem. It will probably last many times longer than an equivalent radiused bend. It will ultimately fail around the inside corner due to turbulence. The blind end of the bend traps the conveyed material and so the oncoming material impacts against other material, instead of the bend, and thereby protects it. This is similar to the 'rock/dirt box' used in many areas of bulk solids handling where surfaces have to be protected from sliding and impacting abrasive materials.

The penalty, however, is in the increased pressure drop that can result. Hence, consideration should be given to the possible increase in pressure drop, which can be very marked, particularly if there are several of them in a pipeline. The straight section of pipeline immediately following a blind tee bend should be reinforced, because it will suffer impact wear as a result of the turbulence generated by such an abrupt change in direction.

Another problem with this type of bend is that the material that is trapped in the dead end of the bend may take a long time to be purged from the bend at the end of a conveying run. It could not, therefore, be used in pipelines required for the conveying of perishable and other time limited materials.

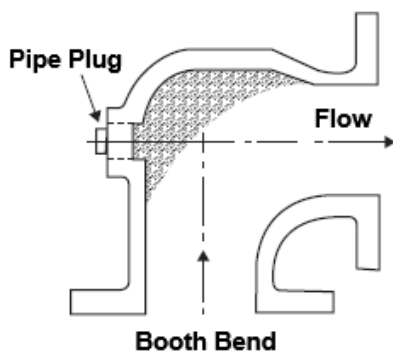

Number of bends have been developed, specifically for pneumatic conveying system pipelines, which have neither constant bore nor constant radius. Above figure shows one of them, a more sophisticated version of the blind tee bend. It was developed in the early 1970s and is known as the Booth bend after its originator. It is a very short radius cast bend that incorporates a shallow depression. This allows material to collect in the bend and so subsequent material flowing through the pipeline will impact against itself. At the end of a conveying cycle the trapped material will be readily purged from the shallow depression in this bend. A pipe plug is also provided in the back of the bend to remove blockage at the bend.

Wear of Straight Pipeline

Straight pipeline is rarely a problem with regard to erosive wear, although there are specific circumstances where it should be taken into account.

To extend the life of the pipeline following a bend, it is suggested that a short section of thick walled pipe should be placed between the bend and the main pipeline. Since the flow of deflected particles issuing from a bend will generally impinge constantly on the same area of the thick walled pipe it is also recommended that this short section of pipe should be connected by flanges to the bend and the following section of regular pipeline so that it can be rotated on a regular basis.

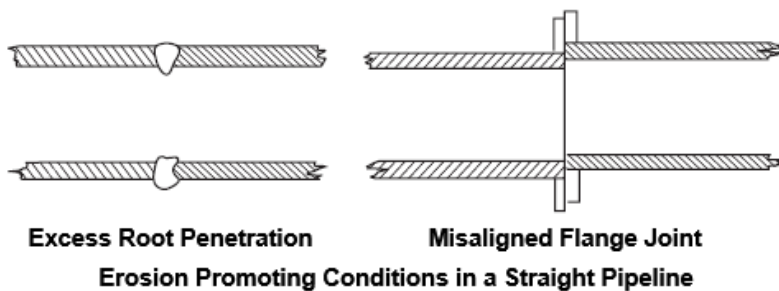

Erosion promoting conditions like welded joints with excess root penetration (weld metal protruding inside the pipeline) and misaligned flange joints as shown in above figure could cause turbulence or deflecting flows and can often lead to failure in a straight pipeline, particularly in small bore pipelines. To avoid erosion due to turbulence or deflecting flows, flange face shall be at right angle to pipe axis and gasket should not project inside the flange.

Hard Materials

Hard brittle materials are generally used in cases of severe erosive wear. Materials used include Ni-hard, basalt and ceramics. Ni-hard is an abrasion resistant white cast iron. It contains about 6% Ni, 8.5% Cr, 1.7% Si and 0.5% Mn and the structure can be refined by chill casting. The material has a Brinell hardness of 550 to 650, which is equivalent to a Vickers hardness of about 750 kg/mm².

Basalt is a volcanic rock which can be cast into sections and used for lining surfaces, and although widely used for lining chutes and hoppers, it is often used for straight pipeline and bends. After casting, the material is heat treated to transform it from an amorphous into a crystalline structure. This is a naturally hard material with a hardness, according to the Mohs' scale of 8, which is equivalent to a Vickers hardness of about 720 kg/mm². Basalt consists of approximately 45% silica and 15% alumina, with the rest made up of oxides of iron, calcium, magnesium, potassium, sodium and titanium.

Of the materials used for providing erosion resistance, alumina based materials are probably most common. A typical material consists of 50% aluminium oxide, 33% zirconium oxide and 16% silicon oxide. The general industry specification today is an alumina content of 85%, although higher alumina contents can be supplied. It has a hardness of 9 on the Mohs' scale, which is equivalent a Vickers hardness of about 2000 kg/mm². Like basalt, these materials can also be cast into the required shape.

A wide range of materials can be applied to existing surfaces. In many cases they are even applied to erosion resistant surfaces, to give added protection. Hard facing metal alloys (e.g. tungsten carbide), can be applied to surfaces by means of flame spray coating.

It may be noted that thick-wall pipe of a hard alloy (Ni-hard) can break if it is used in a system with very high ash temperatures. Ash is conveyed in the lower part of the pipe, which becomes hotter than the top of the pipe. This causes the pipe to bow due to differential expansion. Because the hard alloys are brittle, the pipe cannot bend sufficiently to accommodate the differential expansion if the temperature difference becomes great. In such a case, the pipe often breaks.

Hard Materials Filled Epoxy Wear Coatings

To protect piping and material handling equipment from abrasion and wear, they may be coated with hard materials filled epoxy compounds. Many companies are selling such compounds. For example, KALOCER® TWC ceramic filled epoxy wear coating and repair compound by Abresist Kalenborn Corporation (website address: www.abresist.com) is one such compound. KALOCER® TWC is a two-part trowelable epoxy repair compound containing 50% by volume sapphire hard (9 Mohs) alumina ceramic beads (Al_2O_3) and silicon carbide particles. Belzona International Limited (website address: www.belzona.com) are selling ceramic carbide based compounds as Belzona® 1811/1812 (Ceramic Carbide).

System Operation and Leakage

If an ash system is operated continuously, the ash loading in the conveyor decreases and the velocity at which the ash is conveyed increases leading to increase in the wear of the conveyor. In view of this, if possible, the system should be operated intermittently.

Similarly, leakage in the system reduces the ash loading in the conveyor line, increases the conveying velocity, and increased wear. Check for holes or cracks in the piping and leakage at the joints and attend them.

Troubleshooting Vacuum Fly Ash System

Troubleshooting a vacuum fly ash system begins with a review of the vacuum chart. With training and experience, the operator can use a vacuum chart to determine the status of system operation. The vacuum chart also provides indications of problems.

There are two basic types of vacuum systems: cycling and non-cycling feed.

Following figure shows a trace of vacuum vs. time for a normal cycling feed system.

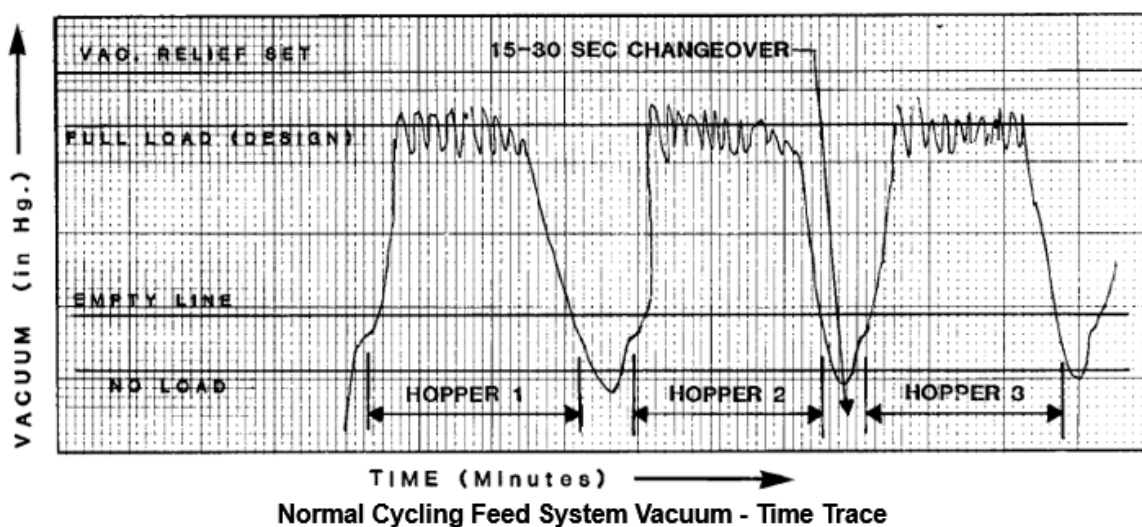

A cycling feed system (United Conveyor Corporation and most other manufacturers) uses a vacuum switch set at the vacuum (VAC. RELIEF SET) that is calculated to interrupt ash feed by closing the ash intake whenever the system vacuum exceeds this set point. The cycling system requires an ash intake that can react quickly to the commands initiated by the vacuum switches that monitor system vacuum. The ash intake in this type of system typically uses a swing-disc gate. While the design of the inlet and outlet components can vary, a swing-disc gate is the common item in different brands of intakes for cycling systems.

Following figure shows a trace of vacuum vs. time for a non-cycling feed system.

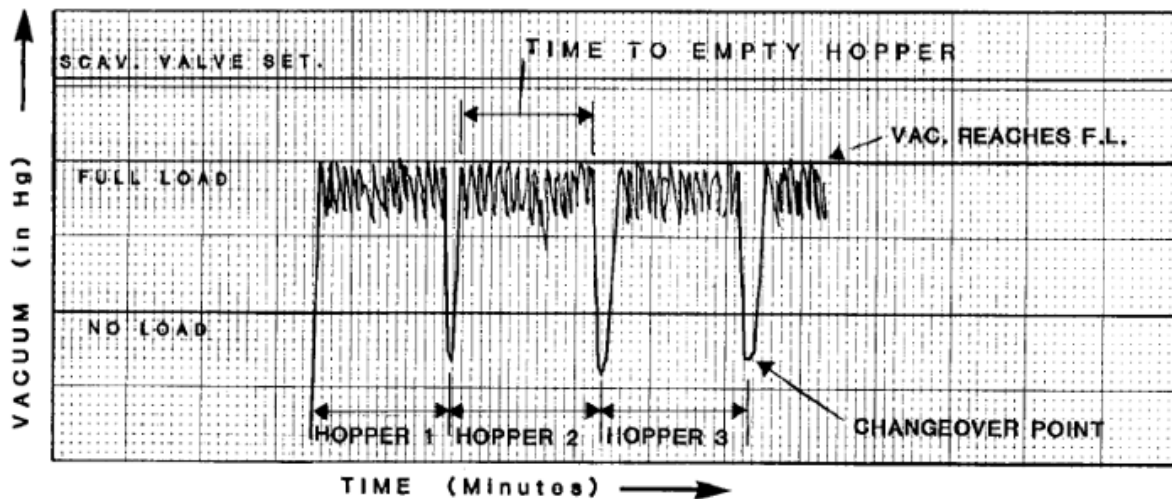

Normal Non-Cycling Feed System (Allen Sherman Hoff Company) Vacuum - Time Trace

Non-cycling feed system (typical of Allen Sherman Hoff Company) does not close the ash intake to prevent system overload. Instead, it admits atmospheric air, which dilutes the overloading “slug” of ash, and also reduces the feed of ash from the intake. The atmospheric air - partially or completely - satisfies the exhauster. This air is admitted through a pair of spring-loaded poppet check valves, which are part of the intake assembly, through a check valve at the inlet end of each branch line.

Sometime the air also passes through a “scavenger” valve downstream of the intakes. A scavenger valve limits conveyor line loading beyond its conveying capacity (where ash drops out of suspension) which can lead to plugging the line. If the scavenger valve fails to open on high vacuum, the ash loading can exceed the conveying capacity of the system, and ash can drop out of suspension to create a line plug. The scavenger valve can fail to open if there is an actuator malfunction, a solenoid valve malfunction, or low air pressure.

As shown in above figure, in a non-cyclic normal system (without any problem in the system), the vacuum rises to the point at which the poppet-type check valves in the ash intake open. This adds conveying air to the system, reduces the amount of ash in the conveying stream, and causes the vacuum to drop. When the vacuum drops to the point at which the check valves close, the amount of ash in the conveying stream increases and the vacuum rises until the check valves reopen. This cycle continues until the hopper is empty. The vacuum then drops to the no-load vacuum switch setting, and the system advances to the next step in the operating sequence.

A knife gate can be used in a non-cycling feed system ash intake, since it simply opens at the beginning of the hopper emptying cycle and closes at the end of the cycle. Thus, the knife gate is not required to cut through the flow of ash from the hopper to stop it for overload regulation.

Both cycling and non-cycling systems require a vacuum producer. One type is a water-powered unit that uses a venturi section to induce the vacuum. This can serve either simply as a vacuum producer, or also be utilized to slurry the ash for discharge to a fill area or an ash pond. Alternatively, either a positive-displacement blower or a water-seal vacuum pump can be used to produce a vacuum.

For a vacuum chart to provide accurate indicators of conditions, a set of reference vacuums is required. These must be measured when the system is either new or "equal to new" - that is, when the vacuum producer is either new or equal to new in a system with minimal leakage.

Troubleshooting Non-Cycling Feed System

In a non-cycling feed system (typical of Allen Sherman Hoff Company), the following three vacuum reference points should be recorded.

- Isolated Vacuum Producer
- Closed-Line Vacuum
- Empty-Hopper Vacuum

The vacuum produced by the Isolated Vacuum Producer is measured after a blank flange is inserted in a pipe connection upstream from the vacuum producer. If the vacuum producer is a mechanical unit, the blank must be upstream from the vacuum-relief valve to protect the unit. The vacuum is measured while the vacuum producer is operating, using a mercury manometer attached to its inlet.

If a water-powered vacuum producer is used, the isolated vacuum is the maximum that the unit can produce. If a mechanical vacuum producer is used, the vacuum equals the setting of the vacuum-relief valve.

To measure the Closed-Line Vacuum, ash intakes and the scavenger valve must be closed. The air-inlet check valves at the end of each branch line must be replaced with a fitting to which a manometer can be connected. The values of the vacuum should be read simultaneously at the end of the selected branch line and at the inlet of the vacuum producer, and recorded. A closed-line reading should be made for each branch line.

Compare the vacuums recorded at the vacuum producer and at the air intake. The difference between the two values is determined by the amount of air that enters the conveyor line between the air intake of the branch line and the vacuum producer. If this difference is less than 1.0 in. Hg, the conveyor and branch line can be considered satisfactorily tight. If the difference is from 1.0 to 2.5 in. Hg, it means that there is a leakage problem that requires attention. The greater the difference, the greater the need for attention. If the difference exceeds 2.5 in. Hg, the leakage problem requires immediate attention.

The Empty-Hopper Vacuum is an indicator of an empty hopper. This is the vacuum produced when the hopper farthest from the vacuum producer is empty. This vacuum is the highest value for empty-hopper vacuum in the system, and will be applicable to all hoppers.

The full load or design vacuum switch should be set to the vacuum stated in the system instructions. The empty hopper change-over vacuum switch should be set as directed by the system instructions.

Being able to interpret vacuum charts can save an appreciable amount of time in identifying problems and malfunctions that can occur in a vacuum system. The following is a set of typical vacuum-chart traces and descriptions of the conditions they indicate in a non-cyclic (Allen Sherman Hoff Company) feed system.

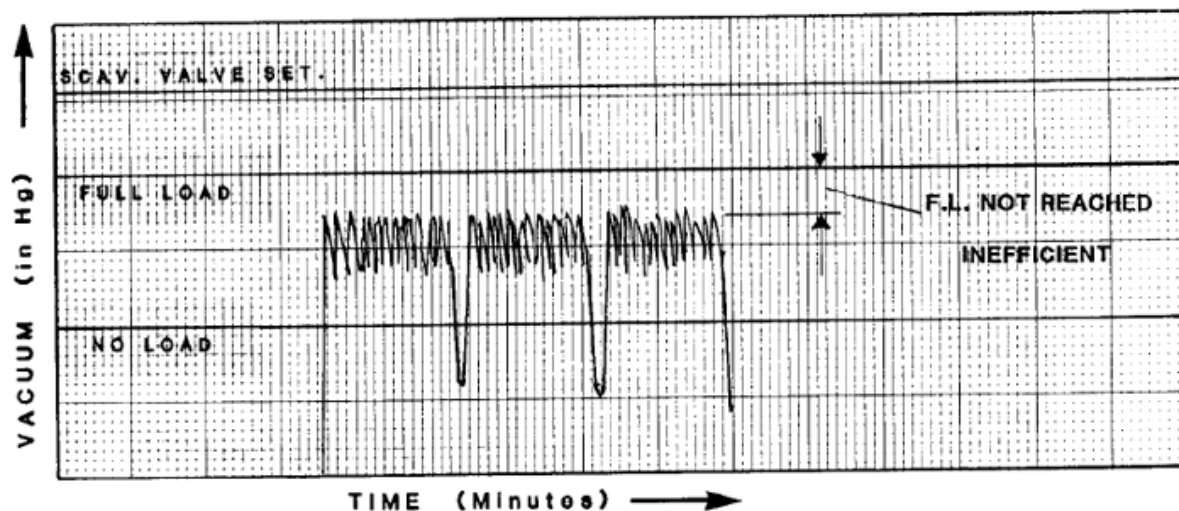

Lower Vacuum, Indicative of Leakage or Feed Problem [Non-cyclic (A. S. H.) Feed System]

If there is major leakage into the system, as shown in above figure, the vacuum may not rise to the point at which the check valves will open. The leaks in the system reduce the amount of ash that can be conveyed, causing the vacuum to be below normal.

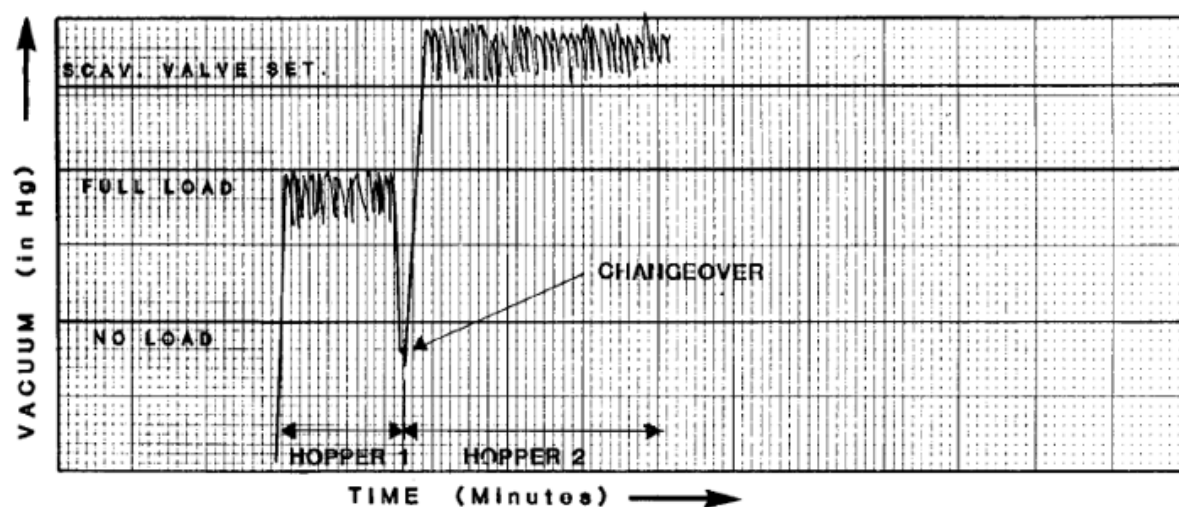

Change-over to Plugged Hopper or Plugged Branch [Non-cyclic (A. S. H.) Feed System]

As shown in above figure, normal operation on one hopper followed by increase to the scavenger-valve setting on the next hopper indicates plugging in the second hopper.

If the vacuum increases to the scavenger-valve setting after a branch-line changeover, it can indicate any one of several conditions: the gate on the next branch line has failed in the closed position; the hopper has plugged completely, preventing flue gas from passing through the hopper; or there may be a plugged conveyor line. Any of these problems would prevent sufficient air and/or flue gas from reaching the vacuum producer to satisfy its input requirements, and thereby cause vacuum to increase to the scavenger-valve setting.

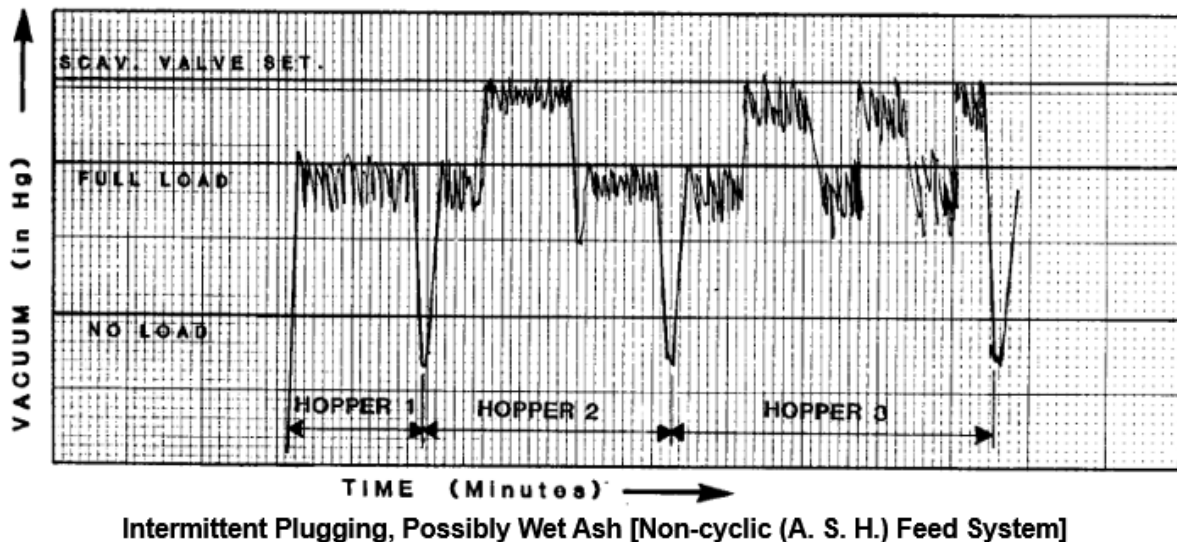

Above figure illustrates intermittent increases of vacuum to the scavenger-valve setting, which can indicate that a line is plugging intermittently. This can be caused whenever ash accumulates in the line, forming a plug, which then erodes enough to allow operation to resume.

Interpretation of vacuum charts for cycling feed system (United Conveyor Corporation and most other manufacturers) can be carried out in a similar manner. For detailed information on it, please see "In-Plant Ash-Handling Reference Manual", CS-4880, Research Project 1835-4 (Final Report, January 1987) by Electric Power Research Institute, 3412 Hillview Avenue, Palo Alto, California 94304.

Ash Conveying Piping Problems and Solutions

Problems with ash conveyor piping result from improper design or specification, fuel switching and hence ash changes after installation, unexpected high-wear areas, or unacceptable maintenance levels. If unacceptable wear or failure is occurring, the options for solution are proper repair, reconfiguring the problem area, or replace with different materials or equipment. For example, a user finding one particular elbow requiring too frequent replacement may install one of, harder material, or different design, such as with a replaceable wearback or longer radius.

Once the system has been in operation, it may be determined that a harder (and more expensive) material will provide a significantly longer life in a specific location, to justify its replacement.

If pipe wears at an unacceptable rate, the use of a pipe lined with ceramic or basalt, or some other abrasion-resistant material, may increase the service life.

With basalt lined sluice pipe, it may be possible to extend the life of the pipe to the life of the plant, usually 30 years.

The specification and use of premium materials almost always pays for itself. The problem is that most users do not know what is available, and most vendors routinely offer their own "standard" material.

Maintenance of Dome Valves

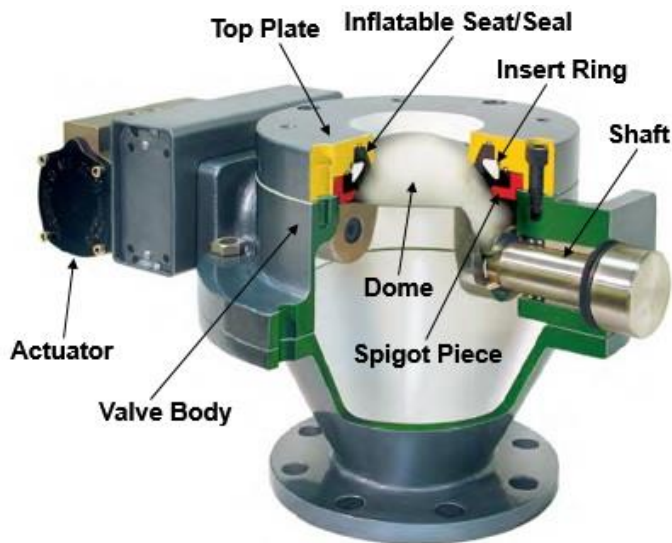

Typical Dome Valve Construction

Ensure the following during assembly of a dome valve for a long and trouble free operation.

For 100% closure of the valve, dome should be kept at the center of the top plate. For centering the dome; dome, top plate and valve body are generally marked with center line along the axis of the shaft as well as across the axis of the shaft. In case the center lines are not marked/legible, mark them locally.

In case of a pneumatically operated valve, the valve may not close 100% if the air cylinder is not taking full stroke. In case the air cylinder is not taking full stroke, you may loosen the cushioning screw of air cylinder and then adjust it so that it takes the full stroke.

Another reason for dome not closing 100% could be that the screw of cylinder mounting bracket may be loose.

Material passing during conveying due to valve not closing fully will result in premature failure of dome valve seat and dome. It is recommended to mark match lines on spindle and valve body and periodically monitor their position to ensure that the valve is closing fully.

Check the gap between the dome and inflatable seal. The average gap should be around 0.5 mm (or as recommended by dome valve manufacturer).

Caution:

For water cooled dome valves, water supply should be checked periodically (everyday) to avoid seal failure. In case of inflatable seat/seal failure, immediate action should be taken. Continuing operation with the damaged seat will damage the dome also.

Air Cylinder (Pneumatic Actuator)

Internal leakage in the air cylinder can cause the actuator to be unable to overcome the resistance of the valve. In this event, there is a flow of air past the piston seal.

Air pressure below the specified minimum reduces the force developed by the air cylinder. The force may then be inadequate to overcome the force of the valve to open it.

Totally dry air increases the friction between the cylinder and the piston, and can also affect the resiliency of the piston seal. This shortens the life of the seal and causes internal leakage in the air cylinder. If the compressed air is dried, a lubricator should be used on the air supply line to the air cylinder(s).

A corroded or pitted piston rod can damage the rod-end packing of the air cylinder and cause leakage along the rod.

Conveyor Line Vibrator

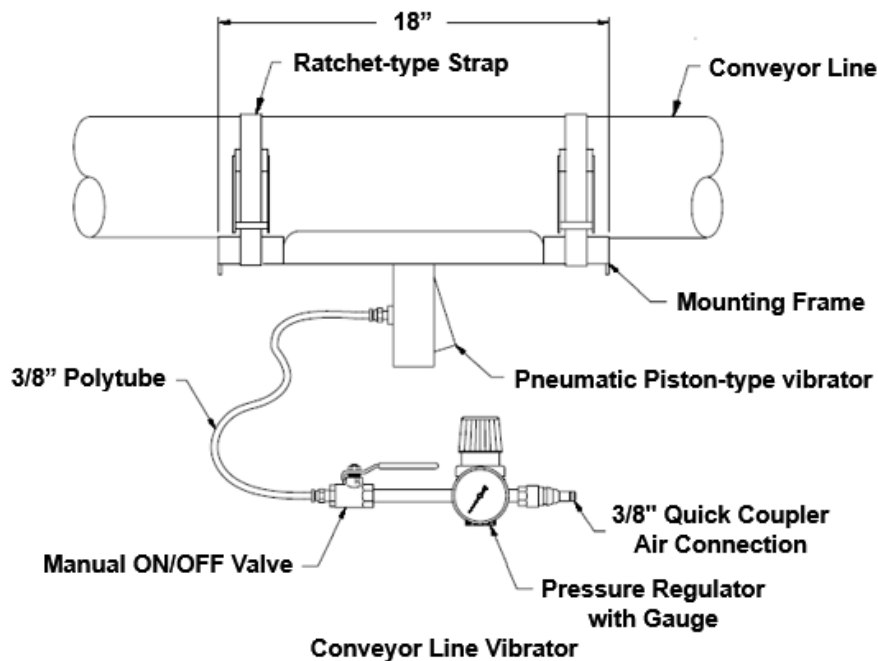

Above figure shows NOL-TEC conveyor line vibrator (Model 398), which may be used to dislodge conveyor line (minimum pipe size = 3") plugs in a dense phase pneumatic conveying system. It uses ratchet-type straps for quick mounting to the conveyor line. For more information on the vibrator, please contact Nol-Tec Systems, Inc. (website address: www.nol-tec.com)

Field Cutting of Basalt Lined Pipe

Cast basalt lined steel pipe can be modified/cut in the field using the following procedure.



As shown in above figure, place the pipe to be cut on three timbers. Choose timbers of sufficient thickness to clear flanges of the ground or floor.



Care should be taken in marking the pipe for the cut to assure a good square end. Measure and mark the pipe at 6 to 8 places around the circumference and join these lines rather than using a wrap-around from a single point.



Arrange the timbers as shown in above figure. Place one timber near the flanged end. Place the other two timbers so that they will straddle the cut. Before beginning to cut, roll the pipe a full 360° to assure that the pipe is in contact with the timbers at all positions to prevent premature fracture of the lining.

The initial cut with the abrasive cut-off saw should be done with care to insure a good square end. Cut through the steel casing/shell and cement mortar/filler before attempting to cut the basalt lining. The steel casing and cement mortar beneath the steel will be relatively easy to cut. You will feel a hard surface under the cement, which will be the basalt liner.



Cutting of the basalt liner should be done while continually rotating the pipe on the timbers. Let the abrasive blade “score” the basalt liner. Do not pressure the blade or stay in one spot. If one area is penetrated more than another, there is a good chance of an uneven break.



After penetrating the basalt liner 1/4" to 3/8", the pipe will fracture leaving a ragged end. Cutting time for the steel and basalt is about 25 minutes for 10" I.D. pipe.



As shown in above figure, this ragged end should be ground smooth.



Measure and tack weld the new flange in place, matching the bolt hole pattern with the other flange. Permanently weld the flange in place using a "stitch" weld procedure to produce a continuous weld bead. Generally, a 3/8" fillet weld is recommended.

Welding is not usually recommended on the steel casing of basalt lined pipe. However, when welding a flange on the end of a field cut pipe, the heat will dissipate quickly enough that little damage to the mortar or basalt liner will occur. If required, weld about 90° section of pipe and then allow to cool for about 20 minutes.

If it becomes necessary to weld a hanger clip or support to the steel casing of basalt lined pipe in a location other than on the pipe end, a "stitch" welding technique should be used. Do not weld more than 3/4" to 1" at a time and allow to cool after each "stitch".

With a square cut there is no other work required after permanently welding the flange in place. If the cut end is not square and/or recessed more than 1/8" from the flange face to the basalt lining, this should be filled with ceramic trowelable wear compound or epoxy.



The type of cut-off saw and blades recommend for this procedure by Abresist Kalenborn Corporation (www.abresist.com) are:

DeWalt 12" Cut-Off Saw, Catalogue No. DW866, Type I, 5,000 RPM

United Abrasives, Inc. / SAIT, Type 1, Cut-Off Wheel, Grade C24R Concrete, Part No. 23413

Practice the Following

A "walking inspection" of a system is a good means by which well-trained maintenance personnel can often detect potential problems from any unusual sounds made by components.

Make certain to check the owner/operator manuals issued by the supplier for specific instructions on service requirements/maintenance.

It may be a good idea to keep a maintenance "bone yard" where items removed from service can be stored and cannibalized for necessary replacement parts as needed. However, parts taken from used equipment needs to be thoroughly cleaned and inspected before re-use.

References

Piping Handbook, Seventh Edition, McGraw-Hill, Inc., USA.

In-Plant Ash-Handling Reference Manual. Research Project 1835-4 Report prepared for Electric Power Research Institute (EPRI), Palo Alto, California U.S.A.

Ash Handling System Maintenance Guide. EPRI, Palo Alto, CA: 2005. 1011684.

Pneumatic Conveying Design Guide, Second Edition, published by Elsevier Butterworth-Heinemann, Linacre House, Jordan Hill, Oxford OX2 8DP, 200 Wheeler Road, Burlington, MA 01803 (website: www.elsevier.com).

Website

Abresist Kalenborn Corporation: www.abresist.com

Allen-Sherman-Hoff (A-S-H): www.diamondpower.com

Deccan Mechanical & Chemical Industries Pvt. Ltd.: www.demehindia.com

Dynamic Air Inc.: www.dynamicaire.com

Indure: www.desin.com

L B Industrial Systems: www.lbindustrialsystems.com

Macawber Engineering, Inc.: www.macawber.com

Magaldi: www.magaldi.com

MBE EWB Ltd: www.ewb.hu

MELCO India: www.melcoindia.in

National Conveyors Company, Inc.: www.nationalconveyors.com

Nol-Tec Systems: www.nol-tec.com

Schenck Process: www.schenckprocess.com

United Conveyor Corporation (UCC): www.unitedconveyor.com