

# Equilibrium systems

## Studies in Masonry Structure

by

Philippe Block

*B.Sc., M.Sc. in Civil Architectural Engineering*  
*Vrije Universiteit Brussel, 2003*

Submitted to the Department of Architecture  
in Partial Fulfillment of the Requirements for the Degree of

Master of Science in Architecture Studies

at the

Massachusetts Institute of Technology

June 2005

© 2005 Philippe Block. All rights reserved.

The author hereby grants to MIT permission to reproduce  
and to distribute publicly paper and electronic versions  
of this thesis document in whole or in part.

Signature of Author: \_\_\_\_\_

Department of Architecture  
May 19, 2005

Certified by: \_\_\_\_\_

John A. Ochsendorf  
Assistant Professor of Building Technology  
Thesis supervisor

Accepted by: \_\_\_\_\_

Julian Beinart  
Professor of Architecture  
Chairman, Department Committee on Graduate Students

---

William L. Porter  
Emeritus Muriel and Norman Leventhal Professor of Architecture and Planning  
Thesis Reader

---

Herbert H. Einstein  
Professor of Civil & Environmental Engineering  
Thesis Reader

# Equilibrium systems

## Studies in Masonry Structure

by

Philippe Block

Submitted to the Department of Architecture  
on May 19, 2005 in Partial Fulfillment of the Requirements  
for the Degree of Master of Science in Architecture Studies.

### ABSTRACT

This thesis presents new interactive computational analysis tools for masonry structures based on limit state analysis. Thrust lines are used to clearly visualize the forces within the masonry and to predict possible collapse modes. The models are interactive and parametric to explore the relation between the different geometrical parameters and the possible equilibrium conditions. Collapse mechanism analyses are determined by combining kinematics and statics. Complex three-dimensional problems are analyzed using the same methods. This thesis presents a series of analysis tools that are fast and easy to use, but at the same time rigorous and highly accurate.

*Interactive thrust line analysis; Limit state analysis; Masonry structures; Collapse mechanisms; Dynamic geometry; Graphic statics; Kinematic analysis.*

Thesis supervisor: John A. Ochsendorf  
Title: Assistant Professor in Building Technology

To Professor John A. Ochsendorf

## Acknowledgments

First of all, I would like to thank my advisor and friend, Prof. John Ochsendorf, for his generosity, wisdom, enthusiasm and support throughout my research and my life at MIT. Dedicating this work to him does not begin to reflect how much I owe and respect him.

I thank my readers, Prof. Bill Porter and Prof. Herbert Einstein, for their constructive feedback and comments that pushed the thesis that one step further. I wish to thank Maria-Katerina Nikolinakou for the many editing rounds that helped me clarify my thoughts.

I am indebted to Prof. Thierry Ciblac for the many hours he spent working closely together with me during his stay as a visiting professor at MIT and over spring break. Most of the ideas and work originated during our intense collaborations. His thoughtful comments and constructive contributions brought more depth to both the work and the thesis. He and his group also introduced us to the software that made this work possible.

Thanks to John, I had the chance to meet and share my work with several world class specialists in this field of study. Every conversation, discussion or comment brought new perspectives to my thesis. I am especially grateful and honored to have met Prof. Jacques Heyman, Prof. Stephen Murray, Prof. Edward Allen, Prof. Santiago Huerta, Dr. Pierre Smars, Andrew Tallon, and Prof. Louis-Paul Untersteller.

I need to thank the Belgian American Educational Foundation for their very generous financial support, which offered me the chance to come to this stimulating institute and meet so many amazing people.

The research was sponsored by the Schlossman Research Fellowship, the Marvin E. Goody Award, and fellowships sponsored by the MIT-France Program and the Mellon Foundation.

Last but not least, I would like to thank my family for always believing in me, for encouraging me to always pursue my dreams and ambitions, and for always being there for me, certainly in difficult moments. Dank u, mams, paps, meme, Christophe en Sophie om altijd in mij te geloven en me te steunen in alles wat ik doe!

## Contents

<b>Prologue</b>	- 7
<b>1. Introduction</b>	- 8
1.1. <i>Introduction</i>	
1.2. <i>Shortcomings of linear elastic FEA for masonry structures</i>	
1.3. <i>Problem Statement</i>	
<b>2. Methodology: Interactive thrust line analysis</b>	- 11
2.1. <i>Introduction</i>	
2.2. <i>Interactive graphical analysis</i>	
2.3. <i>Geometry controlled loads</i>	
2.4. <i>Animated kinematics</i>	
2.5. <i>Slicing technique (3-d analysis)</i>	
2.6. <i>Summary</i>	
<b>3. Static analysis</b>	- 18
3.1. <i>Introduction</i>	
3.2. <i>Natural stone arch</i>	
3.3. <i>Flying buttress</i>	
3.4. <i>Romanesque church</i>	
3.5. <i>Fan vault</i>	
3.6. <i>Quadripartite and groin vault</i>	
3.7. <i>Summary</i>	
<b>4. Combined static and kinematic analysis</b>	- 25
4.1. <i>Introduction</i>	
4.2. <i>Arch on spreading supports</i>	
4.3. <i>Arch mechanisms</i>	
4.4. <i>Arch on leaning buttresses</i>	
4.5. <i>Summary</i>	
<b>5. Conclusions</b>	- 30
5.1. <i>Summary and discussion of results</i>	
5.2. <i>Future Work</i>	
<b>6. Appendices</b>	- 38
6.1. <i>References</i>	
6.1. <i>Web references</i>	
6.2. <i>“InteractiveThrust”, a web-based tutorial</i>	

## Prologue

When I came to MIT almost two years ago, I did not imagine I would be working on historic structures, but I was introduced to the challenging problems in masonry and found a very interesting field of study. Considering almost half of all construction spending goes into renovation and restoration, and much of the world's architectural heritage is built in masonry, I believe this field of research deserves greater attention than it receives today.

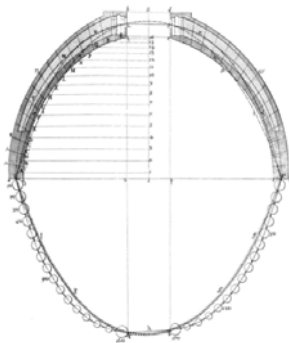

**Fig.0.1.** Poleni's analysis of the Dome of St.-Peter's in Rome [1748].

The essence of my thesis can be captured by the brilliant anagram written by Robert Hooke (1635-1703) in 1675: "*ut pendet continuum flexile, sic stabit contiguum rigidum inversum*".<sup>1</sup> The first time this idea was rigorously used to analyze a real structure was by Poleni [1748] for the Dome of Saint-Peter's in Rome (Fig. 0.1). He showed that the dome was safe by employing the hanging chain principle. For this, he divided the dome in slices and hung 32 unequal weights proportional to the weight of the corresponding sections of that 'arch' wedge, and then showed that the hanging chain fits within the section of the arch. This idea and drawing by Poleni got me interested in masonry structures.

This thesis consists of three main parts. The first part is a condensed summary of the research work that serves as the basis for a journal paper to be submitted this year. This part is kept short and concise to give a brief overview. The second part, included in the conclusions, consists of thoughts about future work and relevant research questions that arose out of this thesis. I tried not only to ask questions but also to project ideas that need further exploration. The third part consists of a web-based tutorial providing interactive applets with user guidelines and comments, teaching and explaining the basics of the structural behavior of masonry structures. I chose to present an important part of the thesis using this media so that the user benefits from the interactive and parametric setup of the applets and models. A paper-only-thesis would not make much sense since the main idea of the thesis is to bring structural ideas in a more understandable and more visual, manner by the use of computation. Also, such a tutorial would be more valuable as future reference for others.

<sup>1</sup> *As hangs the flexible line, so but inverted will stand the rigid arch*, translation by Heyman [1995].

## 1. Introduction

### 1.1. Introduction

Much of the world's architectural heritage consists of historic buildings in masonry. In addition to their historical and cultural values, such monuments often have important economical values. As an example, the partial collapse of the vaults in the Basilica of St. Francis of Assisi during the 1997 earthquake in Italy, caused the destruction of irreplaceable and priceless frescos by Giotto and Cimabue of the early 14<sup>th</sup> century [Crocì 1998]. As a result, the town and region lost income from tourism while the church was closed for restoration. Even more tragically, four people lost their lives when the masonry vaulting collapsed. Though many historic masonry structures have survived for centuries, there is an acute need for new tools to analyze the stability and the safety of such structures.

In most cases, masonry structures fail due to instability rather than a lack of material strength [Heyman 1995]. Stresses in masonry structures are typically only a fraction of the crushing capacity of the stone. Therefore, rigid block models with the same proportions as the structures are good models to understand their stability. Unlike problems in elasticity, stability problems can be scaled. Therefore, an equilibrium approach is most appropriate to understand the structural behavior of masonry constructions. The master builders of the Middle Ages were able to use geometrical rules, developed through centuries of trial and error, to build structural elements by scaling up the same proportions for new larger elements [Huerta 2004]. In those days, there was no knowledge of material properties or allowable stresses. Yet, many of these architectural marvels are still standing in a state of equilibrium. A stability or equilibrium approach will be most valuable, and limit analysis provides a theoretical framework. To apply limit analysis to masonry, it is necessary to make three main assumptions: masonry has no tensile strength; it can resist infinite compression; and no sliding will occur within the masonry. For additional background on limit state analysis for masonry structures, we refer the reader to Heyman [1995], Huerta [2001] and O'Dwyer [1999].

The graphical method for limit analysis using the well known concept of a line of thrust<sup>2</sup> is used. This is a theoretical line, which represents the path of the resultants of the compressive forces through the stone structure. For a pure compression structure to be in equilibrium with the applied loads there must be a line of thrust that lies entirely within the section. The line of thrust can also give information about

---

<sup>2</sup> The concept was first rigorously formulated by Moseley [1833]. An excellent mathematical treatment was offered by Milankovitch [1907]. It has been defined more precisely as the "locus of pressure points" by Ochsendorf [2002].



Equilibrium systems.  
Studies in masonry structure.

possible collapse mechanisms, in that everywhere the thrust line touches the boundaries of the structure a hinge will be created.

### 1.2. Shortcomings of FEA methods for masonry structures?

A finite element analysis (FEA) can show the stress level predicted in the material based on linear elastic analysis. Consider two arches (Fig. 1.1), one with a thickness to centerline radius ratio of 0.08 (a) and one of 0.16 (b), acting under their own weight and supported by rigid abutments. In trying to understand and explain the results, the typical crack pattern at the crown of the arch may be predicted by the thin zone of compression along the extrados and the tension zone on the intrados. The FEA outputs of the two arches are very similar and it is difficult for the FE analyst to note any significant difference between the two arches of Fig. 1.1. The results of a simple limit state analysis on the other hand immediately reveal the major difference between the two arches. The arch with a thickness to radius ( $t/R$ ) ratio of 0.08 is too thin to contain a thrust line and therefore, would not stand under its own weight unless the arch material had some appreciable value of tensile capacity. Therefore, the finite element analysis gives an unsafe and deceptive result.

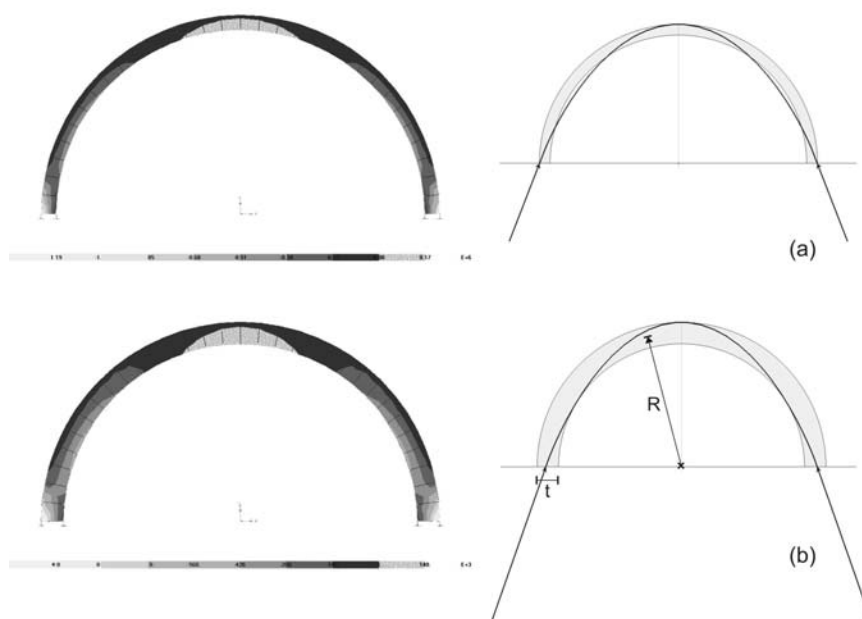

**Fig.1.1.** FEA vs. LSA for arch with  $t/R$  ratio of 0.08 (a) and 0.16 (b).

The power of the simple line of thrust is clearly shown in the previous example. While the FEA shows one possible stress state in the material, it does not say anything about the stability or collapse of the arch. This is a very simple and well-known problem, but it immediately shows how hard it is to draw significant conclusions using FEA, even for

Equilibrium systems.  
Studies in masonry structure.

simple two-dimensional problems. The possible equilibrium configuration illustrated by the thrust-line analysis helps to understand the results of a FEA. As a conclusion, the thrust line gives more information about collapse than a FEA and provides an immediate check for the stability of unreinforced masonry structures.

One must also consider the relative speed of both analysis methods. Collapse mechanisms and crack genesis with large displacements are not easy to simulate using finite element analysis. Setting up a model with correct parameters, interpreting the results and checking if the initial assumptions were valid, requires the very meticulous and conscientious work of a specialist in non-linear finite element methods. To achieve more realistic and accurate results with finite elements, a great level of detail for the model is necessary, but most of the parameters are highly uncertain. For example, the material properties of the ancient stone and mortar are very inhomogeneous and do not have constant and predictable mechanical properties. The thrust line approach on the contrary makes very simple, but accurate approximations. Thrust line analysis can be used to model and understand complex systems and collapse mechanisms. Afterwards the initial assumptions can be verified to ensure that the structure is not at risk of sliding or compression failure. However, none of the existing methods using thrust line analysis can be considered as a satisfactory method to be used by engineers as a general analysis tool. At present day, it is not flexible enough to understand complex structures but for specific problems such as masonry arch bridges or simple arches it is very useful. In the 19<sup>th</sup> and early 20<sup>th</sup> century the graphical method was the only method used to design all masonry arch bridges<sup>3</sup> all over Europe. [Dupuit 1870] These bridges are still standing without any significant problems. However, many historic buildings are not in danger of collapse due to live loading, and are threatened more by the gradual destabilizing effect of large displacements over time.

### 1.3. *Problem statement*

There is an acute need for programs to better understand the structural behavior of historic buildings. For historic structures, but also for new designs, basic static equilibrium is the most important principle, but it is often neglected. In this field of study, there are many challenging issues that are waiting to be addressed, for example a solid and respectable analysis program based on Limit State Analysis, to replace the Finite Element Analysis programs that are largely inappropriate for historic masonry structures.

---

<sup>3</sup> Excellent programs such as Archie-M [A] and Ring [B] have been developed for the limit state analysis of masonry arch bridges under live loading.

## 2. Methodology: Interactive thrust line analysis

### 2.1. Introduction

This thesis has developed new analysis tools for architects and engineers using thrust lines, specifically for vaulted masonry buildings, which are also interactive learning tools for historians and architects. Thrust lines are used to illustrate possible collapse modes and to allow users to clearly visualize the forces within the masonry. This thesis provides vastly improved computation tools for thrust line analysis, offering interactivity so that the user can explore various equilibrium states easily. For most historic structures there are infinite possible load paths and the programs developed can be used to illustrate the range of these potential solutions. The new methods clarify this statically indeterminate character of masonry structures through visual tutorials. A number of applets are created to address these issues. Their parametric setup allows the user to understand the role of geometry in the stability of masonry structures. Finally, the thesis explains collapse mechanisms by combining kinematics and statics, and analyzes more complex three-dimensional problems with the same methods. This approach brings a rigorous and accurate analysis tool that due to its interactive and visual character can also be used as a learning tool. We will explain this new approach by introducing its different components:

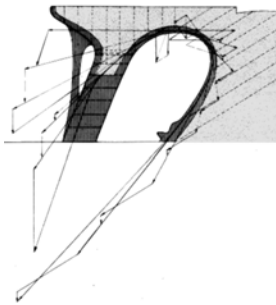

**Fig.2.1.** Gaudí's graphical design for the columns and retaining wall of the Park Güell [Rubió 1913].

- interactive graphic analysis,
- geometry controlled loads,
- animated kinematics, and
- slicing technique (for 3-d).

### 2.2. Interactive graphic analysis

Graphic statics is a powerful method for equilibrium analysis formalized in the 19<sup>th</sup> century by Karl Culmann [1866] for use in structural engineering.<sup>4</sup> Master builders, such as Robert Maillart, Gustave Eiffel, and Antoni Gaudí (Fig. 2.1), used the method to create some of their greatest works. As Boothby [2001] pointed out, the graphical method becomes too tedious and unwieldy for the analysis of complex three-dimensional structures, both because of the complexity of the drawings and the specific knowledge of the techniques needed to construct the analysis of such structures. It involves tracing over different possible solutions and only coming to satisfactory results through extensive trial and error. Today's analysts do not have the patience or the specific skills to consider this as an acceptable technique. Recently, colleagues at MIT created interactive graphic statics methods which suggested the possibility

<sup>4</sup> Graphic statics or rather the notion of vectors existed long before that [Pirard 1967].

of using computerized graphical methods for the interactive analysis of masonry structures.<sup>5</sup> This precedent inspired the current research.

For the work in this thesis, all graphic constructions are prepared in advance, so that the user does not have to worry about the specifics of how to make such an analysis, but can take advantage of their intuitive and visual representation. Through computation, it is possible to show all the possible funicular solutions for a certain set of loads without having to redraw the entire construction (Fig. 2.2). This is only possible because all constructions are interactively controllable and are being updated in real time. We use simple two-dimensional drawing packages that allow the construction of interactive and parametric drawings to make all models and applets.<sup>6</sup>

**Fig.2.2.** Graphic statics is a method that allows the construction of funicular shapes (only tension or compression) for a certain set of loads (a), using Bow's Notation and a force polygon (b) that gives the magnitude of the forces of the segments in the funicular polygon (After Zalewski and Allen, 1998).

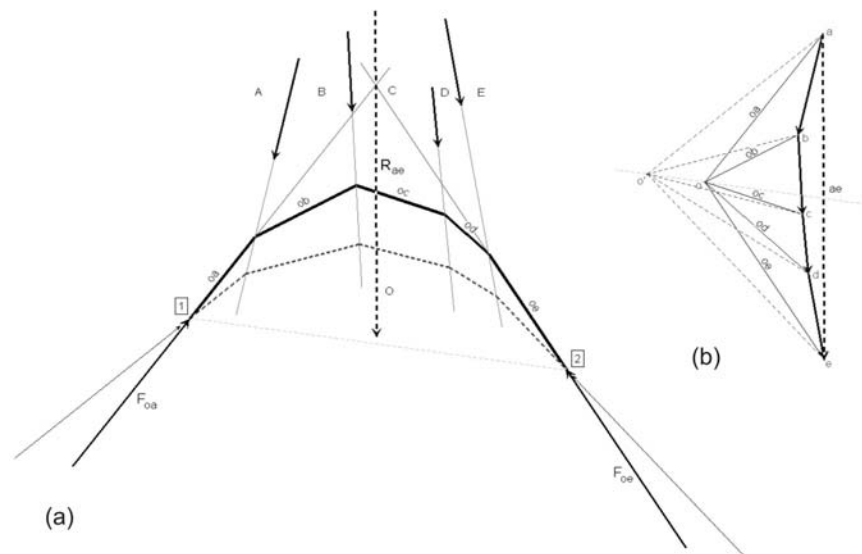

### 2.3. Geometry controls the loads

The geometry of the structure being analyzed controls the loads that are used to do the graphical analysis behind the interface (Fig. 2.3). Changes in geometry will alter the volume, and therefore the weight, of the blocks. This influences the force polygon and hence the state of internal forces as represented by the thrust line. The possible thrust lines of a structure can be found using these graphical methods. To avoid having to draw a graphic statics construction for every structure being analyzed, the models must be generic, representative of a family of similar structures, and parametric so that every characteristic of them, geometric

<sup>5</sup> The applets titled “Active Statics” were developed by Simon Greenwold in collaboration with Edward Allen and Waclaw Zalewski. Available for free download at [D].

<sup>6</sup> The software used is *Cabri Geometry II*. A demonstration version and further details are available at [E].

Equilibrium systems.  
Studies in masonry structure.

and other, can be changed. When a family of related structural elements is included in one model, this provides a quick tool to compare the relative influence of geometry on the range of possible stable conditions. Because this is possible in real time, the methods developed here have important qualities as learning tools. Immediate structural feedback is given as the user changes the geometry on the screen. In the applets, the geometry is changeable by actively dragging control points on the screen or by inputting actual values.

The geometry of the structure limits the range of infinite possible thrust lines, since only the ones within the section are possible equilibrium states. The minimum and maximum thrust states are these extremities representing the least and most horizontal thrust the structure transfers to its abutments. A deeper arch has less horizontal thrust compared to a shallower one. The force polygon visualizes this clearly. For example in Fig. 2.3, the horizontal thrust, represented by the distance of the pole  $o$  to the load line, of the dotted thrust line is smaller than for the continuous thrust line.

**Fig.2.3.** The actions of the different blocks are treated as lumped masses applied at their center of gravity (a). The magnitudes of the forces are proportional to their weight and transferred to the force polygon (b). Two possible thrust lines (funicular solutions) are shown in (a). (c) shows the equilibrium of a single “voussoir”.

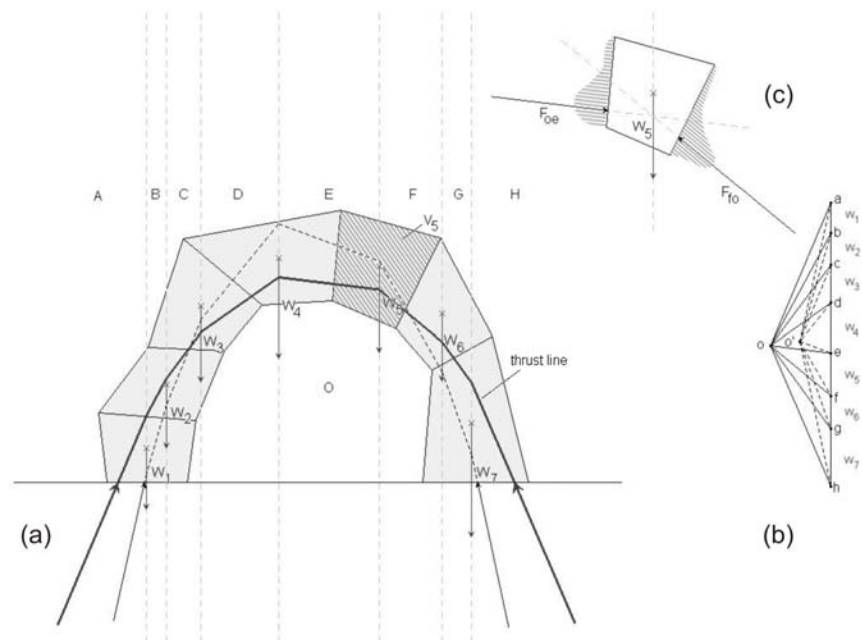

As suggested in Fig. 2.3c, the line of thrust represents the resultants of distributed loads on section through the section. Fig. 2.4 explains how the location of these resultants, hence the thrust line, can be related to the geometrical safety of the structure.

Equilibrium systems.  
Studies in masonry structure.

**Fig.2.4.** Visualization of what a constant resultant means on different parts of the section (a-d). The entire section is not effective in (d). Culmann's kern for a rectangular section is shown in (e).

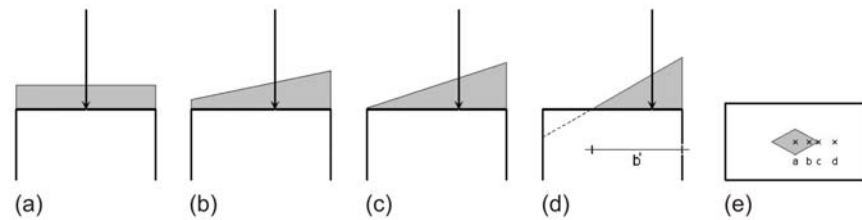

As long as the force resultant on a section stays within its middle third, the entire section is in compression (Fig. 2.4a-c).<sup>7</sup> Going outside the middle third would cause tension in a part of the section and assuming no tensile capacity in masonry, this means that the entire section would not be effective or actively contributing (Fig. 2.4d). This notion is important in order to relate the position of the thrust line to cracks and the formation of hinges.

#### 2.4. Animated kinematics

Large displacements of 30 cm or more are common in historic masonry structures as a result of differential settlements in foundations, defects in construction, and consolidation of materials. The current method does not seek to determine the cause of the displacements but rather aims to understand their importance for the stability of the structure. To do so, a kinematic analysis approach is necessary in addition to the static analysis. By combining kinematic and static analysis it is possible to understand the range of possible motions and to assess the relative stability of the masonry structure.

**Fig.2.5.** Possible limit of deformation when this arch becomes unstable (a) and a snapshot of animation during collapse (b).

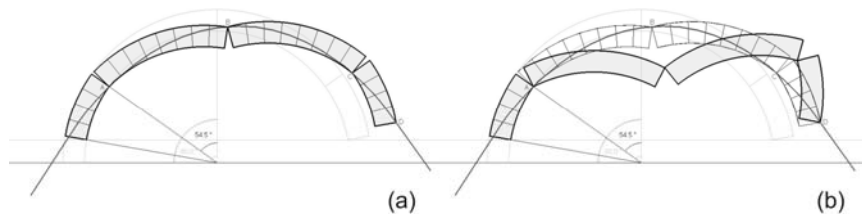

The different steps in this process are summarized as follows:

1. The line of thrust in its extreme positions (minimum or maximum thrust) provides the possible hinge locations. Anywhere the line touches the boundaries of the structure, a hinge may be created and this suggests a possible kinematic mechanism. There is a relationship between the displacements and the state of thrust of a structural

<sup>7</sup> For a horizontal section (Fig.2.4e), the same notion or relation is given, using *Culmann's kern*. As long as the resultant stays within the grey area (= kern) the entire section acts in compression.

element. For spreading supports it will be in a state of minimum thrust and for closing supports in a state of maximum thrust.

2. This information is used to create a dynamic mode with rigid body movements. The thrust line is constantly updated throughout the movement.
3. Many masonry structures will deform as a stable three-hinge mechanism. When the line of thrust touches the structure's boundary at a new point, a fourth hinge is created and the structure becomes an unstable collapse mechanism, as in Fig. 2.5a.<sup>8</sup>
4. Animations show what happens after this point (Fig. 2.5b). They determine one possible collapse state by looking at the information given by the thrust line.

**Fig.2.6.** Four hinges define a three-bar-mechanism. At collapse, bar 1-2 and bar 3-4 rotate clockwise.

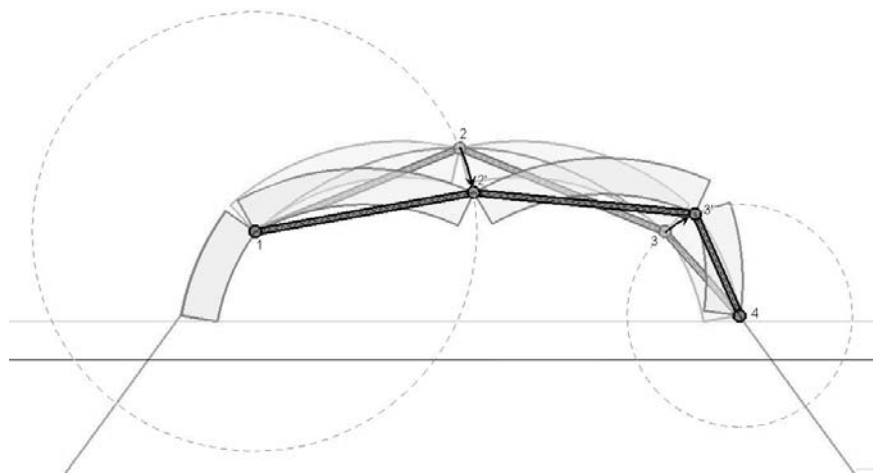

As shown in Fig. 2.6, the movement and behavior of a cracked arch during support movement and collapse can be abstracted and explained using a rigid bar model. The analysis of the structure as an assembly of rigid blocks allows for this abstraction.

### 2.5. Slicing technique (only for 3-d analyses)

To apply limit state analysis for three-dimensional vaulted structures their structural behavior is often simplified using the slicing technique. Basically, the dome or vault is cut into slices or strips.<sup>9</sup> Structurally, this means that their structural action, through a series of possible load paths, is abstracted to a combination of

<sup>8</sup> Hinges must occur on opposite sides of the arch in order to allow the mechanism to form.

<sup>9</sup> This method was used by Poleni to analyze the Dome of St-Peter's (Fig. 0.1).

Equilibrium systems.  
Studies in masonry structure.

simple arches (Fig. 2.7b). In principle, the way to make the cuts can be chosen by the analyst but O'Dwyer [1999] and Huerta [2004] show that the decision will influence the accuracy of the internal results.<sup>10</sup>

**Fig.2.7.** Typical cracking pathology for a Gothic quadripartite vault (a) and an assumption of a possible load transferring system: divided in parallel arches (b). [Heyman 1995]

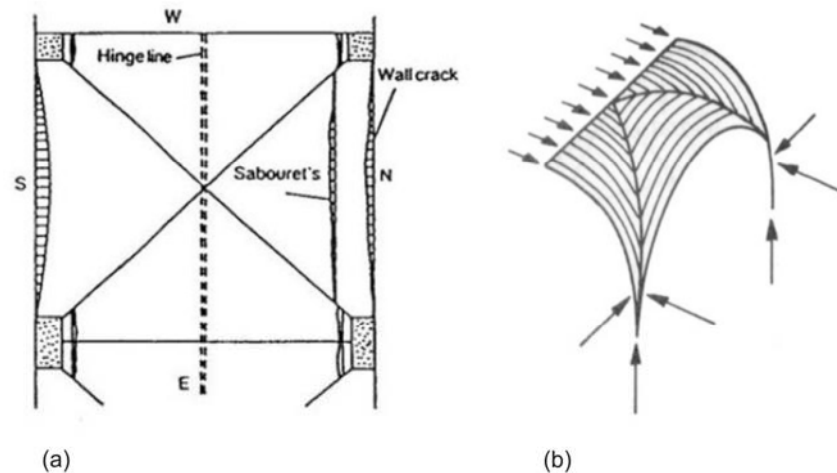

To assume load paths that make the most sense, it often helps to look at the actual structure or structural system. Looking at typical pathologies of certain structures can help to understand how the structure might be acting. As an example, Fig. 2.7a shows a plan view of a Gothic vault with typical deformations. The French engineer Sabouret [1928] gave his name to cracks separating the vault from a separate arch spanning between the buttresses [Heyman 1995]. Other cracks, e.g. wall cracks, are parallel to these. Through the appearance of cracking as a result of displacements, the structure is dividing itself into arches that illustrate the flow of forces in the vault (Fig. 2.7b). This suggests that using the slicing technique, establishing a loading system parallel to the cracks, is a good approximation of how the structure actually stands. No load paths can travel perpendicular to the open cracks since there is no contact point to transfer the compressive forces.

The slicing approach is a very conservative and safe method since beneficial three-dimensional effects are not being taken into account, but the cost and time to do complex real three-dimensional analyses has to be weighed against the additional information they would offer. Therefore, despite being conservative, the present method provides a quick approach that yields meaningful results and a range of possible thrust values for these structures.

<sup>10</sup> Of course, global equilibrium has to be maintained at all time and therefore the global results will not vary.



Equilibrium systems.  
Studies in masonry structure.

## 2.6. Summary

This chapter presented a new approach, based on limit state analysis, to assess the safety and stability of masonry structures. It uses the calculation power and interactive potential of computers to revive earlier analysis methods. The methodology is summarized by its components:

- interactive graphic analysis,
- geometry controlled loads, and
- animated kinematics.

To apply this method to three-dimensional structures, the structure in question must be sliced in parts allowing for the same two-dimensional thrust line analyses to be used.

The two following chapters will present several examples of the applets, increasing in complexity, each showing a different aspect and quality of the new approach. For most of the applets, different methods to represent data and results are explored. The first group of models shows lower bound<sup>11</sup> static analyses. Chapter 3 presents 2-d structural elements, structural systems and finally examples of analyses of 3-d vaulted structures using the same methods. The second group of models (chapter 4) combines statics and kinematics to visualize and examine the stability of 2-d masonry structures undergoing large displacements and deformations.

---

<sup>11</sup> The safe theorem of the plasticity theory states that if one possible, lower bound, solution can be found that satisfies equilibrium, the structure will be safe [Heyman 1995].

### 3. Static analysis

#### 3.1. Introduction

This chapter presents examples of static analysis tools for a wide range of structural elements. The purpose of these is to understand the capacity, defined by its minimum and maximum thrust, of a specific element or to investigate the importance of geometrical properties to their structural performance and compare a family of similar elements. First, two-dimensional problems are chosen to demonstrate different results obtainable with this new approach and at the end of this chapter examples are shown of the use of slicing that can be used to analyze complex three-dimensional structures with the same intuitive methods.

#### 3.2. Natural stone arch

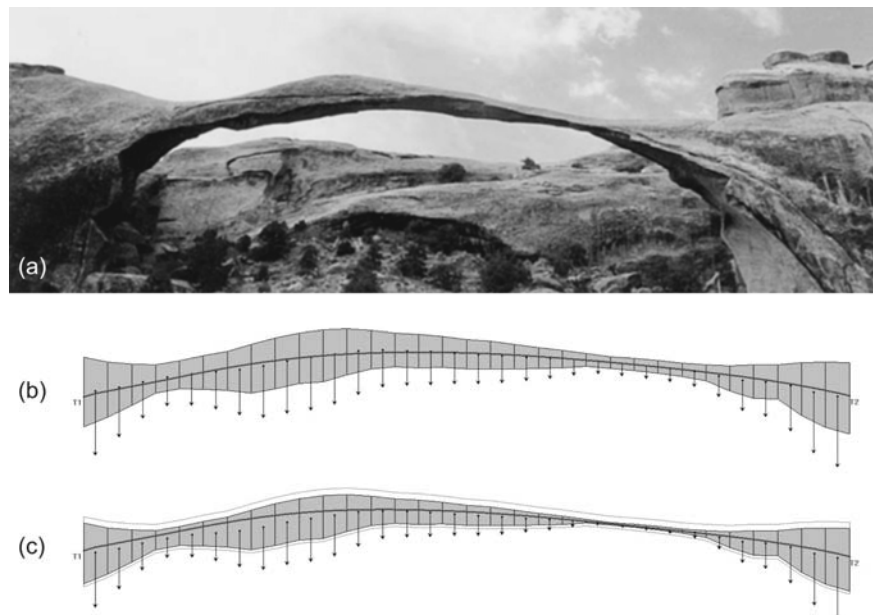

**Fig.3.1.** 'Landscape Arch' in Devil's Garden, Arches National Park in Utah, USA (a) and a model showing a possible thrust line of this natural arch, currently (b) and after (c) erosion simulation.

In this applet, the user starts from the geometry of a natural arch (Fig. 3.1b). By dragging the nodes of every segment the geometry can be changed and the thrust line is updated automatically. This allows the user to play with its shape to understand when a virtual arch would not be able to stand. Once an initial geometry is chosen erosion can be simulated (Fig. 3.1c). The stone arch will stand as long as at least one thrust line can be found that lies within the section. If the thrust line does not travel through the section, this would mean that the compressive forces are traveling through the air. This is of course not possible, if the stone arch

Equilibrium systems.  
Studies in masonry structure.

cannot resist tension. Stone has no or very little tensile capacity, so, the structure would collapse if it cannot contain a thrust line in compression. This first example shows the power of the line of thrust in that it explains the structural stability of these natural marvels in a very easy way: if a line that fits within the arch's profile for the given loading can no longer be found, then the arch will collapse.

This example illustrates how a structural form can evolve over the years. This is a perfect example of a natural optimization process, because parts of the stone structure that are not over a certain threshold of compression are eroded. Regions of higher compression have hence a higher resistance to erosion, which in this climate does not come from rain as much as from dry sand particles being carried by the wind.<sup>12</sup> So, the behavior and evolution of these structures is more refined and complex than it appears at first sight. Nevertheless, thrust line analysis provides a very good introduction to the problem of the arch stability.

### 3.3. Flying Buttress

This new method is very powerful for comparing a large number of geometrically related structural elements (Fig. 3.2). A recent study [Nikolinakou et al 2005] of early French Gothic flying buttresses used this approach to quickly analyze twenty flying buttresses. They were able to make interesting conclusions on the evolution of their shape and the influence of different geometrical parameters on their performance. Other aspects such as sliding checks or the influence of the pinnacles on the stability of the flyers were implemented in the same visual manner.

**Fig.3.2.** This flyer of a church in Agnicourt, France (a) is clearly in a state of minimum thrust. (b) and (c) show two possible flyer with the same span  $B$  but different geometrie, both showing a minimum state of thrust.

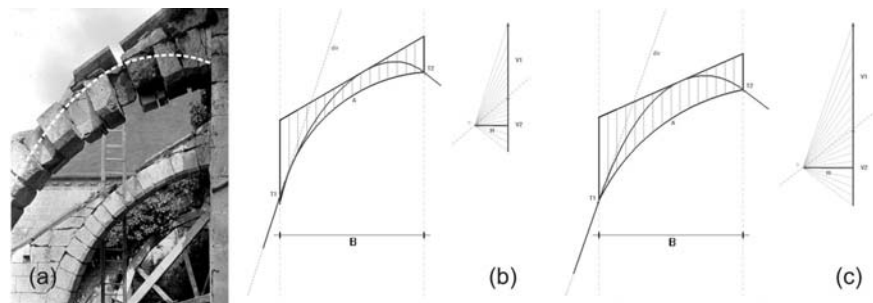

For every geometry, there is an infinite amount of valid thrust lines that fit within the section, all lying between a maximum and minimum value. Both flyers in Fig. 3.2b-c are in a state of minimum thrust. Their relative weight and thrust value can immediately be compared visually by the size of their respective force polygons. As an

<sup>12</sup> Many other effects such as cracking due to temperature differences can cause erosion.

Equilibrium systems.  
Studies in masonry structure.

example, we find that the minimum thrust of flyer (b) in Fig. 3.2 is 26% of its total weight and 27% for (c). The total weight of the thinner flyer (b) is 70% of that of flyer (c). The minimum thrust, or passive state, of a structural element can be understood as the minimum amount of force with which this element pushes against its neighbors or abutments (Fig. 3.2a). The maximum thrust, or active state, of that element is then the maximum amount of horizontal force it can transfer or provide. This value can become very big and therefore the maximum thrust will be limited by the material's crushing strength or, often sooner, by the stability of the neighboring elements, such as buttresses or walls.

### 3.4. Romanesque church

This project looks at an entire system, bringing different structural elements together and showing how they interact, which started from collaboration with art historians at Columbia University.<sup>13</sup> We were asked to develop a tool to analyze one hundred small Romanesque churches in France (Fig. 3.3).

**Fig.3.3.** Interface of the applet used to analyze Romanesque churches, using a sectional approach. Here applied to a small 12<sup>th</sup> century church in Franchesse in the Bourbonnais region of France.

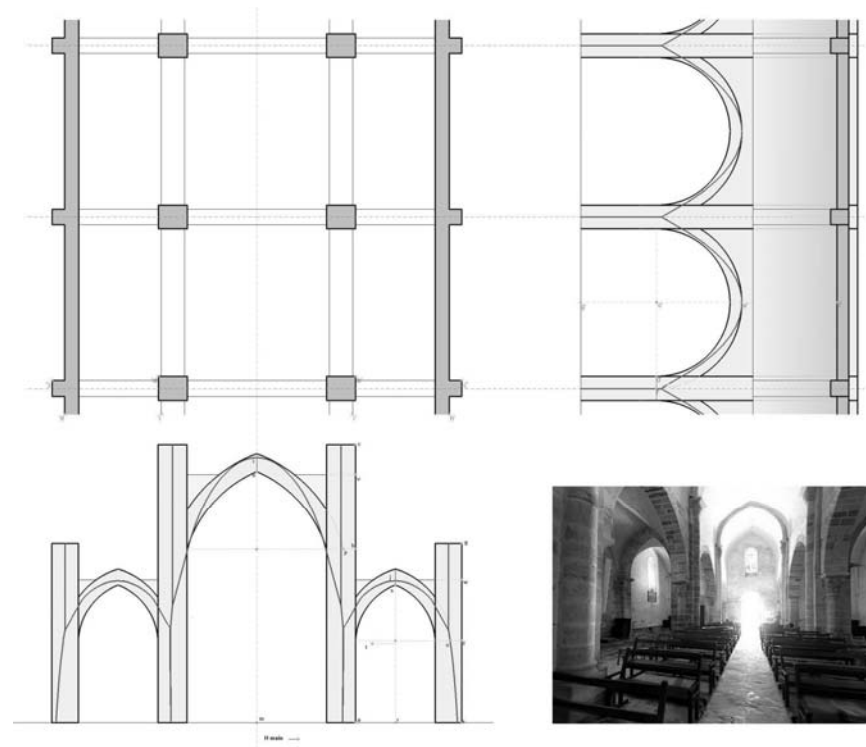

The generic and parametric model is able to generate all possible church sections. Parameters such as the proportions of buttresses and arches, full or half semicircular arches versus pointed arches, the thickness

<sup>13</sup> Background information about this program, directed by Prof. Stephen Murray, can be found at [F].

of vaults, or the level of fill above the vaults. A sectional analysis is very good for a first and quick analysis, because “Romanesque buildings are nearly the most two-dimensional buildings in existence.”<sup>14</sup> By adding another sectional analysis for the other direction, the tool provides a complete analysis method for the static equilibrium of these church geometries.

Most of these churches have severely deformed arches and leaning buttresses and they often are a collage of elements added over a long period of time. Most deformations and probable reasons for these retrofits can be explained and shown quickly using the analysis methods developed in this thesis. The very visual and intuitive interface with thrust lines serves as a way to communicate structural ideas, visualize the stability of these structures, and explain these pathologies to an interdisciplinary audience in a clear and understandable way.

It is not trivial to understand the indeterminate character of these masonry systems, meaning that an infinite number of possible states are possible. An interesting way to represent this is proposed in Fig. 3.4b<sup>15</sup>, plotting the area containing all admissible combinations of thrust values of the structural system of Fig. 3.4a. The thrust provided by the side arch ( $H_2$ ) is given as a function of the thrust of the main arch ( $H_1$ ). The boundaries of the solution area are the minimum and maximum thrust of both arches and the maximum capacity of the main and side buttresses ( $H_A$ ,  $H_B$ ). In order to ensure a safe solution in which the entire section of the buttress is acting in compression, it is of interest to include the limits of the middle-third for each buttress.

**Fig.3.4.** Half of a generic section of a Romanesque church (a) and a representation of all possible thrust values of this system (b).

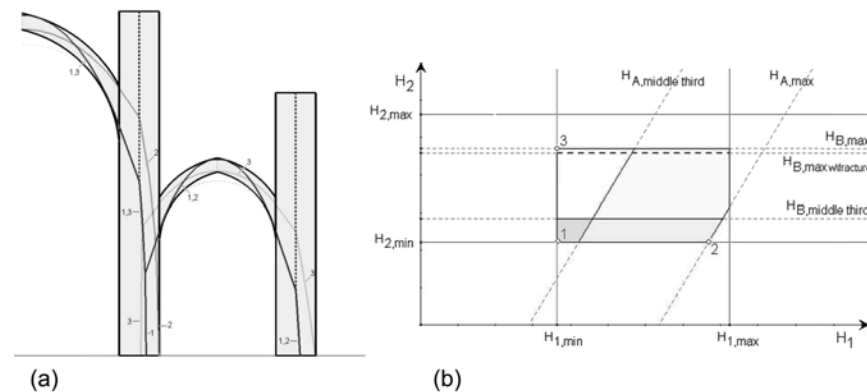

Three possible limit cases (1-3) are shown. Notice that only case 1 lies within the completely safe area (darker area on graph), where the thrust line in both buttresses stays within its middle third. The origin for this geometrical safety was explained in Fig. 2.4.

<sup>14</sup> Quote by Stephen Murray (June 2004).

<sup>15</sup> Original idea of this representation by Pierre Smars [2000].

### 3.5. Gothic fan vault

Late Gothic fan vaults were built in England in the 15<sup>th</sup> and early 16<sup>th</sup> century. Though many of these architectural marvels are standing, the structural answer for this is not trivial at all due to the negative Gaussian curvature of the vaults. The vaults of the chosen case study, King's College Chapel (Fig. 3.5c), are even more astonishing because the ratio of the thickness of its vault<sup>16</sup> to the span is smaller than the thickness to span ratio of an eggshell. This is using a material that only works in compression, so somewhere in the thickness of this vault must lie a force network that transmits its self weight to the supports only through compression. A modern structural engineer would hesitate to sign for the safety of such a structure, yet it has stood for 500 years.

This example shows that with very simple sectional analyses a quick idea of the safety of such complex double curved structures can be provided. We adopted the same assumptions as Heyman [1995] taking radial cuts and also providing a lower bound solution. I provided the model and a detailed analysis and conclusions were done by a Cambridge University visiting student, Madhumita Nag, for a research workshop in Historic Structures at MIT. The influences of the level of fill and the boss or the stability of the outside buttresses were aspects checked using this applet.

**Fig.3.5.** Sectional analyses (a,b) of different parts of the vault and an image of the fan vaults inside King's College Chapel, Cambridge University, UK (c).

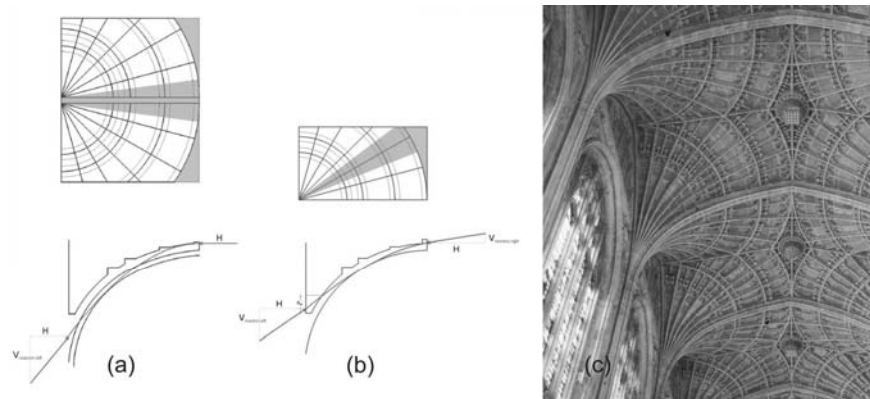

<sup>16</sup> This is the thickness of the vault without the ribs and nerves that are considered to be decorative, though they do contribute to the stability of the vault [Heyman, 19XX].

### 3.6. Gothic quadripartite vault and Romanesque groin vault

The structural behavior of the quadripartite vault has been the focus of debate for centuries. From Viollet-le-Duc to Ungewitter to Heyman, major protagonists in the analysis of masonry structures contributed to the discussion about how quadripartite vaults stand. We use the assumptions made by Heyman that the main ribs bring down the forces to the buttresses and the web is considered to be a collection of parallel arches spanning between the cross ribs (Fig. 2.7b).

The graphical construction in this applet uses the introduced slicing technique and is inspired by the analysis by Wolfe [1921] in his graphic statics manual. Because of its fully parametric setup, this model can represent a wide range of different groin and quadripartite vault geometries. This provides an idea of the relative efficiency of different types of vaults and the influence of changes in geometry to their performance.

**Fig.3.6.** Interface of the applet used to analyze gothic vaults using section (a) and plan (b) to represent the 3-d vault. The local analyses of the strips (c) influence the global analysis of the vault in the main ribs (d).

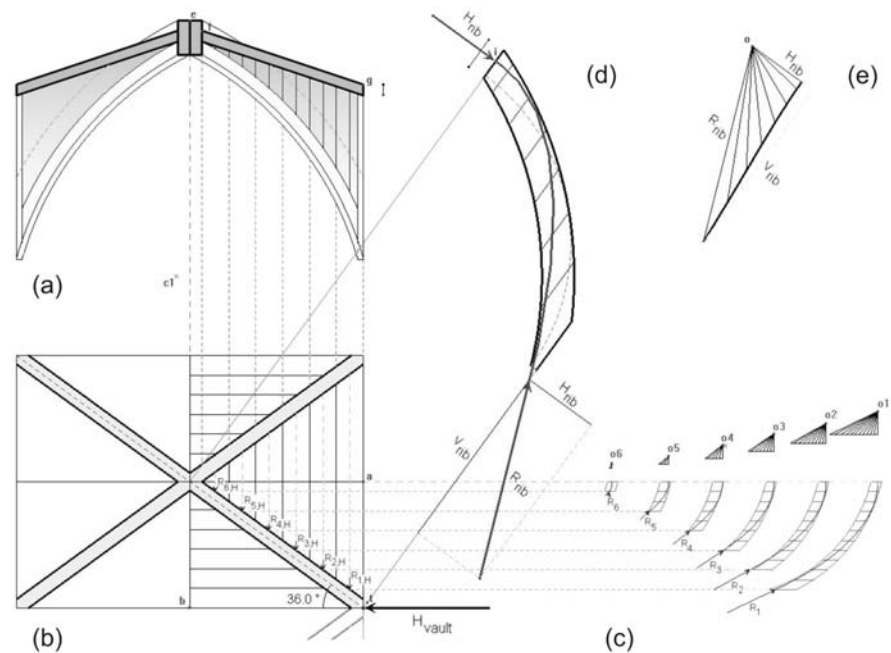

In Fig. 3.6c, the range of possible trust values of the strips can be explored. All their resultants come down on the main rib and influence the position of the trust line in this element (d). Also this element now has a broad range of possible thrust values. Using trigonometry, the total thrust of half of a vault ( $H_{vault}$ ) can be found immediately.

Equilibrium systems.  
Studies in masonry structure.

### 3.7. *Summary*

The examples so far were static analyses, characterized by an infinite number of possible solutions within a range defined by the minimum and maximum thrust of that element or system. This range becomes not so easy to predict for more complex systems where different structural elements interact. A way to visualize the highly indeterminate character of the problem has been proposed (3.4). A range of lower bound solutions for three-dimensional structures can now be produced quickly and easily. This enables the comparison of large families of vaults. This is a major improvement in this field of research, made possible because of the new approaches developed in this thesis.



## 4. Combined static and kinematic analysis

### 4.1. Introduction

To allow displacements, a rigid masonry structural element must develop cracks.<sup>17</sup> This is interesting from a structural point of view, because the formation of cracks means that the structure is not as highly indeterminate, and it becomes easier to determine where the forces are traveling. There is a direct relation between the thrust line and where the hinges occur, as explained in section 2.2.3. From the moment the structure is cracked, the hinges define the location of the thrust line. The limit of displacement which causes collapse, a unique (upper bound) answer, can be explored by applying displacements until it is no longer possible to fit a thrust line in the deformed structure. The concept of collapse due to large displacements was proposed and investigated by Ochsendorf [2002].

Collapse mechanisms and crack genesis with large displacements are not easy to simulate using finite element analysis. The approach demonstrated in this chapter shows complex displacement analyses using simple but powerful methods. These are possible by adding the information of the thrust line to kinematic analyses illustrating the range of possible displacements.

### 4.2. Arch on spreading supports

This applet allows the user to see the effect of spreading supports on the stability of an arch. The displacements are applied by the user dragging a control point at a support. It is a major development to be able to navigate between uncracked and collapse state and to see what is happening in between. This is very visual to demonstrate that (small) cracks in masonry are not problematic and that most masonry arches have large capacity to deform before failing. An interesting feature of this applet is that results are being reported in this same interactive environment. While the user moves the supports, the relation between the change in thrust and the change in span is being traced on a graph in real time, visually linking data generation and the behavior of the model on the same screen (Fig. 4.1f).

When the arch supports begin to move apart, the arch immediately goes to its minimum thrust state [Heyman 1995]. The arch in its minimum thrust state (Fig. 4.1a) provides possible hinge locations. For fixed hinge locations, the mechanism induced by spreading supports is shown. Notice that the purely kinematic or geometrical solution (Fig.

---

<sup>17</sup> Actually, from the moment a masonry arch is being de-centered it can be assumed to be in a cracked state.

Equilibrium systems.  
Studies in masonry structure.

4.1d) is not the point at which the structure fails, because before that a fourth hinge would form and cause collapse (Fig. 4.1c). From this point we have an unstable mechanism that collapses (Fig.4.1e). Theoretically, because of symmetry, a fifth hinge would form at the same time but in reality there are always slight imperfections that make the structure behave asymmetrically. The unique collapse state can be found by determining the conditions which are both statically and kinematically admissible for the maximum applied displacement.

**Fig.4.1.** For an arch with a  $t/R = 15\%$  and a total angle of embrace ( $2\alpha$ ) of  $160^\circ$ : Minimum thrust state (= no deformation, a), an inter-mediate state (b), at collapse (c), and at the geometrical limit (d) [for span increases of 0%, 4%, 11,7% and 18.9%]; Snapshot of the animation showing the collapse mechanism (e); and a plot of span increase in function of thrust increase through-out the movement (f).

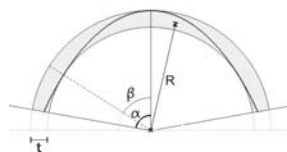
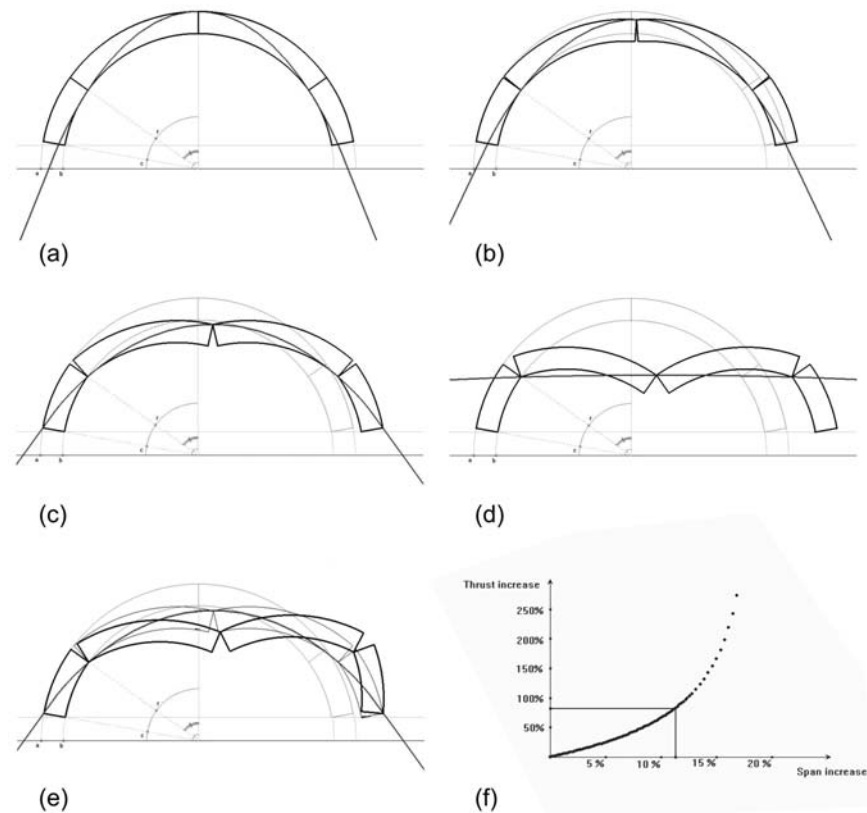

**Fig.4.2.** Conventions used [Ochsendorf 2002].

Earlier studies by Ochsendorf [2002] show that this result is unsafe since the hinge locations are not fixed, but may move during the support displacements. This second order effect is noticeable in the model as well. When moving the supports apart, the thrust line touches the intrados higher than the initial chosen hinge location and might even exit the section. In this applet the user must update the hinge locations manually to account for this effect. Measuring and warning devices are provided to assist in this. We compared our results using these applets to Ochsendorf's results using Matlab for an arch subtending  $120^\circ$  ( $\alpha = 60^\circ$ ,  $t/R = 10.0\%$ ) using his hinge angle at collapse ( $\beta_u = 42.7^\circ$ ) and confirmed the earlier results. The span increase at failure gave exactly the same result

Equilibrium systems.  
Studies in masonry structure.

(8.2%) and the increase in thrust was comparable for both studies (2.17 compared to 2.16 times the minimum thrust).

#### 4.3. Arch mechanisms

The assumed imposed displacements in the previous example are perhaps too theoretical. This applet allows the simulation of more realistic and more general cases of support displacements for an arch, combining differential horizontal and vertical movements of the supports. An example of a study made possible with this applet is a check of how much a support can settle, and hence how much the arch can deform before collapsing to assess the kinematic safety of arches in deformed shapes as in Selby Abbey (Fig. 4.3a).

**Fig.4.3.** Highly deformed arches due to tower construction punching through in Selby Abbey, North East England (a) and 3 limit states of an arch (b). The arch in position *s* is in its undeformed state.

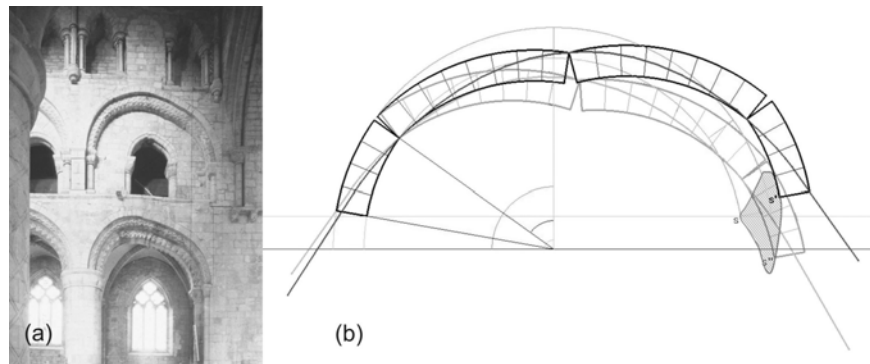

The very visual and clear representation of the locus of all kinematically and statically admissible states of this arch (Fig. 4.3b) is reproduced<sup>18</sup> using this applet by tracing the position of a point on the support; this is shown with the hatched area in Fig. 4.3b. A difference is that instead of having the contours of this solution zone generated by an automated process, the users now trace it themselves exploring the limits. This interactive control adds to the user's understanding of the arch deformability.

#### 4.4. Arch on leaning buttress

Instead of looking at a single structural element (arch on moving supports), this model shows a section of a single nave building, such as a simple arch or barrel vault on buttresses. The arch deforms due to leaning of one of the buttresses. This is a very common pathology noticed in real churches [Huerta and López 1997]. Failure would occur when a new hinge is created on the bottom right (Fig. 4.4c-d). This applet compares maximum lean for a solid, monolithic buttress and for a fractured buttress [Ochsendorf et al 2004] with reduced stabilizing capacity. To incorporate this fracture, a new solving method, using a “ghost” construction, was

<sup>18</sup> Original idea of this representation by Pierre Smars [2000].

Equilibrium systems.  
Studies in masonry structure.

necessary since the problem has several unknowns. The information provided by this first helper construction is necessary to be able to draw the final construction.

**Fig.4.4.** Arch on leaning buttresses with no lean (a), 1.2° (b), 2.5° (c) lean at collapse for the case of a fracture buttress, and 3° for a solid buttress (d).

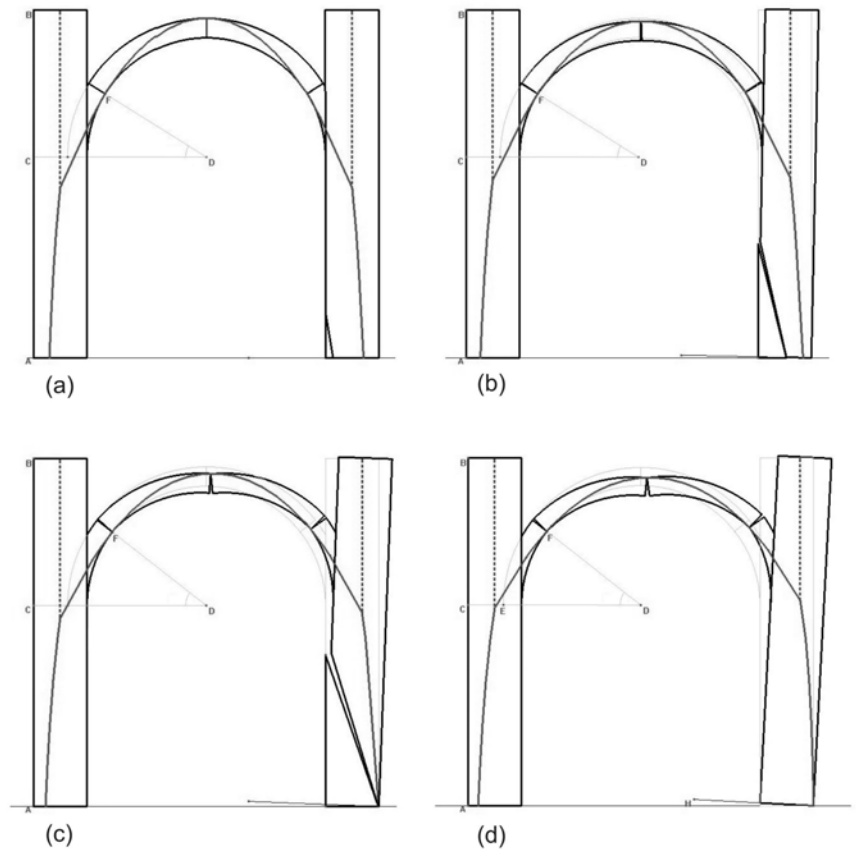

In Fig.4.4 it can be seen that by considering a fractured buttress the maximum lean is reduced from 3.0° to 2.5°.

Equilibrium systems.  
Studies in masonry structure.

#### 4.5. *Summary*

This Chapter was devoted to examples of displacement analysis for two dimensional masonry structures. The determination of hinge locations, stable deformed states and kinematic admissible limits for these structural elements were determined using interactive thrust line analysis. Support movements due to horizontal and vertical displacements, and combinations of them, such as displacements due to rotating abutments, were considered. Animations of possible collapse mechanisms show what happens once there is instability.

Different approaches using tracing were demonstrated to try to visualize results of kinematic effects more appropriately and meaningfully, taking advantage of the interactivity of the applets. The use of a helper construction in the leaning buttress problem, allowed for the computation of the crack propagation in the buttress. This hints that much more sophisticated models are possible, involving non-linear and second order calculations.

## 5. Conclusions

### 5.1. Summary and discussion of results

This thesis proposed and provided a new analysis tools for masonry structures. This approach is:

- interactive and fast;

The geometry of all the models can actively be changed on the screen by the user. Control points allow the user to change different parameters or apply displacements. Structural feedback is given in real-time while the models are being updated.

- rigorous and numerically accurate;

The graphical method is inherently accurate. It only describes static equilibrium, demonstrated by a closed force polygon. The vectors add up and cancel each other out; the system is in equilibrium. No approximations are used to model the kinematic behavior of the masonry structures. The rigid body movements are described using pure geometrical constructions. Most importantly, all models and results have been verified and compared with earlier numerical studies.

- visual and intuitive;

Thrust lines are used to visualize the behavior in a clear manner. They clearly show the indeterminate character of structural elements as well as the existence of maximum and minimum thrust states. Therefore, the interactivity allows the user to understand the range of stable conditions for a masonry structure. In the displacement analyses, the tools provide information about possible collapse mechanisms. Animations show what happens after instability, during collapse. It is very valuable for users to see the structures actually falling down and disappearing on the screen.

- able to model both kinematics and statics; and,

The assumptions necessary to apply limit analysis to masonry structures (cf. Ch. 1) allow displacement analyses to be performed. This is a very large improvement compared to FEA, as pointed out in the discussion in the introduction.

- easy to use by engineers, architects and historians;

Changes are made to the models by grabbing and dragging the control points on the screen. It is very intuitive and adds to the pedagogical value of this approach. This allows the user to have a quick idea of the structural

Equilibrium systems.  
Studies in masonry structure.

behavior. For more in depth analyses actual values can be inputted and changed incrementally to provide maximal accuracy.

It also provides a common language that enables engineers and art historians to communicate, an essential aspect for the study of historic structures.

We believe that for all the above reasons, it is important to share this work as widely as possible to show the value of thrust line analysis, enhanced using computation with added interactivity. Therefore, the developed models and tools are web-based and freely available.

The simple 2-d parametric drawing software allowed the production of many, which are easily exported as web-based applets; however, it is not able to handle very sophisticated, complex problems since the number of processable constructions per model are limited. The interactive aspect is being lost due to increased processing times. Another limitation of these programs is that they limit the problems to the ones that can be described geometrically. In addition, for slightly different problems new models have to be created. For the church applet for example, it is not possible to have in a single model the option to choose between a semicircular or a half arch since these require different geometrical constructions. An open interface which would allow user-defined routines seems necessary to provide more flexibility. It would allow the ability to switch from mode to mode or from construction to construction; to include iterative calculations necessary to simulate second order effects such as the movement of hinges, briefly discussed in section 4.2.; and in general to model more complex systems. On the other hand, developing custom software demands a lot of effort, mainly in designing user interfaces and in allowing active control, and also in verifying their validity and robustness.

Furthermore, the tools are far away from providing understanding of three-dimensional behavior and mechanisms of vaulted structures. The “pseudo 3-d” analyses, using the slicing technique, provide a very conservative possible range of solutions but it does not consider possible beneficial effects due to three-dimensionality or curvature.

More critical issues will be discussed in the following section. It aims to propose new directions for possible future developments to overcome shortcomings of the used methods and the proposed approach in general.

## 5.2. Future Work

This thesis is a first step towards better analysis (and design) tools for masonry structures. There are many interesting and challenging aspects that are waiting to be developed, some of which I hope to address or investigate in a PhD thesis. All the work so far has its value in demonstrating the potential and value of this new approach. By bringing together different ideas, this thesis has provided a convincing approach that shows the power of thrust line analysis for masonry structures.

The *line of thrust* is a simple way to visualize the forces in a structure acting in compression and hence its stability. Yet, this representation is not always as understandable as we would hope it is, since its meaning is not univocal over its path. Along this line for example, the magnitude of the resultant forces change (Fig. 5.1c) or the resultants represent very different loading condition in every section (Fig. 5.1b). Some investigations should be done to try to represent in clear ways the ambiguities of the conceptual line. Some first attempts to address this are shown in Fig. 5.1a-d.

**Fig.5.1.** Different possible representations for the thrust line: rigid bars, proportional to the forces in every ray combined with the equivalent hanging chain model (a); meaning of resultant on different sections throughout the structure (b); flags, indicating the force in each ray (c); and a color code, indicating how far the actual thrust line differs from its most optimal position, the centerline of the structure (d).

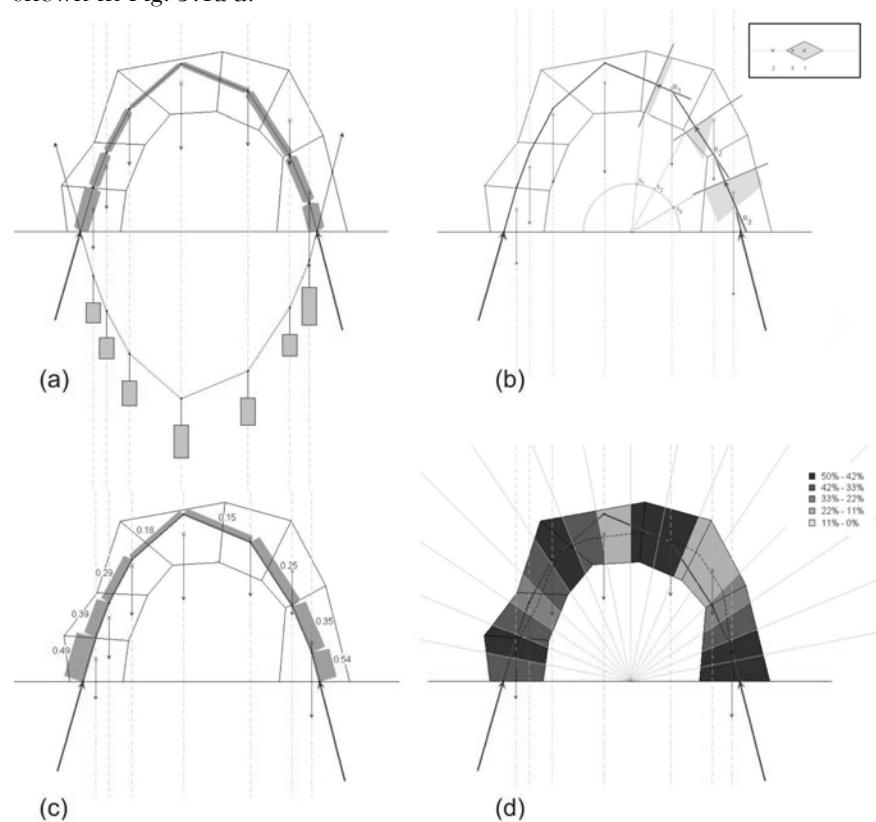

The three main assumptions introduced by [Heyman 1966] for limit state analysis to masonry structures, are reasonable approximations for the mechanical properties of a masonry structural element. However, a



Equilibrium systems.  
Studies in masonry structure.

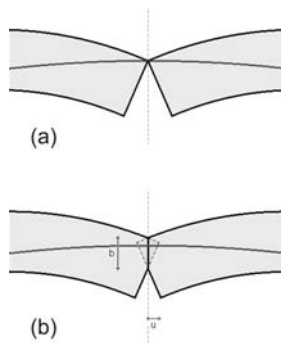

**Fig.5.2.** Local material crushing at a hinge.

pure rigid-plastic analysis does not perfectly approximate its behavior and deformations due to displacements. The assumptions that the masonry blocks have infinite compressive strength and that no sliding occurs are clearly unsafe. Even considering that masonry has no tensile capacity is questioned to be on the safe side by some people for three-dimensional vaulting structures.<sup>19</sup> Only the structure knows the actual force state. The models need to be refined by incorporating material properties to be able to simulate problems of local crushing e.g at the theoretical rotation points in the hinges (Fig. 5.2). A safer stability limit would be found for collapse, since the crushing causes not only the structure but also the thrust line to move in an unsafe way (Fig. 5.2b). So, although the current applets demonstrate the global mechanisms very well, refined models that incorporate these local and second order effects are necessary to assess the safety of historic structures correctly.

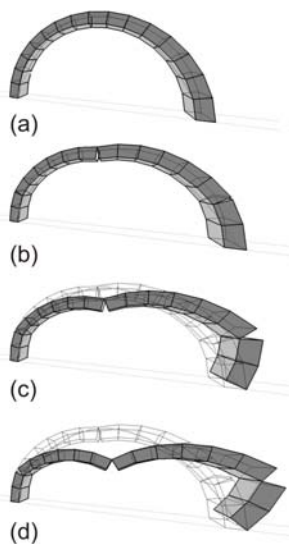

**Fig.5.3.** Possible collapse mechanism of an arch on spreading supports, visualized in 3-d.

In general the biggest remaining challenge is to visualize this interactive and dynamic approach in a three-dimensional realm. The slicing technique enables a possible solution by analyzing the three-dimensional structure as a series of two-dimensional analyses. In this thesis, such an analysis was done for Gothic vaults (Fig. 3.6). The representation was entirely inspired by Wolfe [1921] using a combination of sections and plans to represent the vault system. Instead of using computation only to make this analysis interactive and parametric, it would be beneficial to visualize such an analysis in 3-d, still keeping the same flexibility and simplicity in control. Fig. 5.3 shows an applet illustrating a kinematic analysis and collapse mechanism of an arch on spreading supports in 3-d. While it is not necessary to use a 3-d representation for this problem, this applet does show the power and value of such a representation.

The previous analyses can be called pseudo-3d analyses since beneficial effects due to the three-dimensionality of the structures are not being considered. For domes these beneficial effects are for example the compressive hoop stresses (forces in meridional direction), that are neglected when cutting the structure into independent wedges [Heyman 1995]. Several methods have been developed that try to quantify these 'neglected' (and not well known) forces and incorporate them in the analysis [Lévy 1888]. More sophisticated methods followed and also more complex structures as ogival domes were handled [Oppenheim et al 1989]. These analyses give a better and more realistic idea of the stability of the dome taking into account some 3-d effects. Yet, these methods are not optimal and research is being conducted at MIT to improve them. These are only possible because of the simplicity of the dome problem. A complete analysis approach would handle random 3-d shapes with the

<sup>19</sup> Pierre Smars claimed in our discussion that a three-dimensional vault could be strengthened globally by weakening it at certain places (March, 2005). This is a strange statement that needs more exploration, but that on the other hand reaffirms that it is impossible to know what happens inside the vaults.

Equilibrium systems.  
Studies in masonry structure.

same uniform method. In general, it is necessary to do real 3-d analyses of complex vaulted systems. The following paragraphs will suggest valuable routes to explore further in this area.

Firstly, the Force Network Approach [O'Dwyer 1999] seems very powerful, although it has been only applied and demonstrated for simple structures such as domes. The results are thrust surfaces, called network models, which must fit within the masonry vault. The structure is divided in pieces and their masses are lumped into nodes. These nodes are linked and form the thrust surface or force network. By allowing the nodes to only move vertically on axes through their centroids and assuring equilibrium at all time, thrust surfaces are found that keep the surface within the volume of the structure. Optimization techniques can be used to select network shapes by calculating the geometric factor of safety for a set of given loads or the collapse load factor for an imposed pattern of loads. This seems a very smart way to approach the problem and it is surprising that no further developments were made after Dwyer's thesis. It is not a very flexible method to explore the range of possible solutions, but it does show the potential of thrust surfaces for the analysis of 3-d systems.

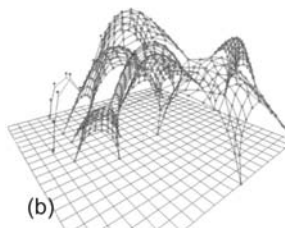

**Fig.5.4.** Gaudí's hanging weights model to find the form of his Colonia Güell (a) and Kilian's particle-spring applet, a virtual hanging chain model (b).

A second approach explores thrust surfaces even further. In recent workshops at MIT three-dimensional equilibrium networks have been explored using particle-spring systems [Kilian and Ochsendorf 2005]. *A bit more explanation on PS system* (Fig. 5.4b)<sup>20</sup>

An unsolved issue is how to relate an actual material (and thickness) to these 3d- network systems. Gaudí's genius was maybe not as much in the fact he used hanging chain models (Fig. 5.4a) but in his capacity to translate these strings into masonry structural elements. Tweaking the stiffness of the spring elements between the lumped masses allows the user to find the infinite range of thrust surfaces in equilibrium with a set of loads.

A third path could research the use of graphic statics for three-dimensional force network systems. For simple 3-d systems, most of them symmetrical and triangulated, graphical techniques have been developed using descriptive geometry to apply graphic statics in three dimensions [Pirard 1967]. It would be exciting to develop an extended graphical method using Bow's Notation for 3-d. A possible key to the solution was implicitly given by Chris Williams [Williams 1986] when describing prestressed reciprocal nets in static equilibrium (Fig. 5.5). "The nets do not have to be flat or have only two set of cables. The equilibrium of a node on one net is ensured by a closed polygon of forces on the other net." He points out the similarity with Bow's notation used for the analysis of plane trusses. I would like to explore this path further in the future. The interesting aspect is that again the geometry would control the loads

<sup>20</sup> The CADenary applet, developed by Axel Kilian, using this particle-spring system can be found at [G].

Equilibrium systems.  
Studies in masonry structure.

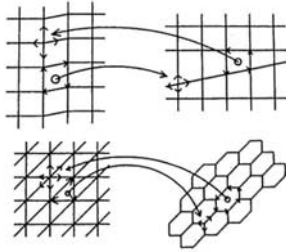

Fig.5.5. Reciprocal surfaces. [Williams 1986]

(lumped masses applied in the centroid of the blocks) that are being taken into consideration for the analysis.

In general there is a lot of work to be done in understanding the three-dimensional behavior of compression structures. Where in two dimensions thrust lines can explain or help to understand possible (even probable) collapse mechanisms, such an interesting link has still to be shown in three dimensions. This task is much harder. Many more variations of collapse are possible to occur. Also here, limit analysis will provide the theoretical framework to understand collapse. As seen in the modern (plastic) analysis for plates using yield lines, many possible failure modes need to be examined.

Another way to make these tools more flexible and valuable is to integrate them into a larger, automated process to analyze existing vaulted structures. I will describe a possible analysis procedure<sup>21</sup> for existing structures:

- a. Do a point cloud survey of the structure to capture its geometry. [Louden 2003] Often some assumptions will have to be made concerning the thickness of the vault/ribs, level of fill/rubble and other black zones not covered by the laser. A GPS system might solve this, but it tends to be rather expensive.
- b. Translate this point cloud information into a usable three-dimensional CAD-model. Algorithms need to be developed that extract the relevant points for a structural analysis from the millions of points produced by a point-cloud survey.
- c. Choose possible loading directions, to make smart cuts (cf. 2.5). It is important to recognize cracks and other pathologies to make good choices. This step can be semi-automated, restricting the user only to options that are physically possible, e.g. no paths should go perpendicular to open cracks.
- d. Run a script that divides the structure into strips (= slicing technique) and the geometry is exported in the format necessary for the thrust line analyses.
- e. Do a 2-d analysis for every strip.
- f. Plug these local analyses back into the 3d CAD model and visualize them in the vault.

To simplify and speed up steps (a) and (b), we can imagine different alternatives using a plan representation of the building, which is easy to get, in combination with software that recognizes structural elements and generates a three-dimensional generic shape that can be updated to represent the actual structure [Chassagnoux et al, 2001] or in

<sup>21</sup> This process is influenced by a conversation with Dr. Pierre Smars. He described his methodology used to analyze several case studies in his PhD dissertation [Smars, 2000]. It is completed with my own ideas, comments and remarks.

Equilibrium systems.  
Studies in masonry structure.

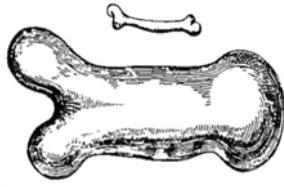

**Fig.5.6.** Galileo's drawings, explaining the influence of scaling up a structure optimized for stresses.

combination with images, using photogrammetry or image-based-modeling. These areas need maybe even more research and development but "a dream scenario would be to walk in a church, take the main dimensions of the building, take some pictures with a digital camera and have the analysis automatically coupled to these."<sup>22</sup>

Step (e) is a series of isolated and static analyses in Smars' process. It is important to not only add interactivity to this step but also to show the global implications of changes to the thrust line in the local analyses, preferably immediately in a three-dimensional realm. Basically, step (e) and (f) should not be discrete but integrated.

Not only for historic structures, but also for new designs, basic static equilibrium is the most important principle. In modern design this is often neglected. I think limit state analysis, or thrust line analysis more specific, would be very valuable for new design as well. A challenge here is that when we work with new efficient materials, scaling the problems is not possible anymore (Fig. 5.6), since stresses do not scale linearly. The equilibrium shapes are correct, but how to assign material to them becomes now an issue. Not only stability, but also material stresses including buckling of compression elements will have to be checked.



**Fig.5.7.** Guastavino vaulting in the "Oyster Bar", Grand Central Station in NYC.

Such an approach would not optimize all structures nor promote Gaudiesque architecture, but would help to understand good structural form and to make better structural decisions when designing. On the other hand, there is a real interest in masonry vaults. Some architects recognize the intrinsic beauty of these structures and want to create new forms with bricks rather than building only traditional walls. As an example, beautiful thin tiled vaults by Rafael Guastavino are often celebrated and accentuated with light (Fig. 5.7).

<sup>22</sup> Quote by John Ochsendorf (January, 2005).

Equilibrium systems.  
Studies in masonry structure.

This thesis has shown that there is tremendous potential in using interactive thrust line analysis for masonry structures. Maybe more importantly, it has raised new research questions to be developed and has given possible paths to be considered for further exploration and development. There is a lot of work left to be done, and this thesis is a small first step towards better analyses (and design) tools for (compression) structures.

The web-based tutorial at least hopes to bring an alternative view to the analyses of historic structures to a wider audience and to explain in a simple manner the behavior of these structures. The pedagogical aspect was very important throughout the entire research process.

Finally, the thesis showed how computers and computation offer new possibilities to an ancient field of research. Equilibrium approaches were for a long time forgotten, but I hope this thesis will help to revive this important and interesting field of study.

**“This is exactly what great minds such as Gaudi or Maillart would be working on today if they would come back and use our modern computers for structural design.”<sup>23</sup>**

---

<sup>23</sup> Quote by John Ochsendorf (March, 2005).

## 6. Appendices

### 6.1 References

- Boothby, T.E.** (2001) "Analysis of masonry arches and vaults," *Progress in Structural Engineering and Materials*, Vol. 3, pp. 246-256.
- Chassagnoux A., Guena F., Untersteller, L.P.** (2001) "Calcul de voûtes d'ogives : modélisation géométrique et calcul par éléments volumiques," *IPSI – Phi2AS*, Vol. 25, n°2, pp. xx-xx.
- Croci, G.** (1998) "The Basilica of St. Francis of Assisi after the September 1997 earthquake," *Structural Engineering International*, January, pp. 56-58.
- Culmann, K.** (1866) *Die graphische Statik*. Zürich, Meyer und Zeller.
- Dupuit.** (1870). *Traité de l'équilibre des voûtes et de la construction des ponts en maçonnerie*. Paris, Dunod Editeur.
- Gauthey, E. M.** (1809). *Traité de la construction des ponts*. 2 volumes, Paris, F. Didot. (2nd ed., 1832; 3rd ed., 1843).
- Giuffrè, A.** (1986). *La stabilità delle strutture: i muri di sostegno, gli archi, le volte*. Roma, Edizione NIS.
- Heyman, J.** (1966) "The stone skeleton," *International Journal of Solids and Structures*, Vol. 2, pp. 249-279.
- Heyman, J.** (1968) "On the rubble vaults of the middle ages and other matters," *Gazette des Beaux-Arts*, 71, pp. 177-188
- Heyman, J.** (1972) *Coulomb's Memoir on Statics: An Essay in the History of Civil Engineering*. Cambridge, Cambridge University Press.
- Heyman J.** (1982) *The Masonry Arch*. Chichester, Ellis Horwood.
- Heyman, J.** (1983) "Chronic defects in masonry vaults: Sabouret's cracks," *Monumentum*, Vol. 26, pp. 131-141. (Reproduced in Heyman, J., *Arches, Vaults, and Buttresses: Collected Essays*, Aldershot: Variorum, Ashgate Publishing, 1996.)
- Heyman, J.** (1988) "Poleni's problem," *Proceedings of the Institution of Civil Engineers*, Vol. 84, pp. 737-759.
- Heyman, J.** (1993) "The collapse of stone vaulting," *Structural Repair and Maintenance of Historical Buildings III*, C.A. Brebbia and R.J.B. Frewer

Equilibrium systems.  
Studies in masonry structure.

(Eds.), Southampton: Computational Mechanics Publications, pp. 327-338.

**Heyman, J.** (1995) *The Stone Skeleton: Structural engineering of masonry architecture*. Cambridge, Cambridge University Press.

**Heyman, J.** (1998) "Structural Analysis: A historical approach." Cambridge, Cambridge University Press.

**Huerta, S., López, G.** (1997) "Stability and consolidation of an ashlar barrel vault with great deformations: the church of Guimarei," *Structural Studies, Repair and Maintenance of Historical Buildings*. C.A. Brebbia and R.J.B. Frewer (Eds.), Southampton: Computational Mechanics Publications, pp. 587-596.

**Huerta, S.** (2001) "Mechanics of masonry vaults: The equilibrium approach," *Proceedings of Historical Constructions*. Lourenço, Roca (Eds.), Guimarães.

**Huerta, S.** (2004) *Arcos bóvedas y cúpulas. Geometría y equilibrio en el cálculo tradicional de estructuras de fábrica*. Madrid, Instituto Juan de Herrera.

**Kilian, A., Ochsendorf, J.A.** (2005) "Particle-spring systems for structural form finding," *Journal of the International Association for Shell and Spatial Structures: IASS*, August 2005.

**Lévy, M.** (1888) *La Statique Graphique et ses Applications aux Constructions*. Paris, Gauthier-Villars.

**Louden, E.I.** (2003) "Use of the Three-Dimensional Laser Scanner as a Documentation Tool at the Statue of Liberty, and Diverse Historic Sites," *HABS 70th Anniversary Symposium: Technology and Architectural Documentation*, November 15, 2003.

**Mainstone, M.J.** (1998). *Developments in Structural Form*. Oxford, Architectural Press.

**Milankovitch, M.** (1907) "Theorie der Druckkurven," *Zeitschrift für Mathematik und Physik*, Vol. 55, pp. 1-27.

**Moseley, H.** (1833) "On a new principle in statics, called the principle of least pressure," *Philosophical Magazine*, Vol. 3, pp. 285-288.

**Nikolinakou, M.A., Tallon, A.J., Ochsendorf, J.A.** (2005) "Structure and form of early Gothic flying buttresses," *Revue européenne de Génie Civil* (Submitted for review March 2005).

Equilibrium systems.  
Studies in masonry structure.

**Ochsendorf, J.A.** (2002) "Collapse of masonry structures," Ph.D. dissertation, Department of Engineering, Cambridge University, June 2002.

**Ochsendorf, J.A., Huerta, S., Hernando, J.I.** (2004) "Collapse of masonry buttresses." *Journal of Architectural Engineering*, ASCE 2004; 10:88-97.

**O'Dwyer, D.** (1999) "Funicular analysis of masonry vaults," *Computers and Structures*, Vol. 73, pp. 187-197.

**Oppenheim, I.J., Gunaratnam, D.J., Allen, R.H.** (1989). "Limit state analysis of masonry domes," *Journal of Structural Engineering*, Vol. 115, No. 4, April, 1989, pp 868-882.

**Pirard, A.** (1967) *La statique graphique*. Paris, Editions Dunod.

**Poleni, G.** (1748) *Memorie istoriche della Gran Cupola del Tempio Vaticano*. Padova.

**Rubiò Bellver, J.** (1913) "Dificultats per arribar a la síntesis arquitectònica," *Anuario de la Asociación de Arquitectos de Cataluña*, pp. 63-79.

**Sabouret, V.** (1928) "Les voûtes d'arrêtes nervures. Rôle simplement décoratif des nervures," *Le Génie Civil*, Vol. 92, pp. 205-209.

**Smars, P.** (2000) "Etudes sur la stabilité des arcs et voûtes," Ph.D. dissertation, Catholic University in Leuven, Belgium, March 2000.

**Williams, C.J.K.** (1986) "Defining and designing curved flexible tensile surface structures," *The mathematics of surfaces*, J.A. Gregory (Ed.), Oxford, Clarendon Press, pp. 143-177.

**Wolfe, W.S.** (1921) *Graphical analysis: a handbook on graphic statics*. New York, McGraw-Hill Book Company.

**Zalewski, W., Allen, E.** (1998) *Shaping Structures*. New York, John Wiley & Sons.



## 6.2. Web references

- [A] **ArchieM**, Obvis Ltd, UK. <http://www.obvis.com/>
- [B] **RING**, CLADU, University of Sheffield, UK.  
<http://www.shef.ac.uk/ring/>
- [C] **InteractiveThrust**, Philippe Block, MIT.  
<http://web.mit.edu/masonry/interactiveThrust/>
- [D] **Active Statics**, Simon Greenwold & Edward Allen, MIT.  
<http://acg.media.mit.edu/people/simong/statics/data/index.html>
- [E] **Cabri Geometry II Plus**, Cabrilog sas, France. <http://www.cabri.com/>
- [F] **Romanesque Architecture of the Bourbonnais**, Columbia University. <http://www.mcah.columbia.edu/bourbonnais/>
- [G] **CADenary**, Axel Kilian, MIT.  
<http://destech.mit.edu/akilian/projectpages/cadenary.html>

## 6.3. “InteractiveThrust”, a web-based tutorial

From the beginning, one of the main goals and challenges was to provide web-based, freely available tools and tutorials for structural analysis of masonry structures. It is important to open up the research as wide as possible since the thesis proposes and promotes a new approach to analyze masonry structures, based on limit state analysis instead of the established finite element analysis methods. During the research and developments of the tools, it was important and valuable to have prototypes of them available online for others to use and provide comments and feedback. For that reason, <http://web.mit.edu/masonry> was launched in January 2005.<sup>24</sup>

---

<sup>24</sup> The site started of as portfolio of this research and is now updated to serve as the “masonry research group” website at MIT.

Equilibrium systems.  
Studies in masonry structure.

**Fig.6.1.** Homepage of the masonry research webpage, linking to and featuring this research.

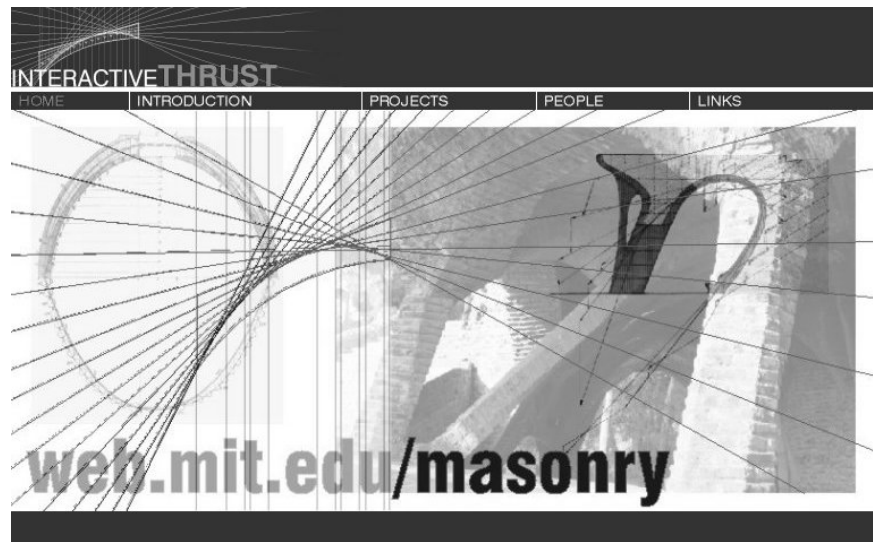

Online at [C] a web-based tutorial provides interactive applets with user guidelines and comments, teaching and explaining the basics of the structural behavior of masonry structures.