

TOPOGRAPHICAL BIBLIOGRAPHY OF
ANCIENT EGYPTIAN HIEROGLYPHIC
TEXTS, RELIEFS, AND PAINTINGS

IV. LOWER AND MIDDLE EGYPT

(Delta and Cairo to Asyût)

BY

The Late BERTHA PORTER

AND

ROSALIND L. B. MOSS, HON. D. LITT. (OXON.), F.S.A.

GRIFFITH INSTITUTE
ASHMOLEAN MUSEUM OXFORD

First published 1934
by the Clarendon Press Oxford
Re-issued by the Griffith Institute
1968

REPRINTED LITHOGRAPHICALLY IN OXFORD
BY ALDEN & MOWBRAY LTD AT THE ALDEN PRESS
FROM SHEETS OF THE FIRST EDITION SET AND
PRINTED AT THE UNIVERSITY PRESS, OXFORD

CONTENTS

List of Plans	xix
Introductory Note	xxi
List of Abbreviations	xxiv
List of Collections of Manuscripts	xxvii

I. NORTHERN DELTA

NORTH COAST

El-'Arish to Alexandria.

El-'Arish	1
Tell Faramâ (Pelusium)	1
Tell el-Makhzan	1
Damietta	1
Tell el-Ash'âr	1
Rosetta	1
Idku	2
Abû Qîr (Canopus)	2
Temple of Isis	2
Miscellaneous	2
Alexandria	2
West Harbour	2
Serapeum	3
Found near East Harbour	3
Mosque of St. Athanasius	3
Arsinoeion	4
Kôm el-Damâs	4
Caesareum	4
Nicomolis	5
Miscellaneous	5
Near Lake Maryût (Mareotis)	6
Kurûm el-Ṭuwâl	6

EAST PART

A. El-Qanṭara to Şaft el-Hinna.

El-Qanṭara	6
Tell Abû Seifa	6
Cemetery	7
Tell Dafana (Daphnae)	7
Central Fort	7

Enclosure Wall on north	7
Camp	7
Miscellaneous	7
El-Munâgât el-Kubra	7
Nabêsha (Tell Far'ûn)	7
Temple of Goddess Buto	8
Great Temple	8
Small Temple of Amasis	8
Cemetery	8
Town	9
Miscellaneous	9
Gumaŷyima	9
Temenos and Temple	9
Khatâ'na	9
Remains of Temple	9
Qantir	9
Palace of Sethos I	9
Workshops	9
Miscellaneous	10
Kôm Sheikh Razîq	10
El-Ṭawîla	10
El-Dimeiyîn	10
El-'Awâsga	10
Şaft el-Hinna (Phacusa)	10
Temple of Sopt	10
Cemetery	11
Miscellaneous	11
B. Maṭariya to Tell Başa (Bubastis).	
Maṭariya	13
Tell Tennis	13
Şân el-Ḥagar (Tanis)	13
Great Temple	13
Subsidiary Buildings	23
Ptolemaic Chapel	23
Temple of Anta	24
Building of Ptolemy IV Philopator	25
South Gate	25
Private Houses, north-east of South Gate	25
South Temple	25
East Temple	25
Private Houses, east of Great Temple	26

CONTENTS

vii

Miscellaneous	26
Hurbeit̄ (Pharbaethos)	26
El-Rebâ'iyin (Rebaï)	27
Abû Yâsin	27
Ṭûkh el-Qarâmûş	27
Temple	27
Finds	27
Tell Başta (Bubastis)	27
Great Temple	27
Small Temple	32
Tomb of Ḥori	32
Miscellaneous	32
C. Timai el-Amdîd to Tell el-Muqdâm.	
Timai el-Amdîd (Mendes and Thmuis)	35
Tell el-Rub' (Mendes)	35
Temple	35
Ram-Cemetery	36
Tombs	36
Tell Timai (Thmuis)	36
Miscellaneous	36
El-Simbillâwein	37
Mit Gharîṭa	37
Tell Ṭambûl	37
Tell el-Muqdâm (Leontopolis).	37
Finds	37
Tomb. Dyn. XXII (?)	39
Mit Ya'îsh	39
El-Bûha	39
Dundîṭ	39

CENTRAL PART

A. Damietta Branch of the Nile. Tell Balala to Zifta.	
Tell Balala (Tell 'Tebilla')	39
Tell Baqlîya (Hermopolis Parva)	39
Tell el-Naqûs	39
Miscellaneous	40
Near Tell Baqlîya	40
Bilgâi	40
Bahbit el-Higâra (Iseum)	40
Temple of Isis	40
Miscellaneous	42

Bânûb	42
El-Maḥalla el-Kubra	42
Kôm el-Shatâyin	43
Samannûd (Sebennytos)	43
Temple of Onuris-Shu	43
Finds	43
Abû Şir (Busiris)	44
Zifta	44
Tell Umm Ḥarb or Tell Muşţâi	44
Temple of Thoth.	44
B. Between Damietta and Rosetta Branches of the Nile.	
Ma'şara	45
Kôm Ibshân	45
Sakha (Xoïs)	45
Kafr Matbûl	45
Tell el-Farâ'in or Ibţu (Buto)	45
Tida	45
Tanţa	45
Maḥallet Marḥûm	46
El-Bindaria	46
<i>WEST PART</i>	
A. Rosetta Branch of the Nile.	
Şâ el-Ḥagar (Saïs)	46
Royal Tombs in Temple-enclosure	46
Miscellaneous	46
Ganâg	49
El-Naḥḥâriya	49
B. West of Rosetta Branch of the Nile.	
Damanhûr	49
El-Barnûgi	49
Kôm Gi'eif, El-Nibeira, and El-Niqrâsh, (Naucratis)	50
From Temple	50
C. Western Edge.	
Kôm el-Abqa'ain	50
Kôm Firîn (Kôm Afrin)	50
Kôm el-Ḥiṣn.	51
Temple of Sekhmet-Ḥathor	51
Tomb of Khesu-wer	51

II. FROM THE RED SEA CANAL TO THE NILE

(*Suez to El-Tell el-Kebir*)

Suez	52
Kôm el-Qulzum (Clysma)	52
Ancient Canal from Red Sea to Wâdi Tummilât	52
North of head of Gulf of Suez	52
Between El-Shallûfa and El-Kabrît	52
North of Bitter Lakes	52
Ancient Caravan Route from Red Sea to Wâdi Tummilât	53
Gebel Murr	53
Gebel Abû Hassa	53
Temple of Horus and Ḥathor	53
Wâdi Tummilât	53
Tell el-Maskhûṭa (Pithom)	53
Temple	53
Tell el-Raṭâba	55
Temple of Atum (?)	55
El-Tell el-Kebîr	55
Tell Ṣamad	55

III. SOUTHERN DELTA

EAST PART

Bilbeis to Cairo.

Bilbeis	55
Temple of Nektanebos II	55
El-Shaghâmba	56
Town and Fort	56
Ghîta or Tell Yehud	56
Town and Fort	56
Cemetery	56
Tell el-Yahûdiya (' Heliopolitan Leontopolis ')	56
Hyksos Camp	56
Temple of Ramesses II	56
Temple of Ramesses III	56
Town and Temple of Onias	57
Main Cemetery	57
Jewish Cemetery	57
Desert Cemetery	57
Miscellaneous	57
El-Shôbak	58

Nûb Ṭaḥa	58
El-Khânka	58
Siryâqûs	58
Musturud	58
Bahtim	58
Heliopolis	59
El-Marg	59
Tomb of Pethenfi	59
Various	59
El-Khuşûş	59
Bull-Cemetery	59
Various	60
Tell Hişn	60
Great Enclosure	60
Tombs of the High priests of Heliopolis	61
House. About Dyn. XXIII	62
El-Maṭariya	62
Tombs	62
Various	62
'Ezbet el-Zeitûn	62
Manshiyet el-Şadr	62
Qubbet Taufiq	62
Miscellaneous	63
El-Gebel el-Aḥmar	65

CENTRAL PART

A. Athribis to El-Barâd'a.

Benha with Tell Atrîb (Athribis)	65
Cache of Treasure	65
Tomb of Pefteuamûn	65
Miscellaneous	65
Kafr Manâqir	67
Kôm el-Aḥmar	67
Ṭûkh el-Malaq	67
Qaha	67
El-Barâd'a	67

B. Zâwyet Razîn to Gireis.

Zâwyet Razîn	67
Gireis	67
Ashmûn	67

WEST PART

Terenuthis to Letopolis.

Kôm Abû Billo (Terenuthis)	67
Temple	68
Wardân	68
El-Qaṭṭa	68
Middle Kingdom Tombs	68
Ausîm (Letopolis)	68
Temple of Horus	68

IV. CAIRO

Monuments and re-used blocks found in the City	69
South of Old Cairo (El-Fuṣṭât)	73
Remains of Temple	73
On the Cairo-Suez Road	73

V. BETWEEN CAIRO AND EL-FAIYÛM

*(Tura to Maidûm)**EAST BANK*

Ṭura and El-Ma'şara	74
Ṭura Quarries	74
El-Ma'şara Quarries	74
Ṭura Cemetery	75
El-Minya and El-Shurafa	75
Roman Fort, Town, and Cemetery, and Ptolemaic Cemetery	75
Atfîḥ (Aphroditopolis)	75
Cemetery	75
Finds	76

WEST BANK

Mazghûna	76
North Pyramid. Possibly Sebekneferurē'	76
South Pyramid. Possibly Amenemḥēt IV	76
Necropolis south of South Pyramid	77
El-Dinnâwiya	77
Pyramid Field of El-Lisht	77
North Pyramid. Amenemḥēt I	77
South Pyramid. Sesostri I	81
Miscellaneous	85

Kafr 'Ammâr and Ṭarkhân	85
Cemeteries and Mastaba-field	85
Temple	86
El-Girza and El-Riqqa	86
Necropolis	86
Maidûm	89
Pyramid. Snefru	89
Necropolis	90
North Mastaba-field	90
South Mastaba-field	94
Other Cemeteries	94
Miscellaneous	95

VI. EL-FAIYÛM

Kôm el-Asl (Bacchias)	96
Temple	96
Kôm Aushim (Karanis)	96
Temple	96
Town	96
Finds	96
Dimai (Soknopaiou Nēsos)	96
Temple of Soknopaios	96
Finds	96
Temple of Qaşr el-Sâgha	97
Medînet Qûta (El-Yaûta)	97
Town	97
Qaşr Qârûn	97
Temple. Late Ptolemaic	97
Baṭn Ihrît (Theadelphia)	98
Temple of Pnepherôs	98
Finds	98
Biyahmu	98
Colossi of Amenemḥêt III	98
Medînet el-Faiyûm (Crocodylopolis-Arsinoë)	98
Temple of Sobk	98
Finds	98
Abgîg or Begîg	99
Obelisk of Sesostris I	99
Hawâra (Hauwâret el-Maqta')	100
Pyramid. Amenemḥêt III	100
Labyrinth. Amenemḥêt III	100

CONTENTS

xiii

Cemeteries north of Pyramid	101
Crocodile-Cemetery	102
Roman Cemetery	103
Seila	103
Pyramid. Dyn. III (?)	103
Finds	103
Tell Umm el-Breigât (Tebtunis)	103
Temple	103
Town	103
Finds	103
Miscellaneous	103

VII. BETWEEN EL-FAIYÛM AND BENI ḤASAN

(*Abûšîr el-Malaq to Zâwyet el-Maiyitîn*)

WEST BANK

Abûšîr el-Malaq	104
Temple of Ptaḥ-Sokari-Osiris	104
Cemetery	105
El-Ḥaraga	105
Cemeteries	105
El-Lâhûn	107
Pyramid. Sesostri II	107
Necropolis	110
Town ('Kahûn')	111
Miscellaneous	112
Kôm Medînet Ghurab ('Gurob')	112
Temple of Tuthmosis III	112
Small Cult-temple of Tuthmosis III	113
Palace (?)	113
Town	113
Necropolis	114
Miscellaneous	115
Sidmant (El-Gebel)	115
Necropolis	115
Finds	118
Ihnâsya el-Medina (Heracleopolis Magna)	118
Temple of Ḥarsaphes	118
Kôm el-'Aqârib	119
Destroyed Temple	119
Miscellaneous	121

Dishâsha	121
Cemetery	121
Finds	123
Kafr Abû Shahba	123
El-Gamhûd	124
Cemetery	124
El-Bahnasa (Oxyrhynchus)	124
City and Cemeteries	124

EAST BANK

El-Ĥîba (Ankyronpolis?)	124
Temple	124
Town-site	124
Cemetery	125
El-Kôm el-Aḥmar Sawâris	125
Cemetery	125
Temple	126
El-Sheikh Fadl	126
El-Sirîriya	126
Rock-chapel of Ḥathor of 'Akhwi	126
Rock-stela	127
Gebel el-Teir	127
Ṭihna (Tēnis or Acōris)	127
Temples	129
Necropolis	130
Rock-stelae	130
Rock-cut Mastabas (' Fraser Tombs ')	131
Sheikh Mubârik	133
Fortress	133
Finds	133
Found near El-Minya	133
Zâwyet el-Amwât (or el-Maiyitn) and El-Kôm el-Aḥmar	134
Step Pyramid. Dyn. III (?)	134
Necropolis	134
Miscellaneous	139

VIII. BENI ḤASAN AND SPEOS ARTEMIDOS

Beni Ḥasan	141
Necropolis	141
Rock-tombs. Dyn. XII	141
Tombs of Officials. Dyn. VI-XII	161

CONTENTS

xv

Nuêrât	163
South Beni Hasan	163
Iṣṭabl 'Antar (Speos Artemidos)	163
Great Speos	163
Small Speos	165
Rock-tomb	165
Rock-stela	165

IX. BETWEEN BENI-HASAN AND EL-'AMARNA

(*Balanşûra to El-Sheikh Sa'id*)

WEST BANK

Balanşûra	165
Necropolis	165
El-Ashmûnein (Hermopolis Magna)	165
Temple of Thoth. Alexander the Great and Philip	165
Temple of Thoth. Dyn. XIX	167
Middle Kingdom Temple	168
Late Gate	168
Temple of Ramesses II.	168
Finds	168
Tûna (Tanis Superior)	169
Necropolis of Hermopolis Magna	169
Tomb of Pedusiri	169
Tomb of Pedekakem, &c.	174
Finds	174
Mallawi	175

EAST BANK

El-Sheikh 'Ibâda (Antinoë or Antinoupolis)	175
Chapel of Amenophis IV	175
Temple of Ramesses II	175
Temple of Isis	176
Temple of Serapis	176
Necropolis	176
Deir el-Bersha	177
Great Rock-tombs	177
Old Kingdom Tombs	183
Middle Kingdom Tombs	183
Rock-stelae	185
Miscellaneous	185

El-Sheikh Sa'id	187
Rock-tombs	187
Cemeteries near Sheikh Zibeida	192

X. EL-'AMARNA AND HET-NUB

El-'Amarna	192
City of Akhetaten	193
Great Gate	193
Palace of Nefertiti (?)	193
North Palace	193
Great Temple	195
Smaller Temple	197
Great Official Palace	197
Private Palace	199
Records Office	199
Town	199
River Temple	207
Palace called Maru-Aten	208
Desert Altars	208
Workmen's Village	209
Tomb chapels	209
Rock-tombs	209
North Group	209
South Group	219
Boundary Stelae	230
Miscellaneous	232
Royal Tomb	235
Quarries	237
Het-nub	237
Alabaster Quarries	237

XI. BETWEEN EL-'AMARNA AND ASYÛṬ

(Sheikh 'Aṭīya to Maṅqabād)

EAST BANK

Sheikh 'Aṭīya	239
Qūṣeir el-'Amarna	239
Rock-tombs	239
Temple of Ḥaṭḥor	241
Gebel Abû Fôda	241
Quarries	241

Darb el-Karaïb	241
Rock overlooking Nile	241
El-Ma'âbda	241
Grotto	241
Rock-tomb	241
Deir el-Gabrâwi	242
Rock-tombs	242
El-Aṭâwla	246
Temple	246
Cemetery	247
Biṣra	247
Alabaster Quarries	247

WEST BANK

Meir	247
Rock-tombs	247
Miscellaneous	256
El-Qûṣiya (Cusae)	258
Sites south of Meir	258
El-Tatâliya	258
Necropolis	258
Dara	258
Brick Pyramid of King Khui	258
Mastaba south of Pyramid	259
Tomb west of Pyramid	259
El-'Atâмна	259
Rock-tombs	259
Masra'	259
Necropolis	259
Manqabâd	259
Destroyed Temple (?)	259
Necropolis	259

XII. ASYÛṬ AND DEIR DURUNKA

Asyûṭ (Lycopolis)	259
Temple	259
Necropolis	259
Rock-tombs	259
Tombs at top of hill, north end	265
Found in débris of later cemetery	265

Miscellaneous	267
Deir Durunka	269
Necropolis	269
Miscellaneous	269
Addenda	270
Maps	271
Index	
Kings, Periods [&c.]	277
Private Names	280
Divinities	288
Geographical	289
Various	294

LIST OF PLANS

Key-map.		. xxviii
Şân el-Ḥagar (Tanis).	Key-plan	12
El-Lisht.	North Pyramid	78
	South Pyramid	80
Maidûm.	Key-plan	88
El-Lâhûn.	Pyramid	106
	Key-plan	108
Dishâsha.	Tombs (Inti, Iteti)	120
El-Kôm el-Aḥmar Sawâris.	Tomb (Pepy-'ankh)	120
El-Sirîriya.	Rock-chapel	120
Gebel el-Teir.	Tomb (Iymery)	120
Ṭihna.	Key-plan	128
	Roman Temple, Temple of Nero, Graeco-Roman Chapel	128
	Tombs (Neka-'ankh [1st and 2nd Tombs], Khenuka).	132
	El-Kôm el-Aḥmar. Tombs (Khunes, Ni-'ankh-Pepy, Nefersekheru)	132
Beni Ḥasan.	Tombs (Amenemḥêt, Khnemḥotp III, Khnemḥotp II, Khnemḥotp I)	140
	Tombs (Baḳt III, Khety, Baḳt I, Baḳt II)	150
Işṭabl 'Antar (Speos Artemidos).	Great Speos	150
El-Ashmûnein.	Key-plan	166
Tûna.	Tomb (Pedusiri)	170
El-Sheikh 'Ibâda (Antinoë).	Temple of Ramesses II	170
Deir el-Bersha.	Tombs (Dḥutinakht VI, Dḥutiḥotp II, 'Aḥanakht)	178
El-Sheikh Sa'id.	Tombs (Serfka, Werirni)	186
	Tombs (Meru, Wiu, Meru and Ḥenent, Teti-'ankh, Ḥepi)	190
El-'Amarna.	Key-plan	194
	Town	196
	Tombs (Ḥuya, Meryrē' II, Aḥmosi, Meryrē' I, Penthu, Paneḥesi)	210
	Tombs (Parennûfer, Tutu, Ma'ḥu, Ra'mosi, Mey)	220
	Tombs (Any, Ay), Royal Tomb	226
Quşeir el-'Amarna.	Tombs (Pepy-'ankh, Khuenekh)	240
Deir el-Gabrâwi.	Tombs (Henḳu, Rē'-ḥem, Ibi, Za'u)	240
Meir.	Tombs (Pepy-'ankh, Senbi [B 1], Ukh-ḥotp [B 2], Senbi [B 3])	248

Meir.	Tombs (Ukh-hotp [B 4], Ukh-hotp [C 1], Pepy- 'ankh-ḥir-ib)	252
Asyût.	Tombs (Ḥepzefa I, Tef-ibi, Khety II, Ḥepzefa III)	260
Map I.	Delta. (Sections I-IV)	271
Map II.	Cairo to Ihnâsya el-Medîna. (Sections V and VII)	272
Map III.	El-Faiyûm. (Section VI)	273
Map IV.	Ihnâsya el-Medîna to Zâwyet el-Maiyitin. (Sec- tion VII)	274
Map V.	Zâwyet el-Maiyitin to Asyût. (Sections VIII- XII)	275

NOTE

This Bibliography takes note only of original copies and publications, and does not include secondary reproductions and discussions. Finds of small objects are not recorded except in very special cases.

INTRODUCTORY NOTE

THE sites dealt with in the present volume are those in the Delta with the Wâdi Tummilât as far as Suez, and in the Nile Valley from Cairo to Asyût including the Faiyûm. The Memphite necropolis extending from Abû Rawâsh to Dahshûr is excluded as it has already been published in our third volume.

I-III. The Delta. The arrangement of the Delta presents considerable difficulty. Apart from a few important sites in which the foundations of ancient buildings still remain, such as Nabêsha, Tanis, and Bubastis, most of our material consists of scattered blocks from destroyed temples often far from their original positions, and a variety of stelae and statues of doubtful provenance. It has been found convenient to divide the Delta into three main sections, the northern Delta, the routes from the Red Sea Canal to the Nile, and the southern Delta. In the northern section we begin with the sites along the coast, from El-'Arîsh at the eastern frontier of Egypt to Alexandria in the west, and then deal successively with the eastern, central, and western portions. The second section begins with Suez itself, follows the ancient canal and caravan routes near the Bitter Lakes to the Wâdi Tummilât, and then continues westward to the Nile Valley. The southern section is subdivided into an eastern portion which includes Tell el-Yahûdiya and Heliopolis, a central, and a western portion. All the sites mentioned will be found on Map I at the end of the volume, and also in the geographical index in which the map numbers are indicated.

IV. Cairo. The fourth section of this volume is devoted to Cairo and its immediate neighbourhood. Here the remains consist entirely of blocks from other sites (chiefly Heliopolis and Memphis) re-used in medieval and modern buildings, the presumed provenances being deduced from the inscriptions. They have therefore been arranged in chronological order, though whenever possible we have attempted to indicate where each was actually found, with references to the detailed plan in the *Description de l'Égypte* or to the more accessible plan in Baedeker's Guide. The remains of a Saite temple south of Old Cairo, and a newly discovered Twelfth Dynasty graffito on the road from Cairo to Suez, are also included here.

V-XII. The Nile Valley from Ṭura to Asyût. The Nile Valley is somewhat simpler geographically. As we ascend the river from Cairo, three areas, the Faiyûm, Beni Ḥasan, and El-'Amarna, are sufficiently important to demand sections of their own. Between these we take the sites in geographical order, following the east and west banks alternately. Thus our fifth section deals with the places between Cairo

and the Faiyûm, from Ṭura to Aṭfiḥ on the east bank, and then the line of pyramids from Mazghûna to Maidûm on the opposite side of the river. After the Faiyûm (section VI), we continue along the west bank as far as El-Bahnasa, and then take the eastern sites from El-Ḥiba through Ṭihna to Beni-Ḥasan with Speos Artemidos (section VIII). Between Beni-Ḥasan and El-'Amarna, our ninth section includes Hermopolis Magna on the east, and Antinoë, Deir el-Bersha, and Sheikh Sa'id on the west, the boundary stelae of Amenophis IV at Tûna being reserved for the tenth section which deals with El-'Amarna and Het-nub. In this we begin with the chief temples and palaces in the northern part of the City of Akhetaten, and then deal with remains from private houses from north to south: here we have allowed ourselves a certain latitude, and have included the more important finds from sculptors' studios and other specified houses as well as actual inscriptions and paintings. After this come the more isolated buildings of Maru-Aten and the River Temple at the southern end of the City, and the Desert Altars, Workmen's Village, and Tomb Chapels away to the east; and these are followed by the two groups of rock-tombs, the boundary stelae on either side of the Nile, and a miscellaneous collection of monuments in various museums with no exact provenance. Thence we proceed up the desert wadis to the Royal Tomb and various quarries, and finally to the great alabaster quarries of Het-nub in the eastern desert. Our eleventh section deals with the scattered sites south of El-'Amarna, including the necropolis of Meir on the western bank, after which Asyût forms a final section with the remains of the temple recently discovered in the town itself, and the rock-tombs and necropolis in the cliffs to the south-west.

It must not be forgotten that on certain sites excavations are still proceeding, and new material is continually coming to light, so that it is often impossible to record the latest discoveries. Thus at Tanis the area south of the Great Enclosure is being investigated by M. Montet for the University of Strasbourg; the New York Metropolitan Museum Expedition is still at work at Lisht, and several seasons have been devoted to the necropolis at Maidûm by the Pennsylvania University Museum under the direction of Mr. Rowe. At Tebtunis in the Faiyûm an official Italian expedition under Signor Bagnani is clearing the Ptolemaic Temple, and Professor Roeder and his assistants are making systematic excavations on behalf of the Hildesheim Museum at El-Ashmûnein, while the Egypt Exploration Society is again active at El-'Amarna where the Great Temple discovered by Petrie is now being thoroughly explored.

Two new manuscript sources have been utilized in the present volume. One is the diary of the Count de Saint-Ferriol between 1839 and 1843, to which his heirs through the Abbé Tresson have kindly allowed us to refer. The other is the recently discovered diary of Lepsius in 1844, lent to us with their usual liberality by the authorities of the Berlin Museum, in which the stelae at El-'Amarna are mentioned, though otherwise it is almost entirely devoted to texts from monuments at Thebes which we hope to make use of in an appendix to our Theban volumes.

According to our usual practice, only inscribed, sculptured, or painted monuments are dealt with in this bibliography, ushabti and small objects being omitted; but occasional exceptions have been made in the case of important hoards of jewellery, and general descriptions of excavations. Again, only original copies of reliefs and texts are included, secondary copies, translations, and discussions being outside the scope of the present work, while objects of which the provenance is doubtful, or only assumed from the inscriptions, are generally ignored.

At the end of the volume will be found five maps, in which the places mentioned are marked, the spelling of geographical names followed being that of the Survey Department of Egypt Maps 1: 100,000 scale. There are also indexes of royal and private names, divinities, and geographical sites, with a short miscellaneous index to cover a few other headings. The number of small sites in the Delta has made Map I rather complicated, but in the geographical index the position of each place is shown. For doubtful kings, we have followed the dating given in Gauthier's *Le Livre des Rois*.

Our thanks are specially due to the Department of Antiquities of the Egyptian Government for the facilities afforded us in verifying the monuments on the spot, and to the staffs of the Cairo, British, and Berlin Museums for help in ascertaining the history of objects in their collections. We should also like to express our gratitude to the excavators of various sites, who have supplied us with plans and other information, especially to Professor Roeder, Mr. Rowe, Dr. Frankfort, Mr. Pendlebury, and the members of the New York Metropolitan Museum Expedition, and also to Mr. Wainwright, who kindly placed his valuable local knowledge of Middle Egypt at our disposal.

The authors will be grateful if those who make use of this Bibliography will send a note of any omission or error to me at Sandridge, Boar's Hill, Oxford.

R. L. B. M.

OXFORD, *April* 1934.

LIST OF ABBREVIATIONS¹

<i>Abhand. d. Preuss. Akad. d. Wiss.</i>	Abhandlungen der Preussischen Akademie der Wissenschaften.
<i>Ä.Z.</i>	Zeitschrift für ägyptische Sprache und Altertumskunde, 1863, &c.
<i>Aeg. Inschr. Mus. Berlin</i>	Aegyptische Inschriften aus den Königlichen Museen zu Berlin, edited by Gunther Roeder. Vol. i, 3 parts, 1901, 1903, 1904; vol. ii, 1924.
<i>Aeg. und Vorderasiat. Alterthümer</i>	Aegyptische und Vorderasiatische Alterthümer aus den Königlichen Museen zu Berlin, 1895-7. (Verlag Mertens.)
<i>Anc. Eg.</i>	Ancient Egypt (edited by Sir Flinders Petrie), 1914, &c.
<i>Ann. Mus. Guimet</i>	Annales du Musée Guimet.
<i>Ann. Serv.</i>	Annales du Service des Antiquités de l'Égypte, 1900, &c.
<i>Archaeological Report</i>	Archaeological Report comprising the work of the Egypt Exploration Fund and the progress of Egyptology, 1892-1912.
<i>Bibl.</i>	Earlier volumes of this publication.
<i>Bibliothèque Ég.</i>	Bibliothèque égyptologique contenant les Œuvres des Égyptologues français . . . publiée sous la direction de G. Maspero, 1893, &c.
BISSING, <i>Denkmäler</i>	BISSING (FRIEDRICH WILHELM VON), Denkmäler Aegyptischer Sculptur, 1911.
<i>Boston Mus. Bull.</i>	Bulletin of the Museum of Fine Arts, Boston.
BREASTED, <i>Anc. Rec.</i>	BREASTED (JAMES HENRY), <i>Ancient Records of Egypt</i> , 5 vols., 1906-7.
BRUGSCH, <i>Dict. Géog.</i>	BRUGSCH (HEINRICH), Dictionnaire géographique de l'ancienne Égypte. 2 vols., 1879-80.
BRUGSCH, <i>Geogr. Inschr.</i>	BRUGSCH (HEINRICH), Geographische Inschriften altägyptischer Denkmäler. 3 vols., 1857, 1858, 1860.
BRUGSCH, <i>Monumens</i>	BRUGSCH (HEINRICH), Monumens de l'Égypte, 1857.
BRUGSCH, <i>Recueil</i>	BRUGSCH (HEINRICH), Recueil de Monuments égyptiens. Vol. i, 1862-3.
BRUGSCH, <i>Thes.</i>	BRUGSCH (HEINRICH), Thesaurus Inscriptionum Aegyptiacarum, 1883-84.
<i>Bull. Inst. Ég.</i>	Bulletin de l'Institut égyptien, 1859-1918, continued as Bulletin de l'Institut d'Égypte, 1919, &c.
<i>Bull. Inst. Fr. Arch. Or.</i>	Bulletin de l'Institut français d'Archéologie orientale du Caire, 1901, &c.
CAPART and WERBROUCK, <i>Memphis</i>	CAPART (JEAN) and WERBROUCK (MARCELLE), <i>Memphis à l'ombre des Pyramides</i> , 1930.
<i>Cat. Caire</i>	Catalogue général des Antiquités égyptiennes du Musée du Caire.
CHAMPOLLION, <i>Mon.</i>	CHAMPOLLION (J. F.), <i>Monuments de l'Égypte et de la Nubie</i> . 4 vols., 1835-45.
CHAMPOLLION, <i>Not. Descr.</i>	CHAMPOLLION (J. F.), <i>Monuments de l'Égypte et de la Nubie</i> . Notices descriptives. 2 vols., 1844-79.
<i>Comptes Rendus</i>	Académie des Inscriptions et Belles-Lettres. <i>Comptes Rendus</i> .

¹ An asterisk (*) in the letter-press denotes a reference to a manuscript. See List on p. xxvii.

- DENON, *Voyage*
Descr. de l'Égypte, Ant.
 DUEMICHEN, *Flotte*
Hiero. Texts [etc.]
 IPPEL and ROEDER, *Denkmäler ... Hildesheim J.E.A.*
 JÉQUIER, *L'Architecture*
 LEGRAIN, *Répertoire*
 LEPSIUS, *Auswahl*
L. D.
L. D. Ergänz.
L. D. Text
 MARIETTE, *Mastabas*
 MARIETTE, *Mon. Div.*
 MARIETTE, *Voyage*
Mém. Inst. Fr. Arch. Or.
Mém. Miss. Arch. Fr.
 MEYER, *Darstellungen der Fremdvölker Mitteil. d. deutsch. Inst. Kairo.*
Mitteil. d. Deutsch. Or. Gesell.
Monuments Piot
- DENON (VIVANT), *Voyage dans la Basse et la Haute Égypte*, ed. 1802.
 Description de l'Égypte ou Recueil des Observations et des Recherches qui ont été faites en Égypte pendant l'Expédition de l'Armée française. Antiquités (Planches). 5 vols., 1809-22. État Moderne (Planches). 2 vols., 1822-3.
 DUEMICHEN (JOHANNES), *Die Flotte einer aegyptischen Koenigin*, 1868.
 Hieroglyphic Texts from Egyptian stelae, &c., in the British Museum. Pts. 1-7, 1911-25.
 IPPEL (ALBERT) and ROEDER (GUNTHER), *Die Denkmäler des Pelizaeus-Museums zu Hildesheim*, 1921.
 Journal of Egyptian Archaeology published by The Egypt Exploration Society, 1914, &c.
 JÉQUIER (GUSTAVE), *L'Architecture et la Décoration dans l'ancienne Égypte*. 3 vols., 1922-4.
 (Vol. i) *Les Temples memphites et thébains des Origines à la XVIII^e Dynastie*.
 (Vol. ii) *Les Temples ramessides et saïtes de la XIX^e à la XXX^e Dynastie*.
 (Vol. iii) *Les Temples ptolémaïques et romains*.
 LEGRAIN (GEORGES), *Répertoire généalogique et onomastique du Musée du Caire*, 1908.
 LEPSIUS (RICHARD), *Auswahl der wichtigsten Urkunden des aegyptischen Alterthums*, 1842.
 LEPSIUS (RICHARD), *Denkmäler aus Aegypten und Aethiopien*. 12 vols., 1849-59.
 LEPSIUS (RICHARD), *Denkmäler aus Aegypten und Aethiopien, Ergänzungsband*, 1913.
 LEPSIUS (RICHARD), *Denkmäler aus Aegypten und Aethiopien, Text*, 1897, &c.
 MARIETTE (AUGUSTE FERDINAND), *Les Mastabas de l'ancien Empire*, 1885.
 MARIETTE (AUGUSTE FERDINAND), *Monuments divers recueillis en Égypte et en Nubie*, 1872, 1879.
 MARIETTE (AUGUSTE FERDINAND), *Voyage dans la Haute Égypte*, 1893.
 Mémoires publiés par les Membres de l'Institut français d'Archéologie orientale du Caire, 1902, &c.
 Mémoires publiés par les Membres de la Mission archéologique française au Caire, 1883, &c.
 MEYER (EDUARD), *Bericht über eine Expedition nach Ägypten zur Erforschung der Darstellungen der Fremdvölker*, 1913.
 Mitteilungen des deutschen Instituts für ägyptische Altertumskunde in Kairo, 1930, &c.
 Mitteilungen der deutschen Orient-Gesellschaft zu Berlin, 1899, &c.
 Fondation Piot, *Monuments et Mémoires publiés par l'Académie des Inscriptions et Belles-Lettres*.

- N.Y. Metro. Bull.* Bulletin of the Metropolitan Museum of Art, New York.
O.L.Z. Orientalistische Literaturzeitung, 1898, &c.
 PIEHL, *Inscr. Hiéro.* PIEHL (KARL), Inscriptions hiéroglyphiques recueillies en Europe et en Égypte. 3 Series, 1886, 1890, 1895.
 PIERRET, *Inscr. du Louvre* PIERRET (PAUL), Recueil d'Inscriptions inédites du Musée Égyptien du Louvre. 2 parts, 1874, 1878.
 PRISSE, *L'Art Égyptien* PRISSE D'AVENNES (A. C. T. É.), Histoire de l'Art égyptien d'après les Monuments, 1878. Texte, 1879.
 PRISSE, *Mon.* PRISSE D'AVENNES (A. C. T. É.), Monuments égyptiens, 1847.
F.S.B.A. Proceedings of the Society of Biblical Archaeology, 1878-1918.
Rec. de Trav. Recueil de Travaux relatifs à la Philologie et à l'Archéologie égyptiennes et assyriennes, 1870, &c.
Rev. Arch. Revue Archéologique, 1844, &c.
Rev. de l'Ég. Anc. Revue de l'Égypte ancienne, 1925, &c.
Rev. Égypt. Revue égyptologique, 1880-1924 (continued as Revue de l'Égypte ancienne).
 ROSELLINI, *Mon. Civ.* ROSELLINI (IPPOLITO), I Monumenti dell'Egitto e della Nubia. Monumenti Civili, 1834.
 ROSELLINI, *Mon. Stor.* ROSELLINI (IPPOLITO), I Monumenti, &c. Monumenti Storici, 1832.
 ROUGÉ, *Album Photo.* ROUGÉ (JACQUES DE), Album photographique de la Mission remplie en Égypte, 1863, 1864.
 ROUGÉ, *Inscr. Hiéro.* ROUGÉ (JACQUES DE), Inscriptions hiéroglyphiques copiées en Égypte pendant la Mission scientifique de M. le Vicomte Emmanuel de Rougé, 1877.
 SETHE, *Urk. i.* SETHE (KURT), Urkunden des Alten Reichs, 1903.
 SETHE, *Urk. ii.* SETHE (KURT), Hieroglyphische Urkunden der griechisch-römischen Zeit, 1916.
 SETHE, *Urk. iv.* SETHE (KURT), Urkunden der 18. Dynastie, 1906-9.
 SHARPE, *Ég. Inscr.* SHARPE (SAMUEL), Egyptian Inscriptions from the British Museum and other sources. 2 Series, 1837, 1855.
Sitzungsb. d. k. Bayer. Akad. d. Wiss. (Phil. hist. Kl.) Sitzungsberichte der Bayerischen Akademie der Wissenschaften. Philosophisch-historische Klasse.
 SPELEERS, *Rec. des Inscr. Ég.* SPELEERS (LOUIS), Recueil des Inscriptions égyptiennes des Musées Royaux du Cinquenaire à Bruxelles, 1923.
Trans. Int. Cong. Or. Transactions of the International Congress of Orientalists, 1873, &c.
Trans. Roy. Soc. Lit. Transactions of the Royal Society of Literature, 1829, 1843.
Trans. S.B.A. Transactions of the Society of Biblical Archaeology, 1872-86.
 WILKINSON, *M. and C.* WILKINSON (J. GARDNER), The Manners and Customs of the Ancient Egyptians. First edition, 3 vols., 1837; 2nd series, 2 vols. and one vol. of plates, 1841. New edition (Birch), 3 vols., 1878.
 WILKINSON, *Mat. Hiero.* WILKINSON (J. GARDNER), Materia Hieroglyphica. 2 vols., 1828-30.
 WRESZINSKI, *Atlas* WRESZINSKI (WALTER), Atlas zur altägyptischen Kulturgeschichte. 1st part, 1915-23; 2nd part, 1924, &c.

LIST OF COLLECTIONS OF MANUSCRIPTS¹

- Bonomi MSS. In the possession of the Baroness de Cosson in Florence. Joseph Bonomi was in Egypt from 1824 to 1833 and from 1842 to 1844.
- Bonomi MSS. (A). Certain drawings in the possession of Mr. A. F. C. de Cosson.
- Burton MSS. In the British Museum, Add. MSS. 25613-25675, see Hilmy, *Bibliography of Egypt and the Sudan*, 108-11. James Burton travelled in Egypt and Nubia between 1820 and 1839.
- Devéria squeezes. In the Louvre. Devéria first visited Egypt in 1858. Died in 1871 as Conservateur of the Egyptian Department in the Louvre.
- Hay MSS. In the British Museum, Add. MSS. 29812-29860, 31054, see Hilmy, *op. cit.* pp. 292-4. Robert Hay of Linplum and his artists made the drawings, &c., in Egypt and Nubia between 1824 and 1838.
- Hoskins MSS. In the possession of Dr. Alan Gardiner. G. A. Hoskins travelled in Egypt in 1832-3 and 1860-1.
- Lepsius MSS. Diary. Manuscript Tagebuch of Richard Lepsius from Oct. 30 to Dec. 7, 1844, containing chiefly texts from tombs and temples at Thebes. Discovered recently and therefore not utilized for the *L. D. Text*. Now in the possession of the Berlin Museum.
- Nestor l'Hôte MSS. In the Bibliothèque Nationale in Paris, Nouvelles Acquisitions françaises, 20394-20415. Nestor l'Hôte was in Egypt in 1838-9.
- Prisse MSS. In the Bibliothèque Nationale in Paris, Nouvelles Acquisitions françaises, 20430-3. Prisse d'Avennes was in Egypt from 1840 to 1846(?).
- Prudhoe MSS. In the possession of the Duke of Northumberland at Alnwick Castle. Drawings, chiefly of Upper Nubia, by Major Felix, in 1828 and onwards.
- Rosellini MSS. In the Biblioteca Universitaria, Pisa. Rosellini was in Egypt in 1828-9.
- Saint-Ferriol MSS. Diary. Manuscript Diary of the Count Louis de Saint-Ferriol, who travelled in Egypt between 1839 and 1843. His papers are in the possession of the heirs of his son, the late Count Gabriel de Saint-Ferriol.
- Wild MSS. In the possession of the Misses Wild, London. James William Wild, architect, was attached to the Lepsius Expedition in 1842, and later Curator of the Soane Museum.
- Wilkinson MSS. Bequeathed to the late Sir John Harpur Crewe to be kept as heirlooms at Calke Abbey, Derbyshire. The Egyptological portions are now deposited on loan in the Bodleian Library at Oxford, by kind permission of the present owner, Mrs. Godfrey Mosley. Sir J. Gardner Wilkinson travelled in Egypt and Nubia between 1821 and 1831, 1841-2, 1848-9 and 1855.

¹ References to these manuscripts in the letter-press are distinguished by an asterisk (*).

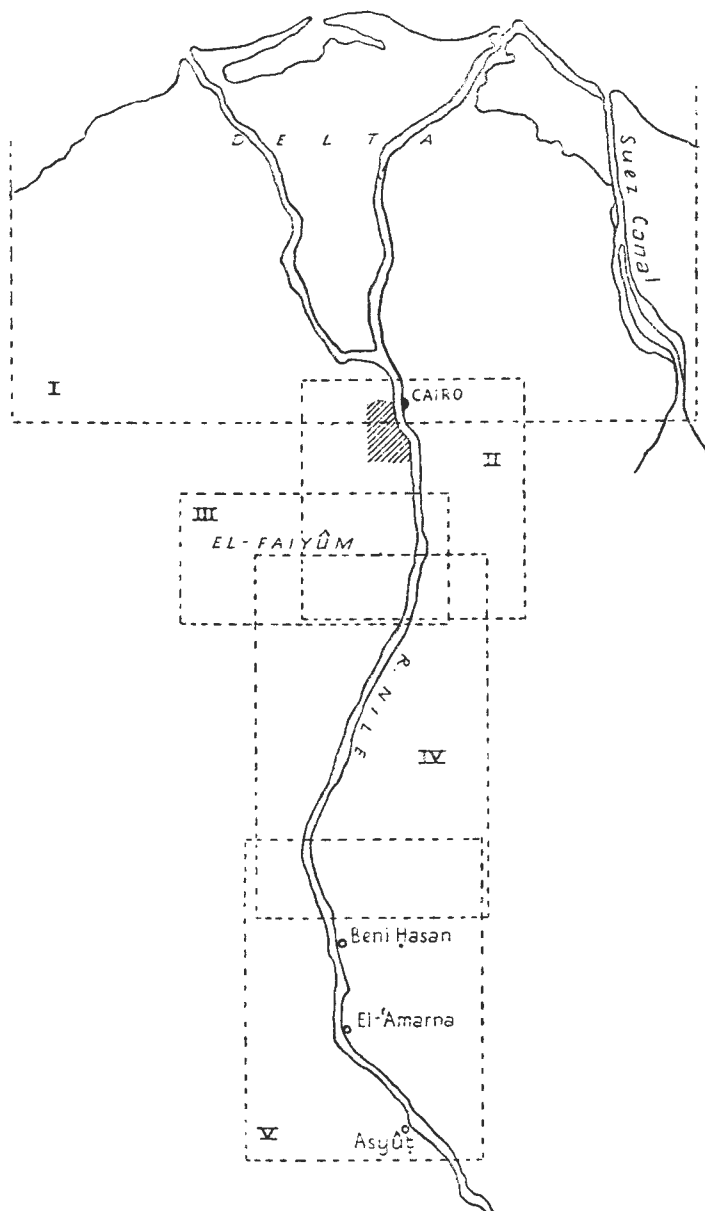

KEY-MAP.

The Roman numbers refer to maps on pp. 271-5. The shaded part represents the Memphite Necropolis, dealt with in *Bibl.* iii.

I. NORTHERN DELTA

NORTH COAST

EL-'ARÍSH TO ALEXANDRIA

EL-'ARÍSH

Black granite naos, Ptolemaic, in Museum at Isma'ilia, GRIFFITH, *Tell el Yahúdíyeh*, pls. xxiii-xxvi, cf. pp. 70-4; see ROEDER, *Urkunden zur Religion des alten Ägypten*, 150-6.

TELL FARAMÂ (PELUSIUM)

Plan of site, CLÉDAT, *Le Temple de Zeus Cassios à Péluse* in *Ann. Serv.* xiii, p. 80, fig. 1. View, id. *Notes sur l'isthme de Suez* in *Bull. Inst. Fr. Arch. Or.* xxii, pl. iii [upper].

Weight of Nektanebos I (Nekht-neb-f), found at west end of ruins; texts, id. *Notes sur l'isthme de Suez* in *Rec. de Trav.* xxxvii, p. 34, figs. 2-4.

TELL EL-MAKHZAN, east of Tell Faramâ.

Fragment of red sandstone naos (?), probably temp. Ramesses II, id. ib. p. 33, fig. 1.

DAMIETTA

Top of black granite naos with remains of list of deccans on one side and back (possibly from ROSETTA, see *Descr. de l'Égypte, Ant. Texte*, x, p. 544, note), in Louvre D. 37, *Descr. de l'Égypte, Ant.* v, pl. 48, cf. *Texte*, x, pp. 543-4; side and back, PIERRET, *Inscr. du Louvre*, ii. 73; part of texts, YOUNG, *Hieroglyphics*, pl. 37 [upper]; BRUGSCH, *Thes.* 182, 184, cf. 179-83; see BOREUX, *Guide-Catalogue Sommaire* (1932), i, pp. 120-1.

TELL EL-ASH'ÂR, north-east of Baltim.

Ptolemaic doorway, in Cairo Mus., and two inscribed blocks; texts, KAMAL, *Borollos* in *Ann. Serv.* ix. 145-7; texts of doorway, DARESSY, *La porte de Beltim* in *Ann. Serv.* xvii. 277-8.

ROSETTA

Black basalt stela, the 'Rosetta Stone', with trilingual inscription of year 9 of Ptolemy V Epiphanes, found in Fort St. Julien, in Brit. Mus. 24, *Descr. de l'Égypte, Ant.* v, pls. 52-4, cf. *Texte*, x, pp. 547-50; YOUNG, op. cit. pls. 16-30; ARUNDALE and BONOMI, *Gallery of Antiquities*, pl. 49; LEPSIUS, *Auswahl*, xviii-xix; BUDGE, *The Rosetta Stone*, passim with one plate; *Guide, Sculpture* (1909), pl. xxxv, cf. pp. 258-9 [960]; *Guide to the Egyptian Collections* (1909), pp. 42-3; (1930), pp. 42-3; hieroglyphic and Greek texts, SETHE, *Urk.* ii. 169-98 (36) R; hieroglyphic text, SHARPE, *Eg. Inscr.* 1 Ser. 49-50.

Intercolumnar block, inscribed on both sides, Psammetikhos I before bull-headed gods, said to be from Temple of Atum at Rosetta, in Brit. Mus. 20, YOUNG, op. cit. pls. 7 [i, iii], 8 [vi], 10 [ix]; one side, ARUNDALE and BONOMI, op. cit. pl. 45, fig. 167, cf. p. 109; see YORKE and LEAKE, *Remarks on some Egyptian Monuments in England*, pl. x [28]; head of King, *Guide to the Egyptian Collections* (1930), p. 385, fig. 211; see *Guide, Sculpture* (1909), p. 222 [800].

Intercolumnar block from same temple, Nektanebos I (Nekht-neb-f) in offering-scenes (on both sides), in Brit. Mus. 998, YOUNG, *op. cit.* pls. 7 [ii, iv], 8 [v, vii]; ARUNDALE and BONOMI, *op. cit.* pl. 45, fig. 165, cf. pp. 110-11; see YORKE and LEAKE, *op. cit.* pl. x [27]; *Guide, Sculpture* (1909), p. 250 [927].

Shaft of basalt column of Psammetikhos I, in Brit. Mus. 964, see *id. ib.* p. 222 [802]. (For granite naos in Louvre, see *supra* p. 1, Damietta.)

IDKU, south of Rosetta.

Part of granite statue of Hor , Commander of troops, Saite, built into minaret of mosque; text on back, KAMAL, *Fragments de monuments provenant du Delta in Ann. Serv.* v. 199, § ii.

ABÛ QÎR (CANOPUS)

Plan of site, BRECCIA, *Le Rovine e i Monumenti di Canopo in Mon. de l'Égypte Gréco-Romaine*, i, Pt. i, pl. ii, cf. pp. 35-50.

TEMPLE OF ISIS (?). Ptolemaic (?). North-east of Fort Taufiq.

See DANINOS-PACHA, *Note sur les fouilles d'Aboukir in Rec. de Trav.* xii. 209-13; BRECCIA, *op. cit.* p. 42.

Court.

Red granite colossus of Ramesses II with standard, and small figure of Queen Hentmare'  at side (usurped), in Alexandria Mus., *id. ib.* pl. xxiv, cf. p. 58 [2]; *id. Alexandria ad Aegyptum* (1922), p. 354, fig. 253 [middle], cf. p. 143 [1]; texts, and title of King on belt, DARESSY, *Inscriptions hiéroglyphiques du Musée d'Alexandrie in Ann. Serv.* v. 114-15 [iii]; text of Queen, DANINOS-PACHA, *op. cit.* 211, 212.

Red granite colossal double-statue (headless) of Ramesses II and Queen, in Alexandria Mus., BRECCIA, *Alexandrea ad Aegyptum* (1922), p. 354, fig. 253 [left], cf. pp. 143 [18], 283.

Quartzite sphinx of Amenemhêt IV, and limestone sphinx usurped by Ramesses II, (both headless), probably from entrance to Court, now in Alexandria Mus.; texts, DARESSY, *op. cit.* 116 [v, vi]; sphinx of Amenemhêt IV, EVERS, *Staat aus dem Stein*, i, pls. 135, 136; cartouche, DANINOS-PACHA, *op. cit.* 213; see BRECCIA, *Alexandrea ad Aegyptum* (1922), p. 143 [3, 5].

Head and bust of Ramesses II, in Alexandria Mus., and two royal heads found near sphinxes, see DANINOS-PACHA, *op. cit.* 213; one head and description, BRECCIA, *Le Rovine* [&c.], pl. xxvi [1], cf. pp. 58-9 [3, 7, 8, 9]; cf. *id. Alexandria ad Aegyptum* (1922), p. 143 [4, 18].

MISCELLANEOUS.

Red granite statue of Ramesses II with standard, usurped by Merneptah, in Cairo Mus. 574, BORCHARDT, *Statuen und Statuetten* (Cat. Caire), ii, pl. 98, pp. 122-3; JÉQUIER, *L'Architecture*, ii, pl. 42 [left]; BRECCIA, *Le Rovine* [&c.], pl. xxv [1], cf. p. 57 [1].

Sphinx (headless), found near sea, in Alexandria Mus., see *id. ib.* p. 59.

Basalt torso holding stela with Horus attacking with spear, found south-west of Temple near sea, *id. ib.* pl. xxv [3], cf. pp. 58 [6], 43.

ALEXANDRIA

Map, *Descr. de l'Égypte, Ant.* v, pl. 31, *État moderne*, ii, pl. 84; BRECCIA, *Alexandrea ad Aegyptum* (1922), plan at end.

WEST HARBOUR.

Granite statues of Ramesses II, probably originally from Heliopolis, on quay north

of Custom House; one, L. D. iii. 142 a-c, cf. *Text*, i, p. 1 [middle lower]; two heads, L. D. *Ergänz.* i [a, b].

Colossal statue (headless), King and goddess, near last, L. D. *Text*, i, p. 1 [bottom right].

SERAPEUM.

Pompey's Pillar.

Views, LUCAS, *Voyage* (1724), ii, plate opposite p. 23; PERRY, *A View of the Levant* (1743), pl. 23 [right]; *Descr. de l'Égypte, Ant.* v, pl. 34 [1, cf. 2-5], cf. *Texte*, x, pp. 513-14; CASSAS, *Voyage Pittoresque* (1799), iii, pl. 58; DENON, *Voyage* (1802), 9 [left]; HAMILTON, *Aegyptiaca*, xviii; TRÉMAUX, *Parallèles des Édifices Anciens* [&c.], pl. 50 [middle]; GORRINGE, *Egyptian Obelisks*, pl. xli [right]; HAY*, 29812, 11, 12; HOSKINS MSS.* i. 157.

Three blocks supporting Pillar, see WILKINSON, *Modern Egypt and Thebes*, i, p. 151; id. MSS.* iv. 14, 24 [bottom]. (a) Block of Sesostris II or III, in Brit. Mus. 145, NORDEN, *Travels in Egypt and Nubia* (1757), pls. xi, xii; *Descr. de l'Égypte, Ant.* v, pl. 34 [6-9], cf. *Texte*, x, pp. 514-15; CLARKE, *Travels* (1814), Pt. 2, Sect. 2, plate opposite p. 260 [lower]; *Hiero. Texts* [&c.], Pt. iv, pl. 8 [top]; see L. D. *Text*, i, pp. 1-2 (attributed to Psammetikhos I); *Guide*, Sculpture (1909), p. 86 [298]. (b) Block of Sethos I, CASSAS, op. cit. iii, pl. 58 [B]; part, CLARKE, op. cit. plate opposite p. 260 [upper]. (c) Block of Psammetikhos I; cartouche, L. D. *Text*, i, p. 1 [bottom left].

Found near Pompey's Pillar.

Upper part of black granite statue of Sesostris I (?), usurped by Merneptah, (head found in Arab quarter), in Cairo Mus. 384, BORCHARDT, op. cit. ii, pl. 60, pp. 3-4; EVERS, op. cit. i, pl. 36; see MASPERO, *Guide* (1914), p. 149 [532].

Black granite statue of Ramesses II, in Cairo Mus. 620, BORCHARDT, op. cit. ii, pl. 112, pp. 165-6.

Red granite seated statue (headless) of Ramesses II, in Alexandria Mus., see BRECCIA, *Alexandrea ad Aegyptum* (1922), p. 152 [27].

Block of Ramesses II, found at base of Pillar, in Brit. Mus. 104, see *Guide*, Sculpture (1909), p. 160 [578].

Black granite statue of Sekhmet, with substituted text of Ramesses II (probably originally from Temple of Mut at Karnak), in Cairo Mus. 39067, DARESSY, *Statues de Divinités* (Cat. Caire), pl. li, p. 266.

Offering-table of Ramesses IX, originally from Heliopolis, in Cairo Mus. 23093, KAMAL, *Tables d'Offrandes* (Cat. Caire), 79-80.

Fragment of kneeling statue of Ramesses IX, originally from Heliopolis; text, DARESSY, *Inscriptions hiéroglyphiques du Musée d'Alexandrie* in *Ann. Serv.* v. 117 [vii].

Lower part of kneeling statue of Psammetikhos I holding naos, originally from Heliopolis; texts, BRECCIA, *Les fouilles dans le Sérapéum d'Alexandrie en 1905-1906* in *Ann. Serv.* viii. 64.

Two Ptolemaic statues of Pshenptah , Priest, in Alexandria Mus.; texts, id. ib. p. 65; see id. *Alexandrea ad Aegyptum* (1922), p. 144.

FOUND NEAR EAST HARBOUR.

Fragment of statue, apparently of a governor of Heracleopolis Magna, Late Period, in Alexandria Mus.; text on back, DARESSY, op. cit. in *Ann. Serv.* v. 127 [xli].

MOSQUE OF ST. ATHANASIUS.

Sarcophagus of Nektanebos II (Nekht-ḥar-ḥebi), formerly attributed to Alexander the

Great, in Brit. Mus. 10 (cf. *Guide*, Sculpture, pp. 248-9 [923]), *Descr. de l'Égypte, Ant.* v, pls. 40, 41, cf. *Texte*, x, pp. 525-9; ALEXANDER, *Egyptian Monuments* (1805-7), 1st, 2nd, 7th, 9th, 13th, 14th, 17th, 18th, 19th plates; exterior (reversed), omitting texts, SEYFFARTH, *Systema Astronomiae Aegyptiacae quadripartitum in Beitrage zur Kenntniss der Literatur, Kunst, Mythologie und Geschichte des Alten Aegypten* (1833), pls. v a, v b, p. 243 et seq. (called sarcophagus of Sethos I); view of end and right side, BUDGE, *Egyptian Sculptures in the British Museum*, pl. xliv; *Guide to the Egyptian Collections* (1930), p. 396, fig. 219; left side, *Guide*, Sculpture (1909), pls. xxxii-xxxiii after p. 248; part of sides, *Guide to the Egyptian Collections* (1909), pl. ii opposite p. 66, pl. xlvii opposite p. 265; (1930), p. 87, fig. 33, p. 215, fig. 115; texts and figures of right side, SHARPE, *Eg. Inscr.* 1 Ser. 28-32; rough sketch, YORKE and LEAKE, *Remarks on some Egyptian Monuments in England*, pl. vi.

ARSINOEION.

Gold plaque with hieroglyphic and Greek inscription, from foundation deposit, Ptolemy IV Philopator and Arsinoë III; texts, BRUGSCH, *Thes.* 917 [bottom]; MASPERO, *Sur une plaque d'or portant la dédicace d'un temple* in *Rec. de Trav.* vii. 141.



KÔM EL-DAMÂS.

Upper part of black granite statue of Ḥor , son of Ḥor, Roman, in Cairo Mus. 697, MASPERO, *L'Archéologie égyptienne*, 2^e éd. (1887), p. 230, fig. 203; id. *Guide* (1914), p. 217, fig. 66, cf. pp. 215-16 [972]; BORCHARDT, *Statuen und Statuetten* (Cat. Caire), iii, pl. 128, pp. 39-40; texts, DARESSY, *Statues de basse époque du Musée de Gizéh* in *Rec. de Trav.* xv. 157-8 [6].

CAESAREUM.

Pair of obelisks, 'Cleopatra's Needles', Tuthmosis III, with additional inscriptions of Ramesses II and Siamûn, originally from Heliopolis, erected in front of the Caesareum facing the sea by Augustus in 22 B.C., the eastern or 'standing' obelisk, removed to New York in 1879-80, the western obelisk overthrown after 1201 probably by the great earthquake of 1303, removed to London in 1877-8, now on the Thames Embankment. Both obelisks *in situ*, London one lying on ground, NORDEN, *Travels in Egypt and Nubia* (1757), pl. vii; CASSAS, *Voyage Pittoresque* (1799), iii, pl. 52; AINSLIE, *Views in Egypt* [&c.] (1805), plate opposite p. 28. Eastern obelisk, in New York, GORRINGE, *Egyptian Obelisks* (1885), pls. i, iv, v, xx, xxix, xxx, xxxi; HAY*, 29812, 6-10; BURTON, *Excerpta Hiero.* lii; WILKINSON MSS.* iv. 10-13 [left]; four faces with pyramidion, NORDEN, op. cit. pls. vii-ix; CHAMPOLLION, *Mon.* ccccliv; two faces, *Descr. de l'Égypte, Ant.* v, pl. 33 [1, 2], cf. 32; south face, KIRCHER, *Oedipi Aegyptiaci* (1654), iii. 340-1; one face, TRÉMAUX, *Parallèles des Édifices Anciens* [&c.], pl. 50 [left]; STEINDORFF, *Die Blütezeit des Pharaonenreichs* (1900), p. 34, Abb. 31; texts of Tuthmosis III on all faces, SETHE, *Urk.* iv. 592-4 (189) B; see MOLDENKE, *The New York Obelisk*, passim. Western obelisk, in London, GORRINGE, op. cit. pl. xxxvii; BUDGE, *Cleopatra's Needles and other Egyptian Obelisks*, frontispiece; sketch, BURTON MSS.* 25634, 8; four faces with pyramidion, id. *Excerpta Hiero.* li; CHAMPOLLION, *Mon.* cccclv-vi; WILKINSON MSS.* iv. 8-9, 16-19; two faces with pyramidion, *Descr. de l'Égypte, Ant.* v, pl. 33 [3-6]; one face with pyramidion, MOSKONAS, *Deux mots sur les Obélisques d'Égypte*, table i; texts of Tuthmosis III, SETHE, *Urk.* iv. 590-2 (189) A; 1, 2, and 3 of Sethe, MOSKONAS, op. cit. table ii; some of the Ramesside texts (= face 2 of BURTON), MOSKONAS, op. cit. table iii. Small cartouches of Siamûn low down on edge of both shafts, L. D. *Text*, i, p. 2. (A fragment of London obelisk is in Brit. Mus. 943, see *Guide*, Sculpture, 1909, p. 106 [364].)

NICOPOLIS.

Sandstone block of Ra'mosi Ⓞ , son of Psherenmeht , Late Period; text, BRUGSCH, *Recueil*, x [4].

MISCELLANEOUS. (From Alexandria, but exact provenance unknown.)

Black granite statue of Tuthmosis III; text on shoulder, id. ib. x [3].

Three granite columns, in Vienna Mus.; cartouches of Tuthmosis IV, Merneptah, and Sethos II, BERGMANN, *Inchriftliche Denkmäler* [&c.] in *Rec. de Trav.* vii. 178; see *L. D. Text*, i, p. 217.

Sandstone jamb of Sethos I, originally from Heliopolis, in Alexandria Mus.; texts, DARESSY, *Inscriptions hiéroglyphiques du Musée d'Alexandrie* in *Ann. Serv.* v. 120-1 [xxiii]; see BRECCIA, *Alexandria ad Aegyptum* (1922), p. 152 [21].

Fragment of naos of Ramesses II, from environs of Alexandria, in Brit. Mus., ALEXANDER, *Egyptian Monuments* (1805-7), 4th plate; YORKE and LEAKE, *Remarks on some Egyptian Monuments in England*, pl. i [2].

Black granite crouching statue of man holding naos containing ape, New Kingdom, *Descr. de l'Égypte, Ant.* v, pl. 60 [1-4].

Monolithic naos, dedicated by Amenhotp (?), New Kingdom, possibly from here, id. ib. pl. 47 [6-8].

Monolithic naos of Osiris, dedicated by Amasis, found in the sea near Alexandria, in Louvre D. 29, SEYFFARTH, op. cit. in *Beitraege zur Kenntniss der Literatur, Kunst, Mythologie und Geschichte des Alten Aegypten* (1833), pl. vii, p. 270 et seq.; BOREUX, *Guide-Catalogue Sommaire* (1932), i, pl. xiii, cf. p. 129; scenes on front and sides, LANZONE, *Dizionario di mitologia egizia*, pls. xiv-xvii; texts, PIERRET, *Inscr. du Louvre*, i. 74-9; see DE ROUGÉ, *Notice des Monuments*, pp. 190-3.

Lower part of statue of Wehebre' Ⓞ , Overseer of the frontier, Director of temples, holding naos, Dyn. XXVI, formerly in building of Service Sanitaire, now in Cairo Mus. 677; texts, including that of another fragment (now lost, and perhaps from a different statue), BRUGSCH, *Thes.* 1067-8 [upper]; GAUTHIER, *À travers la Basse-Égypte* in *Ann. Serv.* xxii. 91-2; text of Cairo fragment, BORCHARDT, *Statuen und Statuetten* (Cat. Caire), iii, pp. 22-3. (See infra p. 47.)

Fragment of statue of Achoris, probably originally from Heliopolis, seen by Lepsius in court of Greek Consulate; text, *L. D.* iii. 284 e, cf. *Text*, i, p. 1 [top]; see GAUTHIER, *Le Livre des Rois*, iv. 167 [xix].

Block, women preparing lilies, Dyn. XXVI, in Turin Mus. 179, ROSELLINI, *Mon. Civ.* lxxvi [1], cf. *Text*, ii. 367-8 (copied in Alexandria); CAILLIAUD, *Arts et Métiers*, pl. 15 A [7-9]; see LANZONE, *Regio Museo di Torino*, p. 186 [1673]; ORCURTI, *Catalogo Illustrato* [&c.], p. 27 [N 23]; BISSING, *Graeco-aegyptische Reliefs in Museum Scheurleer* in *Bull. v. Vereeniging tot Bevordering der Kennis v. Antieke Beschaving* (1929), p. 11. (Cf. infra p. 64, footnote.)

Drums of columns of Nektanebos I (Nekht-neb-f) and a Ptolemy, seen by Lepsius on either side of gateway in French Consulate; texts, *L. D. Text*, i, p. 1 [middle upper].

Intercolumnar block inscribed on both sides, Nektanebos I offering, in Brit. Mus. 22, GARDNER in ROSS, *Art of Egypt* [&c.], p. 232; head of King, *Guide to the Egyptian Collections* (1930), p. 394, fig. 217; see *Guide, Sculpture* (1909), p. 250 [926].

Stela of Horus on the crocodiles, Nektanebos II (Nekht-har-ḥebi), known as the 'Metternich stela', found in a Franciscan monastery, now at Schloss Metternich, Königswarth, Bohemia, GOLÉNISCHEFF, *Die Metternichstela*, passim, with nine plates; ll. 48-71, 168-70, 177-90, 202-12, BRUGSCH, *Eine Geographische Studie* in *A.Z.* xvii. 1-9; see id. *Die Metternich-Stele* in *Zeitschrift d. Deutsch. Morgenland. Gesell.* x (1856), pp. 677-90.

Lower part of black granite statue-group, Ptolemy II Philadelphus, his wife Arsinoë II, and his sister Philotera, in Alexandria Mus.; texts, DARESSY, op. cit. in *Ann. Serv.* v. 126 [xxxviii]; see GAUTHIER, *Le Livre des Rois*, iv, p. 237 [lxiii] with note 3.

Fragment of statue of Ptolemaea , Priestess, Ptolemaic, in Brit. Mus. 985, see *Guide, Sculpture* (1909), p. 263 [975].

Stela of Horus on the crocodiles inscribed on both sides, Ptolemaic, in Cairo Mus. 9401, MARIETTE, *Mon. Div.* pl. 15; DARESSY, *Textes et Dessins Magiques* (Cat. Caire), pl. i, pp. 1-3; front, MASPERO, *Guide* (1914), p. 474 [4750], fig. 115.

Block with Tefnut as lioness, found in a house, SHARPE, *Eg. Inscr.* 1 Ser. 120.

Fragment of intercolumnar screen or sarcophagus, man with offerings, *Descr. de l'Égypte, Ant.* v, pl. 47 [5], cf. *Texte*, x, p. 542.

See also Graeco-Egyptian Collection of Ernst von Sieglin, SCHREIBER-SIEGLIN, *Ausgrabungen in Alexandria*, six vols. passim, and addenda, infra p. 270.

NEAR LAKE MARYÛT (MAREOTIS)

Colossal black basalt kneeling statue of Weḥebrē' , Overseer of the frontier, Commander of troops over the North and South, Director of temples, holding naos of Osiris, Dyn. XXVI, in Brit. Mus. 111, SHARPE, *Egyptian Antiquities in the British Museum* (1862), p. 96, fig. 52; BUDGE, *Egyptian Sculptures in the British Museum*, pl. xlvii; *Guide to the Egyptian Collections* (1909), pl. xlv opposite p. 261; (1930), p. 390, fig. 215; texts, *Hiero. Inscr. Syro-Egyptian Soc.* pl. 2; PIEHL, *Inscr. Hiéro.* 3 Sér. xlii-xliii v, cf. p. 31; GAUTHIER, op. cit. in *Ann. Serv.* xxii. 86-8; see *Guide, Sculpture* (1909), p. 227 [818]. (See infra p. 47.)

Two stelae, associated together in collection of Daninos Pasha, probably from here, now in Cairo Museum. (a) Stela, year 19 of Sesonchis IV, describing gift of land to Ḥathor of Terenuthis by a caravan-leader and a chief of Libya; text, MASPERO, *Sur deux stèles récemment découvertes* in *Rec. de Trav.* xv. 84-5. (b) Stela, year 1 of Amasis, gift of land to Osiris; text, id. ib. 86.



KURÛM EL-TUWÂL, near El-ʿĀmiriyya.

Inscribed blocks built into modern buildings; texts, EILMANN, LANGSDORFF, and STIER, *Bericht über die Voruntersuchungen auf dem Kûrum el-tuwâl bei Amrije* in *Mitteil. d. Deutsch. Inst. Cairo*, i, p. 107 note 2.

EAST PART

A. EL-QANṬARA TO ṢAFT EL-ḤINNA

EL-QANṬARA

TELL ABÛ SEIFA. (Probably site of Mesen  and Tharu ), capital of the XIVth nome of Lower Egypt.)

Fragment of quartzite pedestal with vertical sides crowned by cornice, dedicated by Ramesses II to Horus of Mesen, GRIFFITH in PETRIE, *Nebesheh* (in *Tanis*, ii), pl. li [upper right], cf. pp. 104-5.

Oblong base, &c., of quartzite monument with tapering sides, with dedication-text of Sethos I and Ramesses II to Horus of Mesen commemorating Ramesses I, part at one time at Port Sa'ïd and part at El-Qanṭara, re-united in 1923 in Public Garden at Isma'ilia; portions, GAUTHIER, *À travers la Basse-Égypte* in *Ann. Serv.* xxiii, pls. i, ii, pp. 178-82;

texts, CLÉDAT, *Notes sur l'isthme de Suez* in *Rec. de Trav.* xxxi. 118-20; front (El-Qantara portion) and left side (Port Sa'ïd portion), PRISSE, *Mon.* xix [1, 2, 3]; back, and three lines above, GRIFFITH in PETRIE, op. cit. pl. li [upper left], cf. pp. 97, 103-4; correction of dedication-text, GRIFFITH, *Tell el Yahûdiyeh*, p. 70.

CEMETERY.

See id. in PETRIE, op. cit. p. 99; CLÉDAT, *Nécropole de Qantarah (fouilles de mai 1914)* in *Rec. de Trav.* xxxviii. 21-31.

Limestone sarcophagus of Pedamenôpet (?) $\square \Delta \left[\begin{array}{c} \text{⠏⠗⠏⠗} \\ \text{⠏⠗⠗⠗} \end{array} \right] \Delta$ (?), Priest, in Cairo Mus.; texts, DARESSY, *Sarcophages d'El Qantarah* in *Bull. Inst. Fr. Arch. Or.* xi. 29-34 [i, ii]; parts, CHABÂN, *Fouilles exécutées près d'El-Kantara* in *Ann. Serv.* xii. 71; list of twelve Tuëris divinities in interior, DARESSY, *Thouëris et Meskhenit* in *Rec. de Trav.* xxxiv. 190-1.

Sarcophagi of Hepmen $\left[\begin{array}{c} \text{⠏⠗⠗} \\ \text{⠏⠗⠗} \end{array} \right]$ and his son Hepmen $\left[\begin{array}{c} \text{⠏⠗⠗} \\ \text{⠏⠗⠗} \end{array} \right]$; texts, CHABÂN, op. cit. 72-3; DARESSY, op. cit. in *Bull. Inst. Fr. Arch. Or.* xi. 34 [iii, iv].

TELL DAFANA (DAPHNAE) $\Rightarrow \left[\begin{array}{c} \text{⠏⠗⠗} \\ \text{⠏⠗⠗} \end{array} \right] \otimes$

See PETRIE, *Nebesheh* (in *Tanis*, ii), pls. xxii-xlvi, pp. 47-96, with plans and objects found. Plan of site, id. ib. pl. xliii.

CENTRAL FORT.

Plan, id. ib. pl. xlv.

Foundation deposits of Psammetikhos I under corners, in Brit. Mus. 23556, and one plaque, in Berlin Mus. 10080, id. ib. pls. xxii, xxiii, pp. 54-5; see *Guide to the Fourth, Fifth and Sixth Egyptian Rooms* (1922), p. 208 [149]; *Ausführ. Verzeichnis* (1899), p. 253.

ENCLOSURE WALL ON NORTH.

Exterior.

Lower part of sandstone stela from temple of Min, probably Psammetikhos I, PETRIE, op. cit. pl. xlii [lower], cf. pp. 48, 59, 107-8.

CAMP. East of Enclosure.

Plan, id. ib. pl. xlv, cf. pp. 59-60.

Fayence plaque of Apries, from foundation deposit, found in a room, now in Brit. Mus. 2807, id. ib. pl. xl [7], cf. p. 75; HALL, *Catalogue of Egyptian Scarabs, &c.*, i, p. 295.

MISCELLANEOUS.

Upper part of statue of Asiatic prisoner, New Kingdom, in Cairo Mus. 749, BORCHARDT, *Statuen und Statuetten* (Cat. Caire), iii, pl. 139, cf. p. 73.

EL-MUNĀGĀT EL-KUBRA

Sandstone block of Nektanebos I (Nekht-neb-f) with Buto of Amt, GRIFFITH in PETRIE, op. cit. pl. xlii [upper left], cf. p. 46.

NABÊSHA (TELL FAR'ÛN) $\left[\begin{array}{c} \text{⠏⠗⠗} \\ \text{⠏⠗⠗} \end{array} \right] \otimes$

Capital of the XIXth nome of Lower Egypt.

See PETRIE, *Nebesheh* (in *Tanis*, ii), pp. 1-37, pls. i-xiii, xix [lower], (with chapter by GRIFFITH). General plan, id. ib. pl. xvii [top right]; KAMAL, *Tel Far'on (Bouto)* in *Ann. Serv.* iii. 8.

TEMPLE OF GODDESS BUTO.

Plan, PETRIE, *op. cit.* pl. xiv.

Approach to Pylon.

Red granite column of Merneptah; texts, *id. ib.* pl. x [9 a-c], cf. pp. 9, 31.

Pylon.

Blocks of Ramesses III in pavement; texts, *id. ib.* pl. x [8, 10], cf. p. 31.

Two black granite sphinxes, Middle Kingdom, with names of Sethos II on chest, Setnakht on shoulder, Ramesses III on front of wig, and on bases text of Bay , Chancellor, temp. Siptah, from inner side of Pylon; texts of Bay and cartouches of Setnakht, *id. ib.* pl. x [6 a-c], cf. pp. 10-11, 29.

GREAT TEMPLE.

Crouching statue of Merneptah , Royal scribe and groom, with figures of Buto and the Syrian Sêth, temp. Ramesses II, lying on northern part of substructure at south-east corner; texts, *id. ib.* pl. xi [16], cf. pp. 12, 30; see GRIFFITH, *The God Set of Ramessu II, and an Egypto-Syrian Deity* in *P.S.B.A.* xvi. 87.

SMALL TEMPLE OF AMASIS.

Foundation-deposit of Amasis, in Brit. Mus. 23503, PETRIE, *op. cit.* pl. v [1, 5, 6, 10], cf. p. 14; see *Guide to the Fourth, Fifth and Sixth Egyptian Rooms* (1922), p. 208 [151].

Statue-thrones of Sesostris III, probably from either side of door; one, in Brit. Mus. 1069, PETRIE, *op. cit.* pl. ix [2 a, b], cf. p. 13; *Hiero. Texts* [&c.], Pt. iv, pl. 9; see *Guide, Sculpture* (1909), p. 48 [165].

Back of monolithic granite naos of goddess Buto, dedicated by Amasis, found *in situ* at north end of Temple, PETRIE, *op. cit.* pls. iv, ix [3], cf. pp. 13, 34.

Part of black granite statue of Buto, dedicated by Ramesses II, probably from naos; text, *id. ib.* pl. x [7], cf. pp. 13, 30.

Black granite triple-group of Minmosi , Royal scribe, Overseer of the cattle of Amün, and his parents, Ay and Rennüfer, probably Dyn. XIX, found beside last, now in Oxford, Ashmolean Mus.; text on altars in front of figures, *id. ib.* pl. x [5], cf. pp. 13, 30.

Blocks of granite stela dedicated to Min by Amasis, between vestibule and naos, *id. ib.* pl. ix [4], cf. pp. 34, 35.



Offering-table of Amenemhêt II with text of [Bay¹ , Chancellor, Overseer of sealers, temp. Siptah, outside rear wall, *id. ib.* pl. ix [1], cf. pp. 15-16, 29.

Various fragments of statuettes; texts, *id. ib.* pl. x [11-13], cf. p. 36.

Cemetery.

See *id. ib.* pp. 17-25. Plans of site and tombs, *id. ib.* pls. xv, xvi.

TOMB 77. Saite.

Three large sarcophagi. (a) Basalt sarcophagus of Psammethek , Priest, in Brit. Mus. 1047; text, *id. ib.* pl. xii [18], cf. pp. 22, 35-6; see *Guide, Sculpture* (1909), pp. 230-1 [829]. (b) and (c) Limestone sarcophagi of Psammethek-menkh-ib , Priest, and of another Psammethek; texts, PETRIE, *op. cit.* pl. xii [19-20], cf. pp. 22, 35-6.

TOMB 42.

Limestone sarcophagus of Pedeamün , Commander of troops; text, *id. ib.* pl. xii [21], cf. p. 36.

TOMB OF RĒ'ARDAIS , Late Period.

Lid of sarcophagus; texts, KAMAL, *Tel Far'on (Bouto)* in *Ann. Serv.* iii. 11-12.

¹ See inscription of same man on sphinxes, *supra*.

Town. Ptolemaic.

See PETRIE, *op. cit.* pp. 25-7, pl. vii. Plan, id. ib. pl. xvii.

Miscellaneous.

(From Nabêsha, but exact provenance unknown.)

Head of red granite statue of King with inscribed support at back, Dyn. XIX, in Cairo Mus. 640, BORCHARDT, *Statuen und Statuetten* (Cat. Caire), ii, pl. 118, p. 187.

Black granite crouching statue of Amenhotp, Scribe of the Hermonthite nome, probably Dyn. XIX; texts, PETRIE, *op. cit.* pl. x [15], cf. p. 31.

Basalt statue of Harkhebi , Astrologer, Snake-charmer, Dyn. XXX, in Cairo Mus.; texts, KAMAL, *Rapport sur quelques localités de la Basse-Égypte* in *Ann. Serv.* vii. 239-40; DARESSY, *La Statue d'un astronome* in *Ann. Serv.* xvi. 2.

GUMAÏYIMA, three miles north-west of Nabêsha.

TEMENOS AND TEMPLE. Ptolemaic.

See GRIFFITH in PETRIE, *Nebeshek* (in *Tanis*, ii), pp. 37-45, pls. xviii-xx. Plan, id. ib. pl. xxi.

NEIGHBOURHOOD OF FAQUS

KHATÂ'NA, north-east of El-Didâmûn.

REMAINS OF TEMPLE, near Khatâ'na.

Fragment of double-statue of man and woman with offering-text to King S'ankhkarê' Mentuhotp V, GRIFFITH in PETRIE, *Nebeshek* (in *Tanis*, ii), pl. xlii [upper right], cf. p. 45.

Red granite lintel of Amenemhêt I, and blocks from jamb of Amenemhêt I renewed by Sesostri III and Amenemhêt III, found at Tell el-Qirqafa, NAVILLE, *Goshen*, pl. 9 [A 1-3], and p. 22; MASPERO, *Notes sur quelques points de Grammaire et d'Histoire in A.Z.* xxiii. 12 [1-3].

Small red granite sphinx (headless), probably of Sesostri I, found at Tell el-Birka, see id. ib. 11 [lxxv].

Black granite offering-table of Amenemhêt II, in Cairo Mus. 23002; texts, id. ib. 12 [bottom]-13 [top]; KAMAL, *Tables d'Offrandes* (Cat. Caire), 3-4; see MASPERO, *Guide* (1914), p. 107 [323].

Black granite sphinx (headless) of Queen Sebekneferurê', Dyn. XII, found at Tell el-Birka; cartouche, NAVILLE, *op. cit.* pl. 9 [c], cf. p. 21.

Lower part of black granite seated statue of Queen Sent , Dyn. XI or XII, found at Tell Abû el-Filûs, in Cairo Mus. 424, id. ib. pl. 9 [B], cf. p. 22; BORCHARDT, *Statuen und Statuetten* (Cat. Caire), ii, pl. 69, p. 31; MASPERO, *op. cit.* in *A.Z.* xxiii. 12 [3]; see GAUTHIER, *Le Livre des Rois*, i, p. 250 [vii], with note 2.

Blocks with names of Sethos I and Siamûn, found at Tell el-Birka, NAVILLE, *op. cit.* pl. 9 [D, E], cf. p. 21.

QANTÎR, about five kilometres north of Khatâ'na.

PALACE OF SETHOS I, on site of modern cemetery.

See HAMZA, *Excavations of the Department of Antiquities at Qantîr* in *Ann. Serv.* xxx, p. 41, cf. 40, fig. 3.

Fayence tiles, in Louvre, id. ib. pl. iii [D].

WORKSHOPS. Sethos I, Ramesses II, and Dyn. XIX-XX. South-east of Palace.

See id. ib. pp. 41-63, pls. iii, iv.

Fayence tiles of Sethos I and Ramesses II, and inscribed fayence statue of Semitic captive bitten by lion, id. ib. pls. ii, i, cf. pp. 40-2, 46-7.

Fragments of lintels and jambs of Ramesses II; texts, *id. ib.* p. 42.

Hieratic ostraca, mostly of Userma'etre'-nakht Ⓞ , Scribe of the army, *id. ib.* pp. 43-4.

MISCELLANEOUS. (From Qantîr, but exact provenance unknown.)

Lintel and jambs from tomb of Huy , Servant of the Temple of Monthu, temp. Sethos II, in Cairo Mus., GAUTHIER, *Une tombe de la XIX^e dynastie à Qantîr (Delta)* in *Ann. Serv.* xxxii, pp. 116, 118-19, with plate.

Red granite jamb of Teti, re-used in temple of Ramesses II; text, HAMZA, *op. cit.* 34.

Broken tablet of Ramesses III, in Cairo Mus., lintel and base of column, Ramesses II, NAVILLE, *Goshen*, pl. 9 [F, G], *cf. pp.* 22-3.

Trough of Setekh-hirkhopshef , Commander-in-chief, temp. Ramesses II, found outside a house, GRIFFITH, *Tell el Yahûdiyeh*, pl. xix [29], *cf. id.* in PETRIE, *Nebesheh* (in *Tanis*, ii), pp. 45-6.

Fragment of door-jamb of Ramesses II, in Cairo Mus.; texts, DARESSY, *La localit  Khent-nefer* in *Ann. Serv.* xviii. 34.

Lintel, Kha'y  adoring cartouches of Ramesses II; name, HAMZA, *op. cit.* 35.

Fragment of jamb of Ramesses II, with altered cartouches, found in mosque near modern cemetery, now in Cairo Mus.; texts, *id. ib.* 36, 37 [upper].

Block of Ptahmey , Steward of the Temple of Ramesses II, stela with Ramesses II smiting three Asiatics, and fragment of stela with titles of Ramesses II, all found in village; texts, *id. ib.* 37 [lower]-39.

Fragments of reliefs with cartouches of Nektanebos I (Nekht-neb-f), Teos, and Nektanebos II (Nekht-ḥar-ḥebi), in Munich, Mus. Antiker Kleinkunst, SPIEGELBERG, *Reliefbruchst ckchen aus der Zeit der 30. Dynastie* in * .Z.* lxxv, pl. vi, pp. 103-4.

K M SHEIKH RAZ Q

Two fragments from building of Sethos I; texts, EDGAR, *Notes from my Inspectorate* in *Ann. Serv.* xiii. 279.

EL-ṬAW LA

Red granite block from pillar of Nektanebos II (Nekht-ḥar-ḥebi), found in a house, perhaps originally from Tell el-Aḥmar, four miles west, NAVILLE, *Goshen*, pl. 9 [H], *cf. p.* 4.

EL-DIMEIV N

Jamb of Bekenam n , First prophet of goddess Buto in Per-nesu, Dyn. XIX, in Cairo Mus.; text, DARESSY, *La 'Demeure royale' en Basse- gypte* in *Ann. Serv.* xvii. 123.

EL- AW SGA

Ptolemaic stela mentioning 'Granary of Memphis', in Constantinople Mus.; text, DARESSY, *Remarques et Notes* in *Rec. de Trav.* x. 142 [iv]; SCHEIL, *Textes  gyptiens divers du Mus e de Constantinople* in *Rec. de Trav.* xv. 198 [4]; see DARESSY, *op. cit.* in *Ann. Serv.* xvii. 127.

ṢAFT EL-ḤINNA (PHACUSA)

Capital of the XXth nome of Lower Egypt.

NAVILLE, *Goshen and the Shrine of Saft el-Henneh*, *passim.* Plan of site, *id. ib.* pl. 10.

TEMPLE OF SOPT.

Granite naos of Nektanebos I (Nekht-neb-f), in Cairo Mus. 70021.

Blocks, two found by fellahin in 1865, the rest by NAVILLE in 1885, *id. ib.* pls. 1-7,

cf. pp. 2-3, 6-13; ROEDER, *Naos* (Cat. Caire), pls. 17-32, 33 [b], pp. 58-99; see BRUGSCH, *Die Götter des Nomos Arabia* in *Ä.Z.* xix. 15-18; MASPERO, *Guide* (1914), pp. 187-8 [790].

Exterior.

Front, NAVILLE, op. cit. pl. 1; ROEDER, op. cit. pl. 17, pp. 59-62. Another block from upper part, found near Bilbeis, SCHOTT, *Inschriften aus geschichtlicher Zeit in Mitteil. d. Deutsch. Inst. Kairo*, ii, pl. x, p. 56, cf. p. 55, Abb. 3.

Left side, NAVILLE, op. cit. pl. 2; ROEDER, op. cit. pls. 18, 19, 33 [b], pp. 62-8; texts above three registers [NAVILLE, pl. 2 Ba (4-6)] omitting fragment Sb, and texts above second register, BRUGSCH, *Thes.* 787-94 (reversed), 781-2 [D 1, 2]; texts, PIEHL, *Inscr. Hiéro.* i Sér. xli A [first four columns]; text at base [ROEDER, pp. 62-3], BRUGSCH, *Thes.* 781 [c]; PIEHL, op. cit. xli A [fifth to ninth columns]-xlii [first column].

Back, NAVILLE, op. cit. pls. 3-4; ROEDER, op. cit. pls. 20-3, pp. 68-79; left half, second and sixth registers, and texts above second to sixth registers [NAVILLE, Bb], BRUGSCH, *Thes.* 785-6 (reversed), 779-80 [A 1-5]; right half (top to third registers destroyed), texts above fourth to sixth registers [NAVILLE, Ba], PIEHL, op. cit. xlii [second column to fourth column (upper)]; above fifth and sixth registers, BRUGSCH, *Thes.* 782 [D 3, 4]; text at base, id. ib. 780 [A 6], 782 [E]; text on right part [NAVILLE, pl. 4 Ba], PIEHL, op. cit. xlii [fourth column (lower) to sixth column (upper)].

Right side, NAVILLE, op. cit. pls. 5-6; ROEDER, op. cit. pls. 24-31, pp. 79-93; right half, third and fourth registers, and texts above third to sixth registers [NAVILLE, Bb], BRUGSCH, *Thes.* 783-4 (reversed), 780-1 [B, called in error E]; left half, Nektanebos worshipping zodiacal light from fourth register [NAVILLE, pl. 5 (M bottom left); ROEDER, pl. 28], BRUGSCH, *La Lumière Zodiacale* [&c.] in *P.S.B.A.* xv. 391.

Interior.

Right side, NAVILLE, op. cit. pl. 7; ROEDER, op. cit. pls. 18, 32, pp. 93-9.

CEMETERY.

Offering-tables, Ptolemaic, PETRIE, *Hyksos and Israelite Cities*, pls. xxxix, xxxix A.

MISCELLANEOUS. (From Ṣaft el-Hinna, but exact provenance unknown.)

Black granite statue-group, Dyn. XVIII, usurped for Sanwēse , Commander of troops, Prophet of Sopt, with wife and daughter, dedicated by his son Ḥor, Dyn. XXII (?), in Cairo Mus.; texts, DARESSY, *Un groupe de Saft el Henneh* in *Ann. Serv.* xx. 124-6.

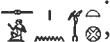



Black granite statue of Ḥor , Commander of troops, Chief of bowmen, son of (the above?) Sanwēse , in Cairo Mus.; texts, id. *Une statue de Saft-el-Henneh* in *Ann. Serv.* xi. 142-4.

Two fragments of black granite colossus of Ramesses II, found in field outside Temple; name on belt, NAVILLE, *Goshen*, pl. 8 [A], cf. pp. 2, 5.

Two fragments of basalt statue of Ramesses II, found in field south of village; one, SCHOTT, *Bericht über die . . . nach dem Ostdelta-Rand unternommene Erkundungsfahrt* in *Mitteil. d. Deutsch. Inst. Kairo*, ii, pl. xi [c], p. 57 [bottom].

Lower part of statue of Kher , Saite (bought in Cairo but presumably from here); texts, WEILL, *Monuments égyptiens divers* in *Rec. de Trav.* xxxvi. 96-7.

Fragment of statue, Saite, NAVILLE, *Mound of the Jew*, pl. ii [d], cf. p. 23.

Fragments of statues of Ḥarwoz (?) , Scribe of the festival of the Palace, Aba , Overseer of scribes of the granary, Aḥmosi , good name Neferebrē'-nakht , Commander of troops, and [Es]ptaḥ , Late Period, in Cairo Mus. 891, 894, 895, 913; texts, BORCHARDT, *Statuen und Statuetten* (Cat. Caire), iii, pp. 141, 142, 150; DARESSY, *Notes et Remarques* in *Rec. de Trav.* xx. 77 [clv, 2^o-5^o].

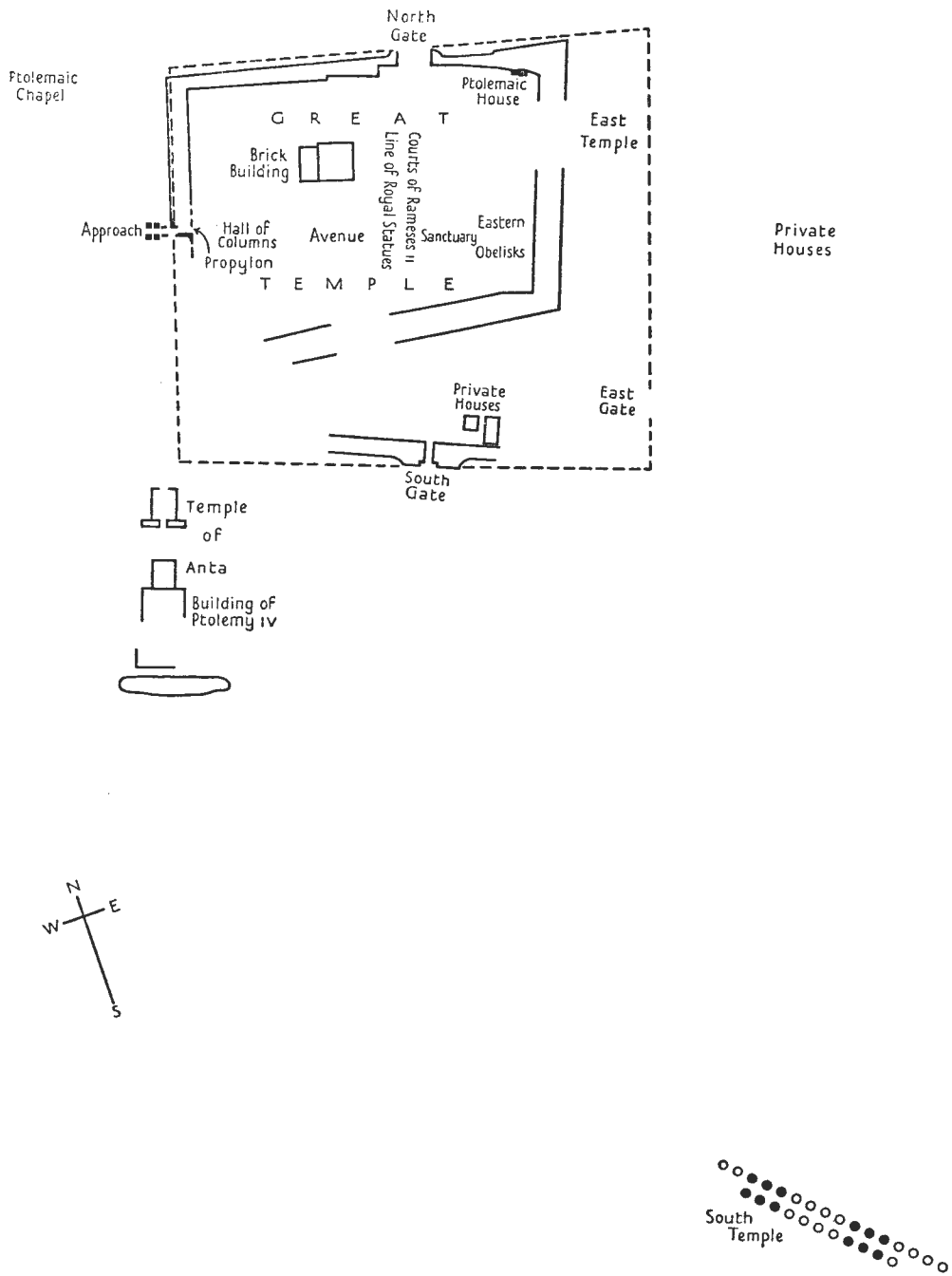

ŞÂN EL-ĦAGAR (TANIS). KEY-PLAN.

Adapted from *Descr. de l'Égypte, Ant.* v, pl. 28; PETRIE, *Tanis*, i, plans at end; MONTET, *Les Nouvelles Fouilles de Tanis (1929-32)*, pl. v.

Squatting statue of Zehō  (?), Prophet of Mendes, in Cairo Mus.; texts, id. ib. 76-7 [clv, 1°].

Grey granite statue (head and feet missing) of Nektanebos I (Nekht-neb-f), bought by NAVILLE, in Brit. Mus. 1013, EVERS, *Staat aus dem Stein*, ii, pl. x [59]; text on back, NAVILLE, *Goshen*, pl. 8 [B], cf. p. 5; PIEHL, *Inscr. Hiéro.* 3 Sér. xiv P, cf. p. 11; see *Guide, Sculpture* (1909), p. 250 [925].

Red granite block of Nektanebos II (Nekht-ḥar-ḥebi), re-used as corner stone, found in village, NAVILLE, op. cit. pl. 8 [C], cf. p. 5.

Stela, year 22 of Ptolemy II Philadelphus and Arsinoë II, sunk in pond outside village, id. ib. pl. 8 [D], cf. p. 13; titles of queen, SETHE, *Urk.* ii. 107 (21) D.

B. MAṬARIYA TO TELL BASTA (BUBASTIS)

MAṬARIYA

Cartouche of Teos, Dyn. XXX, on block built into doorway, EDGAR, *Notes from my Inspectorate in Ann. Serv.* xiii. 277.

TELL TENNIS

Base of kneeling statue with Horus-name of Psusennes I, in Cairo Mus.; name, GAUTHIER, *Le Livre des Rois*, iii. 290 [vii].

ṢÂN EL-ḤAGAR (TANIS)

Capital of the XIVth nome of Lower Egypt after Dyn. XX.

See MARIETTE, *Fragments et documents relatifs aux fouilles de Sân* in *Rec. de Trav.* ix. 2-20; id. *Notice des principaux monuments du Musée à Boulaq* (1864), 258-60; PETRIE, *Tanis*, 2 vols.; MONTET, *Les Ruines de San* in *Bull. de la Faculté des Lettres de Strasbourg*, vii, pp. 1-8, pls. i, ii; id. *Les Nouvelles Fouilles de Tanis (1929-1932)*, passim. Description, BURTON MSS.* 25634, 19; NESTOR L'HÔTE MSS.* 20396, 357-8, 361. Plans of site, DENON, *Voyage* (1802), 17 [2]; *Descr. de l'Égypte, Ant.* v, pl. 28, cf. *Texte*, v, pp. 99-121, x, pp. 497-500; RIFAUD, *Voyage*, 143; MONTET, op. cit. in *Bull. . . . Strasbourg*, vii, p. 9; id. *Les Nouvelles Fouilles* [&c.], pl. v; WILKINSON MSS.* xvii. J. 9; incomplete, BURTON, *Excerpta Hiero.* xli [right]. Views, MONTET, *Les Nouvelles Fouilles* [&c.], pls. i, vi-viii.

GREAT TEMPLE (ruined).¹

Plan, L. D. i. 55 [lower right], and *Text*, i, p. 218 [upper left]; PETRIE, *Tanis*, i, plans at end; BURTON MSS.* 25634, 20. Views during excavation in 1865, DE ROUGÉ, *Album Photo.* 87, 88. List of monuments brought to Cairo Museum in 1903, BARSANTI, *Rapport* in MASPERO, *Transport des gros monuments de Sân au Musée du Caire* in *Ann. Serv.* v. 210-12. See also addenda, infra p. 270.

APPROACH. Probably Sesonchis II.²

See MONTET, *Les Nouvelles Fouilles* [&c.], pp. 54-61, cf. pl. xiv [upper].

Monuments originally on either side of Approach (from west to east).

Two bases with re-used granite blocks, twelve metres from Propylon, one with name

¹ Numbers in heavy type are those of PETRIE, *Tanis*, i, plans at end.

² Called Sesonchis III by PETRIE, but see GAUTHIER, *Le Livre des Rois*, iii. 366 [xxvi].

of Tuy () , mother of Ramesses II ; sketch, and cartouche of Queen, MARIETTE, op. cit. in *Rec. de Trav.* ix. 17-18 ; see MONTET, op. cit. p. 55.

Two colossi of Ramesses II ; remains of south colossus (sandstone with granite base), with Queen by left leg, id. ib. pls. xix, xx [1, 3] ; remains of north colossus (black granite), id. ib. pl. xx [1, 2].

Two red granite colossi (7, 9), usurped by Ramesses II, with Queen near leg, id. ib. pls. xxii-xxiii, cf. xxi [left] ; texts, PETRIE, op. cit. i, pl. v [33, 34], cf. p. 24 ; ii, p. 20.

On south side, granite statue-group (10), Ramesses II standing between Rē^c-Ḥarakhti and Ptaḥ, MONTET, op. cit. pls. xii [left], xxi [right upper], xxiv, xxv [1] ; texts, PETRIE, op. cit. i, pl. vi [43 A, B], cf. p. 25 ; ii, p. 21. Blocks of Pepy I and bas-relief of Shu with cartouches of Ramesses II, re-used beneath statue-group and still *in situ*, MONTET, op. cit. pls. xxi [right lower], xxvi.

On north side, three statues, Min (or Amūn), a King, and Ptaḥ ; heads, id. ib. pl. xxv [2-4].

Finds.

Fragment of colossus with Ramesses II as sphinx on base, and re-used granite block, a King with Sēth and another god, latter found near north jamb of Propylon, id. ib. pls. xx [4], x, cf. xiv [upper].

GRANITE PROPYLON. Sesonchis II.¹

See MONTET, *Les Fouilles de Tanis en 1930* in *Bull. . . Strasbourg*, ix, pp. 3-4 ; id. *Les Fouilles de Tanis en 1931* in ib. x, pp. 1-2 ; id. *Les Nouvelles Fouilles* [&c.], pp. 45-54. View in 1928, id. op. cit. in *Bull. . . Strasbourg*, vii, pl. i [upper].

Reconstruction of south jamb, id. *Les Nouvelles Fouilles* [&c.], pl. xviii.

Remains of jambs *in situ*, and blocks from them (some re-used from colossus of Ramesses II), id. ib. pls. x, xi, xii [right], xiii, xiv [lower], xv [3, 4], xvi, xvii ; west face of north jamb, PETRIE, op. cit. i, pl. xv [1] ; blocks (26, 28, 29, 33, 34, 36) from colossus, id. ib. ii, pl. vi [110-18], cf. pp. 10-11, 28 ; i, p. 14.

Remains (27) of sandstone obelisk of Ramesses II, id. ib. i, pl. x [56], cf. p. 26 ; ii, p. 23.

Granite stela (8) with weathered inscription, id. ib. ii, pl. iii [80], cf. p. 26 ; i, p. 18.

Block (38) with Nekhbet as vulture, attributed to Siamūn, id. ib. ii, pl. viii [152], cf. pp. 12, 29.

Blocks of Siamūn and Sesonchis II, id. ib. pls. viii [155-6], ix [157-62], cf. pp. 12, 29.

Block with name of Ḥapi ; name, L. D. *Text*, i, p. 217 [bottom].

Fragments of obelisk of Pepy II, MONTET, op. cit. pl. xv [1, 2].

HALL OF COLUMNS. Originally Ramesses II, usurped probably by Sesonchis II. Columns (39, 42, 44).

Limestone papyrus-columns of Psusennes I (destroyed), see id. ib. p. 63.

Granite palm-columns usurped from Ramesses II, id. ib. pls. xxviii, xxxi [lower], and pp. 64-5, figs. 1, 2 ; texts, PETRIE, *Tanis*, ii, pl. v [102-4], cf. pp. 10, 27-8 ; i, p. 14 ; one with added cartouche of Osorkon II, L. D. *Text*, i, p. 219 ; RIFAUD, *Voyage*, 92 [1] ; part of text, BURTON, *Excerpta Hiero.* xl [6] (inaccurate) ; part of text of one [= PETRIE, 102], MARIETTE, op. cit. in *Rec. de Trav.* ix. 8.

Western Obelisks.

North obelisk (47, 46). Three faces, DE ROUGÉ, *Inscr. Hiéro.* ccxciv ; BURTON, op. cit. xxxix ; PETRIE, op. cit. i, pl. vii [44], cf. pp. 14, 25 ; ii, pp. 21-2 ; one face [second

¹ See note 2 on previous page.

of PETRIE], *Descr. de l'Égypte, Ant.* v, pl. 29 [13]; NESTOR L'HÔTE MSS.* 20396, 357 [left]; central part of texts of four faces, MONTET, op. cit. pl. xxix, cf. pp. 70-2.

South obelisk (43 called 42 on plate), lying on ground. Views, id. ib. pls. xxx, xxxi [upper], cf. pp. 72-3; first to third faces, PETRIE, op. cit. i, pl. vii [45], cf. pp. 14, 25; ii, p. 22, cf. errata on p. 39; first, second, and fourth faces (fourth turned towards ground in PETRIE'S time), DE ROUGÉ, *Inscr. Hiéro.* ccxcvi [left].

Near Obelisks.

Stela (48) with trilingual decree of Canopus, year 9 of Ptolemy III Euergetes I, found in 1866 (probably from Ptolemaic temple, the pavement of which was found south of Temple Enclosure, see PETRIE, op. cit. i, p. 14), in Cairo Mus. 22187, BUDGE, *The Decrees of Memphis and Canopus*, iii, folding sheet opposite p. 35, cf. pp. 35-8; hieroglyphic and Greek texts, LEPSIUS, *Das Bilingue Dekret von Kanopus*, passim with eight plates; REINISCH and ROESLER, *Die Zweisprachige Inschrift von Tanis*, passim with seven plates; SETHE, *Urk.* ii. 125-154 (30) T; Greek text, and first ten and a half lines of hieroglyphic text, LEPSIUS, *Entdeckung eines bilinguen Dekretes durch Lepsius in Ä.Z.* iv, second plate at end, and pp. 33-4; hieroglyphic and demotic texts, BRUGSCH, *Thes.* 1554-1575, cf. 326; hieroglyphic text, REINISCH, *Aegyptische Chrestomathie*, pl. 17; PIERRET, *Le Décret trilingue de Canope*, passim; see MASPERO, *Guide* (1914), pp. 217-18 [980]; KAMAL, *Sîtles Ptolémaïques et Romaines* (Cat. Caire), p. 183.

AVENUE.

Sphinxes.

Colossal red granite pair (51), Middle Kingdom, usurped. Sphinx in Louvre A. 23, with cartouches of Merneptah on chest and right shoulder, and of Sesonchis I on base and left shoulder, CLARAC, *Musée de Sculpture*, ii, pl. 245 [bottom], No. 396; v, pl. 1000 [bottom]; DURANTY, *Remarques à propos de l'art égyptien in Gazette des Beaux Arts*, xix (1879), p. 336; JÉQUIER, *L'Architecture*, i, pl. 18 [2]; CAPART, *Les Monuments dits Hycsos*, p. 43, fig. 28 (reprinted from *Ann. Soc. Roy. d'Arch. Bruxelles*, xxvii, 1913); BISSING, *Denkmäler*, Text to 38 A [1st fig.]; EVERS, *Staat aus dem Stein*, i, pls. 48-50; BOREUX, *Guide Catalogue Sommaire* (1932), i, pl. i, cf. p. 38; texts, PETRIE, *Tanis*, i, pl. ii [14 A-F], cf. pp. 7-8; erased names, DEVÉRIA, *Note additionnelle à une lettre . . . sur quelques monuments relatifs aux Hyq-s'os in Rev. Arch.* 2^e Sér. iv (1861), p. 261, reprinted in *Bibliothèque Ég.* iv. 222. Sphinx in Cairo Mus., with cartouches of Merneptah and Siamun on left shoulder, and of Sesonchis I on base, EVERS, op. cit. ii, pl. xi [60]; texts, PETRIE, op. cit. i, pl. ii [15 A-C], cf. pp. 8, 15; ii, p. 18; on left shoulder, MARIETTE, op. cit. in *Rec. de Trav.* ix. 15 [x].

Obelisks. Ramesses II.

See PETRIE, op. cit. i, pp. 25-6.

First pair. North obelisk (49); first to third faces, DE ROUGÉ, *Inscr. Hiéro.* ccxcv; PETRIE, op. cit. i, pl. viii [50], cf. pp. 15, 25; ii, p. 23; first, second, and fourth faces, BURTON, *Excerpta Hiero.* xxxviii, xl [4]; two faces [second and third of PETRIE], NESTOR L'HÔTE MSS.* 20396, 357 [middle right and right]; one face, see view *in situ*, DE ROUGÉ, *Album Photo.* 87 [left].

Second pair. North obelisk (57); injured texts from four faces, PETRIE, op. cit. i, pl. vii [46], cf. pp. 15, 25; ii, p. 22. South obelisk (58); three faces, id. ib. pl. vii [47], cf. p. 15; ii, p. 22; first and second faces, DE ROUGÉ, *Inscr. Hiéro.* ccxcvi [2^e Pylone]; BURTON, op. cit. xl [2, 3]; first face, NESTOR L'HÔTE MSS.* 20396, 357 [middle left].

Third pair. North obelisk (76); four faces, PETRIE, op. cit. i, pl. viii [48], cf. p. 26;

ii, p. 22; fourth and second faces, DE ROUGÉ, *Inscr. Hiéro.* ccxcvii [middle left]; fourth face, MARIETTE, op. cit. in *Rec. de Trav.* ix. 9 [middle right]; second face, see view *in situ*, DE ROUGÉ, *Album Photo.* 87 [middle]. South obelisk (59); part of four faces, PETRIE, op. cit. i, pl. viii [49], cf. p. 26; ii, pp. 22-3; first, third, and fourth faces, DE ROUGÉ, *Inscr. Hiéro.* ccxcvii [right].

Fourth pair. North obelisk (77); first, second, and fourth faces, PETRIE, op. cit. i, pl. ix [51], cf. p. 26; ii, p. 23; second and third faces (latter turned towards ground in PETRIE'S time), DE ROUGÉ, *Inscr. Hiéro.* ccxcvii [left]; first and second faces, MARIETTE, op. cit. 9 [top]. South obelisk (62) (upper part with pyramidion, in Cairo Mus. 17022); third, first, and fourth faces, PETRIE, op. cit. i, pl. ix [52], cf. p. 26; ii, p. 23; third face, omitting pyramidion, DE ROUGÉ, op. cit. ccxcvii [middle right]; upper part and pyramidion, KUENTZ, *Obélisques* (Cat. Caire), pl. xii, pp. 39-41; second face, ENGELBACH, *Evidence for the use of a Mason's Pick in Ancient Egypt in Ann. Serv.* xxix, pl. 1, cf. p. 20.

Base (79) of another, PETRIE, op. cit. i, pl. xi [63 A, B], cf. p. 26; ii, p. 24.

Sandstone colossi of Ramesses II.

First pair, between first and second pair of obelisks. South colossus (54), King and Princess Bent'anta; texts, id. ib. i, pl. v [37 A, B, C], cf. pp. 15, 24; ii, p. 21; see MARIETTE, op. cit. 13 [11].

Second pair, between second and third pair of Obelisks. South colossus (68), King with Princesses Merytamün and Bent'anta; bust of king, DE ROUGÉ, *Album Photo.* 129; texts, PETRIE, op. cit. i, pl. v [35 A-F], cf. pp. 15, 24; ii, p. 20; cartouches and pectoral of King, MARIETTE, op. cit. 10 [2° lower], 12-13 [1]. North colossus (69), King with Queen Mat-neferu-ré'  and Princess Merytamün; texts, PETRIE, op. cit. i, pl. v [36 A, B, C], cf. pp. 15, 24; ii, pp. 20-1; texts of Queen and Princess, DE ROUGÉ, *Inscr. Hiéro.* lxxiv [bottom]; MARIETTE, op. cit. 10 [2° upper], 13 [iii].

So-called 'Hyksos' Monuments in black granite.

Four of the sphinxes near the last colossi, found by MARIETTE in 1860 and 1861 (parts of two then taken to the Cairo Museum and the remainder in 1904), see MARIETTE, *Notice des principaux monuments* [&c.] (1864), pp. 233-5 [11], 264 [11-13]; MASPERO, *Guide* (1914), pp. 141-3 [500-503].

First sphinx (73, 74), in Cairo Mus. 394, JÉQUIER, *L'Architecture*, i, pl. 18 [1]; BORCHARDT, *Statuen und Statuetten* (Cat. Caire), ii, pl. 64, pp. 12-13; EVERS, *Staat aus dem Stein*, i, pls. 121-3; forepart, DE ROUGÉ, *Album Photo.* 122; MARIETTE, *Lettre à M. de Rougé* [&c.] in *Rev. Arch.* 2° Sér. iii (1861), pl. 4, cf. pp. 104-7; GOLÉNISCHEFF, *Amenemhâ III et les Sphinx de 'Sân'* in *Rec. de Trav.* xv, pls. ii [right], iii [right], iv [right], after p. 136; CAPART, *L'Art Égyptien* (1911), pl. 133; BISSING, *Denkmäler*, 25-6; WEIGALL, *Anc. Eg. Works of Art*, 102, 103 [upper]; BORCHARDT and REISNER, *Works of Art*, 7; PETRIE, *A History of Egypt*, i (1923), p. 126, fig. 78; head, id. *Racial Types*, 794, 795 (sheet xiv); *Anc. Eg.* (1916), fig. on p. 188; BLACKMAN in ROSS, *The Art of Egypt through the Ages*, 132 [2]; ENGELBACH, *The so-called Hyksos Monuments in Ann. Serv.* xxviii, pl. i [3]; MASPERO and ROEDER, *Führer* (1912), pl. 19; texts on sides of base, PETRIE, *Tanis*, i, pl. iv [30 B, 31 A], cf. pp. 11, 15; ii, p. 20; cartouches of Ramesses II on base, of Merneptah on shoulders (superseding those of Apophis II), of Pinezem I or Psusennes I, on chest, MARIETTE, op. cit. in *Rec. de Trav.* ix. 11 [1]; see GAUTHIER, *Le Livre des Rois*, iii. 250 [xxvi].

Second sphinx (72), in Cairo Mus. 393, MASPERO, *Hist. Anc. des Peuples de l'Orient, Les Origines*, fig. on p. 503; BORCHARDT, op. cit. ii, pl. 63, pp. 11-12; EVERS, op. cit. i, pl. 120; WEIGALL, op. cit. 103 [lower]; forepart, MASPERO, *Guide* (1914), p. 142,

fig. 43; cartouches of Ramesses II and of Merneptah on base, of Merneptah on shoulders, and of Psusennes I on chest and base, MARIETTE, op. cit. 11 [2]; cartouche of Psusennes I, BRUGSCH, *An den Herausgeber in Ä.Z.* ix. 125 [near bottom]; texts from shoulders, front and left side of base, and chest, PETRIE, *Tanis*, i, pl. iv [28 B-F], cf. xiii [5 middle], pp. 11, 15; ii, p. 20; right side, MARIETTE, op. cit. in *Rev. Arch.* 2^o Sér. iii (1861), pl. 5.

Fragment of third sphinx (71), with cartouches of Ramesses II, Merneptah and Psusennes I, DE ROUGÉ, *Album Photo.* 120, 121; texts from left side of base, left shoulder and chest, PETRIE, op. cit. i, pl. iv [29 A-C], cf. xiii [5 lower], pp. 11, 15; ii, p. 20; see MARIETTE, op. cit. in *Rec. de Trav.* ix. 11 [3].

Fourth sphinx; cartouches of Ramesses II and of Merneptah on base, of Merneptah on shoulders, and of Psusennes I on chest, CAPART, *Les Monuments dits Hyksos*, p. 7, fig. 1 (reprinted from *Ann. Soc. Roy. d'Arch. Bruxelles*, xxvii, 1913); BISSING, *Denkmäler*, Text to 25 and 26 [fig.]; see MARIETTE, op. cit. in *Rec. de Trav.* ix. 11 [4].

Fragments of two other sphinxes (60, 61), with cartouches of Apophis II (erased), Ramesses II, Merneptah, and Psusennes I, PETRIE, op. cit. i, pl. iv [26 A-B, 27 A-G], cf. pp. 11, 15; ii, pp. 19-20.

Pair of granite statue-groups, each consisting of two Nile-gods holding offering-tables with fish and lotuses, with text of Psusennes I on front and back, in Cairo Mus. 392, 531, DE ROUGÉ, op. cit. 116-18; see PETRIE, op. cit. i, p. 11. No. 392 (southern), MARIETTE, *Deuxième Lettre à M. de Rougé sur les Fouilles de Tanis* in *Rev. Arch.* 2^o Sér. v (1862). pls. vi, vii; BISSING, *Denkmäler*, 56; *Anc. Eg.* (1916), second plate after p. 192; MASPERO, *Hist. Anc. des Peuples de l'Orient, Les Premières Mêlées*, fig. on p. 764; id. *Guide* (1914), p. 143, fig. 44, cf. pp. 143-4 [504]; BORCHARDT, *Statuen und Statuetten* (Cat. Caire), ii, pl. 63, pp. 9-11; CAPART, op. cit. pp. 11, 27, 29, figs. 2, 11, 15; EVERS, *Staat aus dem Stein*, i, pls. 129-30; WEIGALL, *Anc. Eg. Works of Art*, 104; MASPERO and ROEDER, *Führer* (1912), pl. 20 [b]; PETRIE, *A History of Egypt*, i (1923), p. 127, fig. 80; upper part, id. *Racial Types*, 799 (sheet xiv); one head, ENGELBACH, op. cit. in *Ann. Serv.* xxviii, pl. ii [3]. No. 531 (northern), fragments only, removed to Cairo Mus. in 1904, BORCHARDT, op. cit. ii, pl. 89, cf. p. 83.

Found lying near 'Hyksos' Monuments.

Grey granite statue (70) of Merneptah standing with god-headed standards, RIFAUD, *Voyage*, 125 [17-19] (inaccurate); texts, PETRIE, *Tanis*, ii, pl. vii [136], cf. pp. 11, 28; i, p. 15.

Lower part of sandstone kneeling statue (158) holding offering-table, and grey granite kneeling statue (near 70) holding naos containing Ptah and Sekhmet, both Ramesses III, latter in Cairo Mus.; texts, id. ib. ii, pl. vii [142, 143], cf. pp. 11, 29; i, p. 15; former, see MARIETTE, *Notice des principaux monuments [&c.]* (1864), p. 267 [22].

Grey granite kneeling statue (75) of Osorkon II holding stela, in Cairo Mus., PETRIE, op. cit. i, pl. xiv [3], cf. pp. 15, 25, and corrections, ii, p. 37; texts from stela mentioning Queen Kera'm', DE ROUGÉ, *Inscr. Hiéro.* lxxi-lxxii [upper]; DARESSY, *Inscriptions inédites de la XXII^e dynastie* in *Rec. de Trav.* xviii. 49-50; fragments from base, &c., PETRIE, op. cit. i, pl. vi [41 A-D], cf. p. 21.

Pair of sandstone naos of Ramesses II, dedicated to Rē'-Harakhti, Atum, and Khepri, between third and fourth obelisks, in Cairo Mus. 70003, 70004, see MASPERO, *Guide* (1914), p. 161 [611]; MASPERO and ROEDER, *Führer* (1912), p. 15 [511, 511 bis]. Northern naos (80), No. 70003, DE ROUGÉ, *Album Photo.* 138; PETRIE, op. cit. i, pl. xvi [6], cf. p. 15; ii, pl. i [68], cf. pp. 24-5; back, ROEDER, *Naos* (Cat. Caire), pl. 4, pp. 11-19. Southern naos (63), No. 70004, id. ib. pl. 5, pp. 19-22; see PETRIE, op. cit. ii, pl. i [68], pp. 24-5; i, p. 15.

Portion of red granite sphinx with cartouche of Siamūn (?) on chest (apparently that mentioned by PETRIE, op. cit. i, p. 8, as being without visible inscription), found near naos; cartouche, MARIETTE, op. cit. in *Rec. de Trav.* ix. 15 [xi].

Other remains from Avenue.

Two red granite blocks (96, 113) of Pepy I, PETRIE, op. cit. i, pl. i [1, 2], cf. p. 4; ii, p. 15; second block, DE ROUGÉ, *Inscr. Hiéro.* lxxv [lower right]; id. *Recherches sur les Monuments* [&c.], pp. 115-16.

Granite blocks (52, 65, 66) of Ramesses II, PETRIE, op. cit. ii, pl. vi [133-5], cf. pp. 11, 28; i, p. 16.

Fragments, Siamūn (100, 122, 160, 116), id. ib. ii, pl. viii [147, 149, 150, 154], cf. pp. 12, 29; part of granite cornice [= PETRIE, viii (150)], id. *A History of Egypt*, iii (1923), p. 224, fig. 91.

Small Obelisks at east end of Avenue.

Two obelisks (117, 136), usurped by Ramesses II; texts, id. *Tanis*, i, pls. iv [21 A, B], x [55, 59], cf. pp. 9, 26; ii, pp. 19, 23, 24; of (117), NESTOR L'HÔTE MSS.* 20396, 357 verso [bottom right].

TRANSVERSE LINE OF ROYAL STATUES.

Colossal red granite statue (103) of Amenemhēt I, usurped by Merneptah, in Cairo Mus., EVERS, *Staat aus dem Stein*, i, pls. 15-17; texts and head, PETRIE, op. cit. i, pls. i [3 A-D], xiii [1], cf. pp. 4-5; ii, pp. 15-16; head, id. *A History of Egypt*, i (1923), p. 155, fig. 94; WARD, *A Collection of Historical Scarabs* [&c.] in *P.S.B.A.* xxii, fig. on p. 309; right side of throne, DE ROUGÉ, *Album Photo.* 109; see MARIETTE, *Notice des principaux monuments* [&c.] (1864), p. 260 [1].

Three colossal black granite statues of Sesostris I, usurped by Merneptah, one in Berlin Mus., two in Cairo Mus. Statue, in Berlin Mus. 7265, *Aeg. und Vorderasiat. Alterthümer*, pl. 1 [back right]; sides of throne, RIFAUD, *Voyage*, 123 [6, 7]; right side of throne, and legs of king, EVERS, *Staat aus dem Stein*, i, pl. 41; right side of throne, *Aeg. und Vorderasiat. Alterthümer*, pl. 99; SCHÄFER, *Von ägyptischer Kunst* (1919), pl. 24; (1930), pl. 20; SCHÄFER and ANDRAE, *Die Kunst des alten Orients*, 285; back, cartouche of King, and prince with libation and incense before Sēth, BRUGSCH, *Tanis und Avaris in Zeitschr. d. Gesell. f. allg. Erdkunde*, Neue Folge xii (1862), pl. A [1, 2], cf. p. 401; figure and text of Sēth, MEYER, *Darstellungen der Fremdvölker*, 655; texts, *Aeg. Inscr. Mus. Berlin*, i. 141-3, cf. 269, ii. 19-22; texts from front of throne and left side of edge of base, BURTON, *Excerpta Hiero.* xl [5, 10]; name of Sēth, BRUGSCH, *Aegyptische Studien in Zeitschr. d. Deutsch. Morgenland. Gesell.* ix, p. 212, and pl. iv [25]; see *Ausführ. Verzeichnis* (1899), pp. 79-80. Statue (101), in Cairo Mus. 37465, EVERS, op. cit. i, pls. 37, 38; bust, PETRIE, *A History of Egypt*, i (1923), p. 164, fig. 97; DE ROUGÉ, *Album Photo.* 110; texts and bust, PETRIE, *Tanis*, i, pls. i [4 A-D], xiii [2], cf. p. 5; ii, p. 16; see MARIETTE, op. cit. pp. 260-1 [2]; MASPERO, *Guide* (1914), p. 164 [625]. Headless statue (97), in Cairo Mus. 37482, EVERS, op. cit. i, pls. 39, 40; throne and torso, PETRIE, op. cit. i, pls. ii [5 A-C], xiii [3, 4], cf. pp. 5-6; ii, p. 16 (called Amenemhēt II); see MARIETTE, op. cit. p. 261 [3].

Base of colossal grey granite seated statue (87) of Sesostris I, usurped by Merneptah, PETRIE, op. cit. i, pl. ii [8 A, B], cf. p. 6; ii, pp. 16-17.

Fragments of sandstone statue of Sesostris II (?); texts, id. ib. i, pl. ii [6 A, B], cf. p. 6; ii, p. 16.

Black granite seated statue of Queen Nofret $\frac{1}{6}$ $\frac{1}{6}$, wife of Sesostris II, in Cairo Mus. 382, MASPERO, *Hist. Anc. des Peuples de l'Orient, Les Origines*, fig. on p. 501; DE ROUGÉ,

op. cit. 113; BORCHARDT, *Statuen und Statuetten* (Cat. Caire), ii, pl. 50, p. 2; BISSING *Denkmäler, Text* to 21, 22 [fig.]; CAPART, *L'Art Égyptien* (1909), pl. 38; EVERS, op. cit. i, pls. 72-3; BLACKMAN in ROSS, *The Art of Egypt through the Ages*, p. 126; MASPERO, *Guide* (1914), p. 95, fig. 29, cf. p. 96 [286]; bust, PETRIE, *A History of Egypt*, i (1923), p. 182, fig. 107; texts, DE ROUGÉ, *Inscr. Hiéro.* lxxv [left and upper right]; PETRIE, *Tanis*, ii, pl. xi [171], pp. 13, 31; cf. i, p. 6; omitting pectoral, BRUGSCH, *An den Herausgeber* in *A.Z.* ix. 125 [upper].

Black granite seated statue of same Queen (legs broken off), in Cairo Mus. 381, BORCHARDT, op. cit. ii, pl. 60, cf. pp. 1-2; BISSING, *Denkmäler*, 21, 22; EVERS, op. cit. pls. 74-5; remains of text on throne, possibly from this statue (85 called 83 on plate), PETRIE, op. cit. i, pl. ii [12], cf. p. 6; ii, p. 17.

Head of black granite statue of princess, Middle Kingdom, DE ROUGÉ, *Album Photo.* 128; remains of text from fragment of back, MARIETTE, op. cit. in *Rec. de Trav.* ix. 14-15 [ix].

Block (95), Middle Kingdom, with fragment of text, PETRIE, op. cit. i, pl. ii [9], cf. p. 6.

Pair of grey granite colossal statues (86, 98) of Smenkhkarē Mre-mesha , Dyn. XIII, with cartouches of Apophis II on right shoulder, and texts of Ramesses II on back and side of throne, in Cairo Mus., see MASPERO, *Guide* (1914), pp. 164, 165 [621, 632]; combined texts, PETRIE, op. cit. i, pl. iii [17 A-C], cf. pp. 8-9; ii, p. 18. South statue, with texts of Mre-mesha on throne by right leg, of Apophis on right shoulder, and of Ramesses II on left side of throne and back, RIFAUD, *Voyage*, 92 [5, 6]; statue, EVERS, op. cit. i, pls. 146-7; texts by leg and on shoulder, BURTON, *Excerpta Hiéro.* xl [1, 7]; *L. D.* iii. 259 c, and *Text*, i, p. 5 [top right], cf. p. 218 [upper right]; text on shoulder, PETRIE, op. cit. i, pl. xiii [6]; reversed, DE ROUGÉ, *Inscr. Hiéro.* lxxvi [lower right]; text by leg, MARIETTE, op. cit. in *Rec. de Trav.* ix. 12 [5]; text on back, *L. D. Text*, i, p. 218 [lower left]; side of throne, EVERS, op. cit. ii, pl. iii [37]; feet and remains of texts (perhaps from this statue), RIFAUD, op. cit. 92 [8]. North statue, DE ROUGÉ, *Album Photo.* 114, cf. 88 [middle]; MASPERO, *Hist. Anc. des Peuples de l'Orient, Les Origines*, fig. on p. 533; PETRIE, *A History of Egypt*, i (1923), p. 217, fig. 123; EVERS, op. cit. i, pl. 148; texts of Mre-mesha and Apophis, DE ROUGÉ, *Inscr. Hiéro.* lxxvi [upper right].

Pair of red granite colossal statues (102) of Sebekhotp IV ,¹ see GAUTHIER, *Le Livre des Rois*, ii, p. 33 [ix] with note 3. Statue in Cairo Mus., EVERS, op. cit. i, pls. 144, 145; bust, PETRIE, op. cit. i, p. 225, fig. 130; texts on front of throne, id. *Tanis*, i, pl. iii [16 A, B], cf. p. 8; ii, p. 18; DE ROUGÉ, op. cit. lxxvi [left]; see MASPERO, *Guide* (1914), p. 165 [630]. Statue in Louvre A. 16, RIFAUD, op. cit. 123 [3]; PERROT and CHIPIEZ, *Hist. de l'Art*, i. 679; MASPERO, *Hist. Anc. des Peuples de l'Orient, Les Origines*, fig. on p. 529; BISSING, *Denkmäler*, 28; part of text by right leg, SHARPE, *Eg. Inscr.* 2 Ser. 38, l. 30; see PETRIE, *Tanis*, i, p. 8; MARIETTE, *Lettre à M. le Vicomte de Rougé sur les Fouilles de Tanis* in *Rev. Arch.* 2^o Sér. iii (1861), pp. 102-3, note 2; BOREUX, *Guide-Catalogue Sommaire* (1932), i, pp. 42-3.

Black granite statue (99) of a queen altered to Tuy (name destroyed), mother of Ramesses II, in Cairo Mus., PETRIE, op. cit. i, pls. ii [11], xiv [1], cf. pp. 6-7; ii, p. 17; DE ROUGÉ, *Album Photo.* 127; texts, MARIETTE, op. cit. in *Rec. de Trav.* ix. 14 [viii]; see id. *Notice des principaux monuments* [&c.] (1864), p. 267 [20].

¹ For statue of Sebekhotp IV, in Louvre A. 17, perhaps from here, see Tôd in later volume of this Bibliography.

Granite statues (**81, 82**) of Ramesses II; texts, PETRIE, *op. cit.* i, pl. vi [38 A, B, 39 A-C], cf. pp. 15-16; ii, p. 21.

Red granite head (**83**) of Ramesses II from group, *id. ib.* i, pl. xiv [2], cf. p. 25.

Block (**104**) of Ramesses II or later king, lying near, *id. ib.* ii, pl. vii [144 A, B], cf. pp. 11, 29.

Grey granite statue (**106**) of Merneptah with standard; texts, *id. ib.* pl. vii [137], cf. pp. 11, 28-9.

COURTS OF RAMESES II.

Jamb (**134**) of pylon and lintels (**147, 124, 128-130**) of Ramesses II, *id. ib.* pl. vi [109, 123, 127], cf. pp. 10, 11, 28; i, p. 16; remains of scenes on jamb with Ptah and Mut [PETRIE, vi (109 B)], NESTOR L'HÔTE MSS.* 20396, 357 verso [right].

Offering-table (**105**) of Ramesses II, in Cairo Mus. 23250, PETRIE, *op. cit.* ii, pl. i [66], cf. pp. 9, 24; i, p. 16; texts, KAMAL, *Tables d'Offrandes* (Cat. Caire), p. 168.

Similar offering-table (**115**), PETRIE, *op. cit.* ii, pl. i [67], cf. pp. 9, 24; i, p. 16.

Two granite blocks (**118, 142**), Merneptah before Nefertum, and before hawk-god, *id. ib.* ii, pl. vii [139, 140], cf. pp. 11, 29; block with Nefertum, NESTOR L'HÔTE MSS.* 20396, 357 verso [left]; texts, L. D. *Text*, i, pp. 5 [top, near right], 218 [lower right].

Block (**141**) of Sethos II, PETRIE, *op. cit.* ii, pl. vii [141], cf. pp. 11, 29.

Lintel (**138**) of Siamun, *id. ib.* pl. viii [148], cf. p. 12; i, p. 16.

Fragments of painted chamber, probably Dyn. XXII or XXVI, see *id. ib.* i, p. 16.

Granite stela (**89, 93**) of Taharqa, in two fragments, *id. ib.* ii, pl. ix [163], cf. pp. 12, 29-30; i, p. 16; texts of lower part, DE ROUGÉ, *Inscr. Hiéro.* lxxiii, lxxiv [top]; *id. Étude sur quelques monuments du règne de Taharqa* in *Mélanges d'Archéologie*, i. 21-3; 22nd line with cartouche, BURTON, *Excerpta Hiéro.* xl [12].

GRANITE SANCTUARY. Siamun, rebuilt by Psusennes I.

Two pairs of obelisks of Ramesses II, in front of Sanctuary; three of them (**168, 167, 163**), PETRIE, *op. cit.* i, pls. x [57, 58], xi [60], cf. pp. 9-10, 17; ii, p. 24.

Blocks (**228, 229, 179, 169, 219, 220, 212, 213**) of Ramesses II, *id. ib.* ii, pl. iv [94-101], cf. pp. 10, 27; i, pl. xiv [5]; one block (**212**), King offers wine to Re-Harakhti [= PETRIE, ii, pl. iv (101), cf. i, pl. xiv (5)], MONTET, *Les Nouvelles Fouilles* [&c.], pl. xxxii, cf. p. 74 (called 64 of PETRIE).

Block (**186**) with titles of Siamun, re-used later, from base of column, PETRIE, *op. cit.* ii, pl. viii [146], cf. pp. 12, 29; i, p. 17.

Blocks (**236**) of Siamun (one re-used later), *id. ib.* ii, pl. viii [145, 151], cf. pp. 12, 29.

Block (**226**) of Merneptah, re-used by Siamun, *id. ib.* pl. vii [138], cf. p. 29.

Fayence tablets of Psusennes I, in Cairo Mus., Brit. Mus., and Boston Mus., see *id. ib.* i, pp. 18 [top], 28 [34]; GAUTHIER, *Le Livre des Rois*, iii, p. 290 [vi] with note 3; one in Cairo Mus., MARIETTE, *Mon. Div.* pl. 103 [A]; *id. Album du Musée de Boulaq*, on pl. 37; see *id. Notice des principaux monuments* [&c.] (1864), p. 171 [412-15]. Another, in Petrie Collection, PETRIE, *A History of Egypt*, iii (1923), p. 222, fig. 89.

Found near Sanctuary.

Fragment (**183**) of red granite false door of Amenemhet I, *id. Tanis*, i, pl. iv [23], cf. p. 10; ii, p. 19.

Fragments (**197, 198, 208, 217**) of obelisk of King Nehesi , King's son, Dyn. XIII, in Cairo Mus., *id. ib.* i, pl. iii [19 A-E], cf. p. 8; ii, pp. 18-19, with 32, note 1; see NAVILLE, *Le Roi Nehasi* in *Rec. de Trav.* xv. 99; GAUTHIER, *op. cit.* ii. 54 [58, 1].

Upper part of red granite obelisk (**261**), Middle Kingdom, usurped by Ramesses II,

in Cairo Mus. 17022, PETRIE, op. cit. i, pls. ii [13], xi [61], cf. p. 7; ii, pp. 17, 24; KUENTZ, *Obélisques* (Cat. Caire), pl. xi [right], pp. 42-4 with fig. 43; King before Horus on fourth face, ENGELBACH, *The Direction of the Inscriptions on Obelisks* in *Ann. Serv.* xxix, p. 29, fig. 4, cf. pp. 27-8.

Upper part of small red granite obelisk (241) of Ramesses II, in Cairo Mus. 17020, KUENTZ, op. cit. pl. xi [left], pp. 37-8; second, first, and fourth faces, PETRIE, op. cit. i, pl. xi [62], cf. p. 26; ii, p. 24; see MASPERO, *Guide* (1914), p. 156 [575].

Granite fragments (177, 170), Ramesses II, possibly of obelisks, PETRIE, op. cit. ii, pl. iii [83-6], cf. p. 27.

Great granite stela (196) of Ramesses II, id. ib. pl. ii [78], cf. pp. 25-6, and i, pl. xiv [5] (in foreground), p. 18; text, DE ROUGÉ, *Inscr. Hiéro.* lxxviii-lxx.

Granite stela (164), double scene, Ramesses II with captives before Sêth and before Ptah, PETRIE, op. cit. ii, pl. iii [79], cf. pp. 9, 26; i, p. 18; MONTET, op. cit. pls. xxxiii, xxxiv, cf. pp. 74-5.

Granite stela (242, 243), and another fragment (202), both Ramesses II, PETRIE, op. cit. ii, pls. iii [81], ii [78 bis], cf. pp. 9, 26, 27; i, p. 18; text of stela, DE ROUGÉ, op. cit. lxxvii.

Other fragments (190, 194, 211, 214, 215) of stelae of Ramesses II, PETRIE, op. cit. ii, pls. ii [69-77], iii [82], cf. pp. 25, 27; i, p. 18.

Two inscribed pillars (244, 248-249) (not structural) of Ramesses II, id. ib. i, pl. xi [64 A-D, 65], cf. p. 18; ii, pp. 10, 24.

Granite blocks (238-240, 247), and fragments (206, 176) of inscribed columns, all of Ramesses II, id. ib. ii, pls. iv [87-93], v [105-8], cf. pp. 10, 27.

Fragment (175), Siamün, id. ib. ii, pl. viii [153], cf. p. 12.

Other granite fragments (180, 152), Middle Kingdom and Ramesses II, id. ib. i, pl. iv [22, 24], cf. p. 10; ii, pl. vi [122], cf. pp. 11, 19.

EASTERN OBELISKS. Ramesses II.

North obelisk (271); four faces, DE ROUGÉ, *Inscr. Hiéro.* ccxcvi [middle right]; second, third, and fourth faces, PETRIE, *Tanis*, i, pl. x [53], cf. p. 26; ii, p. 23; first face (not in PETRIE), L. D. iii. 142 d; NESTOR L'HÔTE MSS.* 20396, 358 [left]; lower part of first face, *Descr. de l'Égypte, Ant.* v, pl. 29 [12]; defaced hieroglyph of Sêth above cartouche at bottom, *Leçons de M. de Rougé* [&c.] in *Mélanges d'Archéologie*, ii. 290 [middle upper].

South obelisk (276); remains of four faces, PETRIE, op. cit. i, pl. x [54], cf. p. 26; ii, p. 23; part of one face (not in PETRIE), NESTOR L'HÔTE MSS.* 20396, 358 [right].

Found near Obelisks.

Fragment (279) of base of granite statue, Middle Kingdom, re-used in Dyn. XIX, PETRIE, op. cit. i, pl. ii [10 A, B], cf. pp. 6, 19; ii, p. 17.

Red granite bust (269) of Ramesses II; remains of cartouche, id. ib. i, pl. vi [42], cf. pp. 19, 25; ii, p. 21.

PTOLEMAIC HOUSE.

Unfinished kneeling statue holding offering-table, in Cairo Mus. 33314, CAPART, *L'Art Égyptien* (1911), pl. 188; EDGAR, *Sculptors' Studies and Unfinished Works* (Cat. Caire), pl. iv, cf. p. 5; see PETRIE, op. cit. i, p. 32 [41].

BRICK BUILDING.

See MONTET, *Les Fouilles de Tanis en 1931* in *Bull. . . Strasbourg*, x, p. 4; id. *Les Nouvelles Fouilles* [&c.], pp. 76-88 with figs. 5-8. Plan and views, id. ib. pls. xxxv-xxxviii.

Black granite fragment from sphinx or lion, id. ib. pl. xlv [3].

NORTH GATE.

Plan, id. ib. pl. xxxv.

Fragments of sandstone and granite colossi of Ramesses II, two red granite lions, and other fragments, see MONTET, *Une campagne de fouilles à Tanis* in *Bull. . . Strasbourg*, viii, pp. 2-3; id. op. cit. in ib. x, p. 3; id. *Les Nouvelles Fouilles* [&c.], pp. 41-5.

Other Remains from Temple.

Middle Kingdom.

Part of granite architrave of Sesostri III, PETRIE, op. cit. i, pl. ii [7], cf. p. 6; ii, p. 16; DE ROUGÉ, *Inscr. Hiéro.* lxxii [bottom].

Jamb (?) of Sesostri III; line of text, BURTON, *Excerpta Hiero.* xl [9].

So-called 'Hyksos' Monument.

Fragments of black granite sphinx of so-called 'Hyksos' style, in Cairo Mus. 530, EVERS, *Staat aus dem Stein*, i, pls. 124-5; head, BORCHARDT, *Statuen und Statuetten* (Cat. Caire), ii, pl. 89, cf. p. 83.

New Kingdom.

Statues of Ramesses II.

Red granite colossal statue, holding god-headed standards, with Prince Merneptah in relief on left side, in Cairo Mus. 575, id. ib. pl. 98, pp. 123-5; JÉQUIER, *L'Architecture*, ii, pl. 42 [right]; texts, PETRIE, op. cit. ii, pl. xi [172], cf. pp. 13, 31-2; texts of standards and Prince, MARIETTE, op. cit. in *Rec. de Trav.* ix. 13-14 [vi]; of Prince, DE ROUGÉ, *Inscr. Hiéro.* lxxiv [middle]; BRUGSCH, *An den Herausgeber in A.Z.* ix. 125 [lower left]; see MARIETTE, *Notice des principaux monuments* [&c.] (1864), p. 265 [15].

Grey granite seated statue usurped from Sesostri II, in Cairo Mus. 430, BORCHARDT, op. cit. ii, pl. 70, pp. 34-6; EVERS, op. cit. i, pls. 67, 68; texts, PETRIE, op. cit. ii, pl. xi [173], cf. pp. 13, 32; see MARIETTE, op. cit. in *Rec. de Trav.* ix. 13 [v].

Black granite seated statue usurped from Sesostri II, in Cairo Mus. 432, BORCHARDT, op. cit. ii, pl. 71, pp. 37-9; BRUGSCH and MASPERO, *La Trouvaille de Deir el-Bahari*, pl. 3 [middle]; EVERS, op. cit. i, pls. 65-6.

Grey granite seated statue, in Cairo Mus. 573, BORCHARDT, op. cit. ii, pl. 97, pp. 121-2; texts, PETRIE, op. cit. ii, pl. xi [174], cf. pp. 13, 32.

Upper part of black granite statue, in Cairo Mus. 616, DE ROUGÉ, *Album Photo.* 131; BORCHARDT, op. cit. ii, pl. 112, pp. 162-3; see MASPERO, *Guide* (1914), p. 177 [729].

Diorite seated statue, usurped from Middle Kingdom, in Louvre A. 20 (274 of Inventory of Drovetti Collection), RIFAUD, *Voyage*, 119 [lower left]; sides of throne, DEVÉRIA, *Lettre sur quelques monuments relatifs aux Hyq-s'os* in *Rev. Arch.* 2^o Sér. iv (1861), p. 250, reprinted in *Bibliothèque Ég.* iv. 210; see BOREUX, *Guide-Catalogue Sommaire* (1932), i, pp. 40-1.

Colossal black granite statue, name erased and replaced by names of Ramesses II, and of Merneptah round base, in Berlin Mus. 7264, RIFAUD, op. cit. 125 [2-4, 7-10]; *Aeg. und Vorderasien. Alterthümer*, pl. 1 [back left]; *Ausführ. Verzeichnis* (1899), p. 79, Abb. 13; EVERS, op. cit. i, pl. 64; texts, *Aeg. Inscr. Mus. Berlin*, ii. 13-17; back and part of base, BURTON, *Excerpta Hiero.* xl [8, 11]; cartouche of Ramesses and left side of base, BRUGSCH, *Tanis und Avaris in Zeitschr. d. Gesell. f. allg. Erdkunde*, Neue Folge xii (1862), pl. A [4], cf. p. 403; upper face of base by left foot, id. ib. pl. A [3], cf. p. 402.

Fragment of red sandstone colossus, PETRIE, op. cit. i, pl. vi [40], cf. p. 25; ii, p. 21; see (probably) MARIETTE, op. cit. in *Rec. de Trav.* ix. 13 [iv].

Various granite fragments (173, 159, 155, 144, 121, 139, 125, 112, 111, 108, 187),

PETRIE, op. cit. ii, pl. vi [119-21, 124-6, 128-32], cf. pp. 11, 28. (For positions, see id. ib. i, second plan at end.)

Other monuments.

Pair of red granite sphinxes, with cartouches of Ramesses II on chest and base, and of Merneptah on right shoulder, probably from the Avenue. Sphinx in Louvre A. 21, CAPART, *Rec. de Mon. Ég.* lix; texts, PETRIE, op. cit. i, pl. iv [25 A-D], cf. p. 10; ii, p. 19; SHARPE, *Eg. Inscr.* 2 Ser. 44 [lower]; see BOREUX, *Guide-Catalogue Sommaire* (1932), i, p. 39. Sphinx in Cairo Mus. 1120, EVERS, op. cit. i, pl. 137; ii, pl. i [30]; text on base, MARIETTE, op. cit. in *Rec. de Trav.* ix, pp. 11-12; id. *Notice des principaux monuments [&c.]* (1864), p. 262 [5].

Stela of Sety , Vizier, with Ramesses II offering to Syrian Sêth, and date of year 400 of Sêth-nubti, found and reburied by MARIETTE, and rediscovered by MONTET in 1933, MARIETTE, *La stèle de l'an 400* in *Rev. Arch.* 2^e Sér. xi (1865), pp. 169-85, pl. iv; Sêth, ROEDER, *Aegyptier und Hethiter* in *Der Alte Orient*, xx (1919), p. 63, Abb. 27, cf. p. 22; SETHE, *Der Denkstein mit dem Datum des Jahres 400 der Ära von Tanis* in *Ä.Z.* lxxv, pp. 85-9 with fig. (from MARIETTE); date of year 400 and cartouches of Sêth-nubti, BRUGSCH, *Thes.* 250 [1]; see MARIETTE, *Notice des principaux monuments [&c.]* (1864), p. 266 [17].

Stela of Pesiür , Vizier, temp. Sethos I-Ramesses II, in Antwerp, Musée Steen; text of both faces, CAPART, *Mélanges* in *Rec. de Trav.* xxii. 110 [3], 111 [top left]; see *Catalogue de la Collection d'Antiquités Égyptiennes* (1881), pp. 50-1.

Statues of Merneptah, RIFAUD, op. cit. 125 [1, 5-6, 11-16, 20-2].

Limestone block with fragment of historical text, Dyn. XVIII-XIX, in Cairo Mus., MÜLLER, *Egyptological Researches*, ii, p. 116, fig. 39.



Broken statue, apparently of Sekhmet; fragment of text, *Descr. de l'Égypte, Ant.* v, pl. 29 [15].

Similar statue of Sekhmet, temp. Ramesses II, in Cairo Mus.; titles of goddess, MARIETTE, op. cit. in *Rec. de Trav.* ix. 14 [vii].

After Dyn. XX.

Brick of Psusennes I, from Enclosure Wall, in Berlin Mus. 8062, L. D. iii. 255 d; *Aeg. Inscr. Mus. Berlin*, ii. 522; see PETRIE, op. cit. i, p. 19 [26].

Fayence tablet of Siamün, in Cairo Mus., MARIETTE, *Mon. Div.* pl. 103 [B]; see id. *Notice des principaux monuments [&c.]* (1864), p. 172 [418].

Small bronze cubes, Late Period, with names of Sekhemkarê, Queen Nebhôtep , and princesses, Dyn. XIII, and Princess Hēsnebtēs , Middle Kingdom, in Cairo Mus., MARIETTE, *Mon. Div.* pls. 103 [c], 104, cf. *Texte*, pp. 29, 30; DE ROUGÉ, *Inscr. Hiéro.* ccxcviii [upper]; see MARIETTE, *Notice des principaux monuments [&c.]* (1864), p. 174 [428]; GAUTHIER, *Le Livre des Rois*, ii. 4 [v], 5 [vii, ix, x], 130 [27].

Granite statue of Mer-ih , Commander-in-chief, Late Period, in Cairo Mus. 687; texts, BORCHARDT, *Statuen und Statuetten* (Cat. Caire), iii, pp. 30-1; DARESSY, *Statues de basse époque du Musée de Gizeh* in *Rec. de Trav.* xv. 150 [1].

Limestone block, Ptolemy IX Neos Philopator (?) before Isis and Horus, found in valley south of Enclosure Wall, PETRIE, *Tanis*, ii, pl. x [170], cf. p. 31; i, p. 32.

Ptolemaic fragments, id. ib. ii, pl. x [167-9], cf. pp. 12, 31.

SUBSIDIARY BUILDINGS

PTOLEMAIC CHAPEL, on north side of Approach to Great Temple. Ptolemy II Philadelphus and Arsinoë II.

Recess in west wall of shrine.

Stela, Ptolemy II and Arsinoë II before Min, Harsiesi, and Buto, in Brit. Mus. 1054, id. ib. i, pl. xv [3], cf. p. 31; ii, pl. x [164], cf. p. 30; *Guide*, Sculpture (1909), fig. on p. 257 [955].

Limestone sphinxes on either side; one, PETRIE, op. cit. i, pl. xv [4], cf. p. 31.

Found in front of shrine.

Limestone stelae of Ptolemy II and Arsinoë II; one, in Brit. Mus. 1056, id. ib. ii, pl. x [166], cf. pp. 30-1; *Guide to the Egyptian Collections* (1909), pl. xlvi opposite p. 269; (1930), p. 399, fig. 220; cartouches, *Guide*, Sculpture (1909), p. 256 [953].

Statuette of Ptolemy II (?), and small stelae (two of Apis-bull), PETRIE, op. cit. i, pl. xv [5], cf. p. 31.

TEMPLE OF ANTA. Ramesses II and Ptolemaic.

See MONTET, *Tanis, Avaris et Pi-Ramsès* in *Revue Biblique*, xxxix, p. 27; id. *Une campagne de fouilles à Tanis* in *Bull. de la Faculté des Lettres de Strasbourg*, viii, pp. 3-4; id. *Les Fouilles de Tanis en 1930* in ib. ix, pp. 4-7; id. *Les Fouilles de Tanis en 1931* in ib. x pp. 4-6; id. *Les Dieux de Ramsès-aimé-d'Amon à Tanis* in *Studies Presented to F. Ll. Griffith*, pp. 406-8; id. *Les Nouvelles Fouilles* [&c.], pp. 37-8, 89-134. Plan and section, id. ib. pl. xxxix, and p. 90, fig. 9. Views, id. ib. pls. xl, xli, lxviii, lxix.

Vestibule and Pylon. Ptolemaic.

Two blocks re-used in Pylon, one with princes, and one with cartouches of Ramesses II, id. ib. pl. lxxiii [1, 2], cf. pp. 118-19.

Red granite double-statue of Anta and Ramesses II, found before north wall of vestibule, now in Louvre, id. ib. pls. lxx-lxxii, cf. pp. 125-6.

Gilded plaster votive shield with warriors, Greek Period, found west of pylon, now in Alexandria Mus., id. ib. pls. lxxiv-lxxviii, cf. pp. 126-34, with figs. 20-9.

Court.

Remains of six granite palm-columns (one intact), Old Kingdom usurped by Ramesses II, some in Cairo Mus. and Louvre, MONTET, *Les Nouvelles Fouilles* [&c.], pls. xlv-xlvii [upper], xlvi-lviii, cf. pp. 95-107; id. op. cit. in *Studies Presented to F. Ll. Griffith*, pl. 65, pp. 407-8; one column, id. op. cit. in *Revue Biblique*, xxxix, pl. iv [1].

Blocks re-used in late wall, including reliefs of Ramesses II, Psusennes I, and Psammetikhos, id. *Les Nouvelles Fouilles* [&c.], pls. xli-xliii, cf. pp. 93-5.

Successive pavements of Ramesses II, Siamun re-used by Apries, and Late Period; re-used block of Merneptah and block of Apries, id. ib. pl. lxxiii [3, 4], cf. pp. 91-3.

Statues found in situ.

Grey granite seated double-statue of goddess Anta and Ramesses II, in Cairo Mus., id. op. cit. in *Revue Biblique*, xxxix, pl. iv [2-4]; id. *Les Nouvelles Fouilles* [&c.], pls. xlvii [lower left], liv, lv [right], cf. pp. 107-9; text of goddess, id. op. cit. in *Studies Presented to F. Ll. Griffith*, p. 408.

Red granite seated double-statue of Ramesses II and Sekhmet, id. *Les Nouvelles Fouilles* [&c.], pls. lv [left], lix, lx, cf. pp. 113-14; see id. op. cit. in *Bull. de la Faculté des Lettres de Strasbourg*, ix. 6-7, x. 5.

Three granite heads, royal bust, and bronze objects (all in Strasbourg Mus.), lion, and statuette of young prince (both in Cairo Mus.), and small stela, all found at feet of statue of Ramesses and Sekhmet, id. *Les Nouvelles Fouilles* [&c.], pls. lxi-lxiv [upper], lxv, cf. pp. 115-16.

Statues found near those in situ.

Headless sandstone double-statue of Ramesses II and Buto, id. ib. pl. lvi [1-3], cf. pp. 109-10.

Two broken statues of Ramesses III; one, id. op. cit. in *Revue Biblique*, xxxix, pl. iii [2]; id. *Les Nouvelles Fouilles* [&c.], pl. xlvi [lower right], cf. p. 109.

Headless black granite statue of Pikha'as, Governor of Tanis, Priest of youthful Khons, Ptolemaic, id. op. cit. in *Revue Biblique*, xxxix, pl. iii [1], cf. p. 14; id. *Les Nouvelles Fouilles* [&c.], pls. lvii, lviii, cf. pp. 110-12.

Fragments of black granite statue of man kneeling, Ptolemaic, id. ib. pl. lvi [4], cf. pp. 112-13.

Statues found farther south.

Lower part of black granite statue of Sebekhotp IV, id. ib. pl. lxvii [4], cf. p. 117.

Base and fragments of sandstone statue-group, Merneptah between Ptaḥ and goddess, id. ib. pl. lxvi, cf. p. 116.

Black granite fragments of statues of Sekhmet, and of squatting statue, id. ib. pls. lxvii [1-3], xliv [4], cf. pp. 116-17.

BUILDING OF PTOLEMY IV PHILOPATOR.

See MONTET, *Les Nouvelles Fouilles* [&c.], pp. 135-49. Plan, id. ib. pl. lxxix, cf. xxxix. Views, id. ib. pls. lxxx-lxxxii.

Reliefs of *heb-sed* festival, Old Kingdom, re-used in pavement, id. ib. pp. 142-3, figs. 32, 33, pl. lxxxiii.

Foundation-deposits with plaques of Ptolemy IV, in Cairo Mus. and Louvre, id. ib. pls. lxxxiv-lxxxvi, cf. pp. 145-9.

SOUTH GATE. Psusennes I.

See MONTET, *Les Nouvelles Fouilles* [&c.], pp. 155-7. Plan, id. ib. pl. lxxvii.

PRIVATE HOUSES, north-east of South Gate. Ptolemaic.

See id. ib. pp. 150-5, pl. lxxxix.



SOUTH TEMPLE.

See *Descr. de l'Égypte, Ant.* v, pl. 28 [t], and *Texte*, v, pp. 120-1, x, p. 499.

Leg of basalt statue with name of a Ptolemy, see MARIETTE, *Notice des principaux monuments du Musée à Boulaq* (1864), p. 260.

EAST TEMPLE.

Columns inscribed by Ramesses II and Osorkon II (?), in Cairo Mus., see id. ib. p. 259.

Fragment of limestone obelisk of 'A-seḥ-rē'  and his mother Per . . .  generally assigned to Hyksos Period or Middle Kingdom, found and reburied by MARIETTE, id. *Mon. Div.* pl. 103 [D], reproduced in PETRIE, *Tanis*, i, pl. iii [20], cf. p. 9; ii, p. 19; two sides, id. *A History of Egypt*, i (1923), p. 264, fig. 160; see MARIETTE, *Notice des principaux monuments* [&c.] (1864), p. 264 [10].

Headless black granite statue of Zeḥo , Overseer of prophets, Commander-in-chief, son of Wehebrē, holding figure of god, Late Period, in Cairo Mus. 689, BORCHARDT, *Statuen und Statuetten* (Cat. Caire), iii, pl. 126, pp. 32-4; texts, MARIETTE, *Mon. Div.* pl. 107 [1]; DARESSY, op. cit. in *Rec. de Trav.* xv. 151-4; long text on front, BRUGSCH, *Dict. Géog.* p. 303; see id. *Beiträge zu den Untersuchungen über Tanis* in *Ä.Z.* x. 16-19; MARIETTE, *Notice des principaux monuments* [&c.] (1864), p. 268 [24].

PRIVATE HOUSES, east of Great Temple.

Statue of Bakakhuu (properly read 'Ashōkhi) with demotic inscription, Roman, in Brit. Mus. 22750, PETRIE, *Tanis*, i, frontispiece [7], cf. p. 42; *Guide to the Third and Fourth Egyptian Rooms* (1904), p. 106 [right]; *Guide to the Fourth, Fifth, and Sixth Egyptian Rooms* (1922), p. 134 [right].

MISCELLANEOUS

(From Tanis, but exact provenance unknown.)

Three heads of Asiatic prisoners on base of statue (?), Middle Kingdom, in Cairo Mus. 396, BORCHARDT, op. cit. ii, pl. 65, cf. p. 14; EVERS, *Staat aus dem Stein*, ii, pl. vi [47] (incorrectly called Damanhūr), cf. pl. vii [50]; WERBROUCK, *Le Syrien Vaincu* in *Bull. des Musées Royaux . . . Bruxelles*, Nov. 1931, p. 154, fig. 2; see MASPERO, *Guide* (1914), p. 141 [498] (incorrectly called Damanhūr).

Bronze statuette, Psammetikhos I kneeling before Neith; texts, DANINOS-PACHA, *Notes sur les fouilles d'Aboukir* in *Rec. de Trav.* xii. 214.

Black granite statue of Zehō , Priest, Commander-in-chief, son of Unnūfer, holding small statues of Theban Triad, Late Period, in Cairo Mus. 700, BORCHARDT, op. cit. iii, pl. 129, pp. 42-3; texts, MARIETTE, *Mon. Div.* pl. 107 [2]; DARESSY, op. cit. in *Rec. de Trav.* xv. 154-6; horizontal text at top of back, BRUGSCH, *Dict. Géog.* p. 418; see id. op. cit. in *Ä.Z.* x. 16-19; MASPERO, *Guide* (1914), p. 241 [1086].

Limestone stela, Ptolemy II Philadelphus offering to Horus Smataui and Buto, and to Min and Arsinoë II, found apparently about three hundred metres south of south-west corner of Enclosure, now in Brit. Mus. 1057, PETRIE, op. cit. i, pl. xv [2], cf. pp. 31-2; ii, pl. x [165], cf. p. 30; *Guide to the Egyptian Collections* (1909), fig. on p. 269; see *Guide, Sculpture* (1909), p. 256 [954].



HURBEIT (PHARBAETHOS)



Description of ruins, NESTOR L'HÔTE MSS.* 20396, 36b.

Three stelae, Ramesses II offers to his own statue, in Hildesheim Mus. 377, 410, 1079, ROEDER, *Ramses II als Gott* in *Ä.Z.* lxi, pls. iv [3], v [3, 4], cf. pp. 59, 62, 63.

Stela of Mosi , Officer, with deceased and army receiving rings of gold from Ramesses II, in Hildesheim Mus. 374, IPPEL and ROEDER, *Die Denkmäler des Pelizaeus-Museums zu Hildesheim*, p. 96, Abb. 33; ROEDER, op. cit. p. 65, Abb. 2.

Stela with representation of Syrian god Reshef, in Hildesheim Mus. 1100, IPPEL and ROEDER, op. cit. p. 94, Abb. 32; ROEDER, op. cit. p. 62, Abb. 1.

Five stelae, in Hildesheim Mus. 1893, 1892, 411, 427, 397, including those of Nebamūn  before Osiris (No. 1893), Neferronpet , Doorkeeper, before Ptah (No. 1892), and a trumpeter, temp. Ramesses II (No. 397), id. ib. pls. iv [1, 2, 4], v [1, 2], cf. pp. 59, 60, 64.

Stela of Sety-nakht , and stela (unfinished) of Userhēt , Scribe of Amen-rē', temp. Ramesses II, in Brussels, Musées Royaux du Cinquantenaire, E. 3048, 3049; names, SPELEERS, *Rec. des Inscr. Ég.* 64 [265, 266].

Fragment of relief with head of Ramesses III, in Hildesheim Mus. 379, STEINDORFF, *Die Blaue Königskrone* in *Ä.Z.* liii, p. 71, Abb. 12.

Block from sarcophagus (?), Saite, in Cairo Mus., NAVILLE, *La plante de Horbéit* in *Ann. Serv.* x, pp. 191-2, with two plates; id. ib. xvi, plate opposite p. 190, cf. 187-90; see KEES, *Ein alter Götterhymnus als Begleittext zur Opfertafel* in *Ä.Z.* lvii. 92-120; NAVILLE, *La plante magique de Noferatoum* in *R.E.A.* i. 31-44.

Door-bolt from door of naos, in form of lion, with text of Apries, found in *sebakh*, now

in Cairo Mus., MARIETTE, *Mon. Div.* pl. 41 [upper]; BORCHARDT and REISNER, *Works of Art*, 48; PERROT and CHIPIEZ, *Hist. de l'Art*, i, p. 731, fig. 492; MASPERO, *L'Archéologie égyptienne* (1907), p. 303, fig. 297; id. *Guide* (1914), pp. 493-4 [4952] with fig. 117; MASPERO and ROEDER, *Führer* (1912), pl. 53; PILLET, *Le verrou* [&c.] in *Ann. Serv.* xxiv, p. 187, fig. 1, cf. pp. 191-2; STEINDORFF, *Die Kunst der Ägypter*, p. 310.

Offering-table dedicated to Osiris by unnamed king, Late Period, in Cairo Mus. 23078, KAMAL, *Tables d'Offrandes* (Cat. Caire), pl. xvii, pp. 64-6, cf. 208.

(For statue of Pbes, perhaps from here, see *infra* p. 39.)

EL-REBĀ'IVĪN

(Rebā of DARESSY.)

Lintel and jambs from tomb of Sen-rehui , Commander of troops, &c., Dyn. VI; text, DARESSY, *Notes et Remarques* in *Rec. de Trav.* xxiv. 163 [cxcvi].

ABŪ YĀSĪN

Sarcophagus of Pedesemtu , Commander of Greeks, Ptolemaic, in Cairo Mus.; texts, DARESSY, *Notes et Remarques* in *Rec. de Trav.* xx. 78-80 [clvii]; see KAMAL, *Notes sur quelques localités de la Basse-Égypte* in *Rec. de Trav.* xxviii. 25; MASPERO, *Guide* (1914), p. 3 [2].

Offering-table of Harkhebi , Ptolemaic, in Cairo Mus. 23141, KAMAL, *Tables d'Offrandes* (Cat. Caire), pl. xxxv, pp. 109-10; texts, id. op. cit. in *Rec. de Trav.* xxviii. 25-6.

ṬŪKH EL-QARĀMŪṢ

TEMPLE (destroyed).

See NAVILLE, *Mound of the Jew*, pp. 28-30, 53-6, cf. pls. xvii [1-21], xviii [upper]. Plan, id. ib. pl. ix [right].

Vase with cursive text, found near entrance to a chamber, now in Cairo Mus., id. ib. pl. viii [A], cf. pp. 30, 56; transcription, BISSING, *Miscellen* in *Ä.Z.* xxxvii. 87.

Foundation deposits; enamel plaque with cartouche of Philip Arrhidæus, NAVILLE, op. cit. pls. viii [B], xvii [8], cf. pp. 29, 55.

Treasure-chambers, in south-east part of Enclosure.

Plan of buildings, and description of hoard of gold and silver, Ptolemaic, EDGAR, *Report on an Excavation at Toukh el-Qaramous* in *Ann. Serv.* vii, pp. 206-9 with fig. 2; pectoral, bracelets, vases, &c., in Cairo Mus., id. in MASPERO, *Le Musée Égyptien*, ii, pls. xxii-xxviii; see MASPERO, *Guide* (1914), pp. 427-8 [O-R].

FINDS.

Stela, Sesonchis II before Amūn, Mut, and Khons, with text of gift of land, in Cairo Mus.; text, DARESSY, *Notes et Remarques* in *Rec. de Trav.* xx. 85 [clxiv].

Stela, King before Amūn and Mut, Ptolemaic; texts of divinities, id. ib. xxiv. 167 [cciv].

TELL BASTĀ (BUBASTIS) 

Description, NESTOR L'HÔTE MSS.* 20396, 359, 359 verso. View of ruins, EVERS, *Staat aus dem Stein*, i, pl. 118.

GREAT TEMPLE

NAVILLE, *Bubastis*, pp. 1-52, 55-9, pls. i-xlix; see id. *Les fouilles du Delta pendant l'hiver de 1887* in *Rec. de Trav.* x. 58-60. Plan, id. *Bubastis*, pl. liv.

daughters of Osorkon II, with their mother Kera'm' [= iv (1)], id. *Bubastis*, pl. xlii [c], cf. p. 52.

Inner thickness, id. *Festival-Hall*, pls. xxix [right], v-ix, xxvi [i, ii, iv, v], cf. xxxvi, and pp. 3-4, 17-23; part of festival text, id. *Bubastis*, pl. xlii [B], cf. p. 50.

Inner jamb, id. *Festival-Hall*, pls. xxxi [right], x-xiii, xxvi [iii], xxxvii, cf. pp. 23-5; texts of one block [= xi (6)], in Berlin Mus. 10837, *Aeg. Inschr. Mus. Berlin*, ii. 531-3.

North half.

Outer jamb, NAVILLE, *Festival-Hall*, pls. xxviii [right], xiv-xvii, xxxviii, cf. pp. 26-9; Osorkon II and Queen Kera'm' [= xvi (8)], in Brit. Mus. 1077, *Guide, Sculpture* (1909), fig. on p. 213 [770]; *Guide to the Egyptian Collections* (1930), p. 379, fig. 208.

Outer thickness, NAVILLE, *Festival-Hall*, pls. xxx [right], xviii, xxv [iii, iv, vi], cf. pp. 29-30.

Inner thickness, id. ib. pls. xxx [left], xix, xx, xxv [ii, v], xxvi [vi], cf. pp. 30-3.

Inner jamb, id. ib. pls. xxxi [left], xxi-xxiv, xxv [i], cf. pp. 33-5; goddess Bubastis, and priests performing ceremonies before Osorkon II in kiosk [= xxiii (5)], in Brit. Mus. 1105, *Guide, Sculpture* (1909), fig. on p. 212 [769].

Block, King adoring two divinities, with cartouche between, in Berlin Mus. 2099, *Aeg. und Vorderasiat. Alterthümer*, pl. 124; see *Ausführ. Verzeichnis* (1899), p. 246.

Various fragments, NAVILLE, *Festival-Hall*, pl. xxvii.

Heb-sed stela, year 22 of Osorkon II, probably from here, in private collection in New York, MARUCCHI, *Di una Stela Egizia* [&c.] in *Rendiconti Lincei* (1923), pl. ii, cf. pp. 77-88.

Re-used blocks of Pepy I, in Cairo Mus., NAVILLE, *Bubastis*, pl. xxxii [c, d], cf. pp. 5-6.

HYPOSTYLE.

Block from red granite jamb of Apophis II (?), found at east end, now in Brit. Mus. 1101, id. ib. pls. xxii [A], xxxv [c], cf. pp. 22-3; *Hiero. Texts* [&c.], Pt. v, pl. 18 [bottom left]; see *Guide, Sculpture* (1909), p. 97 [339]; GAUTHIER, *Le Livre des Rois*, ii. 142 [ii, c].

Lower part of black granite statue of Khyan, Dyn. XVI (?), usurped from Dyn. XII, found near last, now in Cairo Mus. 389, NAVILLE, op. cit. pls. xii, xxxv [A], cf. pp. 23-4; MASPERO, *Hist. Anc. des Peuples de l'Orient, Les Premières Mèlées*, fig. on p. 61; BORCHARDT, *Statuen und Statuetten* (Cat. Caïre), ii, pl. 62, pp. 7-8; PETRIE, *A History of Egypt*, i (1923), p. 253, fig. 150; MASPERO, *Guide* (1914), p. 149, fig. 46, cf. p. 148 [530].

Base of statue of Ramesses III, found at west end; text, NAVILLE, *Bubastis*, pl. xxxviii [c], cf. pp. 45-6.

Columns. Middle Kingdom, re-used.

Four large papyrus-columns (uninscribed), four Hathor-capitals of Osorkon II, four smaller palm-leaf columns of Ramesses II and Osorkon II, four additional Hathor-capitals of Osorkon II, all red granite; views, id. ib. pls. v-vii, cf. pp. 10-12; Hathor-capital, in Boston Mus., id. ib. pls. ix, xxiii [A]; Hathor-capital, in Louvre, id. ib. pl. xxiv [B]; JÉQUIER, *L'Architecture*, i, pl. 17 [4]; BÉNÉDITE, *La formation du Musée Égyptien au Louvre*, fig. on p. 277; see BOREUX, *Guide-Catalogue Sommaire* (1932), i, pp. 60-1; Hathor-capital, in Sydney, Australia, NAVILLE, op. cit. pl. xxiii [B]; Hathor-capital, in Brit. Mus. 1107, *Guide to the Egyptian Collections* (1909), pl. xlii opposite p. 254; (1930), p. 378, fig. 207; see *Guide, Sculpture* (1909), p. 212 [768]; Hathor-capital, usurped from Osorkon I, in Berlin Mus. 10834, *Aeg. und Vorderasiat. Alterthümer*, pl. 102; texts, *Aeg. Inschr. Mus. Berlin*, ii. 228, cf. *Ausführ. Verzeichnis* (1899), pp. 115, 116, with Abb. 23; palm-leaf column, in Brit. Mus. 1065, see *Guide, Sculpture* (1909), p. 164 [598].

Sculptures with dedication to goddess Bubastis by Osorkon II, under Hathor-capitals, NAVILLE, op. cit. pl. xli [A-C], cf. pp. 47, 48.

Granite column with inscription of Ramesses II and Osorkon II, probably from here, seen in field at El-Zaqâzîq, having been brought from Tell Basta by a European who wished to take it away, NESTOR L'HÔTE MSS.* 20396, 359 verso.

HALL. Nektanebos II (Nekht-ḥar-ḥebi).

Fragments of limestone seated statue of Merneptah with son Sety-Merneptah (afterwards Sethos II), on north side of entrance, now in Cairo Mus.; text, NAVILLE, *Bubastis*, pl. xxxviii [D], cf. p. 45.

Red granite block, scene of Amenophis II before Amen-rē' of Peru-nūfer, re-used by Sethos I, in Brit. Mus. 1103, id. ib. pls. xxvi [A], xxxv [D], cf. pp. 30-1, 56; see *Guide, Sculpture* (1909), p. 214 [773].

Granite fragments from walls, NAVILLE, op. cit. pls. xliv-xlvi, cf. pp. 57-8.

Fragment of cornice, *Descr. de l'Égypte, Ant.* v, pl. 29 [9], cf. *Texte*, x, p. 502; see NAVILLE, op. cit. p. 56.

Fragments of red granite naos of goddess Bubastis, in Cairo Mus. 70016, id. ib. pls. xlvii, xlviii, cf. pp. 56-7, 58; one block [= NAVILLE, xlvii (H)], ROEDER, *Naos* (Cat. Caire), pl. 12 [b], pp. 49-50, cf. pls. 55 [c, d], 77 [a], 84 [e], 87 [h]; see MASPERO, *Guide* (1914), p. 192 [802]. Block, in Brit. Mus. 1106, see *Guide, Sculpture* (1909), p. 248 [922].

Fragment of statue of Nektanebos II, NAVILLE, op. cit. pl. xliii [E], cf. p. 56.

Re-used block of Amenemḥet I, id. ib. pl. xxxiii [A], cf. pp. 8, 56.

OUTSIDE THE TEMPLE, on east side.

Triple group of Ramesses II with Ptaḥ and Rē' from ancient road near gateway; text, id. ib. p. 38 [top].

Colossal group of Ramesses II and Ptaḥ, near lateral door of First Hall, id. ib. pl. xix [right], cf. pp. 38, 42.

PORTICO NORTH OF TEMPLE. Osorkon II.

Fragments of sculptures, id. ib. pl. xli [E-H], cf. pp. 49-50.

FINDS.

Middle Kingdom.

Block with procession of Nile-gods, Sesostris I, id. ib. pl. xxxiv [D, E], cf. p. 8.

Architrave, Sesostris III re-used by Ramesses II, and blocks, in Brit. Mus. 1099, 1102, Sesostris III (one usurped by Ramesses II), id. ib. pls. xxvi [C], xxxiii [B-F], xxxiv [C], xxiv [A], cf. pp. 9, 14, 36; blocks, see *Guide, Sculpture* (1909), pp. 48-9 [166, 167].

Black granite statue, Dyn. XII, usurped by Ramesses II, head in Sydney Mus., Australia, base left on spot; base, NAVILLE, op. cit. pls. xxv [C], xxxviii [A], cf. pp. 9, 14, 37.

Fragment of block, Dyn. XII, id. ib. pl. xxxiv [B].

Head of colossal statue of unknown King, probably Dyn. XII, found near Temple, EVERS, *Staat aus dem Stein*, ii, pl. xii [62].

Architrave of Sekhem-khu-tau-rē'  Sekbekhotp II, in Brit. Mus. 1100, NAVILLE, op. cit. pl. xxxiii [G-I], cf. p. 15; *Hiero. Texts* [&c.], Pt. v, pl. 18 [top]; see *Guide, Sculpture* (1909), p. 82 [284]; GAUTHIER, *Le Livre des Rois*, ii, 15 [viii].

Red granite seated statue of Sekhem-waz-tau-rē'  Sekbekhotp III (?), in Brit. Mus. 871, BUDGE, *Egyptian Sculptures in the British Museum*, pl. xvi; *Guide to the Egyptian Collections* (1909), pl. xxvii after p. 222; (1930), p. 328, fig. 174; see *Guide, Sculpture* (1909), p. 80 [276]; GAUTHIER, op. cit. ii, p. 20 [ix] with note 5.

Statue, Dyn. XIII, usurped by Ramesses II, in Geneva, NAVILLE, op. cit. pl. xiv, cf. pp. 16, 37.

New Kingdom.

Fragment of text of Nubian campaign, probably Amenophis III (see BREASTED, *Anc. Rec.* ii, § 846), NAVILLE, op. cit. pl. xxxiv [A], cf. p. 10 (attributed to Sesostris III).

Black granite seated statue (headless) of Amenhotep , Vizier, temp. Amenophis III, in Brit. Mus. 1068, id. ib. pls. xiii [right], xxxv [E, E'], cf. pp. 32-3; see *Guide, Sculpture* (1909), p. 120 [428].

Similar statue of same man, in Cairo Mus. 590, NAVILLE, op. cit. pls. xiii [left], xxv [B], xxxv [F, F', F''], cf. pp. 31-2; BORCHARDT, *Statuen und Statuetten* (Cat. Caire), ii, pl. 106, pp. 145-6; titles, LEGRAIN, *Répertoire*, No. 255.

Double-statue, priest and priestess, temp. Amenophis III; text on back, NAVILLE, op. cit. pl. xxxv [G], cf. p. 33.

Base of small statue of Kherfu , Royal scribe, Steward, temp. Amenophis III, in Cairo Mus.; text, id. ib. pl. xxxv [H, H'], cf. p. 33.

Red granite block with cartouches of the Aten, temp. Amenophis IV, in Cairo Mus., id. ib. pl. xxxv [I], cf. p. 34.

Head of red granite statue of Ramesses II, in Cairo Mus. 636, id. ib. pl. xv, cf. pp. 35, 38; BORCHARDT, op. cit. ii, pl. 117, p. 185; see MASPERO, *Guide* (1914), p. 183 [760].

Headdress of colossal statue of Ramesses II, forming an anagram of his name, in Cairo Mus., NAVILLE, op. cit. pl. xxi [B, C], cf. pp. 34-5; see ERMAN, *Miscellen in Ä.Z.* xxix. 124-5.

Red granite blocks of Ramesses II, with name-rings of foreign peoples, in Brit. Mus., NAVILLE, op. cit. pls. xvii, xxxvi [B, D], cf. p. 40; one, in Brit. Mus. 1104, see *Guide, Sculpture* (1909), p. 162 [586].

Architraves and blocks of Ramesses II, some usurped, NAVILLE, op. cit. pls. xx, xxii [C], xxiii [D], xxvi [D], xxxvi [C, F-1], cf. pp. 36, 42.

Fragments of sculpture of Prince Merneptah offering to Shu and to Amen-re', fragment of text of Prince Kha'emwaset from colossal statue of Ramesses II, and text from black granite squatting statue of Prince Mentuirkhopshef (the last in Boston Mus.), id. ib. pls. xxxvi [K-M, O], xxxviii [C, C', C''], cf. pp. 42-3; name of Mentuirkhopshef, id. *Les fouilles du Delta* [&c.] in *Rec. de Trav.* x. 59.

Two broken black granite statues of 'royal sons of Kush', temp. Ramesses II, one in Boston Mus.; texts, id. *Bubastis*, pls. xxxvi [N], xxxviii [E], cf. pp. 42, 44-5.

Broken statue of Ptah, temp. Ramesses II; text, id. ib. pl. xxxviii [F], cf. p. 44.

Block from lintel, Dyn. XIX; remains of text, DARESSY, *Notes et Remarques in Rec. de Trav.* xxiv. 164-5 [CC].

Dyn. XX and later.

Lower part of black granite statue of Ramesses VI, left on site, NAVILLE, *Bubastis*, pls. xxv [A], xxxviii [I, I'], cf. p. 46.

Small red limestone statue of Ramesses VI, in Cairo Mus.; texts, id. ib. pl. xxxviii [H, H', H''], cf. p. 46.

Upper part of red granite statue of Ramesses VI, in Cairo Mus. 634, id. ib. pls. xvi, xxxviii [K], cf. p. 46; MASPERO, *Hist. Anc. des Peuples de l'Orient, Les Premières Mêlées*, fig. on p. 483; BORCHARDT, *Statuen und Statuetten* (Cat. Caire), ii, pl. 117, p. 184; PETRIE, *A History of Egypt*, iii (1923), p. 173, fig. 72; see MASPERO, *Guide* (1914), p. 176 [726].

Limestone fragment with cartouches of Sesonchis I; cartouches, NAVILLE, op. cit. p. 46.



Pedestal, Osorkon I; text, id. ib. pl. xli [D].

Sculptures usurped by Osorkon II, id. ib. pl. xlii [D-H], cf. p. 49.

Shoulder of colossus usurped by Osorkon II, id. ib. pl. xxiii [C], cf. p. 35.

Granite naos of goddess Bubastis, dedicated by Osorkon II, found about sixty metres east of Temple, in Cairo Mus. 70006; text, ROEDER, *Naos* (Cat. Caire), pp. 24-5; of one side, DARESSY, *Notes et Remarques in Rec. de Trav.* xxiii. 132 [clxxxiii].

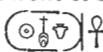
Stela of Espho'an , Priest, Dyn. XXII, probably from here, in Berlin Mus. 8441; texts, *Aeg. Inschr. Mus. Berlin*, ii. 204, cf. *Ausführ. Verzeichnis* (1899), p. 234.

Limestone double-statue of priest and priestess (in Brit. Mus.) and fragment of black granite statue, both Saite, and front of basalt crouching statue of Es-Harpkhrad , good name Neferebrē'-ankh |, Chancellor of the King of Lower Egypt, temp. Apries, (the last in Cairo Mus.); texts, NAVILLE, *Bubastis*, pl. xliii [A, A', C, D], cf. pp. 55-6.

Canopic vase of Aba , Divine father, Scribe of the treasury, Saite, found in *sebakh*; text, id. ib. pl. xlix [B], cf. pp. 58-9.

Fragment of small statue dedicated by Achoris, in Brit. Mus.; text, id. ib. pl. xliii [B], cf. p. 56.

Fragments of statues of Nektanebos II (Nekht-ḥar-ḥebi), and of Bubastis (same period); texts, id. ib. pl. xliii [F, G], cf. p. 58.

SMALL TEMPLE. Ramesses II and Osorkon I.

About half a kilometre from Great Temple.

See NAVILLE, *Bubastis*, pp. 60-2.

Fragments of offering-scenes of Osorkon I from walls, id. ib. pl. 1.

Fragments of record of temple-gifts of Osorkon I engraved on red granite pillar, in Cairo Mus., id. ib. pls. li-lii; see BREASTED, *Anc. Rec.* iv, § 729.

TOMB

HORI , Viceroy of Kush¹. Temp. Ramesses IV. 220 metres south-east of Coptic Cemetery.



Sarcophagus, in Cairo Mus., GAUTHIER, *Un vice-roi d'Éthiopie enseveli à Bubastis in Ann. Serv.* xxviii, pls. i, ii [1], cf. pp. 129-33 with fig. 1.

One ushabti, probably of same man and perhaps from here, in Cairo Mus., id. ib. p. 133, fig. 2.

MISCELLANEOUS

(From Tell Basta or from El-Zaqâziq, but exact provenance unknown.)

Statues.

Granite statuette of Kep (?) , good name Iri , holding square tablet, Dyn. XIII, in Brit. Mus. 1229, BUDGE, *Egyptian Sculptures in the British Museum*, pl. xv; *Guide to the Egyptian Collections* (1930), p. 329, fig. 175; HALL, *Two Middle Kingdom Statues in the British Museum in J.E.A.* xvi, pl. xxvii, pp. 167, 168 with fig. 1; text on tablet, *Hiero. Texts* [&c.], Pt. v, pl. 13 [left].

Statue of Neb-wa' , Chief prophet of Amen-rē' of the island (?) (Paknamunis), temp. Ḥaremḥab, stated to be from El-Zaqâziq, in Cairo Mus.; titles, LEGRAIN, *Répertoire*, No. 326.

Statue of Uzaḥori, , Priest of Harpocrates, Dyn. XX or XXI, from a tomb, now in Brit. Mus. 1187, BUDGE, op. cit. pl. xlii; id. *By Nile and Tigris*, i, plate opposite p. 148.

¹ Viceroy No. 18 of REISNER, see id. in *J.E.A.* vi. 50.

Bronze statuette of Tekûshe , Dyn. XXII, in Athens Mus., MASPERO, *Lettre à M. François Lenormant sur une statuette égyptienne in Gazette Archéologique* (1883), pp. 185-91 with two plates, reprinted in *Bibliothèque Ég.* viii. 259-66, pls. i, ii; id. *L'Archéologie égyptienne* (1907), p. 299, fig. 294; BISSING, *Denkmäler*, 59, and *Text* to 59 [fig.]; WEIGALL, *Anc. Eg. Works of Art*, 311.

Inlaid bronze fragment of base of statue of Sheshonk, 'great chief' (afterwards King Sesonchis I), Dyn. XXII, in Cairo Mus.; texts, MASPERO, *Notes sur quelques points de grammaire et d'histoire in A.Z.* xxii. 93 [1x].

Fragment of black granite statue-group of Horus, Osiris, and Isis, with name of Zeubastef'onkh, Prophet of Bubastis, in Cairo Mus. 39217, DARESSY, *Statues de Divinités* (Cat. Caire), pl. lvii, and pp. 302-3.



Headless basalt statue of 'Ankh-pef-hri , Priest, Saite, in Cairo Mus.; texts, id. *Quelques inscriptions provenant de Bubastis in Ann. Serv.* xi. 186-7 [i].

Fayence statuette of Horus as composite divinity, Dyn. XXVI or later, in Cairo Mus.; texts, id. ib. 191-2 [iii].

Torso of statuette of 'Ankh-hap , Chancellor of the King of Lower Egypt, holding naos, with magical text, temp. Nektanebos II (Nekht-har-hebi), in Cairo Mus.; texts, id. ib. 187-91 [ii].

Fragment of statue of Ptolemy II Philadelphus, probably from here, in Rome, Villa Albani; text, SETHE, *Urk.* ii. 70 (15).

Stelae.

Two limestone stelae, Tenro (Dor) , Mayor, and Kha'ptah , New Kingdom, in Cairo Mus.; texts, DARESSY, *Deux stèles de Bubastis in Ann. Serv.* xx. 122.

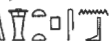
Stela of Deubaste-ponb , temp. Sesonchis IV, probably from here, in Cairo Mus.; text, id. *Trois stèles de la période Bubastite in Ann. Serv.* xv. 144.

Stela of Harkhebi, *knty* of the goddess Bubastis, year 23 (?) of Takelothis I or Takelothis III, in Florence Mus. 7207; texts, SCHIAPARELLI, *Museo Archeologico di Firenze*, pp. 516-17 [1806]; DARESSY, *Note additionnelle in Rec. de Trav.* xv. 175 [middle]; see GAUTHIER, *Le Livre des Rois*, iii, p. 390 note 1.

Stela, gift of land, temp. Pemü (?), Dyn. XXII, in Cairo Mus.; text, DARESSY, op. cit. in *Ann. Serv.* xv. 146.

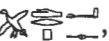
Stela with foundation-text of temple of Harmerty, year 51 of Psammetikhos I, dedicated by Pederpos , in Berlin Mus. 8438, BRUGSCH, *Thes.* 797 [103]; text, REVILLOUT, *Acte de fondation d'une chapelle à Hor-Merti [&c.] in Rev. Ég.* ii. 32-3; PIEHL, *Saitica in A.Z.* xxxi. 84; part, BRUGSCH, *Berichtigungen und Zusätze in A.Z.* ix. 60 [2]; see *Ausführ. Verzeichnis* (1899), p. 254; GAUTHIER, *Le Livre des Rois*, iv, p. 73 [xxix] with note 3.

Stela, gift of land, year 2 of Psammetikhos II, in Cairo Mus.; texts, DARESSY, op. cit. in *Ann. Serv.* xi. 192 [iv].

Small stela, year 3 of Amasis, in Cairo Mus.; text, MASPERO, *Notes sur quelques points de Grammaire et d'Histoire in A.Z.* xxiii. 11 [lxxiv].

Stela with foundation-text of a temple of Bubastis, year 32 (or 34) of Amasis, in Berlin Mus. 8439; text, REVILLOUT, *Acte de fondation d'une chapelle à Bast [&c.] in Rev. Égypt.* ii. 43; part, BRUGSCH, op. cit. in *A.Z.* ix. 60 [3]; see *Ausführ. Verzeichnis* (1899), p. 255; GAUTHIER, op. cit. iv, p. 119 [xxiii] with note 1.

Stela naming four kings of Dyn. XVIII, Roman Period (Hadrian ?), found at Tell Basta and bought in 1881, in Cairo Mus. 22200, KAMAL, *Stèles Ptolémaïques et Romaines* (Cat. Caire), pl. lxx, pp. 195-6; MILNE, *A History of Egypt* (1898), p. 45, fig. 33; see MASPERO, *Guide* (1884), pp. 361-2.

Stela, Amūn and worshipper, RIFAUD, *Voyage*, 95 [left].



Various.

Vase of Ramesses II, KAMAL, *Notes prises aux cours des inspections in Ann. Serv.* ix, pl. i, p. 91 [viii]; cartouches, id. *Note additionnelle in Ann. Serv.* xi. 43.

Two jambs of Bay , Divine father, naming the royal *ka* of Ramesses III, found in *sebah* east of Coptic cemetery of El-Zaqāzīq; texts, GAUTHIER, *À travers la Basse-Égypte in Ann. Serv.* xxiii. 169-70.

Jamb from tomb of Pa . . . , Fan-bearer on the right of the King, New Kingdom, in Cairo Mus.; text, DARESSY, *Notes et Remarques in Rec. de Trav.* xiv. 28 [xxxix].

Pectoral, Osorkon IV and his mother Queen Tedubaste , in Louvre, VERNIER, *La Bijouterie et la Joaillerie Égyptiennes*, pl. xix [1]; PERROT and CHIPIEZ, *Hist. de l'Art*, p. 834, fig. 569; PIERRET, *Égide de Sekhet in Gazette Archéologique*, vi (1880), pp. 85-6; BOREUX, *Guide-Catalogue Sommaire* (1932), ii, pl. xlv [upper right], cf. p. 338; cartouches, HILTON-PRICE, *Notes on the Antiquities from Bubastis (Tel Basta) in Trans. S.B.A.* ix. 50; see GAUTHIER, *Le Livre des Rois*, iii. 399 [ii].

Four canopic jars of Ḥor , Prophet of Bubastis, son of Shedesneferterem , Dyn. XXII, formerly in Hilton-Price Collection; texts, *P.S.B.A.* v, plate between pp. 98-9; HILTON-PRICE, *A Catalogue of the Egyptian Antiquities [&c.]*, i, pp. 219-20 [2034-2051].

Block from temple-wall, a king before Thoth and Neḥem'awat, Dyn. XXII, in Florence Mus. 6396; texts, SCHIAPARELLI, *Museo Archeologico di Firenze*, p. 518 [1807].

Fayence tablet of Darius I (?), bought at Tell Basta, in Cairo Mus.; cartouche and titles, NAVILLE, *Bubastis*, p. 62.

Fragment of bas-relief, artisans at work, Saite, found in *sebah*, now in Cairo Mus., MASPERO, *Le Musée Égyptien*, ii, pl. xxxviii [bottom], cf. p. 83 [c].

Bas-relief with offering-bringers, Saite, in Cairo Mus., id. *ib.* pl. xxxii [bottom], cf. pp. 78-9.

Sculptor's trial-piece of head of Queen, Saite, in Copenhagen, Ny Carlsberg Mus. A.E.N. 1345, MOGENSEN, *La Collection égyptienne*, pl. lxxxiii [A 636], cf. p. 81; HILTON-PRICE, *op. cit.* i, p. 338 [2836].

Lower part of red granite obelisk of Nektanebos I (Nekht-neb-f), probably originally from Hurbeit, in Cairo Mus. 17031; texts, KUENTZ, *Obélisques* (Cat. Caire), pp. 62-3.

Naos of Arsenuphis and Bubastis dedicated by Nektanebos II (Nekht-ḥar-ḥebi), found in Cairo, now in Cairo Mus. 70013, ROEDER, *Naos* (Cat. Caire), pl. 13, pp. 44-5, cf. pl. 48 [a-c]; texts, DARESSY, *op. cit.* in *Rec. de Trav.* xiv. 29 [xliii]; see MASPERO, *Guide* (1914), p. 194 [820].

Granite trough of Neb-si , Steward of the temple of Amūn; texts, CHABÂN, *Monuments recueillis pendant mes inspections in Ann. Serv.* x. 30 [iii].

Hoards.

Two gold and silver hoards, temp. Ramesses II or Dyn. XXVI,¹ found close together in a railway cutting near Temple, a portion of the first find scattered, the remainder and the second find in Cairo Museum, EDGAR in MASPERO, *Le Musée Égyptien*, ii, pls. xliii-liv, cf. pp. 93-108; part, MASPERO, *Egyptian Art*, plates opposite pp. 156, 158, 160, 162, 164, 166, 168; id. *Guide* (1914), pp. 431-3, figs. 101-4; group of vases, in Cairo Mus., BORCHARDT and REISNER, *Works of Art*, 44; silver jug with gold goat-handle, inscribed for Temtoneb , Royal butler, late Dyn. XIX, No. 53262 [EDGAR, pl. xliii, pp. 98-9], VERNIER, *Bijoux et Orfèvreries* (Cat. Caire), pl. cv, and pp. 416-17; BOREUX,

¹ The earliest cartouche is of Ramesses II, but the style of some suggest about Dyn. XXVI.

Block of Amasis near his naos, NAVILLE, *op. cit.* pl. iii [D], cf. p. 17.

Fragment of text on another block, DARESSY, *À travers les noms du Delta* in *Ann. Serv.* xiii. 182.

Naos of Nektanebos II (Nekht-ḥar-ḥēbi), found in Roman house some distance from Temple, in Cairo Mus. 70022; texts, ROEDER, *Naos* (Cat. Caire), p. 100, cf. pl. 65 [b, c]; see GAUTHIER, *op. cit.* iv, p. 109 note 2.

Unfinished royal statue re-used for Caracalla, and base with Horus-name of Apries perhaps belonging to it, found near naos of Amasis, in Cairo Mus.; statue, NAVILLE, *op. cit.* in *Archaeological Report* (1892-3), p. 2; MILNE, *A History of Egypt* (1898), p. 72, fig. 63; text from base, NAVILLE, *Ahnas el Medīneh*, p. 18; see MASPERO, *Guide* (1914), p. 246 [2004].

(For naos of Apries, see Tell Baqlīya, *infra* p. 39.)

RAM-CEMETERY, in north-west corner of enclosure.

View showing sarcophagi, NAVILLE, *op. cit.* in *Archaeological Report* (1892-3), plate opposite p. 4.

Lid of sarcophagus, in Cairo Mus., MARIETTE, *Mon. Div.* pl. 46; see MASPERO, *op. cit.* p. 173 [704].

TOMBS, beneath brick houses.

Contents, ushabtis, amulets, &c., in Cairo Mus., see QUIBELL, *Note on a tomb found at Tell er Robā* in *Ann. Serv.* iii. 245-9.

TELL TIMAI (THMUIS)

(Also called Tell Ibn Salām.)

Great stela of Ptolemy II Philadelphus and Arsinoë II, in Cairo Mus. 22181, MARIETTE, *Mon. Div.* pls. 43-4, 45 [a, b]; BRUGSCH, *Thes.* 629-31, 739, 740, cf. 855-6, 1277; with two additional fragments found twenty-five years later and replaced in position, KAMAL, *Stèles Ptolémaïques et Romaines* (Cat. Caire), pls. liv, lv, pp. 159-68; complete texts, SETHE, *Urk.* ii. 28-54 (13); see BRUGSCH, *op. cit.* in *Ä.Z.* ix. 81-2, 83-4; MASPERO, *Guide* (1914), p. 203 [858].

Stela, Horus on the crocodiles, Ptolemaic, in Cairo Mus. 9429, DARESSY, *Textes et Dessins magiques* (Cat. Caire), pl. x, cf. pp. 36-7.

MISCELLANEOUS.

(From Timai el-Amdīd, but exact provenance unknown.)

Sarcophagus of Teti-ishtef , General, Old Kingdom, found in *sebakh* north-west of Tell el-Rub'; text, CHABÂN, *Monuments recueillis pendant mes inspections* in *Ann. Serv.* x. 28 [1].



Block (inscribed on both sides) of Esbanebedd (Esbendetis) , First prophet of Mendes, Great chief of the Meshwesh, Dyn. XXII-XXV, in Cairo Mus.; texts, DARESSY, *Inscriptions historiques mendésiennes* in *Rec. de Trav.* xxxv. 125-6.

Base of seated statue of Psammetikhos I, in Palermo Mus.; text, AUSTIN, *On a Fragmentary Inscription of Psametik I in the Museum of Palermo* in *Trans. S.B.A.* vi, plate opposite p. 287.

Statue of Pedesemtu  (destroyed) kneeling in front of Hathor-cow, Saite, in Cairo Mus. 676, MASPERO, *Egyptian Art*, plate opposite p. 114, cf. p. 116 (called Şaqqâra); BORCHARDT, *Statuen und Statuetten* (Cat. Caire), iii, pl. 124, p. 22.

Statue of Thiebendedemau  holding naos, Saite (?), in Cairo Mus. 730, *id. ib.* pl. 135, p. 64.

Pedestal of statue of Thiebendedemau , Saite, in Berlin Mus. 8171; texts, PIEHL, *Varia* in *Ä.Z.* xxv. 123 [xlvi]; see *Ausführ. Verzeichnis* (1899), p. 258.

Pedestals of two statues, Saite, in Stockholm, Musée National. (a) Semset , Chief songstress; texts, PIEHL, *Deux inscriptions de Mendès* in *Rec. de Trav.* iii. 27-9; name and title, LIEBLEIN, *Dict. de Noms*, i, p. 400, No. 1237. (b) Sa(n)user , Prophet of Mendes, Hat-mehit, the Great and Little Ennead, &c.; texts, PIEHL, *op. cit.* 30-1; BORCHARDT, *Ein Saitischer Statuensockel in Stockholm* in *Ä.Z.* xvii. 111-12; name and title, LIEBLEIN, *op. cit.* i, p. 375, No. 1154.

Pyramidal fragment from back of statue of 'Ankh-Harsiësi , Prophet, naming Mendes and Thoth, Saite, in Cairo Mus.; text, DARESSY, *Fragment mendésien* in *Ann. Serv.* xvi. 60.

Inscribed limestone block; fragment of text with geographical name, *id. Notes et Remarques* in *Rec. de Trav.* xxvi. 133 [ccxii].

Two blocks of Nephertit I, Dyn. XXIX, and undated block naming Nehem'awat and Thoth; texts, EDGAR, *Notes from my Inspectorate* in *Ann. Serv.* xiii. 278-9.

Statue of priest of Mendes, in Cairo Mus. 45275; text, DARESSY, *Statues de Mendès* in *Ann. Serv.* xvii. 22-3 [ii].



Black basalt headless statue of Tefnakht , holding naos, Persian or Ptolemaic, in Cairo Mus. 41307; texts, *id. ib.* 23-4 [iii].

Offering-table (uninscribed), in Cairo Mus. 23216, KAMAL, *Tables d'Offrandes* (Cat. Caire), pl. liv, cf. p. 149.

Hellenistic marble heads, EDGAR in MASPERO, *Le Musée Égyptien*, iii, pls. i-v, cf. pp. 1-13.

EL-SIMBILLAWEIN

Fragment of statue of an ambassador, Saite; text, FOUCART, *Notes prises dans le Delta* in *Rec. de Trav.* xvii. 100 [2].

Statue of Pedeamün , son of Pemū  and Imhōtep, Late Period, apparently from Mendes, in Cairo Mus. 44637; text, DARESSY, *op. cit.* in *Ann. Serv.* xvii. 21-2 [1].

MÎT GHARÎṬA

Three fragments of granite naos of sacred bull of Pharbaethos (Hurbeit), Ptolemaic, built into mosque; texts, KAMAL, *Fragments de monuments provenant du Delta* in *Ann. Serv.* v. 193-9.

TELL ṬAMBÛL

Blocks of Ramesses II, and fragments from Saite tomb, found in *sebkh*; texts, DARESSY, *A travers les koms du Delta* in *Ann. Serv.* xiii. 186.

TELL EL-MUQDÂM (LEONTOPOLIS)

See NAVILLE, *Ahnas el Medîneh*, pp. 27-31; NESTOR L'HÔTE MSS.* 20396, 370. Plan and section, RIFAUD, *Voyage*, 142.

Finds.

Lower part of colossus of Sesostris III, in Brit. Mus. 1145; texts, NAVILLE, *op. cit.* pl. iv [A]; *Hiero. Texts* [&c.], Pt. v, pls. 10, 11; see *Guide, Sculpture* (1909), p. 47 [163].

Lower part of statue of Sesostris III, usurped by Osorkon II, in Brit. Mus. 1146, NAVILLE, *op. cit.* pls. xii [C], iv [C 1-6]; see *Guide, Sculpture* (1909), pp. 47-8 [164].

Lower part of colossal statue, Middle Kingdom, usurped by King Neḥesi ,

Dyn. XIII, and by Merneptah, in Cairo Mus. 538, BORCHARDT, *Statuen und Statuetten* (Cat. Caire), ii, pl. 89, pp. 87-8; right side, back, and texts by feet, MARIETTE, *Mon. Div.* pl. 63 [c]; left side and back, RIFAUD, *Voyage*, 92 [2-4]; text from back, WILKINSON MSS.* xviii. 36 [middle left]; text by feet with cartouche of King Neḥesi, DEVÉRIA, *Note additionnelle in Lettre à M. Auguste Mariette sur quelques monuments relatifs aux Hyq-s'os* in *Rev. Arch.* 2^o Sér. iv (1861), 259, reprinted in *Bibliothèque Ég.* iv. 220; MARIETTE, *Lettre à M. Maury* in *Rev. Arch.* 2^o Sér. iii (1861), 337; NAVILLE, op. cit. pl. iv [B I, 2], cf. p. 28; EBERS, *Aegypten und die Bücher Mose's*, 202; see NAVILLE, *Un Roi de la XIV^e Dynastie* in *Trans. Int. Cong. Or.* London (1892), ii. 292; id. *Le Roi Neḥesi* in *Rec. de Trav.* xv. 97-101; GAUTHIER, *Le Livre des Rois*, ii, p. 55 [v] with note 3.

Statuette of Min , Overseer of sealers, temp. Tuthmosis III, from Huber Collection, probably in Cairo Mus.; text on apron, BRUGSCH, *Recueil*, viii [3]; SETHE, *Urk.* iv. 1029 (311).

Statue of Ramesses II; texts, KAMAL, *Rapport sur quelques localités de la Basse-Égypte* in *Ann. Serv.* vii. 238.

Fragment of double-statue of Helly (?)  and another (name erased), Dyn. XIX, probably from here, in Cairo Mus. 605, BORCHARDT, op. cit. ii, pl. 109, p. 155.

Jamb of Ramesses III, from private house in the locality, in Cairo Mus.; text, KAMAL, *Notes sur quelques localités* [&c.] in *Rec. de Trav.* xxviii. 25 [upper left]; part, DARESSY, *Bas-relief d'un écuyer de Ramsès III* in *Ann. Serv.* xx. 7.

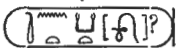
Door-hinge of Aupweth and Queen Tent-ket[wa]? , Dyn. XXII, probably from here, in Cairo Mus.; texts, DARESSY, *Le roi Auput et son domaine* in *Rec. de Trav.* xxx. 202, cf. 205; see GAUTHIER, op. cit. iii, p. 382 [iii, iv] with note 2.

Statue of Prince Nemareth , son of Sesonchis I, holding naos with statue of Onuris, in Cairo Mus.; texts, KAMAL, op. cit. in *Ann. Serv.* vii. 236-7.

Sarcophagus of Pedemihôs , Commander of troops; name and titles, MARIETTE, *Mon. Div.* pl. 63 [e]; BRUGSCH, *Dict. Géog.* 1026; WILKINSON MSS.* xiii. 64 [lower left].

Granite sarcophagus of Esmihôs , son of Pedemihôs, in Cairo Mus.; text, MARIETTE, op. cit. pl. 63 [d]; part, BRUGSCH, op. cit. 578, cf. 1026-7.

Squatting statue of 'Ankhpekhrad , Servant of Bubastis; texts, KAMAL, op. cit. in *Rec. de Trav.* xxviii. 24.

Statue of Pedusiri , Prophet of Yeb lord of Yebt-Hor, Late Period, in Huber Collection; text on back, BRUGSCH, *Recueil*, vii [2].

Stela with adoration of Rē'-Ḥarakhti; texts, GAUTHIER, *À travers la Basse-Égypte* in *Ann. Serv.* xxiii. 175.

Stela, King before lion and lion-headed god Mihôs, Late Period, evidently from here, in Hildesheim, Pelizaeus Mus., SPIEGELBERG, *Ein Denkstein aus Leontopolis* in *Rec. de Trav.* xxxvi, pl. viii, cf. pp. 175-6.

Four similar stelae with sacred lion, Ptolemaic, in Copenhagen, Ny Carlsberg Mus., Æ.I.N. 309-12, SCHMIDT, *Choix de Monuments Égyptiens* (1910), pls. xxxiii, figs. 84, 85, xxxv, figs. 90, 91; Nos. 310-12, MOGENSEN, *La Collection Égyptienne*, pl. cxiii [A 754-6], cf. p. 105.

Objects (mostly lions), found in 1884 and 1885, in Fouquet Collection, Cairo, *Collection du Docteur Fouquet* (Sale Catalogue), 1922, Nos. 99-122; CHASSINAT, *Les Antiquités égyptiennes de la Collection Fouquet*, pls. i-vii, cf. pp. 7-8; PERDRIZET, *Antiquités de Léontopolis* in *Monuments Piot*, vol. xxv, pls. xxiv, xxv, and pp. 349-85 with figs. 1-15; see *The Art of Ancient Egypt* (Burlington Fine Arts Club Exhibition, 1895), photo. xvi.

TOMB. Dyn. XXII (?). At west end of Tell el-Muqđâm, in cultivation.

Jewellery, including heart-scarab of Queen Mery-Mut Kera'm', wife of Takelothis II and mother of Osorkon III, and canopic jar of Pipu , GAUTHIER, *À travers la Basse-Égypte* in *Ann. Serv.* xxi, pl. i, cf. pp. 23-6.

Block of Osorkon II, found in north room; text, id. ib. p. 27.

MÎT YA'ÎSH

Stela of Osorkon II, in Cairo Mus.; text, DARESSY, *Une Stèle de Mit Yaich* in *Ann. Serv.* xxii. 77.

EL-BÛHA

Lower part of statue of Pbes , Overseer of Upper Egypt, temp. Psammetikhos I, bought at Tanis, probably from here or Hurbeit, in Cairo Mus. 922; texts, BORCHARDT, *Statuen und Statuetten* (Cat. Caire), iii, p. 156; LEGRAIN, *Notes d'inspection* in *Ann. Serv.* viii. 266-7; see DARESSY, *Notes et Remarques* in *Rec. de Trav.* xxiii. 126 [clxxx].

DUNDÎT

Fragments of blocks and colossi of Ramesses II, &c., originally from Tell el-Muqđâm; texts, EDGAR, *Report on the demolition of Tell Sheikh Nasreddin* in *Ann. Serv.* xiii. 123 [1-5].

Millstone with texts of Nektanebos II (Nekht-ḥar-ḥebi), probably from Tell Bašta; text, id. ib. 123 [bottom]-4.

CENTRAL PART

A. DAMIETTA BRANCH OF THE NILE. TELL BALALA TO ZIFTA

TELL BALALA (TELL 'TEBILLA') 

(South of Dikirnis.)

Block from temple, Sesonchis I or Takelothis II with Osiris; text, EDGAR, *Notes from my Inspectorate* in *Ann. Serv.* xiii. 277 [middle].

Seated statue of Osiri-nakht , Mayor in Mendes, Commander of troops, with prayer to Osiris-Onnophris and Isis of Rē-nufer, and the gods of Ḥat-khas, in Cairo Mus., CHABÂN, *Monuments recueillis pendant mes inspections* in *Ann. Serv.* x. 29 [ii], and plate; text on back, see EDGAR, op. cit. 277-8.

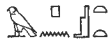
Granite squatting statue (headless) of Ḥarpaēsi , Priest, probably from here; names and titles, BRUGSCH, *Dict. Géog.* 1013; see DARESSY, *Recherches géographiques* in *Ann. Serv.* xxx. 81-2 [2].

TELL BAQLIYA (HERMOPOLIS PARVA) 

Capital of the XVth nome of Lower Egypt.

See NAVILLE, *Ahnas El Medineh*, pp. 22-6.

TELL EL-NAQÛS (northern mound).

Naos of Thoth, dedicated by Apries, in Cairo Mus. 70008, ROEDER, *Naos* (Cat. Caire), pls. 9, 10, 11a, pp. 29-36; texts, MASPERO, *Notes sur quelques points de grammaire et d'histoire* in *Ä.Z.* xxii. 90-3 [lix] (called in error Tell el Rub', cf. DARESSY, *À travers les koms du Delta* in *Ann. Serv.* xiii, p. 180 ncte); see MASPERO, *Guide* (1914), p. 188 [792].

Two small fragments of limestone mentioning the local Thoth, KAMAL, *Rapport sur quelques localités* [&c.] in *Ann. Serv.* vii. 233 [bottom].

MISCELLANEOUS

Headless statue of Nektanebos I (Nekht-neb-f), found on right bank of ancient canal, in Cairo Mus.; texts, id. ib. 233 [middle].

Block of Nektanebos I (Nekht-neb-f), used as threshold of sheikh's tomb, NAVILLE, op. cit. pl. iii [B], cf. p. 23.

Block of Psammetikhos I, built into wall of mill-pond, id. ib. pl. iii [c], cf. p. 26.

Fragment of basalt sarcophagus of Ahmosi , High priest of the local Thoth, Saite, found in mill, id. ib. pl. iii [A], cf. pp. 23, 25-6; texts, KAMAL, op. cit. in *Ann. Serv.* vii. 235-6.

Lower part of door-jamb, mentioning the local Thoth; text, NAVILLE, op. cit. p. 23.

NEAR TELL BAQLIYA

Black granite cynocephalus; title of Thoth on base, id. ib. p. 24.

BILGÂI

Stela of Ramesses II, in Cairo Mus., GARDINER, *The Stele of Bilgai* in *Ä.Z.* I, pl. iv, pp. 49-57.

BAHBÎT EL-HIGÂRA (ISEUM) 

Plan of site, *Descr. de l'Égypte*, *Ant.* v, pl. 30 [1]; DENON, *Voyage* (1802), pl. 17 [upper]; WILKINSON MSS.* xvii. J. 6.

TEMPLE OF ISIS. (Ruined.) Nektanebos II (Nekht-ḥar-ḥebi), Ptolemy II Philadelphus, and Ptolemy III Euergetes I.

Views of ruins, NAVILLE, *Détails relevés dans les ruines de quelques temples égyptiens*, pls. 2-4; EDGAR and ROEDER, *Der Isistempel von Behbêt* in *Rec. de Trav.* xxxv, p. 108, Abb. 1. Detail of capital of column, *Descr. de l'Égypte*, *Ant.* v, pl. 30 [2].

Blocks in the ruins.

Texts, ROEDER, *Der Isistempel von Behbêt* in *Ä.Z.* xvi. 63-70; EDGAR and ROEDER, op. cit. 91-114.

Nektanebos I (Nekht-neb-f).

Remains of scene, King offers linen, and a god from another scene, NAVILLE, op. cit. pl. 7 [B, C].

Nektanebos II (Nekht-ḥar-ḥebi).

Three scenes, King offers oil and linen to, and adores, gods, and scene of King offering four vases to a god [EDGAR and ROEDER, p. 91 (2, 3)], NAVILLE, op. cit. pls. 6 [A], 7 [A]; second scene, *L. D.* iii. 287 b, cf. *Text*, i, p. 220 δ. King [EDGAR and ROEDER, p. 92 (4)]; cartouches and fragment of text, PIEHL, *Le Temple de Behbêt-el-Hagar* in *Ä.Z.* xxvi. 110 [upper]. Remains of four divinities, temp. Nektanebos II (?), in Rome, Museo Nazionale, 52045, FARINA, *Monumenti Egizi in Italia in Ausonia*, ix (1914), pl. i; texts, id. *Minima in Sphinx*, xviii. 67-9.

Ptolemy II Philadelphus.

King offers milk to Nut, pectoral to Osiris-Onnophris, and collar to Osiris [EDGAR and ROEDER, p. 111 (103) with Abb. 6; ROEDER, p. 66 (8-10)], NAVILLE, op. cit. pl. 5 [A]; NESTOR L'HÔTE MSS.* 20396, 345; first two scenes, WILKINSON MSS.* xvii. H. 34

d [lower]. King offers ointment and linen to Osiris and Isis, and (destroyed) censers before Rē'-Harakhti [EDGAR and ROEDER, p. 113 (104) with Abb. 5; ROEDER, p. 67 (11-12)], NAVILLE, op. cit. pl. 5 [B]; NESTOR L'HÔTE MSS.* 20396, 346; WILKINSON MSS.* xvii. H. 34 d [upper]; first scene, L. D. iv. 8 b [upper], and *Text*, i, p. 220 γ; BURTON MSS.* 25634, 25 [left]. Fragments of black granite naos [parts, EDGAR and ROEDER, pp. 105 (71), 106 (79), 113 (106, 108); ROEDER, pp. 67-9 (13-15)], NAVILLE, op. cit. pls. 8-10; part of large side, King offers linen to Anubis [NAVILLE, 9 (D-G) called 8], WILKINSON MSS.* xvii. H. 36 verso [lower right]; part of small side, King offers sphinx ointment-jar to Osiris and Isis [NAVILLE, 10 (right)], L. D. iv. 8 b [lower], cf. *Text*, i, p. 220 [middle]; BURTON MSS.* 25634, 25 [right]; NESTOR L'HÔTE MSS.* 20396, 368 verso [top]. Fragments of red granite monument [parts, EDGAR and ROEDER, pp. 106-7 (77, 80, 83); ROEDER, p. 70 (20)], NAVILLE, op. cit. pls. 11-12 [A-1]; text naming goddess Mehit of Samannûd [NAVILLE, A], id. *Mound of the Jew*, pl. vi [bottom right], cf. p. 26. Fragments of red granite monument, possibly same as last [parts, EDGAR and ROEDER, pp. 105-6 (74, 80 a, 81); ROEDER, pp. 69-70 (18, 19)], NAVILLE, *Détails relevés* [&c.], pls. 13-14 [A-G]; King with linen before Isis [NAVILLE, A], WILKINSON MSS.* xvii. H. 36 [middle left]; text between them, NESTOR L'HÔTE MSS.* 20396, 368 verso [middle]. Fragment, King with sistra, NAVILLE, op. cit. pl. 12 [L]. Various granite fragments [EDGAR and ROEDER, pp. 105-7 (70, 75, 76, 83 a)], NAVILLE, op. cit. pl. 13 [v-z]. King offers to goddess [EDGAR and ROEDER, pp. 102-3 (56)], LUCAS, *Voyage* (1724), ii, first plate after p. 12 [top right]; part of text (probably), NESTOR L'HÔTE MSS.* 20396, 366 verso [top left]. Horizontal line of text and Nile-god below [EDGAR and ROEDER, p. 113 (113); ROEDER, p. 70 (21)], *Descr. de l'Égypte, Ant.* v, pl. 30 [4]; WILKINSON MSS.* xvii. H. 34 c [middle]; NESTOR L'HÔTE MSS.* 20396, 365 verso [right]; cartouches and Nile-god, MINUTOLI, *Reise zum Tempel des Jupiter Ammon*, xxix [2, 3]; horizontal text, SETHE, *Urk.* ii. 118-19 (25); part, L. D. *Text*, ii, p. 220 [middle left]. Goddess from scene of King offering field, and King with two vases before Nephthys [EDGAR and ROEDER, p. 97 (36)], NESTOR L'HÔTE MSS.* 20396, 368 [top]. King followed by *ka* offers necklace to Isis [EDGAR and ROEDER, p. 97 (37)], id. ib. 365 [middle]. King offers crowns to god, and symbols to Isis [ROEDER, p. 65 (6, 7)], since 1915 in Tanṭa (first in Mîdân Kitchener, now in Court of the Musée Municipal); texts, GAUTHIER, *À travers la Basse-Égypte* in *Ann. Serv.* xxiii. 69-70; block No. 7, LUCAS, op. cit. ii, second plate after p. 12 [top left] (inaccurate). Isis from destroyed scene, and King offering two bags to Isis [EDGAR and ROEDER, pp. 98-9 (42)], *Descr. de l'Égypte, Ant.* v, pl. 30 [3]. Cartouches of King and Isis [EDGAR and ROEDER, p. 100 (48)]; of Isis, PIEHL, op. cit. in *A.Z.* xxvi. 110 [lower]. Nile-god and horizontal text of Ptolemy II (?) [EDGAR and ROEDER, p. 99 (44)]; text, NESTOR L'HÔTE MSS.* 20396, 368 [bottom].

Ptolemy III Euergetes I.

Cornice of King and Berenice II with Hathor-heads, and King offering to Osiris [EDGAR and ROEDER, p. 107 (84-6) with Abb. 2; ROEDER, p. 70 (22, 23)], NAVILLE, op. cit. pl. 6 [B left]; sketch and texts from cornice, WILKINSON MSS.* xvii. H. 33 [upper]. Fragments of red granite columns [NAVILLE, D-F = EDGAR and ROEDER, pp. 114 (118), 109 (93, 92)], NAVILLE, op. cit. pl. 15 [A-F]; cartouches, L. D. *Text*, i, p. 220 [near bottom]. King censes before Isis-bark [EDGAR and ROEDER, p. 111 (101) with Abb. 3; ROEDER, pp. 64-5 (5)]; incomplete, LUCAS, op. cit. ii, first plate after p. 12 [left]; WILKINSON MSS.* xvii. H. 34 c [bottom]. Destroyed scene of King, NESTOR L'HÔTE MSS.* 20396, 365 verso [left]. King with censer before Isis, id. ib. 366.

Date unknown.

Remains of scene with Osiris and Isis [EDGAR and ROEDER, p. 113 (110); ROEDER,

p. 69 (17)], NAVILLE, op. cit. pl. 6 [B right]. Granite block with title of a Ptolemy [EDGAR and ROEDER, p. 105 (69)], NAVILLE, op. cit. p. 40, fig. 1. King offers *uzat* to god, and Sobk and Osiris (?) seated [EDGAR and ROEDER, pp. 93-4 (21, 16)], WILKINSON MSS.* xvii. H. 36 verso [left]. Ptolemy offers natron to two divinities [EDGAR and ROEDER, p. 94 (17)], WILKINSON MSS.* xvii. H. 36 [bottom left]; part of text behind King, L. D. *Text*, i, p. 220 [top left]. Seated goddess [EDGAR and ROEDER, p. 96 (31)], NESTOR L'HÔTE MSS.* 20396, 366 verso [middle right]. King led to Isis by Horus of Edfu and another god [EDGAR and ROEDER, p. 111 (99); ROEDER, pp. 63-4 (3)]; omitting latter, WILKINSON MSS.* xvii. H. 33 [lower]. Ptolemy before goddess, NESTOR L'HÔTE MSS.* 20396, 347. Ptolemy offers water to goddess, id. ib. 367. Other fragments, *Descr. de l'Égypte, Ant.* v, pl. 30 [5-9].

MISCELLANEOUS

Fragment from basalt sarcophagus (?) of Harsîsi, Vizier, temp. Nektanebos I (Nekht-neb-f), in Cairo Mus.; text, SPIEGELBERG, *Der Vesier Harsîsi zur Zeit des Nektaneb's* in *Ä.Z.* lxiv. 88; titles of divinities, BRUGSCH, *Dict. Géog.* 456.

Copper dove-tail of Nektanebos II (Nekht-ḥar-ḥebi), bought at Bahbît el-Ḥigâra in 1806, VALENTIA, *Voyages and Travels* [&c.] (1809), ii, pl. 23 [2], cf. iii, p. 438 (these plates are unnumbered and often misplaced by binders).

BÂNÛB

Three blocks, one of Nektanebos II, and one of Ptolemy II Philadelphus, probably originally from Temple of Bahbît; texts, EDGAR and ROEDER, *Der Isistempel von Behbêt* in *Rec. de Trav.* xxxv. 114-15.

Granite statue-base of Ptolemy III Euergetes I, in Cairo Mus.; text, CHABÂN, *Monuments recueillis pendant mes inspections* in *Ann. Serv.* x. 30 [iv] (stated to be from 'Talklia [Talkhâ?], but see EDGAR and ROEDER, op. cit. p. 114, note 1).

EL-MAḤALLA EL-KUBRA

Red granite fragment with cartouches of Psammetikhos II, built into cistern; text, DARESSY, *Notes et Remarques* in *Rec. de Trav.* xxiii. 126 [clxxix]; KAMAL, *Notes sur quelques localités* [&c.] in *Ann. Serv.* vii. 238 [near bottom]; id. *Rapport sur une inspection faite à Tell el-Waga* in *Ann. Serv.* viii. 2.

Black granite block with cartouche of Tshenêsi , mother (?) of Amasis, built into a house, or as lintel in mosque (according to NESTOR L'HÔTE); text, DARESSY, *Notes et Remarques* in *Rec. de Trav.* xxii. 142-3 [clxxv]; NESTOR L'HÔTE MSS.* 20396, 364 [3]; see GAUTHIER, *Le Livre des Rois*, iv, p. 128 [lxxi], with note 2.

Block of Apries, used as threshold, NESTOR L'HÔTE MSS.* 20396, 364 [5].

Part of obelisk (?), used as lintel in mosque, id. ib. 364 [6].

Torso of Shedsumesu , temp. Nektanebos I (Nekt-neb-f), found at Duqmeira, probably from here, in Cairo Mus.; texts, GAUTHIER, *À travers la Basse-Égypte* in *Ann. Serv.* xxiii. 174.

Fragment of base of colossal black granite hawk of Nektanebos II (Nekht-ḥar-ḥebi); text, NESTOR L'HÔTE MSS.* 20396, 364 [2].

Two blocks, scene before god, and fragment of text, used as thresholds, id. ib. 364 [1, 4].

Granite block, used as millstone; fragment of text, KAMAL, op. cit. in *Ann. Serv.* vii. 238 [bottom]; id. op. cit. in *Ann. Serv.* viii. 1.

Granite shrine in mosque, and two uninscribed sarcophagi, *Descr. de l'Égypte, Ant.* v, pl. 30 [10-14], cf. *Texte*, v, pp. 167-9; see NESTOR L'HÔTE MSS.* 20396, 364.

Black granite seated statue, wrapped in cloak, of Khentekhtaihotp , Overseer of prophets, in Cairo Mus., KAMAL, *Rapport sur une statue recueillie à Kom el-Shataîn* [&c.] in *Ann. Serv.* ii, first plate after p. 192, cf. pp. 126-7.

SAMANNÛD (SEBENNYTOS)

TEMPLE OF ONURIS-SHU. Rebuilt by Nektanebos II (Nekht-ḥar-ḥebi).

Upper part of green diorite naos, Nektanebos II (Nekht-ḥar-ḥebi) offers wine to Shu, Bubastis, and Onuris, in Cairo Mus. 70015, NAVILLE, *Détails relevés dans les ruines de quelques temples égyptiens*, pl. 17 [A 1, 2]; texts, ROEDER, *Naos* (Cat. Caire), pp. 47-8, cf. pl. 63 [c, d].

Blocks.

Granite blocks of Nektanebos II (Nekht-ḥar-ḥebi), one with Nile-god, NAVILLE, *Mound of the Jew*, pl. vi [A 1, 2, 3], cf. p. 25; texts, KAMAL, *Sébennytos et son temple* in *Ann. Serv.* vii. 89 [i, ii]; fragment with offering-bringer, built into mosque, NESTOR L'HÔTE MSS.* 20396, 362 verso [upper].

Two fragments of cornice with cartouches of Philip Arrhidaeus; cartouches, EDGAR, *Notes from the Delta* in *Ann. Serv.* xi. 91 [1, 2].

Red granite fragment, Alexander II; text, KAMAL, op. cit. 90 [1].

Black granite fragment, Alexander II offers food to Onuris, in street in front of mosque in time of NESTOR L'HÔTE, WILKINSON MSS.* xvii. H. 34 a [left]; NESTOR L'HÔTE MSS.* 20396, 362 verso [lower]; texts, L. D. *Text*, i, p. 221 [top] with α; KAMAL, op. cit. 90-1 [ii]; cartouche, NAVILLE, op. cit. pl. vi [D], cf. p. 26.

Granite block in two pieces, Alexander II offers sphinx to Onuris-Shu, and lion-headed goddess from another scene; texts, EDGAR, op. cit. in *Ann. Serv.* xi. 92 [3, 4].

Granite block, Alexander II with standard behind him; texts, id. ib. 94 [9].

Block, Alexander II, with name of Onuris-Shu; text, NAVILLE, op. cit. pl. vi [c].

Granite block with cartouche of Alexander II, seen in street in village, NESTOR L'HÔTE MSS.* 20396, 363 [right].

Block with head of Ptolemy II Philadelphus and standard, NAVILLE, op. cit. pl. vi [E], cf. p. 27; part, id. *Détails relevés dans les ruines de quelques temples égyptiens*, pl. 17 [B].

Red granite blocks of Ptolemy II Philadelphus, one with scene of King offering wine, id. ib. pl. 16 [A 1-4]; texts, KAMAL, op. cit. in *Ann. Serv.* vii. 92 [iii]-93 [iv].

Granite fragment with part of hymn to rising sun, and on other side man offering natron, Ptolemaic, built into house in village in time of NESTOR L'HÔTE, NAVILLE, op. cit. pl. 16 [B 1, 2]; hymn, id. *Mound of the Jew*, pl. vi [B], cf. p. 27; KAMAL, op. cit. 91 [i]; WILKINSON MSS.* xvii. H. 34 a [right]; NESTOR L'HÔTE MSS.* 20396, 363 [left]; beginning, L. D. *Text*, i, p. 221 [middle left].

Similar red granite block; text, KAMAL, op. cit. 91 [ii].



Blocks without royal names, EDGAR, op. cit. in *Ann. Serv.* xi. 92-5 [5-8, 10-13].

Two fragments, one (Ptolemaic) with name of Onuris-Shu, NAVILLE, *Détails relevés* [&c.], pl. 17 [c, d].

FINDS. (From Samannûd, but exact provenance unknown.)

Offering-table of Amenemḥet VI (?), Dyn. XIII, in Alexandria Mus.; texts, DARESSY, *Inscriptions hiéroglyphiques du Musée d'Alexandrie* in *Ann. Serv.* v. 124 [xxxiv]; see BRECCIA, *Alexandrea ad Aegyptum* (1922), pp. 154-5; GAUTHIER, *Le Livre des Rois*, ii, pp. 6-7 [4], with note 1 on p. 7.

Black granite seated statue (headless) of Osiris with figures of Isis and Nephthys on sides, dedicated by Akanush , Prophet of Onuris, temp. Weḥibrē' (probably Psammetikhos I or Apries), in Cairo Mus. 657; texts, NAVILLE, *Mound of the Jew*, pl. v, cf. pp. 24-5; DARESSY, *Notes et Remarques* in *Rec. de Trav.* xvi. 126 [cxii]; BORCHARDT, *Statuen und Statuetten* (Cat. Caire), iii, pp. 3-4; see NAVILLE, *Les Fouilles du Delta pendant l'hiver de 1887* in *Rec. de Trav.* x. 57; GAUTHIER, *Le Livre des Rois*, iii, p. 413 [iii], with note 2.

Grey granite sarcophagi of Shbemmin  and his son 'Ankh-Ḥor , Prophets of Onuris, Persian Period, in Cairo Mus., ABOU-SEIF, *Two granite sarcophagi from Samannūd (Lower Egypt)* in *Ann. Serv.* xxiv, plate at end, cf. pp. 91-6; three divinities from interior of coffin of 'Ankh-Ḥor, ENGELBACH, *Evidence for the use of a Mason's Pick in Ancient Egypt* in *Ann. Serv.* xxix, pl. 2, cf. p. 23.

Black granite torso of Nektanebos I (Nekht-neb-f), in Paris, Bibliothèque Nationale, *Descr. de l'Égypte, Ant.* v, pl. 69 [7, 8], cf. *Texte*, x, pp. 572-3; see NAVILLE, *Mound of the Jew*, p. 27.

Another torso of same King; text on girdle, EDGAR, *Notes from the Delta* in *Ann. Serv.* xi. 96.

Fragment of offering-table, NESTOR L'HÔTE MSS.* 20396, 362 [bottom].

Naos of Onuris dedicated by Nektanebos II (Nekht-ḥar-ḥebi), found in a hospital in Cairo, possibly from here, now in Cairo Mus. 70012, ROEDER, *Naos* (Cat. Caire), pl. 14 (called 70015), pp. 42-3, cf. pl. 47 [b-e]; see MASPERO, *Guide* (1914), pp. 195-6 [826].

ABÛ ŞÎR (BUSIRIS)

See NAVILLE, *Mound of the Jew*, pp. 27-8; id. op. cit. in *Rec. de Trav.* x. 57-8.

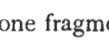
Limestone fragment with name of Sheshonk , Dyn. XXII, id. *Mound of the Jew*, pl. vii [c], cf. p. 28.

Part of green basalt statue of Weḥibrē' . . . , Overseer of Sealers, Saite, in Cairo Mus., id. ib. pl. vii [B], cf. p. 28.

Granite block, goddess Menkhetheb with cartouches of Darius I, in Brit. Mus., id. ib. pl. vii [A], cf. p. 27.

ZIFTA

Black granite fragment with dedication to Monthu, perhaps from Tell Baṣṭa; text, EDGAR, *Report on the demolition of Tell Sheikh Nasreddin* in *Ann. Serv.* xiii. 124.

TELL UMM ḤARB OR TELL MUŞṬÂI (KÔM EL-MUSTEIN)

TEMPLE OF THOTH.

Blocks of Ramesses II, Merneptah, Ramesses III, and (chiefly) Sesonchis II, EDGAR, *Report on an excavation at Tell Om Harb* in *Ann. Serv.* xi, pp. 165-9, and one plate; see DARESSY, *À travers les koms du Delta* in *Ann. Serv.* xii. 209-13.

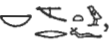
Two small statue-groups, one of slate and the other of alabaster, Nebmertef , Scribe of the archives of the Lord of the Two Lands, Lector, at feet of Thoth as baboon on altar, Dyn. XIX, in Louvre, BÉNÉDITE, *Scribe et babouin* [&c.] in *Mon. Piot.* xix, pls. i, ii, pp. 6-17, with figs. 1-4; BOREUX, *Guide-Catalogue Sommaire*, ii (1932), pl. lxiv, cf. pp. 474-5; see DARESSY, op. cit. 212.

Squatting ape with hollow body containing mummies and statuettes of apes, in Cairo Mus. 29751, GAILLARD and DARESSY, *La Faune Momifiée* (Cat. Caire), pl. 1, cf. p. 124; MASPERO, *Guide* (1914), p. 182, on fig. 53, cf. p. 181 [755]; see EDGAR, op. cit. p. 164.

B. BETWEEN DAMIETTA AND ROSETTA BRANCHES
OF THE NILE

MAŠARA

Part of sarcophagus of Queen Uza-shu , King's mother, Saite, found at 'Kôm Yetwal wa Yeksar'; texts, EDGAR, MASPERO, and DARESSY, *The Sarcophagus of an unknown Queen* in *Ann. Serv.* viii. 278-80, cf. 276-7, 281.

KÔM IBSHÂN

Statue of Nekhtnebf , First prophet of Onuris, holding naos of Onuris, in Cairo Mus.; text on back, DARESSY, *Statue de Kom Ebchan* in *Ann. Serv.* xii. 281-2.

SAKHA (XOÏS) 

Capital of the VIth nome of Lower Egypt.

Three basalt blocks with nome-figures and names of foreign countries, Ptolemaic, in Cairo Mus.; names of countries, id. *Notes et Remarques in Rec. de Trav.* xxiv. 160 [clxxxvii].

Stela of Augustus; text, id. *Une stèle de Xoïs* in *Ann. Serv.* xvii. 47.

Limestone plaque with series of demons, Ptolemaic or Roman, in Tanṭa Mus.; texts, id. *Sur une série de personnages mythologiques* in *Ann. Serv.* xxi. 2-6.

KAFR MATBÛL

Two colossal red granite double-statues of Merneptah with Rē', found in village; texts, GAUTHIER, *À travers la Basse-Égypte* in *Ann. Serv.* xxiii. 167, 168.

TELL EL-FARĀ'ÎN or IBṬU (BUTO) 

See PETRIE and CURRELLY, *Ehnasya*, pp. 36-7. Plan, id. ib. pl. xlv [lower].

Sword with cartouches of Sethos II, probably from here, in Berlin Mus. 20305, BURCHARDT, *Zwei Bronzeschwerter aus Ägypten* in *Ä.Z.* 1, pl. v [1], p. 61, Abb. 2; MEYER, *Darstellungen der Fremdvölker*, 840 [middle] (called 846 in text); cartouches, *Aeg. Inschr. Mus. Berlin*, ii. 311.

Headless sphinx with erased titles of Necho II (probably); text, EDGAR, *Notes from the Delta* in *Ann. Serv.* xi. 87.

Bas-relief from upper part of a wall, men and women bringing offerings to Ḥarhotp , High priest of Buto, Saite, in Cairo Mus., GAUTHIER, *À travers la Basse-Égypte* in *Ann. Serv.* xxi, pl. ii [upper], cf. pp. 27-32.

Cache of Saite bronzes found in a well, ENGELBACH, *Seizure of bronzes from Buto (Tell Farā'in)* in *Ann. Serv.* xxiv, pp. 169-77, with plan of site, and one plate.

TÎDA

Granite block with cartouche of Khufu, said to come from Tell Umm el-Ab or Kôm el-Kuwalla, north of Tîda; cartouches, FOUCART, *Notes prises dans le Delta* in *Rec. de Trav.* xvii, p. 100, § 1.

ṬANTA

Red granite fragment with cartouches of Amasis, dug up near mosque of Sheikh Sa'îd Ahmed el-Badawi, in Tanṭa Mus. 981; cartouches, GAUTHIER, op. cit. in *Ann. Serv.* xxiii. 71.

Granite block with beginning of protocol of Amasis, used as threshold in mosque ; text, id. ib. 72.

EL-BINDARĪA

Block with cartouches of Sesonchis II ; cartouches, DARESSY, *À travers les koms du Delta* in *Ann. Serv.* xii. 206 ; see GAUTHIER, *Le Livre des Rois*, iii. 366 [xxiv].

WEST PART

Map showing chief sites, DARESSY, *Une inscription d'Achmoun et la géographie du nome Libyque* in *Ann. Serv.* xvi. 243.

A. ROSETTA BRANCH OF THE NILF

ṢĀ EL-ḤAGAR (SAÏS) 

Capital of the Vth nome of Lower Egypt.

Plan, L. D. i. 55 [upper] ; WILKINSON MSS.* vi. 240, xvii. J. 8. View, L. D. i. 56 [lower], cf. *Text*, i, pp. 3-4. See also DARESSY, *Rapport sur les fouilles à Sa el-Hagar* in *Ann. Serv.* ii, pp. 230-9, with fig. 1.

ROYAL TOMBS IN TEMPLE-ENCLOSURE.

See HERODOTUS, ii. 169.

Scarab of Necho II, formerly in Collège des Jésuites in Paris, but now lost, CAYLUS, *Recueil d'Antiquités*, vii, pl. x [iii, iv], cf. pp. 29-30 ; see GAUTHIER, *Le Livre des Rois*, iv, p. 89, note 2.

MISCELLANEOUS

(From Saïs, but exact provenance unknown.)

Statues.

Double-statuette with stela on back, of Bubastis and Horus (?), dedicated by Pemū , Chief of the Meshwesh, son of Sesonchis III, in Cairo Mus. 9430, DARESSY, *Textes et Dessins magiques* (Cat. Caire), pl. xi, pp. 37-9 ; texts, id. *Notes et Remarques* in *Rec. de Trav.* xvi. 48-9 [cii].

Base of statuette of Isis the Scorpion, in name of Pemū , Priest (?), Dyn. XXIII (?), in Cairo Mus. ; texts, id. ib. xxiv. 160 [cxc].

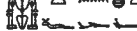
Headless black granite squatting statue of Semtu-tefnakht , Overseer of crews of the royal boats, temp. Psammetikhos I, probably from here, in Cairo Mus. ; texts, DARESSY, *Santawī-tafnekht* in *Ann. Serv.* xviii. 29-30. (Cf. infra pp. 119, 121.)

Black basalt torso of Psammetikhos II, in Cambridge, Fitzwilliam Mus. 394, YORKE and LEAKE, *Remarks on some Egyptian Monuments in England*, pl. xiii, fig. 38 ; texts, BUDGE, *A Catalogue of the Egyptian Collection in the Fitzwilliam Museum*, p. 122 ; see CLARKE, *Travels [&c.]* (1814), Pt ii, Sect. 2, p. 226.

Base of statue of Khenems-Ḥarmenkhīb-wēr , Chief lector of His Majesty, temp. Psammetikhos II ; text, MARIETTE, *Mon. Div.* pl. 102 [a].

Black basalt statue-base of Psammethēk, temp. Amasis, in Cambridge, Fitzwilliam Mus. 393, YORKE and LEAKE, op. cit. pl. xii, fig. 37 ; CLARKE, op. cit. plate opposite p. 221, cf. 220 ; text, MACALISTER, *An inscription of Aahmes in the Fitzwilliam Museum* in *P.S.B.A.* ix. 99 ; BUDGE, op. cit. pp. 120-2.



Bronze statue of Buto, dedicated by Amasis, with list of twelve Tuēris goddesses ; text, DARESSY, *Thouēris et Meskhenit* in *Rec. de Trav.* xxxiv. 190-1.



Statue of Uzahor-shema'nt , Prophet of Amasis, &c.; text, BRUGSCH, *Thes.* 1449 [68].

Statues of Weḥebrē' , Overseer of the frontier, Director of the temples, Dyn. XXVI. (a) Kneeling statue (headless) holding pyramidal shrine, in Cairo Mus. 672, BORCHARDT, *Statuen und Statuetten* (Cat. Caire), iii, pl. 122, pp. 18-20; texts, DARESSY, *Notes et Remarques* in *Rec. de Trav.* xvii. 114-16 [cxxix]. (b) Lower half of kneeling statue holding naos, in Cairo Mus. 679; texts, BORCHARDT, op. cit. iii, p. 24; GAUTHIER, *À travers la Basse-Égypte* in *Ann. Serv.* xxii. 92. (c) Three squatting statues in Cairo Mus. (Journal d'entrée, 34043, 34044, and another); texts, id. ib. 88-9, 90. (d) Squatting (?) statue, perhaps from here, present whereabouts unknown, cast formerly in London, Crystal Palace; texts, SHARPE, *Eg. Inscr.* 2 Ser. 65 [right lower]; GAUTHIER, op. cit. 94. (e) Grey granite squatting statue, perhaps from here, in Louvre A. 91, BOREUX, *Guide-Catalogue Sommaire* (1932), i, pl. iii [left], cf. p. 51; texts, BRUGSCH, *Thes.* 687 [bottom], cf. 1461 [108]; PIEHL, *Inscr. Hiéro.* 1 Sér. xii D; GAUTHIER, op. cit. 95; text on base, PIERRET, *Inscr. du Louvre*, ii. 8 [bottom]. (f) Fragment of kneeling statue holding naos, perhaps from here, in Cairo Mus.; texts, GAUTHIER, op. cit. 93.

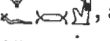
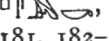

(See also statues of Weḥebrē', supra pp. 5, 6, and sarcophagus lid, infra p. 48.)

Head of young King, Dyn. XXVI, in Berlin Mus. 11864, *Aeg. und Vorderasiat. Alterthümer*, pl. 120; BISSING, *Denkmäler, Text* to 72 [fig.]; CAPART, *L'Art égyptien* (1909), pl. 85; SCHÄFER and ANDRAE, *Die Kunst des Alten Orients*, 422; STEINDORFF, *Die Kunst der Ägypter*, p. 257; see *Ausführ. Verzeichnis* (1899), p. 247.

Four statues, Saite, (a) of Ḥarpi-ardais , Prophet of Osiris, kneeling with naos of Osiris, (b) in limestone, of goddess Neith, (c) in schist, of Tefnakht , Prophet of Horus, Neith, &c., (d) in black granite, inscribed for Ḥrafaneith , and Psammethek , Prophets of Horus; texts, DARESSY, *Notes et Remarques* in *Rec. de Trav.* xiv. 181, 182-3 [lxxvii, lxxix-lxxx].

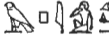
Statue in schist of Isis suckling Horus, dedicated by Nekht-Ḥarḥebi , good name Neferebrē'-sineith , Royal herald, Saite, in Cairo Mus. 39303; texts, id. *Statues de Divinités* (Cat. Caire), p. 326; id. op. cit. in *Rec. de Trav.* xiv. 181-2 [lxxviii].

Squatting statue of a son of Pedehor  and Ḥarpi-ardais , Saite (?), in Cairo Mus. 712, BORCHARDT, op. cit. iii, pl. 132, p. 50.

Statue of Pdebḥu , Prophet of Horus, Director of the Residences, holding naos of Osiris, and statue of Psammetheksonb , Chief physician, holding naos of Neith, both Saite, in Vatican Mus. 91, 92; texts, MARUCCHI, *Catalogo del Museo Egizio Vaticano*, pp. 63-7; PIEHL, *Inscr. Hiéro.* 1 Sér. xxvii-xxviii E, xxvii D; WIEDEMANN, *Die saïtischen Monumente des Vatikans* in *Rec. de Trav.* vi. 119 [2], 122 [6]; names and titles, BRUGSCH, *Thes.* 1449 [71, 70].

Statuette of Neith, with stela of Horus on the crocodiles on back, Saite, in Cairo Mus. 9431 bis; texts, DARESSY, *Textes et Dessins magiques* (Cat. Caire), 40-1.

Torso of priestess of Saïs, Saite, probably from here, in Bukharest, Simu Mus., ROEDER, *Der 'Torso Simu' einer Priesterin aus Saïs* in *Studies presented to F. Ll. Griffith*, pls. 52, 53 [b], cf. pp. 332-40.

Statuette of goddess Buto, Ptolemaic, in Cairo Mus.; texts, GAUTHIER, op. cit. in *Ann. Serv.* xxi. 37-8.

Base of black basalt statue with magical text, Persian or Ptolemaic, in Cairo Mus. 9432; texts, DARESSY, op. cit. 42-3; id. *Notes et Remarques* in *Rec. de Trav.* xiv. 176-7 [lxxi].

(For statue of Arsinoë II, in Vatican Mus., said by BRUGSCH to come from Saïs, see *infra* p. 63.)





Coffins.

Sarcophagus of Wehebrē' , Overseer of the frontier, Director of the temples, Dyn. XXVI, found at Tell Kawâdi; texts, WILKINSON MSS.* vi. 243 verso; of lid (not in WILKINSON), GAUTHIER, *op. cit.* in *Ann. Serv.* xxii. 84-5, cf. 83; titles, BRUGSCH, *Dict. Géog. Supp.* 1288. Fragment apparently from same sarcophagus; text, MARIETTE, *Mon. Div.* pl. 106 [D]; see GAUTHIER, *op. cit.* 85.

Fragment of sarcophagus of Harkhebi , Chief physician of the Great House, Saite or Ptolemaic (?); text, *id. ib.* 202-3; titles, LIEBLEIN, *Dict. de Noms*, ii, p. 834, No. 2354.

Grey granite sarcophagus of P-ar-kep , Director of the temples, Royal herald, Captain of troops, &c., Saite or later. Fragment 1 found about 1750, now in Brit. Mus. 66; some texts and figures, NIEBUHR, *Reisebeschreibung* (1774), i, pls. xxxi-xxxv, pp. 205-6; outside, ALEXANDER, *Egyptian Monuments* (1805-7), eleventh plate; SHARPE, *Eg. Inscr.* 1 Ser. 40-1; titles, LIEBLEIN, *op. cit.* i, p. 405, No. 1257; inside, ALEXANDER, *op. cit.* sixth plate. Fragment 2, formerly in Oxford, Ashmolean Mus., now in Brit. Mus. 1387, joined to fragment 1 (cf. *Guide*, Sculpture (1909), p. 240 [882, 883]), PERRY, *A View of the Levant* (1743), pl. 33; SHARPE, *Eg. Inscr.* 2 Ser. 76; *Marmora Oxoniensis* (1763), Pt. ii, pl. ii [vii, 1 and 2]; titles, LIEBLEIN, *op. cit.* i, p. 251, No. 759. Fragment 3, in Naples; titles, BRUGSCH, *Thes.* 1443 [51]; text of fragment 3, showing connexion with fragment 2, PIEHL, *Varia* in *Rec. de Trav.* i. 198, § 5. (For part of lid, see Cairo, *infra* p. 71.)

Basalt sarcophagus of Sisobk , Priest of Ptah and Governor of the City of Saïs, Ptolemaic, in Brit. Mus. 17, BUDGE, *Egyptian Sculptures in the British Museum*, pl. liv; text on lid, SHARPE, *Eg. Inscr.* 2 Ser. 34 B; PIEHL, *Inscr. Hiéro.* 3 Sér. xxxix T, cf. p. 29; see *Guide*, Sculpture (1909), p. 240 [881].

Sarcophagi of Ef'o , good name Neferebrē'-mai-neith , Nekht-Harhebi , good name Nekht-Harmenkhib , and Psammethek , Priest of Sekhmet (fragment), in Vatican Mus. 3, 6, 7; part of texts, MARUCCHI, *op. cit.* pp. 16-19, 24-6; WIEDEMANN, *op. cit.* in *Rec. de Trav.* vi. 116-18 [1-3]; names and titles, BRUGSCH, *Thes.* 1449-50 [72-4]; texts of Ef'o, PIEHL, *Petites notes de critique et de philologie* in *Rec. de Trav.* iii. 70-1, § 35.

Various.

Headless sphinx, in Cairo Mus., Psammetikhos I or II; texts on stand, GAUTHIER, *op. cit.* in *Ann. Serv.* xxi. 36-7.

Basalt column of Apries, in Cairo Mus.; texts, DARESSY, *Rapport sur des fouilles à Sa el-Hagar* in *Ann. Serv.* ii. 239; GAUTHIER, *op. cit.* in *Ann. Serv.* xxii. 199. (For two others, see Ganâg, *infra* p. 49, and Cairo, *infra* p. 71.)

Fragment of basalt naos of Apries, probably from here, formerly in Amherst Collection, now in Brussels, Musées Royaux du Cinquanteaire, E. 5818, CAPART, *Un fragment de naos saïte* in *Mém. Acad. Roy. Belgique*, 2 Ser. xix, pls. i-iii and fig. i; texts, SPELEERS, *Rec. des Inscr. Ég.* 87-8 [334].

Stela, year 8 of Amasis, recording dedication of a court and land to Neith, in Brit. Mus. 1427, *Guide*, Sculpture (1909), pl. xxix, cf. p. 224 [808]; see *Guide to the Egyptian Collections* (1909), p. 260.

Offering-table of Amasis, in Brit. Mus. 94, see *Guide*, Sculpture (1909), p. 223 [806].

Fragment of bas-relief from tomb, cattle led for sacrifice, Saite, in Cairo Mus., MASPERO, *Le Musée Égyptien*, ii, pl. xxxviii [middle], cf. p. 82 [B].

Offering-tables, no names, Saite, in Cairo Mus. 23112, 23113, 23195, KAMAL, *Tables d'Offrandes* (Cat. Caire), pl. xxvi, pp. 93, 138-9.

Black granite stela, year 7 of Alexander II, known as the 'Satrap's Stela', built into Mosque Sheikhûn in Cairo, now in Cairo Mus. 22182, MARIETTE, *Mon. Div.* pl. 14; KAMAL, *Stèles Ptolémaïques et Romaines* (Cat. Caire), pl. lvi, pp. 168-71; BORCHARDT and REISNER, *Works of Art*, 30; MASPERO and ROEDER, *Führer* (1912), pl. 40; text, BRUGSCH, *Ein Decret Ptolemaios' des Sohnes Lagi, des Satrapen* in *Ä.Z.* ix. 1-8; SETHE, *Urk.* ii. 11-22 (9); see MASPERO, *Guide* (1914), pp. 190-1 [795]. (See infra p. 73.)

Fragment of monolithic granite naos from Temple, year 20 of Ptolemy II Philadelphus, in Louvre C. 123; text, PIEHL, *Inscr. Hiéro.* 1 Sér. xxii-xxiii D; SETHE, *Urk.* ii. 75-80 (19); WILKINSON MSS.* xiv. 53; ll. 7-11, and part of beginning, REVILLOUT, *Notes historiques sur les Ptolémées* in *Rev. Égypt.* i. 183-6; see BOREUX, *Guide-Catalogue Sommaire* (1932), i, p. 79.

Fragment of cubit measure with astronomical text, in Cairo Mus.; text, DARESSY, *Notes et Remarques* in *Rec. de Trav.* xx. 78 [clvi].

Fragment of obelisk, with gods of the four winds, NASH, *Notes on some Egyptian Antiquities* in *P.S.B.A.* xxxii, pls. xxvii, xxviii, cf. pp. 193-4 [42].

GANÂG

Basalt column of Apries, originally from Saïs, in Cairo Mus.; texts, GAUTHIER, op. cit. in *Ann. Serv.* xxii. 201. (Possibly same column, WILKINSON MSS.* xviii. 67 [upper left].) (For two others, see supra p. 48, and Cairo, infra p. 71.)

EL-NAḤḤÂRIYA

Blocks from temple, Psammetikhos II and Apries, L. D. iii. 274 h, i, and *Text*, i, p. 4.

B. WEST OF ROSETTA BRANCH OF THE NILE



DAMANHÛR

Group of four 'Hyksos' heads, in Cairo Mus. 1165, EVERS, *Staat aus dem Stein*, ii, pl. vi [48] (incorrectly called Tanis), cf. pl. vii [50]; see MASPERO, *Guide* (1914), p. 141 [499] (incorrectly called Tanis).

Black granite naos of Neith dedicated by Nektanebos I (Nekht-neb-f), perhaps from here, in Cairo Mus.; texts, DARESSY, *Remarques et Notes* in *Rec. de Trav.* xi. 80-1 [xxii]; see MASPERO, op. cit. p. 192 [807].

Quartzite hollow base for sacred hippopotamus (?), (not a sarcophagus), with text of Psammetikhos II, in Cairo Mus.; texts, MASPERO, *Notes sur quelques points de grammaire et d'histoire* in *Ä.Z.* xxii. 79 [xlvii]; see id. *Guide* (1914), p. 207 [922]; GAUTHIER, *Le Livre des Rois*, iv, p. 97 note 2.

Granite libation-dish of Uzaḥor-shema'nt , good name Neferebrē'-nebpeḥti

 , Commander of troops, Dyn. XXVI, *Descr. de l'Égypte, Ant.* v, pl. 74.

Fragment of bas-relief with figure of Isis, id. ib. pl. 73 [13, 14].



(For Damanhûr stela, see infra p. 50.)

EL-BARNÛGI

Pair of stone-built tombs with painted scenes, the western one of Sit-Ḥathor , the eastern without name, Dyn. XI; remains of scenes, and jewellery, EDGAR in MASPERO, *Le Musée Égyptien*, ii, pp. 109-18, with figs. 1-18 and pls. lvi-lvii.

Blocks of Tuthmosis and of Ramesses II; texts, EDGAR, *Inscribed stones at Kom Frin and Kom Barnougi* in *Ann. Serv.* xi. 278.

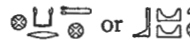
KÔM GI'EIF, EL-NIBEIRA, and EL-NIQRÂSH

(NAUCRATIS)  or 

See PETRIE and GARDNER, *Naukratis*, i, passim; GRIFFITH in id. ib. ii, pp. 80-1, 83-4. Plans of site, PETRIE and GARDNER, op. cit. i, pls. xl, xli; plans of Great Enclosure, id. ib. pls. xlii, xliii.

FROM TEMPLE (DESTROYED), probably within Great Enclosure.



Basalt stela, year 1 of Nektanebos I (Nekht-neb-f), in Cairo Mus., MASPERO, *Une stèle de Nectanébo II* in *Comptes Rendus* (1899), plate opposite p. 794; GRÉBAUT, *Le Musée Égyptien*, i, pl. xlv, cf. pp. 40-4; text, ERMAN and WILCKEN, *Die Naukratisstele* in *Ä.Z.* xxxviii. 127-33; see SETHE, *Zur Erklärung der Naukratisstele* in *Ä.Z.* xxxix. 121-3; MASPERO, *Guide* (1914), pp. 198-9 [850].

Three sides of fragment of red granite obelisk of Ptolemy I Soter I (?), in Ṭaṭṭa Mus.; texts, EDGAR, *Some hieroglyphic inscriptions from Naukratis* in *Ann. Serv.* xxii. 1.



Two basalt blocks with nome-list of Ptolemy I Soter I, in Ṭaṭṭa Mus.; texts, id. ib. 4-5, cf. 2-3.

Blocks with Nile-gods; text, GRIFFITH, *Tell el Yahûdiyeh*, p. 69.

Limestone stela, 'Damanhûr stela', decree of year 23 of Ptolemy V Epiphanes, with copy of hieroglyphic text of Rosetta stone, probably from Great Enclosure, in Cairo Mus. 22188 [cf. PETRIE and GARDNER, ii, p. 83], BOURIANT, *La stèle 5576 du Musée de Boulaq et l'inscription de Rosette* in *Rec. de Trav.* vi, pp. 2-14 and plate; KAMAL, *Stèles Ptolémaïques et Romaines* (Cat. Caire), pls. lxii, lxiii, pp. 183-7; text, SETHE, *Urk.* ii. 169-98 (36) N, cf. 166-9; REVILLOUT, *Les Deux Versions Hiéroglyphiques du Décret de Rosette* in *Rev. Égypt.* xiii. 44-108; BAILLET, *Le Décret de Memphis et les inscriptions de Rosette et de Damanhour* (1888), passim, reprinted in *Bibliothèque Ég.* xv, pp. 245-401; beginning of text, MASPERO, op. cit. in *Ä.Z.* xxii. 78 [xlvi].

Granite altar-base with name of Nekhtnebf , son of Tefnakht , early Ptolemaic, in Cairo Mus.; text, DARESSY, *Notes et Remarques* in *Rec. de Trav.* xxii. 140-1 [clxxi].

Fragments of inscribed basalt bowls, found on north side of temenos, GRIFFITH in PETRIE and GARDNER, op. cit. ii, pl. xxiii [3-6], cf. p. 81.

Broken statue of Haremḥab , Prophet of Min, son of Krates , Saite or Ptolemaic, in Cairo Mus.; text, DARESSY, *Notes et Remarques* in *Rec. de Trav.* xix. 21-2 [cxlvii]; see MASPERO, *Guide* (1914), p. 246 [2005].

C. WESTERN EDGE

KÔM EL-ABQA'EIN

Two blocks from door of Ramesses II; cartouches, DARESSY, *Rapport sur Kom el-Abq'ain* in *Ann. Serv.* v. 130.

KÔM FIRIN

(Kôm Afrin of PETRIE.)

See PETRIE and GARDNER, *Naukratis*, i, pp. 94-5; GRIFFITH in id. ib. ii, pp. 80 [12], 83.

Two column-bases of Ramesses II; text, EDGAR, *Inscribed stones at Kom Frin ana Kom Barnougi* in *Ann. Serv.* xi. 277.

Probably from Kôm Firin.

Tablet of Sekhmet dedicated by Huy , Scribe, Ramesside, bought at Naucratis, in Brit. Mus., GRIFFITH in PETRIE and GARDNER, op. cit. ii, pl. xxiii [2], cf. p. 81, and i, p. 94.

Kneeling statue of Psammetheksonb , Mayor in Sais, bought in Cairo; texts, GRIFFITH, op. cit. pl. xxiii [I, A-C], cf. p. 81; see PETRIE and GARDNER, op. cit. i, p. 94; MASPERO, op. cit. in *Ä.Z.* xxii. 80 [xlvi].

Bronze figure-head of bark of Rē', with prenomen of Amasis, in Brit. Mus., PETRIE and GARDNER, op. cit. i, pl. xii [upper], cf. p. 95.

KÔM EL-HIṢN 

Capital of the IIIrd nome of Lower Egypt.

See GRIFFITH in PETRIE and GARDNER, op. cit. ii, pp. 77-9, 82-3.

TEMPLE OF SEKHMET-HATHOR. (Entirely destroyed.)

Plan showing positions of statues of Ramesses II, id. ib. pl. xxiv [top].

Basalt statue-group (headless), Amenemhēt III and two princesses, in Cairo Mus., EVERS, *Staat aus dem Stein*, i, pls. 99, 100, cf. pp. 91-2 with Abb. 23; texts, EDGAR in MASPERO, *Le Musée Égyptien*, iii, p. 63.

Lower parts of two double-statues, one seated, one standing, Ramesses II and goddess, probably originally before Pylon (destroyed); texts, GRIFFITH in PETRIE and GARDNER, op. cit. ii, pl. xxiv [i, ii], cf. pp. 77-8.

Two colossal statues, one sandstone, one red granite, Middle Kingdom, usurped by Ramesses II, perhaps originally within gateway; texts, id. ib. pl. xxiv [iii, iv], cf. p. 78; DARESSY, *Rapport sur Kom el-Hisn* in *Ann. Serv.* iv. 282-3.

Four blocks from jambs of chapel of Sesonchis II; texts, id. ib. 283-5 [A-D]; see GAUTHIER, *Le Livre des Rois*, iii. 366 [xxii].

Stela with trilingual decree of Canopus, year 9 of Ptolemy III Euergetes I, in Cairo Mus. 22186, KAMAL, *Stèles Ptolémaïques et Romaines* (Cat. Caire), pls. lix-lxi, cf. pp. 182-3; KRALL, *Demotische Lesestücke*, Pt. ii, passim; text, SETHE, *Urk.* ii. 123 (29), 124-54 (30) κ, 156; variants from Tanis text, BRUGSCH, *Theb.* 1575-8; see MASPERO, *Guide* (1914), p. 219 [983]; GRIFFITH in PETRIE and GARDNER, op. cit. ii, p. 79.

PAINTED STONE TOMB OF KHESU-WER , Prophet of Hathor; Inspector of prophets; Overseer of the harim of maidens. Middle Kingdom. South-west of Temple.

Entrance.

Lintel and jambs, EDGAR in MASPERO, *Le Musée Égyptien*, iii, p. 55, figs. 1, 2, and p. 56.

Hall.

East wall. Upper part, offering-scene, false door, offerings, and offering-text, lower part, religious texts and recess; upper part, omitting false door and offering-texts, id. ib. pls. xxxiii, xxxiv, pp. 57 [bottom]-58 [top]; frieze-text, and offering-texts from recess, id. ib. pp. 57 [middle], 58 [middle].

South wall. Offerings (damaged), and religious texts below; one row of offerings, id. ib. p. 58, fig. 4.

West wall. Upper part, scenes, lower part, three registers religious texts. Upper part, south end, four registers women musicians before deceased, centre, three registers,

bringing cattle, butchers, and ploughing, north end, two registers, deceased fowling and fishing in marshes and men with fowls in draw-net below, and deceased worshipping beyond, id. ib. pls. xxxv, xxxvi, pp. 58 [bottom]-59, with fig. 5.

Ceiling. Texts, id. ib. p. 60.

Head of Amenemhêt III (?), found in tomb, and probably from Temple of Hâthor, now in Cairo Mus., id. ib. pl. xxxii, cf. pp. 54, 61-2; EVERS, op. cit. i, pl. 101.

II. FROM THE RED SEA CANAL TO THE NILE

SUEZ TO EL-TELL EL-KEBÎR

Map, NAVILLE, *The Store-City of Pithom* [&c.], 4th ed. (1903), first map after p. 40; MÉNANT, *La stèle de Chalouf* in *Rec. de Trav.* ix. 133; south-east part, CLÉDAT, *Notes sur l'isthme de Suez* in *Bull. Inst. Fr. Arch. Or.* xvi, last plate but one.

SUEZ

KÔM EL-QULZUM (CLYSMA)

Two fragments of a block from monument of Ramesses II, in Berlin Mus. 11164, *Aeg. Inschr. Mus. Berlin*, ii. 236, cf. *Ausführ. Verzeichnis* (1899), p. 118.

ANCIENT CANAL FROM RED SEA TO WÂDI TUMMILÂT

NORTH OF HEAD OF GULF OF SUEZ

Red granite bilingual (hieroglyphic and Persian) stela of Xerxes, at kilometre 83 from Isma'ilia (part removed, of which one fragment of top is said to be in the Louvre, and others re-used in native houses); texts of parts *in situ*, CLÉDAT, op. cit. pp. 226-7.

Head of colossal sandstone seated statue of Psammetikhos II, with remains of inscribed throne, said to have been found near south end of Suez Canal, in Brit. Mus. 1238; head, *Guide to the Egyptian Collections* (1909), fig. on p. 259; (1930), p. 386, fig. 212; see *Guide, Sculpture* (1909), p. 222 [803].

BETWEEN EL-SHALLÛFA AND EL-KABRÎT

Broken quadrilingual red granite stela of Darius I, with Persian, Median, and Akkadian inscription on front, and hieroglyphic on back, at kilometre 61 from Isma'ilia, now in Isma'ilia Mus., MÉNANT, op. cit. 145, 142; back, MASPERO, *Pièces relatives à la découverte du monument de Chalouf* in *Rec. de Trav.* vii, plate opposite p. 4; all texts, DARESSY, *Révision des textes de la stèle de Chalouf* in *Rec. de Trav.* xi. 160-71; see CLÉDAT, op. cit. pp. 201-3.

Red granite fragments with cuneiform text of Darius I, from another stela (exact position uncertain), found by DEVILLIERS and ROZIÈRE, *Descr. de l'Égypte, Ant.* v, pl. 29 [1-4], cf. *Texte*, v, pp. 151-3, x, p. 501; see MÉNANT, op. cit. 132-4, 136 [1°].

NORTH OF BITTER LAKES

Fragments of stela of Darius I with Persian inscription, near Serapeum, at kilometre 14 from Isma'ilia, apparently recently destroyed without record, see NAVILLE's letter in MÉNANT, op. cit. 137.

Fragments of red granite stela of Darius I, one kilometre south of Tell el-Maskhûta, in Cairo Mus., GOLÉNISCHEFF, *Stèle de Darius aux environs de Tell el-Maskhûtah* in *Rec. de Trav.* xiii, pl. viii opposite p. 102.

ANCIENT CARAVAN ROUTE FROM RED SEA TO WĀDI TUMMILĀT

GEBEL MURR

Red granite stela of Ramesses II before Sopt, inscribed on four faces, now at Isma'ilia; names of Sopt, Anta, and Ba'al, CLÉDAT, op. cit. in *Bull. Inst. Fr. Arch. Or.* xvi. 208.

GEBEL ABŪ HASSA

Red granite stela of Ramesses II before Sopt, inscribed on four faces, now at Isma'ilia; names of Sēth, Sopt, and Anta, id. ib. p. 207.

TEMPLE OF HORUS AND ḤATHOR. Dyn. XVIII, usurped by Ramesses II, re-used in Roman Period.

Plan, id. ib. p. 209, fig. 3.

Remains of reliefs of Sethos I and Ramesses II, at Isma'ilia, id. ib. p. 210, fig. 4, cf. pp. 208-12.

Fragment of stela; name of Ḥathor of Mafek, id. ib. p. 212.

WĀDI TUMMILĀT

Map, SCHOTT, *Bericht* [&c.] in *Mitteil. d. Deutsch. Inst. Kairo*, ii, map after plate xiii.

TELL EL-MASKHŪṬA (PITHOM) 

Capital of the VIIIth nome of Lower Egypt.

See NAVILLE, *The Store-City of Pithom* [&c.], 4th ed. (1903), passim. Plan, id. ib. second map after p. 40. View of store-chamber, PETRIE, *Tanis*, i, pl. xvi [2].

TEMPLE. (Destroyed.)

Monolithic statue-group *in situ*, Ramesses II between Rē' and Atum, *Descr. de l'Égypte, Ant.* v, pl. 29 [6-8], cf. *Texte*, v, pp. 146-7; WILKINSON, *Mat. Hiero.* (1828), Appendix No. 4; PRISSE, *Mon.* xix [4, 5]; PETRIE, op. cit. i, pl. xvi [3]; text on back. LABORDE and LINANT, *Voyage de l'Arabie Pétrée* (1830), pl. 5 [top left], and fig. on p. 39.

Low cavern-like quartzite naos (monolithic) containing sphinx of Ramesses II, now at Isma'ilia, PETRIE, op. cit. i, pl. xvi [5]; title and cartouches, NAVILLE, op. cit. pl. 3 [A], cf. p. 15.

Black granite hawk of Rē'-Ḥarakhti, with cartouches of Ramesses II, in *Brit. Mus.* 1006, id. ib. pl. 12, cf. p. 4; see *Guide, Sculpture* (1909), p. 164 [596].

Grey granite sphinx, 'Hyksos' style, usurped by Ramesses II, at Isma'ilia, PETRIE, op. cit. pl. xvi [4], cf. p. 11.

Fragment of black basalt sphinx of Ramesses II; remains of text, NEUFFER, BITTEL, and SCHOTT, *Bericht* [&c.] in *Mitteil. d. Deutsch. Inst. Kairo*, ii, p. 58 [upper middle].

Limestone stela of peculiar form with three sculptured faces, King before god, King with throw-stick and stick, King with prisoner, Middle Kingdom usurped by Sethos I, found at foot of monolithic statue-group (see *supra*), NAVILLE, op. cit. pl. 6, cf. pp. 14, 17; DARESSY, *Un monument du temps des Hyksos* in *Ann. Serv.* xv, pls. i, ii, pp. 259-68, with figs. 1-4, 6-7.

Fragment of black granite tablet of Sesonchis I used as a mortar, NAVILLE, op. cit. pl. 3 [B], cf. pp. 4, 15.

Red granite squatting statue of 'Ankh-khred-nūfer , Agent of Theku (Succoth), Good recorder of Pithom, holding naos of Atum, temp. Osorkon II, in *Brit. Mus.* 1007, id. ib. frontispiece and pl. 4, cf. pp. 15-16; *Guide to the Egyptian Collections* (1909), p. 254; (1930), p. 380, fig. 209; see *Guide, Sculpture* (1909), p. 215 [776].



Bust of black granite seated statue, perhaps Osorkon II (according to NAVILLE), from store-houses north-east of Temple (1 in NAVILLE's plan), in Cairo Mus. 38232, DARESSY, *Statues de Divinités* (Cat. Caire), pl. xiii, cf. p. 67; see NAVILLE, op. cit. pp. 5, 12.

Grey granite squatting statue of 'Aok , Hereditary prince, Overseer of prophets of Atum in Theku (Succoth), probably Dyn. XXII, in Cairo Mus. 564, BORCHARDT, *Statuen und Statuetten* (Cat. Caire), ii, pl. 95, pp. 113-14; texts, NAVILLE, op. cit. pl. 5, cf. pp. 16-17.

Fragments of two black granite statues, one temp. Psammetikhos II, found beside monolithic statue-group (see supra p. 53), now at Isma'ilia; texts, id. ib. p. 40.

Fragment of vase of Apries, NEUFFER, BITTEL, and SCHOTT, op. cit. pl. xi [e], cf. p. 58 [5].

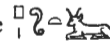
Lid of black granite sarcophagus of Uzahor-shema'n , Director of the Palace, Saite or Persian, found in closed chamber north-west of Temple; text, CLÉDAT, *Un couvercle de sarcophage anthropoïde de Tell el-Maskhoutah* in *Ann. Serv.* ix. 211-12.

Fragments of statues of Pshenehe , Scribe of the temple of Atum of Theku (Succoth), and of a priest whose mother is named Eswëre , probably Saite; texts, NAVILLE, op. cit. pl. 7 [A, B], cf. pp. 17-18.

Blocks of Nektanebos II (Nekht-ḥar-ḥebi), found by east wall and entrance to Temple, now in Isma'ilia Mus.; texts, and block with goddess Nut, CLÉDAT, *Notes sur l'isthme de Suez* in *Rec. de Trav.* xxxvi, pp. 111-12 [xi], with fig. 5.

Inscribed fragments, Nektanebos II (Nekht-ḥar-ḥebi), probably from near last, NEUFFER, BITTEL, and SCHOTT, op. cit. pl. xi [d], p. 58 [top].

Fragment of relief with head of Nektanebos II (Nekht-ḥar-ḥebi), PETRIE, *Tanis*, i, pl. xii [7], cf. p. 28.

Stela of Ptolemy II Philadelphus, found near monolithic naos containing sphinx (see supra p. 53), now in Cairo Mus. 22183, NAVILLE, op. cit. pls. 8-10, cf. pp. 14, 18-21; id. *La stèle de Pithom* in *Ā.Z.* xl, pls. iii-v, cf. pp. 66-75; KAMAL, *Stèles Ptolémaïques et Romaines* (Cat. Caire), pl. lvii, pp. 171-7; ANDERSSON-AKMAR, *La Stèle de Pithom* in *Sphinx*, xxii. 72-80; texts, SETHE, *Urk.* ii. 81-105 (20); BRUGSCH and ERMAN, *Die Pithomstèle. Eine hinterlassene Arbeit* in *Ā.Z.* xxxii. 75-87; titles, BRUGSCH, *Thes.* 855 [bottom right]; cartouches of Arsinoë II, NAVILLE in LEPSIUS, *Über die Lage von Pithom (Sukkoth) und Raïmses (Heroonpolis)* in *Ā.Z.* xxi. 44; see ANDERSSON and SJÖBERG, *La Stèle de Pithom et les Estampages de M. Ed. Naville* in *Sphinx*, viii. 223-36; MASPERO, *Guide* (1914), p. 199 [851].

Base of statue of Arsinoë II, wife of Ptolemy II Philadelphus; cartouches of Queen, NAVILLE, op. cit. pl. 7 [c], cf. p. 5; id. op. cit. in *Ā.Z.* xxi. 44, cf. 43 [bottom].

Sandstone stela, trilingual (hieroglyphic, demotic, and Greek), year 6 of Ptolemy IV Philopator, in Cairo Mus., GAUTHIER and SOTTAS, *Un Décret Trilingue en l'Honneur de Ptolémée IV*, passim; see GAUTHIER, *Un nouveau décret* [&c.] in *Comptes Rendus* (1923), 376-83.

Fragment with epithets of a king, in a house; text, EDGAR, *Notes from my Inspectorate* in *Ann. Serv.* xiii. 279.

Two bronze door-hinges with text of Pedeatum , said to be from here, in Isma'ilia Mus., CLÉDAT, op. cit. in *Rec. de Trav.* xxxvi, pp. 104-5 [i], figs. 1, 2.

Cache near Entrance of Temple.

Fragments of schist tablet, Protodynastic, id. *Deux monuments nouveaux de Tell el-Maskhoutah* in *Rec. de Trav.* xxxii, p. 41, fig. 1.

Cylinder of a high official at the Pyramids, &c., of Isesi, Pepy I, Merenrē I, and Pepy II, perhaps the well-known Weni of Abydos; text, id. ib. pp. 41-2, fig. 2.

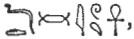
Base of bronze statue of goddess Nepit (?) dedicated by Zenetef'onkh , Royal scribe; text, id. op. cit. in *Rec. de Trav.* xxxvi. 105-7 [ii], with fig. 3.

Head of sandstone statue of Ukermen , Prophet of Bubastis, id. ib. pp. 107-8 [iii], with fig. 4.

Inscribed objects of Amasis, Cambyses (apparently), Nektanebos I and II, and others (Saite) without royal names; texts, id. ib. pp. 108-11 [iv-ix].

TELL EL-RATÂBA

PETRIE, *Hyksos and Israelite Cities*, pls. xxviii [right]-xxxiv c, xxxv b-xxxvi c, pp. 28-34. Plan (inaccurate) and sections, NAVILLE, *Goshen*, pl. 11; plans, PETRIE, op. cit. pls. xxxv, xxxv a.

TEMPLE OF ATUM (?). Ramesses II.

Left part of façade, King smiting Syrian before Atum, and top of right part, remains of similar scene before Sêth, found in east part of site, id. ib. pls. xxix, xxx, xxxi [top], cf. p. 31.

Red granite double-statue, King and Atum, found in Temple-enclosure, id. ib. pl. xxxii [top right], cf. p. 30.

Lower part of red granite stela, found near last, id. ib. pls. xxviii [right], xxxii [middle right], cf. pp. 30, 31.

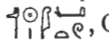
Blocks from Temple, including one of Ramesses III, and jamb from tomb of Userma'etrê'-nakht , Captain of bowmen, Overseer of the Residence of Theku (Succoth), Dyn. XX, id. ib. pl. xxxi [middle and bottom], cf. p. 31.

Outer wall of Ramesses III.

Foundation deposit under south-east corner, id. ib. pls. xxxii a [left lower], xxxiv [middle], cf. p. 30.

Found in rubbish.

Jasper weight of Khety , Dyn. IX, id. ib. pl. xxxii a [left upper], cf. p. 32; see GAUTHIER, *Le Livre des Rois*, i. 362 [top].

EL-TELL EL-KEBÎR

TELL ŞAMAD.

Inscribed block from lintel, and jamb with figure of deceased, from a tomb, Middle Kingdom, NEUFFER, BITTEL, and SCHOTT, op. cit. in *Mitteil. d. Deutsch. Inst. Kairo*, ii, pl. xi [a, b], pp. 56-7.

EL-ṬAWÎLA, see supra p. 10.

III. SOUTHERN DELTA

EAST PART

BILBEIS TO CAIRO

BILBEIS

Red granite block of Merneptah; cartouche, EDGAR, *Notes from my Inspectorate in Ann. Serv.* xiii. 279 [near bottom].

TEMPLE OF NEKTANEBOS II (NEKHT-ḤAR-ḤEBI). (Entirely destroyed.)

Fragments in various houses.

Jamb of black granite shrine; text, NAVILLE, *Mound of the Jew*, pl. ii [a], cf. p. 22; EDGAR, op. cit. 280 [left].

Red granite block with remains of seven columns of text; text, id. ib. 279 [bottom]; JUNKER, EILMANN, SCHOTT, and STIER, *Bericht* [&c.] in *Mitteil. d. Deutsch. Inst. Kairo*, i, p. 30.

Texts from different fragments, NAVILLE, op. cit. pl. ii [b, c], cf. p. 22; EDGAR, op. cit. 280 [right]; JUNKER, &c., op. cit. p. 31, Abb. 3 [a, b, d].

EL-SHAGHÂMBA

TOWN AND FORT. Dyn. XIX, Dyn. XXII-XXVI.

See PETRIE, *Hyksos and Israelite Cities*, pp. 52-4, pl. xxxix L [lower]. Plan, id. ib. pl. xxxix M.

Sculptors' trial-piece, with head on one side and figure on the other, found in a house, id. ib. pls. xix D [left], xxxix L [18], cf. p. 54.

Alabaster jar with inscription of 'Taitha', Dyn. XIX, id. ib. pl. xxxix L [17], cf. p. 54.

GHÎTA or TELL YEHUD

TOWN AND FORT. Dyn. XXII and Roman Period.

See DUNCAN in id. ib. pp. 54-5.

CEMETERY. Roman.

See id. ib. pp. 55-65, pls. xl-xlix.

TELL EL-YAHÛDÎYA ('HELIOPOLITAN LEONTOPOLEIS')

NAVILLE, *Mound of the Jew*, and GRIFFITH, *Tell el Yahûdiyeh*, pp. 1-21, 38-53, pls. i, ii [A-E], iii, iv, xi-xvi; DU BUISSON, *Compte rendu sommaire d'une mission à Tell el-Yahoudiyé* in *Bull. Inst. Fr. Arch. Or.* xxix, pp. 155-77, pls. ii-vii; see NAVILLE, *Les fouilles du Delta pendant l'hiver de 1887* in *Rec. de Trav.* x. 50-6. Plans of site, GRIFFITH, op. cit. pl. ix [left]; PETRIE, op. cit. pl. ii; HAYTER LEWIS, *Tel-el-Yahoudeh* in *Trans. S.B.A.* vii, plate opposite p. 178; DU BUISSON, op. cit. pl. i.

HYKSOS CAMP.

See PETRIE, op. cit. pp. 1-2, 3-8, 9, pl. v; GRIFFITH, op. cit. pp. 49-50. Sections and views, PETRIE, op. cit. pls. iii, iv A [top left].

TEMPLE OF RAMESSES II. (Destroyed.) In north-east part of Camp-enclosure.

Red granite colossal double-statue, Rameses II and Rē' (?), id. ib. pls. xvi [right], xvi A [top left], cf. p. 8; text on back, NAVILLE and GRIFFITH, op. cit. pl. ii [c], cf. pp. 9-10, 41.

Colossal statue of Rameses II, originally beside a gateway, id. ib. frontispiece and pl. ii [D], cf. p. 9.

Column of Merneptah, PETRIE, op. cit. pls. xvi [left], xvi A [top middle]; DU BUISSON, op. cit. pl. vi [2], p. 164 [lower right]; see NAVILLE and GRIFFITH, op. cit. p. 41.

TEMPLE OF RAMESSES III. (Destroyed.) In west part of Camp-enclosure.

See id. ib. pp. 10, 41.

Limestone block; text, id. ib. pl. ii [A], cf. p. 10.

Columns.

Base of alabaster column, in Cairo Mus.; text, E. BRUGSCH, *On et Onion* in *Rec. de Trav.* viii. 5; see MASPERO and ROEDER, *Führer* (1912), p. 54 [544]. (Another base is in Alexandria Mus. 38, see BRECCIA, *Alexandria ad Aegyptum* [1922], p. 152.)

Base of red granite column, DU BUISSON, op. cit. pl. vi [3], p. 164 [lower left]; text, BRUGSCH, *An den Herausgeber* in *Ä.Z.* ix. 87 [upper]; part, PETRIE, op. cit. pl. xxviii [left], cf. p. 30 [43].

Three limestone pillars; texts, BRUGSCH, op. cit. in *Ä.Z.* ix. 87 [lower].

Enamelled Chamber of Palace (P).

Decorative tiles with rosettes, cartouches of Ramesses III, and foreign captives, in various museums. In Cairo Mus.: fragments including head of negro, E. BRUGSCH, op. cit. in *Rec. de Trav.* viii, pls. i, ii, cf. pp. 3-4; Asiatic, GAYET, *Du rôle des faïences dans l'architecture égyptienne* in *Gazette des Beaux Arts* (1894), p. 57; see MASPERO, *Guide* (1914), pp. 501 [5127], 501-2 [5133-6]. In Brit. Mus.: fragments including Asiatic, HAYTER LEWIS, op. cit. in *Trans. S.B.A.* vii, pls. i-vi opposite pp. 180 ff; see *Guide to the Fourth, Fifth and Sixth Egyptian Rooms* (1922), pp. 146-7. In Berlin Mus.: Asiatics, Nos. 7944, 7945, 7947, MEYER, *Darstellungen der Fremdvölker*, 648, 649; inscribed fragments, *Aeg. Inscr. Mus. Berlin*, ii. 332 [middle], 334, cf. *Ausführ. Verzeichnis* (1899), p. 117 [c]. In Louvre: Asiatic, GAYET, op. cit. p. 55; see BOREUX, *Guide-Catalogue Sommaire* (1932), ii, p. 592.

Other fragments discovered later, PETRIE, op. cit. pl. xvi A [right, and bottom left], cf. pp. 8, 17.

TOWN AND TEMPLE OF ONIAS. Temp. Ptolemy VI Philometor to 71 A.D. Outside north-east corner of Camp-enclosure.

See id. ib. pls. xxiv-xxvii, cf. pp. 19-27. Plan, id. ib. pls. xxii, xxiii.

MAIN CEMETERY. Dyn. XII, Hyksos Period, Dyn. XVIII, XIX, XXII-XXVI, and Ptolemaic. East of Camp-enclosure and partly within it.

See NAVILLE and GRIFFITH, op. cit. pp. 50-1, pls. x, xi, xvi [middle]; PETRIE, op. cit. pp. 10-19, pls. iv A [right]-xiii, xiv A [bottom]. Plan showing position, id. ib. pl. xxii [lower].

Pottery coffin of Men , temp. Tuthmosis III, in Brussels, Musées Royaux du Cinquanteaire, E. 4348, id. ib. pls. xiv, xiv A [top right], xv [middle], cf. pp. 16-17; texts, SPELEERS, *Rec. des Inscr. Ég.* 68-9 [283].

JEWISH CEMETERY. On edge of desert.

See NAVILLE and GRIFFITH, op. cit. pp. 13-15, 51-2, pl. xvi [bottom].

DESERT CEMETERY. Dyn. XX. East of last.

Tumuli of basalt blocks, see id. ib. pp. 15-17, 42-9, pls. xii-xvi [top].

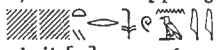
Coffins of . . . tirsunay , and two others, Graeco-Roman, one in Cairo Mus.; texts, id. ib. pl. ii [E], pp. 16-17.

Miscellaneous.

(From Tell el-Yahûdiya, but exact provenance unknown.)

Remains, Dyn. II-IV and Dyn. XII, including cylinder of Amenemhêt III, and fragment of statue of Ameny (?), Chief of prophets, temp. Amenemhêt III, PETRIE, *Hyksos and Israelite Cities*, pl. i, cf. p. 14.

Block with remains of text of festivals, Amenemhêt II, in Cairo Mus.; texts, DARESSY, *Notes et Remarques* in *Rec. de Trav.* xiv. 168 [lvii].

Busts from seated figures, Dyn. XII or XIII, PETRIE, op. cit. pl. iv A [left], cf. p. 14.

Part of offering-table, Middle Kingdom, found in house in village, NAVILLE and GRIFFITH, op. cit. pl. ii [B], cf. pp. 9, 40.

Inscribed block of Sethos I forming base of model of a temple or Heliopolis, found in 1875 west of Camp-enclosure, in Gorrige Collection, New York, GORRINGE, *Egyptian Obelisks*, pl. xxxii opposite p. 70 ('from village near Cairo'); plan of model, and sides with inscriptions, E. BRUGSCH, op. cit. in *Rec. de Trav.* viii, pls. iii, iv, pp. 8-9; see BREASTED, *Anc. Rec.* iii, §§ 244-6.

Kneeling statue, temp. Sethos II; title of King, NAVILLE and GRIFFITH, *op. cit.* p. 10, note 1.

Block of Ramesses III, built into house in village, DU BUISSON, *op. cit.* in *Bull. Inst. Fr. Arch. Or.* xxix, p. 174, fig. 36.

Block with Horus-name of Ramesses VII, found in village, now in Cairo, Institut français, *id. ib.* p. 174, fig. 37.

Bronze statuette of Osorkon I, found at Shibîn el-Qanâtîr, now in Turin Mus., LANZONE, *Descrizione di una statuette di Usarakan I* in *Atti della R. Accademia di Torino*, xi, Dec. 1875, pl. i, cf. pp. 467-70; GONINO, *A Bronze Statuette of Osorkon I, in the Collection of Professor Lanzone* in *P.S.B.A.* vi, plate opposite p. 200, cf. 205-6; MASPERO, *Hist. Anc. des Peuples de l'Orient, Les Empires*, 158; PETRIE, *A History of Egypt*, iii (1923), p. 241, fig. 98; BISSING, *Denkmäler, Text* to 58 [fig.].

Red granite pedestal with relief of King Aupweth kneeling and men worshipping, Dyn. XXIII, in Cairo Mus., NAVILLE and GRIFFITH, *op. cit.* pl. i, cf. pp. 10, 50; cartouches, NAVILLE, *Les fouilles du Delta pendant l'hiver de 1887* in *Rec. de Trav.* x. 53.

Black granite block with Horus-name of unknown King Userpehti 𓂏𓂏 ; name, BIRCH, *Varia* in *Ä.Z.* x. 122 [middle] (attributed to Sesonchis I); DARESSY, *Notes sur les XXII^e, XXIII^e et XXIV^e dynasties* in *Rec. de Trav.* xxxv. 135-6 [vi]; see GAUTHIER, *Le Livre des Rois*, iii, p. 312, note 4.

Statue of Hor 𓂏 , good name Psammethek 𓂏𓂏 , Overseer of fighting-ships on the ocean, holding naos containing goddess Bubastis, temp. Psammetikhos II, PETRIE, *Hyksos and Israelite Cities*, pls. xv [top], xx, cf. pp. 18-19.

Fragment of water-clock of Alexander the Great, in Brit. Mus. 933, see *Guide, Sculpture* (1909), pp. 254-5 [948].

EL-SHÔBAK

Statue-group of Piay 𓂏𓂏 , Governor of the Southern Peoples, and his wife, Ramesside, in Cairo Mus.; text, DARESSY, *Un groupe de statues de Tell el Yahoudieh* in *Ann. Serv.* xx. 162.

NÛB ṬAḤA

Upper part of small red granite naos dedicated to Atum by Psammetikhos I, in Cairo Mus.; text, GAUTHIER, *À travers la Basse-Égypte* in *Ann. Serv.* xxiii. 170-1 [xx].

Black stone with remains of decree of Rosetta, in Alexandria Mus., see *id. ib.* 170 [xx].

Lintel with Horus-name of Philip Arrhidaeus (probably); name, JUNKER [& c.], *Bericht in Mitteil. d. Deutsch. Inst. Kairo*, i, p. 29.

EL-KHÂNKA

Clay plaque with name of Pepy I, probably from Heliopolis; text, BRUGSCH, *Thes.* 1212 [bottom left].

SIRYÂQÛS

Upper part of red granite stela, Tuthmosis IV before Atum and Rē-Ḥarakhti, built into house in village; texts, JUNKER [& c.], *op. cit.* p. 28.

MUṢṬURUD

Two quartzite monuments of Ramesses II, NAVILLE and GRIFFITH, *op. cit.* pl. xxi [10, 11], cf. p. 66.

BAHTÎM

Base of statue of Queen Nefertari, wife of Ramesses II; texts, *id. ib.* pl. xxi [13], cf. p. 66.

Fragments of historical stela, Saite, and inscribed block, id. ib. pl. xxi [12, 14], cf. p. 66.

Inscription of Zeḥo , Servant of Nubit, Overseer of the Cabinet, KAMAL, *Tarwah el-nafás fi Medīnet el-shams* (in Arabic), p. 209.

HELIOPOLIS

Capital of the XIIIth nome of Lower Egypt.

General account, KAMAL, *Héliopolis et son mur d'enceinte* in *Bull. de la Soc. Khédiviale de Géographie*, vi [6], passim.

EL-MARG

TOMB OF PETHENFI , Head of the altar in the Great Residence of the northern On (Heliopolis); Head of lakes in the Great Residence; &c. Saite.

Reliefs in Cairo Museum.¹

Fragments of scene in marshes before deceased, MASPERO, *Le Musée Égyptien*, ii, pls. xxxv [lower], xxxvii, cf. pp. 80-1 [B]; see NAVILLE, *Mound of the Jew*, and GRIFFITH, *Tell el Yahúdíyeh*, p. 68; MASPERO, *Guide* (1914), pp. 196-7 [840].

Block with a genealogy, id. *Le Musée Égyptien*, ii, pl. xxxix [upper], cf. p. 84 [A]; omitting figures, NAVILLE and GRIFFITH, op. cit. pl. xxii [A], cf. pp. 67-8.

Fowling scene, perhaps from this tomb, found at Benha, MASPERO, *Le Musée Égyptien*, ii, pl. xlii, cf. pp. 80, 86; see id. *Guide* (1914), p. 205 [877].

VARIOUS.

Block with name of Ramesses I, found at well near Sheikh Abêd, NAVILLE and GRIFFITH, op. cit. pl. xxii [B], cf. p. 69.

Stela, Ptah and Osiris, in Cairo Mus., id. ib. pl. xxi [23], cf. p. 68.

EL-KHUŞŪŞ

BULL-CEMETERY. At 'Arab el-Ṭawīl, between El-Khuşūş and Tell Ḥiṣn.

Tomb of Mnevis, temp. Ramesses II, (reburied), DARESSY, *La tombe d'un Mnévis de Ramsès II* in *Ann. Serv.* xviii. 196-210, cf. plan, p. 196, fig. 1 [B].

Fragment with cartouches of Ramesses II; text, KAMAL, *Tarwah* [&c.], p. 202.

Mnevis coffin, temp. Merneptah, in Brussels, Musées Royaux du Cinquanteaire, E. 3058; text, SPELEERS, *Rec. des Inscr. Ég.* p. 66 [277].

Statue of Mnevis naming Bay , Overseer of the seal, [temp. Siptah], in Cairo Mus.; text, NAVILLE and GRIFFITH, op. cit. pl. xxi [21 a, b, c], cf. p. 67; DARESSY, *Une statue du taureau Mnévis* in *Ann. Serv.* xviii. 75-6.

Tomb of Mnevis, temp. Ramesses VII, (about eight metres south-west of tomb of Mnevis, temp. Ramesses II), partly built from re-used blocks of Heliopolis Temple, in Cairo Mus.; texts, KAMAL, *Chapelle d'un Mnévis de Ramsès III* (sic) in *Rec. de Trav.* xxv. 30-7; DARESSY, *La Tombe du Mnévis de Ramsès VII* in *Ann. Serv.* xviii, pp. 211-17, cf. plan, p. 196, fig. 1 [A]; see GAUTHIER, *Le Livre des Rois*, iii. 203 [ii].

Limestone stela of Thoy , worshipping Mnevis, KAMAL, *Tarwah* [&c.], p. 208.

Stela of Ken , with Ahmosi, Prince, High priest of Heliopolis, before Mnevis, in Berlin Mus. 14200; texts, *Aeg. Inscr. Mus. Berlin*, ii. 100, cf. *Ausführ. Verzeichnis* (1899), p. 313.

¹ For reliefs of similar style in Louvre, see infra p. 64, and others from Memphis, *Bibl.* iii, p. 224.



Block from Mnevis tomb, temp. Apries, NAVILLE and GRIFFITH, *op. cit.* pl. xxi [22], *cf.* p. 67.

Fragment from Mnevis tomb, bull with goddesses; texts, KAMAL, *Fragments de monuments provenant du Delta* in *Ann. Serv.* v. 199-200 [iii].

Heart-scarab of Mnevis-bull, in Toledo Mus., U.S.A., SPIEGELBERG, *A Heart Scarab of the Mnevis Bull* in *J.E.A.* xiv, p. 12, and pl. iv [2] opposite p. 7.

VARIOUS.

Fragments, some with cartouches of Ramesses II, Ramesses III, and Nektanebos I (Nekht-neb-f), NAVILLE and GRIFFITH, *op. cit.* pl. xxi [15-19], *cf.* p. 66.

Sandstone kneeling statue of Sahnūfer  called Nebma'etrē-nakht , Vizier (?), holding naos containing hawk, Dyn. XX; texts, *id. ib.* pl. xxi [20 a-d], *cf.* pp. 66-7.

Stela of Ipia , Fuller of the temple of Rē', Dyn. XX, KAMAL, *Tarwah* [&c.], p. 199; see *id. op. cit.* in *Rec. de Trav.* xxv, p. 29, note 2.

Colossal head, and capital, *Descr. de l'Égypte, Ant.* v, pl. 27 [1, 2], *cf. Texte*, x, p. 493.

TELL HİŞN

Great Enclosure

Plan, *Descr. de l'Égypte, Ant.* v, pl. 26 [1]; WILKINSON MSS.* xvii. J. 7; *L. D.* i. 55 [lower left].

TEMPLE OF SETHOS I.

See PETRIE, *Heliopolis* [&c.], pp. 1-7, pls. ii [lower]-xi. Plans and section, *id. ib.* pls. i, ii [upper].

Porter's Lodge at East Gateway.

Limestone jambs of Ramesses II, *id. ib.* pl. iii [lower right], *cf.* p. 6 [13].

West Gateway.

Fragments with cartouches of Ramesses II and III, GRIFFITH, *Tell el Yahūdiyeh* (in NAVILLE, *Mound of the Jew*), pl. xxi [8, 9], *cf.* p. 65.

Obelisk of Sesostris I (still standing).

Four faces, BURTON, *Excerpta Hiero.* xxviii; *L. D.* ii. 118 h; HAY*, 29812, 17-21; east, south, and part of north faces, *Descr. de l'Égypte, Ant.* v, pl. 26 [2-4], *cf. Texte*, x, pp. 491-3; two faces, BURTON MSS.* 25634, 21; WILKINSON MSS.* iv. 20-1 [left]; east face, KIRCHER, *Oedipi Aegyptiaci* (1653), iii. 333; north face, SHAW, *Travels or Observations* [&c.] (1738), plate opposite p. 412; ROSELLINI, *Mon. Stor.* xxv [1]; south face, CLARKE, *Travels in Various Countries* (1814), Pt. 2, Sect. 2, plate opposite p. 102; GORRINGE, *Egyptian Obelisks*, pl. xli [left] opposite p. 124; JÉQUIER, *L'Architecture*, i, pl. 11; WIEDEMANN, *The Excavations at Abusir, Egypt* in *Smithsonian Report* (1904), pl. i; part of one face, RIFAUD, *Voyage*, 102 [text at top right]; view, TRÉMAUX, *Parallèles des Édifices anciens et modernes* [&c.], pl. 50 [right] (called 'Obélisque de Memphis'); HOSKINS MSS.* i. 156; views are to be found in many books of travel.

From neighbourhood of Obelisk.

Fragments of red granite obelisks, one of Tuthmosis III and Ramesses II, and another of Amenophis II or Tuthmosis IV, found south-east of Obelisk, in Cairo Mus. 17013, PETRIE, *Heliopolis*, pls. iv-v [1-26], *cf.* pp. 5-6; KUENTZ, *Obélisques* (Cat. Caire), pp. 25-8, figs. 26-31.

Three heads of statues, two Dyn. XVIII, one Dyn. XXVI, found near last, PETRIE, *op. cit.* pl. vi, *cf.* p. 6.

Block from small black granite shrine of Ramesses II, in Berlin Mus. 2084, *L. D.*

Text, i, p. 5 [bottom]; texts, *Aeg. Inschr. Mus. Berlin*, ii. 210, cf. *Ausführ. Verzeichnis* (1899), p. 118.

Various.

Jambs of south gateway, Tuthmosis III, SHARPE, *Eg. Inschr.* 2 Ser. 41 [top left]; BRUGSCH, *Recueil*, x [23 a, b]; WILKINSON MSS.* xiii. 93; part of text, SETHE, *Urk.* iv. 568 (182) B.

Blocks from wall-scenes of Ramesses II, PETRIE, op. cit. pl. v [27-9], cf. p. 6.

Stela, Ramesses II dedicating obelisk to Rē'-Harakhti, in Glasgow Mus., id. ib. pl. viii [6], cf. p. 7.

Block from tomb of Atemhotp , Priest, Lector in the temple of Rē', New Kingdom, with part of ceremonies before mummy at tomb, re-used in west end of Enclosure, now in Glasgow Mus., id. ib. pls. vii [top], viii [4], cf. p. 6.

Scene of deceased receiving offerings from son and daughter, from tomb of Kha'em-wēset , Royal scribe, Overseer of the Granaries, New Kingdom, id. ib. pl. ix [19], cf. p. 7.

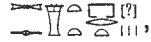
Fragment of alabaster (canopic?) jar of Princess Thesubaste-perut , daughter of Osorkon II, id. ib. pl. viii [9].

Fragments naming Amenophis III (scarab), Amenophis IV, Sethos I, Sethos II (tile), Ramesses V, Sesonchis III, Apries, and Nektanebos II (Nekht-har-ḥebi) (lower part of statue), all in Glasgow Mus., id. ib. pl. viii [1-3, 5, 7, 8, 10-12].



Two small fragments, New Kingdom, id. ib. pl. vii [right], cf. p. 6.

Fragments from tombs, probably Dyn. XXVI, id. ib. pl. ix [20, 21], cf. p. 7.

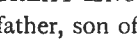
NORTHERN PART OF GREAT ENCLOSURE.

Bas-relief of a divine father, son of 'Ankhenrē' , with marsh-scene before deceased, Saite, in Cairo Mus., GAUTHIER, *À travers la Basse-Égypte* in *Ann. Serv.* xxi, pl. ii [lower], cf. pp. 32-3; names of parents, KAMAL, *Rapport sur les fouilles* [&c.] in *Ann. Serv.* x. 154 [iv].

BRICK BUILDING OF ZOSER NETERKHET, in middle of Great Enclosure. Dyn. III.

Fragments, Zoser and Princesses Intkaes  and Hetepḥernebti , found by SCHIAPARELLI (1903-6), now in Turin Mus., WEILL, *Monuments nouveaux des premières dynasties* in *Sphinx*, xv. 11-18. One fragment, King seated, PETRIE, op. cit. pl. iii [lower left], cf. p. 4.

Tombs of the High priests of Heliopolis, Dyn. VI.

Against eastern external face of Great Enclosure.

MERU , Scribe of the royal archives; High priest.

Plan and section, BARSANTI, *La nécropole des Grands Prêtres d'Héliopolis sous l'Ancien Empire* in *Ann. Serv.* xvi, pp. 213-14, figs. 1, 2. Texts of walls and sarcophagus, DARESSY, ib. in *Ann. Serv.* xvi, pp. 195-8.

SEBEKY , Overseer of the Cabinet; High priest.

Plan, BARSANTI, op. cit. p. 216, fig. 3. Texts from walls and sarcophagus, DARESSY, op. cit. 198-204.

SEBEKY , good name BY , Scribe of the royal archives in the Presence in On; High priest.



Plan, BARSANTI, op. cit. p. 218, fig. 4. Texts from walls and sarcophagus, DARESSY, op. cit. 204-9.

KHUEÑHOR , First under the King; High priest.



Plan, BARSANTI, op. cit. p. 219, fig. 5. Texts from walls, DARESSY, op. cit. 209-11.

VARIOUS.

Obelisk of Neheri , Overseer of the Estate, temp. Pepy I, in Cairo Mus. 17003, KUENTZ, *Obélisques* (Cat. Caire), pl. iv, p. 10; texts, DARESSY, op. cit. 212 [3°].

Two obelisks of Sheshi , also called Neferseshemseshet  or S'ankhptah-Pepy , Royal scribe of Heliopolis, Dyn. VI, in Cairo Mus. 17001-2, KUENTZ, op. cit. pls. ii, iii, pp. 7-10; texts, DARESSY, op. cit. 211-12 [1°, 2°].

Small obelisk of Theth , Scribe of the royal archives, Dyn. VI, in Cairo Mus. 17004, KUENTZ, op. cit. pl. iv, p. 11; text, DARESSY, op. cit. 212 [4°].

Offering-tables of Iry , of Nefer-it , Prophet of Osiris in On, and of a Royal favourite; texts, id. ib. 212 [5°, 6°, 7°].

House. About Dyn. XXIII.

North of Great Enclosure near west wall of town.

Plan, PETRIE, op. cit. pl. vii [lower]. View, id. ib. pl. ix [22].

Objects found, id. ib. pl. ii [lower], cf. pp. 6-7.



EL-MAṬARÎVA

Tombs.

(For Saite Tombs, see addenda, infra p. 270.)

RA'MOSI , Lector; Head of food and drink in the Great Residence. Dyn. XXV-XXVI.

Texts on lintel and jambs, GAUTHIER, *À travers la Basse-Égypte* in *Ann. Serv.* xxi. 200-1, cf. 198-203 with plan.

THEST(I)-WEḤEBRĒ'  (var. ) Divine father. Dyn. XXVI.

See id. *Une tombe d'époque saïte à Héliopolis* in *Ann. Serv.* xxvii, pp. 1-4, 15-18, with figs. 1, 2.

Funeral chamber and canopic vases, in Cairo Mus.; texts, id. ib. pp. 4-14, with fig. 3.

Various.

Fragment of alabaster offering-table of Pepy II, in Cairo Mus. 18556; cartouche, BISSING, *Steingefässe* (Cat. Caire), p. 114.

'EZBET EL-ZEITÛN

Canopic jars of Sebknakht , Divine father of Atum of On, from Post New Kingdom tomb; texts, KAMAL, *Un tombeau à Zeitoun* in *Ann. Serv.* iv. 95.

MANSHÏYET EL-ṢADR

Stela, year 8 of Ramesses II, from his temple at Heliopolis, in Cairo Mus.; texts, id. *Stèle de l'an VIII de Ramsès II* in *Rec. de Trav.* xxx. 214-18; see MASPERO, *Guide* (1914), p. 168 [661].

QUBBET TAUFÍQ

Sandstone architrave of Setnakht, Dyn. XX, found built into gateway; texts, GRIFFITH, *Tell el Yahdâdyeh* (in NAVILLE, *Mound of the Jew*), pl. xxi [1], cf. p. 65.

MISCELLANEOUS¹

(From Heliopolis, but exact provenance unknown.)

Statues.

Statue of Tetu , Ruler of the Residence, early Middle Kingdom (?), in Berlin Mus. 8432, *Aeg. und. Vorderasiat. Alterthümer*, pl. 12 [left], cf. *Text*, p. 7; *Ausführ. Verzeichnis* (1899), p. 82, Abb. 15; WORRINGER, *Ägyptische Kunst*, pl. 28; text, *Aeg. Inschr. Mus. Berlin*, i. 148.

Base of statue, with name of Amenemhēt I (?), in Cairo Mus., EVERS, *Staat aus dem Stein*, ii, pl. ii [34], cf. p. 95 [637].

Base of altar or statue, with text of Sesostri I, in Berlin Mus. 7720; texts, *Aeg. Inschr. Mus. Berlin*, i. 140, cf. *Ausführ. Verzeichnis* (1899), p. 78.

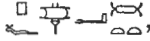

Statue-group, Ramesses II, Merneptah, and Osiris; texts, GRIFFITH, op. cit. pl. xxi [4 a-e], cf. p. 65.

Double-statuettes of Nekhtmin , Elder of the Queen's House, with wife, New Kingdom, in Berlin Mus. 4422; texts, *Aeg. Inschr. Mus. Berlin*, ii. 50, cf. *Ausführ. Verzeichnis* (1899), p. 141.

Lower part of black granite kneeling statue of Pefteu'au-Neith , Chief physician, &c., temp. Apries, possibly from here, in Brit. Mus. 83; texts, SHARPE, *Eg. Inschr.* 1 Ser. 111; PIEHL, *Saitica* in *Ä.Z.* xxxi. 88; see *Guide*, Sculpture (1909), p. 223 [805]; GAUTHIER, *Le Livre des Rois*, iv. 112 [xxx].

Fragment of basalt statue, Saite; text, GRIFFITH, op. cit. pl. xxi [2], cf. p. 65.

Red granite colossal royal statues, in Vatican Mus. 10, 12, 14, MAHAFFY, *A History of Egypt* (1899), pp. 72, 76, 100, figs. 18, 19, 26; see GAUTHIER, op. cit. iv, p. 241 [K], with note 2. No. 12, Ptolemy II Philadelphus; texts, SETHE, *Urk.* ii. 71 (16) A; MARUCCHI, *Il Museo Egizio Vaticano*, 29-30. No. 14, Arsinoë II, wife of Ptolemy II; texts, SETHE, *Urk.* ii. 71-2 (16) B; MARUCCHI, op. cit. 30-1; part, BISSING, *Sur une statue de la collection Barracco* in *Rec. de Trav.* xvii, p. 106 note 5; cartouche of Ptolemy from belt, and titles of Arsinoë from base, BRUGSCH, *Thes.* 1450 [75] (said to come from Sais). No. 10, unknown queen, possibly Philotera, daughter of Ptolemy I Soter I; text, SETHE, *Urk.* ii. 72 (16) C; see MARUCCHI, op. cit. 28-9; GAUTHIER, op. cit. iv, pp. 221-2 note 4.

Lower part of black stone double-statue with alabaster base of Hepemhab , Divine father in the Temple of Rē', and 'Ankhesenēsi , Songstress of Rē'-Harakhti, Ptolemaic, GAUTHIER, *Un groupe ptolémaïque d'Héliopolis* in *Rev. Égypt. Nouv. Sér.* ii, fasc. 3-4 (1924), pp. 2-3, 7, 9.

Stelae.

Stela, year 47 of Tuthmosis III, commemorating building of Temple-enclosure of Heliopolis, in Berlin Mus. 1634, L. D. iii. 29 b, cf. *Text*, i, p. 6; texts, SETHE, *Urk.* iv. 832 (234); *Aeg. Inschr. Mus. Berlin*, ii. 114, cf. *Ausführ. Verzeichnis* (1899), p. 132.

Stela, inscribed on both sides, Amenophis IV and family adore the Aten, the back usurped by Haremhab, with Parē-em-hab , High priest of the Temple of Rē', with hymn below, in Cairo Mus. 34175, LACAU, *Stèles du Nouvel Empire* (Cat. Caire), pl. lxxv, pp. 214-16; texts, DARESSY, *Notes et Remarques* in *Rec. de Trav.* xvi. 123-4 [cix]; titles of Queen, Princess Meketaten, the Aten, and Parē-em-hab, LEGRAIN, *Répertoire*, Nos. 289, 325.

Lower part of stela of Tataia , Songstress of Amūn, with sons, before Mnevis-bull, temp. Ramesses II, in Louvre C. 292, BÉNÉDITE, *La Formation du Musée Égyptien au Louvre*, p. 281 [fig.]; see BOREUX, *Guide-Catalogue Sommaire* (1932), i. 140.

¹ For dispersed blocks, originally from Heliopolis, found in Cairo and other parts of the Delta, see Index. For obelisks, &c., now in Rome, see later volume of this Bibliography.

Stela of [Amen]mosi , Dyn. XIX, in Cairo Mus. 34146, LACAU, op. cit. pl. lix, p. 194; texts, DARESSY, *Notes et Remarques* in *Rec. de Trav.* xiv. 38 [lviii].

Stela, year 14 of Sesonchis III, mentioning his son Bekennif ; texts, id. *Le fils aîné de Chéchanq III* in *Ann. Serv.* xvi. 61.

Stela of Uzaharmehent , Royal acquaintance; text, KAMAL, *Tarwah el-nafús fi Medînet el-shams* (in Arabic), plate between pp. 180-1.

Various.

Two blocks, head of King wearing crown of Lower Egypt, and titles of King of Upper and Lower Egypt, early Old Kingdom, possibly from here, in New York, Metropolitan Mus. 11. 150. 30-1, H. E. W[INLOCK], *Bas-reliefs from the Egyptian Delta* in *N. Y. Metro. Bull.* March 1917, pp. 64-5, cf. id. ib. June 1919, pp. 144-5; CAPART, *Documents pour servir à l'Étude de l'Art Égyptien*, i, pl. 2.

Small obelisk of Antef , Lector, Regulator of a Guild, First Intermediate Period, in Cairo Mus. 17010, KUENTZ, *Obélisques* (Cat. Caire), pl. vi, p. 17.

Block of Amenophis II, formerly in garden of café; cartouche, GRIFFITH, *Tell el Yahúdtýeh* (in NAVILLE, *Morind of the Jew*), pl. xxi [3], cf. p. 65.

Block naming Princess Merytaten, daughter of Amenophis IV; text, MASPERO, *Notes sur quelques points de Grammaire et d'Histoire* in *Á.Z.* xix. 116 [c, 3rd block].

Grey granite bas-relief, coronation of Sethos I, in Brussels, Musées Royaux du Cinquantième, E. 407, CAPART, *Recueil de Mon. Ég.* xxxix, cf. description of plates; id. *Les Antiquités Égyptiennes des Musées Royaux* [&c.], fig. 7 opposite p. 57; texts and heads, SHARPE, *Eg. Inscr.* 2 Ser. 30 [left] (then in private collection in Alexandria); texts, SPELEERS, *Rec. des Inscr. Ég.* 64 [263].

Block of Ramesses II; text, L. D. *Text*, i, p. 5 [near bottom].

Block, Ramesses II running, in Cairo Mus., KEES, *Der Opfertanz des ägyptischen Königs*, pl. iii, Abb. 5, p. 277 [39].

Blocks of Ramesses II; texts, EDGAR, *Notes from my Inspectorate* in *Ann. Serv.* xiii. 282-4 [1-13].

Sandstone fragment of obelisk or jamb, probably temp. Ramesses II, possibly from here, in Florence Mus. 2602; text, BEREND, *Principaux Monuments du Musée Égyptien de Florence*, 97; SCHIAPARELLI, *Museo Archeologico di Firenze*, pp. 427-8 [1680].

Block of Sethos II; text, MASPERO, op. cit. 116 [c, 2nd block].

Fragments with erased cartouches, GRIFFITH, op. cit. pl. xxi [5-7], cf. p. 65.

Sphinx of Psammetikhos I, possibly from here, in Alexandria Mus.; texts, DARESSY, *Inscriptions hiéroglyphiques* [&c.] in *Ann. Serv.* v. 126 [xxxix]; see GAUTHIER, *Le Livre des Rois*, iv. 77 [xlvi].

Dish of Neferebré-em-akhet , Overseer of the Royal Harîm, temp. Psammetikhos II, probably from here, in Berlin Mus., SCHÄFER in *Amtliche Berichte*, xxix, No. 7, pp. 183-4, Abb. 110.

Two quartzite sphinxes (headless) of Apries, possibly from here, in Alexandria Mus.; texts, DARESSY, op. cit. 127 [xl].

Fragment of canopic jar of Ha'a'-ebré-tharefneferu , Royal acquaintance, temp. Apries, (bought at Heliopolis, Coll. Faerber of Gera); text, WIEDEMANN, *Miscellanea* in *P.S.B.A.* xiii. 273 [upper].

Lintel with reliefs of preparation of lilies,¹ from tomb of Pairi-kep (?) , good

¹ For fragments of similar style from tomb of Thonüfer , in Cairo and Alexandria Museums, see Memphis, Kôm el-Fakhri, *Bibl.* iii, p. 224, and from tomb of Pethenfi, supra p. 59. See also supra p. 5.

name Psammethek-mery-Neith , High priest, Prophet of Buto and Nekhbet, Dyn. XXVI, perhaps from here, in Louvre, BÉNÉDITE, *La cueillette du lis et le 'lirinson'* in *Monuments Piot*, xxv, pls. iv-vi, cf. pp. 1-28 with fig. 1; BOREUX, *Guide-Catalogue Sommaire* (1932), i, pl. xxiv, cf. pp. 195-6.

Offering-table of 'Anenen , Chief priest of the Temple of Rē', Late Period, in Cairo Mus. 23144, KAMAL, *Tarwah* [&c.], p. 184; id. *Tables d'Offrandes* (Cat. Caire), pl. xxxvi, p. 111.

Offering-table of Rē'-hēt , Chief divine father of Atum, Ptolemaic, in Cairo Mus. 23138, id. *Tarwah* [&c.], p. 182; id. *Tables d'Offrandes* (Cat. Caire), pl. xxxiv, pp. 107-8.

EL-GEBEL EL-AḤMAR

Graffiti, Ramesside, &c., DARESSY, *Graffiti de la montagne Rouge* in *Ann. Serv.* xiii. 45-7.

Three fragments in quarry, one with name of Ḥori , probably Vizier, Dyn. XIX or XX; texts, BORCHARDT, *Miszellen* in *Ä.Z.* xlvi. 161.

CENTRAL PART



A. ATHRIBIS TO EL-BARĀD'A

BENHA WITH TELL ATRĪB (ATHRIBIS)

For positions on survey maps of certain finds on this site, see ENGELBACH, *The Treasure of Athribis (Benha)* in *Ann. Serv.* xxiv. 180. Plan and views, *Descr. de l'Égypte, Ant.* v, pl. 27 [3-6, 9], cf. *Texte*, x, p. 494; plan of site, WILKINSON MSS.* xvii. j. 10. Description, NESTOR L'HÔTE MSS.* 20396, 356.

CACHE OF TREASURE, Dyn. XXVI-XXX. In Cairo Museum.

ENGELBACH, op. cit. pp. 181-5 and four plates.

LIMESTONE TOMB OF PEFTUAMŪN , good name THAEM-ḤORIMU , Overseer of the Royal Harim; Overseer of the Two Treasuries. Saite-Ptolemaic.

GAUTHIER, *Sur une tombe récemment découverte à Athribis du Delta* in *Monuments Piot*, vol. xxv, pp. 171-88, with figs. 1-7.

Sarcophagus; text, id. ib. p. 180.

Miscellaneous.

(From Benha, but exact provenance unknown.)

Uninscribed grey granite statue in cloak, probably temp. Amenemhēt III, in Brit. Mus. 1237, EVERS, *Staat aus dem Stein*, i, pl. 98; HALL, *Two Middle Kingdom Statues in the British Museum* in *J.E.A.* xvi, pls. xxv, xxvi, cf. pp. 167-8; BLACKMANN in ROSS, *The Art of Egypt through the Ages*, p. 136 [4]; see *Guide, Sculpture* (1909), p. 83 [288].

Stela of Prince Meryrē , son (?) of Sekhemkarē, Dyn. XIII, in Brit. Mus. 1346, BRUGSCH, *Thes.* 1455 [84] (copied in Alexandria in 1874); BUDGE, *A History of Egypt*, iii, plate opposite p. 86; *Hiero. Texts* [&c.], Pt. iv, pl. 22; *Guide to the Egyptian Collections* (1909), pl. xxviii, cf. p. 223; (1930), p. 330, fig. 176; text, WIEDEMANN, *Eine Stele des Königs Ra-Sechem-Ka* in *Études . . . dédiées à Leemans*, 27-8; see *Guide, Sculpture* (1909), p. 80 [277]; GAUTHIER, *Le Livre des Rois*, ii, pp. 4 [iii], 5 [viii] with note 2.

Black granite monument with figure of sacred serpent of Athribis, Amenophis III, in

Cairo Mus., MARIETTE, *Mon. Div.* pl. 63 [b]; text, LEGRAIN, *Répertoire*, No. 240; BRUYÈRE, *Mert-Seger à Deir el Médineh*, p. 220; see MASPERO, *Guide* (1914), p. 136 [490].

Red granite statue-group, Ramesses II and two gods; texts, GAUTHIER, *À travers la Basse-Égypte* in *Ann. Serv.* xxi. 212-13.

Red granite lion of Ramesses II, in Brit. Mus. 857; text, L. D. *Text*, i, p. 221 [middle lower]; NESTOR L'HÔTE MSS.* 20396, 356; cartouches, BRUGSCH, *Thes.* 1223 [middle upper]; id. *Recueil*, x [2]; see *Guide*, Sculpture (1909), pp. 163-4 [593].



Blocks of Ramesses II with magical reliefs and inscriptions, in Cairo Mus., DARESSY, *Bas-reliefs d'Athribis* in *Ann. Serv.* xvii, pp. 186-93, with figs. 1-4.

Block with cartouches of Ramesses II, BRUGSCH, *Recueil*, x [1].

Block (usurped) of Ramesses II and Prince Merneptah, with Sêth erased by latter, in Cairo Mus., ENGELBACH, *A Monument of Prince Merneptah from Athribis (Benha)* in *Ann. Serv.* xxx, pls. i, ii, pp. 197-202.

(For obelisks of Ramesses II, &c., see infra p. 70.)

Two jambs and two lintels from tomb of Mentemtawi , Ramesside; texts, GAUTHIER, op. cit. in *Ann. Serv.* xxi. 18-21.

Circular offering-table of Hor  or , Overseer of prophets of Kentekhtai of Kemwër, Post New Kingdom, in Cairo Mus. 23091, KAMAL, *Tables d'Offrandes* (Cat. Caire), pl. xix, pp. 74-9; texts, DARESSY, *Notes et Remarques in Rec. de Trav.* xiv. 178-80 [lxiii].

Frieze from naos with alternate cartouches of Sabacon and Wehebrê' (Dyn. XXIV or XXV), re-used in Roman portico, now in Cairo Mus., WILKINSON MSS.* xviii. 23 [near top]; cartouches, GAUTHIER, *Le Livre des Rois*, iii. 412 [1], iv. 16 [xv]; see MASPERO, *Guide* (1914), p. 217 [974].

Column of Apries; texts, EDGAR, *Notes from my Inspectorate* in *Ann. Serv.* xiii. 281.

Naos of Kemwër of Athribis, dedicated by Amasis, in Cairo Mus. 70011, ROEDER, *Naos* (Cat. Caire), pl. 12 [a], pp. 38-42, cf. pls. 54 [c], 75 [a, b], 76 [a, b].

Grey granite royal head, and grey granite royal statue, after Dyn. XXVI, in Brit. Mus. 633, 1209, *Guide*, Sculpture (1909), p. 243 [895, 897], with figs. on pp. 243, 244; head (No. 633), *Guide to the Egyptian Collections* (1930), p. 384, fig. 210.

Fragment with cartouches of Teos, SHARPE, *Eg. Inscr.* 2 Ser. 43 [1]; WILKINSON MSS.* ix. 129 [right], xviii. 23 [top]; see DARESSY, *Le roi Téos à Athribis* in *Ann. Serv.* xvii. 42.

Fragment of bas-relief in blue stone with remains of cartouches of Nektanebos II (Nekht-har-hebi), in Brussels, Musées Royaux du Cinquanteaire, E. 4877 B, SPELEERS, *Rec. des Inscr. Ég.* p. 88 [336].

Fragment of squatting statue of Khensorudi (?) , Late Period (bought at Benha in 1882), in Cairo Mus. 719; texts, BORCHARDT, *Statuen und Statuetten* (Cat. Caire), iii, p. 56.

Black granite statue of Zeḥo-p-shed , Chief door-keeper of Har-Kentekhtai of Kemwër, holding stela with Horus on the crocodiles, temp. Philip Arrhidaeus, in Cairo Mus., LACAU, *Les Statues 'guérisseuses' dans l'ancienne Égypte* in *Monuments Piot*, vol. xxv, pl. xv, cf. pp. 189-93 with figs. 1-3; LOUKIANOFF, *Le dieu Ched* [&c.] in *Bull. Inst. Ég.* xiii, pl. iii [13], cf. p. 78; texts and sketch, DARESSY, *Statue de Zedher le Sauveur* in *Ann. Serv.* xviii. 114-58. Missing fragment of base found later, id. ib. in *Ann. Serv.* xix. 66-8.

Trilingual decree of asylum, year 18 of Ptolemy XI Alexander I, in Cairo Mus. 31089, SPIEGELBERG in MASPERO, *Le Musée Égyptien*, ii, pl. viii, p. 22; omitting scene at top, SPIEGELBERG, *Die Demotischen Inschriften* (Cat. Caire), pl. iii, and pp. 20-2.

Base of granite statue of Mer-Har-yotf , High priest of Athribis, probably

Ptolemaic; text, BRUGSCH, *Thes.* 1414-15 [a]; DARESSY, *Fragment de socle de statue provenant d'Athribis* in *Ann. Serv.* xvi. 54-5.

Remains of bas-relief with Kentekhthai and another god, Ptolemaic or Roman, in Alexandria Mus., GOLÉNISCHEFF'S description of plates of objects in his Collection, p. 6.

KAFR MANÂQIR, south end of Benha.

Dorsal pillar of statue of Nektanebos I (Nekht-neb-f), in Cairo Mus.; texts, DARESSY, *Un débris de statue de Nectanébo II* in *Ann. Serv.* xix. 136.

KÔM EL-AḤMAR

Historical granite stela, Libyan campaign, year 5 of Merneptah (lost in canal during transit to Cairo but recovered in 1927), LEFEBVRE, *Stèle de l'an V de Méneptah* in *Ann. Serv.* xxvii, pls. i, ii, pp. 21-3, 30; texts on both sides, MASPERO, *Notes sur quelques points de Grammaire et d'Histoire* in *Ä.Z.* xxi. 65-7 [xxxv].

ṬÛKH EL-MALAQ

Black granite statuette of Shu with bull's head, in Cairo Mus. 42193; text on back, DARESSY, *Le dieu de Toukh el Malaq* in *Ann. Serv.* xvii. 45.

QAHA

Two fragments of a red granite obelisk of Merneptah, probably from Heliopolis, in Cairo Mus. 17025; texts, id. *L'obélisque de Qaha* in *Ann. Serv.* xix. 131-2; KUENTZ, *Obélisques* (Cat. Caire), pp. 51-2, with fig. 50; see DARESSY, *Notes et Remarques* in *Rec. de Trav.* xx. 85 [clxiii].

EL-BARÂD'A

Stela, Ptolemaic, probably from Tell Atrîb (Athribis), in Cairo Mus.; texts, GAUTHIER, *À travers la Basse-Égypte* in *Ann. Serv.* xxi. 39.

B. ZÂWYET RAZÎN TO GIREIS

ZÂWYET RAZÎN

Fragment of architrave with cartouche of Ramesses II, and black granite statue of Pedeḥor-meten (?) , Overseer of prophets of Bubastis, temp. Psammetikhos I; texts, DARESSY, *À travers les koms du Delta* in *Ann. Serv.* xii. 193, 194-5; see GRIFFITH, *Tell el Yahûdiyeh* (in NAVILLE, *Mound of the Jew*), p. 60.

GIREIS

Two blocks, one of Ptolemy I Soter I, found at Kôm el-Dosha; remains of texts, DARESSY, op. cit. 184.

ASHMÛN

Basalt block with remnant of New Kingdom inscription mentioning Tunip, re-used for ritual-text about Dyn. XXX, in Cairo Mus.; texts, id. *Une inscription d'Achmoun* [&c.] in *Ann. Serv.* xvi. 222-30.

WEST PART

TERENUTHIS TO LETOPOLIS

KÔM ABÛ BILLO (TERENUTHIS)

Block with cartouches of Ramesses II; cartouches, EDGAR, *Notes from my Inspectorate* in *Ann. Serv.* xiii. 281 [upper left].

TEMPLE. (Destroyed.) Ptolemaic.

See GRIFFITH, *op. cit.* pp. 61-3.

Re-used blocks.

Blocks of Ptolemy I Soter I, Ptolemy II Philadelphus, and Penamün [= xx (13)], *id. ib.* pl. xx [8-15], pp. 62-3; blocks of Ptolemy I and Penamün, in *Brit. Mus.* 651-3, see *Guide*, Sculpture (1909), pp. 256 [952, 951], 209 [760]. For Penamün, see GAUTHIER, *Le Livre des Rois*, iii, p. 403 [9] with note 3.

Relief of Ptolemy I Soter I, in Oxford, Ashmolean Mus., BISSING, *Denkmäler, Text* to 119 [2nd fig.].

Fragment of block of Necho II, at door of mosque, GRIFFITH, *op. cit.* pl. xx [4], *cf.* pp. 60-1.

Two inscribed fragments, Ptolemy I Soter I (?), *id. ib.* pl. xx [5, 6].

WARDÂN

Coffin of Psammethek , Saite or Ptolemaic, in Cairo Mus., GRÉBAUT, *Le Musée Égyptien*, i, pl. xix, pp. 16-17; see MASPERO, *Guide* (1914), p. 305 [3262 bis].

EL-QATṬA

Middle Kingdom Tombs.

CHASSINAT, GAUTHIER and PIERON, *Fouilles de Qattah in Mém. Inst. Fr. Arch. Or.* xiv, *passim*. Plan of site, *id. ib.* pl. i.

TOMB OF NEHA , Mayor. (No. 2.)

Plans, sections, and views, *id. ib.* pls. iv-viii [1, 2].

Sepulchral Chamber.

Texts, *id. ib.* pp. 33-70, *cf.* pl. vi [3].

Stela of Sekhmet-hotp, Overseer of sealers; texts, *id. ib.* pp. 72-3.

VARIOUS.

Fragment of stela, found behind east wall of tomb of Neha; remains of text, *id. ib.* p. 76.

Stela of Sebkhotp , found in tomb No. 9; texts, *id. ib.* p. 74.

AUSÏM (LETOPOLIS) or

TEMPLE OF HORUS. (Entirely destroyed.) Saite and Nektanebos I (Nekht-neb-f).

Lower part of red granite statue of Necho II, dedicated by Psammetikhos II; text on back, KAMAL, *Quelques fragments provenant d'Oussim in Ann. Serv.* iv. 92 [upper].

Grey granite fragment, Achoris, in Cairo Mus.; text, *id. ib.* 92 [lower].

Limestone and black granite blocks of Nektanebos I, &c.; texts, SPIEGELBERG, *Varia in Rec. de Trav.* xxvi. 147-8.

Three black granite blocks of Nektanebos I, one with geographical procession; texts, GAUTHIER, *À travers la Basse-Égypte in Ann. Serv.* xxiii. 171-3.

Two black granite block of Nektanebos I, with nomes of Lower Egypt, from base of Temple, found in Sûq el-Şâ aḥ, Cairo, *id. Une liste de nomes à Létopolis in Ann. Serv.* xxxii, pp. 78-80 with plate.

Various inscribed blocks, Saite, in village of Kafr Sîdi (?) Mûsa, KAMAL, *op. cit.* in *Ann. Serv.* iv. 93-4.

IV. CAIRO

Plans, *Descr. de l'Égypte, État moderne*, i, pl. 26, with index in *Texte*, xviii, 2^e partie, pp. 137-288; PAUTY, *La défense de l'ancienne ville du Caire* [&c.] in *Bull. Inst. Fr. Arch. Or.* xxxi, plans 1-8 between pp. 140 and 173.

MONUMENTS AND RE-USED BLOCKS FOUND IN THE CITY¹**Old and Middle Kingdoms.**

Base of statue of Khephren, probably from Giza, found in Old Cairo (El-Fustât), in Cairo Mus.; texts, DARESSY, *Antiquités trouvées à Fostat* in *Ann. Serv.* xviii. 275 [1^o].

Fragment of recumbent sphinx of Pepy I, found in Haret el-Rum (Ferid Pasha), east of Mosque el-Mu'aiyad [*Descr.* viii. 213, M. 5-6; BAEDEKER, F. 5], in Cairo Mus. 541, BORCHARDT, *Statuen und Statuetten* (Cat. Caire), ii, pl. 90, p. 90.

False door of woman Zen-wen , in former Palace in Qaṣr el-Dubâra [BAEDEKER, c. 5], *L. D. Text*, i, p. 19 [bottom]; texts, SETHE, *Urk.* i. 72-3 (49).

Quartzite jamb of Sesostri I, probably from Heliopolis, in house opposite Coptic church [*Descr.* G. 8; BAEDEKER, F. 4]; text, DARESSY, *Inscriptions hiéroglyphiques trouvées dans le Caire* in *Ann. Serv.* iv. 101.

Quartzite jamb (Late Period), enumerating endowments attributed to Sesostri, probably from Heliopolis, used as threshold of bookshop near Mosque el-Azhâr [*Descr.* vii. 57, K. 4; BAEDEKER, G. 4]; text, DARESSY, *op. cit.* 102.

Part of quartzite architrave of Sesostri I or Nektanebos I (Nekht-neb-f), and quartzite block with five rows of divinities, Saite, both used as thresholds near Mosque el-Azhâr [*Descr.* vii. 57, K. 4; BAEDEKER, G. 4]; texts, DARESSY, *Notes sur des pierres antiques du Caire* in *Ann. Serv.* ix. 139-40.

Block with name of Princess Neferu-Ptaḥ , daughter of Amenemḥet III, found in Darb el-Asfar, near Shâri' el-Gamâliya [*Descr.* vii. 321, G. 5; BAEDEKER, G. 4]; text, DARESSY, *Remarques et Notes* in *Rec. de Trav.* x. 142 [v]; see GAUTHIER, *Le Livre des Rois*, i. 337 [xcvii c]; DARESSY, *Les inscriptions antiques trouvées au Caire* in *Bull. Inst. Ég.* iii Sér. No. 10, p. 148.

Two blocks, one with cartouches of Sebekḥotep III or IV, the other with titles and cartouches of Amosis, built into houses in 'Atfet el-Khayashi near Bâb el-Futūḥ [*Descr.* E. 6*; BAEDEKER, G. 3*]; texts, DARESSY, *op. cit.* in *Ann. Serv.* xii. 285 (called Ramesses I).

Hyksos Period.

Grey granite offering-table, Middle Kingdom, dedicated to Sēth, and usurped by Apophis II, originally from Ṣân el-Ḥagar (Tanis), Heliopolis, or Memphis, in Cairo Mus. 23073, MARIETTE, *Mon. Div.* pl. 38; KAMAL, *Tables d'Offrandes* (Cat. Caire), pp. 61-2; MASPERO, *Hist. Anc. des Peuples de l'Orient, Les Premières Mêlées*, fig. on p. 59; id. *Guide* (1914), p. 145, fig. 45, cf. p. 144 [506]; see GAUTHIER, *op. cit.* ii. 142 [iii].

New Kingdom.

Black granite jamb of Tuthmosis III, probably from Heliopolis, found near Citadel [*Descr.* R-S. 4; BAEDEKER, F-G. 6-7], *Descr. de l'Égypte, Ant.* v, pl. 24 [1],

¹ The references in square brackets are to maps in *Descr. de l'Égypte, État Moderne*, i, pl. 26, with Index, *Texte*, xviii, 2^e partie, and BAEDEKER, *Egypt* (1929), plan between pp. 36 and 37. An asterisk implies that the place is not marked on the map quoted.

cf. *Texte*, x, p. 488; SHARPE, *Eg. Inscr.* 2 Ser. 34 [A] (copied by BONOMI); text, SETHE, *Urk.* iv. 830-1 (233) A, B, C.

Column made up of fragments of columns of Amenophis III, usurped by Merneptah and Setnakht, probably from Heliopolis, in Mosque el-Turkemâni at Bâb el-Baḥr [*Descr.* vi. 261, E. 12; BAEDEKER, E. 3*], WILKINSON MSS.* iv. 83, 83 verso; cartouches, DARESSY, *Notes sur des pierres antiques du Caire* in *Rec. de Trav.* xxxv. 46; see GAUTHIER, op. cit. iii, pp. 121 note 3, 153 note 4.

Grey granite column of Amenophis III usurped by Merneptah and Setnakht, probably from Heliopolis, not Memphis, found in an 18th-century house in Cairo and bought by SALT, in *Brit. Mus.* 64, YORKE and LEAKE, *Remarks on some Egyptian Monuments in England*, pl. vii, fig. 16; BUDGE, *Egyptian Sculptures in the British Museum*, pl. xxiii; see *Guide*, Sculpture (1909), p. 117 [419].

Grey granite base of statue (?) of Amenophis IV, seen by SHARPE and copied by BONOMI in a garden in Cairo (probably originally from El-Till, see *infra* p. 235), in *Brit. Mus.* 1000; text, SHARPE, *Eg. Inscr.* 2 Ser. 48, ll. 6-9; BRYANT and READ, *An Inscription of Khuenaten* in *P.S.B.A.* xv. 209-11; PERRING, *On some fragments from the ruins of a temple at El Tell* in *Trans. Roy. Soc. Lit.* 2 Ser. i (1843), pl. ii [middle] between pp. 140 and 141; WILKINSON MSS.* xvii. F. d 4 [middle], xviii. 71 [upper] ('brought from Reramoun to I. of Roda and given to Mr. Harris'); cartouches, *Guide*, Sculpture (1909), p. 123 [435].

Part of large quartzite stela of Ḥaremḥab, probably from Heliopolis, used as threshold, found near Citadel [*Descr.* R-S. 4; BAEDEKER, F-G. 6-7], in Cairo Mus.; text, DARESSY, *Inscriptions hiéroglyphiques trouvées dans le Caire* in *Ann. Serv.* iv. 103-4 [4°]; LEGRAIN, *Notes d'inspection* in *Ann. Serv.* viii. 58; titles, id. *Répertoire*, No. 323; see DARESSY, op. cit. in *Bull. Inst. Ég.* iii. Sér. No. 10, p. 149.

Angle of sandstone door with cartouche of Ḥaremḥab (?), probably from Heliopolis, found opposite Mosque of Salahdar [*Descr.* vii. 247, 1. 6; BAEDEKER, G. 3*], in Cairo Mus.; text, DARESSY, op. cit. in *Ann. Serv.* iv. 103 [3°].

Offering-table of Sethos I, probably from Heliopolis, found in 'Atfet el-Biraqdar outside the Bâb el-Futûḥ [*Descr.* vii. 385, D. 5; BAEDEKER, G. 3*], in Cairo Mus. 23090, KAMAL, *Tables d'Offrandes* (Cat. Caire), pl. xix [upper], pp. 73-4; texts, id. *Une nouvelle table d'offrandes de Séti I* in *Ann. Serv.* ii. 95-6.

Portion of statue of Ramesses II, in Florence Mus. 7667; cartouches of Sethos II on back, PELLEGRINI, *Glanures* in *Rec. de Trav.* xx. 99 [33].

Red granite block with cartouches of Ramesses II, found before house in Shâri' Abu-Lifa, KAMAL, *Rapport sur les fouilles* [&c.] in *Ann. Serv.* x. 152 [1].

Block with remains of text of a door of Ramesses II (?), used as mortar and found near Bâb Zuwêla [*Descr.* viii. 249, M. 6; BAEDEKER, G. 5], WILKINSON MSS.*vi. 112 [bottom].

Black granite obelisk of Ramesses II, re-used by Merneptah and Sethos II, perhaps usurped from Middle Kingdom, probably from Tell Atrîb (Athribis), used as threshold in a house in Cairo, in Berlin Mus. 12800, *Aeg. und Vorderasiat. Alterthümer*, pl. 116, cf. *Ausführ. Verzeichnis* (1899), pp. 124-5 with fig. 26; texts, *Aeg. Inscr. Mus. Berlin*, ii. 28-34; see *Amtliche Berichte*, xvii (1896), vii.

Fragment of granite obelisk of Ramesses II, usurped by Sethos II, probably from Tell Atrîb (Athribis), found in Old Cairo (El-Fustât), in Cairo Mus.; text, DARESSY, *Antiquités trouvées à Fostat* in *Ann. Serv.* xviii. 276 [2°].

Fragment of statue of Nefertari, wife of Ramesses II, in Brussels, Musées Royaux du Cinquanteaire, E. 2459; texts, SPELEERS, *Rec. des Inscr. Ég.* 66 [272].

Part of red granite column, Merneptah before two divinities, and beginning of text of

year 5 concerning Libyan invasion, from court of Ministry of Public Instruction [*Descr.* c. 6], (seen by WILKINSON at the 'Kroomfish manufactory'¹ in 1832), in Cairo Mus., WILKINSON MSS.* xvii. k. 8, xxii. 28; text, MASPERO, *Notes sur quelques points de Grammaire et d'Histoire* in *Ä.Z.* xix. 118 [h].

Stela, Amen-rē and Ramesses III, in Brussels, Musées Royaux du Cinquanteaire, E. 3046; texts, SPELEERS, op. cit. 68 [279].

Quartzite block of Ramesses III, probably from Heliopolis, used as threshold in Mosque Sidi el-Belkeni, in Shâri' Bein el-Sayârig [*Descr.* v. 92, E. 6; BAEDEKER, G. 3]; text, DARESSY, op. cit. in *Ann. Serv.* iv. 104 [5^o].

Lower part of obelisk of Ramesses IV, probably from Heliopolis, found in foundations of a house in Cairo, now in Cairo Mus. 17026, KUENTZ, *Obélisques* (Cat. Caire), pl. xix, pp. 53-4; texts, DARESSY, op. cit. 104-5 [6^o]; see MASPERO, *Guide* (1914), p. 156 [576].

After Dyn. XX.

Stela, year 16 of Siamûn, found in Old Cairo (El-Fustât), now in Cairo, Collection Collège Saint-Joseph des Frères des Écoles Chrétiennes; text, MUNIER, *Un achat de terrains au temps du roi Si-Amon* in *Rec. d'Études Égyptologiques dédiées à la Mémoire de Champollion*, 361-3.

Part of lid of black granite sarcophagus of P-ar-kep , Persian, used as threshold in Mosque Kikhya at north end of Shâri' Abdîn [*Descr.* vi. 293, K. 13; BAEDEKER, E. 4]; text, DARESSY, *Notes sur des pierres antiques du Caire* in *Ann. Serv.* ix. 140. (For sarcophagus itself, see supra p. 48.)

Fragment of kneeling statue of Semtu-tefnakht , Overseer of Upper Egypt, holding naos of goddess, temp. Psammetikhos I, seen in Shâri' Wagh el-Birka; text, SPIEGELBERG, *Varia* in *Ä.Z.* liii. 112 [12]; id. *Beiträge zu den demotischen Rylands Papyri* in *Rec. de Trav.* xxx. 176 [74].

Block from under-side of capital of column, two scenes, Psammetikhos II before Atum, and followed by *ka* with standard, found in Citadel [*Descr.* R-S. 4; BAEDEKER, F-G. 6-7], HAY*, 29847, 56 [top left].

Basalt column of Apries, originally from Şa el-Ḥagar (Saïs), in Mosque el-Ghamri and then in house in Shâri' Amîr el-Giyûsh, in Cairo Mus., JÉQUIER, *L'Architecture*, ii, pl. 7 B [5]; texts, GAUTHIER, *À travers la Basse-Égypte* in *Ann. Serv.* xxii. 200. (For two others, see Şa el-Ḥagar and Ganâg, supra pp. 48, 49.)

Granite obelisk of Apries, probably from Heliopolis, found near former canal-bridge Qanţara el-Gedîda [*Descr.* v. 260, G. 8; BAEDEKER, F. 3*], NIEBUHR, *Reisebeschreibung nach Arabien und andern umliegenden Ländern* (1774), i, pl. xxxvi [B], cf. p. 167.

Fragment, Apries, used as threshold of a house in Cairo, L. D. iii. 274 g, cf. *Text*, i, p. 6.

Inscribed blocks, one of Apries, probably from Memphis, the other of Amasis, both re-used in Citadel [*Descr.* R-S. 4; BAEDEKER, F-G. 6-7], ROSELLINI, *Mon. Stor.* cliii [2, 3], cf. *Text*, iv. 202, 203.

Libation-table of Peftu'au-Neith , Chief steward, temp. Apries, standing in niche in Mosque of Bêbars Gashinkir [*Descr.* vii. 294, G. 5; BAEDEKER, G. 4]; text, WIEDEMANN, *Inschriften aus der saïtischen Periode* in *Rec. de Trav.* viii. 64 [3].

Red granite stela, year 3 of Amasis, from Elephantine, used as threshold in the palace inhabited by Kléber near the Ezbekiya [BAEDEKER, E. 4], in Cairo Mus.; text, DARESSY, *Stèle de l'an III d'Amasis* in *Rec. de Trav.* xxii. 2-3; see MASPERO, *Guide* (1914), p. 198 [849] (said to be year 1).



¹ Established by Muḥammad 'Alî presumably in Shâri' el-Khurunfish [*Descr.* vii. 314, G-H. 6; BAEDEKER, F-G. 4], see WILKINSON, *Modern Egypt and Thebes*, i, p. 265.

Sandstone block from a temple of Amasis, probably at Memphis, used as threshold of entrance to a court in Bûlâq quarter [BAEDEKER, C-D. 2-3]; text, KAMAL, *Sur un monument d'Amasis qui se trouve à Boulaq* in *Ann. Serv.* iii. 93.



Granite block with offering-scene of Amasis, in Mosque Sultân-Hasan [*Descr.* i. 1, s. 6; BAEDEKER, F. 6], formerly used as threshold; texts, DARESSY, *Notes sur des pierres antiques du Caire* in *Rec. de Trav.* xxxv. 45-6 [3].

Block with scene of Amasis with naos followed by *ka* (CHAMPOLLION and ROSELLINI give cartouche of Apries in error), probably originally from Memphis, found in Citadel [*Descr.* R-S. 4; BAEDEKER, F-G. 6-7], CHAMPOLLION, *Mon.* ccccliii [1]; ROSELLINI, *Mon. Stor.* cliii [1]; YOUNG, *Hieroglyphics*, pl. 42 [iii] 'at Joseph's Hall, Cairo'; WILKINSON MSS.* i. 134; see GAUTHIER, *Le Livre des Rois*, iv, p. 122 [xl], with note 2.

Fragment of shrine (?) of Amasis, found near 'Souq e' Semmak' (i.e. Fish-market) [*Descr.* ii. 221, T. 7; BAEDEKER, F. 6], WILKINSON MSS.* vi. 203.

Grey granite sarcophagus of Hepmen , good name Khenstefnakht , Dyn. XXVI, (known as 'The Lover's Fountain'), in Mosque of Ibn Tulûn [*Descr.* ii. 146, V. 8-9; BAEDEKER, E. 7], in Brit. Mus. 23; view in Mosque, AINSLIE, *Views in Egypt* (drawings by LUIGI MAYER), 1804, plate opposite p. 26, cf. second plate after p. 48; exterior and interior, *Descr. de l'Égypte, Ant.* v, pls. 24 [2-10], 25, cf. *Texte*, x, pp. 488-90; exterior, ALEXANDER, *Egyptian Monuments*, 3rd, 12th, 15th, and 16th plates; sides, SHARPE, *Eg. Inscr.* 1 Ser. 44-5; one side, NIEBUHR, op. cit. i, pl. xxx; see *Guide, Sculpture* (1909), pp. 229-30 [826].

Fragment of statuette with name of Dhutardais , Dyn. XXVI, found near tomb of Sheikh el-Arba'ini in Saida Zenab [*Descr.* iii. 158, U. 12; BAEDEKER, D. 6]; texts, SELIM HASSAN, *Inscription sur un socle de statuette* in *Ann. Serv.* xxviii. 3-5.

Black basalt sarcophagus (without lid) of Heniati , good name Khnemebré-men , Chief lector, Saite, found on bank of Nile at Bûlâq [BAEDEKER, c. 1-4], in Brit. Mus. 86, *Descr. de l'Égypte, Ant.* v, pl. 23, cf. *Texte*, x, pp. 487-8; ALEXANDER, op. cit. 5th plate (said to be from Minûf); texts, PIEHL, *Inscr. Hiéro.* 3 Sér. xl-xli [v]; see *Guide, Sculpture* (1909), p. 230 [828].

Two granite blocks, one, Saite, in Mosque el-Dardîr, south of Mosque el-Azhâr [*Descr.* viii. 222, L. 5; BAEDEKER, F. 5*], the other, Ramesses II, in house near; texts, DARESSY, *Notes sur des pierres antiques du Caire* in *Rec. de Trav.* xxxv. 45 [1, 2].

Fragment of sandstone statue of Achoris, found near Cairo; text, PIEHL, *Varia* in *Ä.Z.* xxvi. 114 [liv].

Fragments of black granite sarcophagus of Nektanebos I (Nekht-neb-f), some in Cairo Mus.; texts, DARESSY, op. cit. in *Ann. Serv.* iv. 105-9 [7°]; one fragment, from Mosque Sangar el-Gâuli [BAEDEKER, E. 6-7], KAMAL, *Note sur un fragment de Naos* in *Ann. Serv.* ii. 129-30; another fragment from lid, found in a house, DARESSY, *Remarques et Notes* in *Rec. de Trav.* x. 142 [vii]; see id. *Les inscriptions antiques trouvées au Caire* in *Bull. Inst. Ég.* iii Sér. No. 10, p. 151.

Naos of Neith, dedicated by Nektanebos I (Nekht-neb-f), in Cairo Mus. 70020, ROEDER, *Naos* (Cat. Caire). pl. 16 [a], pp. 57-8.

Block from a capital, Nektanebos I (Nekht-neb-f) holding sphinx, found in Citadel [*Descr.* R-S. 4; BAEDEKER, F-G. 6-7], CHAMPOLLION, *Mon.* ccccliii [2]; ROSELLINI, *Mon. Stor.* cliv [1], cf. *Texte*, iv, p. 225, § 3; HAY*, 29847, 56 [top right].

(For blocks of Nektanebos I (Nekht-neb-f), found in Sûq el-Şâlah [*Descr.* i. 20, R. 6; BAEDEKER, F. 6*], see Ausîm (Letopolis), supra p. 68.)

Pair of black basalt obelisks of Nektanebos II (Nekht-ḥar-ḥebi), from the Delta, perhaps from Tell Baqlîya (Hermopolis Parva) to be set up in front of a mosque in 18th

century and seen by NIEBUHR as threshold in a mosque in the Citadel [*Descr.* R-S. 4; BAEDEKER, F-G. 6-7], in Brit. Mus. 523, 524, see *Guide*, Sculpture (1909), p. 247 [919, 920], and GAUTHIER, *Le Livre des Rois*, iv. 178 [xxx], No. 524, ALEXANDER, op. cit. (1805-7), 8th plate; *Descr. de l'Égypte. Ant.* v, pl. 21, cf. *Texte*, x, pp. 486-7; north and west faces [3 and 4 of *Descr.*], TOMLINSON, *On the Two Obelisks of Black Basalt in the British Museum* in *Trans. Roy. Soc. Lit.* ii, plate opposite p. 457 [1, 2], cf. pp. 460-1; incomplete, NIEBUHR, op. cit. i, pl. xxxvi [A]. No. 523, ALEXANDER, op. cit. 10th plate; *Descr. de l'Égypte. Ant.* v, pl. 22, cf. *Texte*, x, p. 487; one face [4 of *Descr.*], *Guide to the Egyptian Collections* (1909), pl. xlvi; (1930), p. 395, fig. 218; sketch with position of cartouches, YORKE and LEAKE, *Remarks on some Egyptian Monuments in England*, pl. vii, fig. 17.

Black basalt block from sarcophagus with titles of a prophet of Isis of Bahbit, Dyn. XXX, found in Mosque el-Ashraf [*Descr.* vii. 194, K. 6; BAEDEKER, F. 4], in Cairo Mus.; text, DARESSY, op. cit. in *Ann. Serv.* xii. 284.

Granite block of Alexander II from door of naos, found in foundations of a school at Bûlâq, now in Cairo Mus.; text, id. ib. 286.

(For 'Satrap's Stela' of Alexander II, in Mosque Sheikhûn [*Descr.* ii. 121, v. 7; BAEDEKER, F. 6], see supra p. 49.)

Green basalt stela with remains of trilingual decree of Canopus (almost illegible), year 9 of Ptolemy III Euergetes I, used as threshold in Mosque of Amîr Khûr [*Descr.* iii. 263, s. 13; BAEDEKER, D. 6*], in Louvre C. 122, BURTON, *Excerpta Hiero.* liv, lv; see *Descr. de l'Égypte. Texte*, ix. 314-17; DUBOIS, *Description des Antiquités Égyptiennes . . . Collection Mimaut* (1837), pp. 40-1; SETHE, *Urk.* ii. 125 (30) L; BOREUX, *Guide-Catalogue Sommaire* (1932), i, p. 89.

Statue of Khenti (?) $\overline{\Delta}(\?)^{\circ}$, Priest, holding astronomical instrument, Ptolemaic, probably from Medînet el-Faiyûm, found in Old Cairo (El-Fustât), in Cairo Mus.; text, DARESSY, *Antiquités trouvées à Fostat* in *Ann. Serv.* xviii. 276-8 [3°].

(For lid of coffin of Tshentehe \Rightarrow , Ptolemaic, in court of School of Medicine, Qaṣr el-'Aini [BAEDEKER, C. 7], see *Bibl.* iii, p. 57.)

Inscribed block, Horus on the crocodiles, *Descr. de l'Égypte. Ant.* v, pl. 70 [7-11].

SOUTH OF OLD CAIRO (EL-FUSTÂṬ)

REMAINS OF TEMPLE. Between the Nile and the railway to Ḥelwân, opposite Iṣṭabl 'Antar.

Sandstone sphinx of Amasis; text, GOLÉNISCHEFF, *Lettre à M. G. Maspero sur trois petites trouvailles égyptologiques* in *Rec. de Trav.* xi. 98 [bottom].

Block with remains of relief and cartouche, id. ib. 99 [top].

ON THE CAIRO-SUEZ ROAD

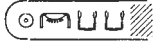
Graffito of Nubkaurê' . . . , High priest of Heliopolis, temp. Amenemhêt II, at Wâdi el-'Anqabiya el-Rawyâna. at kilometre 22 from Cairo, TOWNSEND, *A XIIIth Dynasty inscription near the Cairo-Suez road* in *Ann. Serv.* xxxiii, p. 3, cf. pls. i, ii.

V. BETWEEN CAIRO AND EL-FAIYÛM

(ṬURA TO MAIDÛM)

EAST BANK

ṬURA AND EL-MA'ŞARA

Plan with position of numbered stelae,¹ VYSE, *Operations carried on at the Pyramids of Gizeh*, iii, plate opposite p. 93. Views, id. ib. plates opposite pp. 91 and 92; L. D. i. 50 [lower]. Description and various cartouches, BURTON MSS.* 25618, 91-2 verso.

ṬURA QUARRIES

1. Stela, year 43 of Amenemhêt III, VYSE, op. cit. iii, plate opposite p. 94 [left]; L. D. ii. 143 i, cf. *Text*, i, p. 20 [top]; see DARESSY, *Inscriptions des carrières de Tourah et Mâsarah* in *Ann. Serv.* xi. 257.
2. Stela, upper register, Amenophis II offers incense and libation to Amen-rê', Horus, Sobk, Wepwaut, Hâthor, and Bubastis, lower register, King before Ptaḥ, Osiris, Kentekhtai, Astarte, Sekhmet, Hâthor, and Buto, with text of year 4 below, VYSE, op. cit. iii, plate opposite p. 95; part of text, L. D. *Text*, i, p. 20 [middle and left]; DARESSY, op. cit. 258.
3. Stela, Amenophis III offers *uzat* to Amen-rê', Horus and Harsaphes, with text of year 1, VYSE, op. cit. iii, plate opposite p. 96; L. D. iii. 71 a; see DARESSY, op. cit. 259.
4. Stela, upper register, Amenophis III offers to destroyed divinities, lower register, King offers to Sopt (?), Anubis, Wert-Ḥekau, and Hâthor, with text of year 2 below, VYSE, op. cit. iii, plate opposite p. 97; L. D. iii. 71 b; see DARESSY, op. cit. 259.
5. Stela, double scene (effaced), Necho II offers to Neith and to Ptaḥ, with six lines text below; sketch, VYSE, op. cit. iii, plate opposite p. 98 [upper]; L. D. iii. 273 a; texts, DARESSY, op. cit. 259-60.

EL-MA'ŞARA QUARRIES

6. Stela of Neferpert $\frac{\text{𓏏}}{\text{𓏏}}$, Overseer of sealers, year 22 of Amosis, with sledge drawn by oxen at bottom, YOUNG, *Hieroglyphics*, pl. 88 [lower left]; ROSELLINI, *Mon. Stor. Text*, i, pl. xv; VYSE, op. cit. iii, plate opposite p. 99; L. D. iii. 3 a; BURTON MSS.* 25618, 93-5 [right upper], 96, 97; WILKINSON MSS.* i. 81 [upper left]; text, CHAMPOLLION, *Not. Descr.* ii. 488 [lower]; SETHE, *Urk.* iv. 24-5 (6); BRUGSCH, *Das ägyptische Troja* in *Ä.Z.* v. 92; top, WILKINSON MSS.* v. 36 [top]; sledge, CHAMPOLLION, *Mon. ccciv* [3]; ROSELLINI, *Mon. Civ.* xlvii [6]; PRISSE, *L'Art Égyptien, Texte*, p. 308; WILKINSON, *M. and C.* iii. 324 (No. 389)=ed. BIRCH, ii. 302 (No. 428); DARESSY, op. cit. 263-4.
 7. Sobk with text, and titles of Isis, VYSE, op. cit. iii, plate opposite p. 98 [lower]; head and text, CHAMPOLLION, *Not. Descr.* ii. 488 [upper]; text, DARESSY, op. cit. 264.
 8. Stela of Neferpert with same text as 6, YOUNG, op. cit. pl. 88 [lower right]; VYSE, op. cit. iii, plate opposite p. 94 [right]; L. D. iii. 3 b; WILKINSON MSS.* i. 81 [upper, middle right]; text, SETHE, *Urk.* iv. 24-5 (6); top, WILKINSON MSS.* v. 36 [middle].
 9. Stela, destroyed scenes, Ptolemy II Philadelphus and Queen Arsinoë II offering to divinities, VYSE, op. cit. iii, plate opposite p. 100.
 10. Stela, a King offers field to Hâthor and Thoth, id. ib. plate opposite p. 101; YOUNG, op. cit. pl. 89 [upper left]; WILKINSON MSS.* i. 81 [lower, middle left].
- Near 10. Cartouches of Psammetikhos II, VYSE, op. cit. iii, second plate opposite p. 102 [bottom left].

Between 10 and 11. Two stelae of Ptolemy II Philadelphus(?) and probably Arsinoë II;

¹ The numbering followed is that of VYSE.

texts, DARESSY, op. cit. 265-6; for position, see VYSE, op. cit. iii, plan opposite p. 93 (called Cleopatra and Ptolemy Soter).

11. Stela, a King (destroyed) before Theban Triad, YOUNG, op. cit. pl. 90 [top]; VYSE, op. cit. iii, first plate opposite p. 102; SPIEGELBERG, *Die Demotischen Inschriften der Steinbrüche von Turra und Mašara* in *Ann. Serv.* vi, plate and p. 221; WILKINSON MSS.* i. 81 [lower left]; texts, DARESSY, op. cit. 266.





12. Cartouches of Achoris, YOUNG, op. cit. pl. 89 [6, 7, 9, 11, 13, 14]; BRUGSCH, *Recueil*, x [15, 16, 20-22]; SPIEGELBERG, op. cit. pp. 222 [No. 2], 223 [No. 13], 224 [No. 20]; DARESSY, op. cit. 267; WILKINSON MSS.* i. 81 [upper, middle left], on 171; one cartouche, VYSE, op. cit. iii, second plate opposite p. 102 [bottom right]; *L. D. Text*, i, p. 223 [near bottom].

Fragment of stela, Thoth as baboon, YOUNG, op. cit. pl. 89 [12]; WILKINSON MSS.* i. 169 [upper left].

Stela, Nektanebos II (Nekht-ḥar-ḥebi) offers field to Thoth, Neḥem'awat, and Neferḥor, YOUNG, op. cit. pl. 88 [upper]; BURTON MSS.* 25618, 95 [left], 95 verso; WILKINSON MSS.* i. 169 [lower]; text at bottom, id. ib. xii. 167 [lower]; first line, BRUGSCH, op. cit. in *A.Z.* v. 91.

Defaced stela, Nektanebos II (?) offers field to divinity, YOUNG, op. cit. pl. 89 [upper right]; WILKINSON MSS.* i. 81 [lower, middle right].

Stone altar of Seḥetepebrē'-ankh , High priest of Ptaḥ, Dyn. XII, id. ib. xvii. f. d 7, 8 [top left].

Wooden sarcophagus of Ḥepi , Prophet of Ptaḥ, son of Senbef  and Takebto, and wooden object of Khentikher , Prophet of Ptaḥ and Thoth, born of Senbef , son of Pedemin (?) , id. ib. f. d 8 [right, and left lower].

TURA CEMETERY

Pot with name of protodynastic 'Scorpion' King from predynastic cemetery, JUNKER, *Bericht über die Grabungen . . . auf dem Friedhof in Turah* [&c.], p. 5, Abb. 4; id. *Die älteste ägyptische Königstitulatur* in *Anzeiger d. k. Akad. d. Wiss. Wien* (Phil. Hist. Kl.), 1910, plate opposite p. 128.

EL-MINYA AND EL-SHURAFÄ

See map, PETRIE and MACKAY, *Heliopolis, Kafr Ammar and Shurafa*, pl. xlvii.

ROMAN FORT, TOWN, AND CEMETERY, AND PTOLEMAIC CEMETERY FARTHER SOUTH





See ENGELBACH, in id. ib. pp. 40-5, pls. xlvii-lij.

Sphinx of a Queen, Dyn. XVIII or XX, in Cairo Mus., ENGELBACH, *Recent Acquisitions in the Cairo Museum* in *Ann. Serv.* xxxi, pl. ii [lower], cf. p. 128.

Stela, year 16 of Osorkon II, found in *sebakh*, in Cairo Mus.; texts, DARESSY, *Trois stèles de la période Bubastite* in *Ann. Serv.* xv. 140-1.

ATFÎḤ (APHRODITOPOLIS)

CEMETERY. At Minshât Sulimân, east of Atfîḥ.

FAMILY-TOMB OF PEDUSIRI , SONS SENUSERT  and PEDEḤORDENI , and grandson PEDUSIRI , good name ḤOR , all Priests. Ptolemaic.

Plan, DARESSY, *Tombeau ptolémaïque à Atfieh* in *Ann. Serv.* iii. 161.

Outer and Inner Halls.

Texts from jambs and walls, including names and titles, and Book of the Dead, id. ib. 162-75.

Astronomical ceiling; texts and sketch, id. ib. 176-9.

TOMB OF SACRED ISIS-COW HESIS $\text{𓆎} \text{𓆏} \text{𓆑}$. Ptolemaic. 187 metres from last.

See PETRIE and MACKAY, *Heliopolis, Kafr Ammar and Shurafa*, p. 38 [68], cf. pl. xl [left]; SPIEGELBERG, *Die Begräbnisstätte der heiligen Kühe von Aphroditopolis (Atfih)* in *O.L.Z.* xxiii. 258-9.

Hall.

Above door, remains of scene of offering-bringers, Thoth, &c., before cow, PETRIE and MACKAY, op. cit. pl. xli [bottom].

Doorway. Texts on jambs, KAMAL, *Fouilles à Atfih* in *Ann. Serv.* ix. 117 [bottom].

West wall. Three registers divinities, PETRIE and MACKAY, op. cit. pl. xliii.

North (rear) wall. Upper register, sacred cow dragged on sledge, lower register, six divinities, id. ib. pl. xli [top and middle].

East wall (south according to KAMAL). Three registers divinities; first, second, and remains of third, id. ib. pl. xlii; texts, KAMAL, op. cit. 116-17.

Sculptured slab with cartouche of Osorkon I, found blocking doorway, PETRIE and MACKAY, op. cit. pl. xl [bottom right].

Sarcophagus; texts, id. ib. pl. xlv; KAMAL, op. cit. 114-15.

FINDS

(From Atfih, but exact provenance unknown.)

Black granite sphinx (headless), Sebekhotp IV, in Cairo Mus.; cartouches, GAUTHIER, *Le Livre des Rois*, ii. 34 [xi].

Fragments with cartouches of Ramesses II, WILKINSON MSS.* xii. 158.

Lower part of statue of Sethos II, holding naos containing statue of Isis-Hathor, found in foundations of building south-east of village of Atfih; texts, NAGUIB, *Sur un fragment de statue de Séti II trouvé à Atfih* in *Ann. Serv.* iii. 213-14.

Stela, year 13 of Ptolemy I Soter I, probably from here, in Cairo Mus. 22180, KAMAL, *Stèles Ptolémaïques et Romaines* (Cat. Caire), pl. liii, pp. 158-9; texts, DARESSY, *Notes et Remarques* in *Rec. de Trav.* xvi. 127-8 [cxvi]; SPIEGELBERG, *Ein Denkstein auf den Tod einer heiligen Isiskuh* in *Ä.Z.* xliii. 129-32; SETHE, *Urk.* ii. 159-62 (34).

WEST BANK**MAZGHÛNA**

See map of site, PETRIE, WAINWRIGHT, and MACKAY, *The Labyrinth, Gerzeh and Mazghuneh*, pl. 1 [left].

North Pyramid. Possibly Sebekneferurê'.

See id. ib. pp. 50-3. Plan and sections, id. ib. pls. xlvii-xlix [upper].

South Pyramid. Possibly Amenemhêt IV.

See id. ib. pp. 41-50, pls. xlii-xliv. Plan and sections, id. ib. pls. xxxix-xli [upper].

MORTUARY TEMPLE, on east side of Pyramid.

See id. ib. pp. 48-9, pl. xlv. Plan, id. ib. pl. xli [lower left].

CEMETERY, temp. Tuthmosis III, within Pyramid-enclosure.

See id. ib. p. 49, pls. 1 [right], lii [lower].

VARIOUS.

Middle Kingdom hieratic ostraca, found outside wavy Enclosure wall, id. ib. pl. xli [1, 3], cf. p. 48.

Necropolis south of South Pyramid.

Dyn. V-VI, Ptolemaic, and Roman.

See id. ib. pp. 37-41, pls. xlvi, lii [upper]. Plans of Old Kingdom rock-tombs, id. ib. pl. li.

EL-DINNÂWÎYA

Limestone columns of Ramesses II in village; texts, EDGAR, *Notes from my Inspectorate* in *Ann. Serv.* xiii. 284.

PYRAMID-FIELD OF EL-LISHT

GAUTIER and JÉQUIER, *Fouilles de Licht* in *Mém. Inst. Fr. Arch. Or.* vi, passim; id. *Fouilles de Licht* in *Rev. Arch.* 3^e Sér., xxix (1896), pp. 36-70. Map of site, PERRING, *The Pyramids of Gizeh*, Pt. iii, pl. xvii; VYSE, *Operations carried on at the Pyramids of Gizeh*, iii, plate opposite p. 77; L. D. i. 43 [lower]; GAUTIER and JÉQUIER, op. cit. in *Mém. Inst. Fr. Arch. Or.* vi, pls. i, xxix; id. op. cit. in *Rev. Arch.* xxix, pl. xiii.

North Pyramid Δ $\frac{W}{H}$ $\frac{I}{6}$ Δ . *Amenemhêt I.*

(LX of LEPSIUS.)

See GAUTIER and JÉQUIER, op. cit. in *Mém. Inst. Fr. Arch. Or.* vi, pp. 87-107; LYTHGOE, *The Egyptian Expedition* in *N. Y. Metro. Bull.* April 1907, pp. 61-3, figs. 1-5; MACE, *The Egyptian Expedition* in ib. Oct. 1908, pp. 184-8, figs. 1-6; id. *Excavations at the North Pyramid of Lisht* in ib. Oct. 1914, pp. 207-22; id. *Excavations at Lisht* in ib. Pt. ii, Nov. 1921, pp. 5-19; id. ib. Pt. ii, Dec. 1922, pp. 4-18. Plan and section, id. ib. p. 5, fig. 1; GAUTIER and JÉQUIER, op. cit. in *Mém. Inst. Fr. Arch. Or.* vi, p. 87, fig. 106; section, L. D. *Text*, i, p. 213.

Foundation deposits, in New York, Metropolitan Mus., MACE, op. cit. in *N. Y. Metro. Bull.* Oct. 1908, p. 184, fig. 2; id. op. cit. in ib. Pt. ii, Nov. 1921, pp. 10-11, figs. 9-11.

MORTUARY TEMPLE, on east side of Pyramid.

See LYTHGOE, *The Egyptian Expedition* in *N. Y. Metro. Bull.* July 1907, pp. 113-17, figs. 1-6.

Block, in New York, Metropolitan Mus., *A Handbook of the Egyptian Rooms* (1911), p. 72, fig. 35.

Re-used blocks from earlier building of Amenemhêt I.

Blocks in Cairo Mus., GAUTIER and JÉQUIER, op. cit. in *Mém. Inst. Fr. Arch. Or.* vi, pp. 94-7, figs. 108-14; King as hawk before Atum [GAUTIER and JÉQUIER, p. 94, fig. 108], MACE, op. cit. in *N. Y. Metro. Bull.* Oct. 1908, p. 184, fig. 1; Horus-name of King, EVERS, *Staat aus dem Stein*, i, pl. 14.

Fragments of relief, in New York, Metropolitan Mus., *A Handbook of the Egyptian Rooms* (1911), p. 71, fig. 34.

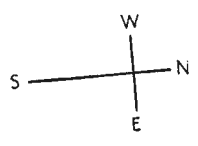
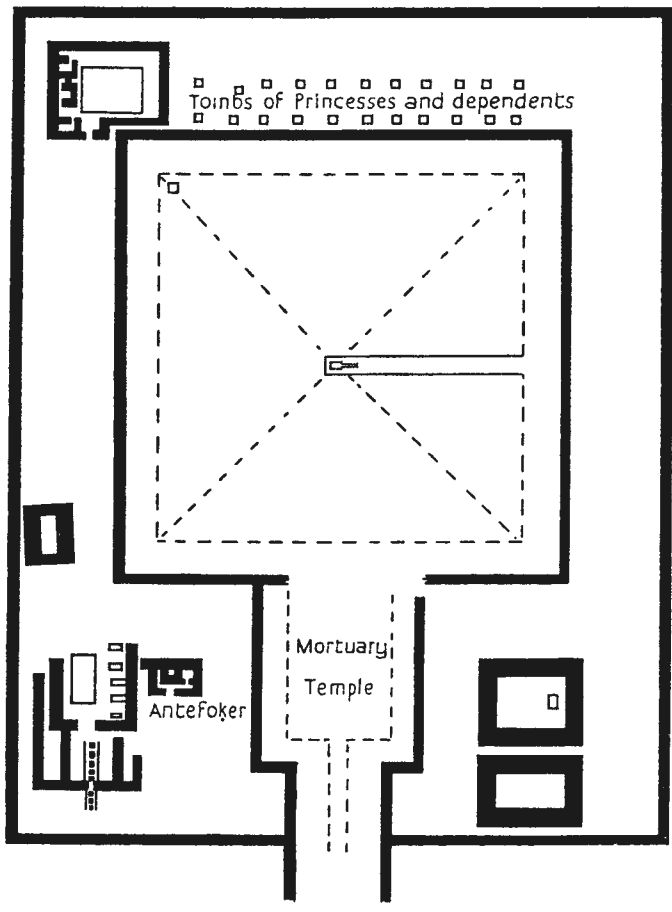
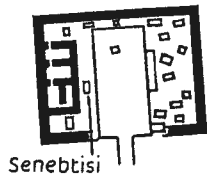

EL-LISHT. NORTH PYRAMID. AMENEMHĒT I.

From MACE in *N. Y. Metro. Bull.* Pt. II, Dec. 1922, p. 5, fig. 1, with addition supplied by New York Metropolitan Museum.

False door, in Cairo Mus., granite altar with noines, and block with King and divinities, both in New York, Metropolitan Mus., LYTHGOE, op. cit. in *N.Y. Metro. Bull.* July 1907, pp. 115-17, figs. 4-6; altar, *A Handbook of the Egyptian Rooms* (1911), p. 51, fig. 21, cf. p. 56.

PYRAMID.

View of entrance, GAUTIER and JÉQUIER, op. cit. p. 88, fig. 107, cf. pl. xxx [bottom].

Chapel at entrance.

False door, MACE, op. cit. in *N.Y. Metro. Bull.* Oct. 1908, p. 185, fig. 3; see id. *The Egyptian Expedition* in ib. May 1908, pp. 83-4, figs. 1, 2.

Old Kingdom reliefs re-used in Pyramid.

In New York, Metropolitan Museum.¹

Rigging of an Egyptian ship, MACE, op. cit. in ib. Pt. ii, Dec. 1922, p. 13, fig. 12.

Head and shoulders of a goat, id. ib. p. 13, fig. 13.

Two men leading bulls, *A Handbook of the Egyptian Rooms* (1911), p. 36, fig. 14.

Block re-used in pavement, MACE, op. cit. in *N.Y. Metro. Bull.* Oct. 1914, p. 221, fig. 15.

Tombs of Princesses.

Plan and section, id. *Excavations at Lisht* in ib. Pt. ii, Nov. 1921, p. 9, fig. 8.

Fragment with name of Princess Neferu, or possibly Neferu-sheri, found in débris, see id. ib. Pt. ii, Dec. 1922, p. 12.

Mastabas inside Pyramid-enclosure.

ANTEFOKER , Vizier; Overseer of the Pyramid-town.

Plan, GAUTIER and JÉQUIER, op. cit. in *Mém. Inst. Fr. Arch. Or.* vi, p. 98, fig. 115.

South Hall.

West wall. Remains of stela with name of Sent , id. ib. p. 99, fig. 117.

North wall. Deceased and priest sacrificing, id. ib. p. 99, fig. 118.

Finds.

Statue (broken), found in east part of mastaba; texts, id. ib. pp. 99-100, figs. 119-21.

NAKHT , Chief steward. South of last mastaba.

Statue found in débris, in Cairo Mus. 409, id. ib. p. 100, fig. 122; BORCHARDT, *Statuen und Statuetten* (Cat. Caire), ii, pl. 67, pp. 20-1; EVERS, op. cit. i, pl. 22.

MASTABA, at south-west corner of Pyramid.

Section, GAUTIER and JÉQUIER, op. cit. p. 101, fig. 123.

Fragment with three offering-bringers, id. ib. p. 103, fig. 124.

Mastabas outside Pyramid-enclosure.

PIT OF SENEPTISI .

MACE and WINLOCK, *The Tomb of Seneptisi at Lisht*, passim; see LYTHGOE, *The Egyptian Expedition* in *N.Y. Metro. Bull.* Oct. 1907, pp. 163-9, figs. 1-8.

Sepulchral Chamber.

Coffins containing jewellery, &c., and canopic box and jars, in New York, Metropolitan Mus., MACE and WINLOCK, op. cit. frontispiece, pls. vii-xxxi, xxxiii, pp. 24-8, 31-9, 59, 66, figs. 8-11, 15, 16, 18-23, 28, 33, cf. pp. 6-7, figs. 1-2; coffins and jewellery, LYTHGOE,

¹ To be published by CAROLINE RANSOM WILLIAMS.

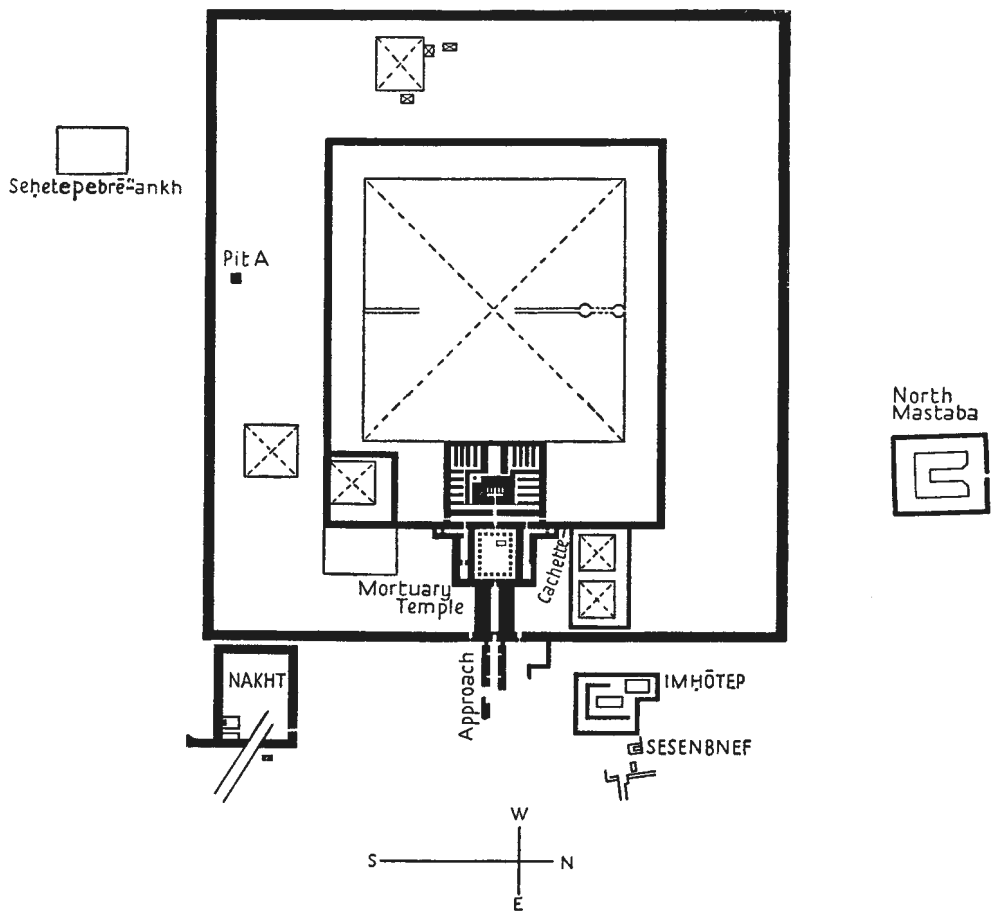

EL-LISHT. SOUTH PYRAMID. SESOSTRIS I.

Adapted from GAUTIER and JÉQUIER in *Mém. Inst. Fr. Arch. Or.* vi, pl. iii, and plan supplied by New York Metropolitan Museum.

op. cit. pp. 165-7, figs. 3-8; *A Handbook of the Egyptian Rooms* (1911), pp. 52, 55, 57, figs. 22, 24, 25.

PIT OF AMENY 

Stela of Ameny and Sit-Khonsu , and signet ring, MACE, *Excavations at the North Pyramid of Lisht* in *N. Y. Metro. Bull.* Oct. 1914, cover, and p. 220, fig. 13.

Rock-tombs. Old Kingdom. South of Pyramid.

Offering-table and stela in a forecourt, found *in situ*, LANSING, *The Museum's Excavations at Lisht* in *ib.* Pt. ii, April 1933, p. 21, fig. 20, cf. p. 22.

Various.

Fragments of two offering-tables of Amenemhēt I, base of pillar or jamb from mastaba of a priest of Amenemhēt I, statuette (uninscribed), and upper part of another, found close to Pyramid, GAUTIER and JÉQUIER, op. cit. pp. 103-4, figs. 125-30.

Head of statuette of Amenemhēt I (probably), in New York, Metropolitan Mus., found in tomb-shaft south of Approach, MACE, *The Egyptian Expedition in N. Y. Metro. Bull.* Oct. 1908, p. 186, fig. 4; *A Handbook of the Egyptian Rooms* (1911), p. 73, fig. 36.

Limestone offering-table of Nefert , King's mother, presumably mother of Amenemhēt I, re-used in house at south-west corner of Pyramid, MACE, op. cit. in *N. Y. Metro. Bull.* Pt. ii, Dec. 1922, p. 12, fig. 11.

Porphyry weight with cartouche of Sesostri I, id. op. cit. in *ib.* Oct. 1914, p. 218, fig. 9; B. M. C[ARTLAND], *Egyptian Weights and Balances* in *ib.* April 1917, p. 89, fig. 5.

Limestone weight with titles of Sesostri I, MACE, *Excavations at Lisht* in *ib.* Pt. ii, Nov. 1921, p. 17, fig. 19.

Fragment of bas-relief, and fragment from the belt of a statue, both temp. Amenemhēt III, GAUTIER and JÉQUIER, op. cit. p. 106, figs. 131-2.

Block from mastaba, preparing fowls and driving cattle, Dyn. XII, re-used in doorway of later town, MACE, op. cit. in *N. Y. Metro. Bull.* Oct. 1914, p. 219, fig. 12.

Granite statue of Mentuhotp , Overseer of the Granary, Dyn. XII, id. op. cit. in *ib.* Pt. ii, Nov. 1921, p. 14, fig. 15.

Basalt statuette of Sehetep-thau (?)  (?) on limestone table of offerings, Dyn. XII, id. *ib.* p. 13, fig. 14.

Head of female wooden statuette, Dyn. XII, LYTHGOE, op. cit. in *ib.* Oct. 1907, p. 163, fig. 2.

Block with cartouche of Ramesses II, GAUTIER and JÉQUIER, op. cit. p. 106, fig. 318.

South Pyramid . *Sesostri I.*

(LXI of LEPSIUS.)

See GAUTIER and JÉQUIER, *Fouilles de Licht* in *Rev. Arch.* 3^o Sér. xxix, pp. 39-70; LYTHGOE, *The Egyptian Expedition in N. Y. Metro. Bull.* Sept. 1908, pp. 171-3 and fig. 1; id. *ib.* July 1909, pp. 119-21, figs. 1-6; id. *ib.* Pt. ii, Feb. 1915, pp. 5-22, figs. 1-5, 7-17, 19; LANSING, *Excavations on the Pyramid of Sesostri I at Lisht* in *N. Y. Metro. Bull.* Pt. ii, July 1920, pp. 3-11, figs. 2-7; id. *The Museum's Excavations at Lisht* in *N. Y. Metro. Bull.* Pt. ii, Dec. 1924, pp. 33-43 with fig. 8; Pt. ii, March 1926, pp. 33-40; Pt. ii, April 1933, pp. 3-22, figs. 1-18. Plan, GAUTIER and JÉQUIER, *Fouilles de Licht* in *Mém. Inst. Fr. Arch. Or.* vi, pl. iii; id. op. cit. in *Rev. Arch.* pl. xiii; east part, LYTHGOE, op. cit. in *N. Y. Metro. Bull.* Pt. ii, Feb. 1915, p. 8, fig. 3; id. in *Anc. Eg.* (1915), p. 146, fig. 1; LANSING, op. cit. in *N. Y. Metro. Bull.* Pt. ii, July 1920, p. 4, fig. 1.

APPROACH.

Osiride statues of King, originally on either side.

Six found near north-east angle of outer Enclosure wall, now in Cairo Mus. 397-402; Nos. 399 and 401, GAUTIER and JÉQUIER, op. cit. in *Rev. Arch.* 3^o Sér. xxix, p. 63, fig. 22, cf. pp. 49, 65; id. op. cit. in *Mém. Inst. Fr. Arch. Or.* vi, p. 39, fig. 38, cf. p. 19; BORCHARDT, *Statuen und Statuetten* (Cat. Caire), ii, pl. 65, cf. pp. 14-16; JÉQUIER, *L'Architecture*, i, pl. 17 [1, 2]; CAPART, *L'Art Égyptien*, i, *L'Architecture*, pl. 65; No. 401, EVERS, *Staat aus dem Stein*, i, pls. 31, 32. Two more with numerous fragments, found fallen in Approach, in New York, Metropolitan Mus.; one, *A Handbook of the Egyptian Rooms* (1911), p. 77, fig. 38; the other (headless), LYTHGOE, op. cit. in *N. Y. Metro. Bull.* Sept. 1908, p. 171, fig. 3.

MORTUARY TEMPLE, on east side of Pyramid.

See LYTHGOE, *The Egyptian Expedition* in *N. Y. Metro. Bull.* July 1909, pp. 120-1, figs. 2-3; LANSING, op. cit. in ib. Pt. ii, March 1926, pp. 33-40, figs. 1-7. Plan, GAUTIER and JÉQUIER, op. cit. in *Mém. Inst. Fr. Arch. Or.* vi, p. 17, fig. 10; id. op. cit. in *Rev. Arch.* 3^o Sér. xxix, p. 54, fig. 17; LANSING, op. cit. p. 37, fig. 4; LYTHGOE, op. cit. in *N. Y. Metro. Bull.* Pt. ii, Feb. 1915, p. 8, fig. 3; id. in *Anc. Eg.* (1915), p. 146, fig. 1; LANSING, op. cit. in *N. Y. Metro. Bull.* Pt. ii, July 1920, p. 4, fig. 1.

Granite architrave with name of Sesostris I, id. ib. Pt. ii, March 1926, p. 39, fig. 6.

Relief with two offering-bringers, in New York, Metropolitan Mus., *A Handbook of the Egyptian Rooms* (1911), p. 75, fig. 37.

Two fragments with remains of offerings, in New York, Metropolitan Mus., CAPART, *Documents pour servir à l'étude de l'art égyptien*, pl. 28 [top and middle].

Another fragment, in New York, Metropolitan Mus., EVERS, op. cit. i, pl. 47.

Inscribed blocks, GAUTIER and JÉQUIER, op. cit. in *Mém. Inst. Fr. Arch. Or.* vi, p. 20, figs. 11-13.

Two blocks, offering-scene, and head of offering-bringer, in New York, Metropolitan Mus., LYTHGOE, op. cit. in *N. Y. Metro. Bull.* July 1909, p. 123, figs. 5, 6.

Bas-relief of King, presumably from here, GAUTIER and JÉQUIER, op. cit. pl. vi [lower].

Offering-table, in Cairo Mus. 23001, id. ib. pl. viii, pp. 23-6, figs. 16-20; id. op. cit. in *Rev. Arch.* 3^o Sér. xxix, p. 66, fig. 23; KAMAL, *Tables d'Offrandes* (Cat. Caire), pls. i, ii, pp. 1-3.

Ivory wand of Neferu-Ptah $\square \begin{array}{c} \uparrow \uparrow \uparrow \\ \uparrow \uparrow \uparrow \\ \uparrow \uparrow \uparrow \\ \uparrow \uparrow \uparrow \end{array}$, daughter of Amenemhêt III, found near Mortuary Temple, in Cairo Mus. 9438, and fragment of offering-table of Sesostris I, GAUTIER and JÉQUIER, op. cit. in *Mém. Inst. Fr. Arch. Or.* vi, p. 60, figs. 68, 69, cf. pp. 57-60; wand, LEGGE, *Magic Ivories of the Middle Empire* in *P.S.B.A.* xxvii, pl. viii, fig. 13, cf. p. 142; DARESSY, *Textes et Dessins Magiques* (Cat. Caire), pl. xii, p. 47.

CACHETTE, near north-west corner of Mortuary Temple.

Statues of Sesostris I, in Cairo Mus. 411-20, GAUTIER and JÉQUIER, op. cit. in *Mém. Inst. Fr. Arch. Or.* vi, pls. ix-xiii, pp. 31-8, figs. 24-5, 28-37; id. op. cit. in *Rev. Arch.* 3^o Sér. xxix, pl. xii, pp. 51-2, figs. 13-15, p. 62, fig. 21, cf. pp. 60-4; Nos. 418, 417, 416, EVERS, op. cit. i, pl. 26; Nos. 412, 419, and another, JÉQUIER, *L'Architecture*, i, pl. 16; No. 411 [GAUTIER and JÉQUIER in *Mém. Inst. Fr. Arch. Or.* vi, fig. 28], BORCHARDT, op. cit. ii, pl. 67, pp. 21-3; EVERS, op. cit. i, pls. 28, 29; No. 418 [GAUTIER and JÉQUIER, fig. 29], EVERS, op. cit. i, pl. 27; right side of throne, BORCHARDT, op. cit. ii, p. 27; No. 413 [GAUTIER and JÉQUIER, fig. 30], BORCHARDT, op. cit. ii, pl. 67, pp. 23-4; No. 419 [GAUTIER and JÉQUIER, pl. xii, fig. 31], left side of throne, BORCHARDT, op. cit. ii, pp. 27-8; Nile-god from right side, EVERS, op. cit. i, pl. 30; No. 415 [GAUTIER and

JÉQUIER, fig. 32], left side of throne, BORCHARDT, op. cit. ii, p. 25; CAPART, *L'Art Égyptien* (1909), pls. 32, 33; No. 417 [GAUTIER and JÉQUIER, fig. 33], left side of throne, BORCHARDT, op. cit. ii, p. 26; No. 416 [GAUTIER and JÉQUIER, fig. 34], texts on sides of throne, BORCHARDT, op. cit. p. 26; No. 420 [GAUTIER and JÉQUIER, fig. 35], left side of throne, BORCHARDT, op. cit. pp. 28-9; BORCHARDT and REISNER, *Works of Art*, 23; MASPERO and ROEDER, *Führer* (1912), pl. 15; No. 412 [GAUTIER and JÉQUIER, pl. xi, fig. 36], texts on sides of throne, BORCHARDT, *Statuen und Statuetten* (Cat. Caire), ii, p. 23; No. 414 [GAUTIER and JÉQUIER, fig. 37], BISSING, *Denkmäler*, 19 [b], 20; texts on sides of throne, BORCHARDT, op. cit. ii, p. 24; upper part of one statue, *Anc. Eg.* (1914), first plate after p. 144.

INNER ENCLOSURE WALL.

Decorated limestone panels with hawk in relief, name of King, imitation false door, and Nile at bottom, GAUTIER and JÉQUIER, op. cit. in *Mém. Inst. Fr. Arch. Or.* vi, pp. 9-12, figs. 4-6, and pl. vi [upper]; id. op. cit. in *Rev. Arch.* 3^e Sér. xxix, pp. 42-3, figs. 6, 7; LYTHGOE, *The Egyptian Expedition in N. Y. Metro. Bull.* Sept. 1908, pp. 170, 172, figs. 2, 4; LANSING, *The Museum's Excavations at Lisht* in ib. Pt. ii, Dec. 1924, pp. 36-8, figs. 3-7; Pt. ii, April 1933, pp. 4-5, figs. 1-3; Nile, id. ib. Pt. ii, Nov. 1933, p. 10, fig. 9, cf. pp. 8-9.

Remains of inscribed grooved columns from entrance with fragments of texts, GAUTIER and JÉQUIER, op. cit. in *Mém. Inst. Fr. Arch. Or.* vi, p. 16, fig. 9.

PYRAMID.

Views, LANSING, op. cit. in *N. Y. Metro. Bull.* Pt. ii, Nov. 1933, pp. 5, 11, figs. 1, 2, 10. Foundation deposits, id. ib. Pt. ii, April 1933, pp. 9-14, figs. 6-12.

Chapel at entrance.

Relief with King before offering-table, blocks from cornice, and gargoyles, id. ib. Pt. ii, Nov. 1933, pp. 6-9, figs. 3, 5-8.

Passage to Sepulchral Chamber.

Quarry inscriptions of year 10, id. ib. p. 6, fig. 4.

Small Pyramids.

PYRAMID between Enclosure walls, on south side.

See id. ib. Pt. ii, July 1920, pp. 9-10. Plan and section, GAUTIER and JÉQUIER, op. cit. pp. 43-4, figs. 41-2, cf. pp. 46, 49; id. op. cit. in *Rev. Arch.* 3^e Sér. xxix, p. 56, fig. 19.

PYRAMID at south-east corner of Pyramid.







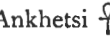
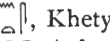

See LANSING, op. cit. pp. 7-9, figs. 5, 6. Plan, id. ib. p. 7, fig. 4.

PYRAMIDS north of Mortuary Temple.

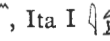
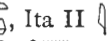
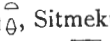
See LYTHGOE, op. cit. in *N. Y. Metro. Bull.* Pt. ii, Feb. 1915, pp. 5-6, with figs. 3, 5.

Late Tomb.

PIT A. Ptolemaic or Roman.

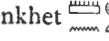
Inscribed offering-tables of various women holding offices in the temple, Senbita , 'Ankhetsi , Khetysonb , Ita I , Ita II , Sitmekut I , Sitmekut II , Menkhet , Heḳsonb , Sit-Ḥathor , Sit'ankhu , Heḳwen , and Nakht , Dyn. XII, rebuilt into tomb-chamber, now in Cairo Mus., GAUTIER and JÉQUIER, op. cit. in *Mém. Inst. Fr. Arch. Or.* vi,

pp. 52-9, figs. 51-63; of Sitmekut II, id. op. cit. in *Rev. Arch.* 3^e Sér. xxix, p. 68, fig. 24; of Nakht, No. 23029, KAMAL, *Tables d'Offrandes* (Cat. Caire), pl. xiii, p. 24; texts of Hekwen, Sitmekut II, Heksonb, Khetysonb, Ita I, 'Ankhetsi, Sitmekut I, and Senbita, Nos. 23049-23056, id. ib. pp. 31-50; texts of Sit-Hathor and Sit'ankhu, Nos. 23062, 23064, id. ib. pp. 53-4, 55.

Mastabas outside Enclosure.

NORTH MASTABA. (LXII of LEPSIUS.)

Plan and sections, GAUTIER and JÉQUIER, op. cit. in *Mém. Inst. Fr. Arch. Or.* vi, pp. 64-7, figs. 76-9.

Granite sarcophagus (uninscribed) and canopic box, in New York, Metropolitan Mus., see *A Handbook of the Egyptian Rooms* (1911), p. 74 [top].

Historical inscription, LANSING, op. cit. in *N. Y. Metro. Bull.* Pt. ii, Nov. 1933, p. 31, fig. 38, cf. p. 25.

Fragment of stela from east face, found in débris, GAUTIER and JÉQUIER, op. cit. p. 63, fig. 75.

Jamb of Rehi $\leftarrow \text{𓏏} \text{𓏏}$, found in pit east of last, id. ib. p. 73, fig. 93.

IMḤŌTER, Chancellor; High priest of Heliopolis; &c.

See LYTHGŌE, op. cit. in *N. Y. Metro. Bull.* Pt. ii, Feb. 1915, pp. 6-20, figs. 8, 9, 15. Plan, id. ib. p. 8, fig. 3.

Pair of wooden statues of Sesostris I as King of Upper and Lower Egypt respectively, and shrine containing Anubis-symbol, found in chamber in enclosure wall, id. ib. pp. 13-21, cover, figs. 8-14, 16, 17, 19; id. op. cit. in *Anc. Eg.* (1915), plate opposite p. 145, and pp. 149-152, figs. 4-8; Upper Egyptian statue, in Cairo Mus., EVERS, *Staat aus dem Stein*, i, pl. 46; BLACKMAN in ROSS, *The Art of Egypt through the Ages*, p. 138 [1]; Lower Egyptian statue, in New York, Metropolitan Mus., *Anc. Eg.* (1915), second plate after p. 192.

Divine and solar barks, found on south side of mastaba, and views showing positions, LYTHGŌE, op. cit. in *N. Y. Metro. Bull.* Pt. ii, Feb. 1915, pp. 11, 13, figs. 4-8; divine bark and view, id. op. cit. in *Anc. Eg.* (1915), pp. 147, 148, figs. 2, 3.

SESENBNEF $\text{𓏏} \text{𓏏} \text{𓏏}$, Chief lector.

Sarcophagus, GAUTIER and JÉQUIER, op. cit. pls. xvi-xxvi, p. 77, figs. 95-6.

Canopic jars; texts, id. ib. p. 75, fig. 94.

NAKHT $\text{𓏏} \text{𓏏}$, Overseer of the Cabinet.

Sarcophagus Chambers.

Plan and section, id. ib. p. 81, fig. 98.

Double sarcophagus; texts, id. ib. pls. xxvii, xxviii, pp. 83-5, figs. 101-5.

Statuette of deceased, in Cairo Mus. 501, id. ib. p. 80, fig. 100; BORCHARDT, *Statuen und Statuetten* (Cat. Caire), ii, pl. 85, p. 72.

Base of statuette of Mentuhotp $\text{𓏏} \text{𓏏} \text{𓏏}$, found in débris of shaft, in Cairo Mus. 502, GAUTIER and JÉQUIER, op. cit. p. 80, fig. 99; text, BORCHARDT, op. cit. ii, p. 72.

SEḤETEPEBRĒ-'ANKH $\text{𓏏} \text{𓏏} \text{𓏏}$, Real royal acquaintance; Steward. Temp. Sesostris III. South of Enclosure wall, near south-west corner.

Statue of deceased, LANSING, *The Museum's Excavations at Lisht* in *N. Y. Metro. Bull.* Pt. ii, Dec. 1924, p. 43, fig. 15.

SENUSERT-'ANKH  ♀, High priest of Ptah in Memphis; Royal stone-cutter and builder. Probably temp. Sesostris I. About two hundred metres east of outer Enclosure wall of Pyramid.

See id. ib. Pt. ii, Nov. 1933, pp. 9-25; position, id. ib. p. 11, fig. 10. Plans and section, id. ib. pp. 13, 17, figs. 13, 19. View, id. ib. p. 21, fig. 24.

Between Enclosure walls of tomb.

Statue of Au, Steward, black granite statuette of Kay , Steward, inscribed statue (no name), and box with mud tablets, id. ib. pp. 24, 25, figs. 28, 29, 31, 32.

Hall.

Black granite lintel, id. ib. p. 12, figs. 11, 12.

Sarcophagus Chamber.

Views of entrance, id. ib. pp. 20, 23, figs. 22, 23, 26, 27, cf. pp. 21, 22, figs. 24, 25.

Jamb and three walls. Pyramid-texts, HAYES in id. ib. pp. 33, 35-7, figs. 40-5, cf. pp. 26-38.

Sarcophagus-lid, LANSING, op. cit. in ib. pp. 18-19, figs. 20-1.

Pit A. (Plunderer's entrance to Sarcophagus Chamber.)

Granite blocks with titles of deceased, id. ib. p. 15, figs. 15, 16, cf. p. 11.

Statue of deceased, and female figures from statue-group (one found in Pit B), id. ib. pp. 14, 16, figs. 14, 17, 18, cf. pp. 11, 12.

Finds.

Granite statue-base of a vizier, found near south-east corner of Enclosure wall; text, GAUTIER and JÉQUIER, op. cit. p. 60, fig. 70, cf. p. 61.

Statuette of Senusert, Official, found in débris south of Pyramid, LANSING, op. cit. p. 34, fig. 1.

Wooden statue of female offering-bringer, model boats, and fragments of models, found in pit outside outer Enclosure wall, id. ib. pp. 40-2, figs. 9, 10, 13, 14.

Miscellaneous.

(From Lisht, but exact provenance unknown.)

Granite architrave of Khephren, re-used in one of the Pyramids; cartouche, MASPERO, *Études de Mythologie et d'Archéologie in Bibliothèque Ég.* i. 148-9; see GAUTHIER, *Le Livre des Rois*, i. 88 [ix].

Stela of Hēpu , King's son, Middle Kingdom, in Cairo Mus.; name, id. ib. ii. 130 [25].

KAFR 'AMMÂR AND TARKHÂN

Map showing position, and plans of site showing cemeteries, PETRIE, WAINWRIGHT, and GARDINER, *Tarkhan I and Memphis V*, pl. lxix; PETRIE, *Tarkhan*, ii, pl. xlvi.

CEMETERIES

(Protodynastic, Dyn. III-XI, Dyn. XXIII-XXV, Ptolemaic and Roman)

AND MASTABA-FIELD

(Dyn. I-II and Dyn. IV or V)

See PETRIE, WAINWRIGHT, and GARDINER, op. cit. pp. 1-31, pls. i-lxxvi; PETRIE, op. cit. passim; PETRIE and MACKAY, *Heliopolis, Kafr Ammar and Shurafa*, pp. 8-38, pls. xii-xxxiv, xxxvii, xxxviii [1-3, 6-13], xxxix [22-4, 32].



MASTABA OF SENIR . Temp. Zet, Dyn. I.

See PETRIE, WAINWRIGHT, and GARDINER, op. cit. pp. 13-19. Plan and section, id. ib. pls. xviii, xix [upper right]. Views, and objects from tomb, id. ib. pls. xv-xvii, xix, xx.

FAMILY-TOMB, High priests of Khnum in the city of Smen-Ḥōr (capital of xxist nome). Dyn. XXV.

See id. ib. pp. 34-5; GRIFFITH in *J.E.A.* iii. 142. Plan, PETRIE and MACKAY, op. cit. pl. xxxiv [bottom right].

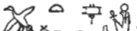
Sarcophagus Chambers.

Coffins of Pefteu'arē' , High priest of Khnum, his son Khnememḥēt , High priest of Khnum, and granddaughter Merneith , id. ib. pls. xxix [1-3], xxxi [3], cf. pp. 34-5; texts of coffin of Merneith, in Brussels, Musées Royaux du Cinquanteaire, E. 5886, SPELEERS, *Rec. des Inscr. Ég.* 88 [335].

Statuettes, &c., PETRIE and MACKAY, op. cit. pls. xxix [4-6], cf. p. 35.



VARIOUS.

Coffin of Wezebt , Royal acquaintance, Old Kingdom; text, id. ib. pl. xiv [lower], cf. pp. 18 [No. 535], 28 [49].

Head-rest and coffin of Shepses , First under the King of the Great House, Dyn. X-XI; texts, id. ib. pls. xv [lower], xviii [10], cf. p. 15 [No. 226].

Coffin of Khety , Chancellor of the King of Lower Egypt, Dyn. X-XI; texts, id. ib. pl. xxvi [bottom].

Inscribed coffin; texts, id. ib. pl. xv [upper], cf. pp. 31, 32 [No. 509].

Offering-tables of Ḥen , and of 'Ankhnūfer , Dyn. XXIII-XXV, id. ib. pls. xxx [1, 2], xxxi [1], cf. p. 35.

TEMPLE. DYN. XXIII-XXV (?)

On face of hills at eastern edge of desert.

Plan, id. ib. pl. xxxv. Views, id. ib. pl. xxxvi, cf. p. 37.

Granite fragment with head of King, New Kingdom, in Copenhagen, Ny Carlsberg Mus., Æ.I.N. 1513, MOGENSEN, *La Collection égyptienne*, pl. cix [A 738], cf. p. 102.

EL-GIRZA AND EL-RIQQA

NECROPOLIS

See ENGELBACH, *Riqqeh and Memphis VI*, with chapters by HILDA PETRIE, MURRAY, and PETRIE, pp. 1-32, pls. i-lii. Map of district showing cemeteries, id. ib. pl. xlvi.

Cemetery A. Sesostris I and II.

See id. ib. pp. 4-9. Plan, id. ib. pl. xvii.

TOMB OF ḤETEP , Lady of the house. (10 of ENGELBACH.)

Coffin; texts, id. ib. pl. xxvi [upper], cf. pp. 5 [13], 28 [71].

TOMB OF ANTEF , Overseer of the Gate. (22 of ENGELBACH.)

Coffin, usurped from Ameny , id. ib. pls. xxiv, xxv, xxvi [lower], cf. pp. 8 [16], 22, 23 [60], 29 [72]. Wooden ka-stature found on top of coffin, in Cairo Mus., id. ib. pl. viii [1], cf. p. 14 [33].

TOMB OF SIWAZET , Regulator of a guild. (166 of ENGELBACH.)

Plan and section, id. ib. pl. xlvi.

Coffin, id. ib. pl. xxiii, cf. pp. 23 [61], 24-5 [62-4], 29.

ROCK-TOMB OF SENMERY , Regulator of a guild. (191 of ENGELBACH.)

Plan and sections, id. ib. pl. xlvi.



Chapel.

Walls, painted scenes of deceased, wife, and family with food-offerings, and female servants with offerings and men bringing animals, id. ib. pl. xxvii [top and right], cf. pp. 23, 25-6.

Fragments of inscription of deceased with name of son, found scattered in cemetery, but originally from here, id. ib. pl. xxvii [lower left], cf. pp. 20 [bottom], 30.

Fragments of a stela, found in other tombs, id. ib. pl. xx [3], cf. pp. 18-19, 28 [top].

FINDS.

Canopic jars of Senusert  and Nebesen , in tomb 116, now in Copenhagen, Ny Carlsberg Mus., Æ.I.N. 1500-1503, id. ib. pl. vii [1-8], cf. pp. 13-14 [32]; MOGENSEN, *La Collection égyptienne*, pl. lxxiii [A 564-7], cf. p. 73.

Canopic jars of Ameny , in tomb 510, now in New York, Metropolitan Mus., ENGELBACH, op. cit. pl. vii [9-12], cf. p. 14.

Jewellery with names of Sesostris II and III, in tomb 124, now in Manchester, University Mus., id. ib. pl. i [1-5], cf. pp. 11-13; id. *The Jewellery of Riqqeh in Anc. Eg.* (1914), frontispiece [1-5], cf. pp. 3-4; part, PETRIE, *The British School of Archaeology in Egypt* in *J.E.A.* i, pl. vi, cf. p. 44.

Limestone ka-statue of Neher , ENGELBACH, op. cit. pl. xii [8, 9], cf. p. 16 [40].

Two jambs, each with relief of a man and a woman, Dyn. IV, re-used in Dyn. XII tomb No. 5, now in Copenhagen, Ny Carlsberg Mus., Æ.I.N. 1518, 1519, id. ib. pl. xv [3, 4], cf. p. 17 [44]; MOGENSEN, op. cit. pl. xciv [A 676, 677], cf. p. 90.

Fragment of relief showing part of plant, in tomb 96, ENGELBACH, op. cit. pl. xxii [9], cf. pp. 19-20 [52].

Fragment of stela of Senusert-sonb, found at mouth of dromos of tomb 306 (but intrusive), id. ib. pl. xxi [5], cf. pp. 9 [21], 19.

Part of stela of Bekamün , id. ib. pl. xxi [2], cf. p. 19.

Fragment of stela found in tomb 27, now in New York, Metropolitan Mus., id. ib. pl. xx [1], cf. pp. 7, 17 [45], 27.

Cemetery B. Dyn. XII, XVIII, XIX, XXII-XXVI, Ptolemaic, Roman.

Stela of Ib , with scenes of catching birds with clap-net and servants grinding corn at sides, Dyn. IX-X, found in Dyn. XXVI shaft, now in Copenhagen, Ny Carlsberg Mus., Æ.I.N. 1515, ENGELBACH, op. cit. pls. v [3], vi, cf. pp. 13 [31], 26-7 [68]; MOGENSEN, *La Collection égyptienne*, pl. xcvi [A 680], cf. pp. 90-1.

Late offering-tables, ENGELBACH, op. cit. pl. xxi [1, 3, 4], cf. p. 19.

Black granite inscribed statuette of woman, Dyn. XII, found in débris, now in Cairo Mus., id. ib. pl. viii [2-4], cf. p. 14.

Cemetery C1. Dyn. XVIII-XIX and Roman.TOMB OF BERI , Scribe. Temp. Tuthmosis III. (296 of ENGELBACH.)

Jewellery, &c., in Edinburgh, Royal Scottish Mus., id. ib. pls. i [6-11], xi [4], cf. pp. 10, 15-16 [38]; id. *The Jewellery of Riqqeh in Anc. Eg.* (1914), frontispiece [6-10], cf. p. 4.

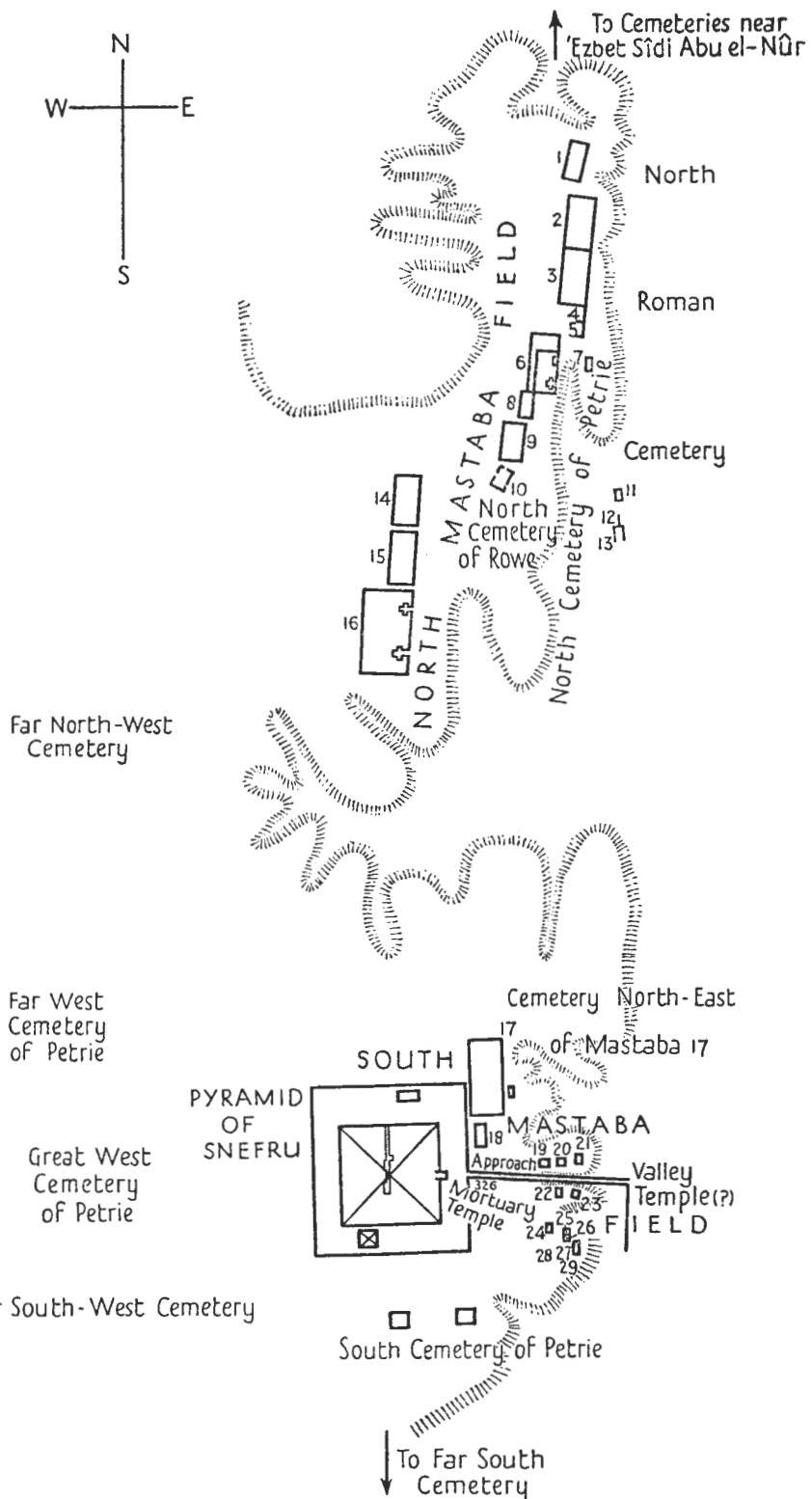

MAIDÛM. KEY-PLAN.

Adapted from PETRIE, *Meaum*, pl. i, with additions from ROWE in *Pennsylvania University Museum Journal*, March 1931, pls. iii, viii, and other plans supplied by him.

Cemetery D. Dyn. XVIII-XIX.

Rough coloured stela, Dyn. XIX, from grave 409, now in Manchester, University Mus., id. *Riqqeh and Memphis VI*, pl. xx [2], cf. pp. 17 [45], 27 [70].

Cemetery E. Dyn. XVIII-XIX, re-used Dyn. XXII-XXVI.



See PETRIE, WAINWRIGHT, and MACKAY, *The Labyrinth, Gerzeh and Mazghuneh*, pp. 26-8 [39], pls. xvi [2-4], xviii-xxii.

FAMILY-TOMB OF IPY , Scribe; Overseer of the fields of the Aten; Mayor of Maidûm. Temp. Amenophis IV. (201, 202 of ENGELBACH.)

In Munich, Glyptothek.

Description and objects, ENGELBACH, op. cit. pp. 10-11, pls. xvi [2, 7, 8], xviii [86-105], xxii [4, 5, 10-12]. Plans, id. ib. pl. xlvi.

Cornice (in Munich), and jamb (in Cairo Mus.), id. ib. pls. xv [1, 2], xix [3], cf. p. 17 [43].

Stelae of Mey , Remeh , and another, Dyn. XVIII, PETRIE, WAINWRIGHT, and MACKAY, op. cit. pls. xx [13, 14], xxii [13].

Cemetery G. Predynastic.

See id. ib. pp. 1-8, 21-4, pls. i-xiii.

MAIDÛM 

Plan of Pyramid-field, L. D. i. 44 [upper]; PETRIE, *Medum*, pls. i, v, vi; ROWE, *The Eckley B. Coxe, Jr., Expedition Excavations at Meydûm, 1929-30 in Pennsylvania Univ. Mus. Journal*, xxii, March 1931, pl. viii; BURTON MSS.* 25620, 140.

Pyramid. Snefru.

See L. D. *Text*, ii, pp. 1-6; PETRIE, MACKAY, and WAINWRIGHT, *Meydum and Memphis III*, pls. i [1-4], xiv [1-3], cf. pp. 1-2, 6-9; PETRIE, *Medum*, pp. 5-8, 10-11; PETRIE, WAINWRIGHT, and MACKAY, *The Labyrinth, Gerzeh and Mazghuneh*, p. 25 [37]; ROWE, op. cit. pp. 1-46; BORCHARDT, *Die Entstehung der Pyramide*, passim. Plan and sections, PETRIE, op. cit. pls. ii, iii; ROWE, op. cit. pls. iii, iv; BORCHARDT, op. cit. pls. 3, 4; section, PETRIE, WAINWRIGHT, and MACKAY, *The Labyrinth* [&c.], pl. xiv. Views, DENON, *Voyage* (1802), pl. 26 [2, 3]; L. D. i. 45; MARIETTE, *Voyage*, pl. 15; BORCHARDT, op. cit. pl. 1; ROWE, op. cit. pls. xvi-xx, xxii-xxiv [1], xxv. Sketch, and sketch-plan of site, WILKINSON MSS.* xii. 159-60 [top]; sketch, BURTON MSS.* 25620, 139.

Quarry-marks, PETRIE, MACKAY, and WAINWRIGHT, *Meydum* [&c.], pls. v, vi [upper], cf. p. 9; ROWE, op. cit. pls. vi, xxxvi [3], xxxviii [2], pp. 20-2.

VALLEY TEMPLE.

See PETRIE, MACKAY, and WAINWRIGHT, op. cit. pp. 2, 8; PETRIE, WAINWRIGHT, and MACKAY, *The Labyrinth* [&c.], p. 24 [36].

Foundation deposit, PETRIE, MACKAY, and WAINWRIGHT, *Meydum* [&c.], pl. xxv [lower].

APPROACH.

See ROWE, op. cit. pp. 34-6. Plan and sections, PETRIE, MACKAY, and WAINWRIGHT, op. cit. pls. ii, iii [upper], cf. pp. 6-8; ROWE, op. cit. pl. xii. Views, id. ib. pls. xxxi-xxxiv.

MORTUARY TEMPLE, on east side of Pyramid.

See PETRIE, *Medum*, pp. 8-10, 34, pl. xxix [upper]; ROWE, op. cit. pp. 28-34. Plan, sections, and elevations, id. ib. pl. xi; plan and section, PETRIE, op. cit. pl. iv. Views, ROWE, op. cit. pls. xxvi-xxx.

Graffiti,¹ Dyn. VI, XII, and XVIII, including years 26 and 41 of Tuthmosis III, and two of year 30 of Amenophis III, PETRIE, op. cit. pls. xxxii-xxxvi, cf. pp. 9, 40-1; one graffito, year 30 of Amenophis III [=xxxvi (xvii)], ROWE, op. cit. pl. xxxv [2].

Graffito, Dyn. XIX, id. ib. pl. xxxv [1].

Fragment of stela (from a private tomb), found near Temple, id. ib. pl. xxxvii [1], cf. p. 34.

PYRAMID.

Interior.

See ROWE, op. cit. pp. 23-8.

Corridor to Sarcophagus Chamber.

On ceiling near entrance, three hieratic graffiti with names of Amenmosi $\begin{smallmatrix} \text{𓆎} \\ \text{𓆏} \\ \text{𓆐} \end{smallmatrix}$ and Sekri $\begin{smallmatrix} \text{𓆑} \\ \text{𓆒} \end{smallmatrix}$, Scribes, early Dyn. XIX (according to ČERNÝ), NEWBERRY, *Extracts from my Note-books in P.S.B.A.* xxvii, plate opposite p. 104, figs. 1-3, cf. pp. 102-3 [61]; ROWE, op. cit. pl. xxxix [1, 2]; see MASPERO, *Études de Mythologie in Bibliothèque Ég.* i. 149 [bottom].

Tombs within Pyramid Enclosure.

Plans, sections, and views, PETRIE, MACKAY, and WAINWRIGHT, *Medum* [&c.], pls. vii-ix, cf. pp. 2-3, 10-13.

*Necropolis*²

NORTH MASTABA-FIELD. DYN. III.

See PETRIE, *Medum*, pp. 20-1; PETRIE, MACKAY, and WAINWRIGHT, op. cit. pp. 6 [13], 28-9. Plan, PETRIE, op. cit. pls. i, v, vi.

Mastabas 1, 2, 3, 10 [=395 of ROWE's North Cemetery], and 14 [=552 of ROWE], were cleared by the Eckley B. Coxe, Jr., Expedition.³

4. HEKNEN $\begin{smallmatrix} \text{𓆎} \\ \text{𓆏} \\ \text{𓆐} \end{smallmatrix}$, Royal acquaintance.

Excavated by ROWE.³

North false door. Panel, in Oxford, Ashmolean Mus., PETRIE, op. cit. pl. xvi [lower right], cf. pp. 20, 38; CAPART, *Les Débuts de l'Art en Égypte*, p. 248, fig. 177.

6. RE'HOTP $\begin{smallmatrix} \text{𓆎} \\ \text{𓆏} \\ \text{𓆐} \end{smallmatrix}$, High priest of Heliopolis; Commander of troops; son of King Snefru; and NEFERT $\begin{smallmatrix} \text{𓆑} \\ \text{𓆒} \end{smallmatrix}$. Dyn. III.

See PETRIE, op. cit. pp. 15-17. Plans, MARIETTE, *Mon. Div.* pl. 16 [D, E, F]; PETRIE, op. cit. pl. vii [top left, middle right]; DANINOS, *La découverte des statues de Meïdoun in Rec. de Trav.* viii. 73. View of façade, JUNKER, *Wissenschaftliche Unternehmungen in Ägypten und Nubien 1930/31 in Mitteil. d. Deutsch. Inst. Kairo*, ii, pl. xxxvi, cf. p. 148.

A. RE'HOTP. (South tomb.)

Some reliefs, in Cairo Mus., see MASPERO, *Guide* (1914), pp. 51-4 [136].

¹ New edition of graffiti in course of preparation by CRUM and ČERNÝ.

² The marginal tomb-numbers below 200 are those of PETRIE, the rest are of ROWE.

³ To be published by ROWE in *Pennsylvania Univ. Mus. Journal*.

Façade.

Lintel, PETRIE, op. cit. pls. ix [upper], x [upper], cf. pp. 23, 37; MARIETTE, op. cit. pl. 18 [b].

Fragments of two stelae in front of tomb, with name of Prince (or Princess) Bunûfer ¹ in Brit. Mus. 1273, 1274, PETRIE, op. cit. pl. xii [right], cf. pp. 24, 37; MARIETTE, *Mastabas*, 485; *Hiero. Texts* [&c.], Pt. i, pl. 28 [lower middle]; see *Guide*, Sculpture (1909), pp. 21-2 [68, 69] (called Giza).

Passage.

South wall. Three registers, hunting before deceased and wife, PETRIE, op. cit. pl. ix [lower], cf. pp. 23, 37; see MARIETTE, op. cit. 480.

North wall. Two registers, remains of fowling and fishing before deceased and wife, PETRIE, op. cit. pl. x [lower], cf. pp. 23, 37; see MARIETTE, op. cit. p. 481 [top].

Hall.

East (entrance) wall. Upper part, deceased watches boat-building and men fishing with net, lower part, three registers, procession of estates, in Cairo Mus. 136a, 136b, PETRIE, op. cit. pl. xi, cf. pp. 23, 37-8; men fishing with net, DEMEL, *Die Reliefs des Kultkammers des Kaninisut* [&c.] in *Jahrbuch d. Kunsthistor. Sammlung in Wien* (1929), p. 22, Abb. 17; names of estates south of door, MARIETTE, *Mastabas*, 481 [middle, columns 4-6, 10-12]; man with antelope north of door, DE MORGAN, *Recherches sur les Origines de l'Égypte*, i, p. 172, fig. 510.

South wall. Three registers, fish-curer, two men bringing fish, man ploughing, and two registers estates, PETRIE, *Medum*, pl. xii [left], cf. pp. 23-4, 38; names of estates, MARIETTE, op. cit. 481 [middle, columns 1-3, 7-9]; two men carrying fish, DE MORGAN, op. cit. i, p. 177, fig. 520; MASPERO, *Hist. Anc. des peuples de l'Orient, Les Origines*, fig. on p. 37.

West wall. Figures of deceased on walls each side of recess, and niche with false door, PETRIE, op. cit. pls. xii [middle], xiii, xiv [left], cf. pp. 24, 38; niche, MARIETTE, *Mon. Div.* pls. 18 [a], 19 [a, b]; upper part of false door, in Brit. Mus. 1242, BUDGE, *Egyptian Sculptures in the British Museum*, pl. v; *Hiero. Texts* [&c.], Pt. i, pl. 20; *Guide*, Sculpture (1909), fig. on p. 13; *Guide to the Egyptian Collections* (1930), p. 296, fig. 159; deceased on south side, in Louvre E. 11430, see BOREUX, *Guide-Catalogue Sommaire*, i (1932), p. 231.

North wall. Three registers, men bringing oryx, addax, and ibex, and two registers servants with meat, &c., PETRIE, op. cit. pl. xiv [middle], cf. pp. 24, 38; men with addax and ibex, DE MORGAN, op. cit. i, p. 172, figs. 510-12.

Statues of deceased and wife, in Cairo Mus. 3, 4, MARIETTE, *Mon. Div.* pl. 20; id. *Mastabas*, 487; id. *Voyage*, pl. 16; BISSING, *Denkmäler*, 5A; CAPART, *L'Art Égyptien* (1909), pl. 18; BORCHARDT, *Statuen und Statuetten* (Cat. Caire), i, pl. i, pp. 3-5; PERROT and CHIPIEZ, *Hist. de l'Art*, i, pl. ix opposite p. 638; RHONÉ, *Auguste Mariette, esquisse de sa vie* [&c.] in *Gazette des Beaux-Arts* (1881), plate opposite p. 250; BOREUX, *L'Art Égyptien*, pl. xxvi; CAPART and WERBROUCK, *Memphis*, p. 351, fig. 338; HALL in ROSS, *The Art of Egypt through the Ages*, 103; STEINDORFF, *Die Kunst der Ägypter*, 177-8; many recent copies; statue of wife, and head of deceased, MASPERO, *Guide* (1914), p. 71, figs. 19, 20; statue of wife, id. *Hist. Anc. des peuples de l'Orient, Les Origines*, fig. on p. 363; heads of both, id. ib. fig. on p. 347, and pl. 2 opposite p. 363; head of deceased, PERROT and CHIPIEZ, op. cit. p. 639; *Anc. Eg.* (1916), second plate after p. 48; of wife, PETRIE, *Arts and Crafts*, fig. 24 opposite p. 33. Description of finding of statues, DANINOS, *La découverte des statues de Meïdoum* in *Rec. de Trav.* viii. 69-73.

¹ These are the blocks of Bunûfer mentioned in *Bibl.* iii, p. 67, incorrectly stated as coming from Giza. Bunûfer may be the princess whose tomb was discovered at Giza by Selim Hassan in 1932.

B. NEFERT. (North tomb.)

Hall.

West wall, in fragments, distributed among various museums, see PETRIE, MACKAY, and WAINWRIGHT, *Meydum and Memphis III*, p. 5. False door with family (middle in Oxford, Ashmolean Mus., left side in Cambridge, Fitzwilliam Mus., right side in Munich), and estates on either side (in Brussels and Copenhagen), PETRIE, *Medum*, pl. xv, cf. pp. 24-5, 38; names and titles from lintel, MARIETTE, *Mastabas*, 483; names of estates, id. ib. 484; four figures of estates from north side, in Copenhagen, Ny Carlsberg Mus., Æ.I.N. 1132, MOGENSEN, *La Collection égyptienne*, pl. xci [A 655], cf. p. 87; three of them, PETRIE, MACKAY, and WAINWRIGHT, op. cit. pl. xx [4-6], cf. p. 5; names of the seven estates on south side, in Brussels, Musées Royaux du Cinquantenaire, E. 4950, SPELEERS, *Rec. des Inscr. Ég.* 4 [36].

Sarcophagus Chamber.

Impression of wooden coffin in the débris,¹ JUNKER, op. cit. in *Mitteil. d. Deutsch. Inst. Kairo*, ii, pl. xxxvii, cf. p. 148.

7. NAME UNKNOWN, . . . of the lake of the crocodile; Commander of troops; &c.

Façade.

South false door. Part of lintel, PETRIE, *Medum*, pl. xvi [bottom], cf. pp. 20, 38-9.

Sarcophagus Chamber.¹8. NEḤEP ⸎⸏ ⸎⸏, ¹ King's son.

Id. ib. pl. v, cf. pp. 18-19; name, JUNKER, op. cit. in *Mitteil. d. Deutsch. Inst. Kairo*, ii, p. 149; see *Chronique d'Égypte*, Jan. 1932, 76-7.

9. RĒ'NŪFER (?).²

See PETRIE, op. cit. pp. 17-18 [28]; MARIETTE, *Mastabas*, 477 [H. 3°]. Plan and section, PETRIE, op. cit. pl. vii [middle].

Hall.

Niche. Remains of procession of estates, id. ib. pl. xiv [right], cf. pp. 24, 38.

North Chamber, cleared by ROWE.

Two fragments¹ with titles 'King's son' and 'Chief of the Ten of Upper Egypt', found in east side of mastaba.

16. NEFERMA'ET ⸎⸏ ⸎⸏, Prophet of goddess Bubastis, and Shesmetet; Priest of Min; &c.; son of King Snefru; with wife ITET ⸎⸏.

See PETRIE, op. cit. pp. 14-15; PETRIE, MACKAY, and WAINWRIGHT, *Meydum* [&c.], pp. 4-5, 18-22, pl. i [5]; PETRIE, WAINWRIGHT, and MACKAY, *The Labyrinth* [&c.], pp. 25-6 [38], pl. xvii. Plans, MARIETTE, *Mon. Div.* pl. 16 [A, B, C]; plan and sections of Neferma'et, PETRIE, MACKAY, and WAINWRIGHT, *Meydum* [&c.], pls. iii, iv; plan of Neferma'et, PETRIE, *Medum*, pl. vii [top right]; plan and sections of Itet, PETRIE, WAINWRIGHT, and MACKAY, *The Labyrinth* [&c.], pl. xv.

¹ To be published later by ROWE in *Pennsylvania Univ. Mus. Journal*.

² Perhaps the same as tomb of Khent, see LOFTIE, *A Ride in Egypt* (1879), p. 210; MURRAY, *A Handbook for Travellers* (1891), p. 397; BAEDEKER, *Ober-Aegypten* (1892), p. 4.

A. NEFERMA'ET, in Cairo Mus. 43809. (South tomb.)

View showing Façade and Hall, VILLIERS STUART, *Nile Gleanings*, pl. F opposite p. 33.

Façade.

Lintel and jambs with deceased, wife, and family, PETRIE, *Medum*, pls. xvi [upper], xvii [right], xviii [left], cf. pp. 25, 39.

South of doorway, hunting scenes, id. ib. pl. xvii [left], cf. p. 25; man with leopard, and dog hunting jackals at bottom, WRZINSKI, *Atlas*, i. 396 [B]; DE MORGAN, *Recherches sur les Origines de l'Égypte*, i, p. 174, fig. 515; FARINA, *La Pittura Egiziana*, x.

North side of doorway, hunting, cooking, fishing with net, fowling with draw-net, and ploughing, PETRIE, *Medum*, pl. xviii [right], cf. p. 25; fowling and ploughing, WRZINSKI, *Atlas*, i. 396 [A]; FARINA, op. cit. ix.

Hall.

South wall, deceased and wife with estates below, north wall, deceased in palanquin, and estates below, PETRIE, op. cit. pls. xix, xxi, cf. pp. 26, 39; texts of upper registers of procession of estates, MARIETTE, *Mastabas*, 474 [middle].

Rear wall. False door, PETRIE, op. cit. pl. xx, cf. pp. 26, 39; upper part, in Louvre, see BOREUX, *Guide-Catalogue Sommaire*, i (1932), pp. 231-2; names from lower part, MARIETTE, op. cit. 474 [bottom].

Find.

Fragment of painted hieroglyphs from façade, in Philadelphia, Pennsylvania Univ. Mus., PETRIE, op. cit. pl. xxviii [1], cf. p. 27.

Fragment of stela found in front of chamber, id. ib. pl. xvi [middle left], cf. p. 25.

Stamped brick of Neferma'et, in Manchester Mus., PETRIE, MACKAY, and WAINWRIGHT, *Meydum and Memphis III*, pl. xx [2].

Wooden door at end of passage, PETRIE, WAINWRIGHT, and MACKAY, *The Labyrinth* [&c.], pl. xvi [1], cf. p. 25.

B. ITET. (North tomb.)

Distributed among various museums, see PETRIE, MACKAY, and WAINWRIGHT, *Meydum* [&c.], p. 5.

Façade.

Lintel, Neferma'et fowling with net (in Oxford, Ashmolean Mus.) and sons bringing birds to deceased (in New York, Metropolitan Mus.), wall south of doorway, butchers (in Brussels), titles (in Brit. Mus.), men bringing animals and boat-building (in Munich), south jamb, Neferma'et (in Bristol) and family (in Edinburgh), north jamb, Neferma'et with Itet and family (in Chicago), north wall, ibex sacrificed (in Cambridge), and six registers, offering-bringers (in Copenhagen), men with cranes, ox, and ibex, two men in canoe (all in Manchester), fowling with net and boy with apes and ibis (both in Copenhagen), MARIETTE, *Mon. Div.* pl. 17 [top, left, and right] (omitting fowling and boy with apes at bottom of north side); PETRIE, *Medum*, pls. xxii-xxiv, cf. pp. 26, 39; upper part, VILLIERS STUART, *Nile Gleanings*, pl. G opposite p. 30; texts of deceased on jambs, SETHE, *Urk.* i. 7 (2); fragment with titles from top of south wall, in Brit. Mus. 1510, *Hiero. Texts* [&c.], Pt. vi, pl. 18 [top left]; offering-bringers, fowling with net, and boy with apes and ibis, in Copenhagen, Ny Carlsberg Mus., Æ.I.N. 1133, MOGENSEN, *La Collection égyptienne*, pl. xci [A 656], cf. pp. 87-8.

Passage.

Fresco of the geese, in Cairo Mus., GRÉBAUT, *Le Musée Égyptien*, i, pl. xxix [lower];

CAPART and WERBROUCK, *Memphis*, p. 33, fig. 31; SCHÄFER, *Von ägyptischer Kunst* (1922) and (1930), pl. 10 [2]; FARINA, *La Pittura Egiziana*, viii; three geese on right, BORCHARDT and REISNER, *Works of Art*, 32 [upper]; MASPERO and ROEDER, *Führer* (1912), pl. 10 [a]; RHONÉ, *Auguste Mariette, esquisse de sa vie* [&c.] in *Gazette des Beaux-Arts* (1881), p. 239; many recent copies.

Fragments of other frescoes, PETRIE, *Medum*, pl. xxviii [2-4], cf. pp. 27-8.

Hall.

South wall. Neferma'et watching boat-building, in Boston Mus., id. ib. pl. xxv, cf. pp. 26-7.

West wall. False door, Neferma'et and family (much destroyed), in Liverpool Mus., id. ib. pl. xxvi, cf. p. 27; MARIETTE, *Mon. Div.* pl. 17 [middle].

North wall. Neferma'et with sister hunting, in Philadelphia, Pennsylvania Univ. Mus., and men bringing animals below, in Brussels Mus., PETRIE, op. cit. pl. xxvii, cf. p. 27.

SOUTH MASTABA-FIELD. DYN. III.

17. NAME UNKNOWN.

See PETRIE, MACKAY, and WAINWRIGHT, op. cit. pp. 3-4, 13-18, pls. x, xi. Plan and section, id. ib. pls. xii, xiii; plan, and view showing architects' notes on corners, PETRIE, *Medum*, pls. vi, viii, cf. pp. 11-14, 37.

Red granite sarcophagus, PETRIE, MACKAY, and WAINWRIGHT, op. cit. pl. x [bottom left]; PETRIE, *The Earliest Stone Tombs in Man* (1910), pl. 1-J [middle right], cf. p. 129 [79].

18. NAME UNKNOWN. (256 of ROWE.)

Late pit in north-east corner.¹

22. NEFER . . . U , Lector.

Plan, id. *Medum*, pl. vii [bottom right].

Passage.

West wall. Pairs of oxen led to deceased; omitting deceased, id. ib. pl. xxviii [5], cf. p. 28.

East wall. Remains of harvest before deceased and sons, id. ib. pl. xxviii [6], cf. p. 28.

South wall. Remains of fowling and fishing with net, id. ib. pl. xxviii [7], cf. p. 28.

OTHER CEMETERIES²

North Cemetery of Petrie. Dyn. III.







See PETRIE, MACKAY, and WAINWRIGHT, *Meydum and Memphis III*, pp. 6 [13], 28-35. Plans, id. ib. pl. xxii.

Libation-table of Sezefau , Overseer of the New Towns, Prince of the Residence of Khufu in Sebat, found in front of recess of a mastaba, now in Cambridge, Fitzwilliam Mus., id. ib. pl. xxxi [top left], cf. pp. 6 [13], 28 [51].

¹ To be published later by ROWE in *Pennsylvania Univ. Mus. Journal*.

² North Roman Cemetery, North Cemetery of ROWE, Dyn. III-IV and later, Tombs near and built into mastabas 1-16 of PETRIE, Dyn. IV, XVIII, XXII, Late Period and Ptolemaic, Cemetery North-East of mastaba 17, Dyn. III, IV, and Late Period, and Tomb 326, Dyn. IV, are to be published later by ROWE in *Pennsylvania Univ. Mus. Journal*.

Tombs Built into Mastaba 17 of Petrie.¹ Dyn. XVIII–Roman.





Coffins of 'Aḥ-tefnakht  (227 of ROWE), Gemshi  (261 A), Amenheru  (265), Saite, . . . bu-pemu (?)  (362), Saite, Sit-Mut  (384), Dyn. XXII, scarab of Si-i'oh  (211), Dyn. XVIII (?), and ushabti of Ḥori  (218), Dyn. XIX or later.

South Cemetery of Petrie.





Mastabas, see PETRIE, MACKAY, and WAINWRIGHT, op. cit. p. 35.

Far South Cemetery.¹ Dyn. XXX to Graeco-Roman.

See id. ib. pp. 6, 36, pl. xxxi [middle left].

Coffins¹ of Pedubaste  (525), Dyn. XXX, of Ta(?)-ēsi  Zeho , and Ḥepmen  (527), Dyn. XXX.

Far South-west Cemetery.¹ Dyn. IV and later.

Coffins¹ of a son of 'Ankhes(en)mut  of 'Ankhef  and Pkef (?)  (251), Dyn. XXII–XXVI, of Sit-Ḥaremḥêt  and Khent-khety-em-ḥêt  (314), Dyn. XII.

Great West Cemetery of Petrie.¹ Dyn. III, two of the tombs re-used in Dyn. XXII.

Description, PETRIE, MACKAY, and WAINWRIGHT, op. cit. pp. 5 [11], 22–4, pl. xiv [5–6].

Plan of site, id. ib. pl. xvi [upper]; plans and sections, id. ib. pl. xv; PETRIE, *Medum*, pl. vii [bottom left].

Far West Cemetery of Petrie. Dyn. III, re-used Dyn. XXII.





See PETRIE, MACKAY, and WAINWRIGHT, op. cit. pp. 6 [12], 24–8, pl. xiv [4].

Plan of site, plans, and sections, id. ib. pls. xvi [lower]–xviii.

Far North-west Cemetery.¹ Dyn. IV, re-used later.

See ROWE, op. cit. pls. 3, 4 [3, 4, 7], 45 [1, 4].

Cemeteries near 'Ezbet Sîdi Abû el-Nûr.¹ Ptolemaic and Graeco-Roman.

Coffins of Pedusiri  and Esenkhebi  (A.N. 15), Ptolemaic, of Pedusiri  and wooden statuette of Sen'ankh  (A.N.S. 44), Graeco-Roman, coffin with prayers in hieroglyphs and name of owner Hatres Pasos in Greek (A.N.S. 46), and wooden statuettes bearing name Ḥor  (A.N.S. 30), Graeco-Roman.¹

Miscellaneous.

(From Maidûm, but exact provenance unknown.)

Sculptor's trial-piece,¹ Dyn. IV, showing figure of a King, apparently Snefru, found in quarry near north face of Pyramid.

Statue of Ḥenka , Chief of Ten of Upper Egypt, Overseer of the Pyramids of Snefru, Dyn. V, in Berlin Mus. 7334, *Aeg. und Vorderasiat. Alterthümer*, pl. 5 [right]; *Ausführ. Verzeichnis* (1899), p. 68, Abb. 10; text on base, *Aeg. Inschr. Mus. Berlin*, i. 70.

Two fragments of painted wall with name of son of deceased, 'Ankhirptah , Old Kingdom, in Berlin Mus. 7336, 7337; texts, id. ib. 25; see *Ausführ. Verzeichnis* (1899), p. 58.

¹ To be published later by ROWE in *Pennsylvania Univ. Mus. Journal*.

Statuette of Henka , Overseer of every work, Old Kingdom, probably from here, in Vienna Mus.; texts, BERGMANN, *Inchriftliche Denkmäler der Sammlung Aeg. Alterthümer des österr. Kaiserhauses* in *Rec. de Trav.* vii. 179 [2].

Limestone hollow naos with niche containing figure of Osiris dedicated by Psinesu , Scribe of the offerings of all the gods, temp. Amenemhêt III, in Brit. Mus. 1135; front, BUDGE, *Egyptian Sculptures in the British Museum*, pl. xiii; *Guide to the Egyptian Collections* (1909), fig. on p. 219; back, *Guide, Sculpture* (1909), fig. on p. 52.

VI. EL-FAIYÛM

Plan, PETRIE, *Illahun, Kahun, and Gurob*, pl. xxx; SALMON, *Répertoire géographique* in *Bull. Inst. Fr. Arch. Or.* i, plate opposite p. 72; WILKINSON MSS.* xlv. c. a, xlvi. L. 18. Description, id. ib. xxxvii. 5-51, 55-65.¹

KÔM EL-ASL (BACCHIAS)

(Kôm-el-Qaṭl or Umm el-Qaṭl of HOGARTH and GRENFELL.)

TEMPLE OF SOKANOBKONEUS.

See HOGARTH and GRENFELL, *Cities of the Faiyûm in Archaeological Report* (1895-6), pp. 17-18; GRENFELL, HUNT and HOGARTH, *Fayum Towns and their Papyri*, pp. 36-8. Plan, id. ib. pl. iii.

KÔM AUSHÎM (KARANIS)

TEMPLE OF PETESUCHOS-PNEPHERÔS. Roman and Greek Period.

See HOGARTH and GRENFELL, op. cit. pp. 14-19 with two figs.; GRENFELL, HUNT and HOGARTH, op. cit. pp. 30-2. Plan, id. ib. pl. ii. Views, MILNE, *A History of Egypt* (1898), pp. 35, 37, 43, figs. 25, 27, 31.



Lintel of Nero, see *Chronique d'Égypte*, July 1930, 237.

TOWN. Late Ptolemaic and Roman.

Excavated by Michigan University, see their publications.

Plan, WILKINSON MSS.* xxxvii. 10.

FINDS.

Fragment of double-statue of ... ku , Overseer of builders, and Nana , Middle Kingdom to New Kingdom, in Cairo Mus. 859, BORCHARDT, *Statuen und Statuetten* (Cat. Caire), iii, pl. 154, p. 124.

DIMAI (SOKNOPAIΟΥ NĒSOS)

Plan of site and view of temple, L. D. i. 52, 54, cf. *Text*, ii, pp. 35-41; plan, WILKINSON MSS.* xlv. C. c.

TEMPLE OF SOKNOPAIOS. Ptolemaic.

Views of approach and inner shrine, GARDNER, *Two Rarely-Visited Egyptian Temples* in *Discovery*, August 1928, pp. 258, 260.

FINDS.

Bas-relief, Sobk-crocodiles with names, Dyn. XVIII, in Cairo Mus.; texts, DARESSY, *Notes et remarques* in *Rec. de Trav.* xxii. 138 [clxvii].

¹ For accounts of cemeteries and town-sites in the Faiyûm, see GRENFELL, HUNT and HOGARTH, *Fayum Towns and their Papyri*, pp. 1-64.

Statue of Sebkhōtp , Hereditary prince of the (Faiyûm) basin, as scribe, about Dyn. XVIII, probably from here, in Berlin Mus. 11635; texts, *Aeg. Inschr. Mus. Berlin*, ii. 45-6, cf. *Ausführ. Verzeichnis* (1899), p. 139; titles, BRUGSCH, *Der Mōris-See* in *Ä.Z.* xxxi. 23.

Stela dedicated to Esenkhēbi with Greek inscription of year 13 of Ptolemy XIII Neos Dionysos, in Copenhagen, Ny Carlsberg Mus., Æ.I.N. 826, MOGENSEN, *La Collection égyptienne*, pl. cxvi [A 766], cf. p. 107; SCHMIDT, *Choix de monuments égyptiens* (1910), pl. xxxvii [95].

Fragment of statue of priest of Sobk; text, KAMAL, *Quelques jours de fouilles à Dimeh es-Sebaâ* in *Ann. Serv.* xvi. 186 [10].

Upper part of statue of King, Roman, in Cairo Mus. 702, BORCHARDT, *op. cit.* iii, pl. 130, cf. p. 44.

Torso of a priest, Roman, in Hildesheim Mus. 2646, ROEDER, *Die künstlerische Einwirkung der Griechen auf die Ägypter* in *Alt-Hildesheim*, April 1928, p. 57, Abb. 3; see IPPEL and ROEDER, *Denkmäler . . . Hildesheim*, p. 83.

Head of a priest, Graeco-Egyptian, in Hildesheim Mus. 1076, *id. ib.* p. 82, Abb. 27.

Statuette, with demotic inscriptions and figure of camel, Graeco-Roman, in Cairo Mus., BISSING, *Denkmäler, Text* to 108 b [lower].

Statues of priests, Graeco-Roman, in Berlin Mus. 11632, 11633; one, *id. Denkmäler*, 108 a; see *Ausführ. Verzeichnis* (1899), p. 333.

Head of a priest, Graeco-Roman, in Munich, Glyptothek, BISSING, *Denkmäler*, 109-10.

Fragments of statues, Graeco-Roman (some re-used), and sculptured wood, in Berlin Mus. 605, 14052, see *L. D. Text*, ii, pp. 37, 38-9, 40.

TEMPLE OF QAŞR EL-SÂGHA. Old Kingdom (?). Discovered by SCHWEINFURTH in 1884.

Plan, BROWN, *The Fayûm and Lake Moeris*, pl. xvi. Views, *id. ib.* pls. xiv, xv, cf. pp. 51-4; SCHWEINFURTH, *Ein altes Heiligtum* [&c.] in *Illus. Deutsche Monatshefte* (1895), 361, 365; GARDNER, *op. cit.* 259; BITTEL, forthcoming article in *Mitteil. d. Deutsch. Inst. Kairo*.

MEDÎNET QÛTA

(El-Yaûta of DARESSY.)

TOWN. Ptolemaic and Roman.

Black granite boundary stone of She-Sobk, Ptolemaic; text, DARESSY, *Rapport sur El-Yaouta (Fayoum)* in *Ann. Serv.* i. 46.

QAŞR QÂRÛN

TEMPLE. Late Ptolemaic.

Plans, elevation, sections, views, and details, *Descr. de l'Égypte, Ant.* iv, pls. 69, 70 [1-7, 9-18]; plan, section, plan of upper story, and view, *L. D.* i. 51 [lower], 53 [lower]; plans of ground floor and upper story, POCOCKE, *A Description of the East*, i, pl. xxiii [H, I, K, L] opposite p. 61 (called Labyrinth); views and plan, WILKINSON MSS.* xxxvii. 28, 29, 31 [top]; views, RIFAUD, *Voyage*, 144, 145; MASPERO, *Hist. Anc. des Peuples de l'Orient, Les Origines*, fig. on p. 515; GRENFELL, HUNT and HOGARTH, *Fayum Towns and their Papyri*, pl. x [a], cf. p. 63; HOSKINS MSS.* i. 111. Description, *L. D. Text*, ii, p. 42.

Sculpture of ram-headed Amûn, on rear wall of upper story, *Descr. de l'Égypte, Ant.* iv, pl. 70 [8].

BAṬN IHRÎT (THEADELPHIA)

TEMPLE OF PNEPHERÛS. Ptolemy III Euergetes I.

Pylons and altar reconstructed in Court of Alexandria Mus., BRECCIA, *Alexandrea ad Aegyptum* (1922), p. 285, fig. 198, cf. pp. 153-4, 284-5.

Carrying-chair, found in vestibule, now in Alexandria Mus., id. ib. p. 153, fig. 6.

FINDS.

Left wing of wooden door of naos, Ptolemaic or Greek Period, in Cairo Mus. 70024, ROEDER, *Naos* (Cat. Caire), pl. 34, cf. pp. 102-4.

BIYAHMU

COLOSSI OF AMENEMHÛT III.

Plan, elevation, and view of bases, L. D. i. 51 [upper], 53 [upper], cf. *Text*, ii, pp. 34-5; WILKINSON MSS.* xxxvii. 3 [top]; plan, section, and view, PERRING, *The Pyramids of Gizeh*, Pt. iii, pl. xviii, figs. 6, 7; plan and restoration of colossus, PETRIE, *Hawara, Biahmu, and Arsinoe*, pl. xxvi; view, MASPERO, op. cit. fig. on p. 513.

Fragments, PETRIE, op. cit. pl. xxvii [1-9] (Nos. 2 and 3 in Oxford, Ashmolean Museum), cf. pp. 3, 53-6.

MEDÎNET EL-FAIYÛM (CROCODILOPOLIS-ARSINOË)

Plan and sections, RIFAUD, op. cit. 140.

TEMPLE OF SOBK. Dyn. XII, Ramesside, Dyn. XXVI, and Ptolemaic.

See PETRIE, op. cit. pp. 56-9. Plan, id. ib. pl. xxix.

Red granite fragments, AmenemhÛt III, re-used in Pylon, id. ib. pl. xxvii [10, 11], cf. p. 57.

Block of AmenemhÛt III from a wall, in Berlin Mus. 16953, SCHÄFER, *Zierinschrift aus einem Tempel des XIX Jahrhunderts v. Chr. in Amiliche Berichte*, xxxiii, No. 2, Nov. 1911, p. 42, Abb. 22; SCHÄFER and ANDRAE, *Die Kunst des alten Orients*, 286; SCHÄFER, *Von ägyptischer Kunst* (1922), pl. 21; text, *Aeg. Inschr. Mus. Berlin*, i. 212.

Blocks of AmenemhÛt III, in Berlin Mus. 11584-6, 11588; texts, id. ib. 139; see *Ausführ. Verzeichnis* (1899), p. 78.

Block with mutilated name of AmenemhÛt III, in Copenhagen, Ny Carlsberg Mus., Æ.I.N. 822, MOGENSEN, *La Collection égyptienne*, pl. c [A 694], cf. p. 94; SCHMIDT, *Choix de monuments égyptiens* (1910), pl. vii, fig. 14.

Fragments, RIFAUD, *Voyage*, 118 [5, 6, 8]. For positions, see WILCKEN, *Zusätze zu dem Aufsatz: Zur Topographie der Ruinenstätte des alten Schet (Krokodilopolis-Arsinoë)* in *Zeitschr. d. Gesell. f. Allgemeine Erdkunde* (1887), xxii, pp. 87-8 with plan, pl. ii; SCHWEINFURTH, *Ruinenstätte des Alten Schet (Krokodilopolis-Arsinoë)* in ib. 76.

Re-used block from early tomb, PETRIE, op. cit. pl. xxvii [13], cf. p. 57.

Red granite column; text with prenomen of AmenemhÛt I, GOLÉNISCHEFF, *Lettre à M. G. Maspero, sur trois petites trouvailles égyptologiques* in *Rec. de Trav.* xi. 98; BRUGSCH, *Der Möris-See* in *A.Z.* xxxi. 26; see GAUTHIER, *Le Livre des Rois*, i. 259 [xxi], 334 [lxxxii], with note 2.

Finds.

Kîman Fâris.



Granite statue of Sebknakht-renfsonb , Dyn. XIII, in Cairo Mus., EVERS, *Staat aus dem Stein*, i, pl. 142.

Grey granite fragment, year 35 of Ramesses II, in Cairo Mus.; text, GAUTHIER, op. cit. iii. 44 [xxx].

Block with text of Kha'emtar , Lieutenant of chariotry, Ramesside; name and titles, WEIGALL, *Miscellaneous notes in Ann. Serv.* xi. 172 [6].

Mît Fâris.

Upper part of granite statue of Amenemhêt III (?) as priest in Cairo Mus. 395, DE ROUGÉ, *Album Photo.* 119; MARIETTE, *Mon. Div.* pl. 39 [a]; BORCHARDT, *Statuen und Statuetten* (Cat. Caire), ii, pl. 64, cf. p. 13; BISSING, *Denkmäler*, 30; WEIGALL, *Anc. Eg. Works of Art*, 101 [lower]; EVERS, op. cit. i, pls. 127, 128; CAPART, *Les Monuments dits Hyksos*, p. 13, fig. 3 (reprinted from *Ann. Soc. Roy. d'Arch. Bruxelles*, xxvii, 1913); *Anc. Eg.* (1916), first plate after p. 192 [lower]; ENGELBACH, *The so-called Hyksos Monuments in Ann. Serv.* xxviii, pl. i [4], cf. p. 13.

Headless triple-group, of Penptah , Deësisonb , and Harkhebi , Ptolemaic, in Cairo Mus. 882; texts, BORCHARDT, op. cit. iii, pp. 133-4; text with genealogy on back, MARIETTE, *Mon. Div.* pl. 39 [b].

Various.

Cylinder seal, Protodynastic, in Swainson Cowper Collection, SAYCE, *Some Early Egyptian Seal-cylinders in P.S.B.A.* xxii, plate opposite p. 278 [lower 3], cf. p. 280.

Headless statue of Sesostris I, in New York, Metropolitan Mus., EVERS, *Staat aus dem Stein*, i, pls. 42, 43; LYTHGOE, *A Gift to the Egyptian Collection in N.Y. Metro. Bull.* Jan. 1926, p. 4, figs. 1, 2.

Fragment of double-statue of Amenemhêt I and Queen (?), found in street in Medinet el-Faiyûm, L. D. ii. 118 e, f, cf. *Text*, ii, p. 30.

Upper part of Nile-god, temp. Sesostris II (?), in Berlin Mus. 9337, EVERS, op. cit. i, pl. 70; see *Ausführ. Verzeichnis* (1899), p. 81.

Piece of granite column, used as threshold in Medinet el-Faiyûm, L. D. ii. 118 g, cf. *Text*, ii, p. 30; text, WILKINSON MSS.* v. 37 [bottom right], xxxvii. 51.

Fragment of black granite double-statue of Tuthmosis IV and his mother Queen Ti'a ; titles of Queen, BRUGSCH, op. cit. in *Ä.Z.* xxxi. 29 [top]; see GAUTHIER, op. cit. ii, pp. 287 [liii, 1], with note 3, 301 [2], with note 1.

ABGÎG OR BEGÎG

OBELISK OF SESOSTRIS I.

View showing obelisk on ground, *Descr. de l'Égypte, Ant.* iv, pl. 71 [1], cf. *Texte*, iv. 517-20. See plan, POCOCKE, *A Description of the East*, i, pl. xxii [bottom left] opposite p. 57, cf. pp. 59-60.

Broad and narrow faces, BURTON, *Excerpta Hiero.* xxix [left, right]; RIFAUD, *Voyage*, 108 [right]; L. D. ii. 119, cf. *Text*, ii, p. 31; WILKINSON MSS.* xvii. k. 5 [b, c]; HAY*, 29812, 108-11; remains of text below scenes, NESTOR L'HÔTE MSS.* 20396, 342; five registers scenes of King with divinities on broad face, *Descr. de l'Égypte, Ant.* iv, pl. 71 [2-7]; top register, Thoth and goddess from third register, and King before Min and goddess from fifth register, NESTOR L'HÔTE MSS.* 20396, 342 verso; narrow faces, ROSELLINI, *Mon. Stor.* xxv [2 a, b]; narrow faces (in 1827), HALL, *Letters . . . from . . . Wilkinson in J.E.A.* ii, p. 147, pl. xviii opposite p. 148; BURTON MSS.* 25634, 34-6; NESTOR L'HÔTE MSS.* 20396, 343; see CHABÂN, *Rapport sur une mission à l'obélisque d'Abguig (Fayoum)* in *Ann. Serv.* xxvi. 105-8.

(Hauwâret el-Maqtâ')

Plan of site, L. D. i. 46, 47 [middle], and *Text*, ii, p. 11; PETRIE, *Hawara, Biahmu and Arsinoe*, pl. xxv; WILKINSON MSS.* xl. C. b, cf. xxxvii. 49 [bottom].

Pyramid. Amenemhêt III.

(LXVII of LEPSIUS.)

See L. D. *Text*, ii, pp. 24-8; PETRIE, *Kahun, Gurob, and Hawara*, pp. 5-8, 12-17; description, BURTON MSS.* 25618, 22. Sections and view, L. D. i. 47 [lower left], 48; PERRING, *The Pyramids of Gizeh*, Pt. iii, pl. xviii, fig. 5; plan and sections, PETRIE, op. cit. pls. ii-iv; plan, PETRIE, WAINWRIGHT, and MACKAY, *The Labyrinth, Gerzeh and Mazghuneh*, pl. xli [lower right]; view, RIFAUD, *Voyage*, 76 [lower] (called 85). Marks on bricks, id. ib. 88-91 (second plate); see PETRIE, op. cit. pl. iv.

MORTUARY TEMPLE, on north side of Pyramid.

Fragments, Amenemhêt III, in Cairo Mus., PETRIE, *Hawara, Biahmu, and Arsinoe*, pl. vi [5 a].

Fragment of colonnette, id. ib. pl. xxvii [12], cf. p. 6.

PYRAMID.

Entrance on north side.

Fragments, including one with name of Queen Sebekneferurê', in Berlin Mus. 1164, 1166, 1168-74, L. D. ii. 140 k, and *Text*, ii, pp. 24 a-δ, 25 a-ε; *Aeg. Inschr. Mus. Berlin*, i. 153; see *Ausführ. Verzeichnis* (1899), p. 86.

'Well-chamber' (preceding Sarcophagus Chamber).

Alabaster-table of Princess Neferu-Ptah $\begin{matrix} \dagger & \dagger & \square & \text{♀} \\ \text{♀} & \text{♀} & \text{♀} & \end{matrix}$, daughter of Amenemhêt III, in Cairo Mus. 23013, KAMAL, *Tables d'Offrandes* (Cat. Caire), pl. vii, pp. 10-3; PETRIE, *Kahun, Gurob, and Hawara*, pl. v, cf. p. 15.

Finds.

Red granite block with titles of King, found near Pyramid; text, CHABÂN, *Fouilles à Achmounéîn* in *Ann. Serv.* viii. 223 [v].

Labyrinth. Amenemhêt III.

South of Pyramid.

See L. D. *Text*, ii, pp. 13-24; VASSALLI, *Rapport sur les fouilles du Fayoum* [&c.] in *Rec. de Trav.* vi. 39-41; PETRIE, *Hawara, Biahmu, and Arsinoe*, pp. 4-8; PETRIE, WAINWRIGHT, and MACKAY, *The Labyrinth, Gerzeh and Mazghuneh*, pp. 28-33. Plan, id. ib. pl. xxxii, cf. restoration, p. 29; PETRIE, *Hawara* [&c.], pl. xxv [right]. Sections of granite and limestone columns, and view, L. D. i. 47 [lower right], 48, and *Text*, ii, pp. 16-17.

Fragments of architraves and pillars with names of Amenemhêt III, and of his daughter, Queen Sebekneferurê', L. D. ii. 140 a-i, and *Text*, ii, pp. 15, 19-20. Another fragment with name of Queen, PETRIE, *Kahun, Gurob, and Hawara*, pl. xi [1].

Two red granite shrines with two figures of Amenemhêt III, found near Pyramid base; one in Copenhagen, Ny Carlsberg Mus., Æ.I.N. 1482, PETRIE, WAINWRIGHT, and MACKAY, *The Labyrinth* [&c.], pl. xxiii, cf. pp. 30-1; MOGENSEN, *La Collection égyptienne*, pl. ii [A 4], cf. p. 6; one in Cairo Mus., EVERS, op. cit. i, p. 111, Abb. 27; see MASPERO, *Guide* (1914), p. 146.

Remains of limestone statues of Ḥathor, Sobk, Amenemḥet III, &c., found near last, PETRIE, WAINWRIGHT, and MACKAY, op. cit. pls. xxiv, xxv, cf. p. 31.

Statue of Amenemḥet III, found on west side, in Cairo Mus. 385, BORCHARDT, *Statuen und Statuetten* (Cat. Caire), ii, pl. 61, pp. 4-5; EVERS, op. cit. i, pls. 102-4; BISSING, *Denkmäler*, 24; MASPERO, *Le Musée Égyptien*, ii, pl. xv, pp. 41-2; id. *Guide* (1914), p. 94, fig. 28; MASPERO and ROEDER, *Führer* (1912), pls. 17 [b], 18; CAPART, *L'Art Égyptien* (1909), pls. 36, 37; STEINDORFF, *Die Kunst der Ägypter*, p. 201; upper part, BORCHARDT and REISNER, *Works of Art*, pl. 6; WEIGALL, *Anc. Eg. Works of Art*, 95; BOREUX, *L'Art Égyptien*, pl. xxxii; ENGELBACH, *The so-called Hyksos Monuments in Ann. Serv.* xxviii, pl. ii [3], cf. pp. 22, 27; D[OWS] D[UNHAM], *An Egyptian Portrait Head of the XII Dynasty in Boston Mus. Bull.* Aug. 1928, p. 62 [3], cf. 64; see PETRIE, WAINWRIGHT, and MACKAY, *The Labyrinth* [&c.], p. 29.

Fragments of red granite colossus, found near south-east corner of Pyramid, id. ib. pl. xxvii [upper left], cf. p. 31.

Block with figures of two crocodiles, found at south-east corner of Pyramid, id. ib. pl. xxvii [middle right], cf. p. 31.

Fragments of statue-group, Amenemḥet III with two Faiyûm goddesses on either side, id. ib. pl. xxvi, cf. p. 31.

Limestone block with names and titles of Amenemḥet III, in Brit. Mus. 1072, *Hiero. Texts* [&c.], Pt. iv, pl. 15; see *Guide*, Sculpture (1909), p. 50 [171].



Block with names of Sobk, found north of Pyramid, PETRIE, WAINWRIGHT, and MACKAY, op. cit. pl. xxvii [top right], cf. pp. 31-2.

Remains of sculptures, id. ib. pls. xxvii [bottom right], xxviii [lower left], xxix [right], cf. p. 32; fragment with cartouche of Amenemḥet III [=xxviii (lower left)], in Copenhagen, Ny Carlsberg Mus., Æ.I.N. 1410, MOGENSEN, *La Collection égyptienne*, pl. ci [A 700], cf. p. 94.

Two statue-bases of Amenemḥet III, PETRIE, WAINWRIGHT, and MACKAY, op. cit. pl. xxviii [right], cf. p. 32.

Statue of Kha'emtar , Lieutenant of chariotry, Dyn. XIX, in Manchester Mus., PETRIE, *Roman Portraits and Memphis* (iv), pl. xix [1], cf. p. 21; text, PETRIE, WAINWRIGHT, and MACKAY, op. cit. pl. xxxviii [3], cf. p. 36.

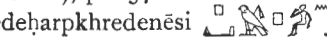
Offering-table of Pedēsi , Ptolemaic, in Cairo Mus. 23235; text, KAMAL, *Tables d'Offrandes* (Cat. Caire), p. 157.

Offering-table of Pedeharphkredenēsi  and brother Pedusiri , Ptolemaic, in Cairo Mus. 23240, id. ib. pls. li, lii, pp. 159-61.

CEMETERIES NORTH OF PYRAMID

See *L. D. Text*, ii, pp. 28-9; PETRIE, *Hawara* [&c.], pp. 8-13.

Middle Kingdom Tombs.

Statue-base with titles of Amenemḥet III from a tomb, in Berlin Mus. 1195; texts, *L. D.* ii. 1401; *Aeg. Inschr. Mus. Berlin*, i. 152, 269, cf. *Ausführ. Verzeichnis* (1899), p. 86.

Fragment of relief of Puu , Prophet of Neith, with son, perhaps Middle Kingdom, built into Ptolemaic wall, now in Brit. Mus. 1042; text, PETRIE, op. cit. pl. vi [3], cf. p. 8; see *Guide*, Sculpture (1909), p. 235 [847].

Rock-tombs. Dyn. XII re-used Dyn. XXIII.



See *L. D. Text*, ii, p. 29; PETRIE, WAINWRIGHT, and MACKAY, *The Labyrinth* [&c.], pls. xxx, xxxi, pp. 35-6; plans, id. ib. pl. xxxvii.

Funeral furniture of Sit-rennut, Middle Kingdom, in London, Univ. Coll., id. ib. pl. xxx [left], cf. pp. 35-6.

Canopic jars of Iu-nūfer (?) , Middle Kingdom, in Copenhagen, Ny Carlsberg Mus., Æ.I.N. 1385, id. ib. pl. xxxi [left]; MOGENSEN, *La Collection égyptienne*, pl. lxxiii [A 569], cf. p. 73.

Coffin of Bebut ; texts, PETRIE, WAINWRIGHT, and MACKAY, op. cit. pl. xxxvii [bottom], cf. p. 35.

Saite and Ptolemaic Tombs.

ḤARWOZ  , Prophet of Neith. Dyn. XXVI.

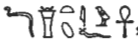

See PETRIE, *Hawara* [&c.], pp. 8-9 [12]; id. *Kahun* [&c.], pp. 8-10, 18-20. Plan, id. ib. pl. vii [11].

Recess.

Canopic jars of two brothers, both called Zeubastef'onkh , Prophets of Neith, &c., sons of Ḥarwoz; texts, PETRIE, *Hawara* [&c.], pl. iv, cf. pp. 9, 23.

Sarcophagus Chambers.









Canopic jars of Ḥarwoz; texts, id. *Kahun* [&c.], pl. xxiv [28-31].



'ANKHRUI  or , Mayor of the Faiyūm. Dyn. XXX.

Coffin, in Cairo Mus., id. *Hawara* [&c.], pls. i-iii, cf. pp. 9 [13], 21-3.

Fragments of coffin of 'Ankhefenmut   , Prophet of Neith, &c., found near it; texts, id. ib. pl. v [9], cf. pp. 9, 23.

Various.

Coffins of Herpa , Paēsi , Dusobk (?) , a son of Nema'etrē' (Marres) , Pedehor-pshenēsi , Atem(?)hotp , Ta-Amūn , and pectoral of Nekhtre' , Ptolemaic; texts, id. ib. pl. v [1-8, 10-12], cf. pp. 9, 23.

Offering-tables, Ptolemaic, of Ma'etemakhet  and of Nema'etrē' (Marres) , latter in Oxford, Ashmolean Mus., id. ib. pl. vi [1, 2].

Inscribed fragments (No. 4 in Oxford, Ashmolean Mus.), Middle Kingdom, Dyn. XX, XXVI, &c., id. ib. pl. vi [4-6, 9-12], cf. p. 8 [10].







Stela of Pedesobk , Prophet of Neith, Ptolemaic, in Cairo Mus.; texts, DARESSY, *Une stèle de Hawara* in *Rec. de Trav.* xxxvi. 73-82.



CROCODILE-CEMETERY

Five hundred metres north-east of Pyramid.

Tomb-chapels. Dyn. XII.

See PETRIE, *Kahun* [&c.], pp. 17-18. Plans, id. ib. pl. vii [1-10].

Three blocks from tomb of Ameny-senb-nebuu      , Regulator of a guild, id. ib. pl. xi [2-4].

Block from tomb of Renef'ankh   , id. ib. pl. xi [9].

Other fragments from tombs, PETRIE, *Hawara* [&c.], pl. vi [13], cf. p. 10 [14]; id. *Kahun* [&c.], pl. xi [5-8].

Later Burials. Dyn. XX-XXVI.

Wooden coffin-lids of divine fathers; texts, id. ib. pl. xxv [19, 20], cf. p. 18.

ROMAN CEMETERY

See PETRIE, *Roman Portraits and Memphis (iv)*, pp. 1-23, pls. i-xxvi.

Two altars, one with offering-bringers and *ba*-bird, the other (in Copenhagen, Ny Carlsberg Mus.) with offering-scenes before Osiris, Isis, and Nephthys, id. ib. pl. xix [4-7], cf. p. 21 [46].

SEILA

PYRAMID. Dyn. III (?). At Gebel el-Rûs.

Views, BORCHARDT, *Die Pyramide von Silah* in *Ann. Serv.* i, pp. 211, 213, 214, figs. 1, 3, 4.

FINDS.

Painted statue of man, and painted double-statue of man and woman, Old Kingdom, in Cairo Mus. 5, 6, BORCHARDT, *Statuen und Statuetten* (Cat. Caire), i, pl. 2, cf. pp. 6-7.

TELL UMM EL-BREIGÂT (TEBTUNIS)¹

TEMPLE. Early Ptolemaic.

See *Chronique d'Égypte*, Jan. 1932, 85-8; ANTI, BAGNANI, and FIOCCO, forthcoming publication.

TOWN.

Plans and views, ANTI, *Un Esempio di Sistemazione Urbanistica nel III secolo av. Cr.* in *Architettura e Arti Decorative*, x (1930), figs. 1-13; id. *Archeologia d'oltremare* in *Atti del R. Istituto Veneto*, xc [2], p. 1060 et seq., xci [2], p. 1183 et seq.

FINDS.

Objects, including memorial stone of Horus on the crocodiles, bronze statuettes, diorite head of statue, ushabti, &c., in California Mus., LUTZ, *Egyptian Statues and Statuettes*, pls. 2 [b], 3 [b], 4-7, 9 [a], 10, 11 [a], 12-14.

Miscellaneous.

(From El-Faiyûm, but exact provenance unknown.)

Statue of Per-her-*nefert* $\square \diamond \dagger \overset{\circ}{\circ}$, Royal acquaintance of the Great House, Dyn. V or VI, in Berlin Mus. 10858, *Ausführ. Verzeichnis* (1899), p. 67, Abb. 9; *Aeg. und Vorderasiat. Alterthümer*, pl. 6; BISSING, *Denkmäler*, II A [a]; CAPART, *L'Art Égyptien* (1911), pl. 113; CURTIUS, *Antiker Kunst*, p. 83, Abb. 77; head, CAPART and WERBROUCK, *Memphis*, p. 347, fig. 332; text, *Aeg. Inschr. Mus. Berlin*, i. 70.

Inscribed blocks of Sesostris III, from temple wall, in Berlin Mus. 15801-15804, id. ib. 138, cf. 268.

Fragment of offering-table of Amenemhêt III, in Cairo Mus. 20699; texts, LANGE and SCHÄFER, *Grab- und Denksteine* [&c.] (Cat. Caire), ii, p. 327.

Fragment of base of statue of Amenemhêt IV, in Cairo Mus. 769; text, BORCHARDT, *Statuen und Statuetten* (Cat. Caire), iii, p. 81.

Porphyry statue of King Neferhôtep I, Dyn. XIII, evidently from here, in Bologna Mus. 1799, ROSELLINI, *Mon. Stor. Text*, ii, pl. xiii [152]; L. D. iii. 291 [20, 21];

¹ For great finds of Greek and demotic papyri, discovered in wrappings of crocodile mummies, see GRENFELL and HUNT, *Tebtunis Papyri*, vols. i-iii already published, and SPIEGELBERG, *Die demotischen Papyrus* (Cat. Caire).

BISSING, *Denkmäler*, 28 A [a, b] and *Text* [fig.]; PETRIE, *A History of Egypt*, i (1923), pp. 221, 222, figs. 127, 128; text, IDELER, *Hermapion* (1841), pl. xxvi [10]; NAVILLE, *Un fonctionnaire de la XIII^e dynastie* in *Rec. de Trav.* i. 109; KMINÉK-SZEDLO, *Catalogo di Antichità Egizia* (1895), 146-7; see GAUTHIER, *Le Livre des Rois*, ii. 26 [xvii].

Scribe's palette of Ithu , temp. Apophis I (?), in fragments, in Berlin Mus. 7798, *Aeg. und Vorderasiat. Alterthümer*, pl. 37 [middle left]; one fragment, MASPERO, *Hist. Anc. des peuples de l'Orient, Les Premières Mèlées*, p. 57; text, *Aeg. Inschr. Mus. Berlin*, i. 264-5, cf. *Ausführ. Verzeichnis* (1899), p. 217; see EISENLOHR, *An Historical Monument* in *P.S.B.A.* iii. 97.

Black granite squatting statue of Sebkhōtp , Mayor and Chief in the Faiyûm, temp. Tuthmosis IV, in Marseilles Mus. 8, NAVILLE, op. cit. plate opposite p. 110, cf. 107-9; CAPART, *Recueil de Mon. Ég.* lxxiii, cf. description of plates; see MASPERO, *Catalogue du Musée Égyptien de Marseille*, pp. 6-7; titles, BRUGSCH, *Der Möris-See* in *Ä.Z.* xxxi. 20 [bottom].

Boundary stela, year 2 of Sethos I; texts, DARESSY, *Notes et remarques* in *Rec. de Trav.* xiv. 38 [lviii].

Lintel and jamb of Hōri , Priest, Scribe of the troops, temp. Ramesses IX, in Cairo Mus. 29334, 29335; texts, DARESSY, op. cit. 28 [xxxvii, xxxviii].

Small stela, Peduser-perē  kneeling before Darius I as hawk, in Berlin Mus. 7493, BURCHARDT, *Datierte Denkmäler* [&c.] in *Ä.Z.* xlix, pl. viii [1], cf. p. 71; see *Ausführ. Verzeichnis* (1899), p. 255.

Sarcophagus of Setyerboni , Dyn. XXVI-XXX, in Cairo Mus. 31154; text on lid, SPIEGELBERG, *Die demotischen Inschriften* (Cat. Caire), p. 62.

Fragment of bas-relief with demons and offering-bringers, Late Period, RIFAUD, *Voyage*, 135 [3].

Stela of Dhout , son of Ta-Amūn , Ptolemaic or Roman, in Cairo Mus. 22197, KAMAL, *Stèles Ptolémaïques et Romaines* (Cat. Caire), pl. lxix, p. 193.

Ptolemaic stela, in Cairo Mus. 22162, id. ib. pl. xlix, p. 147.

Headless statue of Unnūfer , Priest, &c., Late Period, in Cairo Mus. 688, BORCHARDT, op. cit. iii, pl. 126, pp. 31-2; text, DARESSY, *Statues de basse époque du Musée de Gizéh* in *Rec. de Trav.* xv. 156 [4].

Sun-clock, Late Period, in Berlin Mus. 19743, BORCHARDT, *Altägyptische Sonnenuhren* in *Ä.Z.* xlvi, pl. i opposite p. 12; text, *Aeg. Inschr. Mus. Berlin*, ii. 309.

VII. BETWEEN EL-FAIYÛM AND BENI ḤASAN

(ABÛŞĪR EL-MALAQ TO ZÂWYET EL-MAIYITĪN)

WEST BANK



ABÛŞĪR EL-MALAQ, perhaps 

TEMPLE OF PTAḤ-SOKARI-OSIRIS. Nektanebos II (Nekht-ḥar-ḥebi). Beneath mosque in village.

Blocks, some found *in situ*, now built into mosque, MÖLLER, edited by SCHARFF, *Das vorgeschichtliche Gräberfeld von Abusir el-Meleg* in *Wissenschaftliche Veröffentlichung der Deutsch. Or. Gesell.* (1926), pl. 77, cf. p. 102.

CEMETERY. Predynastic, re-used Hyksos Period, Saite, and Graeco-Roman.

See MÖLLER, *Ausgrabung der Deutschen Orient-Gesellschaft auf dem vorgeschichtlichen Friedhofe bei Abusir el-Meleq im Sommer 1905* in *Mitteil. d. Deutsch. Or. Gesell.*, May 1906, No. 30, passim; MÖLLER, edited by SCHARFF, op. cit. in *Wissenschaftliche Veröffentlichung der Deutsch. Or. Gesell.* (1926), passim; later graves, RUBENSOHN and KNATZ, *Bericht über die Ausgrabungen bei Abusir el Mäläq im Jahre 1903* in *Ä.Z.* xli, pp. 1-21, Abb. 1-15, with plan, p. 20, Abb. 17.

Sarcophagus of Pethenafi  or , Saite, in Strasbourg Mus.; text, id. ib. p. 21.

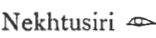
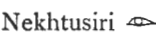
Coffins of Nekhtusiri  and Tazab , Dyn. XXX (?), PETRIE, *Illahun, Kahun and Gurob*, pl. xxviii [middle and right].

Offering-table, in Berlin Mus. 17038, SETHE, *Die Namen von Ober- und Unterägypten und die Bezeichnungen für Nord und Süd* in *Ä.Z.* xlv. 29.

EL-HARAGA

CEMETERIES

Predynastic, Dyn. V-XI, XII, XVIII, and Roman.

ENGELBACH and GUNN, *Harageh*, passim. Plan of site, id. ib. pl. ii. Plans showing positions of tombs, id. ib. pls. iii-v, cf. pp. 2-3, 6-18.

DOUBLE-TOMB OF HARSHEFNAKHT  and UKH(T)HOTP .

Before Dyn. XII. (Nos. 671, 672.)

Id. ib. p. 14 [65].

Sepulchral Chambers.

Walls. Ritual scenes, offerings, and religious texts, id. ib. pls. lxviii, lxvii, cf. pl. vi [6], pp. 20-3 [83, 84].

TOMB OF ITENḤAB , Lady of the House. Dyn. XII. (No. 124.)

Plan, id. ib. pl. xiii [5]. Inlaid jewellery with name of Sesostris II, id. ib. pl. xv [2], cf. pp. 15-16 [69].

Inner Room.

Stela, in Copenhagen, Ny Carlsberg Mus., Æ.I.N. 1664, id. ib. pls. xvi [2], lxxiii, cf. pp. 28-9 [93] with note 6; MOGENSEN, *La Collection égyptienne*, pl. xcvi [A 687], cf. p. 92.

TOMB OF SENEPTISI , Lady of the House. Middle Kingdom.







(No. 92.)

Canopic jars; texts, ENGELBACH and GUNN, op. cit. pl. lxxv [2, 3], cf. pp. 15 [68], 29 [97].

TOMB OF SENUSERT-'ANKH , Dyn. XII. (No. 250.)

Coffin and canopic box; texts, id. ib. pls. lxx, lxiv [1], cf. pp. 23-4 [85], 26 [88, 1].

VARIOUS.

Coffins of Im'abim , Dyn. III-IV, an 'Asiatic', Iti  (usurped from Neferunt . . . , Sitimpi (?) , Mereri , Thau , Ihynes

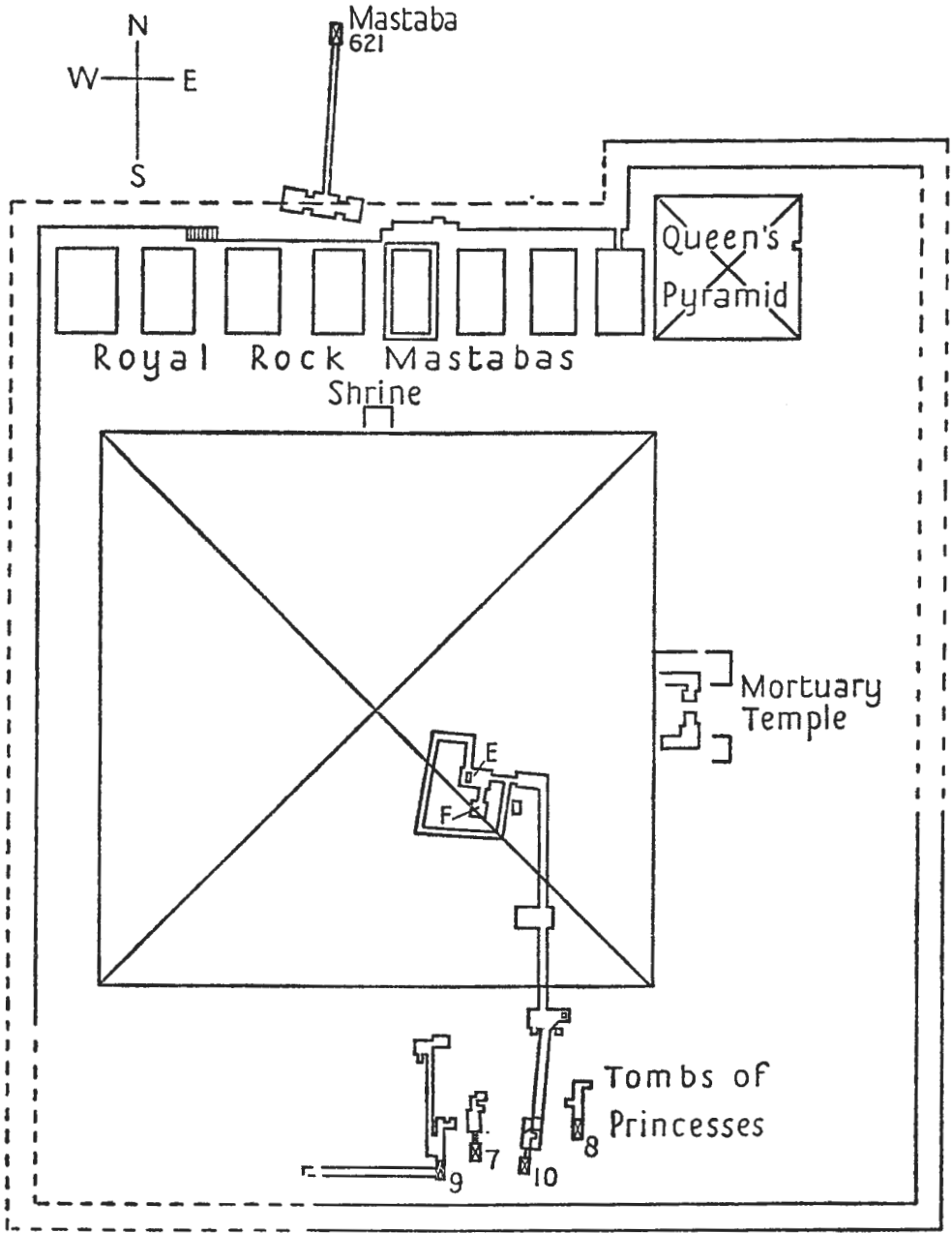

EL-LÂHÛN. PYRAMID. SESOSTRIS II.
From PETRIE, BRUNTON and MURRAY, *Lahun*, ii, pl. viii.

𓆎𓆎𓆎𓆎𓆎, Hesy 𓆎𓆎𓆎, and Ḥarhotp (?) 𓆎𓆎𓆎. Middle Kingdom ; texts, id. ib. pls. lxxiv [1], lxxv [1], lxv, lxxvii [1-5, 7], cf. pp. 24-5 [87].

Painted coffins (no names), Middle Kingdom ; texts and decoration, id. ib. pls. lxvi, lxix, cf. pp. 24 [86], 25.

Canopic box of Iamyt 𓆎𓆎𓆎𓆎𓆎, Lady of the House ; texts, id. ib. pl. lxiv [2], cf. p. 26 [88, 2].

Stelae of Nebpu 𓆎𓆎𓆎, another Nebpu 𓆎𓆎𓆎, Ḥaremḥab 𓆎𓆎𓆎, Khentekhtiem-saf-sonb 𓆎𓆎𓆎𓆎𓆎, Kenemsu 𓆎𓆎𓆎 and Seruket 𓆎𓆎𓆎, Renefsonb 𓆎𓆎𓆎, Dyn. XII, Thayt (?) 𓆎𓆎𓆎 with Tiuy (?) 𓆎𓆎𓆎, Dyn. XIX, id. ib. pls. lxxi, lxxii, lxxiv [3, 4], lxxv [5], lxxvi [1], xvi [1], xxiv, cf. pp. 26-8 [89-92], 29 [94-6] ; of first Nebpu and Khentekhtiem-saf-sonb [ENGELBACH and GUNN, lxxi, lxxii (3)], in Copenhagen, Ny Carlsberg Mus., Æ.I.N. 1540, 1539, MOGENSEN, op. cit. pls. xcvi [A 682], xcvi [A 688], cf. pp. 91, 92.

Pair of statuettes, man and Kemtet 𓆎𓆎, and head-rest of Ihyes 𓆎𓆎𓆎, Old Kingdom, ENGELBACH and GUNN, op. cit. pls. i, xviii, viii [6], cf. pp. 12-13 [55], 8, 29.

Granite statuette of Shesmuḥotp 𓆎𓆎𓆎, Overseer of the Cabinet, and offering-table from same tomb, Dyn. XI, id. ib. pl. xix [1, 2], cf. pp. 13 [56], 29 [98].

Statuette-base of Seneny 𓆎𓆎𓆎 ; text, id. ib. pl. lxxiv [2], cf. p. 29 [98].

Uninscribed wooden and stone statuettes, Dyn. XII and XIII, id. ib. pls. xvii [1], xix [3, 4], xxv [bottom left], cf. pp. 12 [53], 13 [56, 60].

Two pots with religious texts in hieratic, Hyksos period ; texts, id. ib. pls. lxxviii, lxxix, cf. pp. 30-1.

Inscriptions on pottery, id. ib. pl. lxxx, cf. p. 32.

EL-LÂHÛN

Plan of site, L. D. i. 44 [lower] ; PETRIE, BRUNTON, and MURRAY, *Lahun*, ii, pls. ii, iii.

Pyramid (𓆎𓆎) 𓆎. Sesostri II.

See id. ib. pp. 2-14, pls. i, iv-vii, x ; PETRIE, *Illahun, Kahun, and Gurob*, pp. 1-5 ; BRUNTON, *The British School at Lahun in Anc. Eg.* (1914), pp. 49-51 ; description, L. D. *Text*, ii, pp. 7-8 ; BURTON MSS.* 25618, 20. Plan, PETRIE, &c., *Lahun*, ii, pl. viii. View, DENON, *Voyage* (1802), 26 [1] ; L. D. i. 50 [upper].

VALLEY TEMPLE.

See PETRIE, *Kahun, Illahun, and Gurob*, pp. 21-3 ; id. *Lahun*, ii, pp. 39-40. Plan, id. *Kahun* [&c.], pl. xv [bottom left] ; id. *Lahun*, ii, pl. xxxiii.

Foundation deposit, in London, Univ. Coll., id. *Kahun* [&c.], pl. xiv [upper].

Fragment of sculpture, id. *Lahun*, ii, pl. lxix [2, 4-10].

MORTUARY TEMPLE, on east side of Pyramid.

See id. *Kahun* [&c.], pp. 21-3. Plan, id. ib. pl. xv [bottom].

Fragments of sculpture, id. *Lahun*, ii, pls. xvi, xviii, xix, xxxvi [55], cf. p. 5 ; head of Sesostri II [= xviii (upper right)], *Anc. Eg.* (1914), fig. on p. 144.

Fragment of offering-list, found in town, PETRIE, *Illahun* [&c.], pl. xii [9], cf. p. 13.

PYRAMID.

Plan, section, and view, PERRING, *The Pyramids of Gizeh*, Pt. iii, pl. xviii, figs. 1, 2 ;

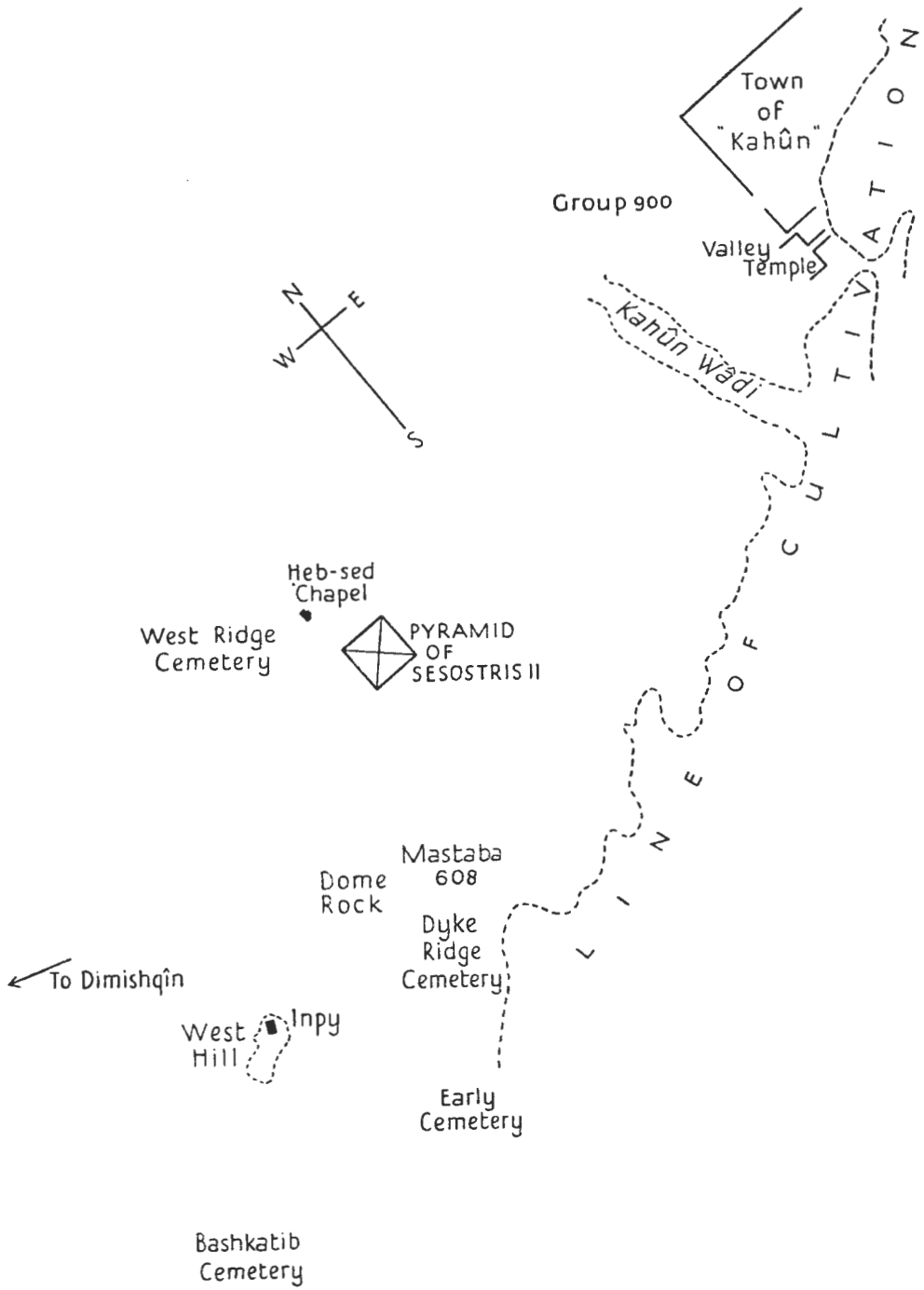

EL-LÂHÛN. KEY-PLAN.

From PETRIE, BRUNTON and MURRAY, *Lahun*, ii, pl. ii.

plan and section of interior, PETRIE, *Illahun* [&c.], pl. ii. View of sarcophagus chamber, id. *Lahun*, ii, pl. xxv [5], cf. pp. 6-7 [11]; CAPART, *L'Art Égyptien*, i, *L'Architecture*, pl. 66.

Fragments of black granite pyramidion, found among chips in centre of south side, PETRIE, *Lahun*, ii, pl. xxiv [bottom], cf. p. 4 [6].

Sarcophagus Chamber E.

Alabaster offering-table, in Cairo Mus. 23043, id. *Illahun* [&c.], pl. iii, cf. p. 4 [10]; KAMAL, *Tables d'Offrandes* (Cat. Caire), p. 38.

Offering Chamber F.

Gold uraeus from King's crown, in Cairo Mus. 52702, PETRIE, *Lahun*, ii, pl. xxv [1-4], cf. pp. 12-13; id. *The British School of Archaeology* [&c.] in *Anc. Eg.* (1920), plate opposite p. 65 [upper]; id. *Seventy Years in Archaeology*, plate opposite p. 240; VERNIER, *Bijoux et orfèvreries* (Cat. Caire), pl. xlvii, cf. p. 235.

Shrine on north side of Pyramid.

Fragments of sculpture, PETRIE, *Lahun*, ii, pl. xvii [top], cf. p. 5.

SMALL PYRAMID. QUEEN ATEMU[NEFERU (?)] 

See id. ib. pp. 8-9, pls. x [upper], xii. Plans, id. ib. pls. xi [upper], xxiv [middle]. Foundation deposit, in Bristol, id. *Illahun* [&c.], pl. iv [upper], cf. p. 5.

Shrine on north side.

Fragments of painted walls and of black granite altar, id. ib. pl. xii [6-8], cf. pp. 4-5 [12], 13; fragments, id. *Lahun*, ii, pl. xvii [lower left], cf. p. 8 [15].

Tombs of Princesses, south of Pyramid. (7-10 of PETRIE.)

See id. ib. i, pp. 8-22, ii, pp. 7 [12], 14-16. Plans, id. ib. ii, pl. xxii, cf. xxiii; i, pls. xxi, xxii. Views, id. ib. i, pls. xvi, xvii.

TOMB OF SIT-HATHOR-INT . (8 of PETRIE.)

See LYTHGOE, *The Treasure of Lahun* in *N. Y. Metro. Bull.* Pt. ii, Dec. 1919, pp. 7-28, figs. 3-25. Plan and section, PETRIE, *Lahun*, i, pl. xxii [top right]; LYTHGOE, op. cit. p. 10, fig. 3 (after PETRIE).

Sepulchral Chamber.

View, PETRIE, op. cit. i, pl. xvi; LYTHGOE, op. cit. p. 11, fig. 4.

Jewellery, including crown, pectoral of Amenemhêt III, and mirror, in Cairo Mus. 52641, 52712, 52663, and pectoral of Sesostri II, casket, anklets, and armllets, in New York, Metropolitan Mus., PETRIE, *Lahun*, i, pls. i (frontispiece), iv, v, vi, xi [1, 2, 5], xii, pp. 22-44; LYTHGOE, op. cit. cover, frontispiece, figs. 6-8, 11, 15, 21, 23-5, pp. 13-27; pectorals and armllets, PETRIE, *The Treasure of Lahun* in *Anc. Eg.* (1914), plate opposite p. 97; pectoral of Amenemhêt III, mirror, and crown, id. *Seventy Years in Archaeology*, plates opposite pp. 230, 232, 234; VERNIER, op. cit. pls. xxxviii, xlvii, pp. 201, 213, 239; pectorals and crown, PEET in ROSS, *The Art of Egypt through the Ages*, p. 147, cf. 27; pectoral of Amenemhêt III, necklace, and girdles, WINLOCK, *Notes on the Jewels from Lahun* in *Anc. Eg.* (1920), pp. 75, 79, 85, figs. 1, 5, 8; pectoral, HILDA PETRIE, *The British School of Archaeology in Egypt* in *J.E.A.* i, pl. xxix [2].

Canopic jars, PETRIE, *Lahun*, i, pls. xiv, xv [upper left], cf. pp. 19-20 [27]; LYTHGOE, op. cit. p. 25, fig. 22.

Inscribed alabaster jar in offering chamber, PETRIE, *Lahun*, ii, pls. xxv [7], xxvi, cf. pp. 15-16 [32]; id. *The British School of Archaeology* [&c.] in *Anc. Eg.* (1920), plate opposite p. 65 [lower].

Inscribed fragment of black granite, found in débris round sarcophagus, id. *Lahun*, i, pl. xv [middle right], cf. p. 20 [29].

Royal Rock-mastabas, north of Pyramid.

Views, id. ib. ii, pls. vii, x [lower].

Fragments of sculpture, id. ib. pl. xvii [lower right], cf. p. 10 [18].

Mastaba 621.

Granite sarcophagus in chamber, id. ib. pl. xxv [6], cf. pp. 7-8 [13].

Ḥeb-sed Chapel (?), north of Pyramid.

See id. ib. pp. 2, 18-20. Plan, id. ib. pl. xx.

Fragments of sculpture, id. ib. pl. xxi.

NECROPOLIS

Protodynastic, Dyn. I-III, VI-IX, XII, XVIII, XXII-XXIV and Roman.

See id. ib. ii, pp. 24-39, and plates passim.

'Group 900'. Dyn. XII.

See id. ib. p. 31. Plan, id. ib. pl. xiii [middle left].

TOMB OF KHENEMSKHRED  (906 of PETRIE.)

First Room.

West wall. Offering-table in front of recess, id. ib. pl. xxxvi [1], cf. p. 31.

TOMB OF SENUSERT . . .  (905 of PETRIE.)

Inscribed fragments of frieze and cornice of stela, id. ib. pl. xxxvi [2-12], cf. p. 30.

Kahûn Wâdi.

TOMB 107. Dyn. XII.

Fragments of coffin, id. ib. pl. xxxv [lower], cf. pp. 24 [52], 31 [73].

West Ridge Cemetery.

MASTABAS. Dyn. XII, re-used Dyn. XVIII and XXII.

Plans, id. ib. pls. xxxvi A, xxvii [upper].

Fragments of sculpture from mastabas 601, 602 (tomb), 607, 609, 618, 626, id. ib. pls. xxxiv, xxvii [upper middle], cf. pp. 28-30, 31.

Trial-pieces, King's heads and hawks, from tomb 603, id. ib. pl. xxxii [middle], cf. p. 37 [90].

West Hill.

MASTABA OF INPY , Chancellor of the King of Lower Egypt ; Overseer of every royal work ; Overseer of the Gate (or Judgment-hall) ; &c. Dyn. XII. (620 of PETRIE.)

Plan and sections, id. ib. pl. xxvii [lower], cf. pl. xiii [bottom], pp. 26-7.

Hall.

View, id. ib. pl. xliv [6].
Fragments of sculptures, id. ib. pls. xxviii-xxxI, cf. p. 27 [64].
Statue; text, id. ib. pl. xxxI [74].

Dome Rock.

TOMB OF 'ANKHMESU. Dyn. XII, re-used Dyn. XVIII and XXII.

Coffin, see id. ib. pp. 32-3.



Dyke Ridge Cemetery. Dyn. XXII-XXV.











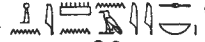



See PETRIE, *Illahun* [&c.], pp. 24-8, cf. pl. xxix.



TOMB OF AMENARDAIS .

In Cairo Mus., see id. ib. p. 27 [50].
Coffin; texts, id. *Kahun* [&c.], pl. xxvi.

VARIOUS.

Coffins of Hetepti , Great steward, Puu , and Esweben (?) ; texts, id. *Illahun* [&c.], pls. xxiv [13], xxviii [left]; text of Puu, id. *Kahun* [&c.], pl. xxv [17].

Coffins of Inamûn-nesnebu , Pima (?) , Duaneteref , Tasadi , 'Ankh-Hor , Pemû , Nakhtubasterau , Harwoz  (lid only), Tere , Yewerhen , Unnûfer , Bekren , 'Ankh-hap , Sekhmet , Arensekhmet ; texts, id. ib. pl. xxv [4, 6-16, 18, 21-30], cf. p. 40.

Coffins and inscribed belt of Tate (?)  and Tabam (?) , both Singers of Amûn; texts, id. ib. pl. xxv [1-3, 5]; see id. *Illahun* [&c.], pp. 26-7.

Mastaba 608.

Plan, id. *Lahun*, ii, pl. xxvii [left], cf. p. 28 [66].
Sculptures, id. ib. pl. xxxvi [13-53].

Early Cemetery and Bashkatib Cemetery. Predynastic and Dyn. I-III.

See id. ib. pp. 21-4, 25, cf. pls. xli-xliii, xlv [1-5], xlv-xlvi. Plan, id. ib. pl. xl.

Dimishqîn Cemetery. Old Kingdom or Dyn. IX.

See id. ib. pp. 25-6 [59], and pls. xxiii [bottom left], xlvii.

TOWN ('KAHÛN'). Dyn. XII.

See PETRIE, *Kahun* [&c.], pp. 23-32; id. *Illahun* [&c.], pp. 5-8; id. *Lahun*, ii, pp. 39-40, 41. Plans, id. *Kahun* [&c.], pl. xv; id. *Illahun* [&c.], pl. xiv; id. *Lahun*, ii, pl. xxxvi A [bottom right]. Views of shrine, id. ib. pl. xlv [7, 8]. Restorations, id. *Illahun* [&c.], pl. xvi [1-3].

Inscribed objects and fragments, id. *Kahun* [&c.], pls. x, xi [11-15]; blue glaze fragment, King Wehebrê', Dyn. XIII [= *Kahun*, x (72)], see GAUTHIER, *Le Livre des Rois*, ii. 43 [iv].

Wall-paintings in houses representing a temple and house, PETRIE, *Illahun* [&c.], pl. xvi [4-6], cf. p. 7.





FAMILY-TOMB OF MAKET  Dyn. XVIII.

See id. ib. pp. 21-4, pls. xxvi, xxvii, cf. plan, pl. xiv [right]; BISSING, *Die Datirung des 'Maket-Grabes'* in *A.Z.* xxxv. 94-7.

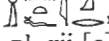

VARIOUS

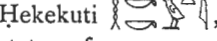
Statue of Sisobk , Royal acquaintance, Middle Kingdom, found in a house, now in Cairo Mus. 405, BORCHARDT, *Statuen und Statuetten* (Cat. Caire), ii, pl. 66, pp. 17-18; texts, PETRIE, *Illahun* [&c.], pl. xii [14], cf. p. 13.

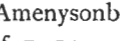
Lower part of statue of Antefoker , Chancellor of the King of Lower Egypt, Chief steward, Dyn. XII; text, id. ib. pl. xii [1], cf. p. 13.

Stela of Meri'ankh , stela of Is , statue of Heshneb (?) , stela of Hekekuti , statue of Ipwer (?) , stela of Amenysonb , and statue of a woman; texts, id. ib. pl. xii [2-5, 10, 12-13], cf. p. 13.

Fragments of stela of Inpy , in Chicago Mus., id. *Kahun* [&c.], pl. xi [10]; id. *Illahun* [&c.], pl. xii [11], cf. p. 13.

Part of stela of Senusert , inscription of Khety , statuette of Ay , and inscribed fragment of black granite, id. *Lahun*, ii, pls. xxxv [upper], xlvi [22, 25], lxix [2], cf. pp. 41, 42.

Trial-piece, relief of man with fowl, id. ib. pl. xxxii [2], cf. p. 41 [100].

MISCELLANEOUS

(From El-Lâhûn, but exact provenance unknown.)

Stela of Senusert-'ankhitef (?) , Chief lector, Dyn. XII, re-used in tomb-shaft, now in Cairo Mus., PETRIE, *Illahun* [&c.], pl. xi, cf. p. 13.

Small stela, Middle Kingdom, found in *sebakh*, in Cairo Mus., WAINWRIGHT, *Antiquities from Middle Egypt and the Fayûm* in *Ann. Serv.* xxv, pp. 144-5, and plate [bottom left].

Fragment, Amenophis IV, re-used in a tomb, in Philadelphia, Pennsylvania Univ. Mus., PETRIE, *Illahun* [&c.], pl. xxiv [10], cf. p. 20; BORCHARDT, *Aus der Arbeit an den Funden von Tell el-Amarna* in *Mitteil. d. Deutsch. Or. Gesell.*, March 1917, No. 57, p. 5, Abb. 1; id. *Porträts der Königin Nofret-ete*, p. 16, Abb. 11.

Coffin of priest (?), name lost, Persian (?), in Cairo Mus., MASPERO, *Un cercueil du Fayoum* in *Ann. Serv.* ii, p. 192 and last plate.

KÔM MEDÏNET GHURAB ('GUROB')

See PETRIE, *Kahun, Gurob, and Hawara*, pp. 32-40; id. *Illahun* [&c.], pp. 15-20. Map of district, BRUNTON and ENGELBACH, *Gurob*, pls. i, ii.

TEMPLE OF TUTHMOSIS III. Defaced by Amenophis IV and destroyed by Ramesses II.

Plan, PETRIE, *Illahun* [&c.], pl. xxv; see BRUNTON and ENGELBACH, op. cit. pls. i, ii, cf. pp. 3-4.

Lintel of Tuthmosis III, in Adelaide Mus., Australia, PETRIE, *Illahun* [&c.], pl. xxiv [3], cf. p. 20.

Block, Tuthmosis III, id. *Kahun* [&c.], pl. xxii [2], cf. p. 32.

Granite offering-table of Amenophis III and Teye, in Adelaide Mus., id. *Illahun* [&c.], pl. xxiv [7], cf. p. 20.

Box-lid of Amenophis III dedicated by Teye, block of Amenophis IV, and wooden

cubit of Tut'ankhamûn and 'Ankhesenamûn; texts, id. ib. pl. xxiv [8, 9, 12], cf. p. 20; cartouches of box-lid, in Berlin Mus. 17587, *Aeg. Inschr. Mus. Berlin*, ii. 305.





Fragments of sculptures and inscriptions from temple, one found in tomb-shaft in Cemetery W, BRUNTON and ENGELBACH, op. cit. pls. xviii [3, 4, 6], xlix [4, 5, 10, 11], l [7], cf. pp. 4, 19.



Texts from statuette, tank, and statue, Dyn. XVIII, PETRIE, *Illahun* [&c.], pl. xxiv [1, 2, 6].



Stela, Ra'mes-emperamûn  adoring Tuthmosis III, probably Dyn. XVIII, id. ib. pl. xxiv [11], cf. p. 20.

SMALL CULT-TEMPLE OF TUTHMOSIS III. Dyn. XIX. On outskirts of ancient town, about fifty yards from Temple, but now entirely destroyed and exact position unknown.

Plan, LOAT, *Gurob*, pl. xiv, cf. pp. 1-2.

Stelae, Dyn. XIX, including those of Iay  before Sêth, Ra'meses-emperre' , Peshedu , Na'r , and Pay , found in or near chamber east of Sanctuary, id. ib. pls. xv, xvi [1, 2, 4, 6], xvii [2], cf. pp. 7-8; of Ra'meses-emperre' [LOAT, xv (2)], in Brussels, Musées Royaux du Cinquanteaire, E. 5014, CAPART, *Les Antiquités Égyptiennes*, p. 61, fig. 9; texts, SPELEERS, *Rec. des Inscr. Ég.* 37 [133], cf. 59-60 [249].

Stelae of Senwerui (?) , and of Neb-neteru , found in or near chamber west of Sanctuary, LOAT, op. cit. pls. xvi [3, 5], xviii [1], cf. p. 8; text of Neb-neteru, LEGRAIN, *Répertoire*, No. 194.

Lintel of Ry , Songstress of Amen-rê', and stela of Userma'etrê'-em-hab , LOAT, op. cit. pl. xvii [1, 3].

PALACE (?). Dyn. XVIII.

See BORCHARDT, *Der Porträtkopf der Königin Teye*, p. 3, cf. Abb. 2.

Head of Queen Teye, found at south-west corner, now in Berlin Mus. 21834, id. ib. passim, with four plates; DAVIS, *The Tomb of Queen Tÿyi*, pl. xxxv; SCHÄFER, *Kunstwerke aus El-Amarna*, ii, cover; id. *Amarna in Religion und Kunst*, pl. 10; id. *Kunstwerke aus der Zeit Amenophis IV in Amtliche Berichte*, xxxiv, pp. 129-30, Abb. 63, reprinted in *Ä.Z.* lii, p. 74, Abb. 2; id. *Das Simonsche Holzköpfchen der Königin Teye in Ä.Z.* lxxviii, pl. vi, cf. pp. 81-6; BISSING, *Denkmäler, Text*, fig. on p. v; STEINDORFF, *Die Blütezeit des Pharaonenreichs* (1926), p. 47, Abb. 42; MASPERO, *Egyptian Art*, plate opposite p. 132; WEIGALL, *Anc. Eg. Works of Art*, 205 [right]; KEES, *Kulturgeschichte des Alten Orients*, i, *Ägypten*, pl. 48.

Probably found here.

Three ebony statuettes of Amenophis III, Teye, and prince (on base which probably belonged originally to a statue of Teye), in Hildesheim Mus. 53 a, 53 b, 54, BORCHARDT, op. cit. pp. 14, 15, Abb. 12-14; IPPEL and ROEDER, *Die Denkmäler des Pelizaeus-Museums zu Hildesheim* (1921), pp. 78, 80, Abb. 23, 25.

Part of painted wooden head, probably Amenophis III, and statuette of Queen, in Berlin Mus. 17835, 17836, BORCHARDT, op. cit. pp. 15, 16, Abb. 15, 17.

Bronze statuette of King, perhaps Amenophis IV, and ivory head of statuette, id. ib. p. 16, Abb. 16, 18.

Three wooden stelae of Amenophis III and Teye, two in Berlin Mus. 17959, 17812, id. ib. pp. 18, 19, Abb. 24-6, and p. 20; No. 17812, *Aeg. Inschr. Mus. Berlin*, ii. 393.

TOWN, NORTH OF TEMPLE. Dyn. XVIII to Merneptah.

See PETRIE, *Kahun* [&c.], pp. 32, 33-40; id. *Illahun* [&c.], pp. 16-21.



Tubal kohl-pot with names of Amenophis III and his daughter Isit , in Cairo Mus. 44521, BÉNÉDITE, *Objets de toilette* (Cat. Caire), i, pl. xiii, p. 28; names, LEGRAIN, *Répertoire*, No. 229; see PETRIE, *Kahun* [&c.], pp. 32, 35.

Alabaster vase of Tut'ankhamūn and Queen 'Ankhesenamūn; text, id. ib. pl. xviii [25], cf. p. 35; id. *A History of Egypt*, ii (1926), p. 237, fig. 151.

Groups of objects, temp. Amenophis III (with name of his daughter Hent-tau-neb ) , Tut'ankhamūn, Ramesses II, and Sethos II, PETRIE, *Illahun* [&c.], pls. xvii-xix, cf. pp. 16-18; knob of box-lid of Teye, in Berlin Mus. 20567, *Aeg. Inschr. Mus. Berlin*, ii. 253.

Burials. Late Dyn. XVIII or early XIX.

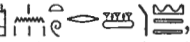
See PETRIE, *Kahun* [&c.], pp. 38, 39.

Coffins of Intersh , and text of box of Sel (?) , Scribe of the Royal Harīm, in Cairo Mus., id. ib. pls. xix, xxiv [1], cf. pp. 36, 38.

Coffin and statuette of Res ; statuette, in Cairo Mus. 814, BORCHARDT, *Statuen und Statuetten* (Cat. Caire), iii, pl. 150, p. 108; text of statuette, PETRIE, *Kahun* [&c.], pl. xxii [8], cf. pp. 38-9.

Pyramidions, and two stelae (one of Nebamūn ) , Dyn. XIX, id. ib. pl. xxii [4-6].

Statuette of priestess, Dyn. XIX, in Cairo Mus. 802, BORCHARDT, op. cit. iii, pl. 148, p. 100; text, PETRIE, *Kahun* [&c.], pl. xxii [7], cf. p. 38.

NECROPOLIS

Protodynastic, Old Kingdom, Dyn. VII-IX, New Kingdom, &c.

See BRUNTON and ENGELBACH, *Gurob*, pp. 2-3, 5-17, with plates passim; LOAT, *Gurob*, pp. 2-8, pls. ii-xiii, xv-xix.

Cemetery D.

TOMB OF MERIRĒ' , Overseer of cattle. Dyn. XVIII.

Plan and section, id. ib. pl. xiii [right].

Two ushabtis, in Brussels, Musées Royaux du Cinquantenaire, E. 3279, 3255, SPELEERS, *Les Figurines Funéraires Égyptiennes*, pl. 23 opposite p. 48; one, LOAT, op. cit. pl. v [11], cf. p. 7.

Cemetery W.

TOMB OF PARA'MESSU , King's son; Vizier. Probably temp. Sethos I.

Sarcophagus (lid in Cairo Mus. 30707), BRUNTON and ENGELBACH, *Gurob*, frontispiece and pl. xxxii, cf. pp. 20-1, 24; one end, ENGELBACH, *The Sarcophagus of Pa-Ramessu from Gurob in Anc. Eg.* (1922), plate opposite p. 1 [upper], cf. pp. 9-13.

Finds.

Fragments of sculpture, Dyn. XVIII and XIX, including part of stela of Ipay , Dyn. XIX, from tombs, BRUNTON and ENGELBACH, op. cit. pls. xlix [1-3, 6-9, 12], 1 [1-6, 8-16], cf. p. 19.

Stela of Hā-thekei (?)  (?), Commander-in-chief of the whole land, Dyn. XXII, found close to Animal Cemetery, LOAT, op. cit. pls. xviii [2], xix, cf. p. 8.

MISCELLANEOUS

(From vicinity of Kôm Medînet Ghurab.)

Tombs.

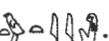
TAMA . Temp. Amenophis III.See QUIBELL, *A Tomb at Hawaret el Gurob* in *Ann. Serv.* ii, pp. 141-3 and two plates.Headrest with cartouche of Amenophis III, and double kohl-pot with cartouches of Amenophis III and Teye, in Cairo Mus. [QUIBELL, pl. i (bottom, middle and right), cf. p. 141 (10, 11)]; cartouches, LEGRAIN, *Répertoire*, Nos. 246, 247.TUTY . Temp. Amenophis III and IV.

Sepulchral Chamber.

Statuettes, inscribed unguent-box, &c.; texts, CHASSINAT, *Une tombe inviolée de la XVIII^e dynastie découverte aux environs de Médinet el-Gorab dans le Fayoum* in *Bull. Inst. Fr. Arch. Or.* i, pp. 226-7, pls. i-iii (some of the objects are now in Sinadino Collection in Alexandria).

Various.

Stela, Tuthmosis III before Harsaphes, in Cairo Mus.; texts, LEFEBVRE, *À travers la Moyenne-Égypte* [&c.] in *Ann. Serv.* xii. 94.

SIDMANT (EL-GEBEL)

NECROPOLIS. Dyn. II-III, IX-X, XVIII, XIX.

Extending from Sidmant to Maiyâna.

PETRIE and BRUNTON, *Sedment*, 2 vols. passim; NAVILLE, *Ahnas el Medîneh*, pp. 11-14, pls. vii-ix, xi [A, C]. Plans, PETRIE and BRUNTON, op. cit. pls. lxxxv-xc, xxiv A [top right].

Rock-tombs. Dyn. II-VI.

Plans, id. ib. pl. lxxxi.

MERYRĒ'-HASHETEF , Intimate; Lector. Dyn. VI.

Sepulchral Chamber.

Text of coffin, and inscribed alabaster headrest, id. ib. pls. xii [upper], xi [1, 2], cf. pp. 2-4.

Found in shaft.

Three ebony statuettes of deceased, rough statuette of a woman, and servant-models, id. ib. pls. vii-xi [3-7], cf. pp. 2-3; one of deceased as youth [=pl. viii], in Brit. Mus. 55722, PETRIE, *Discoveries at Herakleopolis* in *Anc. Eg.* (1921), plate opposite p. 65; id. *Seventy Years in Archaeology*, plate opposite p. 242; HALL in ROSS, *The Art of Egypt through the Ages*, p. 110 [1]; see *Guide to the Egyptian Collections* (1930), p. 303; one of deceased with staff [=pl. ix], in Copenhagen, Ny Carlsberg Mus., Æ.I.N. 1560, MOGENSEN, *La Collection égyptienne*, pl. xiii [A 57], cf. p. 15; one of deceased as old man [=pl. x], in Cairo Mus., PETRIE, op. cit. in *Anc. Eg.* (1921), plate opposite p. 66.NENI , First under the King. Dyn. VI.

Hall.

Inscribed ebony statuette, in niche in west wall, and figure of cook, PETRIE and BRUNTON, op. cit. pl. i [19-23], cf. pp. 4, 6, 15.

VARIOUS.

Two wooden statuettes of a royal noble 'Neb-em-suhet', and figures of bread-maker and cook, Dyn. VI, id. ib. pl. xvii [1, 2, 3], cf. p. 4.

Graves. First Intermediate Period.

'A'AUIFI . (2101 of PETRIE and BRUNTON.)

Coffin; text, id. ib. pl. xxiii [lower], cf. p. 10.

WAZET-ḤOTP  or . Dyn. VII or VIII (?). (2106 of PETRIE and BRUNTON.)

Coffins, in Upsala Mus.; texts, id. ib. pl. xxiii [upper], cf. pp. 5, 10-11 [22].

Wooden statuette of deceased, in Copenhagen, Ny Carlsberg Mus., Æ.I.N. 1561, id. ib. pl. xxvi [4], cf. p. 7; MOGENSEN, op. cit. pl. lxii [A 495], cf. p. 66.

Model granary, boats, &c., in Copenhagen, Ny Carlsberg Mus., Æ.I.N. 1569-1572, PETRIE and BRUNTON, op. cit. pl. xx [1-4], cf. p. 7; MOGENSEN, op. cit. pl. lxiii [A 505-8], cf. p. 66.

KHENT-KHETI . (2111 of PETRIE and BRUNTON.)



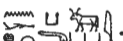

















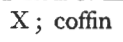













Coffin and inscribed headrest, PETRIE and BRUNTON, op. cit. pls. xviii-xix B, xxi [15], cf. pp. 5, 11-12. Model boat and granary, in Philadelphia, Pennsylvania Univ. Mus., and wooden statuettes of deceased and female offering-bringers, id. ib. pls. xx [5, 6], xxvi [3, 9], cf. p. 7.

NEKHTKAUI . (2127 of PETRIE and BRUNTON.)

Two coffins, in Copenhagen, Ny Carlsberg Mus., Æ.I.N. 1585, 1586, id. ib. pls. xxiv, xxv A, xxv, cf. pp. 5, 12-13; MOGENSEN, op. cit. pl. lxii [A 493-4], cf. p. 66.

Wooden statuette, in Copenhagen, PETRIE and BRUNTON, op. cit. pl. xxvi [1], cf. p. 7.

VARIOUS.

Coffins of Ḥa-Ḥaremsekhtu          , Ḥenty          , Dyn. IX, and In'ankh               , Dyn. X; coffin of last and texts of others, id. ib. pls. xxvii-xxviii, cf. p. 5.





Remains of texts from other inscribed fragments of coffins, id. ib. pl. xxi [20, 21], cf. p. 15.









New Kingdom Tombs.









Plans, id. ib. pls. lxxxii-lxxxiii.

'TAZARTI'. Early Dyn. XVIII.

Coffins, id. ib. pl. xl [1], cf. p. 23.

OFFERING-PLACE OF AMENḤOTP     , Prophet of Harsaphes. Temp. Tuthmosis III.

Stela of deceased and family, offering-table of grandfather Amenmosi  , Prophet, and kneeling statue of Minmosi       , Scribe, all found *in situ*, now in Cairo Mus., id. ib. pls. xlix [1-4], 1 (frontispiece), li [1], cf. pp. 23-4 [40].

NEBENKEMT         , Captain of bowmen; Fanbearer of the royal boat Kha'em-ma'et. Temp. Amenophis III.

Stela, id. ib. pl. lii, cf. p. 24 [43].

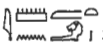
AMENEMHĒT , Divine father of Harsaphes; &c. About temp. Amenophis III.

Stela, id. ib. pl. liii, cf. pp. 24-5 [44].

SETY , Commander-in-chief; Overseer of attendants of the Lord of the Two Lands; Ambassador in all lands. Temp. Ramesses II.

Hall.

Six octagonal pillars, in Cairo, Brussels, Copenhagen, Chicago, and Philadelphia Museums; texts, id. ib. pl. lxix, cf. p. 27 [48]; text of pillar in Brussels, *Musées Royaux du Cinquantenaire*, E. 5780, SPELEERS, *Rec. des Inscr. Ég.* 60 [252]; text of one face of pillar in Copenhagen, Ny Carlsberg Mus., *Æ.I.N.* 1558 [=PETRIE and BRUNTON, 1], MOGENSEN, *La Collection égyptienne*, pl. cx [A 740], cf. p. 102.

Sculptured blocks re-used in another tomb, PETRIE and BRUNTON, op. cit. pl. lxx, cf. p. 27 [48].

P-HONT , Deputy-master of horse; Captain of bowmen. Dyn. XIX.

Stela in Chicago Mus., id. ib. pl. lxxviii, cf. p. 27 [49].

Granite sarcophagus, usurped from Pesiūr , temp. Amenophis II, in Philadelphia, Pennsylvania Univ. Mus.; upper part and texts, id. ib. pls. lv [21], lvi [6], cf. p. 27; upper part, PETRIE, *Discoveries at Herakleopolis in Anc. Eg.* (1921), fig. on p. 67.

RĒ'HOTP , Vizier, and PARĒ'HOTP , Vizier. Temp. Ramesses II.

See PETRIE and BRUNTON, op. cit. pp. 28-31. Plan, id. ib. pl. lxxxiv [upper left].

Hall.

Fragments of columns of Rē-hotp, id. ib. pl. xxii [16-24].

Sepulchral Chamber.

Granite sarcophagus of Rē-hotp, and fragments from sarcophagus of Parē-hotp; texts, id. ib. pl. lxxv, cf. p. 28 [51].

Fragments of canopic jars of Parē-hotp and perhaps of Rē-hotp; texts, id. ib. pl. lxxxiv [left lower].

Offering-table of Rē-hotp, basalt stela of Parē-hotp, and two statue-bases, id. ib. pls. lxxi [4, 6], lxxii [4], lxxiii, lvi [3-5].

Found in or near tomb.

Fragments of reliefs of viziers, one Dḥutmosi , temp. Amenophis II, id. ib. pl. lvi [1-2], cf. p. 29 [53].

Fragments of reliefs and stela, &c., id. ib. pls. lxxii [1, 2, 5, 6], lxxvi [1-3].

Lintel, Rē-hotp kneeling before cartouches of Ramesses II, id. ib. pl. lxxi [2].

Granite shrine of Rē-hotp, id. ib. pl. lxxiv.

Side of alabaster libation-table with offering-list, id. ib. pl. lxxi [1].

Jamb from tomb of Nebḥotep , id. ib. pl. lxxii [3], cf. pp. 29-30.

Stela dedicated by Nebuhōtep , Priest, Lector, id. ib. pl. lxxvi [4], cf. p. 30.

MENNA , Mayor. Dyn. XVIII.

Name, NAVILLE, *Ahnas el Medineh*, p. 12.

FINDS



Stela of Nebiri , Head of attendants, New Kingdom, in Cairo Mus. 34044, GRÉBAUT, *Le Musée Égyptien*, i, pl. xxv; LACAU, *Stèles du Nouvel Empire* (Cat. Caire), pl. xxvi, pp. 76-8; BOREUX, *La stèle-table d'offrandes de Senpou* in *Monuments Piot*, xxv, p. 42, fig. 4.

Stela, Dyn. XIX, found in sand, PETRIE, *Ehnasya*, pl. xli [2], cf. p. 25.

Stela of Merna , Head singer, Saite (?); part of text, LOAT, *Gurob*, pl. xvi [7], cf. p. 8.

Double-stature of priest and priestess, with offering-scenes on back, Dyn. XIX, found in débris in pit, now in Cairo Mus., NAVILLE, *Ahnas el Medineh*, pls. xii [B], i [F], cf. p. 14.

Coffin of Hēnenut , Dyn. XI (usurped); text, id. ib. p. 13.

Coffin of Hētepka , son of Ra'mosi , Dyn. XX or later, id. ib. pl. xi [B] and p. 14.

Wooden statuette of man, Dyn. XVIII or XIX, PETRIE and BRUNTON, *Sedment*, pl. xlix [5], cf. p. 26 [280].

Inscribed cartonnage, Dyn. XIX, and offering-table of a priest, id. ib. pls. lxxviii [54], li [2], cf. p. 28.

IHNĀSYA EL-MEDĪNA  (HERACLEOPOLIS MAGNA)

Plan of site, PETRIE, *Ehnasya*, pl. xliv [top left]; NAVILLE, op. cit. pl. xiii (inaccurate).

TEMPLE OF HARSAPHES. Dyn. XII, rebuilt Dyn. XVIII and by Ramesses II, re-used Dyn. XXIII-XXX and Roman Period.

See PETRIE, *Excavations at Ehnasya in Archaeological Report* (1903-4), pp. 12-14; id. *Ehnasya*, pp. 3-17. Plans, id. ib. pls. iv-vii, ix. Views, id. ib. pls. ii, iii, x [1-3], NAVILLE, op. cit. frontispiece.

Court.

Granite triad of Ramesses II between Ptaḥ and Harsaphes, found lying in front of court on west, now in Cairo Mus., see PETRIE, *Ehnasya*, pp. 9-10.

Smaller similar triad, found on east side, see id. ib. p. 10.

Portico. Dyn. XVIII, rebuilt by Ramesses II.

Reconstruction of façade, and plan showing positions of blocks, id. ib. pl. viii, cf. pp. 8, 10-11, 12-15.

Sandstone half-wall, and granite architraves, id. ib. pls. xvii, xviii, cf. pp. 10-11, 21.

Red granite palm-columns, Dyn. XII, re-used Ramesses II and Merneptah, one in Brit. Mus. 1123 [cf. *Guide, Sculpture* (1909), pp. 164-5 (599)], NAVILLE, op. cit. pls. v, vi, cf. pp. 9-10; scenes on shafts, Ramesses before Harsaphes, Horus, and Osiris, and cartouches of Merneptah, id. ib. pl. ii; one capital, PETRIE, op. cit. pl. x [4] cf. p. 7. White quartzite inscribed drums, id. ib. pl. xvi [middle], cf. p. 15.

Statue, usurped by Ramesses II probably from Sesostris II or III, found *in situ* in north-east corner, now in Philadelphia, Pennsylvania Univ. Mus., NAVILLE, op. cit. pl. x [A, B], cf. p. 11.

Fellow statue (broken), found in north-west corner, now in Cairo Mus.; base, id. ib. pl. i [C]; PETRIE, op. cit. pl. xix, cf. pp. 10, 15, 21-2.

Entrance to Hypostyle.

Doorway. Jambs, and texts of thicknesses, NAVILLE, op. cit. pl. i [A, B], and p. 9, cf. p. 10; jambs, PETRIE, op. cit. pl. xvi [bottom], cf. p. 21.

Hypostyle.

Gold statuette of ram-headed Harsaphes, with cartouche of Neferkarê Petubastis, Dyn. XXIII, found in pavement, now in London, Univ. Coll., PETRIE, *op. cit.* frontispiece, and p. 18; *id. Excavations at Ehnasya in Man* (1904), pl. H, cf. pp. 113-14 [77]; see GAUTHIER, *Le Livre des Rois*, iii. 400 [3].

Re-used blocks.

Two blocks from a tomb with name of Mert-Hathor , Dyn. V, re-used in foundations of Hypostyle, PETRIE, *Ehnasya*, pl. xii [upper], cf. p. 20.

Block with relief of King, Dyn. VI, used as foundation in front of façade, *id. ib.* pl. xi [top], cf. p. 19.

Granite lintel and jamb of Sesostris II, re-used in basement of Ramesside façade, *id. ib.* pl. xiii [upper and bottom left], cf. pp. 7, 20; part of jamb, NAVILLE, *op. cit.* pl. i [E].

Block of Sesostris II, re-used in façade, *id. ib.* pl. i [D], cf. p. 10.

Block of Sesostris III, re-used in back wall, PETRIE, *op. cit.* pl. xi [middle], cf. p. 20.

Fragments, Dyn. XII, including names of Sesostris III, Amenemhêt III, and Princess Shedet-tefsi , *id. ib.* pls. xii [bottom left], xiii [lower, middle and right], xiv, cf. p. 20.



Block from wall, Dyn. XII, in Brussels, Musées Royaux du Cinquantenaire, E. 594, *id. ib.* pl. xv [upper], cf. p. 20; texts, SPELEERS, *Rec. des Inscr. Ég.* 15 [67].

Blocks from *heb-sed* festival scene, Ramesses II, some re-used in back wall, PETRIE, *op. cit.* pls. xi [bottom left], xx, xxi [upper], cf. pp. 20, 22.

Fragments, including one with name of Princess Bent'anta, daughter of Ramesses II, *id. ib.* pls. xv [lower], xxi [lower], xxii, xxiii, xxv, xxvi, cf. p. 22.

Found in Temple.

Fragment of statue of Ramesses II kneeling with small altar (?), in Cairo Mus. 580, BORCHARDT, *Statuen und Statuetten* (Cat. Caire), ii, pl. 99, p. 131.

Stelae of Setemhab , Commander of troops, Governor of the fortress of the Shardana, &c., Dyn. XIX, of Pazesef , Shardana soldier of the fortress of Userma'et're', Dyn. XXII, and of Innakht , PETRIE, *op. cit.* pl. xxvii [1-3] and p. 22.

Granite torso of Ramesside King, found in Portico, NAVILLE, *op. cit.* pl. x [C], cf. p. 11.

Fragment of leg of statue of Sementu-tefnakht  [temp. Psammetikhos I], in Brussels, Musées Royaux du Cinquantenaire, E. 1874, PETRIE, *op. cit.* pl. xxvii [4], cf. pp. 22-3; text, SPELEERS, *op. cit.* 83 [314]; see DARESSY, *Samtaui-tafnekht* in *Ann. Serv.* xviii. 32. (Cf. *infra* p. 121, and *supra* pp. 46, 71.)

Fragment from basalt naos of Achoris, found in débris outside temenos east of Court, PETRIE, *op. cit.* pls. xi [bottom right], xxviii [upper left], cf. pp. 20, 23.

Fragment of granite naos of Nektanebos II, see *id. ib.* p. 17.

Boundary-stone with name of Harsaphes, found outside front of Court, *id. ib.* pl. xii [bottom right], cf. p. 20.

KÔM EL-'AQÂRIB, south of Temple of Harsaphes.**DESTROYED TEMPLE. Ramesses II.**

Plan, DARESSY, *Deux grandes statues de Ramsès II d'Héracléopolis* in *Ann. Serv.* xvii, p. 34, fig. 1.

Re-used blocks with cartouches of Queen Sebekneferurê (here written ) and of Sesostris III; texts, *id. ib.* pp. 34, 35.

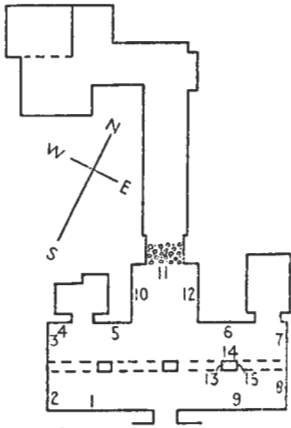

DISHÂSHA. Inti. From PETRIE, *Deshasheh*, pl. iii [upper].

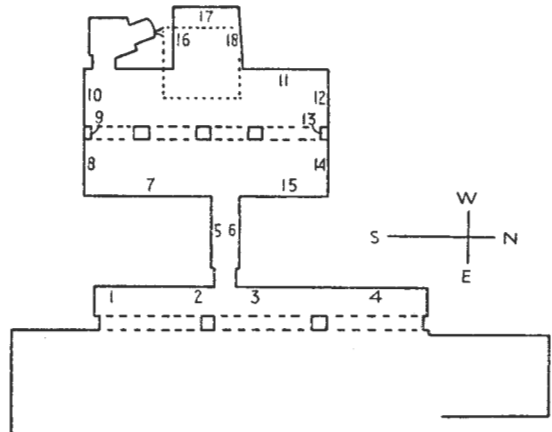

DISHÂSHA. Iteti. From PETRIE, *Deshasheh*, pl. iii [lower].

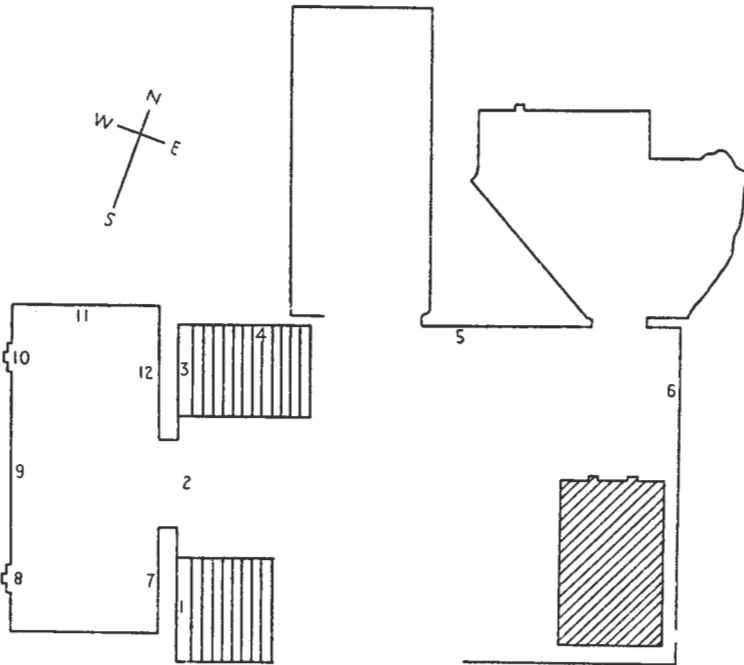

EL-KÔM EL-AḤMAR SAWÂRIS. Pepy'-ankh. After BRODRICK and MORTON in *P.S.B.A.* xxi, second plate after p. 32.

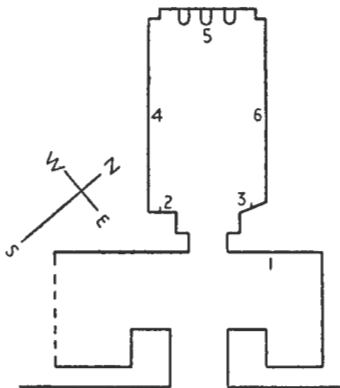

EL-SIRÎRÎYA. Rock-chapel. From *L. D. Text*, ii, p. 47.

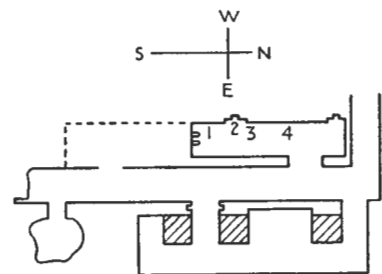

GEBEL EL-TEIR. Iymery. From KAMAL in *Ann. Serv.* iv, p. 86, fig. 2.

Two seated colossi of Ramesses II, re-used by Merneptah, probably usurped from Sesostris III, with small statues of Princesses Bent'anta and Merytamûn and two unnamed princesses, in Cairo Mus., EVERS, *Staat aus dem Stein*, ii, pls. xv [69, 70], xvi [71]; one princess, id. ib. pl. xvi [72]; texts, DARESSY, op. cit. in *Ann. Serv.* xvii. 36-8.

MISCELLANEOUS

(From Ihnâsya el-Medîna, but exact provenance unknown.)

Red granite block of Amenophis IV, found in Roman house west of Temple, PETRIE, op. cit. pl. xvi [top], cf. pp. 20-1.

Headless squatting statue of Hêtep $\frac{\text{𓆎}}{\text{𓆏}}$, Mayor of Heracleopolis Magna, Dyn. XVIII, in Cairo Mus. 563, BORCHARDT, op. cit., ii, pl. 95, pp. 111-13; texts, MARIETTE, *Mon. Div.* pl. 21 [a].

Fragments of cubical granite stand of Sesonchis I, inscribed with endowment of the temple at the request of his son Nemareth $\text{𓆎} \text{𓆏} \text{𓆐}$, in Cairo Mus.; text, KAMAL, *Un Monument nouveau de Sheshonq I^{er}* in *Rec. de Trav.* xxxi. 33-6; corrections of text, DARESSY, *Notes sur les XXII^e, XXIII^e et XXIV^e dynasties* in *Rec. de Trav.* xxxv. 133-5 [v].

Stela (text destroyed) with cartouches of Petubastis I, Dyn. XXIII; text, DARESSY, *Fragments héracléopolitains* in *Ann. Serv.* xxi. 140.

Stelae of Arut $\text{𓆎} \text{𓆏} \text{𓆐}$, daughter of Queen Tshenêsi $\text{𓆎} \text{𓆏} \text{𓆐}$, year 10 of Neferkarê' Petubastis, Dyn. XXIII, found in *sebakh*, in Cairo Mus., DARESSY, *Stèle du roi Pefnifdubast* in *Ann. Serv.* xvii. 43.

Stela of daughter of Queen Tshenêsi, year 10 of Neferkarê' Petubastis; remains of text, DARESSY, op. cit. in *Ann. Serv.* xxi. 138-9.

Base of black granite kneeling statue of Semtu-tefnakht $\text{𓆎} \text{𓆏} \text{𓆐}$, Overseer of the south, holding naos, [temp. Psammetikhos I], in Cairo Mus.; texts, DARESSY, *Samtauitafnekht* in *Ann. Serv.* xviii. 29. (Cf. supra p. 119.)

Kneeling statuette of 'Ankh-theker $\text{𓆎} \text{𓆏} \text{𓆐}$, holding figure of Osiris, Saite; text, id. op. cit. in *Ann. Serv.* xxi. 143.

Headless statue of Semtu-tefnakht $\text{𓆎} \text{𓆏} \text{𓆐}$, Governor in Upper Egypt, Overseer of prophets in Heracleopolis Magna, &c., holding naos of Osiris, about Dyn. XXX; text, id. ib. 141-3.

Graeco-Roman blocks, re-used in Roman house, PETRIE, op. cit. pl. xxviii [right], cf. p. 23.

DISHÂSHA

CEMETERY

PETRIE, *Deshasheh*, passim. Plans of site, id. ib. pls. i, ii.

INTI $\text{𓆎} \text{𓆏} \text{𓆐}$, Overseer of commissions; Overseer of royal monuments; Ruler of the Residence. Old Kingdom. (Rock-tomb.)

See id. ib. pp. 4-8, and GRIFFITH in id. ib. pp. 42-4. Plan, PETRIE, op. cit. pl. iii [upper].

Hall.

(1) Remains of three registers, painters and sculptors, huntsman with dogs, and scribe, craftsmen, &c., before deceased and wife, id. ib. pl. xiii.

(2)-(3) Four registers, men dancing, musicians, and butchers, before deceased and

wife, id. ib. pl. xii; overthrowing ox, from fourth register, id. *Egypt in Africa in Anc. Eg.* (1914), p. 124 [lower]; WRESZINSKI, *Bericht über die photographische Expedition* [&c.], pl. 2.

(4) Four registers, men bringing oryx, ibex, addax, and bull, PETRIE, *Deshasheh*, pl. xi.

(5) Deceased and wife with small daughter, id. ib. pl. x.

(6) Deceased in boat, boatmen on shore, with dwarf, men leading bull and musicians below; boat and boatmen, id. ib. pl. vi.

(7)-(8) Four registers, catching fowl in draw-net, gathering papyrus, tending cows, and fishing with draw-net from boat, id. ib. pl. v.

(9) Capture of Syrian fortress, id. ib. pl. iv; omitting text, id. *Seventy Years in Archaeology*, plate opposite p. 166; WRESZINSKI, *Atlas*, ii. 4; MEYER, *Darstellungen der Fremdvoölker*, 37-44.

Recess.

(10) Four registers (middle ones destroyed), children and offering-bringers before deceased and wife, PETRIE, *Deshasheh*, pl. ix.

(11) Deceased and wife before offerings and offering-list, id. ib. pl. viii.

(12) Deceased and wife with text recording making of tomb, id. ib. pl. vii; text, SETHE, *Urk.* i. 69-71 (47).

Pillar.

(13) Two registers, figure of deceased, PETRIE, op. cit. pl. xiv [left lower, right lower].

(14) Two registers, deceased, and wife, id. ib. pl. xiv [middle].

(15) Two registers, figure of deceased, id. ib. pl. xiv [left upper, right upper].

ITETI  , good name SHEDU , First under the King; Over-seer of Land; &c. Temp. Teti or later. (Rock-tomb.)

See PETRIE, op. cit. pp. 9-11, and GRIFFITH in id. ib. pp. 44-6. Plan, PETRIE, op. cit. pl. iii [lower].

Façade (sanded up).

(1)-(2) Deceased harpooning fish, pyramid with temple, and offering-bringers below, id. ib. pl. xxiv.

(3?)-(4?) Remains of funeral procession; two boats, and cooking scene at base, id. ib. pl. xxv [upper].

Entrance.

(5) and (6) Thicknesses (sanded up). Remains of texts, id. ib. pl. xxv [lower]; SETHE, *Urk.* i. 89-90 (9) A, B.

Hall.

(7) Remains of three registers, granaries, harvest, and butchers, PETRIE, op. cit. pl. xxiii.

(8) Deceased and family fishing in marshes, id. ib. pl. xxii.

(9) Pilaster. Remains of titles, id. ib. pl. xix [top middle].

(10) Three registers, carpenters and leather-workers before deceased with daughter, id. ib. pl. xxi.

(11) Four registers, scribes with offering-tables (effaced), tending, bringing, and overthrowing cattle before deceased (partly destroyed), id. ib. pl. xviii; fourth register, overthrowing bull, WRESZINSKI, *Bericht über die photographische Expedition* [&c.], pl. 3.

(12) Offerings, and three registers offering-bringers before deceased and sister, PETRIE, op. cit. pl. xvii.

- (13) Pilaster. Remains of titles, id. ib. pl. xix [top left].
 (14) Deceased watches vineyard and wine-making, id. ib. pl. xvi.
 (15) Remains of four registers (top one entirely destroyed), bringing fowl from draw-net, goats browsing, and cattle crossing inundation before deceased (destroyed), id. ib. pl. xv.

Recess.

- (16) Deceased before altar, and offering-list, id. ib. pl. xx.
 (17) False door, id. ib. pl. xix [bottom].
 (18) Fragment of text, id. ib. pl. xix [right] (incorrectly called south), cf. p. 10.

NENKHEFTKA , Overseer of commissions; Ruler of the Southern City of the Goat(?); Royal priest. Late Dyn. V or VI. (Mastaba.)

Serdab.

Remains of statues of deceased, wife, and son Nenkheftek, PETRIE, *Deshasheh*, pls. xxx-xxxii, xxxiii [lower], frontispiece, and pp. 12-15, and GRIFFITH in id. ib. p. 47; seated statue of deceased with small son [PETRIE, xxxii (7, 8)], in Cairo Mus. 649, BORCHARDT, *Statuen und Statuetten* (Cat. Caire), ii, pl. 120, pp. 195-6; standing statue of deceased [PETRIE, xxx (left)], in Brit. Mus. 1239, BUDGE, *Egyptian Sculptures in the British Museum*, pl. iii (called Dahshûr); *Guide to the Egyptian Collections* (1909), fig. on p. 109; (1930), p. 166, fig. 89; WEIGALL, *Anc. Eg. Works of Art*, 48 [left]; HALL in ROSS, *The Art of Egypt through the Ages*, p. 110 [2]; headless squatting statue of Nenkheftek [PETRIE, p. 13 (c), pl. xxxiii (30)], in Brit. Mus. 29562, see *A Guide to the Third and Fourth Egyptian Rooms* (1904), p. 91 [160]; *Guide to the Fourth, Fifth and Sixth Egyptian Rooms* (1922), p. 120 [11].

NENKHEFTEK , Overseer of scribes of land; *śšm-t* of Heracleopolis Magna; &c.; son of Nenkheftka. Late Dyn. V or VI.

Coffin, in Cairo Mus. 28122; texts, PETRIE, op. cit. pl. xxix, cf. p. 15 [23], and GRIFFITH in id. ib. p. 47; LACAU, *Sarcophages antérieurs au Nouvel Empire* (Cat. Caire), ii. 135.

MERI , King's noblewoman; Prophetess of Hathor. Old Kingdom.

Coffin and inscribed headrest, PETRIE, op. cit. pls. xxvii [upper], xxviii, xxxiv [4], cf. p. 20, and GRIFFITH in id. ib. pp. 46-7.

Painted board with scenes of servants preparing offerings, and boats, PETRIE, op. cit. pl. xxvii [lower].

FINDS

Painted statue of man (uninscribed), Dyn. V, in Cairo Mus. 651, BORCHARDT, op. cit. ii, pl. 120, cf. p. 196 (from Petrie excavations).

KAFR ABÛ SHAHBA

Stela of Achoris, built into bridge, probably from temple at Ihnâsya el-Medîna, in Cairo Mus.; fragment of text, KAMAL, *Stèle d'Acoris, deuxième roi de la XXIX^e dynastie* in *Ann. Serv.* iii. 243.

EL-GAMHÛD

West of El-Fashn.

CEMETERY. Ptolemaic.

Plan, KAMAL, *Fouilles à Gamhoud* in *Ann. Serv.* ix. 10.

Coffins, in Cairo Mus., Budapest, Vienna, and Cracow; texts, id. ib. pp. 14-25 and pl. i.



Demotic stelae of Petisis and Nechthyris, id. ib. pl. ii, cf. p. 28.

EL-BAHNASA (OXYRHYNCHUS)

CITY¹ AND CEMETERIES. Ptolemaic and Roman.

See PETRIE, *Tombs of the Courtiers and Oxyrhynchos*, pp. 12-18, pls. xxxv-xxxvi, xxxvii [3-8], xxxviii, xlv-xlvii [1-7]. Plan of site, and tomb-plans, id. ib. pls. xxxix-xliv [upper]. View of standing column, Roman, DENON, *Voyage* (1802), pl. 31 [2].

EAST BANK

EL-ḤĪBA (ANKYRONPOLIS?)  (or  Teuzoi)

Map of site, WILKINSON MSS.* xvii. J. 2, cf. ix. 115-16. General account, including discoveries of the papyri of Dyn. XXI and XXVI, see GRIFFITH, *Cat. Demotic Papyri in the John Rylands Library, Manchester*, iii, pp. 37-42.

TEMPLE. Sesonchis I and Osorkon I.

Description and views, RANKE, *Koptische Friedhöfe bei Karāra*, pls. 22 [1, 2], 23, 24 [1, 2], pp. 58-68; description and remains of texts, KAMAL, *Description générale des ruines de Hibé* [&c.] in *Ann. Serv.* ii. 85-9; DARESSY, *Le Temple de Hibéh* in *Ann. Serv.* ii. 154-6; description, BONOMI MSS.* Diary, June 20, 1831; cartouches, WILKINSON MSS.* ix. 114. Plan and sections, RANKE, op. cit. plans 9, 10; plan, KAMAL, op. cit. p. 85, fig. 3. Foundation deposit, RANKE, op. cit. pl. 25 [3].

First Pillared Hall.

Wall. Fragment from scene of King smiting enemies, id. ib. pl. 20.

Pillars. West row, second pillar from north. South face, King with two pectorals and necklace before Horus, id. ib. pls. 19 [1], 21 [4], cf. p. 65. East face, King with incense before Atum, id. ib. pl. 21 [3]. Fragment from a pillar; head of King, id. ib. pl. 21 [1].

Second Pillared Hall.

Top part of scene of King with incense before Isis (?) from one of the central pillars, id. ib. pl. 19 [2].

TOWN-SITE. Dyn. XXI.

Bricks of Pinezem I, and Menkheperre' with Queen Esenkhebi , in Berlin Mus. 1566, 1616, L. D. iii. 251 h, i, and *Text*, ii, pp. 45-6; PRISSE, *Mon.* xxiii [6, 7, 11, 12]; id. *Lettre à M. Champollion Figeac* in *Rev. Arch.* i (1844), 725; WILKINSON, *Modern Egypt and Thebes*, ii. 22; SHARPE, *Eg. Inscr.* 2 Ser. 56 [11-16]; NESTOR L'HÔTE MSS.* 20396, 208; of Menkheperre', PRISSE, *L'Art Égyptien, Texte*, p. 179; SPIEGELBERG, *Briefe der 21. Dynastie aus El-Hibe* in *Ä.Z.* liii. 4; see *Ausführ. Verzeichnis* (1899), p. 450.

Lintel of door of Tuthmosis I, in Cairo Mus., MASPERO in GRÉBAUT, *Le Musée Égyptien*, i, pl. xxix A, cf. p. 26.

¹ For the Greek papyri, &c., from the rubbish-mounds of the city, see GRENFELL and HUNT, *Oxyrhynchus Papyri*, seventeen volumes already published.

CEMETERY.

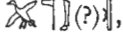
Lintel of door from tomb of Pwehemnūti  (?), Head of the stable of the Lord of the Two Lands, temp. Ramesses III, in Cairo Mus.; texts, DARESSY, *Bas-relief d'un écuyer de Ramsès III* in *Ann. Serv.* xx. 4-6; see MASPERO, *Guide* (1914), p. 180.

Coffin of Khenstefnakhti , Saite, in Brussels, Musées Royaux du Cinquantenaire, E. 586; text, SPELEERS, *Rec. des Inscr. Ég.* 89-91 [337].

Coffin of Pedehor , Ptolemaic, DARESSY, *Un cercueil de Hibeh* in *Ann. Serv.* iv. 116-19.

Coffins of Mutardais and Zeubastef'onkh, Late Period, in Hildesheim Mus. 1953, 1954, IPPEL and ROEDER, *Die Denkmäler des Pelizaeus-Museums zu Hildesheim* (1921), p. 99, Abb. 35.

EL-KÔM EL-AḤMAR SAWÂRIS 

South of Shârûna.

CEMETERY

ROCK-TOMB OF PEPY-'ANKH  ♀ , good name KHUI ,

Lector; Chief of *sm*-priests; Director of the Kilt; &c. Dyn. VI.

(See plan, supra p. 120.)

BRODRICK and MORTON, *The Tomb of Pepi Ankh (Khua) near Sharona* in *P.S.B.A.* xxi. 26-33, with plans of walls; texts, SMOLENSKI, *Le tombeau d'un prince de la VI^e dynastie à Charouna* in *Ann. Serv.* viii. 150-2; various titles, NESTOR L'HÔTE MSS.* 20413, 2nd carton, N, 3rd carton, c', G', J' (squeezes). Plans, BRODRICK and MORTON, op. cit. plans i, ii; omitting sepulchral chambers, SMOLENSKI, op. cit. p. 149, fig. 1 (inaccurate); NESTOR L'HÔTE MSS.* 20396, 211. View, CAPART, *La Tombe aux guêpes* in *Chronique d'Égypte*, July 1927, fig. on p. 117.

Court.

(1) Man offering to deceased and wife, NESTOR L'HÔTE MSS.* 20404, 11, 20409, 4th carton, A (squeeze); upper part of deceased with name, id. *Lettres écrites d'Égypte*, p. 32; names of deceased and wife, BRODRICK and MORTON, op. cit. 30 [B, D, H]; SMOLENSKI, op. cit. 150 [middle].

(2) Remains of text above door, BRODRICK and MORTON, op. cit. 30 [K]; SMOLENSKI, op. cit. 150 [bottom].

(3) Deceased with two men, and offering-list, NESTOR L'HÔTE MSS.* 20409, 4th carton, B, 20413, 3rd carton, F' (squeezes); texts, BRODRICK and MORTON, op. cit. 30 [P-V]; SMOLENSKI, op. cit. 151 [upper].

(4) and (5) Deceased and family harpooning fish and fowling in marshes; harpooning scene, NESTOR L'HÔTE MSS.* 20396, 211 verso, 20409, 4th carton, C, 20413, 3rd carton, H' (squeezes); texts, WRESZINSKI, *Bericht über die photographische Expedition* [&c.], p. 27; incomplete, SMOLENSKI, op. cit. 150 [top]; remains of titles, BRODRICK and MORTON, op. cit. 29 [H. H, I]; text above deceased fowling, NESTOR L'HÔTE MSS.* 20409, 4th carton, G (squeeze).

(6?) Remains of boating scene; woman and child in dahabiya, BRODRICK and MORTON, op. cit. 27.

Hall.

(7) Vases, table of offerings, men bringing fowl and animals, butchers; texts of offering-bringers, id. ib. 31 [lower].

(8) False door of wife Merut , SMOLENSKI, op. cit. 151 [lower]; texts, BRODRICK and MORTON, op. cit. 32 [A-G].

(9) Top register, vases, two priests offering libation, and offering-list, second to fourth registers, foreigners (?) with offerings before deceased (destroyed); omitting one register of offering-bringers and figure of deceased, NESTOR L'HÔTE MSS.* 20409, 4th carton, D, E, H (squeezes); see sketch-plan, BRODRICK and MORTON, op. cit. plan viii.

(10) False door of deceased, SMOLENSKI, op. cit. 152; texts, BRODRICK and MORTON, op. cit. 32-3 [H-S].

(11) Deceased before offerings, and offering-bringers below, see sketch, id. ib. plan vi; texts of offering-bringers, id. ib. 31 [upper]; SMOLENSKI, op. cit. 152 [bottom]; text and offering-bringers (probably from this scene), NESTOR L'HÔTE MSS.* 20409, 4th carton, F (squeeze).

(12?) Deceased with six columns text above, two registers men with cattle, id. ib. 20409, 4th carton, J (squeeze).

ROCK-TOMB OF BEBI , Overseer of a department in the garden of the Great House. Dyn. VI.

Stela, found *in situ*, GRENFELL and HUNT, *Excavations at Hibeh, Cynopolis and Oxyrhynchus in Archaeological Report* (1902-3), frontispiece [lower], cf. p. 4.

ROCK-TOMB OF PEDEAMÛN , Wizard. Saite.

Doorway. Double scene, deceased before Osiris; texts, DARESSY, *Notes et Remarques in Rec. de Trav.* xvi. 44-5 [xcviii]; BRODRICK and MORTON, op. cit. plate after p. 32, cf. 33.

TOMB OF PAMURË' , Graeco-Roman.

Coffin; text, SMOLENSKI, *Le nom géographique de  ou * in *Ann. Serv.* ix. 94.

TEMPLE. Ptolemy I Soter I. (Destroyed.)

Blocks found built into ruined house, probably on ancient site; texts, SMOLENSKI, *Les Vestiges d'un temple ptolémaïque à Kom el-Ahmar près de Charouna in Ann. Serv.* ix. 3-6; remains of cartouches of Ptolemy I on a cornice, DARESSY, op. cit. in *Rec. de Trav.* xvi. 44 [xcviii].

Fragments with cartouche of Ptolemy II Philadelphus, re-used in village of Shârûna, SMOLENSKI, *Nouveaux vestiges du temple de Kom-el-Ahmar près de Charouna in Ann. Serv.* x. 26-7.

EL-SHEIKH FADL

Granite statue of a King, Roman, found in village of Nazlet Sala, in Cairo Mus. 703, BORCHARDT, *Statuen und Statuetten* (Cat. Caire), iii, pl. 130, cf. pp. 44-5.

EL-SIRÎRÎYA

ROCK-CHAPEL OF HATHOR OF 'AKHWI. Merneptah. (See plan, supra p. 120.)

Description, HAY*, 29857, 32; NESTOR L'HÔTE MSS.* 20396, 216; WILKINSON, *Modern Egypt and Thebes*, ii. 32-3; BONOMI MSS.* Diary, June 21, 1831, (probably). Plan, L. D. i. 57 [bottom right], iii. 198 a, and *Text*, ii, p. 47; WILKINSON MSS.* vi. 139 [bottom right], cf. 173; NESTOR L'HÔTE MSS.* 20396, 58.

Forecourt.

(1) Later text of Meḥaḥiy , First prophet of Amūn and of Sobk, L. D. *Text*, ii, p. 47 [bottom]; WILKINSON MSS.* xii. 148 [lower left]; NESTOR L'HÔTE MSS.* 20396, 58 verso.

Hall.

Sketch-plan with frieze-texts and base, BURTON MSS.* 25636, 6 [lower]-7.

(2) and (3) King on one side of door and Osiris on the other side, L. D. iii. 198 b, d, cf. *Text*, ii, p. 48 [upper]; NESTOR L'HÔTE MSS.* 20396, 223 [right, left].

(4) Three scenes, King and Queen (destroyed) before god and goddess, before Ḥaṭḥor, and before Amen-rē, with cartouches of Sethos II below, L. D. iii. 198 c, cf. *Text*, ii, p. 48 [lower]; NESTOR L'HÔTE MSS.* 20396, 222.

(5) Three statues, Ḥaṭḥor with King and Queen (?), L. D. i. 57 [bottom right]; NESTOR L'HÔTE MSS.* 20396, 223 [middle]; BURTON MSS.* 25636, 8 [upper]; see WILKINSON MSS.* vi. 139 [bottom right].

(6) King offers bread to Anubis, sistra to Ḥaṭḥor, and *heb-sed* to Ptaḥ, L. D. iii. 198 e; part, WILKINSON MSS.* xii. 8 [lower]-9 [lower], 10 [left], 148 [lower right], xvii. h. 31 [left]; cat beside Ḥaṭḥor-emblem on altar in front of Ḥaṭḥor, id. ib. h. 31 [middle]; King before Ptaḥ, id. ib. vi. 139 [lower]; texts of divinities, HAY*, 29847, 56 [bottom right]; of Ptaḥ, Anubis, and Ḥaṭḥor, HAY*, 29857, 31 verso; texts to scene before Ptaḥ, BURTON MSS.* 25636, 6 [upper]; text below scenes, SHARPE, *Eg. Inscr.* 2 Ser. 60, l. 8; WILKINSON MSS.* vi. 139 [upper], xii. 149 [upper], xvii. h. 31 [right].

ROCK-STELA, near entrance to Rock-chapel.

Ramesses III followed by Ḥaṭḥor receives *heb-sed* from Sobk (Thoth according to NESTOR L'HÔTE, but head is destroyed), L. D. iii. 207 a, cf. *Text*, ii, p. 49 [middle]; WILKINSON MSS.* xii. 8 [upper]-9 [upper]; NESTOR L'HÔTE MSS.* 20396, 220; title of Sobk, HAY*, 29847, 56 [middle right], 29857, 32 [bottom right]; see WILKINSON, *Modern Egypt and Thebes*, ii. 33.

GEBEL EL-TEIR ROCK-TOMB OF IYMERY , Royal ruler; Scribe. Old Kingdom.

(See plan, supra p. 120.)

Plan, KAMAL, *Fouilles à Gebel-el-Teyr* in *Ann. Serv.* iv, p. 86, fig. 2.

Hall.

(1) Deceased with son, and four registers, men, women, and offering-bringers below; texts, id. ib. 86-7.

(2) False door; texts, id. ib. 87-8.

(3) Jamb of false door, five women; names, id. ib. 88 [bottom].

(4) Deceased before offerings, and offering-list and three women below; texts, id. ib. 89.

ṬIHNA (TĒNIS OR ACŌRIS) 

See NESTOR L'HÔTE MSS.* 20396, 224-7. Views, HAY*, 29847, 28, 29 (called Ṭaḥṭa). Map of site, *Descr. de l'Égypte, Ant.* iv, pl. 67 [14], cf. *Texte*, iv, pp. 372-7; WILKINSON MSS.* xvii. J. 9 dentro [left]; KAMAL, *Fouilles à Tehneh* in *Ann. Serv.* iv, p. 232, fig. 1; BISSING and KEES, *Tine* in *Sitzungsb. d. Bayer. Akad. d. Wiss. (Phil. Hist. Kl.)*, 1928, p. 7.

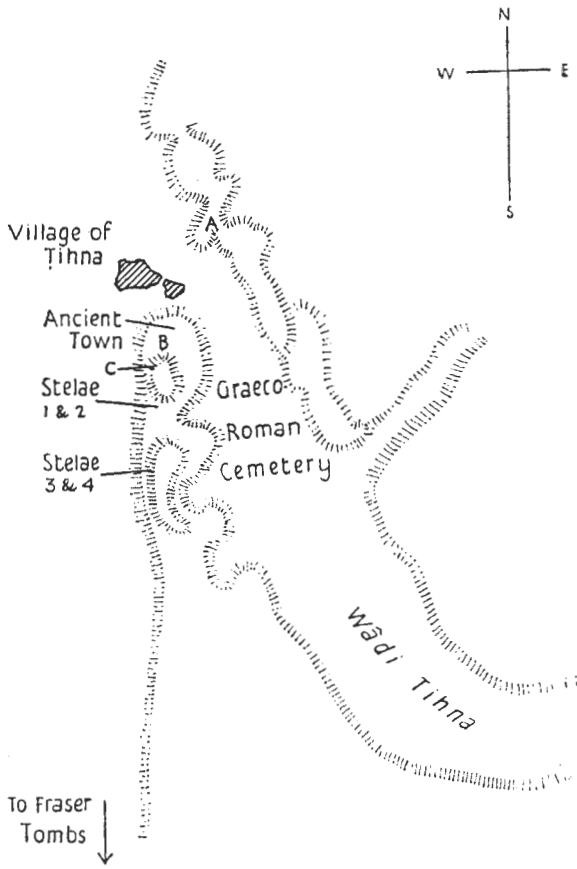

TIHNA. KEY-PLAN.
After WILKINSON MSS.* xvii, J. 9 dentro [left].

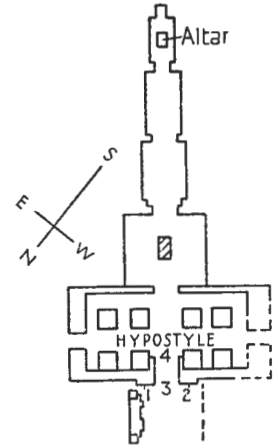

TIHNA. B. Temple of Nero. From LEFEBVRE and BARRY in *Ann. Serv.* vi. 143.

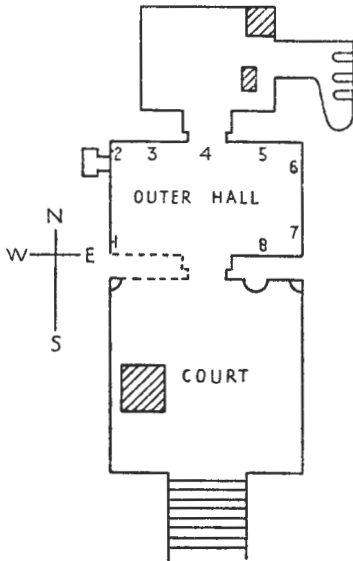

TIHNA. A. Roman Temple.

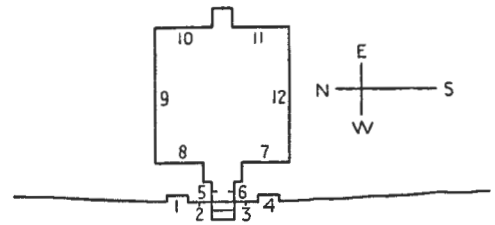

TIHNA. C. Graeco-Roman Chapel. After *L. D. Text*, ii, p. 50.

TEMPLES

A. ROMAN TEMPLE, north of ancient town.

See L. D. *Text*, ii, p. 54; HAY*, 29857, 33-4. Plan, *Descr. de l'Égypte, Ant.* iv, pl. 67 [16]; L. D. *Text*, ii, p. 53; rough plan, NESTOR L'HÔTE MSS.* 20396, 235 [bottom]; section, HAY*, 29857, 34. View of exterior, NESTOR L'HÔTE MSS.* 20396, 235 [middle].

Outer Hall.

(1)-(2) Lower part, Khons, Hāthor, Sekhmet, and Nephthys, temple-door (above entrance to niche), and Hāthor, NESTOR L'HÔTE MSS.* 20396, 234 [top]; temple-door, BURTON MSS.* 25636, 4 [middle left].

(3)-(4) Lower part, Thoth, Sobk, and Horus with spear, and boat above door, NESTOR L'HÔTE MSS.* 20396, 234 [middle left].

(5) Lower part, Amūn, a god, god with spear, and Shu, id. ib. 234 [middle right].

(6)-(7) Lower register, five gods (four destroyed), id. ib. 234 [bottom].

(8) Lower part, Hāthor and four ram-headed gods, id. ib. 235 [top].

B. TEMPLE OF NERO.

Plan, LEFEBVRE and BARRY, *Rapport sur les fouilles exécutées à Tehneh en 1903-4* in *Ann. Serv.* vi, p. 143, fig. 1. Views, WRESZINSKI, *Bericht über die photographische Expedition* [&c.], pls. 8-10, cf. 7 [B]; LESQUIER, *Fouilles à Tehneh (1908)* in *Bull. Inst. Fr. Arch. Or.* viii, pl. i, cf. pp. 113-33, pls. ii-xi.

Entrance to Hypostyle.

(1) Jamb, King offering, and northern Nile below; texts with cartouche of Nero and 'Pharaoh', LEFEBVRE and BARRY, op. cit. 145.

(2) Jamb, destroyed scene and southern Nile below; remains of texts, id. ib. 146.

(3) Lintel (lying on ground), King followed by priest (?) before Sobk and hawk-headed Sobk on shrine; texts, id. ib. 147 [upper].

Hypostyle.

(4) Lintel (lying outside), goddess seated, and King before goddess and Thoth; texts, id. ib. 147-8.

Re-used blocks built into walls; remains of cartouches of Ramesses II, id. ib. 144.

C. GRAECO-ROMAN CHAPEL.

Plan, *Descr. de l'Égypte, Ant.* iv, pl. 67 [15]; L. D. *Text*, ii, p. 50; KAMAL, *Fouilles à Tehneh* in *Ann. Serv.* iv, p. 233, fig. 2; HAY*, 29813, 19 [middle left]; BURTON MSS.* 25634, 38 [upper left]. Brief mention, BONOMI MSS.* *Diary*, Jan. 6, 1825.

Entrance.

(1)-(4) Façade, *Descr. de l'Égypte, Ant.* iv, pl. 67 [18]; HAY*, 29813, 19 [left and right], 20, 29847, 5 verso [left]; NESTOR L'HÔTE MSS.* 20396, 229 [left]; see sketch, BURTON MSS.* 25636, 5.

(1) Figure in Graeco-Roman costume, KAMAL, op. cit. p. 235, fig. 4; BURTON MSS.* 25634, 38 [lower left].

(2) and (3) Jambs, three registers seated divinities on each; five names, L. D. *Text*, ii, p. 50; three names, KAMAL, op. cit. 234-5.

(4) Serpent with text, L. D. *Text*, ii, p. 51 [top]; KAMAL, op. cit. p. 233, fig. 3; omitting text, BURTON MSS.* 25634, 38 [lower right].

(5) and (6) Thicknesses; texts, *L. D. Text*, ii, p. 51 a; KAMAL, op. cit. 234; NESTOR L'HÔTE MSS.* 20396, 229 [right].

Hall.

See *L. D. Text*, ii, pp. 51-2.

(7) Ḥathor suckling boy-king as Horus, and god with harpoon, NESTOR L'HÔTE MSS.* 20396, 232 [left]; HAY*, 29816, 122 [left], 29847, 6 [left].

(8) Min, and Ḥathor suckling boy-king as Horus, NESTOR L'HÔTE MSS.* 20396, 232 [right]; HAY*, 29816, 122 [right], 29847, 6 [right].

(9) King offering and small son with birds before Sobk (?), King, Khnum, and Anubis, NESTOR L'HÔTE MSS.* 20396, 233.

(10)-(11) King and Horus, shrine (?), Thoth and King, id. ib. 230; HAY*, 29847, 5 verso [right lower], cf. 29813, 19 [middle right]; see BURTON MSS.* 25634, 38 [upper right].

(12) King offers to Amūn, Khnum, King (?), and human-headed god, NESTOR L'HÔTE MSS.* 20396, 231; HAY*, 29847, 5 verso [right upper] (sketch).

Exterior.

Figure in relief, Graeco-Roman, slightly south of entrance, *Descr. de l'Égypte, Ant.* iv, pl. 67 [19]; HAY*, 29813, 18; Greek texts, *L. D.* vi. 75 [17, 18], cf. *Text*, ii, p. 52; see KAMAL, op. cit. 236.

NECROPOLIS

Graeco-Roman Cemetery.

For position, see LEFEBVRE, *Sarcophages égyptiens trouvés dans une nécropole gréco-romaine à Tehneh* in *Ann. Serv.* iv, p. 228, fig. 1.

Sarcophagus with hawk-headed coffin containing Osiris mummy, 1st-2nd centuries A.D., in *Cairo Mus.*, id. ib. pl. ii, cf. p. 229; see MASPERO, *Guide* (1914), p. 337.



Cemetery of Dyn. XX-XXVI, west of Temple of Nero.

See ABOU SEIF, *Rapport sur les fouilles faites à Tehneh en janvier et février 1926* in *Ann. Serv.* xxvi. 32-8; LACAU, *Note sur la tombe No. 3 de Tehneh* in ib. 38-41; GAUTHIER, *Notes sur les statuettes funéraires* [&c.] in ib. 41-3.

Finds.

Sphinx with remains of cartouches of Ramesses III (?); text, LEFEBVRE, op. cit. in *Ann. Serv.* iv. 237 [bottom].

Canopic vase of Bekenmut , and ushabti; texts, id. ib. 238 [4°, 7°].

Mummy-cases, Late Period; texts with names of Ḥtept  and Unnūfer , id. ib. 239-40 [15°].

Board with sketches of negro and three heads, id. ib. p. 241, fig. 5.

Offering-table (uninscribed), *L. D. Text*, ii, p. 54; HAY*, 29857, 34 [bottom].

ROCK-STELAE

See WILKINSON, *Modern Egypt and Thebes*, ii. 37.

(1) Castor and Pollux, and Diana, BURTON MSS.* 25636, 4 [middle right]; WILKINSON MSS.* ii. 33 [top left]; WRZINSKI, *Bericht über die photographische Expedition* [&c.], pl. 11 [A]; see *L. D. Text*, ii, p. 52; BONOMI MSS.* *Diary*, Jan. 7, 1825.

(2) Figures of god (?) and Osiris, with Greek inscription of Ptolemy V Epiphanes above, HAY*, 29847, 26 [left]; WILKINSON MSS.* vi. 257 [top], xvii. k. 6; sketch, *L. D. Text*, ii, p. 52; see WILKINSON, *Modern Egypt and Thebes*, ii. 37.

(3) Ramesses III followed by Amen-rē' before Sebk-rē', NESTOR L'HÔTE MSS.* 20396, 236; HAY*, 29847, 56 [bottom left], 29857, 34 verso; WILKINSON MSS.* ii. 33 [top right], iii. 17 verso H [right], vi. 257 [middle]; text between King and Sebk-rē', KAMAL, *Fouilles à Tehneh* in *Ann. Serv.* iv. 236.

(4) Cartouche of Ramesses III, south of last, id. ib. 237; BURTON MSS.* 25636, 4 [top].

ROCK-CUT MASTABAS ('Fraser Tombs'). Dyn. V.

About two kilometres farther south.

NEKA-'ANKH , Steward of the Great Residence; Overseer of the New Towns; Overseer of prophets of Ḥathor of Ṭihna. (First tomb.) Temp. Userkaf. (13 of FRASER.)



Plan and section, FRASER, *The early Tombs at Tehneh* in *Ann. Serv.* iii, pl. i.

Hall.

(1)-(2) False door, and niche with statues of man, woman, and three sons; titles of statues, and text of will in favour of son Ḥem-Ḥathor , id. ib. 125 (omitting first line of will); title of son Ḥem-Ḥathor, and text of will, MASPERO, *Sur le sens de certains tableaux qui décorent la tombe de Noukankhou* in *Ann. Serv.* iii. 137; titles and will, SETHE, *Urk.* i. 30-1 (17) D.

(3)-(4) Three registers of offering-bringers behind deceased seated before list of offerings, and bringing animals below, FRASER, op. cit. pl. v; texts of priests and decree (destroyed) behind deceased, SETHE, *Urk.* i. 29-30 (17) C.

(5)-(7) House-façade, false door, and statues of deceased and wife in niche, FRASER, op. cit. pl. iii.

(8) North wall, statues of deceased, wife Ḥezet-ḥeknu , and man Ni'ankhesi ; texts, id. ib. 123-4; SETHE, *Urk.* i. 32 (17) E.

(9)-(12) Deceased and wife seated with offering-bringers below, and twelve offering-bringers, calendar, and will, before deceased and wife seated, FRASER, op. cit. pl. iv; calendar and will, and texts of deceased and wife at (9), SETHE, *Urk.* i. 24-9 (17) A, B; omitting text above deceased and wife, MASPERO, op. cit. 131-6; calendar and will, FRASER, op. cit. 126-7.

NEKA-'ANKH , Steward of the Great Residence; Prophet of Ḥathor of Ṭihna. (Second tomb.) Temp. Userkaf.

Passage.



(1) False door, titles of deceased, LEFEBVRE and MORET, *Un nouvel acte de fondation à Tehneh* in *Rev. Égypt. Nouv. Sér.* i (1919), pp. 30-1 note 3 a.

Hall.

(2) Statues of deceased and small son, with lintel above; titles on lintel, id. ib. p. 31 note 3 b.

(3) Will in favour of son Emref-'ankh ; text, id. ib. 3.

(4) Deceased before offerings, offering-list, and butchers below; titles of deceased, id. ib. 30.

(5)-(6) Statues of father Heti , mother Debit , two sons, and boy Nefertkau ; texts, id. ib. 31-2.

(7) Son Ḥem-Ḥathor  before deceased, and three servants below; titles of deceased, WRESZINSKI, *Bericht über die photographische Expedition* [&c.], p. 31.

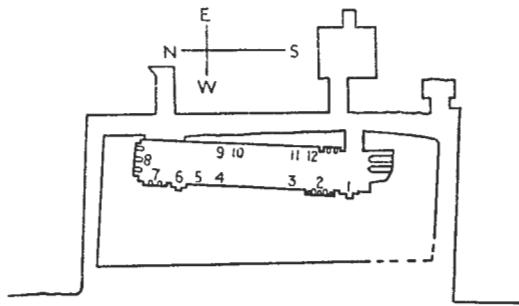

ṬIHNA. Neka'-ankh (First tomb). From FRASER in *Ann. Serv.* iii, pl. i.

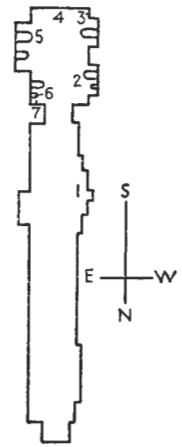

ṬIHNA. Neka'-ankh (Second tomb).

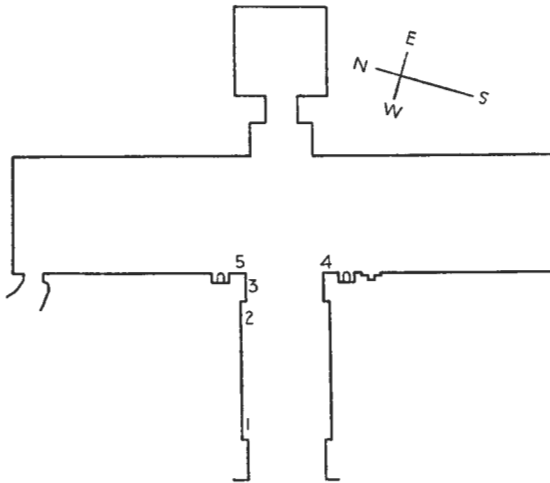

ṬIHNA. Khenu-ka.

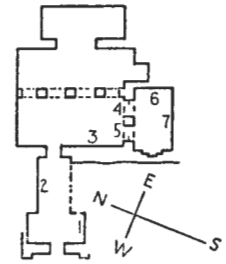

EL-KÔM EL-AḤMAR. Ni'ankh-Pepy. From *L. D.* i. 57 [Tomb 14].

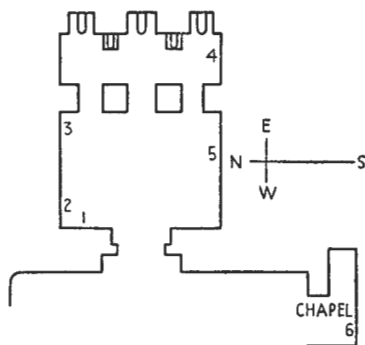

EL-KÔM EL-AḤMAR. Nefersokheru.

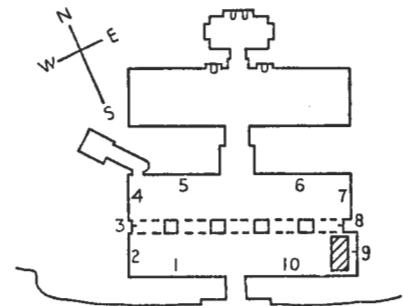

EL-KÔM EL-AḤMAR. Khunes. From *L. D.* i. 57 [Tomb 2].

NAME UNKNOWN. (9 of FRASER.)

Inner Passage.



West wall. Names of Meres'ankh , Concubine, and Wash-ka , Scribe, from false door, FRASER, op. cit. in *Ann. Serv.* iii. 70.

IFI  and wife (?) THENTI . (11 of FRASER.)

Names from false doors, id. ib. 71.

KAḤAP , Inspector of scribes of the house of the royal archives ; Royal acquaintance. (12 of FRASER.)

Names of deceased and his seal-bearer from north false door, id. ib. 72, 73.

Wooden headrest belonging to burial, found in shaft ; text of Khenu-ka  or , id. ib. 73.

KHENU-KA , Royal acquaintance ; Chief of Upper Egypt ; Overseer of the guilds of Upper Egypt. (Rock-tomb.) (14 of FRASER.)

Passage.



Lintel (lying on floor) from outer doorway, with list of nomes ; names, id. ib. 76.

(1)-(2) Top register, scribes, and men bringing oryx, cranes, and gazelle to deceased ; one title of deceased, id. ib. 75.

Entrance to Hall.

(3) Thickness. Head (rest destroyed) of father of deceased, Mery  ; name, id. ib. 75.

Hall.

(4) and (5) Jambs. Son Kaḥap  and daughter Debit  ; names, id. ib. 75.

SHEIKH MUBÂRIK

Near Nazlet el-Shurafa.

FORTRESS.

Bricks of King Menkheperre', Dyn. XXI ; cartouches, CHABÂN, *Fouilles à Achmounéin* in *Ann. Serv.* viii. 223 [iv] ; WAINWRIGHT, *El Hibah and esh Shurafa* [&c.] in *Ann. Serv.* xxvii. 76.

FINDS.

Lower part of statue of Kha'emwaset , son of Ramesses II, in Cairo Mus. ; text, CHABÂN, op. cit. 223 [iv] (incomplete) ; DARESSY, *Fragment de statue du prince Khâ-m-uas* in *Ann. Serv.* xvi. 255-6.

FOUND NEAR EL-MINYA

Three fragments of the Palermo Stone, found in neighbourhood of El-Minya, according to native report, in Cairo Mus. 39734, 39735, 44859, GAUTHIER, *Quatre nouveaux fragments de la Pierre de Palerme* in MASPERO, *Le Musée Égyptien*, iii, pls. xxiv-xxvii, xxx, cf. xxviii, xxix ; see id. *Quatre fragments nouveaux de la Pierre de Palerme au Musée du Caire* in *Comptes Rendus* (1914), plate opposite p. 490.

BETWEEN EL-FAIYÛM AND BENI ḤASAN
ZÂWYET EL-AMWÂT (OR EL-MAIYITÎN) AND
EL-KÔM EL-AḤMAR

STEP PYRAMID. DYN. III (?). (Destroyed.)

See WEILL, *Fouilles à Tounah et à Zaouiét el-Maietin* [&c.] in *Comptes Rendus* (1912), 488-9.

NECROPOLIS

Predynastic, Old Kingdom, Middle Kingdom, Ptolemaic.

General account, id. *Cat. des Antiquités Égyptiennes* [&c.] in *Bull. Soc. Français des Fouilles Archéologiques* (1913), passim.

Dyn. VI Tombs.¹ (Inaccessible.)

Plan of tombs, L. D. i. 57. Description, *Descr. de l'Égypte, Ant. Texte*, iv, pp. 355-60.

1. NAME UNKNOWN, Overseer of prophets; Chancellor of the King of Lower Egypt; Intimate.

Plan and section, L. D. i. 57 [bottom left]; plan, L. D. *Text*, ii, p. 57; PRISSE, *L'Art Égyptien*, i, *Architecture*, pl. 15 [lower left] 'Piliers des Hypogées de Zawiet el-Mayetin'. Titles, L. D. *Text*, ii, p. 57.

2. KHUNES , Overseer of commissions; Ruler of the Residence.

See L. D. *Text*, ii, pp. 58-9. Plan, *Descr. de l'Égypte, Ant.* iv, pl. 68 [11]; L. D. i. 57 [2]; PRISSE, op. cit. pl. 15 [lower right]; plan and description, SAINT-FERRIOL MSS.* *Diary*, Jan. 26, 1842.

Hall.

(1) Four registers, netting fowl, tending cattle, boatmen fighting, and cattle crossing inundation, before deceased and wife with children, and servants behind, L. D. ii. 105 a, b; texts, CHAMPOLLION, *Not. Descr.* ii. 442-5; first register, omitting one scribe and man with papyrus and fowl, ROSELLINI, *Mon. Civ.* lxxvi [1], lxxxiii [3], v; omitting drow-net, CHAMPOLLION, *Mon.* ccccv [1, 2, 3] (called 'tombeau de Ménofré'); part, *Descr. de l'Égypte, Ant.* iv, pl. 68 [17]; man with bull and cow from second register, CHAMPOLLION, *Mon.* cccci [4]; ROSELLINI, *Mon. Civ.* xxvi [4]; men in canoe bringing fowls from third register, CHAMPOLLION, *Mon.* ccccx [3] (called 'tombeau d'Eïmei'); ROSELLINI, *Mon. Civ.* vi [1]; boatmen fighting, PRISSE, *Mon.* xxxviii (marked xxxvii); PRISSE, *L'Art Égyptien*, ii, *Sculpture*, pl. 12 'Joué de Mariniers', cf. *Texte*, pp. 399-400; group on right, CHAMPOLLION, *Mon.* cccci [5]; ROSELLINI, *Mon. Civ.* cv [6]; DUEMICHEN, *Flotte*, xxviii [4]; fourth register, men in canoes and cattle crossing inundation, ROSELLINI, *Mon. Civ.* xxiv [4], xxviii [2]; DUEMICHEN, *Flotte*, xxviii [9]; first canoe and last group of cattle, CHAMPOLLION, *Mon.* cccci [3, 1]; text over first group of cattle, id. ib. cccci [5].

(2) Deceased harpooning fowl, and four registers (west part destroyed), papyrus-gathering, making canoes, milking, and netting fish, L. D. ii. 106 a; top register, five men carrying bundles of papyrus, *Descr. de l'Égypte, Ant.* iv, pl. 68 [16]; two men, CHAMPOLLION, *Mon.* cccci [4]; ROSELLINI, *Mon. Civ.* xxxvi [3].

(3) Pilaster. Figure of deceased, L. D. ii. 109 [left].

(4) Wife seated before offerings, and three registers, daughters, musicians, and dancers, L. D. ii. 109 [right]; part of text of wife, NESTOR L'HÔTE MSS.* 20396, 243 [lower right]; names of daughters, CHAMPOLLION, *Not. Descr.* ii. 446.

¹ The marginal tomb-numbers are those of LEPSIUS.

- (5) Counting cattle before deceased (destroyed); numbers of cattle, id. ib. 447 [top].
- (6) Men preparing food, dancers and musicians, and servant offering water to deceased in kiosk; texts of cooks, musicians, and man offering, id. ib. 447-8; deceased, PRISSE, *L'Art Égyptien*, i, *Architecture*, pl. 15 [upper] 'Piliers des Hypogées de Zawiet el-Mayetin', cf. *Texte*, p. 360; NESTOR L'HÔTE MSS.* 20396,243 [lower left]; omitting text and one floral column, L. D. ii. 110 a; two floral columns, AMÉLINEAU, *Hist. de la Sépulture et des Funérailles* in *Ann. Mus. Guimet*, xxviii, p. 234; harper, CHAMPOLLION, *Mon.* cccci [3]; ROSELLINI, *Mon. Civ.* xcvi [2].
- (7) Two sailing-boats and two rowing-boats; texts, CHAMPOLLION, *Not. Descr.* ii. 448-9 [top]; omitting first sailing-boat and first rowing-boat, CHAMPOLLION, *Mon.* cccci bis [top and bottom left]; ROSELLINI, *Mon. Civ.* cvi [1, 3]; one sailing-boat from upper register, *Descr. de l'Égypte, Ant.* iv, pl. 65 [3]; WILKINSON, *M. and C.* iii. 205 (No. 372) = ed. BIRCH, i. 277 (No. 90), ii. 221 (No. 410); WILKINSON MSS.* ii. 23 [bottom], iii. 17 verso G [middle left]; sketch, SAINT-FERRIOL MSS.* Diary, Jan. 26, 1842.
- (8) Pilaster. Five registers, making spears and bows, L. D. ii. 108 [left]; second and fourth registers, CHAMPOLLION, *Mon.* cccci [1, 2]; ROSELLINI, *Mon. Civ.* xliii [5]; CAILLIAUD, *Arts et Métiers*, pl. 15 A [1-6]; omitting one figure, and adding man sawing from fifth register, PRISSE, *Mon.* xliii [4].
- (9) Five registers, goats browsing, felling trees, and boat-building, L. D. ii. 108 [right]; top register, goats browsing (incomplete), CHAMPOLLION, *Mon.* cccci [3], cccci bis [4]; ROSELLINI, *Mon. Civ.* xxviii [3, 4]; two boats from fourth and fifth registers, DUEMICHEN, *Flotte*, xxix [top, right, and middle].
- (10) Deceased, followed by five rows of servants with dogs and baboon, watching four registers harvest, L. D. ii. 107, 106 b; texts, CHAMPOLLION, *Not. Descr.* ii. 450-4; first to third registers, *Descr. de l'Égypte, Ant.* iv, pl. 68 [13-15]; first plough and first group of goats from top register, CHAMPOLLION, *Mon.* cccci [2], cccci bis [3] (called Beni Hasan); ROSELLINI, *Mon. Civ.* xxxii [7, 3]; left part of flax harvest from second register (in wrong order), id. ib. xxxv [4, 2 top and middle]; omitting scribes, CHAMPOLLION, *Mon.* cccci bis [1, 2]; third register, carrying and piling grain, men with asses (in wrong order), ROSELLINI, *Mon. Civ.* xxxv [1, 2 bottom], xxxvi [1]; scribe and a palette, WILKINSON MSS.* iii. 17 verso G [lower middle right], xii. 13 [bottom]; fourth register, reapers, CHAMPOLLION, *Mon.* cccci [5], cccci bis [3-5]; ROSELLINI, *Mon. Civ.* xxxiii [1]; last three reapers, WILKINSON, *M. and C.* 2 Ser. i. 93 (No. 433) = ed. BIRCH, ii. 424 (No. 476) (called Thebes); man with sloughi-dog from second row behind deceased, CHAMPOLLION, *Mon.* cccci bis [3]; ROSELLINI, *Mon. Civ.* xvi [3].

3. MA Intimate; First under the King; Overseer of land.

Plan, L. D. i. 57 [3], and *Text*, ii, p. 59.

Outer Hall.

Titles of deceased and wife from two false doors, id. ib. p. 59 [bottom left].

Pillared Hall.

Titles of deceased and wife from scenes of watching cattle, funeral procession, offering-scene, and numbering cattle, &c., L. D. ii. 110 b, c, and *Text*, ii, p. 60 [upper]; deceased holding harpoon (?) with titles above [=L. D. 110 c], NESTOR L'HÔTE MSS.* 20396, 243 [upper].

4. IHY Intimate; Overseer of prophets.

Plan, L. D. i. 57 [4].

Outer Hall.

South Wall. Remains of scene of men with cattle and offering-bringers before deceased; titles, NESTOR L'HÔTE MSS.* 20396, 243 verso [lower]; part, L. *D.* ii. 110 d, and *Text*, ii, p. 60 [near bottom].

Architrave. Offering-text, see L. *D.* *Text*, ii, p. 60 [bottom].

5. ITI , Inspector of prophets of the *ka*-temple of Pepy; First under the King; Royal scribe of accounts in the Presence.



Plan, L. *D.* i. 57 [5].

Façade.

Architrave. Deceased receiving offerings; deceased and text, L. *D.* ii. 110 f; WILKINSON MSS.* xii. 13 [middle].

West of entrance. Figure of deceased, L. *D.* ii. 110 g; NESTOR L'HÔTE MSS.* 20396, 243 verso [upper]; name and titles, WILKINSON MSS.* iii. 17 verso G [top middle], xii. 13 [top]; part, CHAMPOLLION, *Not. Descr.* ii. 454 [bottom].

East of entrance. Figure of deceased; titles, L. *D.* ii. 110 e, and *Text*, ii, p. 61 [upper].

6. WEHEMKA  , *šsm-t* of the Oryx-nome; Royal acquaintance. (Destroyed.)

Plan, L. *D.* i. 57 [6].

Outer Hall.

South wall. Deceased and wife before offerings with offering-bringers, and remains of row of scribes below; texts of scribes, L. *D.* *Text*, ii, p. 61 [bottom]; NESTOR L'HÔTE MSS.* 20396, 242 [lower].





West wall, right of door. Titles of deceased, L. *D.* ii. 110 h, and *Text*, ii, p. 62 [top]; NESTOR L'HÔTE MSS.* 20396, 242 [upper].

7. NAME DESTROYED, Inspector of prophets of the *ka*-temple of Teti. (Unfinished.)

Plan, L. *D.* i. 57 [7].

Façade.

South of entrance. Deceased and wife, PRISSE, *Mon.* xv bis [2]; id. *Lettre à M. Champollion Figeac in Rev. Arch.* i (1844), 727; WILKINSON MSS.* iii. 17 verso G [top right], xii. 12 [lower right]; titles, L. *D.* ii. 110 i.

8. WEHEM'AZ (?)  , good name WEHEMI  .



Plan, L. *D.* i. 57 [8].

Remains of architrave, L. *D.* ii. 110 k.

- 8 a. NAME UNKNOWN.

Plan, L. *D.* i. 57 [8 a].

Inner Hall.

Remains of scene with son Khnemḥesef  ; titles, L. *D.* *Text*, ii, p. 62 [bottom].

9. SHEPSEKAU , Inspector of prophets of the *ka*-temple of Pepy II ;
Scribe of the royal archives in the Presence ; Overseer of scribes.
Plan, L. D. i. 57 [9].

Façade.

Titles of deceased and wife to right of doorway, L. D. *Text*, ii, p. 63 [upper].

Hall.

West wall. Three false doors of deceased, wife, and Hūu ; texts, L. D. ii. 110 l-n, and *Text*, ii, p. 63 [lower]; titles of wife, WILKINSON MSS.* xii. 12 [lower left].

10. BIU , Mayor.

Plan, L. D. i. 57 [10].

Hall.

West wall. North stela, of wife, PRISSE, *Mon.* xv bis [3]; L. D. ii. 110 o; name and titles, L. D. *Text*, ii, p. 64 [near top]. South stela, of deceased; remains of text, L. D. ii. 110 p, and *Text*, ii, p. 64 [top].

11. MA , Intimate ; First under the King.

Plan, L. D. i. 57 [11].

Hall.

West wall. Stela of wife and smaller stela; name of woman from latter, L. D. ii. 110 q [left], cf. *Text*, ii, p. 64 [middle].

Recess. Stelae of deceased and man Abu ; names and titles, L. D. ii. 110 q [middle and right], and *Text*, ii, p. 64 [middle].

12. KHETETI , Intimate ; First under the King.

Plan, L. D. i. 57 [12].

Façade.

Figure of deceased on either side of doorway; right side, PRISSE, *Mon.* xv bis [4]; titles, L. D. ii. 110 r (both sides placed together), and *Text*, ii, p. 64 [bottom].

Outer Hall.

Entrance to Inner Hall (probably). Deceased seated on either side of doorway with offering-texts, NESTOR L'HÔTE MSS.* 20396, 242 verso [bottom].

13. HENENU , Ruler of the Residence ; Intimate.

Plan, L. D. i. 57 [13].

West wall. Stela ; titles, L. D. *Text*, ii, p. 65 [top].

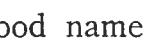
14. NI'ANKH-PEPY , good name KHNEMḤOTP-ḤEPI ,
Ruler of the Residence ; Intimate ; First under the King ;
Overseer of reports in the nine pools. (See plan, supra p. 132.)

See VARILLE, forthcoming publication in *Mém. Inst. Fr. Arch. Or.* Plan, L. D. i. 57 [14].

Outer Hall.

(1) Two registers, goats browsing and men felling trees, cooking and carpenters, L. D. ii. 111 b.

Passage.

(2) Deceased before offerings, and offering-bringers; text of deceased, L. *D.* ii. 111 i.

Pillared Hall.

(3) Flax harvest, &c., before deceased and wife; text, L. *D.* ii. 111 h, and *Text*, ii, p. 66 [right].

Architraves of pillars (destroyed); texts, L. *D.* ii. 111 c, g, cf. *Text*, ii, p. 66 [upper middle].

Entrance to Side-room.

(4) Thickness; title of Ḥepi 𓆎𓅓 , L. *D.* *Text*, ii, p. 66 [lower middle].

(5) Thickness; deceased and wife with titles, L. *D.* ii. 111 d.

Side-room.

(6) Four registers, date-gathering and wine-making, L. *D.* ii. 111 a.

(7) Offerings, offering-bringers, butchers, and musicians, before deceased and wife in kiosk; capital of pillars of kiosk, and basket with offerings, L. *D.* ii. 111 e, f.

16. ḤATHEREMḤĒT 𓆎𓅓𓆎𓅓 (probably wife of owner), Unique royal ornament; Royal acquaintance.

Plan, L. *D.* i. 57 [16].

Inner Hall.

West wall. Stela of deceased; texts, L. *D.* *Text*, ii, p. 67 [bottom].

17. MERERI 𓆎𓅓 , Inspector of prophets of the *ka*-temple of Pepy II; Chancellor of the King of Lower Egypt; Intimate; Overseer of gardens of the Great Residence.

Plan, L. *D.* i. 57 [17].

Fourth Hall.

West wall. Stela of deceased; texts, L. *D.* *Text*, ii, p. 68 [top]; jambs, L. *D.* ii. 111 k.

18. IT 𓆎𓅓 .

Plan, L. *D.* i. 57 [18].

Hall.

Unfinished stela; name of deceased, L. *D.* *Text*, ii, p. 68 [middle].

19. NEḤERI 𓆎𓅓 , Intimate, and PAAKHUT 𓆎𓅓𓆎𓅓 , Prophetess of Ḥathor; Unique royal ornament.

Plan, L. *D.* i. 57 [19].

Sketches of two men in a boat, and man with arms outstretched, perhaps from this tomb, NESTOR L'HÔTE MSS.* 20396, 242 verso [top].

Inner Hall.

West wall. North stela, of Paakhut; text, L. *D.* *Text*, ii, p. 68 [bottom]; jambs, L. *D.* ii. 111 l.

South stela (unfinished), of Neheri; titles, *L. D. Text*, ii, p. 69 [top]; NESTOR L'HÔTE MSS.* 20396, 242 verso [middle right].

Probably from one of these tombs.

Offering-bringers, PRISSE, *Mon.* xv bis [5].

NEW KINGDOM TOMB¹ (Accessible).

NEFERSEKHERU , Royal scribe; Great Steward of the Lord of the Two Lands; Overseer of the granaries of Upper and Lower Egypt. Late Dyn. XVIII or Dyn. XIX. (See plan, supra p. 132.)

Plan, description, and sketch of rear wall, SAINT-FERRIOL MSS.* Diary, Jan. 26, 1842; plan, *L. D. Text*, ii, p. 55. Name and titles, WRZINSKI, *Bericht über die photographische Expedition* [&c.], p. 33.

Hall.

(1) Upper part, offering-list and offering-bringers before deceased and wife; titles, *L. D. Text*, ii, p. 55 [bottom]; WILKINSON MSS.* iii. 17 verso G [bottom right], xii. 12 [upper]; other titles, CHAMPOLLION, *Not. Descr.* ii. 439. Lower part, mummy on bier with wife mourning on either side and mourning hymns, KEES, *Ein Klage lied über das Jenseits* in *Ä.Z.* lxii, p. 75, Abb. 2, and p. 76.

(2) Hymn to Osiris, and deceased kneeling before slain animals below; beginning of hymn, CHAMPOLLION, *Not. Descr.* ii. 440 [top]; id. *Mon.* cccci [1].

(3) Deceased and wife led by Horus to four sons of Horus, Osiris, and Nephthys; texts of Horus and of wife, *L. D. Text*, ii, p. 56.

(4) Deceased and wife standing before two shrines, and female and male figures offering at pools, WILKINSON MSS.* xii. 11.

(5) Three registers, funeral procession. Top register, mourners before mummy at tomb; tomb, CHAMPOLLION, *Mon.* cccci [2]; ROSELLINI, *Mon. Civ.* lxxviii [1]; PRISSE, *L'Art Égyptien, Texte*, p. 217; see CHAMPOLLION, *Not. Descr.* ii. 454. Second and third registers, men bringing funerary equipment with women mourners, and funeral feast; men with funerary equipment, and deceased with wife and sister at feast, KEES, op. cit. p. 74, Abb. 1.

Floral column from one of the scenes, PRISSE, op. cit. *Architecture*, pl. 17 [5] 'Constructions en bois—colonnnettes des édicules', cf. *Texte*, p. 362.

Ceiling. Offering-texts, see CHAMPOLLION, *Not. Descr.* ii. 440. Decoration, CHAMPOLLION, *Mon.* cccxxxvii quat [right]; ROSELLINI, *Mon. Civ.* lxxii [21, 22, 24].

Chapel south of tomb.

(6) Naos with ape in niche, CHAMPOLLION, *Not. Descr.* ii. 441.

MISCELLANEOUS

Stela of Amenophis III, found in modern cemetery, now in Cairo Mus.; cartouches, LEFEBVRE, *À travers la Moyenne-Égypte* in *Ann. Serv.* xii. 93 [vii].

Lid of coffin of Semtu-ardais , Saite, in Cairo Mus.; text, id. ib. 93 [vi].

Upper part of figure of man offering, New Kingdom, 'on stone opposite El-Minya', WILKINSON MSS.* ii. 34 [top].

¹ Inscriptions copied by Fraser about 1898 are in the library of the late Professor Griffith at Oxford.

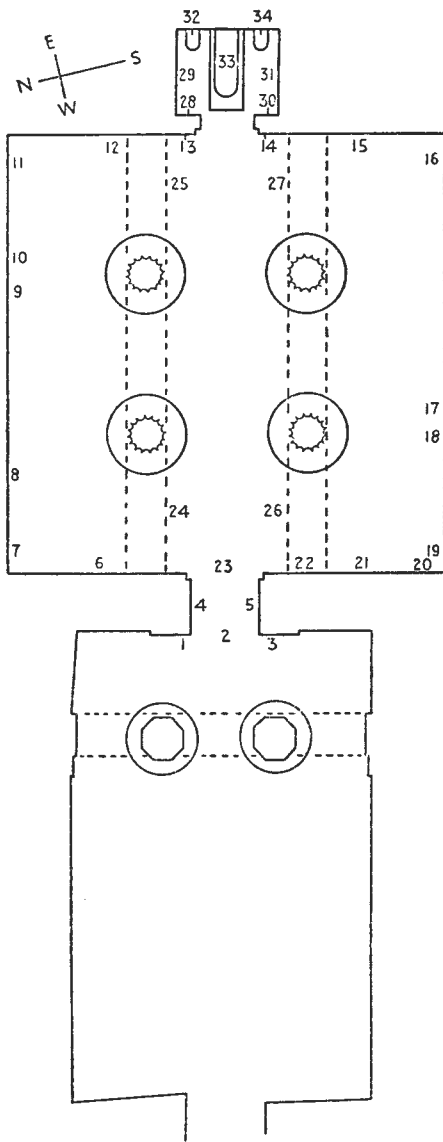

Tomb 2. Amenemhêt. From NEWBERRY and GRIFFITH, *Beni Hasan*, i, pl. iv.

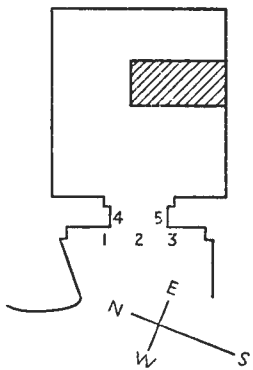

Tomb 13. Khnemhotp II. From NEWBERRY and GRIFFITH, *Beni Hasan*, i, pl. xli.

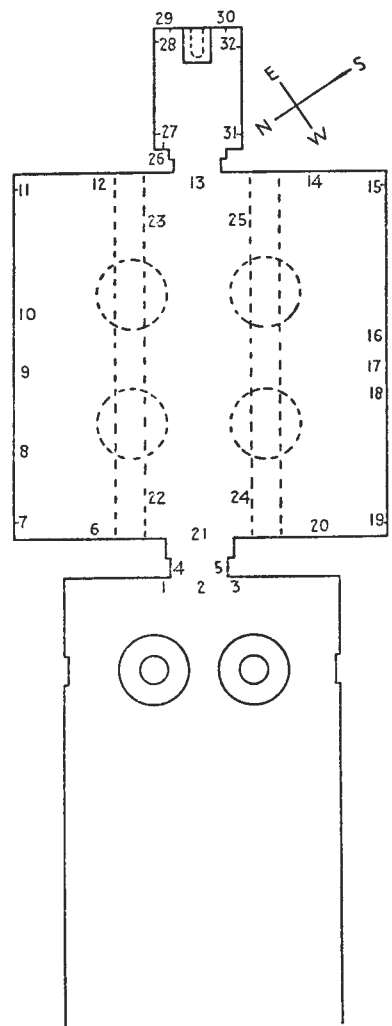

Tomb 3. Khnemhotp III. From NEWBERRY and GRIFFITH, *Beni Hasan*, i, pl. xxii.

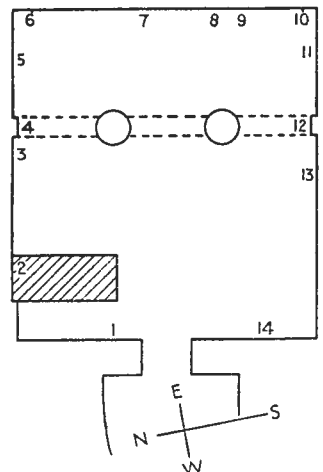

Tomb 14. Khnemhotp I. From NEWBERRY and GRIFFITH, *Beni Hasan*, i, pl. xliii.

VIII. BENI HASAN AND SPEOS ARTEMIDOS

BENI HASAN

NECROPOLIS

See GARSTANG, *The Burial Customs of Ancient Egypt*, passim. Map of site, id. ib. pl. ii opposite p. 15.

Rock-tombs.¹ Dyn. XII.

Complete, NEWBERRY and GRIFFITH, *Beni Hasan*, four vols. passim, with drawings by CARTER, BLACKDEN, BROWN, and BUCKMAN, in vol. iv. Description, texts from scenes, and bibliography, MONTET, *Notes sur les tombeaux de Béni-Hassan* in *Bull. Inst. Fr. Arch. Or.* ix. 1-36; description, NESTOR L'HÔTE MSS.* 20396, 239; BONOMI MSS.* Diary, Jan. 10, 1825; SAINT-FERRIOL MSS.* Diary, May 13-14, 1842. General plan, NEWBERRY and GRIFFITH, op. cit. i, pl. ii; L. *D.* i. 58; BURTON MSS.* 25634, 39; HAY*, 29847, 11 verso-12; sketch-plans, CHAMPOLLION, *Not. Descr.* ii. 433, 456. Views, *Descr. de l'Égypte, Ant.* iv, pl. 64 [1], cf. *Texte*, iv, p. 335 et seq.; ROSELLINI, *Mon. Civ.* i [1]; L. *D.* i. 61 [upper]; HAY*, 29813, 24, 24**, 29847, 33.

2. AMENEMHËT , Nomarch and Commander-in-chief of the Oryx-nome; &c. Temp. Sesostris I. (1 of LEPSIUS; 4 of CHAMPOLLION.)

Complete, NEWBERRY and GRIFFITH, op. cit. i, pp. 9-38, pls. iii-xxi; see CHAMPOLLION, op. cit. ii. 458 [4]. Plans, sections, and elevations, NEWBERRY and GRIFFITH, op. cit. pls. iv-v A, p. 19; *Descr. de l'Égypte, Ant.* iv, pl. 64 [3-7]; ROSELLINI, *Mon. Civ.* ii [7], iii; plan and sections, L. *D.* i. 59, cf. 58 [1]; HAY*, 29847, 8, 38 verso-39; plans and elevation, BURTON MSS.* 25636, 12; plan, CHAMPOLLION, op. cit. ii. 426 [top left]; L. *D. Text*, ii, p. 71; WILKINSON MSS.* ii. 22 verso [No. 1]. View, TEYNARD, *Égypte et Nubie*, pl. 13; of interior, JÉQUIER, *L'Architecture*, i, pl. 12 [2]; CAPART, *L'Art égyptien* (1911), pl. 127; id. *L'Architecture* (1922), pl. 70.

Entrance to Hall.

(1)-(3) Lintel and jambs, texts with deceased seated below, L. *D.* ii. 121; HAY*, 29813, 87; omitting deceased, CHAMPOLLION, *Mon.* cccxcix; NEWBERRY and GRIFFITH, op. cit. i, pl. vii, cf. pp. 21-3; top line of lintel and parts of jambs, WILKINSON MSS.* i. 80 [top], v. 4 [top and upper middle], 5 [top], x. 17, 18 [left and upper].

(4) and (5) Thicknesses, biographical text, NEWBERRY and GRIFFITH, op. cit. i, pl. viii, cf. pp. 23-7; L. *D.* ii. 122; HAY*, 29813, 84 [left], 84 verso [left]; north thickness, CHAMPOLLION, *Mon.* cccxcv [4]; id. *Not. Descr.* ii. 427-30; REINISCH, *Aegyptische Chrestomathie*, pl. 5; texts, MASPERO, *La grande inscription de Béni-Hassan* in *Rec. de Trav.* i. 171-4, reprinted in *Bibliothèque Ég.* viii. 168-72; horizontal text at top of south thickness, WILKINSON MSS.* ii. 22 verso [right middle], v. 4 [lower middle], x. 25; NESTOR L'HÔTE MSS.* 20396, 240.

Hall.

(6) Seven registers, knife-makers and leather-workers, carpenters, goldsmiths, potters, linen-makers, harvest, ploughing, &c., NEWBERRY and GRIFFITH, op. cit. i, pl. xi; cf. iii, pl. viii; iv, pls. xx [1, 2], xxvii [1, 2, 3]; HAY*, 29813, 29, 57; fourth to seventh registers, WILKINSON MSS.* ii. 24 [top, middle group from second row, and third row], 24 verso,

¹ The marginal tomb-numbers are those of NEWBERRY and GRIFFITH.

25 [top]; man sawing wood from second register, *id. ib.* 27 A [12, top]; scales from third register, HAMILTON, *Aegyptiaca*, xxi [6]; WILKINSON MSS.* ii. 24 [near top right]; fifth register, flax-growing and linen-making, WILKINSON, *M. and C.* iii. 138 (No. 356) = ed. BIRCH, ii. 173 (No. 389); BURTON MSS.* 25634, 47 verso; linen-makers, HAMILTON, *Aegyptiaca*, xxi [5, 7]; three men preparing flax, *Descr. de l'Égypte, Ant.* iv, pl. 65 [2' right]; two men twisting rope, WILKINSON MSS.* ii. 23 verso [lower right]; sixth register, harvest, CHAMPOLLION, *Mon.* cccc; ROSELLINI, *Mon. Civ.* xxxvi [2]; omitting first group, *Descr. de l'Égypte, Ant.* iv, pl. 65 [2]; BURTON MSS.* 25634, 46; oxen threshing, WILKINSON, *M. and C.* 2 Ser. i. 87 (No. 429) = ed. BIRCH, ii. 420 (No. 472); seventh register, second group of ploughing and sowing, *id. ib.* 2 Ser. i. 40 (No. 422) = ed. BIRCH, ii. 391 (No. 465); BURTON MSS.* 25634, 47 [lower]; man and oxen, HAY*, 29850, 232-7 (tracings); part, *Descr. de l'Égypte, Ant.* iv, pl. 65 [2' left]; man with third plough, two ploughs, and hoe, CHAMPOLLION, *Mon.* cccxcviii [3]; ROSELLINI, *Mon. Civ.* xxxii [4-6]; man with third plough, CAILLIAUD, *Arts et Métiers*, pl. 34 A [4].

(7)-(11) Six registers, hunting, funeral procession, and bringing produce to deceased, NEWBERRY and GRIFFITH, *op. cit.* i, pl. xiii, cf. pp. 37-8, pl. xxi [3]; iv, pls. ii, xxiii [2], xxiv [2]; HAY*, 29813, 30-1, 58-9; texts, *L. D. Text*, ii, pp. 83 [middle]-85 [lower middle]; two men shooting gazelle from top register, *Descr. de l'Égypte, Ant.* iv, pl. 66 [4]; panther from top register, HAY*, 29850, 252-3 (tracing); girls with necklaces and five male acrobats from second register, WILKINSON MSS.* ii. 29 A; four offering-bringers from third register, HAY*, 29850, 238, 245, 246, 248-51 (tracings); beginning of text above men drawing shrine in second register, hieratic text above bulls fighting in fifth register, and texts of boxes and vases behind deceased, MONTET, *op. cit.* in *Bull. Inst. Fr. Arch. Or.* ix, pp. 3 [bottom]-4 [top] and pl. ii [1, 2]; text above one bull, WILKINSON MSS.* x. 18 [lower right]; man leading ibex and kid, overseer with defaulter, scribe Nakht standing, and scribe Khnemhotp seated, from sixth register, *id. ib.* ii. 24 [top middle, top right], 27 A [14 upper]; granary with hieratic texts from sixth register, ROSELLINI, *Mon. Civ.* xxxiv [2]; omitting texts, CHAMPOLLION, *Mon.* cccxcviii [1]; texts of lower granaries, *id. Not. Descr.* ii. 431-2; sketch of granary, BURTON MSS.* 25636, 13 [lower]; first group of defaulters brought to scribe, and three gazelles (?) with kid, from sixth register, *id.* 25634, 48, 55; hieratic inscription on palette presented by scribe to deceased [NEWBERRY and GRIFFITH, i, pl. xxi (3)], CHAMPOLLION, *Not. Descr.* ii. 434 [lower left]; two dogs in front of deceased, WILKINSON MSS.* ii. 27 A [11 lower].

Frieze. Texts, *L. D. Text*, ii, p. 85 [bottom].

(12) Top to third registers, wrestlers, fourth register, attack on fortress, fifth register, voyage to Abydos, NEWBERRY and GRIFFITH, *op. cit.* i, pl. xiv, cf. p. 38; HAY*, 29813, 32, 60; one pair of wrestlers from second register, *Descr. de l'Égypte, Ant.* iv, pl. 66 [1, upper left]; CAILLIAUD, *op. cit.* pl. 39 [middle left]; two archers from fortress scene, CHAMPOLLION, *Mon.* cccxcvi [1]; ROSELLINI, *Mon. Civ.* cxvii [6]; archer adjusting bow-string, MONTET, *op. cit.* pl. iii; two men with battering-ram and archer attacking fortress, WILKINSON, *M. and C.* i. 360 (No. 60, 2) = ed. BIRCH, i. 242 (No. 74, 2); WILKINSON MSS.* ii. 23 B [bottom right], 24 [top left]; omitting archer, *L. D. Text*, ii, p. 82 [bottom]; two men with battering-ram, BURTON MSS.* 25636, 13 [upper]; voyage to Abydos, WILKINSON MSS.* ii. 23 verso [upper, and lower left]; boat with mummy from fifth register, *Descr. de l'Égypte, Ant.* iv, pl. 65 [4]; text at top of fifth register and text above boat with mummy, *L. D. Text*, ii, p. 83 [top]; part of text at top, WILKINSON MSS.* x. 26 [upper]; text above boat, hieratic text in front of third boat, and stern of second boat, MONTET, *op. cit.* p. 4 [middle], pls. ii [3], x [2].

(13)-(14) Doorway to shrine, and wrestlers above, NEWBERRY and GRIFFITH, *op. cit.*

i, pl. xv, cf. pp. 28-9; lintel and jambs, HAY*, 29813, 86; wrestlers and titles of deceased above, id. ib. 33, 61, cf. 79, 80 [right]; titles above, WILKINSON MSS.* v. 5 [middle]; three pairs of wrestlers, *Descr. de l'Égypte, Ant.* iv, pl. 66 [1, upper (omitting left pair)]; CAILLIAUD, op. cit. pl. 39 [middle (omitting left pair)].

(15) Top to third registers, wrestlers, fourth and fifth registers, fight, sixth register, voyage to Abydos, NEWBERRY and GRIFFITH, op. cit. i, pl. xvi; cf. iv, pl. xxiii [3]; fourth to sixth registers, HAY*, 29813, 34, 62; some wrestlers, BURTON MSS.* 25634, 50 [lower]; two archers, a soldier and two Berbers, from fourth and fifth registers, CHAMPOLLION, *Mon.* cccxcv [3], cccxcvi [2, 3 left]; ROSELLINI, *Mon. Civ.* cxvi [6, 7, 8], cxvii [5]; soldier and one Berber, CAILLIAUD, op. cit. pl. 43 A [2]; three Berbers, L. D. ii. 141, cf. *Text*, ii, pp. 81 [lower]-82 [top]; MEYER, *Darstellungen der Fremdvölker*, 45; WRZESZINSKI, *Atlas*, ii. 7; third boat with women from sixth register, CHAMPOLLION, *Mon.* ccclxxvii ter [lower]; ROSELLINI, *Mon. Civ.* cv [1]; WILKINSON MSS.* x. 24 [bottom]; text above boats, L. D. *Text*, ii, p. 82 [middle]; hieratic texts above boats, MONTET, op. cit. pl. ii [4-7].

(16)-(17) Upper part, deceased before offerings, offering-list, and four registers priests with offerings, lower part, two registers offering-bringers and butchers, NEWBERRY and GRIFFITH, op. cit. i, pl. xvii, cf. p. 38; iv, pl. xiv; cf. iii, pls. ix [3, 4, 5], x; iv, pls. xvii, xviii, xix, xxii [upper left], xxvi; HAY*, 29813, 35-6 [left], 63-4 [left]; texts, L. D. *Text*, ii, pp. 78 [lower]-81 [middle]; part of heading of offering-list, and titles of deceased, CHAMPOLLION, *Not. Descr.* ii. 426 [top right], 434 [upper]; fruit on altar in front of deceased, ROSELLINI, *Mon. Civ.* xl [7]; upper part, top register of priests, WILKINSON MSS.* ii. 27 A [11 upper]; two of the priests, BISSING, *Denkmäler, Text* to 34; lower part, gazelle from upper register, L. D. ii. 152 g.

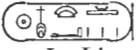
(18)-(19) Upper part, wife before offerings, offering-list and four registers priests, lower part, male and female offering-bringers, and butchers, NEWBERRY and GRIFFITH, op. cit. i, pl. xviii; cf. iii, pl. ix [6, 7]; HAY*, 29813, 36 [right], 64 [right]; texts, L. D. *Text*, ii, pp. 75-8 [middle]; titles of wife, CHAMPOLLION, *Not. Descr.* ii. 434 [lower right]; HAY*, 29850, 255-64; lower part, calf with hieratic text from upper register, L. D. ii. 152 h; hieratic text, CHAMPOLLION, *Not. Descr.* ii. 431 [2]; hieratic text above calf with name of unknown king Neferkha'urē' , Dyn. XII or XIII, L. D. *Text*, ii, p. 76 [middle] with note 2; see GAUTHIER, *Le Livre des Rois*, ii. 94 [14] with note 2; head of calf, and transcription of hieratic text in front of herdsman, MONTET, op. cit. pl. v [1], and p. 4 [bottom]; girl carrying basket on which is hieratic text, NEWBERRY and GRIFFITH, op. cit. i, pl. x; lower register, text and details of slaughtering scene, MONTET, op. cit. p. 5 [top], and pls. iv [1-3], v [3].

(20)-(22) Upper part, top and second registers, vintage with goats browsing, third and fourth registers, fishing with net, netting fowl, and preparing and bringing fish to deceased and family, fifth register, preparing food and drink, NEWBERRY and GRIFFITH, op. cit. i, pl. xii [upper]; HAY*, 29813, 37 [upper], 65 [upper]; man with basket of grapes, and man and boy with baskets, from vintage scenes, CHAMPOLLION, *Mon.* cccxcv [2]; ROSELLINI, *Mon. Civ.* xxxvii [2]; treading and pressing grapes, man and boy with basket of grapes, and goats browsing, from top and second registers, WILKINSON MSS.* ii. 27 A [10]; man and boy, and goats, id. *M. and C.* ii. 151 (No. 139) = ed. BIRCH, i. 383 (No. 159); BURTON MSS.* 25634, 47 [upper]; goats, HAY*, 29850, 239-41 (tracings); text on scribe's palette from top register, NEWBERRY and GRIFFITH, op. cit. i, pl. xxi [1, 2]; marsh-plants, and man preparing fish, from third and fourth registers, ROSELLINI, *Mon. Civ.* xl [5, 6], xxv [3]; preparing bread and meat, from fifth register, CHAMPOLLION, *Mon.* cccxcv [1], cccxcviii [2]; ROSELLINI, *Mon. Civ.* lxxxiii [2], lxxxvii [4].

(20) Lower part, three registers, male and female attendants and harpers, NEWBERRY and GRIFFITH, op. cit. i, pl. xii [lower left]; iv, pl. xvi; CHAMPOLLION, *Mon.* cccxcvii [1-4]; ROSELLINI, *Mon. Civ.* lxxvii [12]; HAY*, 29813, 37 [lower left], 65 [lower left]; second and third registers, WILKINSON MSS.* ii. 22 verso [left, middle and lower]; omitting clappers, BURTON MSS.* 25634, 57; hieratic texts on caskets and mirror, L. D. *Text*, ii, p. 75 [middle with α, β]; transcriptions and details, MONTET, op. cit. p. 3 [top], and pl. i [1-8]; ROSELLINI, *Mon. Civ.* lxxvii [12 lower]; second register, woman with revolving fan, female and male harpers, WILKINSON, *M. and C.* ii. 238 (No. 192)=ed. BIRCH, i. 442 (No. 217); female harper, *Descr. de l'Égypte, Ant.* iv, pl. 66 [9]; text above singers from third register, CHAMPOLLION, *Not. Descr.* ii. 427 [top].

(21) Painted false door, NEWBERRY and GRIFFITH, op. cit. i, pl. xii [lower middle]; HAY*, 29813, 37 [lower middle], 65 [lower middle]; upper part, WILKINSON MSS.* ii. 22 verso [middle lower]; texts, L. D. *Text*, ii, p. 74.

(22) Top and second registers, bread-making, third register, cattle crossing inundation, NEWBERRY and GRIFFITH, op. cit. i, pl. xii [lower right]; HAY*, 29813, 37 [lower right], 65 [lower right]; women kneading from top register, WILKINSON, *M. and C.* iii. 162 (No. 362)=ed. BIRCH, ii. 190 (No. 396); second register, WILKINSON MSS.* ii. 25 [right, near bottom]; boat and two heads of cattle from third register, id. *M. and C.* 2 Ser. i. 102 (No. 437, pt. i)=ed. BIRCH, ii. 429 (No. 480, pt. i); part, WILKINSON MSS.* ii. 25 [left lower, near bottom]; marsh-plants, L. D. *Text*, ii, p. 75 [top]; ROSELLINI, *Mon. Civ.* xl [3, 4].

(23) Above doorway, titles of deceased below frieze, NEWBERRY and GRIFFITH, op. cit. i, p. 31.

Pillars.

(24)-(25), (26)-(27) Architraves. Texts, id. ib. i, pl. ix, pp. 27-8; L. D. *Text*, ii, pp. 72-3; HAY*, 29813, 84 [right], 84 verso [right].

Shrine.

(28)-(29) Four registers priests and offering-bringers, and offering-list, NEWBERRY and GRIFFITH, op. cit. i, pl. xix; texts, L. D. *Text*, ii, pp. 86 [bottom]-87 [top]; two priests from top register, WILKINSON MSS.* ii. 27 A [12 middle].

(30)-(31) Four registers priests and offering-bringers, and offering-list, NEWBERRY and GRIFFITH, op. cit. i, pl. xx; texts, L. D. *Text*, ii, pp. 86 [middle], 87 [middle].

(32), (33), (34) Statues (destroyed) of deceased between wife and mother; texts, NEWBERRY and GRIFFITH, op. cit. i, pp. 34-6, cf. 37; of wife and mother, L. D. *Text*, ii, p. 86 [top]; on base of statue of deceased, HAY*, 29813, 86 [bottom].

Ceiling. Text, NEWBERRY and GRIFFITH, op. cit. i, p. 34 [middle]. Decoration, id. ib. pl. vi.

Hieratic graffito, position not recorded, id. ib. pl. xxi [4], cf. p. 38.

3. KHNEMHOTP III $\overline{\text{KHN}} \overline{\text{MHT}} \overline{\text{P}} \overline{\text{III}}$, Overseer of the Eastern Tribes; Mayor of Menat-Khufu; &c. (2 of LEPSIUS and ROSELLINI; 3 of CHAMPOLLION.)

Complete, NEWBERRY and GRIFFITH, *Beni Hasan*, i, pp. 41-72, pls. xxiv-xxxviii; see CHAMPOLLION, *Not. Descr.* ii. 458 [3]; NESTOR L'HÔTE MSS.* 20396, 241. Plans, sections, and elevations, NEWBERRY and GRIFFITH, op. cit. i, pls. xxii-xxiii A, cf. p. 52; L. D. i. 60 [left], cf. 58 [2]; plan, BURTON, *Excerpta Hiero.* xxxii [lower]; id. MSS.* 25634, 42 [lower], 43, 63; WILKINSON MSS.* ii. 22 verso [No. 2]; elevation, ROSELLINI, *Mon. Civ.* ii [4]. Views, HAY*, 29813, 25-8; BURTON MSS.* 25634, 40.

Entrance to Hall.

(1)-(3) View of exterior, NEWBERRY and GRIFFITH, op. cit. i, frontispiece; TEYNARD, *Égypte et Nubie*, pl. 14; ROBERTS, *Egypt and Nubia* (1846), i, pl. 40; MARIETTE, *Voyage*, pl. 17; JÉQUIER, *L'Architecture*, i, pl. 12 [1]; STEINDORFF, *Die Kunst der Ägypter*, 117 [left]; HAY*, 29813, 24*, 29847, 7 verso; NESTOR L'HÔTE MSS.* 20396, 241. Lintel, and jambs with deceased seated at bottom, NEWBERRY and GRIFFITH, op. cit. i, pl. xxiv [upper (omitting A, B)], cf. pp. 53-5; L. D. ii. 123 f; CHAMPOLLION, *Not. Descr.* ii. 386 [upper]; HAY*, 29813, 88; omitting deceased, BURTON, *Excerpta Hiero.* xxxii [middle]; BRUGSCH, *Thes.* 232 [B], 1526; BURTON MSS.* 25634, 42 [upper middle], 62; lintel, BRUGSCH, *Monumens*, xvii [11]; names from lintel, WILKINSON MSS.* v. 2 [lower left].

(4) and (5) Thicknesses. One column text on each side, NEWBERRY and GRIFFITH, op. cit. i, pl. xxiv [A, B], cf. p. 55; CHAMPOLLION, *Not. Descr.* ii. 386 [upper middle]; L. D. ii. 123 f [middle]; BURTON, *Excerpta Hiero.* xxxii [left, right]; id. MSS.* 25634, 42 [upper, left and right]; HAY*, 29847, 62 verso [lower].

Hall.

(6) Six registers, weighing and scribes, harvest, ploughing, voyage to Abydos, orchard and vineyard, cattle in inundation and fishing, NEWBERRY and GRIFFITH, op. cit. i, pl. xxix [right]; L. D. ii. 127; HAY*, 29813, 39 [right], 67 [right]; scales from top register, CHAMPOLLION, *Mon.* ccclvii [2]; ROSELLINI, *Mon. Civ.* lii [1]; fourth register, two boats on voyage to Abydos, id. ib. cxxxiii [1]; DUEMICHEN, *Flotte*, xxviii [1, 3]; sailing-boat, WILKINSON MSS.* ii. 25 verso [fourth row, right]; vineyard, orchard with monkeys in fig-tree, and garden with palm-tree, from fifth register, ROSELLINI, *Mon. Civ.* xxxix [3, 2], xl [1, 8]; omitting palm-tree, CHAMPOLLION, *Mon.* ccclvii [3], ccclviii [1, 2]; CAILLIAUD, *Arts et Métiers*, pls. 34 A [1, 2], 33 A [2-4]; vineyard, man in orchard, and two gardeners watering, WILKINSON, *M. and C.* ii. 147 (No. 133, called Thebes), 150 (No. 138), 137 (No. 124) = ed. BIRCH, i. 380 (No. 153), 382 (No. 158), 373 (No. 144); WILKINSON MSS.* ii. 25 [left upper, near bottom], 25 verso [bottom left], 27 A [14 lower]; men picking grapes, MONTET, op. cit. in *Bull. Inst. Fr. Arch. Or.* ix, pl. vi; man and fig-tree with monkeys, BOUSSAC, *Le perroquet* in *Rec. de Trav.* xxxiii, p. 58, fig. 2; one monkey, CHAMPOLLION, *Mon.* ccccxviii ter [top middle]; ROSELLINI, *Mon. Civ.* xxi [3]; another monkey, MONTET, op. cit. pl. v [2]; men with cattle in inundation and fishermen, from sixth register, WILKINSON, *M. and C.* iii. 53 (No. 342), 2 Ser. i. 102 (No. 437, pt. 2) = ed. BIRCH, ii. 116 (No. 371), 429 (No. 480, pt. 2); WILKINSON MSS.* ii. 25 [middle, lower right], 26 A [16]; part, HAY*, 29850, 22-3; two fishermen, ROSELLINI, *Mon. Civ.* xxiv [3]; CAILLIAUD, op. cit. pl. 37 A [1]; some texts from third to sixth registers, CHAMPOLLION, *Not. Descr.* ii. 404-6.

(7)-(11) Six registers, deceased shooting with hunt in desert, procession of foreigners, fowling with net, and servants and men tending animals and bringing them to deceased, NEWBERRY and GRIFFITH, op. cit. i, pl. xxx, cf. p. 72; L. D. ii. 131, 132; HAY*, 29813, 40-1, 68-9; texts, CHAMPOLLION, *Not. Descr.* ii. 406-14. (7)-(10) Upper part, three registers, deceased followed by attendants hunting in desert, and procession of Amu headed by scribe; animals in desert and foreigners, MASPERO, *Les Peintures des tombeaux égyptiens* [&c.] in *Gazette Archéologique* (1879), 78 [upper], reprinted in *Bibliothèque Ég.* viii. 121 [upper]; some animals, two archers, and scribe and man leading oryx, HAY*, 29850, 29-38, 52-3, 56, 56*, 58-9, 61-7 (tracings); some animals, CHAMPOLLION, *Mon.* cccxciii bis [lower] (marked cccxiii), ccclxxvi [1], ccccxviii bis [bottom right], ccccxviii ter [bottom]; ROSELLINI, *Mon. Civ.* xxi [9, 10], xxii [1], xxiii [6]; wild cat, mythological animals, and Amu with gazelle and ibex, DAVIES, *The Work of the Graphic Branch of the Expedition in N. Y. Metro. Bull.* Pt. ii, April 1933, pp. 24, 25, 27, figs. 1, 4, 7; porcupine, WILKINSON, *M. and C.* iii. 19 (No. 328, 12) = ed. BIRCH, ii. 90 (No. 356, 12); mythological animal,

WILKINSON MSS.* ii. 23 B [near top right]; papyrus roll, with list of animals killed, held by scribe in second register, NEWBERRY and GRIFFITH, op. cit. i, pl. xxxviii [1], cf. p. 69 [bottom]; scribe and the Amu from third register, CHAMPOLLION, *Mon.* ccclxi [1, 2], ccclxii [3, 4], cccxciii bis [upper] (marked cccxciii); ROSELLINI, *Mon. Stor.* xxvi-xxvii [upper]; PRISSE, *L'Art Égyptien*, ii, *Peinture*, pl. 47 'Arrivée d'une famille asiatique en Égypte', cf. *Texte*, pp. 419-20; L. D. ii. 133; WILKINSON, *M. and C.* ii, pl. xiv opposite p. 296 = ed. BIRCH, i, pl. xii opposite p. 480; WILKINSON MSS.* ii. 26 [bottom]; omitting scribe, NEWBERRY and GRIFFITH, op. cit. i, pls. xxviii, xxxi; the Amu, MEYER, *Darstellungen der Fremdvölker*, 46-9; WRZESINSKI, *Atlas*, ii. 6; heads of two Amu men and two women, MASPERO, *Hist. Anc. des Peuples de l'Orient, Les Premières Mées*, figs. on pp. 16, 17; the scribe, and man with ibex, VILLIERS STUART, *Funeral Tent of an Egyptian Queen*, pl. 3 opposite p. 138; man with ibex, BRUGSCH, *Geogr. Inschr.* ii, pl. ii [5]; hieratic text presented by scribe, L. D. *Text*, ii, p. 88 [bottom]; NEWBERRY and GRIFFITH, op. cit. i, pl. xxxviii [2]; men with cranes, WILKINSON MSS.* x. 19, 27-8; id. 'Egyptian drawings', No. 118 (in the possession of Seymour de Ricci in Paris), see DE RICCI, *An Album of Drawings by Sir J. G. Wilkinson in Studies Presented to F. Ll. Griffith*, p. 475; man and dogs behind deceased shooting, *Descr. de l'Égypte, Ant.* iv, pl. 66 [3]; CHAMPOLLION, *Mon.* ccccxviii [middle]; ROSELLINI, *Mon. Civ.* xvii [5]; the dogs, WILKINSON, *M. and C.* iii. 32 (No. 331, 6, 7) = ed. BIRCH, ii. 99 (No. 359, 6, 7); man with spear, and man leading dogs (omitted), HAY*, 29850, 39-41 (tracings); WILKINSON MSS.* ii. 28 [lower left b]; text above deceased, id. ib. v. 3 [middle right]. Lower part, top register, fowling with net, leading cattle, and servants, second register, tending animals, bulls fighting, and servants, third register, men driving rams, asses, goats, and cattle to scribes; fowling scene, and tending animals, and rams &c. below it, MASPERO, op. cit. in *Gazette Archéologique* (1879), 78 [lower], reprinted in *Bibliothèque Ég.* viii. 121 [lower]; fowling, CHAMPOLLION, *Mon.* ccclxxvii bis; ROSELLINI, *Mon. Civ.* vii; man with geese, WILKINSON MSS.* ii. 25 [middle, near bottom]; geese, CHAMPOLLION, *Mon.* cccliii [second row], cccliv [bottom right]; ROSELLINI, *Mon. Civ.* xi [3, 6], xiii [7, 9, 10]; tending geese, oryxes, goats, and oxen, from second register, WILKINSON, *M. and C.* 2 Ser. i. 139 (No. 444) = ed. BIRCH, ii. 452 (No. 487); WILKINSON MSS.* ii. 25 [middle, lower left], 25 verso [bottom right]; CHAMPOLLION, *Mon.* ccclix [1, 2], ccclx [1, 2]; ROSELLINI, *Mon. Civ.* xxxi [1-4]; tending oryxes, NEWBERRY and GRIFFITH, op. cit. i, pl. xxvii; omitting one man, BURTON MSS.* 25634, 56 verso [upper]; tending goats and oxen, CAILLIAUD, *Arts et Métiers*, pl. 21 A; two groups of bulls fighting, WILKINSON, *M. and C.* ii. 446 (No. 317), 445 (No. 316) = ed. BIRCH, ii. 77 (No. 345), 76 (No. 344) (called Thebes); WILKINSON MSS.* ii. 26 A [5]; first group, PRISSE, *L'Art Égyptien*, ii, *Peinture*, pl. 48 [upper] 'Scènes de la vie rurale'; second group, CHAMPOLLION, *Mon.* ccclx [3]; ROSELLINI, *Mon. Civ.* xxvi [2]; men bringing bulls, goats, asses, and rams, from third register, WILKINSON MSS.* ii. 26 A [10-12]; group of rams, CHAMPOLLION, *Mon.* ccclx [4]; ROSELLINI, *Mon. Civ.* xxix [4]. (11) Deceased followed by attendants with three dogs; sketch of deceased and dog in front of him, WILKINSON MSS.* x. 20; part of text above deceased, id. ib. v. 3 [bottom left]; two dogs behind deceased, CHAMPOLLION, *Mon.* ccccxviii [top right and middle right]; ROSELLINI, *Mon. Civ.* xvii [3, 6]; the bitch, WILKINSON, *M. and C.* iii. 32 (No. 331, 3) = ed. BIRCH, ii. 99 (No. 359, 3); WILKINSON MSS.* ii. 27 A [16 bottom]; NEWBERRY and GRIFFITH, op. cit. iv, pl. iv; later hieratic graffiti between dogs, CHAMPOLLION, *Not. Descr.* ii. 423-5; first graffito, L. D. vi. 22 [1]; NEWBERRY and GRIFFITH, op. cit. i, pl. xxxviii [3]; transcriptions, MASPERO, *Les Peintures des tombeaux égyptiens* [&c.] in *Gazette Archéologique* (1879), p. 83 note 1, reprinted in *Bibliothèque Ég.* viii, pp. 127-8 note 4.

(12) Deceased with wife and attendants fowling, birds and butterflies above papyrus-clump, with fish, hippopotamus, &c., below, and at bottom men fishing with net, NEWBERRY and GRIFFITH, op. cit. i, pl. xxxii; L. D. ii. 130 [left]; HAY*, 29813, 42 [left], 70 [left]; texts, CHAMPOLLION, *Not. Descr.* ii. 414-15; birds and butterflies, id. *Mon.* ccclii [top right], cccliv [just above bottom row, middle], ccclxiii bis [lower right, bottom]; ROSELLINI, *Mon. Civ.* viii [2, 5], xi [5], xiii [2], xiv [7, 8]; fishing-scene, id. ib. xxiv [1, 2]; fishes, id. ib. xxv [4, 6, 8, 9, 10]; one fish, DAVIES, op. cit. in *N. Y. Metro. Bull.* Pt. ii, April 1933, p. 24, fig. 2; hippopotamus, HAY*, 29850, 20-1 (tracing); name of female attendant, L. D. *Text*, ii, p. 88 [middle right].

(13) Doorway to shrine, and above it deceased with son and official trapping birds, NEWBERRY and GRIFFITH, op. cit. i, pl. xxxiii, cf. pp. 67, 72; L. D. ii. 130 [middle]; HAY*, 29813, 42 [right], 43 [left], 70 [right], 71 [left]; names of son and official, WILKINSON MSS.* v. 3 [middle left]; name of official, L. D. *Text*, ii, p. 88 [middle left]; titles of deceased from jambs, CHAMPOLLION, *Not. Descr.* ii. 416 [upper]; tree on right with birds, and other birds, NEWBERRY and GRIFFITH, op. cit. iv, frontispiece, pls. vi, vii, xii [1, 2]; birds, CHAMPOLLION, *Mon.* ccclii [bottom, right and left], cccliii (omitting three birds in middle), cccliv [top left]; ROSELLINI, *Mon. Civ.* viii [1, 3, 4, 6], xi [1, 4, 9], xiii [3, 4]; tree on left with birds, DAVIES, op. cit. cover, cf. p. 23; HAY*, 29850, 24, 27, 28 (tracings); decoration above scene (not in NEWBERRY and GRIFFITH), CHAMPOLLION, *Mon.* cccxxxvii bis [top left]; ROSELLINI, *Mon. Civ.* lxx [1].

(14) Deceased harpooning fish, birds above papyrus-swamp, with hippopotamus and fish below, and at bottom men in canoes, NEWBERRY and GRIFFITH, op. cit. i, pl. xxxiv, cf. p. 72; iv, pl. xiii [3, 4]; L. D. ii. 130 [right]; HAY*, 29813, 43 [right], 71 [right]; texts, CHAMPOLLION, *Not. Descr.* ii. 416 [lower]-417; deceased with harpoon, ROSELLINI, *Mon. Civ.* xxv [1, 2]; fish below boat, id. ib. xxv [5, 7]; birds and animals, NEWBERRY and GRIFFITH, op. cit. iv, pls. v, viii-xi; CHAMPOLLION, *Mon.* cccl [top right], cccliii [second row from bottom, middle], cccliv [second row from top, and top right], ccclxiii bis [top, middle and right], cccxxxvii [middle], cccxxxviii ter [middle]; ROSELLINI, *Mon. Civ.* xi [2, 7, 8], xiii [1], xiv [1], xx [5], xxi [8]; two birds, *Descr. de l'Égypte, Ant.* iv, pl. 66 [15]; two fish harpooned and hippopotamus below, HAY*, 29850, 12-16 (tracings).

(15)-(16) Upper part, deceased before offerings with offering-list above, NEWBERRY and GRIFFITH, op. cit. i, pl. xxxv [upper left]; L. D. ii. 129 [upper]; HAY*, 29813, 44 [upper], 72-3 [upper]; texts, CHAMPOLLION, *Not. Descr.* ii. 387-9; offerings in front of deceased, ROSELLINI, *Mon. Civ.* lx [11], lxi [1, 2, 4]; CHAMPOLLION, *Mon.* ccclv [1], cccxxxiii [bottom], cccxxxix [top and middle right].

(17)-(19) Upper part, priests, offerings before wife seated with daughter behind her, and two registers sons and offering-bringers below, NEWBERRY and GRIFFITH, op. cit. i, pl. xxxv [upper right]; L. D. ii. 128 [upper]; HAY*, 29813, 45 [upper]; texts, CHAMPOLLION, *Not. Descr.* ii. 389-94; text above offerings, WILKINSON MSS.* v. 3 [top]; names of wife and last two attendants, L. D. *Text*, ii, p. 88 [top]; daughter, HAY*, 29850, 17-18 (tracings); man holding goose, and fowl lying beside braziers, id. ib. 70, 71, 73 (tracings).

(15)-(19) Lower part, two registers, offering-bringers with cattle, and butchers and servants with provisions, NEWBERRY and GRIFFITH, op. cit. i, pl. xxxv [lower], cf. p. 72 [near bottom]; L. D. ii. 129 [lower], 128 [lower]; HAY*, 29813, 44 [lower], 45 [lower] (with painted false doors in dado below scenes), 72-3 [lower]; texts, CHAMPOLLION, *Not. Descr.* ii. 395-8; top register, second group of men with animals and man carrying fowls in cages, PRISSE, *L'Art Égyptien*, ii, *Peinture*, pls. 48 [lower] 'Scènes de la vie rurale', 49 'Retour du chasseur en barque'; man with gazelle, and man with porcupine

and hare in cages, WILKINSON, *M. and C.* iii. 14 (No. 323) = ed. BIRCH, ii. 86 (No. 351); first group of servants with provisions from second register, CHAMPOLLION, *Mon.* cccxxxvi [top right]; ROSELLINI, *Mon. Civ.* lxxxviii [3].

(20) Five registers, dyers and carpenters, potters, men felling trees and deceased in palanquin watching boat-building, voyage to Abydos, bakers and weavers, and sculptors, NEWBERRY and GRIFFITH, op. cit. i, pl. xxix [left]; L. *D.* ii. 126; HAY*, 29813, 38 [left], 66; texts, CHAMPOLLION, *Not. Descr.* ii. 399-402; men felling trees and deceased in palanquin watching boat-building from second register, CHAMPOLLION, *Mon.* ccclv [2], ccclvi [1, 2]; ROSELLINI, *Mon. Civ.* xliii [1], xliv [1], xciii [2]; deceased in palanquin, WILKINSON, *M. and C.* ii. 208 (No. 174) = ed. BIRCH, i. 421 (No. 199); WILKINSON MSS.* ii. 26 A [15 lower]; third register, voyage to Abydos, CHAMPOLLION, *Mon.* ccclxxvii quat.; ROSELLINI, *Mon. Civ.* cix [1, 2]; DUEMICHEN, *Flotte*, xxviii [7, 8]; baking scene with overseers from fourth register, HAY*, 29850, 1-11 (tracings); woman kneading, CHAMPOLLION, *Mon.* ccclvii [1]; ROSELLINI, *Mon. Civ.* lxvii [7]; female weavers and spinners, WILKINSON, *M. and C.* ii. 60 (No. 91, 1-6) = ed. BIRCH, i. 317 (No. 110, 1-6); WILKINSON MSS.* ii. 26 A [4]; part, DAVIES, op. cit. in *N. Y. Metro. Bull.* Pt. ii, April 1933, p. 25, fig. 3; weavers, CAILLIAUD, *Arts et Métiers*, pl. 17A [10]; CHAMPOLLION, *Mon.* ccclxxxi bis [4]; ROSELLINI, *Mon. Civ.* xli [6]; LING ROTH, *Ancient Egyptian and Greek Looms*, p. 6, fig. 6 (from drawing by N. DE G. DAVIES); girl spinning, NEWBERRY and GRIFFITH, op. cit. iv, pl. xv.

(21) Above door, two registers, female acrobats and men dragging statue in shrine, and deceased (watching carpenters of 20) with scribes and servants behind him, id. ib. i, pl. xxix [middle]; L. *D.* ii. 126 [top right], 127 [top left]; HAY*, 29813, 38 [right]-39 [left], 66 [right]-67 [left]; texts, CHAMPOLLION, *Not. Descr.* ii. 402-4 [top]; female acrobats from upper register, ROSELLINI, *Mon. Civ.* ci [3]; WILKINSON MSS.* ii. 29 A verso [bottom right]; three acrobats, id. *M. and C.* ii. 416 (No. 291, fig. 1) = ed. BIRCH, ii. 54 (No. 316, fig. 1).

Dado of the four walls. Biographical text, NEWBERRY and GRIFFITH, op. cit. i, pls. xxv-xxvi, cf. pp. 56-66; L. *D.* ii. 124-5; BURTON, *Excerpta Hiero.* xxxiii-xxxiv; MASPERO, *La grande inscription de Béni-Hassan* in *Rec. de Trav.* i. 161-9, reprinted in *Bibliothèque Ég.* viii. 150-161; ll. 1-96, BRUGSCH, *Monumens*, xvi, xvii [1]; id. *Thes.* 1513-1525; REINISCH, *Aegyptische Chrestomathie*, pls. 1-4; HAY*, 29813, 83-83 verso, 29847, 59-62; parts, WILKINSON MSS.* v. 1-2 [upper]; l. 113 to end, CHAMPOLLION, *Not. Descr.* ii. 418-22; ll. 4-12, MASPERO, op. cit. in *Bibliothèque Ég.* viii. 119-20 note 2; ll. 89-96, the festivals, BRUGSCH, *Thes.* 231 [A]; the cartouches, ROSELLINI, *Mon. Stor. Text*, i, plate opposite p. 150 [bottom]; LETRONNE, *Table d'Abydos imprimée en caractères mobiles* in *Journal des Savants*, April 1845, opposite p. 256, reprinted in *Rev. Arch.* (1845), pl. 30; CULLIMORE in *Trans. Roy. Soc. Lit.* ii (1832), plate 'Chronologia Hieroglyphica' at end [top right]; FELIX (translated by TORRI), *Note sopra le dinastie de' Faraoni*, pl. iv. Positions on walls: ll. 1-28 at (12), ll. 28-96 at (7)-(11), ll. 96-120 at (6), ll. 121-144 at (20), ll. 145-198 at (15)-(19), ll. 199-222 at (14).

Pillars.

(22)-(23), (24)-(25) Architraves. Texts, NEWBERRY and GRIFFITH, op. cit. i, pl. xxiv [lower], cf. pp. 55-6; L. *D.* ii. 123 g, h; HAY*, 29847, 62 verso [upper].

Shrine.

(26) Figure of woman seal-bearer(?), NEWBERRY and GRIFFITH, op. cit. i, pl. xxxvi [left].

(27)-(28) Offering-list and offerings, two daughters and wife of deceased, with decoration of painted false doors below, id. ib. i, pl. xxxvi [right]; cf. iv, pl. xxi [right]; frieze-text, L. *D. Text*, ii, p. 90 [top].

(29) and (30) Female relations (effaced) on either side of broken statue of deceased, see NEWBERRY and GRIFFITH, *op. cit.* i, p. 71-2.

(31)-(32) Deceased (?) and sons, &c., before altar, with decoration of painted false doors below, *id. ib.* i, pl. xxxvii; cf. iv, pl. xxi [right]; names of a son, two officials, and a lector, *L. D. Text*, ii, p. 89 [middle].

4. KHNEḤHOTP IV $\text{Ⲭ} \frac{\text{ⲁ}}{\text{ⲟ}} \text{ⲛ}$, Hereditary Prince. Dyn. XII. (3 of LEPSIUS; 5 of CHAMPOLLION.)

Plan, sections, and view, NEWBERRY and GRIFFITH, *Beni Hasan*, i, pls. xxxix, xl; plan, *L. D.* i. 58 [3].

Entrance.

Lintel; names of deceased and mother, NEWBERRY and GRIFFITH, *op. cit.* i, p. 7; CHAMPOLLION, *Not. Descr.* ii. 427 [bottom (1)], 459 [top]; WILKINSON MSS.* i. 81 [right middle].

13. KHNEḤHOTP II $\text{Ⲭ} \frac{\text{ⲁ}}{\text{ⲟ}} \text{ⲛ}$, Scribe of the royal archives; Regulator of a guild in the Temple of Pa'kht; &c. Dyn. X or XI. (4 of LEPSIUS; 6 of CHAMPOLLION.) (See plan, *supra* p. 140.)

See NEWBERRY and GRIFFITH, *op. cit.* i, pp. 73-7, cf. ii, p. 5; CHAMPOLLION, *op. cit.* ii. 459 [6]. Plan, section, and elevation, GRIFFITH and NEWBERRY, *op. cit.* i, pl. xli [right]; plan, *L. D.* i. 58 [4].

Entrance.

(1)-(3) Lintel and jambs, NEWBERRY and GRIFFITH, *op. cit.* i, pl. xli [left, a-c], cf. pp. 76-7; texts, CHAMPOLLION, *Not. Descr.* ii. 435-6 [upper]; *L. D.* ii. 142 c, a, and *Text*, ii, p. 91 [top, left and right].

(4) and (5) Thicknesses; texts, NEWBERRY and GRIFFITH, *op. cit.* i, pl. xli [left, d, e], cf. p. 77; CHAMPOLLION, *Not. Descr.* ii. 436 [lower]; *L. D.* ii. 142 b, and *Text*, ii, p. 91 [middle].

14. KHNEḤHOTP I $\text{Ⲭ} \frac{\text{ⲁ}}{\text{ⲟ}} \text{ⲛ}$, Nomarch of the Oryx-nome; Mayor of Menat-Khufu; &c. Temp. Amenemḥet I. (5 of LEPSIUS.) (See plan, *supra* p. 140.)

NEWBERRY and GRIFFITH, *Beni Hasan*, i, pls. xlv-xlvii, pp. 79-85. Plan, sections, and view, *id. ib.* pls. xlii, xliii; plan, *L. D.* i. 58 [5].

Hall.

(1) Upper part, deceased seated before destroyed scene, lower part, painted false door, see NEWBERRY and GRIFFITH, *op. cit.* i, p. 84.

(2)-(3) Six registers, hunting, remains of scene of wine-making, men bringing fish and fowl, with *sm*-priest and others, netting fowl in papyrus-clump, trades (?) before scribe, and harvest, in front of deceased and wife, *id. ib.* pl. xlvi (incomplete).

(4) Pilaster. Four registers, four male attendants, two female attendants, two chests, *id. ib.* pl. xlvi [right].

(5) Top register, hunting game in desert, with destroyed marsh-scene below; text at top, *id. ib.* p. 85 [top].

(6)-(10) Top to third registers (north end destroyed), wrestlers; text at top, *id. ib.* p. 85 [middle].

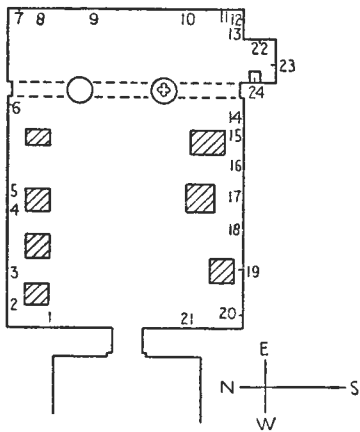

Tomb 15. Bağt III. From NEWBERRY and GRIFFITH, *Beni Hasan*, ii, pl. ii.

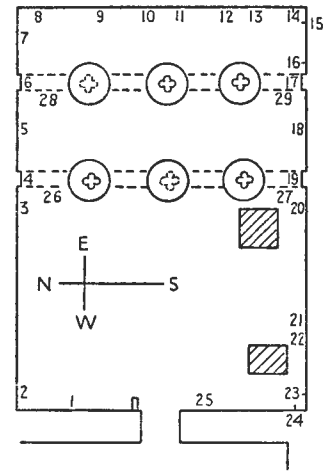

Tomb 17. Khety. From NEWBERRY and GRIFFITH, *Beni Hasan*, ii, pl. ix.

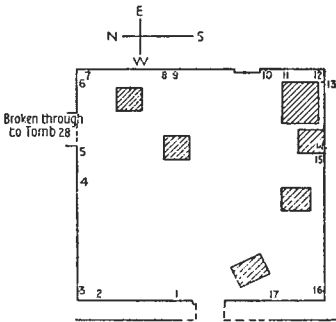

Tomb 29. Bağt I. From NEWBERRY and GRIFFITH, *Beni Hasan*, ii, pl. xxvii.

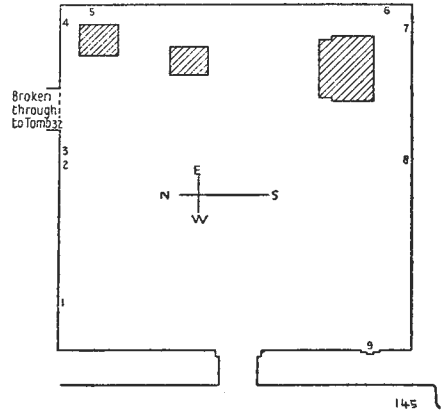

Tomb 33. Bağt II. From NEWBERRY and GRIFFITH, *Beni Hasan*, ii, pl. xxxiv.

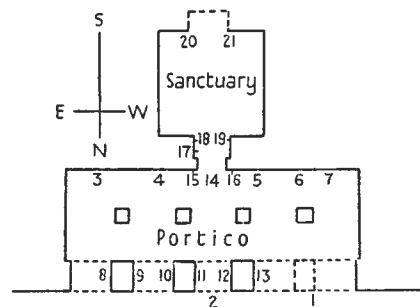

İŞTABL 'ANTAR (SPEOS ARTEMIDOS).
GREAT SPEOS.

From *L. D. Text*, ii, p. 108.

(6)–(8) Fourth register, archers attacking fortress, archer and four Berbers, two Nubian archers, four Egyptians, fifth register, seven soldiers attacking fortress, archer, three soldiers with battering-ram behind screen, followed by seven archers, sixth register, soldiers, some fighting with each other; two Nubian archers dancing and stringing bow, and four soldiers with axes, from sixth register, id. ib. i, pl. xlvi [top, two groups on right].

(9)–(10) Fourth register, Egyptian, five Libyans (?) including two women with babies, goats, and two Libyan women captives with babies led by Egyptians; omitting first Egyptian, id. ib. pls. xlvi [middle]; the Libyans, BATES, *The Eastern Libyans*, pl. v [1, 2, 3]; one man and one woman, MÖLLER, *Die Aegypter und ihre libyschen Nachbarn in Zeitschr. d. Deutsch. Morgenl. Gesell.* Neue Folge. vol. 3, pl. 4; woman with baby, DAVIES, *The Work of the Graphic Branch of the Expedition in N.Y. Metro. Bull.* Pt. ii, Dec. 1930, p. 40, fig. 9. Fifth register, four soldiers, man tying up clothes of slain foes, and two soldiers, NEWBERRY and GRIFFITH, op. cit. i, pl. xlvi [bottom]. Sixth register, soldiers, four Berbers, and one Egyptian archer; the Berbers, MEYER, *Darstellungen der Fremdvölker*, 50–1; WRESZINSKI, *Atlas*, ii. 8; three Berbers and archer, NEWBERRY and GRIFFITH, op. cit. i, pl. xlvi [top left].

(11), (12), (13) Deceased before destroyed scene, pilaster with two registers of two attendants, and deceased before unfinished scene; title of deceased, id. ib. p. 85 [bottom].

(14) Upper part, historical inscription with cartouches of Amenemhet I (almost invisible now), lower part, boats in marshes before deceased and daughters (much destroyed scene); historical inscription, id. ib. pl. xliv.

15. BAKT III , Nomarch of the Oryx-nome; Chancellor of the King of Lower Egypt; &c. Dyn. XI. (6 of LEPSIUS; 2 of CHAMPOLLION.)

Complete, NEWBERRY and GRIFFITH, *Beni Hasan*, ii, pls. iv–viii A, pp. 41–50 (omitting west wall and shrine). Plans, sections, and elevations, id. ib. pls. ii, iii; plan, L. D. i. 58 [6]; rough plan, CHAMPOLLION, *Not. Descr.* ii. 359, cf. 457–8 [2].

Hall.

(1) Scene in marshes with men in boats gathering papyrus, man harpooning crocodiles, &c. (unfinished), see id. ib. ii. 359; text below frieze, NEWBERRY and GRIFFITH, op. cit. ii, p. 46 [top].

(2)–(6) Top and second registers, hunting and netting game in desert, and linen-making, &c., third to sixth registers, deceased and wife watching weavers and acrobats, counting of cattle, industries, and fishing, id. ib. ii, pl. iv, cf. p. 46; texts, L. D. *Text*, ii, pp. 96–9 [top]; texts and details, MONTET, op. cit. in *Bull. Inst. Fr. Arch. Or.* ix, pp. 5–7, pls. vii [1, 3], viii [1–3], x [3–9], xi [12, 13]; omitting text of wife, CHAMPOLLION, *Not. Descr.* ii. 360–7; texts of deceased and wife, L. D. ii. 142 f, g. Top register (as far as ostrich), WILKINSON MSS.* ii. 28 [upper right]; animals and two hunters, CHAMPOLLION, *Mon.* ccclxiii bis [bottom middle], ccclxxxii, ccclxxxiii, ccclxxxiv, ccccxxvi [1], ccccxxvii [sides, and top middle], ccccxxviii bis [top, and middle right and left], ccccxxviii quat; ROSELLINI, *Mon. Civ.* xiv [3], xvi [1], xix, xx [1–4, 6, 7, 9], xxiii [1–3, 5]; animals and three hunters, WILKINSON, *M. and C.* iii. 15 (No. 325), 16 (No. 326), 18 (No. 327), 19 (No. 328, 9–11, 13, 14, 16, 17), 23 (No. 330, 2–4) = ed. BIRCH, ii. 87 (No. 353), 88 (No. 354), 89 (No. 355), 90 (No. 356, 9–11, 13, 14, 16, 17), 93 (No. 358, 2–4), iii. 310 (No. 572), 311 (Nos. 575, 577); some of the animals, WILKINSON MSS.* ii. 28 verso [middle right, and bottom, middle and left]; four mythological animals behind second hunter, DAVIES, op. cit. in *N.Y. Metro. Bull.* Pt. ii, April 1933, p. 27,

fig. 8; two animals, WILKINSON MSS.* ii. 23 B [top right]. Second register, barbers, linen-makers, male spinners and twine-makers, painters and sculptors; barbers and spinners, id. ib. 23 A verso [middle lower], 25 verso [top], 26 verso [fourth row, middle right], 26 A [14], x. 21 [top], 22 [middle], cf. xii. 19 [lower right]; two groups of linen-makers, CHAMPOLLION, *Mon.* ccclxxxvi [2, 3]; ROSELLINI, *Mon. Civ.* xlii [3], lxv [9]; man with spindle (inaccurate), WILKINSON, *M. and C.* ii. 60 (No. 91, 7) = ed. BIRCH, i. 317 (No. 110, 7); group with men quarrelling between twine-makers and painters, ROSELLINI, *Mon. Civ.* civ [2]; two groups of sculptors, CHAMPOLLION, *Mon.* ccclxxxvi [5]; ROSELLINI, *Mon. Civ.* xlvi [6, 7]; sculptor and statue, BURTON MSS.* 25634, 58 [top]. Third register, female spinners, weavers, and acrobats (omitting last group), WILKINSON MSS.* ii. 26 [middle], 29 A verso [middle]; spinners and weavers, CHAMPOLLION, *Mon.* ccclxxxvi [4], ccclxxxvii [1]; ROSELLINI, *Mon. Civ.* xli [3], xlii [4]; two female spinners, WILKINSON, *M. and C.* ii. 60 (No. 91, 8, 9) = ed. BIRCH, i. 317 (No. 110, 8, 9); girl acrobats and ball-players (incomplete), ROSELLINI, *Mon. Civ.* ci [1 (omitting first figure), 2]; CHAMPOLLION, *Mon.* ccclxxxvii [2, 3]; WILKINSON, *M. and C.* ii. 416 (No. 291, 2, 3),¹ 429 (Nos. 302, 302 a, 2-4), 430 (No. 303, 1-5), 433 (No. 305) = ed. BIRCH, ii. 54 (No. 316, 2, 3),¹ 65 (Nos. 329, 330, 2, 3, 4), 66 (No. 331, 1-5), 68 (No. 333); last group and a girl, HAMILTON, *Aegyptiaca*, xxi [9] (inaccurate), xxii [4, right]; two groups, MONTET, op. cit. pl. ix; one group playing ball, NEWBERRY and GRIFFITH, op. cit. ii, pl. viii A. Fourth register, bringing cattle and goats, knife- and sandal-makers, scribe, defaulters, and men with goats, ROSELLINI, *Mon. Civ.* cxxiv [1, third row]; knife- and sandal-makers, id. ib. lxiv [5]; CHAMPOLLION, *Mon.* ccclxxxvii [4, 5]; WILKINSON MSS.* ii. 27 [top]; knife-makers, NEWBERRY and GRIFFITH, op. cit. iii, pl. vii, cf. p. 34. Fifth register, men leading animals, female musicians, goldsmiths, painters and sculptor; goldsmiths and painters, WILKINSON MSS.* ii. 27 [bottom and middle]; goldsmiths, ROSELLINI, *Mon. Civ.* li [4]; CHAMPOLLION, *Mon.* ccclxxxvii [6], ccclxxxviii [1-3]; omitting overseer and chests, WILKINSON, *M. and C.* iii. 222 (No. 374) = ed. BIRCH, ii. 234 (No. 413); two goldsmiths, men with scales, and chest behind them, BURTON MSS.* 25634, 58 [middle and bottom]; three groups, painters and sculptor, ROSELLINI, *Mon. Civ.* xlvi [3, 10, 11], xlix [2]; painters, WILKINSON, op. cit. iii. 311 (No. 385) = ed. BIRCH, ii. 294 (No. 424); second painter and sculptor, WILKINSON MSS.* ii. 27 A [17 lower]; men painting on board, CHAMPOLLION, *Mon.* ccclxxxviii [4]. Sixth register, fishing with net, boatmen quarrelling, deceased and wife fowling in papyrus-clump, and birds; birds with names, and bats, WILKINSON MSS.* ii. 27 verso [lower], 28 [lower right], 29 [top and middle left], 29 A verso [middle right], 30 [upper right, and lower]; bats, ROSELLINI, *Mon. Civ.* xiv [4-6]; CHAMPOLLION, *Mon.* ccclxx [2], ccclxiii bis [middle]; WILKINSON, *M. and C.* iii. 50 (No. 340, 18-20) = ed. BIRCH, ii. 113 (No. 369, 18-20); birds with names, ROSELLINI, *Mon. Civ.* ix [1-13], x [1-12]; CHAMPOLLION, *Mon.* cccl [omitting top right], cccli, cccli [second row from bottom]; WILKINSON, *M. and C.* iii. 48 (No. 339, 3-17), 50 (No. 340, 1-14) = ed. BIRCH, ii. 112 (No. 368, 3-17), 113 (No. 369, 1-14); three birds, WILKINSON MSS.* ii. 23 B [bottom left]; two birds, NEWBERRY and GRIFFITH, op. cit. iv, pl. xiii [1-2]; one bird with name, L. D. *Text*, ii, p. 98 [lower]; second group of boatmen fighting, with hippopotamus below, WILKINSON MSS.* ii. 24 [bottom]. Frieze; text, L. D. ii. 142 d, and *Text*, ii, p. 99.

(7)-(11) Top to sixth registers, wrestling, seventh to ninth registers, attack on fortress by Egyptian and foreign soldiers (the fifth to ninth registers are blank at 11), NEWBERRY and GRIFFITH op. cit. ii, pl. v; four pairs of wrestlers (probably from here), *Descr. de l'Égypte*, *Ant.* iv, pl. 66 [1 lower]; CAILLIAUD, *Arts et Métiers*, pl. 39 [bottom]; pair of

¹ The text above the figures is taken from a similar group in the tomb of Khety, see *infra* p. 155.

wrestlers from top register, CHAMPOLLION, *Mon.* ccclxiv [1]; ROSELLINI, *Mon. Civ.* cxi [1]; WILKINSON, *M. and C.* ii. 438 (No. 310, 11, 12) = ed. BIRCH, ii. 71 (No. 338, 11, 12); pair of wrestlers from third register, NEWBERRY and GRIFFITH, op. cit. ii, pl. viii; first, second, and sixth light-skinned soldiers, and Nubian stringing bow from seventh register, CHAMPOLLION, *Mon.* ccclxxxviii [5]; ROSELLINI, *Mon. Civ.* cxvii [1, 3]; CAILLIAUD, op. cit. pl. 43 B [2, 1 (1st figure)]; second and third light-skinned soldiers, MEYER, *Darstellungen der Fremdvölker*, 261; WRZESINSKI, *Atlas*, ii. 10; kneeling archer, men with battering-ram, three dancing Nubians, and man stringing bow, from eighth register, CHAMPOLLION, *Mon.* ccclxiv [2, 3]; ROSELLINI, *Mon. Civ.* cxvii [2], cxviii [1]; CAILLIAUD, op. cit. pls. 43 A [1], 43 B [1, second to fifth figures]; three dancing Nubians, MEYER, op. cit. 52; three groups of soldiers with sticks, and first three foreign soldiers, WILKINSON MSS.* xii. 20 [top]-21 [top], 20 [middle].

(12)-(13) Upper part, top register, men sealing jars, pouring wine into jars, and wine-press (not in NEWBERRY and GRIFFITH), second register, stirring, straining, and pressing wine, tree with birds, and trap; second register, NEWBERRY and GRIFFITH, op. cit. ii, pl. vi [top]; WILKINSON MSS.* ii. 29 A verso [bottom left and middle, and lower middle left], cf. 23 B [middle lower], 27 A [17 upper]; HAY*, 29850, 95-107 (tracings); wine-making and wine-press, CHAMPOLLION, *Mon.* ccclxxxix [3, 4]; ROSELLINI, *Mon. Civ.* xxxviii [3]; wine-press, CAILLIAUD, op. cit. pl. 5 A [4, 5]; WILKINSON, *M. and C.* ii. 153 (No. 140) = ed. BIRCH, i. 383 (No. 160); birds and tree, WILKINSON MSS.* xii. 21 [middle]; man and bird-trap, ROSELLINI, *Mon. Civ.* vi [2]; WILKINSON, *M. and C.* iii. 38 (No. 334, 4) = ed. BIRCH, ii. 103 (No. 362, 4); texts, MONTET, op. cit. pp. 8-9 with figs. 6-11; of second register, CHAMPOLLION, *Not. Descr.* ii. 368.

(12) Lower part, five registers animals, bakers, and men bringing food, NEWBERRY and GRIFFITH, op. cit. ii, pl. vi [lower left] (reversing fourth and fifth registers); texts, CHAMPOLLION, *Not. Descr.* ii. 381-3; L. D. *Text*, ii, p. 95; texts and details, MONTET, op. cit. p. 10, and pls. xi [1-6], xii [3-5]; top to third registers, WILKINSON MSS.* ii. 26 verso [top right, and second row]; top register, man with cat, mouse, two monkeys with baby, and two baboons, HAY*, 29850, 87-91, 93 (tracings); omitting seated baboon, ROSELLINI, *Mon. Civ.* xxi [2, 4-7]; some of the animals, BURTON MSS.* 25634, 56 [upper]; CHAMPOLLION, *Mon.* cccxxviii ter [top left, middle right and left], cccxciv [2]; cat and mouse, WILKINSON, *M. and C.* iii. 19 (No. 328, 18, 19) = ed. BIRCH, ii. 90 (No. 356, 18, 19); WILKINSON MSS.* ii. 28 verso [bottom right]; second register, men pounding meal, and women making bread, CHAMPOLLION, *Mon.* cccxciv [3, 4]; ROSELLINI, *Mon. Civ.* lxvii [3-6]; omitting last figure, WILKINSON MSS.* ii. 27 A [12 bottom]; third register, two men and two women making bread, ROSELLINI, *Mon. Civ.* lxvii [1, 2]; the women, BURTON MSS.* 25634, 56 [lower]; one water-carrier from fourth register, ROSELLINI, *Mon. Civ.* lxxxvii [3].

(14)-(20) Deceased watching funeral procession, stock-taking, and men bringing animals, playing games, and netting fowl, &c., between two smaller figures of deceased, and industries, NEWBERRY and GRIFFITH, op. cit. ii, pl. vii; texts (omitting those of large figure of deceased), L. D. *Text*, ii, pp. 92-4 [bottom]; omitting those of the three figures of deceased, CHAMPOLLION, *Not. Descr.* ii. 369-81; texts and details, MONTET, op. cit. pp. 10-14 and pls. xiii, xiv [1-7]; some texts from scenes of industries, BISSING, *A propos de Beni-Hassan*, ii, plate xvi in *Ann. Serv.* v. 112. (15)-(20) Top register, funeral procession with dancers, second and third registers, stock-taking; dragging statue in shrine and bringing funerary outfit from top register, CHAMPOLLION, *Mon.* ccclxxxix [1], cccxc [1]; ROSELLINI, *Mon. Civ.* xciii [1], lxxxvii [1-11]; second register, HAY*, 29850, 142-77 (tracings); scribes, man beaten, defaulters, men with bull, CHAMPOLLION, *Mon.* cccxc [3, 4],

cccxcī [1, 2]; ROSELLINI, *Mon. Civ.* cxxiii [A, B, C]; omitting scribes, WILKINSON MSS.* ii. 26 verso [third row, fourth row left], 23 A [lower right], 27 A [2 top and upper middle]; punishment of defaulters, WILKINSON, *M. and C.* ii. 41 (No. 87) = ed. BIRCH, i. 305 (No. 106); man beaten, *Descr. de l'Égypte, Ant.* iv, pl. 66 [10]; CAILLIAUD, *Arts et Métiers*, pl. 39 [top]; man leading ox, and boy and calf drinking from cow, DAVIES, op. cit. in *N. Y. Metro. Bull.* Pt. ii, April 1933, pp. 28, 29, figs. 9, 10; boy and calf drinking from cow, CHAMPOLLION, *Mon.* cccxc [2]; ROSELLINI, *Mon. Civ.* xxvii [3]; third register, HAY*, 29850, 108-41, 178-9 (tracings); scribes, women and men defaulters, asses, ROSELLINI, *Mon. Civ.* cxxiv [1 upper and middle], xxx [2]; CHAMPOLLION, *Mon.* cccxcī [5, 6], cccxcii [1-3]; woman beaten, WILKINSON, *M. and C.* ii. 42 (No. 88) = ed. BIRCH, i. 305 (No. 107); WILKINSON MSS.* ii. 26 verso [fourth row, middle left]; two asses and foal, id. ib. ii. 27 A [18 lower]; oxen fighting, CHAMPOLLION, *Mon.* cccxcī [3]; ROSELLINI, *Mon. Civ.* xxvi [3]; WILKINSON, *M. and C.* ii. 443 (No. 314) = ed. BIRCH, ii. 75 (No. 342); WILKINSON MSS.* ii. 23 A verso [left lower], 27 A [18 upper]. (15)-(16) Fourth to sixth registers, potters and metal-workers, id. ib. 25 [bottom, left and middle], 26 [top], 26 verso [top left]; fourth and fifth registers, potters (omitting last group in fifth register), CHAMPOLLION, *Mon.* cccxcii [4, 5], cccxciii [1, 2, 3]; ROSELLINI, *Mon. Civ.* 1 [1 a-d]; omitting first man, CAILLIAUD, op. cit. pl. 16 [1-14]; part, WILKINSON, *M. and C.* iii. 164 (No. 363) = ed. BIRCH, ii. 192 (No. 397); men with scales and men with blow-pipe from sixth register, WILKINSON MSS.* ii. 27 A [2 lower middle and bottom]; men with blow-pipe, id. *M. and C.* iii. 89 (No. 349, pt. i) = ed. BIRCH, ii. 140 (No. 380, pt. i); PRISSE, *L'Art Égyptien, Texte*, 314. (17)-(20) Fourth to seventh registers, bringing animals and fowl, games, fowling and fishing, and draughts-players, &c., with figure of deceased on each side; fourth register, men (one in striped garment) bringing cow and calves, and games before deceased, ROSELLINI, *Mon. Civ.* xxvii [6], civ [1]; WILKINSON MSS.* ii. 29 B verso [bottom and middle upper right]; men with cow and calves, CHAMPOLLION, *Mon.* cccxciii [4]; HAY*, 29850, 81-86 (tracings); games, WILKINSON, *M. and C.* ii. 434 (No. 307), 435 (No. 308), 439 (No. 312) = ed. BIRCH, ii. 69 (No. 335), 70 (No. 336), 73 (No. 340), (two last from ROSELLINI); fowling with net from sixth register, CHAMPOLLION, *Mon.* cccxciv [1]; ROSELLINI, *Mon. Civ.* iv [lower]; draughts-players, &c., from sixth register, WILKINSON MSS.* ii. 29 A verso [top]; text of deceased on right, L. D. ii. 142 e.

(21) (Unfinished.) Top register, offerings brought to deceased, second register (incomplete), goats browsing in desert and two boats, third register, granary and harvest, fourth register, flax-harvest, fifth register, men bringing bulls, and offering-bringers (?) before deceased. Text below frieze, NEWBERRY and GRIFFITH, op. cit. ii, p. 45 [bottom].

Shrine.

(22) Six registers, vases, offerings, butchers, making bread and preparing offerings, see CHAMPOLLION, *Not. Descr.* ii. 368.

(23) Offerings and altar before deceased, with offering-list above, see id. ib. 368.

(24) Remains of small altar, see id. ib. 368; NEWBERRY and GRIFFITH, op. cit. ii, p. 50.

17. KHETY , Nomarch of the Oryx-nome; Commander of troops in all difficult places; &c. Dyn. XI. (7 of LEPSIUS; 1 of CHAMPOLLION.) (See plan, supra p. 150.)

Complete, NEWBERRY and GRIFFITH, *Beni Hassan*, ii, pp. 51-62, pls. x-xix. Plan, section, and elevations, id. ib. pl. ix; plan, *Descr. de l'Égypte, Ant.* iv, pl. 64 [8]; CHAMPOLLION, *Not. Descr.* ii. 334; L. D. i. 60 [right], cf. 58 [7]; HAY*, 29847, 10.

Elevation and details of column, NEWBERRY and GRIFFITH, op. cit. pl. x; ROSELLINI, *Mon. Civ.* ii [1-3]; column, L. D. i. 60 [middle].

Hall.

View, STEINDORFF, *Die Kunst der Ägypter*, 118; HOSKINS MSS.* i. 88.

(1) Top register, deceased harpooning fish, with pigs, crocodiles, hippopotami, &c., in papyrus-swamps, second register, deceased with club, and marsh-scene, third register, deceased seated with back to men netting fowl, &c., and men in canoes among papyrus, NEWBERRY and GRIFFITH, op. cit. ii, pl. xi; sketch shewing three hippopotami on hill, fish harpooned, and hippopotamus and calf, WILKINSON MSS.* xii. 21 [bottom], ii. 27 A [20]; pigs, DAVIES, op. cit. in *N. Y. Metro. Bull.* Pt. ii, April 1933, p. 27, fig. 6 [A]; see CHAMPOLLION, *Not. Descr.* ii. 338.

(2)-(3) Six registers hunting, barbers and male linen-makers, female weavers and acrobats, offering-bringers and dancers before men dragging shrine with statues of deceased and wife, carpenters and spear-makers, and remains of fowling and fishing scene, NEWBERRY and GRIFFITH, op. cit. ii, pl. xiii, cf. p. 57; HAY*, 29813, 46-7, 76-7; texts, CHAMPOLLION, *Not. Descr.* ii. 339-44; texts and details, MONTET, op. cit. in *Bull. Inst. Fr. Arch. Or.* ix, pp. 15-16, and pls. vii [2], viii [4-6], xi [10, 11], xiv [8-11]; names of animals in hunting-scene, and texts of male dancers in fourth register, L. D. *Text*, ii, pp. 104 [middle]-105 [top]; some texts from lower registers, BISSING, *À propos de Beni-Hassan*, ii, plate xvi in *Ann. Serv.* v. 111-12; animals with names from top register, WILKINSON MSS.* ii. 26 verso [bottom], 29 A verso [upper middle left], 29 B verso [middle lower left]; second register, barbers, linen-makers, spinners, net-makers, and weavers, CHAMPOLLION, *Mon.* ccclxv [3-5], ccclxvi [1-3]; ROSELLINI, *Mon. Civ.* lxxvi [2], xli [1 upper, 4, 5], xlii [1, 2]; MINUTOLI, *Reise zum Tempel des Jupiter Ammon* [&c.], xxiv [1, 2]; barbers, CAILLIAUD, *Arts et Métiers*, pl. 21 B [4]; WILKINSON, *M. and C.* iii. 393 (No. 418) = ed. BIRCH, ii. 357 (No. 459); WILKINSON MSS.* ii. 23 B [middle top], 27 A [5 middle], x. 21 [middle and bottom]; BURTON MSS.* 25634, 45 verso [middle]; overseer and two men beating flax, WILKINSON MSS.* x. 22 [top]; spinners, net-makers, and weavers, CAILLIAUD, op. cit. pls. 17 A [7-9], 18 [1, 2]; omitting one spinner, WILKINSON MSS.* ii. 29 B verso [lower middle right]; omitting two spinners, id. *M. and C.* iii. 134 (No. 353) = ed. BIRCH, ii. 170 (No. 386); third register, female weavers and spinners, and girl acrobats, CHAMPOLLION, *Mon.* ccclxvi [4-5], ccclxvii [1-5]; ROSELLINI, *Mon. Civ.* xli [1 lower, 2], xlii [5], c [6-18], ci [1 left]; spinners and first group of weavers, CAILLIAUD, op. cit. pl. 17 A [1-6]; some acrobats and ball-players, id. *ib.* pl. 41; WILKINSON MSS.* ii. 27 A [3 upper and middle left]; two ball-players and one acrobat, id. *M. and C.* ii. 429 (No. 302 a, 1), 430 (No. 303, 6) = ed. BIRCH, ii. 65 (No. 330, 1), 66 (No. 331, 6); girl acrobats and male dancers from third and fourth registers, BURTON MSS.* 25634, 49, 49 verso [lower], 50 [upper], 52, 53; men bringing funerary outfit, from fourth register, CHAMPOLLION, *Mon.* ccclxviii [1-3]; ROSELLINI, *Mon. Civ.* lxxvi [3-12]; male and female dancers and clappers, WILKINSON MSS.* ii. 25 verso [middle]; six male dancers and two female clappers, id. *M. and C.* ii. 335 (No. 237) = ed. BIRCH, i. 505 (No. 262); two male dancers and two female clappers, ROSELLINI, *Mon. Civ.* xcix [3]; two male dancers, *Descr. de l'Égypte, Ant.* iv, pl. 66 [2]; one dancer, HAMILTON, *Aegyptiaca*, xxi [8]; fifth register, sculptors, painters, carpenters, draughts-players, cooks, and spear-makers, ROSELLINI, *Mon. Civ.* xliii [2], xlv [1, 2], xlvi [2, 4, 5], cxiii [bottom], cxliii [4], lxxv [10] (omitting last two men); omitting men cooking duck and last two men, CHAMPOLLION, *Mon.* ccclxiii [2], ccclxviii [4], ccclxix [1-4], ccclxx [1]; omitting spear-making, BURTON MSS.* 25634, 45 verso [top], 45; man with saw, two other carpenters, two groups draughts-players, and two spear-makers, WILKINSON MSS.* ii. 26 A [6 lower left],

27 A [4, 5 top]; three carpenters, and draughts-players, CAILLIAUD, *op. cit.* pls. 5 A [1-3], 41 A [1-4] (called Qurna); draughts-players, WILKINSON, *M. and C.* i. 44 (No. 3 a, b), ii. 419 (No. 294, 1) = ed. BIRCH, i. 32 (No. 2 a, b), ii. 57 (No. 319, 1); WILKINSON MSS.* ii. 26 A [6 upper]. Frieze, L. D. ii. 142 i, and *Text*, ii, p. 105 [bottom].

(4) Pilaster. One column of text, NEWBERRY and GRIFFITH, *op. cit.* ii, pl. xiv [left], cf. p. 58; CHAMPOLLION, *Not. Descr.* ii. 345 [upper]; L. D. ii. 143 a.

(5) Upper part, catching animals in desert, lower part, deceased and wife, with musicians above, and bird-traps behind, NEWBERRY and GRIFFITH, *op. cit.* ii, pl. xiv [middle left]; texts, CHAMPOLLION, *Not. Descr.* ii. 345 [lower]-346; omitting text in front of deceased, L. D. ii. 143 c, e, and *Text*, ii, p. 105 [middle]; desert-scene, HAY*, 29813, 50 [top], 78 [top]; men catching a gazelle, WILKINSON, *M. and C.* iii. 15 (No. 324) = ed. BIRCH, ii. 87 (No. 352); dogs in front of deceased, CHAMPOLLION, *Mon.* ccccxvi [6], ccccxviii [top left, middle left]; ROSELLINI, *Mon. Civ.* xvi [6], xvii [1, 4]; middle and bottom dogs, HAY*, 29850, 194-5 (tracings); top dog, WILKINSON, *op. cit.* iii. 32 (No. 331, 5) = ed. BIRCH, ii. 99 (No. 359, 5); middle dog, NEWBERRY and GRIFFITH, *op. cit.* iv, pl. iii; musicians, HAY*, 29813, 50 [middle upper], 78 [middle upper]; bird-traps, HAY*, 29850, 190-2 (tracings); lower bird-trap, WILKINSON, *M. and C.* iii. 38 (No. 334, 2) = ed. BIRCH, ii. 103 (No. 362, 2); WILKINSON MSS.* ii. 27 A [1 lower right]. Frieze; text, L. D. ii. 142 h, and *Text*, ii, p. 105 [top].

(6) Pilaster. Column of text, NEWBERRY and GRIFFITH, *op. cit.* ii, pl. xiv [middle right], cf. p. 59; CHAMPOLLION, *Not. Descr.* ii. 347 [B]; L. D. ii. 143 b.

(7) Seven registers men carrying baskets of produce, metal-workers, men bringing gazelles, oryxes, geese, and cranes, and tree and bird-traps, NEWBERRY and GRIFFITH, *op. cit.* ii, pl. xiv [right]; text above top register, CHAMPOLLION, *Not. Descr.* ii. 346 [bottom]; two men and samples of the produce from top and second registers, CHAMPOLLION, *Mon.* ccccxvi [5]; ROSELLINI, *Mon. Civ.* xvi [2]; third register, scribe and metal-workers, CHAMPOLLION, *Mon.* ccclxx [3-5]; ROSELLINI, *Mon. Civ.* lii [2]; last group with blow-pipes, CAILLIAUD, *Arts et Métiers*, pl. 6 B [3] (called Qurna); herdsmen and some of the animals and birds from fourth to seventh registers, CHAMPOLLION, *Mon.* ccclxxi [1, 2]; ROSELLINI, *Mon. Civ.* xxix [2], xxx [4]; herdsmen with geese and cranes (part), CAILLIAUD, *op. cit.* pl. 21 B [1, 2]; tree and bird-traps, HAY*, 29850, 25-6, 180-1, 196-7 (tracings); bird and bird-traps, ROSELLINI, *Mon. Civ.* vi [4-5]; WILKINSON, *M. and C.* iii. 38 (No. 334, 1, 3) = ed. BIRCH, ii. 103 (No. 362, 1, 3); NEWBERRY and GRIFFITH, *op. cit.* iv, pl. xxii [2, 3]; WILKINSON MSS.* ii. 26 verso [fourth row, right], 27 A [19 lower].

(8)-(14) Wrestling, attack on fortress, and offering-list and offerings before statue of deceased, NEWBERRY and GRIFFITH, *op. cit.* ii, pl. xv; HAY*, 29813, 48-9, 74-5; see CHAMPOLLION, *Not. Descr.* ii. 350-1. (8)-(14) Top to fourth registers, (8)-(12) fifth register, wrestlers, CHAMPOLLION, *Mon.* ccclxxii-ccclxxviii; omitting first pair, ROSELLINI, *Mon. Civ.* cxi-cxvi [2-114]; some wrestlers, WILKINSON, *M. and C.* ii. 438 (No. 310, 1-10, 13, 14) = ed. BIRCH, ii. 71 (No. 338, 1-10, 13, 14); WILKINSON MSS.* ii. 27 A [19 upper]; BURTON MSS.* 25634, 45 verso [bottom], 49 verso [upper], 51; HAMILTON, *Aegyptiaca*, xxii [4 left]; cursive texts in wrestling scenes, NEWBERRY and GRIFFITH, *op. cit.* ii, pl. xix; CHAMPOLLION, *Not. Descr.* ii. 348-9; see view, JÉQUIER, *L'Architecture*, i, pl. 13 [2]. (8)-(12) Sixth to eighth registers, storming fortress, foreign soldiers, and Egyptian soldiers at bottom; omitting some soldiers, CHAMPOLLION, *Mon.* ccclxxx [1-3], ccclxxx [1-2]; ROSELLINI, *Mon. Civ.* cxviii [2-3], cxix [1-2]; archers, fortress, men with battering-ram and some soldiers, WILKINSON, *M. and C.* i. 305 (No. 27, left), 306 (No. 28), 360 (No. 60, 1), 316 (No. 36, 1) = ed. BIRCH, i. 203 (No. 32, left), 203 (No. 33), 242

(No. 74, 1), 210 (No. 42, 1); WILKINSON MSS.* ii. 23 B [bottom middle], 24 [middle]; fortress, battering-ram, and soldiers, BURTON MSS.* 25634, 44, 44 verso, 54 verso [lower]; dog with cursive text behind first archer in sixth register, CHAMPOLLION, *Mon.* ccccxxvi [4]; ROSELLINI, *Mon. Civ.* xvi [5]; text, CHAMPOLLION, *Not. Descr.* ii. 350 [top]; transcription, MONTET, op. cit. p. 16 [bottom]; eighth and ninth foreign soldiers before fortress from sixth register, MEYER, *Darstellungen der Fremdvölker*, 53; WRESZINSKI, *Atlas*, ii. 9 [A]; fight between two soldiers from eighth register, MEYER, op. cit. 262; WRESZINSKI, *Atlas*, ii. 9 [B]. (13)-(14) Fifth to eighth registers, offering-list, men sacrificing ox, and wine-jars before statue in shrine, and soldiers below; seventh register, men before statue in shrine, offerings and butchers, ROSELLINI, *Mon. Civ.* cxix [3]; men with statue, and offerings, CHAMPOLLION, *Mon.* ccclxiii [1]; statue and offerings, L. D. *Text*, ii, p. 104 [top]; offerings and butchers, L. D. *Ergänz.* xlviii [a].

(15)-(16) Upper part, top and second registers, vintage, third register, bird-trap and tree, with three registers games on right, NEWBERRY and GRIFFITH, op. cit. ii, pl. xvi [left upper]; vintage (omitting text), CHAMPOLLION, *Mon.* ccclxxx [3]; ROSELLINI, *Mon. Civ.* xxxvii [1]; man and bird-trap, CAILLIAUD, *Arts et Métiers*, pl. 37 A [2]; WILKINSON, *M. and C.* iii. 38 (No. 334, 5) = ed. BIRCH, ii. 103 (No. 362, 5); trap, ROSELLINI, *Mon. Civ.* vi [3]; two birds with names, id. ib. viii [7-8]; CHAMPOLLION, *Mon.* ccclii [top left, middle left]; WILKINSON, *M. and C.* iii. 48 (No. 339, 1-2) = ed. BIRCH, ii. 112 (No. 368, 1-2); WILKINSON MSS.* ii. 23 B [middle right], 30 [upper left]; names, CHAMPOLLION, *Not. Descr.* ii. 352 [top]; MONTET, op. cit. p. 17 [3 upper]; games, CHAMPOLLION, *Mon.* ccclxxxii [1, 2 upper]; ROSELLINI, *Mon. Civ.* cii [1, 2, 4]; WILKINSON MSS.* ii. 22 verso [bottom middle], 23 B verso [left], x. 22 [bottom], 23 [top]; top register on right, man carried, and third register, men playing game, WILKINSON, *M. and C.* ii. 168 (No. 148, right), 433 (No. 306) = ed. BIRCH i. 394 (No. 169 right), ii. 68 (No. 334); man carried, BURTON MSS.* 25634, 54 [upper right]; texts of games, CHAMPOLLION, *Not. Descr.* ii. 352 [middle]; L. D. *Text*, ii, p. 103 [middle]; MONTET, op. cit. p. 17 [3 lower]. Lower part, deceased and wife, with two female musicians and woman nursing child above, NEWBERRY and GRIFFITH, op. cit. ii, pl. xvi [left lower]; deceased and wife, CHAMPOLLION, *Mon.* ccclxxxii bis [1-2]; the three women, ROSELLINI, *Mon. Civ.* xcvi [6]; WILKINSON MSS.* x. 31; HAY*, 29850, 198-200 (tracings); grotesque animal by head of deceased, CHAMPOLLION, *Mon.* ccccxxviii bis [middle]; ROSELLINI, *Mon. Civ.* xxiii [4]; BURTON MSS.* 25634, 54 verso [upper]; HAY*, 29850, 202 (tracing); WILKINSON, *M. and C.* iii. 23 (No. 330, 5) = ed. BIRCH, ii. 93 (No. 358, 5); WILKINSON MSS.* x. 30 [lower], cf. ii. 23 B [near top right], 24 [middle right]; DAVIES, op. cit. in *N.Y. Metro. Bull.* Pt. ii, April 1933, p. 26, fig. 5; dog in front of deceased, CHAMPOLLION, *Mon.* ccccxxvi [2]; ROSELLINI, *Mon. Civ.* xvi [4]; WILKINSON MSS.* x. 32 [upper]; texts of deceased, L. D. ii. 143 d, and *Text*, ii, p. 103 [lower left]; texts of wife and grotesque animal, CHAMPOLLION, *Not. Descr.* ii. 353 [middle]; of animal, L. D. *Text*, ii, p. 103 [lower right]; MONTET, op. cit. p. 17 [bottom].

(17) Pilaster. Eight registers games, NEWBERRY and GRIFFITH, op. cit. ii, pl. xvi [middle]; CHAMPOLLION, *Mon.* ccclxxxii [2 lower, 3], ccclxxxii ter [1-3]; ROSELLINI, *Mon. Civ.* cii [3, 5-10], ciii [upper left]; WILKINSON MSS.* ii. 22 verso [bottom left], 23 B [left, top and middle], 23 B verso [right and middle], x. 23 [middle and bottom], 29, 30 [upper], 32 [lower]; HAY*, 29850, 206-24 (tracings); texts, CHAMPOLLION, *Not. Descr.* ii. 352 [bottom]-3 [top]; L. D. *Text*, ii, pp. 102 [bottom]-3 [top]; MONTET, op. cit. p. 18 [top]; top, third, fourth, and eighth registers, CAILLIAUD, *Arts et Métiers*, pl. 37 A [3-7]; man standing on head from top register, and second to fourth registers, WILKINSON, *M. and C.* ii. 169 (No. 149), 168 (No. 148, left), 422 (No. 297, with text), 423

(No. 298) = ed. BIRCH, i. 394 (Nos. 170, 169 left), ii. 61 (No. 324 with text), 62 (No. 325); man standing on head from top register, and second register, man carried by three others, BURTON MSS.* 25634, 54 [upper left]; fourth register, HAMILTON, *Aegyptiaca*, xxii [4 middle].

(18) Deceased followed by attendants and two dwarfs, NEWBERRY and GRIFFITH, op. cit. ii, pl. xvi [middle right]; texts, CHAMPOLLION, *Not. Descr.* ii. 353 [bottom]–354; of attendants and dwarfs, L. D. *Text*, ii, p. 102 [middle]; MONTET, op. cit. p. 18 [middle]; the dwarfs, CHAMPOLLION, *Mon.* ccclxxxi bis [3]; ROSELLINI, *Mon. Civ.* xciii [3–4]; WILKINSON, *M. and C.* ii. 436 (No. 309) = ed. BIRCH, ii. 70 (No. 337); WILKINSON MSS.* ii. 24 [near bottom], 25 verso [fourth row, middle left]; HAY*, 29813, 50 [bottom left], 78 [bottom left]; BURTON MSS.* 25634, 54 [lower]; dogs and ape in front of deceased, CHAMPOLLION, *Mon.* ccccxxviii [bottom left, and bottom middle], ccccxxviii ter [top right]; ROSELLINI, *Mon. Civ.* xvii [7–9], xxi [1].

(19) Pilaster. Six registers, with two attendants in each, NEWBERRY and GRIFFITH, op. cit. ii, pl. xvi [right]; see CHAMPOLLION, *Not. Descr.* ii. 355 [upper].

(20)–(23) Upper part, top register, statue of deceased in shrine, male and female dancers, men with funerary outfit, second register, men bringing cattle, NEWBERRY and GRIFFITH, op. cit. ii, pl. xvii [upper]; male dancers and one female dancer from top register, WILKINSON MSS.* ii. 29 B verso [middle upper left], 27 A [3 middle right]; texts, MONTET, op. cit. p. 18 [bottom]; of overseer, and of herdsmen, CHAMPOLLION, *Not. Descr.* ii. 358; spotted dog from second register, id. *Mon.* ccccxxviii [top middle]; ROSELLINI, *Mon. Civ.* xvii [2]; WILKINSON, *M. and C.* iii. 32 (No. 331, 4) = ed. BIRCH, ii. 99 (No. 359, 4).

(20)–(23) Lower part, top register, ox and oryxes, donkeys, reapers, granaries, tables, and bed with linen, second and third registers, bringing animals, offerings, &c., to deceased seated before offerings, and three registers flax-harvest, and ploughing beyond, NEWBERRY and GRIFFITH, op. cit. ii, pl. xvii [lower]; see CHAMPOLLION, *Not. Descr.* ii. 355 [middle]–357 [bottom]; shackling ox, and oryxes, from top register, HAY*, 29850, 203–5 (tracings); shackling ox, CHAMPOLLION, *Mon.* cccxc [4]; ROSELLINI, *Mon. Civ.* xxix [1]; two offering-bringers, and offerings from altar before deceased, *Descr. de l'Égypte, Ant.* iv, pl. 66 [5, 6]; offerings, ROSELLINI, *Mon. Civ.* cxxxiii [4]; cat and dog beneath chair, HAY*, 29850, 193, 201 (tracings); granaries and tables, id. ib. 29813, 50 [middle lower], 78 [middle lower]; granaries, CHAMPOLLION, *Mon.* ccclxxxi ter [4]; ROSELLINI, *Mon. Civ.* xxxv [3]; CAILLIAUD, *Arts et Métiers*, pl. 34 A [3]; WILKINSON, *M. and C.* ii. 135 (No. 121) = ed. BIRCH, i. 371 (No. 141); L. D. *Text*, ii, p. 101 [bottom]; WILKINSON MSS.* ii. 25 verso [fourth row, middle right], 27 A [16 top], cf. xii. 20 [bottom left]; BURTON MSS.* 25636, 12 verso; plough from bottom register, L. D. *Text*, ii, p. 102 [middle].

(24)–(25) Upper part, five registers men bringing goats, asses, and oxen, desert with trees and goats browsing, and eight boats, NEWBERRY and GRIFFITH, op. cit. ii, pl. xii [upper]; see CHAMPOLLION, *Not. Descr.* ii. 335–8; men with some of the goats and trees, id. *Mon.* ccclxv [1]; ROSELLINI, *Mon. Civ.* xxix [3]; hieratic texts above desert (omitted in NEWBERRY and GRIFFITH), CHAMPOLLION, *Not. Descr.* ii. 336–7; man with two bulls fighting, id. *Mon.* ccclxv [2]; ROSELLINI, *Mon. Civ.* xxvi [1]; HAY*, 29850, 76–80 (tracings); men at mooring-post and first boat, from fifth register, CHAMPOLLION, *Mon.* cccci bis [middle]; ROSELLINI, *Mon. Civ.* cvi [2]; HAY*, 29813, 50 [bottom right], 78 [bottom right]. Frieze-text, CHAMPOLLION, *Not. Descr.* ii. 335.

(24) Lower part, three registers, kneading, pounding and grinding corn, and cooking, beside painted false door, NEWBERRY and GRIFFITH, op. cit. ii, pl. xii [lower left]; false door, L. D. *Text*, ii, p. 101 [upper left].

(25) Lower part, three registers offering-list (destroyed), butchers and offering-bringers, NEWBERRY and GRIFFITH, op. cit. ii, pl. xii [lower right].

Pillars.

(26)–(27) Architraves. Texts, id. ib. pl. xviii [upper], cf. p. 62; northern end, L. D. ii. 142 k, and *Text*, ii, p. 100 [top].

(28)–(29) Architraves. Texts, NEWBERRY and GRIFFITH, op. cit. ii, pl. xviii [lower], cf. p. 62; L. D. *Text*, ii, p. 100 [middle].

18. UNINSCRIBED TOMB (unfinished). (7 of CHAMPOLLION.)

Plan, section, and elevations, NEWBERRY and GRIFFITH, op. cit. ii, pl. xxi, cf. p. 25; plan, *Descr. de l'Égypte, Ant.* iv, pl. 64 [9]; L. D. i. 58 [unnumbered, right of 7]. View of interior, NEWBERRY and GRIFFITH, op. cit. pl. xx; JÉQUIER, *L'Architecture*, i, pl. 13 [1]; CAPART, *L'Art Égyptien* (1911), pl. 128; id. *L'Architecture* (1922), pl. 71.

21. NEKHTI , Nomarch of the Oryx-nome; Overseer of the Eastern Desert; Mayor of Menat-Khufu. Dyn. XII. (8 of LEPSIUS.)

See NEWBERRY and GRIFFITH, *Beni Hasan*, ii, p. 26. Plan, section, and elevation, id. ib. pl. xxii; plan, L. D. i. 58 [8].

Hall.

South wall. Deceased watching four registers, bringing animals, bringing fowl, fowling with net, and fishing with net (west part destroyed), NEWBERRY and GRIFFITH, op. cit. ii, pl. xxii A, cf. p. 26; text of deceased, L. D. ii. 143 f, and *Text*, ii, p. 106 [top right].

West (entrance) wall, south of door. Name and title of Nekhti, Lector, NEWBERRY and GRIFFITH, op. cit. p. 26 [bottom].

(The other walls are blank.)

23. NETERNAKHT , Overseer of the Eastern Desert; Chancellor of the King of Lower Egypt; Overseer of prophets of Horus. Dyn. XII. (9 of LEPSIUS; 10 of CHAMPOLLION.)

See NEWBERRY and GRIFFITH, *Beni Hasan*, ii, pp. 27–9; CHAMPOLLION, *Not. Descr.* ii. 459 [10]. Plan, section, and elevation, NEWBERRY and GRIFFITH, op. cit. pl. xxiii; plan, L. D. i. 58 [9].

Hall.

East wall. Wife with small son offering to deceased with mother, Khnemhotp II (destroyed) seated before offerings, offering-lists and offerings, and two women before table, NEWBERRY and GRIFFITH, op. cit. ii, pl. xxiv; texts (omitting offering-lists), L. D. ii. 143 g, and *Text*, ii, p. 106 [lower]; table with food, *Descr. de l'Égypte, Ant.* iv, pl. 66 [7].

Ceiling. Texts, NEWBERRY and GRIFFITH, op. cit. ii, p. 28 [middle].

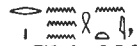
27. RAMU-SHENTI , Nomarch of the Oryx-nome; Belonging to Nekhen; Chief Nekhebite; &c. Dyn. XI (?). (10 of LEPSIUS.)

See NEWBERRY and GRIFFITH, op. cit. ii, pp. 30–1. Plan, section, and elevation, id. ib. pl. xxvi; plan, L. D. i. 58 [10].

Hall.

East and south walls. Frieze-texts, NEWBERRY and GRIFFITH, op. cit. ii, p. 31; L. D. *Text*, ii, p. 107 [top]; of east wall, L. D. ii. 143 h.

29. **BAKT I** , Nomarch of the Oryx-nome; Belonging to Nekhen; Chief Nekhebite; &c. Dyn. XI (?). (11 of LEPSIUS.) (See plan, supra p. 150.)

See NEWBERRY and GRIFFITH, *op. cit.* ii, pp. 32-6, pls. xxviii-xxxii. Plan and elevation, *id. ib.* pl. xxvii; plan, *L. D.* i. 58 [11].

Hall.

- (1) Effaced scenes, harvest and boats in two lowest registers.
 (2) Six registers trades and bringing produce, and boats at bottom before deceased (much destroyed).
 (3)-(4) Deceased, followed by three registers attendants, watching three registers catching game, netting fowl, and bringing and netting fish, with men and cattle crossing inundation below deceased, NEWBERRY and GRIFFITH, *op. cit.* ii, pl. xxviii, cf. p. 33.
 (5)-(6) At top, hunting-scene (continued from top register of 3-4), lower part, deceased with wife and son fowling in marshes, and three registers men in canoes bringing papyrus and crews quarrelling, *id. ib.* pl. xxix.
 (7)-(8) Deceased watching three registers men with gazelle and oxen, and at bottom calf brought, and butchers (destroyed), *id. ib.* pl. xxx [left].
 (9)-(10) Offering-bringers and offering-list before deceased, with butchers and servants below, *id. ib.* pl. xxx [middle]; text above deceased, and columns at either end of scene, *L. D. Text*, ii, p. 107 [bottom].
 (11)-(12) Five registers attendants bringing furniture, ichneumon, dog, &c., with butchers and painted false door below, NEWBERRY and GRIFFITH, *op. cit.* ii, pl. xxx [right].
 (13)-(14) Deceased with two attendants watching four registers, bull overturned and goats browsing, bulls fighting, cows and bull, lioness attacking bull, &c., *id. ib.* pl. xxxi, cf. p. 35; one bird (on bush), CHAMPOLLION, *Mon.* cccliii [bottom left].
 (15)-(16) Deceased followed by two attendants and three dwarfs, watching five registers, wrestlers, men with goats, men with oxen, bulls fighting, and ploughing, NEWBERRY and GRIFFITH, *op. cit.* ii, pl. xxxii, cf. p. 36; text above bull fighting, *L. D. Text*, ii, p. 107 [lower middle].
 (17) Deceased and voyage to Abydos (effaced).

33. **BAKT II** , Nomarch of the Oryx-nome; Belonging to Nekhen; Chief Nekhebite; &c. Dyn. XI (?). (12 of LEPSIUS.) (See plan, supra p. 150.)

See NEWBERRY and GRIFFITH, *Beni Hasan*, ii, pp. 37-40, pls. xxxv, xxxvi. Plan and elevation, *id. ib.* pl. xxxiv; plan, *L. D.* i. 58 [12].

Hall.

- (1)-(2) (Lower part destroyed.) Deceased in kiosk watching two registers men bringing game and netting fowl, NEWBERRY and GRIFFITH, *op. cit.* ii, pl. xxxv [lower].
 (3)-(4) At top, men catching game in desert, and below, deceased harpooning (cut through by doorway to Tomb 32), and remains of marsh-scene; omitting marsh scene, *id. ib.* pl. xxxv [upper].
 (5)-(6) At top, offering-bringers, and below, deceased with servant, three registers offering-bringers, offering-list with butchers beneath, and deceased seated with two registers cooks and butchers, and men bringing cattle beneath; offering-bringers from top with text above them, *id. ib.* pl. xxxvi [A, B, C], cf. p. 39.
 (7) and (8) Destroyed scene before deceased seated, and deceased followed by dwarf

watching hunting and agriculture, see id. ib. p. 40. Text at top of wall, id. ib. p. 39 [bottom].

(9) False door, id. ib. pl. xxxvi [D].

Tombs of officials, Dyn. VI-XII.¹ Below Dyn. XII Rock-tombs.

See GARSTANG, *The Burial Customs of Ancient Egypt*, passim; id. *Excavations at Beni-Hasan (1902-1903-1904)* in *Ann. Serv.* v, pp. 215-28, pls. i-vi.

Plans of site, id. *Burial Customs* [&c.], pls. iii, iv, opposite p. 52.

I. ANTEF , Intimate.

View, model boats, granary, baking, brewing, and girl with basket and birds, id. ib. pp. 54-65, figs. 39, 41-51, cf. pl. vii; view of interior, and boats, id. *Excavations at Beni-Hasan, 1902-3* in *Man* (1903), pls. G [1], 1-J [top], cf. pp. 98 [54], 129 [74]; see id. op. cit. in *Ann. Serv.* v, p. 220.

75. NETERUHOTP , Steward.



Coffin, in Cairo Mus. 37565; texts, LACAU, *Notes sur les textes religieux contenus dans les sarcophages de M. Garstang* in *Ann. Serv.* v. 246-9; part, id. *Textes religieux in Rec. de Trav.* xxx. 195-6 [D]; offerings painted on end panels of interior, GARSTANG, *Burial Customs* [&c.], pl. vi opposite p. 168, cf. pl. vii. Ka-figure concealed in panel of coffin, id. ib. p. 104, fig. 93.

116. NEFERU , Physician.

View, coffins, and models of boats, granary, baking, brewing, &c., in Cairo Mus., id. ib. pp. 65-79, 148, figs. 52-66, 146, cf. pl. vii; id. op. cit. in *Ann. Serv.* v, pls. i-iii, cf. pp. 216-19, 220; rowing-boat, granary, and brewers, id. op. cit. in *Man* (1903), pl. G [116], cf. p. 98 [54]; texts of coffin, No. 37563, LACAU, op. cit. in *Ann. Serv.* v. 237-45.

186. THAUI , good name 'ANTI-EMHËT , Overseer of the seal.

View, coffins, cartonnage, canopic box, and models of boats, granary, bakers, brewers, and butchers, &c. (war-boat in Oxford, Ashmolean Mus., the rest in Cairo Mus.), GARSTANG, *Burial Customs* [&c.], pp. 79-89, 151, 157-8, 161, 178-9, figs. 67-79, 149, 157, 158, 164, 185 [right], 186, cf. pl. vii; id. op. cit. in *Ann. Serv.* v, pls. iv-vi, cf. pp. 220-1; war-boat [= figs. 149, 157, 158], id. op. cit. in *Man* (1903), pl. G [186], cf. p. 98 [54]; texts of coffins, in Cairo Mus., 37564 a, b, LACAU, op. cit. in *Ann. Serv.* v. 230-7.

481. IPI  or HERIBI , Ruler of the Residence; Intimate. Old Kingdom, re-used Middle Kingdom. (Rock-tomb).



See GARSTANG, *Burial Customs* [&c.], pp. 36-41, figs. 25-8, cf. p. 188, and pl. viii.

Entrance.

Left jamb, figure of deceased, id. ib. p. 37, fig. 26.

Hall.

West wall. False doors of deceased and of wife Sent , id. ib. p. 38, fig. 27.

482. BEBI , Friend, Prophet, and NI-PEPY . Dyn. VI. (Rock-tomb.)

Hall.





West wall. Inscribed double panel, id. ib. p. 42, fig. 29, cf. p. 188, and pl. viii.

¹ The marginal tomb-numbers are those of GARSTANG.

500. MA , Overseer of land. Middle Kingdom.

Coffin, in Brussels, Musées Royaux du Cinquantenaire, E. 5037, id. ib. p. 150, fig. 148, cf. pl. viii; texts, SPELEERS, *Rec. des Inscr. Ég.* 22-9 [85]; list of festivals from exterior [= SPELEERS, 22-3, ll. 3, 4, 6, 7, 9, 10, 14, 15, 16, 18, 20, 21], GARSTANG, op. cit. pl. ix opposite p. 190, cf. 192-3; part of Chapter xvii of the Book of the Dead from interior of lid [= SPELEERS, 25-9], SPELEERS, *La version du chapitre xvii du Moyen Empire* in *Rec. d'Études Égyptologiques dédiées à . . . Champollion*, pl. xiv, cf. pp. 621-49.

Model sailing-boat (in Oxford, Ashmolean Mus.), and model rowing-boat (in Cairo Mus.), GARSTANG, op. cit. p. 102, fig. 91; see id. op. cit. in *Ann. Serv.* v. 222.

585. KHNEMNEKHTI  , Ruler of the Residence, and woman NETERNEKHTI  . Middle Kingdom.





Coffin of Khnemnekhti, canopic box, models of butchers, bakers, boats, granary, &c., in Cairo Mus., GARSTANG, *Burial Customs* [&c.], pp. 89-98, 160-1, 164, figs. 80-90, 163, 164 [right], 167, cf. pl. viii; one boat [= fig. 163], id. *Excavations at Beni-Hasan* [&c.] in *Man* (1904), pl. G [bottom left]; see id. op. cit. in *Ann. Serv.* v. 222-3.



Coffins of Neternekhti, in Oxford, Ashmolean Mus.; texts, BLACKMAN, *Some Middle Kingdom Religious Texts* in *Ä.Z.* xlvi. 116-129; corrections, id. *Some Chapters of the Totenbuch and other Texts on a Middle Kingdom Coffin* in *Ä.Z.* xlix. 65-6.





707. IPI  , Steward.

Coffin, death-mask, and models of granary, bakers, and female servant, in Liverpool, Inst. Arch., GARSTANG, *Burial Customs* [&c.], pp. 169-72, 124, 127, 109, figs. 173-7, 120, 125, 98, cf. pl. viii; see id. op. cit. in *Ann. Serv.* v. 223.















VARIOUS













Coffins of woman Wa'rt'ankh   (tomb 39), and of Userhet  , Warrior (tomb 132), outer coffin of latter in Liverpool Mus., and inner in Cambridge, GARSTANG, *Burial Customs* [&c.], pp. 167, 149, 174-5, 191, figs. 169, 147, 180-1, cf. pl. viii.

Fragments of coffin of Khnemhotpi  , in Oxford, Ashmolean Mus.; texts, BLACKMAN, op. cit. in *Ä.Z.* xlix. 54-65.

Ka-figure of Neternekhti (tomb 720) and coffin and *ka*-figure of Sebkhōtpi     (tomb 723), in Brit. Mus., GARSTANG, op. cit. pp. 138-9, 168, 237, figs. 135, 136, 170, 231, cf. p. 103, and pl. viii; *ka*-figure of Neternekhti, id. op. cit. in *Man* (1904), pl. G [middle left], cf. p. 98 [67].

Canopic box of Khnemhotp (tomb 107), Old Kingdom (?), id. *Burial Customs* [&c.], p. 178, figs. 184, 185 [left].

Stelae of Hetef  , Lady of the House (tomb 85), Userhetai    , Steward (tomb 163), Harhurekhyt-hotp     (tomb 211), Neternakht   (tomb 320), and Neheri   (tomb 360), GARSTANG, op. cit. pp. 185-7, figs. 191-5, cf. pls. vii, viii; of Hetef, in Brit. Mus. 625, *Hiero. Texts* [&c.], Pt. iii, pl. 50; see *Guide, Sculpture* (1909), p. 55 [182].

Models of sacrifice and baking and brewing from tomb of Khety     (No. 366), in Cambridge, Fitzwilliam Mus., and models from tomb of Khetyi     (No. 575), including spinners and weavers, in Liverpool Inst. Arch., granary, bakers and brewers with butchers, and dwarf, and female servant, all in Oxford, Ashmolean Mus., and mode of Libyan woman with baby from tomb of Useri     (No. 181), GARSTANG, op. cit.

pp. 105, 127, 125, 129, 133, 140, figs. 94, 124, 121, 127, 131, 138; names, id. ib. pls. vii, viii; id. op. cit. in *Ann. Serv.* v. 221-2; sacrifice [=fig. 94], id. op. cit. in *Man* (1903), pl. G [366], cf. p. 98 [54]; Libyan woman [=fig. 138], id. ib. pl. I-J [bottom], cf. p. 130 [74].

Models of butcher, overseer, man feeding ox, brick-makers, and leather-worker, from tomb of Thaa'y , Intimate, Steward (No. 275), in London, South Kensington Mus., GARSTANG, *Burial Customs* [&c.], pp. 105, 126, 131, figs. 95, 123, 129, cf. pl. vii; brick-makers and leather-workers, id. op. cit. in *Man* (1903), pl. G [275], cf. p. 98 [54]; see id. op. cit. in *Ann. Serv.* v. 221.

Jewellery of Senbu  (tomb 487), GARSTANG, *Burial Customs* [&c.], pl. v opposite p. 114, cf. pp. 113-14 and pl. viii.

Nuérât, north of Dyn. XII Rock-tombs.

ROCK-TOMBS. Dyn. III and IV.

See id. ib. pp. 26-30, figs. 14-18.

South Beni Hasan.

ROCK-TOMBS. Dyn. XX-XXX. Above mouth of valley of Speos Artemidos.

See id. ib. pp. 201-8, figs. 214-27.

ROCK-TOMBS. Dyn. V and VI. South of valley of Speos Artemidos.

See id. ib. pp. 30-5, figs. 19-24.

Ka-figure from tomb 1015, and defaced shrine with male and female figures, id. ib. p. 31, figs. 19, 20, p. 35, fig. 24.

STONE TOMB. Saite. About twenty metres from the village of Beni Hasan el-Shurûq.

ENGELBACH, *Saite tomb discovered at Beni Hasan* in *Ann. Serv.* xxiv, pp. 159-60 and plate.

ISTABL 'ANTAR (SPEOS ARTEMIDOS)

GREAT SPEOS. Hatshepsut and Tuthmosis III, and Sethos I. (See plan, supra p. 150.)

See CHAMPOLLION, *Not. Descr.* ii. 322-34; *L. D. Text*, ii, pp. 108-11. Plan, CHAMPOLLION, *Not. Descr.* ii. 323; *L. D. Text*, ii, p. 108; BURTON MSS.* 25634, 60 [upper]; WILKINSON MSS.* ii. 29 B [bottom, near left], xvii. J. 9 verso. Description with plan, SAINT-FERRIOL MSS.* Diary, May 13, 1842; description, BONOMI MSS.* Diary, June 22, 1831. Rough sketch, NESTOR L'HÔTE MSS.* 20396, 244 verso [lower].

General view, GARSTANG, op. cit. p. 200, fig. 213.

Façade.

View of outer and inner faces, JÉQUIER, *L'Architecture*, i, pl. 27; of outer face, WRESZINSKI, *Bericht über die photographische Expedition* [&c.], pl. 14 [A]; MURRAY, *Egyptian Temples*, pl. viii opposite p. 31; of inner face, KEES, *Kulturgeschichte des alten Orients*, i, *Ägypten*, pl. 41 [upper].

(1)-(2) Exterior architrave. Long text of Hatshepsut, MASPERO, *Grande Inscription de Stabel-Antar (Spéos Artémidos)* in *Rec. de Trav.* vi, plate opposite p. 20; SETHE, *Urk.* iv. 383-91 (120); parts, GOLÉNISCHEFF, *Notice sur un texte hiéroglyphique de Stabel Antar (Spéos Artémidos)* in *Rec. de Trav.* iii. 1-3.

Portico. Hatshepsut and Tuthmosis III.

(3) Thoth before Ennead, L. D. iii. 26 [7]; LEPSIUS, *Über den ersten Aegyptischen Götterkreis* [&c.] in *Abhand. d. Preuss. Akad. d. Wiss.* (1851), pl. i [ii] (reversed and rearranged); CHAMPOLLION, *Not. Descr.* ii. 330-1 [left], 328 [left]; Ennead, WILKINSON MSS.* ii. 29 B [bottom middle]; text of Ennead and first text of Thoth, SETHE, *Urk.* iv. 289-91 (91) B.

(4) Wert-Hekau Pa'kht, and King kneeling before Amen-rē', CHAMPOLLION, *Mon.* ccclxxxv [4]; WILKINSON MSS.* ii. 29 B [middle left]; goddess, text of Amen-rē', and renewal-text of Sethos behind him, L. D. *Text*, ii, p. 110 with *a*; texts of Amen-rē' and King, CHAMPOLLION, *Not. Descr.* ii. 327 [top and bottom]; renewal-text, id. ib. 329 [right].

(5) King between Amen-rē' and Wert-Hekau Pa'kht wearing disk; goddess and texts, id. ib. 328 [right]-329 [left and middle]; texts of goddess and Amen-rē', SETHE, *Urk.* iv. 286-7 (90) C, 285 (89) K.

(6) King before goddess with serpent-sceptres, CHAMPOLLION, *Mon.* ccclxxxv [1]; head and text of goddess, WILKINSON MSS.* ii. 29 B [top right]; text, CHAMPOLLION, *Not. Descr.* ii. 331 [middle right]; SETHE, *Urk.* iv. 287 (90) D.

(7) King before Thoth; text of Thoth, and text behind King, CHAMPOLLION, *Not. Descr.* ii. 332 [top and left]; omitting part of text of Thoth, WILKINSON MSS.* ii. 29 B [middle right]; text behind King, L. D. iii. 138 i; titles of Thoth, L. D. *Text*, ii, p. 110 [top].

(3)-(7) Base. Dedication-texts; east half, WILKINSON MSS.* ii. 29 B verso [top]; part, CHAMPOLLION, *Not. Descr.* ii. 332 [bottom]; west half, id. ib. 332 [middle right]; L. D. iii. 138 h; SHARPE, *Eg. Inscr.* 2 Ser. 60 [9, 10]; WILKINSON MSS.* ii. 29 B verso [near top].

Pillars.

(8), (9), (10), (11), (12), (13) Dedication-texts of Tuthmosis III and Sethos I, CHAMPOLLION, *Not. Descr.* ii. 323 [lower], 324 [top]; L. D. iii. 138 k, l, m, and *Text*, ii, pp. 108 with *a*-109 [upper]; BURTON MSS.* 25634, 60 [lower]; WILKINSON MSS.* ii. 29 B [left], vi. 127 [middle].

Entrance to Sanctuary. Sethos I.

(14) Lintel, double-scene, King running with oar and vase to Pa'kht; left scene, WILKINSON MSS.* ii. 29 B [top, middle left]; texts, CHAMPOLLION, *Not. Descr.* ii. 326, 327 [left]; part of text of King, L. D. *Text*, ii, p. 109 [bottom]; KEES, *Nachlese zum Opfertanz des ägyptischen Königs* in *Ä.Z.* lii. 66 [top].

(15) and (16) Jambs, figures of Sethos; part of texts, CHAMPOLLION, *Not. Descr.* ii. 333 [upper left].

(17) Nineteen lines of text, DE ROUGÉ, *Inscr. Hiéro.* cxlix-clii (said to be from exterior); first line, L. D. *Text*, ii, p. 111 [top].

(18) King offers wine to goddess; texts, CHAMPOLLION, *Not. Descr.* ii. 333 [middle lower].

(19) King offers baboon and receives sceptre from goddess, see id. ib. ii. 333 [near bottom].

Frieze of cartouches of Sethos I above (18) and (19), id. ib. 333 [bottom]; BURTON MSS.* 25634, 61.

Sanctuary.

(20)-(21) Shrine; dedication-texts of Sethos on jambs, CHAMPOLLION, *Not. Descr.* 334 [upper].

SMALL SPEOS. Roman. West of Great Speos.

Entrance.

View, WRESZINSKI, op. cit. pl. 14 [B].

Doorway. Cornice, cartouches of Alexander II, lintel, left side, three scenes, King before Horus, before Amen-rē', and with a goddess offering image of Ma'et to Pa'kht, right side, three scenes, King before Shu, before a god, and with Hathor (?) offering image of Ma'et to Pa'kht; sketch, WILKINSON MSS.* ii. 28 [lower left a]; cartouches from lintel, CHAMPOLLION, op. cit. ii. 463; L. D. *Text*, ii, p. 111 [bottom].

ROCK-TOMB. Roman (?). A little way east of last.

Hall.

Rear wall. Two boats and deceased seated before offerings; sketch and remains of text, NESTOR L'HÔTE MSS.* 20396, 244; see description, BONOMI MSS.* Diary, June 22, 1831.

ROCK-STELA. Tuthmosis III. Higher up same valley.

Texts, CHABÂN, *Fouilles à Achmounéïn* in *Ann. Serv.* viii. 223 [iii].





IX. BETWEEN BENI ḤASAN AND EL-'AMARNA

(BALANŞÛRA TO EL-SHEIKH SA'ÏD)

WEST BANK

BALANŞÛRA

NECROPOLIS. Two kilometres south-west of village.

Statues of Iny , Mayor of Neferus , and his wife Mutnûfer , dedicated by their son Ma'hu , Mayor of Neferus, temp. Amenophis IV, in Cairo Mus.; texts, DARESSY, *Deux statues de Balansourah* in *Ann. Serv.* xviii. 53-5.

EL-ASHMÛNEIN (HERMOPOLIS MAGNA)

ROEDER, *Der Urzeit-Bezirk und die Urgottheiten von Hermopolis* in *Ä.Z.* lxxvii. 82-8; id. *Vorläufiger Bericht über die Ausgrabungen in Hermopolis 1929-1930*,¹ passim; id. *Vorläufiger Bericht über die deutsche Hermopolis-Expedition 1931 und 1932*,² passim; SCHMITZ, *Topographie von Hermopolis Magna* (Freiburg 1921), passim. Plan of site, *Descr. de l'Égypte*, *Ant.* iv, pl. 50, cf. *Texte*, iv, pp. 165-79; CHABÂN, *Fouilles à Achmounéïn* in *Ann. Serv.* viii, p. 213, fig. 1; ROEDER, *Hermopolis 1929-1930*, pl. xiv; south-west part within enclosure, id. *Hermopolis 1931 und 1932*, pl. xiv and plan at end; sketch-plan, id. op. cit. in *Ä.Z.* lxxvii, p. 83, Abb. 1; id. *Hermopolis 1931 und 1932*, p. 5. Description, NESTOR L'HÔTE MSS.* 20396, 268-9, 301; BONOMI MSS.* Diary, Jan. 14, 1825, June 25-7, 1831.

TEMPLE OF THOTH (HERMES TRISMEGISTOS). Alexander the Great and Philip Arrhidaeus.

Plan and elevation, *Descr. de l'Égypte*, *Ant.* iv, pl. 52 [1, 2]; POCOCCO, *A Description of the East*, i, pl. xxiv [c, d] opposite p. 73; plan, MINUTOLI, *Reise zum Tempel des*

¹ Also published in *Mitteil. d. Deutsch. Inst. Kairo*, ii, same pages and plates.

² Also published in *Mitteil. d. Deutsch. Inst. Kairo*, iii, same pages and plates.

TEMPLE OF
ALEXANDER
AND PHILIP

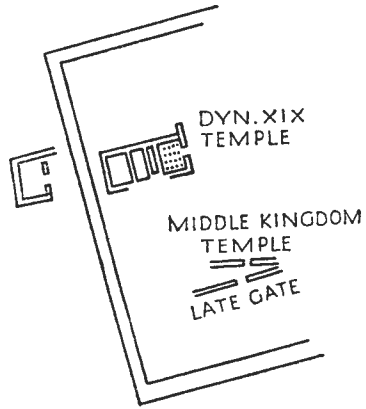

COLOSSI

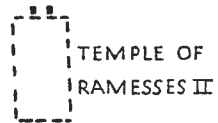

VILLAGE OF
EL-ASHMÛNEIN

EL-ASHMÛNEIN. KEY-PLAN.
Adapted from ROEDER, *Hermopolis 1929-1930*, pl. xiv.

Jupiter Ammon [&c.], xiv [5]. View showing Portico (destroyed in 1822, cf. WILKINSON, *M. and C.* 2 Ser. ii. 4), *Descr. de l'Égypte, Ant.* iv, pl. 51; DENON, *Voyage* (1802), pl. 33 [1]; HAMILTON, *Aegyptiaca*, xiv; MASPERO, *Hist. Anc. des Peuples de l'Orient, Les Empires*, fig. on p. 175.

FAÇADE.

Outer face; frieze of cartouches of Alexander, architrave, eight scenes of King before gods, and soffits between columns, MINUTOLI, op. cit. xiv [1] (giving cartouches of Philip in error); WILKINSON MSS.* i. 133 [middle, omitting small scene at right]; see *Descr. de l'Égypte, Ant.* iv, pl. 52 [2, 4, 6, 7], cf. *Texte*, x, pp. 411-12.

Inner face of architrave, dedication-text of Philip and scenes with two figures of King offering to Thoth, WILKINSON MSS.* i. 133 [top, and middle right]; offering-scene, MINUTOLI, op. cit. xiv [6].

Columns. Philip.

One column with text of Philip on base, id. ib. xiv [3]; omitting text, WILKINSON MSS.* i. 133 [right]; dedication-text on base, SHARPE, *Eg. Inscr.* 2 Ser. 60, l. 11; SETHE, *Urk.* ii. 9 (6); BURTON MSS.* 25636, 15 verso, cf. 16 [top]; part, BRUGSCH, *Thes.* 852 [bottom]; DARESSY, *Remarques et Notes in Rec. de Trav.* x. 143 [x upper].

Cartouches of Alexander from inner face of a column (?), WILKINSON MSS.* i. 133 [left].

TEMPLE OF THOTH. Dyn. XIX.

See ROEDER, *Hermopolis 1929-30*, passim; SAYCE, *Notes from Egypt in P.S.B.A.* xxiv. 86. Plan, CHABÂN, op. cit. in *Ann. Serv.* viii, p. 215, fig. 2. View, ROEDER, op. cit. pl. xv [a]; CAPART, *Impressions de Voyage in Chronique d'Égypte*, July 1927, p. 116.

IN FRONT OF PYLON.

Red granite colossal statue (with limestone base), Ramesses II usurped by Merneptah, with Prince Sety-Merneptah (afterwards Sethos II) in relief on left side, in Cairo Mus., MASPERO, *Le Musée Égyptien*, ii, pl. xiii [B], pp. 37-40; texts, CHABÂN, op. cit. 211-12; see MASPERO, *Guide* (1914), pp. 4-5, 151.

FAÇADE.

Right (north) side. Merneptah offers to Thoth with six divinities, and long text below, CHABÂN, op. cit. pl. i, pp. 216-18.

ENTRANCE.

South thicknesses, four registers, Sethos II embraced by Thoth, receives sign of life from Thoth, from Rē'-Harakhti, and from Amen-rē', and beyond offers image of Ma'et to Thoth, with column of text at inner end, id. ib. pl. ii, pp. 219-20 (called north side), 214 (inaccurate).

North thicknesses, four registers, Sethos II before divinities, and beyond offers incense and flowers to Amen-rē', with column of text at inner end, id. ib. pl. iii, cf. p. 214.

FINDS.

Re-used block with remains of relief of seated King and Queen (?), temp. Amenophis IV (?), ROEDER, op. cit. pl. xxv [a], cf. p. 109.

Stela, man before Ptaḥ and Ma'et, Dyn. XIX, found in débris above western chambers, id. ib. pl. xxv [d], cf. p. 109.

Head of statue of priest with offering-text on back, Ptolemaic (?), id. ib. pl. xxv [b, c], cf. pp. 109-10.

MIDDLE KINGDOM TEMPLE. (Destroyed.)

See id. *Hermopolis 1931 und 1932*, pp. 20-1; BITTEL and HERMANN, *Hermopolis* (in the press).

PYLON. Amenemhēt II. At entrance to Court.

See ROEDER, op. cit. pp. 11-20, 27-34, with Abb. 1-9, cf. plan at end; id. op. cit. in *Ä.Z.* lxxvii, p. 86, Abb. 2. Views, id. *Hermopolis 1931 und 1932*, pl. i.

South Face.



West jamb, two destroyed scenes, King offers milk to ram-headed god of Hermopolis, and bread to Thoth, with dedication-text below, id. ib. pl. iii [b], and pp. 27-31 with Abb. 13; texts, id. op. cit. in *Ä.Z.* lxxvii. 85-6; of upper scene, CHABÂN, op. cit. in *Ann. Serv.* viii. 221.

North Face.

West jamb, remains of four columns dedication-text of King, ROEDER, *Hermopolis 1931 und 1932*, pl. iii [a], and pp. 31-2 with Abb. 14; id. op. cit. in *Ä.Z.* lxxvii. 86 [middle].

Block with lower part of two figures of King, probably from lintel, id. *Hermopolis 1931 und 1932*, p. 34, Abb. 15.

Found near Pylon.

Fragments of six votive stelae, Dyn. XVIII, including one of Prince Sipaar , son of Amosis, and his sister Meramün , and one of Dḥutnūfer , Priest, before Thoth as baboon, id. ib. pp. 38-40 with Abb. 18-20.

Offering-basin with kneeling figure of Neḥem'a(w)y , Scribe of the endowments of all the gods of Upper and Lower Egypt, Dyn. XIX, id. ib. pl. v, and p. 40.

LATE GATE

See id. ib. pp. 21-6 with Abb. 10-12, and on plan at end. View, id. ib. pl. ii.

Re-used blocks.

Block with erased name of Hatshepsut, see id. ib. p. 23.

Granite block with two scenes of Amenophis IV, Queen Nefertiti, and Princess Merytaten, adoring Aten, id. ib. pl. iv, pp. 34-7 with Abb. 16, 17.

Two other blocks of Amenophis IV; remains of texts, id. ib. p. 37 [middle].

Block with remains of cartouche of Merneptah; text, id. ib. p. 37 [bottom].

TEMPLE OF RAMESSES II. (Destroyed.)

ENTRANCE.

Colossal seated statues of King on either side, ROEDER, *Hermopolis 1929-30*, pls. xv [b], xvi [b], xvii [b], cf. pp. 95, 109; texts of Princesses Bent'anta and another (both destroyed) from west statue, CHABÂN, op. cit. 222 [top].

FINDS

Altar of Nektanebos I (Nekht-neb-f); text on pedestal, DARESSY, *Notes et Remarques in Rec. de Trav.* xx. 86 [clxvi].

Two black basalt obelisks of Nektanebos II (Nekht-ḥar-ḥebi), perhaps from here, in Brit. Mus. 523, 524, see *Guide, Sculpture* (1909), p. 247 [919, 920] (said to come from Delta); BOYLAN, *Thoth the Hermes of Egypt*, p. 164.

Block in wall with cartouches of Alexander the Great (called Alexander II); text, DARESSY, op. cit. in *Rec. de Trav.* x. 143 [x lower].

Sun-clock of Tuthmosis III, in Berlin Mus. 19744, BORCHARDT, *Altägyptische Sonnenuhren* in *Ä.Z.* xlvi, pl. i, cf. p. 10; text, *Aeg. Inschr. Mus. Berlin*, ii. 311.

Stela with ram and goose of Amün, bought at El-Ashmûnein, CLÉDAT, *Notes archéologiques et philologiques* in *Bull. Inst. Fr. Arch. Or.* ii, p. 69, fig. 9, cf. p. 70.

Black basalt statue of Kamosi , Dyn. XVII, bought at Mallawi but probably from here, in London, University Coll., CAPART, *Recueil de Mon. Ég.* pl. lxvii, cf. description of plates.

TÛNA (TANIS SUPERIOR)

(For the rock-stelae, year 6 of Amenophis IV, see El-Amarna, infra p. 230.)

NECROPOLIS OF HERMOPOLIS MAGNA

Dyn. XVIII-XX, Saite, and Graeco-Roman.

See CHASSINAT in *Archaeological Report* (1903-4), pp. 31-3; WEILL, *Fouilles à Tounah et à Zaouiet el-Maietin* in *Comptes Rendus* (1912), 484-8; id. *Quelques types de figurines funéraires des XIX^e et XX^e Dynasties* in *Mon. Piot*, vol. xxv, pp. 419-25.

TOMB OF PEDUSIRI¹ , High Priest of Thoth. Middle of 4th century B.C. (but see CAVAIGNAC, *La date du Tombeau de Pétosiris* in *R.E.A.* ii. 56-7). Near Dirwa.

Complete, LEFEBVRE, *Le Tombeau de Petosiris*, in three volumes; id. *Le Tombeau de Petosiris* in *Ann. Serv.* xx. 41-121, 207-36, xxi. 40-60, 145-62, 222-46, xxii. 33-48, 139-56; see id. *L'œuf divin d'Hermopolis* in *Ann. Serv.* xxiii. 65-7. Plans and sections, id. *Le Tombeau de Petosiris*, ii, frontispiece, iii, pls. i-iii; plan, id. op. cit. in *Ann. Serv.* xx, pl. i oppositè p. 80. Views, id. *Le Tombeau de Petosiris*, iii, pls. iv [2], lviii; CAPART, *Impressions de Voyage* in *Chronique d'Égypte*, July 1927, 112-13; of façade, LEFEBVRE, *Le Tombeau de Petosiris*, iii, pl. vi, cf. v; id. op. cit. in *Ann. Serv.* xx, pl. ii; WRESZINSKI, *Bericht über die photographische Expedition* [&c.], pl. 16.

Façade and Entrance.

(1)-(2) Doorway. West jamb, LEFEBVRE, *Tombeau*, iii, pl. vi [2 left]; text of lintel, id. ib. ii, p. 2, cf. i, p. 43; text of Pedusiri on jamb, id. ib. ii, pp. 2-3, cf. i, pp. 43-4; id. op. cit. in *Ann. Serv.* xx. 62 [upper].

(3)-(4) Doorway. East jamb, id. *Tombeau*, iii, pl. vi [1 right]; ii, p. 3, cf. i, pp. 43-4; text of lintel, id. op. cit. in *Ann. Serv.* xxi. 162.

(6) Thickness; speech of Pedusiri, id. *Tombeau*, ii, p. 3, cf. i, p. 44; id. op. cit. in *Ann. Serv.* xx. 62 [lower].

(8) Thickness; speech of Pedusiri, id. *Tombeau*, ii, p. 4, cf. i, p. 44.

(5)-(6), (7)-(8) Thicknesses. Frieze-texts; speech of Pedusiri, id. ib. ii, pp. 3, 4, cf. i, p. 44, iii, pl. lviii [1, left].

(11), (13), (18), (20) North faces of columns. Titles of Pedusiri, id. ib. ii, pp. 4-7, cf. i, pp. 45, 46, 47; text on (11), id. op. cit. in *Ann. Serv.* xx. 59.

(12) and (14) Pedusiri offers libation to ibis-headed Thoth, and food to ape-headed Thoth; texts, id. *Tombeau*, ii, pp. 4, 5, cf. i, p. 46.

(15)-(16) Second and third registers, Pedusiri offers libation to Sokari-Osiris, and ointment to Nephthys, id. ib. ii, pp. 5-6, cf. i, p. 46; names of offerings, id. op. cit. in *Ann. Serv.* xx. 60.

¹ The arrangement and numbering are those of LEFEBVRE.

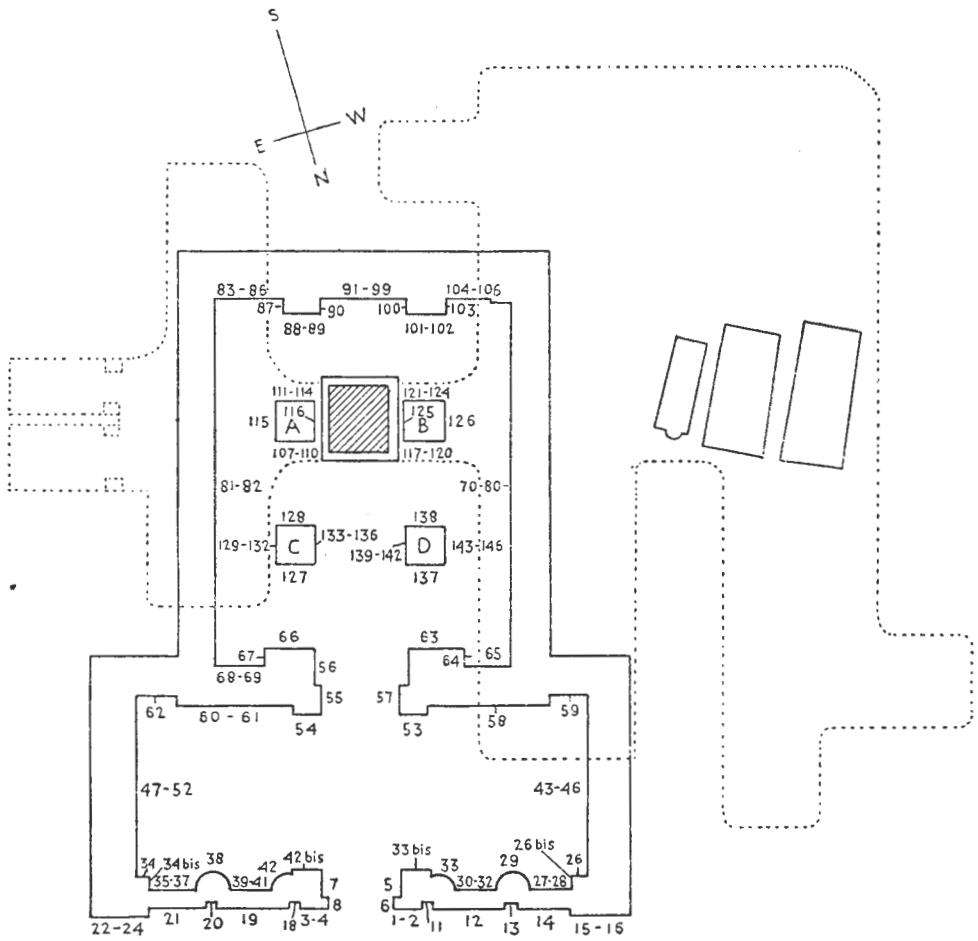

TÛNA (TANIS SUPERIOR). Tomb of Pedusiri. From LEFEBVRE, *Le Tombeau de Petosiris*, ii, frontispiece, iii, pl. ii.

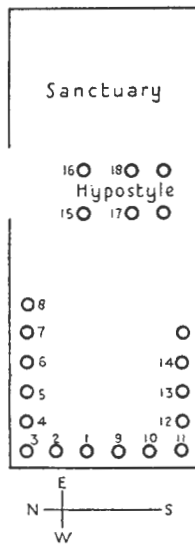

EL-SHEIKH 'IBÂDA (ANTINOË). Temple of Ramesses II. From GAYET in *Ann. Mus. Guimet*, xxvi [3], p. 18.

(19) and (21) Pedusiri offers incense and libation to ibis-headed Thoth, and food to ape-headed Thoth, id. *Tombeau*, ii, pp. 6-7, cf. i, p. 47; names of divinities, id. op. cit. in *Ann. Serv.* xx. 60.

(22)-(24) Top register destroyed. Second and third registers, Pedusiri offers incense to Osiris, and linen to Isis, id. *Tombeau*, ii, pp. 7-8, cf. i, pp. 47-8; names of offerings, and of Isis and King, id. op. cit. in *Ann. Serv.* xx. 60.

Pronaos.

(26) Titles of Pedusiri, id. *Tombeau*, ii, p. 8, cf. i, p. 49.

(26 bis) Pedusiri and friend playing draughts; text, id. ib. ii, p. 9, cf. i, p. 50; id. op. cit. in *Ann. Serv.* xx. 61.

(27)-(28), (30)-(32) On one side four registers jewellers, and on other side two registers jewellers and metal-workers, id. *Tombeau*, iii, pls. vii-ix; ii, pp. 9-12, cf. i, pp. 51-2, 52-4; some texts, id. op. cit. in *Ann. Serv.* xx. 65-7.

(29), (33), (38), (42) Titles of Pedusiri, id. *Tombeau*, ii, pp. 10, 12, 14, 15.

(33 bis), (42 bis) Jambs; titles of Pedusiri, id. ib. ii, pp. 12, 15, cf. i, pp. 55, 59.

(34) Pilaster. One column titles of Pedusiri, id. ib. ii, p. 12, cf. i, p. 55.

(34 bis) Pilaster. Pedusiri and friend playing draughts; texts, id. ib. ii, p. 13, cf. i, pp. 55-6.

(35)-(37) and (39)-(41) Four registers in each, incense-makers and carpenters, id. ib. iii, pls. x, xi; ii, pp. 13-15, cf. i, pp. 56-9; texts of incense-makers, id. op. cit. in *Ann. Serv.* xx. 68.

(43)-(46) Top register destroyed. Second and third registers, tending cattle, fourth register, vintage, id. *Tombeau*, iii, pl. xii; ii, pp. 16-19, cf. i, pp. 59-67; some texts, id. op. cit. in *Ann. Serv.* xx. 75-8.

(47)-(52) Top register destroyed. Second to fourth registers, agriculture, id. *Tombeau*, iii, pls. xiii-xv; ii, pp. 20-6, cf. i, pp. 67-79; text, id. *Légendes de scènes agricoles au tombeau de Petosiris* in *Rec. d'Études Égyptologiques dédiées à la Mémoire de Champollion*, pp. 86-92; reapers from second register, WRESZINSKI, op. cit. pl. 17; winnowing scene and men with laden asses from second and third registers, LEFEBVRE, op. cit. in *Ann. Serv.* xx, pl. iii; some texts, id. ib. pp. 71-4.

(53) and (54) Jambs; offering-texts, id. *Tombeau*, ii, pp. 26-7, cf. i, pp. 109-10; part of text of right jamb, id. op. cit. in *Ann. Serv.* xx. 85.



(55) Thickness; text of Seshu , father of Pedusiri, id. *Tombeau*, iii, pl. lviii [1 right]; ii, p. 27, cf. i, pp. 110-12; id. op. cit. in *Ann. Serv.* xxi. 152, cf. xxii. 46.

(56) Thickness; son Dhutrêkh  and text, id. *Tombeau*, iii, pl. xxiii [1]; ii, pp. 27-8, cf. i, pp. 113-17; text, id. op. cit. in *Ann. Serv.* xxi. 41, cf. xx. 87.

(57) Thickness; text of Zedhufef 'onkh , brother of Pedusiri, id. *Tombeau*, ii, pp. 28-9, cf. i, p. 117; id. op. cit. in *Ann. Serv.* xx. 86.



(58) Top register destroyed. Second register, three daughters before Pedusiri and wife, id. *Tombeau*, iii, pls. xvi [upper], xvii; ii, pp. 29-31, cf. i, pp. 84-90; text of second daughter Tehen , id. op. cit. in *Ann. Serv.* xx. 110 [bottom], cf. 80. Base; relations before tomb and scene of sacrifice in Greek style, id. *Tombeau*, iii, pls. xix, xxii [2], cf. i, pp. 90-4; id. *Un bas-relief grec dans un tombeau égyptien* in *Mon. Piot*, vol. xxv, pl. xvii, pp. 211, 215, figs. 2, 3; CAPART, *Impressions de Voyage* in *Chronique d'Égypte*, July 1927, plate opposite p. 115; PICARD, *Les influences étrangères au tombeau de Petosiris* [&c.] in *Bull. Inst. Fr. Arch. Or.* xxx, pl. i, cf. pp. 206, 209, figs. 1, 2; part, GARDNER in Ross, *The Art of Egypt through the Ages*, p. 235 [2].

(59) Biographical text of Pedusiri, LEFEBVRE, *Tombeau*, ii, p. 32, cf. i, pp. 79-81; id. op. cit. in *Ann. Serv.* xxii. 34.

(60)-(61) Top register, hymn, second register, son Zehō  and grandson Pedekem  before Pedusiri and wife, id. *Tombeau*, iii, pls. xxii [1], xvi [lower], xviii; ii, pp. 33-7, cf. i, pp. 94-107; texts of second register at (61), id. op. cit. in *Ann. Serv.* xx. 81, xxi. 138, 140, xxii. 140, 142, 147, 149-50, 152-3. Base; men and women bringing floral vase, animals, and flowers, to wife (?) of Pedusiri standing by tree, id. *Tombeau*, iii, pls. xx, xxi.

(62) Biographical text of Pedusiri, id. ib. ii, pp. 38-9, cf. i, pp. 81-3; id. op. cit. in *Ann. Serv.* xxii. 41.

Sanctuary.

East half dedicated to Seshu , father of Pedusiri, west half to Zedḥutef'onkh , brother of Pedusiri.

(63) Jamb; text of Zedḥutef'onkh, LEFEBVRE, *Tombeau*, iii, pl. xxiv [1]; ii, pp. 39-40, cf. i, pp. 167-9.

(64) Two columns religious text, id. ib. ii, p. 40.

(65) Upper register, Zedḥutef'onkh and Pedusiri with altar between them, lower register, Pedusiri before Zedḥutef'onkh, id. ib. iii, pl. xxv [2]; ii, pp. 40-1, cf. i, pp. 169-71; texts, id. op. cit. in *Ann. Serv.* xxi. 146, 147. Base; men in canoes with cattle crossing water, and fowl in papyrus-swamp, id. *Tombeau*, iii, pl. xxvii, cf. xxv [2 bottom]; i, p. 171.

(66) Jamb; hymn of Seshu to Osiris, id. ib. ii, pp. 41-2, cf. i, pp. 120-3, iv, pl. xxiv [2].

(67) Two columns Pyramid-Text, id. ib. ii, p. 43, cf. i, p. 123.

(68)-(69) Two registers Seshu and wife with children before Nut in tree, and Pedusiri before Seshu, id. ib. iii, pl. xxv [1]; ii, pp. 43-5, cf. i, pp. 124-7; part of text of Seshu from second register, id. op. cit. in *Ann. Serv.* xx. 91. Base; cattle and fowl in papyrus-swamp, id. *Tombeau*, iii, pl. xxvi, cf. xxv [1 bottom].

(70)-(80) Upper register, Zedḥutef'onkh adores Osiris, is conducted to Osiris, and adores bull-standards, uraei, hours, and apes, lower register, offering-scenes and chapter xviii of the Book of the Dead, id. ib. iii, pls. xxxix-xlv; ii, pp. 45-53, cf. i, pp. 172-80; some texts, id. op. cit. in *Ann. Serv.* xx. 97-9. Base; procession of male and female offering-bringers with animals, vases, flowers, &c., id. *Tombeau*, iii, pls. xlvii-xlix, cf. i, pp. 180-3; men and women (one carrying child) leading gazelle, &c., PICARD, op. cit. in *Bull. Inst. Fr. Arch. Or.* xxx, pl. ii (reversed), cf. p. 216; two women and two men, LEFEBVRE, op. cit. in *Ann. Serv.* xx, pl. iv; man with birds in basket, KEIMER, *Quelques hiéroglyphes représentant des oiseaux* in ib. xxx, p. 6, fig. 6.

(81)-(82) Upper register, servants, daughters, genii, priests, and grandson Zehō offering before mummy of Seshu in front of tomb, with text of Opening the Mouth, &c., and speeches of offerers above, lower register, funeral procession and biographical text above, LEFEBVRE, *Tombeau*, iii, pls. xxviii-xxxiv; ii, pp. 53-64, cf. i, pp. 128-45; text of Opening the Mouth from upper register, and texts of priests in funeral procession from lower register, id. op. cit. in *Ann. Serv.* xx. 219-22, 215, 218; names of daughters and servants, id. ib. 232; biographical text of Pedusiri from lower register, id. ib. xxi. 223, 224, 227, 229, 231-4, 238-9, 242; part, id. ib. xx. 55, 118; small texts of scenes in both registers, id. ib. 92-5. Base; male and female offering-bringers with animals, fowl, flowers, &c., id. *Tombeau*, iii, pls. xxxv, xxxvi, cf. i, pp. 145-8.

(83)-(86) Upper register, Seshu before nine genii, lower register, Zedḥutef'onkh and family before Seshu, id. ib. iii, pl. xxxvii; ii, pp. 65-7, cf. i, pp. 151-2; part of texts, id. op. cit. in *Ann. Serv.* xx. 95-6. Base; men driving cattle, and fowl in papyrus-swamp, id. *Tombeau*, iii, pl. xxxviii.

- (87) Two columns text of Seshu, id. ib. ii, p. 67, cf. i, pp. 148-9.
- (88)-(89) Seshu before Atum, Serḳi, and Horus, with offering-text below, id. ib. iii, pl. liv [1]; ii, pp. 68-9, cf. i, pp. 149-50; text below, id. op. cit. in *Ann. Serv.* xxi. 48-9.
- (90) Two columns titles of Seshu, id. *Tombeau*, ii, p. 69, cf. i, p. 151.
- (91)-(99) Top register, double scene, Seshu adores Osiris and Isis, and Zedḥutef'onkh adores Osiris and Nephthys, second register, scarab adored by winged Buto and Nekhbet on each side followed by figure of Isis, id. ib. iii, pls. lii, liii; ii, pp. 69-72 [91-6], cf. i, pp. 197-200; top register, texts of Seshu, Osiris, and Isis, id. op. cit. in *Ann. Serv.* xx. 88. Base; enigmatic text between emblems, with Seshu and Zedḥutef'onkh as *ka*-servants offering libation to *ba*-bird on either side, id. *Tombeau*, iii, pl. lii [bottom]; ii, p. 73 [97-9], cf. i, pp. 200-1.
- (100) Two columns titles of Zedḥutef'onkh, id. ib. ii, pp. 73-4, cf. i, pp. 183-4.
- (101)-(102) Zedḥutef'onkh before gods 'Ankh (?), Thesy, and Demez, with six columns text below, id. ib. iii, pl. liv [2]; ii, pp. 74-5, cf. i, pp. 184-5; text below, id. op. cit. in *Ann. Serv.* xx. 101, cf. xxi. 246.
- (103) Two columns text of Zedḥutef'onkh, id. *Tombeau*, ii, p. 75, cf. i, pp. 185-6.
- (104)-(106) Two registers, Zedḥutef'onkh adores Ennead, and Pedusiri before Zedḥutef'onkh, id. ib. iii, pl. 1; ii, pp. 75-7, cf. i, pp. 186-8; text of Pedusiri, id. op. cit. in *Ann. Serv.* xx. 100. Base; hippopotami, crocodiles, and birds in swamp with marsh-plants, id. *Tombeau*, iii, pl. li, cf. i, p. 188.
- Pillars.
- (107)-(110), (111)-(114) Four registers on each, with Seshu before two divinities; texts, id. ib. ii, pp. 77-82, cf. i, pp. 153-6.
- (115) Prayer of Seshu to Thoth, id. ib. ii, p. 82, cf. i, pp. 156-8; id. op. cit. in *Ann. Serv.* xxi. 154-5.
- (116) Offering-text and speech of Seshu, id. *Tombeau*, iii, pl. lv [2]; ii, p. 83, cf. i, pp. 158-60; id. op. cit. in *Ann. Serv.* xxi. 158.
- (117)-(120), (121)-(124) Four registers on each, with Zedḥutef'onkh before two divinities; texts, id. *Tombeau*, ii, pp. 84-8, cf. i, pp. 188-91.
- (125) Offering-text of Zedḥutef'onkh, id. ib. iii, pl. xxiii [3]; ii, pp. 88-9, cf. i, pp. 191-2; id. op. cit. in *Ann. Serv.* xxi. 50-1.
- (126) Six columns speech of Zedḥutef'onkh, id. *Tombeau*, ii, pp. 89-90, cf. i, pp. 192-3; id. op. cit. in *Ann. Serv.* xxi. 149.
- (127) Six columns speech of Seshu, id. *Tombeau*, iii, pl. lvi [1]; ii, pp. 90-1, cf. i, pp. 161-2.
- (128) Six columns titles of Seshu, id. ib. ii, p. 91, cf. i, pp. 162-3.
- (129)-(132), (133)-(136) Four registers on each, Seshu before destroyed god, Horus Khentenmerty, Shu, and Tefnut, and before destroyed god, Khepri, Imset, and Anubis; texts, id. ib. ii, pp. 92-4, cf. i, pp. 164-5.
- (137) Six columns speech of Zedḥutef'onkh, id. ib. iii, pl. lvi [2]; ii, p. 95, cf. i, pp. 193-4; id. op. cit. in *Ann. Serv.* xxi. 52-3.
- (138) Six columns titles of Zedḥutef'onkh, id. *Tombeau*, iii, pl. lv [1]; ii, pp. 95-6, cf. i, pp. 194-5.
- (139)-(142) Four registers Zedḥutef'onkh before Atum, Osiris, Ḥapi, and Anubis, id. ib. iii, pl. xxiii [2]; ii, pp. 96-8, cf. i, pp. 195-6.
- (143)-(146) Four registers Zedḥutef'onkh before Ḳebḥsenuf, Geb, Ḥeka-ma-yotf, and Ir-renf-zesef; texts, id. ib. ii, pp. 98-9, cf. i, p. 196.

Sarcophagus Chambers.**Gallery.**

Sarcophagus of Pedusiri, left on spot; text on lid, id. ib. ii, p. 100 [147], cf. i, p. 201; see id. op. cit. in *Ann. Serv.* xx. 110. Wooden coffin, in Cairo Mus.; lid, id. *Tombeau*, iii, pl. lviii; ii, pp. 100-1 [148], cf. i, pp. 201-3; id. op. cit. in *Ann. Serv.* xx. 209-10, cf. 112-13.

Sarcophagus of Renpetnefer(t) $\left\{ \begin{array}{l} \text{☉} \\ \text{†} \\ \text{☉} \end{array} \right.$, wife of Pedusiri, left on spot; text on lid, id. *Tombeau*, ii, p. 101 [149], cf. i, p. 203; id. op. cit. in *Ann. Serv.* xx. 110 [top].

Wooden coffin of Dḥutrēkh $\begin{array}{c} \text{☉} \\ \text{☉} \end{array}$, son of Pedusiri, id. *Tombeau*, ii, pp. 102-3 [151-2], cf. i, pp. 204-5; tiles from text on lid, id. op. cit. in *Ann. Serv.* xx. 114.

Fragment of sarcophagus, probably of Zedḥutef'onkh $\begin{array}{c} \text{☉} \\ \text{☉} \end{array}$, brother of Pedusiri, in Turin Mus.; text, id. ib. 211, cf. 212.

North Room.

Fragment of sarcophagus, name unknown, left on spot; text, id. *Tombeau*, ii, p. 101 [150], cf. i, p. 203; id. op. cit. in *Ann. Serv.* xx. 109.

TOMB OF PEDEKAKEM $\begin{array}{c} \text{☉} \\ \text{☉} \end{array}$, Royal scribe of accounts of P-mek in the Hermopolite nome; Prophet of the living cat of the Temple of Pa'kht; &c.; and his father Dḥutey $\begin{array}{c} \text{☉} \\ \text{☉} \end{array}$, with same titles; relations of Pedusiri. East of last.

See GABRA, *Rapport préliminaire sur les fouilles de l'Université Égyptienne à Touna (Hermopolis Ouest)* in *Ann. Serv.* xxxii. 72-7. Plan, id. ib. p. 73, fig. 8, cf. p. 58, fig. 1; names of P-mek (cemetery of Hermopolis) and of deceased, JUNKER, *Wissenschaftliche Unternehmungen in Ägypten und Nubien 1930-1* in *Mitteil. d. Deutsch. Inst. Kairo*, ii, p. 147.

Sepulchral Chamber.

Lids of coffins of Pedekakem and Dḥutey; texts, GABRA, op. cit. 74, 75-6.

Finds.

Black granite statue of Pkhar $\begin{array}{c} \text{☉} \\ \text{☉} \end{array}$, Scribe of the correspondence of Pharaoh, Saite, found in débris, id. ib. pl. iii [upper] and p. 77.

LATE TOMB. 1st century B.C. South of Tomb of Pedusiri.

Plan showing position, id. ib. p. 58, fig. 1 [A]. Views of façade, id. ib. pl. i and p. 39, fig. 2, cf. pp. 59-63.

TOMB OF ISIDORA. Temp. Antoninus Pius. East of last.

See id. ib. pp. 66-8 with fig. 6, and p. 58, fig. 1 [B].

Finds from various tombs.



Fragments of temple of Amenophis IV, re-used in New Kingdom tombs, now in Cairo Mus., see WEILL, op. cit. in *Comptes Rendus* (1912), 486-7; id. op. cit. in *Mon. Piot*, vol. xxv, p. 420.

Granite sarcophagus of Dḥutmosi $\begin{array}{c} \text{☉} \\ \text{☉} \end{array}$, Royal scribe, Overseer of cattle, Dyn. XIX, in Cairo Mus.; texts, DARESSY, *Un sarcophage de Tounah* in *Ann. Serv.* xvi. 116-20.

Granite sarcophagus of Neshuy $\begin{array}{c} \text{☉} \\ \text{☉} \end{array}$, Chief priestess of Thoth, temp. Ramesses II, in Louvre E. 11297; name, WEILL, op. cit. in *Mon. Piot*, vol. xxv, pp. 421, 423 [right]; see id. op. cit. in *Comptes Rendus* (1912), 487.

Ushabtis found in tomb of Neshuy, including names of Unnūfer, Wenamūn, Hai, and Ḍhutmosi (probably Ḍhutmosi, Overseer of cattle, see supra, p. 174); ushabtis of Ḍhutmosi, one in the Louvre, id. op. cit. in *Mon. Piot*, vol. xxv, pl. xxix [1-3, 5], and pp. 426-8, cf. 424-5.

Other ushabtis of Ḍhutmosi, two of sandstone, and some of alabaster, bought at Tūna and Mallawi, id. ib. p. 434, figs. 4, 5, and p. 431, cf. pp. 433-6.

Wooden box of Ay , Overseer of horses, (afterwards King), and Teye , probably from here, in Berlin Mus. 17555; texts, *Aeg. Inschr. Mus. Berlin*, ii. 267-8.

Fragment of black granite sarcophagus of a high priest of Thoth with many interesting titles, Saite (?); text, DARESSY, *Notes et Remarques* in *Rec. de Trav.* xx. 86 [clxv].

Limestone sarcophagus of Aḥmosi , High priest of Thoth, Saite, found in a tomb six kilometres north of Tomb of Pedusiri, in Cairo Mus., GABRA, *Un sarcophage de Touna* in *Ann. Serv.* xxviii, pp. 66-79; see ABOU SEÏF, *Rapport sur deux sarcophages découverts à Touna el-Gebel* in ib. pp. 61-4.

Limestone sarcophagus of Ḍhutardais , High priest of Thoth, Saite, in Cairo Mus.; texts, WEILL, *Monuments égyptiens divers* in *Rec. de Trav.* xxxvi. 92; see MASPERO, *Guide* (1914), pp. 252-3. Ushabti, WEILL, op. cit. pl. vi [1], p. 91.

Lid of limestone sarcophagus of Tadepakem , probably relation of Pedusiri, found in a tomb, now in Cairo Mus.; texts, LEFEBVRE, *Un couvercle de sarcophage de Tounah* in *Ann. Serv.* xxiii. 229-45.

Red granite naos of Nektanebos II (Nekht-ḥar-ḥebi), found in débris of destroyed brick building on desert-edge, in Cairo Mus. 70014, BORCHARDT and REISNER, *Works of Art*, 50; ROEDER, *Naos* (Cat. Caire), pl. 11 [b], p. 46; MASPERO and ROEDER, *Führer* (1912), pl. 41; texts, CHABÂN, *Fouilles à Achmounéin* in *Ann. Serv.* viii. 222.

Fragment of stela with ibises of a priest of Thoth, bought at Tūna, KEIMER, *Ein Stelen-Fragment aus Tuna* in *Mitteil. d. Deutsch. Inst. Kairo*, ii, pl. xxxiv [a], p. 139.

MALLAWI

Black basalt monolithic naos, with pyramidal top and two vertical lines of text, dug up in a street by JOMARD, *Descr. de l'Égypte, Ant.* iv, pl. 67 [2-4], cf. *Texte*, iv. 317-19.

EAST BANK

EL-SHEIKH 'IBĀDA (ANTINOË or ANTINOUPOLIS)

Plans of site, *Descr. de l'Égypte, Ant.* iv, pls. 53, 54 [lower], cf. *Texte*, iv, p. 209 et seq.; GAYET, *L'Exploration des nécropoles gréco-byzantines d'Antinoë* in *Ann. Mus. Guimet*, xxx, 2^{me} partie, pl. xx; of Town Enclosure, JOHNSON, *Antinoë and its Papyri* in *J.E.A.* i, p. 173, cf. pl. xxii. View, *Descr. de l'Égypte, Ant.* iv, pl. 54 [upper]. Description, BONOMI MSS.* *Diary*, Jan. 15, 1825; SAINT-FERRIOL MSS.* *Diary*, Jan. 27, 1842.

CHAPEL OF AMENOPHIS IV. North of Temple of Ramesses II.

Damaged cartouche and fragment of text of Amenophis IV; text, GAYET, *Compte Rendu des Fouilles* [&c.] in *Ann. Mus. Guimet*, xxvi, 3^{me} partie, 55.

TEMPLE OF RAMESSES II. West of Town Enclosure. (See plan, supra p. 170.)

GAYET, *L'Exploration des ruines d'Antinoë et la découverte d'un temple de Ramsès II* in ib. 19-48. Plan, id. ib. 18. Views, id. *Antinoë et les Sépultures de Thais et Sérapion*, pp. 3, 7; JOHNSON, op. cit. in *J.E.A.* i, pl. xxiii [4]; of columns 1-3, 9, 10, id. ib. pl. xxiv.

Court.

Columns.

(1) Two scenes, King offers lotuses to Thoth, and incense and libation to the 'Noble of Hermopolis', GAYET, *L'Exploration des ruines d'Antinoë* [&c.] in *Ann. Mus. Guimet*, xxvi, 3^{me} partie, pl. i, cf. pp. 25-6.

(2) Three scenes (top destroyed), King before god, before goddess, and offers libation to Osiris, id. ib. pl. ii, cf. pp. 26-7.

(3) Three scenes, King before Khnum, before Ḥathor, and offers wine to Khnum, id. ib. pl. iii, cf. pp. 28-9.

(4) Three scenes, King offers wine to Thoth, eye-paint to Ḥathor, and eye-paint to Thoth, id. ib. pl. iv, cf. pp. 29-30.

(5) Three scenes, King offers ointment to Sokari, four vases to Isis, and lustration to Sokari-Osiris, id. ib. pl. v, cf. pp. 30-1.

(6) Three scenes, King offers incense to the 'Noble of Hermopolis', offerings to Pa'kht, and incense to the 'Noble of Hermopolis', id. ib. pl. vi, cf. pp. 32-3.

(7) Three scenes (top destroyed), King offers bread to god, King before goddess, and offers bread to god, id. ib. pl. vii, cf. p. 33.

(8) Three scenes, King offers image of Ma'et to Rē'-Ḥarakhti, incense to Mut, and wine to Rē'-Ḥarakhti, id. ib. pl. viii, cf. p. 34.

(9) Two scenes, King offers incense (?) to Rē'-Ḥarakhti, and to Atum, id. ib. pl. ix, cf. pp. 35-6.

(10) Three scenes, King offers bread to Ptaḥ, to Sekhmet, and to Ptaḥ, id. ib. pl. x, cf. pp. 36-8.

(11) Two scenes, King receives life from Khepri, and offers lotuses to Nephthys, id. ib. pl. xi, cf. pp. 38-9.

(12) Three scenes, King offers eye-paint to the 'Noble of Hermopolis', offerings to Ḥathor, and eye-paint to the 'Noble of Hermopolis', id. ib. pl. xii, cf. pp. 39-40.

(13) Three scenes, King offers bread to Thoth, to Neḥem'awat, and to Thoth, id. ib. pl. xiii, cf. pp. 41-2.

(14) Three scenes, King offers wine to Atum, to Ḥathor, and to Atum, id. ib. pl. xiv, cf. pp. 42-3.

Hypostyle.

Columns.

(15) King offers incense to Thoth and Neḥem'awat, id. ib. pl. xv, cf. pp. 44-5.

(16) King offers wine to Khnum and Ḥathor, id. ib. pl. xvi, cf. pp. 45-6.

(17) King offers incense to Amen-rē' and Mut, id. ib. pl. xvii, cf. pp. 46-7.

(18) King offers wine to Rē'-Ḥarakhti, and Ius'as, id. ib. pl. xviii, cf. pp. 47-8.

TEMPLE OF ISIS. Roman. In east part of Town Enclosure.

Views, GAYET, *Antinoë et les sépultures de Thaïs et Sérapion*, pp. 9, 11, 13.

Head of granite statue of Isis, found in ruins, id. op. cit. in *Ann. Mus. Guimet*, xxvi, 3^{me} partie, pl. xix, cf. p. 56.

TEMPLE OF SERAPIS (?). In north-east part of Town Enclosure.

See id. ib. p. 56.

NECROPOLIS. Middle Kingdom and Graeco-Byzantine.

East of Town Enclosure.

See id. ib. pp. 56-8, 59-62, pls. xx-xxv.

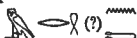
Sarcophagi of Mer-shent (?) , Intimate, in Brussels, Musées Royaux du

Cinquantenaire, E. 785, of Pautemḥēt  Unique royal ornament, and another (no name), all Middle Kingdom; texts, id. op. cit. in *Ann. Mus. Guimet*, xxx, 2^{me} partie, 41-5; texts of Mer-shent, SPELEERS, *Rec. des Inscr. Ég.* 19 [82]; part of texts of Pautemḥēt, CAPART, *Miscellen* in *Ä.Z.* xlii. 144.

Stela of Pêre , Head of the serfs, Ramesside, in Munich Antiquarium 39, DYROFF and PÖRTNER, *Aegyptische Grabsteine und Denksteine aus süddeutschen Sammlungen*, ii, pl. xii [18], cf. pp. 25-7.

DEIR EL-BERSHA

Map of site, GRIFFITH and NEWBERRY, *El Bersheh*, ii, pl. ii.

GREAT ROCK-TOMBS.¹ Dyn. XII. North side of valley.

Complete, id. ib. vols. i and ii. Plan, id. ib. ii, pl. iii. Description, BONOMI MSS.* Diary, July 1, 1831.

Upper Tombs.

I. DHUTINAKHT VI , Nomarch of the Hare-nome. (Destroyed by earthquake.)

GRIFFITH and NEWBERRY, op. cit. ii, pp. 17-26, frontispiece and pls. iv-ix. Plan, section, and elevation, id. ib. pl. iv.

Hall.

Fragment probably from entrance wall, id. ib. pl. ix [9], cf. p. 18.

(1) Deceased (destroyed) watching five registers, hunting, dragging sledge, towing funeral boat, boating, fishing and hippopotamus-hunt; texts, id. ib. pp. 19-20; fragments from second and third registers, id. ib. pl. ix [8, 10], cf. p. 18; sailing-boat (presumably from here), WILKINSON MSS.* xii. 26 [lower].

(2) Deceased and wife harpooning fish, and text above; texts, GRIFFITH and NEWBERRY, op. cit. ii, pl. vii [upper], and p. 23.

(3) Vizier and wife receiving offerings, and stone-masons below; texts, id. ib. p. 24.

(4) Remains of scene of table and offering-list before deceased and wife, with harvest below, id. ib. frontispiece and pl. ix [1-7], cf. pp. 20-2; fragment from offering-list, kneeling men holding drinking vessels [= frontispiece and pl. ix (1)], in Brit. Mus. 1151, *Hiero. Texts* [&c.], Pt. v, pl. 9; see *Guide, Sculpture* (1909), pp. 60-1 [200].

(5) Remains of three registers agricultural scenes before deceased with attendants, GRIFFITH and NEWBERRY, op. cit. ii, pl. viii, cf. v [lower] and pp. 21-2; fragment of ploughing and sowing [= pl. viii (12)], in Brit. Mus. 1152, *Hiero. Texts* [&c.], Pt. v, pl. 8; see *Guide, Sculpture* (1909), p. 60 [199].

(4)-(5) Remains of frieze-text, GRIFFITH and NEWBERRY, op. cit. ii, p. 21, cf. pl. viii [1-3]; for the dates on fragments [= pls. viii and ix], see MEYER, *Nachträge zur Aegyptischen Chronologie* in *Abhand. d. K. Akad. d. Wiss.* (Phil. Hist. Kl.), 1907, p. 18.

Ceiling. Fragments of text, GRIFFITH and NEWBERRY, op. cit. ii, pl. vi. Decoration, id. ib. pl. v [top right].

Entrance to Shrine.

(6)-(7) Lintel and jambs, id. ib. pl. vii [lower], cf. pp. 24-5.

Shrine.

(8) and (9) Offering-scenes before deceased and wife; texts, id. ib. pp. 25-6 [left].

¹ The marginal tomb-numbers are those of GRIFFITH and NEWBERRY.

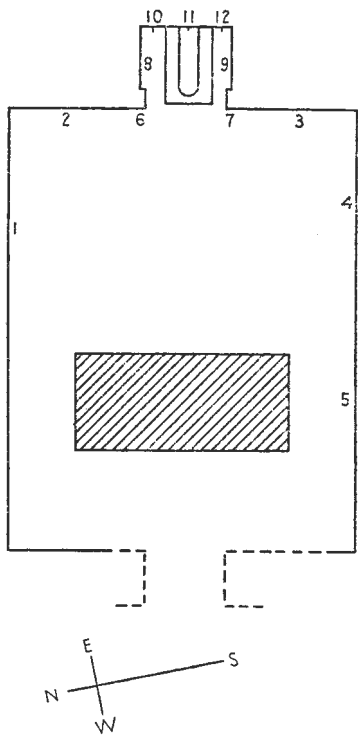

Tomb 1. D̥utinakht VI. From GRIFFITH and NEWBERRY, *El Bersheh*, ii, pl. iv.

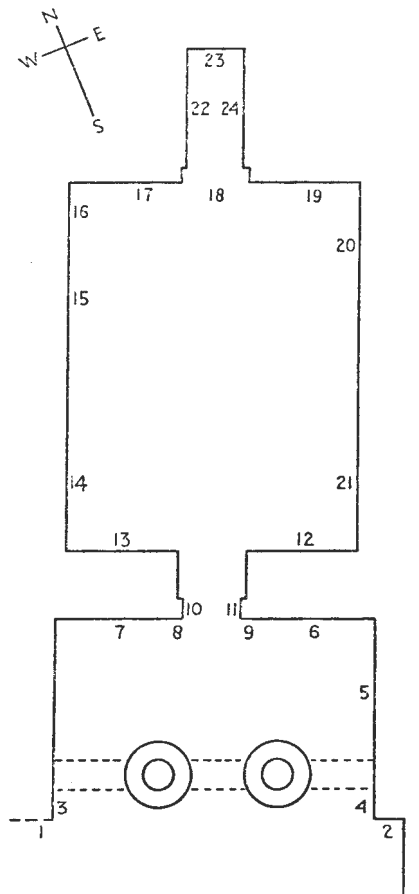

Tomb 2. D̥utihotp II. From NEWBERRY, *El Bersheh*, i, pl. ii.

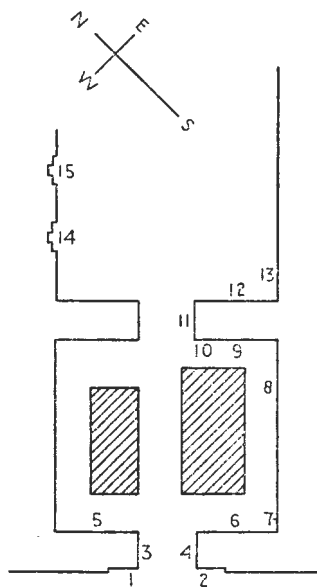

Tomb 5. 'Ahanakht. From GRIFFITH and NEWBERRY, *El Bersheh*, ii, pl. xii.

(10)–(12) Four rows of offering-bringers on either side of statue of deceased; titles above offering-bringers, id. ib. p. 26 [right].

Sarcophagus Chamber.

Plan, DUNHAM, *The Tomb of Dehuti-Nekht and his Wife* in *Boston Mus. Bull.* Aug. 1921, p. 44.

Painted coffins and models of boats, &c., in Boston Mus., id. ib. figs. on pp. 43, 44, 46; detail from coffin-lid, *Handbook* (1930), p. 19.

2. DḤUTIḤOTP II , Nomarch of the Hare-nome. Temp. Sesostris II and Sesostris III.

Complete, GRIFFITH and NEWBERRY, *El Bersheh*, i, passim. Plan, section, and elevation, id. ib. pls. ii–iv; plan and sections showing scenes, HAY*, 29814, 3–7; plan, L. D. i. 66 [top left], and *Text*, ii, p. 116; NESTOR L'HÔTE MSS.* 20396, 265 verso [bottom right]. Description, id. ib. 264 verso–267; SAINT-FERRIOL MSS.* *Diary*, May 11, 1842.

Façade (destroyed).

View showing destruction by earthquake, WRZSZINSKI, *Bericht über die photographische Expedition* [&c.], pl. 18 [A].

(1)–(2), (3), (4) Jambs and outer thicknesses; texts, GRIFFITH and NEWBERRY, op. cit. i, pl. v [upper]; of east jamb and thickness, L. D. ii. 135 g, and *Text*, ii, p. 116 [a, b]; parts, NESTOR L'HÔTE MSS.* 20396, 249, 264 [bottom], 265 verso [bottom left]; WILKINSON MSS.* iii. 7 [right]. Architrave; texts, GRIFFITH and NEWBERRY, op. cit. i, pl. v [lower].

Portico.

(5) Hunting and netting wild animals before deceased, id. ib. pl. vii; texts of deceased and sons, L. D. *Text*, ii, p. 117 [top]; first line of text above deceased, WILKINSON MSS.* iii. 7 [near right]; deceased, L. D. ii. 134 e; NESTOR L'HÔTE MSS.* 20396, 266.

(6) Deceased and family fowling, with boatmen fighting and offering-bringers below, GRIFFITH and NEWBERRY, op. cit. i, pl. viii; NESTOR L'HÔTE MSS.* 20396, 266 verso; upper part of deceased and sons, id. *Lettres écrites d'Égypte*, 48.

(7) Deceased and family spearing fish, and men fishing in canoes below, GRIFFITH and NEWBERRY, op. cit. i, pl. ix [left]; text above deceased, L. D. *Text*, ii, p. 117 a; names of sons behind deceased, WILKINSON MSS.* iii. 7 [middle right].

Entrance to Hall.

(8)–(9) Lintel and jambs with remains of text and figures of deceased, GRIFFITH and NEWBERRY, op. cit. i, pl. ix [right].

(10) and (11) Thicknesses; name and titles of deceased, id. ib. p. 15; L. D. *Text*, ii, p. 117 [right lower]; NESTOR L'HÔTE, *Lettres écrites d'Égypte*, 47 [upper]; id. MSS.* 20396, 264 verso; WILKINSON MSS.* iii. 7 [middle left].

Ceiling. Text, GRIFFITH and NEWBERRY, op. cit. i, pl. vi [A].

Hall.

(12) Deceased purified by four sons, with lector and three servants behind deceased, id. ib. pl. x and p. 16 (omitting one son); BLACKMAN, *Some Notes on the Ancient Egyptian Practice* [&c.] in *J.E.A.* v, pl. xviii opposite p. 117 (from NEWBERRY); sketch (showing four sons), NESTOR L'HÔTE MSS.* 20396, 255, 267; omitting figures to right of deceased, WILKINSON MSS.* iii. 6 [right], xii. 26 [upper]; view of wall, DAVIES, *Archaeological Survey* in *Archaeological Report* (1899–1900), frontispiece.

(13) Deceased followed by sons with priests performing ceremonies, GRIFFITH and NEWBERRY, op. cit. i, pl. xi.

(14)-(15) Upper part. Deceased, followed by attendants with twelve columns text before him, watches transport of colossus, id. ib. pls. xii [upper left and middle], xiii-xv; omitting deceased and attendants, NESTOR L'HÔTE MSS.* 20404, 16, 25, 20396, 254; first seven columns of long text, id. ib. 20409, Q, 'Tombeaux de Berscheh 2' (squeeze); first two columns, WILKINSON MSS.* xii. 24 [right]-25 [right]; titles (destroyed) in front of deceased, L. D. *Text*, ii, p. 119 [top middle]; GRIFFITH and NEWBERRY, op. cit. i, p. 17; transport of colossus, WILKINSON MSS.* iii. 5 verso, 8, 8 verso [left]; scene copied by BANKES probably about 1820, in possession of the family at Kingston Lacey, near Wimborne, Dorset; scene omitting texts, ROSELLINI, *Mon. Civ.* xlvi [1]; MINUTOLI, *Reise zum Tempel des Jupiter Ammon*, xiii; CAILLIAUD, *Arts et Métiers*, pl. 43 (called Beni Ḥasan); WILKINSON, *M. and C.* iii. 328 (No. 390) = ed. BIRCH, ii. 305 (No. 429); sketch of scene with some texts, HAY*, 29814, 8; BURTON MSS.* 25636, 18; man with stick from bottom register behind colossus, PRISSE, *L'Art Égyptien*, ii, *Dessin*, pl. i [2] 'Ancien Canon des Proportions [&c.]', cf. *Texte*, p. 394.

(14)-(16) Lower part. Men netting fish and deceased with wife netting fowl, and four registers boats towing dahabiya, and stock-taking of cattle before deceased, GRIFFITH and NEWBERRY, op. cit. i, pls. xii [lower], xvii-xix; deceased at north end, L. D. ii. 134 b; WILKINSON MSS.* iii. 7 [lower left]; text of deceased, L. D. *Text*, ii, p. 118 a; text of wife in fowling scene, id. ib. p. 119 a; column of kiosk (text inaccurate), PRISSE, *L'Art Égyptien*, i, *Architecture*, pl. 20 [upper left] 'Détails de colonnettes en bois', cf. *Texte*, p. 363.

(16) Upper part. Gateway to temple, and remains of figures outside (almost destroyed), GRIFFITH and NEWBERRY, op. cit. i, pls. xii [upper right], xvi; gateway, L. D. ii. 135 a-d, cf. *Text*, ii, p. 118 [middle lower]; NESTOR L'HÔTE MSS.* 20396, 253, 20409, P, 'Tombeaux de Berscheh 2' (squeeze); sketch, WILKINSON MSS.* iii. 8 verso [right]. (The jambs of the gateway, cut away about 1888, are now in Florence Museum, see GRIFFITH and NEWBERRY, op. cit. i, p. 22, note 5.)

(17)-(18) Top register, deceased and son (above door) netting fowl, with wife standing by net, id. ib. pls. xx [top left and middle], xxi; name of son, L. D. *Text*, ii, p. 118 [middle upper].

(17) Second register, netting fish, third register, three rows feeding, cooking, and bringing cranes, geese, &c., GRIFFITH and NEWBERRY, op. cit. i, pls. xx [left lower], xxii, xxiii.

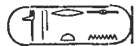
(19) Eight registers (top one destroyed) bringing fish and fowl to deceased and daughter, with servants behind, GRIFFITH and NEWBERRY, op. cit. i, pl. xx [right]; NESTOR L'HÔTE MSS.* 20396, 248, 256; deceased, and text of daughter, L. D. ii. 134 d, 135 f, and *Text*, ii, p. 118 [top]; man bringing fish to son Senusert-'ankh  †, from third register, WILKINSON MSS.* xii. 23 [lower].

(20)-(21) Remains of scenes of agriculture, potters, bread-making, gardening, vintage, and spinning and weaving, before deceased (destroyed) with female relations, GRIFFITH and NEWBERRY, op. cit. i, pls. xxiv-xxxi and frontispiece, cf. pp. 32-9; five registers, maize-harvest, potters, picking grapes and watering garden, female spinners, and female weavers, WILKINSON MSS.* iii. 6 [left]; texts of wife, daughters, &c., GRIFFITH and NEWBERRY, op. cit. i, p. 37; three daughters, in Cairo Mus., BISSING, *Denkmäler*, 35; sister, in Brit. Mus. 1150, see *Guide*, Sculpture (1909), p. 61 [201]; bottom register, men with shields, bow and arrows, palanquin, and dog, in Brit. Mus. 1147, *Hiero. Texts* [&c.], Pt. v, pl. 7; BLACKMAN in ROSS, *The Art of Egypt through the Ages*, p. 142 [2]; see *Guide*, Sculpture (1909), p. 60 [198].

Ceiling. Text, GRIFFITH and NEWBERRY, op. cit. i, pl. vi [B]; NESTOR L'HÔTE MSS.* 20396, 250.

Shrine.

(22) and (24) Funerary ritual and offering-bringers before deceased, GRIFFITH and NEWBERRY, op. cit. i, pls. xxxii, xxxiv; left wall, deceased before offerings, NESTOR L'HÔTE MSS.* 20396, 246 [upper right]; right wall, deceased before altar, id. ib. 246 [upper left], 247 [upper]; deceased, WILKINSON MSS.* xii. 25 [lower]; title, L. D. ii. 135 e, cf. *Text*, ii, p. 119 [middle lower].

(23) Deceased and father Kay $\text{𓆎} \text{𓆏} \text{𓆏}$, GRIFFITH and NEWBERRY, op. cit. i, pl. xxxiii; NESTOR L'HÔTE MSS.* 20396, 246 [lower], 247 [lower]; heads and text, L. D. ii. 134 c, and *Text*, ii, p. 119 [middle upper]; head of deceased, PRISSE, *L'Art Égyptien*, ii, *Sculpture*, pl. 29 [3] 'Types et Portraits', cf. *Texte*, p. 407.

Ceiling. Text, GRIFFITH and NEWBERRY, op. cit. i, pl. vi [c].

Fragment with name of Kay $\text{𓆎} \text{𓆏} \text{𓆏}$, from this tomb, found in tomb of Neferi $\text{𓆎} \text{𓆏} \text{𓆏}$, DARESSY, *Fouilles de Deir el Bircheh* in *Ann. Serv.* i. 42.

3. SEP $\text{𓆎} \text{𓆏} \text{𓆏}$, Nomarch of the Hare-nome; Vizier; Royal scribe.
(Destroyed.)

Plan and elevation of remains, GRIFFITH and NEWBERRY, *El Bersheh*, ii, pl. x [lower].

Entrance.

Fragment of lintel with titles of deceased, id. ib. p. 27.

Shrine.

Names of sons of Wazkaues $\text{𓆎} \text{𓆏} \text{𓆏}$, father of deceased, from offering-scene, id. ib. p. 28.

4. NEHERI I $\text{𓆎} \text{𓆏} \text{𓆏}$.

Plan, id. ib. pl. x [upper].

Hall.

Fragments from right and rear walls, including wrestling scene, id. ib. pl. xi, cf. p. 29.

5. 'AḤANAKHT $\text{𓆎} \text{𓆏} \text{𓆏}$, Governor of the city; Vizier; Nomarch of the Hare-nome.

Complete, id. ib. pls. xii-xvii, and pp. 30-5. Plan, sections, and elevation, id. ib. pl. xii.

Entrance (destroyed).

(1)-(2) Lintel and jambs; texts, id. ib. pl. xiii [top, left and right]; of lintel, MASPERO, *Note sur l'article de M. Sayce* in *Rec. de Trav.* xiii. 193; NESTOR L'HÔTE MSS.* 20396, 251 [lower]; part, L. D. *Text*, ii, p. 119 [near bottom].

(3) and (4) Thicknesses; remains of texts above seated figure of deceased, GRIFFITH and NEWBERRY, op. cit. ii, pl. xiii [middle], cf. p. 33.

Outer Hall.

(5) Deceased before offerings (destroyed), and three registers below, dancers, tending cows, and bulls fighting, id. ib. pl. xiv.

(6) Remains of scene of asses, men bringing fowl, and birds in pond, id. ib. pl. xv [right].

(7) and (8) Painted lotus-column, and remains of kneeling figures of offering-bringers with texts, id. ib. pl. xv [middle and left]; two lines offering-text beside column, L. D. *Text*, ii, p. 120 [top].

(9) Remains of four registers, mythological animals from hunting scene, men bringing fish, and netting fish, GRIFFITH and NEWBERRY, *op. cit.* ii, pl. xvi [right]; names of the animals, *L. D. Text*, ii, p. 119 [bottom].

Fragment of text probably from west wall, GRIFFITH and NEWBERRY, *op. cit.* ii, p. 34.

Entrance to Inner Hall.

(10) Jamb; deceased seated at bottom with remains of text above, *id. ib.* pl. xvi [bottom left].

(11) Thickness; deceased in panther-skin, *id. ib.* pl. xvi [top left].

Inner Hall.

(12) Upper part, deceased with four attendants greeted by two men with branches, lower part, two registers cattle; upper part, *id. ib.* pl. xvii [lower]; omitting two attendants, MASPERO, *op. cit.* in *Rec. de Trav.* xiii. 192 (from papers of NESTOR L'HÔTE); NESTOR L'HÔTE MSS.* 20396, 251 [upper].

(13) Remains of scene of offering-bringers before deceased, and papyrus-column in corner, GRIFFITH and NEWBERRY, *op. cit.* ii, pl. xvii [upper]; papyrus-column, *L. D. Text*, ii, p. 120 a.

(14) and (15) Lower part of two false doors; remains of texts with names of deceased and *D*ḥutinakht , GRIFFITH and NEWBERRY, *op. cit.* ii, p. 35.

6. *D*ḤUTINAKHT . (Destroyed.)

Block probably from lintel, *id. ib.* p. 36.



7. NEḤERI , Mayor; Great priest of Thoth. (Almost destroyed.)

Plan and section, *id. ib.* pl. xviii.

Hall.

Fragment of texts from ceiling, *id. ib.* pl. xix, cf. p. 37.

Lower Tombs. South-west of Tomb of 'Aḥanakht (No. 5).

8. 'AḤANAKHT , Nomarch of the Hare-nome, and IḤA , Overseer of the royal harīm (?).

Complete, GRIFFITH and NEWBERRY, *El Bersheh*, ii, pp. 38-41, pl. xxi, cf. Addendum, p. 46. Plan and elevation, *id. ib.* pl. xx.

Façade.

Lintel and jambs; texts, *id. ib.* pp. 38-9.

Hall.

South (entrance) wall. Remains of frieze-text, *id. ib.* p. 39 [middle].

West wall. Frieze-text, biographical text, and remains of false door (?), *id. ib.* pl. xxi [lower] and p. 39; SAYCE, *Gleanings from the Land of Egypt* in *Rec. de Trav.* xiii. 190-1.

North wall. Frieze-text of 'Aḥanakht, and inscription of Iḥa, GRIFFITH and NEWBERRY, *op. cit.* ii, pp. 40-1, pl. xxi [upper]; SAYCE, *op. cit.* 189.

East wall. Frieze-text, and list of offerings below, *id. ib.* 187-8; frieze-text, GRIFFITH and NEWBERRY, *op. cit.* ii, p. 40.

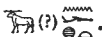
9. KHNEM (?) - NAKHT .

Plan and elevation, *id. ib.* pl. xx.

Name above entrance, *id. ib.* p. 42.

10. 'AḤANAKHT , Nomarch of the Hare-nome, and DḤUTINAKHT

Plan and elevation, id. ib. pl. xx.

Entrance.

Lintel and jambs; texts, id. ib. pp. 43-4.

Hall.

Left wall. Offering-text, id. ib. p. 44 [right].

Rear wall. Seven unguent vases; text of Dḥutinakht above, id. ib. p. 46.

Frieze-texts, id. ib. pp. 44, 45.

Various.

Remains of inscribed lintel from tomb of 'Ankh . . . , Old Kingdom (?), south of Tomb 2 (cf. supra p. 179), WILKINSON MSS.* xii. 23 [upper].

OLD KINGDOM TOMBS. Below Great Rock-tombs.**TOMB D.C.**



Façade. Graffito of I'-ib , Mayor, Leader of the Two Thrones, temp. Neferfré', ANTHES, *Die Felseninschriften von Hatnub*, pl. 2 [bottom], cf. pp. 18, 104; see GRIFFITH and NEWBERRY, *El Bersheh*, ii, p. 57.

MIDDLE KINGDOM TOMBS**Tombs West of Great Rock-tombs.**

See DARESSY, *Fouilles de Deir el Bircheh* in *Ann. Serv.* i. 17-43; KAMAL, *Fouilles à Deir-el-Bersheh* in *Ann. Serv.* ii. 14-43 with plan; id. *Rapport sur les fouilles exécutées à Deir-el-Barshé* in *Ann. Serv.* ii. 206-22.

SITIPI  and 'ANKH . (17 of KAMAL; C of DARESSY.)

North Room.

Coffin of Dḥutinakht , usurped by woman 'Ankhu , in Cairo Mus. 28099, LACAU, *Sarcophages antérieurs au Nouvel Empire* (Cat. Caire), i, pl. x; ii, pp. 74-6; see DARESSY, op. cit. in *Ann. Serv.* i. 25.

South Room.

Coffin of Sitipi, in Brit. Mus. 34259, see id. ib. 24; *Guide to the First and Second Egyptian Rooms* (1904), p. 57; *Guide to the First, Second and Third Egyptian Rooms* (1924), p. 46; perhaps coffin (with that of Dḥutinakht ) mentioned by NEWBERRY, *Egyptian Historical Notes* in *P.S.B.A.* xxxvi. 36 [8].

SEPI I . (15 of KAMAL; D of DARESSY.)

See DARESSY, op. cit. 26-8.

SEPI II and SEPI III , Commander of troops. (14 of KAMAL; E of DARESSY.)

Outer coffin of Sepi III, in Cairo Mus. 28083, LACAU, op. cit. i, pls. xi, xxv, pp. 170-99; texts, id. *Textes religieux* in *Rec. de Trav.* xxvi. 64-7 [C], 67-72 [A], 73-80 [B], 224-7, 229, xxvii. 53-4 [D], xxix. 150-9 [A], xxx. 69-71 [A], 71-3, 185-93, xxxi. 11 [bottom].

Inner coffin of Sepi III, in Cairo Mus. 28084, LACAU, *Sarcophages* [&c.] (Cat. Caire), i, pl. xx, cf. pp. 199-200.

Model boats, &c., in Cairo Mus., DARESSY, op. cit. in *Ann. Serv.* i. pp. 29-40, with figs.; three boats, Nos. 4947-9 [= DARESSY, figs. on pp. 35-7], REISNER, *Models of Ships and Boats* (Cat. Caire), pls. xxi-xxii, pp. 99-102; No. 4949 [= DARESSY, p. 37], JÉQUIER, *Essai sur la nomenclature des parties de bateaux* in *Bull. Inst. Fr. Arch. Or.* ix, pl. ii, cf. p. 45.

Inner coffin of Sepi $\overline{\square} \text{Ⓞ} \text{Ⓜ}$, Commander of troops, probably from this tomb, in Brit. Mus. 55315, see *Guide to the First, Second and Third Egyptian Rooms* (1924), pp. 41-2.

NEFERI $\overline{\text{Ⓜ}} \text{Ⓜ} \text{Ⓜ}$, Chief Steward. (13 of KAMAL; F of DARESSY.)

Outer coffin, in Cairo Mus. 28088, LACAU, op. cit. i, pl. xxvii; ii, pp. 10-19; BLACKMAN in ROSS, *The Art of Egypt through the Ages*, p. 144 [2]; text from interior mentioning King Khety II, LACAU, *Le roi* $\text{Ⓞ} \text{Ⓜ} \text{Ⓜ}$ $\text{Ⓞ} \text{Ⓜ} \text{Ⓜ}$ in *Rec. de Trav.* xxiv. 90-1; texts from Book of the Dead, see id. *Textes religieux* in *Rec. de Trav.* xxxiii. 27-37 [F], xxxvi. 209-18 [F], xxxvii. 137-46 [F]; see GAUTHIER, *Le Livre des Rois*, i. 205 [2, i] with note 1.

Inner coffin, in Cairo Mus. 28087, LACAU, *Sarcophages* [&c.] (Cat. Caire), i, pl. xii; ii, pp. 1-9; Book of the Dead from interior of lid, id. op. cit. in *Rec. de Trav.* xxvi. 67-72 [B], 73-80 [A]; see id. ib. xxxiii. 27-37 [E], xxxvi. 209-18 [E], xxxvii. 137-46 [E].

NEHERI $\overline{\text{Ⓜ}} \text{Ⓜ} \text{Ⓜ}$ and DḤUTIḤOTP $\overline{\text{Ⓜ}} \text{Ⓜ} \text{Ⓜ}$. (11 of KAMAL.)

See KAMAL, op. cit. in *Ann. Serv.* ii. 38-43.

Coffin of Neheri, in Cairo Mus. 28095; text, LACAU, *Sarcophages* [&c.] (Cat. Caire), ii, p. 71; KAMAL, op. cit. 40.

Coffin of DḤutiḥotp, in Cairo Mus. 28097; text, LACAU, op. cit. ii, pp. 72-3; KAMAL, op. cit. 38.

AMENEMḤĒT $\overline{\text{Ⓜ}} \text{Ⓜ} \text{Ⓜ}$, Mayor. (21 of KAMAL.)

See id. ib. 17-33.

Outer coffin, in Cairo Mus. 28092; texts, LACAU, op. cit. ii, pp. 51-63; KAMAL, op. cit. 21-4; part of texts of interior, LACAU, *Textes religieux* in *Rec. de Trav.* xxvi. 229-32, xxvii. 221-33 [B-E], xxix. 144-50 [A-E], xxx. 68-9 [B], xxxii. 78-87 [A, B], xxxiii. 27-37 [A, B], xxxiv. 175-82 [A, B], xxxvi. 209-18 [A, B], xxxvii. 137-46 [A, B].

Inner coffin, in Cairo Mus. 28091, LACAU, *Sarcophages* [&c.], i, pls. xiii, xxviii; ii, pp. 37-50; part of texts, KAMAL, op. cit. 24-8; part of texts of interior, LACAU, op. cit. in *Rec. de Trav.* xxx. 68-9 [A], 69-71 [C].

Canopic box; texts, KAMAL, op. cit. 28-30.

SIT-ḤEZ-ḤOTP $\overline{\text{Ⓜ}} \text{Ⓜ} \text{Ⓜ}$. Near last.

See id. ib. 33-7.

Fragment of coffin of Sit-ḥez-ḥotp; text, id. ib. 34.

Offering-table of Kay $\text{Ⓜ} \text{Ⓜ} \text{Ⓜ}$, son of Ḥuḥotp $\overline{\text{Ⓜ}} \text{Ⓜ} \text{Ⓜ}$, found in her pit; name, id. ib. 35.

Coffin of Shemsi $\overline{\text{Ⓜ}} \text{Ⓜ} \text{Ⓜ}$, Friend, in Cairo Mus. 28098; text, LACAU, *Sarcophages* [&c.], ii, pp. 73-4; KAMAL, op. cit. in *Ann. Serv.* ii. 33.

Coffin of woman Dḥutinakht $\overline{\text{Ⓜ}} \text{Ⓜ} \text{Ⓜ}$, usurped from Kay $\text{Ⓜ} \text{Ⓜ} \text{Ⓜ}$, in Cairo Mus. 28094, LACAU, op. cit. i, pl. xxix; ii, pp. 65-70; text, KAMAL, op. cit. 35-6.

SIT-ḤEZ-ḤOTP $\overline{\text{Ⓜ}} \text{Ⓜ} \text{Ⓜ}$, Dyn. XII. On mountain north-east of principal group. (20 of KAMAL; b of DARESSY.)

Outer coffin, in Cairo Mus. 28086; texts, LACAU, *Sarcophages* [&c.], i, pp. 222-37; parts, id. op. cit. in *Rec. de Trav.* xxvi. 227-8 [C], xxvii. 56 [C], 221-33 [A], xxx. 195-6 [B], xxxi. 19 [B].

Inner coffin, in Cairo Mus. 28085, id. *Sarcophages* [&c.], i, pls. xi, xxvi, cf. lvi, and pp. 201-21; parts, id. op. cit. in *Rec. de Trav.* xxvi. 73-80 [C], 225-6 [B], xxvii. 53-4 [E], xxix. 150-7 [B].

DHUTINAKHT , Mayor. On hill-slope facing Deir el-Bersha.

First coffin, in Cairo Mus. 28125; texts, LACAU, *Sarcophages* [&c.], ii, pp. 142-4; KAMAL, op. cit. in *Ann. Serv.* ii. 215-17.

Second coffin, in Cairo Mus. 28123; texts, LACAU, op. cit. ii, pp. 136-41; KAMAL, op. cit. 217-21; part, LACAU, op. cit. in *Rec. de Trav.* xxx. 69-71 [B].

VARIOUS.

Coffin of Dhutihotp , Scribe of the royal archives, Scribe of the coffin, Dyn. XII, from tomb on north slope of valley facing village, in Cairo Mus.; texts, KAMAL, *Fouilles à Deir el-Barchè* in *Ann. Serv.* iii. 278-80; view of interior, SCHÄFER and ANDRAE, *Die Kunst des alten Orients*, 293 [lower].

Coffin of same man (?), LACAU, op. cit. in *Rec. de Trav.* xxxi. 32-3 [B].

Inner coffin of Sepi , Steward, in Louvre A 23, BOREUX, *Guide-Catalogue Sommaire*, i (1932), pl. ix, cf. pp. 107-8.

Tombs South of the Valley.

(Q and S on plan of GRIFFITH and NEWBERRY, *El Bersheh*, ii, pl. ii.)

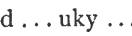
Remains of texts from two tombs, with names of 'Ankhy  and ... uky ... (?) , CLÉDAT, *Notes sur la nécropole de Bersheh* in *Bull. Inst. Fr. Arch. Or.* i. 101-2.

Tombs in the Plain.

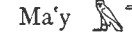
Small objects including names of Henni  and Ma'y ; names, DARESSY, *Fouilles de Deir el Bircheh* in *Ann. Serv.* i, p. 18 with fig. 1.

Planks from coffin of Nefer-zebi , Dyn. XII; texts, KAMAL, op. cit. in *Ann. Serv.* ii. 207.

Alabaster offering-table of Henenit , Priest; text, id. *Fouilles à Deir el-Barchè* in *Ann. Serv.* iii. 277.

ROCK-STELAE

For positions, see GRIFFITH and NEWBERRY, op. cit. ii, pl. ii.

Year 1 of Amenophis III, on north side of valley; text, SAYCE, *A Dated Inscription of Amenophis III* in *P.S.B.A.* ix, plate opposite p. 195; SPIEGELBERG, *Varia* in *Rec. de Trav.* xxvi. 151-2.

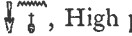
Stela of Sennufer , High priest of Thoth, showing Tuthmosis III before $\frac{1}{4}$ Thoth, year 33, on south side of valley; text, SHARPE, *Eg. Inscr.* 2 Ser. 33 [A], 47; WILKINSON MSS.* xii. 27 [top and middle]; date and cartouches, SETHE, *Urk.* iv. 597 (190) D; NESTOR L'HÔTE MSS.* 20396, 264 [top].

MISCELLANEOUS

Coffins.

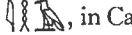
Outer and inner coffins of Iḥa , in Cairo Mus. 28089, 28090, LACAU, *Sarcophages* [&c.] (Cat. Caire), i, pls. xii, xxiii; ii, pp. 20-37; parts of texts, LACAU, *Textes religieux* in *Rec. de Trav.* xxxii. 78-87 [C, D], xxxiii. 27-37 [C, D], xxxiv. 175-82 [C, D], xxxvi. 209-18 [C, D], xxxvii. 137-46 [C, D].

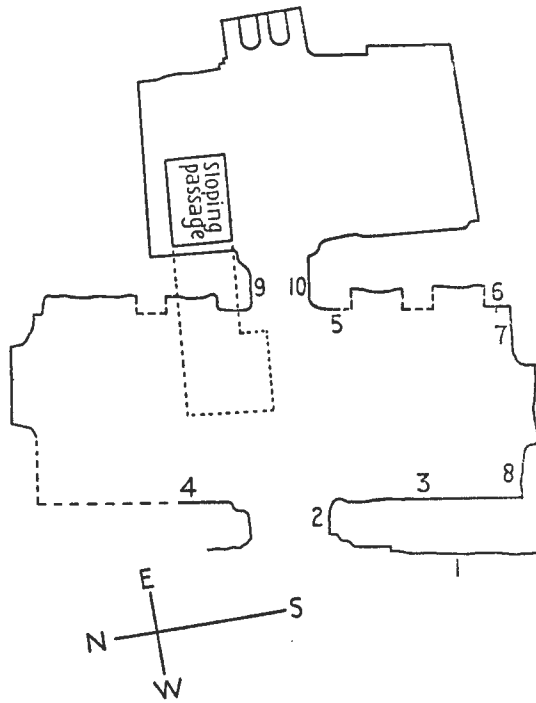

Tomb 1. Serfka. From DAVIES, pl. iii (called Urarna I)

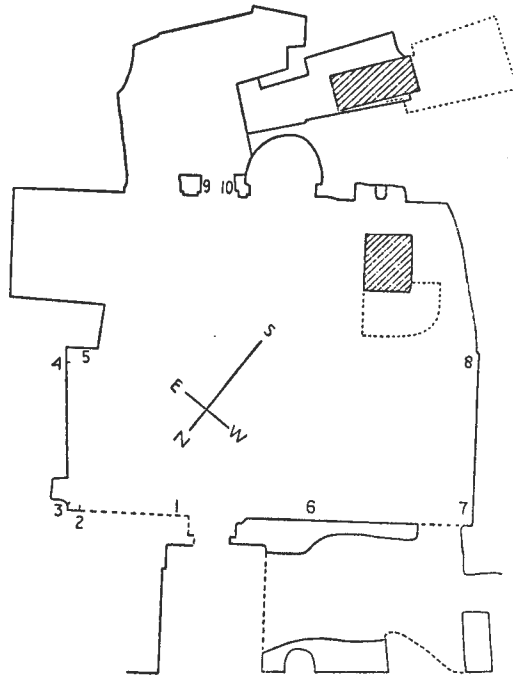



Tomb 2. Werini. From DAVIES, pl. vii.
Both plans are from DAVIES, *The Rock Tombs of Sheikh Said*.



Panel of coffin with name of Nakht , in Cairo Mus. 28096; text, id. *Sarcophages* [&c.] (Cat Caire), ii, p. 72.

Outer and inner coffins from tomb of Gua , Chief physician, Dyn. XI or XII, in Brit. Mus. 30839, 30840, see *Guide to the First, Second and Third Egyptian Rooms* (1924), pp. 42-3; inner coffin, east end of interior, *Guide to the First and Second Egyptian Rooms* (1904), pl. iv opposite p. 58; *Guide to the First, Second and Third Egyptian Rooms* (1924), pl. ii opposite p. 46; *Guide to the Egyptian Collections* (1930), p. 238, fig. 124; the Fields of Iaru on interior, BUDGE, *By Nile and Tigris*, i, plate opposite p. 92. Painted canopic box of Gua, in Brit. Mus. 30838, BLACKMAN in ROSS, *The Art of Egypt through the Ages*, p. 141 [3]; see *Guide to the Third and Fourth Egyptian Rooms* (1904), p. 114 [10]; *Guide to the First, Second and Third Egyptian Rooms* (1924), p. 43 (called in error 38038). Inscribed ivory headrest of Gua, in Brit. Mus. 30727, *Guide to the Egyptian Collections* (1909), fig. on p. 91; (1930), p. 126, fig. 56; *A Guide to the Fourth, Fifth and Sixth Egyptian Rooms* (1922), fig. on p. 26.

Another canopic box, also of Gua, in Brit. Mus. 34272, *Guide to the Third and Fourth Egyptian Rooms* (1904), fig. on p. 113; see *Guide to the First, Second and Third Egyptian Rooms* (1924), p. 150.

Coffin of Sen , Middle Kingdom, in Berlin Mus. 14385, SCHACK-SCHACKENBURG, *Das Buch von den Zwei Wegen des seligen Toten*, passim; see *Aeg. Inschr. Mus. Berlin*, i. 213.

Outer and inner coffins of Sen , Chief of the physicians, in Brit. Mus. 841, 30842; name and title, *Guide to the First and Second Egyptian Rooms* (1904), pp. 48-9, 58; *Guide to the First, Second and Third Egyptian Rooms* (1924), pp. 43-4.

Coffins of Nekht'ankh , Sebkhōtp  (two), and Sepi , Dyn. XI-XII, in Brit. Mus. 35285, 41571-2; names of Nekht'ankh and Sepi, *Guide to the First and Second Egyptian Rooms* (1904), p. 71 [4, 5]; of Nekht'ankh and Sebkhōtp, *Guide to the First, Second and Third Egyptian Rooms* (1924), pp. 45-6.

Offering-tables.

Kay , Chancellor of the King of Lower Egypt, Dyn. XII, in Cairo Mus. 23069; text, KAMAL, *Tables d'Offrandes* (Cat. Caire), pp. 58-9.

Father and son, both Neheri , perhaps from here, in Cairo Mus. 23046; text, id. ib. p. 42.

EL-SHEIKH SA'ÏD

ROCK-TOMBS.¹ Old Kingdom.

Plan of site, DAVIES, *The Rock Tombs of Sheikh Saïd*, pl. i.

- I. SERFKA , *ššm-ti* of the Hare-nome; Prophet of Khufu and Userkaf; Overseer of the New Towns; Overseer of the central nomes of Upper Egypt; &c. (24 of DAVIES.)

Complete, id. ib. pls iv-vi, xvii [middle left] (called in error Urarna I), pp. 10-14. Plan and sections, id. ib. pl. iii. View, NEWBERRY in *Archaeological Report* (1892-3), fig. opposite p. 10.

Façade.

(1) Architrave (destroyed). Remains of offering-text, DAVIES, op. cit. p. 11 [bottom]; L. D. *Text*, ii, p. 121 [top].

¹ The marginal tomb-numbers are those of L. D. *Text*.

Entrance.

(2) Thickness. Deceased with children (almost destroyed); remains of text, DAVIES, *op. cit.* p. 11 [top right].

Outer Hall.

(3) Upper part, deceased and wife receive offerings from son Werirni followed by offering-bringers, lower part, two registers craftsmen, carpenters, musicians, and dancers, *id. ib.* pl. iv; deceased and wife with Werirni, and dwarf and monkey under chair, WILKINSON MSS.* xii. 145 [middle and bottom left]; craftsmen and carpenters, NESTOR L'HÔTE MSS.* 20409, 'Tombeaux de Berschek I', O (squeeze); Werirni, L. D. ii. 112 c; titles and sketch of Werirni with offering-bringers, NESTOR L'HÔTE MSS.* 20396, 261 [middle].

(4) Upper part, remains of scene of receiving taxes, lower part, two registers catching fish in net, and boats, DAVIES, *op. cit.* pl. v [left]; rowing-boat and fish-net, NESTOR L'HÔTE MSS.* 20409, 'Tombeaux de Berschek I', M (squeeze).

(5) Deceased with servant, and dwarf leading dog below, and text at top of wall, DAVIES, *op. cit.* pls. vi [1], xvii [middle left].

(6) and (8) Remains of text from scenes, *id. ib.* p. 12.

(7) Legs of deceased (?) with dog below, WILKINSON MSS.* xii. 145 [top left]; see DAVIES, *op. cit.* p. 12.

Entrance to Inner Hall.

(9) and (10) Thicknesses. On each side deceased with son Werirni and Kaḥap , Royal priest, *id. ib.* pl. vi [2, 3]; L. D. ii. 112 a, b, and *Text*, ii, p. 120 [bottom]; PRISSE, *Mon.* xv [1, 2]; *id.* MSS.* 20433, 32, 33; incomplete, WILKINSON MSS.* xii. 144 [lower left], 146; texts of both scenes, NESTOR L'HÔTE MSS.* 20396, 261 [top], 272 verso [lower], 273, 20409, 'Tombeaux de Berschek I', K (squeeze); cartouches above deceased at (9), *id.* *Lettres écrites d'Égypte*, 51; PRISSE, *Archéologie Égyptienne in Rev. Arch.* (1844), 728.

2. WERIRNI , Overseer of the New Towns; Prophet of Ne-userre'; &c.; son of Serfka. (25 of DAVIES.)

Complete, DAVIES, *op. cit.* pls. viii-xvi, frontispiece, pl. xvii [middle right], cf. pp. 14-24. Plan and sections, *id. ib.* pl. vii.

Outer Hall.

(1)-(2) Remains of scene of deceased and wife receiving produce, *id. ib.* pl. xiii [c, d].

(3)-(4) Deceased (destroyed by later recess) fowling in marshes, and four registers netting fowl, gathering papyrus, making reed-canoes, fishing with net, *id. ib.* pls. xi, xii; canoe and hippopotami from fowling scene, and fish in net, WILKINSON MSS.* ii. 29 verso [right and left lower]; part, NESTOR L'HÔTE MSS.* 20409, 'Tombeau au sud de Berschek', C (squeeze); second canoe from third register, and hippopotamus beneath deceased, HAMILTON, *Aegyptiaca*, xxii [6]; two men preparing fish, from fourth register, PRISSE, *Mon.* xliii [2].



(5) Titles above destroyed niche, DAVIES, *op. cit.* pl. xiii [A].

(6) Four registers agricultural scenes before deceased, *id. ib.* frontispiece, pls. viii, xv-xvi; part, NESTOR L'HÔTE MSS.* 20409, 'Tombeau au sud de Berschek', B, E, F, H, I, J, K (squeezes); top register, one plough, and rams treading in grain, PRISSE, *Mon.* xliii [3]; group of second plough, and rams, DEVÉRIA squeezes*, 6169, ii. 54-5; names of sons from destroyed portion in front of deceased, L. D. *Text*, ii, p. 121 [middle]; men with loaded ass from third register, PRISSE, *Mon.* [xliii 1]; DEVÉRIA squeezes*, 6169, ii. 56.

(7)-(8) Three registers, offerings and offering-bringers, butchers, musicians and dancers, before deceased seated at offering-table, DAVIES, op. cit. pls. ix, x; deceased, offerings, and two priests, NESTOR L'HÔTE MSS.* 20396, 259, 273 verso; third register, musicians and dancers, KEES, *Studien zur aegyptischen Provinzialkunst*, pls. vii, viii.

Entrance to Inner Hall.

(9) and (10) Thicknesses. Deceased and sons; names, DAVIES, op. cit. pl. xvii [middle right], and p. 16.

3. MERU , called BEBI , Ruler of the House of Pepy, and of the House of Teti (?); Judge and 'd-mr of the Southern Throne; &c. (20 of DAVIES.)

Complete, id. ib. pls. v [top right], xix-xxi [upper], xvii [upper], and pp. 24-7. Plan and section, id. ib. pl. xviii; plan, NESTOR L'HÔTE MSS.* 20396, 271 [top].

Entrance to Outer Hall.

(1) Thickness; deceased with son (?), DAVIES, op. cit. pl. v [top right].

Outer Hall.

(2)-(3) Deceased (?) leaning on staff, deceased and wife with family, and statue in niche, id. ib. pl. xvii [top right]; sketch, NESTOR L'HÔTE MSS.* 20396, 271 [middle upper]; names and titles of wife and son, L. D. *Text*, ii, p. 122 [upper middle].

(4) Man offering bird, DAVIES, op. cit. pl. xxi [upper left].

(5)-(6) Statues in niches with architrave-text above, id. ib. pl. xxi [upper]; one statue, DEVÉRIA squeezes*, 6166. i. 4 [right]; north part of architrave-text, L. D. *Text*, ii, p. 122 [near top]; NESTOR L'HÔTE MSS.* 20396, 271 [middle lower].

(7)-(8) Deceased seated before offerings and offering-list, two registers men bringing food and animals below, DAVIES, op. cit. pl. xx; lower part of offering-list, and men with food and animals, WILKINSON MSS.* ii. 31 A, 31 A verso [lower].

(9)-(10) Five registers vases and two offering-bringers, false door, and deceased receiving four registers bringing animals, DAVIES, op. cit. pl. xix; fourth and fifth registers of vases, WILKINSON MSS.* ii. 31 A verso [upper]; false door, and figure of deceased, PRISSE, *Mon.* xv [3]; NESTOR L'HÔTE MSS.* 20396, 258, 258 verso; false door, L. D. ii. 112 d; PRISSE MSS.* 20433, 40; DEVÉRIA squeezes*, 6166. i. f. 4 [left]; part, PRISSE, *Archéologie Égyptienne in Rev. Arch.* (1844), 729; horizontal text above tablet of false door, NESTOR L'HÔTE MSS.* 20396, 272 verso [upper]; titles above deceased, DEVÉRIA squeezes*, 6166. i. f. 4 [right]; names of deceased, L. D. *Text*, ii, p. 121 [bottom].

Entrance to Inner Hall.

(11) Jamb. Six lines text of D̥hutinakht , Dyn. XII, at bottom (now nearly destroyed), L. D. ii. 112 e, cf. *Text*, ii, p. 122 [top]; see DAVIES, op. cit. pl. xxi [upper middle], and p. 38; GRIFFITH and NEWBERRY, *El Bersheh*, ii, p. 10.

(12) Thickness. Deceased (destroyed) with son Behesy (?); deceased with titles, WILKINSON MSS.* xii. 147 [middle]; son, DAVIES, op. cit. pl. xvii [top left].

4. WIU , called YIU , Overseer of Upper Egypt; Great Chief of the Hare-nome; &c. Restored in Dyn. XII. (19 of DAVIES.)

Id. ib. pls. xxi [lower], xxiii, xxiv, pp. 27-9. Plan, id. ib. pl. xxii [lower left].

Entrance.

(1) Thickness; restoration-text (cut out) of D̥hutinakht  (see supra), L. D. ii. 113 b; NESTOR L'HÔTE MSS.* 20409, 'Tombeaux de Bersheh I', N (squeeze); see DAVIES, op. cit. p. 28.

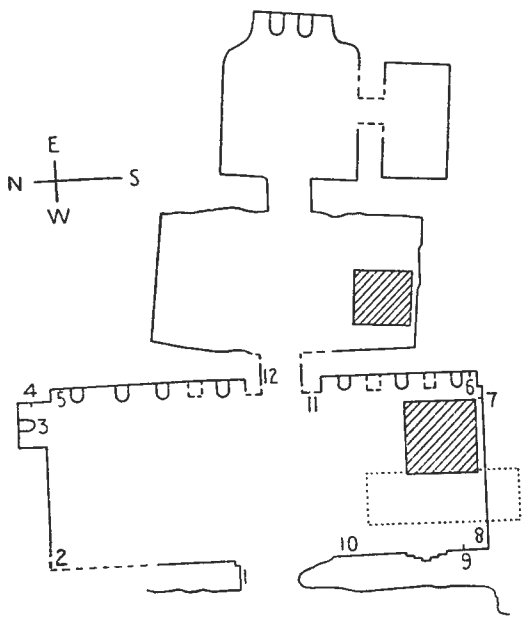

Tomb 3. Meru, called Bebi. From DAVIES, pl. xviii.

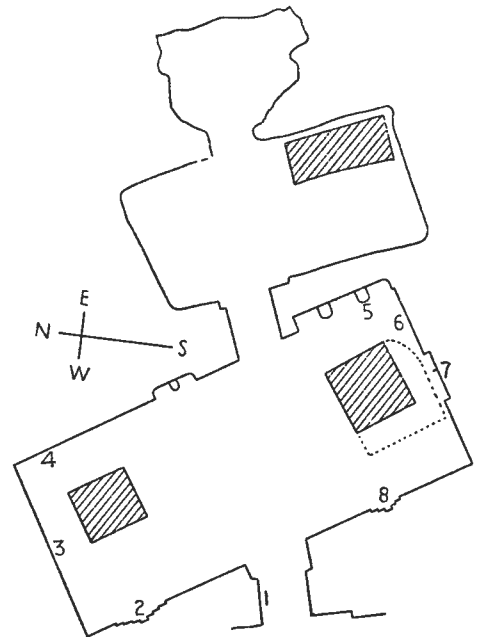

Tomb 4. Wiu. From DAVIES, pl. xxii [lower left].

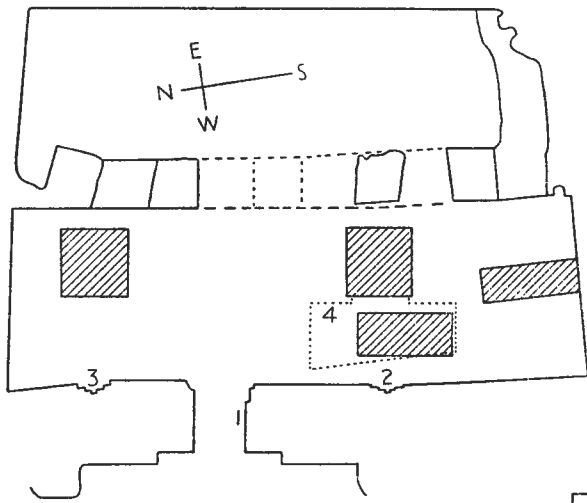

Tomb 5. Meru and Henent. From DAVIES, pl. xxii [right].

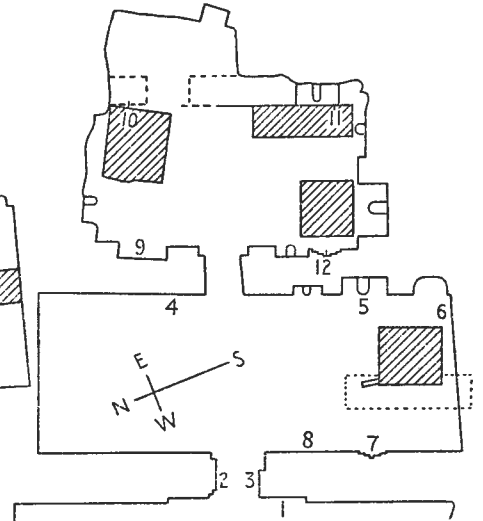

Tomb 6. Teti'-ankh (Pepy'-ankh of LEPSIUS). From DAVIES, pl. xxvii [lower].

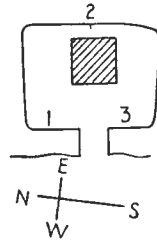

Hēpi. From DAVIES, pl. xxvii [upper].

All these plans are from DAVIES, *The Rock Tombs of Sheikh Saïd*.

Hall.

(2) False door (damaged), id. ib. pl. xxiii; L. *D.* ii. 113 a (incomplete), cf. *Text*, i, p. 122 [lower middle]; NESTOR L'HÔTE MSS. 20396, 260, 262, 270 verso [bottom middle], 20409, I, J, L, 'Tombeaux de Berscheh I' (squeezes).

(3) Offering-bringers before deceased; two bottom rows of offering-bringers and two titles, DAVIES, op. cit. pl. xxiv [c], and p. 29 [bottom].



(4)-(5) Destroyed scene, statue, entrance to Inner Hall, and two statues, id. ib. pl. xxi [lower]; titles of deceased on right jamb, L. *D.* *Text*, ii, p. 122 [bottom right]; part of texts on jambs, NESTOR L'HÔTE MSS.* 20396, 270 verso [bottom right]; deceased and son north of door, DAVIES, op. cit. pl. xxiv [D]; text of son, L. *D.* *Text*, ii, p. 122 [bottom left]; architrave-text, DAVIES, op. cit. pl. xxiv [A].

(6) Four registers, butchers, presentation of antelopes, and boats; remains of boat, id. ib. pl. xxiv [B], cf. p. 29.

Recess.

(7) Deceased and wife; remains of text, id. ib. p. 29 [left.]

(8) False door (destroyed); remains of text with name of wife, id. ib. p. 28.

5. MERU , Ruler of the Residence; Chancellor of the King of Lower Egypt; Intimate; and HENENT . (18 of DAVIES.)

Id. ib. pls. xxv, xxvi, pp. 30-1. Plan, section, and elevation, id. ib. pl. xxii [right, and top left].

Entrance.

(1?) Thickness (?) (destroyed); fragment of dedication-text, L. *D.* *Text*, ii, p. 122 a.



Hall.

(2) False door of Henent, DAVIES, op. cit. pl. xxv; part, NESTOR L'HÔTE MSS.* 20396, 257, 270 [lower]; name and title, L. *D.* *Text*, ii, p. 123 [top].

(3) False door; remains of titles of Meru on jamb, DAVIES, op. cit. p. 31.

Sepulchral Chamber.

(4) Offering-list, id. ib. pl. xxvi.

6. TETI-ANKH , called IMHÔTEP , (Pepy-'ankh ) according to LEPSIUS), Ruler of the House of Pepy; Overseer of the New Towns; &c. Restored in Dyn. XII. (15 of DAVIES.)

Id. ib. pls. xxviii-xxx, pp. 31-4; see NESTOR L'HÔTE MSS.* 20396, 269-269 verso. Plan and elevation, DAVIES, op. cit. pl. xxvii [lower].

Façade.

(1) Later dedication-text of Iha , id. ib. pl. xxix [upper, E]; L. *D.* *Text*, ii, p. 123 [right].

Entrance to Outer Hall.

(2) and (3) Thicknesses; remains of titles, DAVIES, op. cit. p. 32.

Outer Hall.

(4) At bottom, restoration-text of Dḥutinakht (see supra p. 189), id. ib. pl. xxx [left]; L. *D.* ii. 113 c.

(5) Niche; remains of text above, DAVIES, op. cit. pl. xxix [c].

(6) Deceased with son; titles above, id. ib. pl. xxix [D]; NESTOR L'HÔTE MSS.* 20396, 257 verso [right], 270 [upper].

(7) False door, DAVIES, op. cit. pl. xxviii, p. 33 [left]; NESTOR L'HÔTE MSS.* 20409, 'Tombeaux de Berschah I', A-H (squeezes); south jambs (destroyed), L. D. ii. 113 d, e, cf. *Text*, ii, p. 123 [middle].

(8) Deceased and wife receiving three registers fowl and animals, DAVIES, op. cit. pl. xxix [lower]; deceased and wife with titles, NESTOR L'HÔTE, *Lettres écrites d'Égypte*, 52; titles above deceased, id. MSS.* 20396, 269 verso; one title, L. D. *Text*, ii, p. 123 [left].

Inner Hall.

(9) Niche; titles of deceased, DAVIES, op. cit. p. 34.

(10)-(11) Text above niches, id. ib. pl. xxix [A].

(12) False door of wife Bekhent , id. ib. pl. xxx [right].

ḤEPI , Overseer of a department in the forest in the Great House. (22 of DAVIES.)

Plan and sections, id. ib. pl. xxvii [upper], cf. pp. 34-5.

Hall.

(1) Deceased standing, id. ib. pl. xxxi [lower left].

(2) Deceased with son (?), id. ib. pl. xxxi [upper].

(3) Deceased before table, id. ib. pl. xxxi [lower right].

CEMETERIES NEAR SHEIKH ZIBEIDA

South of El-Sheikh Sa'îd.

Stela of Peter , Commander of recruits, dedicated to Amen-rē' of Abu-Kemt, in possession of Idris Bey Raghib, KAMAL, *Rapport sur les fouilles faites dans la montagne de Sheikh Saïd* in *Ann. Serv.* x, pl. i, p. 146 [upper].

Stela of Ptomeḥ (?) , Standard-bearer of His Majesty, Dyn. XVIII, dedicated to Amen-rē' and Prince Sipaar (son of Amosis), in Cairo Mus.; texts, id. ib. pp. 146 [lower]-7.

Upper part of stela, Ramesses II before Thoth, and fragment with quarrying inscription, perhaps belonging to it; texts, id. ib. pp. 148-9 [1^o, 2^o].

Inscriptions on small objects, Dyn. XVIII, id. ib. pp. 149-51 with fig. 1.

X. EL-'AMARNA AND HET-NUB

EL-'AMARNA

General plans, L. D. i. 63 [lower], 64; PETRIE, *Tell el Amarna*, pls. xxxiv, xxxv; BORCHARDT, *Voruntersuchung von Tell el-Amarna im Januar 1907* in *Mitteil. d. Deutsch. Or. Gesell.* Sept. 1907, No. 34, p. 17, Abb. 11; FRANKFORT and PENDLEBURY, *The City of Akhenaten*, ii, pl. i; RICKE, *Der Grundriss des Amarna-Wohnhauses*, pl. i; central part, *Descr. de l'Égypte, Ant.* iv, pl. 63 [6]; PRISSE, *L'Art Égyptien*, i, *Architecture*, pl. 38 'Plan des ruines de Tell el-Amarna'; WILKINSON, *M. and C.* ii, pl. vi opposite p. 106 = ed. BIRCH, i, p. 350, pl. vii; BURTON MSS.* 25634, 72; part, HAY*, 29814, 20; south part of town, GRIFFITH, *Excavations at El-'Amarnah, 1923-4* in *J.E.A.* x, pl. xxxvi opposite p. 304; north part of town, FRANKFORT, *Preliminary Report on the Excavations* [&c.] in *J.E.A.* xiii, pl. xlv opposite p. 209. Description, BONOMI MSS.* Diary, Jan. 16, 1825.

City of Akhetaten. Temp. Amenophis IV.

GREAT GATE

See PENDLEBURY, *Preliminary Report* [&c.] in *J.E.A.* xvii. 242-3; xviii. 143-4. Views, id. ib. xvii, pl. lxxviii [1, 2, 4]; xviii, pl. xiii [4]. Reconstruction of elevation, id. ib. pl. xii [upper].

WINDOW-ROOM ABOVE GATE.

Reconstruction, id. ib. pl. xii [lower].

Fragments of wall-painting, id. ib. in *J.E.A.* xvii, pls. lxxii [1, 2], lxxviii [3], cf. p. 242.

PALACE OF NEFERTITI (?). West of wall of Great Gate.

See id. ib. in *J.E.A.* xviii, pp. 144-5, pl. xiii [3, 5].

Fragments of inlaid alabaster vase of Amenophis IV and Nefertiti, id. ib. pl. xiv [4].

NORTH PALACE

See NEWTON, *Excavations at El-Amarnah, 1923-4* in *J.E.A.* x, pp. 294-8; FRANKFORT, op. cit. in *J.E.A.* xiii, p. 218; WHITTEMORE, *The Excavations at El-Amarnah, Season 1924-5* in *J.E.A.* xii, pp. 3-9; DAVIES in FRANKFORT, *The Mural Painting of El-Amarnah*, pp. 58-71. Plan, NEWTON, op. cit. pl. xxviii; WHITTEMORE, op. cit. pl. ii; FRANKFORT, *The Mural Painting of El-Amarnah*, pl. xiv. Views, NEWTON, op. cit. pls. xxix, xxxi; WHITTEMORE, op. cit. pls. iii-v.

GREAT OUTER COURT.

Sculptor's trial-piece, princess eating duck, found outside entrance, NEWTON, op. cit. pl. xxiii [1], cf. p. 295; NEWBERRY in ROSS, *The Art of Egypt through the Ages*, p. 163.

COURT WITH ALTARS.

Jamb with name of Princess Merytaten from second chamber from north on west side, NEWTON, op. cit. pl. xxiii [3], cf. p. 295.

ENCLOSURE FOR OXEN AND ANTELOPES.

Mangers with reliefs of oxen, ibex, and antelopes, id. ib. pl. xxx, cf. p. 296; one with remains of bull, in Copenhagen, Ny Carlsberg Mus. Æ.I.N. 1641, MOGENSEN, *La Collection égyptienne*, pl. lxxix [A 544, 544 bis], cf. p. 70; one with oxen, in Brit. Mus. 57395, see *Guide to the Egyptian Collections* (1930), p. 358.

SOUTH PASSAGE.

West wall, south end. Fragment of fresco, FRANKFORT, op. cit. pl. xii [G].

LARGE HYPOSTYLE HALL.

East wall. Heraldic border, id. ib. pl. xii [A], cf. p. 15.

THRONE ROOM.

Wall-fragment, jars on stands, DAVIES in id. ib. pl. xii [E], cf. p. 69.

NORTH-EAST COURT AND CUBICLES ROUND IT.

Court.

East end of south wall. Fragment of fresco of lotus-pool (destroyed), id. ib. pl. vii [B], cf. p. 69.

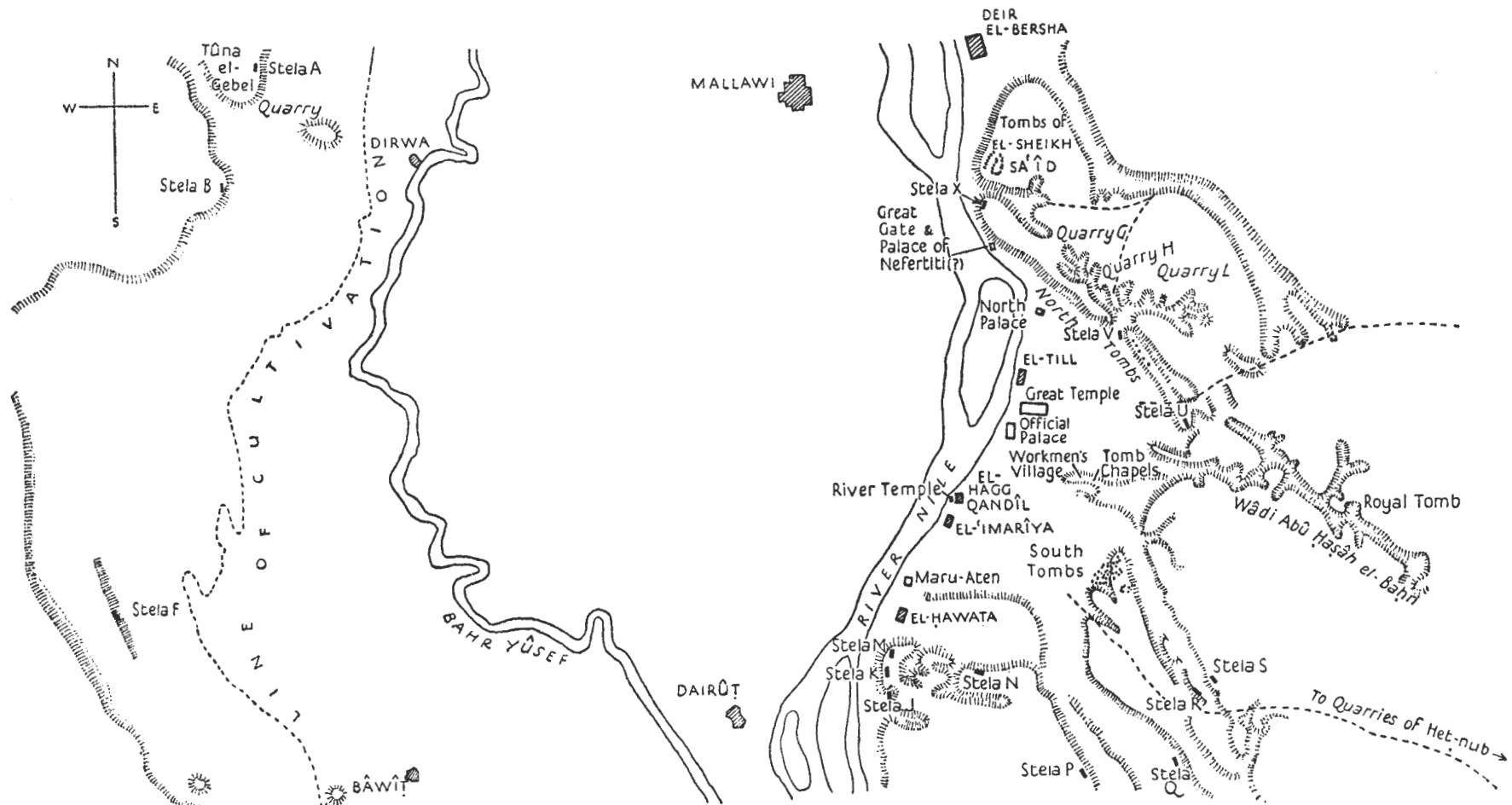

EL-'AMARNA. KEY-PLAN.
 After PETRIE, *Tell el Amarna*, pl. xxxiv.

'Green Room' Cubicle, on north side.

See id. ib. pp. 59-68.

East wall. Fresco of papyrus-pool with doves, id. ib. pls. ii, iii, vii [A, C], viii [B], ix [B]; some of the water-plants, DAVIES, *The Egyptian Expedition 1925-6* in *N. Y. Metro. Bull.* Pt. ii, Dec. 1926, cover and p. 14, fig. 10.

West wall. Fresco with shrike, pigeons, kingfisher, &c., DAVIES in FRANKFORT, op. cit. pls. iv-vi, viii [A]; south part, FRANKFORT, op. cit. in *J.E.A.* xiii, pls. liv, li [3], cf. p. 218; fragment of fresco of lotus-pool from north part, in Copenhagen, Ny Carlsberg Mus. Æ.I.N. 1665, MOGENSEN, op. cit. pl. cxxii [A 793], cf. p. 112; one pigeon [= DAVIES, pl. iv (top left)], LANSING, *The Exhibition of Egyptian Wall Paintings* in *N. Y. Metro. Bull.* Jan. 1930, fig. on p. 7 (from painting by DAVIES).

Other Cubicles.

Fragments of frescoes, including attendants feeding geese, DAVIES in FRANKFORT, *The Mural Painting* [&c.], pls. x, xi, xii [B, F], cf. p. 70; fragment with geese, and vine-pattern from ceiling, NEWTON, op. cit. in *J.E.A.* x, pl. xxxii, cf. pp. 297-8.

VARIOUS.

Fragments of fresco from south-west corner of Colonnade, from pillar in south-east Hall, and from steps south of Transverse Hypostyle, DAVIES in FRANKFORT, op. cit. pls. xii [C, D, H], cf. pp. 69, 71.

Unplaced fragments, FRANKFORT, op. cit. pl. ix [A, C], cf. p. 25.

GREAT TEMPLE

See PETRIE, *Tell el Amarna*, pp. 18-20; FRANKFORT, op. cit. in *J.E.A.* xiii, pp. 209-11. Plan, *L. D. Text*, ii, p. 124; PETRIE, op. cit. pl. xxxvii; since recent excavations, PENDLEBURY, *Preliminary Report on Excavations at Tell el-Amarnah, 1932-3* in *J.E.A.* xix, pl. xiii. Views, id. ib. pl. xiv, cf. pp. 113-17. For reconstruction of temple, see DAVIES, *The Rock Tombs of El Amarna*, ii, pp. 20-8, iii, pp. 19-25.

Fragment of limestone stela, Amenophis IV worshipping, (from Amherst Collection), PETRIE, op. cit. pl. xii [1], cf. pp. 8, 11; *Sale Catalogue of the Amherst Collection* (1921), pl. xiv [845].

Two fragments from scene of Nefertiti and Princesses, in New York, Metropolitan Mus., PETRIE, op. cit. pl. viii [1, 2], cf. p. 18; RANSOM WILLIAMS, *Wall Decorations of the Main Temple of the Sun at El-Amarnah* in *Metropolitan Museum Studies*, ii, pp. 138, 139, figs. 1, 2.

Fragment with chariots, in New York, Metropolitan Mus., FRANKFORT, op. cit. in *J.E.A.* xiii, pl. xlv [1] opposite p. 210; RANSOM WILLIAMS, op. cit. p. 149, fig. 8; LANSING, *Accessions to the Egyptian Collection* in *N. Y. Metro. Bull.* June 1928, p. 161, fig. 2.

Fragment with altars and sacrificial animals, in New York, Metropolitan Mus., RANSOM WILLIAMS, op. cit. p. 147, fig. 7.

Fragment with part of cartouche, PETRIE, op. cit. pl. xi [5], cf. p. 11.

Fragment of relief, in Brussels, Musées Royaux du Cinquanteenaire, *Chronique d'Égypte*, Dec. 1927, p. 32.

Deposit of bronze vases with cartouches of Amenophis IV, Nefertiti, and the Aten, one dedicated by Ra'mosi , Standard-bearer of the legion of Sehetep-Aten, found beneath floor; two vases, FRANKFORT, op. cit. in *J.E.A.* xiii, pl. xlvi and p. 210.

Trial-piece with two royal heads, two trial-pieces with head of Nefertiti, sandstone head for inlay and part of limestone head, both of Amenophis IV, PENDLEBURY, op. cit. pls. xv [1-3], xvi [1], xix [3], cf. p. 116.

(For alabaster head of Amenophis IV, see Smaller Temple, *infra* p. 197.)

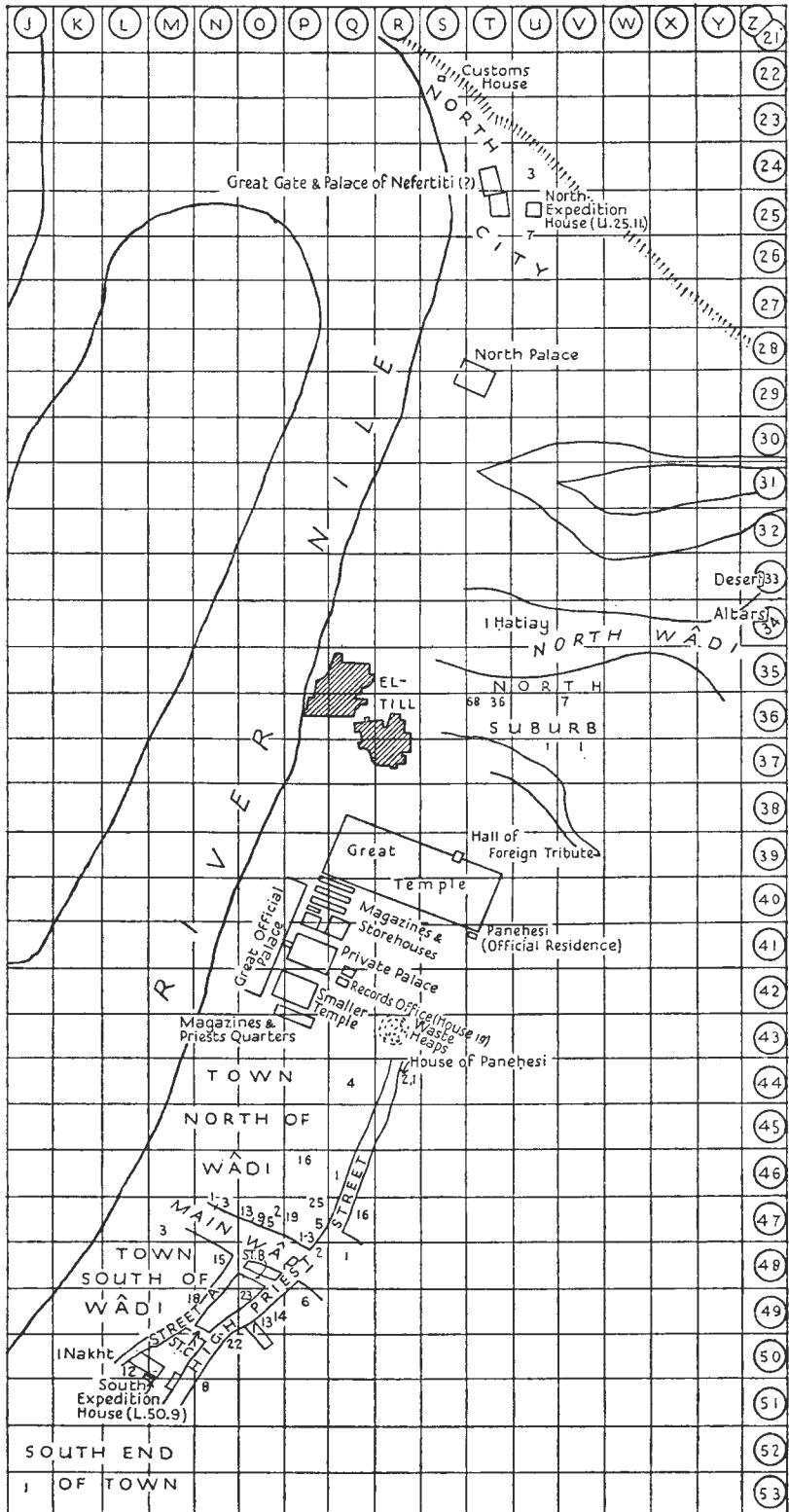

EL-AMARNA. TOWN.

Adapted from BORCHARDT in *Mitteil. d. Deutsch. Or. Gesell.* Dec. 1914, No. 55, pl. 1, and plans made by the Egypt Exploration Society, some published in *J.E.A.*

FOUND WEST OF TEMPLE.

Death-mask of Amenophis IV, in Cairo Mus. 753, PETRIE, op. cit. pl. i [10] and frontispiece, cf. p. 40; BORCHARDT, *Ausgrabungen in Tell el-Amarna 1912/13* in *Mitteil. d. Deutsch. Or. Gesell.* Oct. 1913, No. 52, pl. 3 [right]; id. *Statuen und Statuetten* (Cat. Caire), iii, pl. 140, cf. p. 75; BREASTED, *A History of Egypt* (1905), fig. 143 opposite p. 376; PENDLEBURY, op. cit. pl. xix [4]; STEINDORFF, *Die Blütezeit des Pharaonenreichs* (1900), p. 151, Abb. 126.

FOUND SOUTH OF TEMPLE.

Fragment with cartouches of Amenophis IV and the Aten on front and sides, WILKINSON MSS.* v. 28 [lower].

FOUND IN 'FAVISSA' OUTSIDE SOUTH ENCLOSURE OF TEMPLE.

Fragments of statues of Amenophis IV and Nefertiti, in New York, Metropolitan Mus., RANSOM WILLIAMS, *Two Egyptian Torsoes from the Main Temple of the Sun at El Amarna* in *Metropolitan Museum Studies*, iii, pp. 83, 85, 89, figs. 1-9; fragment of Queen, PETRIE, op. cit. pl. i [13], cf. p. 18.

SMALLER TEMPLE 

See PENDLEBURY, *Preliminary Report* [&c.] in *J.E.A.* xviii. 145-7; HARTLEBEN, *Champollion, Sein Leben und Sein Werk*, ii, p. 231. Plan, CHAMPOLLION, *Not. Descr.* ii. 466; *L. D. Text*, ii, p. 124; PENDLEBURY, op. cit. pl. xvi [middle]. Plan and sections of great brick gateway to First Court, *Descr. de l'Égypte, Ant.* iv, pl. 63 [7-10], cf. *Texte*, iv. 309-11. Views, PENDLEBURY, op. cit. pl. xvii.

Fragments of sculpture, including head of princess from double-statue, id. ib. pls. xiv [2, 3], xviii [2, 4], xix [1].

Torso of colossal limestone statue of Amenophis IV with stela on back and unerased Aten-cartouches; texts, BURTON MSS.* 25634, 94 [middle upper], 25636, 23 [lower]; cartouches, id. *Excerpta Hiero.* pl. vi [2]; HAY*, 29847, 55 [bottom]; WILKINSON MSS.* v. 28 [upper]-29 [upper]; part, CHAMPOLLION, *Not. Descr.* ii. 322 [2]; see WILKINSON, *Modern Egypt and Thebes*, ii. 77.

Fragment of alabaster head of Amenophis IV, either from here or from Great Temple, in Brit. Mus. 13366, PERRING, *On some Fragments from the Ruins of a Temple at El Tell* in *Trans. Roy. Soc. Lit.* (1843), 2nd Ser. i, pp. 140-8; see *Guide to the Fourth, Fifth and Sixth Egyptian Rooms* (1922), p. 128 [65]; PETRIE, *Tell el Amarna*, p. 7 [11]; RANSOM WILLIAMS, op. cit. p. 98, note 103.

MAGAZINES P. 43. 1, AND PRIESTS' QUARTERS P. 43. 2.

See PENDLEBURY, op. cit. in *J.E.A.* xviii, p. 147, pl. xiii [2]. Plan, id. ib. pl. xvi [right].

Fragments of inscribed fayence statuette of foreigner, found in P. 43. 1, id. ib. pl. xviii [1].

GREAT OFFICIAL PALACE

See PETRIE, op. cit. pp. 7-15. Plan, id. ib. pl. xxxvi; HAY*, 29814, 20.

STORE-ROOMS NORTH OF GREAT PILLARED HALL.

Blue paste fragments of vase with names of Amenophis IV and Nefertiti, engraved glass, Aegean pottery, &c., PETRIE, op. cit. pl. xiii [27, 36], cf. p. 7 [13].

CENTRAL PART.

Fragments of vine-columns, id. ib. pl. viii [3-14], cf. pp. 8, 10.

DOORWAY (?).

Fragments of alabaster stelae on either side of entrance, id. ib. pl. xii [2-4], cf. pp. 8, 11.

SMALL BUILDING (P of PETRIE).

Fragments of stone columns, id. ib. pl. vii [left upper], ct. pp. 8, 10.

LIVING QUARTERS.

South-east columned room, First Hall, and Transverse Hall (P 1, 2, 3 of PETRIE).

Painted pavement (recently destroyed) in south-east room, PETRIE, op. cit. pls. ii-iv, cf. pp. 13-14; STEINDORFF, op. cit. (1900), p. 150, Abb. 125; (1926), p. 174, Abb. 162; FARINA, *La Pittura Egiziana*, cxlii; part [= PETRIE, pl. iv], PETRIE, *Seventy Years in Archaeology*, plate opposite p. 138 [lower]; fragment (now destroyed) with young calf and birds (cf. PETRIE, pl. ii), BORCHARDT, *Ausgrabungen in Tell el-Amarna 1911-12 in Mitteil. d. Deutsch. Or. Gesell.* Oct. 1912, No. 50, p. 4, Abb. 1; id. *Das altägyptische Wohnhaus* [&c.] in *Zeitschrift für Bauwesen*, vol. 66 (1916), pp. 551-2, Abb. 58; TIMME, *Tell el-Amarna* [&c.], p. 18, Abb. 15; SCHÄFER, *Die Religion und Kunst von El-Amarna*, pl. 6; SCHÄFER and ANDRAE, *Die Kunst des alten Orients*, 365 [lower].

Fresco in First Hall. East wall, at base, servants preparing for return of master, PETRIE, *Tell el Amarna*, pl. v, cf. p. 14.

Fresco of duck in swamp, in Cairo Mus., BORCHARDT and REISNER, *Works of Art*, 32 [lower].

Open Court.

Reconstruction of stone column of gallery in front of cubicles, PETRIE, op. cit. pl. vii [middle], cf. p. 9. Fragment of column, in Berlin Mus. 12031, BORCHARDT, *Die Aegyptische Pflanzensäule*, p. 50, Abb. 79; cf. *Ausführ. Verzeichnis* (1899), p. 129.

Columns with decoration of figures of royal family, PETRIE, op. cit. pl. x [1-4], cf. p. 10.

Jambs and lintels, in Cairo Mus. and Oxford, Ashmolean Mus., see id. ib. p. 11 [18].

Coping-stone of well with titles of Queen, id. ib. pl. x [5], cf. pp. 8 [14], 9.

FINDS.

Block, gazelles in desert, found near 'bases of columns', and fragments of reliefs, id. ib. pls. ix [bottom left], xi [1, 3, 6-9], cf. p. 11.

Four painted fragments with cartouches of the Aten and Queen Nefertiti, in Brussels, Musées Royaux du Cinquantenaire, E. 1860; texts, SPELEERS, *Rec. des Inscr. Ég.* 39 [145].

Fragments of reliefs, in Berlin Mus. 2069, 12039, 12042, *Aeg. Inscr. Mus. Berlin*, ii. 222, 263, cf. *Ausführ. Verzeichnis* (1899), p. 129.

Statue-base with names of Queen Nefertiti and Princess 'Ankhesenpa-aten, found in village of El-Till but probably from here, GRIFFITH, *Excavations at Tell el-Amarnah, 1923-4* in *J.E.A.* xvii, pl. xxvii [4, 5].

WASTE-HEAPS EAST OF PALACE.

Rings with cartouches of Tuthmosis III, Amenophis III, Amenophis IV, and Smenkhkarē, Aegean pottery, &c., see PETRIE, op. cit. pp. 15-17, pls. xxvi-xxx; PEET, *Excavations at Tell el-Amarna* [&c.] in *J.E.A.* vii. 182-3.

PRIVATE PALACE

See PENDLEBURY, *Preliminary Report* [&c.] in *J.E.A.* xviii, p. 147, cf. pl. xiii [1]. Plan, id. ib. pl. xvi [left]; part, PETRIE, op. cit. pl. xl, cf. xxxv.

PALACE (House 13 of PETRIE; P. 42. 1 of PENDLEBURY).

Fresco of princesses, in Oxford, Ashmolean Mus., PETRIE, op. cit. pl. i [12], cf. pp. 15 [27], 23 [45]; id. *Seventy Years in Archaeology*, plate opposite p. 138 [top]; SCHÄFER and ANDRAE, *Die Kunst des Alten Orients*, pl. xvii; BORCHARDT, *Porträts der Königin Nofret-ete*, p. 29, Abb. 26; restoration of scene from other fragments, and princesses in colour, DAVIES, *Mural Paintings in the City of Akhetaten* in *J.E.A.* vii, pls. i, ii; see GLANVILLE in FRANKFORT, *The Mural Painting of El'Amarnah*, pp. 50-1.

Inscribed brick, I. *D. Text*, ii, p. 125 [middle upper]; PETRIE, *Tell el Amarna*, pl. xlii [bottom, 'house 13'].

GARDEN.

Two sculptor's trial-pieces with caricature of Amenophis IV and head of princess, PENDLEBURY, op. cit. in *J.E.A.* xviii, pl. xiv [1, 6].

STORE-ROOMS, ETC., EAST OF PALACE (17 of PETRIE; P. 42. 2 of PENDLEBURY).

Plan, PETRIE, op. cit. pl. xlii [17], cf. xxxv, p. 23 [47].

Sculptor's trial-piece with head of King (perhaps Smenkhkarē'), and alabaster jar of Queen Hatshepsut found in north court, PENDLEBURY, op. cit. pl. xix [2, 3], cf. p. 148.

RECORDS OFFICE (House 19 of PETRIE).

Plan, PETRIE, op. cit. pl. xlii [19], cf. xxxv, pp. 23-4 [48].

Fayence label of Amenophis III and Teye, found with cuneiform tablets,¹ now in Brit. Mus. 22878, BEZOLD and BUDGE, *The Tell el-Amarna Tablets in the British Museum*, Introduction, p. x [3]; BORCHARDT, *Miscellen* in *Ä.Z.* xxxiii. 72; HALL, *An Egyptian Royal Bookplate* [&c.] in *J.E.A.* xii, pl. xi [1], p. 33; see *Guide to the Fourth, Fifth and Sixth Egyptian Rooms* (1922), p. 144 [55].

Five alabaster plaques with names of Amenophis III, found with cuneiform tablets,¹ now in Berlin Mus. 10586-8, 17955-6; cartouches, *Aeg. Inschr. Mus. Berlin*, ii. 242; cartouches of one plaque, BEZOLD and BUDGE, op. cit. Introduction, p. x [2]; BORCHARDT, op. cit. 73.

Inscribed bricks, PETRIE, op. cit. pl. xlii [bottom, 'chambers No. 19'], cf. pp. 23-4.

TOWN

See PETRIE, op. cit. pp. 20-5; BORCHARDT, op. cit. in *Mitteil. d. Deutsch. Or. Gesell.* Sept. 1907, No. 34, Nov. 1911, No. 46, Oct. 1912, No. 50, Oct. 1913, No. 52, Dec. 1914, No. 55;² id. op. cit. in *Zeitschrift für Bauwesen*, 66 (1916), p. 509 et seq., pl. 50; PEET and WOOLLEY, *The City of Akhenaten*, i, pp. 1-50, 143-6, cf. pls. x-xiii (with list of museums to which objects have been sent on pp. 172-4); WOOLLEY, *Excavations at Tell el-Amarna* in *J.E.A.* viii, pp. 60-5; PEET, op. cit. in *J.E.A.* vii. 169-75; NEWTON, *Excavations at El'Amarnah, 1923-24* in *J.E.A.* x. 289-94; GRIFFITH, *Excavations at El'Amarnah, 1923-24* in *J.E.A.* x. 299-305; WHITTEMORE, *The Excavations at El'Amarnah, Season 1924-5* in *J.E.A.* xii. 10-12; FRANKFORT, op. cit. in *J.E.A.* xiii.

¹ For great find of cuneiform tablets in 1886, see SAYCE in PETRIE, *Tell el Amarna*, pls. xxxi-xxxiii, pp. 34-7, and other publications.

² Translated, BORCHARDT, *Excavations at Tell el-Amarna, Egypt, in 1913-1914* in *Smithsonian Report* (1915), pp. 447-57 with plates.

216-18; id. *Preliminary Report* [&c.] in *J.E.A.* xv, pp. 143-9, cf. pls. xxiii-xxiv, xxvi [1, 2]; PENDLEBURY, *Preliminary Report* [&c.] in *J.E.A.* xvii. 233-42, 243-4, xviii. 145; GLANVILLE in FRANKFORT, *The Mural Painting of El 'Amarneh*, pp. 31-57.

General plan of southern part, GRIFFITH, op. cit. pl. xxxvi; part south of wâdi showing houses, PEET and WOOLLEY, op. cit. pls. i, ii; part, PEET, op. cit. in *J.E.A.* vii, pl. xxv northern part, FRANKFORT, op. cit. in *J.E.A.* xiii, pl. xliv; plans of German excavations, BORCHARDT, op. cit. in *Mitteil. d. Deutsch. Or. Gesell.* No. 46, pl. 2, No. 50, pl. 1, No. 52, pl. 1, No. 55, pl. 1; RICKE, *Der Grundriss des Amarna-Wohnhauses*, pl. 2; of northern suburb, FRANKFORT, op. cit. in *J.E.A.* xv, pl. xxii; FRANKFORT and PENDLEBURY, *The City of Akhenaten*, ii, pls. ii-xi; of west part of northern suburb, PENDLEBURY, op. cit. in *J.E.A.* xvii, pl. lxxviii; of extreme north end, WHITTEMORE, op. cit. pl. vi; plans of houses and other buildings, PETRIE, op. cit. pls. xxxviii, xxxix, xli, cf. xxxv.

Ostraca and jar-sealings, PETRIE, op. cit. pls. xxi-xxv, cf. GRIFFITH in id. ib. pp. 32-4; PEET and WOOLLEY, op. cit. pl. lxiii [N-R], cf. p. 164; FRANKFORT and PENDLEBURY, op. cit. pls. lvii, lviii, cf. pp. 103-8. Two inscribed jars found in 1901; texts, NEWBERRY, *Extracts from my Notebooks* in *P.S.B.A.* xxv. 138.

North City.

HOUSE U. 24. 3.

Bronze cup with name of Iuaa, Royal scribe, PENDLEBURY, op. cit. in *J.E.A.* xviii, pl. xiv [5], cf. p. 145.

HOUSE U. 25. 7. NAME UNKNOWN. 'Official Residence of the High priest in the North City.'

Plan and views, id. op. cit. in *J.E.A.* xvii, pls. lxxvi, lxxvii, cf. pp. 240-1.

North Wâdi.

HOUSE T. 34. I. ḤATIAY , Overseer of works.

Plan and views, id. ib. pls. lxxiv, lxxv [3, 4], cf. pp. 237-9; FRANKFORT and PENDLEBURY, op. cit. pls. xv, xxii [6], xxiii [1-3], cf. pp. 63-6. Fragments of sculpture and relief, including statue-base of Amenophis IV (?), and mortar of Menkheper , id. ib. pls. xxxii [1-3], xliv [4-6], p. 59, cf. 16, 20, 34, 47.

Lintel, in Cairo Mus., PENDLEBURY, op. cit. in *J.E.A.* xvii, pl. lxxv [1, 2]; FRANKFORT and PENDLEBURY, op. cit. pl. xxiii [4], cf. pp. 64-5, 109.

North Suburb.

See id. ib. pp. 1-97.

HOUSE T. 35. 4.

Statuette, in Cairo Mus., FRANKFORT, op. cit. in *J.E.A.* xv, pls. xx, xxi, cf. p. 149; FRANKFORT and PENDLEBURY, op. cit. pl. xxxvii.

HOUSE T. 36. 36, &c. The 'Mycenaean House'.

Plan and views, PENDLEBURY, op. cit. pls. lxix, lxx, cf. pp. 234-5; FRANKFORT and PENDLEBURY, op. cit. pls. xiv, xxii [1-3], cf. pp. 44-6. Clay face from tripod, id. ib. pl. xl [1], cf. p. 45.

HOUSE T. 36. 68.

Small head of princess (?), probably 'Ankhesenpa-aten, PENDLEBURY, op. cit. pl. lxxii [3, 4], cf. p. 236; FRANKFORT and PENDLEBURY, op. cit. pl. xliv [1-3], cf. pp. 61, 62.

HOUSE V. 36. 7. NAME UNKNOWN, Tax-collector.

Plan and view, FRANKFORT, op. cit. in *J.E.A.* xv, pls. xxix, xxvi [3], cf. p. 149; FRANKFORT and PENDLEBURY, op. cit. pls. xiii, xix [4], cf. pp. 30-1.

HOUSE U. 37. I.

Views, id. ib. pls. xviii [4, 5], xix [1, 2], cf. pp. 12-14.

Red quartzite head of princess, FRANKFORT, op. cit. in *J.E.A.* xiii, pls. lii, liii, cf. p. 217; FRANKFORT and PENDLEBURY, op. cit. pl. xxxix, cf. p. 13.

HOUSE V. 37. I.

See GLANVILLE in FRANKFORT, *The Mural Painting of El'Amarnah*, pp. 35-7. Plan, id. ib. p. 36, fig. 20. Reconstruction and views, FRANKFORT and PENDLEBURY, op. cit. pls. xvi, xviii [1, 2], cf. pp. 5-8.

Floral garland with ducks as wall-decoration, GLANVILLE, op. cit. pls. xvii, xviii [A], xix, cf. pp. 49-50.

False window frieze from North Loggia, id. ib. pl. xxi, cf. pp. 51, 52.

Temple Area.

HALL OF FOREIGN TRIBUTE.

See FRANKFORT, op. cit. in *J.E.A.* xiii, pp. 213-16. Plan and views, id. ib. pls. lviii, xlix.

OFFICIAL RESIDENCE OF PANEḤESI , Chief servitor of the Aten in Akhetaten. (Cf. House R. 44. 2, infra.)

See id. ib. pp. 211-13. Plans, with sections of shrine, id. ib. pp. 211, 212, figs. 1, 2.

Central Room.

Façade. Floral frieze decoration, GLANVILLE in FRANKFORT, *The Mural Painting* [&c.], pl. xviii [B], cf. p. 51.

Shrine. Amenophis IV and Nefertiti worshipping the Aten, FRANKFORT, op. cit. in *J.E.A.* xiii, pls. xlv [2, 3], xlvii, cf. p. 212, fig. 2.

Finds.

Stela of Amenophis III and Teye before offerings, in Brit. Mus., GRIFFITH, *Stela in Honour of Amenophis III and Taya* [&c.] in *J.E.A.* xii, pl. i, cf. pp. 1-2.

Town north of Wâdi.

HOUSE Q. 44. 4.

Limestone figure of Amenophis IV as boy, NEWTON, op. cit. in *J.E.A.* x, pl. xxiv, cf. p. 289.

HOUSE R. 44. I. NAME UNKNOWN, Steward of Akhetaten.

See GRIFFITH, op. cit. in *J.E.A.* x. 302.

HOUSE R. 44. 2. PANEḤESI , Chief servitor of the Aten in Akhetaten. (Cf. Official Residence, supra.)

See id. ib. p. 302 and pl. xxxiii.

Floral garland wall-decoration, GLANVILLE in FRANKFORT, *The Mural Painting* [&c.], pl. xviii [c], cf. p. 45.

Shrine in Garden.

Head of Amenophis IV, in Copenhagen, Ny Carlsberg Mus. Æ.I.N. 1640, GRIFFITH, op. cit. in *J.E.A.* x, pl. xxxiv [1]; MOGENSEN, *La Collection égyptienne*, pl. iv [A 8], cf. p. 7; id. *Les œuvres d'art de Tell-el-Amarna* [&c.] in *Bull. Inst. Fr. Arch. Or.* xxx, pl. iv [10], cf. p. 462.

Fragments of statues, and unfinished figure of slave, GRIFFITH, *Excavations at Tell el-'Amarnah, 1923-4* in *J.E.A.* xvii, pls. xxvi [2, 3], xxvii [1-3], cf. pp. 182-3.

HOUSE Q. 46. I. NAME UNKNOWN, Overseer of the cattle of the Aten in Akhetaten.

Plan and views, BORCHARDT, op. cit. in *Mitteil. d. Deutsch. Or. Gesell.* Oct. 1913, No. 52, Abb. 1-3, cf. pp. 10-17.

Painted panel with papyrus, found in bathroom, id. ib. p. 22, Abb. 6; id. *Das alt-ägyptische Wohnhaus* [&c.] in *Zeitschrift für Bauwesen*, vol. 66 (1916), p. 555, Abb. 62.

Painted fragments of floral garlands from walls, id. ib. pl. 50 [3, 4, 6].

HOUSE P. 46. 16.

Fragment of lintel with name of Sheri , PEET and WOOLLEY, *The City of Akhenaten*, i, pl. xxxiii [6], cf. p. 33.

HOUSES O. 46. 16a AND 20.

Quartzite head of princess, plaster head of Nefertiti (?), quartzite head for inlay, steatite group of ape and scribe, plaster head of Amenophis IV, &c., PENDLEBURY, op. cit. in *J.E.A.* xix, pls. xii, xviii [3, 4], xv [4], xvi [2-4], xvii, xviii [1, 2], xix [1, 2], cf. pp. 117-18.

HOUSE N. 47. I.

Headless sandstone statue of princess holding offering-table, in Berlin Mus. 21690, SCHÄFER, *Amarna in Religion und Kunst*, pl. 37.

HOUSE O. 47. 5.

Sculptor's model, head of ape, BORCHARDT, op. cit. in *Mitteil. d. Deutsch. Or. Gesell.* No. 55, p. 27, Abb. 8.

HOUSES O. 47. 9 AND 13.

Model mask, and study for relief of head of Amenophis IV, id. ib. pp. 30-1, Abb. 9, 10; relief, in Berlin Mus. 21683, SCHÄFER, *Kunstwerke aus El-Amarna*, i, pl. 4 (called 5 in text); id. *Amarna in Religion und Kunst*, pl. 17; id. *Altes und Neues zur Kunst und Religion* [&c.] in *Ä.Z.* lv, pl. 3 [3], cf. pp. 15, 16.

HOUSE P. 47. 1-3. DḤUTMOŠI, Master-sculptor.

Plan and view, BORCHARDT, op. cit. in *Mitteil. d. Deutsch. Or. Gesell.* No. 52, Abb. 10, 11, cf. pp. 29-50; id. *Porträts der Königin Nofret-ete*, p. 30, Abb. 27-9; plan, RICKE, *Der Grundriss des Amarna-Wohnhauses*, pl. 25.

Painted fragment of floral garland from wall, BORCHARDT, op. cit. in *Zeitschrift für Bauwesen*, vol. 66 (1916), pl. 50 [7].

Sculptor's models, including heads and statue of Nefertiti and princesses, mask and bust of Amenophis IV, &c., id. op. cit. in *Mitteil. d. Deutsch. Or. Gesell.* No. 52, Abb. 19-25, pls. 3 [left], 4 [right]-6; head of princess [BORCHARDT, Abb. 21], id. *Der*

Porträtkopf der Königin Teje, p. 13, Abb. 11; head of Nefertiti [BORCHARDT, Abb. 19], in Berlin Mus. 21300, id. *Porträts der Königin Nofret-ete*, pls. 2-6, cf. pp. 30-8; SCHÄFER, *Die Neuauftellung der Funde aus El-Amarna in Berliner Museen Berichte*, xlv (1924), p. 1, Abb. 1; id. *Kunstwerke aus El-Amarna*, i, frontispiece (called 1 in text); id. *Amarna in Religion und Kunst*, pl. 20; SCHÄFER and ANDRAE, *Die Kunst des alten Orients*, 336; WEIGALL, *Anc. Eg. Works of Art*, 200, 201; unfinished head of Nefertiti [BORCHARDT, Abb. 20], KEES, *Ägyptische Kunst*, p. 104 [32]; bust of King [BORCHARDT, pl. 4 (right)], in Berlin Mus., BORCHARDT, *Porträts [&c.]*, p. 6, Abb. 2; statue of Queen [BORCHARDT, Abb. 25], in Berlin Mus. 21263, SCHÄFER, *Sonderausstellungen der Funde [&c.] in Amtliche Berichte*, xxxv, p. 137, Abb. 78, reprinted in *Ä.Z.* lii, p. 83, Abb. 18; id. op. cit. in *Berliner Museen Berichte*, xlv (1924), p. 9, Abb. 7; id. *Kunstwerke aus El-Amarna*, i, pl. 7 (called 8 in text); id. *Amarna in Religion und Kunst*, pl. 21; id. op. cit. in *Ä.Z.* lv, pl. 6 [2]; STEINDORFF, *Die Blütezeit des Pharaonenreichs* (1926), p. 179, Abb. 167; id. *Die Kunst der Ägypter*, p. 223; SCHÄFER and ANDRAE, op. cit. 338; WEIGALL, op. cit. 202; brown sandstone head of Nefertiti [BORCHARDT, pl. 6], in Berlin Mus. 21220, SCHÄFER, *Kunstwerke aus El-Amarna*, i, cover; id. *Amarna in Religion und Kunst*, pl. 34; SCHÄFER and ANDRAE, op. cit. 337; WEIGALL, op. cit. 199; NEWBERRY in ROSS, *The Art of Egypt through the Ages*, p. 178 [2]; head of princess [BORCHARDT, Abb. 23], SCHÄFER, op. cit. in *Amtliche Berichte*, xxxv, p. 139, Abb. 80, reprinted in *Ä.Z.* lii, p. 83, Abb. 19.

Grey granite head of Nefertiti, in Berlin Mus. 21358, SCHÄFER, *Kunstwerke aus El-Amarna*, i, pl. 6 (called 7 in text); id. *Amarna in Religion und Kunst*, pl. 35; STEINDORFF, op. cit. (1926), p. 178, Abb. 166.

Brown sandstone face of Nefertiti, in Berlin Mus. 21245, SCHÄFER, *Amarna in Religion und Kunst*, pl. 36; WEIGALL, op. cit. 192 [upper].

Brown sandstone head of princess, in Berlin Mus. 21223, SCHÄFER, *Kunstwerke aus El-Amarna*, i, pl. 9 (called 10 in text); id. *Amarna in Religion und Kunst*, pl. 24; SCHÄFER and ANDRAE, op. cit. 335; WEIGALL, op. cit. 205 [left]; NEWBERRY in ROSS, op. cit. p. 178 [1].

Head of Amenophis III, in Berlin Mus. 21299, BORCHARDT, op. cit. in *Mitteil. d. Deutsch. Or. Gesell.* No. 57, p. 14, Abb. 11; SCHÄFER, *Kunstwerke aus El-Amarna*, i, pl. 10 (called 11 in text); id. *Amarna in Religion und Kunst*, pl. 8; STEINDORFF, op. cit. (1926), p. 181, Abb. 171; NEWBERRY in ROSS, op. cit. p. 177 [2].

Head of Amenophis IV, in Berlin Mus. 21351, SCHÄFER, *Amarna in Religion und Kunst*, pl. 14; WEIGALL, op. cit. 194.

Mask of Amenophis IV, in Berlin Mus. 21348, SCHÄFER, op. cit. in *Amtliche Berichte*, xxxv, p. 136, Abb. 77, reprinted in *Ä.Z.* lii, p. 82, Abb. 16; id. op. cit. in *Berliner Museen Berichte*, xlv (1924), p. 8, Abb. 6; id. *Kunstwerke aus El-Amarna*, i, pl. 2 (called 3 in text); id. *Amarna in Religion und Kunst*, pl. 13; SCHÄFER and ANDRAE, op. cit. pl. xiv opposite p. 332; STEINDORFF, op. cit. p. 178, Abb. 165; KEES, *Kulturgeschichte des alten Orients*, i, *Ägypten*, pl. 47.

Five masks, in Berlin Mus. 21356, 21350, 21261-2, 21239, SCHÄFER, *Kunstwerke aus El-Amarna*, i, pls. 11-15 (called 12-16 in text); id. *Amarna in Religion und Kunst*, pls. 9, 38-40, 43; Nos. 21262, 21239, id. op. cit. in *Amtliche Berichte*, xxxv, pp. 145-6, Abb. 85, 86, reprinted in *Ä.Z.* lii, p. 86, Abb. 24, 25; BORCHARDT, op. cit. in *Mitteil. d. Deutsch. Or. Gesell.* No. 52, Abb. 15, 12; Nos. 21350, 21356, 21261, STEINDORFF, op. cit. pp. 180, 181, Abb. 168-70; Nos. 21356, 21261, id. *Die Kunst der Ägypter*, p. 226; Nos. 21350, 21262, SCHÄFER and ANDRAE, op. cit. 339; Nos. 21350, 21239, WEIGALL, op. cit. 203, 204; No. 21261, NEWBERRY in ROSS, op. cit. p. 177 [1 left].

Two male masks, in Berlin Mus. 21359, 21228, SCHÄFER, *Amarna in Religion und Kunst*, pls. 41, 42; No. 21228, BORCHARDT, op. cit. Abb. 14.

HOUSE P. 47. 5.

Remains of painted frieze and wall-decoration, id. ib. p. 18, Abb. 4, cf. p. 17; id. *Das altägyptische Wohnhaus* [&c.] in *Zeitschrift für Bauwesen*, vol. 66 (1916), pp. 553-4, Abb. 60.

Coffin, Dyn. XX, buried in garden, see id. op. cit. in *Mitteil. d. Deutsch. Or. Gesell.* No. 52, p. 9.

HOUSE P. 47. 19. RA'MOSI , Commander of troops of the Lord of the Two Lands.

See id. op. cit. in *Mitteil. d. Deutsch. Or. Gesell.* Dec. 1914, No. 55, pp. 16-24.

Plan, views, and reconstruction of hall, id. op. cit. in *Zeitschrift für Bauwesen*, vol. 66 (1916), pp. 532, 535, 539, 547-8, Abb. 27, 33, 40, 54, and pl. 50 [1]; plan, RICKE, *Der Grundriss des Amarna-Wohnhauses*, pl. 19; view and reconstruction of hall, BORCHARDT, op. cit. in *Mitteil. d. Deutsch. Or. Gesell.* No. 55, p. 22, Abb. 6 and pl. 2.

Inscribed jamb, id. ib. p. 17, Abb. 5; id. op. cit. in *Zeitschrift für Bauwesen*, p. 546, Abb. 52.

HOUSE P. 47. 25.

Relief model for bronze cast, Amenophis IV and Netertiti, in Berlin Mus. 21684, BORCHARDT, op. cit. in *Mitteil. d. Deutsch. Or. Gesell.* No. 55, pls. 3, 4, cf. p. 28; id. *Porträts der Königin Nofret-ete*, p. 28, Abb. 25; MÖLLER, *Die Metallkunst der alten Ägypter*, pl. 47.

HOUSE Q. 47. 16.

Painted triptych (?) in relief, Amenophis IV and Nefertiti with two princesses, found outside outer wall, now in Cairo Mus., BORCHARDT, op. cit. in *Mitteil. d. Deutsch. Or. Gesell.* No. 52, Abb. 9, cf. pp. 26-8; No. 57, p. 5, Abb. 2; id. *Porträts der Königin Nofret-ete*, pl. 1, Abb. 12, 16, cf. pp. 2-13; id. op. cit. in *Zeitschrift für Bauwesen*, vol. 66 (1916), p. 537, Abb. 39; SCHÄFER, op. cit. in *Amtliche Berichte*, xxxv, p. 143, Abb. 84, reprinted in *Ä.Z.* lii, p. 85, Abb. 23; WEIGALL, op. cit. 197 [left]; PROSKAUER, *Zur Pathologie der Amarnazeit* in *Ä.Z.* lviii, p. 117, Abb. 3; see *Cairo Museum, Principal Monuments* (1932), p. 14 [482].

HOUSE P. 48. 2.

Unfinished group of Amenophis IV kissing princess (or Smenkhkarē'), in Cairo Mus.,¹ BORCHARDT, op. cit. in *Mitteil. d. Deutsch. Or. Gesell.* No. 52, pl. 2; id. *Porträts* [&c.], p. 26, Abb. 18, cf. p. 25; SCHÄFER, op. cit. in *Amtliche Berichte*, xxxv, Jan. 1914, p. 140, Abb. 82, reprinted in *Ä.Z.* lii, p. 84, Abb. 21; id. *Amarna in Religion und Kunst*, pl. 49; id. *Grundlagen der ägyptischen Rundbildnerei* in *Der Alte Orient*, xxiii [4], (1923), Abb. 9, cf. p. 15; id. *Ägyptische und heutige Kunst* [&c.], p. 24, Abb. 25, 26; WEIGALL, op. cit. 196; ENGELBACH, *The so-called Coffin of Akhenaten* in *Ann. Serv.* xxxi, pl. iii [2], cf. p. 105; see *Cairo Museum, Principal Monuments* (1932), p. 13 [471].

HOUSE Q. 48. 1.

Ivory carving, Tuthmosis IV with prisoner before hawk-headed Rē', BORCHARDT, op. cit. in *Mitteil. d. Deutsch. Or. Gesell.* No. 55, pl. 5, cf. pp. 30-4; see SCHÄFER, *Altes und Neues zur Kunst und Religion von Tell el-Amarna* in *Ä.Z.* lv, p. 35, with Abb. 30.

Model head of ape, BORCHARDT, op. cit. p. 26, Abb. 7.

¹ Cast in Berlin Mus. G. 472, from which some of the representations are taken.

Town south of Wâdi.

HOUSE M. 47. 3. MAA-NEKHTUTEF , Overseer of builders.

Entrance.

Doorway, in Berlin Mus. 20376, BORCHARDT, op. cit. in *Mittel. d. Deutsch. Or. Gesell.* Nov. 1911, No. 46, pl. 4 opposite p. 19; id. op. cit. in *Zeitschrift für Bauwesen*, vol. 66 (1916), p. 544, Abb. 50; texts, *Aeg. Inschr. Mus. Berlin*, ii. 127-30.

HOUSE N. 48. 15.

Alabaster statue of Amenophis IV, in Berlin Mus. 21835, BORCHARDT, op. cit. in *Mittel. d. Deutsch. Or. Gesell.* No. 50, p. 26, Abb. 18, cf. pp. 24-5; SCHÄFER, *Kunstwerke aus El-Amarna*, i, pl. 3 (called 4 in text); id. *Amarna in Religion und Kunst*, pl. 18.

HOUSE N. 49. 18. RE'NÜFER , Chief groom of His Majesty; Overseer of the horses of the whole stable.

See PEET, *Excavations at Tell el-Amarna* [&c.] in *J.E.A.* vii, pp. 171-4, pl. xxvi (called O. 49. 18); PEET and WOOLLEY, *The City of Akhenaten*, i, pp. 9-15, pls. vii [1, 2, 5], x [6].

North Loggia.

Jambs of entrance; remains of texts, id. ib. p. 8, fig. 1.

Text round west niche, id. ib. pls. ix [3], cf. viii [5], and p. 10, fig. 2.

Floral garland wall-decoration, id. ib. pl. xv; GLANVILLE in FRANKFORT, *The Mural Painting of El'Amarnah*, pl. xx, cf. pp. 48-9.

Finds.

Fragment of jamb of Thapi (?) , Scribe, found in ante-room, PEET and WOOLLEY, op. cit. pl. x [5], cf. p. 9.

Sculptor's trial-piece with head of young man on one side and sketches on other side, found outside east wall, now in Copenhagen, Ny Carlsberg Mus. Æ.I.N. 1587, id. ib. pl. xii [6, 8], cf. p. 14; MOGENSEN, *La Collection égyptienne*, pl. lxxxii [A 633], cf. pp. 80-1; id. *Les œuvres d'art de Tell-el-Amarna* [&c.] in *Bull. Inst. Fr. Arch. Or.* xxx, pl. iv [12], cf. p. 463; side with head of young man, PEET, *Excavations at Tell el-Amarna* [&c.] in *J.E.A.* vii, pl. xxix [4], cf. p. 175.

HOUSE O. 49. I. PEWAḤ , High Solar Priest of the Aten in the Estate of Re'.

Plan, BORCHARDT, op. cit. in *Mittel. d. Deutsch. Or. Gesell.* No. 46, pl. 3 [lower right], cf. p. 15; including shrine in garden, RICKE, *Der Grundriss des Amarna-Wohnhauses*, pl. 20, p. 49, Abb. 46. Views, BORCHARDT, op. cit. pp. 21, 23, Abb. 4, 5.

Jamb with cartouches of Amenophis IV, in Berlin Mus. 20375, id. ib. p. 18, Abb. 3, cf. p. 19; id. op. cit. in *Zeitschrift für Bauwesen*, vol. 66 (1916), p. 545, Abb. 51; text, *Aeg. Inschr. Mus. Berlin*, ii. 126.

Unfinished sculptor's model, relief of Queen offering wine to King, in Berlin Mus. 20716, BORCHARDT, op. cit. in *Mittel. d. Deutsch. Or. Gesell.* Oct. 1912, No. 50, p. 28, Abb. 19, cf. p. 27; SCHÄFER, op. cit. in *Amtliche Berichte*, xxxv, p. 142, Abb. 83, reprinted in *Ä.Z.* lii, p. 84, Abb. 22; id. *Kunstwerke aus El-Amarna*, i, pl. 5 (called 6 in text); id. *Amarna in Religion und Kunst*, pl. 31; BORCHARDT, *Porträts der Königin Nofret-ete*, p. 9, Abb. 5.

HOUSE O. 49. 13.

Sandstone head from statue of princess, found in débris, in Berlin Mus. 21364, id. op. cit. in *Mitteil. d. Deutsch. Or. Gesell.* No. 50, pp. 24-5, Abb. 16, 17; SCHÄFER, op. cit. in *Amtliche Berichte*, xxxv, p. 139, Abb. 81, reprinted in *Ä.Z.* lii, p. 84, Abb. 20; id. *Kunstwerke aus el-Amarna*, i, pl. 8 (called 9 in text); id. *Amarna in Religion und Kunst*, pl. 25.

HOUSE O. 49. 14.

Coloured statue of King from sculptor's studio, in Cairo Mus., BORCHARDT, op. cit. in *Mitteil. d. Deutsch. Or. Gesell.* No. 50, pls. 2-4, cf. pp. 25-7.

HOUSE P. 49. 6. NAME UNKNOWN. Sculptor's studio.

Plan and view, id. ib. Abb. 20, 21, cf. pp. 29-35.

Sculptor's models of head of Amenophis IV, head of Tut'ankhamūn(?), arms, &c., id. ib. Abb. 23-5, and pl. 5; id. ib. No. 57, pp. 11, 12, Abb. 9, 10; head of Tut'ankhamūn(?), in Berlin Mus. 20496, SCHÄFER, op. cit. in *Amtliche Berichte*, xxxv, p. 135, Abb. 76, reprinted in *Ä.Z.* lii, p. 81, Abb. 15; id. op. cit. in *Berliner Museen Berichte*, xlv (1924), p. 7, Abb. 5; id. *Kunstwerke aus el-Amarna*, i, pl. 1 (called 2 in text); id. *Amarna in Religion und Kunst*, pl. 32; STEINDORFF, *Die Blütezeit des Pharaonenreichs* (1926), p. 163, Abb. 154; WEIGALL, *Anc. Eg. Works of Art*, 190.

HOUSE N. 50. 22.

Fragment of stela, King seated, in Berlin Mus. 22264, BORCHARDT, *Porträts der Königin Nofret-ete*, p. 18, Abb. 14, cf. p. 17, note 4.

HOUSE N. 51. 8.

Painted fragment of floral garland from a corner, id. op. cit. in *Zeitschrift für Bauwesen*, vol. 66 (1916), pl. 50 [2].

L. 50. 12. Great Garden and Shrine.

View of garden, GRIFFITH, *Excavations at El' Amarnah, 1923-24* in *J.E.A.* x, pl. xxxiv [2], cf. p. 303.

Statues (headless) of Amenophis IV and Nefertiti, found in Shrine; King, in Oxford, Ashmolean Mus., id. ib. pl. xxxv, cf. p. 303; id. *Excavations at Tell el-Amarnah, 1923-4* in *J.E.A.* xvii, pl. xxiii, cf. pp. 179-80; Queen, in Brit. Mus., id. ib. pls. xxiv, xxv; see *Guide to the Egyptian Collections* (1930), p. 358.

HOUSE K. 50. 1. NAKHT , Vizier; Governor of the City.

See PEET and WOOLLEY, *The City of Akhenaten*, i, pp. 5-9, pls. v [2-6], viii [1]; WOOLLEY, *Excavations at Tell el-Amarna* in *J.E.A.* viii, pp. 61-4, 65, pls. x, xi [left]. Plan and reconstruction of Central Hall, PEET and WOOLLEY, op. cit. pls. iii, iv; WOOLLEY, op. cit. pl. xvii.

West Loggia.

Remains of texts from niches, GUNN in PEET and WOOLLEY, op. cit. pp. 144-5, figs. 28-9.

Fragments of inscribed jambs, PEET and WOOLLEY, op. cit. pls. vii [4, 6], xxxv [10], cf. GUNN in id. ib. pp. 145-6.

South end of Town.

HOUSE J. 53. I.

Plan, BORCHARDT, op. cit. in *Mitteil. d. Deutsch. Or. Gesell.* Nov. 1911, No. 46, pl. 3 [upper left]; RICKE, *Der Grundriss des Amarna-Wohnhauses*, pl. 22.

Painted framework (?) of window, found in débris, BORCHARDT, op. cit. pl. 5, cf. pp. 23-4; id. *Das altägyptische Wohnhaus* [&c.] in *Zeitschrift für Bauwesen*, vol. 66 (1916), pl. 50 [5] (cf. GLANVILLE in FRANKFORT, *The Mural Painting* [&c.], p. 51 note 2, called Y. 53. 1).

From various parts of the Town.

Lower part of scene, Amenophis IV, Nefertiti, and family, in Louvre E. 11624, PETRIE, *Tell el Amarna*, pl. i [16], cf. pp. 40-1; *Sale Catalogue of the Amherst Collection*, pl. xiii [846]; SCHÄFER, *Kunstwerke aus der Zeit Amenophis' iv* in *Amtliche Berichte*, xxxiv, pp. 137-8, Abb. 70, reprinted in *Ä.Z.* lii, p. 77, Abb. 8; BORCHARDT, *Porträts der Königin Nofret-ete*, p. 26, Abb. 17; see BOREUX, *Guide-Catalogue Sommaire*, ii (1932), pp. 614-15.

Part of architrave, Ipy  adoring names of Amenophis IV and the Aten, in Berlin Mus. 21597, SCHÄFER, *Kunstwerke aus El-Amarna*, ii, pl. 12; id. *Amarna in Religion und Kunst*, pl. 55; texts, *Aeg. Inschr. Mus. Berlin*, ii. 399.

Fragments of reliefs and inscriptions, PEET and WOOLLEY, op. cit. pls. x [1], xii [2-5, 7], xxxv [6-9, 11].

Limestone statuette, Old or Middle Kingdom, found in extreme northern buildings, WHITTEMORE, op. cit. in *J.E.A.* xii, pl. viii. (Given back to Egypt Exploration Society by Cairo Museum in exchange for another, see FRANKFORT, op. cit. in *J.E.A.* xv, p. 149.)

Fragments of statues and trial-pieces from sculptors' studios, PETRIE, op. cit. pl. i [1, 5, 6, 8, 9], cf. pp. 30-1; headless group of King, Queen, and princess [= 1], in London, University College, CAPART, *Rec. de Mon. Ég.* lxxv; BORCHARDT, op. cit. p. 26, Abb. 20.

Two sculptor's trial-pieces, one with head of princess on front and horse's head on back, the other with head of King or Queen, BISSING, *Denkmäler*, 124 [a-c]; horse's head, in Munich, WEIGALL, *Anc. Eg. Works of Art*, 206 [upper left].

Small fragments of frescoes, in London, University College, DAVIES, *Mural Paintings in the City of Akhetaten* in *J.E.A.* vii, pls. iii, iv, cf. pp. 5-6.

Small fragments from sculptors' studios, PETRIE, op. cit. pl. xi [2, 4, 10-12], cf. pp. 30-1.

Fragment with two heads, in London, University College, CAPART, op. cit. lxxiv.

Block from house, with name of Nefertiti, L. *D. Text*, ii, p. 125 [middle lower].

Block from jamb, found in village of El-Till, in Berlin Mus. 2069; cartouche, id. ib. p. 128 [middle]; *Aeg. Inschr. Mus. Berlin*, ii. 222.

Fragment of wall-decoration (?) from remains of a house in El-Till, CHAMPOLLION, *Mon. cccxxxvii bis* [bottom left]; ROSELLINI, *Mon. Civ.* lxx [8], cf. *Text*, ii, p. 390.

(For cuneiform tablets from houses N. 47. 3, and O. 47. 2, see BORCHARDT, op. cit. in *Mitteil. d. Deutsch. Or. Gesell.* Dec. 1914, No. 55, Abb. 12, pls. 6-7, cf. pp. 34-6, 39-45, and another fragment from house O. 49. 23, PEET and WOOLLEY, op. cit. pl. x [7], cf. p. 17.)

RIVER TEMPLE. Re-used Dyn. XX and XXVI.

See id. ib. pp. 125-34, and GUNN in id. ib. pp. 158-60; BORCHARDT, op. cit. in *Mitteil. d. Deutsch. Or. Gesell.* Oct. 1912, No. 50, pp. 8-9; WOOLLEY, op. cit. in *J.E.A.* viii. 65-8. Plan and views, PEET and WOOLLEY, op. cit. pls. xli, xlii.

Altar containing stone with palimpsest cartouches of Ramesses III, id. ib. pl. xlii [2]; WOOLLEY, op. cit. pl. xii [upper], cf. pp. 67-8; BORCHARDT, op. cit. p. 8, Abb. 3.

Fragments of inscribed blocks, PEET and WOOLLEY, op. cit. pls. xxxv [3, 5], xliii, lviii, cf. pp. 158-60.

PALACE CALLED MARU-ATEN  ¹

See WOOLLEY, *Excavations at Tell el-Amarna* in *J.E.A.* viii, pp. 70-82; PEET and WOOLLEY, *The City of Akhenaten*, i, pp. 109-24, cf. GUNN in id. ib. pp. 147-58; BORCHARDT, *Voruntersuchung von Tell el Amarna im Januar 1907 in Mitteil. d. Deutsch. Or. Gesell.* Sept. 1907, No. 34, p. 28. Plan and view, PEET and WOOLLEY, op. cit. pls. xxix, xxxi [1]; WOOLLEY, op. cit. pls. xii [lower], xv.

Entrance Hall. (VIII on plan of PEET and WOOLLEY.)

Restoration of column with scene of Royal family worshipping the Aten, PEET and WOOLLEY, op. cit. pl. xl, cf. p. 113.

Water-Court. (I on plan of PEET and WOOLLEY.)

Painted pavement, id. ib. pls. ix [1], xxxvi [1, 3], xxxviii, xxxix, cf. xxxvii, and pp. 118-19; WOOLLEY, op. cit. pl. xiii [right].

Fragment of pavement, birds and plants, in Berlin Mus. 15335, SCHÄFER, *Kunstwerke aus El-Amarna*, ii, pl. 14; id. *Amarna in Religion und Kunst*, pl. 54; id. op. cit. in *Ämliche Berichte*, xxxiv, pp. 145-6, Abb. 75, reprinted in *Ä.Z.* lii, p. 80, Abb. 13; TIMME, *Tell el-Amarna* [&c.], p. 23, Abb. 24; SCHÄFER and ANDRAE, *Die Kunst des alten Orients*, 365 [upper]; STEINDORFF, *Die Blütezeit des Pharaonenreichs* (1926), Abb. 152 opposite p. 160; part, BORCHARDT, *Die Cyperussäule* in *Ä.Z.* xl, p. 47, Abb. 3.

Fragments of pavement, in Cairo Mus., see BISSING and REACH, *Bericht über die Malerische Technik der Hawata-Fresken* [&c.] in *Ann. Serv.* vii. 64 et seq.

Temple and Kiosks. (II on plan of PEET and WOOLLEY.)

Plan and restoration, PEET and WOOLLEY, op. cit. pl. xxx, cf. pp. 119-22.

Fragments of columns from outer court, and heads of Amenophis IV and Nefertiti from inlay on walls, id. ib. pls. xxxi [5, 6], xxxv [1, 2], cf. pp. 120-1; WOOLLEY, op. cit. in *J.E.A.* viii, pls. xiii [left], xiv [upper].

Fragments of granite and sandstone stelae, PEET and WOOLLEY, op. cit. pls. xxxii [2], xxxiii [2], xxxiv [1, 2], lvi, cf. pp. 121-2; some fragments, WOOLLEY, op. cit. pl. xiv [lower].

Finds.

Fragments of sculptured and inscribed blocks, PEET and WOOLLEY, op. cit. pls. xxxii [1, 3-6], xxxiii [1, 3-5], xxxiv [3-6], xxxv [8, 11], lvii-lxii.

Hieratic graffiti on potsherds (found in building IV on plan of PEET and WOOLLEY); texts and transcriptions, id. ib. pls. lxiii [s, T], lxiv, cf. pp. 117, 164 with note 2.

DESERT ALTARS

Plan and views, FRANKFORT and PENDLEBURY, *The City of Akhenaten*, ii, pls. xxvi, xxvii [1-5], cf. pp. 101-2; rough plan, PETRIE, *Tell el Amarna*, pl. xlii [bottom right], cf. p. 5.

Fragments of red granite bowl of Amenophis III, two fragments of alabaster offering-table of Amenophis IV and Nefertiti, and corner of sandstone offering-table of Amenophis IV, FRANKFORT and PENDLEBURY, op. cit. pls. xlvi [2, 3], cf. pp. 102, 108.

Fragments of relief, id. ib. pl. xxvii [6 a, b], cf. p. 108.

¹ See GUNN in PEET and WOOLLEY, *The City of Akhenaten*, i, p. 156.

WORKMEN'S VILLAGE

See PEET, *Excavations at Tell el-Amarna* [&c.] in *J.E.A.* vii, pp. 175-8, cf. pl. xxvii; WOOLLEY, op. cit. pp. 48-60, pls. vii-ix; PEET and WOOLLEY, op. cit. pp. 51-91, pls. xii [1], xiv, xvii-xxiii. Plan and section, id. ib. pl. xvi; WOOLLEY, op. cit. pl. xvi.

Remains of inscriptions on fragments found in a kitchen, GUNN in PEET and WOOLLEY, op. cit. pp. 146-7.

Painted pilaster, PEET and WOOLLEY, op. cit. pl. ix [2].

Hieratic graffiti on potsherds, id. ib. pl. lxiii [A-M], cf. p. 164.

TOMB CHAPELS

Some probably temp. Smenkhkarē' and Tut'ankhamūn.

See PEET, op. cit. in *J.E.A.* vii. 179-82; PEET and WOOLLEY, op. cit. pp. 92-108, pl. xiv [2, 5, 6]. Plans, id. ib. pls. xxiv, xxv. Views, id. ib. pl. xxvii; PEET, op. cit. pl. xxviii.

No. 525.

Plan and section, PEET and WOOLLEY, op. cit. pl. xxv [upper]; PEET, op. cit. in *J.E.A.* vii, fig. on p. 180. Reconstruction, PEET and WOOLLEY, op. cit. pl. xxvi. Elevation of shrine, *Tomb-Chapel 525 at Tell El-Amarnah* in *J.E.A.* xi, pl. vi, cf. p. 36.

Shrine.

Inscribed entablature; fragments with name of Amūn, PEET and WOOLLEY, op. cit. p. 96, fig. 14.

Stelae with prayers to Shed and Isis, one of Ptaḥmey , found in niche, id. ib. pl. xxviii, cf. pp. 96-7; stela of Ptaḥmey, PEET, op. cit. in *J.E.A.* vii, pl. xxix [3].

No. 529.

Inner Court.

Jamb with name of Amūn, PEET and WOOLLEY, op. cit. p. 95, fig. 13.

Statue-base with name of Neḥem-maatiu , Servant in the Place; text, id. ib. p. 101, fig. 15.

No. 551.

Shrine.

Painted vine decoration on ceiling, id. ib. pl. xxxvi [2].

ROCK-TOMBS ¹

Complete, DAVIES, *The Rock Tombs of El Amarna*, six vols. passim; south group, BOURIANT, LEGRAIN and JÉQUIER, *Les Tombes de Khouitatonou* in *Mém. Inst. Fr. Arch. Or.* viii, pp. 25-129, pls. xv-lxv. Map showing positions, PETRIE, *Tell el Amarna*, pl. xxxv; see DAVIES, op. cit. ii, pl. i; of south group, BOURIANT, &c., op. cit. pl. xiv. General description, SAINT-FERRIOL MSS.* Diary, May 9-10, 1842.

North Group.

I A. REDU .

Plan, section, and elevation, DAVIES, op. cit. ii, pl. xlii [left]. View, id. ib. pl. xxiv [upper left], cf. p. 3.

Façade.

Text above entrance, id. ib. pl. xlii [middle]; *L. D. Text*, ii, p. 141 γ.

¹ The marginal tomb-numbers are those of PETRIE and DAVIES.

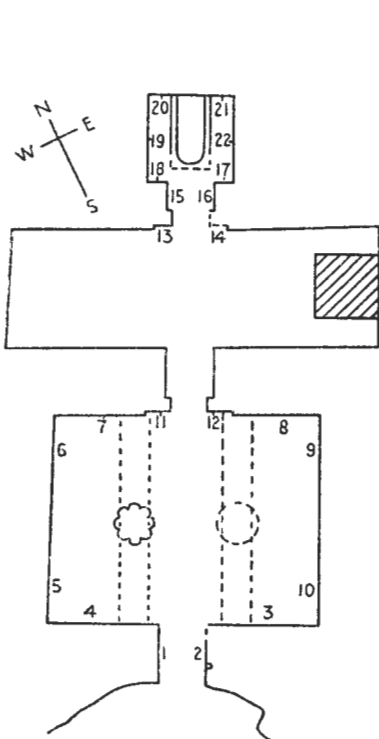

Tomb 1. Ḥuya. From DAVIES, iii, pl. i.

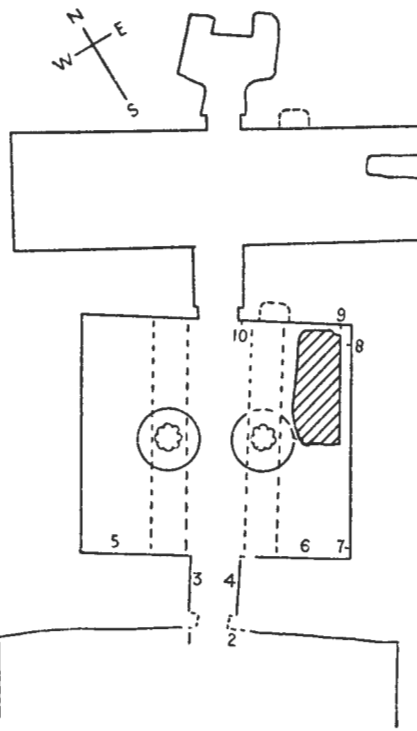

Tomb 2. Meryrē II. From DAVIES, ii, pl. xxviii.

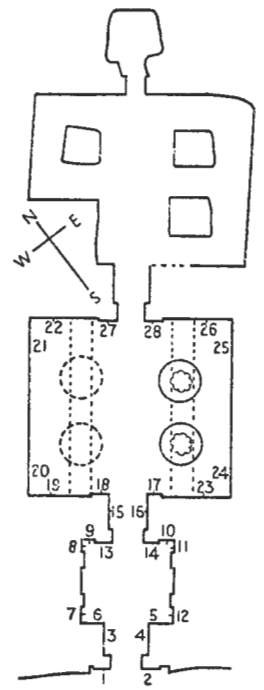

Tomb 4. Meryrē I. From DAVIES, i, pl. i.

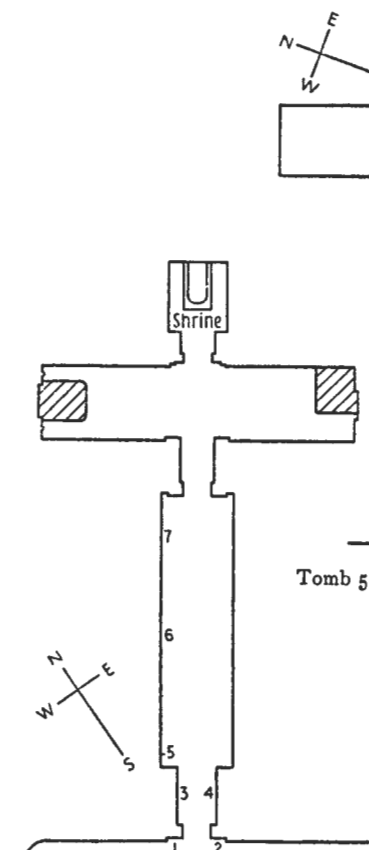

Tomb 3. Aḥmosi. From DAVIES, iii, pl. xxvi.

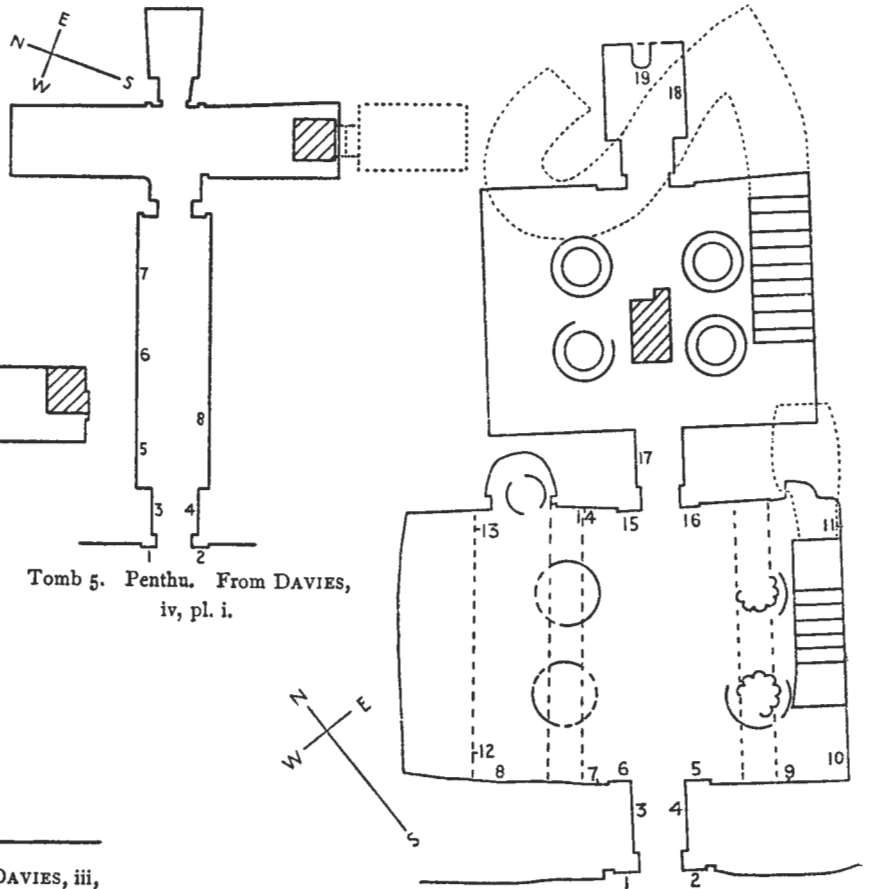

Tomb 6. Panehesi. From DAVIES, ii, pl. ii.

All these plans are from DAVIES, *The Rock Tombs of El Amarna*.

I. HUYA , Overseer of the Royal Harim and of the Two Treasuries, and Steward, of the Great Royal Wife Teye.

DAVIES, op. cit. iii, pls. ii-xxv, xxxvi-xxxvii, and pp. 1-19. Plan and sections, id. ib. pl. i; HAY*, 29847, 47 verso; sketch-plan, NESTOR L'HÔTE MSS.* 20396, 277 [top left].

Entrance.

(1) Thickness, deceased and hymn to the Aten, DAVIES, op. cit. iii, pls. iii, xxxvii [right]; titles, L. D. iii. 100 e, and *Text*, ii, p. 138 β.

(2) Thickness, deceased and hymn to the Aten, DAVIES, op. cit. iii, pls. ii, xxxvii [left], cf. pp. 17-18; BOURIANT, LEGRAIN and JÉQUIER, op. cit. pp. 59-60 with fig. 24 (assigned to unfinished tomb 21, but see DAVIES, op. cit. v, p. 14, note 2); NESTOR L'HÔTE MSS.* 20396, 277 [bottom left]; titles, L. D. *Text*, ii, p. 138 a.

Ceiling. Text, DAVIES, op. cit. iii, p. 2 [A].

Hall.

(3) Upper part, Amenophis IV, Nefertiti, and Princesses Merytaten and Nefer-neferuaten (probably) at table with Teye and her daughter Beketaten, lower part, two registers, fan-bearers, musicians, officials, &c., and base, peasants in the fields, DAVIES, op. cit. iii, pls. iv, v, cf. p. 6; AMÉLINEAU, *Histoire de la Sépulture et des Funérailles dans l'Ancienne Égypte*, ii, in *Ann. Mus. Guimet*, xxix, pl. c opposite p. 646 (from papers of NESTOR L'HÔTE); NESTOR L'HÔTE MSS.* 20404, 12; upper part, and part of upper register of lower part, PRISSE, *L'Art Égyptien*, ii, *Sculpture*, pl. 27 'Offrandes au Soleil', cf. *Texte*, pp. 405-6; upper part, L. D. iii. 100 c, cf. *Text*, ii, p. 139 [middle]; two servants, NESTOR L'HÔTE MSS.* 20412, B (squeeze); the two princesses, WILKINSON MSS.* ii. 45 verso [3 right]; musicians from upper register of lower part, NESTOR L'HÔTE MSS.* 20412, 1 (squeeze); text (now destroyed) of deceased tasting food, from upper register (cf. DAVIES, p. 6), L. D. iii. 100 d, and *Text*, ii, p. 139 [bottom]; two foreigners with musical instruments from lower register, WILKINSON, *M. and C.* ii. 281 (No. 212), 290 (No. 216) = ed. BIRCH, i. 470 (No. 237), 476 (No. 241); WILKINSON MSS.* ii. 45 verso [4 left].

(4) Upper part, Teye with daughter Beketaten drinking wine with King, Queen, and Princesses 'Ankhesenpa-aten and Merytaten (?), and deceased and two servants, lower part, two registers, courtiers, musicians, food, lamp-stands, &c., DAVIES, op. cit. iii, pls. vi, vii [lower]; AMÉLINEAU, op. cit. pl. ci opposite p. 648 (from papers of NESTOR L'HÔTE); NESTOR L'HÔTE MSS.* 20404, 10; Beketaten, deceased, and man in front of him, id. ib. 20412, D, E, G (squeezes); text of Teye, and names of Beketaten and 'Ankhesenpa-aten, L. D. *Text*, ii, p. 139 [top].

(5)-(6) King [and Queen] in palanquin followed by princesses receive tribute from Syria and Ethiopia at the palace, and base, peasants ploughing, sailing-boat, &c., DAVIES, op. cit. iii, pls. xiii-xv, vii [upper], and p. 10; see BURTON MSS.* 25636, 23; omitting base, AMÉLINEAU, op. cit. pl. ciii between pp. 652 and 653 (from papers of NESTOR L'HÔTE); HAY*, 29814, 45, 46, 59; WILKINSON MSS.* iii. 36; NESTOR L'HÔTE MSS.* 20404, 7; upper part, King in palanquin, L. D. iii. 100 b, cf. *Text*, ii, p. 140 [middle]; loggia at north end, NESTOR L'HÔTE, *Lettres écrites d'Égypte*, 69; one chariot, WILKINSON, *M. and C.* i. 46 (No. 4) = ed. BIRCH, i. 33 (No. 3); part of fifth to seventh registers, man with chariot and captives, and tribute from south with negroes bringing gold-rings, negro women and children, antelopes, &c., BURTON MSS.* 25634, 101, 102; negro prisoners from fifth register, negroes bringing tribute from sixth register, and Asiatic prisoners from north end of sixth and seventh registers, MEYER, *Darstellungen der Fremdvölker*, 55, 56, 54.

(7) Upper part, deceased rewarded by King with Queen in balcony, lower part, deceased superintends registration of treasure, DAVIES, op. cit. iii, pl. xvi; King and Queen, VYSE, *Operations carried on at the Pyramids of Gizeh*, i, p. 111 (inaccurate); NESTOR L'HÔTE MSS.* 20396, 276 verso, 20404, 85.

(8) Upper part, deceased wearing decorations before King and Queen, lower part, chariot of deceased and servants, and workshops below, including studio of Iuti , Overseer of sculptors of the Great Royal Wife Teye, DAVIES, op. cit. iii, pls. xvii, xviii [lower]; studio with sculptors at work on statue of Beketaten, L. D. iii. 100 a; NESTOR L'HÔTE MSS.* 20405, 70, 74 (squeezes).

(9)-(10) Upper part, King and Teye followed by her daughter Beketaten and courtiers visit Aten-Temple, lower part, two registers, standard-bearers, chariots, and deceased followed by servants, with marsh-scene at base, DAVIES, op. cit. iii, pls. viii, ix-xii, cf. xxv [G], pp. 8, 19-25; AMÉLINEAU, op. cit. in *Ann. Mus. Guimet*, xxix, pl. cii between pp. 650 and 651 (from papers of NESTOR L'HÔTE); HAY*, 29814, 42; NESTOR L'HÔTE MSS.* 20404, 4; upper part, L. D. iii. 101, 102, cf. *Text*, ii, pp. 139-40; deceased with followers from second register, PETRIE, *Racial Types*, 612 on sheet xiv; NESTOR L'HÔTE MSS.* 20412, J (squeeze); text above followers, L. D. *Text*, ii, p. 141 [top]; sketches of parts of Temple and base, BURTON MSS.* 25636, 22 [bottom].

(11)-(12) Inner doorway. Lintel, double-scene, Amenophis IV with Nefertiti and four princesses, and Amenophis III with Teye, Beketaten and attendants, worship the Aten, jambs, texts with deceased kneeling at bottom, DAVIES, op. cit. iii, pls. xviii [upper], xxi [middle], xxvii [middle], cf. xxxvi [left]; deceased kneeling from left jamb, NESTOR L'HÔTE MSS.* 20396, 277 [bottom right]; two fragments of text, L. D. *Text*, ii, p. 141 [Abdruck 132]; Greek graffiti including figures of Anubis, DAVIES, op. cit. iii, pl. xxv [B, D, E], cf. p. 3.

Ceiling. Decoration including soffits of architraves, id. ib. pl. xxv [A, F]. Text, id. ib. p. 2 [B].

Entrance to Shrine.

(13)-(14) Doorway, id. ib. pls. xix, xxxvi [right], cf. pp. 18-19; shewing statue inside, NESTOR L'HÔTE MSS.* 20396, 275, 277 [top middle]; sketch, WILKINSON MSS.* ii. 45 verso [6]; AMÉLINEAU, op. cit. in *Ann. Mus. Guimet*, xxviii, p. 322 (from papers of NESTOR L'HÔTE); lower line of lintel-text, L. D. *Text*, ii, p. 141 [upper middle].

(15) and (16) Thicknesses; deceased with prayer on each side, DAVIES, op. cit. iii, pl. xx, cf. p. 18.

Shrine.

(17) and (18) Sister and wife (?) of deceased kneeling on each side, id. ib. pl. xxi [left and right]; names and titles, L. D. iii. 100 f, g, and *Text*, ii, p. 141 a, b.

(19) Four registers, funeral procession (lower part destroyed), DAVIES, op. cit. iii, pl. xxiii.

(20) and (21) Funeral furniture on either side of statue of deceased; omitting statue, id. ib. pl. xxiv.

(22) Funeral rites before mummy, and sacrificial oxen and mourners below, id. ib. pl. xxii.

Ceiling. Decoration, id. ib. pl. xxv [K].

2. MERYRĒ II , Royal scribe; Steward; Overseer of the Two Treasuries; Overseer of the Royal Harim of the Great Royal Wife Nefertiti.

Complete, DAVIES, op. cit. ii, pls. xxix-xli, xlvi, xlvi, pp. 33-45. Plan and sections, id. ib. pl. xxviii; plan, NESTOR L'HÔTE MSS.* 20404, 14 [lower]. View, DAVIES, op. cit. ii, pls. xxiv [right upper], xlvi [left].

Façade.

(1) and (2) Jambs, remains of prayers to the Aten with deceased kneeling below on west side, *id. ib. pl. xxix* [lower], *cf. p. 45*.

Entrance.

(3) Thickness, deceased adores the Aten (destroyed), *id. ib. pl. xxxi*, *cf. p. 45*; NESTOR L'HÔTE MSS.* 20396, 291, *cf. 20411* (1), U (squeeze); cartouche and title above deceased, *L. D. Text*, ii, p. 137 β .

(4) Thickness, deceased and hymn to the setting Aten, DAVIES, *op. cit. ii*, pl. xxx, *cf. pp. 44-5*; NESTOR L'HÔTE MSS.* 20396, 290 [lower], 20411 (1), V, X (squeezes); titles of deceased, *L. D. Text*, ii, p. 137 α ; HAY*, 29847, 63 [near top, right].

Hall.

View, DAVIES, *op. cit. ii*, pl. xlvi [left].

(5) Nefertiti with Princesses Merytaten, Meketaten, and 'Ankhesenpa-aten, fills King's cup, with female musicians and deceased tasting wine below, *id. ib. pls. xxxii, xlvi* [right]; PRISSE, *L'Art Égyptien*, ii, *Sculpture*, pl. 16 'Le pharaon Khouenaten servi par la reine', *cf. Texte*, p. 401; AMÉLINEAU, *op. cit. in Ann. Mus. Guimet*, xxix, pl. xcv opposite p. 636 (from papers of NESTOR L'HÔTE); NESTOR L'HÔTE MSS.* 20404, 9; Royal family, *L. D. iii. 98 b*; King and Queen, NESTOR L'HÔTE, *Lettres écrites d'Égypte*, 66; frieze of uraei, text above Queen, and musicians, &c., below, *id. MSS.* 20411* (1), O, N, M (squeezes); musicians, WILKINSON MSS.* ii. 45 verso [9]; floral column of kiosk, PRISSE, *op. cit. i, Architecture*, pl. 18 [1] 'Constructions en bois—colonnets des édicules', *cf. Texte*, pp. 362-3.

(6) Upper part, deceased rewarded before King and Queen with five princesses in balcony of palace, and foreigners, chariots, scribes, and escort, lower part, deceased welcomed at home, DAVIES, *op. cit. ii*, pls. xxxiii-xxxvi [upper], xlvi [right]; AMÉLINEAU, *op. cit. pl. xciv* opposite p. 634 (from papers of NESTOR L'HÔTE); omitting lower part and top register of courtiers on right, NESTOR L'HÔTE MSS.* 20404, 15; princesses with collars and text above, and deceased receiving collars, *id. ib. 20411* (1), Q, P (squeezes); the foreign ambassadors, MEYER, *Darstellungen der Fremdvölker*, 57; design of captives on balcony, NESTOR L'HÔTE, *Lettres écrites d'Égypte*, 70; *id. MSS.* 20396*, 130-1 (tracing); names of princesses, *L. D. Text*, ii, p. 138 [middle].

(7)-(8) King and Queen with six princesses receive six registers tribute from nations, with three registers men with tribute, royal palanquins, chariots, military escort, and servants with oxen, &c., below, DAVIES, *op. cit. ii*, pls. xxxvii-xl, xlvi [left]; AMÉLINEAU, *op. cit. in Ann. Mus. Guimet*, xxix, pl. xcvi between pp. 638 and 639 (from papers of NESTOR L'HÔTE); HAY*, 29814, 47, 48; NESTOR L'HÔTE MSS.* 20404, 3; six registers Nubian tribute, and courtiers, men with bouquets, soldiers, and bulls, from two bottom registers, and royal palanquin, *id. ib. 20411* (1), H, E, J, K, L (squeezes); Royal family in kiosk, *L. D. iii. 99 b*, *cf. Texte*, ii, p. 137 with note; text above kiosk, and texts of princesses, HAY*, 29847, 64 [middle]; text of year [12] on right of kiosk (reversed), DAVIES, *op. cit. ii*, pl. xxix [upper right], *cf. p. 38*; north side, Asiatics leading animals from top and second registers, MEYER, *op. cit. 65*; Asiatics from third and fourth registers, *id. ib. 63, 64*; sixth and seventh registers, negroes and Asiatics, *id. ib. 61, 62*; eighth and ninth registers, Libyans and Asiatics with tribute, *id. ib. 58-60*; south side, mock battle from fifth register, DAVIES, *The Graphic Work of the Expedition in N. Y. Metro. Bull.* Pt. ii, Dec. 1923, p. 51, fig. 19.

(9)-(10) Deceased rewarded before Amenophis IV and Nefertiti (cartouches replaced by Smenkhkaré' and Merytaten) beneath Aten-rays with palace behind, DAVIES, *The*

Rock Tombs of El Amarna, ii, pl. xli; NESTOR L'HÔTE MSS.* 20404, 14 [upper]; part, L. D. iii. 99 a; deceased rewarded, and four of the cartouches at top of scene, NESTOR L'HÔTE MSS.* 20411 (1), R, S (squeezes); texts and palace, HAY*, 29847, 63 [bottom], 64 [top left]; cartouches, L. D. *Text*, ii, p. 138 [top]; PRISSE, *Mon.* p. 3 [upper].

Architraves. Texts, DAVIES, op. cit. ii, pl. xxxvi [lower], cf. xxix [upper left] and p. 45.

3. AḤMOSI , Real royal scribe; Fan-bearer on the right of the King; Steward of the House of Akhenaten; Overseer of the Judgement-hall; &c. (See plan, supra p. 210.)

Complete, DAVIES, *The Rock Tombs of El Amarna*, iii, pls. xxvii-xxxiv, xxxviii, xxxix, pp. 26-33. Plan and sections, id. ib. pl. xxvi.

Façade.

(1)-(2) Doorway. Lintel, deceased at each end adores Aten-cartouches, jambs, burial petitions, id. ib. pl. xxvii [top, right and left], cf. p. 32; NESTOR L'HÔTE MSS.* 20396, 289.

Entrance.

(3) Thickness, deceased and hymn to the rising Aten, DAVIES, op. cit. iii, pl. xxix, cf. pp. 31-2; BURTON, *Excerpta Hiero.* vii; id. MSS.* 25634, 95-9, 104; NESTOR L'HÔTE MSS.* 20396, 287; deceased and ll. 9-10 of hymn, id. *Lettres écrites d'Égypte*, 75.

(4) Thickness, deceased and hymn to the setting Aten, DAVIES, op. cit. iii, pls. xxviii, xxxviii [right], cf. p. 31; L. D. iii. 98 a; NESTOR L'HÔTE MSS.* 20396, 288.





Passage.

(5)-(7) Upper part, visit to Temple; Temple, military escort, and sketch of King and Queen in chariot, DAVIES, op. cit. iii, pls. xxx-xxxii [A], xxxix; incomplete, NESTOR L'HÔTE MSS.* 20396, 286 verso [upper]; two upper registers of soldiers, STEINDORFF, *Die Blütezeit des Pharaonenreichs* (1900), p. 155, Abb. 130; part, WRZINSKI, *Atlas*, ii. 13; MEYER, *Darstellungen der Fremdvölker*, 66-7; SCHÄFER and ANDRAE, *Die Kunst des alten Orients*, 363 [upper]; some soldiers, and text of the Aten at top, BURTON MSS.* 25634, 100, 103 [upper]; some soldiers, HAY*, 29843, 168.

(5) Lower part, palace, and Royal family at table, with attendants and tables below, DAVIES, op. cit. iii, pls. xxxiii, xxxiv; omitting attendants, HAY*, 29814, 26; Royal family and text above, NESTOR L'HÔTE MSS.* 20396, 286 [bottom], 286 verso [lower]; text above, BURTON MSS.* 25634, 103 [lower]; union-symbol on King's throne, L. D. *Text*, ii, p. 136 [top].

Shrine.

View showing entrance and statue, DAVIES, op. cit. iii, pl. xxxviii [left], cf. xxvii [bottom middle].

4. MERYRĒ' I  (, , , &c.), High Solar priest of the Aten in the Temple of the Aten in Akhetaten; Fan-bearer on the right of the King; Chancellor of the King of Lower Egypt; &c. (See plan, supra p. 210.)

Complete, DAVIES, *The Rock Tombs of El Amarna*, i, passim. Plan and sections, id. ib. pls. i, ii; HAY*, 29847, 45 verso; plan and notes, NESTOR L'HÔTE MSS.* 20396, 282; plan, AMÉLINEAU, op. cit. in *Ann. Mus. Guimet*, xxviii, p. 316 (from papers of NESTOR L'HÔTE); sketch-plan, L. D. *Text*, ii, p. 133. Views, DAVIES, op. cit. i, pl. iii.

Façade.

(1) and (2) Lintel, deceased kneeling at each end adores Aten-cartouches, jambs, cartouches and deceased kneeling with hymns at bottom; left jamb, and remains of deceased with hymn from bottom of right jamb, id. ib. pls. xl [middle], xxxv [middle lower], cf. p. 9; remains of text on left jamb, NESTOR L'HÔTE MSS.* 20396, 284.

Entrance to Antechamber.

(3) and (4) Thicknesses, deceased with hymn on each, DAVIES, op. cit. i, pls. xli, iv [middle], cf. pp. 48-9; NESTOR L'HÔTE MSS.* 20396, 282 verso, 283 [left]; titles, L. D. *Text*, ii, p. 133 [bottom].

Ceiling. Decoration, DAVIES, op. cit. i, pl. xxxix [middle]; NESTOR L'HÔTE MSS.* 20396, 284 verso, 20404, 19.

Antechamber.

(5) and (6) Figures of deceased with hymn, DAVIES, op. cit. i, pl. xxxviii, cf. p. 49; scene at (5), NESTOR L'HÔTE MSS.* 20396, 283 [right].

(7), (9), (10), (12) Panel with cartouches, DAVIES, op. cit. i, pl. xl [A]; BURTON MSS.* 25634, 94 [right], 25636, 22 [left].

(8), (11) Decorative floral panel, DAVIES, op. cit. i, pl. xl [B].

Entrance to Pillared Hall.

(13)-(14) Doorway. Lintel, remains of Aten-cartouches with deceased kneeling at each end, jambs, burial-petitions, id. ib. pl. xxxix [left and right], cf. pp. 52-3; deceased kneeling at right end, HAY*, 29814, 35; jambs, NESTOR L'HÔTE MSS.* 20396, 283 verso.

(15) Thickness, wife Tenro , Great favourite of the Lady of the Two Lands, adoring, DAVIES, op. cit. i, pls. iv [right], xxxvi, cf. pp. 49-50; L. D. iii. 97 a; AMÉLINEAU, op. cit. in *Ann. Mus. Guimet*, xxix, pl. xcii [left] opposite p. 630 (from papers of NESTOR L'HÔTE); HAY*, 29814, 27; NESTOR L'HÔTE MSS.* 20404, 27 [middle]; omitting text, BURTON MSS.* 25634, 75, 77.

(16) Thickness, deceased adoring, DAVIES, op. cit. i, pls. iv [left], xxxvii, cf. pp. 50-2; AMÉLINEAU, op. cit. pl. xcii [right] opposite p. 630 (from papers of NESTOR L'HÔTE); NESTOR L'HÔTE MSS.* 20404, 27 [right]; WILKINSON MSS.* ii. 45 verso [21]; HAY*, 29814, 36; omitting text, BURTON MSS.* 25634, 74, 76.

Pillared Hall.

(17)-(18) Doorway. Lintel, deceased kneeling with hymn at each end adores Aten-cartouches, jambs, cartouches and deceased kneeling with hymn at bottom, DAVIES, op. cit. i, pl. xxxv [top, left and right], cf. p. 52; NESTOR L'HÔTE MSS.* 20404, 18 [right]; deceased with texts at bottom of right jamb, id. 20410 (4), s' (squeeze).

(19) Upper part, deceased with escort invested as High priest of the Aten before King and Queen in balcony, lower part, remains of scene of deceased received by household, DAVIES, op. cit. i, pls. vi-ix; upper part, NESTOR L'HÔTE MSS.* 20404, 26; courtiers and deceased carried, L. D. iii. 97 b.

(20)-(21) Royal family with attendants in chariots leave palace for Temple with military escort, and base, soldiers, runners, and chariots, DAVIES, op. cit. i, pls. x, xv-xx; L. D. iii. 92, 93; WILKINSON MSS.* iii. 37; HAY*, 29814, 21-5, 55, 60; NESTOR L'HÔTE MSS.* 20404, 17, 33; part of top row of soldiers preceding royal chariot, MEYER, *Darstellungen der Fremdvölker*, 69; WRESZINSKI, *Atlas*, ii. 12; text above royal chariots, BURTON MSS.* 25634, 65; Aten-rays with cartouches, and various soldiers, NESTOR L'HÔTE MSS.* 20410 (4), o', t', r', l' (squeezes).

(22) Officials waiting to receive Royal family at Temple, DAVIES, op. cit. i, pls. x A-xiv; L. D. iii. 94; NESTOR L'HÔTE MSS.* 20410 (3), T, U, V, X (squeezes); HAY*, 29814, 30 [right], 31, 51, 52; omitting Temple, NESTOR L'HÔTE MSS.* 20404, 32 [left]; part of Temple with flag-staffs and first pylon, WILKINSON MSS.* x. 44.

(23) Upper part, King and Queen, with Princesses Merytaten and Meketaten, offering to the Aten, and base, two registers, courtiers, priests, chariots, and musicians, DAVIES, op. cit. i, pls. xxi-xxiv; NESTOR L'HÔTE MSS.* 20404, 18 [left]; omitting bottom register, id. 20410 (1), I, J (squeezes); upper part, WILKINSON, *M. and C.* 2 Ser. Supp. pl. 30 = ed. BIRCH, iii, pl. xxiii opposite p. 52; WILKINSON MSS.* ii. 46 [upper]; HAY*, 29814, 29, 30 [left]; BURTON MSS.* 25634, 86, 91, 93 verso; female fan-bearers, charioteer and four fan-bearers, and musicians, NESTOR L'HÔTE MSS.* 20410 (1), D, E, F (squeezes); one chariot, four fan-bearers, and musicians, WILKINSON MSS.* ii. 18 verso [left and middle]; blind musicians, PRISSE, *Mon.* xv bis [1]; WILKINSON, *M. and C.* ii. 239 (No. 193) = ed. BIRCH, i. 442 (No. 218); STEINDORFF, *Die Blütezeit des Pharaonenreichs* (1900), p. 159, Abb. 134; (1926), p. 186, Abb. 176; DAVIES, *The Graphic Work of the Expedition in N.Y. Metro. Bull.* Pt. ii, Dec. 1923, p. 47, fig. 11 [lower].

(24)-(26) Upper part, King, Queen, and four princesses worship in the Temple, with chariots and escort in attendance, and palace at south end, DAVIES, *The Rock Tombs of El Amarna*, i, pls. xxv [upper], xxvi-xxviii, xxxiii, v [left]; omitting part on north wall, AMÉLINEAU, op. cit. in *Ann. Mus. Guimet*, xxix, pl. lxxxv [upper] between pp. 612 and 613 (from papers of NESTOR L'HÔTE); NESTOR L'HÔTE MSS.* 20404, 8 [upper]; Temple buildings, L. D. iii. 96 a, c; part, PRISSE, *L'Art Égyptien*, i, *Architecture*, pl. 41 'Plans cavaliers des édifices de Tell el-Amarna', cf. *Texte*, p. 375; north end of Temple with hall of statues, part of storehouse, altar, and great pylon, HAY*, 29814, 54, 57, 56, 38; hall of statues (on north wall), WILKINSON, *M. and C.* ii. 102 (No. 96, 2) = ed. BIRCH, i. 346 (No. 115, 2); heads and texts of two princesses, L. D. iii. 97 c, and *Text*, ii, p. 134 a; soldiers and foreign ambassadors, L. D. iii. 97 d; MEYER, op. cit. 68; WRESZINSKI, *Atlas*, ii. 11; one archer (reversed), DAVIES, op. cit. in *N.Y. Metro. Bull.* Pt. ii, Dec. 1923, p. 48, fig. 13 [left]; palace at south end, L. D. iii. 96 b. Lower part, deceased rewarded by King in front of Temple treasury, with storehouses, garden, &c., and cattle-yards, waiting chariots, and laden boats, at south end, DAVIES, *The Rock Tombs of El Amarna*, i, pls. xxv [lower], xxix-xxxii, v [right], cf. p. 53; omitting part on north wall, AMÉLINEAU, op. cit. pl. lxxxv [lower] between pp. 612 and 613 (from papers of NESTOR L'HÔTE); NESTOR L'HÔTE MSS.* 20404, 8 [lower]; decoration of deceased before Royal family, L. D. iii. 97 e; deceased decorated, NESTOR L'HÔTE, *Lettres écrites d'Égypte*, 61 (reversed); text above deceased, BURTON MSS.* 25634, 92, 93; garden, stables, storehouses, and granaries, WILKINSON, *M. and C.* ii, pls. ix between pp. 132 and 133, v [1] opposite p. 94, and p. 105 (No. 97, 2) = ed. BIRCH, i, pls. ix opposite p. 368, vi [1] opposite p. 340, and p. 348 (No. 116, 2); BURTON MSS.* 25634, 78-84; omitting granaries, PRISSE, *L'Art Égyptien*, i, *Architecture*, pls. 39 [lower] 'Plans cavaliers des édifices de Tell el-Amarna', 40 'Plan cavalier d'une villa royale', cf. *Texte*, pp. 372-4; L. D. iii. 95; HAY*, 29814, 53, 43; NESTOR L'HÔTE MSS.* 20410 (3), Y, (4), Z, A' (squeezes); sketch of part of storehouses and gardens, WILKINSON MSS.* x. 45-8; doorway with column from storehouse, id. *M. and C.* ii. 102 (No. 95, 2) = ed. BIRCH, i. 346 (No. 114, 2); cattle-yards, chariots, and boats, HAY*, 29814, 44; one chariot, PRISSE, op. cit. ii, *Sculpture*, pl. 22 'Char princier', cf. *Texte*, p. 403; cattle-yards, WILKINSON, *M. and C.* ii. 134 (No. 120, 1) = ed. BIRCH, i. 370 (No. 140, 1); boats, WILKINSON MSS.* ii. 22 A; three soldiers with lantern by boats, id. *M. and C.* iii. 113 (No. 352) = ed. BIRCH, ii. 157 (No. 385).

Columns.

Two columns with abacus text, HAY*, 29847, 46, 63 [near bottom]; see DAVIES, op. cit. i, pl. ii, cf. p. 15; one column, NESTOR L'HÔTE MSS.* 20404, 27 [left]; texts of abaci (incomplete), CHAMPOLLION, *Not. Descr.* ii. 319.

Text from south column of east pair, DAVIES, op. cit. i, pl. xxxv [middle upper], cf. ii [right upper].

Entrance to Inner Hall.

(27)–(28) Doorway. Lintel, deceased kneeling with hymn at each end adores Aten-cartouches, jambs, texts with name of Meryrē' substituted for that of Ḥatiay , id. ib. i, pl. xxxiv, cf. pp. 15–16, 52, 53; lintel, NESTOR L'HÔTE MSS.* 20410 (1), A, E, G, H (squeezes), 20404, 32 [right]; right jamb, id. ib. 20396, 285.

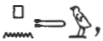
5. PENTHU , Royal scribe; First under the King; Chief servitor of the Aten in the Residence of the Aten in Akhetaten; Chief physician; &c. (See plan, supra p. 210.)

Complete, DAVIES, *The Rock Tombs of El Amarna*, iv, pls. ii–xii, pp. 1–6. Plan and sections, id. ib. pl. i; plan, AMÉLINEAU, op. cit. in *Ann. Mus. Guimet*, xxviii, p. 315 (from papers of NESTOR L'HÔTE); NESTOR L'HÔTE MSS.* 20396, 281 verso [bottom]; BURTON MSS.* 25636, 20 [left].

Façade.

(1)–(2) Lintel, deceased at each end adores Aten-cartouches, jambs, burial petition; ends of lintel, and jambs, DAVIES, op. cit. iv, pl. ii, cf. p. 30; cartouches from lintel, NESTOR L'HÔTE MSS.* 20396, 293 verso.

Entrance.

(3) Thickness, deceased and hymn to the Aten, DAVIES, op. cit. iv, pl. iii, cf. p. 29; NESTOR L'HÔTE MSS.* 20396, 294; name and titles, L. D. *Text*, ii, p. 132 a; part, L. D. iii. 91 q.

(4) Thickness, deceased and hymn to the Aten, DAVIES, op. cit. iv, pl. iv, cf. pp. 29–30; NESTOR L'HÔTE MSS.* 20396, 293.

Passage.

(5)–(6) Upper part, King and Queen with three princesses, attendants, and chariots, worshipping before Aten-Temple, DAVIES, op. cit. iv, pls. v–vi [left], xi [left]; King, Queen, and part of Temple, BURTON MSS.* 25634, 87, 88, 25636, 22 [middle]; texts above princesses, NESTOR L'HÔTE MSS.* 20396, 281 verso [middle]; fragment, two female fan-bearers, in Berlin Mus. 521, DAVIES, op. cit. iv, pl. ii [middle], cf. p. 2, note 3; see L. D. *Text*, ii, p. 133; *Ausführ. Verzeichnis* (1899), p. 205. Lower part, chariots, gardens, freight-ships, and deceased as chancellor rewarded before Royal family, DAVIES, op. cit. iv, pls. viii [upper], ix [A–C, E].

(7) Upper part, deceased rewarded before King and Queen in front of Lesser Sanctuary of Temple, lower part, remains of tending cattle, id. ib. pls. vi [right], vii, xii [D], ix [D].

(8) Upper part, remains of scene of King and Queen at table, lower part, deceased as chief physician rewarded before King in palace, id. ib. pls. x, viii [lower].

6. PANEḤESI  Chief servitor of the Aten in the Residence of the Aten in Akhetaten; Second prophet, and Servitor, of the Lord of the Two Lands Neferkheprure' in the Temple of the Aten; Overseer of the granary and of the cattle of the Aten; Chancellor of the King of Lower Egypt; &c. (See plan, supra p. 210.)

Complete, DAVIES, *The Rock Tombs of El Amarna*, ii, pls. iv-xxiii, xxvi, xxvii, pp. 9-32. Plan and sections, id. ib. pls. ii, iii; plan, section, and elevation, HAY*, 29847, 12 verso-13; plan, AMÉLINEAU, op. cit. in *Ann. Mus. Guimet*, xxviii, p. 317 (from papers of NESTOR L'HÔTE); NESTOR L'HÔTE MSS.* 20396, 279 verso [lower], 281 [left]; BURTON MSS.* 25636, 20 [middle].

Façade.

(1)-(2) Lintel, double-scene, King, Queen, and three princesses worship the Aten, with Queen's sister Mutbenret  and attendants, and nurse and two female dwarfs, jambs, two registers, Royal family worshipping on each side (right one much destroyed), DAVIES, op. cit. ii, pls. v [upper], vi [left, right], cf. p. 30; lintel, NESTOR L'HÔTE MSS.* 20404, 36 [left], 20396, 280 [right]; names of female dwarfs, and title of Queen's sister, L. D. *Text*, ii, p. 131 [top]; lower scene on left jamb, NESTOR L'HÔTE MSS.* 20410 (2), 0 (squeeze).

Entrance to Outer Hall.

(3) Thickness, Royal family worship the Aten, with attendants and Queen's sister Mutbenret below, and deceased with hymn at bottom, DAVIES, op. cit. ii, pls. vii, xxvii [right], cf. pp. 29-30; AMÉLINEAU, op. cit. in *Ann. Mus. Guimet*, xxix, pl. lxxxiv opposite p. 610 (from papers of NESTOR L'HÔTE); NESTOR L'HÔTE MSS.* 20404, 35 [left], 20396, 297 verso; King and Queen with texts, BURTON, *Excerpta Hiero.* vi [3]; CHAMPOLLION, *Not. Descr.* ii. 321 [3]; ROSELLINI, *Mon. Stor.* xxv [3 lower]; BURTON MSS.* 25634, 85, 89, 90 [3]; fragment of text in front of deceased, and concluding words of text, L. D. *Text*, ii, p. 130 [bottom right].

(4) Thickness, King with censer, Queen with bouquet, and three princesses, worship the Aten, with Queen's sister Mutbenret, dwarfs, and attendants below, and deceased with hymn at bottom, DAVIES, op. cit. ii, pls. viii, xxvii [left], cf. p. 30; NESTOR L'HÔTE MSS.* 20404, 35 [right]; upper scene, L. D. iii. 91 h; Princess 'Ankhesenpa-aten with sistrum, NESTOR L'HÔTE MSS.* 20410 (2), s (squeeze); name and title of same princess, L. D. iii. 91 p; concluding words of text at bottom, L. D. *Text*, ii, p. 130 [bottom left].

Outer Hall.

(5)-(6) Lintel, deceased kneeling at each end adores Aten-cartouches, jambs, burial petitions, DAVIES, op. cit. ii, pls. v [lower middle], ix [right, left], cf. p. 31; NESTOR L'HÔTE MSS.* 20404, 36 [right]; titles and cartouches, CHAMPOLLION, *Not. Descr.* ii. 321 [1]; ROSELLINI, *Mon. Stor.* xxv [3 upper]; BURTON, *Excerpta Hiero.* vi [1] (not quite accurate); id. MSS.* 25634, 94 [middle lower]; HAY*, 29847, 63 [top]; cartouches, name and title of deceased, and parts of texts of jambs, L. D. *Text*, ii, pp. 130 [middle], 131 [a and middle].

(7)-(8) Upper part, deceased rewarded before King, Queen, and four princesses, in palace, lower part, deceased acclaimed by household and escort, DAVIES, op. cit. ii, pls. x, xi [upper]; NESTOR L'HÔTE MSS.* 20404, 34; text of princesses behind balcony, L. D. iii. 91 o; four fan-bearers from top register, NESTOR L'HÔTE MSS.* 20410 (2), r (squeeze).

(9) Upper part, Royal family worship the Aten, and deceased and attendants with offerings, lower part, deceased received by escort, and waiting chariots, DAVIES, op. cit. ii,

pls. xii, xi [lower]; AMÉLINEAU, op. cit. in *Ann. Mus. Guimet*, xxix, pl. lxxxiii opposite p. 608 (from papers of NESTOR L'HÔTE); NESTOR L'HÔTE MSS.* 20404, 2; upper part, WILKINSON MSS.* ii. 45; head of courtier from top register, L. *D.* iii. 91 n; fan-bearers and servants, NESTOR L'HÔTE MSS.* 20410 (1), D, B (squeezes); name of Princess Neferneferu-aten, L. *D. Text*, ii, p. 131 [bottom right].

(10)-(11) Royal family and courtiers driving out from palace in chariots with military escort, DAVIES, op. cit. ii, pls. xiii-xvii; NESTOR L'HÔTE MSS.* 20404, 6, 28; King and Queen in chariots, id. 20410 (2), 2 (squeeze).

(12), (13) Royal visit to Aten-Temple, DAVIES, op. cit. ii, pls. xviii, xix, v [bottom right], cf. iv [h], p. 10; King worshipping, NESTOR L'HÔTE, *Lettres écrites d'Égypte*, 63; id. MSS.* 20404, 30; entrance to Temple with masts, id. *Lettres* [&c.], 64.

(14) King and Queen worship the Aten, and three courtiers below, DAVIES, op. cit. ii, pl. xx, cf. xxvi [lower]; NESTOR L'HÔTE MSS.* 20404, 31 [left].

Columns. Deceased kneeling before cartouches, from north and south columns, DAVIES, op. cit. ii, pl. iv [lower], cf. p. 30; one scene, NESTOR L'HÔTE MSS.* 20404, 31 [right].

Architraves. East architrave and three abaci, DAVIES, op. cit. ii, pls. iv [b-f], v [middle], xxvi [upper], cf. pp. 15-16; HAY*, 29847, 63 [middle upper]; architrave, BURTON MSS.* 25634, 104 verso [upper]; one abacus, L. *D. Text*, ii, p. 130 [top]. Text of west architrave, L. *D.* iii. 91 i.

Ceiling. Texts, DAVIES, op. cit. ii, pl. xxi [middle], cf. pp. 30-1.

Remains of frieze of south wall, id. ib. pl. v [bottom left].

Entrance to Inner Hall.

(15)-(16) Doorway, lintel, deceased at each end adores Aten-cartouches, jambs, burial petitions, id. ib. pl. xxi [top, right and left], cf. xxvi [upper], pp. 30, 31-2; jambs, NESTOR L'HÔTE MSS.* 20404, 31 [middle].

(17) Thickness, deceased and small daughter, DAVIES, op. cit. ii, pls. xxii, xxvii [middle]; AMÉLINEAU, op. cit. in *Ann. Mus. Guimet*, xxix, pl. xcix opposite p. 644 (from papers of NESTOR L'HÔTE); NESTOR L'HÔTE MSS.* 20404, 29 [right]; deceased, WILKINSON MSS.* ii. 45 verso [10].

Shrine.

(18) Deceased with family at table receives bouquet from servant, DAVIES, op. cit. ii, pl. xxiii; NESTOR L'HÔTE MSS.* 20404, 29 [left]; texts, HAY*, 29847, 63 [middle lower]; text above deceased and sister, L. *D. Text*, ii, p. 132 [near top]; names, and title of sister, L. *D.* iii. 91 k, m.

(19) Seated statue of deceased (removed); name, L. *D.* iii. 91 l, and *Text*, ii, p. 131 a; see DAVIES, op. cit. ii, p. 11.

South Group.

General plan, DAVIES, *The Rock Tombs of El Amarna*, iv, pl. xiii; BOURIANT, LEGRAIN and JÉQUIER, *Les Tombes de Khouitatonou* in *Mém. Inst. Fr. Arch. Or.* viii, pl. xiv.

7. PARENNUFER , Royal craftsman; Washer of hands of His Majesty.

Complete, DAVIES, op. cit. vi, pls. ii-x, and pp. 1-6; BOURIANT, &c., op. cit. pls. lxii-lxv, and pp. 123-7. Plan and sections, DAVIES, op. cit. vi, pl. ii [lower]; plan, BOURIANT, &c., op. cit. p. 125, fig. 47.

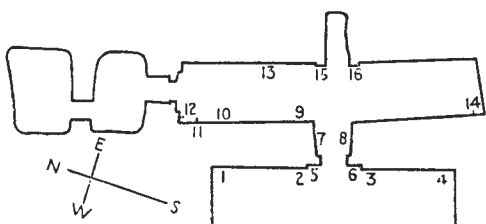

Tomb 7. Parennufer. From DAVIES, vi, pl. ii.

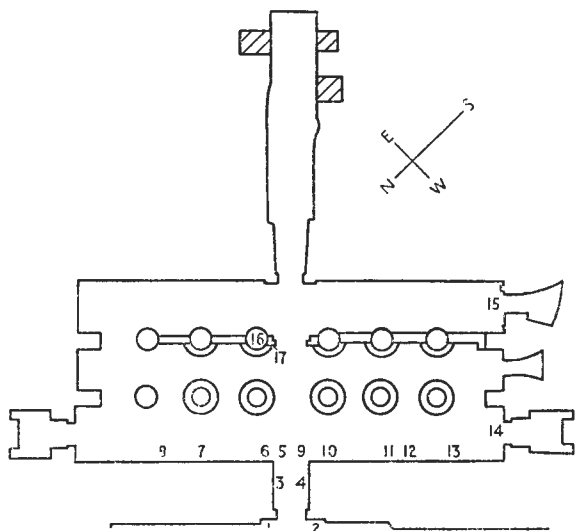

Tomb 8. Tutu. From DAVIES, vi, pl. xi.

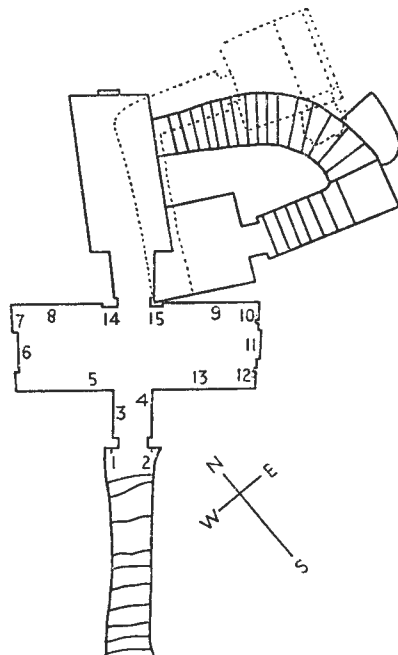

Tomb 9. Ma'hu. From DAVIES, iv, pl. xiv.

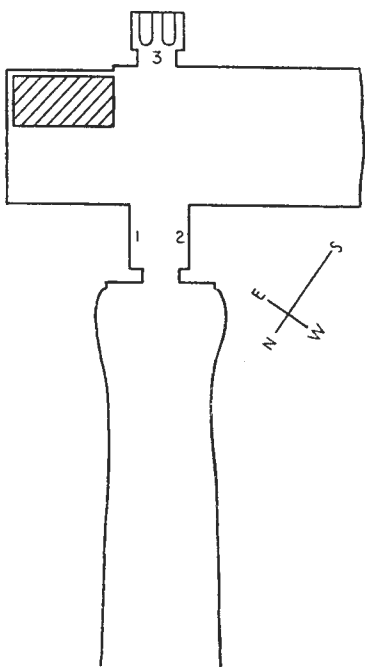

Tomb 11. Ra'mosi. From DAVIES, iv, pl. xxxiv [lower right].

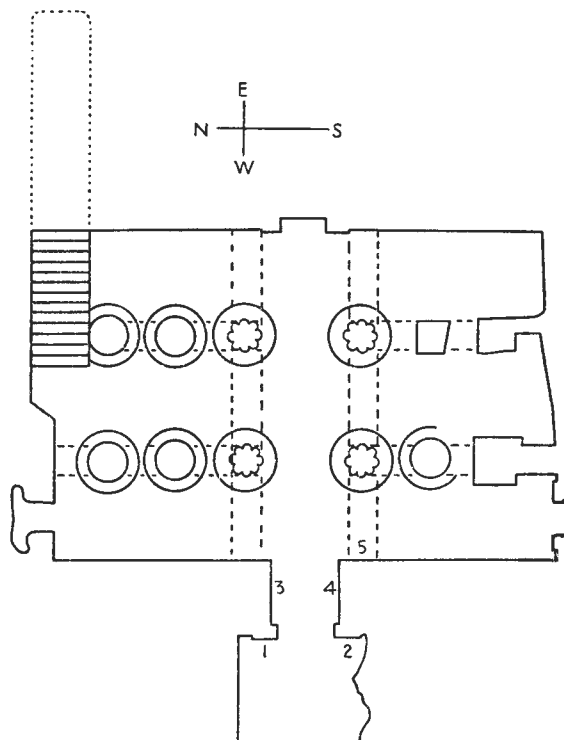

Tomb 14. Mey. From DAVIES, v, pl. i.

All these plans are from DAVIES, *The Rock Tombs of El Amarna*.

Façade.

(1)–(2) Royal family worship the Aten, with chariots and deceased kneeling in front of chapel below, DAVIES, *op. cit.* vi, pl. ii [upper left].

(3)–(4) Royal family worship the Aten, *id. ib.* pl. ii [upper right].

Entrance.

(5)–(6) Doorway. Lintel, Royal family worship the Aten, jambs, Aten-rays and cartouches, *id. ib.* pl. ii [upper middle].

(7) Thickness, Royal family, and attendants below, *id. ib.* pls. iii [right], vii [upper right], viii [left]; BOURIANT, &c., *op. cit.* pls. lxii, lxiii, *cf.* p. 123; omitting attendants, NESTOR L'HÔTE MSS.* 20396, 295 [bottom].

(8) Thickness, deceased adoring, DAVIES, *op. cit.* vi, pls. iii [left], viii [right], *cf.* p. 25; BOURIANT, &c., *op. cit.* pl. lxiv and p. 124; text, DARESSY, *Tombeaux et Stèles-limites de Hagi-Qandil* in *Rec. de Trav.* xv. 37; HAY*, 29814, 28, 29847, 16 [lower left]; NESTOR L'HÔTE MSS.* 20396, 295 [middle]; fragment of text, L. D. *Text*, ii, p. 147 [bottom].

Hall.

(9)–(10) Deceased rewarded before King and Queen in balcony of palace, with three princesses, and Mutbenret , sister of Nefertiti, and foreigners, courtiers, chariots, and servants bringing rewards, behind deceased, DAVIES, *op. cit.* vi, pls. iv, ix, x; BOURIANT, &c., *op. cit.* pl. lxv, and p. 126; L. D. iii. 108–9, *cf.* *Text*, ii, p. 148 [top]; HAY*, 29814, 39, 40; NESTOR L'HÔTE MSS.* 20411 (2), C–J (squeezes); King and Queen and courtiers, MASPERO, *Hist. Anc. des Peuples de l'Orient, Les Premières Mêlées*, *fig.* on p. 328; eldest princess behind King and Queen, DAVIES, *The Graphic Work of the Expedition* in *N.Y. Metro. Bull.* Pt. ii, Dec. 1923, p. 48, *fig.* 13 [right]; notable in front of King, and decoration of deceased, *id. ib.* p. 46, *fig.* 10; heads of foreigners, MEYER, *Darstellungen der Fremdvölker*, 70, 71; head of King, PETRIE, *Racial Types*, 610 (on sheet xiii); foreigners as decoration of balcony, DAVIES, *The Rock Tombs of El Amarna*, v, frontispiece; MEYER, *op. cit.* 72, 73; texts to scene, HAY*, 29847, 64 [bottom], 65 [top]; text above King and Queen, NESTOR L'HÔTE MSS.* 20396, 295 [top].

(11) Unfinished scene, deceased returns home with treasure, DAVIES, *op. cit.* vi, pl. v.

(12) Unfinished scene, remains of house and garden of deceased, *id. ib.* pl. vii [lower right].

(13) Unfinished scene, musicians, food, &c., and two courtiers before King in kiosk, *id. ib.* pl. vi.

(14) Remains of hieratic graffiti, *id. ib.* pl. vii [upper left].

Entrance to Shrine.

(15) and (16) Jambs; titles of deceased, *id. ib.* pl. vii [lower left].

8. TUTU , Chamberlain (?); &c.

DAVIES, *The Rock Tombs of El Amarna*, vi, pls. xii–xxi, xxxv, xxxvi [upper], and pp. 7–15; BOURIANT, LEGRAIN and JÉQUIER, *op. cit.* in *Mém. Inst. Fr. Arch. Or.* viii, pls. lii–lxi, pp. 107–21. Plan and sections, DAVIES, *op. cit.* vi, pls. xi, xii [left], xiii [left]; L. D. *Text*, ii, p. 145 [bottom]; HAY*, 29847, 49 verso [upper], 50; plan, BOURIANT, &c., *op. cit.* p. 107, *fig.* 45; sketch-plans, NESTOR L'HÔTE MSS.* 20396, 298; LEPSIUS MSS.* *Diary*, pages at end, 62. Views, DAVIES, *op. cit.* vi, pls. xxxv [right], xxxvi [upper]; BOURIANT, &c., *op. cit.* pl. lv; MASPERO, *op. cit.* *fig.* on p. 331; EVERS, *Staat aus dem Stein*, i, p. 57, *Abb.* 13.

Façade.

(1)-(2) Doorway. Lintel, and jambs, MARIETTE, *Voyage*, pl. 18; MASPERO, op. cit. fig. on p. 329; BOURIANT, &c., op. cit. pl. lii, and pp. 108-9; jambs, with deceased kneeling at bottom on one side, DAVIES, op. cit. vi, pls. xv [left], xiii [right], cf. xxxiv [middle right], and p. 31; parts of four columns of text on north jamb, L. D. *Text*, ii, p. 146 [upper right]; ends of columns of text on south jamb, L. D. iii. 107 c.

Entrance.

(3) Thickness, Royal family worship the Aten, and deceased kneeling with hymn below, DAVIES, op. cit. vi, pls. xvi, xxxv [left]; BOURIANT, &c., op. cit. pl. liv, and pp. 112-13; L. D. iii. 106 b; HAY*, 29814, 37, 29847, 15, 16 [upper]; NESTOR L'HÔTE MSS.* 20404, 37, 20411, A, B (squeezes); lower part, text behind deceased, L. D. *Text*, ii, p. 146 [right lower].

(4) Thickness (nearly destroyed), deceased kneeling and hymn to the Aten, DAVIES, op. cit. vi, pl. xv [right], cf. pp. 25-7; BOURIANT, &c., op. cit. pl. liii and pp. 109-12; L. D. iii. 107 a, cf. *Text*, ii, p. 146 [left]; HAY*, 29814, 12, 29847, 14; parts of hymn, see BREASTED, *De Hymnis in Solem*, 34, 36, 39.

Ceiling. Texts, DAVIES, op. cit. vi, pl. xiv [middle], cf. p. 32.

Pillared Hall.

(5)-(7) Upper part, deceased before King and Queen (destroyed) seated in door of palace, with officials and spectators behind deceased, id. ib. vi, pls. xvii, xviii [left]; BOURIANT, &c., op. cit. pl. lx and p. 120; King and Queen, L. D. iii. 107 b; sketch of scene, NESTOR L'HÔTE MSS.* 20396, 297 [lower].

(6)-(7) Lower part, prayer and deceased, BOURIANT, &c., op. cit. pl. lix and p. 119; hymn, DAVIES, op. cit. vi, pl. xix [right], cf. p. 27.

(8) Upper part, deceased with officials, servants, &c., outside palace, id. ib. pl. xviii [right]; BOURIANT, &c., op. cit. pl. lxi and p. 121.

(9)-(11) Upper part, deceased rewarded before King and Queen in balcony of palace, and foreigners, officials, and servants behind deceased, with waiting chariots below, DAVIES, op. cit. vi, pls. xix [left], xx [right]; BOURIANT, &c., op. cit. pl. lvii and pp. 117-18; sketch of scene, NESTOR L'HÔTE MSS.* 20404, 84.

(10)-(11) Lower part, deceased and prayer, BOURIANT, &c., op. cit. pl. liv and pp. 114-17; prayer, DAVIES, op. cit. vi, pl. xxi, cf. pp. 27-8.

(12)-(13) Upper part, deceased escorted home by friends, id. ib. pl. xx [middle and left]; omitting house, BOURIANT, &c., op. cit. pl. lviii.

(14) and (15) Entablatures, deceased kneeling at each end adores Aten-cartouches, DAVIES, op. cit. vi, pl. xii [bottom left]; HAY*, 29847, 49 verso [lower].

(16)-(17) Column with jamb on which are scenes of Royal family worshipping the Aten, and deceased kneeling below, DAVIES, op. cit. vi, pl. xiv [left], cf. pp. 31-2; HAY*, 29847, 44 [left and middle]; NESTOR L'HÔTE MSS.* 20396, 298 verso; omitting scenes on jamb, L. D. iii. 106 c.

Architraves. Text, DAVIES, op. cit. vi, pl. xiv [right], cf. p. 32.

Ceiling. Texts, id. ib. pl. xii [right], cf. p. 32.

9. MA'ĤU , Commandant of police of Akhetaten.

Complete, DAVIES, *The Rock Tombs of El Amarna*, iv, pls. xii [A-C], xv-xxix, xl-xlii, pp. 12-18; BOURIANT, LEGRAIN and JÉQUIER, op. cit. in *Mém. Inst. Fr. Arch. Or.* viii, pls. xli-li, and pp. 93-105. Plan and sections, DAVIES, op. cit. iv, pl. xiv; plan, BOURIANT, &c., op. cit. p. 93, fig. 39; BOURIANT, *Deux jours de fouilles à Tell el Amarna* in *Mém. Miss. Arch. Fr.* i, p. 16 (inaccurate).

Façade.

(1)-(2) Doorway. Jambs, burial petition, DAVIES, op. cit. iv, pl. xxviii [right and left], cf. pp. 30-1; BOURIANT, &c., op. cit. pp. 94-5 with figs. 40, 41.

Entrance.

(3) Thickness, upper part, King, Queen, and Princess Merytaten sacrificing at the altar of the Aten, lower part, deceased kneeling and hymn to the Aten, DAVIES, op. cit. iv, pls. xv, xxix [bottom], xl [left], cf. pp. 28-9; BOURIANT, &c., op. cit. pl. xli, and pp. 95-7 with fig. 42.

(4) Thickness, deceased and hymn, id. ib. p. 97, fig. 43; hymn, BOURIANT, op. cit. in *Mém. Miss. Arch. Fr.* i, p. 17; figure of deceased, DAVIES, op. cit. iv, pl. xxix [upper left].

Outer Hall.

(5) Upper part, destroyed scene of deceased rewarded before King; sketch (unfinished) of King in balcony, id. ib. iv, pl. xxix [top right].

(6) Stela, King and Queen before altar, and deceased kneeling below, id. ib. pl. xvi, cf. xlii [lower right], xxix [middle right]; BOURIANT, &c., op. cit. pl. xlii, cf. p. 98.

(7)-(8) Lower part (unfinished), deceased and his troops before Temple, DAVIES, op. cit. iv, pls. xix, xviii, xlii [top, and bottom left]; BOURIANT, &c., op. cit. pls. xliii [lower], xliv, and p. 99; small boy clapping troops, id. ib. p. 99, fig. 44.

(8) Upper part, chariots, attendants, and deceased receiving standard before palace, DAVIES, op. cit. iv, pl. xvii; BOURIANT, &c., op. cit. pl. xliii [upper], and pp. 98-9.

(9)-(10) and (11 top left) Upper part, King and Queen in chariot preceded by vizier and police leave Temple to inspect block-house, DAVIES, op. cit. iv, pls. xii [c], xx, xxi [upper, and lower left], cf. xxviii [middle]; BOURIANT, &c., op. cit. pl. xlv, cf. p. 100. Lower part at (9)-(10), King and Queen with Princess Merytaten in chariot passing sentries, DAVIES, op. cit. iv, pls. xii [A], xxii, xxi [lower right], xl [right], xli [lower]; BOURIANT, &c., op. cit. pls. xlvi, xlvii, xlviii [left], and p. 101 [bottom].

(11) Stela, King and Queen before altar, and deceased kneeling below, DAVIES, op. cit. iv, pl. xxiii, cf. xxviii [middle]; BOURIANT, &c., op. cit. pl. xlviii [middle] and p. 102.

(11 top right) and (12)-(13). Upper part, two registers, deceased superintending the provisioning of the guard-houses, DAVIES, op. cit. iv, pls. xxiv-xxv [upper, lower right], cf. xxviii [middle]; BOURIANT, &c., op. cit. pls. xlviii [top and right], xlix, cf. p. 103. Lower part at (12)-(13), two registers, deceased brings prisoners to vizier, DAVIES, op. cit. iv, pls. xii [B], xxv [lower left], xxvi, xli [upper]; BOURIANT, &c., op. cit. pl. l, cf. pp. 103-4.

Entrance to Inner Hall.

(14)-(15) Doorway. Lintel, deceased at each end adores Aten-cartouches, jambs, hymn to the Aten with deceased kneeling at bottom, DAVIES, op. cit. iv, pl. xxvii; BOURIANT, &c., op. cit. pl. li, and pp. 104-5.

10. IPY , Royal scribe; Steward.

DAVIES, *The Rock Tombs of El Amarna*, iv, pls. xxxi-xxxiii, xxxix [left], xliii-xliv, cf. pp. 19-20; BOURIANT, LEGRAIN and JÉQUIER, op. cit. in *Mém. Inst. Fr. Arch. Or.* viii, pls. xxxviii-xl and pp. 87-92. Plan and section, DAVIES, op. cit. iv, pl. xxx [right lower]; plan, BOURIANT, &c., op. cit. p. 87, fig. 37.

Façade.

Doorway. West (right) jamb, burial petition, DAVIES, op. cit. iv, pl. xxxix [left], cf. p. 31. East (left) jamb, burial petition, BOURIANT, &c., op. cit. pl. xxxviii [a] and p. 87.

Entrance.

West (right) thickness. Hymn to the Aten, DAVIES, op. cit. iv, pl. xliii [bottom left], cf. xxxii, xxxiii, and pp. 28-9; BOURIANT, &c., op. cit. pl. xxxviii [b], and pp. 88-9; BOURIANT, op. cit. in *Mém. Miss. Arch. Fr.* i, pp. 11-12; PIEHL, *Inscr. Hiéro.* i Sér. cxci-cxcii a; part, see BREASTED, *De Hymnis in Solem*, 27.

East (left) thickness. Upper part, King, Queen, and Princesses Merytaten, Meke-taten, and 'Ankhesenpa-aten, offer votive pieces to the Aten, DAVIES, op. cit. iv, pls. xxxi, xlv; BOURIANT, &c., op. cit. in *Mém. Inst. Fr. Arch. Or.* viii, pls. xxxix, xl, and pp. 89-90; JÉQUIER, *Hist. de la Civilisation Ég.* p. 236, fig. 200; text of Queen, and names of princesses, BOURIANT, op. cit. in *Mém. Miss. Arch. Fr.* i, pp. 13-14 [top]. Lower part, deceased with prayer, BOURIANT, &c., op. cit. in *Mém. Inst. Fr. Arch. Or.* viii, pp. 90-1 with fig. 38; prayer, BOURIANT, op. cit. in *Mém. Miss. Arch. Fr.* i, pp. 14-15.

Ceiling. Burial petition, DAVIES, op. cit. iv, pl. xxxii [left], cf. p. 31; PIEHL, op. cit. cxcii β; BOURIANT, &c., op. cit. in *Mém. Inst. Fr. Arch. Or.* viii, p. 92; BOURIANT, op. cit. in *Mém. Miss. Arch. Fr.* i, p. 15 [middle].

II. RA'MOSI , Royal scribe; Commander of troops of the Lord of the Two Lands; Steward of Nebma'etrē'. (See plan, supra p. 220.)

DAVIES, op. cit. iv, pls. xi [right], xxv, xlv, cf. pp. 21-2 BOURIANT, &c., op. cit. pl. xxxvii and pp. 83-5. Plan and section, DAVIES, op. cit. iv, pl. xxxiv [lower right]; plan, BOURIANT, &c., op. cit. p. 83, fig. 35.

Entrance to Hall.

(1) Thickness, King, Queen, and Princess Merytaten worship the Aten, DAVIES, op. cit. iv, pls. xi [right], xxxv [left]; BOURIANT, &c., op. cit. p. 84, fig. 36.

(2) Thickness, deceased and prayer, DAVIES, op. cit. iv, pls. xxxv [right], xlv [left], cf. p. 30; BOURIANT, &c., op. cit. pl. xxxvii, pp. 83-4; incomplete text, BOURIANT, op. cit. in *Mém. Miss. Arch. Fr.* i, pp. 9-10.

Hall.

(3) Recess. Statues of deceased and wife, DAVIES, op. cit. iv, pl. xlv [right]; text, id. ib. p. 21; BOURIANT, &c., op. cit. in *Mém. Inst. Fr. Arch. Or.* viii, p. 85.

12. NEKHT-PA-ATEN , Hereditary prince; Chancellor; Vizier.

See DAVIES, op. cit. v, pp. 12-13. Plan, id. ib. pl. xiv [top middle]; BOURIANT, &c., op. cit. p. 81, fig. 34.

Entrance.

Fragments of text (destroyed) on jambs, id. ib. p. 81; DARESSY, *Tombeaux et Stèles-limites de Hagi-Qandil* in *Rec. de Trav.* xv. 38 [top]; see DAVIES, op. cit. v, p. 12.

13. NEFERKHEPRU-HER-SEKHEPER , Mayor of Akhetaten.

See DAVIES, op. cit. iv, pl. xxxvi, pp. 23-4. Plan and sections, id. ib. pl. xxxvii [right]; HAY*, 29847, 43. Views, DAVIES, op. cit. iv, pl. xliii [upper, lower right], pp. 23-4; BOURIANT, &c., op. cit. pl. xxxvi; WRESZINSKI, *Bericht über die photographische Expedition* [&c.], pl. 19 [A].

Façade.

Doorway. Jambs, burial petition, DAVIES, op. cit. iv, pl. xxxvii [left], cf. p. 31; texts, BOURIANT, &c., op. cit. p. 79; DARESSY, op. cit. 38 [middle].

14. MEY , Fan-bearer on the right of the King; Steward of the house of Sehetep-Aten and of the house of Wa'enrē in On; Overseer of cattle of the Estate of Rē' in On; &c. ('Tombeau du Flabellifère.') (See plan, supra p. 220.)

DAVIES, *The Rock Tombs of El Amarna*, v, pls. ii-v, xix [lower], xxxv [right], xxxvi [top left], pp. 1-5; BOURIANT, LEGRAIN and JÉQUIER, op. cit. in *Mém. Inst. Fr. Arch. Or.* viii, pls. xxxi-xxxv, and pp. 71-7; see BOURIANT, op. cit. in *Mém. Miss. Arch. Fr.* i, p. 8. Plan and sections, DAVIES, op. cit. v, pls. i, ii [upper]; plan, BOURIANT, &c., op. cit. in *Mém. Inst. Fr. Arch. Or.* viii, p. 71, fig. 32.

Façade.

(1)-(2) North end of lintel, with remains of scene with three princesses, and Mutbenret , sister of Nefertiti, DAVIES, op. cit. v, pl. v [upper]. Jambs, burial petition, id. ib. pl. iv [right and left], cf. pp. 17-18; BOURIANT, &c., op. cit. pl. xxxi, and pp. 72-3; DARESSY, op. cit. in *Rec. de Trav.* xv. 41.

Entrance.

(3) Thickness, upper part, Royal family worship the Aten, lower part, hymn to the Aten, and deceased (destroyed), DAVIES, op. cit. v, pls. iii, xxxvi [top left], ii [bottom left], xix [lower], cf. p. 16; BOURIANT, &c., op. cit. pls. xxxii, xxxiii, and pp. 73-5; lower part, DARESSY, op. cit. 38-9.

(4) Thickness, hymn to the Aten, and deceased (erased), BOURIANT, &c., op. cit. pl. xxxiv, and pp. 75-6; texts, DAVIES, op. cit. v, pl. iv [middle]. cf. p. 4.

Ceiling. Remains of texts, id. ib. pl. ii [bottom right], cf. p. 18; middle part, BOURIANT, &c., op. cit. p. 76; DARESSY, op. cit. 40-1.

Hall.

View, DAVIES, op. cit. v, pl. xxxv [right].

(5) Unfinished scene, deceased rewarded at palace, with royal gardens and barges in foreground, id. ib. pl. v [lower]; gardens and barges, BOURIANT, &c., op. cit. pl. xxxv; text of deceased (?), id. ib. p. 77.

Graffiti on north part of west wall, DAVIES, op. cit. v, pl. v [left], cf. p. 4; BOURIANT, &c., op. cit. p. 77, fig. 33.

15. SUTI , Standard-bearer of the Guild of Neferkheprurē'.

See DAVIES, op. cit. iv, p. 25. Plan and sections, id. ib. pl. xxxviii; plan, BOURIANT, &c., op. cit. p. 67, fig. 29.

Façade.

Jambs, burial petition, DAVIES, op. cit. iv, pl. xxxix [middle and right], cf. p. 31; BOURIANT, &c., op. cit. pp. 67-9 with figs. 30, 31; DARESSY, op. cit. 42.

18. NAME DESTROYED.

See DAVIES, op. cit. v, p. 14. Plan and section, id. ib. pl. xiii.

Entrance.

Remains of hymn to the Aten on north-east (left) jamb, id. ib. pl. xiii [bottom left], cf. p. 18; text, BOURIANT, &c., op. cit. p. 129; BOURIANT, *Rapport . . . sur une Mission dans la Haute Égypte (1884-1885)* in *Mém. Miss. Arch. Fr.* i. 368.



Tomb 23. Any. From DAVIES, *The Rock Tombs of El Amarna*, v, pl. viii.

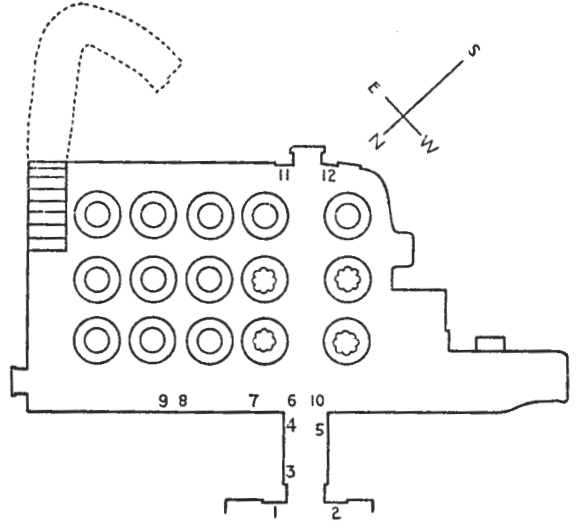

Tomb 25. Ay. From DAVIES, *The Rock Tombs of El Amarna*, vi, pl. xxii.

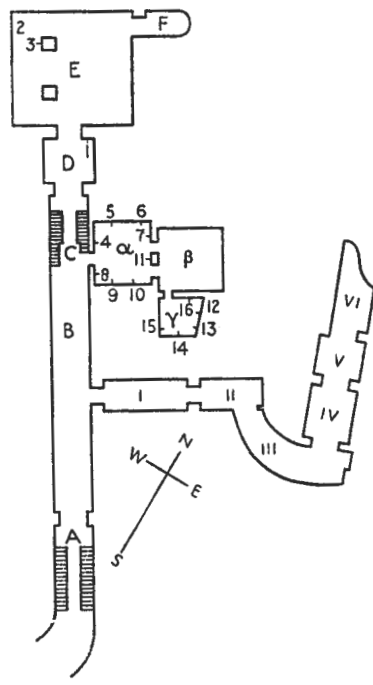

EL 'AMARNA. ROYAL TOMB.

After BOURIANT, LEGRAIN, and JÉQUIER, in *Mém. Inst. Fr. Arch. Or.* viii, p. 5, fig. 1.

19. SUTAU , Overseer of the Treasury of the Lord of the Two Lands.

See DAVIES, op. cit. v, p. 14. Plan and section, id. ib. pl. xiv [lower right]; plan, BOURIANT, &c., op. cit. in *Mém. Inst. Fr. Arch. Or.* viii, p. 63, fig. 27.

Entrance.

North thickness, remains of prayer and deceased kneeling, DAVIES, op. cit. v, pl. xv [lower], cf. p. 17; BOURIANT, &c., op. cit. pl. xxx.

20. NAME UNKNOWN.

See DAVIES, op. cit. v, p. 14. Plan and section, id. ib. pl. xii [left]; plan, BOURIANT, &c., op. cit. p. 61, fig. 25.

Façade.

Lintel, unfinished double scene of Royal family (including Mutbenret) worshipping the Aten, DAVIES, op. cit. v, pl. xv [upper].

22. NAME UNKNOWN.

See id. ib. p. 14. Plan and sections, id. ib. pl. xvii; plan, BOURIANT, &c., op. cit. p. 57, fig. 22. View, DAVIES, op. cit. v, pl. xxxvi [lower left].







Façade.

Lintel, remains of scene of Royal family worshipping, id. ib. pl. xvi [top left].

23. ANY , Royal scribe; Scribe of the offering-table of the Aten; Steward of the Temple of 'Akheprurē', &c.

DAVIES, op. cit. v, pls. ix-xi, xx-xxiii, pp. 6-11; BOURIANT, LEGRAIN, and JÉQUIER, op. cit. in *Mém. Inst. Fr. Arch. Or.* viii, pls. xxv-xxix, pp. 49-56. Plan and sections, DAVIES, op. cit. v, pl. viii; plan, BOURIANT, &c., op. cit. p. 50, fig. 18.

Vestibule.

(1) Six stelae, Nebwawi , Scribe, Thay , Charioteer, Any-men , Servant, [Ptah]mey , brother of Any, Pakha , Overseer of works, and Ay , Servant, (four found *in situ* on west wall), in Cairo Mus. 34176-34181, LACAU, *Stèles du Nouvel Empire* (Cat. Caire), pls. lxvi-lxviii, pp. 217-22; DAVIES, op. cit. v, pls. xxi-xxiii, cf. pp. 9-11; omitting Ay, DARESSY, op. cit. in *Rec. de Trav.* xv. 44 [bottom]-45 [upper]; omitting Ptahmey and Ay, STEINDORFF, *Vier Grabstelen aus der Zeit Amenophis' iv* in *Ä.Z.* xxxiv, pp. 63-7, with Abb. i-iv; BOURIANT, &c., op. cit. pls. xxv, xxvi, pp. 49-51; names from the six stelae, LEGRAIN, *Répertoire*, Nos. 303-8.

Façade.

(2)-(3) Lintel, double scene, Royal family worship the Aten, jambs, royal and Aten cartouches, and deceased with hymn at bottom; jambs, DAVIES, op. cit. v, pl. xi [left and right], cf. p. 17; BOURIANT, &c., op. cit. pl. xxvii, pp. 51-2; texts, DARESSY, op. cit. 44 [middle].

Entrance.

(4) Thickness, deceased adores the Aten (unfinished), BOURIANT, &c., op. cit. pl. xxviii, pp. 52-3; hymn, DARESSY, op. cit. 43-4 [top]; end of hymn, DAVIES, op. cit. v, p. 7, cf. pls. xxxii, xxxiii.

(5) Thickness, deceased entering (unfinished), id. ib. pl. xx [left]; BOURIANT, &c., op. cit. pl. xxix.



(6) Sketch of deceased near top, DAVIES, op. cit. v, pl. xi [middle]; BOURIANT, &c., op. cit. p. 54, fig. 19.

Shrine.

View showing statue, DAVIES, op. cit. v, pl. xx [right].

(7) Deceased seated before offering-table with servant reciting formula (unfinished), id. ib. pl. ix, cf. p. 17; BOURIANT, &c., op. cit. p. 55, fig. 20.

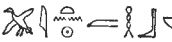
(8) Deceased and wife with servant offering ointment (unfinished), DAVIES, op. cit. v, pl. x, cf. pp. 8, 17; BOURIANT, &c., op. cit. p. 56, fig. 21.

24. PA-ATEN-EM-HAB  = , Royal scribe; Commander of troops, and Steward, of the Lord of the Two Lands; Overseer of works in Akhetaten.

See DAVIES, *The Rock Tombs of El Amarna*, v, p. 15. Plan and section, id. ib. pl. xiii [top right]; plan, BOURIANT, LEGRAIN, and JÉQUIER, op. cit. in *Mém. Inst. Fr. Arch. Or.* viii, p. 47, fig. 17.

Façade.

Jambs (destroyed) with titles of deceased; texts, DARESSY, op. cit. in *Rec. de Trav.* xv. 45 [middle lower]; of north jamb, DAVIES, op. cit. v, pl. xiii [top left]; BOURIANT, &c., op. cit. p. 47.

25. AY , Divine father; Fan-bearer on the right of the King; Overseer of all the horses of His Majesty; &c. (Afterwards King.)

DAVIES, op. cit. vi, pls. xxiii-xxxiii, xxxvi [lower]-xliv, pp. 16-24; BOURIANT, &c., op. cit. pls. xv-xxiv, and pp. 25-46. Plan and sections, DAVIES, op. cit. vi, pls. xxii, xxiii [upper]; HAY*, 29847, 42 [left]; plan, BOURIANT, &c., op. cit. p. 26, fig. 10. View of interior, DAVIES, op. cit. vi, pl. xxxvii; TIMME, *Tell el-Amarna*, p. 28, Abb. 28; WRZESINSKI, *Bericht über die photographische Expedition* [&c.], pl. 18 [B].

Façade.

(1)-(2) Lintel, effaced scene of Royal family offering to the Aten, jambs, prayers and deceased with wife Teye , Nurse of the Great Royal Wife Nefertiti, Governess of the Queen, Royal ornament, kneeling below; jambs, BOURIANT, &c., op. cit. pl. xv, pp. 28-9; texts of jambs, and head of deceased, DAVIES, op. cit. vi, pls. xxiv, xxxi [top right], cf. pp. 32-3.

Entrance.

(3)-(4) Thickness, King and Queen followed by three princesses, and Mutbenret , Queen's sister, with two female dwarfs and courtiers, worship the Aten, and deceased and wife Teye with prayer below, id. ib. pls. xxv [upper], xxvi [upper], xxxi [middle], xxxviii [lower], xxxix, xl, cf. pp. 28-9; BOURIANT, &c., op. cit. pls. xviii-xx, pp. 34-7; deceased and wife kneeling, JÉQUIER, *Hist. de la Civilisation Ég.* p. 279, fig. 242; texts of upper part, HAY*, 29847, 65 [left]; text (destroyed) above Queen, L. D. *Text*, ii, p. 142; texts of lower part, DARESSY, op. cit. in *Rec. de Trav.* xv. 46-8, 49 [bottom].

(5) Thickness, deceased and wife Teye and hymn to the Aten, DAVIES, op. cit. vi, pls. xxvii, xli, and frontispiece, cf. pp. 29-31; BOURIANT, &c., op. cit. pls. xvi, xvii, pp. 30-3; hymn, BOURIANT, op. cit. in *Mém. Miss. Arch. Fr.* i, pp. 2-5; names and titles, DARESSY, op. cit. 45 [bottom].

Ceiling. Texts, DAVIES, op. cit. vi, pl. xxv [lower], cf. p. 34; BOURIANT, &c., op. cit. in *Mém. Inst. Fr. Arch. Or.* viii, pl. xxii [1], p. 37.

Hall.

(6)–(8) Upper part, deceased with wife Teye, followed by four registers officials, foreigners, soldiers, and dancers, rewarded by King with Queen and three princesses in balcony of palace, and behind them Mutbenret with dwarfs, palace-storehouses, and harîm with foreign women, DAVIES, op. cit. vi, pls. xxviii [top and right], xxix, xxxvi [lower], xlii, xliii, cf. xxvi [lower]; L. D. iii. 106 a, 103, 104, 111, cf. 295 [46, 47]; HAY*, 29814, 58 [right], 41 [left]; omitting palace, BOURIANT, &c., op. cit. pl. xxiii, pp. 41–2; texts of whole scene, HAY*, 29847, 67; Royal family in balcony, WILKINSON, *M. and C.* ed. Birch, i, pl. iii opposite p. 40; STEINDORFF, *Die Blütezeit des Pharaonenreichs* (1900), p. 156, Abb. 131; id. *Die Kunst der Ägypter*, p. 239; WRESZINSKI, *Atlas*, ii. 133 [right]; NESTOR L'HÔTE MSS.* 20404, 13; King in balcony, VILLIERS STUART, *The Funeral Tent of an Egyptian Queen*, pl. 18 opposite p. 97; Queen and princesses, id. *Nile Gleanings*, pl. 54 opposite p. 72; part of palace, BOURIANT, &c., op. cit. p. 45, fig. 15; part of scenes inside palace, and back of balcony, L. D. *Text*, ii, p. 144; harîm (above door), PRISSE, *L'Art Égyptien*, i, *Architecture*, pl. 39 [upper] 'Plans cavaliers des édifices de Tell el-Amarna', cf. *Texte*, pp. 372–3; name of one dwarf attending on Mutbenret, L. D. *Text*, ii, p. 143 [upper right]; two groups of soldiers from fourth register behind deceased, WRESZINSKI, *Atlas*, ii. 14; one group, MEYER, *Darstellungen der Fremdvölker*, 78; SCHÄFER and ANDRAE, *Die Kunst des alten Orients*, 363 [2]; boys dancing from fifth register, DAVIES, *The Graphic Work of the Expedition in N. Y. Metro. Bull.* Pt. ii, Feb. 1928, p. 60, fig. 2; three of the boys, BOURIANT, &c., op. cit. p. 43, fig. 14; upper parts of deceased and wife Teye in front of balcony, in Cairo Mus., DAVIES, *The Rock Tombs of El Amarna*, vi, pl. xxxviii [upper]; BOURIANT, &c., op. cit. p. 42, fig. 13; DAVIES, *The Graphic Work of the Expedition in N. Y. Metro. Bull.* Pt. ii, Dec. 1923, p. 50, fig. 17; see MEYER, op. cit. 31 [upper].

(9) At top, deceased wearing decorations received by friends and escort outside Temple, with sentry-posts at gate above, DAVIES, *The Rock Tombs of El Amarna*, vi, pls. xxx, xxxi [top left], xlv; L. D. iii. 105 a; BOURIANT, &c., op. cit. pl. xxiv, pp. 44–5; HAY*, 29814, 41 [right]; group with deceased wearing decorations, HAY*, 29850, 269–70 (tracings).

(10) Above doorway, unfinished scene of palace, DAVIES, op. cit. vi, pl. xxviii [lower left]; HAY*, 29814, 58 [left].

(11)–(12) Inner doorway. Lintel (centre destroyed), deceased and wife Teye kneeling at each end adore Aten-rays and cartouches, DAVIES, op. cit. vi, pl. xxxi [lower], cf. p. 33; L. D. iii. 105 f; BOURIANT, &c., op. cit. p. 46 with fig. 16; sketch, HAY*, 29814, 13; texts, HAY*, 29847, 66 [left]; left half, NESTOR L'HÔTE MSS.* 20404, 38. Jambs, five columns text (mostly destroyed), and deceased and wife Teye kneeling at bottom on each side; texts, DAVIES, op. cit. vi, pl. xxxii [left and middle], xxxi [middle right], cf. xxxiv [right], pp. 33–4; HAY*, 29847, 66 [right]; east jamb, L. D. iii. 107 d (incorrectly called Parenufer, cf. *Text*, ii, p. 145 note 2); titles of deceased from middle column of text on west jamb, L. D. *Text*, ii, p. 145 a; deceased and wife Teye kneeling, from west jamb, DAVIES, op. cit. vi, pl. xxxi [middle right], cf. p. 23.

Columns.

Architraves; text of east one, id. ib. pl. xxxii [right], cf. p. 34 with note 4; L. D. iii. 105 b, c and *Text*, ii, p. 143 [near bottom]; BOURIANT, &c., op. cit. p. 40 [lower]; NESTOR L'HÔTE MSS.* 20396, 297 [upper].

Abaci. North pair, east and west of central aisle, L. *D.* iii. 105 d, e; HAY*, 29847, 42 [right], 65 [right]; part, DAVIES, op. cit. vi, pls. xxxi [top middle], xxxiv [bottom middle]; titles of deceased below cartouches, L. *D. Text*, ii, pp. 143 [bottom], 145 [top]; part, BOURIANT, &c., op. cit. p. 41 [top].

Small scenes on shafts, deceased and wife Teye adoring, id. ib. p. 41, figs. 11, 12, cf. pl. xxi; see DAVIES, op. cit. vi, pls. xxiii [bottom right], xxxvii.

Ceiling. Texts, id. ib. pl. xxxiii, cf. pp. 34-5; BOURIANT, &c., op. cit. pl. xxii [2-4], pp. 39-40. Decoration, DAVIES, op. cit. vi, pl. xxiii [bottom left].

25 A. IY (?) (?)

Plan and section, id. ib. v, pl. xiv [left].

Entrance.

Remains of hymn to the Aten on right jamb, id. ib. p. 15.

BOUNDARY STELAE ¹

PETRIE, *Tell el Amarna*, pp. 5-6; DAVIES, *The Rock Tombs of El Amarna*, v, pp. 19-34. Collation of texts, id. ib. pls. xxvii, xxviii. Plan showing positions, PETRIE, op. cit. pls. xxxiv, xxxv; DAVIES, op. cit. pl. xxxiv [upper].

West Bank (Tûna el-Gebel).

STELA A. Year 6.

Amenophis IV, Nefertiti, and Princesses Merytaten and Meketaten adore the Aten, with twenty-five lines text below, and on south side two groups of statues of King, Queen, and princesses holding tablets before them, with princesses in relief on sides ('Ankhesenpaten added on one side of north tablet). Views, DAVIES, op. cit. v, pls. xli [lower], xliii (from HAY), cf. xxxiv [bottom right], pp. 23-4; TIMME, *Tell el-Amarna*, p. 56, Abb. 60; HAY*, 29814, 32-4. Description, BONOMI MSS.* Diary, Jan. 16, 1825; SAINT-FERRIOL MSS.* Diary, May 12, 1842. Scene and text, PRISSE, *Mon.* xiv; text, DARESSY, *Tombeaux et Stèles-limites de Hagi-Qandil* in *Rec. de Trav.* xv. 61-2 [8°]; vertical text, and last six lines of horizontal text, DAVIES, op. cit. v, pl. xxxiii [upper left and lower]; omitting middle part, NESTOR L'HÔTE MSS.* 20396, 304; scene, date of year 6, and Horus-name from upper part, id. *Lettres écrites d'Égypte*, 59, 131. Statues of Queen Nefertiti and two princesses, from inner group, DAVIES, op. cit. v, pls. xxxiv [bottom left], xxxvi [bottom right]; NESTOR L'HÔTE MSS.* 20396, 305, 306.

STELA B. Year 6.

King, Queen, and two princesses adore the Aten, with twenty-seven lines text below. View, L. *D.* i. 61 [lower]. Texts, L. *D.* iii. 91 a-f, and *Text*, ii, p. 114; last six lines, DAVIES, op. cit. v, pl. xxxiii [lower], cf. p. 24.

STELA F. Year 6.

Upper part destroyed, fourteen lines text below, see PETRIE, op. cit. p. 5; DAVIES, op. cit. v, p. 24.

East Bank (north to south).

STELA X. Year 4.

Destroyed scene of King, Queen, and Princess Merytaten (?), adoring, and text below; text, id. ib. pls. xxxi-xxxii, cf. p. 27.

¹ The lettering of the stelae is that used by PETRIE and DAVIES.

STELA V. Year 6. (Destroyed.)

See id. ib. p. 27.

STELA U. Year 6.

King, Queen, and two princesses adore the Aten, and twenty-four lines text below, with statue-group on north side, and statues with tablets south of Royal family. View and text, id. ib. pls. xxv, xxxvii [left], cf. p. 27; stela, PRISSE, *Mon.* xii; sketch, NESTOR L'HÔTE MSS.* 20396, 302.

STELA S. Year 6.

Double scene, King, Queen, and two princesses worship the Aten with twenty-six lines text below, and statue-groups holding tablets on either side. Views, DAVIES, op. cit. v, pl. xl [upper], cf. xlv [bottom middle]. Stela, id. ib. pls. xxvi, xxxix, cf. pp. 26-7; PRISSE, *Mon.* xiii; STEINDORFF, *Die Blütezeit des Pharaonenreichs* (1900), p. 147, Abb. 123; (1926), p. 171, Abb. 159; BREASTED, *A History of Egypt* (1905), fig. 140 opposite p. 370; DARESSY, op. cit. in *Rec. de Trav.* xv, plate opposite p. 52 and pp. 51-8; texts, LEPSIUS MSS.* Diary, pages at end, 56-60; ll. 18-19, see LÉVY, *L'Atour et le Schène* in *Rec. de Trav.* xv. 165. Statue of Nefertiti, DAVIES, op. cit. v, pl. xlv [bottom left].

STELA R. Year 6.

Double scene, King, Queen, and two princesses, with twenty-nine (?) lines text (much effaced) below, and remains of statue-groups on north side. View, id. ib. pl. xlii [left], cf. p. 26; text, DARESSY, op. cit. 52-8; texts of princesses, and parts of text below, LEPSIUS MSS.* Diary, pages at end, 53-5.

STELA Q. Year 6.

Double scene, King, Queen, and two princesses, adoring the Aten, with twenty-seven lines text (lower part destroyed) below, and destroyed statue-group on either side. View, DAVIES, op. cit. v, pls. xlii [right], cf. xli [upper], p. 26. Fragments, in Cairo Mus. and in Melbourne Mus., id. ib. pl. xlv [upper right].

STELA P. Year 6. (Destroyed by gunpowder.)

Fragments with royal heads remaining from double scene of King, Queen, and two princesses adoring the Aten, and statue-groups on either side, see id. ib. pp. 25-6.

STELA N. Year 6.

King, Queen, and two princesses, adoring the Aten, with twenty-six lines text below, and statue-groups on either side. Scene and view, id. ib. pls. xxxiii [top right], xxxiv [bottom middle], xl [lower], cf. p. 25; view, STEINDORFF, *Durch die Libysche Wüste zur Amonsoase*, p. 5, Abb. 3; id. *Vorläufiger Bericht* [&c.] in *Berichte der Phil. Hist. Kl. d. K. Sächs. Gesell. d. Wiss. zu Leipzig*, vol. 52 (1900), plates opposite pp. 211, 212; scene, L. D. iii. 110 a, cf. *Text*, ii, p. 129 [lower]; heads, L. D. iii. 295 [45, 48]. Statues of princesses on south side, DAVIES, op. cit. v, pl. xlv [bottom right]. Head of King from statue-group on right side, presented by STEINDORFF to Berlin Mus. in 1900, SCHÄFER, *Kunstwerke aus der Zeit Amenophis' iv* in *Amtliche Berichte*, xxxiv, pp. 145-6, Abb. 76, reprinted in *Ä.Z.* lii, p. 81, Abb. 14. (Head of Queen from same group is in Leipzig Univ. Mus.)

STELA M. Year 4. (Much effaced.)

King, Queen, and one or two princesses, adoring the Aten, with text below, see id. ib. p. 25.

STELA K. Year 4.

King, Queen, Princess Merytaten, and added figure of Princess Meketaten with attendant, adoring the Aten, and twenty-one columns text, and eighty lines text below. Text and view, id. ib. pls. xxix, xxx, xxxvii [right], xxxviii, cf. p. 25; scene and twenty-five lines text below, L. D. iii. 110 b, cf. *Text*, ii, p. 129 [top].

STELA J. Year 6. (Much destroyed.)

King, Queen, and two princesses, adoring the Aten, with eight lines text below. Views, DAVIES, op. cit. ii, pl. xxv [lower right]; v, pl. xxxvi [top right], cf. p. 24.

Miscellaneous.

(From El-'Amarna, but exact provenance unknown.)

Stelae.

Amenophis IV, Nefertiti, and three princesses, in Berlin Mus. 14145, STEINDORFF, *Die Blütezeit des Pharaonenreichs* (1900), p. 157, Abb. 132; (1926), p. 184, Abb. 173; id. *Die Kunst der Ägypter*, p. 240; SCHÄFER, *Kunstwerke aus El-Amarna*, ii, pl. 4; id. *Amarna in Religion und Kunst*, pl. 28; id. op. cit. in *Amtliche Berichte*, xxxiv, pp. 140-1, Abb. 71, reprinted in *Ä.Z.* lii, p. 78, Abb. 9; SCHUBART, *Von der Flügelsonne zum Halbmond*, pl. 23 [upper]; BORCHARDT, *Porträts der Königin Nofret-ete*, p. 13, Abb. 10, cf. p. 11, Abb. 8; heads of King and Queen, id. *Aus der Arbeit an den Funden von Tell el-Amarna in Mitteil. d. Deutsch. Or. Gesell.* March 1917, No. 57, pp. 6-7, Abb. 3, 4; SCHÄFER, *Altes und Neues zur Kunst und Religion von Tell el-Amarna in Ä.Z.* lv, pp. 12-13, Abb. 20, 21; NEWBERRY in ROSS, *The Art of Egypt through the Ages*, p. 165; texts, *Aeg. Inschr. Mus. Berlin*, ii. 255-6.

Amenophis IV and Smenkhkarē' at table, dedicated by Pa-se , Officer, in Berlin Mus. 17813, SCHÄFER, *Kunstwerke aus El-Amarna*, ii, pl. 7; id. *Amarna in Religion und Kunst*, pl. 30; id. op. cit. in *Amtliche Berichte*, xxxiv, pp. 136-7, Abb. 68, reprinted in *Ä.Z.* lii, p. 76, Abb. 6; BORCHARDT, *Porträts der Königin Nofret-ete*, p. 9, Abb. 6; NEWBERRY, *Akhenaten's Eldest Son-in-law 'Ankhkheprurē'* in *J.E.A.* xiv, pl. iv [1], cf. p. 7; texts, *Aeg. Inschr. Mus. Berlin*, ii. 115.

Small alabaster stela, Amenophis IV raising Aten-cartouches, in Berlin Mus. 2045, SCHÄFER, *Kunstwerke aus El-Amarna*, ii, pl. 9 [right]; STEINDORFF, *Die Blütezeit des Pharaonenreichs* (1900), p. 155, Abb. 129; (1926), p. 168, Abb. 157.

Upper part of stela, Tut'ankhamūn offers flowers to Amūn and Mut, in Berlin Mus. 14197, ERMAN, *Geschichtliche Inschriften aus dem Berliner Museum in Ä.Z.* xxxviii. 113; text, *Aeg. Inschr. Mus. Berlin*, ii. 117, cf. *Ausführ. Verzeichnis* (1899), p. 128; figure of King, SCHÄFER, op. cit. in *Ä.Z.* lv, pl. 7 [1], cf. p. 17.

Stela of Terurē' , in Berlin Mus. 14122, SPIEGELBERG and ERMAN, *Grabstein eines syrischen Söldners aus Tell Amarna in Ä.Z.* xxxvi, pl. xvii, pp. 126-9; STEINDORFF, op. cit. (1900), p. 58, Abb. 50; (1926), p. 56, Abb. 49; MEYER, *Darstellungen der Fremdvölker*, 828; SCHÄFER, *Kunstwerke aus El-Amarna*, ii, pl. 11; id. *Amarna in Religion und Kunst*, pl. 53; id. op. cit. in *Amtliche Berichte*, xxxiv, pp. 143-4, Abb. 74, reprinted in *Ä.Z.* lii, p. 80, Abb. 12; ROEDER, *Ägypter und Hethiter in Der Alte Orient*, xx (1919), Abb. 1, cf. p. 6; text, *Aeg. Inschr. Mus. Berlin*, ii. 117, cf. *Ausführ. Verzeichnis* (1899), p. 129.

Reliefs.

Fragment, Amenophis IV worships the Aten in Temple of Tuthmosis IV at Akhetaten, WILKINSON, *Modern Egypt and Thebes*, ii, 73, cf. 77; id. MSS.* v. 29 [lower left]; BORCHARDT, op. cit. in *Mitteil. d. Deutsch. Or. Gesell.* March 1917, No. 57, p. 29, Abb. 18 (from WILKINSON).

Block, Amenophis IV, Nefertiti, and princess adore the Aten, in Cairo Mus., NEWBERRY in ROSS, op. cit. p. 164; CARRÉ, *Voyageurs et écrivains français en Égypte*, ii, plate opposite p. 60; see MASPERO, *Guide* (1914), p. 135 [468].

Fragment with heads of Amenophis IV and Nefertiti, in Berlin Mus. 14511, SCHÄFER, *Der König im Fenster in Amtliche Berichte*, xl, No. 3, p. 62, Abb. 34; id. *Kunstwerke aus El-Amarna*, ii, pl. 5; id. *Amarna in Religion und Kunst*, pl. 22; id. op. cit. in *Amtliche Berichte*, xxxiv, pp. 137-8, Abb. 69, reprinted in *Ä.Z.* lii, p. 77, Abb. 7; BORCHARDT, *Porträts der Königin Nofret-ete* [&c.], p. 26, Abb. 19; texts, *Aeg. Inschr. Mus. Berlin*, ii. 253.

Fragment of family scene showing Queen (?) seated, in Brit. Mus. 24431, *Guide to the Third and Fourth Egyptian Rooms* (1904), fig. on p. 100; *Guide to the Fourth, Fifth, and Sixth Egyptian Rooms* (1922), fig. on p. 127; BORCHARDT, op. cit. p. 18, Abb. 13, cf. p. 17, note 2.

Head of Amenophis IV in relief, in Berlin Mus. 17540, id. op. cit. in *Mitteil. d. Deutsch. Or. Gesell.* Oct. 1912, No. 50, p. 32, Abb. 22; SCHÄFER, *Kunstwerke aus El-Amarna*, ii, pl. 2; id. *Amarna in Religion und Kunst*, pl. 16; id. op. cit. in *Amtliche Berichte*, xxxiv, pp. 132-3, Abb. 65, reprinted in *Ä.Z.* lii, p. 74, Abb. 3.

Fragment with head of Amenophis IV, in Berlin Mus. 14512, id. *Kunstwerke aus El-Amarna*, ii, pl. 3; id. *Amarna in Religion und Kunst*, pl. 11; id. *Das Wesen der 'Amarnakunst'* in *Mitteil. d. Deutsch. Or. Gesell.* March 1926, No. 64, pl. 4 opposite p. 58; id. op. cit. in *Amtliche Berichte*, xxxiv, pp. 140-1, Abb. 72, reprinted in *Ä.Z.* lii, p. 79, Abb. 10; id. op. cit. in *Ä.Z.* lv, pl. 2 [3], cf. p. 8; id. *Ägyptische und heutige Kunst*, p. 57, Abb. 68.

Fragments of bas-reliefs of Amenophis IV, in Cairo Mus.; texts, LEGRAIN, *Répertoire*, Nos. 295-7.

Fragment with head of noble, in Brit. Mus. 52943, *Guide to the Egyptian Collections* (1930), p. 169, fig. 91; BUDGE, *Egyptian Sculptures in the British Museum*, pl. xxvi; WEIGALL, *Ancient Egyptian Works of Art*, 206 [left lower]; see *Guide to the Fourth, Fifth and Sixth Egyptian Rooms* (1922), p. 128 [68].

Fragments of bas-reliefs from tombs, servant sweeping, and heads of blindfolded men from procession, in Brit. Mus. 47988, 47989, *Guide to the Egyptian Collections* (1930), p. 168, fig. 90; HALL, *Egyptian Antiquities in British Museum Quarterly* (1926), No. 2, pl. xxiii [a, b]; id. *A Portrait of Smenkhkerē* (?) [&c.] in *J.E.A.* xvii, pl. xv [1, 2], cf. p. 165.

Part of large block with mourners, in Institute of Arts, Detroit, Michigan, CAPART, *Documents pour servir à l'étude de l'Art Égyptien*, i, pl. 58; J. W[ALTHER], *Tomb relief from Tel el Amarna* in *Bull. of the Detroit Institute of Arts of the City of Detroit*, vol. vi, No. 4, Jan. 1925, p. 41.

Group of Egyptians and negroes from a tomb, now in Bologna Mus., WEIGALL, op. cit. 207.

Sculptor's trial-piece, Nefertiti offers flowers to Amenophis IV, in Berlin Mus. 15000, SCHÄFER, *Kunstwerke aus El-Amarna*, ii, pl. 6; id. *Amarna in Religion und Kunst*, pl. 33; id. op. cit. in *Amtliche Berichte*, xxxiv, pp. 133-4, Abb. 66, reprinted in *Ä.Z.* lii, p. 75, Abb. 4; id. op. cit. in *Ä.Z.* lv, pl. 3 [1], cf. p. 18; BISSING, *Denkmäler*, 83; BORCHARDT,

op. cit. p. 26, Abb. 22; BREASTED, *A History of Egypt* (1905), fig. 141 opposite p. 370; STEINDORFF, *Die Blütezeit des Pharaonenreichs* (1900), p. 153, Abb. 128; (1926), p. 185, Abb. 175; King, WEIGALL, op. cit. 197 [right]; NEWBERRY, *Note on the Sculptured Slab No. 15,000 in the Berlin Museum* in *J.E.A.* xiv, pl. xiv, cf. p. 117.

Sculptor's trial-piece with head on each side (from Amherst Collection), in Upsala Mus. 238, LUGN, *Ausgewählte Denkmäler aus ägyptischen Sammlungen*, pl. xix.

Sculptor's trial-piece with lion and owl, in Berlin Mus. 17946, SCHÄFER, *Kunstwerke aus El-Amarna*, ii, pl. 10; id. *Amarna in Religion und Kunst*, pl. 52; head of Amenophis IV on back, id. op. cit. in *A.Z.* lv, pl. 2 [4].

Two sculptor's trial-pieces, woman suckling baby, and portrait-sketch of Amenophis IV or Smenkhkarē, in Brit. Mus. 15973, 26810, HALL, op. cit. in *J.E.A.* xvii, pl. xv [3, 4], cf. p. 165; portrait-sketch, *Guide to the Egyptian Collections* (1930), p. 357, fig. 196.

Fragments of reliefs, sculptures, &c., including head of man of Mitanni (?), horse's head, head of princess, and figure of Queen, PETRIE, *Tell el Amarna*, pl. i [2-4, 7, 11, 14, 15], cf. pp. 40-1.

Fragments of inscribed reliefs, sculptures, &c., in Berlin Mus. 11523, 11604, 12000-1, 12035-7, 12040-1, 12044-5, 12075, *Aeg. Inschr. Mus. Berlin*, ii. 222-3, 259, 262.

(For bas-relief, in Florence Mus. 5412, found in house at Castel Goffredo near Cremona in Italy, see *Bibl.* iii, p. 205.)

Statues.

Model bust of Amenophis IV, perhaps from house of sculptor D̄hutmosi (cf. supra p. 202), in Louvre E. 11076, BORCHARDT, op. cit. in *Mitteil. d. Deutsch. Or. Gesell.* Oct. 1913, No. 52, pl. 4 [left]; BÉNÉDITE, *A propos d'un buste égyptien récemment acquis* [&c.] in *Monuments Piot*, xiii, pls. i, ii, cf. pp. 1-27; id. *Les Antiquités Égyptiennes au Musée du Louvre* in *Gazette des Beaux Arts*, xxxvi (1906), plate opposite p. 364; MASPERO, *Egyptian Art*, plate opposite p. 134; BOREUX, *Guide-Catalogue Sommaire*, ii (1932), pl. lxi, cf. pp. 447-9; id. *L'Art Égyptien*, pl. xxxviii; STEINDORFF, *Die Blütezeit des Pharaonenreichs* (1926), p. 162, Abb. 153; id. *Die blaue Königskrone* in *Ä.Z.* liii, p. 62, Abb. 7; WEIGALL, op. cit. 195; CURTIUS, *Die Antike Kunst*, p. 168, Abb. 127.

Limestone head of Amenophis IV, in Cairo Mus. 746, BORCHARDT, *Statuen und Statuetten* (Cat. Caire), iii, pl. 138, cf. p. 71.

Quartzite head of Amenophis IV, in New York, Metropolitan Mus., *A Handbook of the Egyptian Rooms* (1911), p. 85, fig. 40.

Wooden figure of Amenophis IV, probably from here, in Berlin Mus. 21836, SCHÄFER, *Kunstwerke aus El-Amarna*, ii, frontispiece; id. *Amarna in Religion und Kunst*, pl. 19.

Alabaster figure of princess, probably from here, in Berlin Mus. 17951, id. *Kunstwerke aus El-Amarna*, ii, pl. 9 [left].

Painted limestone head of princess, bought in Cairo, perhaps from here, in Berlin Mus. 14113, id. ib. pl. 8; id. *Amarna in Religion und Kunst*, pl. 26; id. op. cit. in *Amtliche Berichte*, xxxiv, pp. 141-2, Abb. 73, reprinted in *Ä.Z.* lii, p. 79, Abb. 11; BISSING, *Denkmäler*, 45 A; STEINDORFF, op. cit. (1900), p. 158, Abb. 133; see *Ausführ. Verzeichnis* (1899), p. 128.

Quartzite head of Princess Merytaten (?), in Copenhagen, Ny Carlsberg Mus. Æ.I.N. 1663, MOGENSEN, *La Collection égyptienne*, pl. vi [A 12], cf. p. 7; BORCHARDT, *Porträts der Königin Nofret-ete* [&c.], p. 12, Abb. 9; MOGENSEN, *Les œuvres d'art de Tell-el-Amarna* [&c.] in *Bull. Inst. Fr. Arch. Or.* xxx, pl. ii [6], cf. p. 460.

Black basalt head of princess, in Copenhagen, Ny Carlsberg Mus., id. ib. pl. iii, cf. pp. 461-2.

Green feldspath head of princess, in Louvre E. 11678, BÉNÉDITE, *Sur une tête de princesse de la famille d'Akhounaten* in *Monuments Piot*, xxvii, pl. xi, cf. pp. 113-18; see BOREUX, *Guide-Catalogue Sommaire*, ii (1932), 354-5.

Statue, Amenophis IV and Nefertiti holding hands (seen at a dealer's in Cairo), BORCHARDT, op. cit. p. 26, Abb. 21, cf. p. 28.

Alabaster fragment of base of seated statue, with cartouches of Amenophis IV and Nefertiti, and part of limestone monument of Amenophis IV, in Brit. Mus. 880, 1083, see *Guide*, Sculpture (1909), pp. 123-4 [436, 437].

Fragment of statue of Amenophis IV, lower part of seated double-statue of Amenophis IV and princess, and three small heads (one female), in Florence Mus. 6321, 6320, 6349-51; remains of texts, SCHIAPARELLI, *Museo Archeologico di Firenze*, pp. 466-7 [1724-1728].

(For base of statue (?) of Amenophis IV, copied by BONOMI in a garden in Cairo, but probably from here, see supra p. 70.)

Various.

Offering-table, Dyn. XII, in Cairo Mus. 23020, KAMAL, *Tables d'Offrandes* (Cat. Caire), pl. x, cf. p. 18.

Fragment of plaque of Sitamün , daughter of Amenophis III, in Oxford, Ashmolean Mus., PETRIE, *Tell el Amarna*, pl. xiii [16]; see GAUTHIER, *Le Livre des Rois*, ii. 340 [6].

Red granite dish with names of Amenophis IV and Nefertiti, in Cairo Mus. 18491; text, BISSING, *Steingefässe* (Cat. Caire), p. 98; part, LEGRAIN, *Répertoire*, No. 294.

Fragments of granite vase; text with cartouches of Amenophis IV, CHAMPOLLION, *Not. Descr.* ii. 466 [bottom].

Fragments of an alabaster vase and enamelled box of Smenkhkaré' (?), PETRIE, op. cit. pl. xiii [37, 38]; see GAUTHIER, op. cit. ii. 363 [iv, v].

Other fragments of inscribed vases, PETRIE, op. cit. pl. xiii [13-15, 17-26, 28-35, 39].

Pyramidion of an official in the temple of the Aten, from a tomb, now in Berlin Mus. 14123; texts, *Aeg. Inschr. Mus. Berlin*, ii. 234-5; see *Ausführ. Verzeichnis* (1899), p. 130.

Royal Tomb

In ravine up Wâdi Abû Ḥaṣāh el-Baḥri (called Darb el-Hamzaouï by BOURIANT, LEGRAIN, and JÉQUIER). See sketch-plan of ravine, PENDLEBURY, *Report on the clearance of the Royal Tomb at El-Amârna* in *Ann. Serv.* xxxi. 125. (See plans, supra pp. 194, 226.)

Complete, BOURIANT, LEGRAIN, and JÉQUIER, *Les Tombes de Khouitatonou* in *Mém. Inst. Fr. Arch. Or.* viii, pls. i-xiii, pp. 5-23; see BARSANTI, *Sulla scoperta della Tomba del Faraone Amenofi IV* in *Rendiconti Reale Accad. Lincei* (1894), pp. 245-8; BOURIANT, *Notes de Voyage* in *Rec. de Trav.* xviii. 144-50; PENDLEBURY, op. cit. in *Ann. Serv.* xxxi. 123-4. Plan and section, BOURIANT, &c., op. cit. in *Mém. Inst. Fr. Arch. Or.* viii, p. 5, fig. 1; plan, and views of entrance, NEWBERRY in *Archaeological Report* (1892-3), p. 12.

Corridor A.

Twenty-five fragments of ushabtis of Amenophis IV, in Cairo Mus.; texts and one head, BOURIANT, &c., op. cit. pp. 6-7, and 8, fig. 2; one fragment, PETRIE, *A History of Egypt*, ii (1896), p. 222, fig. 137; cartouches, LEGRAIN, *Répertoire*, No. 290.

Entrance to Pillared Hall E.

(1) Jamb. Woman, perhaps Princess Meketaten; remains of text at bottom, BOURIANT, op. cit. in *Rec. de Trav.* xviii. 149.

Pillared Hall E.

(2) At top, women mourners from burial scene (?), BOURIANT, &c., op. cit. in *Mém. Inst. Fr. Arch. Or.* viii, p. 10, fig. 3; see BOURIANT, op. cit. in *Rec. de Trav.* xviii, 149-50.

(3) Pillar. Remains of text of a 'royal acquaintance pure of hands', id. ib. 150.

Room IV.

Stela, King, Queen, and two princesses worship the Aten ('Wilbour stela'), found in débris, now in Cairo Mus. 34174, BOURIANT, &c., op. cit. in *Mém. Inst. Fr. Arch. Or.* viii, p. 12, fig. 4, and pp. 11, 14; BISSING, *Denkmäler*, 82; BORCHARDT and REISNER, *Works of Art*, 27 [upper]; LACAU, *Stèles du Nouvel Empire* (Cat. Caire), pl. lxiv, pp. 12-13; MASPERO and ROEDER, *Führer* (1912), pl. 32 [a]; upper part of Queen, BORCHARDT, *Porträts der Königin Nofret-ete*, p. 11, Abb. 7; see LEGRAIN, *Répertoire*, No. 288.

Room α.

(4) Remains of seven registers of foreigners, BOURIANT, &c., op. cit. pl. v.

(5)-(6) King, Queen, and four princesses, soldiers, and attendants, worship the Aten in Temple with courtiers below; remaining names of 'Ankhesenpa-aten and Nefer-neferu-aten the younger, id. ib. p. 19.

(7) Nine registers soldiers, including negroes, Libyans, and Asiatics, and chariots, id. ib. pl. iv.

(8) Upper part, Royal family mourning, and followers before the Aten, lower part, King and Queen mourning Princess Meketaten on bier, and wailing women, id. ib. pl. vi; BISSING, *Denkmäler*, Text to 82 [fig.]

(9)-(10) King, Queen, and Princesses Merytaten, Meketaten (?), and 'Ankhesenpa-aten worship the Aten in court of Temple, while escort and chariots wait outside pylon, BOURIANT, &c., op. cit. pl. i, p. 17.

(10) At bottom, remains of scene of ostriches, gazelles, &c., in desert, below the Aten, KUENTZ, *La danse des autruches* in *Bull. Inst. Fr. Arch. Or.* xxiii. 86; DAVIES, *The Graphic Work of the Expedition in N.Y. Metro. Bull.* Pt. ii, Dec. 1923, p. 53, fig. 22.

(11) Seven registers, soldiers, negroes, and Asiatics, BOURIANT, &c., op. cit. pls. ii, iii.

Fragment of red granite sarcophagus of [Princess Meketaten], with cartouches of Amenophis III and Amenophis IV, found in east corner by BARSANTI, in Cairo Mus.; cartouches, BOURIANT, &c., op. cit. p. 15; LEGRAIN, *Répertoire*, No. 286.

Room γ.

(12)-(13) Three registers, mourners and funeral offerings before King and Queen (destroyed), and two princesses lamenting beside bier (Princess Meketaten on bier destroyed), BOURIANT, &c., op. cit. pls. vii-ix, p. 21 [A, B].

(14)-(15) Princess Meketaten on altar, and Royal family with three princesses, followed by two registers courtiers and mourners, and funeral offerings below, id. ib. pls. x-xiii.

(16) Remains of offerings, see id. ib. p. 23.

Finds.

Corner of red granite sarcophagus of a princess, with head of Queen in bas-relief, in Berlin Mus. 14524, SCHÄFER, *Kunstwerke aus El-Amarna*, ii, pl. 15; id. *Amarna in Religion und Kunst*, pl. 56; id. *Altes und Neues zur Kunst und Religion* [&c.] in *Ä.Z.* lv, p. 3, Abb. 3, pl. i [5].

Fragment of alabaster lid with bas-relief of a vulture, in Cairo Mus. 18492, see BISSING, *Steingefässe* (Cat. Caire), p. 99; LEGRAIN, *Répertoire*, No. 302 [B].

QUARRIES

See PETRIE, *Tell el Amarna*, p. 4; TIMME, *Tell el-Amarna*, pp. 50-3, with Abb. 54-8.

LIMESTONE QUARRY H. Dyn. XVIII.

Cartouche of Queen Teye, PETRIE, op. cit. pl. xlii [lower middle], cf. p. 39; see TIMME, op. cit. p. 52, Abb. 57.

ALABASTER QUARRY G. Middle Kingdom (?)

See WILKINSON, *Modern Egypt and Thebes*, ii, p. 72; PETRIE, op. cit. p. 4. View, WILKINSON MSS.* 'Egyptian Drawings', No. 60 (in the possession of Seymour de Ricci in Paris), see DE RICCI, *An Album of Drawings by Sir J. G. Wilkinson in Studies presented to F. Ll. Griffith*, p. 475.

ALABASTER QUARRY L. Dyn. XIX.

Names of Ramesses II and Merneptah, see PETRIE, op. cit. p. 4.

HET-NUB 

ALABASTER QUARRIES

Rock inscriptions, ANTHES, *Die Felseninschriften von Hatnub*, passim; see FRASER, *Hat-Nub* , in *P.S.B.A.* xvi. 74-82; MÖLLER, *Bericht über die Aufnahme der hieroglyphischen und hieratischen Felseninschriften im Alabasterbruch von Hatnub in Mittelägypten in Sitzungsber. d. Preuss. Akad. d. Wiss.* (1908), xxxii. 679-90; PETRIE, *Tell el Amarna*, pp. 3-4. Map showing positions of quarries, id. ib. pl. xxxiv.



MAIN QUARRY P. Old Kingdom—Sesostris I.

Hieratic graffiti, BLACKDEN and FRASER, *Collection of Hieratic Graffiti from the Alabaster Quarry of Hat-Nub*, passim. Plans, ANTHES, op. cit. pls. 1, 3.

(For details and positions in quarry, see id. ib. pp. 109-12.)

Incised inscriptions.¹

I-VIII. Hieroglyphic inscriptions including names of Khufu, Pepy I, Merenrē I, and Pepy II, id. ib. pls. 4-5, cf. pp. 13-14; see MÖLLER, op. cit. pp. 679-82; omitting I and VIII, and figure in VI, BLACKDEN and FRASER, op. cit. pl. xv [1 right, 2-5, 7]; Nos. II, III, V, VI (incomplete), PETRIE, op. cit. pl. xlii [lower middle]; No. I, MÖLLER, op. cit. p. 681, Abb. 1; TIMME, *Tell el-Amarna*, pp. 42-3, Abb. 43-4; transcription of No. III, text of year 25 of Pepy I, SETHE, *Urk.* i. 95-6 (14).

IX, X. Hieroglyphic inscriptions of Dḥutinakht II , Nomarch of the Hare-nome², temp. Mery . . . and of Dḥutinakht III , Great chief of the Hare-nome, ANTHES, op. cit. pls. 7 [upper], 6, cf. pp. 14-16; omitting figures and cartouche, BLACKDEN and FRASER, op. cit. pl. xv [9, 1 left]; No. IX (omitting figure), PETRIE, op. cit. pl. xlii [lower middle].











XI. Six small hieratic texts, Middle Kingdom; α and β , ANTHES, op. cit. pl. 7 [lower], cf. pp. 16-17; one, BLACKDEN and FRASER, op. cit. pl. xv [8]; part of α with name of Sebkhotp, PETRIE, op. cit. pl. xlii [lower middle].









XIV. Text of Any (?)  . . . , Head of sculptors of the Lord of the Two Lands, New Kingdom, ANTHES, op. cit. pl. 8 [bottom], cf. p. 17; BLACKDEN and FRASER, op. cit. pl. xv [10].



¹ The numbering is that of ANTHES.

² See Deir el-Bersha, supra p. 177 et seq.

Ink Graffiti.

1-8. Hieratic texts of Old Kingdom officials, Meru  temp. Teti, Isesi  and Ser , 'Antiiu  Derkhesef , S'ankhy , Idi , Khnem'ankh , good name 'Ankhy , and Ser  (same as Ser, supra), all temp. Pepy II, ANTHES, op. cit. pls. 9-12, cf. pp. 18-23; see MÖLLER, op. cit. p. 682; omitting 1 and 8, and part of 2, BLACKDEN and FRASER, op. cit. pls. iii-vi, xv[6]; cartouche of Pepy II in No. 3, PETRIE, op. cit. pl. xlii [lower middle].

9-29, 31-2, 42. Hieratic texts of officials in the time of the Middle Kingdom nomarchs of the Hare-nome,¹ Iḥa I , 'Aḥanakht , Neḥeri I , Dḥutinakht V , Dḥutihotp I , and Dḥutinakht IV, ANTHES, op. cit. pls. 13, 14 [omitting right upper], 15-20, 21 [upper, bottom right], 22, 24 [right], 26, 28 [left lower, right], 29, 30, pp. 25-66, 67-8, 72-3; see MÖLLER, op. cit. pp. 683-9; texts, omitting 9, 14, 15, 18, 19, 21, 26, 27, 29, 31, 32, 42, BLACKDEN and FRASER, op. cit. pls. i, ii, vii-ix, xi-xiv; No. 14, text of Neteruhotp , Overseer of boats, year 4 of nomarch Neḥeri, MÖLLER, op. cit. p. 686, Abb. 2, cf. pp. 687-8; TIMME, op. cit. p. 43, Abb. 45; hieroglyphic transcription of texts of Nos. 16 and 24 of Kay , Vizier, year 5 of nomarch Neḥeri, and of Nos. 17 and 23 of Dḥutinakht , Great priest of Thoth, GRIFFITH and NEWBERRY, *El-Bersheh*, ii, pls. xxii, xxiii, cf. pp. 47-53.

30. Text of Kanakht  and Sebkhotp , Middle Kingdom, ANTHES, op. cit. pl. 23 [right], p. 66.

33-41, 43-48. Undated hieratic graffiti, Middle Kingdom, some in Berlin Mus., id. ib. pls. 14 [right upper], 21 [lower middle and left], 23 [left], 24 [left], 25, 27, 28 [left upper], pp. 69-72, 73-6.

49. Amenemḥēt , Chancellor of the King of Lower Egypt, &c., with two dogs and offering-bringer, and text of year 31 of Sesostri I, id. ib. pl. 31, pp. 76-8; text, BLACKDEN and FRASER, op. cit. pl. x; date (with wrong cartouche), PETRIE, op. cit. pl. xlii [lower middle]; see GRIFFITH and NEWBERRY, op. cit. ii, pp. 53-4.

SOUTH QUARRY R. Amenemḥēt II-Hyksos Period. A mile south of Main Quarry.

See MÖLLER, op. cit. p. 689. Plan, ANTHES, op. cit. pl. 2 [6].

Incised Inscriptions.

XII. Eight small texts, some with name of Teti , id. ib. pl. 8 [top], cf. p. 17; name of Teti, PETRIE, op. cit. pl. xlii [lower middle].

XIII. Graffito of Si-ameny , Overseer of workmen, seated before offering-table, with four dogs, temp. Sesostri III, ANTHES, op. cit. pl. 8 [middle], cf. p. 17; BLACKDEN and FRASER, op. cit. pl. xv [12]; texts, PETRIE, op. cit. pl. xlii [lower middle], cf. p. 4.

Ink Graffiti.

50. Hieroglyphic text, year 20 of Amenemḥēt III, ANTHES, op. cit. pl. 32 [lower], cf. p. 78; BLACKDEN and FRASER, op. cit. pl. xv [11].

51. Sep. . . (?)  with servant, Middle Kingdom, ANTHES, op. cit. pl. 33, p. 78.

52. Representation of statue, dogs and huntsman with text (name lost). Hyksos Period, id. ib. pl. 32 [upper], pp. 78-80.

¹ See Deir el-Bersha, supra p. 177 et seq.

QUARRY NORTH-EAST OF HET-NUB.

See BORCHARDT, *Ausgrabungen in Tell el Amarna in Mitteil. d. Deutsch. Or. Gesell.* Oct. 1913, No. 52, p. 51.

Relief, priest sacrificing gazelle before five gods, Late Period, id. ib. Dec. 1914, No. 55, p. 11, Abb. 2, cf. pp. 9-11, and Abb. 1; TIMME, *Tell el-Amarna*, p. 46, Abb. 50.

XI. BETWEEN EL-'AMARNA AND ASYÛṬ

(SHEIKH 'AṬĪYA TO MANQABÂD)

EAST BANK

SHEIKH 'AṬĪYA

TOMB OF NEFERKAU , Royal priest; Overseer of prophets; Overseer of the scribes of the Land. Old Kingdom.

Titles from two fragments, LEGRAIN, *Notes archéologiques prises au Gebel Abou Fodah* in *Ann. Serv.* i. 13.

QUṢEIR EL-'AMARNA

ROCK-TOMBS. Old Kingdom.

PEPY-'ANKH the eldest , Lector; Overseer of prophets; &c. Temp. Merenrē' I-Pepy II.

See BLACKMAN, *The Rock Tombs of Meir*, i, pp. 8 [top], 9-10 [2].

Hall.

Pillars.

(1) (destroyed) and (2). Texts, CHABÂN, *Sur une nécropole de la VI^e dynastie, à Koçeir el-Amarnah* in *Ann. Serv.* iii. 252 [middle]; name and titles at (2), WRZSZINSKI, *Bericht über die Photographische Expedition* [&c.], p. 58.

South Room.

(3) False door; texts, CHABÂN, op. cit. 252-3.

KHUENUKH , Lector; Elder of the toilet-chamber; Overseer of herds (?) of *Thentet*-cows; &c. Dyn. VI. South of last.

See BLACKMAN, op. cit. i, p. 8, No. 2. Plan and section, QUIBELL, *Sur une nécropole de la VI^e dynastie* [&c.] in *Ann. Serv.* iii, pp. 254, 255, figs. 1, 2; plan, KAMAL, *Fouilles à Dara et à Qoçéir el-Amarna* in *Ann. Serv.* xii. 136.

Façade.

(1)-(2) Architrave with three lines of titles, and at each end deceased and wife with son, see QUIBELL, op. cit. 258 [bottom].

(2) False door; texts, KAMAL, op. cit. 137; incomplete, CHABÂN, op. cit. in *Ann. Serv.* iii. 251; text on upper lintel, QUIBELL, op. cit. 255.

Entrance.

(3) Thickness, deceased standing; titles, id. ib. 258 [near top]; ll. 2-4, BLACKMAN, *The Pharaoh's Placenta and the Moon-God Khons* in *J.E.A.* iii. 243 [bottom].

(4) Thickness, remains of painted scene with text mentioning souls of Pe and Nekhen, see QUIBELL, op. cit. 258 [bottom].

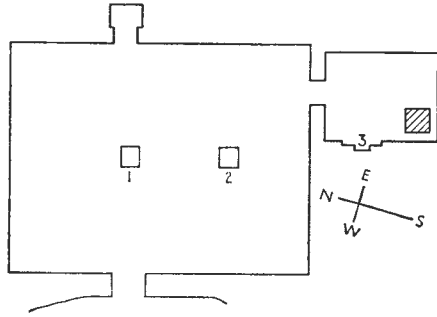

QUSEIR EL-'AMARNA. Pepy-ankh.

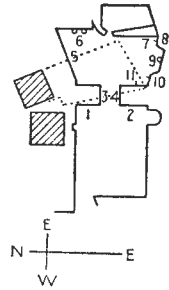

QUSEIR EL-'AMARNA.
Khuenekh. From
QUIBELL in *Ann.
Serv.* iii, p. 254,
fig. 1.

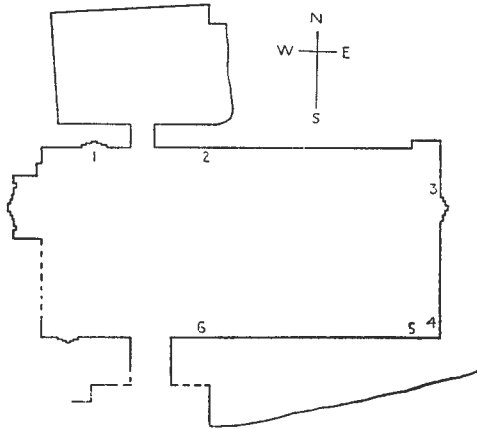

Tomb 67. Henku. From DAVIES, ii, pl. xxii [lower].

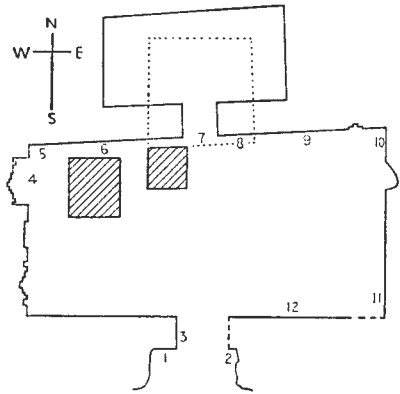

Tomb 72. Rē-ḥem. From DAVIES, ii,
pl. xvi [lower].

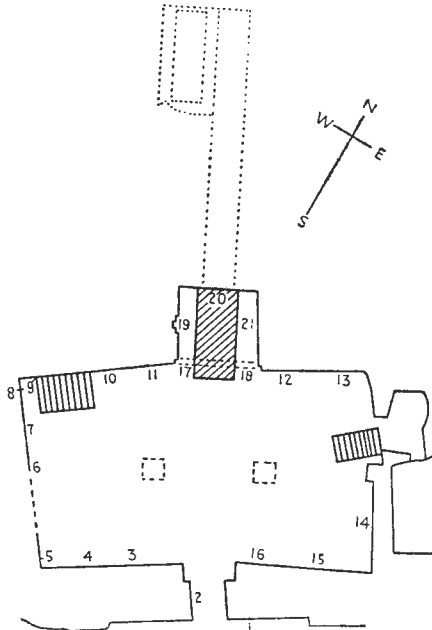

Tomb 8. Ibi. From DAVIES, i, pl. ii.

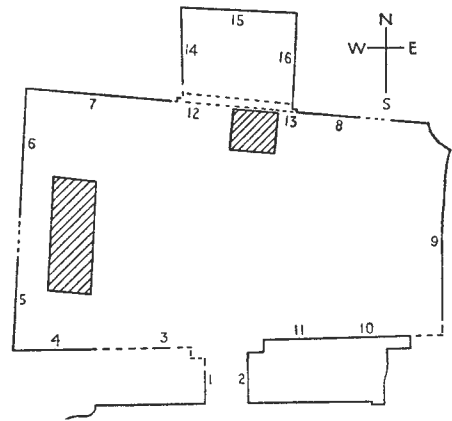

Tomb 12. Za'u. From DAVIES, ii, pl. ii.

Plans of Tombs 8, 12, 67, and 72, are from DAVIES, *The Rock Tombs of Deir el Gebrāwi*.

Hall.

(5) Deceased before offerings, and son Khuenukh-Neferḥōtep  censuring; texts, KAMAL, op. cit. 138; titles, WRESZINSKI, op. cit. p. 57; name of son, QUIBELL, op. cit. 256 [top].

(6) Statues of deceased and wife with list of offerings, and offering-text above; texts, KAMAL, op. cit. 138-9.

(7) Deceased before offerings, and offering-bringers below; texts, id. ib. 140; texts of offering-bringers, QUIBELL, op. cit. 256.

(8) and (10) East of statue, three registers, wife, daughter, and woman, west of statue, three registers, man with oryx, man with gazelle, and girl with calf; texts, id. ib. 257; KAMAL, op. cit. 141 [bottom].

(9) Below statue, deceased and wife seated before offerings; texts, id. ib. 141 [upper].

(11) Deceased harpooning fish, and four servants below; upper part, QUIBELL, op. cit. pp. 257-8 and fig. 3; texts, KAMAL, op. cit. 142 [top].

TEMPLE OF ḤATHOR. Roman. (Entirely destroyed.)

Plan, *Descr. de l'Égypte, Ant.* iv, pl. 63 [2], cf. *Texte*, iv, p. 306.

Cartouche of Caesar Germanicus, CHABÂN, op. cit. in *Ann. Serv.* iii. 250.

GEBEL ABÛ FÔDA

QUARRIES. In side of Wâdi Magberi (south of Quṣeir el-'Amarna).

Ḥathor capitals; sketch of one, *Descr. de l'Égypte, Ant.* iv, pl. 62 [3-5]; NESTOR L'HÔTE MSS.* 20396, 139; CAILLIAUD, *Arts et Métiers*, pl. 14 [2]; PETRIE, *A Season in Egypt*, pl. xxv [middle right], cf. p. 33 [51]; see CLÉDAT, *Notes archéologiques et philologiques* in *Bull. Inst. Fr. Arch. Or.* i, p. 92, fig. 4.

Roman bas-relief opposite the capitals, King offers to Thoth, Rē' (?), and Ḥathor, and to Amūn, Min, and another god; sketch, NESTOR L'HÔTE MSS.* 20396, 137; cartouches and remains of texts, CLÉDAT, op. cit. 92-3; two head-dresses, LEGRAIN, *Notes archéologiques prises au Gebel Abou Fodah* in *Ann. Serv.* i. 10, cf. 9.

Demotic graffito left of last, CLÉDAT, op. cit. p. 93, fig. 6.

Pillar opposite Ḥathor-capital. Graffiti, id. ib. p. 95, figs. 23, 25.

DARB EL-KARAÏB. One kilometre north of Deir el-Amîr Tâdros.

Three demotic graffiti mentioning Ḥor, son of Peduēsi, and date of year 25 of a Ptolemy, LEGRAIN, op. cit. 7, cf. 3.

ROCK OVERLOOKING NILE. Just north of Deir el-Amîr Tâdros, opposite station of Beni Qurra.

Cartouches of Sethos II, WEIGALL, *Miscellaneous notes* in *Ann. Serv.* xi. 171; see LEGRAIN, op. cit. 3, 5.

EL-MA'ÂBDA

GROTTO.

Scene of mummy on bier attended by Anubis, with Nephthys and Isis and two priests (?), BURTON MSS.* 25636, 24; WILKINSON MSS.* xxxviii. 158 [lower].

ROCK-TOMB (destroyed). Dyn. VI. North of El-Ma'âbda (exact position not stated).



West wall. Stela; remains of offering-text and sketch of stela, L. D. *Text*, ii, p. 151.

DEIR EL-GABRĀWI
ROCK-TOMBS.¹ Old Kingdom.

Complete, DAVIES, *The Rock Tombs of Deir el Gebrāwi*, vols. i, ii; see NEWBERRY, *The Archaeological Survey of Egypt in Archaeological Report* (1892-3), pp. 14-15. View, id. ib. p. 9.



North Group.

Plan of site showing positions of tombs, DAVIES, op. cit. i, pl. i, cf. ii, pl. i [top].

38. NEB-IB , Overseer of . . . of the divine chancellor.
See id. ib. ii, pp. 33-4. Plan, id. ib. on pl. xxvii [lower right].
North wall. Two sons before deceased and wife, id. ib. pl. xxi [top right]; frieze-text with names of lion-goddess Mati of Aakemt, SETHE, *Urk.* i. 80 (3).
39. HENḲU , called KHETETI , Nomarch of the Anteopolite nome; Overseer of the south; Chief lector; &c.
See DAVIES, op. cit. ii, pp. 31-3. Plan, id. ib. pl. xxvii [lower left].



Hall.

Sketch-plans of north, east, and west walls, with inscriptions, id. ib. pl. xxviii; three dancing-girls from recess in east wall, id. ib. pl. xv [right]; deceased seated, from north wall, WILKINSON MSS.* xii. 134 [bottom].

46. ISI , called RĒ'-HEM , Nomarch of the Anteopolite nome; Chief lector; &c.
See DAVIES, op. cit. ii, p. 33.

Hall.

False door, and texts from south wall, id. ib. pl. xxi [bottom right].

67. HENḲU , called IY . . . F , Nomarch of the Anteopolite nome; Vizier; Overseer of the Pyramid-town; &c. (See plan, supra p. 240.)
See DAVIES, op. cit. ii, pp. 27-31. Plan, section, and elevation, id. ib. pl. xxii [lower]. Sketch-plans of north, east, and south walls, id. ib. pl. xxvi [top and bottom].

Hall.

(1) Upper part, deceased and wife before offering-table with titles above, id. ib. pl. xxvi [top left, middle left].



(2) Deceased with family harpooning fish, and servants preparing bed, id. ib. pl. xxiii; deceased and son, and text above them, WILKINSON MSS.* xii. 135.

(3)-(4) Biographical text, and deceased with son, DAVIES, op. cit. ii, pls. xxv, xxiv, xxvi [middle right, bottom right], cf. p. 30; SETHE, *Urk.* i. 76-9 (2).

(5)-(6) Offering-bringers before deceased, DAVIES, op. cit. ii, pl. xxvi [bottom left].

Lintel (?) with deceased seated, and remains of titles, WILKINSON MSS.* xii. 134 [middle].

¹ The marginal tomb-numbers are those of DAVIES.

72. RĒ'-HEM , called ISI , Nomarch of the Anteopolite nome; Overseer of the Pyramid-town; &c. (See plan, supra p. 240.)

See DAVIES, *The Rock Tombs of Deir el Gebrâwi*, ii, pp. 19-27. Plan, section, and elevation, id. ib. pl. xvi [lower].

Entrance.

(1) and (2) Remains of lintel and jambs, id. ib. pl. xxi [middle lower].

(3) Thickness. Remains of offering-text above deceased, id. ib. pl. xxi [middle bottom]; WILKINSON MSS.* xii. 136.

Outer Hall.

(4) False door; lintel and jambs, DAVIES, op. cit. ii, pl. xxi [bottom left (A, B, C)]; lintel, WILKINSON MSS.* xii. 137 [left].

(5) Deceased and wife before offering-table, offering-list, and servants below; deceased and wife, and offering-text above servants, DAVIES, op. cit. ii, pl. xvii [left], p. 22.

(6)-(7) Four registers, deceased fowling from dahabiya, men reaping corn, dancing-girls and harpist, man leading hyena (destroyed) and men picking fruit, id. ib. pl. xvii [right].

(8) Deceased with family and servants, id. ib. pl. xviii.

(9) Upper part, two sailing-boats, and scribes before deceased, lower part, three registers, metal-workers and tending cows before deceased, id. ib. pl. xix; sketch of sailing-boats, WILKINSON MSS.* xii. 137 [right].

(10)-(11) Funeral procession before deceased. Top register, oxen, funeral boats, and offering-bringers, second register, cattle crossing water and dancing-girls, third register, preparing food-offerings, fourth register, making beer and bread, DAVIES, op. cit. ii, pl. xx.

(12) Remains of fowling scene; crane, and graffito of ship, id. ib. pl. xv [middle upper and bottom right].

95. NAME LOST.

See id. ib. p. 34. Plan, section, and elevation, id. ib. pl. xxvii [upper].

Hall.

West wall. Offering-bringers before deceased; remains of texts, id. ib. pl. xxi [middle right].

South Group.

Plan of site showing positions of tombs, DAVIES, *The Rock Tombs of Deir el Gebrâwi*, i, pl. i.

2. HETEP-NEB , First under the King.

See id. ib. p. 24. Plan, id. ib. pl. xxi [bottom left].

Shrine.

Rear wall. Text above tablet, id. ib. pl. xxiii [middle left].

8. IBI , Nomarch of the Anteopolite nome; Assistant-prophet of the Pyramid of Neferkarē'; &c. Dyn. VI. (See plan, supra p. 240.)

See id. ib. i, pp. 8-24. Plan, sections, and elevation, id. ib. pls. ii, ii A.

Façade.

(1) Middle Kingdom graffito with name of Amenemhēt; text, id. ib. pl. xxiii [middle lower]; SAYCE, *Gleanings from the Land of Egypt in Rec. de Trav.* xx. 173.

Entrance.

(2) Thickness. Deceased and wife; texts, DAVIES, op. cit. i, pl. xxiii [upper middle].

Hall.

(3) Deceased with family fowling in marshes, and four registers men bringing products of marshes, id. ib. pl. v; texts of catching birds and throwing the boomerang, MONTET, *Les Scènes de la Vie Privée*, 4 [10, 14], 18 [3], cf. note 4.

(4) At top, netting fowl, and below, deceased watching five registers, picking fruit, gathering papyrus, bringing products in canoes, and cattle crossing water, DAVIES, op. cit. i, pl. vi.

(5)–(6) (North part destroyed). Top and second registers, girls dancing, men singing before deceased in palanquin (destroyed), third to fifth registers, coffin drawn in procession, and funeral procession in boats, id. ib. pls. x, ix [top], viii [left], cf. frontispiece; sketch of two girls dancing, WILKINSON MSS.* xii. 134 [top].

(7) Four registers, stock-taking with scribes and defaulters, man beaten, dyers, and musicians, before deceased, DAVIES, op. cit. i, pl. viii.

(8) and (9) Two scenes, each of three registers, offerings, cooking, and butchers, id. ib. pls. ix [right], xii [left]. Two registers at bottom of (9), wife before table, and servant with incense, id. ib. pl. ix [bottom left].

(10) Four registers agriculture before deceased and wife, id. ib. pl. xii [middle and right].

(11) Five registers, animals in desert with hunter, registration of cattle with cow calving, bull-fight, milking, and goats browsing, before deceased and family, id. ib. pl. xi.

(12)–(13) Upper part, three registers, stone-masons, carpenters, sculptors, dwarf bead-makers, and metal-workers, id. ib. pls. xiv, xiii; texts of men making sphinx from second register, and texts of third register, SAYCE, op. cit. in *Rec. de Trav.* xx. 174; text above deceased, id. ib. 173 [bottom left]. Lower part, three registers, boat-building and scribes, cranes and geese in pens, and wife and sons, before deceased, DAVIES, op. cit. i, pls. xv, xvi.

(14) Deceased seated before offerings, procession of estates, tending cattle and ploughing, with deceased and wife beyond, id. ib. pl. xvii; texts, SETHE, *Urk.* i. 144–5 (32) c. Biographical text above scenes, DAVIES, op. cit. i, pl. xxiii [top]; SETHE, *Urk.* i. 142–4 (32) A, B.

(15) Upper part, two registers, eight officials, and men preparing fish and boatmen fighting before deceased, lower part, fishing with draw-net, DAVIES, op. cit. i, pls. iv, xx, cf. xxi [upper].

(16) Deceased with family spearing fish, id. ib. pl. iii.



Entrance to Shrine.

(17)–(18) Lintel. Titles of deceased, id. ib. pl. xviii [upper].

Shrine.

(19) and (21) Scenes, on each wall, offering-bringers and offering-list before deceased, id. ib. pls. xvii, xix.

(20) Painted false door, and deceased and wife receiving gifts from family, id. ib. pl. xviii [lower]; false door, SAYCE, op. cit. in *Rec. de Trav.* xiii. 67 [bottom right], with id. ib. xx. 173 [bottom right]; part of texts of false door, WILKINSON MSS.* xii. 133, cf. 82 [top left].

12. ZA'U , called SHEMAI = , Nomarch of the Anteopolite nome; Inspector of prophets and Forester of the Pyramid of Neferkarē'; &c.; and his son ZA'U , Nomarch of the Anteopolite nome; Assistant-prophet of the Pyramid of Neferkarē'; &c. Dyn. VI. (See plan, supra p. 240.)

See DAVIES, *The Rock Tombs of Deir el Gebrāwi*, ii, pp. 1–13. Plan and section, id. ib. pl. ii.

Entrance.

(1) and (2) Thicknesses. Texts above Za'u-Shemai, id. ib. pl. xxi [top left], cf. p. 3.

Hall.



(3) Za'u-Shemai with son (both partly destroyed) fowling, and two servants (?) above, id. ib. pls. iii, iv [left].

(4) Netting fowl at top, and three registers, butchers, bringing bull, &c., and spearing fish from canoe, before Za'u, id. ib. pl. iv; bitch and pups beneath Za'u's chair, and some fishes, id. ib. pl. xv [bottom left and lower middle].

(5) Five registers, female and male dancers, funeral procession with bier and boats, behind Za'u and Za'u-Shemai, id. ib. pl. vii; second boat from fourth register, id. ib. pl. xiv; dancing-girls (omitting first one) from top register, WILKINSON MSS.* xviii. 28 [upper]; boats from fifth register, id. ib. 27; texts between registers, SAYCE, op. cit. in *Rec. de Trav.* xx. 172 [bottom]-173 [top].

(6) Four registers agricultural scenes before Za'u and wife, DAVIES, op. cit. ii, pl. vi, and frontispiece; WILKINSON MSS.* xviii. 25, 26; texts, SAYCE, op. cit. in *Rec. de Trav.* xx. 172 [middle left], 173; text above third register, id. ib. xiii. 67 [top right]; name and titles of wife, WILKINSON MSS.* xii. 81 [upper right].

(7) Two scenes, Za'u-Shemai seated before offerings with sons, daughters, and officials above, and standing watching seven registers bringing animals, DAVIES, op. cit. ii, pls. ix, xv [top left]; texts above both figures of deceased, and family and officials from first scene, WILKINSON MSS.* xii. 130, 131, 81 [lower]; texts of second scene and of wife and son in first scene, SAYCE, op. cit. in *Rec. de Trav.* xx. 171 [top left, middle, and lower middle left]; part of text above deceased standing, id. ib. xiii. 67 [right, near top].

(8) Za'u and Za'u-Shemai facing each other, and five registers industries before Za'u seated under canopy, DAVIES, op. cit. ii, pl. x; omitting text above Za'u seated, WILKINSON MSS.* xviii. 29-30, xii. 81 [upper left and middle], 82 [top right]; text above father and son, and name of sculptor Pepysonb  | , true name Nesy (?) , below arm of Za'u-Shemai, SAYCE, op. cit. in *Rec. de Trav.* xiii. 66 [upper], 67 [right middle]; name of sculptor and texts of industries, id. ib. xx. 171 [bottom]-172 [top].

(9) Za'u-Shemai followed by Za'u (destroyed) watching scene, upper part, Za'u-Shemai in palanquin and procession of estates with himself seated before offering-text above, lower part, cattle, butchers, donkeys, and offerings, before Za'u-Shemai seated, DAVIES, op. cit. ii, pl. viii; offering-text, and text below palanquin, SAYCE, op. cit. in *Rec. de Trav.* xx. 172 [middle lower], 171 [middle left]; deceased and offering-text, WILKINSON MSS.* xviii. 28 [lower right].

(10) Five registers, boatmen fighting, papyrus-gathering, and netting fish from canoe, before Za'u-Shemai, DAVIES, op. cit. ii, pl. v [left].

(11) Za'u-Shemai with Za'u harpooning fish, id. ib. pl. v [right]; the two figures, WILKINSON MSS.* xviii. 28 [lower left].

Entrance to Shrine.

(12)-(13) Lintel. Titles of Za'u-Shemai, DAVIES, op. cit. ii, pl. xii [upper]; WILKINSON MSS.* xii. 132 [middle lower]; SAYCE, op. cit. 170 [bottom].

Shrine.

(14) Remains of offering-bringers, painted false door, offering-list, and deceased before offerings, DAVIES, op. cit. ii, pl. xi; offering-text at top of false-door, WILKINSON MSS.* xii. 132 [top].

(15) Three registers of servants, painted false door, and Za'u and wife, DAVIES, op. cit. ii, pl. xii [lower]; text of Za'u and wife, SAYCE, op. cit. 171 [right].

(16) Offering-list above Za'u before offerings, and long account of his father's burial, with painted false door, DAVIES, *op. cit.* ii, pl. xiii, cf. p. 13; long text, SETHE, *Urk.* i. 145-7 (33); SAYCE, *op. cit.* in *Rec. de Trav.* xiii. 66-7; titles above Za'u, and three columns from long text, WILKINSON MSS.* xii. 132 [middle upper and bottom].

14. WEḤA , Intimate.

See DAVIES, *The Rock Tombs of Deir el Gebrâwi*, i, p. 24. Plan, id. ib. pl. xxi.

Hall.

West wall. Remains of text above tablet, id. ib. pl. xxiii [lower middle left].

16. TEKHYT , Unique royal ornament.

See id. ib. p. 25. Plan, id. ib. pl. xxi.

Hall.

North wall. Remains of text above tablet, id. ib. pl. xxiii [lower middle].

28. SENBSEN .

See id. ib. p. 25.

Hall.

North wall. Remains of scene, id. ib. pl. xxiii [bottom left].

33. MERUT .

See id. ib. p. 25. Plan, id. ib. pl. xxii [33] (wrongly numbered 34).

Hall.

South wall. Lintel and jambs of false door, id. ib. pl. xxiii [bottom right].

41. NEFERTEP-WA (?) , Intimate.

See id. ib. p. 26. Plan, id. ib. pl. xxi.

Hall.

East wall. Remains of text of tablet, id. ib. pl. xxiii [bottom middle].

42. NEFERNEF-KHETU .

See id. ib. p. 26. Plan, id. ib. pl. xxi.

Hall.

East wall. Offering-text above tablet, id. ib. pl. xxiii [upper middle right].

Various.

Fragment of false door; text, KAMAL, *Rapport sur les fouilles de Saïd bey Khachaba au Dêir-el-Gabraouï* in *Ann. Serv.* xiii. 161 [3°].

EL-ATÂWLA

Near 'Arab el-Borg.

TEMPLE. Middle Kingdom.

Blocks of Sesostri I, and block of King Ḥarnedyotf, son of 'Amu, , Dyn. XIII; texts of latter, DARESSY, *Notes et Remarques* in *Rec. de Trav.* xvi. 133; KAMAL, *Rapport sur la nécropole d'Arabe-el-Borg* in *Ann. Serv.* iii. 80.

CEMETERY.

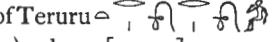
Altar of Teruru , Saite, in Cairo Mus. 23037, KAMAL, *Tables d'Offrandes* (Cat. Caire), pl. xv [upper], p. 30; cf. id. op. cit. in *Ann. Serv.* iii. 81.

Three statues of Sebknakht , Steward, Middle Kingdom, perhaps from Deir el Bersha, in Cairo Mus., MASPERO, *Sur trois statues du premier empire thébain* in *Ann. Serv.* iii, plate and p. 95.

BISRA

ALABASTER QUARRIES.

Fragment with name of Queen Aḥmosi Nefertere, L. D. iii. 3 c, and *Text*, ii, p. 158; WEIGALL, *Miscellaneous Notes* in *Ann. Serv.* xi, p. 176, fig. 11.





WEST BANK

MEIR

ROCK-TOMBS.¹

See BLACKMAN, *The Rock Tombs of Meir*, 4 vols. Views of site, id. ib. i, pl. xii [1, 2].



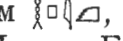

Group A.

- A 1. NI'ANKH-PEPY-KEM     and HEPI-KEM , Overseer of Upper Egypt; Chancellor of the King of Lower Egypt; Overseer of prophets; &c. Temp. Pepy I.

See BLACKMAN, op. cit. i, pp. 5, 9, 14-15.

Two wooden statues of deceased, and statuettes of servants, in Cairo Mus. 60, 236-254, BORCHARDT, *Statuen und Statuetten* (Cat. Caire), i, pls. 15, 49-55, pp. 52-3, 154-63; Nos. 237, 240, 241, 243, 245-6, 248-51, GRÉBAUT, *Le Musée Égyptien*, i. xxxviii-xliii; Nos. 241, 240, 243 [left], 245, 244, BORCHARDT, *Die Dienerstatuen aus den Gräbern des alten Reiches* in *Ä.Z.* xxxv. 121 [middle and right], 124, 125 [right], 127 [upper], 129 [top]; Nos. 236 (deceased) and 241, WEIGALL, *Anc. Eg. Works of Art*, 69; No. 248, BISSING, *Eine altägyptische Mädchentracht* in *Ä.Z.* xxxvii. 77 [fig.].

Model-boats, in Cairo Mus. 4880-93, REISNER, *Models of Ships and Boats* (Cat. Caire), pls. xii-xv, xxvii-xxviii, pp. 51-60, cf. p. v.

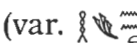
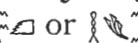
- A 2. PEPY-'ANKH the youngest  , good name HENI-KEM   (var.  or ) Overseer of the duckpool; Chancellor of the King of Lower Egypt; Overseer of prophets; &c.; son of Ni'ankh-Pepy-kem (Sebkhotp). Temp. Pepy II.

See BLACKMAN, op. cit. i, pp. 6, 10; titles, KAMAL, *Rapport sur les fouilles* [&c.] in *Ann. Serv.* xii. 97 [upper].

Hall.

(1) Four registers, bread-making before deceased, vineyard, wine-making, and row of four statues; fourth register, statues, BLACKMAN, *The Ka-House and the Serdab* in *J.E.A.* iii, pl. xxxix [1], cf. p. 254.

¹ The marginal tomb-numbers are those of BLACKMAN.

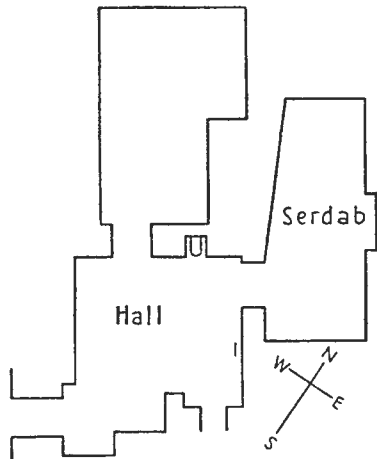

MEIR. Tomb A 2. Pepy-'ankh.

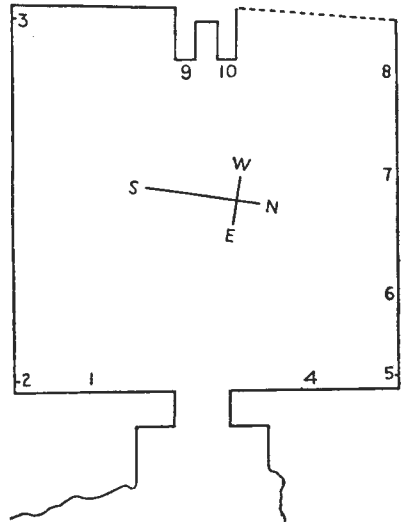

MEIR. Tomb B 1. Senbi. From BLACKMAN, *The Rock Tombs of Meir*, i, pl. i.

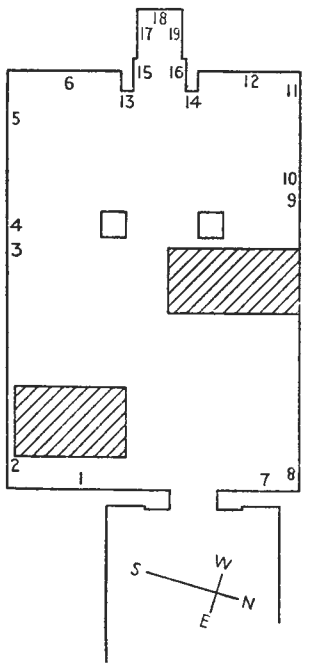

MEIR. Tomb B 2. Ukh-hotp.
From BLACKMAN, *The Rock Tombs of Meir*, ii, pl. i.

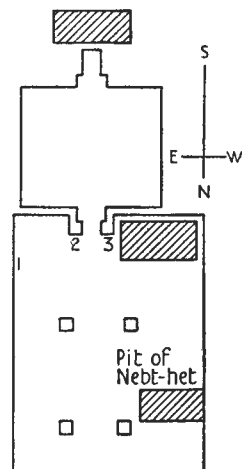

MEIR. Tomb B 3. Senbi.
From KAMAL in *Ann. Serv.* xi, p. 10, fig. 1.

Serdab.

'Statue House'; view of three walls with representations of statues in three registers, id. ib. pl. xxxix [2].

Findings.

Coffin of Hēpi $\text{𓆎} \text{𓆏}$, First under the King, Lector, found in pit in front of entrance; texts, KAMAL, op. cit. 108.

- A 3. UKH-ḤOTP $\text{𓆎} \text{𓆏}$, Nomarch; Overseer of sealers; son of Iam $\text{𓆎} \text{𓆏} \text{𓆏} \text{𓆏}$.
Temp. Sesostris I–Amenemḥet II.

See BLACKMAN, *The Rock Tombs of Meir*, i, pp. 8, 11–12 [4].

Hall.

Niche in rear (north) wall. Lintel and jambs; texts, CLÉDAT, *Notes archéologiques et philologiques* in *Bull. Inst. Fr. Arch. Or.* ii. 43.

Sepulchral Chamber.

Wooden door; name and titles, KAMAL, op. cit. 109.

Coffin and canopic box; texts, id. ib. 109–12.

- A 4. HĒPI-KEM $\text{𓆎} \text{𓆏} \text{𓆏}$, Overseer of Upper Egypt; Chancellor of the King of Lower Egypt; Overseer of prophets; &c. Temp. Pepy II–Merenrē II (Menthisuphis).

See BLACKMAN, op. cit. i, pp. 6, 10–11 [5].

Sarcophagus Chamber.

Offerings and funerary furniture; titles of deceased above, id. ib. pp. 10–11.

South of Group A.

TOMB OF UKH-ḤOTPI $\text{𓆎} \text{𓆏} \text{𓆏}$.

Sepulchral Chamber.

Coffins of deceased and Kayt $\text{𓆎} \text{𓆏} \text{𓆏}$, with inscribed linen, and fragment of stela; texts, KAMAL, op. cit. in *Ann. Serv.* xii. 98–9, 101.

VARIOUS.

Coffins and canopic boxes and jars of Kay $\text{𓆎} \text{𓆏} \text{𓆏}$, good name Hēnent $\text{𓆎} \text{𓆏} \text{𓆏}$, and of Senbi $\text{𓆎} \text{𓆏} \text{𓆏}$, Steward, and coffins of Kayt $\text{𓆎} \text{𓆏} \text{𓆏}$, and of Seni $\text{𓆎} \text{𓆏} \text{𓆏}$; texts, id. op. cit. in *Ann. Serv.* xi. 19–22, 26, 27–31; statuette of Senbi and canopic jar of Kay, in New York, Metropolitan Mus., *A Handbook of the Egyptian Rooms* (1911), pp. 61, 63, figs. 30, 31.

Group B.

- B 1. SENBI $\text{𓆎} \text{𓆏} \text{𓆏}$, Nomarch; Overseer of prophets; Chancellor of the King of Lower Egypt; &c.; son of Ukh-ḥotp. Temp. Amenemḥet I.

Complete, BLACKMAN, *The Rock Tombs of Meir*, i, pp. 8, 11 [1], 18–34, with plates passim. Plan and section, id. ib. pl. i. Views, id. ib. pls. xiii [2], xiv, xv; id. *The Archaeological Survey: Report for 1913, 1914* in *J.E.A.* i, pl. xxviii opposite p. 184.

Hall.

(1) Deceased with servant hunting in desert, id. *The Rock Tombs of Meir*, i, pls. vi–viii, xxii [3, 4], xxiii, xxiv; WRESZINSKI, *Löwenjagd im alten Ägypten* in *Morgenland*, xxiii (1932), pl. iv, Abb. 10.

(2)-(3) Top register, Beja herdsmen with cattle, priests, butchers, and offerings, before deceased seated, second and third registers, bulls fighting, cow calving, bringing cattle, overthrowing bull, butchers, and offering-bringers, before deceased and wife, BLACKMAN, op. cit. i, pls. xi, x, ix, xxv-xxix, xxx [2], xxxi [1, 2], xxxii; cf. ii, pls. xix [3], xx [1, 3, 4]; men overthrowing bull, WEIGALL, *Anc. Eg. Works of Art*, 83 [upper].

(4) Remains of scenes of industries, BLACKMAN, op. cit. i, pl. v.

(5)-(7) Lower part, top register, men fishing in marshes and bringing fowl, second register, agricultural scenes, id. ib. pls. iv [lower]-iii [lower], xvii [2], xx, xxi [2-4], xxx [1]; cf. ii, pl. xix [2].

(6)-(8) Upper part, top register, steward followed by girls with sistra and men bringing furniture, &c., second register, harper, men with castanets, male dancers, wrestlers, and priests, before deceased with servants, id. ib. i, pls. iii [upper]-ii [upper], xviii, xix, xxi [1].

(8) Lower part, two scenes, deceased with wife fishing and fowling in marshes, id. ib. pls. ii [lower], xvi, xvii [1], xxii [2], and frontispiece.

(9)-(10) Lintel and jambs of niche; texts, id. ib. p. 34, cf. pl. xxii [1]; south part of lintel, LEGRAIN, *Notes sur la nécropole de Meir* in *Ann. Serv.* i. 70.

B 2. UKH-ḤOTP $\frac{\text{ⲕ}}{\text{ⲟ}} \frac{\text{ⲕ}}{\text{ⲟ}}$, Nomarch of the Atef-nome; Chancellor of the King of Lower Egypt; Overseer of prophets of Hathor Mistress of Cusae; &c.; son of Senbi (B 1). Temp. Sesostris I.

Complete, BLACKMAN, op. cit. ii, passim; cf. i, pp. 8, 11 [2]. Plan and section, id. ib. ii, pl. i. View, id. ib. pl. xxi [1]; id. *The Archaeological Survey: Report for 1913, 1914* in *J.E.A.* i, pl. xxvii [1] opposite p. 182.

Hall.

(1) Sketch in ink of two men with donkey, id. *The Rock Tombs of Meir*, ii, pl. v [1].

(2)-(3) Deceased with attendant hunting in desert, with priests and offering-list above, id. ib. pls. viii, vii, xxx [3], xxxi, xxxii, [1] xxxiii [2, 3], xxxv [4].

(4)-(5) Upper part, offering-list and offerings before deceased, lower part, Beja and man with cattle, and offering-bringers, before deceased and wife, id. ib. pls. vi, xxviii-xxix, xxx [1, 2], xxxii [2], cf. xix [1]; Beja herdsman with cattle, id. *The Archaeological Survey* in *Archaeological Report* (1911-12), pl. viii, fig. 1 opposite p. 10; id. in ROSS, *The Art of Egypt through the Ages*, p. 144 [1]; WEIGALL, op. cit. 83 [lower]; Beja herdsman, CLÉDAT, *Notes sur quelques figures égyptiennes* in *Bull. Inst. Fr. Arch. Or.* i, p. 22, fig. 2.

(6) Top register, harper, official, and men with castanets, before deceased and wife with maid-servant, second and third registers, girls with sistra and bulls fighting before deceased, BLACKMAN, *The Rock Tombs of Meir*, ii, pls. xv, xxxii [3], xxxiv, xxxv [1-3]; bulls fighting, from third register, WRESZINSKI, *Der Gott Wḥ* in *O.L.Z.* xxxv, plate opposite p. 524, cf. 521-3.

(7) Deceased and wife with maid-servants, BLACKMAN, op. cit. ii, pl. v [2].

(8)-(9) Top register, lassoing and bringing bulls, second register, fowl netted and musicians, third register, boatmen fighting, making canoes and gathering papyrus, before deceased with wife, id. ib. pls. iv, iii, xxi [2], xxii-xxvii, cf. xx [2]; Beja herdsman with ox from top register, and Beja holding on to boat from third, CLÉDAT, op. cit. pp. 21, 23, figs. 1, 3; musicians from second register, and men carrying and binding papyrus with old man talking to boat-builder from third register, BLACKMAN in ROSS, op. cit. p. 143; part, id. op. cit. in *J.E.A.* i, pl. xxvii [2] opposite p. 182.

(10)-(11) Three registers wrestlers and offering-bringers before deceased and wife with servants, BLACKMAN, *The Rock Tombs of Meir*, ii, pl. ii, cf. xxv [1 left].

(12) Upper part, unfinished scene, priests and offerings before deceased with two officials, id. ib. pl. x. Lower part, two registers, men bringing oryx, gazelles and fowl (unfinished), and Beja with two bulls and an official, before deceased and wife, id. ib. pl. xi.

North Pillar. Figures of deceased on four sides, id. ib. pl. xvi.

Niche.

(13) and (14) Jambs; offering-texts, id. ib. pl. xii [1, 3], cf. xxxiii [1]; CHASSINAT, *Notes prises à Méir* in *Rec. de Trav.* xxii. 74 (Tombe No. 2); text of south jamb, LEGRAIN, op. cit. in *Ann. Serv.* i. 71.

(15) and (16) Thicknesses; three offering-bringers on each side, BLACKMAN, op. cit. ii, pls. xiv [1], xiii [2].

(17) and (19) Deceased and wife on each side, id. ib. pls. xiv [2], xiii [1].

(18) Deceased before altar, and butcher below, id. ib. pl. xii [2].

Inscribed funerary libation-vase, probably from this tomb, in Brit. Mus., HALL, *Recent Egyptian and Assyrian Acquisitions in Brit. Mus. Quarterly*, v, pl. xxii [middle], cf. p. 50.

B 3. SENBI $\overline{\text{sn}}\overline{\text{b}}\overline{\text{t}}$, Hereditary prince; Overseer of prophets; son of Ukh-hotp (B 2). Temp. Sesostris I-Amenemhêt II. (Unfinished.)

See BLACKMAN, op. cit. i, pp. 8, 11 [3]. Plan, KAMAL, *Rapport sur les fouilles* [&c.] in *Ann. Serv.* xi, p. 10, fig. 1.

Outer Hall.

(1) Painted stela of sister Mersi $\overline{\text{m}}\overline{\text{r}}\overline{\text{s}}\overline{\text{i}}$; texts, CHASSINAT, op. cit. in *Rec. de Trav.* xxii. 75 [top].

Entrance to Inner Hall.

(2)-(3) Lintel and jambs, id. ib. 74 [bottom].

Sarcophagus Chamber of Nebt-het $\overline{\text{n}}\overline{\text{b}}\overline{\text{t}}\overline{\text{h}}\overline{\text{t}}$, Mayor's daughter.

Plan, KAMAL, op. cit. pp. 11, 15, figs. 2, 3.

Coffin of Nebt-het, usurped from Ukh-hotp, and canopic box, in New York, Metropolitan Mus., *A Handbook of the Egyptian Rooms* (1911), p. 59, fig. 27, p. 61, figs. 28, 29, cf. p. 67, fig. 32; texts of exterior of coffin and canopic box, CHASSINAT, op. cit. pp. 11-14.

B 4. UKH-HOTP $\overline{\text{u}}\overline{\text{k}}\overline{\text{h}}\overline{\text{h}}\overline{\text{o}}\overline{\text{t}}\overline{\text{p}}$, Nomarch; Overseer of prophets of Hathor Mistress of Cusae; Director of every divine office; Lector of the Great Ennead; &c.; son of Ukh-hotp (A 3) and Mersi $\overline{\text{m}}\overline{\text{r}}\overline{\text{s}}\overline{\text{i}}$. Temp. Amenemhêt II.

Complete, BLACKMAN, op. cit. iii, passim; cf. i, pp. 9, 12 [5]. Plan and sections, id. ib. iii, pl. i. Views, id. ib. pls. xxxiii, xxxiv.

Outer Hall.

(1) Remains of industries, with figure of Khnemhotp, Steward of the treasury, and carpenters, &c., id. ib. pl. v [2].

(2)-(3) Deceased (destroyed) and family fishing in marsh, and remains of scene of deceased fowling and men fishing with draw-net, id. ib. pls. vi-viii.

(4) Remains of list of nomarchs of Cusae with wives, id. ib. pls. x, xi, xxix, xxxv [1], xxxvi [1], xxxvii [1, 2], pp. 16-19; genealogy, CHASSINAT, op. cit. in *Rec. de Trav.* xxii. 76-7.

(5) Officials before deceased, followed by his relations, BLACKMAN, op. cit. iii, pls. xiv, xxx, xxxviii [1].

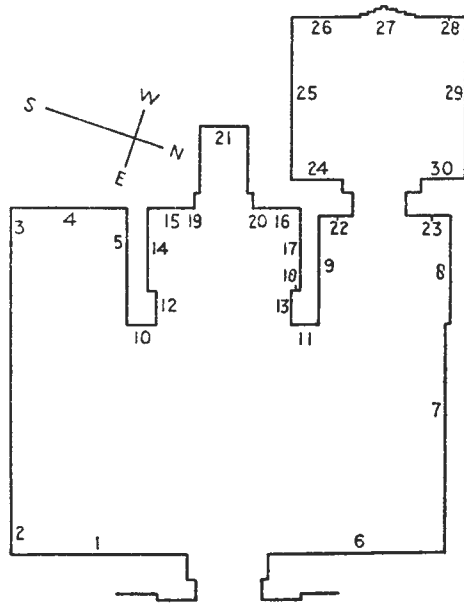

MEIR. Tomb B 4. Ukh-hotp. From BLACKMAN, *The Rock Tombs of Meir*, iii, pl. i.

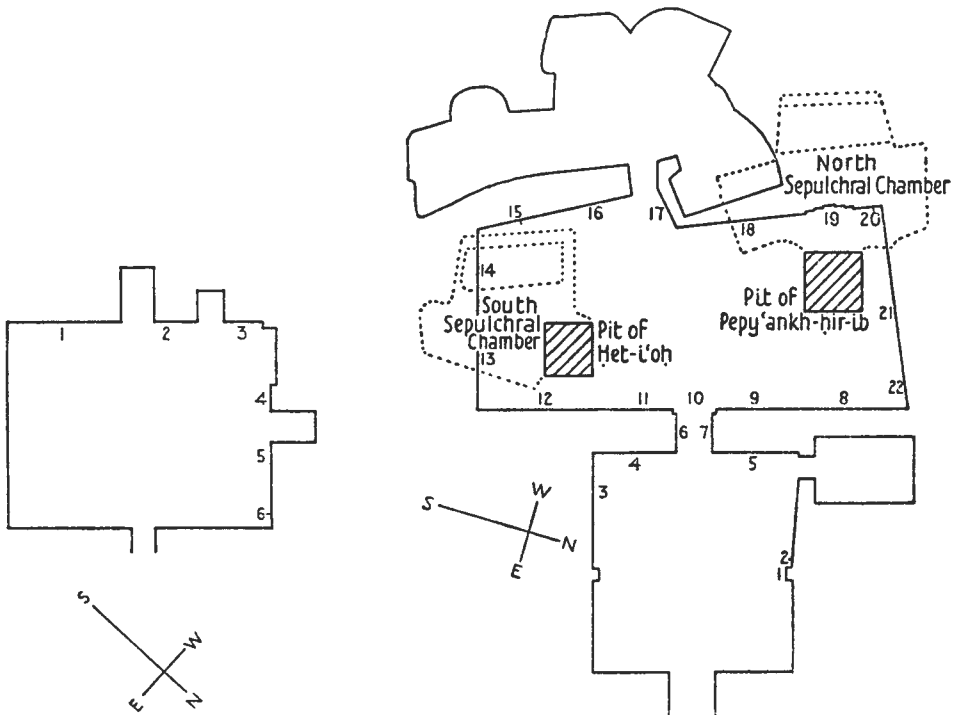

MEIR. Tomb C 1. Ukh-hotp.

MEIR. Tomb D 2. Pepy'ankh-hir-ib. From BLACKMAN, *The Rock Tombs of Meir*, iv, pls. i, ii.

(6) Remains of hunting-scene with net, id. ib. pl. v [1].

(7) Upper part, remains of marsh-scene, lower part, two registers, tending and bringing cattle, id. ib. pl. iv.

(8) Upper part, remains of musicians before deceased (destroyed), lower part, destroyed scene of counting cattle before deceased, id. ib. pls. ii, iii.

(9) Upper part, deceased in destroyed scene, lower part, remains of bringing cattle and offerings to deceased, id. ib. pls. xii, xiii.

Entrance to Shrine.

(10) and (11) Jambs, with remains of two registers offering-bringers with text between, on each, id. ib. pls. xvi [1], xv [1].

(12) and (13) South thickness, fragment of scene, north thickness, remains of three men, id. ib. pl. xv [3, 4].

Shrine.

(14) Remains of butchers, &c., id. ib. pl. xvi [2].

(15) and (16) Deceased, and three registers relations and retainers below, on either side of niche, id. ib. pls. xviii [1, 2], xxxvi [2].

(17) Three registers offering-bringers, id. ib. pl. xvii.

(18) Remains of offering-bringer, id. ib. pl. xv [2].

Niche.

(19)-(20) Lintel and jambs, id. ib. pl. xix; texts of jambs, CHASSINAT, op. cit. 75 [middle].

(21) Painted false door, BLACKMAN, op. cit. iii, pl. xx.

Entrance to Inner Hall.

(22)-(23) Lintel and jambs, with coloured decoration, id. ib. pls. ix, xxviii; texts of jambs, CHASSINAT, op. cit. 75 [bottom].

Inner Hall.

(24) Six registers, priests, offering-bringers and butchers (destroyed), BLACKMAN, op. cit. iii, pls. xxiii [2], xxiv [2].

(25) Offering-list and offerings, with remains of three registers offering-bringers and butchers below, id. ib. pls. xxvi-xxv, xxxii, xxxviii [2], xxxix.

(26)-(28) Deceased seated before offerings with wife below, false door, deceased before offerings, id. ib. pl. xxvii.

(29) Offering-list, and four registers, priests, butchers, and offering-bringers below, id. ib. pls. xxi-xxii.

(30) Five registers, men carrying trays of food, cooks, and offering-bringers, id. ib. pls. xxiii [1], xxiv [1], xxxi, xxxvii [3].

Group C.

C 1. UKH-ḤOTP $\frac{\text{𓆎}}{\text{𓆏}}$, Nomarch; Overseer of prophets; son of Ukh-ḥotp, and Ḥeny the middle. Temp. Sesostris II.

See BLACKMAN, *The Rock Tombs of Meir*, i, pp. 9, 12-13 [6], 17.



Hall.

(1) Deceased with family fishing; lower part, id. *Philological Notes in J.E.A.* xi, p. 213, fig. 1; titles of deceased, id. *The Rock Tombs of Meir*, i, p. 12 [6].

(2)-(3) Deceased with family fowling; titles of deceased, id. ib. p. 12 [6].

(4) Lower part, deceased in striped garment, id. ib. iii, pl. xxxv [2].

(5)-(6) Lower part, three registers, offering-bringers; bottom register, id. *The Archaeological Survey in Archaeological Report (1911-12)*, pl. viii [2] opposite p. 10, cf. p. 11.



ΚΗΑ'ΚΗΡΡΕ'—SONB , good name IY , Nomarch; Overseer of prophets. Dyn. XII. Close to last.

Coffins; texts, KAMAL, *Rapport sur les fouilles* [&c.] in *Ann. Serv.* xiv. 75-7. Plan, id. ib. p. 75, fig. 12.

Group D.

D 1. PEPI , Royal (?) scribe; Judge. Old Kingdom.

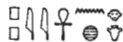
Titles, BLACKMAN, *The Rock Tombs of Meir*, i, p. 6, note 4.

D 2. PEPY-'ANKH-HIR-IB , also called NEFERKA , good name HENY , Nomarch; Vizier; Outline-draughtsman; Overseer of prophets of Hathor Mistress of Cusae; Overseer of Upper Egypt in the central nomes; &c. Temp. Pepy II.

Complete, BLACKMAN, op. cit. iv, passim, cf. i, pp. 6-7, 10 [3]; KAMAL, *Le tombeau nouveau de Mèir* in *Ann. Serv.* xv, pp. 209-58. Plan and sections, BLACKMAN, op. cit. iv, pls. i, ii; plan, KAMAL, op. cit. p. 211, fig. 1. Views, BLACKMAN, op. cit. iv, pls. xxii [1], xxiii [2]; id. *The Archaeological Survey* in *J.E.A.* i, pl. v [1] opposite p. 42.

Forecourt.

(1) Graffito, *ka*-servant with pot, and inspector of the *ka*-house, id. *The Rock Tombs of Meir*, iv, pl. iii [1 a, 1 b]; texts, KAMAL, op. cit. 210.

(2) and (3) Graffiti, steward followed by *ka*-servant, and two *ka*-servants with offerings, BLACKMAN, op. cit. iv, pl. iii [2, 3]; texts, KAMAL, op. cit. 210.

(4) and (5) Two scenes, deceased and wife with biographical text, BLACKMAN, op. cit. pls. iv, iv A [2, 3]; texts, KAMAL, op. cit. 212-13 [B], 214 [D, D'].

(4)-(5) Frieze; deceased and wife before offerings, deceased and wife, text with titles, and sacrificial animals, BLACKMAN, op. cit. pls. v [2], iv A [1], v [1]; texts, KAMAL, op. cit. 212 [A], 213 [C], 214 [C'].

Entrance to Outer Hall.

(6) and (7) Thicknesses; figure of deceased on each side, BLACKMAN, op. cit. pl. vi [1, 2]; texts, KAMAL, op. cit. 215.

Outer Hall.

(8) Deceased followed by four rows of officials watches four registers fowling with draw-net, preparing and bringing fowl, and netting fish, BLACKMAN, op. cit. pl. viii; texts, KAMAL, op. cit. 219-20.

(9)-(10) Deceased with family harpooning fish, and men in canoe above door, BLACKMAN, op. cit. pl. vii; texts, KAMAL, op. cit. 222.

(11) Deceased fowling followed by three rows of officials, BLACKMAN, op. cit. pl. xvii; texts, KAMAL, op. cit. 216 [upper].

(12) Top and second registers, bringing cattle, third register, two sailing and two rowing boats before deceased followed by four officials, BLACKMAN, op. cit. pls. xvi, xxvi [2]; texts, KAMAL, op. cit. 216-19; boats, id. ib. pp. 217-19, figs. 3-6.

(13) Deceased with steward in kiosk, with family and three registers wife's relations behind, receiving statement of accounts from officials, BLACKMAN, op. cit. pl. xv [left]; texts, KAMAL, op. cit. 223-5.

(14) Deceased with father and mother seated before tables, and two registers relations below, BLACKMAN, op. cit. pl. xv [right]; texts, KAMAL, op. cit. 225-6.

(15) Deceased in palanquin and wife below before table, with five registers male and female relations behind, watch five registers harvesting scenes, BLACKMAN, op. cit. pls. xiv [left], xxii [2], xxiii [1]; texts, KAMAL, op. cit. 226-8.

(16) Deceased watches six registers, goats browsing, cattle ploughing, &c., BLACKMAN, op. cit. pls. xiv [right], xxiv [1, 2], cf. xxiii [4 left]; texts, KAMAL, op. cit. 229-30; second register, group with calf, BLACKMAN, *The Archaeological Survey in J.E.A.* i, pl. v [2] opposite p. 42.

(17) Three registers, brewing and baking, id. *The Rock Tombs of Meir*, iv, pl. xiii; texts, KAMAL, op. cit. 231; third register, baking, id. ib. p. 231, fig. 8.

(18) Deceased and another man at table, with offering-list above, and row of offering-bringers and men with young animals below, BLACKMAN, op. cit. pl. xii, cf. xxiii [4, right]; texts, KAMAL, op. cit. 232-6.

(19)-(20) False door, and six registers of unguent vases beyond, BLACKMAN, op. cit. pls. xi, ix [left], xxvi [1]; texts, KAMAL, op. cit. 236-8.

(21)-(22) Deceased and wife at table with offering-list above, and four registers, offerings, bringing animals, musicians, draughts-players, butchers, and offering-bringers, BLACKMAN, op. cit. pls. ix [middle and right], x; texts, KAMAL, op. cit. 238-45; some offerings, and musicians and draughts-players, id. ib. pp. 242, 243, figs. 9, 10.

Sepulchral Chambers.

Hieratic inscriptions, BLACKMAN, op. cit. pl. xx.



South Chamber. Het-i'oh , wife of deceased.

Walls. Offering-list, granaries, house-façades, and offerings, id. ib. pls. xviii [1-3], xix [1], xxi [1], xxv [2]; texts, KAMAL, op. cit. 247-250.

North Chamber. Pepy'-ankh-hir-ib.

Walls. Painted house-façades and offerings, BLACKMAN, op. cit. pls. xviii [2], xix [2], xxi [2], xxiii [3]; texts, KAMAL, op. cit. 246.

Group E.

E 1. MENI  or Menia , Inspector of prophets; First under the King; Friend of the house of the royal favourites. Old Kingdom. (Rock-tomb.)

Hall.

Plan, KAMAL, op. cit. in *Ann. Serv.* xiii, p. 168, fig. 19. Titles, BLACKMAN, op. cit. i, p. 7, note 2. Texts from scenes, KAMAL, op. cit. 169-71.



Coffin of K̄edetnes , Prophetess of H̄athor, found near; text, id. ib. 171.

E 2. NENKI , Intimate; Lector. Old Kingdom.

Hall.

West wall. Deceased with titles, id. ib. 175; titles, BLACKMAN, op. cit. i, p. 7, note 3.

Sepulchral Chamber.

Coffin of Ptaḥshepses , good name Impy (?)  (?), Lector, Divine chancellor, found in tomb; texts, KAMAL, op. cit. 175.

Rock-drawing near tomb, oryx tied to altar, id. ib. p. 175, fig. 23.

E 3. PEPY'-ANKH  ♀ , Intimate; Lector. Temp. Pepy II (?).

Titles and name of wife, BLACKMAN, op. cit. i, p. 7, note 4.

E 4. THETU , Overseer of the *Thentet*-cows; First under the King; Inspector of prophets. Old Kingdom.

Hall.

West wall. Painted false door, KAMAL, op. cit. pp. 166-7, fig. 15; titles, BLACKMAN, op. cit. i, p. 7, note 5.

FAMILY-TOMB. Dyn. XII.













Plan, KAMAL, *Rapport sur les fouilles* [&c.] in *Ann. Serv.* xiv, p. 82, fig. 15.





Coffin of Hēpi-ankhtefi , Steward, found in one of the pits, now in New York, Metropolitan Mus.; texts, id. ib. 83-6.







MISCELLANEOUS







(From Meir, but exact provenance unknown.)

Coffins probably from north part of necropolis.



Gemit , Hen , Sennui , Khnemhotp , Ibt , Henu , Pedamenōpet , Ukh-hotp , Senbi , Sennu , Ukh-hotp  usurped from Senbi , Nakhta , and one without name; texts, KAMAL, *Rapport sur les fouilles* [&c.] in *Ann. Serv.* xi. 7-10, 26-7, 31-6, 39.

Khnemuhotp  (without lid), Khnemhotp , Senbi  (three coffins found together), and Hatheremhēt ; texts, id. ib. in *Ann. Serv.* xii. 104, 106-7, 119-27; second coffin of Senbi (probably), in Cleveland Mus., Ohio, RANSOM WILLIAMS, *The Egyptian Museum* [&c.] in *J.E.A.* v, pl. xxx [lower], cf. pp. 175-6.









'Ankhu , a commander of troops (name unknown), Ikui  good name Izi , Khenti  good name Ithat , a woman Nebt , and Hēneni ; texts, KAMAL, op. cit. in *Ann. Serv.* xiii. 164, 177.







Wahka , Thetu , Hatheremhēt , Khnemhotp  usurped by Hēneni , and Rerut ; texts, id. op. cit. in *Ann. Serv.* xiv. 45-56 [middle], 61-2.

Ameny , in New York, Metropolitan Mus., *A Handbook of the Egyptian Rooms* (1911), p. 59, fig. 26; texts of lid, KAMAL, op. cit. in *Ann. Serv.* xiv. 56 [bottom], cf. 57 [top].









Cartonnage and fragment of wood found in débris, including names of Meru  and a woman Hētep ; texts, id. op. cit. in *Ann. Serv.* xii. 115-17, 118.











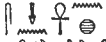

Coffins probably from south end of necropolis.

Meryib , Merery , Khnem'ankh  with headrest, Hēpi , Ukh  good name 'Aby , and a woman Sethut  good name Tetit  (three last found in tombs near tomb of Nēnki [E 2]); texts, id. op. cit. in *Ann. Serv.* xiii. 167-8, 172-4, 176-7 [top].

Hat , Imhōtep , Men  with mummy of Tunubaste , Graeco-Roman, 'Ankh-Hor  with mummy of a woman Dai'onkh , and Psheneḥe ; titles and texts, including some from Book of the Dead, id. op. cit. in *Ann. Serv.* xv, pp. 198-206, with figs. 4, 5.

Coffins in Cairo Museum, of which exact provenance is unknown.



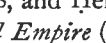

Wernüfer  No. 28037, Wersnüfer  (probably same as last) Nos. 28038-28039, Ukh-hotp  No. 28040, Senbi  No. 28041, . . . tseni  No. 28049, Istoḡer  No. 28052, Iḡer'ankh  No. 28053, Nakht  No. 28055,



Sen'ankh  No. 28057, Ukh-hotp  No. 28058, Sennui  No. 28060, Hēnyhirib  No. 28061, Hāthēhotp  No. 28062, Ukh-hotp  No. 28063, Ukh'a  No. 28064, Nebt  No. 28066, Ukh-hotp  No. 28067, Ukh-hotp  No. 28070, Titau  No. 28071, Hēnyhirib  No. 28075, Nefersab  No. 28078, and Hēnyhirib  No. 28079; texts, LACAU, *Sarcophages antérieurs au Nouvel Empire* (Cat. Caire), passim; of Nos. 28038–28039, BEAUVISAGE, *Recherches sur quelques bois pharaoniques* in *Rec. de Trav.* xviii. 90; transcription of cursive texts from interiors of Nos. 28040, 28041, DARESSY, *Notes et Remarques* in *Rec. de Trav.* xvi. 130–2; part of text of No. 28075, LACAU, *Textes religieux* in *Rec. de Trav.* xxvi. 228 [B].

Parts of coffin and mummy-mask of Iyni  Nos. 28068, 28073, id. *Sarcophages* [&c.] (Cat. Caire), pls. xvii, xxi, pp. 162, 165; texts of mask, DARESSY, *Notes et Remarques* in *Rec. de Trav.* xiv. 165–6; name and titles, CLÉDAT, *Notes archéologiques et philologiques* in *Bull. Inst. Fr. Arch. Or.* ii. 41 [I].

Fragments of coffins (names lost), Nos. 28042–8, 28050–1, 28054, 28056, 28059, 28065, 28069, 28072, 28081; texts, LACAU, *Sarcophages* [&c.] (Cat. Caire), passim. (See also Nos. 28077, 28080, 28082.)



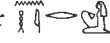







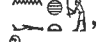

Fragment of coffin (no name), No. 28076; text, id. *Textes religieux* in *Rec. de Trav.* xxvi. 64–6 [B]; see id. *Sarcophages* [&c.] (Cat. Caire), p. 168.

Texts from fragments of coffins, including names of Khnemhotp , Khety , Ukh-hotp , Hēnib , and Iyni , CLÉDAT, op. cit. 41–3 [2–17].

Graeco-Roman mummies, coffins and cartonnage, including those of Nehir  and Bek (?) ; texts, KAMAL, op. cit. in *Ann. Serv.* xiv. 63–5, 66, 67, 78–81.

Graeco-Roman mummy-masks, in Cairo Mus. 33129–33135, EDGAR, *Graeco-Egyptian Coffins* (Cat. Caire), pls. viii–xvi, cf. pp. 18–31; texts of Nos. 33129, 33132, 33135, DARESSY, *Inscriptions hiéroglyphiques des masques de momie d'époque gréco-romaine* in *Ann. Serv.* xi. 44–6.

Statues.

Nakht , Overseer of the seal (four statues), Khnemhotp , woman Kayt , woman Sennu , Hēpkem , woman Hēteptu , woman Tept , two statues (names lost), Hā-ishutf , Steward, Int , Iuy , Steward, Iyni , woman . . . her . . . , woman Hēnyynu , Old Kingdom to Middle Kingdom, in Cairo Mus. 433–6, 437–42, 785–7, 789, 792–5, BORCHARDT, *Statuen und Statuetten* (Cat. Caire), vols. ii, iii.

Group of Ukh-hotp , Overseer of the prophets of Hāthor, with family, Middle Kingdom, in Cairo Mus. 459, id. ib. ii, pl. 76, pp. 51–2.

Uninscribed statues, Old Kingdom to Middle Kingdom, in Cairo Mus. 443–5, 453, 458, 788, 790, 791, 796, 797 (first, and last two, female), id. ib. vols. ii, iii.

Fragment of seated statue of Ukh-hotp , Commander of troops; texts, CLÉDAT, op. cit. in *Bull. Inst. Fr. Arch. Or.* i. 88–9.

Base of statue of Ukh-hotp , First under the King, Inspector of prophets, found in débris; texts, KAMAL, op. cit. in *Ann. Serv.* xiv. 82.

Stelae, &c.

Stela of Kay (?) , Door-keeper; text, id. ib. 86.

Fragments of stela of Khnemhotp , Overseer of immunities (?), son of Senbi, found at entrance to tomb near Tomb A 2; text, id. op. cit. in *Ann. Serv.* xii. 97–8.

Offering-table of Ukh-hotp , Nomarch, in Cairo Mus. 23026, id. *Tables d'Offrandes* (Cat. Caire), pl. xii, pp. 21–3.

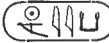

Ebony wand with names and titles of King Meryebrē' Khety, Dyn. IX, found in tomb at foot of mountain, id. *Un monument nouveau du pharaon Khatouï* in *Ann. Serv.* x. 185.

Inscribed copper brazier of King Meryebrē' Khety, in Louvre; text round rim, MASPERO, *Hist. Anc. des Peuples de l'Orient, Les Origines*, fig. on p. 448; PETRIE, *A History of Egypt*, i (1923), p. 132, fig. 85; text, MASPERO, *Notes au Jour le Jour* in *P.S.B.A.* xiii. 429 [10]; GAUTHIER, *Le Livre des Rois*, i. 204 [1].

Wooden palette of King Merkarē' , Dyn. X, found with last, now in Louvre; upper part, MASPERO, *Hist. Anc. des Peuples de l'Orient, Les Origines*, fig. on p. 458; PETRIE, op. cit. p. 133, fig. 86; cartouche, MASPERO, op. cit. in *P.S.B.A.* xiii. 430; GAUTHIER, op. cit. i. 209 [ii].

Canopic jars, Dyn. XI–XII, in Cairo Mus., REISNER, *The Dated Canopic Jars of the Gizeh Museum* in *A.Z.* xxxvii, p. 62, fig. 1 [b, c], cf. p. 61.

Fragments of canopic jars of Mesti , Dyn. XII; name, KAMAL, op. cit. in *Ann. Serv.* xiv. 87.

Ostracon of Ukh-hotp , son of Ukh-hotp, and part of stela and inscribed cartouche of Senbi , Steward; texts, KAMAL, op. cit. in *Ann. Serv.* xi. 36–8.

Inscribed model-boat with name of 'Anti (?) , in Cairo Mus. 4847, REISNER, *Models of Ships and Boats* (Cat. Caire), pl. ix, pp. 34–7.

EL-QÛŞÏYA (CUSAE)



Block engraved with cartouches of Ptolemy I Soter I between Ḥathor-heads, probably from here, GRIFFITH, *Excavations at El-Amarnah, 1923–4* in *J.E.A.* x, pl. xxxvii [3], cf. p. 305.

Fragment of lintel, found in village; remains of text, CLÉDAT, op. cit. in *Bull. Inst. Fr. Arch. Or.* i. 90 [top].

SITES SOUTH OF MEIR

EL-TATÂLÏYA

NECROPOLIS. Graeco-Roman.

Coffins of Tede , daughter of Dḥutef'onkh , and her son Seshep-Min , Graeco-Roman; texts, KAMAL, *Rapport sur les fouilles* [&c.] in *Ann. Serv.* xv. 195–8.

DARA, west of Manfalût.





BRICK PYRAMID OF KING KHUI . Dyn. VI.

Plan and section, KAMAL, *Fouilles à Dara et à Qoçêir el-Amarna* in *Ann. Serv.* xii, pp. 128–9, figs. 1, 2.





Re-used blocks, &c.

Stela of Asekhu , Overseer of the garden of the Great House, id. ib. p. 131, fig. 6.

Stela of Ḥefni , Great steward, Overseer of the garden; text on left jamb, id. ib. 130 [bottom left].

Offering-tables of Khui , Prophetess of Ḥathor, Khai , Overseer of linen (?), Ḥai , Chancellor of the King of Lower Egypt, Ḥentni-Khnum , Prophetess of Ḥathor, and Khui , Chancellor of the King of Lower Egypt, id. ib. pp. 129–30, 132, figs. 3–5, 7–8.

MASTABA SOUTH OF PYRAMID.

Piece of wood with name of Khui , Chief lector, fragment of bas-relief with cartouche of King Khui , and fragments of coffin of Ḥa . . nyg . . ka . . 
, Overseer of prophets and lectors (?); texts, id. ib. p. 132 with fig. 9, and p. 133.



TOMB WEST OF PYRAMID.

Offering-list on wall, id. ib. 134.

EL-^cATÂMNA

ROCK-TOMBS. Old Kingdom.

Stela of User , Intimate, Lector, in Asyût Mus.; text, KAMAL, op. cit. in *Ann. Serv.* xv. 186.

Coffin of Senbi , good name Baḳt , Intimate; texts, id. ib. 187-9.

Block with offering-text of Khui , Intimate, Lector, in Asyût Mus.; texts, id. ib. 190.

MASRA^c

NECROPOLIS.

Fragments of coffin of Imḥōtep , Dyn. XII; texts, KAMAL, op. cit. in *Ann. Serv.* xi. 6-7.

MANQABÂD

DESTROYED TEMPLE (?).

Block of Amenophis IV; cartouches, id. ib. 3.

NECROPOLIS. Graeco-Roman. North-west of ancient town.

Fragments from tombs, including ushabti with name of Nebiri , First prophet of Merymutf lord of Kha'y; texts, id. ib. 3-4.

XII. ASYÛṬ AND DEIR DURUNKA

ASYÛṬ (LYCOPOLIS)

TEMPLE 

Amenophis IV usurped by Ramesses II.

Blocks with Aten-cartouches, names of Amenophis IV and Nefertiti, and relief of woman kissing King's hand, found re-used beneath house in Asyût, GABRA, *Un Temple d'Amenophis IV à Assiout* in *Chronique d'Égypte*, July 1931, pp. 237-43 with figs. 1-5.

Blocks of Ramesses II, id. ib. p. 242 [bottom] and fig. 6.

NECROPOLIS

Rock-tombs.¹ Middle Kingdom.

GRIFFITH, *The Inscriptions of Siût and Dér Rîfeh*, passim; MONTET, *Les Tombeaux de Siout et de Deir Rifeh* in *Kémi*, i, pp. 53-68, pls. iii-vi (to be continued in future numbers). General view, *Descr. de l'Égypte, Ant.* iv, pl. 43, cf. *Texte*, iv, pp. 133-53; HAY*, 29814, 75. Description, HAY*, 29857, 15-25 [upper]; BONOMI MSS.* Diary, Jan. 21, 1825, April 29, 1826; SAINT-FERRIOL MSS.* Diary, Jan. 31, 1842. (For bibliography, see GRIFFITH, *The Inscriptions of Siût and Dér Rîfeh* in *Babylonian and Oriental Record*, iii. 244-52.)

¹ The marginal tomb-numbers are those of GRIFFITH.

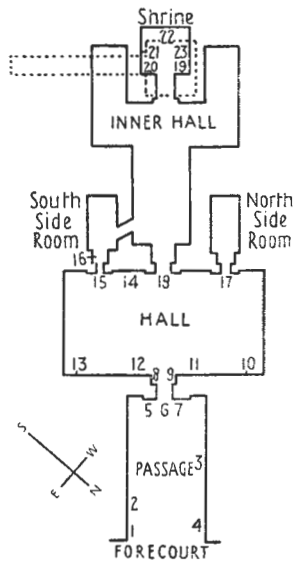

Asyût. Tomb 1. Hepzefa I.
From *Descr. de l'Égypte, Ant.*
iv, pl. 44 [1].

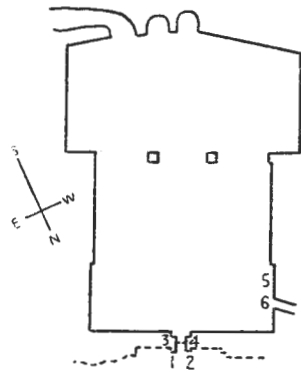

Asyût. Tomb 3. Tef-ibi. From
Descr. de l'Égypte, Ant. iv,
pl. 48 [9].

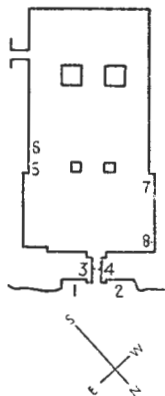

Asyût. Tomb 4. Khety II.

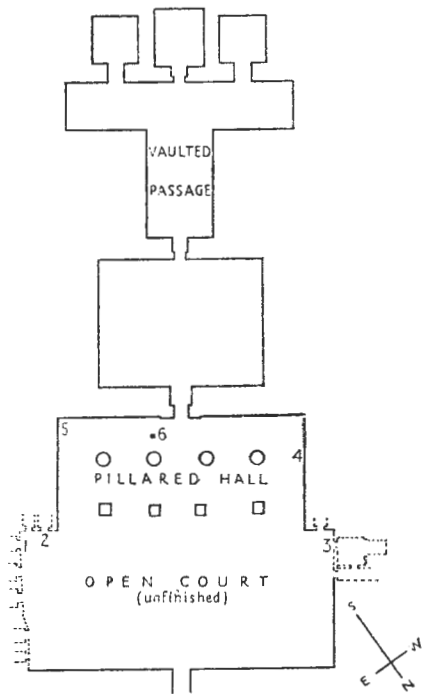

Asyût. Hepzefa III ('Salkhana Tomb'). From
plan supplied by DR. STECKEWEH, who is
not responsible for the dotted part, represent-
ing later subsidiary tombs, of which the
details are only approximately correct.

- I. HEPZEFA I ⲭⲓⲛⲓⲛⲓ, Nomarch of the Lycopolite nome; Chancellor of the King of Lower Egypt; Overseer of the prophets of Wepwaut lord of Siût; &c. Temp. Sesostris I. Called 'Iṣtabl 'Antar.'

(1 of LEPSIUS.)

GRIFFITH, *The Inscriptions of Siût and Dér Rifeh*, pls. 1-10 [right], 20 [bottom middle]; see REISNER, *The Tomb of Hepzefa, Nomarch of Siût* in *J.E.A.* v. 79-98. Plan, sections, and elevation, *Descr. de l'Égypte, Ant.* iv, pl. 44; MONTET, op. cit. pl. iii [1-4] (from *Descr.*); HAY*, 29814, 94, 94 verso, 95 verso; plan, DENON, *Voyage* (1802), pl. 33 [bottom]; REISNER, op. cit. 80; see GRIFFITH, op. cit. pl. 3 [bottom right].

Forecourt (destroyed).

View of entrance (destroyed) to Passage, *Descr. de l'Égypte, Ant.* iv, pl. 44 [2]; DENON, op. cit. pl. 33 [2]; HAMILTON, *Aegyptiaca*, xix [3]; see MONTET, op. cit. pl. iii [5].

Passage.

(1)-(2) Funerary spells, GRIFFITH, op. cit. pl. 9, ll. 370-3.

(3)-(4) Funerary spells, id. ib. pls. 9-10, ll. 380-417.

Entrance to Hall.

(5)-(7) Lintel and jambs. id. ib. pl. 9, ll. 345-59; jambs, WILKINSON MSS.* v. 30 [left], 32 [middle right]; left jamb, NESTOR L'HÔTE MSS.* 20396, 140 [left]; titles, DE ROUGÉ, *Inscr. Hiéro.* cclxxxv [lower]; titles of deceased with name of mother [GRIFFITH, l. 351], WILKINSON MSS.* v. 32 [top], x. 49 [bottom]; BRUGSCH, *Thes.* 1513 [d]; names, *L. D. Text*, ii, p. 154 [middle].

(8) Thickness, deceased with staff and mace, and text above, *Descr. de l'Égypte, Ant.* iv, pl. 47 [11]; HAY*, 29847, 18, 68 [top right]; texts, GRIFFITH, op. cit. pl. 9, ll. 330-6, pl. 20, ll. 330-6; ll. 330-1, WILKINSON MSS.* v. 30 [right]; DE ROUGÉ, *Inscr. Hiéro.* cclxxxiv [right] (incomplete).

(9) Thickness; text above deceased, GRIFFITH, op. cit. pl. 9, ll. 337-42.

Hall.

(10)-(11) Text of contracts with introductions, id. ib. pls. 6-8, ll. 260-324; DE ROUGÉ, op. cit. cclxxi-cclxxxiv [left], cclxxxv [upper]; MARIETTE, *Mon. Div.* pls. 64-7; HAY*, 29847, 71-4; omitting titles, ERMAN, *Zehn Verträge aus dem mittleren Reich* in *Ä.Z.* xx. 166-83; names of festivals, BRUGSCH, *Thes.* 237, 362 [upper right]; some names of festivals, id. *Recueil*, xi [2, 3]; see NESTOR L'HÔTE MSS.* 20396, 140 verso [lower].

(12)-(13) Scene of deceased adoring cartouches of Sesostris I, and text including address to visitors, GRIFFITH, op. cit. pls. 4-5, ll. 210-49; HAY*, 29847, 69-70; cartouches, MONTET, op. cit. p. 67 [lower].

(14) Two bottom registers, offering-bringers; texts, id. ib. p. 65 [lower].

Entrance to South Side-room.

(15) Remains of text on lintel, GRIFFITH, op. cit. pl. 3, ll. 160-3; MONTET, op. cit. p. 66 [top].

(16) Thickness, deceased standing; text [cf. GRIFFITH, pl. 3, ll. 170-4], MONTET, op. cit. p. 66 [middle].

Entrance to North Side-room.

(17) Lintel, GRIFFITH, op. cit. pl. 3, ll. 180-5; text, MONTET, op. cit. pp. 66-7.

Entrance to Inner Hall.

(18) Lintel, and top of right jamb, GRIFFITH, op. cit. pl. 3, ll. 150-5; text, MONTET, op. cit. pp. 64 [lower]-65 [upper].

Shrine (jambs and thicknesses destroyed).

(19) and (20) Preparing oxen for sacrifice (destroyed), *Descr. de l'Égypte, Ant.* iv, pl. 45 [1-8]; see GRIFFITH, *op. cit.* pl. 2 [bottom]; texts, MONTET, *op. cit.* pp. 62-4; one scene of butchers [3 of *Descr.*], CAILLAUD, *Arts et Métiers*, pl. 19; see GRIFFITH, *op. cit.* in *Babylonian and Oriental Record*, iii. 247-8.

(21) Offering-list and three registers offering-bringers, before deceased; omitting deceased, GRIFFITH, *The Inscriptions of Sîût and Dér Rîfeh*, pls. 1, ll. 25-54, and 2, ll. 55-64; MONTET, *op. cit.* pp. 56-9, cf. pls. iv, vi [2]; titles of deceased, MARIETTE, *Mon. Div.* pl. 68 [b].

(22) Offering-text, and deceased with mother, daughter, and two wives below; figures, WILKINSON MSS.* x. 54; texts, GRIFFITH, *op. cit.* pl. 1, ll. 1-15; MONTET, *op. cit.* p. 55. Remains of false door at lower level, GRIFFITH, *op. cit.* pl. 1, ll. 13-15.

(23) Offering-list, deceased before offerings, and three registers offering-bringers, GRIFFITH, *op. cit.* pls. 2, ll. 100-24, and 3, ll. 85-99; MONTET, *op. cit.* pp. 59-62, cf. pls. v, vi [1]; titles, MARIETTE, *Mon. Div.* pl. 68 [a]; title of priest from bottom register, BRUGSCH, *Thes.* 1513 [e].

Ceiling. Decoration, WILKINSON, *M. and C.* ed. BIRCH, i, pl. viii [4, 6, 7] opposite p. 363; WILKINSON MSS.* v. 31.

For another tomb of deceased, at Kerma, Nubia, see later volume of *Bibl.*

Subsidiary Tomb.

ḤENY , Steward. Dyn. XI (?). At entrance to tomb of Ḥepzefa I.

See WAINWRIGHT, *A subsidiary Burial in Ḥap-Zefi's tomb at Assiut* in *Ann. Serv.* xxvi. 160-6. Plan and section, GUNN, *The Coffins of Ḥeny* in *ib.* 171 [lower right].

Fragments of coffins; texts, *id. ib.* 166-70, 171 [left].

Statuette of deceased, WAINWRIGHT, *op. cit.* pp. 161, 171 [top right].

2. ḤEPZEFA II , Nomarch of the Lycopolite nome; Chancellor of the King of Lower Egypt; Intimate; Overseer of prophets of Osiris and of Wepwaut. Dyn. XII. (5 of LEPSIUS.) (Destroyed.)

GRIFFITH, *op. cit.* pls. 10 [left], 20 [bottom left]. Plan, *Descr. de l'Égypte, Ant.* iv, pl. 47 [2].

Façade.

Exterior of entrance, lintel and jambs with deceased on left side, *Descr. de l'Égypte, Ant.* iv, pls. 46 [10], 47 [1], 49 [5]; HAY*, 29847, 68 [top left]; texts, GRIFFITH, *op. cit.* pl. 20 [bottom left]; deceased and left jamb, HAY*, 29814, 87; left jamb, BRUGSCH, *Thes.* 1512 [b]; *L. D. Text*, ii, p. 156 γ; NESTOR L'HÔTE MSS.* 20396, 140 [right].

Entrance.

South thickness, GRIFFITH, *op. cit.* pl. 10, ll. 3-10; deceased and text, *Descr. de l'Égypte, Ant.* iv, pl. 47 [10]; text, DE ROUGÉ, *Inscr. Hiéro.* cclxxxvii; MARIETTE, *Mon. Div.* pl. 68 [c]; BRUGSCH, *Thes.* 1512 [a]; first line, *L. D. Text*, ii, p. 156 a.

North thickness, GRIFFITH, *op. cit.* pl. 10, ll. 11-18; text, DE ROUGÉ, *op. cit.* cclxxxvi; part, BRUGSCH, *Thes.* 1512 [c]; one line, *id. Recueil*, xi [1]; incomplete, *L. D. Text*, ii, p. 156 β; WILKINSON MSS.* x. 52 [right].

Remains of titles above inner doorway, GRIFFITH, *op. cit.* pl. 10, ll. 1, 2.

3. TEF-IBI , Nomarch of the Lycopolite nome; Chancellor of the King of Lower Egypt; Intimate; Overseer of prophets of Wepwaut. Dyn. IX-X. (4 of LEPSIUS.)

GRIFFITH, op. cit. pls. 11-12. Plan, *Descr. de l'Égypte, Ant.* iv, pl. 48 [9]; HAY*, 29814, 17 verso.

Entrance.

(1)-(2) Lintel and jambs (destroyed), texts and figures of Isis suckling Horus at bottom; omitting figures, GRIFFITH, op. cit. pl. 12, ll. 65-71; *Descr. de l'Égypte, Ant.* iv, pl. 48 [11], cf. *Texte*, iv, pp. 142-3.

(3) and (4) Thicknesses (destroyed), deceased and text, *Descr. de l'Égypte, Ant.* iv, pl. 49 [8, 9]; text, GRIFFITH, op. cit. pl. 12, ll. 57-64.

Hall.

(5)-(6) Address to visitors and original (engraved) biographical text, GRIFFITH, op. cit. pls. 11-12, ll. 1-40; BRUGSCH, *Thes.* 1507-11; ll. 1-19, DE ROUGÉ, *Inscr. Hiéro.* ccxc-ccxcii; ll. 41-56 of substituted (painted) text, GRIFFITH, op. cit. pl. 12 [bottom right], cf. p. 11; substituted fragment on stucco at end of l. 1, *L. D. Text*, ii, p. 156 [top]; see GRIFFITH, op. cit. in *Babylonian and Oriental Record*, iii. 128.

4. KHETY II , Nomarch of the Lycopolite nome; Chancellor of the King of Lower Egypt; Intimate; Overseer of prophets of Wepwaut. Temp. Merkaré, Dyn. X. (3 of LEPSIUS.) Immediately north of Tomb No. 3.

GRIFFITH, *The Inscriptions of Siût and Dér Rifeh*, pls. 13, 14, 20 [upper]. Description, HAY*, 29814, 18. Plan and section, *Descr. de l'Égypte, Ant.* iv, pls. 46 [1] (or 48 [3]), 46 [3].

Façade (destroyed).

(1)-(2) Lintel and jambs with deceased standing on either side, *Descr. de l'Égypte, Ant.* iv, pls. 46 [2, 5], 48 [4, 5], cf. *Texte*, iv, pp. 145-8; texts, GRIFFITH, op. cit. pl. 14, ll. 61-5, 76, 77.

Entrance.

(3) and (4) Thicknesses; deceased with text on either side (destroyed), *Descr. de l'Égypte, Ant.* iv, pl. 49 [1, 3]; texts, GRIFFITH, op. cit. pl. 14, ll. 45-60; part of text of south side [ll. 50-2], WILKINSON MSS.* vii. 38 [bottom right].

Hall.

(5)-(6) Three registers soldiers, WRESZINSKI, *Atlas*, ii. 15; MEYER, *Darstellungen der Fremdvölker*, 79, 80; four soldiers, CHAMPOLLION, *Mon.* cccxlix quat. [4]; ROSELLINI, *Mon. Civ.* cxvii [4]; MASPERO, *Hist. Anc. des Peuples de l'Orient, Les Origines*, fig. on p. 457; HAY*, 29814, 92-3; two soldiers, *Descr. de l'Égypte, Ant.* iv, pl. 46 [4]; one soldier, WILKINSON, *M. and C.* i. 303 (No. 24) = ed. BIRCH, i. 202 (No. 29); BRUGSCH, *Thes.* 1503 (called east wall); WILKINSON MSS.* vii. 39 [top right].

(7)-(8) Deceased and wife and biographical text, *Descr. de l'Égypte, Ant.* iv, pl. 49 [2, 4]; BRUGSCH, *Thes.* 1503-6 [c]; HAY*, 29814, 90, 29847, 17, 75; omitting deceased and wife, GRIFFITH, op. cit. pl. 13, ll. 1-40, cf. pl. 20 [upper]; MARIETTE, *Mon. Div.* pl. 69 [a, b]; ll. 26-34, DE ROUGÉ, *Inscr. Hiéro.* ccxciii; ll. 19, 21-3, and texts of deceased and wife, *L. D.* ii. 150 g, h, i, and *Text*, ii, p. 155 [lower] with α, β ; ll. 21, 22, WILKINSON MSS.* x. 52 [lower left]; titles above them, id. ib. vii. 39 [top left], x. 53 [top].

Pillars.

Remains of texts, GRIFFITH, *op. cit.* pl. 14 [bottom middle].

Deceased seated before offerings, probably from this tomb, *Descr. de l'Égypte, Ant.* iv, pl. 49 [10], cf. *Texte*, iv, p. 142. Two fragments from top of a wall, perhaps from this tomb, GRIFFITH, *op. cit.* pl. 13, ll. 41-4; *Descr. de l'Égypte, Ant.* iv, pl. 47 [12, 13].

5. KHETY I , Nomarch of the Lycopolite nome; Chancellor of the King of Lower Egypt; Intimate; Overseer of prophets of Wepwaut and Anubis. Dyn. IX-X. (2 of LEPSIUS; 3 of MARIETTE.) (Roofless.) Immediately north of Tomb No. 4.

GRIFFITH, *op. cit.* pl. 15. Plan and section, *Descr. de l'Égypte, Ant.* iv, pl. 47 [8, 9].

Entrance.

Thicknesses (destroyed), figures of deceased with oryx and gazelle below, *Descr. de l'Égypte, Ant.* iv, pl. 49 [6, 7]; texts, GRIFFITH, *op. cit.* pl. 15, ll. 41-8; deceased and part of texts of left thickness, WILKINSON MSS.* vii. 38 [top].

Hall.



West wall, false door, GRIFFITH, *op. cit.* pl. 15, ll. 1-24; biographical text, BRUGSCH, *Thes.* 1499-1502 [a]; omitting top, MARIETTE, *Mon. Div.* pl. 68 [d]; DE ROUGÉ, *Inscr. Hiéro.* cclxxxviii, cclxxxix; parts, L. *D. Text*, ii, p. 155 [upper left].

South wall, biographical text, GRIFFITH, *op. cit.* pl. 15, ll. 25-40; BRUGSCH, *Thes.* 1502 [b].

ḤEPZEFA III , Nomarch of the Lycopolite nome; Hereditary prince; Overseer of prophets. Temp. Amenemḥēt II. At foot of hill behind slaughter-house ('salkhana'). (See plan, *supra* p. 260.)

See Moss, *An Unpublished Rock-tomb at Asyûṭ* in *J.E.A.* xix. 33.

Open Court.

(1), (2), (3) Entrances to subsidiary tombs of Wepu , Overseer of sealers, Idi , Lector and Prophet, and Ḥepzefa , Overseer of sealers; names, *id. ib.* 33 [bottom].

Pillared Hall.



(4) Texts including contract, see *id. ib.* 33 [middle].

(5) Hoard of stelae, New Kingdom, found in 1922 leaning against south-east wall, now in Cairo Mus.; upper part of one stela with emblem of Amūn between Min and Rē, and part of top of another stela with Amen-Rē Kamutef as bull, WAINWRIGHT, *The Aniconic Form of Amon in the New Kingdom* in *Ann. Serv.* xxviii, p. 176, fig. 1, p. 182, fig. 6.

(6) Demotic papyri found at same time, see SOTTAS, *Sur quelques papyrus démotiques provenant d'Assiout* in *Ann. Serv.* xxiii. 34-46.

DESTROYED TOMB. North of Tomb of Khety II.

Jambs and thicknesses; texts, PALANQUE, *Notes de fouilles dans la nécropole d'Assiout* in *Bull. Inst. Fr. Arch. Or.* iii. 120-1 [i].

MESEHTI  —  =, Mayor; Chancellor of the King of Lower Egypt; Lector; Overseer of prophets. Dyn. IX or X.





Coffins with texts of Book of the Dead, in Cairo Mus. 28118, 28119, LACAU, *Sarcophages antérieurs au Nouvel Empire* (Cat. Caire), ii, pl. ix, pp. 101-33; texts of inner coffin, No. 28118, id. *Textes religieux* in *Rec. de Trav.* xxvi. 64-6 [A], 73-80 [D], 227-8 [A], 232-6, xxvii. 53-61 [A, B], 53-4 [C], 217-21, xxx. 194-202 [A], 199-202 [B], xxxi. 10-11 [A, B], 12-17 [B], 12-33 [A], 161-75; list of deccans on centre, and horizontal text between, DARESSY, *Une ancienne liste des dékans égyptiens* in *Ann. Serv.* i. 83-8, 80.

Alabaster statue, in Cairo Mus. 235, BORCHARDT, *Statuen und Statuetten* (Cat. Caire), i, pl. 49, cf. p. 154; EVERS, *Staat aus dem Stein*, i, pl. 2.

Base of statue of deceased, in London, University Coll.; text, WEIGALL, *Some Inscriptions in Professor Petrie's Collection of Egyptian Antiquities* in *Rec. de Trav.* xxix. 216.

Two wooden groups of foreign soldiers, in Cairo Mus. 257-8, GRÉBAUT, *Le Musée Égyptien*, i. xxxiii-xxxv; MASPERO, *Hist. Anc. des Peuples de l'Orient, les Premières Mêlées*, fig. on p. 223; MEYER, *Darstellungen der Fremdvölker*, 28-9, 245-9; STEINDORFF, *Die Blütezeit des Pharaonenreichs* (1900), p. 53, Abb. 46; (1926), p. 53, Abb. 47; one group, BLACKMAN in ROSS, *The Art of Egypt through the Ages*, p. 140 [3]; four soldiers from each group, BORCHARDT, op. cit. i, pls. 55-6, cf. pp. 164-5; see WOLF, *Die Bewaffnung des Altägyptischen Heeres*, pl. 20.

Wooden beam with titles of deceased, in Berlin Mus. 13530; text, *Aeg. Inschr. Mus. Berlin*, i. 251; see *Ausführ. Verzeichnis* (1899), p. 105.



Model boat with inscribed cabin-door, from tomb of Mesehti  —  (or  — ), Hereditary prince, Overseer of the prophets of Wepwaut, presumably the same man, found in 1875, now in Cairo Mus. 4918, GRÉBAUT, *Le Musée Égyptien*, i, pl. xxxvii, cf. pp. 34-6; REISNER, *Model Ships and Boats* (Cat. Caire), pl. xviii, pp. 74-80, figs. 277-300.

Tombs at top of hill, north end.





Re-used in Saite, Ptolemaic, and Graeco-Roman Periods.

DESTROYED TOMB.

Remains of text and list of offerings, PALANQUE, op. cit. in *Bull. Inst. Fr. Arch. Or.* iii. 122 [ii].

Fragments from destroyed tombs, one with name of Hori  , and some of New Kingdom (?) period, id. ib. 123-5 [iii-v].

FOUND IN DÉBRIS OF LATER CEMETERY.

Coffin of Wepwautemhêt  —    , in Louvre E. 12035, CHASSINAT and PALANQUE, *Une Campagne de fouilles dans la nécropole d'Assiout* in *Mém. Inst. Fr. Arch. Or.* xxiv, pls. xxxvii-xxxix, pp. 228-33.

Coffin of Hēpzefa     , id. ib. pl. xl, pp. 233-6.

Tombs below Tomb of Khety II. Dyn. IX-XII.¹

View of part of site, id. ib. pl. i. See CHASSINAT in *Archaeological Report* (1903-4), pp. 33-4.









¹ The marginal tomb-numbers are those of CHASSINAT and PALANQUE.

6 FAMILY TOMB.

Hall.

Statuette of Idu , found in débris, CHASSINAT and PALANQUE, op. cit. pl. ii [1], p. 5.

Sepulchral Chambers.

Coffins of Nakht  (usurped from 'Ankhef ) , dwarf 'Ankhef  (usurped from Khetu ) , Kheti , By , Idu , Nakht , and 'Ankhef  ; texts, id. ib. pp. 7-27.

Mummy-mask of Nakht, id. ib. pl. iii [1].

7. NAKHTI , Overseer of the seal.

See id. ib. pp. 29-154, pls. iv-xxviii.

Hall.

North wall. Wooden statue of Nakht , in Cairo Mus., id. ib. pl. v, p. 31 ; CAPART, *Some Remarks on the Sheikh El-Beled* in *J.E.A.* vi, pl. xxiv [upper left] opposite p. 226.

West wall. Wooden statue of deceased, in Louvre E. 11937, CHASSINAT and PALANQUE, op. cit. pls. vi, vii, p. 32 ; BOREUX, *Guide-Catalogue Sommaire*, i (1932), pl. xvi, cf. p. 142 ; CAPART, op. cit. pl. xxiv [upper right].



Statuette of Henen , and statuettes of female offering-bringers, CHASSINAT and PALANQUE, op. cit. pls. viii, iv, ix, x, p. 30, fig. 2, cf. pp. 33-4 ; two offering-bringers [= ix, x of CHASSINAT and PALANQUE], in Cairo Mus., CAPART, *L'Art Égyptien* (1909), pl. 42 ; one offering-bringer [= iv of CHASSINAT and PALANQUE], in Louvre E. 12029, BOREUX, op. cit. i, pl. xxii, cf. p. 177.

Sepulchral Chambers.**Pit 1.**



Coffins with texts of Book of the Dead, in Louvre E. 11936, and mummy-mask, of deceased, CHASSINAT and PALANQUE, op. cit. pls. xvi-xx, xxi [1], iii [2], pp. 35-46, 53-110 with fig. 4 ; see BOREUX, op. cit. i, p. 166.

Statuettes, votive arms, model boats and work-shops, CHASSINAT and PALANQUE, op. cit. pls. xi-xv [1, 2], cf. pp. 47-52 with fig. 3 ; two statuettes, CAPART, op. cit. in *J.E.A.* vi, pl. xxiv [lower] ; one statuette, and model butchers, in Boston Mus., *The Exhibition of Recent Acquisitions of the Egyptian Department in Boston Mus. Bull.* iii, April 1905, p. 14 [upper left, and lower] ; one boat [= xiv (2) of CHASSINAT and PALANQUE], in Louvre, BOREUX, op. cit. i, pl. xxiii [lower], cf. p. 181.



Pit 2.

Coffins of Ma'et  and Itef-ib  ; texts, CHASSINAT and PALANQUE, op. cit. pp. 114-22, 123-4.

Pit 3.



Coffin, in Louvre E. 12036, and mummy-mask of Khetety , usurped from Khuni-'Anti (?) , id. ib. pls. xxiv-xxvii [1, 2], pp. 125-34 ; see BOREUX, op. cit. i, p. 166.

Pit 4.

Coffin of Nakht  or , Overseer of the seal, of the gate (or Judgement-hall), and of boats ; texts, CHASSINAT and PALANQUE, op. cit. pp. 135-42.

Coffin of Henen , in Louvre, id. ib. pl. xxviii, pp. 143-54.

Female statuette, id. ib. pl. xxvii [3].

8. KHU  and WEPWAUT-NAKHTI .

Coffin of Khu; one side, deceased leading dog, id. ib. pl. xxix [lower]; texts, id. ib. pp. 156-7.

Coffin of Wepwaut-nakhti; texts, id. ib. pp. 158-9.

13. NAME UNKNOWN.

Female statuette, in Louvre, id. ib. pls. xxxi [2], xxxii, cf. p. 162.

14. WEPWAUTEMHËT .

Hall.

Statue, model beer-makers, boat, and statuettes, found in position, id. ib. pls. xxxiv-xxxv; statue of deceased and female offering-bringer, in Boston Mus., *The Exhibition of Recent Acquisitions* [&c.] in *Boston Mus. Bull.* iii, April 1905, pp. 15, 14 [upper right]; *Handbook* (1920), p. 37.

Coffin; texts, CHASSINAT and PALANQUE, op. cit. pp. 164-6.













20. 'ANKHEF  and TEF-IBI .

Statue-chamber.

Statue of 'Ankhef, female offering-bringers, statuettes, &c.; statue, id. ib. pl. xxxvi, cf. pp. 188-9.

Coffins; texts, including Book of the Dead, id. ib. pp. 189-213.

VARIOUS.

Coffins of Sisobk  (Tomb 15), Tai  and wife (Tomb 16), Zeh , 'Anu , and Wepay  (all three Tomb 17), Hepzefi  and 'Anu  (both Tomb 18), Her . . . , Dega , and another with name effaced (all three Tomb 19), Mesehti  and Heny  (both Tomb 23), and Dednu  and Heny  (both Tomb 26); texts, id. ib. pp. 167-87, 218-25, cf. pls. xxix [lower], xxx [lower].



MISCELLANEOUS



(From Asyût, but exact provenance unknown.)

Wall-fragments and stelae.

Figures in high relief, Old Kingdom, apparently from a destroyed tomb, *Descr. de l'Égypte, Ant.* iv, pl. 46 [9].



Fragment of wall, three figures of Iam-Ptah , in Cairo Mus. 20769; texts, LANGE and SCHÄFER, *Grab- und Denksteine des Mittleren Reichs* (Cat. Caire), ii, p. 400.



Painted stela of Wepay  and Khety , Dyn. XII, in Brit. Mus. 928, *Hiero. Texts* [&c.], Pt. iv, pl. 30; see *Guide, Sculpture* (1909), p. 76 [257].

Stela of M'asen (?)  (?) and coffin of Itef-ibi , Kitchen-master; names, KAMAL, *Fouilles* [&c.] in *Ann. Serv.* xvi. 112 [1540], 113 [1580].









Fragment of stela with cartouches of Ramesses III, in Collection Saïd Bey Khachaba; cartouches, KAMAL, *Fouilles à Dara et à Qoçéir el-Amarna* in *Ann. Serv.* xii. 135 [10].







Coffins.







Ini  and Sentuser , Unique royal ornament, Prophetess of Hathor, usurped by Ipi , Ruler of the Residence, &c., Middle Kingdom, in Cairo Mus.; texts, LEFEBVRE, *À travers la Moyenne-Égypte* in *Ann. Serv.* xii. 91-2, xiii. 10-18.







Henui  and Hētep , Middle Kingdom, in Brussels, Musées Royaux du Cinquantenaire, E. 3035, E. 3036; texts, SPELEERS, *Rec. des Inscr. Ég.* 19-21 [83, 84]; of Hētep, CAPART, *Donation d'antiquités égyptiennes*, figs. 16, 17, cf. pp. 37-41.

Heny , Middle Kingdom, in Brit. Mus. 29576, *Guide to the First and Second Egyptian Rooms* (1904), pl. iii opposite p. 56; *Guide to the First, Second and Third Egyptian Rooms* (1924), pl. xi after p. 80.

Wepwautemhēt , in Minya Mus. 275, Shebwi , Dyn. XII, Weputemhēt , in Minya Mus. 278, 'Ankhef , Hēpzefai  (found south of tomb of Hēpzefa I), Hēnten , Thauau , Shems , and Thauau ; texts, KAMAL, *Fouilles à Deir Dronka et à Assiout in Ann. Serv.* xvi. 100-11, 113-14 [125°, 130°, 131°, 134°, 138°, 142°-4°, 161°]; of Wepwautemhēt and Weputemhēt, GAUTHIER and LEFEBVRE, *Sarcophages du Moyen Empire* [&c.] in *Ann. Serv.* xxiii. 8-9, 12-13.

Woman Wepwautemhēt , Mesehti , 'Ankhef , Thoy , in Minya Mus. 272, 273, 276, 277, and Nakhti  (usurped from ) in Port Sa'ïd Mus. 21; texts, id. ib. 2-6, 10-12, 31-2.

Wepay , Idu , Itēf-ib , Wepwauthōtp , Themti , Seheres , Wepay , in Taṅṅa Mus. 550-4, 556-7; texts, id. ib. 15-28.

'Ankhef , Khety , Senkau (?) , Hēnnu , Neferuiker , and Puit , Dyn. VI-XII, in Brit. Mus. 29575, 46630-4; names, *Guide to the First, Second and Third Egyptian Rooms* (1924), pp. 41, 78, 79-80; of Khety (29575), *Guide to the First and Second Egyptian Rooms* (1904), pp. 55-6.

Sarcophagus of Tenainūfer , Ptolemaic; text, DARESSY, *Sarcophage ptolémaïque d'Assiout in Ann. Serv.* xvii. 95-6.

Statues.

Sandstone statue of Hētep , in cloak, Middle Kingdom, in Berlin Mus. 15700, BISSING, *Denkmäler*, 23; STEINDORFF, *Die Kunst der Ägypter*, p. 205 [right]; SCHÄFER and ANDRAE, *Die Kunst des alten Orients*, 275 [left]; BLACKMAN in ROSS, *The Art of Egypt through the Ages*, p. 135 [2]; text, *Aeg. Inscr. Mus. Berlin*, i. 145.









Statue of Kha'emwēset , High priest of Ptaḥ, Chief carpenter, son of Ramesses II, probably originally from Abydos, in Brit. Mus. 947, SHORTER, *The Statue of Khā'emuas in the British Museum in Studies presented to F. Ll. Griffith*, pls. 12, 13, cf. pp. 128-32; omitting texts, TEYNARD, *Égypte et Nubie* (1858), pl. 18; MASPERO, *Hist. Anc. des Peuples de l'Orient, Les Premières Mêlées*, fig. on p. 426; BUDGE, *Egyptian Sculptures in the British Museum* (1914), pl. xxxvi; *Guide to the Egyptian Collections* (1909), fig. on p. 246; (1930), p. 369, fig. 203; see *Guide, Sculpture* (1909), p. 170 [615].







Wooden statuette, Middle Kingdom, probably from here, in Copenhagen, Ny Carlsberg Mus. Æ.I.N. 671, SCHMIDT, *Choix de monuments Égyptiens* (1906), pl. 192 [A 39]; id. *Den Aegyptiske Samling* (1908), fig. on p. 93 [E 45]; MOGENSEN, *La Collection égyptienne*, pl. xiv [A 62], cf. p. 16; head, CAPART, *L'Art Égyptien* (1911), pl. 137.

Base of statuette of Tshenkons , Sistrum-player of Amen-rē', Late Period; text, KAMAL, *Rapport sur les fouilles faites dans la montagne de Sheikh Saïd in Ann. Serv.* x. 154 [iii].

Offering-tables, &c.

Hēpzefa , Overseer of the seal, Dyn. XII, in Cairo Mus. 23042, KAMAL, *Tables d'Offrandes* (Cat. Caire), pp. 37-8.

Shemsui , Abes , Khety  and Khetya , Middle Kingdom, Merer , Wepty , Hētep , and Wepemy , headrest of Tha  and fragment of offering-table; texts, id. op. cit. in *Ann. Serv.* xvi. 96, 97, 100, 105, 109, 111-12 [111°, 112°, 113°, 124°, 133°, 136°, 148°, 151°, 153°].

Ipyt , Wepay  (two), 'Aḥakhu , Hētepi  with Hēpzeft  and Int , and Ḥar (?) seḥt , Dyn. XII, in Brit. Mus. 980, 976, 973, 974, 990, 929; names, *Guide*, Sculpture (1909), pp. 77-8 [262, 264-8].

DEIR DURUNKA

NECROPOLIS

TOMB OF SI-ISIT , Overseer of the Granaries of Upper and Lower Egypt.

Texts from coffin and ushabti, and name from fragment of bas-relief, KAMAL, *Fouilles à Deir Dronka et à Assiout* in *Ann. Serv.* xvi. 79 [55°].

TOMB OF AMENḤOTP , Royal scribe; Head of the festival; Overseer of priests. Dyn. XVIII or XIX. (Cf. son Yuny, infra.)







Sepulchral Chamber.





Three walls, judgement scene, deceased and wife in scenes of offering, and deceased conducted by Ḥathor to Horus and Anubis, in Asyût Mus.; texts, id. ib. 90-3 [89°].

MISCELLANEOUS

(From Deir Durunka, but exact provenance unknown.)

Coffins.

Shepsu-heres , 'Ankh , in Ṭanṭa Mus. 766, Ḥeka , in Ṭanṭa Mus. 549, Wepay  (woman), usurped by Khety , in Minya Mus. 274, three of Hēpzefta , son of Idy , Middle Kingdom; texts, KAMAL, op. cit. in *Ann. Serv.* xvi. 71-3, 75-9, 81-2, 84-6 [36°, 53°, 54°, 59°, 72°]; of 'Ankh, Ḥeka, and Wepay, GAUTHIER and LEFEBVRE, op. cit. in *Ann. Serv.* xxiii. 29-30, 13-15, 6-8.

Weriū  (alternatively Wepwaut ) and Zedḥutefonkh , son of Hētep , Ptolemaic; texts, KAMAL, op. cit. 83-4 [68°], 94-5 [103°].

Inpu  and Ḥatkau , Graeco-Roman; texts, id. ib. 80-2 [58°], 84 [71°].

Statues.

Kneeling statue of Yuny , Chief royal scribe, son of Amenḥotp (cf. supra), holding naos containing statue of Osiris, in Asyût Mus.; texts, id. ib. 86-9 [74°].



Double-statue of Yuny and wife Rennut , with stela on back, Dyn. XVIII or XIX, in New York, Metropolitan Mus., WINLOCK, *The Statue of Iny and Rennut in N. Y. Metro. Bull.* Feb. 1919, figs. on pp. 33, 35.

Statuette of Hēpzeft'ankh , Sealer, Middle Kingdom; texts on base, KAMAL, op. cit. 101 [129°].

Wooden funerary statuette of Si-Isit , Overseer of the Two Granaries, found in Ptolemaic tomb; texts, id. ib. 73-4 [42°].

Offering-tables, &c.

Offering-table of Hēpzefi ; texts, id. ib. 86 [73°].

Canopic jar of Hēpzefa  and offering-table of Renmest (?)  (?); names, id. ib. 67 [9°], 69 [25°].

Fragment of offering-table of Zefia . . . ; name, id. ib. 69 [30°].

Inscribed limestone fragment; text, id. ib. 69 [31°].

ADDENDA

TO ALEXANDRIA, PAGE 6

Block of Psammetikhos II, part of red porphyry seated statue and upper part of black stone statue of Hōr , Commander of troops, both Roman, WILKINSON MSS.* ix. 128, xviii. 67 [lower], 68.



TO ŞÂN EL-ĤAGAR (TANIS), PAGE 13

Blocks and texts from obelisks, &c., WILKINSON MSS.* xvii. H. 37, 37 A, 37 B [right, and left lower].

TO ŞÂN EL-ĤAGAR (TANIS), PAGE 20

Block 118, Merneptah before Nefertem, WILKINSON MSS.* xvii. H. 37 B [left upper].

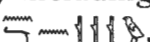
TO EL-MAṬARĪYA, PAGE 62

SAITE TOMBS, including those of PSAMMETHEKSONB , ESENĶEDU , and Hōr , good name NEFEREBRĒ' SINEITH .

Description, plans, and sarcophagi, GAUTHIER, *Découvertes récentes dans la nécropole d'Héliopolis* in *Ann. Serv.* xxxiii, pp. 27-53, figs. 1-4, pls. i-vii.



I. Delta.

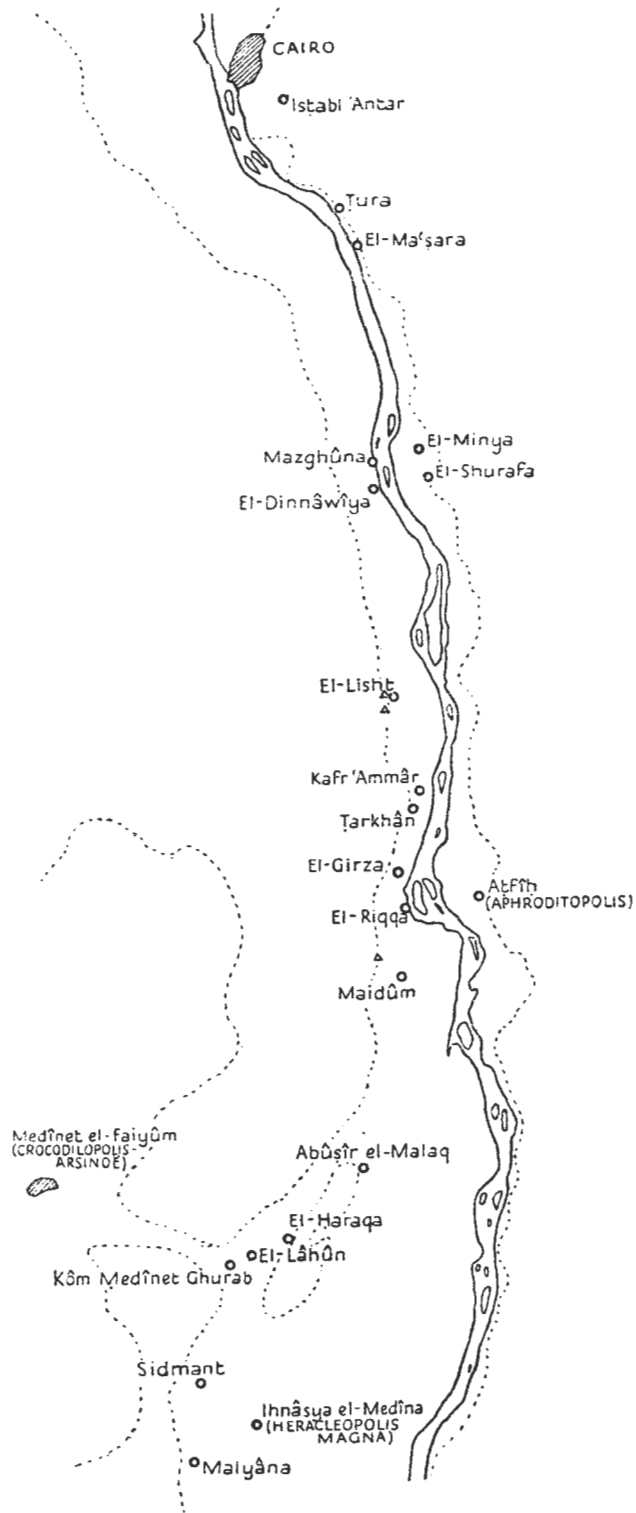

II. Cairo to Ichnâsya el-Medîna.

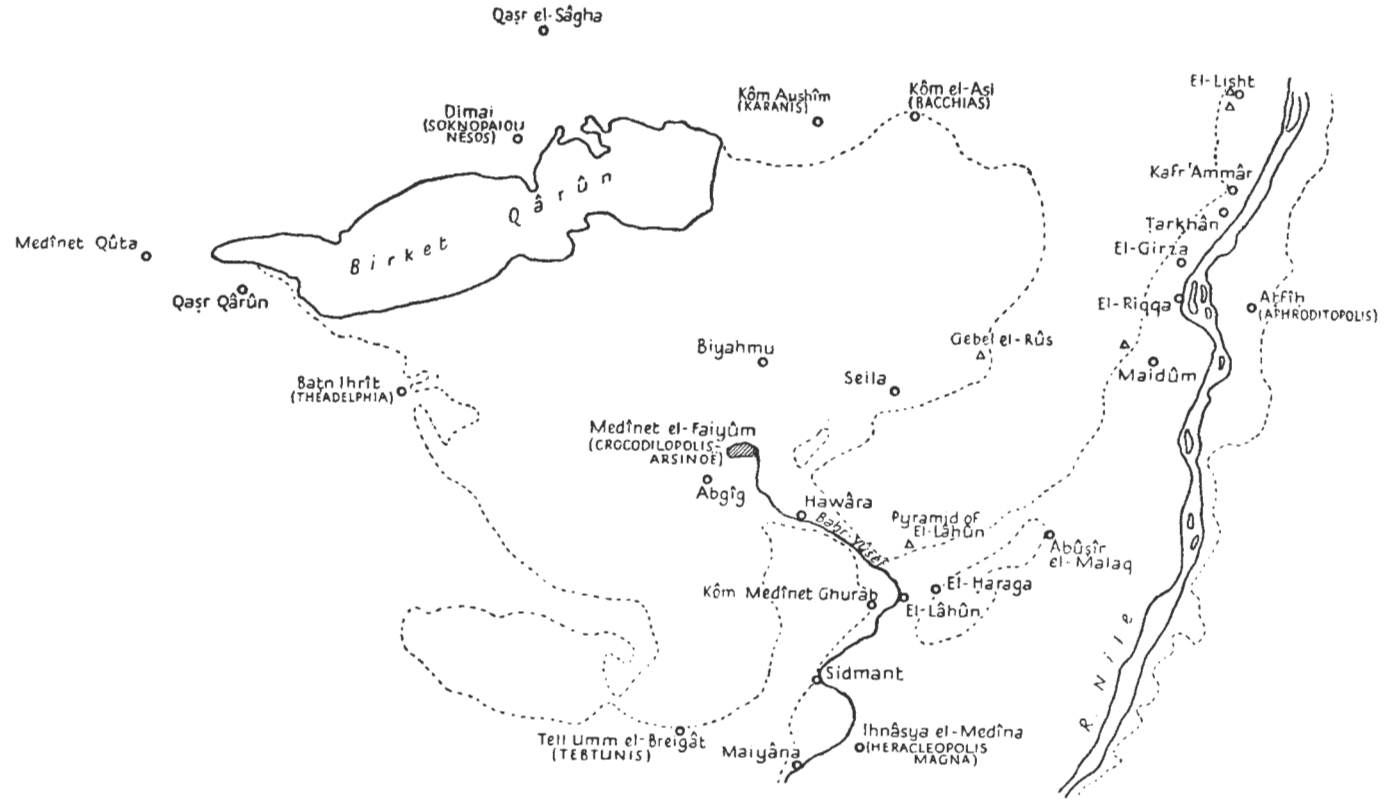

III. El-Faiyûm.

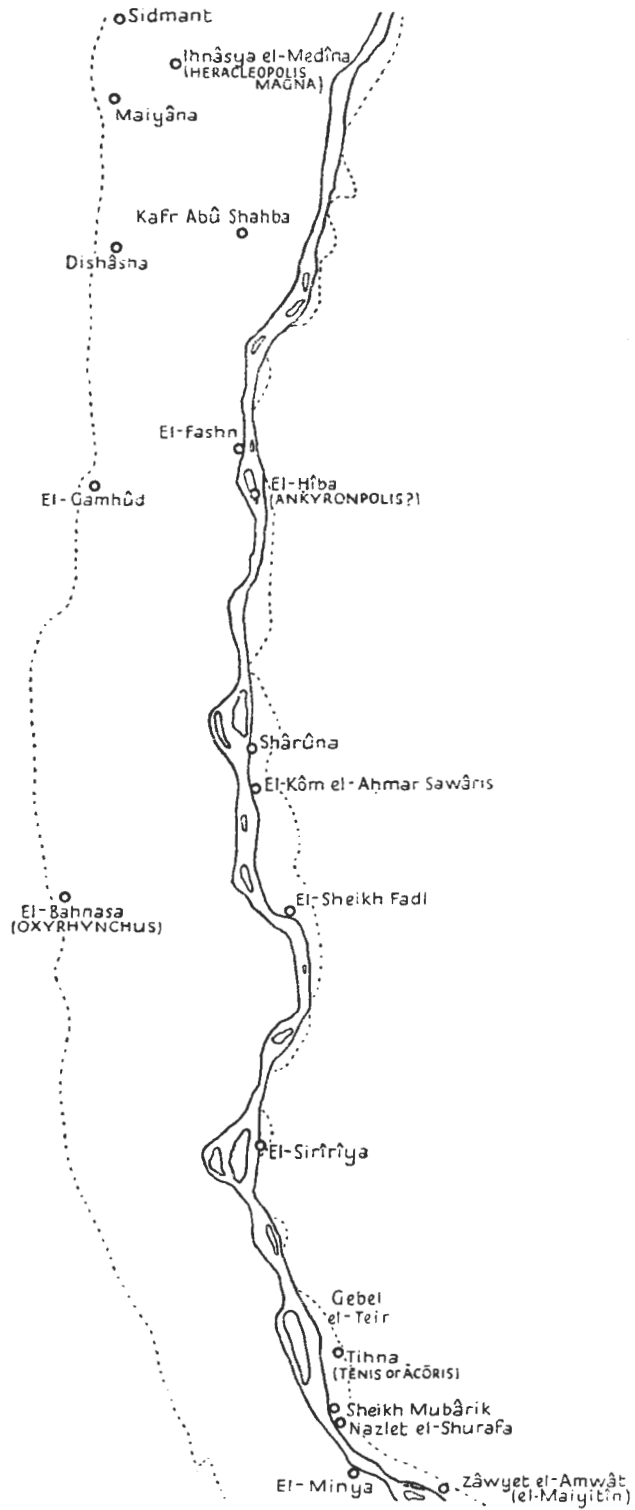

IV. Ihnâsya el-Medîna to Zâwyet el-Maiyitîn.



V. Zawayet el-Maiyitîn to Asyût.

INDEX

KINGS, PERIODS [ETC.]

For members of a royal family other than the reigning queens Sebekneferurē', Hatshepsut, and Cleopatra, see Private Names Index.

- Achoris, 5, 32, 68, 72, 75, 119, 123.
A. D. 71, 57; 1st-2nd centuries, 130.
 Akhenaten, *see* Amenophis IV; in titles, 214.
 'Akheprurē', *see* Amenophis II; in titles, 227.
 Akkadian, 52.
 Alexander the Great, 3, 58, 169; temple of, 165-7.
 Alexander II, 43, 49, 73, 165, 169.
 Amasis, 5, 6, 33, 35, 36, 45, 46, 48, 51, 55, 66, 71, 72, 73; temple of, 8, 72; in titles, 47; in the time of, 46; mother of, *see* Tshenēsi.
 Amenemhēt I, 9, 18, 20, 30, 63, 81, 98, 99, 151; pyramid of, 77-9, 81; in titles, 81; in the time of, 149, 249; mother of, *see* Nefert.
 Amenemhēt II, 8, 9, 18, 57, 168; in the time of, 73, 238, 249, 251, 264.
 Amenemhēt III, 9, 51, 52, 57, 74, 98, 99, 103, 109, 119, 238; pyramid of, 100; labyrinth of, 100-2; in the time of, 57, 65, 81, 96; daughters of, *see* Neferu-Ptah, Sebekneferurē'.
 Amenemhēt IV, 2, 103; pyramid of, 76-7.
 Amenemhēt VI (?), 43.
 Amenophis II, 30, 60, 64, 74; in titles, *see* 'Akheprurē'; in the time of, 117; wife of, *see* Tī'a.
 Amenophis III, 31, 61, 65, 70, 74, 90, 112, 113, 114, 115, 139, 185, 198, 199, 201, 203, 208, 212, 236; in the time of, 31, 114, 115, 116, 117; wife of, *see* Teye; daughters of, *see* Beketaten, Hent-taui-neb, Isit, Sitamün; in titles, *see* Nebma'etrē'.
 Amenophis IV (Neferkheprurē'), later Akhenaten, 61, 63, 70, 112, 113, 121, 168, 169, in 'Amarna, passim (192-237), 259; temples of, 174, 195-7, 207-8, 259; palaces of, 193, 197-9, 208; chapel of, 175; in the time of, 31, 89, 115, 165, 167, 193; wife of, *see* Nefertiti; daughters of, *see* 'Ankhesenpa-aten ('Ankhesenamün), Meketaten, Merytaten, Nefer-neferu-aten; in titles, *see* Neferkheprurē' and Akhenaten.
 Amosis, 69, 74; wife of, *see* Ahmosi Nefertere; son of, *see* Sipaar; daughter of, *see* Meramün.
 Antoninus Pius, in the time of, 174.
 Apophis I, in the time of, 104.
 Apophis II, 16, 17, 19, 28, 29, 69.
 Apries (Wehebrē'), 7, 24, 26, 36, 39, 42, 48, 49, 54, 61, 64, 66, 71, 72; in the time of, 32, 44, 60, 63, 64, 71.
 'A-seh-rē', 25; mother of, *see* Per. . .
 Aten, *see* Divinities Index.
 Augustus, 4, 45.
 Aupweth, 38, 58; wife of, *see* Tent-ket[wa].
 Ay, *see* Private Index.
B. C. 22, 4; 1st century, 174; 4th century, 169.
 Caesar Germanicus, 241.
 Cambyses, 55.
 Caracalla, 36.
 Cleopatra, Needles of, *see* Various Index.
 Cuneiform, 199, 207.
 Darius I, 34, 44, 52, 104.
 Demotic, 15, 26, 54, 97, 103, 124, 241, 264.
 Dynasty I, 85, 86.
 Dynasties I-III, 110, 111.
 Dynasty II, 85, 115.
 Dynasties II-IV, 57.
 Dynasties II-VI, 115.
 Dynasty III, 61, 90, 94, 95, 103, 105, 115, 134, 163.
 Dynasties III-XI, 85.
 Dynasty IV, 85, 87, 94, 95, 105, 163.
 Dynasty V, 77, 85, 95, 103, 119, 123, 131, 163.
 Dynasty VI, 27, 61, 62, 77, 90, 103, 115, 116, 119, 123, 125, 126, 134-9, 161, 163, 239, 243, 244, 258.
 Dynasties VI-XII, 161-3.
 Dynasties VII-X, *see* First Intermediate Period.
 Dynasty VIII, 118.
 Dynasty IX, 55, 111, 115, 116, 258, 263, 264, 265.
 Dynasties IX-XII, 265-7.
 Dynasty X, 86, 115, 116, 149, 258, 263, 264, 265.
 Dynasty XI, 9, 49, 86, 107, 118, 149, 151, 154, 159, 160, 187, 258, 262.
 Dynasty XII, 9, 29, 30, 57, 75, 81, 83, 87, 90, 95, 98, 101, 102, 105, 107, 110, 111, 112, 118, 119, 141-61, 161, 163, 177-83, 185, 187, 189, 191, 235, 254, 256, 258, 259, 262, 267, 268, 269.
 Dynasty XIII, 19, 20, 23, 31, 32, 38, 43, 57, 65, 98, 103, 107, 111, 143, 246.

- Dynasty XVI, 29.
 Dynasty XVII, 169.
 Dynasty XVIII, 11, 23, 33, 53, 57, 60, 75, 87, 89, 90, 94, 95, 96, 97, 105, 110, 111, 112, 113, 114, 115, 116, 118, 121, 139, 168, 192, 237, 269.
 Dynasties XVIII-XX, 169.
 Dynasty XIX, 8, 9, 10, 21, 23, 31, 34, 38, 44, 56, 57, 64, 65, 87, 89, 90, 95, 101, 107, 113, 114, 115, 117, 118, 119, 139, 166, 167, 169, 174, 237, 269.
 Dynasty XX, 9, 13, 23, 31-2, 55, 57, 60, 62, 65, 71, 75, 102, 118, 204, 207.
 Dynasties XX-XXVI, 102, 130.
 Dynasties XX-XXX, 163.
 Dynasty XXI, 32, 124, 133.
 Dynasty XXII, 11, 20, 32, 33, 34, 38, 44, 54, 94, 95, 110, 111, 114, 119.
 Dynasties XXII-XXIV, 110.
 Dynasties XXII-XXV, 36, 111.
 Dynasties XXII-XXVI, 56, 57, 87, 89, 95.
 Dynasty XXIII, 46, 58, 62, 101, 119, 121.
 Dynasties XXIII-XXV, 85, 86.
 Dynasties XXIII-XXX, 118.
 Dynasty XXIV, 66.
 Dynasties XXIV-XXVI, 35.
 Dynasty XXV, 62, 66, 86.
 Dynasty XXVI, 5, 6, 20, 34, 47, 48, 49, 60, 61, 62, 66, 72, 87, 98, 102, 124, 207.
 Dynasties XXVI-XXX, 65, 104.
 Dynasty XXIX, 37.
 Dynasty XXX, 9, 13, 67, 73, 95, 102, 105, 121.

 First Intermediate Period (Dynasties VII-X), 64, 105, 110, 114, 116, 268.

 Graeco-Byzantine, 176.
 Graeco-Egyptian, 6, 97.
 Graeco-Roman, 57, 95, 97, 105, 121, 126, 128, 129, 130, 169, 256, 257, 258, 259, 265, 269.
 Greek, 1, 4, 15, 24, 54, 95, 96, 97, 98, 103, 124, 130, 171, 212.

 Hadrian, 33.
 Haremhab, 63, 70; in the time of, 32.
 Harnedyotf, 246.
 Hatshepsut, 168, 199; temple of, 163-4.
 Hellenistic, 37.
 Hieratic, 77, 90, 107, 142, 143, 144, 146, 158, 208, 209, 221, 237, 238, 255.
 Hyksos, 16, 17, 22, 25, 28, 49, 53, 56, 57, 69, 105, 107, 238.

 Isesi, in titles, 54.

 Jewish, 57.

 Khephren, 28, 69, 85.

 Khety II, 184.
 Khety, 55.
 Khufu, 28, 45, 237; in titles, 94, 187.
 Khui, 259; pyramid of, 258.
 Khyan, 29.

 Late Period, 3, 5, 8, 11, 23, 24, 25, 26, 27, 37, 38, 65, 66, 69, 94, 104, 125, 130, 239, 268.

 Median, 52.
 Menkheperre', 124, 133; wife of, *see* Esenkhebi.
 Menthisuphis, *see* Merenre' II.
 Mentuhotp V, *see* S'ankhkarē.
 Merenre' I, 237; in titles, 54; in the time of, 239.
 Merenre' II (Menthisuphis), in the time of, 249.
 Merkarē', 258; in the time of, 263.
 Merneptah (*see also* Private Index), 2, 3, 5, 8, 15, 16, 17, 18, 20, 22, 23, 24, 25, 30, 35, 38, 44, 45, 55, 56, 63, 67, 70, 113, 118, 121, 167, 168, 237, 270; rock-chapel of, 126-7; in the time of, 59; son of, *see* Sety-Merneptah, later Sethos II.
 Mery..., in the time of, 237.
 Meryebre' Khety, 258.
 Middle Kingdom, 8, 15, 19, 20, 21, 22, 23, 25, 26, 29, 30-1, 37, 51, 53, 55, 57, 63, 68, 69, 70, 77, 85, 96, 101, 102, 105, 107, 112, 134, 161, 162, 165, 168, 176, 177, 183-5, 187, 207, 237, 238, 243, 246, 247, 257, 259-65, 267, 268, 269.
 Mre-mesha, *see* Smenkhkarē Mre-mesha.

 Nebma'etre', *see* Amenophis III; in titles, 224.
 Necho II, 45, 46, 68, 74.
 Neferfrē', in the time of, 183.
 Neferhotep I, 103.
 Neferkarē', *see* Pepy II; in titles, 243, 244.
 Neferkarē', *see* Petubastis.
 Neferkha'urē', 143.
 Neferkheprurē', *see* Amenophis IV; in titles, 218, 225.
 Nehesi, 20, 37, 38.
 Nektanebos I (Nekht-neb-f), 1, 2, 5, 7, 10, 10-11, 13, 34, 40, 44, 49, 50, 55, 60, 67, 69, 72, 168; temples of, 40, 68; in the time of, 42.
 Nektanebos II (Nekht-har-ḥebi), 3, 5, 10, 13, 30, 32, 34, 36, 39, 42, 44, 54, 55, 61, 66, 75, 119, 175; temples of, 40, 43, 55-6, 104; obelisks of, 72-3, 168; in the time of, 33, 40.
 Nepheritis I, 37.
 Nero, 96; temple of, 128, 129, 130.
 Neuserre', in titles, 188.

- New Kingdom, 5, 7, 22-3, 31, 33, 34, 61, 63, 69-71, 86, 96, 114, 116-18, 139, 174, 237, 264, 265.
- Old Kingdom, 24, 25, 28, 36, 64, 69, 77, 79, 81, 86, 95, 96, 97, 103, 107, 111, 114, 121, 123, 127, 134, 161, 162, 183, 187, 207, 237, 239, 242-6, 254, 255, 256, 257, 259, 267.
- Osorkon I, 28, 29, 32, 58, 76; temple of, 32, 124.
- Osorkon II, 14, 17, 25, 28-9, 30, 32, 37, 39, 54, 75; in the time of, 53; wife of, *see* Kera'm'; daughters of, *see* Kera'm', Tashakheper, Thesubaste-perut... armer.
- Osorkon III, mother of, *see* Mery-Mut Kera'm'.
- Osorkon IV, 34; mother of, *see* Tedubaste.
- Pemū, in the time of, 33.
- Penamūn, 68.
- Pepy I (Meryrē'), 14, 18, 29, 58, 69, 237; in titles, 54; in the time of, 62, 247.
- Pepy II (Neferkarē'), 14, 62, 237, 238; in titles, 54, 137, 138; in the time of, 238, 239, 247, 249, 254, 255.
- Pepy, in titles, 136, 189, 191.
- Persian, 37, 47, 52, 54, 71, 112.
- Petubastis (Neferkarē'), 119, 121; wife of, *see* Tshenēsi.
- Petubastis I, 121.
- Philip Arrhidaeus, 27, 43, 58; temple of, 165-7; in the time of, 66.
- Pinezem I, 16, 124.
- Pompey, Pillar of, *see* Various Index.
- Post New Kingdom, 62, 66.
- Predynastic, 78, 89, 105, 111, 134.
- Protodynastic, 54, 85, 99, 110, 114.
- Psammetikhos I (Weḥbre'), 1, 2, 3, 7, 26, 33, 35, 36, 40, 48, 58, 64; in the time of, 39, 44, 46, 67, 71, 119, 121.
- Psammetikhos II, 33, 42, 46, 48, 49, 52, 68, 71, 74, 270; in the time of, 46, 54, 58, 64.
- Psammetikhos, 24.
- Psusennes I, 13, 14, 16, 17, 20-1, 23, 24, 25.
- Ptolemaic, 1, 2, 3, 6, 9, 10, 11, 12, 15, 21, 23-4, 25, 27, 28, 35, 36, 37, 38, 43, 45, 47, 48, 50, 57, 63, 66, 67, 68, 73, 75, 76, 77, 83, 85, 87, 94, 95, 96, 97, 98, 99, 100, 102, 103, 104, 124, 125, 134, 167, 265, 268, 269.
- Ptolemy I Soter I, 50, 67, 68, 75, 76, 258; temple of, 126; daughters of, *see* Arsinoë II, Philotera.
- Ptolemy II Philadelphus, 6, 13, 26, 33, 36, 42, 43, 49, 63, 68, 74, 126; temple of, 40-1; chapel of, 23-4; wife of, *see* Arsinoë II.
- Ptolemy III Euergetes I, 15, 42, 51, 73; temples of, 40, 41, 98; wife of, *see* Berenice II.
- Ptolemy IV Philopator, 4, 12, 25, 54; wife of, *see* Arsinoë III.
- Ptolemy V Epiphanes, 1, 50, 130.
- Ptolemy VI Philometor, in the time of, 57.
- Ptolemy IX Neos Philopator, 23.
- Ptolemy XI Alexander I, 66.
- Ptolemy XIII Neos Dionysos, 97.
- Ptolemy, 5, 25, 42, 241.
- Ramesses I, 6, 59, 69.
- Ramesses II, 2, 3, 4, 5, 6, 8, 9, 10, 11, 12, 14, 16, 17, 18, 19, 20, 21, 22-3, 25, 26, 28, 29, 30, 31, 34, 35, 37, 38, 39, 40, 44, 49, 50, 51, 52, 53, 58, 59, 60, 61, 62, 63, 64, 67, 70, 72, 76, 77, 81, 99, 112, 117, 118, 119, 129, 167, 192, 237; temples of, 10, 24-5, 32, 53, 55, 56, 62, 118-19, 121, 166, 168-9, 170, 175-6, 259; obelisks of, 12, 14-15, 15-16, 18, 20, 21, 60, 66, 70; in titles, 10; in the time of, 1, 8, 10, 23, 26, 28, 31, 34, 59, 63, 64, 114, 117, 119, 174; mother of, *see* Tuy; wives of, *see* Hentmarē', Mat-neferu-rē', Nefertari; sons of, *see* Kha'emwaset, Mentuḥirkhopshef, Merneptah; daughters of, *see* Bent'anta, Merytamūn.
- Ramesses III, 8, 10, 17, 25, 26, 29, 34, 35, 38, 44, 55, 58, 60, 71, 127, 130, 131, 208, 267; temple of, 56-7; in the time of, 125.
- Ramesses IV, 71; in the time of, 32.
- Ramesses V, 61.
- Ramesses VI, 31.
- Ramesses VII, 58; in the time of, 59.
- Ramesses IX, 3; in the time of, 104.
- Ramesside, 4, 51, 58, 65, 66, 98, 99, 119, 177.
- Roman, 4, 26, 28, 33, 35, 36, 45, 53, 56, 66, 67, 75, 77, 83, 85, 87, 88, 94, 95, 96, 97, 103, 104, 105, 110, 118, 121, 124, 126, 128, 129, 165, 176, 241, 270.
- Sabacon, 66.
- Saite, 2, 8, 11, 26, 28, 32, 33, 34, 36, 37, 44, 45, 47, 48, 49, 50, 54, 55, 59, 61, 62, 63, 68, 69, 72, 95, 102, 105, 118, 121, 125, 126, 139, 163, 169, 174, 175, 247, 265, 270.
- Saite—Ptolemaic, 65.
- S'ankhkarē' Mentuḥotp V, 9.
- 'Scorpion King', 75.
- Sebekḥotp II (Sekhem-khu-tai-rē'), 30.
- Sebekḥotp III (Sekhem-waz-tai-rē'), 30, 69.
- Sebekḥotp IV, 19, 25, 69, 76.
- Sebekneferurē', daughter of Amenemḥet III, 9, 100, 119; pyramid of, 76.
- Sekhemkarē', 23; wife of, *see* Nebḥotep; son of, *see* Meryrē'.

- Sekhem-khu-taui-rē', *see* Sebekhotp II.
 Sekhem-waz-taui-rē', *see* Sebekhotp III.
 Sesonchis I (*see also* Sheshonk in Private Index), 15, 31, 33, 39, 53, 58, 121; temple of, 124; son of, *see* Nemareth.
 Sesonchis II, 13, 14, 35, 44, 46, 51.
 Sesonchis III, 13, 61, 64; sons of, *see* Bekennif, Pemū.
 Sesonchis IV, 6; in the time of, 33.
 Sesostris I, 3, 9, 18, 30, 63, 69, 84, 86, 99, 237, 238, 246, 261; pyramid of, 80, 81-4; obelisks of, 60, 99; in the time of, 85, 141, 249, 250, 251, 261.
 Sesostris II, 3, 18, 22, 86, 87, 105, 118, 119; pyramid of, 106, 107, 108, 109-10; in the time of, 99, 179, 253; wife of, *see* Nofret (*see also* Atemu[neferu?]).
 Sesostris III, 3, 8, 9, 22, 30, 31, 37, 87, 102, 118, 119, 121; in the time of, 84, 179, 238.
 Sesostris, 69.
 Sethos I, 3, 4, 5, 6, 9, 10, 30, 53, 57, 64, 70, 104; temples of, 60-1, 163-4; palace of, 9; in the time of, 23, 114; wife of, *see* Tuy.
 Sethos II (*see also* Sety-Merneptah in Private Index), 5, 8, 20, 30, 45, 61, 64, 70, 76, 127, 167, 241; in the time of, 10, 58, 114.
 Setnakht, 8, 62, 70.
 Siamūn, 4, 9, 14, 15, 18, 20, 21, 23, 24, 71.
 Siptah, in the time of, 8, 59.
 Smenkharē', 198, 199, 204, 213, 232, 234, 235; in the time of, 209.
 Smenkharē' Mre-mesha, 19.
 Snefru, 95; pyramid of, 88, 89-90; sons of, *see* Neferma'et, Rē'hotp.
 Taharqa, 20.
 Takelothis I, 33.
 Takelothis II, 39; wife of, *see* Mery-Mut Kera'm'.
 Takelothis III, 33.
 Teos, 10, 13, 66.
 Teti, 10; in titles, 136, 189; in the time of, 122, 238.
 Tut'ankhamūn, 113, 114, 206, 232; in the time of, 114, 209; wife of, *see* 'Ankhesenpaten ('Ankhesenamūn).
 Tuthmosis I, 124.
 Tuthmosis III, 4, 5, 60, 61, 63, 69, 90, 115, 165, 169, 185, 198; temples of, 112-13, 163-4; in the time of, 38, 57, 77, 87, 116.
 Tuthmosis IV, 5, 58, 60, 99, 204; temple of, 233; in the time of, 104; mother of, *see* Tī'a.
 Tuthmosis, 49.
 Userkaf, in titles, 187; in the time of, 131.
 Userma'etrē', *see* Ramesses II; in titles, 119.
 Userpehti, 58.
 Wehebrē' (Dyn. XIII), 111.
 Wehebrē' (Dyn. XXIV or XXV), 66.
 Wehebrē', *see* Apries.
 Wehebrē', *see* Psammetikhos I.
 Xerxes, 52.
 Zet, in the time of, 86.
 Zoser Neterkhet, 61; daughters of, *see* Hetephernebti, Intkaes.

PRIVATE NAMES

An asterisk denotes members of royal families.

- | | | |
|-----------------------------|----------------------------|------------------------|
| 'A'auifi, 116. | *Aḥmosi Nefertere, wife of | Amenmosi, 90. |
| Aba, 11. | Amosis, 247. | Amenmosi, 116. |
| Aba, 32. | 'Aḥ-tefnakht, 95. | Ameny (?), 57. |
| Abes, 269. | Akanush, 44. | Ameny, 81. |
| Abu, 137. | Amenardais, 111. | Ameny, 86. |
| 'Aby, <i>see</i> Ukh. | Amenemhēt, 117. | Ameny, 87. |
| 'Aḥakhu, 269. | Amenemhēt, 140, 141-4. | Ameny, 256. |
| 'Aḥanakht, 178, 181-2, 182. | Amenemhēt, 184. | Ameny-senb-nebuu, 102. |
| 'Aḥanakht, 182. | Amenemhēt, 238. | Amenysonb, 112. |
| 'Aḥanakht, 183. | Amenemhēt, 243. | 'Amu, 246. |
| 'Aḥanakht, 238. | Amenheru, 95. | 'Anenen, 65. |
| Aḥmosi (Neferebrē'-nakht), | Amenhotp (?), 5. | 'Ankh, 183. |
| 11. | Amenhotp, 9. | 'Ankh, 269. |
| Aḥmosi, 40. | Amenhotp, 31. | 'Ankh . . . , 183. |
| *Aḥmosi, 59. | Amenhotp, 116. | 'Ankhef, 95. |
| Aḥmosi, 175. | Amenhotp, 269. | 'Ankhef, 266. |
| Aḥmosi, 210, 214. | [Amen]mosi, 64. | 'Ankhef, 266. |

- 'Ankhef, 266.
'Ankhef, 267.
'Ankhef, 268.
'Ankhef, 268.
'Ankhef, 268.
'Ankhefenmut, 102.
'Ankhenrē, 61.
*Ankhesenamūn, *see* 'Ankhesenpa-aten.
'Ankhesenēsi, 63.
*Ankhes(en)mut, 95.
*Ankhesenpa-aten ('Ankhesenamūn), daughter of Amenophis IV, wife of Tut'ankhamūn, 113, 198, 200, 211, 213, 218, 224, 236.
'Ankhetsi, 83, 84.
'Ankh-ḥap, 33.
'Ankh-ḥap, 111.
'Ankh-Ḥarsiēsi, 37.
'Ankh-Ḥor, 44.
'Ankh-Ḥor, 111.
'Ankh-Ḥor, 256.
'Ankhirptaḥ, 95.
'Ankh-khred-nūfer, 53.
'Ankhmesu, 111.
'Ankhnūfer, 86.
'Ankh-pef-hri, 33.
'Ankhpekhrad, 38.
'Ankhruī, 102.
'Ankh-theker, 121.
'Ankhu, 183.
'Ankhu, 256.
'Ankhy, 185.
'Ankhy, *see* Khnem'ankh.
Antef, 64.
Antef, 86.
Antef, 161.
Antefoker, 78, 79.
Antefoker, 112.
'Anti (?), 258.
'Anti-emḥēt, *see* Thauī.
'Antiiu, 238.
'Anu, 267.
'Anu, 267.
Any, 226, 227-8.
Any (?), 237.
Any-men, 227.
'Aok, 54.
Arensekhmet, 111.
*Arsinoë II, daughter of Ptolemy I, wife of Ptolemy II, 6, 13, 23, 24, 26, 36, 48, 54, 63, 74.
*Arsinoë III, wife of Ptolemy IV, 4.
*Arut, daughter of Queen Tshenēsi, 121.
Asekhu, 258.
'Ashōkhi, *see* Bakakhuīu.
Atemhotp, 61.
Atem(?)hotp, 102.
*Atemu[neferu?], wife or daughter of Sesostri II, 109.
Au, 85.
Ay, 8.
Ay, 112.
Ay, 227.
*Ay, afterwards King, 175, 226, 228-30.
Bakakhuīu ('Ashōkhi), 26.
Baḳt I, 150, 160.
Baḳt II, 150, 160-1.
Baḳt III, 150, 151-4.
Baḳt, *see* Senbi.
Bay, 8, 59.
Bay, 34.
Bebi, 126.
Bebi, 161.
Bebi, *see* Meru.
Bebut, 102.
Behesy (?), 189.
Bek (?), 257.
Bekamūn, 87.
Bekenamūn, 10.
Bekemut, 130.
*Bekennif, son of Sesonchis III, 64.
*Beketaten, daughter of Amenophis III and Teye, 211, 212.
Bekhent, 192.
Bekren, 111.
*Bent'anta, daughter of Ramesses II, 16, 119, 121, 168.
*Berenice II, wife of Ptolemy III, 41.
Beri, 87.
Biu, 137.
*Bunūfer, 91.
By, 266.
By, *see* Sebeky.
Dai'onkh, 256.
Debit, 131.
Debit, 133.
Dednu, 267.
Deēsisonb, 99.
Dega, 267.
Derkhesef, 238.
Deubaste-ponb, 33.
Dḥout, 104.
Dḥutardais, 72.
Dḥutardais, 175.
Dḥutef'onkh, 258.
Dḥutey, 174.
Dḥutihotp I, 238.
Dḥutihotp II, 178, 179-81.
Dḥutihotp, 184.
Dḥutihotp, 185.
Dḥutinakht, 182.
Dḥutinakht, 182.
Dḥutinakht, 183.
Dḥutinakht, 183.
Dḥutinakht, 184.
Dḥutinakht, 185.
Dḥutinakht, 189, 191.
Dḥutinakht II, 237.
Dḥutinakht III, 237.
Dḥutinakht IV, 238.
Dḥutinakht V, 238.
Dḥutinakht VI, 177, 178, 179.
Dḥutinakht, 238.
Dḥutmōsi, 117.
Dḥutmōsi, 174, 175.
Dḥutmōsi, 202-3, 234.
Dḥutnūfer, 168.
Dḥutrēkh, 171, 174.
Dor, *see* Tenro.
Duaneteref, 111.
Dusobk (?), 102.
Ef'o (Neferebrē'-mai-neith), 48.
Emē, 35.
Emref'ankh, 131.
Esbanebbed (Esbendetis), 36.
Esbendetis, *see* Esbanebbed.
Esenkedu, 270.
Esenkhebi, 95.
*Esenkhebi, wife of Menkheperrē, 124.
Es-Ḥarpkhrad (Neferebrē'-ankh), 32.
Esmihōs, 38.
Espḥo'an, 32.
[Es]ptaḥ, 11.
Esweben (?), 111.
Eswēre, 54.
Gemit, 256.
Gemshi, 95.
Gua, 187.
Ḥa'a'-ebrē'-tharefneferu, 64.
Ḥa-Ḥaremsekhtu, 116.
Hai, 175.
Ḥai, 258.
Ḥa-ishutf, 257.
Ḥa...nyg...ka..., 259.
Ḥaremḥab, 50.
Ḥaremḥab, 107.
Ḥarhotp, 45.
Ḥarhotp (?), 107.
Ḥarḥurekhyt-hotp, 162.

- Harkhebi, 9.
 Harkhebi, 27.
 Harkhebi, 33.
 Harkhebi, 48.
 Harkhebi, 99.
 Harpaēsi, 39.
 Harpi-ardais, 47.
 Harpi-ardais, 47.
 Har(?)seht, 269.
 Harshefnakht, 105.
 Harsiēsi, 42.
 Haruza, *see* Harwoz.
 Harwoz (?), 11.
 Harwoz, 102.
 Harwoz, 111.
 Hat, 256.
 Ha-theki (?), 114.
 Hatheremhēt, 138.
 Hatheremhēt, 256.
 Hatheremhēt, 256.
 Hatherhotp, 257.
 Hatiay, 196, 200, 217.
 Hatkau, 269.
 Hatres Pasos, 95.
 Hefni, 258.
 Heka, 269.
 Hekekuti, 112.
 Heknen, 90.
 Heksonb, 83, 84.
 Hekwen, 83, 84.
 Helly (?), 38.
 Hem-Hathor, 131.
 Hen, 86.
 Hen, 256.
 Henen, 266.
 Henedi, 256.
 Henedi, 256.
 Henedit, 185.
 Henent, 190, 191.
 Henent, *see* Kay.
 Henenu, 137.
 Henedut, 118.
 Henherib, 257.
 Heniati (Khnebrē'-men),
 72.
 Henib, 257.
 Heni-kem, *see* Pepy'-ankh
 the youngest.
 Henka, 95.
 Henka, 96.
 Henku (Kheteti), 242.
 Henku (Iy . . . f), 240, 242.
 Henni, 185.
 Henu, 268.
 Henten, 268.
 *Hentmarē', wife of Rames-
 ses II, 2.
 Hentni-Khnum, 258.
 *Hent-taui-neb, daughter of
 Amenophis III, 114.
 Henty, 116.
 Henu, 256.
 Henui, 268.
 Heny the middle, 253.
 Heny, 262.
 Heny, 267.
 Heny, 267.
 Heny, 268.
 Heny, *see* Pepy'-ankh-hir-ib.
 Henyhirib, 257.
 Henyhirib, 257.
 Henny, 257.
 Hepemhab, 63.
 Hepi, 75.
 Hepi, 138.
 Hepi, 190, 192.
 Hepi, 249.
 Hepi, 256.
 Hepi'-ankhtefi, 256.
 Hepi-kem, 249.
 Hepi-kem, *see* Ni'ankh-
 Pepy-kem.
 Hepkem, 257.
 Hepmen, 7.
 Hepmen, 7.
 Hepmen (Khenstefnakht),
 72.
 Hepmen, 95.
 *Hepu, 85.
 Hepzefa I, 260, 261-2, 262,
 268.
 Hepzefa II, 262.
 Hepzefa III, 260, 264.
 Hepzefa, 264.
 Hepzefa, 265.
 Hepzefa, 268.
 Hepzefa, 269.
 Hepzefa, 270.
 Hepzefai, 268.
 Hepzefi, 267.
 Hepzefi, 269.
 Hepzefi, 270.
 Hepzefi'ankh, 269.
 Her . . ., 267.
 Heribi or Ipi, 161.
 Herpa, 102.
 Heshneb (?), 112.
 *Hesnebtes, 23.
 Hesy, 107.
 Hetef, 162.
 Hetep, 86.
 Hetep, 121.
 Hetep, 256.
 Hetep, 268.
 Hetep, 268.
 Hetep, 268.
 Hetep, 269.
 Hetep, 269.
 *Hetephernebti, probably
 daughter of Zoser, 61.
 Hetepi, 111.
 Hetepi, 269.
 Hetepka, 118.
 Hetep-neb, 243.
 Hetept, 130.
 Heteptu, 257.
 Heti, 130.
 Het-i'oh, 252, 254.
 Hetzet-heknu, 131.
 Hor, 2.
 Hor, 4.
 Hor, 4.
 Hor, 11.
 Hor, 34.
 Hor (Psammethes), 58.
 Hor, 66.
 Hor, 95.
 Hor, 241.
 Hor (Neferebrē'-sineith),
 270.
 Hor, 270.
 Hor, *see* Pedusiri.
 Hori, 32.
 Hori, 65.
 Hori, 95.
 Hori, 104.
 Hori, 265.
 Hrafaneith, 47.
 Huhotp, 184.
 Huu, 137.
 Huy, 10.
 Huy, 51.
 Huya, 210, 211-12
 Iam, 249.
 Iam-Ptah, 267.
 Iamyt, 107.
 Iay, 113.
 Ib, 87.
 Ibi, 240, 243-4.
 Ibt, 256.
 Idi, 238.
 Idi, 264.
 Idu, 266.
 Idu, 266.
 Idu, 268.
 Idy, 269.
 Ifi, 133.
 Iha, 182.
 Iha, 185.
 Iha, 191.
 Iha I, 238.
 Ihy, 135.
 Ihynes, 105.
 Ihynes, 107.
 I'-ib, 183.
 Iker'ankh, 256.
 Ikui (Izi), 256.
 Im'abim, 105
 Imhōtep, 37.
 Imhōtep, 80, 84.

- Imhōtep, 256.
 Imhōtep, 259.
 Imhōtep, *see* Teti-ankh.
 Impy, *see* Ptaḥshepses.
 Inamūn-nesebu, 111.
 In'ankh, 116.
 Ini, 267.
 Innakht, 119.
 Inpu, 269.
 Inpy, 108, 110-11.
 Inpy, 112.
 Int, 257.
 Int, 269.
 Intersh, 114.
 Inti, 120, 121-2.
 *Intkaes, probably daughter
 of Zoser, 61.
 Iny, 165.
 Ipay, 114.
 Ipi or Heribi, 161.
 Ipi, 162.
 Ipi, 267.
 Ipia, 60.
 Ipwer (?), 112.
 Ipy, 89.
 Ipy, 207.
 Ipy, 223-4.
 Ipyt, 269.
 Iri, *see* Kep (?).
 Iry, 62.
 Is, 112.
 Isesi, 238.
 Isi (Rē-ḥem), 242.
 Isi, *see* Rē-ḥem.
 Isidora, 174.
 *Isit, daughter of Ameno-
 phis III, 114.
 Istoḳer, 256.
 It, 138.
 Ita I, 83, 84.
 Ita II, 83.
 Itef-ib, 266.
 Itef-ib, 268.
 Itef-ibi, 267.
 Itenḥab, 105.
 Itet, 92, 93-4.
 Iteti (Shedu), 120, 122-3.
 Ithat, *see* Khenti.
 Ithu, 104.
 Iti, 105.
 Iti, 136.
 Iuaa, 200.
 Iu-nūfer (?), 102.
 Iuti, 212.
 Iuy, 257.
 Iy (?), 230.
 Iy, *see* Kha'kheperrē-sonb.
 Iy . . . f, *see* Henḳu.
 Iymery, 120, 127.
 Iyni, 257.
 Iyni, 257.
 Izi, *see* Ikui.

 Kaḥap, 133.
 Kaḥap, 133.
 Kaḥap, 188.
 Kamosi, 169.
 Kanakht, 238.
 Kay, 85.
 Kay, 181, 238.
 Kay, 181.
 Kay, 184.
 Kay, 187.
 Kay (Henent), 249.
 Kay (?), 257.
 Kayt, 249.
 Kayt, 249.
 Kayt, 257.
 Keḏetnes, 255.
 Kemtet, 107.
 Ḳen, 59.
 Kenemsu, 107.
 Kep (?) (Iri), 32.
 Kera'm', wife of Osorkon II,
 28.
 *Kera'm', daughter of Osor-
 kon II, 28.
 *Kera'm', *see* Mery - Mut
 Kera'm'.
 Kha'emtar, 99, 101.
 *Kha'emwēset, son of Ra-
 messes II, 31, 133, 268.
 Kha'emwēset, 61.
 Khai, 258.
 Kha'kheperrē-sonb (Iy),
 254.
 Kha'ptaḥ, 33.
 Kha'y, 10.
 Khenems-Ḥarmenkhīb-wēr,
 46.
 Khenemskhred, 110.
 Khensorudi (?), 66.
 Khenstefnakht, *see* Ḥepmen.
 Khenstefnakhti, 125.
 Khent, 92.
 Khentekhtaihotp, 43.
 Khentekhtiamsaf-sonb, 107.
 Khenti (?), 73.
 Khenti (Ithat), 256.
 Khentikher, 75.
 Khent-kheti, 116.
 Khent-khety-em-ḥēt, 95.
 Khenu-ka, 132, 133.
 Khenu-ka, 133.
 Kher, 11.
 Kherfu, 31.
 Khesu-wer, 51-2.
 Kheteti, 137.
 Kheteti, *see* Henḳu.

 Khetety, 266.
 Kheti, 266.
 Khety, 86.
 Khety, 112.
 Khety, 150, 152, 154-9.
 Khety, 162.
 Khety, 257.
 Khety I, 264.
 Khety II, 260, 263-4, 264,
 265.
 Khety, 266.
 Khety, 267.
 Khety, 268.
 Khety, 269.
 Khety, 269.
 Khetya, 269.
 Khetyi, 162.
 Khetysonb, 83, 84.
 Khnem'ankh ('Ankhy), 238.
 Khnem'ankh, 256.
 Khnemembrē-men, *see* He-
 niati.
 Khnememḥēt, 86.
 Khnemḥesef, 136.
 Khnemḥotp I, 140, 149-51.
 Khnemḥotp II, 140, 149, 159.
 Khnemḥotp III, 140, 144-9.
 Khnemḥotp IV, 149.
 Khnemḥotp, 142.
 Khnemḥotp, 162.
 Khnemḥotp, 251.
 Khnemḥotp, 256.
 Khnemḥotp, 256.
 Khnemḥotp, 256.
 Khnemḥotp, 256.
 Khnemḥotp, 257.
 Khnemḥotp, 257.
 Khnemḥotp, 257.
 Khnemḥotp-ḥepi, *see* Ni-
 'ankh-Pepy.
 Khnemḥotpi, 162.
 Khnem (?) -nakht, 182.
 Khnemnekhti, 162.
 Khnemuḥotp, 256.
 Khu, 267.
 Khuenḥor, 62.
 Khuenukh, 239, 240, 241.
 Khuenukh-Neferḥōtep, 241.
 Khui, 258.
 Khui, 258.
 Khui, 259.
 Khui, 259.
 Khui, *see* Pepy-ankh.
 Khunes, 132, 134-5.
 Khuni-'Anti (?), 266.
 Krates, 50.

 Ma, 135.
 Ma, 137.
 Ma, 162.
 Maa-nekhtutef, 205.

- Ma'et, 266.
 Ma'etemakhet, 102.
 Ma'hu, 165.
 Ma'hu, 220, 222-3.
 Maket, 112.
 Marres, *see* Nema'etrē'.
 M'asen (?), 267.
 *Mat-neferu-rē', wife of Ramesses II, 16.
 Ma'y, 185.
 Mehahiy, 127.
 *Meketaten, daughter of Amenophis IV, 63, 213, 216, 224, 230, 232, 235, 236.
 Men, 57.
 Men, 256.
 Meni (Menia), 255.
 Menia, *see* Meni.
 Menkheper, 200.
 Menkhet, 83.
 Menna, 118.
 Mentemtau, 66.
 *Mentuhirkhopshef, son of Ramesses II, 31.
 Mentuhotp, 81.
 Mentuhotp, 84.
 *Meramün, daughter of Amosis, and sister of Prince Sipaar, 168.
 Merer, 269.
 Mereri, 105.
 Mereri, 138.
 Merery, 256.
 Meres'ankh, 133.
 Mer-Har-yotf, 66.
 Meri, 123.
 Meri'ankh, 112.
 Mer-ih, 23.
 Merirē', 114.
 Merna, 118.
 Merneith, 86.
 Merneptah, 8.
 *Merneptah, afterwards king, son of Ramesses II, 22, 31, 66.
 Mer-shent (?), 176, 177.
 Mersi, 251.
 Mersi (perhaps same as last), 251.
 Mert-Hathor, 119.
 Meru, 61.
 Meru (Bebi), 189, 190.
 Meru, 190, 191.
 Meru, 238.
 Meru, 256.
 Merut, 126.
 Merut, 246.
 Mery, 133.
 Meryib, 256.
 *Mery-Mut Kera'm', wife of Takelothis II, and mother of Osorkon III, 39.
 *Meryrē', probably son of Sekhemkarē', 65.
 Meryrē' I, 210, 214-17.
 Meryrē' II, 210, 212-14.
 Meryrē'-hashetef, 115.
 *Merytamün, daughter of Ramesses II, 16, 121.
 *Merytaten, daughter of Amenophis IV, 64, 168, 193, 211, 213, 216, 223, 224, 230, 232, 234, 236.
 Mesehti, 265.
 Mesehti, 267.
 Mesehti, 268.
 Mesti, 258.
 Mey, 89.
 Mey, 220, 225.
 Min, 38.
 Minmosi, 8.
 Minmosi, 116.
 Mosi, 26.
 Mutardais, 125.
 *Mutbenret, sister of Queen Nefertiti, 218, 224, 225, 227, 228, 229.
 Mutnūfer, 165.
 Nakht, 79.
 Nakht, 83, 84.
 Nakht, 80, 84.
 Nakht, 142.
 Nakht, 187.
 Nakht, 196, 206.
 Nakht, 256.
 Nakht, 257.
 Nakht, 266.
 Nakht, 266.
 Nakht, 266.
 Nakhta, 256.
 Nakhti, 266.
 Nakhti, 268.
 Nakhtubasterau, 111.
 Nana, 96.
 Na'r, 113.
 Nebamün, 26.
 Nebamün, 114.
 'Neb-em-suhet', 116.
 Nebenkemt, 116.
 *Nebhōtep, wife of Sekhemkarē', 23.
 Nebhōtep (perhaps same as Nebuhōtep), 117.
 Neb-ib, 242.
 Nebiri, 118.
 Nebiri, 259.
 Nebma'etrē'-nakht, *see* Sah-nūfer.
 Nebmertef, 44.
 Neb-neteru, 113.
 Nebpu, 107.
 Nebpu, 107.
 Nebsen, 87.
 Neb-si, 34.
 Nebt, 256.
 Nebt, 257.
 Nebt-het, 248, 251.
 Nebuhōtep (perhaps same as Nebhōtep), 117.
 Nebwa', 32.
 Nebwawi, 227.
 Nechothyris, 124.
 Neferebrē'-ankh, *see* Es-Harpkhrad.
 Neferebrē'-em-akhet, 64.
 Neferebrē'-mai-neith, *see* Ef'o.
 Neferebrē'-nakht, *see* Ah-mosi.
 Neferebrē'-nebpehti, *see* Uzahor-shema'nt.
 Neferebrē'-sineith, *see* Hor.
 Neferebrē'-sineith, *see* Nekht-Harhebi.
 Neferi, 181, 184.
 Nefer-it, 62.
 Neferka, *see* Pepy'-ankh-hir-ib.
 Neferkau, 239.
 Neferkhepru-her-sekheper, 224.
 *Neferma'et, son of Snefru, 92-4.
 *Nefer-neferu-aten, daughter of Amenophis IV, 211, 219, 236.
 Nefernef-khetu, 246.
 Neferpert, 74.
 Neferronpet, 26.
 Nefersab, 257.
 Nefersekheru, 132, 139.
 Neferseshemseshet, *see* Sheshi.
 *Nefert, probably mother of Amenemhēt I, 81.
 Nefert, 90, 92.
 *Nefertari, wife of Ramesses II, 58, 70.
 Nefertep-wa (?), 246.
 *Nefertiti, wife of Amenophis IV, 168, in Amarna, passim (192-237), 259; palace of, 193, 194, 196; in titles, 212, 228; sister of, *see* Mutbenret.
 Nefertkau, 131.
 *Neferu (Neferu-sheri), 79.
 Neferuiker, 268.

- Neferunt . . . , 105.
 *Neferu-Ptah, daughter of Amenemhet III, 69, 82, 100.
 *Neferu-sheri, *see* Neferu.
 Nefery, 161.
 Nefer-zebi, 185.
 Nefer . . . u, 94.
 Neha, 68.
 Nehem'a(w)y, 168.
 Nehem-maatiu, 209.
 *Nehep, 92.
 Neher, 87.
 Neheri, 62.
 Neheri, 138-9.
 Neheri, 162.
 Neheri I, 181, 238.
 Neheri, 182.
 Neheri, 184.
 Neheri, 187.
 Neheri, 187.
 Nehir, 257.
 Neith-neb, 116.
 Neka'-ankh, 131, 132.
 Nekht'ankh, 187.
 Nekht-Harhebi (Neferebrē'sineith), 47.
 Nekht-Harhebi (Nekht-Harmenkhīb), 48.
 Nekht-Harmenkhīb, *see* Nekht-Harhebi.
 Nekhti, 159.
 Nekhti, 159.
 Nekhtkaui, 116.
 Nekhtmin, 63.
 Nekhtnebf, 45.
 Nekhtnebf, 50.
 Nekht-pa-aten, 224.
 Nekhtre', 102.
 Nekhtusiri, 105.
 Nema'etrē' (Marres), 102.
 *Nemareth, son of Sesonchis I, 38, 121.
 Neni, 115.
 Nenkheftek, 123.
 Nenkheftka, 123.
 Nengi, 255, 256.
 Nes- , *see also* Es-
 Neshuy, 174, 175.
 Nesy (?), *see* Pepsyonb.
 Neternakht, 159.
 Neternakht, 162.
 Neternekhti, 162.
 Neternekhti, 162.
 Neteruhotp, 161.
 Neteruhotp, 238.
 Nī'ankh-Pepy (Khnemhotp-hepi), 132, 137-8.
 Nī'ankh-Pepy-kem (Sebk-hotp, Hebi-kem), 247.
 Nī'ankhsesi, 131.
 Ni-Pepy, 161.
 *Nofret, wife of Sesostris II, 18-19.
 Nubkaurē' . . . , 73.
 Onias, 57.
 Osiri-nakht, 39.
 Pa . . . , 34.
 Paakhut, 138-9.
 Pa-aten-em-hab, 228.
 Paēsi, 102.
 Pairi-kep (?) (Psammethemery-Neith), 64.
 Pakha, 227.
 Pamurē', 126.
 Panehesi, 196, 201, 201-2, 210, 218-19.
 *Para'messu, perhaps son of Sethos I, 114.
 Parē-em-hab, 63.
 Parē'hotp, 117.
 Parennufer, 219, 220, 221, 229.
 P-ar-kep, 48, 71.
 Pa-se, 232.
 Pautemhēt, 177.
 Pay, 113.
 Pazesef, 119.
 Pbes, 27, 39.
 Pdebhu, 47.
 Pedamenōpet, 7.
 Pedamenōpet, 256.
 Pedeamūn, 8.
 Pedeamūn, 37.
 Pedeamūn, 126.
 Pedeatum, 54.
 Pedeharphkredenēsi, 101.
 Pedehor, 47.
 Pedehor, 125.
 Pedehordeni, 75-6.
 Pedehor-meten (?), 67.
 Pedehor-pshenēsi, 102.
 Pedekakem, 174.
 Pedekem, 172.
 Pedemihōs, 38.
 Pedemin (?), 75.
 Pederpos, 33.
 Pedesemtu, 27.
 Pedesemtu, 36.
 Pedēsi, 101.
 Pedesobk, 102.
 Pedubaste, 95.
 Peduēsi, 241.
 Peduser-perē', 104.
 Pedusiri, 38.
 Pedusiri (Hor), 75-6.
 Pedusiri, 75-6.
 Pedusiri, 95.
 Pedusiri, 95.
 Pedusiri, 101.
 Pedusiri, 169-74, 174, 175.
 Pefteuamūn (Thaemhorimu), 65.
 Pefteu'arē', 86.
 Pefteu'au-Neith, 63, 71.
 Pemū, 37.
 *Pemū, son of Sesonchis III, 46.
 Pemū, 46.
 Pemū, 111.
 Penptah, 99.
 Penthu, 210, 217.
 Pepi, 254.
 Pepy'-ankh (Khui), 120, 125-6.
 Pepy'-ankh the eldest, 239, 240.
 Pepy'-ankh the youngest (Henī-kem), 247, 248, 249.
 Pepy'-ankh, 255.
 Pepy'-ankh, *see* Teti'-ankh.
 Pepy'-ankh-hir-ib (Neferka, Heny), 252, 254-5.
 Pepsyonb (Nesy ?), 245.
 *Per . . . , mother of 'A-seh-rē', 25.
 Pēre, 177.
 Per-her-nefert, 103.
 Peshedu, 113.
 Pesiūr, 23.
 Pesiūr, 117.
 Peter, 192.
 Pethenafi, 105.
 Pethenfi, 59, 64.
 Petisis, 124.
 Pewah, 205.
 *Philotera, daughter of Ptolemy I and Berenice, 6, 63.
 P-hont, 117.
 Piay, 58.
 Pikh'a's, 25.
 Pima (?), 111.
 Pipu, 39.
 Pkef (?), 95.
 Pkhar, 174.
 Psammethek, 8.
 Psammethek, 8.
 Psammethek, 46.
 Psammethek, 47.
 Psammethek, 48.
 Psammethek, 68.
 Psammethek, *see* Hor.
 Psammethek-menkh-ib, 8.
 Psammethek - mery - Neith, *see* Pairi-kep (?).
 Psammetheksonb, 47.
 Psammetheksonb, 51.

- Psammetheksonb, 270.
 Pshenehe, 54.
 Pshenehe, 256.
 Pshenptah, 3.
 Psherenmeht, 5.
 Psinesu, 96.
 Ptaḥmey, 10.
 Ptaḥmey, 209.
 [Ptaḥ]mey, 227.
 Ptaḥshepses (Impy), 255.
 Ptolemaea, 6.
 Ptomeh (?), 192.
 Puit, 268.
 Puu, 101.
 Puu, 111.
 Pwehemnūti, 125.

 Ra'mes-emperamūn, 113.
 Ra'meses-emperrē, 113.
 Ra'mosi, 5.
 Ra'mosi, 62.
 Ra'mosi, 118.
 Ra'mosi, 195.
 Ra'mosi, 204.
 Ra'mosi, 220, 224.
 Ramu-shenti, 159.
 Rē'ardais, 8.
 Redu, 209.
 Rē'-hem (Isi), 240, 243
 Rē'-hem, *see* Isi.
 Rē'-hēt, 65.
 Reḥi, 84.
 *Rē'hotp, son of Snefru,
 90-1.
 Rē'hotp, 117.
 Remeh, 89.
 Renef'ankh, 102.
 Renefsonb, 107.
 Renmest (?), 270.
 Rennūfer, 8.
 Rennut, 269.
 Renpetnefer(t), 174.
 Rē'nūfer (?), 92.
 Rē'nūfer, 205.
 Rerut, 256.
 Res, 114.
 Ry, 113.

 Saḥnūfer (Nebma'etrē'-
 nakht), 60.
 S'ankhptah-Pepy, *see* Sheshi.
 S'ankhy, 238.
 Sa(n)-user, 37.
 Sanwēse, 11.
 Sebeky, 61.
 Sebeky (By), 61.
 Sebkhotp, 68.
 Sebkhotp, 97.
 Sebkhotp, 104.
 Sebkhotp, 187.

 Sebkhotp, 237.
 Sebkhotp, 238.
 Sebkhotp, *see* Ni'ankh-Pepy-
 kem.
 Sebkhotpi, 162.
 Sebknakht, 62.
 Sebknakht, 247.
 Sebknakht-renfsonb, 98.
 Seheres, 268.
 Seḥetepebrē'-'ankh, 75.
 Seḥetepebrē'-'ankh, 80, 84.
 Seḥetep-thau (?), 81.
 Sekhmet, 111.
 Sekhmet-hotp, 68.
 Sekri, 90.
 Sel (?), 114.
 Semset, 37.
 Semtu-ardais, 139.
 Semtu-tefnakht, 46, 71, 119,
 121.
 Semtu-tefnakht, 121.
 Sen, 187.
 Sen, 187.
 Sen'ankh, 95.
 Sen'ankh, 257.
 Senbef, 75.
 Senbef, 75.
 Senbi, 249.
 Senbi, 248, 249-50, 250.
 Senbi, 248, 251.
 Senbi, 256.
 Senbi, 256.
 Senbi, 256.
 Senbi, 256.
 Senbi, 257.
 Senbi, 258.
 Senbi (Bakt), 259.
 Senbita, 83, 84.
 Senbsen, 246.
 Senbu, 163.
 Senebtisi, 78, 79, 81.
 Senebtisi, 105.
 Seneny, 107.
 Seni, 249.
 Senir, 86.
 Senkau (?), 268.
 Senmery, 87.
 Sennu, 256.
 Sennu, 257.
 Sennūfer, 185.
 Sennui, 256.
 Sennui, 257.
 Sen-rehui, 27.
 *Sent (Queen), 9.
 Sent, 79.
 Sent, 161.
 Sentuser, 267.
 Senusert, 75-6.
 Senusert, 85.
 Senusert, 87.

 Senusert, 110.
 Senusert, 112.
 Senusert-'ankh, 85.
 Senusert-'ankh, 105.
 Senusert-'ankh, 180.
 Senusert-'ankhitef (?), 112.
 Senusert-sonb, 87.
 Senwerui (?), 113.
 Sep, 181.
 Sep . . . (?), 238.
 Sepi I, 183.
 Sepi II, 183.
 Sepi III, 183.
 Sepi, 184.
 Sepi, 185.
 Sepi, 187.
 Ser, 238.
 Serfka (Urarna I), 186, 187-
 8, 188.
 Seruket, 107.
 Sesenbnef, 80, 84.
 Seshep-Min, 258.
 Sheshu, 171, 172, 173.
 Setekh-hirkhopshef, 10.
 Setemḥab, 119.
 Sethut (Tetit), 256.
 Sety, 23.
 Sety, 117.
 Setyerboni, 104.
 *Sety-Merneptah, son of
 Merneptah, afterwards
 Sethos II, 30, 167.
 Sety-nakht, 26.
 Sezefau, 94.
 Shbemmin, 44.
 Shebwi, 268.
 Shedesnefertem, 34.
 *Shedet-tefsi, 119
 Shedsumesu, 54.
 Shedu, *see* Iteti.
 Shems, 268.
 Shemsui, 269.
 Shemai, *see* Za'u.
 Shemsi, 184.
 Shepses, 86.
 Shepseskau, 137.
 Shepsu-heres, 269.
 Sheri, 202.
 Sheshi (Neferseshemseshet,
 S'ankhptah-Pepy), 62.
 *Sheshonḳ, afterwards Seson-
 chis I, 33.
 Sheshonḳ, 44.
 Shesmuhotp, 107.
 Si-ameny, 238.
 Si-i'oh, 95.
 Si-Isit, 269.
 Si-Isit, 269.
 *Sipaar, son of Amosis, 168,
 192.

- Sisobk, 48.
 Sisobk, 112.
 Sisobk, 267.
 *Sitamün, daughter of Amenophis III, 235.
 Sit'ankhu, 83, 84.
 Sit-Haremhet, 95.
 Sit-Hathor, 49.
 Sit-Hathor, 83, 84.
 *Sit-Hathor-int, 109-10.
 Sit-hez-hotp, 184.
 Sit-hez-hotp, 184-5.
 Sitimpi (?), 105.
 Sitipi, 183.
 Sit-Khonsu, 81.
 Sitmekut I, 83, 84.
 Sitmekut II, 83, 84.
 Sit-Mut, 95.
 Sit-rennut, 102.
 Siwazet, 87.
 Sutau, 227.
 Suti, 225.
- Ta-Amün, 102.
 Ta-Amün, 104.
 Tabam (?), 111.
 Tadepakem, 175.
 Ta(?)-ësi, 95.
 Tai, 267.
 'Taitha', 56.
 Takebto, 75.
 Tama, 115.
 Tasadi, 111.
 *Tashakheper, daughter of Osorkon II, 28.
 Tataia, 63.
 Tate (?), 111.
 *Tausert (Queen), 35.
 Tazab, 105.
 'Tazarti', 116.
 Tede, 258.
 *Tedubaste, mother of Osorkon, IV, 34.
 Tef-ibi, 260, 263.
 Tef-ibi, 267.
 Tefnakht, 37.
 Tefnakht, 47.
 Tefnakht, 50.
 Tehen, 171.
 Tekhyt, 246.
 Tekûshe, 33.
 Temtoneb, 34.
 Temtoneb, 35.
 Tenainüfer, 268.
 Tenro (Dor), 33.
 Tenro, 215.
 *Tent-ket[wa] (?), wife of Aupweth, 38.
 Tept, 257.
 Tere, 111.
- Terurë', 232.
 Teruru, 247.
 Teti, 238.
 Teti'-ankh (Imhōtep, Pepy'-ankh), 190, 191-2.
 Teti-ishtef, 36.
 Tetit, *see* Sethut.
 Tetu, 63.
 *Teye, wife of Amenophis III, 112, 113, 114, 115, 199, 201, 211, 212, 237; in titles, 211, 212.
 Teye, 175, 228, 229, 230.
 Tha, 269.
 Thaa, 163.
 Thaemhorimu, *see* Pefteu-amün.
 Thaipei (?), 205.
 Thau, 105.
 Thauau, 268.
 Thauau, 268.
 Thau (Anti-emhet), 161.
 Thay, 227.
 Thayt (?), 107.
 Thenti, 268.
 Thenti, 133.
 Thest(i)-Wehebrë', 62.
 *Thesubaste-perut, daughter of Osorkon II, 61.
 Theth, 62.
 Thetu, 256.
 Thetu, 256.
 Thiebendedemau, 36.
 Thiebendedemau, 37.
 Thonüfer, 64.
 Thoy, 59.
 Thoy, 268.
 *Ti'a, mother of Tuthmosis IV, and wife of Amenophis II, 99.
 Titau, 257.
 Tiuy (?), 107.
 *Tshenësi, mother (?) of Amasis, 42.
 *Tshenësi, probably wife of Petubastis (Neferkarë'), 121.
 Tshenkhons, 268.
 Tshentehe, 73.
 Tunubaste, 256.
 Tutu, 220, 221-2.
 Tuty, 115.
 *Tuy, wife of Sethos I, and mother of Ramesses II, 14, 19.
- Ukermen, 55.
 Ukh ('Aby), 256.
 Ukh'a, 257.
 Ukh-hotp, 249, 251.
- Ukh-hotp, 249.
 Ukh-hotp, 248, 250-1, 251.
 Ukh-hotp, 251.
 Ukh-hotp, 251, 252, 253.
 Ukh-hotp, 252, 253.
 Ukh-hotp, 253.
 Ukh-hotp, 256.
 Ukh-hotp, 256.
 Ukh-hotp, 256.
 Ukh-hotp, 257.
 Ukh-hotp, 257.
 Ukh-hotp, 257.
 Ukh-hotp, 257.
 Ukh-hotp, 257.
 Ukh-hotp, 257.
 Ukh-hotp, 257.
 Ukh-hotp, 257.
 Ukh-hotp, 257.
 Ukh-hotp, 258.
 Ukh-hotp, 258.
 Ukh-hotpi, 249.
 Ukh(t)hotp, 105.
 Unnüfer, 26.
 Unnüfer, 104.
 Unnüfer, 111.
 Unnüfer, 130.
 Unnüfer, 175.
 Urarna I, *see* Serfka.
 User, 259.
 Userhet, 162.
 Userhet, 26.
 Userhetai, 162.
 Useri, 162.
 Userma'etrë'-em-hab, 113.
 Userma'etrë'-nakht, 10.
 Userma'etrë'-nakht, 55.
 Uzaḥarmeḥent, 64.
 Uzaḥori, 32.
 Uzaḥor-shema'n, 54.
 Uzaḥor-shema'nt, 47.
 Uzaḥor-shema'nt (Neferebrë'-nebpehti), 49.
 *Uza-shu (Queen), 45.
- Wahka, 256.
 Wa'rt'ankh, 162.
 Wash-ka, 133.
 Wazet-hotp, 116.
 Wazkaues, 181.
 Weha, 246.
 Wehebrë', 5, 6, 47, 48.
 Wehebrë', 25.
 Wehebrë' . . ., 44.
 Wehem'az (?) (Wehemi) 136.
 Wehemi, *see* Wehem'az.
 Wehemka, 136.
 Wenamün, 175.
 Weni, 54.
 Wepay, 267.

Wepay, 267.
 Wepay, 268.
 Wepay, 268.
 Wepay, 269.
 Wepay, 269.
 Wepemy, 269.
 Wepty, 269.
 Wepu, 264.
 Weputemhēt, 268.
 Wepwaut, *see* Weriu.
 Wepwautemhēt, 265.
 Wepwautemhēt, 267.
 Wepwautemhēt, 268.
 Wepwautemhēt, 268.
 Wepwauthotp, 268.
 Wepwaut-nakhti, 267.
 Werirni, 186, 188, 188-9.
 Weriu (Wepwaut), 269.
 Wernüfer, 256.

Wersnüfer (probably same
 as last), 256.
 Wezebt, 86.
 Wiu (Yiu), 189, 190, 191.

Yewerhen, 111.
 Yiu, *see* Wiu.
 Yuny, 269.

Za'u (Shemai), 240, 244-6.
 Za'u, 244-6.
 Zedhutef'onkh, 171, 172,
 173, 174.
 Zedhutef'onkh, 269.
 Zefia . . ., 270.
 Zeh, 267.
 Zeḥo, 13.
 Zeḥo, 25.
 Zeḥo, 26.

Zeḥo, 59.
 Zeḥo, 95.
 Zeḥo, 172.
 Zeḥo, 172.
 Zeḥo-p-shed, 66.
 Zenetef'onkh, 55.
 Zen-wen, 69.
 Zeubastef'onkh, 33.
 Zeubastef'onkh, 102.
 Zeubastef'onkh, 125.
 * . . armer, daughter of Osor-
 kon II, 28.
 . . . bu-pemu (?), 95.
 . . . her . . ., 257.
 . . . ku, 96.
 . . . tirsunay, 57.
 . . . tseni, 256.
 . . . uky . . ., 185.

DIVINITIES INDEX

Amen-rē', 30, 31, 71, 74,
 127, 131, 164, 165, 167,
 176, 192; in titles, 26, 32,
 113, 268.
 Amen-rē' Kamutf, 264.
 Amūn, 14, 27, 34, 97, 129,
 130, 169, 209, 232, 241,
 264; in titles, 8, 34, 63,
 111, 127.
 'Ankh, 173.
 Anta, 53; temple of, 12,
 24-5.
 Anubis, 41, 74, 84, 127,
 130, 173, 212, 241, 269;
 in titles, 264.
 Apis-bull, 24.
 Arsenuphis, 34.
 Astarte, 74.
 Aten, 31, 63, 168, in 'Amarna,
 passim (192-237), 259;
 temples of, 195-7; in titles
 (*see also* Wa'enrē'), 89, 201,
 202, 205, 214, 217, 218,
 227, 235.
 Atum, 17, 53, 58, 71, 77,
 124, 173, 176; temple of,
 1, 55; in titles, 54, 62, 63.
 Ba'al, 53.
 Bubastis, 29, 30, 32, 34, 43,
 46, 58, 74; temple of, 33;
 in titles, 33, 34, 38, 55, 92.
 Buto, 7, 8, 24, 25, 26, 46,
 47, 74, 173; temple of, 8;
 in titles, 10, 65.

Castor, 130.

Demez, 173.
 Diana, 130.

Ennead, 164, 173; in titles,
 37, 251.
 Esenkhēbi, 97.

Geb, 173.

Hapi (*see also* Nile), 14, 173.
 Ḥar-Kentekhthai, in titles,
 66.

Ḥarmerty, temple of, 33.
 Harpocrates, in titles, 32.
 Harsaphes, 74, 115; tem-
 ple of, 118-19; in titles,
 116, 117.

Harsiēsi, 24.

Ḥathor, 6, 53, 74, 101, 127,
 129, 130, 165, 176, 269;
 temples of, 52, 53, 241;
 chapel of, 126-7; in titles,
 51, 123, 131, 138, 250,
 251, 254, 255, 257, 258,
 267.

Ḥathor-capitals, -emblems,
 -heads, 29, 35, 41, 127,
 241, 258.

Ḥathor-cow, 36.

Ḥat-meḥit, in titles, 37.

Ḥeḳa-ma-yotf, 173.

Hermes Trismegistos, *see*

Thoth.

Hesis (Isis-cow), 76.

Horus, 2, 5, 6, 21, 23, 33,
 36, 42, 46, 66, 73, 74, 103,
 118, 129, 130, 139, 165,
 173, 263, 269; temple of,
 53, 68; in titles, 47, 159.
 Horus, sons of, 139.
 Horus Khentenmerty, 173.
 Horus Smataui, 26.

Imset, 173.

Ir-renf-zesef, 173.

Isis, 23, 33, 39, 44, 46, 47,
 49, 74, 103, 124, 171, 173,
 176, 209, 241, 263; temple
 of, 2, 40-2, 176; in titles,
 73.

Isis-bark, 41.

Isis-cow, *see* Hesis.

Isis-Ḥathor, 76.

Ius-as, 176.

Kebḥsenuf, 173.

Kemwēr, 66.

Kentekhthai, 67, 74; in
 titles, 66.

Khepri, 17, 173, 176.

Khnum, 35, 130, 176; in
 titles, 86.

Khons, 27, 129; in titles,
 25.

Ma'et, 167; image of, 165,
 167, 176.

- Mati, 242.
 Mehit, 41.
 Mendes, 37; in titles, 13, 36, 37.
 Menkhetheb, 44.
 Merymutf, in titles, 259.
 Mihos, 38.
 Min, 8, 14, 24, 26, 99, 130, 241, 264; temple of, 7; in titles, 50, 92.
 Mnevis, 59, 60, 63.
 Monthu, 44; in titles, 10.
 Mut, 20, 27, 176, 232; temple of, 3.
- Neferhor, 75.
 Nefertem, 20, 270.
 Nehem'awat, 34, 37, 75, 176.
 Neith, 26, 35, 47, 48, 49, 72, 74; in titles, 35, 47, 101, 102.
 Nekhbet, 14, 28, 173; in titles, 65.
 Nekhen, souls of, 239.
 Nephthys, 41, 44, 103, 129, 139, 169, 173, 176, 241.
 Nepit (?), 55.
 Nile-god (*see also* Hapi), 17, 28, 30, 41, 43, 50, 82, 83, 99.
 'Noble of Hermopolis', 176.
 Nubite, in titles, 59.
 Nut, 40, 54, 172.
- Onuris, 38, 43, 45; in titles, 44, 45.
 Onuris-Shu, 43; temple of, 43.
- Osiris, 5, 6, 26, 27, 33, 39, 40, 41, 42, 44, 47, 59, 63, 74, 96, 103, 118, 121, 126, 127, 130, 139, 171, 172, 173, 176, 269; in titles, 47, 62, 262; Osiridestatues, 82.
 Osiris-Onnophris, 39, 40.
- Pa'kht, 164, 165, 176; in titles, 149, 174.
 Pe, souls of, 239.
 Petesuchos-Pnepherôs, temple of, 96.
 Pnepherôs (*see* Petesuchos-Pnepherôs), temple of, 98.
 Pollux, 130.
 Ptaḥ, 14, 17, 20, 21, 25, 26, 30, 31, 59, 74, 118, 127, 167, 176; in titles, 48, 75, 85, 268.
 Ptaḥ-Sokari-Osiris, temple of, 104.
- Rē', 30, 45, 53, 56, 204, 241, 264; bark of, 51; in titles, 60, 61, 63, 65, 205, 225.
 Rē'-Harakhti, 14, 17, 20, 38, 41, 53, 58, 61, 167, 177; in titles, 63.
 Reshef, 26.
- Sebk-rē', 131.
 Sekhmet, 3, 17, 23, 24, 25, 51, 129, 176; in titles, 48.
 Sekhmet-Hathor, temple of, 51.
 Serapis, temple of, 176.
 Serḳi, 173.
- Sēth, 8, 14, 18, 21, 23, 53, 55, 66, 69, 113.
 Sēth-nubti, 23.
 Shed, 209.
 Shesmetet, in titles, 92.
 Shu, 14, 31, 43, 67, 129, 165, 173.
 Sobk, 42, 74, 96, 101, 127, 129, 130; temple of, 98; in titles, 97, 127.
 Sokanobkoneus, temple of, 96.
 Sokari, 176.
 Sokari-Osiris, 169, 176.
 Soknopaios, temple of, 96-97.
 Sopt, 53, 74; temple of, 10-11; in titles, 11.
- Tefnut, 6, 173.
 Theban Triad, 26, 75.
 Thesy, 173.
 Thoth (*see also* Hermes Trismegistos), 34, 37, 39, 40, 44, 74, 75, 76, 99, 127, 129, 130, 164, 167, 168, 169, 171, 173, 175, 176, 185, 192, 241; temples of, 44, 165-7, 167; in titles, 40, 75, 169, 174, 175, 182, 238.
 Tuēris, 7, 46.
- Wa'enrē', *see* Aten; in titles, 225.
 Wepwaut, 74; in titles, 261, 262, 263, 264, 265.
 Wert-Ḥekau, 74.
 Wert-Ḥekau Pa'kht, 164.
- Yeb, in titles, 38.

GEOGRAPHICAL INDEX

The spelling followed is that of the Survey Maps of Egypt 1 : 100,000 scale.

Names in italics are Ancient Egyptian.

Names in capitals are Greek.

The article *el-* and the following descriptive words do not affect the alphabetical order of the place-names: *darb* 'track', *'ezba* 'farm', *kafr* 'village', *kôm* (*kéman*) 'mound', *nazla* 'hamlet', *tell* 'hill'. Thus Tell el-Aḥmar will be found under Aḥmar.

Museums are not included.

Aakemt, 242.

Abgig (Begig), 99, Map III.

el-Abqa'ain, Kôm, 50, Map I. B. 4.

Abû Billo, Kôm (TERENUTHIS), 67-8, Map

I. D. 5.

Abû el-Filûs, Tell, 9.

Abu-Kemt, 192.

Abû Qir (CANOPUS), 2, Map I. B. 2.

Abû Seifa, Tell, 6-7, Map I. J. 4.

Abû Shahba, Kafr, 123, Map IV.

Abû Šîr (BUSIRIS), 44, Map I. E. 4.

Abûšîr el-Malaq, 104-5, Maps II, III.

Abû Yâsin, 27, Map I. G. 4.

Abydos, 54, 268.

ACÔRIS, *see* Ṭihna.

Afrîn, Kôm, *see* Firîn.

- el-Aḥmar, el-Kôm, 132, 134-9, Map V.
 el-Aḥmar, Kôm, 67, Map I. E. 5.
 el-Aḥmar Sawâris, el-Kôm, 120, 125-6,
 Map IV.
 el-Aḥmar, Tell, 10, Map I. F. 5.
Akhetaten, in titles, 201, 202, 214, 217, 218,
 222, 224, 228; city of, 193-230, 233.
Akhwi, 126.
 Alexandria, 1, 2-6, 64, 65, 270, Map I. A. 2.
 el-'Amarna, 165, 169, 192-237, 239, Map V.
 el-'Âmiriyya, 6, Map I. A. 3.
 'Ammâr, Kafr, 85-6, Maps II, III.
Amt, 7.
 ANKYRONPOLIS (?), *see* Ḥiba.
 Antepolite nome, 242, 243, 244.
 ANTINOË or ANTINOUPOLIS, *see* Sheikh
 'Ibâda.
 APHRODITOPOLIS, *see* Aţfîḥ.
 el-'Aqârîb, Kôm, 119, 121.
 'Arab el-Borg, 246, Map V.
 'Arab el-Ṭawîl, 59.
 el-'Arîsh, 1, Map I. K. 3.
 ARSINOË, *see* Medînet el-Faiyûm.
 el-Ash'âr, Tell, 1, Map I. E. 1.
 Ashmûn, 67, Map I. D. 6.
 el-Ashmûnein (HERMOPOLIS MAGNA), 165-
 9, Map V.
 el-Asl, Kôm (BACCHIAS), or Umm el-Qaṭl,
 or Kôm el-Qaṭl, 96, Map III.
 Asyût (LYCOPOLIS), 239, 259-69, Map V;
 in titles, *see* *Sîût*.
 el-'Atâmna, 259, Map V.
 el-Atâwla, 246-7, Map V.
 Atef-nome, in titles, 250.
 Aţfîḥ (APHRODITOPOLIS), 75-6, Maps II, III.
 ATHRIBIS, 65, 66; in titles, 66; *see also*
 Atrîb.
 Atrîb, Tell (ATHRIBIS), 65-7, 70, Map I. E. 5.
 Aushîm, Kôm (KARANIS), 96, Map III.
 Ausîm (LETOPOLIS), 68, 72, Map I. E. 7.
 el-'Awâsga, 10, Map I. G. 5.

 BACCHIAS, *see* Asl.
 Bahbît, 42, 73.
 Bahbît el-Ḥigâra (ISEUM), 40-2, Map I. E. 3.
 el-Bahnasa (OXYRHYNCHUS), 124, Map IV.
 Bahtîm, 58-9.
 Balala, Tell (Tell 'Tebilla'), 39, Map I. G. 3.
 Balanşûra, 165, Map V.
 Balţîm, 1, Map I. E. 1.
 Bânûb, 42, Map I. E. 3.
 Baqlîya, Tell (HERMOPOLIS PARVA), 36,
 39-40, 72, Map I. F. 3.
 el-Barâd'a, 65, 67, Map I. E. 6.
 el-Barnûgi, 49, Map I. C. 3.
 Bashkatîb, 108, 111.
 Basta, Tell (BUBASTIS), 27-35, 39, 44,
 Map I. F. 5.
 Baṭn Iḥrît (THEADELPHIA), 98, Map III.

 Bâwîṭ, 194.
 Begîg, *see* Abgîg.
 Benha, 59, 65-7, Map I. E. 5.
 Beni Hasan, 104, 135, 140-63, 165, 180,
 Map V.
 Beni Ḥasan el-Shurûq, 163, Map V.
 Beni Qurra, 241, Map V.
 Bilbeis, 11, 55-6, Map I. F. 5.
 Bilgâi, 40, Map I. F. 3.
 el-Bindariya, 46, Map I. D. 4.
 el-Birka, Tell, 9, Map I. G. 4.
 Birket Qârûn, Map III.
 Bişra, 247, Map V.
 Bitter Lakes, 52, Map I. J-K. 6.
 Biyahmu, 98, Map III.
 BUBASTIS, *see* Basta; in titles, 67.
 el-Bûha, 39, Map I. E. 4.
 Bûlâq, *see under* Cairo.
 BUSIRIS, *see* Abû Şîr.
 BUTO, *see* Farâ'in; in titles, 45.

 Cairo, 11, 44, 48, 49, 51, 55, 57, 67, 68,
 69-73, 74, 234, 235, Maps I. E. 7, II;
 'Atfet el-Biraqdar, 70;
 'Atfet el-Khayashi, 69;
 Bâb el-Bahr, 70;
 Bâb el-Futûḥ, 69, 70;
 Bâb Zuwêla, 70;
 Bûlâq, 72, 73;
 Citadel, 69, 70, 71, 72, 73;
 Darb el-Asfar, 69;
 Ezbekîya, 71;
 Haret el-Rum, 69;
Mosques:
 Amîr Khûr, 73;
 el-Ashraf, 73;
 el-Azhâr, 69, 72;
 Bèbars Gashinkîr, 71;
 el-Dardîr, 72;
 el-Ghamri, 71;
 Ibn Tulûn, 72;
 Kikhya, 71;
 el-Mu'aiyad, 69;
 Salahdar, 70;
 Sangar el-Gâuli, 72;
 Sheikhûn, 49, 73;
 Sidi el-Belkeni, 71;
 Sultân-Ḥasan, 72;
 el-Turkemâni, 70;
 Qanṭara el-Gedîda, 71;
 Qaşr el-'Aini, 73;
 Qaşr el-Dubâra, 69;
 Saida Zenab, 72;
 Shâri' Abdîn, 71;
 Shâri' Abu-Lifa, 70;
 Shâri' Amîr el-Giyûsh, 71;
 Shâri' Bein el-Sayârig, 71;
 Shâri' el-Gamâlîya, 69;
 Shâri' el-Khurunfish, 71;

- Cairo, Shâri' Wagh el-Birka, 71 ;
 Sûq el-Sâlah, 68, 72.
 (For Old Cairo, *see* Fustât.)
 CANOPUS, *see* Abû Qîr; decree of, 15, 51,
 73.
 CLYSMA, *see* Qulzûm.
 Cremona, 234.
 CROCODILOPOLIS-ARSINOË, *see* Medînet el-
 Faiyûm.
 CUSAE, 251; in titles, 250, 251, 254; *see*
also Qû:îya.
- Dafana, Tell (DAPHNAE), 7, Map I. H. 4.
 Dahshûr, 123.
 Dairût, 194.
 Damanhûr, 26, 49, Map I. C. 3; stela of,
 49, 50.
 Damietta, 1, 2, Map I. G. 2.
 DAPHNAE, *see* Dafana.
 Dara, 258, Map V.
 Deir el-Amîr Tâdros, 241, Map V.
 Deir el-Bersha, 177-85, 187, 194, 238, 247,
 Map V.
 Deir Durunka, 259, 269-70, Map V.
 Deir el-Gabrâwi, 240, 242-6, Map V.
 Delta, 1-73, 168, Map I.
 el-Didâmûn, 9, Map I. C. 4.
 Dikiris, 39, Map I. G. 3.
 Dimai (ΣΟΚΝΟΠΑΙΟΥ ΝΗΣΟΣ), 96-7, Map III.
 el-Dimeiyîn, 10, Map I. G. 5.
 Dimishqîn, 108, 111.
 el-Dinnâwiya, 77, Map II.
 Dirwa, 169, 194, Map V.
 Dishâsha, 120, 121-3, Map IV.
 el-Dosha, Kôm, 67.
 Dundîf, 39, Map I. E. 4.
 Duqmeira, 42, Map I. E. 3.
- Edfu, 42.
 Elephantine, 71.
- el-Faiyûm, 74, 96-104, Map III; goddesses
 of, 101; in titles, 97, 102, 104.
 Fâqus, 9-10, Map I. G. 4.
 el-Farâ'in, Tell, or Ibtu (BUTO), 45, Map I.
 D. 3.
 Faramâ, Tell (PELUSIUM), 1, Map I. K. 3.
 Fâris, Kîman, 98-9.
 Far'ûn, Tell, *see* Nabêsha.
 el-Fashn, 124, Map IV.
 Firin, Kôm (Kôm Afrîn), 50-1, Map I. C. 4.
 Fort 'Taufiq, 2.
 el-Fustât (Old Cairo), 69, 70, 71, 73.
- el-Gamhûd, 124, Map IV.
 Ganâg, 49, 71, Map I. D. 3.
 Gebel Abû Fôda, 241, Map V.
 Gebel Abû Hassa, 53, Map I. J. 7.
 el-Gebel el-Ahmar, 65, Map I. F. 7.
 Gebel Murr, 53, Map I. J. 7.
- Gebel el-Rûs, 103, Map III.
 Gebel el-Teir, 120, 127, Map IV.
 Ghîta (Tell Yehud), 56, Map I. F. 6.
 Gî'eif, Kôm, *see* NAUCRATIS.
 Gireis, 67, Map I. D. 6.
 el-Girza, 86-7, 89, Maps II, III.
 el-Gîza, 69, 91.
 Gumaiyima, 9.
 'Gurob', *see* Medînet Ghurab.
- el-Hagg Qandîl, 194.
 el-Hamzaouï, Darb, *see* Wâdi Abû Hâshâh
 el-Bahri.
 el-Haraga, 105, 107, Maps II, III.
 Hare-nome, in titles, 177, 179, 181, 182,
 183, 187, 189, 237, 238.
Hat-khas, 39.
 Hauwâret el-Maqta', *see* Hawâra.
 Hawâra (Hauwâret el-Maqta'), 100-3,
 Map III.
 el-Hawata, 194.
 HELIOPOLIS, 2, 3, 4, 5, 57, 58, 59-65, 67,
 69, 70, 71, Map I. F. 7; in titles (*see also*
 On), 59, 62, 73, 84, 90.
 'HELIOPOLITAN LEONTOPOPOLIS', *see* Yahû-
 diya.
 Helwân, 73.
 HERACLEOPOLIS MAGNA, *see* Ihnâsya el-
 Medîna; in titles, 3, 121, 123.
 Hermonthite nome, in titles, 9.
 HERMOPOLIS MAGNA, 168; necropolis of,
 169-75; *see also* Ashmûnein.
 HERMOPOLIS PARVA, *see* Baqlîya.
 Hermopolis, noble of, *see* Divinities Index
 Hermopolite nome, in titles, 174.
 Het-nub, 192, 194, 237-9, Map V.
 el-Hîba (ANKYRONPOLIS?), 124-5, Map IV.
 el-Hî:n, Kôm, 51-2, Map I. C. 4.
 Hî:n, Tell, 59, 60-2, Map I. F. 7.
 Hurbeit (PHARBAETHOS), 26-7, 34, 37, 39,
 Map I. C. 4.
- Ibn Salâm, Tell, *see* Timai.
 Ibsân, Kôm, 45, Map I. E. 3.
 Ibtu, *see* Farâ'in.
 Idku, 2, Map I. B. 2.
 Ihnâsya el-Medîna (HERACLEOPOLIS MAG-
 NA), 118-19, 121, 123, Maps II, III, IV.
 el-Imariya, 194.
 ISEUM, *see* Bahbît el-Higâra.
 Isma'ilia, 6, 52, 53, 54, Map I. J. 5.
 Iṣṭabl 'Antar, near Cairo, 73, Maps I. E. 7,
 II.
 Iṣṭabl 'Antar (SPEOS ARTEMIDOS), 150, 163-
 5, Map V.
 'Iṣṭabl 'Antar', at Asyût, 261.
- el-Kabrit, 52, Map I. K. 6.
 Kahûn, 108, 110, 111-12.
 el-Karaïb, Darb, 241.

- KARANIS, *see* Aushîm.
 Karnak, 3.
 Kawâdi, Tell, 48.
 el-Kebîr, el-Tell, 52, 55, Map I. G. 5.
Kemwêr, in titles, 66.
 Kerma, 262.
 el-Khânka, 58, Map I. F. 6.
 Khatâ'na, 9, Map I. G. 4.
Kha'y, in titles, 259.
 el-Khuşûş, 59-60, Map I. F. 6.
 Kurûm el-Tuwâl, 6, Map I. A. 3.
Kush, in titles, 31, 32.
 el-Kuwalla, Kôm, 45.
- el-Lâhûn, 106, 107-112, Maps II, III.
 LEONTOPOLIS, *see* Muqdâm and Yahûdiya.
 LETOPOLIS, 67; *see also* Ausîm.
 el-Lisht, 77-85, Maps II, III.
 LYCOPOLIS, *see* Asyût.
 Lycopolite nome, in titles, 261, 262, 263, 264.
- el-Ma'abda, 241, Map V.
Mafek, 53.
 el-Maḥalla el-Kubra, 42, Map I. E. 3.
 Maḥallet Marḥûm, 46, Map I. D. 4.
 Maidûm, 74, 88, 89-96, Maps II, III; in titles, 89.
 Maiyâna, 115, Maps II, III, IV.
 el-Makhzan, Tell, 1.
 Mallawi, 169, 175, 194, Map V.
 Manâqir, Kafr, 67.
 Manfalût, 258, Map V.
 Manqabâd, 239, 259, Map V.
 Manshiyet el-Sadr, 62, Map I. F. 7.
 MAREOTIS, *see* Maryût.
 el-Marg, 59, Map I. F. 6.
Maru-Aten, 194, 208.
 Maryût, Lake (MAREOTIS), 6, Map I. A. 3.
 Ma'sara, 45, Map I. F. 2.
 el-Ma'sara, 74-5, Map II.
 el-Maskhûṭa, Tell (PITHOM), 52, 53-5, Map I. H. 5.
 Masra', 259, Map V.
 Maṭariya, 13, Map I. H. 3.
 el-Maṭariya, 62, 270, Map I. F. 7.
 Matbûl, Kafr, 45, Map I. E. 3.
 Mazghûna, 76-7, Map II.
 Medînet el-Faiyûm (CROCODILOPOLIS-ARSINOË), 73, 98-9, Maps II, III.
 Medînet Ghurab, Kôm ('Gurob'), 112-15, Maps II, III.
 Medînet Qûta (el-Yaûta), 97, Map III.
 Meir, 247-58, Map V.
 Memphis, 10, 59, 60, 64, 69, 70, 71, 72; in titles, 85.
Menat-Khufu, in titles, 144, 149, 159.
 MENDES, 35-7; in titles, 39; *see also* Rub'.
Mesen, 6.
 Minshât Sulimân, 75.
- Minûf, 72, Map I. D. 5.
 el-Minya, near Cairo, 75, Map II.
 el-Minya, 133, 139, Maps IV, V.
 Mît Fâris, 99.
 Mît Gharîṭa, 37, Map I. F. 4.
 Mît Ya'ish, 39, Map I. F. 5.
 el-Munâgât el-Kubra, 7, Map I. H. 4.
 el-Muqdâm, Tell (LEONTOPOLIS), 35, 37-9, Map I. F. 4.
 Muştâi, Map I. E. 5.
 Mustâi, Tell (Kôm el-Mustein), *see* Umm Ḥarb.
 Musturud, 58-9, Map I. E. 6.
- Nabêsha (Tell Far'un), 7-9, Map I. G. 4.
 el-Nahḥâriya, 49, Map I. D. 4.
 el-Naqûs, Tell, 39-40.
 NAUCRATIS (Kôm Gi'eif, el-Nibeira, el-Niqrâsh), 50, 51, Map I. C. 4.
Neferus, in titles, 165.
Nekhen, in titles, 159, 160; souls of, *see* Divinities Index.
 el-Nibeira, *see* NAUCRATIS.
 el-Niqrâsh, *see* NAUCRATIS.
 Nûb Taḥa, 58, Map I. F. 6.
 Nuêrât, 163.
- Old Cairo, *see* Fustât.
 On (HELIOPOLIS), in titles, 59, 61, 62, 225.
 Oryx-nome, in titles, 136, 141, 149, 151, 154, 159, 160.
 OXYRHYNCHUS, *see* Bahnasa.
- Pakhnamunis*, in titles, 32.
 Palermo, Stone of, 133.
 PELUSIUM, *see* Faramâ.
Per-nesu, 10.
Peru-nûfer, 30.
 PHACUSA, *see* Şaṭt el-Ḥinna.
 PHARBAETHOS, *see* Hurbeit.
 PITHOM, *see* Maskhûṭa; in titles, 53.
P-mek, 174; in titles, 174.
 Port Sa'id, 6, 7, Map I. J. 2.
- Qaha, 67, Map I. E. 6.
 el-Qanṭara, 6-7, Map I. J. 4.
 Qantîr, 9-10, Map I. G. 4.
 Qaşr el-Sâgha, 97, Map III.
 Qaşr Qârûn, 97, Map III.
 el-Qaṭl, Kôm, *see* Asl.
 el-Qaṭṭa, 68, Map I. D. 6.
 el-Qirqafa, Tell, 9.
 Qubbet Taufîq, 62, Map I. F. 7.
 el-Qulzum, Kôm (CLYSMA), 52.
 Qurna, 156.
 Quşeir el-Amarna, 239-41, Map V.
 el-Qûşîya (CUSAE), 258, Map V.
- el-Ratâba, Tell, 55, Map I. H. 5.
 el-Rebâi'în (Rebai), 27, Map I. G. 4.

- Red Sea, 52, 53, Map I. K. 7.
Rē-nūfer, 39.
 'Reramoun', 70.
 el-Riqqa, 86-7, 89, Maps II, III.
 Roda, Island of, 70.
 Rome, 63.
 Rosetta, 1-2, Map I. C. 2; decree of, 58;
 Stone, 1, 50.
 el-Rub', Tell (MENDES), 35-6, 36, 39,
 Map I. F. 3.
- Şâ el-Ḥagar (SAÏS), 46-9, 71, Map I. D. 3.
 Şaft el-Ḥinna (PHACUSA), 6, 10-11, 13,
 Map I. G. 5.
 Saïs (see also Şâ el-Ḥagar), 49, 63; in titles,
 47, 48, 51.
 Sakha (Xoïs), 45, Map I. D. 3.
 Sala, Nazlet, 126.
 Şamad, Tell, 55, Map I. H. 5.
 Samannûd (SEBENNYTOS), 41, 43-4, Map I.
 E. 3.
 Şân el-Ḥagar (TANIS), 12, 13-26, 69, Map
 I. G. 3.
 Şaqqâra, 36.
 Sawâris, see Aḥmar.
Sebat, in titles, 94.
 SEBENNYTOS, see Samannûd.
Sehetep-Aten, in titles, 195, 225.
 Seila, 103, Map III.
 el-Shaghâmba, 56, Map I. F. 5.
 el-Shallûfa, 52, Map I. K. 7.
 Shârûna, 125, 126, Map IV.
 el-Shatâyîn, Kôm, 43, Map I. E. 3.
 Sheikh Abêd, 59.
 Sheikh 'Atîya, 239, Map V.
 el-Sheikh Fadl, 126, Map IV.
 el-Sheikh 'Ibâda (ANTINOË or ANTINOU-
 POLIS), 170, 175-7, Map V.
 Sheikh Mubârik, 133, Maps IV, V.
 Sheikh Raziq, Kôm, 10, Map I. G. 4.
 el-Sheikh Sa'id, 165, 187-92, 194, Map V.
 Sheikh Zibeida, 192.
She-Sobb, 97.
 Shibîn el-Qanâtîr, 58, Map I. F. 6.
 el-Shôbak, 58, Map I. F. 6.
 el-Shurafa, 75, Map II.
 el-Shurafa, Nazlet, 133, Maps IV, V.
 Sîdi Abû el-Nûr, 'Ezbet, 88, 95.
 Sîdi (?) Mûsa, Kafr, 68.
 Sidmant (el-Gebel), 115-18, Maps II, III,
 IV.
 el-Simbillâwein, 37, Map I. F. 4.
 el-Sirîriya, 120, 126-7, Map IV.
 Siryâqûs, 58, Map I. F. 6.
Sîit, in titles, 261.
Smen-Ḥôr, in titles, 86.
 SOKNOPAIΟΥ NĒSOS, see Dimai.
 SPEOS ARTEMIDOS, see Istaḅl 'Antar.
 Succoth, see *Theku*
 Suez, 52, 73, Map I. K. 7.
- Ṭaḥta, 127.
 'Talklia' (Talkhâ?), 42.
 Ṭambûl, Tell, 37, Map I. F. 4.
 ṬANIS, 39, 49, 270; in titles, 25; see also
 Şân el-Ḥagar.
 ṬANIS SUPERIOR, see Tûna.
 Ṭanta, 41, 45, Map I. E. 4.
 Ṭarkhân, 85-6, Maps II, III.
 el-Ṭatâliya, 258, Map V.
 el-Ṭawîla, 10, 55, Map I. G. 5.
 'Tebilla', Tell, see Balala.
 TEBTUNIS, see Umm el-Breigât.
 TĒNIS, see Ṭihna.
 Tennis, Tell, 13, Map I. J. 2.
 TERNUTHIS (see also Abû Billo), 6.
Teuzoi, 124.
Tharu, 6.
 THEADELPHIA, see Baṭn Ihrî.
 Thebes, 135, 145, 146.
Theku (Succoth), in titles, 53, 54, 55.
 THMUIS, see Timai.
 Tîda, 45, Map I. D. 2
 Ṭihna (TĒNIS or ACŌRIS), 127-33, Maps IV,
 V; in titles, 131.
 el-Till, 70, 194, 198, 207.
 Timai, Tell, or Tell Ibn Salâm (THMUIS),
 35, 36, Map I. F. 3.
 Timai el-Amdîd, 35-7, Map I. F. 3.
 Ṭôd, 19.
 Ṭûkh el-Malaq, 67, Map I. E. 6.
 Ṭûkh el-Qarâmûs, 27, Map I. G. 5.
 Tûna (TANIS SUPERIOR), 169-75, Map V.
 Tûna el-Gebel, 194, 230.
Tunip, 67.
 Ṭura, 74, 75, Map II.
- Umm el-Ab, Tell, 45.
 Umm el-Breigât, Tell (TEBTUNIS), 103,
 Map III.
 Umm Ḥarb, Tell, or Tell Muştâi, 44, Map
 I. E. 5.
 Umm el-Qaṭl, see Asl.
- Wâdi Abû Ḥaşâh el-Baḥri (Darb el-Hamza-
 ouï), 194, 235.
 Wâdi el-'Anqabîya el-Rawyâna, 73.
 Wâdi Magberi, 241.
 Wâdi Tummilât, 52, 53-5, Map I. G.-J. 5.
 Wardân, 68, Map I. D. 6.
- Xoïs, see Sakha.
- el-Yahûdiya, Tell ('HELIOPOLITAN LEONTO-
 POLIS'), 56-8, Map I. F. 6.
 el-Yaûta, see Medinet Qûta.
Yebt-Ḥor, in titles, 38.
 Yehud, Tell, see Ghîta.
 'Yetwal wa Yeksar, Kôm', 45.
- el-Zaqâziq, 30, 32-5, Map I. F. 5.

- | | |
|---|-------------------------------------|
| Zâwyet el-Amwât (el-Maiyitin), 104, 134-9,
Maps IV, V. | Zâwyet Razîn, 67, Map I. E. 6. |
| Zâwyet el-Maiyitin, <i>see</i> Zâwyet el-Amwât. | el-Zeitûn, 'Ezbet, 62, Map I. F. 7. |
| | Zifta, 39, 44, Map I. E. 4. |

VARIOUS

- | | |
|---------------------------|---------------------------|
| Bull-Cemetery, 59-60. | Pompey's Pillar, 3. |
| 'Cleopatra's Needles', 4. | Ram-Cemetery, 36. |
| Crocodile-Cemetery, 102. | 'Satrap's Stela', 49, 73. |
| 'Fraser Tombs', 131-2. | 'Wilbour Stela', 236. |
| 'Metternich Stela', 5. | |