

### Abstract

Prop-Fan technology readiness is approaching the industry. Analytical and experimental scale model test results have provided verification of single rotation aeroacoustic performance and design techniques. A large scale rotor technology program is underway to verify the swept blade structure. This success has led to interest in counter rotation concepts. Initial evaluations show advantages of counter rotation are significant in terms of fuel savings and operating costs when compared to single rotation. Technology programs are being expanded to verify the counter rotation evaluations and put the key and unique design tools in place. This paper describes single and counter rotation Prop-Fan configurations for both tractor and pusher applications. The necessary technology programs are discussed and trade study results for a typical short range commercial transport are presented.

### I Introduction and Background

In 1975, NASA-Lewis initiated research activity on a high speed propeller concept proposed by Hamilton Standard, a division of United Technologies. This concept, called the Prop-Fan, has emerged as a fuel conservative competitor to the high bypass ratio turbofan in powering short range commercial transport applications. The potential fuel and operating cost benefits of the Prop-Fan has created new interest in propeller technology development. Prop-Fan technology readiness is fast approaching the industry. With successful accomplishment of scheduled technology readiness testing, the design and development of a single rotation (SR) Prop-Fan propulsion system like that shown in Figure 1 could start in 1987.

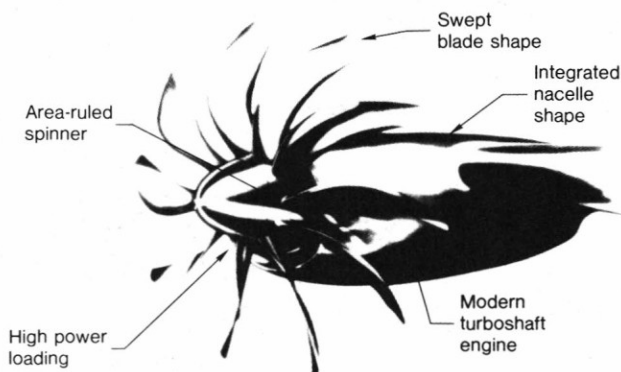

Figure 1. Single Rotation Prop-Fan Propulsion System

Analytical studies and experimental model tests conducted over the last nine years have provided verification of aerodynamic and acoustic performance as well as key design techniques for SR Prop-Fan concepts. Complimentary studies by engine and airframe manufacturers, with Prop-Fan data supplied by Hamilton Standard (Ref. 1 and 2), have indicated that aircraft powered by geared SR Prop-Fan propulsion systems could save about 20 percent in fuel burned and 10 percent in direct operating costs relative to a comparable technology turbofan powered aircraft (Ref. 3, 4, 5 and 6).

Major technical progress made to date includes the following.

- o Single rotation propeller efficiencies demonstrated above 80 percent at 0.7-0.8 Mn cruise.
- o Significant aeroacoustic benefits attributed to thin, swept blades.
- o Wing tailoring has resulted in swirl recovery.
- o Good tractor inlet performance demonstrated.
- o Confidence achieved in prediction of source noise levels.
- o Experimental verification of structural design tools achieved.

Among the key concerns remaining are Prop-Fan swept blade structural integrity and cabin comfort. These concerns can be adequately addressed only through large scale flight testing which evaluates blade forced response, blade flutter, and cabin noise and vibration. Large scale in this case is 8 to 9 feet (~3 meters) in fan diameter, the size required to confidently maintain structural similarity with full scale of 12-18 feet (~4-6 meters). A NASA-sponsored Large Scale Advanced Prop-Fan (LAP) rotor technology program is presently underway to verify structural adequacy. The large scale advanced Prop-Fan, presently being manufactured, will be tested in a static whirl rig and in a high speed wind tunnel. A scale replica of the Prop-Fan used for the LAP program is shown in Figure 2.

NASA plans to initiate a Prop-Fan Test Assessment (PTA) program in 1984. Under this program, the LAP rotor will be coupled with a modified Allison gas turbine and gearbox and subjected to engine static and wind tunnel tests as well as installation on a demonstrator aircraft for ground testing and the option of flight tests in 1987. Results from these tests should resolve the remaining technical issues for SR Prop-Fans. This program, in conjunction with successful completion of other technology readiness testing, can allow commercial development to begin in 1987.

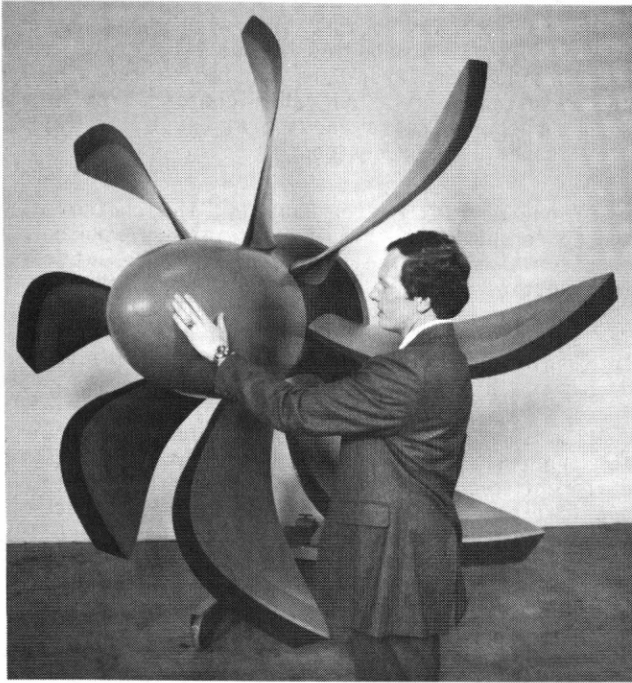

Figure 2. Scale Replica of Prop-Fan Used for the Large Scale Advanced Prop-Fan Program

Although the Prop-Fan is lightly loaded in relation to a high bypass ratio turbofan, it is highly loaded in relation to today's three- and four-bladed propellers designed for lower flight speeds. The turbofan has the smallest diameter and imparts the highest swirl velocity to the airstream. The swirl from the turbofan rotor is turned to the axial direction by a downstream row of stator vanes. The lightly loaded three- and four-bladed conventional propellers used in low speed aircraft have the largest diameters and do not impart high swirl velocities. The SR Prop-Fan falls between the turbofan and the conventional propeller in both size and slip stream swirl energy. Analytical studies have shown full recovery of the swirl energy could be achieved through employment of a counter rotation (CR) Prop-Fan system. This could improve the design point cruise efficiency by about 8 efficiency points at high subsonic cruise (0.7-0.8 Mn). This potential for increased efficiency and fuel savings was the main impetus of a NASA-funded study conducted in 1982 for CR Prop-Fans (Ref. 5). The CR Prop-Fan propulsion concept and resultant benefits compared to SR are shown in Figure 3. Aircraft mission analysis results showed 9% less fuel burned and nearly 3% lower operating cost for CR over that of the baseline ten-bladed SR Prop-Fan. The study aircraft was a 100 passenger commercial transport designed for 1300 nautical miles (NM), operating on a 400 NM typical mission at 0.8 Mn cruise with 60 percent payload. Other industry studies for cruise Mach numbers between 0.7 and 0.8 have shown similar benefits for CR Prop-Fans. These encouraging results have spawned new activity to configure CR Prop-Fan propulsion systems and to schedule development of associated technologies on a timeframe similar to SR.

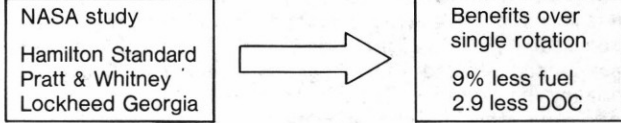
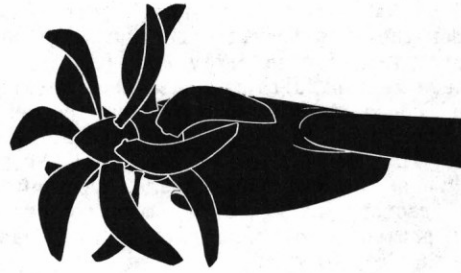

Figure 3. Counter Rotation Prop-Fan Study Results

## II Propulsion System Configurations

There are many choices available to engine and aircraft designers for future Prop-Fan powered aircraft. These include:

- SR or CR Prop-Fans
- Wing or fuselage mounted installations
- Tractor or pusher configurations
- Geared or gearless engines

Much more study and testing remains before the designers can finally determine the differences between the various combinations. Each of the various combinations has potential advantages and problem areas which are discussed below. The combinations creating most interest today are SR and CR geared tractors on the wing, CR mounted aft in a geared tractor or pusher configuration, and a CR gearless aft mounted pusher system. Figure 4 shows two of the most prominent combinations.

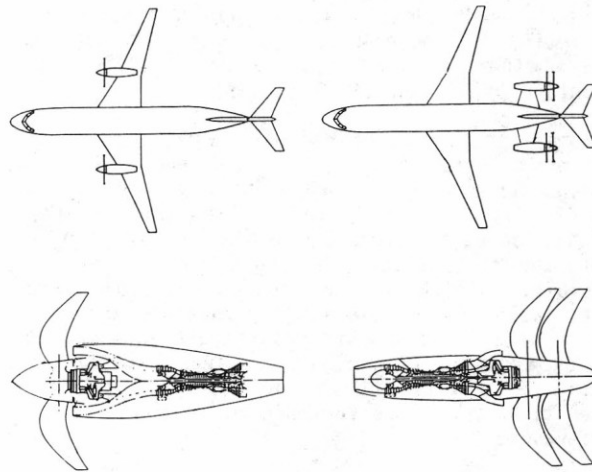

Figure 4. Typical Wing- and Aft-Mounted Prop-Fan Installations

Based on NASA Ames wind tunnel test results, a SR under-the-wing tractor configuration may be most appropriate for an early Prop-Fan installation. These test results indicate that a tailored wing can reduce the exit swirl flow inherent in the SR Prop-Fan system, resulting in better performance. It also suggests that a CR Prop-Fan system, when tested in the same type of wing mounted tractor installation, may not realize the full projected 8 point efficiency advantage over the SR Prop-Fan. As discussed earlier, a SR Prop-Fan propulsion system will be installed on an aircraft in a wing mounted tractor configuration for 1987 flight testing under the NASA-sponsored LAP and PTA programs. Lockheed Georgia Company has been selected for the NASA PTA program and the flight aircraft will be a Gulfstream II.

Tractor configurations mounted on the wing have been traditional for past turbo-prop installations. A positive aspect of this installation is the blown wing effect and the resultant good low speed aircraft performance. Future military tactical aircraft with STOL requirements will likely favor tractor wing mounted installations. Another positive aspect of tractor configurations is the cleanliness of the flowfield into the Prop-Fan. This results in lower acoustic levels and blade structural loads when compared to pusher configurations. A negative aspect of wing mounting is the added fuselage acoustic attenuation treatment required to achieve acceptable cabin comfort for commercial aircraft.

Despite noteworthy technical progress, many technical questions remain to be resolved for both SR and CR. The unique aspect of CR is the interaction of the two blade rows and the effect this interaction will have on aerodynamics, noise generation, and structural excitation. Model test programs are planned for CR blading in 1984 to address these questions. Model aircraft installation tests are also scheduled for both pusher and tractor applications. Upon completion of these tests, a judgement can be made whether the projected 8 point efficiency advantage of CR over SR is realistic.

Some industry experts are favoring configurations mounted aft on the fuselage. The key reasons for moving the Prop-Fan from the wing to the aft fuselage are 1) to position the Prop-Fan and its acoustic signature behind the passenger cabin and 2) to allow the wing to be as clean as possible. Airframe industry studies indicate that viable solutions exist for fuselage acoustic treatment and model tests results are encouraging for SR tractors with tailored wings. Therefore, moving SR systems aft may be desirable only if these acoustic or performance solutions are not achievable.

On the other hand, CR Prop-Fans, with little or no swirl in their slipstream, may be better suited for aft mounted commercial installations. As stated before, aft mounted configurations with the Prop-Fans behind the passenger compartment, may save the weight penalty from the fuselage acoustic treatment of wing installations.

However, Prop-Fans located aft, with their sound pressure levels around 150 dB, will be closer to the fuselage than Prop-Fans located on the wing. The resultant effect on cabin comfort from the structure borne noise and vibration in the tail area is not well understood.

If one moves the Prop-Fan aft, the choice of tractor or pusher becomes more meaningful. Pusher configurations on the wing are probably out of the question because of the strong wing wake and its structural loading on thin Prop-Fan blades. The aircraft designer must conduct trade studies to quantify the differences between CR tractors or pushers aft on the fuselage.

From a propulsion system standpoint, the tractor and pusher configurations present distinctly different technical challenges. For the tractor application, the Prop-Fan has clean air approaching and the engine designer is concerned over 1) the effect of the exit swirl flow from the Prop-Fan on the propulsion system inlet, whether it be single chin, dual chin, or annular, 2) the back pressure effect of the inlet on the Prop-Fan, 3) the pressure recovery in the diffuser ducting to the compressor front face, and 4) the level of distortion provided at the compressor front face. For the pusher application, management of the hot exhaust stream air through or around the Prop-Fan is a concern. Potential solutions include a forced mixer to cool the engine exhaust flow, advanced blade materials for the Prop-Fan, or ducting the engine exhaust air through the center of the engine afterbody. Another pusher installation concern is the effect of the pylon flow on the Prop-Fan aerodynamics, acoustics, and structural excitation.

Another potential CR pusher system is a direct drive configuration which eliminates the gearbox. One such system features a multi-stage low speed CR power turbine directly connected to the CR Prop-Fans. Figure 5 shows this type of system in a pusher application because it would be much harder to configure this direct drive system, with its four separate rotors, in a tractor application. This concept is discussed in more detail later in the paper.

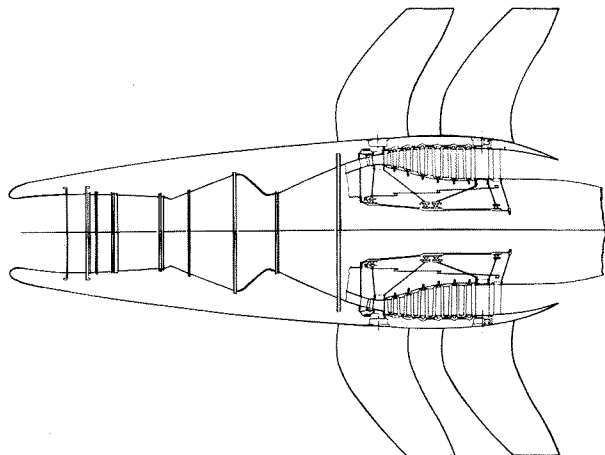

Figure 5. Gearless Turbine Engine

On the other hand, the use of a gearbox permits the design of a high speed turbine and a low speed lightly loaded Prop-Fan to maximize the performance of both components. A comparison of the performance and economics of direct drive and geared systems is made in Section IV.

### III Critical Technologies

Before introduction of Prop-Fan propulsion systems into commercial service, several critical technology issues remain to be resolved. This section discusses these key technology issues and the programs established to resolve these issues. SR Prop-Fan technology programs have been underway since 1975. CR Prop-Fan technology work has been started recently.

#### Aerodynamics

Small scale rotor models have been successful in defining uninstalled SR Prop-Fan aerodynamic performance levels and in developing design techniques. Rotor efficiencies above 80% have been demonstrated at cruise Mn levels from 0.7 to 0.8. Similarly, small scale aircraft models are being used to determine the installed performance of SR Prop-Fans. Results have been encouraging, especially for wings tailored for the swirl flow. Scale model propeller testing of this type is widely accepted by the aircraft industry. Large scale performance tests are less compatible with available wind tunnel facilities and are less accurate and repeatable in flight. As a result of these tests, SR aerodynamics performance potential is well understood.

CR Prop-Fans are predicted to achieve a higher uninstalled efficiency, and CR model testing will start in mid 1984. The same type of uninstalled and installed model test programs will have to be completed before industry can properly assess the efficiency potential of CR Prop-Fans.

It is also necessary to completely understand the swirl recovery aspects of a wing tailored to SR, since this may reduce the anticipated benefits of CR for a wing installation.

#### Acoustics

By 1987, source noise characteristics of a wing mounted SR Prop-Fan will have been thoroughly evaluated in model programs and LPA/PTA flight tests. Fuselage noise levels are expected to be higher in sound pressure levels (SPL) and different in spectrum from typical turbofan powered aircraft. Fuselage attenuation and structural isolation studies and tests are underway to achieve equal cabin comfort for a wing-mounted SR Prop-Fan to that of today's turbofan engines.

CR model programs are planned to determine source noise characteristics for both uninstalled and installed configurations. However, since acoustically lined wind tunnel limitations prevent acquisition of CR noise levels at high cruise Mach number, flight testing may be necessary. For pusher rear fuselage installations, a procedure must be found to investigate the unique acoustic effects of the pylon and engine exhaust

on the CR Prop-Fan. The ability to achieve acceptable structural isolation and cabin comfort for a rear fuselage installation is unknown and may also require flight testing to resolve.

Hamilton Standard has completed acoustic testing on the Fairey Gannet aircraft which has a CR propeller propulsion system. Hamilton purchased this post-World War II aircraft for early CR test data acquisition. Testing in 1982 and 1983 has yielded the first CR acoustic data. This aircraft is shown in flight in Figure 6 with its acoustic boom installed just under the port side, inboard wing fold.

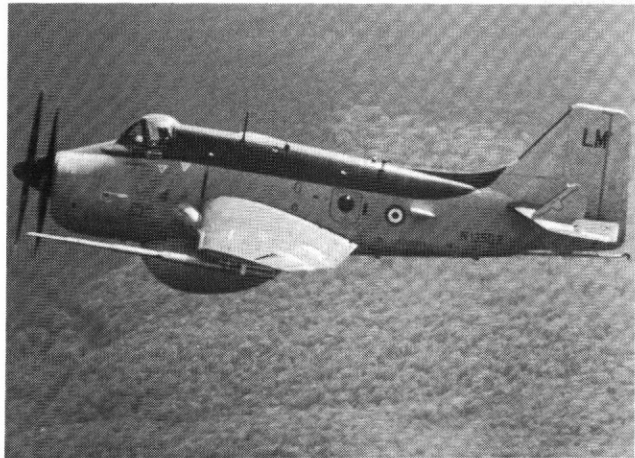

Figure 6. Fairey Gannet Aircraft with CR Propeller Blades

#### Rotor Blade Structure

The most critical rotor technology which remains to be verified is the structural integrity of the thin swept blade. Good performance is achieved by sweep and a low thickness ratio for all the SR and CR configurations intended to operate at or above 0.7 Mn cruise. The higher the cruise Mn condition, the greater the benefits of thin, swept blades. The importance of blade thinness and sweep is greater for CR than SR because each of the rotors in a CR system is operating at higher than free stream conditions. This is due to the induction effect on the front rotor and the slipstream effect on the rear rotor. The NASA LAP and PTA programs, in conjunction with SR and CR model tests, will provide the confidence in this blade structure for all tractor installations.

Pusher configurations, however, raise additional blade issues. These include the effect of the engine exhaust flow and pylon wake on the blade aerodynamics, acoustics, and structure. Wind tunnel testing has been conducted at Boeing on a SR Prop-Fan blade behind a simulated strut. Prop-Fan structural and acoustic data have been obtained with and without the strut and with various strut angles of attack. The engine exhaust temperature effect on pusher rotor blade structure means that blade materials normally used for tractors will be inadequate in this



environment. Pushers may therefore require unique blade materials and fabrication processes. Many exhaust concepts are under consideration to reduce the effect of the exhaust temperature on the Prop-Fan blades. Model tests are planned for the most promising of these concepts. It is expected that full scale blade component tests will be necessary for the pusher configuration.

### Gearbox

Another key technology issue is the large size (10000 to 12000 SHP) gearbox required for future 100 to 120 passenger twin engine aircraft. This reduction gearbox must have greatly improved durability and lower maintenance costs compared to past large size turboprop and reciprocating engine gearboxes. It is the goal of the gearbox designer to provide gearbox durability equal to that of the engine's cold section.

NASA and industry gearbox studies (Ref. 5 and 7) have identified modern technology in gear and bearing materials, gear tooth shapes, and a new unique lubrication system to achieve the durability goals. Figure 7 shows the gearbox concepts used in these studies -- a split path inline gearbox and a compound idler offset gearbox are best suited for the SR propulsion system, while a differential planetary inline gearbox is best for the CR propulsion system. A NASA-sponsored preliminary design activity for both SR and CR gearboxes is underway. Work to date indicates that a high technology and compact gearbox can be produced with the desired durability with an efficiency greater than present day gearboxes.

A NASA/Pratt & Whitney gearbox technology program is about to start. Demonstration of the performance of advanced technologies in a modern CR gearbox in the large size is scheduled for 1985 and 1986.

### Control System

The control system for the Prop-Fan propulsion system will utilize a dual channel full authority digital electronic control to regulate the Prop-Fan and engine. The major component in the system is an electronic unit which contains circuitry for digital computation, input and output conditioning and electrical power regulation. This portion of the control system is consistent with state-of-the-art full authority digital electronic engine control (EEC) technology for turbofan engines.

### Pitch Control

Pitch change systems for inline gearboxes have traditionally had components located either in the gearbox or engine with obvious limited access. Recent Hamilton Standard pitch change studies have produced designs which eliminate this problem. The pitch change system can now be packaged with the Prop-Fan rotor system and divorced from the gearbox. These concepts involve the generation of power in the spinning hub of the propeller. The only stationary-to-rotating interface involves the EEC signal transfer where several concepts are currently being explored. The interface with the gearbox is now very clean and the maintenance cost has been

## SINGLE ROTATION

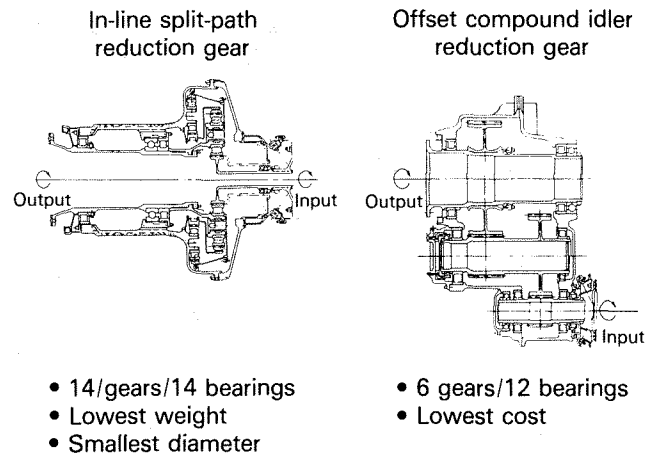

## COUNTER ROTATION

### Differential planetary

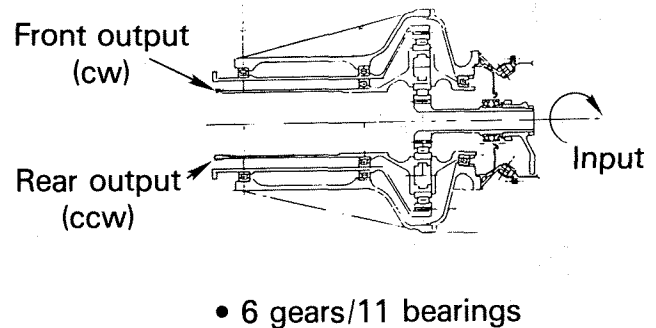

Figure 7. Best Gearbox Concepts From NASA/Pratt & Whitney Studies

reduced. However, this type of system does have some technology issues which will require component hardware programs for verification. These issues involve (1) the reliability of the digital signal transfer and its susceptibility to electro-magnetic interference or lightning and (2) the ability of electronic components to operate reliably with long life in a rotating environment. Component programs for these technologies have been initiated by Hamilton Standard.

### Turboprop Engine

A new advanced technology turboprop engine is required to realize the full potential of future Prop-Fan systems. No modern technology engine is available for use in the 10000 to 12000 SHP size required for future 100 to 120 passenger short range commercial transports. Engine selection studies (Ref. 4) have identified two optimum engine concepts with an overall pressure ratio around 38:1 and combustion exit temperature around 2600°F. One of these concepts, a two spool engine with an all axial compression system, has the best mission fuel burn. The other concept, a

three spool engine with an axi-centrifugal compression system, has the best direct operating cost. In either case, the engine manufacturer will be required to develop a new turboprop engine with advanced aerodynamics, high speed rotor systems, and advanced materials for future Prop-Fan applications.

For those companies who prefer the gearless direct drive approach, static ground testing of a demonstrator is scheduled for 1985 - 1986. This concept has a multi-stage statorless CR power turbine with two of its turbine stages directly connected at their outer diameter to CR Prop-Fans. It would appear that much development testing will be necessary to satisfy the aerodynamic, thermodynamic, and structural-mechanical concerns before this concept could be considered for commercial service.

### Inlet and Exhaust

For a tractor application, the engine designer is concerned with the interactive effects of the Prop-Fan exhaust flow with the inlet and nacelle. Shared model testing between various segments of the aircraft and engine industry and NASA has transpired in recent years. Results from these tests have been very encouraging. Continued testing in 1984 and beyond is projected to yield the necessary reference data for use in all future designs.

For geared pusher applications, the engine designer is concerned with the interactive effects of the core engine exhaust flow and the Prop-Fan. Model testing is planned to investigate and optimize the exhaust arrangement.

## IV Propulsion System Evaluation

SR and CR Prop-Fan propulsion systems in tractor configurations were compared to a high bypass ratio turbofan engine. All three propulsion systems used 1988 technology, i.e. 1992 propulsion system certification. The comparison was made in wing-mounted installations for a typical short to medium range commercial transport. Both Prop-Fan configurations were mounted over the wing to reduce aircraft landing gear length. Finally geared and gearless propulsion systems were evaluated in an aft mounted pusher configuration.

### Aircraft

A 120 passenger twin engine commercial transport, designed for a 1800 nautical mile (N.M.) range and with a 0.75 Mach number/35000 ft cruise condition, was selected as the typical Prop-Fan aircraft application. Both fuel burn and direct operating cost comparisons were made for all three propulsion systems. The comparisons were made for the design mission and also for a typical mission of 400 N.M. with a load factor of 60 percent.

### Prop-Fan Trades

A key to efficient engine operation is good propulsive efficiency. However, at high subsonic cruise speeds, peak propulsive efficiency doesn't necessarily translate into minimum fuel burn or direct operating costs. Figure 8 shows predicted SR and CR Prop-Fan efficiencies as power loading is varied. For both SR and CR, higher power loading (smaller diameter) means more blades to keep the efficiency from plummeting. CR efficiencies are significantly higher than for SR and excellent performance can be achieved with smaller diameter CR systems.

**CRUISE EFFICIENCY TRENDS**  
0.72 MACH, 35,000 FEET, 800 FPS TIP SPEED

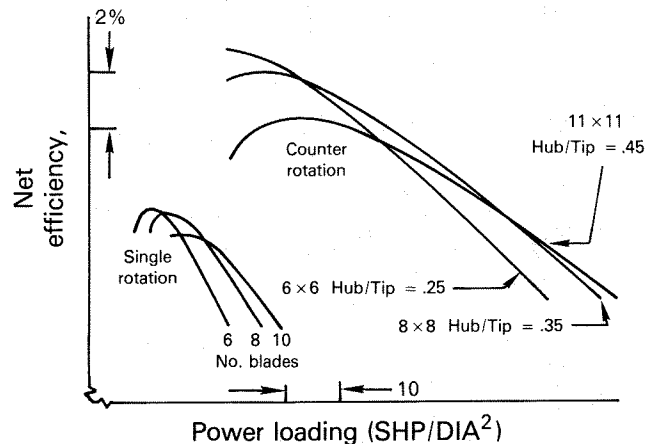

Figure 8. Single Rotation and Counter Rotation Prop-Fan Efficiencies

SR and CR optimization studies were conducted to select Prop-Fan parameters for minimum fuel burn (Ref. 4 and 5). Consideration was given to propulsion system TSFC, total propulsion system weight (including props, gearbox, and engine), Prop-Fan diameter and its effect on landing gear length, weight added to the fuselage for sound suppression, and the effect of propulsion system TSFC and weight on the aircraft takeoff gross weight (TOGW). The optimum SR Prop-Fan configuration has ten blades with a maximum climb loading of 36 SHP/D<sup>2</sup> and a tip speed of 800 ft/sec. The optimum CR Prop-Fan configuration has twelve blades (6 X 6) with a maximum climb loading of 42 SHP/D<sup>2</sup> and a tip speed of 750 ft/sec. The Prop-Fan designer usually selects max climb loading to the right of the peak efficiency (Figure 8) so that as power is reduced during cruise and other part power operation, efficiency will increase to minimize mission fuel burn.

Based on the experience with SR acoustic test level on scale models in wind tunnels, and on the Jetstar flight tests, it is expected that both the SR and CR systems selected for this study will meet FAR-36 acoustic requirements.

## Engines

The engines chosen for the study were the Pratt & Whitney STF-686 advanced high bypass ratio turbofan and the STS-678 advanced turboprop. These study engines reflect Pratt & Whitney's projections for 1988 technology availability. Table I compares the cycle characteristics for these engines in the final sizes required for the 120 passenger aircraft at its 1800 N.M. design range.

The critical engine sizing requirements are either takeoff field length equal to or less than 7000 feet at sea level 84°F, or initial cruise altitude capability equal to or greater than 35000 feet in the design mission. The choice of engine sizing requirements has an important effect on the comparison of a turbofan and Prop-Fan due to their differing thrust lapse rates with Mach number. The turbofan propulsion system was sized at the 7000 foot takeoff field length requirement and as such has excess cruise thrust capability at 35000 feet. On the other hand the Prop-Fan is sized at the top of climb-to-cruise altitude and has excess takeoff thrust. Selection of shorter field lengths or lower cruise altitudes would have favored the Prop-Fan and conversely, higher altitude cruise would favor the turbofan.

### Engine Aircraft Integration

Many areas of propulsion system/airframe interaction were considered in comparing Prop-Fan and turbofan powered aircraft. Two of the most important considerations were interference drag and cabin noise.

Installation of a Prop-Fan on a wing presents challenges quite different from those of a conventional turbofan installation. For this study we have selected an over-wing installation for landing gear length considerations. The major challenge is tailoring the wing to minimize the effects of the velocity and swirl in the Prop-Fan slipstream.

There has been no definitive answer as yet on the effect of these slipstreams on wings designed for Prop-Fans. For purposes of this study, we have assumed the increased velocity of the slipstream will affect friction drag of that portion of the wing scrubbed by it. No other interference drag penalties were assumed for the Prop-Fans, and no interference drag was assumed for the turbofan.

To account for the increased near field sound levels at cruise, the SR Prop-Fan aircraft has been penalized 1.8 percent takeoff gross weight (TOGW) compared to the turbofan aircraft and the CR Prop-Fan aircraft has been penalized 2.0 percent TOGW. These levels are consistent with those presented in references 8 and 9.

### Fuel Consumption

Figure 9 compares the cruise and part power fuel consumption of the three propulsion systems. This comparison includes real inlets and nozzles and horsepower extraction for airplane services. As shown in this figure, Prop-Fan engines have a significant fuel consumption advantage at cruise and a much greater advantage at lower Mach numbers. This is particularly important in shorter missions, like the typical mission where a greater percentage of the flight is at lower Mach numbers. The potential advantage of the CR Prop-Fan over the SR Prop-Fan reflects the improved efficiency inherent in CR.

### Engine and Aircraft Weights

A comparison of the propulsion system weights along with the operating empty weights and takeoff gross weights of the three aircraft is presented in Table II.

The SR Prop-Fan propulsion system is heavier than the turbofan; however, the CR system is lighter than either of the others. This is because the CR system's better TSFC results in a smaller size engine required to fly the design mission. The CR gearbox is also lighter than the SR gearbox.

The aircraft operating empty weight advantage of the turbofan over the SR Prop-Fan system reflects its propulsion system weight advantage plus the Prop-Fan's fuselage acoustic weight penalty. The operating empty weight of the CR aircraft is only slightly more than that of the turbofan because the CR's weight advantage tends to cancel its cabin acoustic weight penalty.

The significantly better TSFC of both Prop-Fans results in lower on-board fuel requirements, which gives both the SR and CR Prop-Fan powered aircraft lower takeoff gross weights than the turbofan powered aircraft.

TABLE I

ENGINE COMPARISON

	<u>Turbofan</u>	<u>Single Rotation Turboprop</u>	<u>Counter Rotation Turboprop</u>
Engine Takeoff Thrust - Sea Level 84°F	16600 lb	11560 HP	10060 HP
Bypass Ratio	7	90	80
Maximum Combustor Exit Temp. (°F)	2660	2600	2600
Turbofan/Prop-Fan Diameter (ft)	4.5	13.1	11.4

35,000 ft, M = 0.75

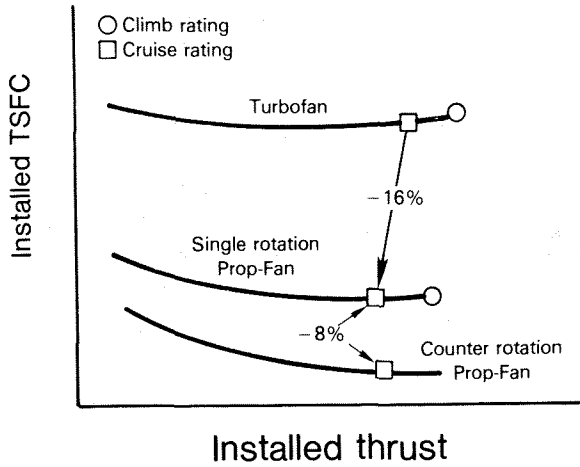

Installed thrust

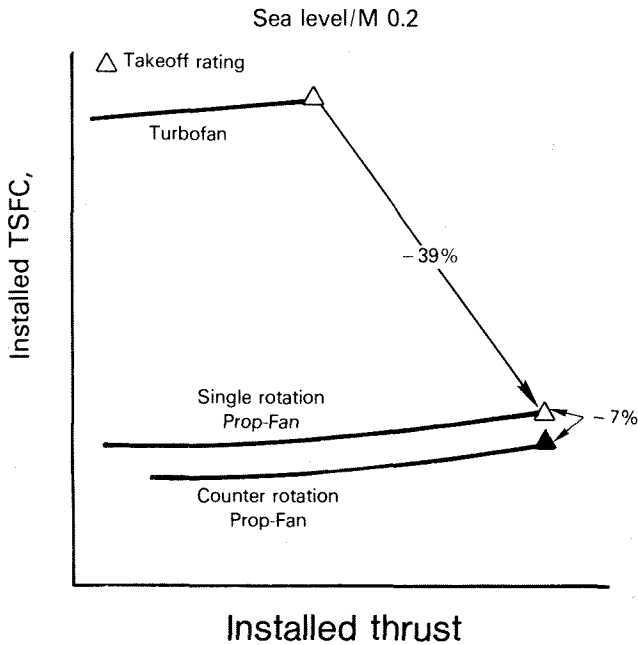

Installed thrust

Figure 9. Turbofan/Prop-Fan TSFC Comparison

Fuel Burn Results

A fuel burn breakdown for various segments of the typical mission is summarized in Table III. Airplanes were allowed to cruise at optimum altitudes, subject to 4000 ft steps. The turbofan aircraft values reflect a 39000 ft cruise altitude which had lower fuel burn than the 35000 ft minimum. Table III shows a 21 percent fuel burn savings for the SR Prop-Fan and a 31 percent fuel burn savings for the CR Prop-Fan compared to the similar technology high bypass ratio turbofan powered aircraft for the 400 N.M. typical mission.

Direct Operating Cost (DOC)

The DOC comparison for airplanes powered by the three systems flying the 400 NM typical mission are shown in Figure 10. Fuel burn is the major contributor to the Prop-Fan's DOC advantage. Differences in the other elements of DOC are small. The overall DOC advantages of the SR and CR Prop-Fans over the turbofan are 10 and 14 percent, respectively, based on a fuel price assumption of \$1.50 per gallon for 1995 fuel in 1981 dollars. If this value were reduced to \$1.00 per gallon the DOC advantage of the SR and CR Prop-Fans over the turbofan would be 8 and 12 percent, respectively.

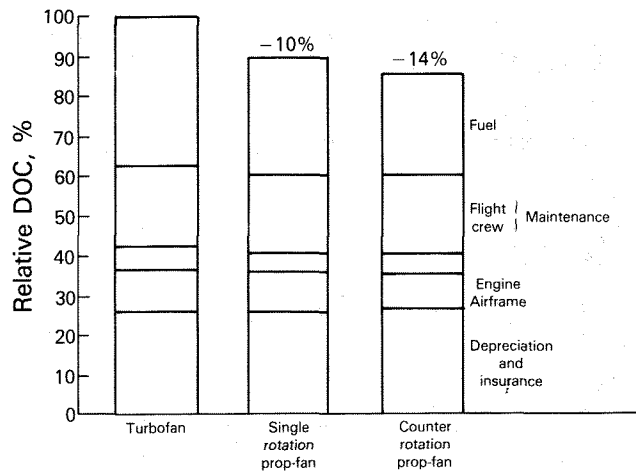

Figure 10. Relative DOC For 400 N.M. Mission

TABLE II

WEIGHT COMPARISON

	<u>Turbofan</u>	<u>Single Rotation Turboprop</u>	<u>Counter Rotation Turboprop</u>
Engine Size	16,600 Fn	11,560 SHP	10,060 SHP
Propulsion System Weight (lb)	Base	+9%	-7%
Aircraft Operating Empty Weight (lb)	Base	+4%	+0.5%
Aircraft Takeoff Gross Weight (lb)	Base	-0.5%	-5%



TABLE III  
400 N.M. MISSION FUEL BURN BREAKDOWN

	Turbofan			Single Rotation Prop-Fan			Counter Rotation Prop-Fan		
	Time (Min.)	Distance (N.M.)	Fuel* (lb)	Time (Min.)	Distance (N.M.)	Fuel* (lb)	Time (Min.)	Distance (N.M.)	Fuel* (lb)
Taxi	9.0	0	125	9.0	0	84	9.0	0	73.0
Takeoff	1.6	3.3	261	1.4	3.0	161	1.3	3.0	145.0
Climb	23.3	149.0	2121	17.7	111.4	1393.0	17.7	111.5	1223.0
Cruise	17.3	124.2	854	26.1	188.2	1118.0	26.1	188.3	988.0
Descent	20.6	123.5	296	16.8	97.4	147.0	16.8	97.1	122.0
Approach	4.1	0	154	4.1	0	100.0	4.1	0	87.0
Mission	5.0	0	69	5.0	0	47.0	5.0	0	41.0
<b>Total</b>	<b>80.9</b>	<b>400.0</b>	<b>100%</b>	<b>80.1</b>	<b>400.0</b>	<b>79%</b>	<b>80.1</b>	<b>400.0</b>	<b>69%</b>
Fuel Burn Comparison			BASE			21% Improvement			31% Improvement

\* Percent of Turbofan Total Mission Fuel Burned

Gear vs. Gearless Comparison

The previously described aircraft results were based on geared Prop-Fan propulsion systems. Recently, some segments of the Industry have proposed a gearless CR propulsion system with direct drive to the Prop-Fans.

A fuel burn and direct operating cost comparison was made of a gearless system with the geared CR system previously discussed. Both systems were compared in a pusher application using the two spool, all axial compression engine discussed in Section III. The geared system has a three-stage power turbine, a reduction gear, and a CR Prop-Fan behind the two spool gas turbine. The gearless system has a statorless 14 stage CR power turbine with the CR Prop-Fan blades being outboard and directly connected to two of the turbine stages (Figure 5).

Use of a gearbox permits optimization of the two major components -- the power turbine and Prop-Fan. Incorporation of a gearbox permits the design of a high speed, minimum number of stages, small diameter power turbine for maximum efficiency. At the same time, the gearbox permits the design of a low speed, lightly loaded Prop-Fan to once again optimize efficiency.

Eliminating the gearbox with a direct drive concept compromises both components with a low speed turbine and a higher speed, higher loading Prop-Fan. As discussed in Section III, the higher loading requires more blades to retain good efficiency. System speed will be set by the Prop-Fan tip speed at 800 ft/sec for acoustic reasons. The resultant low speed turbine requires many additional turbine stages and elimination of turbine stators to recover turbine efficiency. Figure 11 compares the turbine and Prop-Fan efficiencies of the two systems.

USE OF A REDUCTION GEARBOX PRODUCES HIGHER COMPONENT EFFICIENCIES

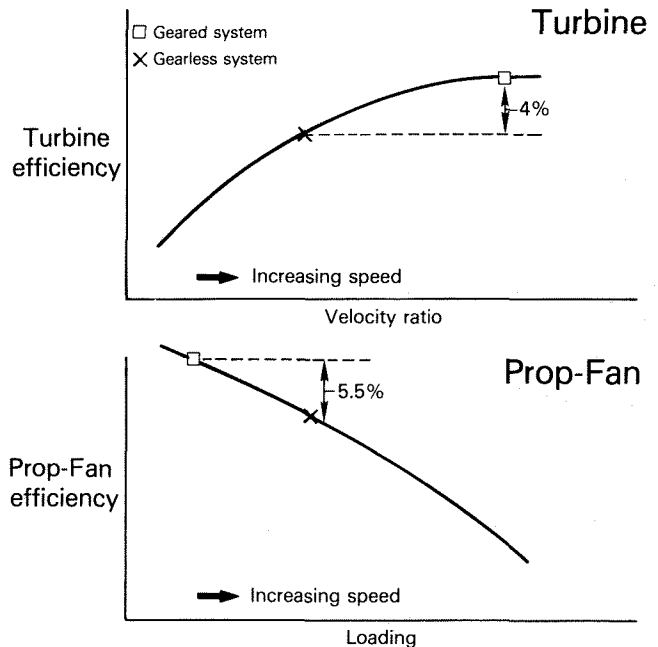

Figure 11. Comparison of Turbine and Prop-Fan Efficiencies for the Geared and Gearless Counter Rotation Prop-Fan Systems

The differences in component efficiencies plus the effects of the gearbox and oil cooler result in an overall 8.5 percent cruise TSFC advantage for the geared system over the gearless system.

Continuing the comparison, the poorer performance of the gearless system requires it to have a significantly larger engine (+9 percent in HP) to perform the design mission. The larger size engine plus the increased turbine and Prop-Fan blade count result in a 6 percent heavier propulsion system. The combination of an 8.5 percent performance advantage and 6 percent weight advantage of the geared system gives it an overall 10 percent fuel burned advantage over the statorless turbine direct drive system.

In the optimization process of both systems, the direct drive system has two advantages: the system is 19 inches shorter in length and has a 2 foot smaller diameter Prop-Fan. The geared system could in fact be designed for the smaller Prop-Fan diameter; however, it would lose about 5 percent of its 10 percent fuel burn advantage due to the resulting higher loading, lower efficiency Prop-Fan.

The geared system has a 6 percent direct operating cost advantage over the gearless system that is due mainly to the effects of the 10 percent fuel burned advantage and its high leverage on DOC. The gearless system has almost three times as many power turbine airfoils and almost twice as many Prop-Fan blades which more than balance the acquisition cost and maintenance cost of the reduction gear to make up the rest of the DOC difference. Table IV summarizes these results.

TABLE IV  
GEARED VS GEARLESS COUNTER ROTATION SYSTEM  
COMPARISON

	<u>Geared Engine Advantages Over Gearless</u>
Cruise TSFC	-8.5 percent
Engine Size (SHP)	-9 percent
Engine Weight (lb)	-6 percent
Fuel Burned	-10 percent
Number of Turbine Airfoils	one third
Number of Prop-Fan Blades	one half
Direct Operating Cost	-6 percent

In summary, the unique gearless system has distinct propeller diameter and system length advantages, but at the expense of inherent performance and economic disadvantages compared to a geared system. It would also appear that development and in-service problems in the as yet untested gearless concept with its unique multi-stage statorless turbine directly coupled to Prop-Fan blades could be more severe than the application of modern technology to a large gearbox.

#### V Concluding Remarks

The potential advantages of SR and CR Prop-Fans over comparable technology turbofans, 20 to 30% in fuel burn and 10 to 14% in direct operating cost, are significant. Both NASA and the United States aircraft and engine industries

are actively pursuing the necessary technologies for Prop-Fan powered aircraft in the early to mid 1990s.

Technology readiness for SR Prop-Fans is well along and by the time of the NASA-Lockheed flight test in 1987, most if not all of the SR technology issues will have been settled.

CR Prop-Fan technology readiness is lagging behind SR with model testing to start in 1984. CR aft mounted propulsion systems have many open issues such as the interactive effect of the blades, the effect of exhaust and pylon flow into CR pushers, and the unique but complex gearless pusher design. CR tractors appear more straight forward than pushers. It would appear that the next 2 to 3 years of model testing will be very crucial to future CR propulsion systems.

It would also appear that with the many choices available to future designers (SR or CR, tractor or pusher, wing or fuselage mount, and gear or gearless), that engine/aircraft integration is the key to achieving full Prop-Fan potential.

#### REFERENCES

1. Hamilton Standard, "Ten Blade Prop-Fan Data Package," HSD Report SP04A80, October, 1980.
2. Hamilton Standard, "Counter Rotation Prop-Fan Data Packs", February, 1983.
3. Gatzen, B. S., "Turboprop Design Now and the Future," International Council of Aeronautical Sciences, Seattle, Washington, August 1982.
4. Godston, J. and Reynolds, C. N., "Propulsion System Installation Configurations for Future Prop-Fan Powered Aircraft", 19th Joint Propulsion Conference June 1983.
5. Strack, W. C., Knip, G., Weisbrich, A. L., Godston J., Bradley E., "Technology & Benefits of Aircraft Counter Rotation Propellers," NASA TM-82983 Aerospace Congress & Exposition, Anaheim, CA, October, 1982.
6. Booth, M. A., "Advanced Turboprop Transport Development - A Perspective," International Council of Aeronautical Sciences, Seattle, Washington, August, 1982.
7. Godston, J. and Kish, J., "Selecting the Best Reduction Gear Concept for Prop-Fan Propulsion System," AIAA Paper 82-1124, Joint Propulsion Conference, Cleveland, OH, June, 1982.
8. Revell, J. D., Bolena, F. J. and Koval, L. R., "Analytical Study of Interior Noise Control by Fuselage Design Techniques on High Speed, Propeller Driven Aircraft," NASA CR-159222, April, 1980.
9. Revell, J. D., Bolena, F. J. and Koval, L. R., "Interior Noise Control by Fuselage Design for High Speed, Propeller Driven Aircraft," Journal of Aircraft, Volume 19, January, 1982, pp.39-45.