

A study on the dynamic performance of the 200km/h Korean tilting train by means of roller rig test[†]

Nam-Po Kim^{1,*} and Tae-Won Park²

¹Department of Vehicle Dynamics & Propulsion System, Korea Railroad Research Institute, Uiwang-City, 437-757, Korea

²Department of Mechanical Engineering, Ajou University, Suwon City, 443-749, Korea

(Manuscript Received December 24, 2008; Revised March 16, 2009; Accepted March 16, 2009)

Abstract

The dynamic performances of newly developed railway vehicles should be carefully verified step by step, from computer simulation through the laboratory-based roller rig test to the main line trial running test. The laboratory-based roller rig test is an effective and safe way to evaluate the dynamic characteristics such as high speed, ride comfort and dynamic behaviors. This experimental research was performed to evaluate the dynamic performances of the 200 km/h Korean tilting train, 'Hanvit200', by means of a full scale roller rig test. The newly developed tilting mechanism and stabilizer were included in the tilting bogie to satisfy both the conflicting requirements of higher stability and higher curving performance. This paper shows the roller rig test results and the effectiveness of tilting bogie design. Included are the roller rig test results of various kinds of conditions such as tare and fully laden load case, normal and failed case of important bogie components, linear and non-linear critical speed.

Keywords: Critical speed; Dynamic performance; Ride comfort; Roller rig; Tilting train

1. Introduction

The tilting train is able to increase the curving speed without reducing travel safety or passenger comfort. Therefore the application of a tilting train is one of the most effective ways to reduce the journey time on conventional line with many curves and also without enough budget to construct a high speed line[1-2]. Many countries have paid increasing attention to the development of the tilting train. Now the tilting train has been put into service in many countries around the world such as in Europe, America, China and Japan. In Korea, the tilting train has not yet operated, but the Korea Railroad Research Institute (KRRRI) has developed Korean tilting train 'Hanvit200' for the first time. The objective of this tilting

train is to increase the speed of the conventional lines such as Jung-ang lines where the high speed KTX service is not provided and there are many curved sections.

2. Korean tilting train

The Korean tilting train 'Hanvit200' was designed for maximum speed of 200 km/h. The train is equipped with an active vehicle body tilting system, which makes it possible to negotiate the curve track with 30% higher speed than a normal train without affecting passenger comfort. Hanvit200, electrically multiple unit type, consists of 6 cars as shown in Fig. 1. To increase the speed on the existing lines with minimum reinforcement of infrastructure, reduction of weight is important. Therefore a distributed propulsion system (4 motor cars and 2 trailer cars) was adopted and the FRP-based hybrid materials were applied to the vehicle body to achieve the maximum

[†] This paper was presented at the 4th Asian Conference on Multibody Dynamics (ACMD2008), Jeju, Korea, August 20-23, 2008.

* Corresponding author. Tel.: +82 31 460 5665, Fax.: +82 31 460 5299
E-mail address: npkim@krrri.re.kr

© KSME & Springer 2009



Fig. 1. Overview of Korean tilting train.

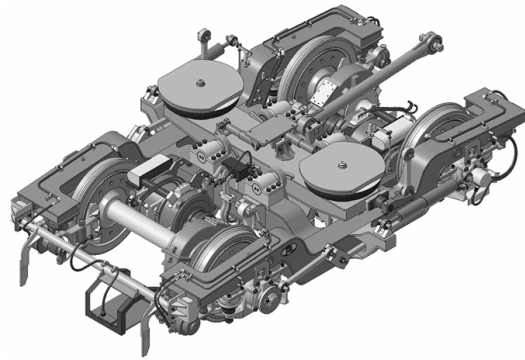

Fig. 2. Overview of tilting bogie.

axle load 15 tons .

In the bogie of the Korean tilting train, a tilting bolster and tilting mechanism are installed to support and tilt the vehicle body[3]. The four-bar linkage system was adopted for the bogie tilting mechanism as shown in Fig. 2. To achieve both the high speed stability and curving performance, which conflict with each other in a conventional bogie, the soft yaw stiffness and link type stabilizer were applied.

3. Roller rig test and evaluation

3.1 Roller rig test installation

The full-scale roller rig used for this study is shown on Fig. 3. The rollers of the roller rig which simulate the track can both rotate and vibrate in lateral and vertical directions. The rotation of the roller rig simulates the forward speed of the vehicle and the excitation of the roller rig simulates the track irregularities.

The one set of testing bogie for motorized car was assembled with the front side of a dummy car body which has same weight. The rear side of the dummy

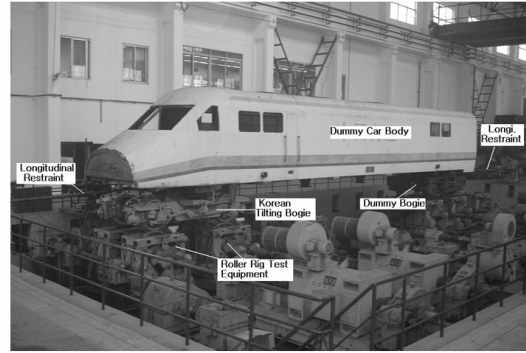

Fig. 3. Overview of Roller rig test.

car body was supported by a typical dummy bogie as shown in Fig. 3.

3.2 Test condition and scenario

Two kinds of weight conditions were considered: for tare load and for full load condition. At tare load condition 16.5 tons was applied above the test bogie, and 19.0 tons under full load condition. The track has random irregularities with 5 km length which were selected from a typical 200 km/h line

The scenario of the roller rig test was based on a combination of various kinds of cases below :

- to predict linear critical speed without external excitation
- to predict non-linear critical speed with external excitation
- to evaluate vibration ride comfort with external excitation to simulate typical track irregularity
- to evaluate the effect of yaw damper for stability, the test was conducted without/ half with/ fully with yaw damper
- to evaluate the effect of stabilizer for stability, the test was conducted with /without stabilizer
- to evaluate the ride comfort in case of air spring inflated(normal)/ deflated case

3.3 Test results of stability

The dynamic stability can be quantitatively expressed by critical speed. The linear critical speed is the speed at which the train becomes unstable and hunting motion is excited under the ideal track condition. Nonlinear critical speed is the speed at which the lateral vibration induced by initial external excitation does not diminish. Both critical speed tests was done under the tare load and full load condition. Also, the

Table 1. Critical speed at tare load.

Test case	Normal	Yaw damper failure	Stabilizer failure	Yaw & stabilizer failure
Linear Vcr [km/h]	Approx. 290	Stable up to 240	Stable up to 240	Stable up to 240
Non-linear Vcr	Stable up to 280	Stable up to 240	Stable up to 240	Stable up to 240

Table 2. Critical speed at full load.

Test case	Normal	Yaw damper failure	Stabilizer failure	Yaw & stabilizer failure
Linear Vcr [km/h]	Stable up to 240	Approx. 210	Approx. 230	Approx. 185
Non-linear Vcr	Approx. 240	Approx. 190	Approx. 220	Approx. 180

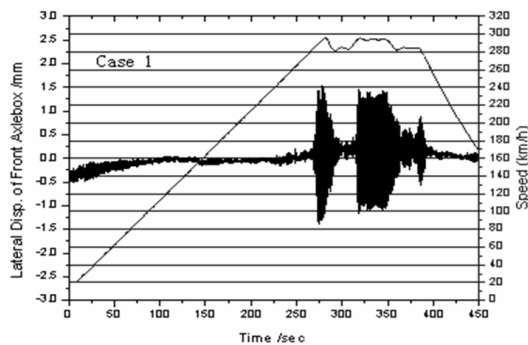

Fig. 4. Linear Vcr at tare load and normal condition.

critical speed was done under the normal and components failed condition. Tables 1 and 2 show the critical speed(Vcr) of each test case at tare load and full load, respectively.

The stability or critical speed can be estimated by rapid increase of lateral displacement of the axle box. Some test results are shown in Fig. 4 and Fig. 5. In the linear critical speed test, the speed at which the vehicle becomes unstable is slightly different from the speed at which the vehicle returns to stable state. For the full load and yaw damper failed case, beginning critical speed is approximately 220 km/h and returning critical speed is approximately 200 km/h

3.4 Test results of ride comfort

The ride comfort tests was conducted from 60 km/h to 200 km/h with the external excitation correspond-

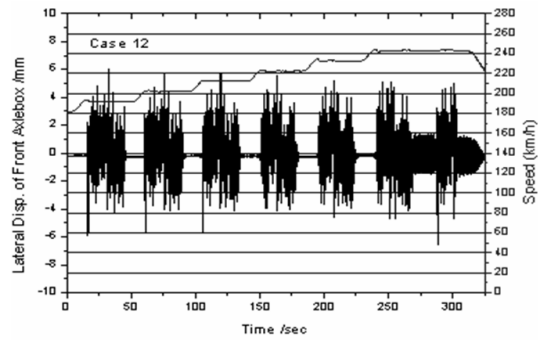

Fig. 5. Non-linear Vcr at full load and normal condition.

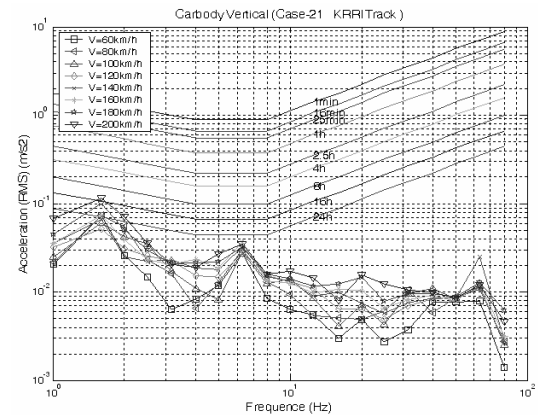

Fig. 6. Vertical reduced comfort level at tare load

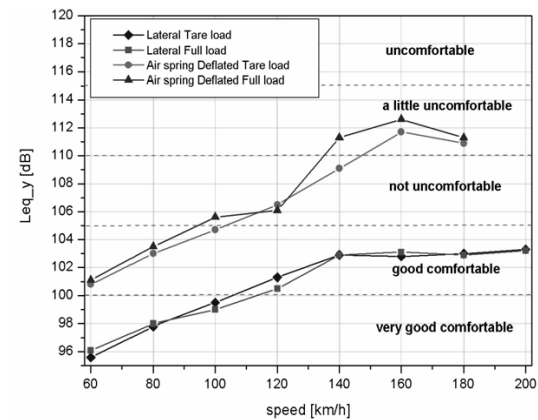

Fig. 7. Lateral ride comfort level Leq at various test case.

ing to typical track irregularities as shown in Fig. 4. According to ISO2631 and KS R9216, the reduced comfort boundary level and ride comfort level Leq are post processed. Fig. 6 shows the results of vertical reduced comfort level at tare load and air spring normal case. The dominant frequency in vertical direc-

tion is 1.7 Hz, which corresponds to the pitching mode of the vehicle body.

Fig. 7 shows the results of ride comfort level Leq versus the speed. Both Leq s at tare and full load case are not different. The lateral comfort level at normal condition was 'good comfortable' up to 200 km/h, and also the vertical comfort level was 'not uncomfortable' up to 200 km/h

4. Conclusions

Through the roller rig dynamic test of the tilting bogie for Korean tilting train, the following conclusions can be made:

The tilting bogie at both tare and full load conditions has sufficient hunting stability. All the critical speeds even the failure mode case were above the maximum operating speed of 180 km/h.

The critical speeds at tare load condition are higher than the values at full load condition. The critical speed was very sensitive to yaw damper and a little sensitive to the stabilizer .

Due to the difference between the roller with finite radius and real rail with infinite radius, the critical speed estimated by roller rig test may be different from a real one.

The bogie suspension had the proper performance of vibration isolation. The ride comfort levels met the requirement for bogie design up the target operating speed of 180km/h. The ride comfort became much worse in case of deflated air spring.

Due to the difference between test bogie installation with dummy body and real vehicle body, the results of vibration did not reflect the yaw and pitch motion of the vehicle body and also the flexible mode of a real body.

Acknowledgment

This work was a parts of the Research Program supported by the Ministry of Construction and Transportation (Development of Railway Technologies), Korea.

References

- [1] International Union of Railways, *First Report on Tilting Train Technology-The state of the art*, UIC High speed division Paris. (1998).
- [2] J. Forstberg, *Ride comfort and motion sickness in tilting train*, Doctoral thesis, Department of vehicle engineering Royal Institute of Technology , (2000).
- [3] N. P. Kim, J. S. Kim, S. I. Seo and T. W. Park, *Experimental study on the fatigue strength of the bogie frame for tilting railway vehicles*, Key Engineering Materials, Vols. 321-323 (2006).



Nam-Po Kim received a B.S. degree in Mechanical Engineering from Ajou University in 1985. He then went on to receive his M.S. and Ph.D. degrees from Ajou University in 1992 and 2008, respectively. Dr. Kim is currently a principal researcher at the department of vehicle dynamics and propulsion system at Korea Rail Road Research Institute in Uiwang, Korea. His research interests are in the area of railway vehicle dynamics, active control of running gear for railway vehicle and vehicle system engineering.