

Dec. 11, 1928.

1,694,981

C. P. RANDOLPH
ELECTRIC WAFFLE IRON

Filed Aug. 23, 1926

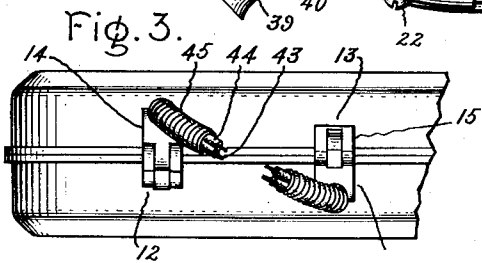
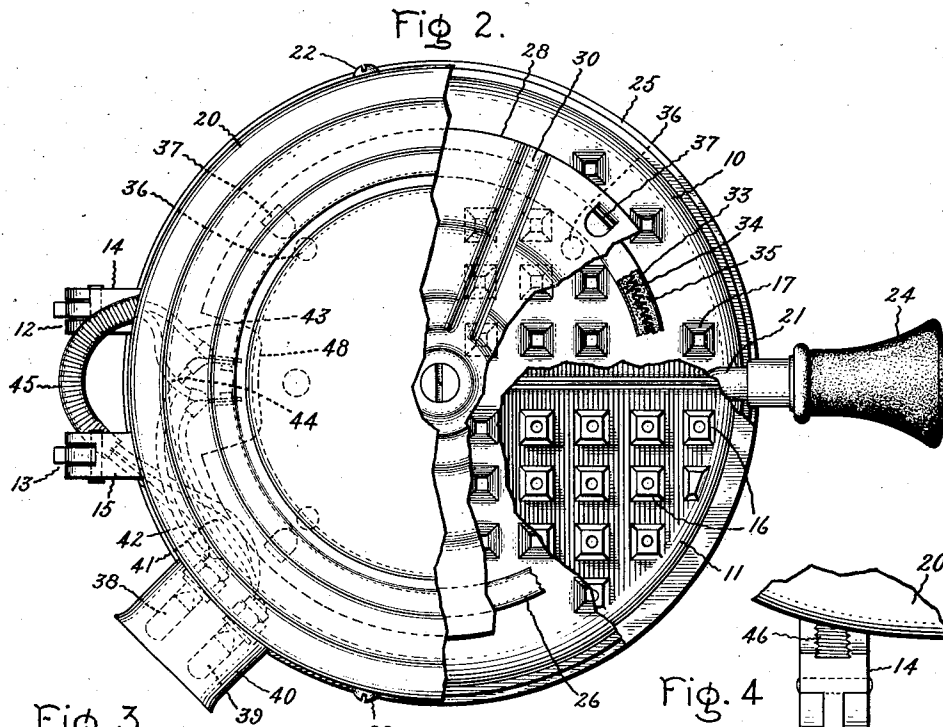
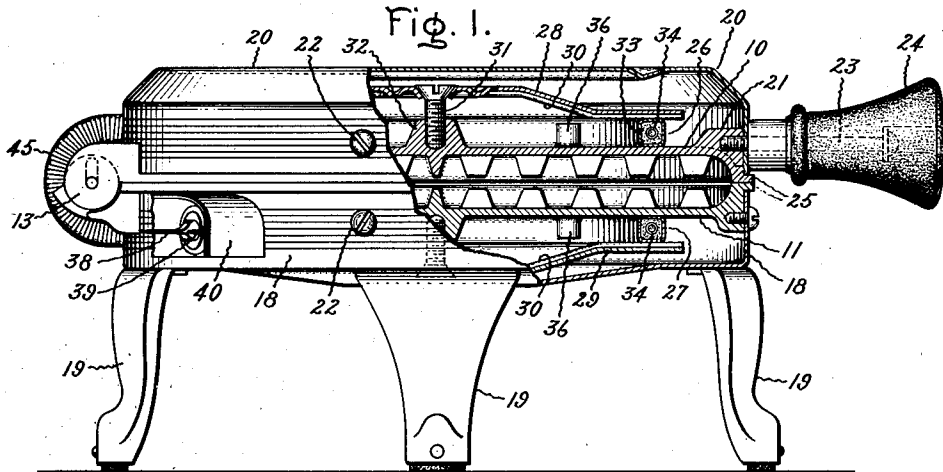
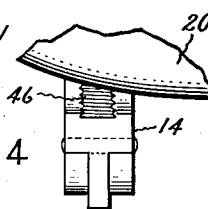

Fig. 4



Inventor:
Charles P. Randolph,
by *Myron S. Lane*
His Attorney.

UNITED STATES PATENT OFFICE.

CHARLES P. RANDOLPH, OF OAK PARK, ILLINOIS, ASSIGNOR TO EDISON ELECTRIC APPLIANCE COMPANY, INCORPORATED, OF CHICAGO, ILLINOIS, A CORPORATION OF NEW YORK.

ELECTRIC WAFFLE IRON.

Application filed August 23, 1926. Serial No. 130,810.

My invention relates to electric waffle irons and has for its object the provision of a simple, reliable and efficient device of this type.

For a more complete understanding of my invention reference should be had to the accompanying drawing, in which Fig. 1 is an elevation view partly in section of a waffle iron embodying my invention; Fig. 2 is a plan view also partly in section of the device shown in Fig. 1; while Figs. 3 and 4 are fragmentary views showing the details of construction.

Referring to the drawing, in carrying out my invention in one form I provide two waffle iron cooking plates or molds 10 and 11 which are pivotally connected together by means of two spaced hinges 12 and 13. These two plates are preferably cast from a suitable metal having good heat conductivity, such as aluminum. They are identical in construction, the lugs 14 and 15 on each plate, forming the hinged connections, are cast integral with the plates and are provided with one and two hinge members respectively so that when the plates are placed together face to face in inverted relation a single hinge member on one plate fits between the two spaced hinge members on the other plate thus forming the two hinges. Vertically elongated apertures for the pivot pins of the hinges are provided whereby the upper plate may be lifted in parallel relation with the lower by the cooking of the waffle. It will be understood that the adjacent surfaces of the two plates are provided with the usual waffle mold protuberances 16. These protuberances are preferably hollow, whereby depressions 17 are formed in the backs of the plates, as indicated in Fig. 2.

The lower plate 11 rests in a casing 18 which is provided with legs 19 forming supports for the waffle iron. A somewhat similar casing or cover 20 is provided for the upper plate 10. At intervals around the periphery of the plates are lugs 21 provided with tapped holes and the casings 18 and 20 are secured to the plates by screws 22 fitting in these tapped holes. As shown the casings are secured at three equally distant points around the periphery of the plates one of these points being directly opposite the hinges 12 and 13. At this latter point a much longer screw 23 is used for the upper plate 10, which screw extends through a handle 24 for the upper plate, thus securing both the han-

dle and casing to the plate at this point. Each of the plates is provided with a ledge 25 around its periphery on which the casing is seated. At the back the casings are cut away so as to fit closely around the projecting lugs of the hinges.

The two plates 10 and 11 are heated by means of electric heating units 26 and 27 respectively which are secured against the backs of the plates by means of clamping plates 28 and 29. The clamping plates are circular in outline and formed with equally spaced radially extending ribs 30. As shown eight of these radial ribs are provided in each plate. They are provided for the purpose of stiffening the plate and also to hold the main body of the plate in a spaced relation with the heating unit, the plate being placed on the unit with the ribs in engagement with it. This greatly limits the conduction of heat to the plate. Each clamping plate is secured to its corresponding waffle iron plate by means of a central screw 31 which engages with a tapped bore formed in a protuberance 32 cast in the center of the waffle iron plate. The clamping plate is struck upward at the center somewhat in order to clear the projection 32.

While any suitable electrical heating unit may be used which is adapted to be clamped against the back of the cooking plate, I have shown a heating unit of the sheathed type, such as described and claimed in Patent No. 1,367,341 to Abbott dated February 1, 1921. This unit briefly comprises an outer metallic sheath 33 in which a helically shaped resistance wire 34 is embedded in a powdered heating refractory electrically insulating material such as magnesium oxide. The powdered insulating material is compacted to form an efficient conductor of heat. The heating units 26 and 27 consist of lengths of this sheathed resistance wire which are bent in circular form and to such a diameter that the heating unit has the proper position with respect to the periphery of the waffle iron plate to give a substantially even distribution of heat throughout the cooking surface, due regard being given to the relatively free dissipation of heat from the periphery of the cooking plate. The generation of heat is thus concentrated in a relatively narrow zone around the plate. In order to properly position the heating unit a plurality of projections 36, as shown four, are cast on the back of

each plate in such positions that the heating unit fits loosely around them and is thereby positioned on the cooking plate. The heating unit is further positioned by means of spaced tabs 37 which are struck downward out of the clamping plate so as to loosely engage the outer periphery of the heating unit.

Electrical connections for the two heating units are brought in at the rear of the waffle iron adjacent the hinges, the heating units being placed on the cooking plates in such position that their ends from which terminals for the resistance wires project are at the rearward or hinge sides of the plates. Suitable electrical contact pins 38 and 39 are secured to the lower casing 18 adjacent the hinges, these pins being protected by a suitable guard 40. Insulated electrical conductors 41 and 42 are led from these pins, which are insulated with respect to the casing, to the lower heating unit 27. For the upper heating unit 26 insulated conductors 43 and 44 are led from the contact pins through the casing 18 adjacent the lower side of the hinge 13 thence through a flexible conduit 45 upward to the upper side of the hinge 13 where the conductors enter the casing 20 and pass to the terminals of the heating unit 26. The flexible conduit 45 allows the upper plate to be lifted and lowered freely on its pivot. The conduit 45 is shown as being of a construction often used with armored conductors. It resembles somewhat a helix of wire in construction and appearance, the helix preferably being made of a specially formed strip so arranged that the turns overlap and interlock internally.

As shown in Figs. 3 and 4, one of the hinge lugs on each waffle iron plate is provided with a semicircular recess or groove, forming a seat for one end of the flexible conduit 45. Since the two plates, which are identical in construction, are secured together in inverted relation, this brings one recess at each hinge. As shown, the lug on the upper plate forming a part of hinge 12 is provided with a recess 46 for the upper end of the conduit 45, while the lug on the lower waffle iron plate forming a part of hinge 13 is provided with a similar recess for the lower end of the conduit. These recesses are provided with grooves or threads in which fit the end turns of the conduit whereby the conduit is secured, the conduit being held in the grooves and further secured by the casings 18 and 20, which are provided with recesses fitting closely around the conduit. In order to provide space for the connections each clamping plate is cut away in the vicinity of the terminals of the heating unit as indicated by the reference numeral 48 (Fig. 2).

While I have described my invention as embodied in concrete form and as operating in a specific manner in accordance with the provisions of the patent statutes, it should be

understood that I do not limit my invention thereto since various modifications thereof will suggest themselves to those skilled in the art without departing from the spirit of my invention, the scope of which is set forth in the annexed claims.

What I claim as new and desire to secure by Letters Patent of the United States, is:—

1. An electric waffle iron comprising two metallic cooking plates, hinge lugs secured to said plates, a pivotal connection between said lugs, a sheathed electric heating unit on the back of each of said cooking plates, a plate provided with radial ribs for clamping said heating units on said cooking plates, covers secured to said cooking plates fitting over said heating units in spaced relation therewith, and supporting means secured to one of said covers

2. An electric waffle iron comprising two cooking members, each of said members comprising a cast metal waffle cooking plate, a sheathed electric heating unit on the back of said plate, a clamping plate for said heating unit provided with a central aperture and with a plurality of ribs for engagement with said heating unit, a screw passing through said aperture in screw threaded engagement with the center of said cooking plate whereby said heating unit is clamped against the back of said cooking plate, and a cover secured to said cooking plate fitting over said heating unit and clamping plate in spaced relation therewith.

3. An electric waffle iron comprising two cooking members, each of said members comprising a cast metal waffle cooking plate, a single circular length of a sheathed electric heating unit having substantially the same outline as said plate but of lesser diameter, a clamping plate for securing said heating unit on the back of said plate and projections on the back of said plate for positioning said heating unit.

4. An electric waffle iron comprising two cooking members, each of said members comprising a cast metal waffle cooking plate, a single circular length of a sheathed electric heating unit on the back of said plate, a clamping plate for said heating unit, said clamping plate being provided with a central aperture and with a plurality of radial ribs in engagement with said heating unit, a screw passing through said aperture in screw-threaded engagement with the center of said cooking plate whereby said heating unit is clamped on said cooking plate, projections on the back of said cooking plate and on said clamping plate for positioning said heating unit, a cover secured to said cooking plate fitting over said heating unit and clamping plate in spaced relation therewith.

5. An electric waffle iron comprising two cooking members, each of said members com-

prising a disk-shaped cast metal waffle cooking plate, a circular sheathed electric heating unit on the back of said plate, a circular clamping plate provided with a central aperture and with radial ribs engaging said heating unit at intervals, and a screw passing through said aperture in screw-threaded engagement with the center of said cooking plate whereby said heating unit is clamped against the back of said cooking plate.

6. An electric waffle iron comprising two pivotally connected cooking members, each of said members comprising a metal cooking plate having hinge lugs secured directly thereto, one lug on each plate being provided with a recess, a flexible conduit extending between said plates having its ends secured in said recesses so that said conduit flexes when said plates are moved relatively on their pivot, heating units for said plates, and elec-

trical connections passing through said conduit to the heating unit for one of said plates.

7. An electric waffle iron comprising two pivotally connected cooking members, each of said members comprising a metal cooking plate having hinge lugs secured directly thereto, one lug of each plate being provided with a grooved recess, a coiled flexible conduit extending between said plates having a plurality of coils at each end secured in said recesses so that said conduit flexes when the plates are moved relatively about their pivot, covers for said plates securing said conduits in said recesses, heating units for said plates, and electrical connections passing through said conduit to the heating unit for one of said plates.

In witness whereof, I have hereunto set my hand this 17th day of August, 1926.

CHARLES P. RANDOLPH.