



George F. Stecher
Vehicle Development Specialist
Advanced Engine
Systems Development



Chrysler Motors Corporation
CIMS: 418-32-12 P.O. Box 1118
Detroit, MI 48288
(313) 956-3711



History of
Chrysler Corporation
G A S T U R B I N E
V E H I C L E S



CHRYSLER
CORPORATION

**HISTORY OF CHRYSLER CORPORATION'S
GAS TURBINE VEHICLES**

**Prepared By
Technical Information
Engineering Office**

January 1979

CONTENTS

	Page No.
INTRODUCTION.	1
FUNDAMENTALS OF ENGINE OPERATION	2
THE FIRST TURBINE CAR	6
THE SECOND GENERATION TURBINE ENGINE	10
THE THIRD GENERATION TURBINE ENGINE	11
THE FOURTH GENERATION TURBINE ENGINE	19
THE FIFTH AND SIXTH GENERATION TURBINE ENGINE	29
THE SEVENTH GENERATION ENGINE	33
EMISSIONS AS A CRITICAL DESIGN PARAMETER	39
THE FUTURE	42

INTRODUCTION

The earliest work on gas turbine engines at Chrysler Corporation dates back to the late 1930s, before World War II, when an exploratory engineering survey was conducted. This survey indicated that the gas turbine engine had the potential to become an automotive power plant. It also indicated, however, that neither materials nor turbine design and manufacturing techniques had advanced to the point where the cost and time of intensive research would be warranted.

At the close of World War II, studies on new concepts in gas turbine design were started. As a result of this work, Chrysler was awarded a contract by the U. S. Navy in late 1945 to design and build an aircraft turboprop engine. This contract, although terminated in 1949, resulted in the development of a turboprop engine which achieved fuel economy approaching that of piston-type aircraft engines.

Chrysler research scientists and engineers then returned to their original objective -- the automotive gas turbine engine. During the early 1950's, experimental gas turbine power plants were operated on dynamometers and in test vehicles. Active component development programs were carried out to improve compressors, regenerators, turbine sections, burner controls, gears, and accessories. Progress was such that in early 1954, Chrysler announced the successful road testing of a production car powered by a turbine engine. Thus, the potential of the gas turbine was convincingly demonstrated and was shown to warrant further research and development.

Significant advances in fundamental gas turbine engine technology were made by Chrysler during the subsequent eighteen years. This expertise was recognized by the award of a Federal government contract in late 1972 to develop a gas turbine-powered car which met certain emission, fuel economy, performance, and cost requirements. Chrysler's 6th-generation turbine engine was selected as the baseline engine for upgrading to meet the contract goals. Work on this contract is expected to be completed in 1978.

In today's search for viable options in conserving our nation's energy, the gas turbine engine continues to be a prime candidate as an alternative power plant to the conventional automotive piston-type engine. Factors on which this conclusion is based include:

- Excellent fuel economy potential
- Inherent multi-fuel capability
- Inherent low exhaust emissions; no exhaust aftertreatment required
- Fewer moving parts
- Reduced maintenance
- Long engine life expectancy
- Engine coolant not required
- Vibration-free engine operation
- Engine does not stall with sudden overloading
- High standing start breakaway torque
- Reduced engine weight
- Negligible oil consumption
- No warm-up period necessary
- Cool exhaust gases
- Exhaust muffler/silencer not required.

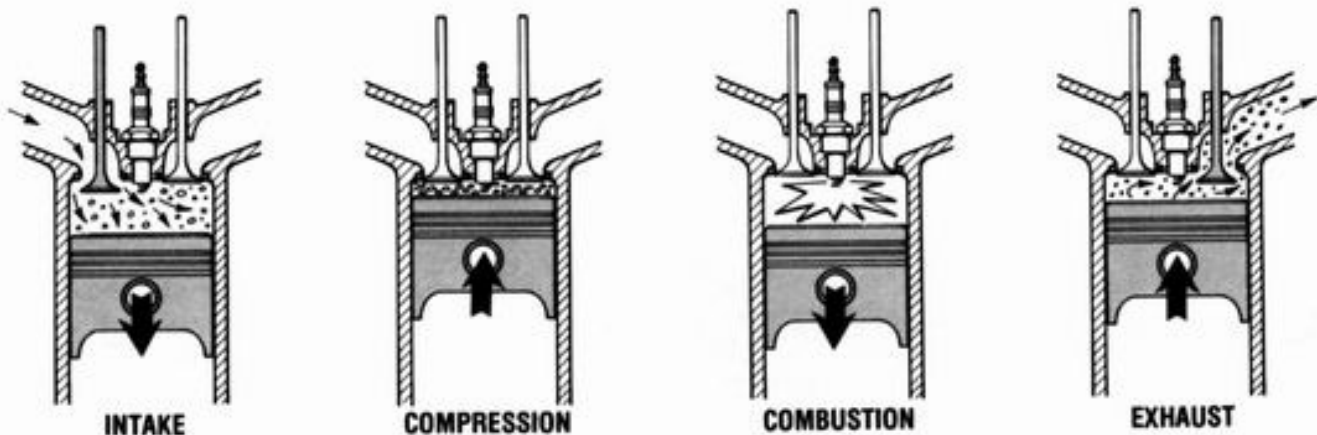

PISTON ENGINE OPERATION

FUNDAMENTALS OF ENGINE OPERATION

Both the gas turbine engine and the conventional piston-type, four-cycle engine operate through use of air induction, compression, heating, and expansion. These functions occur repeatedly in each cylinder of a piston-type engine, but in the gas turbine engine, they are a continuous process, occurring in stages throughout components of the engine. The principal difference in the thermodynamic cycles of the two engines is that in the piston engine, combustion occurs at a constant volume (all at once when the piston is near the top of the cylinder) whereas in the turbine engine, combustion is continuous at a constant pressure. The peak pressures in the gas turbine engine range from 5 to 45 psi (34 to 310 kPa), idle to maximum power, while those in the piston engine are about ten times greater but are of very short duration.

A gas turbine engine has several major components connected together to form an operating system. In a typical aircraft jet engine, which is a type of gas turbine engine, air is first drawn into a compressor which increases air pressure and temperature. This air is then forced into a burner where it mixes with fuel, and combustion occurs. After being heated by combustion, hot gases expand through one or more turbine wheels to transform the thermal energy in the hot, high-pressure gases into mechanical energy. In a jet engine, the turbine wheel(s) take out only enough energy to drive the engine's compressor and the airplane accessory systems. Most of the energy remains in the stream of exhaust gases, so propelling power is provided by the forward thrust produced by the exhaust gas as it leaves the engine's tailpipe.

An aircraft turboprop engine, although quite similar to the jet engine, is more like an automotive gas turbine. It has an additional turbine wheel, a power turbine wheel, which uses most of the energy in the exhaust gases and transforms it into driving power for the propeller. In an automobile gas turbine engine, the power turbine wheel is used to deliver power to the wheels of the car.

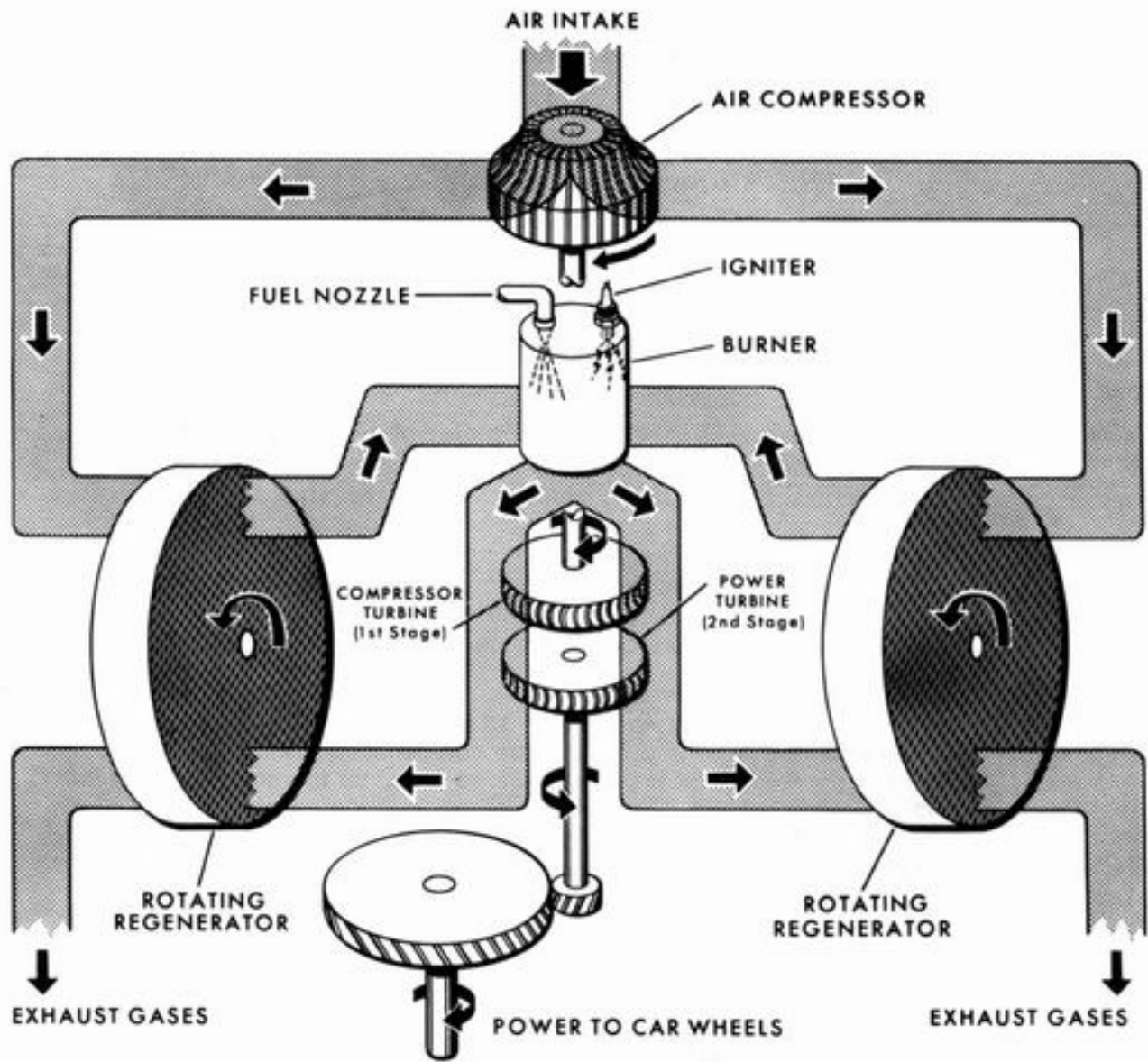
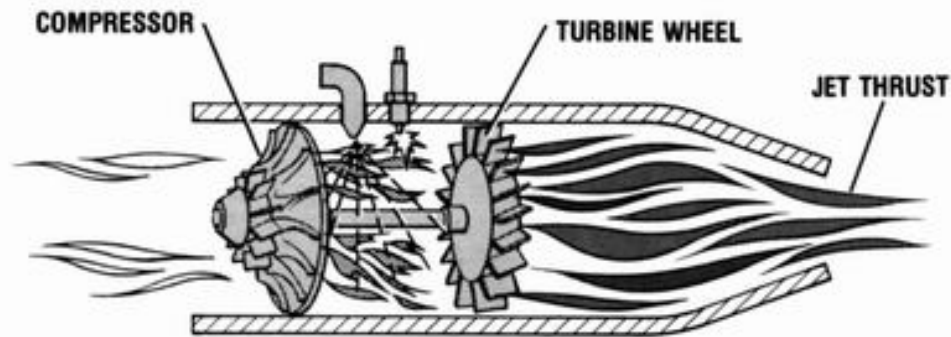

DIAGRAM OF GAS TURBINE OPERATION



AIRCRAFT JET ENGINE

The turbine engine "makes its own wind." In an aircraft jet engine, the compressor draws in cool air which combines with fuel to produce a hot, rapidly expanding gas -- the "wind." This gas turns the turbine wheel -- the "windmill" -- which turns the compressor. The hot exhaust gases, escaping from the rear, provide jet thrust.

To perform efficiently the functions of an automotive power plant, Chrysler's gas turbine is designed with these main units:

- Air compressor
- Burner
- First-stage turbine wheel (compressor turbine) to drive the compressor
- Second-stage turbine wheel (power turbine) to drive the car
- Regenerator(s).

The air compressor draws in air and compresses it to raise the pressure, at maximum power, to about 4 atmospheres, or about 45 psi (310 kPa). In the process of compression, air temperature rises several hundred degrees. This compressed air flows through the regenerator(s) where in current engines it picks up more heat, up to about 1400°F (760°C), and then enters the burner, where it combines with fuel, producing a temperature of about 1925°F (1052°C). This very hot stream of high-pressure gas then forces its way through the blades of the compressor turbine, which turns the compressor. It then goes through the blades of the power turbine, which is connected to the rear wheels to drive the car.

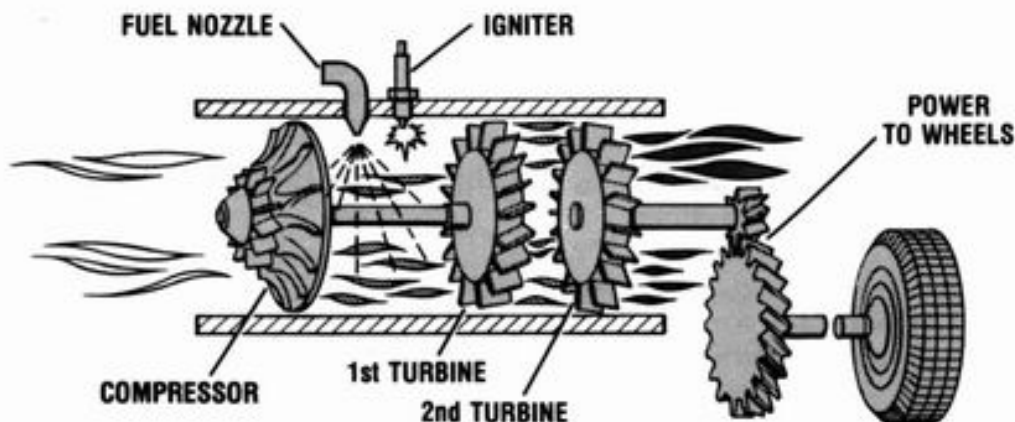

AUTOMOTIVE GAS TURBINE ENGINE

In the automotive gas turbine engine, there are two stages: 1st turbine drives the compressor; 2nd turbine drives the wheels.

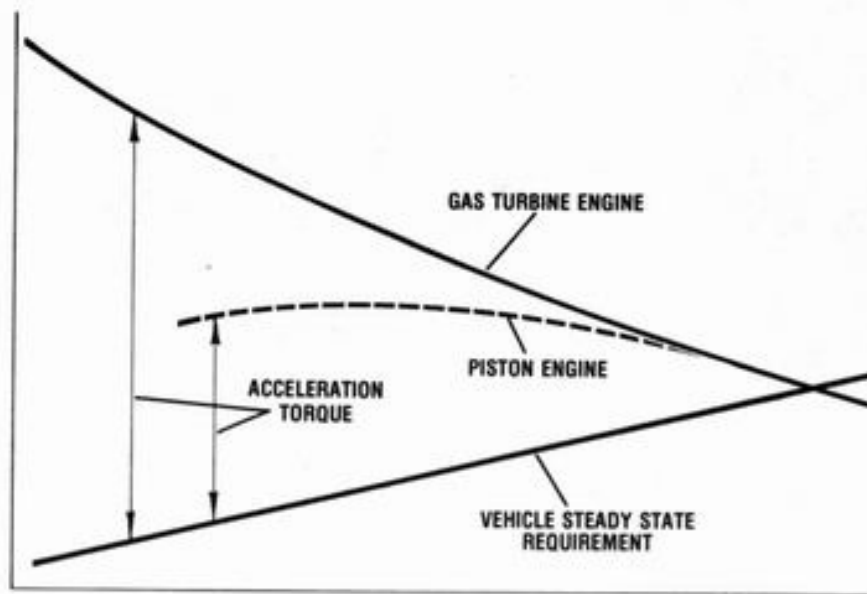

COMPARISON OF TORQUE CHARACTERISTICS

At idle, the speed of the compressor and its turbine wheel in current engines is about 30,000 rpm, and the speed of the car-driving turbine wheel is zero when the vehicle is standing still. When the car is in motion, the compressor and its turbine wheel can operate at speeds above 60,000 rpm and the car-driving turbine can rotate at speeds in excess of 70,000 rpm. The high rotational speeds of the power turbine are geared down in the engine to a usable speed for driving the wheels of the car.

From the burner through the turbine wheels, there is a drop in temperature and pressure of the gases, but the gases still retain large amounts of heat which would be wasted if merely allowed to escape through the exhaust pipe. So a device for salvaging the heat energy is placed in the path of the out-rushing gases. This component is a regenerator, a form of heat exchanger. It recovers heat from the hot exhaust gases and transfers this potential energy to the high pressure air flowing from the compressor to the burner, reducing the burner heat rise requirement. This regenerator is the principal feature which differentiates an automotive gas turbine from an aircraft turbine.

One of the exceptional features of the automotive gas turbine is that it will operate satisfactorily on a wide range of fuels without engine adjustments. This includes such fuels as unleaded gasoline, kerosene, diesel fuel, JP-4 jet fuel, and alcohol.

Another exceptional feature is the turbine's torque characteristic. In a car, the turbine's torque is greatest at breakaway from a standing position and decreases as the car speed increases where it is less necessary. This contrasts with the piston engine's torque characteristic, which builds to a maximum in the mid-speed range and then declines.

The gas turbine's potential as an automotive power plant, its capability to operate on a wide range of fuels, and its exceptional torque characteristics have played key roles in its continued development by Chrysler. Use of the engine in an automotive application became a reality in early 1954 when it was used in the first Chrysler-built turbine vehicle.



1954 PLYMOUTH TURBINE CAR GETS A PROVING GROUNDS WORKOUT

THE FIRST TURBINE CAR

March 25, 1954, was a very important date in automotive gas turbine history: Chrysler Corporation disclosed the development and successful road testing of a 1954 production model Plymouth sport coupe powered by a gas turbine engine. This car was on display from April 7 through 11 at the Waldorf-Astoria Hotel in New York City. On June 16, 1954, it was demonstrated publicly at the dedication of the Chrysler Engineering Proving Ground near Chelsea, Michigan. This car marked the first attempt by an American automotive firm to install a gas turbine engine in a production automobile.

The engine was rated at 100 shaft horsepower (74.6 kW). Although built essentially as a laboratory development tool, it was considered to be a "milestone in automotive power engineering" because it embodied solutions to two of the major problems long associated with vehicular gas turbines -- high fuel consumption and scorching exhaust gas.

The key feature which contributed to removing these technical barriers was the revolutionary new heat exchanger, or regenerator. It extracted heat from the hot exhaust gases, transferred this energy to the compressed air, and thus reduced the burner's job of raising the gas temperature. The result was conservation of fuel as well as lower exhaust temperatures.

A gas turbine engine without a regenerator requires several times the amount of fuel used in a regenerator-equipped engine.

The regenerator also reduced the exhaust gas temperature from about 1200° F (650° C) at full engine power to a safe level of less than 500° F (260° C). Even more important, at idle the temperature was reduced to 170° F (77° C). By the time the gases pass through the exhaust ducts to the atmosphere, the temperature was reduced even further.

Even with these breakthroughs, a great deal of work and many development problems still remained. On the date of the original turbine disclosure (March 24, 1954), Chrysler Corporation stated: "Whether we ultimately shall see commercial production of gas turbines for passenger cars depends on the long-range solution of many complex metallurgical and manufacturing problems. There is no telling at this time how long it will take to solve these problems."

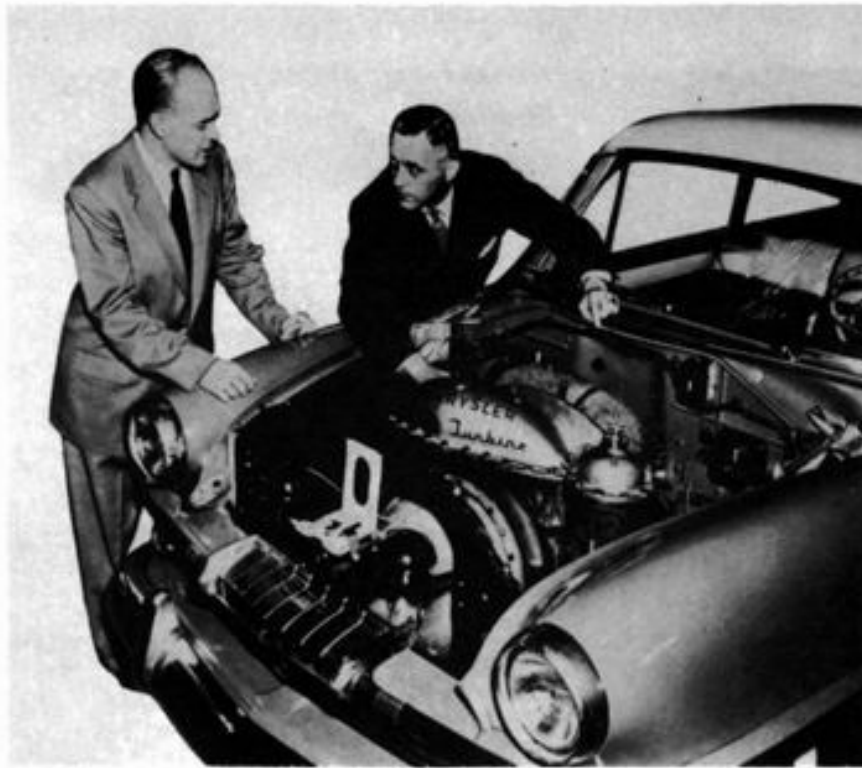

TURBINE ENGINE FITS NEATLY INTO 1954 PLYMOUTH

Almost a year later, the same basic engine was installed in a 1955 Plymouth. This car, although never displayed at public exhibits, was used for driving evaluation tests on Detroit area streets.



DETROIT TRAFFIC TEST FOR 1955 TURBINE



1956 TURBINE SPECIAL EN ROUTE CROSS-COUNTRY

In March 1956, another historic event took place -- the first transcontinental journey of an automobile powered by a gas turbine engine.

This turbine car, a four-door 1956 Plymouth sedan, a standard production model in every respect except for the revolutionary Chrysler-developed power plant, departed from the Chrysler Building in New York City on March 26. On March 30, 4 days and 3,020 miles (4 860 km) later, it completed its cross-country endurance test when it arrived at the City Hall in Los Angeles, California. The purpose of the run was to evaluate the turbine's durability, acceleration, fuel economy, control in traffic, action on steep grades, and operation under various climatic conditions. It marked another Chrysler Corporation "first" in the automotive record books and was considered a successful test.

Over the entire trip, fuel economy averaged approximately 13 mpg (18 L/100 km) using mostly unleaded gasoline and some diesel fuel. The run was interrupted only twice for minor repairs which did not involve the basic turbine engine (a faulty bearing in the reduction gear and an intake casting were replaced). The engine itself and its basic components performed very well and without failures of any kind.

This experimental turbine engine was essentially the same as the one tested previously in the 1954 Plymouth. However, it reflected progress in the following major points: parasitic seal and bearing friction losses were reduced; expensive ball and roller bearings were replaced with sleeve bearings on the high speed shafting; the combustion system was improved; and engine controls were developed further. Automatic controls then allowed the driver to operate the turbine just as he would a conventional automobile.

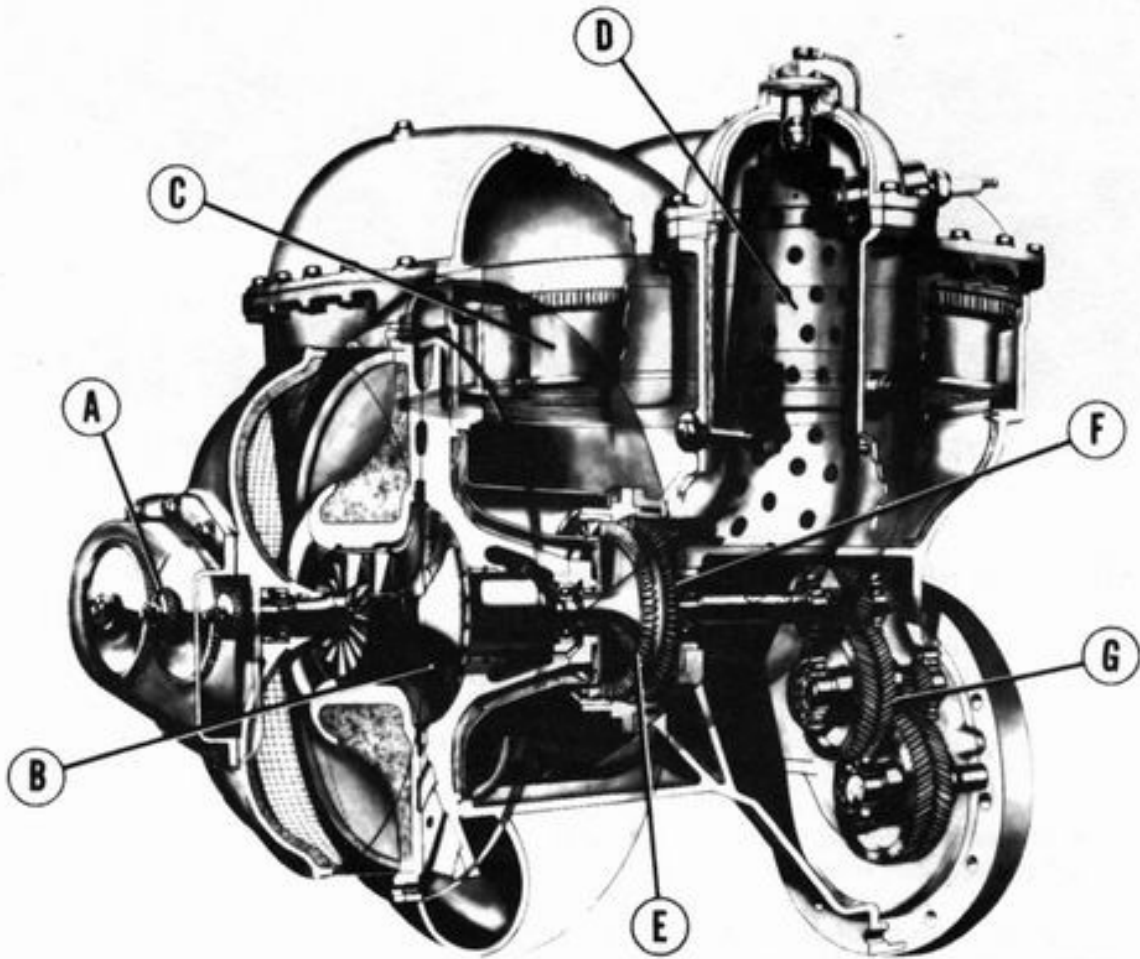

MAIN COMPONENTS OF THE FIRST GENERATION GAS TURBINE ENGINE

(A) accessory drive gears; (B) compressor impeller; (C) regenerator; (D) combustion chamber; (E) first-stage turbine, which drives the compressor impeller and accessories; (F) second-stage turbine, which supplies power to the transmission; and (G) double-stage reduction gearing to the transmission.



1959 PLYMOUTH TURBINE SPECIAL READY FOR ROAD EVALUATION

THE SECOND GENERATION TURBINE ENGINE

Basing their calculations on extensive test data and performance results of the 1956 cross-country trip, Chrysler engineers designed and developed a second engine. After extensive laboratory tests, it was installed in a standard production 1959 Plymouth four-door hardtop. In December 1958, this Turbine Special made a 576-mile (927 km) test run from Detroit to New York. The results showed significant improvements in fuel economy. This second generation turbine (also a laboratory development tool) operated in the 200 hp (149 kW) range; and, although it was improved in almost every respect, two areas were particularly outstanding -- efficiency and materials.

Three major engine components (compressor, regenerator, and burner) showed significant improvements in operating efficiency. The compressor efficiency was brought up to 80 percent, a 10 percent increase. The regenerator or heat exchanger unit at that time reclaimed almost 90 percent of the heat energy in the exhaust gas whereas peak efficiency in the 1956 cross-country run had been around 86 percent. Burner efficiency was also improved so that it was approaching the point of ideal combustion.

Less apparent, but fully as important as the engine design advances, was the progress in turbine metallurgy. Prior to this time, automotive turbine metals were similar to those used in aircraft jet engines. Although these existing materials were certainly adequate for test engines, they would not be suitable for automotive production for two key reasons: cost, and the simple fact that neither production capacity nor the available world supply of the required alloying materials could support such a program.

Through Chrysler metallurgical research, new materials were developed which did three things:

- Contained lower amounts of relatively expensive elements
- Could be fabricated by conventional means
- Had excellent resistance to heat and oxidation at elevated temperatures.

Applications for these new materials were combustion chamber liners, turbine wheels and blades, etc.

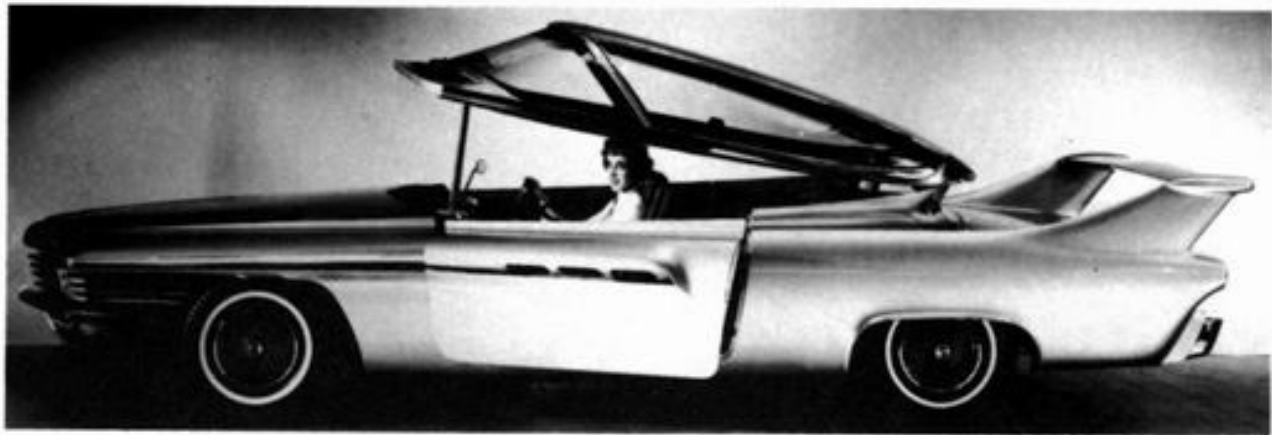

TURBOFLITE — ADVANCED POWER — ADVANCED STYLING

THE THIRD GENERATION TURBINE ENGINE

Encouraged by the previous progress, Chrysler engineers designed the third generation turbine, called the CR2A, and introduced it in three different vehicles. The initial showing was to newsmen on February 28, 1961. The vehicles were displayed publicly in Washington, D.C. March 5-9, 1961, in conjunction with the Turbine Power Conference of the American Society of Mechanical Engineers, co-sponsored by the Department of Defense.

The first of these gas turbine vehicles was an experimental sports type car called the "Turboflite" (shown above). In addition to the engine, other advanced ideas of the car were the retractable headlights, a deceleration air-flap suspended between the two stability struts, and an automatic canopied roof. This "idea" car received wide public interest and was shown at auto shows in New York City, Chicago, London, Paris, etc.

The second of the vehicles was a 1960 Plymouth which was standard in every respect except for the engine and minor exterior styling modifications.

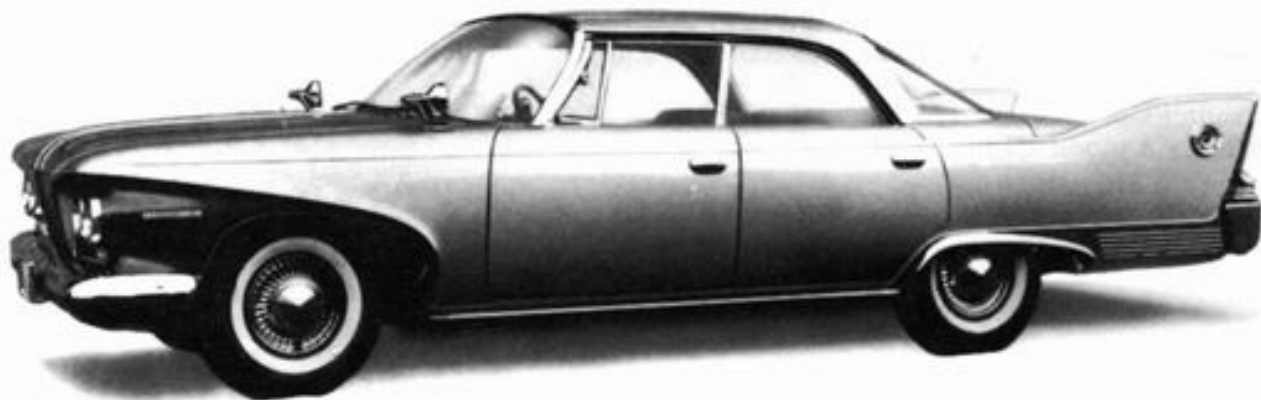

1960 TURBINE-POWERED PLYMOUTH



TURBINE POWER FOR 1960 DODGE TRUCK

The final member of this trio was a two-and-a-half-ton Dodge truck which was a standard production vehicle -- except for its gas turbine engine. This application demonstrated the turbine's versatility and adaptability because the engine in this truck was basically the same as those in the passenger cars.

After months of test and development work, a third generation gas turbine engine was also installed in a modified 1962 Dodge.



COAST-TO-COAST TEST VEHICLE — 1962 DODGE TURBO DART

Called the Dodge Turbo Dart, styling modifications to the car were adapted to reflect its radically different power plant. The bladed wheel motif of the grille and wheel covers reflected the appearance of the vital components of the gas turbine.

The car left New York City on December 27, 1961, to begin a coast-to-coast engineering evaluation. After travelling 3,100 miles (5 000 km) through snowstorms, freezing rain, sub-zero temperatures, and 25 to 40 mile per hour (40 to 65 km/h) head winds, it arrived in Los Angeles on December 31.

The turbine not only lived up to all expectations but had exceeded them. An inspection showed every part of the engine to be in excellent condition. Fuel economy was consistently better than that of a conventional car which had traveled with the turbine car and was exposed to the same conditions.

SPECIFICATIONS OF CHRYSLER CORPORATION'S THIRD GENERATION GAS TURBINE ENGINE

GENERAL

Type: Regenerative gas turbine

*Rated Output: Power - 140 bhp (104 kW) @4,570 rpm output shaft speed
Torque - 375 lb-ft (508 N·m) @zero rpm output shaft speed

Weight: 450 lb (204 kg)

Basic Engine Dimensions (without accessories): Length - 27 in. (686 mm)
Width - 35 in. (889 mm)
Height - 27 in. (686 mm)

With automotive accessories in place, the over-all length is: 36 in. (914 mm)

Fuels: Unleaded gasoline, diesel fuel, kerosene, JP-4, etc.

COMPONENTS

Compressor Section

- Single stage
- Centrifugal; 4:1 pressure ratio
- 14 channel diffuser
- Single scroll collector

Turbine Section

First Stage

- Single stage axial
- Fixed nozzle vanes

Second Stage

- Single stage axial
- Variable nozzle vanes

Regenerator: Type - Single rotating disk
Effectiveness - 90%

Burner: Type - Single can, reverse flow
Effectiveness - 99%

*DESIGN POINT CHARACTERISTICS

Maximum Gas Generator Speed - 44,600 rpm
Maximum Second Stage Turbine Speed - 45,700 rpm
Maximum Output Speed (after reduction gears) - 5,360 rpm
Maximum Regenerator Speed - 17 rpm
Compressor Air Flow - 2.2 lb/s (1.0 kg/s)
First Stage Turbine Inlet Temperature - 1700° F (927° C)
Exhaust Temperature (full power) - 500° F (260° C)

*Ambient conditions: Temperature - 85° F (29.5° C)

Barometric Pressure - 29.92 in. Hg
(101.3 kPa)

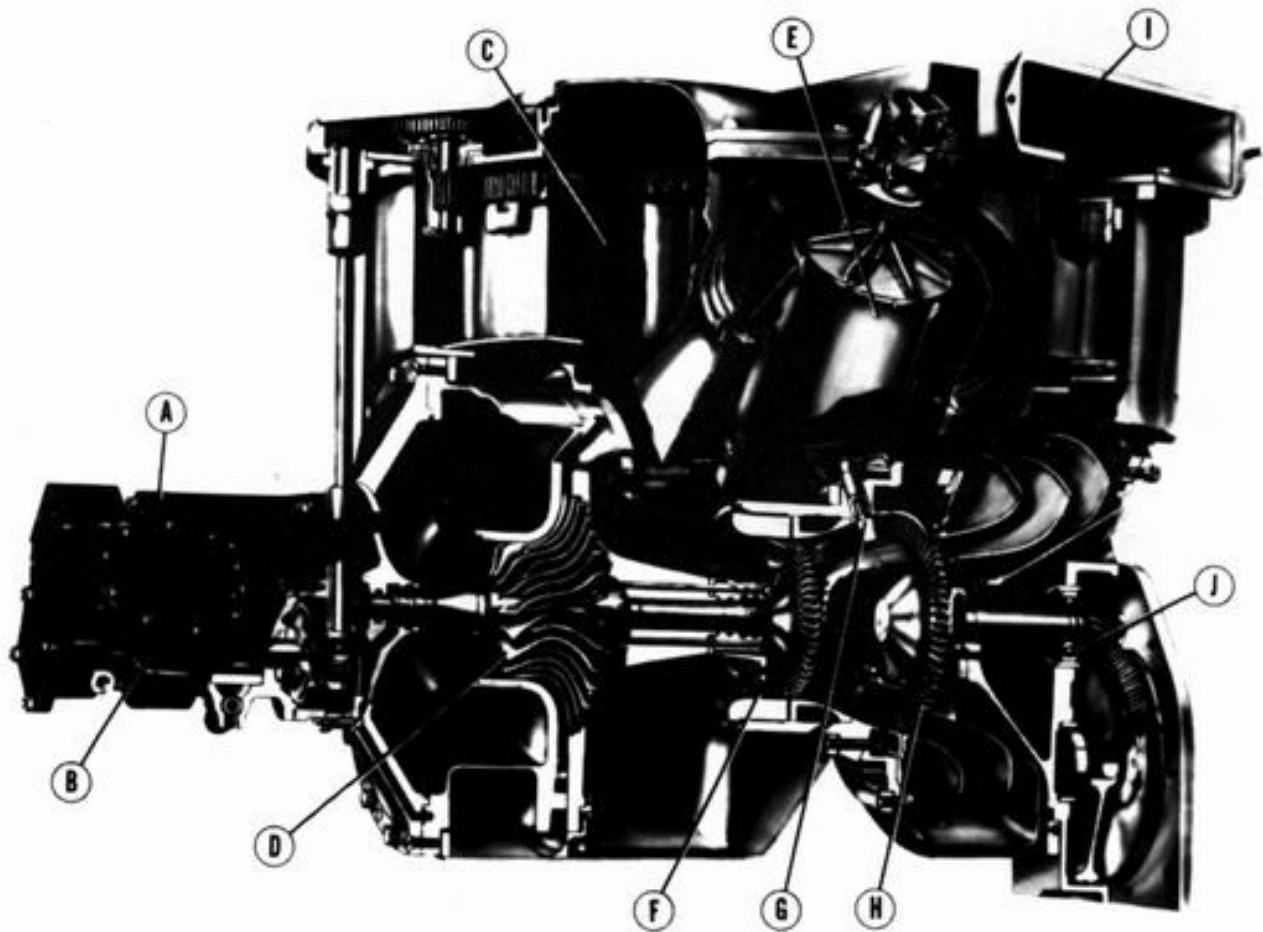

MAIN COMPONENTS OF THE THIRD GENERATION GAS TURBINE ENGINE

(A) the starter-generator; (B) fuel pump; (C) regenerator; (D) compressor impeller; (E) combustion chamber; (F) first-stage turbine, which drives the compressor impeller and accessories; (G) variable second-stage nozzle; (H) second-stage turbine which supplies power to the driveshaft; (I) one of two exhaust outlets; (J) single-stage helical reduction gear of 8.53-to-1 ratio which reduces power turbine rpm of 39,000 to 45,730, to a rated output speed of 4,570 to 5,360 rpm.

The key to the excellent performance and economy of the third-generation gas turbine (called the CR2A) was its new variable turbine nozzle mechanism.

The automatic second stage turbine nozzles provided optimum performance throughout the entire operating range of the engine. Thus, economy, performance, or engine braking could be maximized as required by the driver. For example, one area of performance is what is termed acceleration lag -- the time it takes the compressor section to reach operating speed, which would provide maximum power, after the accelerator pedal is depressed. The first generation turbine engine had an acceleration lag of 7 seconds from idle to full-rated output;

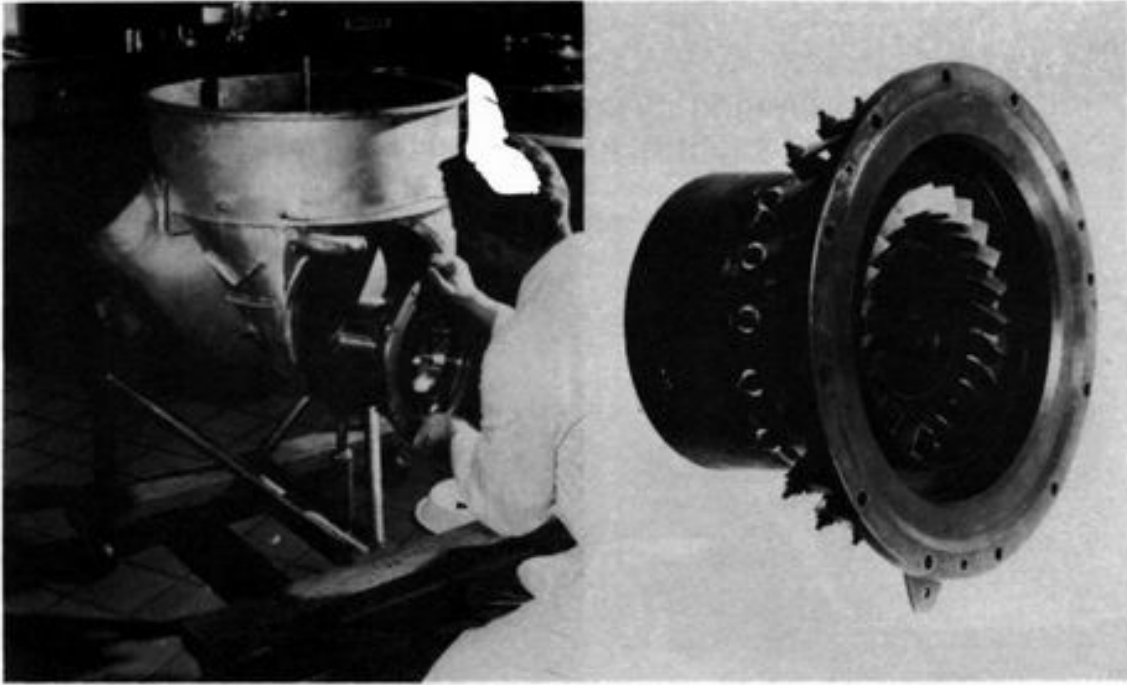

VARIABLE NOZZLE MECHANISM

Variable nozzle mechanism is installed by a research engineer in the rear of the Third Generation turbine engine housing (left). The nozzle mechanism (right) acts in shutter fashion to provide engine braking, improve acceleration and increase fuel economy by controlling and directing the angle of the jet stream to the power turbine blades.



1962 TURBINE TWINS



STOPOVER POINTS ON CONSUMER REACTION TOUR

the second generation engine required 5 seconds, while the third generation engine required less than 2 seconds to accomplish the same performance.

Another experimental turbine-powered car -- the Plymouth Turbo Fury -- joined the Dodge Turbo Dart, and the two turbine-powered cars began extensive consumer reaction tours at dealerships throughout the country in cities such as Los Angeles, San Francisco, Kansas City, St. Louis, Cleveland, Detroit, Chicago, etc. Two other turbine cars, a second Dodge and a second Plymouth, were added during the month of April in order to expand coverage of the tours. All four cars were powered by versions of the third generation turbine engine.

The tour schedule was similar in each area. When the cars arrived in a given city, they were first displayed to members of the local press. The press events involved explaining the turbine and answering questions, giving each newsman a ride in one of the cars and, in some cases, staging special tests. After members of the press had viewed the cars, they were then displayed at various dealerships.

One of the key reasons for these tours and exhibits was to elicit and evaluate consumer reactions to the turbine. The cars were shown at Plymouth and Dodge dealerships in approximately 90 major cities in the United States and Canada.

During this time hundreds of thousands of people came to see the turbine vehicles, and public interest was intense and serious. When asked, "If this car were offered for sale to the motor-ing public, do you think you would buy one?", 30 percent of the turbine viewers said, "Yes," they would definitely buy one and 54 percent answered they would think seriously of buying one.



GEORGE J. HUEBNER, JR. RECEIVES AWARD FOR GAS TURBINE LEADERSHIP

As a result, on February 14, 1962, Chrysler Corporation announced that it would build 50 to 75 turbine-powered passenger cars which would be made available to selected users by the end of 1963. Typical motorists would be offered an opportunity to evaluate turbine cars under a variety of driving conditions.

On February 14, 1962, in Chicago, Chrysler Corporation exhibited another gas turbine vehicle -- the Dodge Turbo Truck. This medium-duty truck (also equipped with the third generation experimental engine) had just completed a 290-mile (465 km) test run from Detroit to Chicago.

From February 17 through 25, three gas turbine-powered vehicles (the Plymouth, Dodge, and Dodge Truck) were exhibited at the Chicago Automobile Show.

On March 7, 1962, George J. Huebner, Jr., then Executive Engineer of Research for Chrysler Corporation, received an award from the Power Division of the American Society of Mechanical Engineers "for his leadership in the development of the first automotive gas turbine suitable for mass-produced passenger automobiles." It was the first such award ever given to an automotive engineer.



A COMPLETELY NEW CAR

THE FOURTH GENERATION TURBINE ENGINE

May 14, 1963, was an eventful day in the history of automotive design -- the Chrysler Corporation Turbine Car was unveiled to newsmen at the Essex House in New York City. On the same day, a ride-drive program for the press was held on a 2-1/2 mile (4 km) course at the Roosevelt Raceway on Long Island. On May 15, the car was viewed at the Waldorf-Astoria Hotel in New York City by Chrysler's Metropolitan New York dealers.

These events signaled the public launching of Chrysler Corporation's program of building 50 turbine-powered test cars and placing them in the hands of typical drivers for evaluation in everyday use.

This program was an outstanding point in the history of turbine vehicles for two reasons: it was the first time any company had committed itself to build a substantial number of gas turbine automobiles; and it was the first time turbine-powered automobiles would be driven and evaluated by private individuals outside the Corporation.

The Turbine Car was a completely new automobile. Since the sole purpose was to determine the reaction of typical American drivers to turbine-powered vehicles, the engine was placed in a family-type car designed for everyday use. This formed a familiar evaluation background for the driver. The styling theme provided an exciting setting for the vehicle itself, creating an over-all impression of fresh styling appeal with strong emphasis on a contemporary and luxurious appearance. Ornamentation was based on the bladed turbine motif which is characteristic of the engine. The interior featured a full-length center console and extensive use of leather.



REAR VIEW EMPHASIZES AERODYNAMIC STYLING

This limited-production Turbine Car was built in one body style only -- a 4-passenger, 2-door hardtop. The exterior and interior color was "turbine bronze." Power steering, power brakes, power window lifts, automatic transmission, and all other available equipment were standard.

The turbine power plant for the car was an entirely new design, more advanced in concept than the previous Chrysler turbines, and more adaptable to production techniques. It was Chrysler Corporation's fourth generation turbine power plant design. Its most obvious feature was a new configuration with two regenerators rotating in vertical planes (one on each side) and a centrally located burner. Compared with the previous model CR2A, the new engine was more lively, lighter, more compact, and quieter.

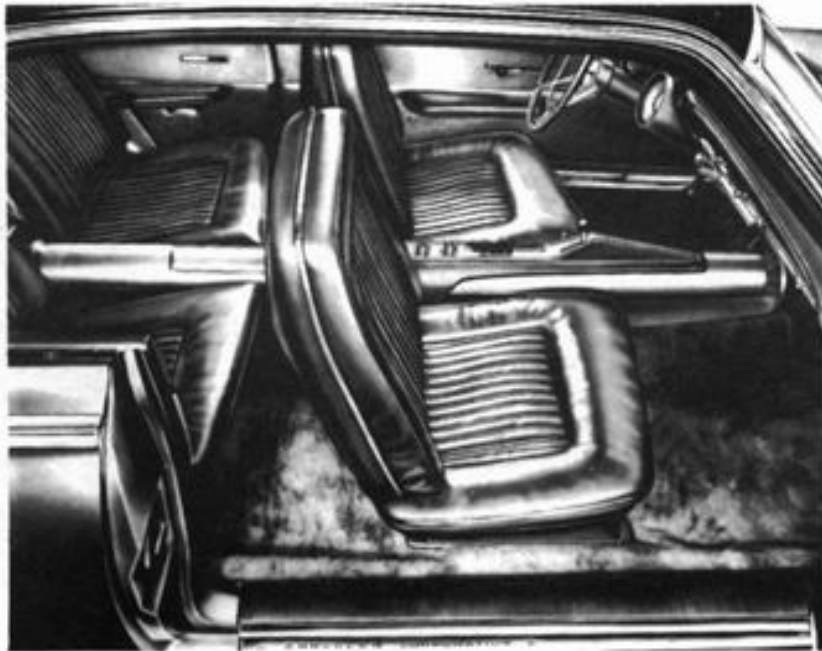

LUXURIOUS INTERIOR APPOINTMENTS OF THE TURBINE CAR

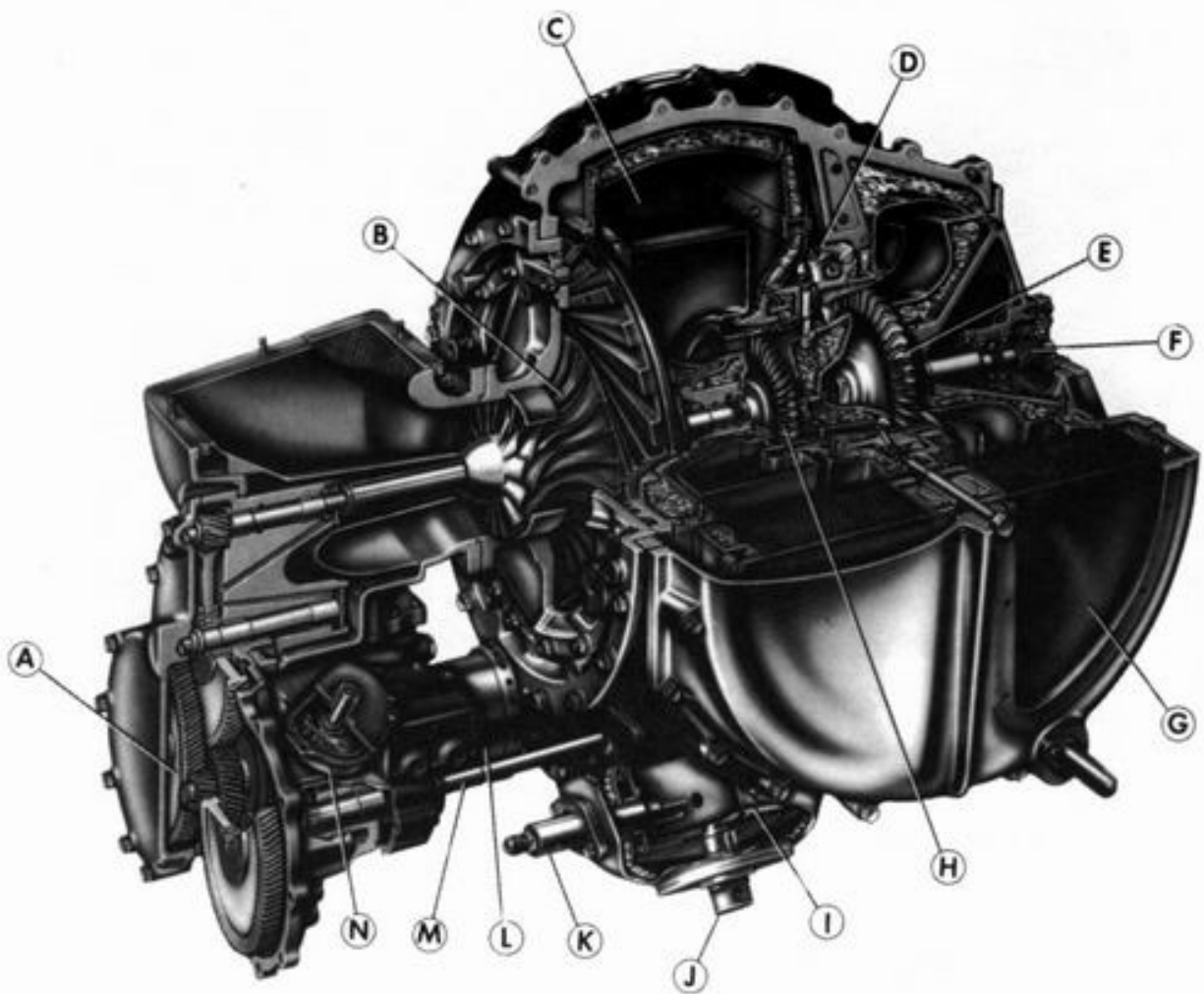

MAIN COMPONENTS OF THE FOURTH GENERATION GAS TURBINE ENGINE

(A) accessory drive; (B) compressor; (C) right regenerator; (D) variable nozzle unit; (E) power turbine; (F) reduction gear; (G) left regenerator; (H) compressor turbine; (I) burner; (J) fuel nozzle; (K) igniter; (L) starter-generator; (M) regenerator drive shaft; (N) ignition unit.

SPECIFICATIONS OF CHRYSLER CORPORATION'S FOURTH GENERATION GAS TURBINE ENGINE

GENERAL

Type: Regenerative gas turbine

Rated Output: Power - 130 bhp (97 kW) @3,600 rpm output shaft speed
Torque - 425 lb-ft (576 N·m) @zero rpm output shaft speed

Weight: 410 lb (186 kg)

Basic Engine Dimensions (without accessories): Length - 25 in. (635 mm)
Width - 25.5 in. (648 mm)
Height - 27.5 in. (699 mm)

With current accessories in place, the over-all length is: 35 in. (889 mm)

Fuels: Unleaded gasoline, diesel fuel, kerosene, JP-4, etc.

COMPONENTS

Compressor Section

- Single stage
- Centrifugal; 4:1 pressure ratio
- 28 channel diffuser
- Plenum collector

Turbine Section

First Stage

- Single stage axial
- Fixed nozzle vanes

Second Stage

- Single stage axial
- Variable nozzle vanes

Regenerator: Type: - Two rotating disks
Effectiveness - 90%+

Burner: Type: - Single can, reverse flow
Effectiveness - 99%

*DESIGN POINT CHARACTERISTICS

Maximum Gas Generator Speed - 44,600 rpm
Maximum Second Stage Turbine Speed - 45,700 rpm
Maximum Output Speed (after reduction gears) - 4,680 rpm
Maximum Regenerator Speed - 22 rpm
Compressor Air Flow - 2.2 lb/s (1.0 kg/s)
First Stage Turbine Inlet Temperature - 1,700° F (927° C)
Exhaust Temperature (full power) - 525° F (274° C)
Exhaust Temperature (idle) - 180° F (82° C)

* Ambient conditions: Temperature - 85° F (29.5° C)
Barometric Pressure - 29.92 in. Hg
(101.3 kPa)

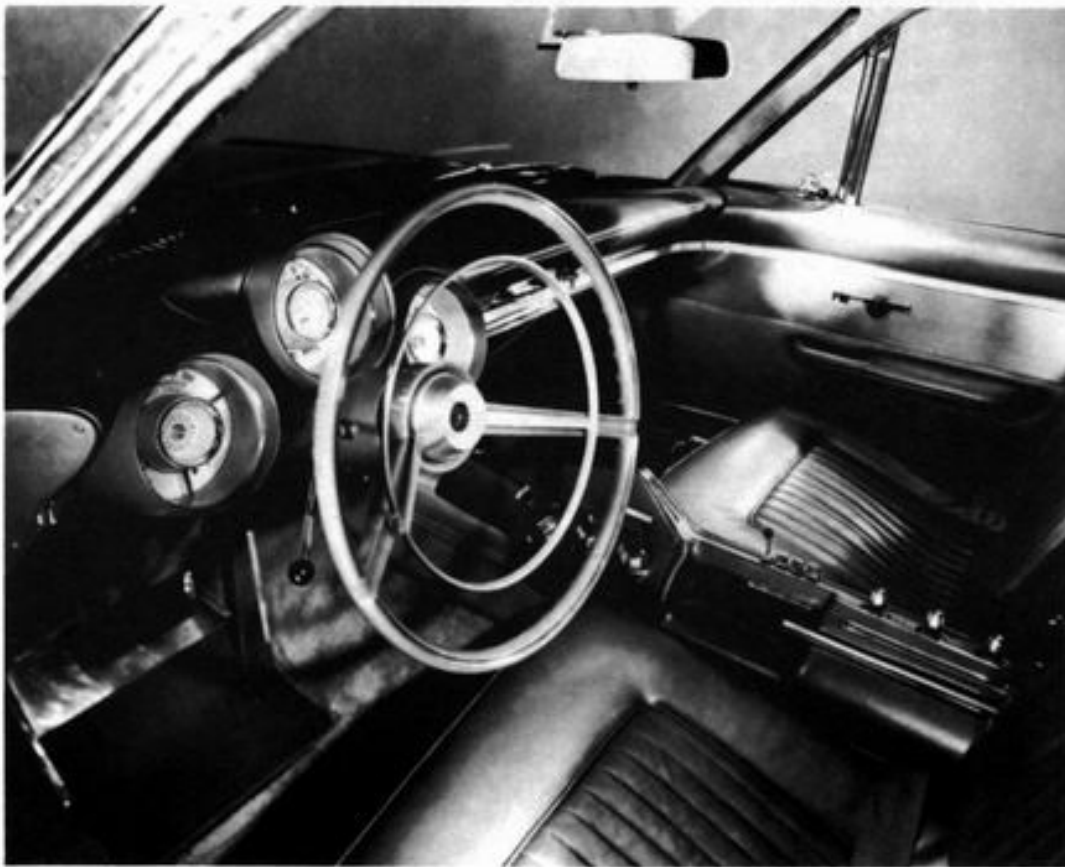

INSTRUMENTATION AND CONTROLS

The operation of the Turbine Car is much the same as that of a car with a piston engine and an automatic transmission except that the normal "Neutral" position is replaced with an "Idle" position.

To Start - Place the transmission shift lever in the "Idle" location and push down to engage the "Park/Start" position. Turn the ignition key to the right and release it. Starting is automatic. Within a few seconds, the inlet temperature and tachometer gauges on the instrument panel will read about 1200° F (650° C) and 22,000 rpm, respectively, indicating that the engine has started and is at idle operation.

To Drive - Place the transmission in "Low", "Drive", or "Reverse" (as with a conventional car), release the parking brake, and the car is ready to drive.

To Park - Bring the car to a complete stop, place the transmission lever in the "Idle" location and push it down to engage the "Park/Start" position, apply the parking brake, and turn the ignition key to the "off" position.

The performance and economy of the Turbine Car as demonstrated in proving ground and highway tests were comparable to a conventional car powered by a standard V-8 engine. The engine operated satisfactorily on diesel fuel, kerosene, unleaded gasoline, JP-4 (jet fuel), and mixtures thereof. Even more interesting, it was possible to change from one of these fuels to another without any changes or adjustments to the engine. The turbine engine has other advantages, too (listed in the INTRODUCTION), and one of the objectives of the user evaluation program was to see just how much these advantages mean to the average motorist.



FORMER CHRYSLER BOARD CHAIRMAN LYNN TOWNSEND VIEWS THE FIRST TURBINE CAR ASSEMBLY LINE

The Chrysler Corporation Turbine Cars were built at a rate of one per week until the last of the 50 cars was completed in October 1964. The special facilities for building these limited production test cars were located at Chrysler Corporation's Engineering Research Laboratories in Detroit. At the assembly area, the Chrysler-designed car bodies, which were built by Ghia of Italy, were lowered onto the new engines and chassis components. The turbine engines were built and tested at Chrysler's Research Laboratories.

The objective of the user evaluation program was to test consumer and market reaction to turbine power and to obtain service data and driver experience with the turbine cars under a wide variety of conditions. Each selected user drove one of the cars for a period up to 3 months under a no-charge agreement. The cars were then reassigned to other users to provide a broad consumer sampling base. In total, the cars were distributed to 203 motorists on a rotating system over a 2-year period, from October 29, 1963, to October 28, 1965. The last user completed her 3-month use period on January 28, 1966.

By retaining ownership of the cars, Chrysler kept in close touch with their performance and with the service experience on the engines. Also, Chrysler engineers were able to incorporate advances and modifications resulting from Chrysler's continuing research program. A period of 3 months was selected because it was felt this would give each driver ample time to try our turbine power under a variety of conditions. Limiting each driver to this period made it possible to obtain the reactions of over 200 users in a short time.

Users of the turbine-powered passenger cars were selected by the accounting firm of Touche, Ross, Bailey, and Smart. Under the user selection procedure, Chrysler gave the accounting firm the date and metropolitan area location of each planned delivery, which was geared to the turbine production schedule. Random selection of user candidates for each location was then made by the accounting firm according to the selection and distribution criteria specified by Chrysler to meet market test objectives.

The basic qualifying requirements were that a candidate owned a car (or, be a member of a household in which a car was owned by the head of the household) and had a valid driver's license.

Turbine candidates were picked as follows:

- From Chrysler's letter inquiry file of 30,000 names. These applications were in the form of unsolicited letters from people in hundreds of cities in all 50 states (and 15 countries). Requests ranged from that of a 12-year-old boy asking that his father be given a car to that of an 83-year-old retiree.
- From 128 major population centers of the 48 contiguous states. Chrysler specified this to assure a high degree of market exposure to turbine-powered vehicles and to test the cars in a variety of geographic areas and in all kinds of weather and terrain. The number of trials in each population center was apportioned according to the number of cars owned in each area.
- In accordance with the make, price category, and age of the new and used cars owned by candidates at the time they wrote their letters to Chrysler. In this respect, the program intent was to select users whose car ownership pattern reflected the great variety of the types and ages of cars on the road today.

In return for the use of the turbine car, each user was asked to furnish Chrysler with the information needed for the market evaluation program. Chrysler handled the service, insurance, and other costs involved in the use of the turbine car. Each user bought the fuel for driving it. The user was also expected to maintain the physical appearance of the car, exercise reasonable care to protect it from damage, and supervise its use by others.

The world's first consumer delivery of a turbine car took place October 29, 1963, in Chicago. Mr. Lynn A. Townsend, former Board Chairman of Chrysler Corporation, presented the keys of the turbine car to Mr. & Mrs. Richard E. Vlaha of Broadview, a suburb of Chicago.



FIRST CONSUMER DELIVERY OF A TURBINE CAR



THE TURBINE CARS WERE EXPOSED TO A WIDE VARIETY OF CLIMATE IN THE PROGRAM

The experience of the user program indicated that the idea of turbine-powered passenger cars was capable of earning widespread consumer acceptance. Each user was interviewed within two weeks of the conclusion of his use period. Users generally were enthusiastic about the turbine car. Although it was expected that anyone who had free use of a new and unique automobile would have a favorable attitude toward it, interviewers were satisfied, after sufficient questioning, that it was the performance of the turbine engine itself that caused favorable reaction among users.

Many people expressed the conviction that gas turbine power plants would eventually replace conventional piston engines. Others, while enthusiastic about the car, said they thought that acceleration and fuel economy would have to be improved before turbine cars could be marketed successfully.

Three out of four singled out the smooth, vibrationless operation of the car as its principal advantage. They were impressed by this aspect of the turbine engine, and talked about a "gliding sensation" which was felt at all speeds, especially on long trips.

The second most important advantage was reduced maintenance. Although the users recognized that a 3-month test consisting of normal driving would not prove that an engine is exceptionally durable or maintenance-free, they generally assumed that the smaller number of moving parts would naturally lead to less need for periodic maintenance.

Another strong point of turbine engines, according to users, was starting ability. Regardless of the make and model year of the car each owned, users consistently considered the turbine car superior to others in providing fast, sure ignition.



ONE OF THE 22 WOMEN SELECTED IN THE USER'S PROGRAM

About one person in four expressed disappointment with fuel economy. This is attributed to the engine's inherently high idle fuel consumption and the fact that much fuel was used by frequent starts, stops, and idling while demonstrating the car for friends. Highway mileage, however, was excellent. Consequently, their over-all fuel consumption could not be considered a true measurement of the car's fuel mileage capability. In this area, Chrysler regarded its own proving ground and road test experience as more valid measurements of the turbine's actual fuel consumption potential.

In reacting to the sound of the turbine engine, users tended to contradict each other. For every person who complained about the noise level of the engine, there were three or four who liked the sound of turbine power. The car was described as immensely more quiet, especially at high speeds, than the conventional piston-powered automobile.

From an engineering standpoint, the program afforded an opportunity to observe and to judge the behavior of turbine engines under actual customer driving conditions -- the first time that automobile turbine engines were tested to such a wide extent under such circumstances. The turbine car user program provided an engineering record of over 1 million miles by 203 different drivers, men and women, old and young, in 48 states.

Chrysler was primarily interested in the life of engine parts and components, their performance and reliability, the degree and nature of maintenance required, and the amount of training desirable for service people.

Engineers were especially watching for problems that had not shown up in laboratory or proving ground tests. For example, the engines in the 50 test cars had a combined starter-generator which had performed well in previous testing, but during the user program it was found that the starter-generator brushes would not stand up to a combination of high altitude and low humidity. It was concluded that until further progress occurred in brush design or materials, the best solution was to have separate starter and alternator units.

The 1.1 million miles (1.8 million km) accumulated during the 50-car program have been a valuable direct source of information on the daily, over-the-road behavior of gas turbine engines and components. The program was useful in judging the potential value and acceptance of the gas turbine as an automobile power plant, and the lessons learned were useful in helping Chrysler engineers improve performance, reliability, life, and manufacturing methods.

An extremely beneficial aspect of the program was the experience gained in turbine engine maintenance and in the training of service personnel. For this program, Chrysler had five field service men and two supervisors who were charged with providing engine service and keeping track of the time during which engines could not be operated because of malfunction. The service required on 50 cars, scattered the length and breadth of the nation, was performed essentially by these five men.

During the early weeks of the program, operating time lost because of engine malfunction amount to about 4 percent. Eventually this was reduced to slightly more than 1 percent. Considering that many of the lost days included travel time for service men and shipping time for parts -- a situation that would not exist with a vehicle that is produced and sold in volume -- this was a remarkable record for an experimental engine out on its own for the first time.

The experience of the 50-car program indicated that training of mechanics in the maintenance and repair of gas turbines would not present unusual problems.

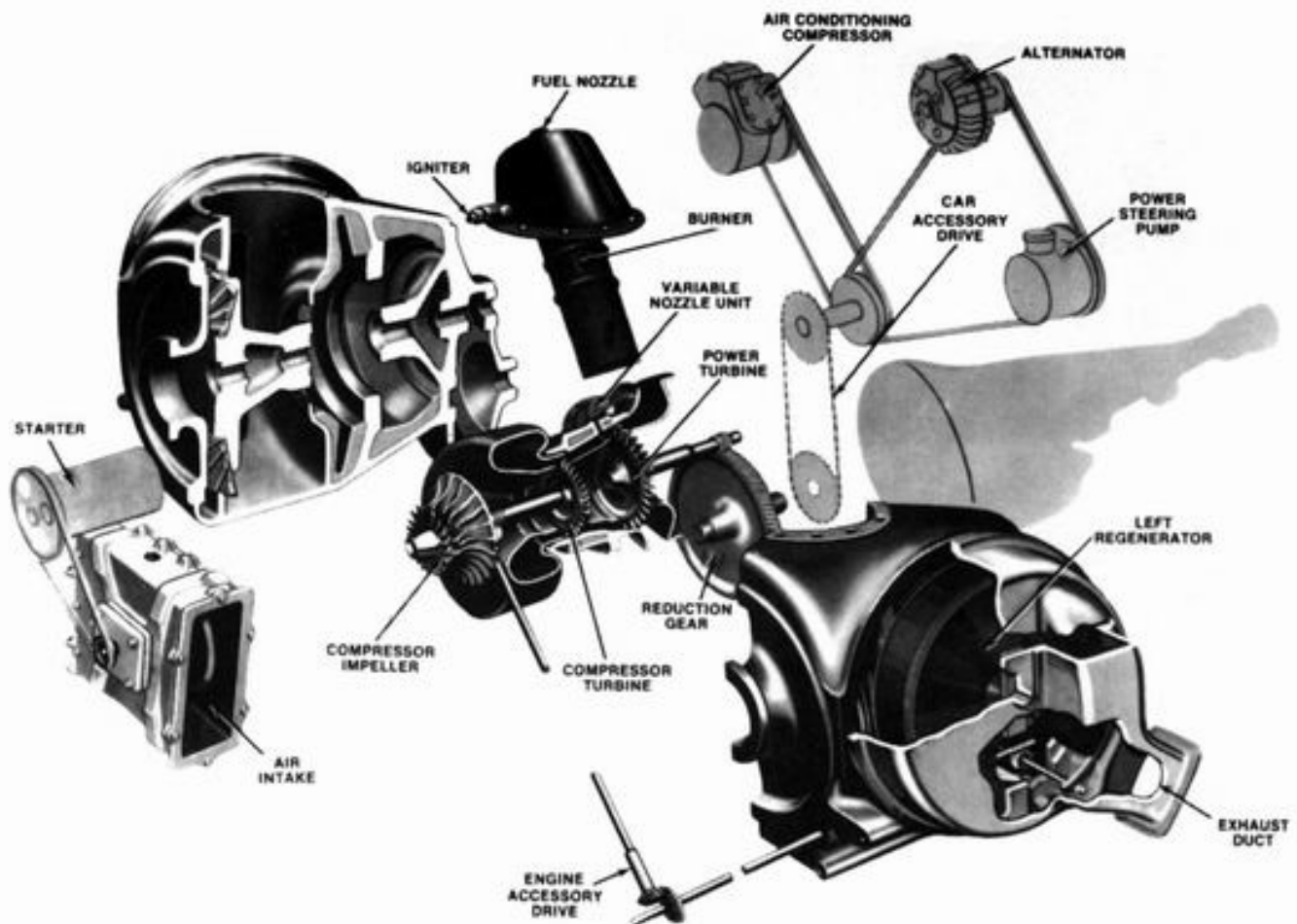

SIXTH GENERATION GAS TURBINE ENGINE

THE FIFTH AND SIXTH GENERATION TURBINE ENGINES

The fourth generation engine built for the 50-car user evaluation program met most requirements of smoothness and reliability, but consumers found its performance and economy were not comparable to that of contemporary piston engine-powered vehicles. In anticipation of consumer demand for a turbine engine with better fuel economy, tentative plans had been made for a limited production run of 500 1966 Dodge Charger Coupes utilizing a fifth generation engine. This engine, which was a modified version of the fourth generation engine, utilized larger regenerators and a higher cycle temperature for improved power and fuel economy.

However, the 500 car program was postponed because of economic conditions prevailing at the time and because studies revealed that substantial burner development was still required before this engine could meet strict requirements limiting emissions of oxides of nitrogen.

During this period, a sixth generation engine evolved. It utilized most of the fifth generation components, but was designed for development use. It incorporated a split accessory drive system, whereby car accessories like power steering and air conditioning were powered by the power turbine, while engine accessories, such as the fuel pump, were still run by the compressor turbine. This engine was also modified internally for improved engine braking and provided an excellent test bed for component life evaluation, noise reduction, and combustion system development.

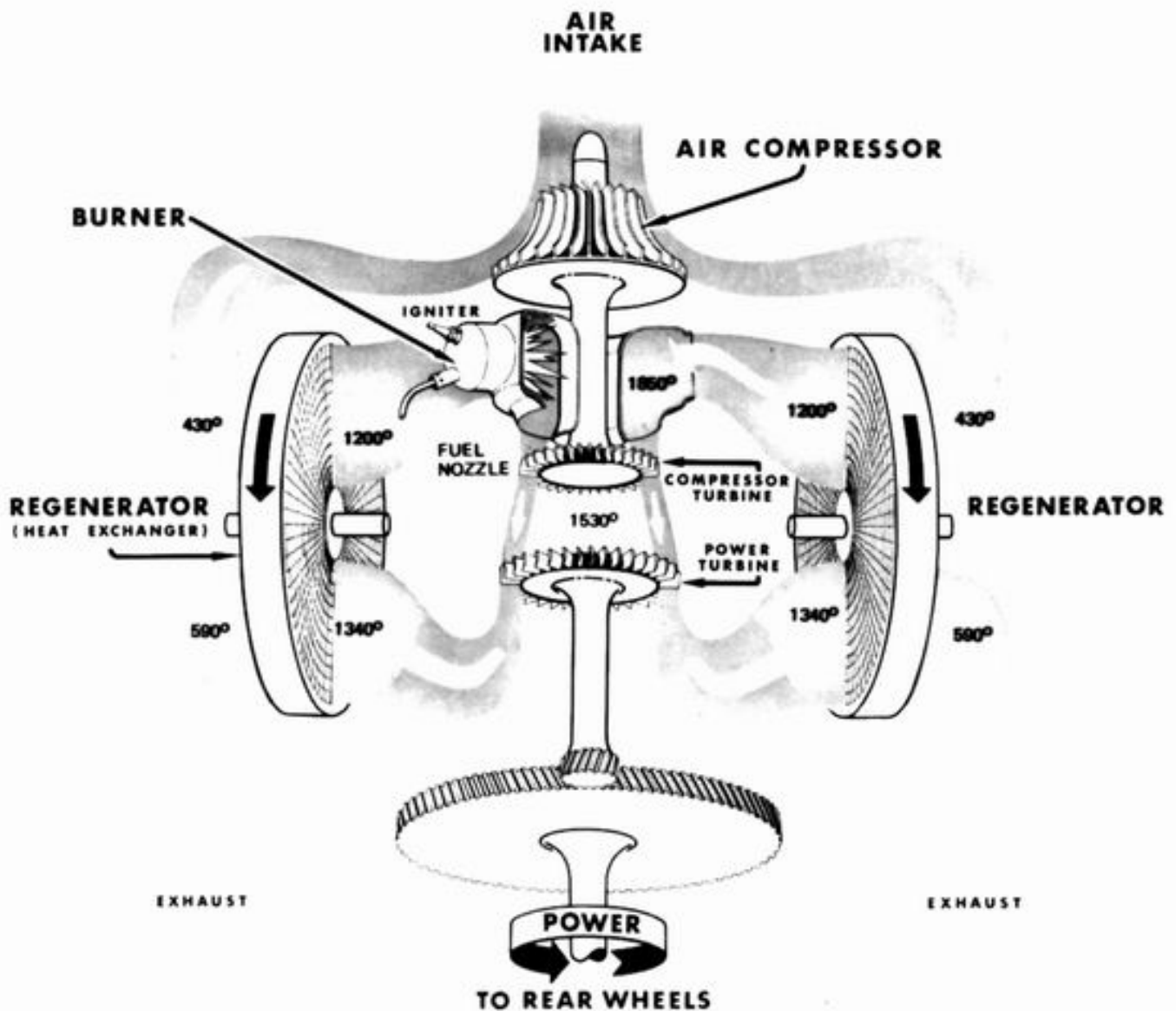

SIXTH GENERATION GAS TURBINE ENGINE

The sixth generation engine was installed in a 1966 Dodge Coronet which was used for engineering development work from 1966 until early 1973. This car was not displayed in public.

The sixth generation turbine engine delivered 150 horsepower (112 kW) and in terms of overall car performance, it was equivalent to a normally-carbureted V-8 spark ignition engine of approximately 380 CID (6.2 L) displacement. It was lighter in weight than the conventional engine, and characteristic of the turbine engine, it could operate on a variety of fuels.

In 1969, activity on the sixth generation turbine engine was greatly reduced because it became necessary to assign increasing numbers of engineers to research and development programs on emissions controls for conventional engines.



TURBINE POWERED 1966 DODGE CORONET



However, in view of the growing complexity of conventional engine emissions control systems and the low emission potential of the gas turbine engine, work was continued on low emission gas turbine burners.

Because of continuing turbine development progress, Chrysler Corporation won a competitively-bid Federal government contract from the U.S. Environmental Protection Agency (EPA) in November 1972. The goals of the gas turbine development program were modified to demonstrate an experimental gas turbine powered automobile which will accomplish these objectives:

- Meet advanced Federal emissions standards
- Have significantly improved fuel economy compared to earlier gas turbine-powered automobiles
- Be competitive in performance, reliability, and potential manufacturing costs with the conventional piston engine powered compact-size American car.

This contract was a milestone because it was the first time that EPA had ever awarded an advanced power system development contract to an automobile manufacturer.



**THIS TURBINE POWERED
1973 INTERMEDIATE CAR
WAS DELIVERED TO EPA IN 1973 FOR EVALUATION**



THE SEVENTH GENERATION TURBINE ENGINE

Since the awarding of the contract, sponsorship of the program has been transferred from the EPA to the Energy Research and Development Administration (ERDA) and then to the Department of Energy (DOE), which was formed in September 1977 to consolidate the various Federal energy-related efforts.

Chrysler Corporation's sixth generation gas turbine engine was selected as most representative of the automotive gas turbine state-of-the-art at the beginning of the program, and was selected as the baseline engine for use in the development program.

Using the baseline engine, Chrysler developed and evaluated systems and components to upgrade the engine. Some of the components and concepts which were to be evaluated included combustion systems; regenerator/seal systems; integral electronic control systems; alternate turbine wheel manufacturing methods; nozzle actuators; a "free" rotor; power augmentation, including variable inlet vanes and water injection; and other efficiency improvements. Some of the components and systems were developed by Chrysler while others were developed by other subcontractors. Concepts studied and developed which were new to the automotive gas turbines were power augmentation and a "free" rotor arrangement.

Power can be augmented by use of a water injection system and variable compressor inlet guide vanes. Under normal driving conditions the engine operates as a 104 hp (78 kW) engine and provides the higher fuel economy that is associated with lower powered engines. However, when maximum acceleration is required, performance can be increased to that of a 123 hp (92 kW) engine by use of water injection at the compressor inlet and by repositioning of the inlet guide vanes. In a gas turbine engine, power increases naturally with cooler ambient air temperatures; thus, the water injection system is needed to augment the engine power only when the ambient air temperatures exceed 60°F (15°C) so protection from freezing is not necessary.

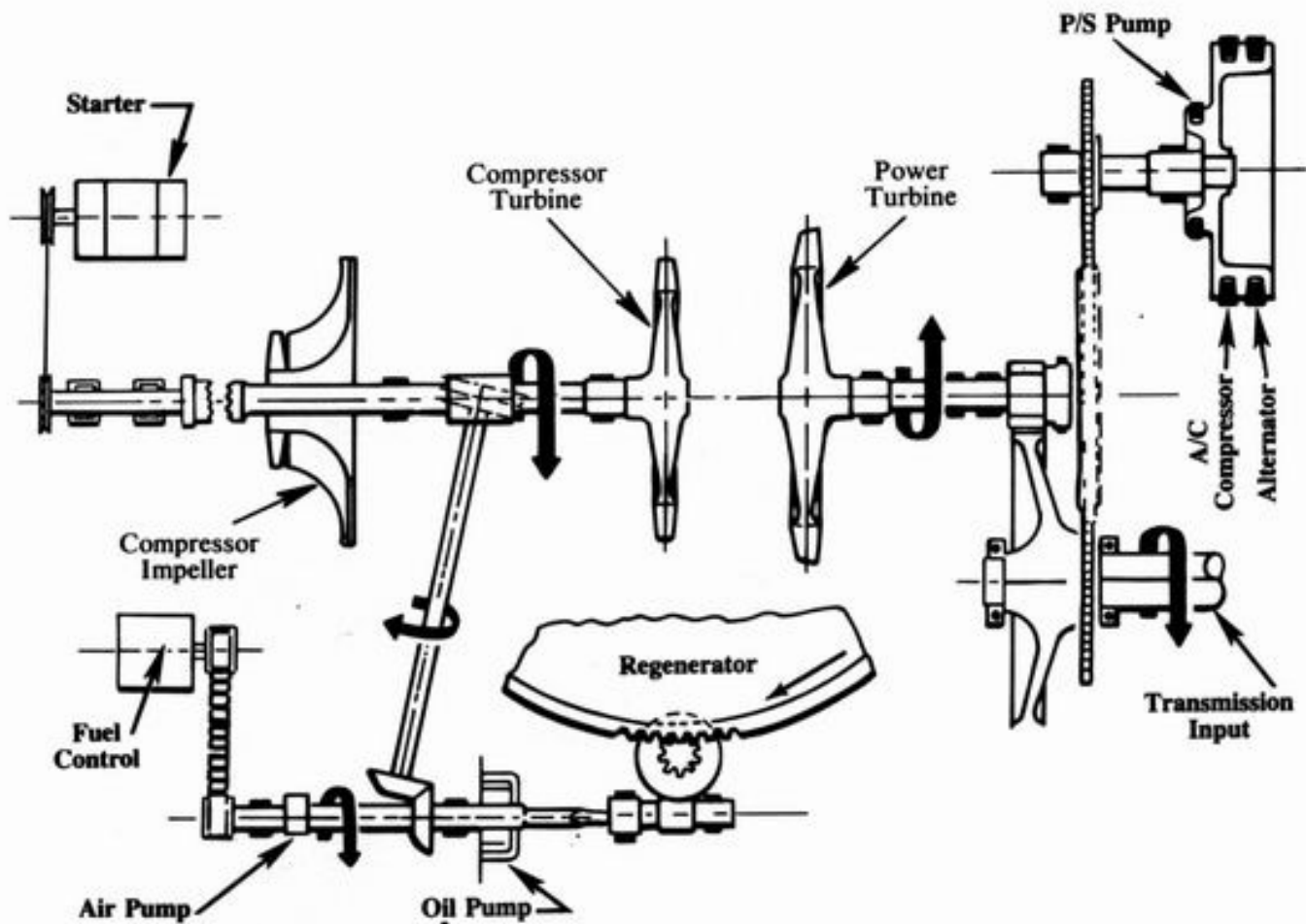

GEARED ROTOR CONCEPT

"Free rotor" is the identification given to a concept whereby all accessory drives (engine or vehicle) are removed from the compressor turbine shaft. The baseline engine, which uses the "geared rotor" concept, was designed with engine auxiliaries (air pump, oil pump, regenerators, fuel pump/control) driven through gearing from the compressor turbine and the vehicle accessories (alternator, power steering pump, air conditioning compressor) driven from the power turbine. Schematics of baseline "geared rotor" and "free rotor" arrangements show the differences in basic designs. Potential advantages of a "free rotor" system are:

- Improved compressor rotor response
- Reduced overall engine noise
- Simplified gas generator design
- Improved cold starting
- Ability to use gas lubricated high-speed bearings
- Improved idle fuel economy
- More efficient usage of the power turbine stage at idle.

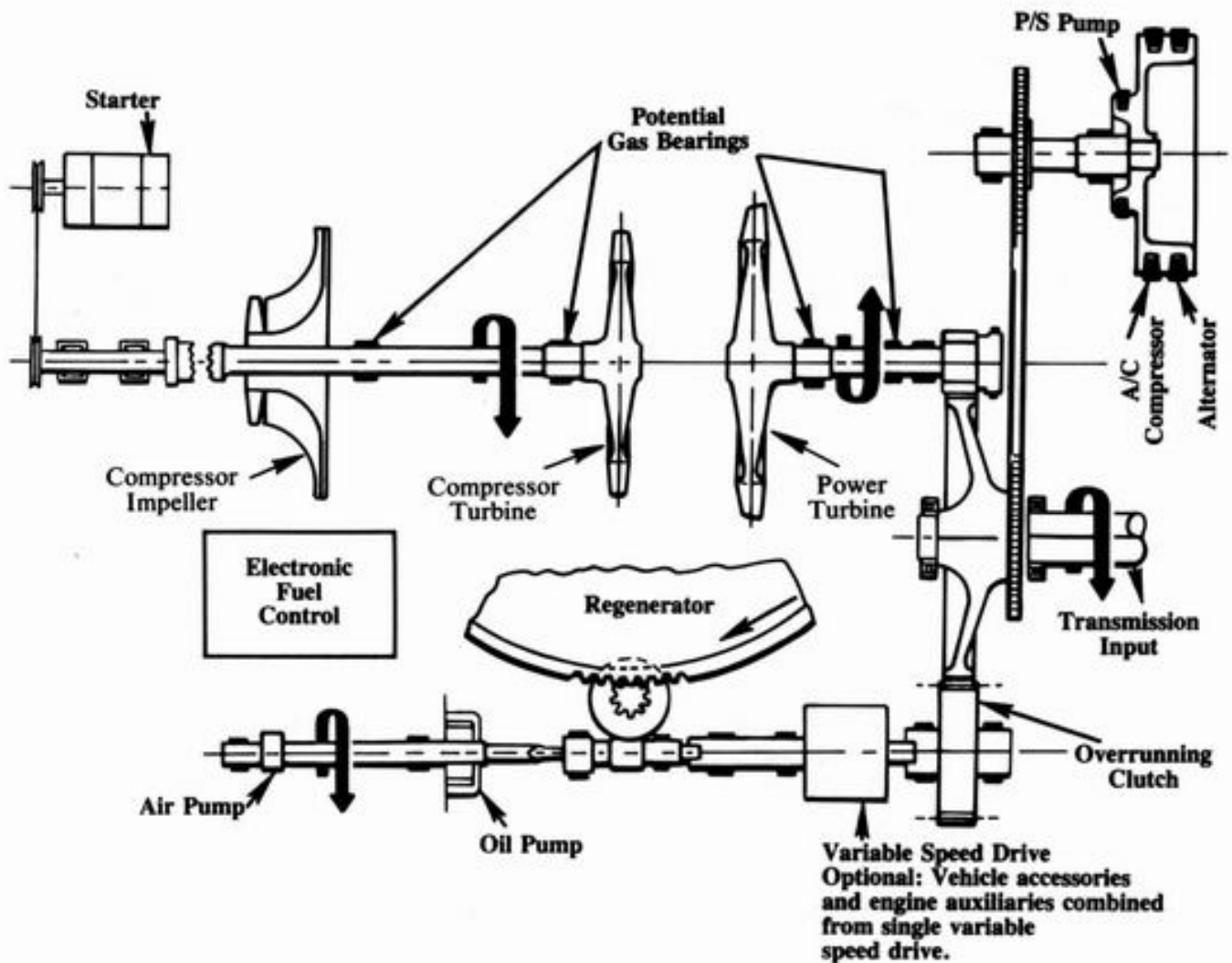

FREE ROTOR CONCEPT

The various improvements developed on the sixth generation engine were integrated into a new upgraded engine, called the seventh generation turbine. The seventh generation of Chrysler's gas turbine, which uses the free rotor concept, is a metal rotor technology engine, targeted to operate at about the same fuel economy as today's standard piston engines and to achieve the statutory emissions levels.

This engine development program was carried out from 1974 to 1978. In comparison with the sixth generation engine, the seventh generation engine is considerably smaller both because of its lower design horsepower, 104 versus 150 (78 - 112 kW), and its higher first stage turbine inlet temperatures, 1925° F (1052° C) versus 1850° F (1010° C). To achieve the required turbo-machinery efficiency levels in this smaller size, fundamental changes were necessary in the internal aerodynamics and design procedures. The National Aeronautical and Space Administration (NASA) is providing technical administration and support to DOE on this program.

A summary of the Chrysler/DOE turbine development program, baseline/upgraded engine comparison, and concept car/base car specifications are itemized in the following charts.

SUMMARY OF THE CHRYSLER/DOE GAS TURBINE DEVELOPMENT PROGRAM

Contract Participants: Chrysler Corporation, Division of Transportation Energy Conservation (TEC), Department of Energy (DOE), and the National Aeronautics and Space Administration (NASA)

Contract Awarded: November 22, 1972

Purpose of Contract: To develop a gas turbine powered automobile meeting the 1978 Federal NOx emissions standards and competitive in fuel economy, performance, reliability and potential manufacturing cost with a compact size American automobile powered by a conventional piston engine.

Steps in Development of Upgraded Turbine Engine:

1. Chrysler Corporation's sixth generation gas turbine engine has established the state-of-the-art and is serving as a baseline to verify component improvements.
2. Chrysler Corporation, DOE, NASA, and other government contractors have developed and evaluated improved components.
3. Chrysler Corporation has upgraded the baseline engine by incorporating improved components and technology into a new engine.
4. Chrysler Corporation is building, testing and installing upgraded engines in vehicles for final assessment and demonstration.

Engines and Vehicles to be Provided by Chrysler Corporation:

1. Seven baseline engines. Three of these engines are installed in 1973 model Plymouth and Dodge intermediate 4-door sedans. One of the engines was delivered to NASA for upgrading and development work. The remaining three engines are at Chrysler Corporation for upgrading and development work in test cells.
2. Seven upgraded engines. Four of these engines will be used in test cells for design verification and development. The remaining two will be installed in compact size production cars (modified 1976 Dodge Aspens) and one in a Turbine Concept Car.

Components and Concepts to be Evaluated and Developed:

Combustion systems; regenerator/seal systems; control systems; turbine wheels; transmission system; a free rotor; power augmentation; linerless insulation; and efficiency improvements.

ENGINE COMPARISON

Specifications	Baseline Engine (6th Generation)	Upgraded Engine (7th Generation)
Power	150 hp (112 kW)	104 hp (78 kW) Base 123 hp (92 kW) Augmented
Engine Weight	650 lb (295 kg)	500 lb (227 kg)
Vehicle Test Weight	4300 lb (1950 kg) (1973 Intermediate)	3500 lb (1588 kg) (1976 Compact)
0-60 mph Time	12 seconds	13 1/2 seconds
Turbine Inlet Temp.	1850° F (1010° C)	1925° F (1052° C)
Idle Fuel Flow	10 lb/h	(2.0 kg/h)

Configuration

Housing	3-piece	1-piece
Regenerator	2 Metal	1 Ceramic
Accessory Drive Engine (Regen., O/P) Vehicle (P/S, A/C, Alt.)	Gas Generator Power Turbine	Power Turbine (Free Rotor)
Control	Hydromechanical	Electronic
Transmission	3-speed Automatic	3-speed Automatic
Torque Converter	11 3/4 in. (298 mm) diameter	10 3/4 in. (273 mm) diameter - Lock-Up at 2-3 shift

CHRYSLER/DOE TURBINE CAR SPECIFICATIONS (7th Generation)

	Turbine Concept Car	1976 Dodge Aspen
Body Type	Restyled 1977 LeBaron 2-door	4-door Sedan
Wheelbase	112.7 in. (2863 mm)	112.5 in. (2858 mm)
Track	60.0 in. (1524 mm) front 58.5 in. (1486 mm) rear	
Overall Length	204.1 in. (5184 mm)	201.5 in. (5118 mm)
Overall Width	73.5 in. (1867 mm)	72.8 in. (1849 mm)
Overall Height	53.3 in. (1354 mm)	54.8 in. (1392 mm)
Engine	Upgraded Gas Turbine (7th Generation)	
Transmission	3-Speed Automatic	
Rear Axle Ratio	3.21	
Suspension	Transverse Torsion Bars	
Steering Type	Power	
Brakes	Hydraulic Power Assist	
Diameter		
Front	10.82 in. (275 mm) disc	
Rear	10 x 2.40 in. drum (254 x 61 mm)	
Tires, Radial	GR70 x 15 Glass Belt	FR78 x 14 Steel Belt
Weight	3884 lb (1762 kg)	3685 lb (1672 kg)

EMISSIONS AS A CRITICAL DESIGN PARAMETER

During the early development of the turbine, research scientists in California had related the smog in the air of certain U.S. cities to a complex photochemical reaction involving oxides of nitrogen (NOx) and hydrocarbons (HC). Both of these compounds are found in automotive exhaust. This led to enactment of stringent legislation which affected the exhaust, crankcase, and fuel systems of the automobile. This legislation created a situation in the automobile industry which required an all-out effort to solve.

These strict vehicle emissions standards actually enable the gas turbine to compete more favorably with the conventional piston engine. The only Federal Emission Standard that the Chrysler Corporation upgraded gas turbine does not fully meet is the oxides of nitrogen (NOx) limit; however, there are promising modifications which may reduce NOx emissions to the compliance level.



1976 — COMPACT SIZE — DODGE ASPEN



SMALLER—UPGRADED TURBINE ENGINE



DRAMATIC — AERODYNAMIC — TURBINE CONCEPT CAR



**UPGRADED TURBINE ENGINE
BUILT FOR THE U.S. DEPARTMENT OF ENERGY**

THE FUTURE

There are many economic, technological, and government regulatory factors which influence the turbine car's future. In the research laboratories, the turbine engine has met the original 1975 Federal exhaust emission standards and shows potential for meeting those of 1979 and beyond; but, in view of fuel economy regulations and a potential energy shortage, the turbine must demonstrate better fuel economy and driveability than a piston engine while meeting these standards. Other items to be resolved are the turbine engine's dependence on high cost nickel alloys and the economics of tooling a new engine plant and the training of personnel prior to production of a turbine engine. These must be weighed against the conventional engine's increasing need for unleaded fuel and its reliance on imported rare materials for the necessary catalysts.

A promising future design concept is to use ceramics in place of nickel alloys in the hot sections, and to replace the typical turbine of two shafts, two sets of variable blading and a three-speed transmission with a single-shaft turbine with a single compressor impeller and single radial turbine coupled to a continuously-variable transmission. The use of ceramics would allow up to 2500° F (1400° C) operating temperatures where a 20 percent fuel economy improvement potential could be realized. This increase in temperature permitted by the use of ceramics would contribute to a decrease in engine size and weight. Both silicon carbide and silicon nitride ceramic materials have shown promising developments recently for such turbine engine applications.

Another key component under development for the upgraded engine is an integrated electronic system which controls engine operation by controlling the fuel system, the power turbine nozzle vane position, the position of the compressor inlet guide vanes, the water injection system, and the engine starting sequence. The control system will also include a diagnostic feature for ease of maintenance and evaluation.

As automobiles become increasingly more expensive to buy and maintain, car buyers will expect them to last longer with less maintenance. The turbine, with fewer parts, requires no routine maintenance other than cleaning the air filter occasionally and replacing the single spark plug about every 25,000 miles (40 000 km). It has been run in tests equivalent of 175,000 miles (280 000 km) without a major repair. Perhaps, after further development, this operating economy could help overcome the inherent material cost disadvantage of the gas turbine engine and enable it to compete for certain vehicle applications on a functional and economic basis.