

---

This is a reproduction of a library book that was digitized by Google as part of an ongoing effort to preserve the information in books and make it universally accessible.

Google™ books

<https://books.google.com>







600046982Z

399 d.  $\frac{1868}{18}$







THE  
LONDON ENCYCLOPÆDIA.

VOL. XVIII.

POTASH TO ROME.



THE  
**LONDON ENCYCLOPÆDIA,**

OR

**UNIVERSAL DICTIONARY**

OF

**SCIENCE, ART, LITERATURE, AND PRACTICAL MECHANICS,**

COMPRISING A

**POPULAR VIEW OF THE PRESENT STATE OF KNOWLEDGE.**

ILLUSTRATED BY

**NUMEROUS ENGRAVINGS, A GENERAL ATLAS,  
AND APPROPRIATE DIAGRAMS.**

---

*Sic oportet ad librum, presertim miscellanæ generis, legendum accedere lectorem, ut solet ad convivium conviva civilis. Convivator annittitur omnibus satisfacere; et tamen si quid apponitur, quod hujus aut illius palato non respondeat, et hic et ille arbane dissimulant, et alia fercula probant, ne quid contristent convivatorem.* *Erasmus.*

A reader should sit down to a book, especially of the miscellaneous kind, as a well-behaved visitor does to a banquet. The master of the feast exerts himself to satisfy his guests; but if, after all his care and pains, something should appear on the table that does not suit this or that person's taste, they politely pass it over without notice, and commend other dishes, that they may not distress a kind host. *Translation.*

---

**BY THE ORIGINAL EDITOR OF THE ENCYCLOPÆDIA METROPOLITANA,**

ASSISTED BY EMINENT PROFESSIONAL AND OTHER GENTLEMEN.

IN TWENTY-TWO VOLUMES.

**VOL. XVIII.**

---

**LONDON :**

**PRINTED FOR THOMAS TEGG, 73, CHEAPSIDE;**

**R. GRIFFIN & Co., GLASGOW; TEGG AND CO., DUBLIN; ALSO J. & S. A. TEGG,  
SYDNEY AND HOBART TOWN.**

**1839.**





LONDON :

PRINTED BY J. HADDON, CASTLE STREET, FINSBURY.

THE  
LONDON ENCYCLOPÆDIA.

**POT, n. s.**  
**POTABLE, adj.**  
**POTATION, n. s.**  
**POTHERB,**  
**POT-HOOK,**  
**POT-LID,**  
**POT-SHERD,**  
**POTTAGE,**  
**POTTER.**

Fr. and Belg. *pot*, in all the senses; Islandic and Dan. *potte*; Goth. *pott*. A vessel in which meat is boiled; any vessel to hold liquids; a cup: 'to go to pot,' to be destroyed or devoured: to pot is to preserve in pots: potable is drinkable: potation, a draught: potherb is a herb fit for boiling: pot-hook and pot-lid explain themselves: potsherd (pot and sherd, from Belg. *schaerde*; properly potshard), a fragment of a broken pot: pottage, any thing boiled for food. Jacob sod *pottage*, and Esau came from the *fi. e. a.* faint. *Genesis.*

The woman left her water-pot, and went her way. *John.*

He on the ashes sits, his fate deploras;  
 And with a *potsherd* scrapes the swelling sores. *Sandys.*

Toad that under the cold stone  
 Sweltered, venom sleeping got;  
 Boil thou first i' th' charmed *pot*. *Shakspeare.*  
 But that I think his father loves him not,  
 I'd have him poisoned with a *pot* of ale. *Id.*  
 My thoughts are whirled like a *potter's* wheel. *Id.*

I learnt it in England, where they are most potent  
 in *potting*. *Id. Othello.*

Thou best of gold art worst of gold,  
 Other less fine in carat is more precious,  
 Preserving life in medicine *potable*. *Shakspeare.*  
 If I had a thousand sons, the first human principle  
 I would teach them, should be to forswear thin  
*vestations*, and to addict themselves to sack. *Id. Henry IV.*

At this day at Gaza, they couch *potsherd*s of ves-  
 sels of earth in their walls to gather the wind from  
 the top, and pass it in spouts into rooms. *Bacon's Natural History.*

Dig a pit upon the sea shore, somewhat above the  
 high-water mark; and sink it as deep as the low-  
 water mark; and, as the tide cometh in, it will fill  
 with water fresh and *potable*. *Bacon.*

The said *potable* gold should be endued with a ca-  
 pacity of being agglutinated and assimilated to the  
 innate heat. *Harvey.*

Rivers run *potable* gold. *Milton's Paradise Lost.*

Gigantic minds, as soon as work was done,  
 To their huge *pots* of boiling pulse would run,  
 Fell to with eager joy. *Dryden.*

*Potted* fowl and fish come in so fast,  
 That ere the first is out the second stinks,  
 And mouldy mother gathers on the brinks. *Id.*  
 Whence come broken *potsherd*s tumbling down,  
 And leaky ware from garret windows thrown:  
 Well may they break our heads. *Id.*  
 Some press the plants with *sherd*s of *potter's* clay. *Id.*

Egypt baser than the beasts they worship;  
 Below their *potherb* gods that grow in gardens. *Id.*

Let me see her Arabian *pot-hooks*. *Id.*  
 The sheep went first to *pot*, the goats next, and  
 after them the oxen, and all little enough to keep  
 life together. *L'Estrange.*  
 Whenever *potters* meet with any chalk or marl  
 mixed with their clay, though it will with the clay  
 hold burning, yet, whenever any water comes near  
 any such *pots* after they are burnt, both the chalk  
 and marl will slack and spoil their ware. *Mortimer.*

Acorns, mast, and other seeds may be kept well,  
 by being barrell'd or *potted* up with moist sand. *Id.*

A *potter* will not have any chalk or marl mixed  
 with the clay. *Id. Husbandry.*  
*Pot* them in natural, not forced earth; a layer of  
 rice mould beneath and about this natural earth to  
 nourish the fibres, but not so as to touch the bulbs. *Evelyn.*

Where solar beams  
 Parch thirsty human veins, the damask'd meads  
 Unforced display ten thousand painted flowers  
 Useful in *potables*. *Philips.*  
 Sir Tristram telling us tobacco was a *potherb*, bid  
 the drawer bring in 'other half pint. *Taitler.*  
 Suppose your eyes sent equal rays  
 Upon two distant *pots* of ale,  
 Not knowing which was mild or stale. *Prior.*  
 He like the *potter* in a mould has cast  
 The world's great fame. *Id.*  
 John's ready money went into the lawyers' pockets;  
 then John began to borrow money upon the bank  
 stock, now and then a farm went to *pot*. *Arbuthnot's History of John Bull.*

Of alimentary leaves, the olera or *potherbs* afford  
 an excellent nourishment; amongst those are the  
 cole or cabbage kind. *Arbuthnot.*  
 The columella is a fine, thin, light, bony tube, the  
 bottom of which spreads about, and gives it the re-  
 semblance of a wooden *potlid* in country houses. *Derham.*

A soldier drinks his *pot*, and then offers payment. *Swift.*  
 Leaves eaten raw are termed sallad; if boiled,  
 they become *potherbs*: and some of those plants  
 which are *pot-herbs* in one family, are sallads in an-  
 other. *Watts.*  
 For great the man, and useful, without doubt,  
 Who seasons *pottage*, or expels the gout;  
 Whose science keeps life in, and keeps death out. *Harte.*

**POTAGER, n. s.** From Pottage. A por-  
 ringer.  
 An Indian dish or *potager*, made of the bark of  
 a tree, with the sides and rim sewed together after  
 the manner of twigen-work. *Grew's Museum.*

**POTAMOGETON,** pond weed, a genus of  
 the tetragynia order, and tetrandria class of plants;  
 natural order fifteenth, inundatæ: CAL. none;  
 petals four; no style, and four seeds. There  
 are twelve species, all of them vegetables floating  
 on the surface of stagnant waters, affording  
 agreeable shade to fish, and food to cattle.

POTAMON, or ΠΟΤΑΜΟ, a philosopher of Alexandria. He attached himself to none of the schools of philosophy of his time; but kept a middle course between the scepticism of the Pyrrhonians and the presumption of the dogmatists. He was the first projector of the Eclectic sect; for, though their mode of philosophising had been common before, he was the first that attempted to institute a new sect on this principle. 'Diogenes Laertius relates that, not long before he wrote his Lives of the Philosophers, an Eclectic sect, *ελεκτικα τας αιρεσις*, had been introduced by Potamo of Alexandria, who selected tenets from every former sect. Suidas and Porphyry also mention him. The time when Potamo flourished is uncertain. Suidas places him under Augustus; but it is more probable, from the account of Laertius, that he flourished about the close of the second century.'

POTAR'GO, *n. s. Ital. potarge.* A West Indian pickle.

What lord of old would bid his cook prepare Mangos, *potargo*, champignons, cavarre? *King.*

POTASIL, *n. s. Fr. potasse.* The vegetable alkali. See below.

Cheshire rock-salt, with a little nitre, allum, and *potash*, is the flux used for the running of the plate-glass. *Woodward.*

POTASH, or POTASSA, in chemistry and the manufactures, more commonly known as the vegetable alkali, is a fixed alkaline salt obtained from the ashes of burnt vegetables of various kinds. The method of making potash is described by Dr. Shaw as follows:—Burn a quantity of billet wood to gray ashes; and, taking several pounds of these ashes, boil them in water, so as to make a very strong lixivium or lie. Let this lie be strained through a coarse linen cloth, to keep out any parts of half-burnt wood that might happen to remain in the ashes; then evaporate this strained lie in an iron pan, over a quick fire, almost to dryness: then, taking out the matter remaining at the bottom, and putting it into an iron crucible, set it in a strong fire till the matter is melted, and then immediately pour it out upon an iron plate, where it soon cools, and appears in the form of a solid lump of potash. In this manner potash is made in the large way of business, for the service of the soap-boiler, glass-maker, fuller, &c.; but, according to the difference of the wood, or combustible matter employed, with the manner of turning it, and conducting the process, different kinds of potash are prepared. There are certain saline plants that yield this potash to great advantage, as particularly the plant kali; there are others that afford it in less plenty, and of an inferior quality, as bean-stalks, &c.; but, in general, all vegetable subjects afford it of one kind or other, and may most of them be made to yield it tolerably perfect after the manner of the process already laid down, even the loppings, roots, and refuse parts of ordinary trees, vine-clippings, &c.

It was announced in the philosophical Journals that, in France, potash had been obtained in great quantities from potato stalks. In order to put this to the test of experiment, Sir John Hay and Dr. McCulloch made a trial on a large scale, and found that the quantity of potash was

so small that no person could be remunerated by it for the trouble of the process. Messrs. Taylors of Queensferry, by desire of Sir John Hay, made an experiment on the produce of two acres of potato stalks, which yielded two casks of ashes, weighing 2 cwt. 23 lbs., which produced of soluble substance only 36 lbs., containing a great deal of muriate of potash and sulphate of potash. The value of this produce was not more than 2*d.* per lb., or 6*s.* in all; and on twelve acres of their own they had a similar result.

The following is a table of the saline product of 1000 lbs. of ashes of the following vegetables:—

	Saline products.
Stalks of Turkey wheat, } or maize, }	198 lbs.
Stalks of sunflower .	349
Vine branches .	162·6
Elm . . . . .	166
Box . . . . .	78
Sallow . . . . .	102
Oak . . . . .	111
Aspen . . . . .	61
Beech . . . . .	219
Fir . . . . .	132
Fern cut in August	116 } or 125 according to Wildenheim.
Wormwood . . . . .	748
Fumitory . . . . .	360
Heath . . . . .	115 Wildenheim.

On these tables Kirwan makes the following remarks:—1. That in general weeds yield more ashes, and their ashes much more salt, than woods; and that consequently, as to salts of the vegetable alkali kind, as potash, pearl-ash, cashup, &c., neither America, Trieste, nor the northern countries, have any advantage over Ireland. 2. That of all weeds fumitory produces most salt, and next to it wormwood. But, if we attend only to the quantity of salt in a given weight of ashes, the ashes of wormwood contain most. Trifolium fibrinum also produces more ashes and salt than fern. Dr. John of Berlin observes that uncombined potash does not occur in living vegetables, it being always combined with an acid, and is only found in them when they are in a state of putridity or decomposition. Plants that feel rough and sharp, particularly equiseti, contain much siliceous earth; in the latter full thirteen per cent. Lichens that grow on the summits of fir trees contain an uncommon proportion of oxide of iron, which, Dr. John remarks, may be viewed as illustrative of the formation of iron by the vegetable process. Dr. John recommends the use of decaying and diseased wood to those who wish to obtain potash from it by burning, as he maintains that the quantity of potash is much increased by the putrefactive process. This remark is not new; for we find it mentioned in the second volume of Schreber's *Sammlung verschiedener Schriften*, published in 1763, that putrid wood was recommended for obtaining ashes in preference to fresh wood. Plants, which were allowed to grow in a solution of natron, absorbed by their roots a considerable portion of the alkali; but none of this appeared when the ashes of the plant were examined: in

place of it appeared potash; and hence it is conjectured that vegetables have the power of converting natron into potash.

The process for obtaining pot and pearl-ash is given by Kirwan as follows:—

1. The weeds should be cut just before they seed, then spread, well dried, and gathered clean.

2. They should be burned within doors on a grate, and the ashes laid in a chest as fast as they are produced. If any charcoal be visible, it should be picked out, and thrown back into the fire. If the weeds be moist, much coal will be found. A close smothered fire, which has been recommended by some, is very prejudicial.

3. They should be lixiviated with twelve times their weight of boiling water. A drop of the solution of corrosive sublimate will immediately discover when the water ceases to take up any more alkali. The earthy matter that remains is said to be a good manure for clayey soils.

4. The lie thus formed should be evaporated to dryness in iron pans. Two or three at least of these should be used, and the lie, as fast as it is concreted, passed from the one to the other. Thus, much time is saved, as weak lies evaporate more quickly than the stronger. The salt thus produced is of a dark color, and contains much extractive matter; and, being formed in iron pots, is called potash.

5. This salt should then be carried to a reverberatory furnace, in which the extractive matter is burnt off, and much of the water dissipated: hence it generally loses from ten to fifteen per cent. of its weight. Particular care should be taken to prevent its melting, as the extractive matter would not then be perfectly consumed, and the alkali would form such a union with the earthy parts as could not easily be dissolved. Kirwan adds this caution, because Dr. Lewis and Mr. Dossie have inadvertently directed the contrary. This salt, thus refined, is called pearl-ash, and must be the same as the Dantzic pearl-ash.

To obtain this alkali pure, Berthollet recommends to evaporate a solution of potash, made caustic by boiling with quicklime, till it becomes of a thickish consistence; to add about an equal weight of alcohol, and let the mixture stand some time in a close vessel. Some solid matter, partly crystallised, will collect at the bottom; above this will be a small quantity of a dark-colored fluid; and on the top another lighter. The latter, separated by decantation, is to be evaporated quickly in a silver basin in a sand-heat. Glass, or almost any other metal, would be corroded by the potash. Before the evaporation has been carried far, the solution is to be removed from the fire, and suffered to stand at rest; when it will again separate into two fluids. The lighter, being poured off, is again to be evaporated with a quick heat; and, on standing a day or two in a close vessel, it will deposit transparent crystals of pure potash. If the liquor be evaporated to a pellicle, the potash will concrete without regular crystallisation. In both cases a high-colored liquor is separated, which is to be poured off; and the potash must be kept carefully secluded from air.

Its taste is remarkably acrid, and it is so exceedingly corrosive that, when applied to any

part of the body, it destroys it almost instantaneously. On account of this property it has been called caustic, and is often used by surgeons to open abscesses, and destroy useless or hurtful excrements. When heated it melts. At a red heat it swells, and evaporates slowly in a white acrid smoke. When exposed to the air it soon attracts moisture, and is converted into a liquid; and combines with carbonic acid, for which it has a great affinity. It has a very strong affinity for water. At the common temperature of the air, one part of water dissolves two parts of potassa. The solution is transparent, very dense, and almost of the consistence of oil. In this state it is usually employed by chemists. When four parts of potash in powder, and one of snow are mixed together, the mixture becomes liquid, and absorbs a quantity of caloric. This mixture was employed by Lowitz to produce artificial cold. When the aqueous solution of potash is evaporated to a proper consistency, the potash crystallises. The shape of its crystals is very different, according to the way in which they have been produced. When allowed to form in the cold, they are octahedrons in groups, and contain 0.43 of water: when formed by evaporation on the fire, they assume the figure of very thin transparent blades of extraordinary magnitude, which, by an assemblage of lines crossing each other in prodigious numbers, present an aggregate of cells or cavities, commonly so very close that the vessel may be inverted without losing one drop of the liquid it contains. Potash is not altered by exposure to the light.

A perfectly pure solution of potash will remain transparent on the addition of lime-water, show no effervescence with dilute sulphuric acid, and not give any precipitate on blowing air from the lungs through it by means of a tube.

Pure potash for experimental purposes may most easily be obtained by igniting cream of tartar in a crucible, dissolving the residue in water, filtering, boiling with a quantity of quicklime, and, after subsidence, decanting the clear liquid, and evaporating in a loosely covered silver capsule, till it flows like oil, and then pouring it out on a clean iron plate. A solid white cake of pure hydrate of potash is thus obtained, without the agency of alcohol. It must be immediately broken into fragments, and kept in a well-stoppered phial.

As 100 parts of subcarbonate of potash are equivalent to about seventy of pure concentrated oil of vitriol, if into a measure tube, graduated into 100 equal parts, we introduce the seventy grains of acid, and fill up the remaining space with water, then we have an alkalimeter for estimating the value of commercial pearl-ashes, which, if pure, will require for 100 grains 100 divisions of the liquid to neutralise them. If they contain only sixty per cent. of genuine subcarbonate, then 100 grains will require only sixty divisions, and so on. When the alkalimeter indications are required in pure or absolute potash, such as constitutes the basis of *niue*, then we must use 102 grains of pure oil of vitriol, along with the requisite bulk of water to fill up the volume of the graduated tube.

The hydrate of potash, as obtained by the preceding process, is solid, white, and extremely caustic; in minute quantities, changing the purple of violets and cabbage to a green, reddened litmus to purple, and yellow turmeric to a reddish-brown. It rapidly attracts humidity from the air, passing into the oil of tartar per deliquium of the chemists; a name, however, also given to the deliquesced subcarbonate. Charcoal applied to the hydrate of potash at a cherry-red heat gives birth to carburetted hydrogen, and an alkaline subcarbonate; but, at a heat bordering on whiteness, carburetted hydrogen, carbonous oxide, and potassium are formed. Several metals decompose the hydrate of potash, by the aid of heat; particularly potassium, sodium, and iron. The fused hydrate of potash consists of 6 protoxide of potassium + 1.125 water = 7.125, which number represents the compound prime equivalent. It is used in surgery as the potential cautery for forming eschars; and it was formerly employed in medicine diluted with broths as a lithontriptic. In chemistry it is very extensively employed, both in manufactures and as a reagent in analyses. It is the basis of all the common soft soaps.

Dr. Wollaston has recently ascertained the existence of potash in sea-water. He estimates the proportion of this alkali, which he supposes to exist in the state of sulphate, at something less than  $\frac{1}{550}$ th part of the water, at its average density. He has also detected traces of potash in the water of the lake of Ourmia or Arumea, which is unconnected with the ocean. The water of this lake (which is situated on the province of Azerbaijan in Persia) is said to be saltier than that of the sea, so that no fish can live in it.

Potash, until Sir Humphry Davy's memorable discovery of its chemical nature, was considered as a simple body, though strong suspicions were entertained of its being of a compound nature. From that philosopher's researches, however, potash appears to consist of a metallic basis, which he called potassium, united with oxygen, in the following proportions:—

Potassium . . .	83
Oxygen . . .	17
	100

POTASSIUM, in chemistry, the name given by Sir H. Davy to the metallic base of potash, discovered by him in 1807. Till this period potash and soda were necessarily regarded as simple from the impossibility of decomposing them by any known methods. Yet they were generally suspected to be compounds, though no chemist was able to detect their elements. By many the alkaline principle was supposed to be nitrogen, as the acidifiable was oxygen. Morveau and Desormes published an ingenious set of experiments, in which they endeavoured to prove that potash was a compound of hydrogen and lime. Darracq, however, with that accuracy which has characterised most of his enquiries, soon disproved this theory, and evinced that the results obtained by Desormes and Morveau were owing, in most cases, to the impurity of the

potash with which they had made their experiments; while in others they had drawn wrong inferences from mistaken resemblances.

As soon as voltaic electricity was so far rendered manageable as to be applied with very great power to chemical analyses, Mr. Davy conceived the idea of enlisting this wonderful agency into his service, with a view of endeavouring to obtain a decomposition of the alkalies; and he was the more fully induced to give a full scope and latitude to a series of experiments of this kind from observing that if a neutral substance, or a compound of an acid and an alkali, constituted a part of the voltaic circle, a decomposition of such substance was the result, the acid alone always travelling to the positive side of the chain and the alkali to the negative.

In the first attempts which Sir H. Davy made for the decomposition of the fixed alkalies, he entirely failed, in consequence of his having acted upon their aqueous solutions only. He afterwards used potash in the state of igneous fusion, and acted upon it by an electrical power, which was produced from a galvanic battery of 100 plates of six inches square, highly charged. Here some brilliant phenomena were produced. A most intense light and a column of flame were exhibited, which seemed to be owing to the development of combustible matter; and when the order was changed, so that the alkali was brought in contact with the negative side of the battery, æriform globules, which inflamed in the atmosphere, rose through the potash. Being, however, unable to collect the products of decomposition by this means, he had then recourse to pure potash in its usual state, and depended on electricity alone for its fusion, as well as its decomposition.

A small piece of pure potash, moistened a little by the breath, was placed upon an insulated disc of platinum, connected with the negative side of a battery consisting of 100 plates of six inches and 150 of four inches square, in a state of intense activity, and a platinum wire, communicating with the positive side, was brought in contact with the upper surface of the alkali. Under these circumstances, a vivid action soon commenced. The potash began to fuse at both its points of electrification, and small globules, having a high metallic lustre and precisely similar in visible characters to quicksilver, appeared, some of which burnt with explosion and bright flame. These globules, which appeared to be metallic, were the basis of potash.

If iron turnings be heated to whiteness in a curved gun-barrel, and potash be melted and made slowly to come in contact with the turnings, air being excluded, potassium will be formed, and will collect in the cool part of the tube. This method of procuring it was discovered by M. M. Gay Lussac and Thénard in 1808. It may likewise be produced by igniting potash with charcoal, as M. Curaudau showed the same year.

M. Brunner, by acting on calcined tartar in a bottle of wrought iron, has succeeded in obtaining potassium at a comparatively moderate heat. The bottle is spheroidal, about half an inch in thickness, and capable of holding about a pint

of water; a bent gun-barrel of ten or twelve inches in length screws into the mouth of the bottle. The bottle, well luted over with fire-clay, is set in a strong air furnace, so that the tube may dip down externally beneath the surface of naphtha contained in a cylindrical copper vessel, standing in a tub containing ice and water. The top of the naphtha vessel has a cover fixed on it, pierced with a hole to receive the end of the gun-barrel; and, from the side of the upper part of the vessel, a small tube goes off at right angles to let the air and vapors escape. It is advantageous to mix a little ground charcoal with the tartar previously calcined in a covered vessel, in the same iron bottle for example. Nearly 300 grains of potassium have been procured by this apparatus from twenty-four ounces of crude tartar.—*Bibliothèque Universelle*, xxii. 36.

Potassium is possessed of very extraordinary properties. It is lighter than water, its specific gravity being 0.865 to water 1.0. At common temperatures it is solid, soft, and easily moulded by the fingers. At 150° Fahrenheit it fuses, and in a heat a little below redness it rises in vapor. It is perfectly opaque. When newly cut, its color is splendid white, like that of silver, but it rapidly tarnishes in the air. To preserve it unchanged, we must enclose it in a small phial, with pure naphtha. It conducts electricity like the common metals. When thrown upon water, it acts with great violence, and swims upon the surface, burning with a beautiful light of a red color, mixed with violet. The water becomes a solution of pure potash. When moderately heated in the air, it inflames, burns with a red light, and throws off alkaline fumes. Placed in chlorine, it spontaneously burns with great brilliancy.

On all fluid bodies which contain water, or much oxygen or chlorine, it readily acts; and in its general powers of chemical combination, says its illustrious discoverer, potassium may be compared to the alkahest, or universal solvent, imagined by the alchemists.

Potassium combines with oxygen in different proportions. When potassium is gently heated in common air, or in oxygen, the result of its combustion is an orange-colored fusible substance. For every grain of the metal consumed, about one cubic inch and seven-tenths of oxygen are condensed. To make the experiment accurately, the metal should be burned in a tray of platina covered with a coating of fused muriate of potash.

The substance procured by the combustion of potassium at a low temperature, was first observed in October 1807, by Sir Humphry Davy, who supposed it to be the protoxide; but M. M. Gay Lussac and Thenard, in 1810, showed that it was in reality the deutoxide, or peroxide. When it is thrown into the water, oxygen is evolved, and a solution of the protoxide results, constituting common aqueous potash. When it is fused, and brought in contact with combustible bodies, they burn vividly, by the excess of its oxygen. If it be heated in carbonic acid, oxygen is disengaged, and common subcarbonate of potash is formed.

When it is heated very strongly upon platina,

oxygen gas is expelled from it, and there remains a difficultly fusible substance of a gray color, vitreous fracture, soluble in water without effervescence, but with much heat. Aqueous potash is produced. The above ignited solid is protoxide of potassium, which becomes pure potash by combination with the equivalent quantity of water. When we produce potassium with ignited iron-turnings and potash, much hydrogen is disengaged from the water of the hydrate, while the iron becomes oxidised from the residuary oxygen. By heating together pure hydrate of potash and boracic acid, Sir H. Davy obtained from seventeen to eighteen of water from 100 parts of the solid alkali.

By acting on potassium with a very small quantity of water, or by heating potassium with fused potash, the protoxide may also be obtained. The proportion of oxygen in the protoxide is determined by the action of potassium upon water. Eight grains of potassium produce from water about nine cubic inches and a half of hydrogen; and for these the metal must have fixed four cubic inches and three quarters of oxygen. But as 100 cubic inches of oxygen weigh 33.9 gr. 4½ will weigh 1.61. Thus, 9.61 gr. of the protoxide will contain eight of metal; and 100 will contain 83.25 metal + 16.75 oxygen. From these data, the prime of potassium comes out 4.969; and that of the protoxide 5.969. Sir H. Davy adopts the number 75 for potassium, corresponding to 50 on the oxygen scale.

When potassium is heated strongly in a small quantity of common air, the oxygen of which is not sufficient for its conversion into potash, a substance is formed of a grayish color, which, when thrown into water, effervesces without taking fire. It is doubtful whether it be a mixture of the protoxide and potassium, or a combination of potassium with a smaller proportion of oxygen than exists in the protoxide. In this case it would be a suboxide, consisting of 2 primes of potassium = 10 + 1 of oxygen = 11.

When thin pieces of potassium are introduced into chlorine, the inflammation is very vivid; and, when potassium is made to act on chloride of sulphur, there is an explosion. The attraction of chlorine for potassium is much stronger than the attraction of oxygen for the metal. Both of the oxides of potassium are immediately decomposed by chlorine, with the formation of a fixed chloride, and the extrication of oxygen.

The combination of potassium and chlorine is the substance which has been improperly called muriate of potash, and which in common cases, is formed by causing liquid muriatic acid to saturate solution of potash, and then evaporating the liquid to dryness and igniting the solid residuum. The hydrogen of the acid here unites to the oxygen of the alkali, forming water, which is exhaled; while the remaining chlorine and potassium combine. It consists of 5 potassium + 4.5 chlorine.

Potassium combines with hydrogen, to form potassureted hydrogen, a spontaneously inflammable gas, which comes over occasionally in the production of potassium by the gun-barrel experiment. MM. Gay Lussac and Thenard describe

also a solid compound of the same two ingredients, which they call a hyduret of potassium. It is formed by heating the metal a long while in the gas, at a temperature just under ignition. They describe it as a grayish solid, giving out its hydrogen on contact with mercury.

When potassium and sulphur are heated together, they combine with great energy, with disengagement of heat and light even in vacuo. The resulting sulphuret of potassium is of a dark gray color. It acts with great energy on water, producing sulphureted hydrogen, and burns brilliantly when heated in the air, becoming sulphate of potash. It consists of 2 sulphur + 5 potassium, by Sir H. Davy's experiments. Potassium has so strong an attraction for sulphur that it rapidly separates it from hydrogen. If the potassium be heated in the sulphureted gas, it takes fire and burns with great brilliancy; sulphuret of potassium is formed, and pure hydrogen is set free.

Potassium and phosphorus enter into union with the evolution of light; but the mutual action is feebler than in the preceding compound. The phosphuret of potassium, in its common form, is a substance of a dark chocolate color, but when heated with potassium in great excess it becomes of a deep gray color, with considerable lustre. Hence it is probable that phosphorus and potassium are capable of combining in two proportions. The phosphuret of potassium burns with great brilliancy when exposed to air, and when thrown into water produces an explosion, in consequence of the immediate disengagement of phosphureted hydrogen.

Charcoal which has been strongly heated in contact with potassium effervesces in water, rendering it alkaline, though the charcoal may be previously exposed to a temperature at which potassium is volatilised. Hence there is probably a compound of the two formed by a feeble attraction.

Of all known substances, potassium is that which has the strongest attraction for oxygen; and it produces such a condensation of it, that the oxides of potassium are denser than the metal itself. Potassium has been skilfully used by Sir H. Davy and M.M. Gay Lussac and Thénard, for detecting the presence of oxygen in bodies. A number of substances, undecomposable by other chemical agents, are readily decomposed by this substance.

When a globule is placed upon ice, not even the solid form of both the substances can prevent their union; for the metalloïd instantly burns with a bright flame, and a deep hole is made in the ice, which is found to contain a solution of potash. When a globule is dropped upon moistened turmeric paper, it instantly burns, and moves rapidly upon the paper, as if in search of moisture, leaving behind it a deep reddish brown trace. So strong is the attraction of the basis of potash for oxygen, that it discovers and decomposes the small quantities of water contained in alcohol and ether, even when they are carefully purified.

POTATO, *n. s.* An American word, *battata* originally. See below. An esculent root.

On choicest melons and sweet grapes they dine,  
And with potatoes fat their wanton swine. *Waller.*

Leek to the Welch, to Dutchmen butter's dear,  
Of Irish swains potatoe is the chear;  
Oats for their feasts the Scottish shepherds grind,  
Sweet turnips are the food of Blouzalind;  
While she loves turnips butter I'll despise,  
Nor leeks, nor oatmeal, nor potatoe prize. *Gay.*

The families of farmers live in filth and nastiness upon buttermilk and potatoes. *Swift.*

The red and white potatoes are the most common esculent roots now in use, and were originally brought from Virginia into Europe. *Miller.*

POTATO, in botany. See SOLAKUM. Potatoes came originally from North America, where they were not reckoned good for food. They were first introduced into Ireland in 1565, and thence into England by a vessel wrecked on the western coast, at North Meols, in Lancashire, a place and soil still famous for producing this vegetable in great perfection. It was forty years after their introduction, however, before they were much cultivated about London; and then they were considered as rarities, without any conception of the utility that might arise from bringing them into common use. At this time they were distinguished from the Spanish by the name of Virginia potatoes, or *battatas*, which is the Indian name of the Spanish sort. At a meeting of the Royal Society, March 18th, 1662-3, a letter was read from Mr. Buckland, a Somerset gentleman, recommending the planting of potatoes in all parts of the kingdom to prevent famine. This was referred to a committee; and, in consequence of their report, Mr. Buckland had the thanks of the society; such members as had lands were entreated to plant them, and Mr. Evelyn was desired to mention the proposals at the close of his *Sylva*. In Sweden, notwithstanding the indefatigable industry of Linnæus, the culture of potatoes was only introduced in 1764, when a royal edict was published to encourage their general cultivation. They were known there, however, at an earlier period; for, in the Memoirs of the Royal Academy of Sciences in Sweden, 1747, M. Charles Skytse proposed to distil brandy from them, in order to save corn, which in that country is very dear. He found that an acre of land set with potatoes will yield a much greater quantity of brandy than when sown with barley. The utility of potatoes is well known, and this utility has brought them into general use, and has extended them over every part of this kingdom. To promote this utility, and to make their cultivation more easy, a variety of experiments and inquiries have been made. See RURAL ECONOMY.

POTATO. The following account of the potato was communicated to the Board of Agriculture by Dr. Wright of Edinburgh.

The potato is a native of America, and was well known to the Indians long before the conquest of Mexico and Peru. Gomara, in his General History of the Indies, and Josephus Acosta, are amongst the earliest Spanish writers who have mentioned the potato by the Indian names of *openanck*, *pape*, and *papas*. Clusius, and after him Gerard, gave figures of the potato plant. Gerard was the first author who gave it the

name of *solanum tuberosum*, which Linnæus and his followers have adopted. In 1584, Sir Walter Raleigh, so celebrated for his worth, his valour, and his misfortunes, discovered that part of America called Norembega, and by him named Virginia; whether the admiral was acquainted with the potato in his first voyage, or whether it was sent to him by Sir Thomas Grenville, or by Mr. Lane, the first governors of Virginia, is uncertain. It is probable he was possessed of this root about the year 1586. He is said to have given it to his gardener in Ireland, as a fine fruit from America, and which he desired him to plant in his kitchen garden in the spring. In August this plant flowered, and in September produced a fruit; but so different to the gardener's expectation, that, in an ill-humour, he carried the potato apple to his master. "Is this," said he, "the fine fruit from America you prized so highly?" Sir Walter either was, or pretended to be, ignorant of the matter; and told the gardener, since that was the case, to dig up the weed and throw it away. The gardener soon returned with a good parcel of potatoes. Gerard, an old English botanist, received seedlings of the potato about the year 1590; and tells us, that it grew as kindly in his garden as in its native soil, Virginia. The plant was cultivated in the gardens of the nobility and gentry early, about the year 1620, as a curious exotic; and towards the year 1684, was planted out in the fields, in small patches, in Lancashire. From thence it was gradually propagated all over the kingdom, as well as in France. In 1683, Sutherland has inserted the *solanum tuberosum* in his *Hortus Medicus Edinburgensis*; and it is probable that many others in Scotland cultivated the potato in their gardens about that time. It was not, however, grown in the open fields in Scotland till the year 1728, when Thomas Prentice, a day labourer, first cultivated potatoes at Kilsyth. The success was such, that every farmer and every cottager followed his example; and for many years past it has become a staple article. Thomas Prentice, by his industry, had saved £200 sterling, which he sunk for double interest. Upon this he subsisted for many years, and died at Edinburgh in 1792, aged eighty-six years. This plant thrives as well in Europe as it does in America. In this island, particularly, it is quite at home; and there is hardly a soil, but, with a little pains, may be made to produce the potato. The potato may be cultivated in every habitable part of the globe; but with variable success. The heat of the West Indies is too great for it. In Jamaica, however, and other mountainous islands, where they have all climates, it has been produced in great perfection. On account of the potato being a species of *solanum*, or night-shade, there were many who were prejudiced against it, alleging it was narcotic. In Burgundy, we find the culture and use of potatoes in food interdicted, as a poisonous and mischievous root. Amongst other effects, it was accused of producing leprosy and dysentery. Potatoes exposed a few days to the sun and weather acquire a green colour, bitter taste, and a narcotic quality. In this state they are not fit for eating; but there is not

the smallest foundation for the other allegations. Prejudice and ignorance have long yielded to experience and truth; and all mankind at this day agree, that there is no food so wholesome, more easily procured, or less expensive, than the potato. It constitutes the chief article of food to immense numbers of people, and may be converted to the support of all domestic animals, whether raw, boiled, or roasted.

POTCH, *v. a.* Fr. *pocher*. To thrust out the eyes as with a thumb. To thrust; push.

POTCH, *v. a.* Fr. *pocher*. To poach; to boil slightly. Commonly written *POACH*, which see.

POTEMKIN (George Prince), a descendant of a Polish family, who entered into the service of Russia, and distinguished himself so much as to be appointed to the chief command by Catharine II. On the 17th December, 1788, he took the important fortress of Oczakow from the Turks, and obtained several other victories over them. The empress rewarded his services by loading him with riches and honors: and it is said that she intended to have made him sovereign of that part of his native country which she had dismembered, when he died in 1791, aged fifty-two.

POTENCY, *n. s.* Lat. *potentia, potens*.

POTENT, *adj.*

POTENTATE, } Power; efficacy; authority; potent is powerful;

POTENTLY, } forcible; strong; efficacious: potentate, a possessor of sovereign power:

potently follows the senses of potent.

Thus did the uncircumcised *potentates*

Of earth, debase religion in the sight  
Of those they ruled, who looking up beheld  
The fair celestial gift despised, enslaved;  
And mimicking the folly of the great,  
With prompt docility despised her too. *Pollok.*

All obeyed the superior voice  
Of their great *potentate*; for great indeed  
His name, and high was his degree in heaven.

*Milton.*

POTENGER (John), an English author, born at Winchester in 1647. He took the degree of B.A. in Corpus Christi College, Oxford; and entering the Temple, was called to the bar. He is chiefly known by his *Life of Agricola*, from Tacitus; and his *Pastoral Reflection on Death*, a poem. He died at Dorchester, in 1733.

POTENT, or POTENCE, in heraldry, a term for a kind of cross whose ends all terminate like the head of a crutch. It is otherwise called the Jerusalem cross. See diagram.



POTENTIAL, *adj.* } Fr. *potenciel*; Lat.

POTENTIAL'ITY, *n. s.* } *potentialis*. Existing in

POTENTIALLY, } possibility only; having effect as distinct from an actual property: efficacious: potentiality is possibility: potentially corresponds with potential.

The magnifico is much beloved,  
And hath in his effect a voice *potential*,  
As double as the Duke's. *Shakespeare. Othello.*  
The cautery is either actual or *potential*.

*Markham.*

The true notion of a soul's eternity is this, that the future moments of its duration can never be all



past and present; but still there will be futurity and potentiality of more for ever and ever. *Bentley.*

This duration of human souls is only potentially infinite. *Id.*

**POTENTIAL**, in grammar, is an epithet applied to one of the moods of verbs. The potential is the same in form with the subjunctive, and is, according to Ruddiman, implied in that mood; for which reason that grammarian rejects it: but others observe that it differs from the subjunctive in this that it always carries with it the signification of power, will, or duty. It is sometimes called the permissive mood, because it often implies a permission or concession to do a thing.

**POTENTIAL CAUTERY**, in medicine, denotes the consuming, or reducing to an eschar, any part of the human body by a caustic alkaline or metallic salt, &c., instead of a red-hot iron, which last is called the actual cautery.

**POTENTILLA**, silver-weed, wild tansy, or cinquefoil, a genus of the pentagynia order, and icosandria class of plants; natural order thirty-fifth, *senticosæ*: *CAL.* decemfid: there are five petals: *SEEDS* roundish, naked, and affixed to a small dry receptacle. The species are six:

1. *P. argentea*, silvery upright potentilla, has upright stalks, branching a foot high; and five-lobed leaves, having the lobes wedge-shaped, cut on the edges, hoary, and white underneath, and the branches terminated by small yellow flowers.

2. *P. fragaroides*, the strawberry-like potentilla, has a somewhat tuberous root, furnished with many long fibres, long trailing shoots, rooting at the joints; pinnated, mostly three-lobed leaves, having oval lobes, with the extreme lobe the largest, and clusters of small white flowers. This species bears a great resemblance to the small sterile strawberry plants.

3. *P. fruticosa*, the shrubby potentilla, commonly called shrub cinquefoil. This rises with a short shrubby stem, dividing into a branchy full head, three or four feet high; closely garnished with pinnated leaves of five oblong, narrow, acute-pointed folioles, pale green above, and whitish underneath; and the branches terminated by clusters of large, spreading, yellow flowers. This is a beautiful deciduous flowering shrub, worthy of a place in every curious collection. It grows wild in Yorkshire, and other northern parts of England, &c., but has been long cultivated in gardens as an ornamental shrub.

These plants flower in June and July; the flowers are composed each of five roundish petals, and about twenty stamina. They are all very hardy, and may be employed in the different compartments of the pleasure ground. Their propagation is very easy. The shrubby potentilla may be propagated abundantly by suckers, layers, and cuttings; all of which will readily grow, and make plants in one year, which, after having two or three years growth in the nursery, will be fit for any of the shrubbery compartments. The herbaceous kinds may be propagated by parting the roots in autumn or spring, or by seed in any of those seasons.

**POTERIUM**, garden burnet, a genus of the polyandria order, and monœcia class of plants; natural order fifty-fourth, *miscellanæ*: *MALE*

*CAL.* tetraphyllous: *COR.* quadripartite: there are from thirty to forty stamina. *FEMALE CAL.* tetraphyllous: *COR.* quadripartite: there are two pistils: the berry is formed of the indurated tube of the corolla. The species are three:

1. *P. hybridum*, hybrid agrimony-leaved burnet, rises with upright, taper, closely gathered stalks, two feet high; pinnated odoriferous leaves of three or four pairs of sawed lobes, terminated by an odd one; and the stalks terminated by long foot-stalks, dividing into smaller, each supporting a small roundish spike of flowers. This species often proves biennial; but, by cutting down some of the stalks before they flower, it will cause it to multiply at bottom, and become abiding.

2. *P. sanguisorba*, the common garden burnet, has fibry perennial roots, crowned by a large tuft of pinnated leaves, or six or seven pair of sawed lobes, terminated by an odd one; upright angular stalks, dividing, and branching a foot and a half high, terminated by oblong spikes of purplish red flowers. This species grows wild in England, in chalky soils; but has been long cultivated as a choice sallad herb for winter and spring use, it being of a warm nature: the young leaves are the useful parts. It is perennial in root, and retains its radical leaves all the year; but the stalks are annual.

3. *P. spinosum*, shrubby spinous burnet of Crete, has a shrubby stem and branches, rising about a yard high, armed with spines; small pinnated ever-green leaves, of six or seven pairs of lobes, terminated by an odd one, and the branches terminated by small heads of greenish flowers. All these species flower in June and July, succeeded by ripe seeds in autumn. They are naturally perennial; but the two herbaceous ones are abiding in root only; the other in root, stem, and branches: the two former are hardy, and the third requires shelter in winter. The second sort merits culture in every kitchen-garden for winter and spring salads. The third sort must be kept always in pots, to have shelter in winter. They are all easily propagated, the second sort by seed and by parting the roots. The first sort may also be increased by seeds and slips off the root, as for the former sort: and the propagation of the third is by slips or cuttings of the branches in spring and summer, planted in pots, and placed under glasses, giving shade and water; or it might be forwarded more by plunging them in a hot-bed. Burnet is of a heating, drying nature, cordial and alexipharmic.

**POTGUN**, *n. s.* A corruption of *popgun*. A gun which makes a small smart noise.

An author thus who pants for fame,  
Begins the world with fear and shame,  
When first in print, you see him dread  
Each *potgun* levelled at his head.

*Swift's Miscellanies.*

**POTH'ECARY**, *n. s.* A corruption of *apothecary*. *Lat.* *apothecarius*. One who compounds and sells physic.

Modern *'pothecaries*, taught the art  
By doctors' bills to play the doctor's part,  
Bold in the practice of mistaken rules,  
Prescribe, apply, and call their masters fools.

*Pope*

**POTHER**, *n. s.* This word is sometimes written *podder*, sometimes *pudder*, and is derived by Junius from Fr. *foudre*, thunder, by Skinner from Dut. *peuteren* or *peteren*, to shake or dig; and more probably, by a second thought, from Fr. *podre*, dust. See **BOTHER**. Bustle; tumult; flutter. A low word.

Such a *pother*,  
As if that whatsoever god, who leads him,  
Were crept into his human powers,  
And gave him graceful posture.

*Shakspeare. Coriolanus.*

He suddenly unties the poke,  
Which from it sent out such a smoke,  
As ready was them all to choke,  
So grievous was the *pother*. *Drayton.*

Some hold the one, and some the other,  
But bowsoe'er they make a *pother*. *Hudibras.*  
He that loves reading and writing, yet finds certain seasons wherein those things have no relish, only *pothers* and wearies himself to no purpose. *Locke.*

I always speak well of thee,  
Thou always speak'st ill of me;  
Yet after all our noise and *pother*,  
The world believes nor one nor t'other. *Guardian.*

'Tis yet in vain to keep a *pother*  
About one vice, and fall into the other. *Pope.*  
What a *pother* has been here with Wood and his brass,  
Who would modestly make a few half-pennies pass!  
*Swift.*

**POTHOS**, in botany, a genus of the polyandria order, and gynandria class of plants. The spathe or sheath is a simple spadix covered: CAL. none: petals four, and as many stamina; the berries are dispermous. Species four, American plants.

**POTIDÆA**, a town of Macedonia, in the peninsula of Pallene. It was founded by a colony of Corinthians, and became tributary to the Athenians, from whom Philip II. of Macedon took it, and gave it to the Olynthians, whom he afterwards extirpated. Cassander repaired and enlarged it, and named it Cassandria.

**POTION**, *n. s.* Fr. *potion*; Lat. *potio*. A draught; commonly a physical draught.

For tastes in the taking of a *potion* or pills, the head and neck shake. *Bacon's Natural History.*

The earl was by nature of so indifferent a taste, that he would stop in the midst of any physical *potion*, and, after he had licked his lips, would drink off the rest. *Wotton.*

Most do taste through fond intemperate thirst;  
Soon as the *potion* works, their human countenance,  
The' express resemblance of the gods, is changed  
Into some brutish form of wolf or bear. *Milton.*

**POTNIÆ**, a town of Bœotia, where Bacchus had a temple. The Potnians, having murdered the priest of Bacchus, were ordered by the oracle to sacrifice a young man annually. This horrible sacrifice having continued some years, Bacchus interposed and substituted a goat. Paus. 9. c. 8.

**POTOMAC**, a river of the United States, which rises in two branches, the north and south, originating in and near the Alleghany mountains, and forming, through its whole course, part of the boundary between Virginia and Maryland. It passes by Shepherdstown, Georgetown, Washington city, Alexandria, Port Tobacco, &c.; and

flows into Chesapeake Bay, between Point Lookout and Smith's Point. It is seven miles and a half wide at its mouth, and one mile and a quarter at Alexandria, 290 miles from the Ocean. The termination of the tide water is above 300 miles from the sea, and the river is navigable for ships of the greatest burden through nearly that distance. Above the tide water the river has three considerable falls, those above Georgetown are now passable in boats. Its length above the tide is upwards of 300 miles through an inhabited country. Its junction with the Shenando at Harper's Ferry is regarded as a great curiosity. The river has seven fathoms of water at its mouth, five at St. George's island, four and a half at Lower Matchodic, and three at Swan's Point, and thence to Alexandria.

**POTOMAC ACADEMY**, in Prince George county, Valencia, near the Potomac; twenty-three miles east of Fredericksburg.

**POTOMAC CREEK**, a river of Virginia, which runs into the Potomac. Long. 77° 22' W., lat. 38° 24' N.

**POTOSI**, a government once belonging to Peru, but added by the Spanish government to the viceroyalty of Buenos Ayres, and now a province in the republic of Bolivia. It is bounded on the north by the cordillera of Vilcanota, which separates it from the Peruvian provinces, and by countries inhabited by wandering tribes; on the east by the mountains of Arequipa, the Pacific Ocean, and the Chilian Andes; on the west by the governments of Paraguay and Buenos Ayres; and on the south by that of Buenos Ayres. Great part of it is full of mountains, ravines, and chasms, of a very cold temperature, and almost barren of vegetable productions; in other parts the country is covered with deserts, forests, vast plains, and mountain streams expanding into rivers. The Provincias de la Sierra, which lie near the Andes, are the most populous.

Potosi, a city of the above province and district of Porco, is situated in a narrow glen on the river of this name, and on the south side of the mountain which contains the Potosi mines. The environs are barren, and the climate cold; the valleys being destitute of wood, the sides of the hills covered only with moss, and their summits with eternal snows. A few vicunas are the only animals now and then seen grazing in this elevated region.

The *silver mine* of Potosi is by far the most productive of the whole of those in this government. The mountain from which the metal is extracted is of a conical form, about six leagues in circumference, and 4182 feet above the neighbouring plains. The discovery of its treasure was owing entirely to the accident we have adverted to in our article **AMERICA, SOUTH**, which see: a Peruvian, named Diego Hualpa, while chasing some chamois among the rocks, in his ascent laid hold of a small shrub, whose roots giving way disclosed to his view an immense vein of silver, which has been since distinguished by the name of La Rica, or the Rich. The Indian concealed the circumstance for a time from all his friends, and only had recourse to this treasure to supply his occasional wants; but the obvious change in his fortune had excited the

suspicious of one of its companions, who by recent evidence, drew from him the secret and upon whose sixth quarter he soon after revealed it in his master's statement. The information was in another respect than the mine was opened; and it was formally registered 1st of April, 1565. Since that time it has been constantly wrought, and the silver which has paid the royal duties from this mine, has been valued at 175,000,000 of pesos castellanos, equal to 2,187,500,000 marcos. The mountain is now almost completely exhausted, and is perforated with above 300,000 low of which, however, are more than seventy parts deep. It is opened at the base, and falling, but unfortunately, descends into the bowels, and near the veins of silver, in these parts which are called by the miners *cañoncillos* and are about six feet high and eight feet broad, the air is cold and unwholesome, and the labourers work there alternately night and day, scarcely taking rest they should embrace the ore.

On the first discovery of the mine of Potosi, the metal was much purer than at present, being now inferior to many of the other mines. It is the abundance of the ore alone which renders it worth working. According to Acosta, the average contents of silver in the crude ore were, in 1574, from eight to nine marks per quintal; and the material which yielded fifty marks per quintal were considered as extremely rich. Since the beginning of the eighteenth century, however, they reckon only from three to four marks per quintal, or from  $\frac{2}{3}$  to  $\frac{1}{3}$  per quintal. A canon contains about 50 cwt. From this it appears that the mean rates of the minerals were diminished in the proportion of 170 to one; but, what is surprising, the quantity of silver extracted from the mines of Potosi has only diminished in the proportion of four to one, according to the following calculations, which are from Humboldt.

1. From the opening of the mines of Potosi in 1545 to the year 1556, when the royal duties were first recorded with accuracy, Ulioa, upon the authority of Don Sebastiani Sandoval y Guzman, who published an account of these mines in 1634, entitled *Pretensiones del Potosi*, makes the total produce which paid duty to be 613,000,000 of piastres, making a yearly average of 55,726,600 piastres, or 6,556,000 marks of silver. This immense sum, however, Humboldt, upon unquestionable data, has reduced to 127,500,000 piastres, or 15,000,000 of marks, making an annual produce of nearly 1,363,636½ marks.

2. The royal duties paid on the silver extracted from the mines of Potosi, between the 1st of January 1556, and 31st of December 1578, during which the fifth only was paid, amounted to 9,901,906 piastres, making a total produce of 49,509,530 piastres; or 5,765,827 marks of silver, which, for twenty-three years, makes the average annual produce of 256,688 marks.

3. The duties paid from the 1st of January 1579, to the 19th of July 1736, during which one and a half per cent. *de covos* was first paid, and then the fifth of the remaining 98½ piastres, amounted to 129,417,273 piastres, making a total produce of nearly 610,458,835 piastres, or

71,313,669½ marks of silver, which, for 157 years and a half, is at an annual average produce of nearly 453,999½ marks.

4. Between the 30th of July 1736 and the 21st of December 1739, during which the one and a half per cent. *de covos* and the half of the fifth only were paid, the royal duties amounted to 14,347,604 piastres, making a total produce of 108,120,674½ piastres, or 13,074,604½ marks of silver, which, for three years and a half, makes an annual produce of nearly 281,758 marks.

5. From 1739 to 1803 we have no account of the royal duties; but during that period the total produce of Potosi, according to the records of the mine, was 42,000,000 of piastres, or 5,411,764 marks, making a yearly average of 366,594½ marks.

It appears, therefore, that the annual produce of the last period is little more than a fourth of that of the first; but, in giving the average produce for such long periods, the gradual diminution or increase of the quantity of silver extracted from these mines could not be distinctly marked. We may therefore observe that, during the second period, when the royal duties were first correctly registered, the king's fifth varied from 500,000 to 800,000 piastres; and that, during the first fifty years of the third period, the duties varied from 1,000,000 to 1,500,000 piastres; and then gradually diminished until 1735, when they only amounted to 271,621 piastres, 6 reals. From 1737 to 1789, the increase was equally gradual from 133,704 to 335,468 piastres. We may also remark that, in these calculations, we have uniformly valued the piastre at only eight reals de plata, although, until near the close of the sixteenth century, the Spaniards reckoned by piastres of 480 maravedis, or nearly 13½ reals de plata. In estimating, therefore, the total produce of these mines from 1545 to 1803, allowance must be made for this low valuation.

The quantity of silver extracted from the mines of Potosi during the

	Marks.
1st period, was . . . . .	15,000,000
2nd . . . . .	5,765,827
3rd . . . . .	71,818,686
4th . . . . .	15,074,044
5th . . . . .	5,411,764
	<hr/>
	113,070,321
Allowance for the value of the piastre before 1600 . . . . .	15,000,000
	<hr/>
	128,070,321
To this may be added one-fourth more, on account of the enormous contraband at former periods . . . . .	32,017,580
	<hr/>
Total produce . . . . .	160,087,901

See a more detailed statement of the produce of late years in the article already referred to.

Nothing, according to Helms, can equal the ignorance with which the mining is here carried on. The mines, many of them, are filled with

water, which, by the application of proper machinery, might be easily drained off. The methods employed for this purpose are, however, ill contrived and ineffectual. Mr. Helms saw one drain which had been begun in 1779, and had, at an incredible expense, been carried two miles. This drain, even at its mouth, was too high, and it had been made to slope one yard in every 132; so that it could not possibly free many of the pits from the water with which they were overwhelmed. 'Still greater ignorance,' says Mr. Helms, 'was, if possible, displayed by the directors of the smelting houses and refining works at Potosi. By their method of amalgamation, they were scarcely able to gain two-thirds of the silver contained in the paco-ore; and, for every mark of pure silver gained, they destroyed one, and frequently two, marks of quicksilver. Indeed all the operations at the mines of Potosi, the stamping, sifting, washing, quickening, and roasting the ore, are conducted in so slovenly, wasteful, and unscientific a manner, that to compare the excellent method of amalgamation invented by baron Born, and practised in Europe, with the barbarous process used by these Indians and Spaniards, would be an insult to the understanding of my readers. The tools of the Indian miner are very badly contrived and unwieldy. The hammer, which is a square piece of lead of twenty pounds weight, exhausts his strength. The iron, a foot and a half long, is a great deal too inconvenient, and in some narrow places cannot be made use of. The thick tallow candles wound round with wool, vitiate the air. In the royal mint at Potosi, where from 500,000 to 600,000 marks of silver, and about 2000 marks of gold, are annually coined, affairs were not better conducted. Every hundred weight of refined copper used for alloy in the gold and silver coin cost the king £35, through the gross ignorance of the overseers of the work, who spent a whole month in roasting and calcining it, and frequently rendered it quite unfit for the purpose.' These various evils the German commissioners, sent over by the king of Spain to inspect the mines, endeavoured to remove. They constructed a new laboratory, according to the most improved model, by which the copper ores used for alloy could be refined in four hours and a half, and for one-twentieth part of the expense incurred by the former process: they also erected machinery for the draining of the mines. New amalgamation works were also erected, and suitable instructions given to the persons employed. 'As soon as the water in the pits,' Helms observes, 'can be got under, the mines of Potosi will be in a more flourishing condition than ever. The total want of timber, however, on the naked ridge of mountains on which Potosi is situated, very much retards the work.'

**Potosi**, formerly Mine-au-Burton, a post town and capital of Washington county, Missouri territory; forty-five miles west of St. Genevieve, and sixty S.W. of St. Louis.

**Potosi**, **SAN LOUIS**, an extensive intendency of Mexico or New Spain, under the Spanish government, whose territorial limits it is scarcely possible accurately to ascertain, it being sur-

rounded by deserts, or countries inhabited by wandering and independent tribes of Indians. On the south it is bounded by the intendancies of Vera-Cruz, Mexico, and Guanajuato; on the east by the gulf of Mexico, and on the west by Zacatecas and Durango. This immense district includes, therefore, a greater surface than Europe or Spain; but though gifted by nature with the most precious productions, and situated under a serene sky, it is quite wild as to cultivation in most parts, and more thinly peopled than Asiatic Russia. Its position on the eastern limits of New Spain, the proximity of the United States, the easy communication with the colonists of Louisiana, and various other circumstances, concur, however, to favor its progress towards civilisation and prosperity.

On the coast, which is 230 leagues in extent, are a number of lagunas, or salt water lakes. The capital is of this name, and contained in Humboldt's time 12,000 inhabitants. It is situated on the eastern side of this table-land west of the sources of the Rio de Panuca.

**POTSCHINKI**, a town of European Russia, in the government of Nischnei-Novgorod. It has a traffic in cattle, and 4000 inhabitants, and here is kept by government a stud of horses, which supplies a regiment of life-guards. 117 miles S. S. E. of Nischnei-Novgorod.

**POTSDAM**, a province of Brandenburg, Prussia, comprehending the former districts of the Ucker Mark, the Mark of Priegnitz, and the greatest part of the Middle Mark. It is situated between Pomerania and West Prussia on the north, and the province of Saxony on the south and west: Berlin, with a small district around, forms a distinct government. Towards the north-west this province is bounded by the Elbe and the Havel, and on the north-east by the Oder. Its area is about 8000 square miles, divided into the following thirteen circles:—

Lower Barnim,	West Havelland,
Upper Barnim,	East Priegnitz,
Teltow-Storkow,	West Priegnitz,
Zauch-Belzig,	Ruppin,
Juterbock-Lucken-	Prenzlau,
walde,	Templin,
East Havelland,	New Angermunde.

This track is one extensive low plain, varied only occasionally by hills of slight elevation. The soil, though for the most part a light sand, sometimes barren and even drifting, contains spots, particularly on the rivers, remarkable for their fertility. The climate is not cold, and, since a number of the lakes have been drained, it is reckoned healthy. The chief mineral here is marsh iron ore, which affords about twenty per cent. of metal. The inhabitants, about 500,000, are in general industrious, and carry on manufactures of woollens, cotton, and linen. The towns are small, the principal, after Potsdam, being Brandenburg, Prenzlau, Spandau, and Ruppin.

**POTSDAM**, the chief town of the above government, is of a square form and situated on the north bank of the Havel, which here spreads its waters into a succession of small lakes. Potsdam, since the close of the seventeenth century,

has been the frequent residence of the court of Berlin, but is indebted for its chief improvements to Frederic II. The new town was either built or repaired entirely by that prince: the fronts of several of the streets are all of stone, but the rest of the houses are finished in a far inferior style. The streets are not as yet all paved. On the whole, however, Potsdam may vie in beauty with Manheim, or any German town. It is surrounded by a wall and ditch, and has four gates toward the land, and four toward the river; on the banks of which is the Havel, a magnificent structure, begun in 1660, and extended progressively during the subsequent reigns. Its finest ornaments are a colonnade, a cupola, and a marble staircase. In the front is a square for manœuvring troops; and along the river extensive gardens. Connected with it also are a theatre, menagerie, and noble stables. The town-house was built in 1754, on the plan of that of Amsterdam. There are in Potsdam extensive barracks; a great hall for exercising the troops in bad weather; and in the garrison church statues of Mars and Bellona. Here also is the tomb of Frederick II. There are in the town six other churches and a Jewish synagogue. The market-place is ornamented by statues of the kings of Prussia and an obelisk. The lyceum, two public schools of inferior extent, and one belonging to the garrison; the infirmary itself, a poor-house, and an orphan-house on a large scale, for the children of soldiers, are other public establishments worth notice.

The population of Potsdam, exclusive of military, is about 25,000; the former amount in general to the number of 6000 or 8000. In the absence of the court, Potsdam seems deserted. Its numerous manufactures are all on a small scale: but brewing is here, as in other German towns, a business of great extent; and the cultivation of gardens in the neighbourhood supplies no small employment. The palace of Sans Souci, the favorite retreat of 'the great Frederick,' is three-quarters of a mile to the north-west, and stands on the ascent of an eminence. It is only one story in height, with a circular pavilion at each end: in one is the library of Frederick, exactly in the state it was left at his death. Sans Souci has two appended buildings for a collection of paintings, and for other court entertainments. In the garden is a cabinet of statues, gems, and medals. Two miles to the west is a palace begun towards the close of the eighteenth century on a magnificent scale, but not likely to be soon finished. The structure called the marble palace is in the midst of a garden at some distance from Sans Souci. Fifteen miles W.S.W. of Berlin, and sixty-one E. N. E. of Dresden.

**POTSDAM**, a post town of St. Lawrence county, New York; ninety miles west of Plattsburg, and 150 N.N.W. of Albany. It is a flourishing town. The principal village is situated on the Racket, where there are fine falls, which afford excellent seats for mills and manufactories. A weekly newspaper is published here.

**POTT** (Percival), F. R. S., was born in London in 1713. He received the rudiments of his education at a private school at Darne in Kent;

and became an apprentice to Mr. Nourse, one of the surgeons of St. Bartholomew's Hospital; of which hospital, in 1744-5, he was elected an assistant; and, in 1749, appointed one of the principal surgeons. In 1746 he married the daughter of Robert Cruttenden, Esq. His first publication is said to have been planned in 1756, during his confinement, in consequence of a compound fracture of the leg: from that time his pen was seldom long unemployed. His practice and his reputation were now rapidly increasing: in 1764 he was elected F. R. S.; and afterwards was complimented with honorary diplomas from the Royal Colleges of Surgeons in Edinburgh and Dublin. In 1787 he resigned the office of surgeon to St. Bartholomew's Hospital, 'after having served it,' as he used to say, 'man and boy, half a century;' and on the 22d of December, 1788, after an illness of eight days, he expired. He published a great number of treatises on various branches in surgery; particularly, *On Tumors which soften the Bones; On Ruptures; On the Hydrocele; On Fistula Lachrymalis; On Hernia of the Bladder and Stone; On Fistula in Ano; On Fractures and Dislocations; On Wounds of the Head; On the Cataract, Polypus of the Nose, Cancer of the Scrotum, Ruptures, and Mortification of the Toes.* All these have been collected and published in 1 vol. 4to.

**POTTER** (Christopher), a learned English divine, born in 1591, and educated at Oxford. In 1633 he published his *Answer to a late Popish Plot, entitled Charity Mistaken*, which he wrote by special order of king Charles I., whose chaplain he then was. In 1634 he was appointed dean of Worcester; and in 1640 vice-chancellor of the university of Oxford; in the execution of which office he met with considerable hindrance from the members of the long parliament. Upon the breaking out of the civil wars, he sent all his plate to the king, declaring 'that he would rather, like Diogenes, drink in the hollow of his hand, than that his majesty should want;' and he afterwards suffered much for the royal cause. He was accordingly nominated dean of Durham in 1646, but was prevented from being installed by his death, which happened about two months after. 'He was a person learned and religious, exemplary in his conversation, courteous in his carriage, of a sweet and obliging nature, and of a comely presence.' He was remarkable for his charity to the poor.

**POTTER** (John), D. D., archbishop of Canterbury, was the son of a linen-draper at Wakefield, in Yorkshire, where he was born about 1674. He studied at University College, Oxford; and at the age of nineteen published *Variante Lectiones et Notæ ad Plutarchi Librum de Audiendis Poetis; et ad Basilii magui orationem ad Juvenes, quomodo cum fructu legere possint Græcorum Libros*, 8vo., 1693. In 1697 came out his *Lycophron*, in folio; which is reckoned the best edition of that obscure writer: soon after he published his *Antiquities of Greece*, 2 vols. 8vo. These works established his literary reputation, and engaged him in a correspondence with Grævius and other learned foreigners. In 1706 he was made chaplain to the queen; in

1715 bishop of Oxford; and in 1737 he succeeded archbishop Wake in the see of Canterbury; which high station he supported with much dignity until his death in 1747. He was a learned and exemplary churchman; but strongly tinctured with the pride of office; and disinherited his eldest son for marrying below his rank. His Theological works, containing Sermons, Charges, Discourses on Church Government, and Divinity Lectures, were printed at Oxford, in 3 vols. 8vo., 1753.

POTTER (Robert), a divine of the church of England, was born in Norfolk in 1721, and educated at Emanuel College, Cambridge, where he took his bachelor's degree in 1741. His first preferment was the vicarage of Scarning in Norfolk, where he wrote poems in imitation of Pope, which were published in 1 vol. 8vo., in 1774. In 1777 appeared his translation of Æschylus, with notes, 4to.; reprinted in 1779 in 2 vols. 8vo. In 1781 came out the first volume of his translation of Euripides, and the second in the year following. In 1788 he printed his Sophocles, and his school-fellow, lord Thurlow, gave him a prebend in the church of Norwich: bishop Bagot presented him, about the same time, to the vicarages of Lowestoft and Kessingland. He died at Lowestoft in 1804. Besides the above, Mr. Potter wrote Observations on the Poor Laws; an Answer to Dr. Johnson's Lives of the Poets; A Translation of the Oracle concerning Babylon, &c.

POTTERY, the manufacture of earthen-ware, or the art of making earthen vessels. See DELFT, FORCELAINE, &c. The wheel and lathe are the usual instruments in pottery; the first for large works, and the last for small. The potter's wheel consists principally in the nut, which is a beam or axis, whose foot or pivot plays perpendicularly on a free-stone sole or bottom. From the four corners of this beam, which does not exceed two feet in height, arise four iron bars, called the spokes of the wheel, which, forming diagonal lines with the beam, descend, and are fastened at bottom to the edges of a strong wooden circle, four feet in diameter, perfectly like the felloe of a coach wheel, except that it has neither axis nor radii, and is only joined to the beam, which serves it as an axis, by the iron bars. The top of the nut is flat, of a circular figure, and a foot in diameter; and on this is laid the clay which is to be turned and fashioned. The wheel thus disposed is encompassed with four sides of four different pieces of wood fastened on a wooden frame; the hind piece, which is that on which the workman sits, is made a little inclining towards the wheel; on the fore pieces are placed the prepared earth; on the side piece he rests his feet, and these are made inclining to give him more or less room. Having prepared the earth, the potter lays a round piece of it on the circular head of the nut, and, sitting down, turns the wheel with his feet till it moves with the proper velocity; then, wetting his hands with water, he presses his hand or his finger's end into the middle of the lump, and thus forms the cavity of the vessel, continuing to widen it from the middle; thus turning the inside into form with one hand,

while he proportions the outside with the other, the wheel constantly turning all the while, and he wetting his hands from time to time. When the vessel is too thick, he uses a flat piece of iron, somewhat sharp on the edge, to pare off what is redundant; and, when it is finished, it is taken off from the circular head by a wire passed under the vessel. The potter's lathe is also a kind of wheel, but more simple and slight than the former: its three chief members are an iron beam or axis three feet and a half high, and two feet and a half diameter, placed horizontally at the top of the beam, and serving to form the vessel upon: and another larger wooden wheel, all of a piece, three inches thick, and two or three feet broad, fastened to the same beam at the bottom, and parallel to the horizon. The beam or axis turns by a pivot at the bottom in an iron stand. The workman gives the motion of the lathe with his feet, by pushing the great wheel alternately with each foot, still giving it a greater or less degree of motion as his work requires. They work with the lathe with the same instruments, and after the same manner, as with the wheel. The mouldings are formed by holding a piece of wood or iron cut in the form of the moulding to the vessel, while the wheel is turning round; but the feet and handles are made by themselves, and set on with the hand; and, if there be any sculpture in the work, it is usually done in wooden moulds, and stuck on piece by piece on the outside of the vessel. The art of making pottery is intimately connected with chemistry. For Mr. Wedgwood's remarkable improvements in this art see STAFFORDSHIRE.

The process of manufacturing *stoneware* is described by Dr. Watson as follows:—

Tobacco-pipe clay from Dorsetshire is beaten much in water. By this process, the finer parts of the clay remain suspended in the water, while the coarser sand and other impurities fall to the bottom. The thick liquid, consisting of water and the finer parts of the clay, is farther purified by passing it through hair and lawn sieves, of different degrees of fineness. After this, the liquid is mixed (in various proportions for various wares) with another liquor, of as nearly as may be the same density, and consisting of flints calcined, ground, and suspended in water. The mixture is then dried in a kiln; and, being afterwards beaten to a proper temper, it becomes fit for being formed at the wheel into dishes, plates, bowls, &c. When this ware is to be put into the furnace to be baked, the several pieces of it are placed in the cases made of clay, called seggars, which are piled one upon another in the dome of the furnace. A fire is then lighted; and when the ware is brought to a proper temper, which happens in about forty-eight hours, it is glazed by common salt. The salt is thrown into the surface, through holes in the upper part of it, by the heat of which it is instantly converted into a thick vapor; which, circulating through the furnace, enters the seggar through holes made in its side (the top being covered to prevent the salt from falling on the ware), and, attaching itself to the surface of the ware, it forms that vitreous coat upon the surface which

is called its glaze. The yellow or queen's-ware is made of the same materials as the flint-ware; but the proportion in which the materials are mixed is not the same, nor is the ware glazed in the same way. The flint-ware is generally made of four measures of liquid flint, and of eighteen of liquid clay. The yellow ware has a greater proportion of clay in it. In some manufactories they mix twenty, and in others twenty-four, measures of clay, with four of flint. These proportions, if estimated by the weight of the materials, would probably give for the flint-ware about 3 cwt. of clay to 1 cwt. of flint, and for the yellow ware somewhat more clay. The proportion, however, for both sorts of ware depends very much upon the nature of the clay, which is very variable even in the same pit. Hence a previous trial must be made of the quality of the clay, by burning a kiln of the ware. If there be too much flint mixed with the clay, the ware, when exposed to the air after burning, is apt to crack; and, if there be too little, the ware will not receive the proper glaze from the circulation of the salt vapor. This glaze, even when it is most perfect, is in appearance less beautiful than the glaze on the yellow ware.

The yellow glaze is made by mixing together in water, till it becomes as thick as cream, 112 lbs. of white lead, 24 lbs. of ground flint, and 6 lbs. of ground flint-glass. Some manufactories leave out the glass, and mix only 80 lbs. of white lead with 20 lbs. of ground flint; and others, doubtless, observe different rules, of which it is very difficult to obtain an account.

The ware before it is glazed is baked in the fire. By this means it acquires the property of strongly imbibing moisture. It is therefore dipped in the liquid glaze, and suddenly taken out: the glaze is imbibed into its pores, and the ware presently becomes dry. It is then exposed a second time to the fire, by which means the glaze it has imbibed is melted, and a thin glassy coat is formed upon its surface. The color of this coat is more or less yellow, according as a greater or less proportion of lead has been used. The lead is principally instrumental in producing the glaze, as well as in giving it the yellow color; for lead, of all the substances hitherto known, has the greatest power of promoting the vitrification of the substances with which it is mixed. The flint serves to give a consistence to the lead during the time of its vitrification, and to hinder it from becoming too fluid, and running down the sides of the ware, and thereby leaving them unglazed.

The yellowish color which lead gives when vitrified with flints, may be wholly changed by very small additions of other mineral substances. Thus, to give one instance, the beautiful black glaze, which is fixed on one sort of the ware made at Nottingham, is composed of twenty-one parts by weight of white lead, of five of powdered flints, and of three of manganese. The queen's-ware at present is much whiter than formerly.

The coarse stoneware made at Bristol consists of tobacco-pipe clay and sand, and is glazed by the vapor of salt, like Staffordshire flint-ware; but it is far inferior to it in beauty.

**POTTLE**, *n. s.* From pot. A liquid mea-

sure containing four pints. Sometimes used for a tankard, or pot out of which glasses are filled.

Roderigo hath to-night caroused

Potations *pottle* deep.

*Shakspeare.*

The oracle of Apollo

Here speaks out of his *pottle*,

Or the Tripes his tower bottle.

*Ben Jonson.*

**POUCH**, *n. s.* Fr. *poche*. Sax. *þoga*. A small bag; a pocket.

In January husband that *poucheth* the grotes,  
Will break up his lay, or be sowing of otes.

*Tusser.*

Tester I'll have in *pouch*, when thou shalt lack.

*Shakspeare.*

The spot of the vessel, where the disease begins, gives way to the force of the blood pushing outwards, as to form a *pouch* or cyst.

*Sharp's Surgery.*

The common heron hath long legs for wading, a long neck to reach prey, and a wide extensive throat to *pouch* it.

*Derham.*

From a girdle about his waist, a bag or *pouch* divided into two cells.

*Gulliver's Travels.*

**POUCH**, Fr. *giberne*, a case of black stout leather with a flap over it, which is generally ornamented by a brass crown, &c., for the battalion-men; a fuse for the grenadiers; and a bugle-horn for the light infantry. The pouch hangs from a cross belt, over the left shoulder, and is worn in that manner, by the infantry, for the purpose of carrying their ammunition. The pouches in use among the cavalry are smaller, which the French call *demie giberne*.

**POUCHARD** (Julian), a learned French critic, was born near Domfront, in Normandy, and educated at Mans, and at Paris, where he rendered assistance to M. Thevenot, in his edition of the Ancient Mathematicians. After this he was engaged some years in arranging the MSS. of the royal library. In 1701 he became an associate of the Academy of Inscriptions, to whose memoirs he contributed some valuable papers on the learning of the Egyptians. He next became editor of the *Journal des Sçavans*; and in 1704 was appointed professor of Greek, but died the year following, aged forty-nine. Besides the above works, he wrote a *Universal History from the Creation to the Death of Cleopatra*.

**POUGHKEEPSIE**, a township of the United States, the capital of Dutchess county, New York, situated on the east bank of the Hudson, about a mile east of the river, contains a court-house, jail, bank, academy, five houses of public worship; and had, in 1812, 422 dwelling-houses, and forty-nine stores, shops, &c. Many of the old houses are mostly of stone, but those recently erected are of brick and wood. Poughkeepsie is a flourishing town, in one of the most wealthy and best agricultural counties in the state, and has an extensive trade. Here are three printing-offices, from each of which is issued a weekly newspaper. Seventy-five miles north of New York. Population 4670.

**POVERTY**, *n. s.* Fr. *pauvreté*; Lat. *pau-pertus*. Indigence; necessity; want of riches.

My men are the poorest,

But *poverty* could never draw them from me.

*Shakspeare.*

There is in all excellencies in composition a kind of *poerty*, or a casualty of jeoparity. *Bacon.*

Such madness, as for fear of death to die, is to be poor for fear of *poerty*. *Denham.*

These by their strict examples taught, How much more splendid virtue was than gold; yet scarce their swelling thirst of fame could hide, And boasted *poerty* with too much pride. *Prior.*

There is such a state as absolute *poerty*, when a man is destitute not only of the conveniences, but the simple necessities of life, being disabled from acquiring them, and depending entirely on charity. *Rogers.*

**POVERTY BAY**, a bay on the east coast of New Zealand, in the South Pacific Ocean, called by the natives Taonerua, or Long Sand, discovered by Cook in the year 1769. This bay, in the form of a horse-shoe, is known by an island lying close under the north-east point. It obtained its name from the inhospitable behaviour of the natives. Long. 181° 36' W., lat. 33° 42' S.

**POULT**, *n. s.* } Fr. *poulet*; Lat. *pullus*. A }  
**POULTREY**, } young chicken.  
**POULTREYER**. }

If thou dost it half so gravely, so majestically, hang me up by the heels for a *poulterer's* hare. *Shakespeare.*

Several nasty trades, as butchers, *poulterers*, and fishmongers, are great occasions of plagues. *Harvey.*

What louder cries, when Ilium was in flames, Than for the cock the widow'd *poultry* made. *Dryden.*

The cock knew the fox to be a common enemy of all *poultry*. *L'Estrange.*

One would have all things little, hence has tried Turkey *poults*, fresh from the egg, in batter fried. *King.*

Soldiers robbed a farmer of his *poultry*, and made him wait at table, without giving him a morsel. *Swift.*

**POULTRY** comprehends all birds brought up in yards, as cocks, hens, capons, ducks, turkeys, &c. Under this class we may, therefore, reckon the common cock, the peacock, the turkey, the pintada or Guinea hen, &c. They all bear a strong similitude to each other, being equally granivorous, fleshy, and delicate to the palate. Many of the wild species of birds, when cooped up or caged, pine away, grow gloomy, and some refuse all sustenance whatever; none except those of the *poultry* kind grow fat, who seem to lose all remembrance of their former liberty, satisfied with indolence and plenty.

**POULTICE**, *n. s.* Fr. *pulte*; Lat. *pultis*. A cataplasm; a soft or mollifying application.

*Poultice* relaxeth the pores, and maketh the humour apt to exhale. *Bacon's Natural History.*

*Poultices* allayed pains, but drew down the humours, making the passages wider, and apter to receive them. *Temple.*

If your little finger be sore, and you think a *poultice* made of our vitals will give it ease, speak, and it shall be done. *Swift.*

**POUNCE**, *n. s. & v. a.* } Italian *ponzone*.  
**POUNCED**, *adj.* } Skinner.

**POUNCETBOX**, *n. s.* } Spanish *punzen*; Lat. *punctus*.

The claw or talon of a bird of prey; a powder thrown through a perforated box: to pierce

or perforate; pour or sprinkle through perforations: pouncet-box, a small perforated box.

As haggard hawk, presuming to contend With hardy fowl, about his able might, His weary *pounces*, all in vain doth spend To truss the prey too heavy for his flight. *Spenser.*

He was perfumed like a milliner, And, 'twixt his finger and his thumb, he held A *pouncetbox*, which ever and anon He gave his nose. *Shakespeare. Henry IV.*

The new dissembled eagle, now endued With beak and *pounces*, Hercules pursued. *Dryden.*

**POUNCE**, gum semdarach, pounded and sifted very fine, to rub on paper in order to preserve it from sinking, and to adapt it better for the reception of ink in writing. Pounce is also charcoal-dust, enclosed in a piece of muslin or open stuff, to be passed over holes pricked in work, in order to mark the lines or designs on paper, silk, &c., placed underneath, which are to be afterwards finished with a pen, needle, or other like instrument.

**POUND**, *n. s. & v. a.* } Sax. *þund*, þuman  
**POUNDRAGE**, *n. s.* } (whence in some  
**POUNDER**, *n. s.* } places they use the

word *pun*); Goth. Swed. and Dan. *pund*; Belg. *pond*; Lat. and Ital. *pondo*; Lat. *pondo*. A certain weight, certain sum of money (money being first weighed); to beat or grind by a weight or pestle: poundage is, a certain sum deducted from or paid upon a pound of money: a pounder is a heavy large pear; also a person or thing denominated from a certain number of pounds: as, a ten pounder, a gun that carries a bullet of ten pounds weight; or in ludicrous language a man with ten pounds a year; in like manner, a note or bill has been called a twenty pounder or ten pounder, from the sum it bears.

A *pound* doth consist of ounces, drams, scruples. *Wilkins.*

Tonnage and *poundage*, and other duties upon merchandizes, were collected by order of the board. *Clarendon.*

His mouth and nostrils poured a purple flood, And *pounded* teeth came rushing with his blood. *Dryden.*

Should their axle break, its overthrow Would crush, and *pound* to dust the crowd below, Nor friends their friends, nor sires their sons could know. *Dryden's Juvenal.*

Great Hannibal within the balance lay, And tell how many *pounds* his ashes weigh. *Dryden.*

Alcinous' orchard various apples bears, Unlike are bergamots and *pounder* pairs. *Id.*

She describes How under ground the rude Riphean race Mimick brisk cyder, with the brake's product wild Sloes *pounded*. *Phillips.*

He that said that he had rather have a grain of fortune than a *pound* of wisdom, as to the things of this life, spoke nothing but the voice of wisdom. *South's Sermons.*

Lifted pestles brandished in the air, Loud strokes with *pounding* spice the fabrick rend, And aromatiek clouds in spires ascend. *Garth.*

Opaque white powder of glass, seen through a microscope, exhibits fragments pellucid and colour-



less, as the whole appeared to the naked eye before it was *pounded*. *Bentley.*

None of these forty or fifty *pounders* may be suffered to marry under the penalty of deprivation.

*Swift.*  
That exchequer of medals in the cabinets of the great duke of Tuscany is not worth so little as an hundred thousand *pound*. *Peacham of Antiquities.*

He gave, whilst ought he had, and knew no bounds;

The poor man's drachma stood for rich men's *pounds*. *Harte.*

**POUND**, *n. s. & v. a.* From Sax. *pinđan*. A pinfold; an enclosure: to enclose in a pound.

Rather than they should *pound* us up. *Shakespeare.*

I ordered John to let out the good man's sheep that were *pounded* by night. *Spectator.*

I hurry,  
Not thinking it is levee-day,  
And find his honour in a *pound*,  
Hem'd by a triple circle round.

*Swift's Miscellanies.*

To **POUR**, *v. a. & v. n.* From the Welsh *burw*. Lat. *ruo*? To let or drive some liquid out of a vessel, or from one place or receptacle to another; to emit; send forth: as a verb neuter, to stream; flow; rush violently.

If they will not believe those signs, take of the water of the river, and *pour* it upon the dry land.

*Exodus iv. 9.*

A Samaritan bound up his wounds, *pouring* in oil and wine, and brought him to an inn. *Luke 10.*

London doth *pour* out her citizens;  
The mayor and all his brethren in best sort,  
With the plebeians swarming.

*Shakespeare. Henry V.*

As thick as hail,  
Came post on post; and every one did bear  
Thy praises in his kingdom's great defence,  
And *poured* them down before him. *Id. Macbeth.*  
The devotion of the heart is the tongue of the soul; actuated and heated with love, it *pours* itself forth in supplications and prayers. *Duppa.*

Your fury then boiled upward to a fume;  
But, since this message came, you sink and settle,  
As if cold water had been *poured* upon you.

*Dryden.*

If we had groats or sixpences current by law, that wanted one-third of the silver by the standard, who can imagine that our neighbours would not *pour* in quantities of such money upon us, to the great loss of the kingdom? *Locke.*

If the rude throng *pour* on with furious pace,  
And hap to break thee from a friend's embrace,  
Stop short. *Gay.*

All his fleecy flock  
Before him march, and *pour* into the rock,  
Not one or male or female stayed behind. *Pope.*

Is it for thee the linnet *pours* his throat?  
Loves of his own and raptures swell the note. *Id.*  
A ghastly band of giants,  
All *pouring* down the mountains, crowd the shore. *Id.*

**POUSSE**, *n. s.* The old word for pease; corrupted, as may seem, from pulse.—Spenser.  
But who shall judge the wager won or lost?  
—That shall yonder herd groom and none other,  
Which over the *pousse* hitherward doth post. *Spenser.*

**POUSSIN** (Nicholas), an eminent French painter, born in 1594, at Andel, in Normandy.

He was instructed for a few months by one Ferdinand Elle, a portrait painter, and spent a month with L'Allemand; after which he went to Italy to study the antique and bas relief, but neglected coloring. He was invited back to Paris by Louis XIII. who assigned him a pension with lodgings in the Thuilleries. Piqued by some insults from the faction of Vouet's school, he returned to Rome, where he died in 1665. He had during the whole of his life a perpetual demand for easel-pieces, for which he obtained large prices.

**POUSSIN**, or **DUGHET** (Gaspar). This painter, whose real name was Dughet, was born in Paris in 1660. He went to Rome to see his sister, who was married to Nicholas Poussin; under whose instruction he became one of the best landscape painters that ever appeared. While he continued at Rome he assumed the name of his brother-in-law and benefactor, by which only he is now known. He died in 1662.

**POUT**, *n. s.* From *pouth*. A kind of fish; a cod-fish; also a kind of bird, or heath fowl.

Of wild birds, Cornwall hath quail, wood-dove, heath-cock, and *pout*. *Carew's Survey of Cornwall.*

**POUR**, *v. n.* Sax. botan. Fr. *bouter*. To look sullen; push out the lips.

Like a misbehaved and sullen wench,  
Thou *pout'st* upon thy fortune and thy love.

*Shakespeare.*

Satyrus was made up betwixt man and goat, with a human head, hooked nose, and *putting* lips.

I would advise my gentle readers, as they consult the good of their faces, to forbear *stomping* upon loyalists, and *putting* at the government.

*Addison's Freeholder.*

The nurse remained *putting*, nor would she touch a bit during the whole dinner.

*Arbutnot and Pope.*

The ends of the wounds must come over one another, with a compress to press the lips equally down, which would otherwise become crude, and *pout* out with great lips. *Wiseman.*

**POWDER**, *n. s., v. a., v. n.* French *powdre*; Ital. *pulvere*; Lat. *pulvis*. Dust; any body comminuted; particularly powder prepared for the hair, and gunpowder: to powder is to reduce to dust; to sprinkle as with dust: the compounds are explained by the extracts.

The calf which they had made, he burnt in the fire, and ground it to *powder*. *Exodus xxxii. 20.*

If you embowel me to-day, I'll give you leave to *powder* me and eat me to-morrow. *Shakespeare.*

To the Spital go,  
And from the *powderring-tub* of infamy  
Fetch forth the *lazar kite* Doll Tearsheet. *Id.*

Salting of oysters, and *powderring* of meat, keeps them from putrefaction. *Bacon's Nat. History.*

The seditious, being furnished with artillery *powder* and shot, battered Bishopsgate. *Huyward.*

*Powder* thy radiant hair,  
Which if without such ashes thou would'st wear,  
Thou who, to all which come to look upon,  
Wert meant for Phœbus, would'st be Phaeton.

*Dunne.*

When the hair is sweet through pride or lust,  
The powder doth forget the dust. *Herbert.*

Immoderate feeding upon powdered beef, pickled  
meats, anchovy, and debauching with brandy, do in-  
crease and accuate the blood.

*Harvey on Consumption.*

My hair I never powder, but my chief  
Invention is to get me powdered beef.

*Cleveland.*

In the galaxy, that milky way

Which nightly, as a circling zone, thou seest

Powdered with stars. *Milton's Paradise Lost.*

The flame invades the powder-rooms, and then  
Their guns shoot bullets, and their vessels men.

*Waller.*

When we view those large bodies of oxen, what  
can we better conceit them to be, than so many  
living and walking powdering-tubs, and that they  
have animam salis? *More.*

Whilst two companions were disputing it at  
word's point, down comes a kite powdering upon  
them and gobbets up both. *L'Esrange.*

As to the taking of a town, there were few con-  
querors could signalise themselves that way, before  
the invention of powder and fortifications. *Addison.*

A brown powdery spar, which holds iron, is found  
amongst the iron ore. *Woodward on Fossils.*

The powdered footman

Beneath his flapping hat secures his hair.

*Gay.*

There stands the toilette,

The patch, the powder-box, pulville, perfumes.

*Id.*

Upon the blowing up of a powdermill, the win-  
dows of adjacent houses are bent and blown out-  
wards, by the elastick force of the air within exerting  
itself. *Arbuthnot.*

Our humbler province is to tend the fair,

To save the powder from too rude a gale. *Pope.*

You may stick your candle in a bottle or a pow-  
der-horn. *Swift.*

**POWDER CHESTS**, in the marine, wooden trian-  
gular chests, filled with gunpowder, nails, and  
old iron, to set on fire when a vessel is boarded  
by an enemy. These cases are usually from  
twelve to eighteen inches in length, and about  
eight or ten in breadth, having their outer or up-  
per part terminating in an edge. They are nailed  
to several places of the quarter-deck and bulk-  
head of the waist, having a train of powder which  
communicates with the inner apartments of the  
ship, so as to be fired at pleasure to annoy the  
enemy. They are particularly used in merchant-  
ships which are furnished with close-quarters to  
oppose the boarders.

**POWDERS, FULMINATING**, in chemistry, are  
compositions which explode upon the applica-  
tion either of certain degrees of heat, trituration,  
or concussion. Under this title, therefore, are  
included several very distinct chemical combi-  
nations, the principal of which are those of  
azote, with the metals and alkalis. The common  
fulminating powder is thus made:—Triturate  
in a warm mortar three parts by weight of  
nitre, two of carbonate of potass, and one of  
flowers of sulphur. A few grains of this laid  
upon a knife, and held over the candle, first fuse,  
and then explode with a loud report. A drachm  
of it put into a shovel, and held over the fire,  
makes a noise as loud as a cannon, and indents  
the shovel as if it had received a violent blow.  
If the mass be removed from the fire as soon as

Vol. XVIII.

it is fused, and kept in a dry, well closed phial, it  
may at any time be exploded by a spark, and will  
burn like gunpowder, but more rapidly and with a  
greater report; but this effect will not be pro-  
duced by unmelted powder. Whilst the powder  
is in fusion, but not sufficiently heated to pro-  
duce the blue flame, a particle of ignited char-  
coal thrown upon it will immediately occasion  
a very loud explosion. The fulminating property  
of this powder is acquired by fusion, or when  
the potass and sulphur form sulphuret of potass.  
It may therefore be prepared by mixing sulphu-  
ret of potass with nitre, instead of adding the  
sulphur and alkali separate. If a solution of  
gold be precipitated by ammonia, the product  
will be fulminating gold. This precipitate,  
when separated by filtration, and washed, must  
be dried without heat, as it is liable to explode  
with no great increase of temperature; and it  
must not be put into a bottle closed with a glass  
stopper, as the friction of this would expose the  
operator to the same danger. Less than a grain  
of this, held over the flame of a candle, explodes  
with a very sharp and loud noise.

Fulminating silver may be made by precipi-  
tating a solution of nitrate of silver by lime-wa-  
ter, drying the precipitate by exposure to the air  
for two or three days, and pouring on it liquid  
ammonia. When it is thus converted into a  
black powder, the liquid must be poured off, and  
the powder left to dry in the air. It detonates  
with the gentlest heat, or even with the slightest  
friction, so that it must not be removed from the  
vessel in which it is made. If a drop of water  
fall upon it, the percussion will cause it to ex-  
plode. It was discovered by Berthollet.

Brugnatelli made a fulminating silver by pow-  
dering a hundred grains of nitre of silver, put-  
ting the powder into a beer-glass, and pouring  
on it, first an ounce of alcohol, then as much  
concentrated nitrous acid. The mixture grows  
hot, boils, and an ether is visibly formed, that  
changes into gas. By degrees the liquor becomes  
milky and opaque, and is filled with small white  
clouds. When all the gray powder has taken  
this form, and the liquor has acquired a consist-  
ency, distilled water must be added immediately  
to suspend the ebullition, and prevent the matter  
from being redissolved, and becoming a mere  
solution of silver. The white precipitate is then  
to be collected on a filter, and dried. The force  
of this powder greatly exceeds that of fulminat-  
ing mercury. It detonates in a tremendous  
manner, on being scarcely touched with a glass  
tube, the extremity of which has been dipped in  
concentrated sulphuric acid. A single grain,  
placed on a lighted coal, makes a deafening  
report. The same thing happens if it be placed  
on a bit of paper on an electric pile, and a spark  
drawn from it.

M. Chenevix has invented a fulminating silver  
not so dangerous as that just mentioned. It ex-  
plodes only by a slight friction in contact with  
combustible bodies. It is thus prepared:—Dis-  
fuse a quantity of alumina through water, and  
let a current of oxygenated muriatic acid gas  
pass through it for some time. Then digest some  
phosphate of silver on the solution of the oxyge-  
nated muriate of alumina, and evaporate

C

slowly. The product obtained will be a hyper-oxygenated muriate of silver, a single grain of which, in contact with two or three of sulphur, will explode violently with the slightest friction.

Fulminating mercury was discovered by Mr. Howard. A hundred grains are to be dissolved with heat in an ounce and a half by measure of nitric acid. The solution, when cold, is to be poured on two ounce measures of alcohol, and heat applied till an effervescence is excited. As soon as the precipitate is thrown down, it must be collected on a filter, that the acid may not react on it, and washed and dried by a very gentle heat. It detonates with a very little heat or friction.

Of some experiments on the powers of this powder, the inventor gives the following account:— 'Desirous of comparing the strength of the mercurial compound with that of gunpowder,' says Mr. Howard, 'I made the following experiment in the presence of my friend Mr. Abernethy:— Finding that the powder could be fired by flint and steel, without a disagreeable noise, a common gunpowder proof, capable of containing eleven grains of fine gunpowder, was filled with it, and fired in the usual way: the report was sharp, but not loud. The person who held the instrument in his hand felt no recoil: but the explosion laid open the upper part of the barrel, nearly from the touch-hole to the muzzle, and struck off the hand of the register, the surface of which was evenly indented to the depth of 0.1 of an inch, as if it had received the impression of a punch.

'The instrument used in this experiment being familiarly known, it is therefore scarcely necessary to describe it; suffice it to say that it was of brass, mounted with a spring register, the moveable hand of which closed up the muzzle, to receive and graduate the violence of the explosion. The barrel was half an inch in calibre, and nearly half an inch thick, except where a spring of the lock impaired half its thickness.

'A gun belonging to Mr. Keir, an ingenious artist of Camden Town, was next charged with seventeen grains of the mercurial powder, and a leaden bullet. A block of wood was placed at about eight yards from the muzzle to receive the ball, and the gun was fired by a fuse. No recoil seemed to have taken place, as the barrel was not moved from its position, although it was in no ways confined. The report was feeble: the bullet, Mr. Keir conceived, from the impression made on the wood, had been projected with about half the force it would have been by an ordinary charge, or sixty-eight grains of the best gunpowder. We therefore re-charged the gun with thirty-four grains of the mercurial powder; and, as the great strength of the piece removed any apprehension of danger, Mr. Keir fired it from his shoulder, aiming at the same block of wood. The report was like the first, sharp, but not louder than might have been expected from a charge of gunpowder. Fortunately Mr. Keir was not hurt; but the gun was burst in an extraordinary manner. The breech was what is called a patent one, of the best forged iron, consisting of a chamber 0.4 of an inch thick all round, and 0.4 of an inch in calibre; it was torn open and flamed in many directions, and the gold touch-hole driven out. The barrel into

which the breech was screwed was 0.5 of an inch thick; it was split by a single crack three inches long, but this did not appear to me to be the immediate effect of the explosion. I think the screw of the breech, being suddenly enlarged, acted as a wedge upon the barrel. The balled missed the block of wood, and struck against a wall, which had already been the receptacle of so many bullets that we could not satisfy ourselves about the impression made by this last.

'As it was pretty plain that no gun could confine a quantity of the mercurial powder sufficient to project a bullet with a greater force than an ordinary charge of gunpowder, I determined to try its comparative strength in another way. I procured two blocks of wood, very nearly of the same size and strength, and bored them with the same instrument to the same depth. The one was charged with half an ounce of the best Dartford gunpowder, and the other with half an ounce of the mercurial powder; both were alike buried in sand, and fired by a train communicating with the powders by a small touch-hole. The block containing the gunpowder was simply split into three pieces; that charged with the mercurial powder was burst in every direction, and the parts immediately contiguous to the powder were absolutely pounded, yet the whole hung together, whereas the block split by the gunpowder had its parts fairly separated. The sand surrounding the gunpowder was undoubtedly most disturbed; in short, the mercurial powder appeared to have a great superiority.

During a lecture in the laboratory of Yale College, about 100 or 150 grains of fulminating mercury lay on a stool, and were covered with a glass receiver of about five or six quarts capacity. A small quantity of the same powder, at the distance of a few feet, was merely flashed by a coal of fire, but without explosion. In a manner not easily understood, the whole powder under the glass receiver instantly exploded with a dreadful report; but, what was particularly remarkable, the glass was merely lifted up a little, and was shattered by its fall, while the stool, made of fir plank, an inch and a half thick, on which the powder lay, had a hole blown quite through it, almost as large as the palm of the hand. The whole effect of the explosion was confined to the stool, every thing around having remained uninjured.

An effect almost equally singular took place lately in the same laboratory, with some fulminating silver upon the point of a knife, which was about to be put upon a plate of copper, connected with one pole of a galvanic battery in active operation. The other pole was not touched by the experimenter, but, probably by the influence conveyed through the floor of the room, the powder exploded the moment the knife touched the plate of copper. The knife blade was broken in two, and one-half of it thrown to a distance among the audience.

Three parts of chlorate of potassa, and one of sulphur, triturated in a metal mortar, cause numerous successive detonations, like the cracks of a whip, the reports of a pistol, or the fire of musketry, according to the rapidity and force of

the pressure employed. A few grains, struck with a hammer on an anvil, explode with a noise like that of a musket, and torrents of purple heat appear round it. Thrown into concentrated sulphuric acid, it takes fire and burns with a white flame, but without noise.

Six parts of the chlorate, one of sulphur, and one of charcoal, detonate by the same means, but more strongly, and with a redder flame.

Sugar, gum, or charcoal, mixed with the chlorate, and fixed or volatile oils, alcohol, or ether, made into a paste with it, detonate very strongly by the stroke, but not by trituration. Some of them take fire, but slowly, and by degrees, in the sulphuric acid.

All those mixtures that detonate by the stroke, explode much more loudly if previously wrapped up in double paper.

Fulminations of the most violent kind require the agency of azote or nitrogen; as we see not only in its compounds with the oxides of gold, silver, and platina; but still more remarkably in its chloride and iodide.

A fulminating antimoniac powder has been prepared by M. Serullas in the following manner:—Grind carefully together 100 parts of tartar emetic and three parts of lamp-black, or ordinary charcoal powder. Crucibles capable of holding about three ounces of water, to be only three-fourths filled, are to be ground smooth on their edges, and rubbed inside with powdered charcoal, so as to dust lightly their surface, and prevent the subsequent adherence of the carbonaceous cone which remains after the calcination. The above mixture, being introduced into the crucible, is to be covered with a layer of powdered charcoal; and the joinings of the cover must be luted. After exposure for three hours to a good heat in a reverberatory furnace, the crucible must be removed, and left to cool for six or seven hours. This interval of time is necessary to allow the air, which always penetrates a little way into the crucibles, to burn the exterior coat of the fulminating mass; otherwise, if it be taken out too recently, there is always an explosion. We must then hastily enclose it, without breaking, into a glass with a wide opening. After some time, it spontaneously breaks down into fragments of different sizes, retaining all its properties for years. When the calcination has been conducted as above, the product is excessively fulminating, so that, without the least compression, it gives rise to a violent detonation on contact with water. 100 parts of antimony, seventy-five of carbureted cream of tartar, and twelve of lamp black, trituated together, form also an excellent mixture. A piece of the size of a pea of this fulminating compound introduced into a mass of gunpowder explodes it when thrown into water. It is to the presence of potassium that the above explosive property is due. Sixty parts of carbureted cream of tartar, 120 of bismuth, and one of nitre, treated as above, yield an alloy very rich in potassium, of which the smallest portion cut with scissars sparkles. When bruised it melts and burns.—*An. de. Chim.* Oct. 1822.

POWDER, JAMES'S. See JAMES'S POWDER.

POWDER MAGAZINE, a bomb-proof arched building, to contain powder in fortified places.

POWEL (David), D. D., a Welsh divine and antiquary, born in Denbighshire, about 1552, and educated at Oxford, where he graduated. He became vicar of Ruabon, in Denbighshire. He published Caradoc's History of Wales, with annotations, in 1584; and several other works. He died at Ruabon in 1590.

POWELL (Sir John), a judge of the common pleas and king's bench, was born at Gloucester, which city he represented in parliament in 1685. In 1687 he was made one of the justices of common pleas, from which he was removed to the king's bench the following year, when he distinguished himself on the trial of the seven bishops, and was in consequence deprived of office; but he was restored to it at the revolution. He was a sound lawyer, and a man of humor. An old woman being tried before him on the charge of witchcraft, among other things it was stated that she could fly. 'Prisoner,' said the judge, 'is it true that you can fly?' 'Yes, my lord.' 'Well, then, you may; for there is no law against flying;' and he directed the jury to acquit her. He died a judge in 1713.

POWER, <i>n. s.</i>	} Fr. <i>pouvoir</i> ; Span. <i>poder</i> . Command; dominion; authority; influence arising from greatness; ability; strength; motive; force: hence motion of the mind; faculty; one invested with power; host; army; divinity: powerable is an obsolete adjective for capable of performing: powerful, forcible; mighty; influential: the adverb and noun-substantive corresponding: powerless, weak; impotent.
POWER'ABLE, <i>adj.</i>	
POWER'FUL,	
POWER'FULLY, <i>adv.</i>	
POWER'FULNESS, <i>n. s.</i>	
POWER'LESS, <i>adj.</i>	

After the tribulation of those days shall the sun be darkened, and the powers of the heavens shall be shaken. *Matthew.*

Care, not fear; or fear not for themselves, altered something the countenances of the two lovers: but so as any man might perceive, was rather an assembling of powers than a dismayedness of courage. *Sidney.*

He, to work him the more mischief, sent over his brother Edward with a power of Scots and Redshanks into Ireland, where they got footing. *Spenser's State of Ireland.*

That which moveth God to work is goodness, and that which ordereth his work is wisdom, and that which perfecteth his work is power. *Hooker.*

Gazellus, upon the coming of the bassa, valiantly issued forth with all his power and gave him battle. *Knolles.*

If law, authority, and power deny not,  
It will go hard with poor Anthonio. *Shakspeare.*

If ever  
You meet in some fresh cheek the power of fancy,  
Then you shall know the wounds invisible,  
That love's keen arrows make. *Id.*

I was in the thought, they were not fairies, and yet the guiltiness of my mind, the sudden surprise of my powers, drove the grossness of the foppery into a received belief. *Id.*

Merciful powers!  
Restrain in me the cursed thoughts, that nature  
Gives way to in repose. *Id. Macbeth.*

Who leads his *power*?  
Under whose government come they along?  
*Shakespeare.*

My heart, dear Harry,  
Threw many a northward look to see his father  
Bring up his *powers*, but he did long in vain. *Id.*  
I give you welcome with a *powerless* hand,  
But with a heart full of unstained love. *Id.*  
This man had *power* with him, to draw him forth  
to his death. *Bacon's Essays.*  
He died of great years, but of strong health and  
*powers.* *Bacon.*

That you may see how *powerful* time is in altering  
tongues, I will set down the Lord's prayer, as it was  
translated in sundry ages. *Camden.*

Cast down thyself, and only strive to raise  
The glory of thy Maker's sacred name;  
Use all thy *pow'rs*, that blessed *power* to praise,  
Which gives thee *pow'r* to be and use the same.  
*Davies.*

So much he stands upon the *powerfulness* of the  
Christian religion, that he makes it beyond all the  
rules of moral philosophy, strongly effectual to ex-  
pel vice, and plant in men all kind of virtue.  
*Hateuill on Providence.*

What beast, what worm, wherein we may not see  
the footsteps of Deity? Wherein we may not read  
infiniteness of *power* and skill? *Bp. Hall.*

By understanding the true difference betwixt the  
weight and the *power*, a man may add such a fitting  
supplement to the strength of the *power*, that it shall  
move any conceivable weight, though it should never  
so much exceed that force which the *power* is natu-  
rally endowed with. *Wilkins.*

My labour  
Honest and lawful, to deserve my food  
Of those who have me in their civil *power.* *Mil on.*

We have sustained one day in doubtful fight,  
What heaven's Lord hath *powerfullest* to send  
Against us from about his throne. *Id.*  
The sun and other *powerfully* lucid bodies dazzle  
our eyes. *Boyle.*

Before the revelation of the gospel, the wickedness  
and impenitency of the heathen world was a much  
more excusable thing, because they had but very ob-  
scure apprehensions of those things which urge men  
most *powerfully* to forsake their sins. *Tillotson.*

Dejected! no, it never shall be said,  
That fate had *power* upon a Spartan soul;  
My mind on its own centre stands unmov'd  
And stable as the fabric of the world. *Dryden.*

With indignation thus he broke  
His awful silence, and the *powers* bespoke. *Id.*  
It is not in the *power* of the most enlarged under-  
standing to invent one new simple idea in the mind,  
not taken in by the ways aforementioned. *Locke.*

Observing in ourselves that we can at pleasure  
move several parts of our bodies, which were at  
rest; the effects also that natural bodies are able to  
produce in one another occurring every moment to  
our senses, we both these ways get the idea of *power.*  
*Id.*

By assuming a privilege belonging to riper years,  
to which a child must not aspire, you do but add  
new force to your example, and recommend the ac-  
tion more *powerfully.* *Id.*

If there's a *power* above us,  
And that there is all nature cries aloud  
Through all her works, he must delight in virtue.  
*Addison.*

'Tis surprising to consider with what heats these  
two *powers* have contested their title to the kingdom  
of Cyprus, that is in the hands of the Turk.  
*Id. on Italy.*

**POWER** in arithmetic and algebra, is that  
which results from the successive multiplications  
of any quantity or number into itself, the degree  
of the power being always denominated by the  
number of equal factors that are employed,  
thus:

$$\begin{aligned} 2 &= & 2^1, \text{ 1st power of } 2. \\ 2 \times 2 &= & 2^2, \text{ 2d power of } 2. \\ 2 \times 2 \times 2 &= & 2^3, \text{ 3d power of } 2. \end{aligned}$$

Hence it appears, that the index which denotes  
the degree of any power, is always equal to the  
number of factors, from which that power arises  
or one more than the number of operations.

**POWNALL** (Thomas), F.R.S. and F.S.A.  
an ingenious writer, was born at Lincoln in 1722,  
and became secretary to the commissioners for  
trade and plantations in 1745. In 1753 he went  
to America, where he prevented the formation of  
a congress in the seven years' war. For this he  
was made governor of Massachusetts, whence he  
removed to New Jersey, and next to South Car-  
olina, where he continued till 1761, when he  
was recalled, and made director-general of the  
office of control with the rank of colonel. He  
died at Bath in 1805. His works are: 1. On  
the Administration of the Colonies. 2. Descrip-  
tion of part of North America, folio. 3. Treatise  
on the study of Antiquities, 8vo. 4. Memorials  
addressed to the Sovereigns of Europe and the  
Atlantic. 5. On the Antiquities of the Provincia  
Romana of Gaul, 4to. 6. Descriptions of Ro-  
man Antiquities dug up at Bath, 4to. 7. Intel-  
lectual Physics, 4to.

**POX**, *n. s.* Sax. poccar. See **POCK**. Pro-  
perly pocks, which originally signified small  
bags or pustules; pustules; efflorescences. It  
is used of many eruptive distempers.

Wilt thou still sparkle in the box,  
Canst thou forget thy age and *pox*? *Dorset.*

**POX**, SMALL. See **MEDICINE**, Index.

**POYAIS**. A fertile tract of land on the  
Mosquito shore, near the Bay of Honduras, in  
central America, having a capital of the same  
name, and inhabited by a war-like race of In-  
dians, who have hitherto maintained their inde-  
pendence. Sir Gregor Mac Gregor, an English  
officer, who took an active part in the revolution  
of Venezuela, in 1816, seized upon Amelia  
Island in 1817, attacked Porto Bello in 1819;  
but was ultimately obliged to abandon his enter-  
prise against the Spaniards. He settled amongst  
the Poyais Indians, obtained their entire confi-  
dence, was chosen cacique, improved their com-  
merce, and established schools. The Poyais  
country yields indigo, sugar, coffee, cocoa, to-  
bacco, mahogany, dye, stuffs, &c.

**POZE**, *v. a.* To puzzle. See **POSE**.

And say you so? then I shall *poze* you quickly.  
*Shakespeare.*

**PRACHIN**, one of the sixteen circles of Bo-  
hemia, occupies the south-west corner of the  
kingdom. Its area is 1820 square miles; and  
on the borders of Bavaria it has a number of  
lofty mountains, covered with forests: the inter-  
ior is more level and fertile. The Moldau has  
its source here, but the Wottawa is the larger  
stream. In the mountains are found precious  
stones, and in the sands of the Wottawa some  
gold dust and pearls. The Bohemian is the

prevailing language. Population 210,000. The chief town is Piseck.

PRAC'TICE, *n. s.*

PRAC'TICABLE, *adj.*

PRAC'TICABLY, *adv.*

PRAC'TICABLENESS, *n. s.*

PRAC'TICAL, *adj.*

PRAC'TICALLY, *adv.*

PRAC'TICALNESS, *n. s.*

PRAC'TIC, *adj.*

PRAC'TISE, *v. a. & v. n.*

PRAC'TISANT, *n. s.*

PRAC'TISER,

PRAC'TITIONER.

Fr. *pratique*; Lat. *practica*; Gr. *πρακτικη*. Habit; custom; use; method; dexterity; performance; practicable is performable; feasible; assailable: the adverb and noun-substantive corresponding: practical and practick (the latter obsolete), relating to action; not merely speculative: the adverb and noun-substantive that follow corresponding: to practise, to do habitually or constantly: as a verb neuter, to form a habit of acting; transact; use; a profession; use bad or deceitful arts: practiser and practitioner, he who practises.

Incline not my heart to *practise* wicked works with men that work iniquity. *Psalms* cxli. 4.

Will truth return unto them that *practise* in her? *Ecclesiastes*.

He sought to have that by *practise* which he could not by prayer; and, being allowed to visit us, he used the opportunity of a fit time thus to deliver us. *Sidney*.

Thereto his subtle engines he doth bend,  
His *practick* wit, and his fair filed tongue,  
With thousand other sleights. *Spenser*.

There are some papistical *practitioners* among you. *Whitgift*.

This disease is beyond my *practise*; yet I have known those which have walked in their sleep, who have died holily in their beds. *Shakspeare*.

Shall we thus permit  
A blasting and a scandalous breath to fall  
On him so near us? this needs must be *practise*;  
Who knew of your intent and coming hither? *Id.*

When he speaks,  
The air, a chartered libertine, is still;  
And the mute wonder lurketh in men's ears,  
To steal his sweet and honied sentences;  
So that the act and *practick* part of life  
Must be the mistress to this theoric. *Id.*  
If thou do'st him any slight disgrace, he will *practise*  
against thee by poison. *Id. As You Like It.*  
Here entered Pucelle and her *practisants*. *Shakspeare*.

Sweet *practiser*, thy physick I will try,  
That ministers thine own death if I die. *Id.*

Wise states prevent purposes  
Before they come to *practise*, and foul *practices*  
Before they grow to act. *Denham's Sophy*.

True piety without cessation tost  
By theories the *practick* part is lost. *Denham*.  
At *practised* distances to cringe, not fight. *Milton*.

They shall *practise* how to live secure. *Id.*  
Oft have we wondered

How such a ruling spirit you could restrain,  
And *practise* first over yourself to reign. *Waller*.  
Religion comprehends the knowledge of its principles, and a suitable life and *practise*; the first, being speculative, may be called knowledge; and the latter, because it is *practicable*, wisdom. *Tillotson*.  
I never thought I should try a new experiment, being little inclined to *practise* upon others, and as little that others should *practise* upon me. *Temple's Miscellanies*.

I had reasoned myself into an opinion that the

use of physicians, unless in some acute disease, was a venture, and that their greatest *practisers* *practis'd* least upon themselves. *Temple*.

An heroic poem should be more like a glass of nature, figuring a more *practicable* virtue to us, than was done by the ancients. *Dryden*.

Obsolete words may be laudably revived, when they are more sounding, or more significant than those in *practise*. *Id.*

This falls out for want of examining what is *practicable* and what not, and for want again of measuring our force and capacity with our design. *L'Estrange*.

Of such a *practise* when Ulysses told,  
Shall we, cries one, permit  
This lewd romancer and his bantering wit? *Tate*.

There are two functions of the soul, contemplation and *practise*, according to that general division of objects, some of which only entertain our speculations, others also employ our actions; so the understanding, with relation to these, is divided into speculative and *practick*. *South*.

He must be first an exercised, thorough-pacc'd *practitioner* of these vices himself. *Id.*

We will, in the principles of the politician, shew how little efficacy they have to advance the *practiser* of them to the things they aspire to. *Id.*

Few *practical* errors in the world are embraced upon the stock of conviction, but inclination. *Id.*

Whilst they contend for speculative truth, they, by mutual calumnies, forfeit the *practick*. *Government of the Tongue*.

I've *practis'd* with him,  
And found a means to let the victor know,  
That Shaphax and Sempronius are his friends. *Addison*.

The meanest capacity, when he sees a rule *practically* applied before his eyes, can no longer be at a loss how it is to be performed. *Rogers*.

Tooth-drawers are *practical* philosophers, that go upon a very rational hypothesis, not to cure, but to take away the part affected. *Steele*.

After one or more ulcers formed in the lungs, I never, as I remember, in the course of above forty years' *practise*, saw more than two recover. *Blackmore*.

This is a *practicable* degree of christian magnanimity. *Atterbury*.

The author exhorts all gentlemen *practitioners* to exercise themselves in the translatory. *Arbuthnot*

Others by guilty artifice and arts  
Of promised kindness *practise* on our hearts;  
With expectation blow the passion up,  
She fans the fire without one gale of hope. *Granville*.

Unreasonable it is to expect, that those who lived before the rise and condemnation of heresies, should come up to every accurate form of expression which long experience afterwards found necessary, to guard the faith, against the subtle *practices*, or provoking insults of its adversaries. *Waterland*.

Some physicians have thought, that if it were *practicable* to keep the humours of the body in an exact balance of each with its opposite, it might be immortal; but this is impossible in the *practise*. *Swift*.

I do not know a more universal and unnecessary mistake among the clergy, but especially the younger *practitioners*. *Id.*

PRACTICE, in military education, or gun-practise. In the spring, as soon as the weather permits, the exercise of the great guns begins, with an intention to show the gentlemen cadets, at the royal military academy at Woolwich, and private men, the manner of laying, loading,

pointing, and firing the guns. Sometimes instruments are used to find the centre line, or two points, one at the breach, the other at the muzzle, which are marked with chalk, and whereby the piece is directed to the target: then a quadrant is put into the mouth to give the gun the required elevation, which at first is guessed at, according to the distance the target is from the piece. When the piece has been fired, it is sponged to clear it from any dust or sparks of fire that might remain in the bore, and loaded; then the centre line is found as before; and if the shot went too high or too low, to the right or to the left, the elevation and trail are altered accordingly. This practice continues morning and evening for about six weeks, more or less, according as there are a greater or less number of recruits. In the mean time others are shown the motions of quick-firing with field-pieces. Mortar-practice is generally acquired thus: a line of 1500 or 2000 yards is measured in an open spot of ground from the place where the mortars stand, and a flag fixed at about 300 or 500 yards: this being done, the ground where the mortars are to be placed is prepared and levelled with sand, so that they may lie at an elevation of forty-five degrees; then they are loaded with a small quantity of powder at first, which is increased afterwards by an ounce every time, till they are loaded with a full charge; the times of the flights of the shells are observed to determine the length of the fuzes. The intention of this practice is when a mortar battery is raised in a siege, to know what quantity of powder is required to throw the shells into the works at a given distance, and to cut the fuzes of a just length, that the shell may burst as soon as it touches the ground.

PRADON (Nicholas), a French dramatic poet, born at Rouen in the seventeenth century. He affected to be the rival of Racine; and, through the support of a party, his tragedy of Phædra and Hippolytus appeared for some time to balance the reputation of Racine's tragedy of the same title. He died at Paris in 1698.

PRÆCOGNITA, *n. s.* Latin *præcognita*. Things previously known in order to understand something else.

Either all knowledge does not depend on certain *præcognita* or general maxims, called principles, or else these are principles. *Locke.*

PRÆMUNIRE, in law, is taken either for a writ so called, or for the offence whereon the writ is granted; the one may be understood by the other. It is named, from the first words of the writ, 'Præmunire facias, A. B.—Cause A. B. to be forewarned—that he appear before us to answer the contempt wherewith he stands charged;' which contempt is particularly recited in the preamble to the writ. It derived its origin from the exorbitant power claimed and exercised in England by the pope; and was originally ranked as an offence immediately against the king; because it consisted in introducing a foreign power into this land, and creating imperium in imperio, by paying that obedience to papal process which constitutionally belonged to the king alone, long before the Reformation in the reign of Henry VIII. The church of

Rome, under pretence of her supremacy and the dignity of St. Peter's chair, took on her to bestow most of the ecclesiastical livings of any worth in England, by mandates, before they were void. These provisions were so common that at last Edward I., in the thirty-fifth year of his reign, made a statute against papal provisions, which, Coke says, is the foundation of all the subsequent statutes of præmunire. In the reign of Edward II. the pope again endeavoured to encroach, but the parliament withstood him; and it was one of the articles charged against that unfortunate prince that he had given allowance to the pope's bulls. But Edward III. to remedy these grievances, in conjunction with his nobility, wrote an expostulatory letter to the pope; but receiving a menacing answer, acquainting him that the emperor and the king of France had lately submitted to the holy see, Edward replied, that if both the emperor and the French king should undertake the pope's cause, he was ready to give battle to them both, in defence of the liberties of the crown. Hereupon more sharp and penal laws were devised against provisors, which enact, that the court of Rome shall present or collate to no bishopric or living in England; and that whoever disturbs any patron in the presentation to a living by virtue of a papal provision, such provisor shall pay fine and ransom to the king, and be imprisoned till he renounces such provision; and the same punishment is inflicted on such as cite the king, or any of his subjects, to answer in the court of Rome. And, when pope Urban V. attempted to revive the vassalage and annual rent to which king John had subjected his kingdom, it was unanimously agreed by all the estates, 40 Edw. III., that king John's donation was null and void, being without the concurrence of parliament, and contrary to his coronation oath; and all the nobility and commons engaged that, if the pope should endeavour to maintain these usurpations, they would resist him with all their power. In the reign of Richard II. it was found necessary to strengthen these laws; and therefore it was enacted by statutes 3 Ric. II. c. 3, and 7 c. 12, that no alien shall be capable of letting his benefice to farm; or of being presented to any ecclesiastical preferment, under the penalty of the statutes of provisors. By stat. 12 Ric. II. c. 15, all liegemen of the king accepting of a living by any foreign provision are put out of the king's protection, and the benefice made void. To which the statute 13 Ric. II. st. 2, c. 2, adds banishment, and forfeiture of lands and goods: and, by c. 3, any person bringing over any citation or excommunication from beyond sea, on account of the execution of the foregoing statutes of provisors, shall be imprisoned, forfeit his goods and lands, and suffer pain of life and member. The next statute, which is referred to by all subsequent statutes, is called the statute of præmunire. It is the statute 16 Ric. II. c. 5, which enacts that whoever procures, at Rome or elsewhere, any translations, processes, excommunications, bulls, instruments, or other things which touch the king, against him, his crown and realm, and all persons aiding and assisting therein, shall be put out of the king's protection, and their lands and

goods forfeited to the king's use, and they shall be attached by their bodies to answer to the king and his council; or process of præmunire facias shall be made out against them, as in other cases of provisors. By stat. 2 Henry IV. c. 3, all persons who accept any provision from the pope, to be exempt from canonical obedience to their proper ordinary, are also subjected to the penalties of præmunire. In the reign of Henry VIII. the penalties of præmunire were extended to more equal abuses; as the kingdom then entirely denounced the authority of the see of Rome. And therefore, by the several statutes of 24 Hen. VIII. c. 12, and 25 Hen. VIII. c. 19 and 21, to appeal to Rome from any of the king's courts, to sue to Rome for any license or dispensation, or to obey any process from thence, are made liable to the pains of præmunire. To restore to the king the nomination of vacant bishoprics, and yet keep up the established forms, it is enacted by stat. 25 Henry VIII. c. 20, that if the dean and chapter refuse to elect the person named by the king, or any archbishop or bishop to confirm or consecrate him, they shall fall within the penalties of the statutes of præmunire. By stat. 5 Eliz. c. 1, to refuse the oath of supremacy will incur the penalties of præmunire; and to defend the pope's jurisdiction in this realm is a præmunire for the first offence, and high treason for the second. By stat. 13 Eliz. c. 2, to import any agni Dei, crosses, beads, or other superstitious things pretended to be hallowed by the bishop of Rome, and tender the same to be used; or to receive the same with such intent, and not discover the offender; or if a justice of the peace, knowing thereof, shall not within fourteen days declare it to a privy counsellor, they all incur a præmunire. But importing or selling mass books, or other popish books, is by stat. 3 Jac. I. c. 5, sec. 25, only liable to a penalty of 40s. Lastly, to contribute to the maintenance of a Jesuit's college, or any popish seminary beyond sea, or any person in the same, or to contribute to the maintenance of any Jesuit or Popish priest in England, is by stat. 27 Eliz. c. 2, made liable to the penalties of præmunire. Thus far the penalties of præmunire kept within the bounds of their original institution, depressing the power of the pope; but they have since been extended to other heinous offences. Thus 1. By the stat. 1 and 2 Ph. & M. c. 8, to molest the possessors of abbey lands granted by parliament to Henry VIII. and Edward VI. is a præmunire. 2. So likewise is the offence of acting as a broker or agent in any usurious contract, where above ten per cent. interest is taken, by stat. 13 Eliz. c. 10. 3. To obtain any stay of proceedings, other than by arrest of judgment or writ of error, in any suit for a monopoly, is likewise a præmunire, by stat. 21 Jac. I. c. 3. 4. To obtain an exclusive patent for the sole making or importation of gun-powder or arms, or to hinder others from importing them, is also a præmunire, by statutes 16 Car. I. c. 21, and 1 Jac. II. c. 8. 5. To assert, maliciously and advisedly, by speaking or writing, that parliament has a legislative authority without the king, is declared a præmunire by stat. 13 Car. II. c. 1. 7. By the *habeas corpus* act, also, 31 Car. II. c. 2, it is a

præmunire, and incapable of the king's pardon, to send any subject of this realm a prisoner into parts beyond the seas. 8. By stat. 1 W. & M. stat. 1, c. 8, persons of eighteen years of age, refusing to take the oaths of allegiance and supremacy, upon tender by a magistrate, are subject to the penalties of a præmunire; and by stat. 8 and 9 W. III. c. 24, serjeants, counsellors, proctors, attorneys, and all officers of courts, practising without having taken these oaths, and subscribed the declaration against popery, are guilty of a præmunire, whether the oaths be tendered or not. 2. By stat. 6 Ann. c. 7, to assert maliciously and directly, by preaching, teaching, or advised speaking, that the then pretended prince of Wales, or any person other than according to the acts of settlement and union, has any right to the throne of these kingdoms, or that the king and parliament cannot make laws to limit the descent of the crown; such preaching, teaching, or advised speaking, is a præmunire: as writing, printing, or publishing the same doctrines, amounted to high treason. 10. By stat. 6 Ann. c. 23, if the assembly of peers of Scotland, convened to elect their ten representatives in the British parliament, shall presume to treat of any other matter save only the election, they incur the penalties of a præmunire. 11. The stat. 6 Geo. I. c. 18 (enacted after the infamous South Sea project), makes all unwarrantable undertakings by unlawful subscriptions, then commonly known by the name of bubbles, subject to the penalties of præmunire. 12. The stat. 12 Geo. III. c. 11, subjects to the penalties of præmunire all such as knowingly and wilfully solemnise, assist, or are present at, any forbidden marriage of such of the descendants of the body of king George II. as are by that act prohibited to contract matrimony without the consent of the crown. The punishment of præmunire may be gathered from the foregoing statutes, which are thus summed up by Coke: 'That, from the conviction, the defendant shall be out of the king's protection, and his lands and tenements, goods and chattels, forfeited to the king; his body shall remain in prison at the king's pleasure or during life. These forfeitures do not bring this offence within felony; being inflicted by particular statutes, and not by the common law.' But so odious, Sir Edward Coke adds, was this offence of præmunire, that a man that was attainted of it might have been slain by any other man without danger of law; but this was soon held untenable, and explained that it is only lawful to kill him in the heat of battle, or for necessary self-defence. And, to obviate such savage notions, the stat. 5 Eliz. c. 1, expressly provides that it shall not be lawful to kill any person attainted in a præmunire. But still such delinquent, though protected as a part of the public from public wrongs, can bring no action for any private injury, how atrocious soever; being so far out of the protection of the law that it will not guard his civil rights, nor remedy any grievance which he as an individual may suffer. And no man, knowing him to be guilty, can with safety give him comfort, aid, or relief.

PRÆNESTE, in ancient geography, a town of Latium, south-east of Rome, towards the terri-



tory of the Æqui; a place of great strength; famous for the temple and oracle of Fortune, called *Sortes Prænestinæ*, which Tiberius wished to destroy, but was deterred by the majestic appearance of the place. From a colony it was afterwards raised to a municipium by Tiberius, on his recovery from a dangerous illness near it. It was a very ancient city, with a territory of large extent. The temple of Fortune was built in the most sumptuous manner by Sylla, and the pavement was Mosaic work. Concerning the *Sortes*, Cicero himself says that it was a mere contrivance to deceive, either for gain or superstition.

**PRÆNOMEN**, among the ancient Romans, signified the name prefixed to the family name, answering to our Christian name: such as Caius, Lucius, Marcus, Quintus, &c.

**PRÆTEXTA TOGA**, among the ancient Romans, a long white gown, with a border of purple round the edges, and worn by the children of patricians till the age of puberty, viz. by the boys till seventeen, when they changed it for the *toga virilis*: and by the girls till marriage. It was the habit which the magistrates, augurs, and priests, as well as senators, assumed on all solemn occasions, and therefore, being looked upon as sacred, it is supposed to have been chosen for youth at that age to guard them in a peculiar manner against the temptations incident to that period of life.

**PRÆTENTATÆ**, a name given to tragedies among the Romans, in which the actors personated people of quality who had the particular privilege of wearing the *prætexta*.

**PRÆTEXTATUS**, one clothed in the *prætexta*, applied in a particular manner to the noble youth by whom it was worn to denote their age and condition, as may be learned from different medals.

**PRÆTIUM SEPULCHRI**, in old law books, &c., those goods accruing to the church wherein a corpse is buried.

**PRÆTOR**, a magistrate among the ancient Romans, not unlike our lord chief justices; as being vested with the power of distributing justice among the citizens. At first there was only one prætor; but afterwards, another being created, the first or chief one had the title of prætor urbanus, or the city prætor; the other was called peregrinus, as being judge in all matters relating to foreigners. But, besides these, there were afterwards created many provincial prætors; who were not only judges, but also assisted the consuls in the government of the provinces, and even were invested with the government of provinces themselves.

**PRÆTORIA AUGUSTA**, a town of Italy, belonging to the Salassii, near the two gates or defiles of the Alps, the *Grajæ* and *Peninæ*; a Roman colony, settled by Augustus after the defeat of the Salassii by Terentius Varro, on the spot where he encamped, situated on the river *Duria Major*. It is now called *Aosta*.

**PRÆTORIAN CAMP**, the place designed for the purpose of assembling within the same enclosure all the troops subjected to the power of the prætors. Sejanus, minister of Tiberius, occupying the station of præfect, desired that all

the soldiers of the prætorian cohorts, whose quarters were dispersed about, should be gathered together and lodged in one vast edifice, which he caused to be built, and entitled *castrum prætorium* or rather *castra prætoriana*. Antiquarians are not agreed as to the precise situation of this magnificent structure, but it is pretty evident that it stood at the eastern side of Rome, between the *Nomentane* and *Tibertine ways*, behind the baths of Dioclesian, and near the walls of the city. This camp or rather barrack was constructed of brick, of reticular workmanship, covered with stucco, and enriched with superb porticoes in columns. Constantine demolished it: but it appears to have been restored by the care of Ligorio. In the centre of the camp was the prætorium or tribunal, at which the præfect distributed justice. This had the exterior form of a temple, but was very plain within, the most conspicuous object being a table covered with a purple cloth embroidered with gold.

The camp was surrounded by an enclosure in some places double, and more or less extensive, within which were erected, on a quadrangular plan, two stories in height, the quarters of the soldiers, between the different divisions of which vast colonnades established an easy communication. The towers placed on the outside gave to the whole the appearance of a fortress, and the great space withinside ensured health to the troops, while it afforded them the requisite room for going through their various exercises.

**PRÆTORIAN GUARDS**, in Roman antiquity, were the emperor's guards, who at length were increased to 10,000: they had this denomination, according to some, from their being stationed at a place called *Prætorium*: their commander was styled *præfectus prætorii*.

**PRÆTORIUM**, or **PRETORIUM**, among the Romans, denoted the hall or court wherein the prætor lived, and wherein he administered justice. It likewise denoted the tent of the Roman general, wherein councils of war, &c., were held: also a place in Rome where the prætorian guards were lodged.

**PRÆTORIUM**, in ancient geography, a town of South Britain, belonging to the Brigantes; now called *Patrington*, according to Camden, near the mouth of the *Humber* in Yorkshire.

**PRÆTUTIANI**, an ancient people of Italy, who inhabited that part of Picenum which was anciently called *Interamna*, from its lying between two rivers, and is now named *Teramo*.

**PRAGA**, a town of Poland, on the *Vistula*, opposite *Warsaw*, with which it communicates by a bridge of boats. It has never recovered the catastrophe of 1794, when it was taken by storm, by the Russians under *Suwarrow*, and a general massacre ensued. The town was on this memorable occasion set on fire in several places, and almost reduced to ashes. The number of lives lost has been calculated at 20,000.

**PRAGMATICAL**, *adj.* } Fr. *pragmatique*,  
**PRAGMATIC**. } Græc. *πραγματις*.  
 Meddling; impertinently busy.

No sham so gross, but it will pass upon a weak man that is *pragmatical* and inquisitive.

*L'Étrange.*

Common estimation puts an ill character upon pragmatic meddling people.

*Government of the Tongue.*

Lacques were never so saucy and pragmatical as they are now-a-days. *Addison's Spectator.*

He understands no more of his own affairs than a child; he has got a sort of a pragmatical silly jade of a wife, that pretends to take him out of my hands. *Arbutnot.*

Such a backwardness there was among good men to engage with an usurping people, and pragmatical and ambitious orators. *Swift.*

**PRAGMATIC SANCTION**, in the civil law, is defined by Hottoman to be a rescript or answer of the sovereign, delivered by advice of his council, to some college, order, or body of people. A similar answer given to any particular person is called simply rescript. The term pragmatic sanction is chiefly applied to a settlement of Charles VI. emperor of Germany, who in 1722, having no sons, settled his hereditary dominions on his eldest daughter the archduchess Maria Theresa, which was confirmed by the diet of the empire, and guaranteed by Great Britain, France, the States General, and most of the powers in Europe. The word pragmatic is derived from the Greek *πραγμα*, negotium, business.

**PRAGUE**, an important city of Europe, the capital of Bohemia, is situated on both sides of the Moldau, at about an equal distance from the east and west frontiers of that kingdom; but it occupies a larger space of ground on the right than on the left bank of the river. The streets are well paved, with raised footpaths, and the town contains several squares. It is divided into the Old Town, extending in an oblong form along the right bank of the Moldau; the New Town outside of the old, and consequently farther from the river; and lastly, the Radschin or Hradschin, a detached quarter, built on a high precipitous hill, on the left bank. The whole is surrounded by a moat and earthen mound, the circuit of which is not less than ten miles. The Old Town has in one part a separate quarter for the Jews. The Radschin contains a number of houses belonging to the nobility and gentry, the cathedral, and the archbishop's palace. In a low track, to the north and east of this, is the quarter called Klein-seite, or Little Prague, said to be the oldest part of the town; and on the river side the suburb called Smichow. The Moldau is here of great width, but too shallow to be navigable. Its course is from north to south, and it is crossed by a bridge of sixteen arches, and 1850 feet in length.

Prague contains the ruins of what was the residence of the sovereign of Bohemia before the re-occupation with the Austrian dominions. This building stood at the southern extremity of the town, in the citadel, which is still well fortified. At the other end of the town, a building, also called a palace, used for public offices. It is so large as to contain 150 rooms, with a noble hall. The cathedral is a fine Gothic structure, situated on the steep side of the hill of the Radschin, overlooking a great part of the city. It suffered greatly in the thirty years' war. The theatre is large; and the churches, convents,

schools, family mansions, &c., are, though great in number, little distinguished as edifices. The houses are built in general of stone. Prague is the rendezvous of the families of the Austrian nobility and gentry, whose incomes exempt them from the necessity of living in retirement, without enabling them to figure among the grandees of the imperial court. The society is consequently genteel, and balls, theatrical exhibitions, and masquerades, are of frequent occurrence. Of the population, about 85,000, nearly 7000 are Jews, and about 5000 strangers, attracted hither by the pleasures or advantages of the place. The Protestants have here two churches: the great majority being Catholics; and Prague is the see of an archbishop. The favorite saint is John Nepomuck (Nepomucenus), who lived in the fourteenth century, and allowed himself to be cast into the Moldau, rather than reveal to the emperor an important secret.

The university is the oldest in Germany, having been founded in 1348. About forty years after the well known John Huss and Jerome of Prague appeared, and the spirit of free enquiry, aided by an intercourse with England, has never since been wholly extinct. The interference of the Bohemian government with the new sectaries caused a reduction of the number of pupils at the university, and in 1409 that of Leipsic was founded by a body of them removing. The present number of the professors at Prague is about forty; that of students 900. It has classes of theology, law, medicine, philosophy, and classics. The public library contains above 100,000 volumes. Here is also an observatory, a cabinet of natural history, a seminary for training schoolmasters, three gymnasia, an academy for drawing and painting, riding and fencing schools, and a number of private boarding houses. To these may be added the academy of sciences, the societies of economics and of the friends of the arts. There are likewise some good private galleries of paintings. Tycho Brahe was a refugee in this city; the site of his observatory is now occupied by a mansion of a nobleman. Of the charitable institutions, the principal are three hospitals, two orphan-houses, and a lying-in-hospital.

The manufactures in linen, cotton, silk, and hats, are extensive; there are also, on a smaller scale, those of paper, brass-ware, tinkery, plated goods, glass, tobacco (on the government account), mathematical and musical instruments. Here is also some transit trade, and brewing is carried on extensively. Of the mercantile houses, nearly the half are Jewish. The shops are in general ill furnished, and the lower orders in wretched poverty.

Prague has often been exposed to the calamities of war, particularly in the fifteenth century, by the persecution of the Hussites. In 1620 a battle was fought on the White Mountain, about two miles from this city, between the Imperialists and Bohemians, in which the latter were defeated, and compelled to relinquish their sovereign. In 1741 a French corps blockaded in Prague, and in 1757, the Austrians being defeated near this place by the Prussians, Prague underwent a siege and heavy bombardment. The

**town** would require almost an army to defend it; **for**, though fortified, it is far too extensive for strength, and is commanded by several adjacent heights. 144 miles N. N. W. of Vienna, and seventy-five S. S. E. of Dresden. Long. (of the observatory) 14° 25' 10" E., lat. 50° 5' 23" N.

**PRAISE**, *n. s.* & *v. a.* Belg. *prijis*; Swed.

**PRAISEFUL**, *adj.*

**PRAISER**, *n. s.*

**PRAISEWORTHY**, *adj.* } known; fame; commendation; honor; tribute of gratitude: to commend; to applaud; to celebrate; to glorify: praiseworthy is commendable; worthy of praise.

One generation shall praise thy works to another, and declare thy mighty works. *Palm cxlv. 4.*

The shepherds returned, glorifying and praising God for all the things that they had heard and seen. *Luke ii. 20.*

Of whose high praise, and praiseful bliss,  
Goodness the pen, heaven the paper is. *Sidney.*  
We men and praisers of men should remember, that, if we have such excellencies, it is reason to think them excellent creatures, of whom we are. *Sidney.*

The Tritonian goddess having heard  
Her blazed fame, which all the world had filled,  
Came down to prove the truth, and due reward  
For her praiseworthy workmanship to yield. *Spenser.*

Turn to God, who knows I think this true,  
And useth oft, when such a heart missays,  
To make it good; for such a praiser prays. *Donne.*

He ordain'd a lady for his prize,  
Generally praiseful, fair and young, and skilled in  
housewiferies. *Chapman's Iliad.*

Forgive me, if my verse but say you are  
A Sidney: but in that extend as far  
As loudest praisers. *Ben Jonson's Epigrams.*  
Since men have left to do praiseworthy things,  
Most think all praises flatteries; but truth brings  
That sound, and that authority with her name,  
As to be raised by her is only fame. *Ben Jonson.*  
Then is our fortitude worthy of praise, when we  
can endure to be miserable. *Bp. Hall. Contemplations.*

Will God incense his ire  
For such a petty trespass, and not praise  
Rather your dauntless virtue? *Milton.*  
They touched their golden harps, and hymning  
praised  
God and his works. *Id.*

Lucan, content with praise, may lie at ease  
In costly grots and marble palaces;  
But to poor Bassus what avails a name,  
To starve on compliments and empty fame? *Dryden.*

We praise not Hector, though his name we know  
Is great in arms; 'tis hard to praise a foe. *Id.*  
Firmus, who seized upon Egypt, was so far praiseworthy, that he encouraged trade. *Arbutn t.*

A soul redeemed demands a life of praise;  
Hence the complexion of his future days;  
Hence a demeanour holy and unspiced,  
And the world's hatred, as its sure effect. *Couper.*

**PRAM**, or **PRAME**, a kind of lighter used in Holland and the ports of the Baltic Sea, to carry the cargo of a merchant ship along-side in order to lade, or to bring it to shore to be lodged in the store-houses after being discharged out of the vessel.

**PRAME**, in military affairs, a kind of floating battery, being a flat-bottomed vessel, which draws little water, mounts several guns, and is very useful in covering the disembarkation of troops.

**PRANCE**, *v. n.* Belg. *pronken*; Dan. *prango*, to set one's self to show; to move pompously or ostentatiously; to spring and bound in high mettle.

The horses' hoofs were broken by means of the prancings, the prancings of their mighty ones. *Judges v. 22.*

Here's no fantastick mask, nor dance,  
But of our kids that frisk and prance;

Nor wars are seen,

Unless upon the green

Two harmless lambs are butting one the other. *Wotton.*

I see

The' insulting tyrant prancing o'er the field,  
Strowed with Rome's citizens, and drenched in  
slaughter,

His horses' hoofs wet with Patrician blood. *Addison.*  
With mud filled high, the rumbling cart draws  
near,

Now rule thy prancing steeds, laced charioteer. *Gay.*

We should neither have meat to eat, nor manufacture  
to clothe us, unless æm could prance about in  
coats of mail, or eat brass. *Swift.*

Far be the spirit of the chase from them,

To spring the fence, to rein the prancing steed. *Thomson.*

**PRANK**, *v. a.* & *n. s.* Belg. *pronken*. See **PRANCE**. To decorate; dress or adjust to ostentation: a frolic.

Some prank their ruffs, and others timely dight  
Their gay attire. *Spenser.*

These are tribunes of the people,  
The tongues o' the common mouth: I despise them;  
For they do prank them in authority  
Against all noble sufferance. *Shakespeare.*

Your high self,  
The gracious mark o' the land, you have obscured  
With a swain's wearing; and me, poor lowly maid,  
Most goddess-like pranked up. *Id. Winter's Tale.*  
Lay home to him;

Tell him, his pranks have been too broad to bear  
with. *Shakespeare.*

They caused the table to be covered and meat set  
on, which was no sooner set down, than in came the  
harpies, and played their accustomed pranks. *Raleigh.*

Ye gallants, whom a little yellow earth and the  
webs of that curious worm have made gorgeous  
without and perhaps proud within, remember that  
ere long, as one worm decks you without, so another  
worm shall consume you within; and that both the  
earth that you prank up, and that earth wherewith  
you prank it, is running back into dust. *Bp. Hall.*

I had not unlocked my lips  
In this unhallowed air, but that this juggler  
Would think to charm my judgment as mine eyes,  
Obtruding false rules, pranked in reason's garb. *Milton.*

They put on their clothes, and played all those  
pranks you have taken notice of. *Addison's Guardian.*

As in unequal association it always happens, what-  
ever unlucky prank was played was imputed to Cave. *Johnson.*

**PRASIUM**, in botany, shrubby hedge-nettle; a genus of the gymnospermia order and diulyna

nia class of plants; natural order forty-second, verticillata. There are four monospermous berries.

**PRASLIN**, a high island, one of the Sechelles in the Indian Seas, and next in size to Madagascar, from which it is eight leagues distant; it has a good road on the north, sheltered by the little island Curieuse. It has some French families. Long. 55° 47' E., lat. 4° 19' S.

**PRATE**, *v. n. & n. s.* } Dan. *prate*; Belg.  
**PRATTLE**, *v. n. & n. s.* } *praten*. To talk care-  
**PRATTLER**, *n. s.* } lessly; chatter; tattle;  
 be loquacious: prattle is a diminutive of prate, and as a substantive is idle, empty talk: prattler, a trifling talker.

His knowledge or skill is in *prating* too much. *Tusser.*

Behold me, which owe  
 A moiety of the throne, here standing  
 To *prate* and talk for life and honour, 'fore  
 Who please to hear. *Shakspeare. Winter's Tale.*

*I prattle*  
 Something too wildly, and my father's precepts  
 I therein do forget. *Id. Tempest.*

The bookish theorick,  
 Wherein the toged consuls can propose  
 As masterly as he; mere *prattle*, without practice,  
 Is all his soldiership. *Id. Othello.*

Poor *prattler*! how thou talkest. *Shakspeare.*  
 After flammock and the blacksmith had, by joint  
 and several *pratings*, found tokens of consent in the  
 multitude, they offered themselves to lead them.  
*Bacon's Henry VII.*

*Prattler*, no more, I say;  
 My thoughts must work, but like a noiseless sphere,  
 Harmonious peace must rock them all the day;  
 No room for *prattlers* there. *Herbert.*

Oh listen with attentive sight  
 To what my *prating* eyes indite! *Cleveland.*  
 Would her innocent *prate* could overcome me;  
 Oh! what a conflict do I feel. *Denham's Sophy.*  
 The insignificant *prattle* and endless garrulity of  
 the philosophy of the schools. *Glanville.*

What nonsense would the fool thy master *prate*,  
 When thou, his knave, canst talk at such a rate!  
*Dryden.*

A French woman teaches an English girl to  
 speak and read French, by only *prattling* to her.  
*Locke.*

There is not so much pleasure to have a child  
*prattle* agreeably, as to reason well.  
*Id. On Education.*

His tongue, his *prattling* tongue, had changed him  
 quite  
 To sooty blackness, from the purest white. *Addison.*  
 I must *prattle* on, as afore,  
 And beg your pardon, yet this half hour.  
*Prior.*

Let credulous boys and *prattling* nurses tell,  
 How, if the festival of Paul be clear,  
 Plenty from liberal horn shall strow the year.  
*Gay.*

When expectation rages in my blood,  
 Is this a time, thou *prater*? hence, begone.  
*Southern.*  
 This is the way of the world; the deaf will *prate*  
 of discords in musick. *Watts.*

When children first begin to spell,  
 And stammer out a syllable,  
 We think them tedious creatures;  
 But difficulties soon abate,  
 When birds are to be taught to *prate*,  
 And women are the teachers. *Cowper.*

**PRATINAS**, a Greek poet, contemporary with Æschylus, born at Phisus. He was the first among the Greeks who composed satires, which were represented as farces. Of these thirty-two were acted, and eighteen of his tragedies, one of which only obtained the poetical prize. Some of his verses are extant, quoted by Athenæus.

**PRATO**, a considerable and well built town of the grand duchy of Tuscany, district of Florence, Italy, is situated in a pleasant district, on the Bisenzio, and surrounded with a wall and ditch. It has several squares, of which the best is the Piazza Mercantile; but the great ornament of the place is its fine white marble cathedral. There are twelve other churches, two poor-houses, a foundling, and four other hospitals; manufactures of silk, woollen, soap, and hats. The vicinity is fertile and contains several stone quarries. Six miles south-east of Pistoja, and nine N. N. W. of Florence.

**PRATT** (Charles), earl of Camden, was the third son of Sir John Pratt, knight, chief justice of the court of king's bench under George I., and was born in 1713, the year before his father was called to the bench. He received the rudiments of his education at Eton, and afterwards removed to King's College, Cambridge. He took his degree of M. A., attended the Inner Temple, and was in due time admitted a barrister at law. Notwithstanding the great abilities he afterwards displayed, he passed nine years almost unnoticed and unnoticed, and was thinking of giving up the law and turning to divinity, when he was raised from obscurity by Mr. Henley (afterwards lord chancellor) employing him in a cause he himself was engaged in, on a circuit, and thus affording him the opportunity of displaying his professional knowledge and eloquence. He became now one of the most successful pleaders at the bar, and was chosen to represent the borough of Downton, Wilts, after the general election in 1756; appointed recorder of Bath and attorney-general in 1756; in January, 1762, he was made serjeant at law, appointed chief justice of the common pleas, and knighted. He presided in that court with a dignity and impartiality never exceeded by any of his predecessors; and, when John Wilkes was committed to the Tower on an illegal general warrant, his lordship, with the intrepidity of a British magistrate, granted him an habeas corpus; and, on his being brought before the court of common pleas, discharged him from his confinement. His spirited behaviour on this occasion, and in the consequent judicial proceedings between the printers of the North Briton and the messengers and others, was so acceptable that the city of London presented him with their freedom in a gold box, and put up his picture painted by Reynolds in the Guildhall. The corporations of Dublin, Bath, Exeter, and Norwich, paid him the like compliment. On the 16th of July, 1765, he was created a peer or Great Britain, by the title of lord Camden, baron Camden, in Kent; and July 30th 1766 on the resignation of Robert, earl of Northampton, he was appointed lord high chancellor of Great Britain. In this station he gave his most

decided opinion against the legality of general warrants. He conducted himself in this high office so as to obtain the esteem of all parties; but, when the taxation of America was in agitation, he declared himself so strongly against it, that he was obliged to resign. Upon the fall of lord North he was again taken into the administration, and on the 27th of March, 1782, appointed president of the council; an office which he resigned in March 1783. On the 13th of May 1786 he was created viscount Bayham, of Bayham abbey, Kent, and earl Camden. He died on the 18th of April, 1794, at his house in Hill Street, Berkley Square, being at that time president of the privy council, a governor of the charter-house, recorder of the city of Bath, and F. R. S. He married Elizabeth, daughter of Nicholas Jeffries, esq., by whom he had issue John Jeffries Pratt (second earl of Camden), and four daughters.

PRAATT (S. J.), a miscellaneous writer, was born at St. Ives, Hunts, in 1749, and was successively an itinerant corrector, bookseller, and author, at first using the name of Courtney Melmoth. His principal works were *The Zion of Genius*; *Sympathy*, a poem; and *Landscapes in verse*; *Liberal Opinions*, 5 vols.; *Emma Corbett*, 3 vols.; *The Pupil of Pleasure*, 2 vols.; and *Family Secrets*, 5 vols. novels: also *Gleanings abroad and in England*, 3 vols. 8vo., once very popular vols. of *Travels: The Fair Circassian*, a tragedy, &c. He died at Birmingham in 1814.

PRAVITY, *n. s.* Lat. *pravitās*. Corruption; malignity; vice.

Doubt not but that sin

Will reign among them, as of thee begot;

And therefore was law given them, to evince

Their natural *pravity*. *Milton's Paradise Lost.*

More people go to the gibbet for want of timely correction, than upon any incurable *pravity* of nature.

*L'Etrange.*

I will show how the *pravity* of the will could influence the understanding to a disbelief of Christianity.

*South.*

PRAWN, *n. s.* Italian *parnocche*. A small crustaceous fish.

I had *prawns*, and borrowed a mess of vinegar.

*Shakspeare.*

PRAWN. See **CANCER**.

PRAXAGORAS, a native of Athens, who at nineteen years of age composed the History of the Kings of Athens, in two books; and at twenty-two the Life of Constantine the Great, in which, though a Pagan, he speaks very highly of that prince. He also wrote the History of Alexander the Great. He lived under Constantine about A. D. 345.

PRAXIPHANES, a Rhodian, who wrote a learned commentary on the obscure passages of Sophocles. *Diog.*

PRAXITELES, a very celebrated Greek sculptor, who lived A. A. C. 330, in the reign of Alexander the Great. All the ancient writers mention his statues with high commendation, especially a Venus executed by him for the city of *Cnidus*, which was so admirable a piece, that king *Nicomedes* offered to release the inhabitants from their tribute as the purchase of it; but they

refused to part with it. The inhabitants of *Cos* requested him to make a statue of Venus. He gave them a choice of two, one naked, the other clothed; they preferred the latter. He was one of the gallants of Phryne.

PRAY, *v. n. & v. a.* } Fr. *prier*; Ital. *pre-*  
PRAYER, } *gare*; Lat. *precor*. To  
PRAYER-BOOK. } make petitions to a divine being; entreat; ask; supplicate; implore: prayer is petition to a divine being; mode or practice of supplicating; entreaty: prayer-book, book of devotional forms or prayers.

Therefore bretheren I beseeche you be our Lord Jesus Crist, and be charite of the hooli goost, that ghe helpe me in youre *preieris* to the Lord, that I be deluyderid from the unfaithful men that ben in iudee.

*Wiclif Romayne 15.*

And the develis *prieden* him, and seiden, if thou castist us from hennes sende us in to the drove of swyn.

*Id. Matt. 3.*

My heart's desire and *prayer* to God for Israel is, that they might be saved.

*Romans x. 1.*

Is any sick? let him call for the elders of the church, and let them *pray* over him.

*James v. 14.*

I will buy with you, sell with you, but I will not eat with you, drink with you, nor *pray* with you.

*Shakspeare.*

You shall find

A conqueror that will *pray* in aid for kindness, Where he for grace is kneeled to.

*Id.*

They did say their *prayers*, and addressed them

Again to sleep.

*Id. Macbeth.*

Were he as famous and as bold in war,

As he is famed for mildness, peace, and *prayer*.

*Shakspeare.*

Get a *prayerbook* in your hand,

And stand between two churchmen;

For on that ground I'll build a holy descent.

*Id.*  
*Pray* my colleague Antonius I may speak with him;

And as you go, call on my brother Quintus,

And *pray* him with the tribunes to come to me.

*Ben Jonson.*

The solemn worship of God and Christ is neglected in many congregations; and instead thereof, an indigested form and conception of extemporal *prayer* is used.

*White.*

He that *prays*, despairs not; but sad is the condition of him that cannot *pray*; happy are they that can, and do, and love to do it.

*Taylor.*

No man can always have the same spiritual pleasure in his *prayers*; for the greatest saints have sometimes suffered the banishment of the heart, sometimes are fervent, sometimes they feel a barrenness of devotion; for this spirit comes and goes.

*Taylor.*

Unskilful with what words to *pray*, let me Interpret for him.

*Milton.*

Sighs now breathed

Inutterable, which the spirit of *prayer*

Inspired.

*Id.*

He fell to his devotions on that behalf, and made those two excellent *prayers* which were published immediately after his death.

*Fell.*

*Prayer* among men is supposed a means to change the person to whom we *pray*; but *prayer* to God doth not change him, but fits us to receive the things *prayed* for.

*Sittingfleet.*

He praised my courage, *prayed* for my success;

He was so true a father of his country,

To thank me for defending even his foes.

*Dryden.*

He that will have the benefit of this act, must *pray* a prohibition before a sentence in the ecclesiastical court.

*Aylife.*

Should you *pray* to God for a recovery, how rash would it be to accuse God of not hearing your *prayer*, because you found your disease still to continue. *Wake.*

But I *pray*, in this mechanical formation, when the ferment was expanded to the extremities of the arteries, why did it not break the receptacle? *Bentley's Sermons.*

Barnard in spirit, sense and truth abounds; *Pray* then what wants he? fourscore thousand pounds. *Pope.*

I know not the names or number of the family which now reigns, farther than the *prayerbook* informs me. *Swift.*

If men would consider *prayer* not only as it is an invocation of God, but also as it is an exercise of holy thoughts, as it is an endeavour to feel and to be affected with the great truths of religion, they would soon see that, though God is so good as not to need much calling upon, yet that man is so weak as to need much assistance, and to be under a constant necessity of that help, and light, and improvement, which arises from *praying* much. *Law.*

Let cottagers and unenlightened swains  
Revere the laws they dream that Heaven ordains;  
Resort on Sundays to the house of *prayer*,  
And ask, and fancy they find, blessings there. *Cowper.*

PRAYA, a sea-port town, the capital of Terceira, one of the Azores; it stands in a beautiful plain, and has a church, four convents, three hospitals, and about 3000 inhabitants.

PRAYA PORTE, the capital of St. Jago, one of the Cape de Verd Isles, is the residence of the Portuguese governor general; but its trade is limited to the supply of provisions and refreshments to outward bound Guinea and East India ships. A fort commands the harbour.

PRAYER is a solemn address to God, which, when it is of any considerable length, has been said to consist of adoration, confession, supplication, intercession, and thanksgiving. By adoration we express our sense of God's infinite perfections, his power, wisdom, goodness, and mercy; and acknowledge that our constant dependence is upon Him by whom the universe was created, and has been hitherto preserved. By confession is meant our acknowledgment of our manifold transgressions of the divine laws, and our consequent unworthiness of all the good things which we enjoy at present, or expect to be conferred upon us hereafter. In supplication we intreat our omnipotent Creator and merciful Judge not to deal with us after our iniquities, but to pardon our transgressions, and by his grace to enable us to live henceforth righteously, soberly, and godly, in this present world; and by Christians this intreaty is always made in the name and through the mediation of Jesus Christ, because to them it is known that there is none other name under heaven given unto men whereby they may be saved. To these supplications for mercy, we may likewise add our prayers for the necessaries of life; because, if we seek first the kingdom of God and his righteousness, we are assured that such things shall be added unto us. Intercession signifies those petitions which we offer up for others, for friends, for enemies, for all men, especially for our lawful governors, whether supreme or subordinate. And thanksgiving is the expression of

our gratitude to God, the giver of every good and perfect gift, for all the benefits enjoyed by us and others, for the means of grace, and for the hope of glory. Such are the component parts of a regular and solemn prayer, adapted either for the church or for the closet. But an ejaculation to God, conceived on any emergency, is likewise a prayer, whether it be uttered by the voice or suffered to remain a mere affection of the mind; because the Being to whom it is addressed discerneth the thoughts of the heart. In this article we have treated of prayer in general, as the private duty of every individual; but there ought to be public as well as private prayer. The prayers of every Christian ought to be offered in the name and through the mediation of Jesus Christ. We conclude our reflections on the general duty, with observing, that nothing so forcibly restrains from ill as the remembrance of a recent address to heaven for protection and assistance. After having petitioned for power to resist temptation, there is so great an incongruity in not continuing the struggle, that we blush at the thought, and persevere, lest we lose all reverence for ourselves. After fervently devoting our souls to God, we start with horror at immediate apostasy; every act of deliberate wickedness is then complicated with hypocrisy and ingratitude; it is a mockery of the Father of Mercies, the forfeiture of that peace in which we closed our address, and a renunciation of the hope which that address inspired. But if prayer and immorality be thus incompatible, surely the former should not be neglected by those who contend that moral virtue is the summit of human perfection.

Dr. Paley has so well met the question, 'What virtue is there in prayer which should make it consistent with wisdom to grant a favor to the supplicant, which would not be consistent to grant without it?' that we shall transcribe his observations.

'1. A favor granted to prayer may be more apt, on that very account, to produce good effects upon the person obliged. It may hold in the divine bounty, what experience has raised into a proverb in the collation of human benefits, that which is obtained without asking is oftentimes received without gratitude.

'2. It may be consistent with the wisdom of the Deity to withhold his favors till they be asked for, as an expedient to encourage devotion in his rational creation, in order thereby to keep up and circulate a knowledge and sense of their dependency upon him.

'3. Prayer has a natural tendency to amend the petitioner himself, and thus to bring him within the rules which the wisdom of the Deity has prescribed to the dispensation of his favors. If these, or any other assignable suppositions, serve to remove the apparent repugnancy between the success of prayer and the character of the Deity, it is enough; for the question with the petitioner is not from which, out of many motives, God may grant his petition, or in what particular manner he is moved by the supplications of his creatures; but whether it be consistent with his nature to be moved at all, and whether there be any conceivable motives which

may dispose the divine will to grant the petition what he wants, in consequence of his praying for it.—*Moral Philosophy*, vol. 2.

PREACH, *v. n., v. a. & n. s.* } Fr. *prescher*;  
 PREACHER, *n. s.* } Latin *predico*.  
 PREACHMENT. } To deliver a public discourse upon sacred subjects; to proclaim; publish; inculcate: used by Hooker for a discourse: a preacher is one who discourses publicly on religion: preaching, a religious discourse mentioned in contempt.

Prophets *preach* of thee at Jerusalem. *Nehemiah*.  
 The Lord gave the word; great was the company of the *preachers*. *Psaln lxxviii. 11.*  
 From that time Jesus began to *preach*. *Matthew*.

The Jews of Thessalonica had knowledge that the word of God was *preached* of Paul. *Acts*.  
 This oversight occasioned the French spitefully to term religion in that sort exercised, a mere *preach*. *Hooker*.  
 There is not any thing publicly notified, but we may properly say it is *preached*. *Id.*

Was't you, that revell'd in our parliament,  
 And made a *preachment* of your high descent?  
*Shakspeare*.  
 You may hear the sound of a *preacher's* voice,  
 when you cannot distinguish what he saith. *Bacon*.

Divinity would not pass the yard and loom, the forge or anvil, nor *preaching* be taken in as an easier supplementary trade, by those that disliked the pains of their own. *Decay of Piety*.

Here lies a truly honest man,  
 One of those few that in this town  
 Honour all *preachers*; hear their own.  
*Crashaw*.  
 He decreed to commissionate messengers to *preach*  
 this covenant to all mankind. *Hammond*.

It is evident in the apostles' *preaching* at Jerusalem and elsewhere, that at the first proposal of the truth of Christ to them, and the doctrine of repentance, whole multitudes received the faith, and came in. *Hammond*.

Surely that *preaching* which comes from the soul,  
 most works on the soul. *Fuller*.  
 He oft to them *preached*  
 Conversion and repentance. *Milton*.

The shape of our cathedral is not proper for our *preaching* auditories, but rather the figure of an amphitheatre with galleries. *Graunt*.

Can they *preach* up equality of birth,  
 And tell us how we all began from earth?  
*Dryden*.  
 All this is but a *preachment* upon the text. *L'Estrange*.

No *preacher* is listened to but Time, which gives us the same train of thought that elder people have tried in vain to put into our heads before. *Swift*.

Live while you live the sacred *preacher* cries,  
 And give to God each moment as it flies.  
*Doddridge*.

PREADAMITES, a denomination given to inhabitants of the earth, conceived by some to have lived before Adam. Isaac de la Pereyra, in 1655, published a book to evince the reality of preadamites, by which he gained many proselytes; but the answer of Demarets, professor of theology at Groningen, published in 1656, put a stop to its progress; though Pereyra made a reply. His system was this: the Jews he calls

Adamites, and supposes them to have issued from Adam; and gives the title Preadamites to the Gentiles, whom he supposes to have been a long time before Adam. But, this being expressly contrary to the Mosaic account, Pereyra had recourse to the fabulous antiquities of the Egyptians and Chaldeans, and to some idle rabbins, who imagined there had been another world before that described by Moses. He was apprehended by the inquisition in Flanders; but he appealed from their sentence to Rome; whither he went in the time of Alexander VII., and where he printed a retraction. See PRE-EXISTENCE.

PREAMBLE, *n. s.* } Fr. *preambule*; Lat.  
 PREAMBULOUS, *adj.* } *preambulo*. Introduction; preface; something previous: preambulous is preparatory.

Truth as in this we do not violate, so neither is the same gainsayed or crossed, no not in those very *preambles* placed before certain readings, wherein the steps of the Latin service book have been somewhat too nearly followed. *Hooker*.

Doors shut, visits forbidden, and divers contestations with the queen, all *preambles* of ruin, though now and then he did wring out some petty contentments. *Wotton*.

This *preamble* to that history was not improper for this relation. *Clarendon*.

With *preambles* sweet  
 Of charming symphony they introduce  
 Their sacred song, and waken raptures high. *Milton*.

He not only undermineth the base of religion, but destroyeth the principal *preambulous* unto all belief, and puts upon us the remotest error from truth. *Browne*.

I will not detain you with a long *preamble*. *Dryden*.

PREAPPREHENSION, *n. s.* Pre and apprehend. An opinion formed before examination.

A conceit not to be made out by ordinary eyes, but such as regarding the clouds, behold them in shapes conformable to *preapprehensions*. *Browne*.

PREASE, *n. s.* Press; crowd. See PRESS. Obsolete.

A ship into the sacred seas,  
 New-built, now launch we; and from out our *prease*  
 Chuse two and fifty youths. *Chapman*.

PREBEND, *n. s.* } Fr. *prebende*; low Lat.  
 PREBENDARY, *n. s.* } *prebenda*. A stipend granted in cathedral churches; the stipendiary.

To lords, to principals, to *prebendaries*. *Hubbard*.

Deans and canons, or *prebends* of cathedral churches, in their first institution, were of great use, to be of counsel with the bishop. *Bacon*.

His excellency gave the doctor a *prebend* in St. Patrick's cathedral. *Swift's Miscellanies*.

A PREBEND is the maintenance a prebendary receives out of the estate of a cathedral or collegiate church. Prebends are distinguished into simple and dignitary; a simple prebend has no more than the revenue for its support; but a prebend with dignity has always a jurisdiction annexed to it.

PREBENDARY. The difference between a prebendary and a canon is, that the former receives his prebend in consideration of his obli-

**precario** in the church, but the latter merely by his being received into the cathedral or college.  
**PRECA'RIOUS, adj.** } Fr. *precaire*; Lat. *preca'riosus, adv.* } *preca'rius*. Dependent; uncertain, because depending on the will of another; held by courtesy. Dr. Johnson remarks, 'No word is more unskilfully used than this with its derivatives. It is used for uncertain in all its senses; but it only means uncertain, as dependent on others:' the adverb and noun substantive follow the senses of the adjective.

What subjects will *preca'rious* kings regard?  
 A beggar speaks too softly to be heard. *Dryden*.  
 Those who live under an arbitrary tyrannick power, have no other law but the will of their prince, and consequently no privileges but what are *preca'rius*. *Addison*.

If one society cannot meet or convene together, without the leave or licence of the other society; nor treat or enact any thing relative to their own society without the leave and authority of the other; then is that society in a manner dissolved, and subsists *preca'riously* upon the mere will and pleasure of the other. *Lesley*.

He who rejoices in the strength and beauty of youth, should consider by how *preca'rious* a tenure he holds these advantages, that a thousand accidents may before the next dawn lay all these glories in the dust. *Rogers's Sermons*.

Most consumptive people die of the discharge they spit up, which, with the *preca'riousness* of the symptoms of an oppressed diaphragm, from a mere lodgment of extravasated matter, render the operation but little advisable. *Sharp's Surgery*.

Our scene *preca'riously* subsists too long  
 On French translation and Italian song:  
 Dare to have sense yourselves; assert the stage,  
 Be justly warmed with your own native rage. *Pope*.

Heaven, earth, and hell, and worlds unknown,  
 Depend *preca'riously* on thy throne. *Watts*.

**PRECAUTION, n. s. & v. a.** Fr. *precaution*, from Lat. *precautus*. Preservative caution; preventive measures; to warn beforehand.

By the disgraces, diseases and beggary of hopeful young men brought to ruin, he may be *precautioned*. *Locke*.

Unless our ministers have strong assurances of his falling in with the grand alliance, or not opposing it, they cannot be too circumspect and speedy in taking their *precautions* against any contrary resolution. *Addison on the War*.

**PRECEDA'NEOUS, adj.** Mistaken by the author, as Dr. Johnson says, for *precidanous*; Lat. *precidanus*, cut or slain before. Previous, antecedent.

That priority of particles of simple matter, influx of the heavens and preparation of matter might be antecedent and *precidanous*, not only in order, but in time, to their ordinary productions. *Hale*.

**PRECEDE', v. a.** } Fr. *preceder*; Lat. *precedo*. To go before in order of time, place, or rank:  
**PRECE'DENCE, n. s.** }  
**PRECE'DENCY, n. s.** }  
**PRECE'DENT, adj. & n. s.** } precedence and precedence is, superiority; adjustment of place; and, in an obsolete sense, something going before or past; precedent is, former; going before; and, as a noun substantive, any thing of the same kind done before; a rule or example.

Examples for cases can but direct as *precedents* only. *Hooker*.

I do not like, but yet it does allay  
 The good *precedence*.  
*Shakspeare. Antony and Cleopatra*.

Our own *precedent* passions do instruct us  
 What levity's in youth. *Id. Timon*.

No power in Venice  
 Can alter a decree established:  
 'Twill be recorded for a *precedent*;  
 And many an error, by the same example,  
 Will rush into the state.  
*Id. Merchant of Venice*.

When you work by the imagination of another, it is necessary that he, by whom you work, have a *precedent* opinion of you, that you can do strange things. *Bacon*.

Among the laws touching *precedence* in Justinian, divers are that have not yet been so received every where by custom. *Selden*.

The royal olive accompanied him with all his court, and always gave him the *precedency*. *Hewel*.

How are we happy, still in fear of harm?  
 But harm *precedes* not sin. *Milton*.

None sure will claim in hell  
*Precedence*; none, whose portion is small  
 Of present pain, that with ambitious mind  
 Will covet more. *Id. Paradise Lost*.

The constable and marshal had cognizance touching the rights of place and *precedence*. *Hule*.

The world, or any part thereof, could not be *precedent* to the creation of man. *Id*.

God, in the administration of his justice, is not tied to *precedents*, and we cannot argue, that the providences of God towards other nations, shall be conformable to his dealings with the people of Israel. *Tillotson*.

Arius and Pelagius durst provoke  
 To what the centuries *preceding* spoke. *Dryden*.

That person hardly will be found,  
 With gracious form and equal virtue crowned;  
 Yet if another could *precedence* claim,  
 My fixt desires could find no fairer aim. *Id*.

Being distracted with different desires, the next inquiry will be, which of them has the *precedency*, in determining the will to the next action? *Locke*.

Truths, absolutely necessary to salvation, are so clearly revealed that we cannot err in them, unless we be notoriously wanting to ourselves; herein the fault of the judgment is reduced into a *precedent* default in the will. *South*.

Such *precedents* are numberless; we draw  
 Our rights from custom; custom is a law. *Granville*.

The ruin of a state is generally *preceded* by an universal degeneracy of manners and contempt of religion. *Swift*.

The contempt with which the whole army heard of the manner of your retreat assures me that, as your conduct was not justified by *precedent*, it will never be thought an example for imitation. *Junius*.

**PRECEDENCE, PRECEDENCY**, a place of honor to which a person is entitled. This is either of courtesy or of right. The former is that which is due to age, estate, &c., which is regulated by custom and civility; the latter is settled by authority, and, when broken in upon, gives an action at law. A table of *precedency* is given in our article **HERALDRY**.

**PRECENTOR, n. s.** Fr. *precentour*; Latin *precentor*. He that leads a choir.

Follow this *precentor* of ours, in blessing and magnifying that God of all grace, and never yield-



ing to those enemies, which he died to give us power to resist and overcome.

*Hammond.*

PRE'CEPT, *n. s.* Fr. *precepte*; Lat. *præ-  
PRECEP'TIAL, adj.* } *ceptum*. A rule authori-  
PRECEP'TIVE, } tatively given; a mandate;  
PRECEP'TOR, *n. s.* } direction: preceptual and  
preceptive mean, consisting of or giving pre-  
cepts: preceptor is a teacher; tutor.

The custom of lessons furnishes the very simplest and rudest sort with infallible axioms and precepts of sacred truth, delivered even in the very letter of the law of God.

*Hooker.*

Men

Can counsel, and give comfort to that grief  
Which they themselves not feel; but tasting it,  
Their counsel turns to passion, which before  
Would give preceptual medicine to rage;  
Fetter strong madness in a silken thread,  
Charm ach with air, and agony with words.

*Shakspeare.*

As the preceptive part enjoys the most exact virtue so is it most advantageously enforced by the promissory, which, in respect of the rewards, and the manner of proposing them, is adapted to the same end.

*Decay of Piety.*

A good schoolmaster minces his precepts for chil-

dren to swallow, hanging clogs on the nimbleness of his own soul, that his scholars may go along with him.

*Fuller.*

'Tis sufficient, that painting be acknowledged for an art; for it follows, that no arts are without their precepts.

*Dryden.*

Passionate chiding carries rough language with it, and the names that parents and preceptors give children, they will not be ashamed to bestow on others.

*Locke.*

The lesson given us here is preceptive to us not to do any thing but upon due consideration.

*L'Estrange.*

The ritual, the preceptive, the prophetick, and all other parts of sacred writ, were most sedulously, most religiously guarded by them.

*Government of the Tongue.*

A precept or commandment consists in, and has respect to, some moral point of doctrine, viz. such as concerns our manners, and our inward and outward good behaviour.

*Ayliffe.*

It was to thee, great Stagyrte, unknown,

And thy preceptor of divine renown.

*Blackmore.*

It is by imitation, far more than by precept, that we learn every thing; and, what we learn thus, we acquire not only more effectually, but more pleasantly.

*Burke on the Sublime.*

## PRECESSION OF THE EQUINOXES.

PRECESSION OF THE EQUINOXES. One of the most obvious and at the same time most important of the celestial motions is the diurnal revolution of the starry heavens. The whole appears to turn round an imaginary axis, which passes through two opposite points of the heavens, called the poles. One of these is in our sight, being very near the star, and in the tail of the little bear. The great circle which is equidistant from both poles divides the heavens into the north and south hemispheres, which are equal. It is called the equator, and it cuts the horizon in the east and west points, and every star in it is twelve siderial hours above, and as many below the horizon, in each revolution.

The motion of the sun determines the length of day and night, and the vicissitudes of the seasons. By a long series of observations the shepherds of Asia were able to mark out the sun's path in the heavens; he being always in the opposite point to that which comes to the meridian at midnight, with equal but opposite declination. Thus they could tell the stars among which the sun then was, although they could not see them. They discovered that his path was a great circle of the heavens, afterwards called the ecliptic; which cuts the equator in two opposite points, dividing it, and being divided by it, into two equal parts: that when the sun was in either of these points of intersection, his circle of diurnal revolution coincided with the equator, and therefore the days and nights were equal. Hence the equator came to be called the equinoctial line, and the points in which it cuts the ecliptic were called the equinoctial points, and the sun was then said to be in the equinoxes. One of these was called the vernal and the other the autumnal equinox.

It was a most important problem in practical astronomy to determine the exact moment of the sun's occupying these stations; for it was natural to compute the course of the year from that moment. Accordingly, this has been the leading problem in the astronomy of all nations. It is susceptible of considerable precision, without any apparatus of instruments. It is only necessary to observe the sun's declination on the noon of two or three days before and after the equinoctial day. On two consecutive days of this number, his declination must have changed from north to south or from south to north. If his declination on one day was observed to be 21' N., and on the next 5' S., it follows, that his declination was nothing, or that he was in the equinoctial point about twenty-three minutes after seven in the morning of the second day. Knowing the precise moments, and knowing the rate of the sun's motion in the ecliptic, it is easy to ascertain the precise point of the ecliptic in which the equator intersected it.

By a series of such observations made at Alexandria, between the years 161 and 127 before Christ, Hipparchus, the father of our astronomy, found that the point of the autumnal equinox was about 6° E. of the star called Spica virginis. Eager to determine every thing by multiplied observations, he ransacked all the Chaldean, Egyptian, and other records, to which his travels could procure him access, for observations of the same kind; but only found some observations of Aristillus and Timochares made about 150 years before. From these it appeared evident that the point of the autumnal equinox was then about 8° E. of the same star. He discusses these observations with great sagacity and rigor; and, on their authority, asserts that the

equinoctial points are not fixed in the heavens, but move to the west about  $1^\circ$  in seventy-five years or less.

This motion is called the *precession of the equinoxes*, because by it the time and place of the sun's equinoctial station precedes the usual calculations: it is fully confirmed by all subsequent observations. In 1750 the autumnal equinox was observed to be  $20^\circ 21'$  W. of spica virginis. Supposing the motion to have been uniform during this period of ages, it follows, that the annual precession is about  $50\frac{1}{2}''$ ; that is, if the celestial equator cuts the ecliptic in a particular point on any day of this year, it will on the same day of the following year cut it in a point  $50\frac{1}{2}''$  to the west of it, and the sun will come to the equinox  $20' 23''$  before he has completed his round of the heavens. Thus the equinoctial or tropical year, or true year of seasons, is so much shorter than the revolution of the sun or the sidereal year. This discovery has immortalised the name of Hipparchus. It must be acknowledged, indeed, to be one of the most singular that has been made, that the revolution of the whole heavens should not be stable, but its axis continually changing. For since the equator changes its position, and the equator is only an imaginary circle, equidistant from the two poles or extremities of the axis; these poles and this axis must equally change their positions. The equinoctial points make a complete revolution in about 25745 years, the equator being all the while inclined to the ecliptic in nearly the same angle. Therefore the poles of this diurnal revolution must describe a circle round the poles of the ecliptic, at the distance of about  $23^\circ 30'$  in 25745 years; and, in the time of Timochares, the north pole of the heavens must have been  $30^\circ$  east of where it now is.

The precession of the equinoxes, however, was known to the astronomers of India, many ages before the time of Hipparchus. The Chaldeans had also a pretty accurate knowledge of the year of seasons. From their saros, we deduce their measure of this year to be 365d. 5h. 49m. and 11s., exceeding the truth only by 26s., and much more exact than the year of Hipparchus. They had also a sidereal year of 365d. 6h. 11m. The Egyptians also had a knowledge of something equivalent to this: for they had discovered that the dog star was no longer the faithful forerunner of the overflowing of the Nile. This knowledge is also involved in the precepts of the Chinese astronomy, of much older date than the time of Hipparchus. But all these facts do not deprive Hipparchus of the honor of the discovery, or fix on him the charge of plagiarism. This motion was clearly unknown to the astronomers of the Alexandrian school, and it was pointed out to them by Hipparchus in the way in which he ascertained every other position in astronomy, namely, as the mathematical result of actual observations, and not as a thing deducible from any opinions on other subjects related to it.

As a thing for which no physical reason could be assigned, the precession of the equinoxes was long disputed. But the establishment of the Copernican system reduced it to a very clear affair; the motion, which was thought to affect

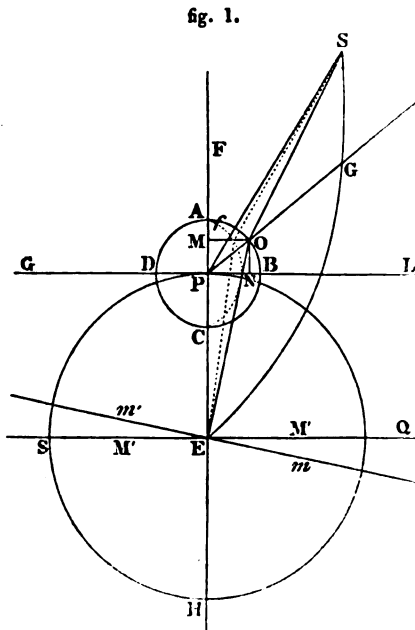
all the heavenly bodies, is now seen to be only an effect of the earth's motion. The earth turns round its own axis while it revolves round the sun, in the same manner as we may cause a child's top to spin on the brim of a mill-stone, while the stone is turning slowly round its axis. If the top spin steadily its axis will always point to the zenith of the heavens; but we frequently see that, while it spins briskly round its axis, the axis itself has a slow conical motion round the vertical line, so that, if produced, it would slowly describe a circle in the heavens round the zenith point. The flat surface of the top may represent the terrestrial equator, gradually turning itself round on all sides. If this top were formed like a ball, with an equatorial circle on it, it would represent the whole motion; the only difference being, that the spinning motion and this wavering motion are in the same direction; whereas the diurnal rotation and the motion of the equinoctial points are in contrary directions. Even this dissimilarity may be removed, by making the top turn on a cap, like the card of a mariner's compass. It is now fully established that, while the earth revolves round the sun from west to east in the plane of the ecliptic, in the course of a year it turns round its own axis from west to east in  $23\text{h. } 56' 4''$ , which axis is inclined to this plane in an angle of nearly  $23^\circ 28'$ ; and that this axis turns round a line perpendicular to the ecliptic in 25,745 years from east to west, keeping nearly the same inclination to the ecliptic.—By these means its pole in the sphere of the starry heavens describes a circle round the pole of the ecliptic at the distance of  $23^\circ 28'$  nearly. The consequence of this must be, that the terrestrial equator, when produced to the sphere of the starry heavens, will cut the ecliptic in two opposite points, through which the sun must pass when he makes the day and night equal: and that these points must shift to the west at the rate of  $5\frac{1}{2}''$  annually, which is the precession of the equinoxes. Accordingly, this has been the received doctrine among astronomers for nearly three centuries, and it was thought perfectly conformable to appearances.

Dr. Bradley hoped to discover the parallax of the earth's orbit by observations of the actual position of the pole of the celestial revolution. If the earth's axis keeps parallel to itself, its extremity must describe, in the sphere of the starry heavens, a figure equal and parallel to its orbit round the sun; and, if the stars be so near that this figure is a visible object, the pole of diurnal revolution will be in different distinguishable points of the figure. Consequently, if the axis describe this cone already mentioned, the pole will not describe a circle round the pole of the ecliptic, but will have a looped motion along this circumference, similar to the absolute motion of one of Jupiter's satellites, describing an epicycle whose centre describes the circle round the pole of the ecliptic.

This sagacious astronomer observed such an epicyclical motion, and thought that he had now overcome the only difficulty in the Copernican system; but, on considering his observations, he found this epicycle quite inconsistent with the consequences of the annual parallax, and it puzzles

zled him exceedingly. One day, while sailing on the Thames, he observed that, every time the boat tacked, the direction of the wind, estimated by the direction of the vane, seemed to change. This suggested to him the case of his observed epicycle, and he found it an optical illusion, occasioned by a combination of the motion of light with the motion of his telescope while observing the polar stars. Thus he established an incontrovertible argument for the Copernican system, and immortalised his name by his discovery of the aberration of the stars. The doctor now engaged in a series of observations for ascertaining all the phenomena of this discovery. In the course of these, which were continued for twenty-eight years, he discovered another epicyclical motion of the pole of the heavens. He found that the pole described an epicycle whose diameter was about 18", having for its centre that point of the circle round the pole of the ecliptic in which the pole would have been found independent of this new motion: and that the period of this epicyclical motion was eighteen years and seven months. It struck him that this was precisely the period of the revolution of the nodes of the moon's orbit. Of these results he gave a brief account to lord Macclesfield, then president of the Royal Society. Mr. Machin, to whom he also communicated the observations, gave him in return a very neat mathematical hypothesis, by which the motion might be calculated.

Let E (fig. 1.) be the pole of the ecliptic, and



S P Q a circle distant from it  $23^\circ 28'$ , representing the circle described by the pole of the equator during one revolution of the equinoctial points. Let P be the place of this last mentioned pole at some given time. Round P describe a circle, A B C D, whose diameter A C is  $18'$ . The real situation of the pole will be in the circumference

of this circle; and its place, in this circumference, depends on the place of the moon's ascending node. Draw EPF and GPL perpendicular to it; let GL be the colure of the equinoxes, and EF the colure of the solstices. Dr. Bradley's observations showed that the pole was in A when the node was in L, the vernal equinox. If the node recede to H, the winter solstice, the node is in B. When the node is in the autumnal equinox, at G, the pole is at C; and when the pole is in F, the summer solstice, the pole is in D. In all intermediate situations of the moon's ascending node the pole is in a point of the circumference A B C D, three signs or  $9^\circ$  more advanced. By comparing together a great number of observations, Dr. Bradley found that the mathematical theory, and the calculation depending on it, would correspond much better with the observations, if an ellipse were substituted for the circle A B C D, making the longer axis A C  $18''$ , and the shorter, B D,  $16''$ . D'Alembert determined, by the physical theory of gravitation, the axes to be  $18''$  and  $13''$ , 4. These observations, and this mathematical theory, must be considered as so many astronomical facts, and the methods of computing the places of all celestial phenomena must be drawn from them, agreeably to the universal practice of determining every point of the heavens by its longitude, latitude, right ascension, and declination.

This equation of the pole's motion makes a change in the obliquity of the ecliptic. The inclination of the equator to the ecliptic is measured by the arch of a great circle intercepted between their poles. If the pole be in O, instead of P, it is plain that the obliquity is measured by EO instead of EP. If EP be considered as the mean obliquity of the ecliptic, it is augmented by  $9''$  when the moon's ascending node is in the vernal equinox, and consequently the pole in A. It is, on the contrary, diminished  $9''$  when the node is in the autumnal equinox, and the pole in C; and it is equal to the mean when the node is in the colure of the solstices. This change of the inclination of the earth's axis to the plane of the ecliptic was called the nutation of the axis by Sir Isaac Newton; who showed that a change of nearly a second must obtain in a year by the action of the sun on the prominent parts of the terrestrial spheroid. But he did not attend to the change which would be made in this motion by the variation which obtains in the disturbing force of the moon, in consequence of the different obliquity of her action on the equator, arising from the motion of her own oblique orbit. It is this change which now goes by the name of nutation, and we owe its discovery entirely to Dr. Bradley. The general change of the position of the earth's axis has been termed deviation by modern astronomers.

It is easy to ascertain the quantity of this change of obliquity. When the pole is in O, the arch A D C O is equal to the node's longitude from the vernal equinox, and that P M is its cosine; and (on account of the smallness of A P in comparison of EP) P M may be taken for the change of the obliquity of the ecliptic. This is therefore  $= 9'' \times \cos. \text{long. node}$ , and is additive to the mean obliquity, while O is in the semicircle B A D, that is, while the longitude of.

the node is from nine signs to three signs ; but subtractive while the longitude of the node changes from three to nine signs. But the nutation changes also the longitudes and right ascensions of the stars and planets by changing the equinoctial points, and thus occasioning an equation in the precession of the equinoctial points. The great circle or meridian which passes through the poles of the ecliptic and equator is always the solstitial colure, and the equinoctial colure is at right angles to it: therefore when the pole is in P or in O, EP or EO is the solstitial colure. Let S be any fixed star or planet, and let SE be a meridian or circle of longitude ; draw the circles of declination PS, OS, and the circles M'EM', perpendicular to PE, OE. If the pole were in its mean place P, the equinoctial points would be in the ecliptic meridian M'EM', or that meridian would pass through the intersections of the equator and ecliptic, and the angle M'ES would measure the longitude of the star S. But, when the pole is in O, the ecliptic meridian mEm' will pass through the equinoctial points. The equinoctial points must therefore be to the west of their mean place, and the equation of the precession must be additive to that precession ; and the longitude of the star S will now be measured by the angle mES, which, in the case here represented, is greater than its mean longitude. The difference, or the equation of longitude, arising from the nutation of the earth's axis, is the angle OEP, or  $\frac{OM}{OE}$  OM is the sine of the angle CPO, which, by what has been already observed, is equal to the longitude of the node: Theorem OM is equal to  $9' \times \text{longitud. node}$ , and  $\frac{OM}{OE}$  is equal to  $9' \times \text{sin. long. node}$ . This equation is additive

to the mean longitude of the star when O is in the semicircle CBA, or while the ascending node is passing backwards from the vernal to the autumnal equinox ; but it is subtractive from it while O is in the semicircle ADC, or while the node is passing backwards from the autumnal to the vernal equinox ; or, to express it more briefly, the equation is subtractive from the mean longitude of the star while the ascending node is in the first six signs, and additive to it while the node is in the last six signs. This equation of longitude is the same for all the stars ; for their longitude is reckoned on the ecliptic, and therefore is affected only by the variation of the point from which the longitude is computed. The right ascension, being computed on the equator, suffers a double change. It is computed from, or begins at, a different point of the equator, and it terminates at a different point ; because, the equator having changed its position, the circles of declination also change theirs. When the pole is at P the right ascension of S from the solstitial colure is measured by the angle SPE, contained between that colure and the star's circle of declination. But, when the pole is at O, the right ascension is measured by the angle SOE, and the difference of SPE and SOE is the equation of right as-

cension. The angle SOE consists of two parts, GOE and GOS ; GOE remains the same wherever the star S is placed, but GOS varies with the place of the star.—We must first find the variation by which GPE becomes GOE, which variation is common to all the stars. The triangles GPE, GOE, have a constant side GE, and a constant angle G ; the variation PO of the side GP is extremely small, and therefore the variation of the angles may be computed by Mr. Cotes's Fluxionary Theorems. See Simpson's Fluxions, sect. 253, &c. As the tangent of the side EP, opposite to the constant angle G, is to the sine of the angle GPE, opposite to the constant side EG, so is PO the variation of the side GP, adjacent to the constant angle, to the variation  $x$  of the angle GPO, opposite to the constant side EG. This gives  $x = \frac{9' \times \text{sin. long. node}}{\text{tang. obl. eclip.}}$ .

This is subtractive from the mean right ascension for the first six signs of the node's longitude, and additive for the last six signs. This equation is common to all the stars.

We may discover the variation of the other part SOG of the angle, which depends on the different position of the hour circles PS and OS, which causes them to cut the equation in different points, where the arches of right ascension terminate, as follows :—The triangles SPG, SOG, have a constant side SG, and a constant angle G. Therefore, by the same Cotesian theorem,  $\text{tan. SP} : \text{sin. SPG} = \text{PO} : y$ , and  $y$ , or the second part of the nutation in right ascension, =  $\frac{9' \times \text{sin. diff. R. A. of star and node}}{\text{cotan. declin. star}}$ .

The nutation also affects the declination of the stars: For SP, the mean codeclination, is changed into SO.—Suppose a circle described round S, with the distance SO cutting SP in  $f$ ; then it is evident that the equation of declin. is  $Pf = PO \times \cos. OPf = 9' \times \text{sign R. A. of star} - \text{long. of node}$ .

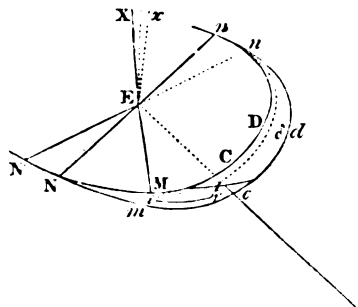
These are the calculations constantly used in our astronomical researches, founded on Machin's Theory. When still greater accuracy is required, the elliptical theory must be substituted, by taking (as is expressed by the dotted lines) O in that point of the ellipse described on the transverse axis AC, where it is cut by OM, drawn according to Machin's theory. All the change made here is the diminution of OM in the ratio of 18 to 13.4, and a corresponding diminution of the angle CPO. The detail of it may be seen in De la Lande's Astronomy, art. 2874. The calculations being in every case tedious, and liable to mistakes, on account of the changes of the signs of the different equations, the zealous promoters of astronomy have calculated and published tables of these equations.

We may now consider the precession of the equinoctial points, with its equations, arising from the nutation of the earth's axis, as a physical phenomenon, and endeavour to account for it upon those mechanical principles which have so happily explained all the other phenomena of the celestial motions. Sir Isaac Newton quickly found it to be a consequence, and the most beautiful proof, of the universal gravitation of matter. There is no part of his immortal work

where his sagacity and fertility of resource shine more conspicuously than in this investigation. His investigation, however, was only a shrewd guess, founded on assumptions, of which it would be extremely difficult to demonstrate either the truth or falsity, and which required the genius of a Newton to select in such a complication of abstruse circumstances. The subject has occupied the attention of the first mathematicians of Europe since his time; and is still considered as the most curious and difficult of mechanical problems. The most elaborate and accurate dissertations on the precession of the equinoxes are those of Sylvabella and Walmsley, in the Philosophical Transactions, published about 1754; that of Thomas Simpson, in his Miscellaneous Tracts; that of Frisius, in the Mem. of the Berlin Academy, and afterwards in his Cosmographia; that of Euler in the Memoirs of Berlin; that of D'Alembert in a separate dissertation; and that of de la Grange on the Libration of the Moon, which obtained the prize in the Academy of Paris in 1769. The dissertation of Frisius is thought the most perspicuous of them all, being conducted in the method of geometrical analysis; whereas most of the others proceed in the fluxionary and symbolic method, which does not give the same perspicuous conviction of the truth of the results.

We shall here give a short sketch of Newton's investigation. Let S (fig. 2) be the sun, E the

Fig. 2.



earth, and M the moon, moving in the orbit N M C D n, which cuts the plane of the ecliptic, in the line of the nodes N n, and has one-half raised above it, as represented in the figure, the other half being hid below the ecliptic. Suppose this orbit folded down; it will coincide with the ecliptic in the circle N m c d n. Let EX represent the axis of this orbit, perpendicular to its plane, and therefore inclined to the ecliptic. Since the moon gravitates to the sun in the direction MS, which is all above the ecliptic, it is plain that this gravitation has a tendency to draw the moon towards the ecliptic. Suppose this force to be such that it would draw the moon down from M to i in the time that she would have moved from M to t, in the tangent to her orbit. By the combination of these motions the moon will desert her orbit, and describe the line M r, which makes the diagonal of the

parallelogram; and, if no farther action of the sun be supposed, she will describe another orbit M δ n', lying between the orbit M C D n and the ecliptic, and she will come to the ecliptic, and pass through it in a point n' nearer to M than n is, which was the former place of her descending node. By this change of orbit, the line EX will no longer be perpendicular to it; but there will be another line E x which will now be perpendicular to the new orbit. Also the moon, moving from M to r, does not move as if she had come from the ascending node N, but from a point N lying beyond it; and the line of the orbit in this new position is N' n'. Also the angle M N' m is less than the angle M N m. Thus the nodes shift their places in a direction opposite to that of her motion, or move to the west; the axis of the orbit changes its position, and the orbit itself changes its inclination to the ecliptic. These momentary changes are different in different parts of the orbit, according to the position of the line of the nodes. Sometimes the inclination of the orbit is increased, and sometimes the nodes move to the east. But, in general, the inclination increases from the time that the nodes are in the line of syzygee, till they get into quadrature, after which it diminishes till the nodes are again in syzygee. The nodes advance only while they are in the octants after the quadrature, and while the moon passes from the quadrature to the node, and they recede in all other situations. Therefore the recess exceeds the advance in every revolution of the moon round the earth, and, on the whole, they recede.

What has been said of one moon would be true of each of a continued ring of moons surrounding the earth, and they would thus compose a flexible ring, which would never be flat, but waved, according to the difference (both in kind and degree), of the disturbing forces acting on its different parts. But suppose these moons to cohere, and to form a rigid and flat ring, nothing would remain in this ring but the excess of the contrary tendencies of its different parts. Its axis would be perpendicular to its plane, and its position in any moment will be the mean position of all the axes of the orbits of each part of the flexible ring. Suppose this ring to contract in dimensions, the disturbing forces will diminish in the same proportion, and in this proportion will all their effects diminish. Suppose its motion of revolution to accelerate, or the time of a revolution to diminish; the linear effects of the disturbing forces being as the square of the times of their action, and their angular effects as the times, those errors must diminish also on this account; and we can compute what those errors will be for any diameter of the ring, and for any period of its revolution. We can tell, therefore, what would be the motion of the nodes, the change of inclination, and deviation of the axis, of a ring which would touch the surface of the earth, and revolve in twenty-four hours; nay, we can tell what these motions would be, should this ring adhere to the earth. They must be much less than if the ring were detached. For the disturbing forces of the ring must drag along with it the whole globe of the earth. The quantity of motion which the disturbing forces would have produced in the ring

alone. will now, says Newton, be produced in the whole mass; and therefore the velocity must be as much less as the quantity of matter is greater: but still all this can be computed.

That there is such a ring on the earth is certain; for the earth is not a sphere, but an elliptical spheroid. Sir Isaac Newton, therefore, made a computation of the effects of the disturbing force, and has exhibited a most beautiful example of mathematical investigation. He first asserts that the earth must be an elliptical spheroid, whose polar axis is to its equatorial diameter as 229 to 230. Then he demonstrates that if the sine of the inclination of the equator be called  $\pi$ , and if  $t$  be the number of days (sidereal) in a year, the annual motion of a detached ring will

be  $360^\circ \times \frac{3\sqrt{1-\pi^2}}{4t}$ . He then shows that

the effect of the disturbing force on this ring is to its effect on the matter of the same ring, distributed in the form of an elliptical stratum (but still detached) as 5 to 2; therefore the motion

of the nodes will be  $360^\circ \times \frac{3\sqrt{1-\pi^2}}{10t}$ , or  $16'$

$16' 24''$  annually. He then proceeds to show that the quantity of motion in the sphere is to that in the equatorial ring revolving in the same time, as the matter in the sphere to the matter in the ring, and as three times the square of a quadrantal arch to two squares of a diameter, jointly: then he shows that the quantity of matter in the terrestrial sphere is to that in the protuberant matter of the spheroid as 52900 to 461 (supposing all homogeneous). From these premises it follows that the motion of  $16' 16'' 24''$  must be diminished in the ratio of 10717 to 100, which reduces it to  $9' 07''$  annually. And this, he says, is the precession of the equinoxes, occasioned by the action of the sun; and the rest of the  $50\frac{1}{2}'$ , which is the observed precession, is owing to the action of the moon nearly five times greater than that of the sun. This appeared a great difficulty; for the phenomena of the tides show that it cannot much exceed twice the sun's force.

The ingenuity of this process is justly celebrated by Daniel Bernouilli, who (in his Dissertation on the Tides, which shared the prize of the French Academy with M'Laurin and Euler) says that Newton saw through a veil what others could hardly discover with a microscope in the light of the meridian sun. His determination of the form and dimensions of the earth, which is the foundation of the whole process, is not offered as any thing better than a probable guess, in re difficilima; and it has been since demonstrated with geometrical rigor by M'Laurin. His next

principle, that the motion of the nodes of the rigid ring is equal to the mean motion of the nodes of the moon, has been most critically discussed by the first mathematicians, as a thing which could neither be proved nor refuted. Frisius has at last shown it to be a mistake, and that the motion of the nodes of the ring is double the mean motion of the nodes of a single moon; and that Newton's own principles should have produced a precession of eighteen seconds and a quarter annually; which removes the difficulty formerly mentioned.

Sir Isaac Newton's third assumption, that the quantity of motion of the ring must be shared with the included sphere, was acquiesced in by all his commentators, till D'Alembert and Euler, in 1749, showed that it was not the quantity of motion round an axis of rotation which remained the same, but the quantity of momentum or rotatory effort. The quantity of motion is the product of every particle by its velocity; that is, by its distance from the axis; while its momentum, or power of producing rotation, is as the square of that distance, and is to be had by taking the sum of each particle multiplied by the square of its distance from the axis. Since the earth differs so little from a perfect sphere, this makes no sensible difference in the result. It will increase Newton's precession about three-fourths of a second.

The source of Newton's mistake in the solution of this intricate problem was first detected by Mr. Landen, in the first volume of his Memoirs. That superior mathematician discovered that when a rigid annulus revolves with two motions, one in its own plane, and the other round one of its diameters, half the motive force acting upon the ring is counteracted by the centrifugal force arising from the compound motion, and half only is efficacious or accelerating the plane of the annulus round its diameter. Mr. Landen did not expressly demonstrate this; but it has been done very completely by Dr. Brinkley, in the seventh volume of the Memoirs of the Irish Academy. We cannot here pursue this subject; but beg to refer the reader to Dr. Milner's paper in the Philosophical Transactions; to Dr. Abram Robertson's paper in the Philosophical Transactions for 1807; to the Dissertation of Frisius already specified; and to the popular view of this problem by M. Laplace in his Exposition, book iv. ch. 13.

To find the precession in right ascension and declination.—Put  $d$  = the declination of a star, and  $a$  = its right ascension; then their annual variations of precessions will be nearly as follow, viz.  $20'' \cdot 084 \times \cos. a$  = the annual precession in declinat, and  $46'' \cdot 0619 + 20'' \cdot 084 \times \sin. a \times \text{tang. } d$  = that of right ascension.

PRECIÆ, *precious*, early, the twenty-first order in Linnæus's fragments of a natural method; consisting of primrose, an early flowering plant, and a few genera which agree with it in habit and structure. See BOTANY.

PRECINCT, *n. s.* Lat. *præcinctus*. Outward limit; boundary.

The main body of the sea being one, yet within divers *precincts*, hath divers names; so the catholic church is in like sort divided into a number of distinct societies.

Hooker.

This is the manner of God's dealing with those that have lived within the *precincts* of the church; they shall be condemned for the very want of true faith and repentance.

Perkins.

Through all restraint broke loose, he wings his way  
 Nor far off heaven, in the *precincts* of light,  
 Directly towards the new created world. *Milton.*  
 To find our hearthstone turned into a tomb,  
 And round its once warm *precincts* palely lying  
 The ashes of our hopes, is a deep grief,  
 Beyond a single gentleman's belief. *Byron.*

**PRECIOUS**, *adj.* } Fr. *precieux*; Latin  
**PRECIOUSLY**, *adv.* } *pretiosus*. Valuable;  
**PRECIOUSNESS**, *n. s.* } of great worth; costly;  
 often used in irony; the adverb and noun-substantive follow the senses of the adjective.

A woman that hadde a boxe of alabastre of *precious* oynement cam to him and schedde out on the heed of him restynge. *Wiclif. Matt. 26.*

The lips of knowledge are a *precious* jewel.

*Prov. xx. 15.*

Many things which are most *precious*, are neglected only because the value of them lieth hid. *Hooker.*

I never saw

Such *precious* deeds in one that promised nought  
 But beggry and poor luck. *Shakspeare. Cymbeline.*  
 Its *preciousness* equalled the price of pearls. *Wilkins.*

Let none admire

That riches grow in hell; that soil may best  
 Deserve the *precious* bane. *Milton.*

The index or forefinger was too naked whereto to commit their *preciosities*, and hath the tuition of the thumb scarce unto the second joint. *Browne.*

Barbarians seem to exceed them in the curiosity of their application of these *preciosities*. *More.*

Fortune, conscious of your destiny,

Ev'n then took care to lay you softly by;  
 And wrapp'd your fate among her *precious* things,  
 Kept fresh to be unfolded with your king's.

*Dryden.*

More of the same kind, concerning these *precious* saints amongst the Turks, may be seen in Pietro della Valle. *Locke.*

These virtues are the hidden beauties of a soul which make it lovely and *precious* in his sight, from whom no secrets are concealed. *Addison's Spectator.*

**PRECIPICE**, *n. s.* Fr. *precipice*; Lat. *præcipitium*. A headlong or perpendicular steep.

I ere long that *precipice* must tread,  
 Whence none return that leads unto the dead.

*Sandys.*

You take a *precipice* for no leap of danger,  
 And woo your own destruction. *Shakspeare.*

Where the water dasheth more against the bottom, here it moveth more swiftly and more in *precipice*; for in the breaking of the waves there is ever a *precipice*. *Bacon.*

No stupendous *precipice* denies  
 Access, no horror turns away our eyes. *Denham.*

Swift down the *precipice* of time it goes,  
 And sinks in minutes, which in ages rose. *Dryden.*

Drink as much as you can get; because a good coachman never drives so well as when he is drunk; and then shew your skill, by driving to an inch by a *precipice*. *Swift.*

**PRECIPITANCE**, or  
**PRECIPITANCY**, *n. s.* } Latin  
**PRECIPITANT**, *adj.* } *precipitans*.  
**PRECIPITANTLY**, *adv.* } Haste;  
**PRECIPITATE**, *v. a., v. n., adj. & n. s.* } rash  
**PRECIPITATELY**, *adv.* } haste;  
**PRECIPITATION**, *n. s.* } hurry;  
**PRECIPITOUS**. } precipi-

tant is, falling or rushing headlong; hasty; hurried: the adverb corresponding: precipitate, to urge or throw headlong; urge on with violence; hasten; hurry blindly; throw to the bottom by a chemical process: as a verb neuter, to fall headlong; fall to the bottom: precipitate as an adjective is synonymous with precipitant: as a noun substantive, it is a medical term for the red oxide of mercury: precipitately and precipitation correspond with the adjective: precipitous is, steep; headlong; hasty; rash.

Hadst thou been aught but goss'mer feathers,  
 So many fathom down *precipitating*,  
 Thou'dst shiver like an egg. *Shakspeare. King Lear.*

Let them pile ten hills on the Tarpeian rock,

That the *precipitation* might down-stretch

Below the beam of sight, yet will I still

Be this to them. *Id. Coriolanus.*

Barcephas saith, it was necessary this paradise should be set at such a height, because the four rivers, had they not fallen so *precipitate*, could not have had sufficient force to thrust themselves under the great ocean. *Raleigh.*

She had a king to her son-in-law, yet was, upon dark and unknown reasons, *precipitated* and banished the world into a nunnery. *Bacon.*

As for having them obnoxious to ruin, if they be of fearful natures, it may do well; but, if they be daring, it may *precipitate* their designs, and prove dangerous. *Id.*

By strong water every metal will *precipitate*. *Id.*

Separation is wrought by *precipitation* or sublimation; that is, a calling of the parts up or down which is a kind of attraction. *Id.*

The commotions in Ireland were so sudden and so violent, that it was hard to discern the rise, or apply a remedy to that *precipitant* rebellion. *King Charles.*

Monarchy, together with me, could not but be dashed in pieces by such a *precipitous* fall as they intended. *Id.*

Short intermittent and swift recurrent pains do *precipitate* patients into consumptions. *Haree.*

They were wont, upon a superstition, to *precipitate* a man from some high cliff into the sea, tying about him with strings many great fowls. *Wilkins.*

Dear Erythraea, let not such blind fury

*Precipitate* your thoughts, nor set them working,

Till time shall lend them better means

Than lost complaints. *Denham's Sophy.*

The archbishop, too *precipitate* in pressing the reception of that which he thought a reformation, paid dearly for it. *Clarendon.*

Thither they haste with glad *precipitance*. *Milton.*

Without longer pause,

Downright into the world's first region throws

His flight *precipitant*. *Id. Paradise Lost.*

As the chymist, by catching at it too soon, loses the philosophical elixir, so *precipitancy* of our understanding is an occasion of error. *Glauville.*

Though the attempts of some have been *precipitous*, and their enquiries so audacious as to have lost themselves in attempts above humanity, yet have the enquiries of most defected by the way. *Browne's Vulgar Errors.*

The goddess guides her son, and turns him from the light.

Herself involved in clouds, *precipitates* her flight. *Dryden.*

Thus framed for ill, he loosed our triple hold,

Advice unsafe, *precipitous*, and bold. *Id.*

How precious the time is, how *precipitous* the oc-

cession, how many things to be done in their just season, after once a ground is in order. *Evelyn.*

The birds heedless while they strain  
Their tuneful throats, the towering heavy lead  
O'ertakes their speed; they leave their little lives  
Above the clouds, precipitant to earth. *Philips.*

Gold endures a vehement fire long without any change, and, after it has been divided by corrosive liquors into invisible parts, yet may presently be precipitated, so as to appear again in its own form.

*Grew's Cosmologia.*

When the full stores their ancient bounds disdain,  
Precipitate the furious torrent flows;  
In vain would speed avoid, or strength oppose.

*Prior.*

That could never happen from any other cause than the hurry, precipitation, and rapid motion of the water, returning at the end of the deluge towards the sea. *Woodward.*

Mr. Gay died of a mortification of the bowels; it was the most precipitate case I ever knew, having cut him off in three days. *Arbutnot.*

As the escar separated, I rubbed the superescrescence with the vitriol stone, or sprinkled it with precipitate. *Wiscman.*

Should he return, that troop so blithe and bold,  
Precipitant in fear, would wing their flight,  
And curse their cumbrous pride's unwieldy weight.

*Pope.*

Not so bold Arnall; with a weight of skull  
Furious he sinks, precipitately dull.

*Id. Dunciad.*

Hurried on by the precipitancy of youth, I took this opportunity to send a letter to the secretary.

*Swift.*

A rashness and precipitance of judgment, and hastiness to believe something on one side or the other, plunges us into many errors. *Watts's Logick.*

We are complicated machines; and though we have one main spring, that gives motion to the whole, we have an infinity of little wheels, which, in their turns, retard, precipitate, and sometimes stop, the motion. *Chesterfield.*

PRECIPITATION, in chemistry, the process of decomposition by which any body separates from others in a solution and falls to the bottom: thus, if to an acid and an oxide a third body as an alkali be added, then the alkali having a greater affinity to the acid than the metallic oxide has, combines with it, and the oxide in consequence precipitates, or appears in a separate state at the bottom. The substance thus sinking is called the precipitate, and that, by the addition of which this effect is produced is called the precipitant. Sir Humphry Davy found that whenever one metal precipitates another from its acid solution, the body that falls down is usually free both from acid and oxygen; and that the whole of the oxygen and the acid, is transferred from one metal to the other.

PRECISE, *adj.* } Fr. *precis*; Lat. *præ-*  
PRECISELY, *adv.* } *cisus*. Exact; strict;  
PRECISENESS, *n. s.* } nice; having definite limits; formal: precisely and preciseness correspond with this, and precision is synonymous with the latter: a precisian is one who limits or restrains with exactness or rigor: precise, exactly limited.

In his track my wary feet have stept,

His undeclined ways precisely kept. *Sandys.*  
Means more durable to preserve the laws of God

from oblivion and corruption grew in use, not with out precise direction from God himself. *Hooker.*

Doth it follow that all things in the church, from the greatest to the least, are unholy, which the Lord hath not himself precisely instituted? *Id.*

You'll not bear a letter for me; you stand upon your honour; why, thou unconfinable baseness, it is as much as I can do to keep the term of mine honour precise. *Shakespeare.*

He knows,

He cannot so precisely weed this land

As his misdoubts present occasion,

His foes are so enrooted with his friends. *Id.*

Though love use reason for his precisian, he admits him not for his counsellor. *Id.*

The state hath given you licence to stay on land six weeks, and let it not trouble you if your occasions ask farther time; for the law in this point is not precise. *Bacon.*

I will distinguish the cases; though give me leave, in the handling of them, not to sever them with too much preciseness. *Id.*

These men, for all the world, like our precisians be,

Who for some cross or saint they in the window see  
Will pluck down all the church. *Drayton.*

Where more of the orders than one shall be set in several stories, there must be an exquisite care to place the columns precisely one over another.

*Wotton's Architecture.*

In human actions there are no degrees and precise natural limits described, but a latitude is indulged.

*Taylor.*

Let us descend from this top

Of speculation; for the hour precise

Exacts our parting. *Milton's Paradise Lost.*

The rule, to find the age of the moon, cannot shew precisely an exact account of the moon, because of the inequality of the motions of the sun and of the moon. *Holder.*

He that thinks of being in general, thinks never of any particular species of being: unless he can think of it with and without precision at the same time. *Locke.*

The raillery of the wits in king Charles the Second's reign, upon every thing which they called precise, was carried to so great an extravagance that it almost put all Christianity out of countenance.

*Addison.*

Measuring the diameter of the fifth dark circle,  
I found it the fifth part of an inch precise.

*Newton's Opticks.*

The reasonings must be precise, though the practice may admit of great latitude. *Arbutnot.*

I was unable to treat this part more in detail, without sacrificing perspicuity to ornament, without wandering from the precision or breaking the chain of reasoning. *Pope.*

The precise difference between a compound and collective idea is this, that a compound idea unites things of a different kind, but a collective, things of the same kind. *Watts.*

A profane person calls a man of piety a precisian. *Id.*

Precise abstraction is when we consider those things apart which cannot really exist apart; as when we consider mode, without considering its substance or subject. *Id.*

What is the world? a term which men have got  
To signify not one in ten knows what.

A term which with no more precision passes,  
To point out herds of men than heads of asses!  
In common use no more it means, we find,  
Than many fools in same opinions joined.

*Churchill.*



**PRECLUDE', v. a.** Lat. *præcludo*. To shut out or hinder by anticipation.

This much will obviate and *preclude* the objections of our adversaries, that we do not determine the final cause of the systematical parts of the world, merely as they have respect to the exigencies or conveniences of life. *Bentley.*

If you once allow them such an acceptation of chance, you have *precluded* yourself from any more reasoning against them. *Id.*

I fear there will be no way left to tell you, that I entirely esteem you; none but that which no bills can *preclude*, and no king can prevent. *Pope.*

**PRECOCIOUS, adj.** } Fr. *precoce*; Latin }  
**PRECOCITY.** } *præcōsis*. Ripe before }  
the time: too early ripeness.

I may say of the younglings of our time, that *precocity* of understanding supplieth age and stature. *Bp. Hall.*

Some impute the cause of his fall to a *precocity* of spirit and valour in him; and that therefore some infectious southern air did blast him. *Howel.*

Many *precocious* trees, and such as have their spring in the winter, may be found in most parts. *Browne.*

And every body but his mother deemed Him almost man; but she flew in a rage  
And bit her lips (for else she might have screamed)  
If any said so, for to be *precocious*  
Was in her eyes a thing the most atrocious. *Byron.*

**PRECONCEIT', n. s.** *Præ* and conceit. An opinion previously formed.

A thing in reason impossible, which notwithstanding through their misfashioned *preconceit* appeared unto them no less certain than if nature had written it in the very foreheads of all the creatures. *Hooker.*

In a dead plain the way seemeth the longer because the eye hath *preconceited* it shorter than the truth; and the frustration of that maketh it seem so. *Bacon.*

Custom with most men prevails more than truth; according to the notions and *preconceptions* which it hath formed in our minds, we shape the discourse of reason itself. *Hakewill.*

Fondness of *preconceived* opinions is not like to render your reports suspect, nor for want of care, defective. *Glanville.*

The reason why men are so weak in governing is, because most things fall out accidentally, and come not into any compliance with their *preconceived* ends, but they are forced to comply subsequently. *South.*

**PRECONTRACT, n. s.** *Præ* and contract. As a verb, accented on the last syllable. A contract previous to another.

He is your husband on a *precontract*;  
To bring you thus together, 'tis no sin. *Shakspeare.*

Some are such as a man cannot make his wife, though he himself be unmarried, because they are already *precontracted* to some other; or else are in too near a degree of affinity or consanguinity. *Ayliffe.*

**PRECURSE, n. s.** • Lat. *præcurro*. Fore-running.

The like *precurse* of fierce events,  
As harbingers preceding still the fates,  
And prologue to the omen coming on  
Have heaven and earth together demonstrated. *Shakspeare.*

Jove's lightnings, the *precursors*  
Of dreadful thunder claps, more momentary  
Were not. *Id. Tempst.*

This contagion might have been *presaged* upon consideration of its *precursors*, viz. a rude winter, and a close, sulphurous and fiery air. *Harvey.*

Thomas Burnet played the *precursor* to the coming of Homer in his *Homendes*. *Pope.*

**PREDACEOUS, adj.** } Lat. *præda*. Liv- }  
**PREDAL,** } ing by prey; plun }  
**PREDATORY.** } dering.

The king called his parliament, where he exaggerated the malice and the cruel *predatory* war made by Scotland. *Bacon.*

As those are endowed with poison, because they are *predaceous*: so these need it not, because their food is near at hand, and may be obtained without contest. *Derham.*

Sarmat'a, laid by *predal* rapine low,  
Mourned the hard yoke, and sought relief in vain. *Boyse.*

**PREDECEASED, adj.** *Præ* and deceased. Dead before.

Will you mock at an ancient tradition, begun upon an honourable respect, and worn as a memorable trophy of *predeceased* valour? *Shakspeare.*

**PREDECESSOR, n. s.** Fr. *predecesseur*; Lat. *præ* and *decedo*. One that was in any state or place before another; an ancestor.

In these pastoral pastimes a great many days were spent to follow their flying *predecessors*. *Sidney.*

There is cause why we should be slow and unwilling to change, without very urgent necessity, the ancient ordinances, rites, and approved customs of our venerable *predecessors*. *Hooker.*

If I seem partial to my *predecessor* in the laurel, the friends of antiquity are not few. *Dryden.*

The present pope, who is well acquainted with the secret history, and the weakness of his *predecessor*, seems resolved to bring the project to its perfection. *Addison.*

The more beauteous Chloe sat to thee,  
Good Howard, emulous of Apelles' art;  
But happy thou from Cupid's arrow free,  
And flames that pierced thy *predecessor's* heart. *Prior.*

**PREDESTINATE, v. a. & v. n.** } Fr. *pre-* }  
**PREDESTINARIAN, n. s.** } destiner; }  
**PREDESTINATION,** } Latin *præ* }  
**PREDESTINATOR,** } and *desti-* }  
**PREDESTINE, v. a.** } no. To ap-

point beforehand: in ludicrous language, to hold predetermination: predeterminarian, one who holds that doctrine; see below. Predeterminator is used out of all analogy by Cowley as synonymous with predeterminarian: to predetermine is to decree beforehand.

Whom he did foreknow, he also did *predetermine* to be conformed to the image of his son. *Romans.*

Having *predetermined* us unto the adoption of children by Jesus Christ to himself. *Ephesians i. 5.*

Some gentleman or other shall 'scape a *predetermined* scratcht face. *Shakspeare.*

*Predetermination* we can difference no otherwise from providence and prescience, than this, that prescience only foreseeth, providence foreseeth and careth for, and hath respect to all creatures, and *predetermination* is only of men; and yet not of all to men belonging, but of their salvation properly in the common use of divines; or perdition, as some have used it. *Rutleigh's History of the World*

Why does the *predestinarian* so adventurously climb  
unto heaven, to ransack the celestial archives, read  
God's sudden decrees, when with less labour he may  
secure an autubentuck transcript within himself?

*Decay of Piety.*

Me, mine example let the Stoicks use,  
Their sad and cruel doctrine to maintain;  
Let all *predestinators* me produce,  
Who struggle with eternal fate in vain. *Cowley.*

Nor can they justly accuse  
Their maker, or their making, or their fate;  
As if *predestination* overruled  
Their will, disposed by absolute decree,  
Or high fore-knowledge.

*Milton's Paradise Lost.*

His ruff crest he rears,  
And pricks up his *predestinating* ears.

*Dryden.*

Ye careful angels, whom eternal fate  
Ordains on earth and human acts to wait,  
Who turn with secret power this restless ball,  
And bid *predestined* empires rise and fall. *Prior.*

PREDESTINATION is, according to the Calvinistic writers, the decree of God, whereby he hath from all eternity unchangeably appointed whatsoever comes to pass; and hath more especially fore-ordained certain individuals of the human race to everlasting happiness, and hath passed by the rest, or fore-ordained them to everlasting misery. The former of these are called the elect, and the latter the reprobate. This doctrine is the subject of one of the most perplexing controversies that have occurred among mankind. But it is not peculiar to the Christian faith. It has always been in some degree a popular opinion, and has been believed by many speculative men. The ancient Stoicks, Zeno and Chrysippus, whom the Jewish Essenes seem to have followed, asserted the existence of a Deity that, acting wisely, but necessarily, contrived the general system of the world; from which, by a series of causes, whatever is now done in it unavoidably results. This series or concatenation of causes, they held to be necessary in every part; and that God himself is so much the servant of necessity, and of his own decrees, that he could not have made the smallest object in the world otherwise than it now is, much less is he able to alter any thing. Seneca gives a similar account of the doctrine of fate. See NECESSITY. The Stoical fate differs, however, from the Christian predestination in several points. They regard the divine nature and will as a necessary part of a chain of causes; whereas all Christians consider the Deity as the Lord and Ruler of the universe, omnipotent and free, appointing all things according to his pleasure. Being doubtful of the immortality of the soul, the Stoicks could have no idea of the doctrine of election and reprobation; nor did they ever doubt their own freedom of will, or power of doing good as well as evil, as the Christian predestinarians have done. Mahomet introduced into his Koran the doctrine of an absolute predestination in the strongest terms. In the Christian Church the controversy concerning predestination first made its appearance about the beginning of the fifth century, in consequence of the heretical opinions advanced by Pelagius and Cælestus. See PELAGIANS. These were zealously

opposed by the celebrated St. Augustine, bishop of Hippo, who first asserted the leading tenets of the Predestinarians. The dispute was carried on with great zeal. Zosimus, bishop of Rome, decided at first in favor of Pelagius, but afterwards altered his opinion. The council of Ephesus approved of St. Augustine's doctrine, and condemned that of his opponents. These opinions soon after assumed various modifications. A party called predestinarians carried Augustine's doctrine farther than he had done, and said that God had decreed the sins as well as punishment of the wicked. Another party moderated Pelagius's doctrine, and were called SEMI-PELAGIANS. (See that article.) But the doctrine of St. Augustine, who wrote several treatises on the subject, became general. He was the oracle of the school-men. They only disputed about the true sense of his writings.

The whole of the earliest reformers maintained these opinions of Augustine. Under Luther they only assumed a more regular and systematic form than they had before exhibited. But, as the Lutherans afterwards abandoned them, they are now known by the name of Calvinistic doctrines, from John Calvin of Geneva. The opponents of the doctrine of predestination among the Protestants usually receive the appellation of Arminians or Remonstrants. They derive the first of these appellations from James Arminius, professor of the theology at Leyden, and the second from the Arminians who remonstrated against the synod of Dort. (See ARMINIUS.) A counter remonstrance was presented, containing the opinions of the Calvinists, which was approved of by the synod. The substance of it was afterwards adopted in nearly the same expressions into the Confession of Faith, compiled by the assembly of divines at Westminster in 1643; which every clergyman of the church of Scotland subscribes previous to his admission. It runs thus:—'God from all eternity did, by the most wise and holy counsel of his own will, freely and unchangeably ordain whatsoever comes to pass: yet so, as thereby neither is God the author of sin, nor is violence offered to the will of the creatures, nor is the liberty or contingency of second causes taken away, but rather established. Although God knows whatsoever may or can come to pass upon all supposed conditions; yet hath he not decreed any thing because he foresaw it as future, or that which would come to pass upon such conditions. By the decree of God, for the manifestation of his glory, some men and angels are predestinated unto everlasting life, and others are fore-ordained to everlasting death. These angels and men, thus predestinated and fore-ordained, are particularly and unchangeably designed; and their number is so certain and definite that it cannot be either increased or diminished. Those of mankind that are predestinated unto life, God, before the foundation of the world was laid, according to his eternal and immutable purpose, and the secret council and good pleasure of his will, hath chosen, in Christ, unto everlasting glory, out of his mere free grace and love, without any foresight of faith, good works, or perseverance in either of them, or any other thing in the

creature, as conditions or causes moving him thereunto; and all to the praise of his glorious grace. As God hath appointed the elect unto glory, so hath he, by the eternal and most free purpose of his will, fore-ordained all the means thereunto. Wherefore, they who are elected, being fallen in Adam, are redeemed by Christ, are effectually called unto faith in Christ, by his Spirit working in due season; are justified, adopted, sanctified, and kept, by his power through faith unto salvation. Neither are any other redeemed by Christ, effectually called, justified, adopted, sanctified, and saved, but the elect only. The rest of mankind God was pleased, according to the unsearchable counsel of his own will, whereby he extended or withholdeth mercy as he pleaseth, for the glory of his sovereign power over his creatures, to pass by, and to ordain them to dishonor and wrath for their sin, to the praise of his glorious justice.'

There are two kinds of modern Calvinists or Predestinarians, viz. the Supralapsarians, who maintain that God did originally and expressly decree the fall of Adam, as a foundation for the display of his justice and mercy; while those who maintain that God only permitted the fall of Adam are called Sublapsarians; their system of decrees concerning election and reprobation being, as it were, subsequent to that event. But, as Dr. Priestley justly remarks, if we admit the divine prescience, there is not, in fact, any difference between the two schemes; and, accordingly, that distinction is now seldom mentioned. Nor was the church of Rome less agitated by the contest about predestination than the first Protestants were. The council of Trent was much perplexed how to settle the matter without giving offence to the Dominicans, who were much attached to the doctrine of Augustine, and possessed great influence in the council. After much dispute, the great object came to be, how to contrive such a decree as might give offence to nobody, and decide nothing. Upon the whole, however, they seem to have favored the Semipelagian scheme. Among other things, it was determined that good works are of themselves meritorious to eternal life; but it is added, by way of softening, that it is through the goodness of God that he makes his own gifts to be merits in us. Catarin revived at that council an opinion of some of the schoolmen, that God chose a small number of persons, such as the blessed virgin, the apostles, &c., whom he was determined to save without any foresight of their good works; and that he also wills that all the rest should be saved, providing for them all necessary means, but they are at liberty to use them or not. This is called in England the Baxterian scheme. The Jesuits at first followed the opinion of Augustine; but afterwards forsook it. Molina, one of their order, was the author of what is called the middle scheme, or the doctrine of a grace sufficient for all men, but subject to the freedom of the human will. Jansenius, a doctor of Louvain, opposed the Jesuits with great vigor, and supported the doctrine of Augustine. (See JANSENISTS.) But the Jesuits had sufficient interest at Rome to procure the

opinions of Jansenius to be condemned. These disputes have never been fully settled, and still divide even the Roman Catholic church. Some of the ablest supporters of Predestination have appeared among the Jansenists, and particularly among the gentlemen of Port-Royal. With regard to Great Britain, the earliest English reformers were in general Sublapsarians, although some of them were Supralapsarians. But the rigid Predestinarians have been gradually declining in number in that church, although they still subscribe the thirty-nine articles. The celebrated Scottish Reformer, John Knox, having been educated at Geneva, established in his own country the doctrine of predestination in its strictest form: and it has probably been adhered to more strictly in Scotland than in any part of Europe. Of late years, however, the dispute concerning predestination has assumed a form considerably different from that which it formerly possessed. Instead of being considered as a point to be determined almost entirely by the Sacred Scriptures, it has, in the hands of a number of able writers, in a great measure resolved itself into a question of natural religion, under the head of the philosophical liberty or necessity of the will. (See METAPHYSICS and NECESSITY.) Readers who wish for farther information on this subject may consult the writings of lord Kames, Jonathan Edwards, and Dr. Priestley, one of the most celebrated Necessitarians of his age. To give even a sketch of the arguments on both sides would far exceed our bounds. Milton, an eminent philosopher and divine, as well as the first of poets, when he wished to exhibit the fallen angels themselves as perplexed by questions above their comprehension, set them to dispute about predestination:—

They reasoned high, of knowledge, will, and fate,  
Fixed fate, free-will, fore-knowledge absolute;  
And found no end, in wand'ring mazes lost.

**PREDETERMINE**, *v. a.* *Præ* and determine. To doom or confine by previous decree.

We see in brutes certain sensible instincts antecedent to their imaginative faculty, whereby they are *predetermined* to the convenience of the sensible life.

*Hale.*

This *predetermination* of God's own will is so far from being the determining of ours, that it is distinctly the contrary; for supposing God to predetermine that I shall act freely; 'tis certain from thence, that my will is free in respect of God, and not *predetermined*.

*Hammond's Fundamentals.*

The truth of the catholic doctrine of all ages, in points of *predetermination* and irresistibility, stands in opposition to the Calvinists.

*Hammond.*

**PRE'DIAL**, *adj.* *Lat. prædiun.* Consisting of farms.

By the civil law, their *predial* estates are liable to fiscal payments and taxes, as not being appropriated for the service of divine worship, but for profane uses.

*Ayliffe.*

**PREDICABLE**, *n. s. & adj.* *Lat. prædicabile.* A logical term, denoting one of the five things which can be affirmed: such as may be affirmed: predicament is a class or arrangement of beings

or things: hence class case or condition of any kind: predicant, one who affirms: to predicate, to affirm any thing of another: to comprise an affirmation; affirm in any way; or that which is affirmed or denied of the subject: predication, affirmation.

The offender's life lies in the mercy  
Of the duke only, 'gainst all other voice;  
In which *predicament* I say thou stand'st.

*Shakespeare.*

I shew the line and the *predicament*,  
Wherein you range under this subtle king. *Id.*  
God then is light in himself; so in relation to us:  
and this *predication* of light serves to confirm our  
conformity to God in his behalf. *Bp. Hall.*

If there were nothing but bodies to be ranked by  
them in the *predicament* of place, then that descrip-  
tion would be allowed by them as sufficient.

*Digby on Bodies.*

It were a presumption to think that any thing in  
any created nature can bear any perfect resemblance  
of the incomprehensive perfection of the divine na-  
ture, very being itself not *predicating* univocally  
wouching him and any created being. *Hale.*

All propositions, wherein a part of the complex  
idea, which any term stands for, is *predicated* of that  
term, are only verbal; v. g. to say that gold is a  
metal. *Locke.*

Let us reason from them as well as we can; they  
are only about identical *predications* and influence.

*Id.*

These they call the five *predicables*; because every  
thing that is affirmed concerning any being, must be  
of the genus, species, difference, some property, or acci-  
dent. *Watts.*

The *predicate* is that which is affirmed or denied of  
the subject. *Id. Logick.*

PREDICT, v. a. } Fr. *prédire*; Lat. *præ-*  
PREDICTION, n. s. } *dictus*. To foretell; to  
PREDICTOR. } foreshow: prediction is  
declaration or revelation of something future;  
prophecy: predictor is a foreteller.

These *predictions*

Are to the world in general, as to Cæsar.

*Shakespeare.*

The *predictions* of cold and long winters, hot and  
dry summers, are good to be known. *Bacon.*

How soon hath thy *prediction*, seer blest!

Measured this transient world the race of time,

Till time stand fixed. *Milton's Paradise Lost.*

In Christ they all meet with an invincible evi-  
dence, as if they were not *predictions*, but after-rela-  
tions; and the penmen of them not prophets but  
evangelists. *South.*

He is always inveighing against such unequal dis-  
tributions; nor does he ever cease to *predict* publick  
ruins, till his private are repaired.

*Government of the Tongue.*

He, who prophesied the best,

Approves the judgment to the rest;

He'd rather choose that I should die,

Than his *prediction* prove a lie.

*Swift's Miscellanies.*

Whether he has not been the cause of this poor  
man's death, as well as the *predictor*, may be dis-  
puted. *Swift.*

PREDIGESTION, n. s. *Præ* and digestion.  
Digestion too soon performed.

*Predigestion*, or hasty digestion, fills the body  
full of crudities and seeds of diseases.

*Bacon's Essays.*

PREDISPOSE, v. a. *Præ* and dispose. To  
adapt previously to any certain purpose.

Tunes and airs have in themselves some affinity  
with the affections; so as it is no marvel if they  
alter the spirits, considering that tunes have a *pre-*  
*disposition* to the motion of the spirits. *Bacon.*

Vegetable productions require heat of the sun, to  
*predispose*, and excite the earth and the seeds.

*Burnet.*

Unless nature be *predisposed* to friendship by its  
own propensity, no arts of obligation shall be able  
to abate the secret hatred of some persons towards  
others. *South.*

External accidents are often the occasional cause  
of the king's evil; but they suppose a *pre disposition*  
of the body. *Wiseman.*

PREDOMINATE, v. n. } Fr. *predominer*;  
PREDOMINANCE, n. s. } Lat. *præ* and *do-*  
PREDOMINANT, adj. } *minor*. To pre-  
vail; be ascendant; be supreme: predominance  
is prevalence; superiority; ascendancy: predo-  
minant, prevalent; ascendant.

Miserable were the condition of that church, the  
weighty affairs whereof should be ordered by those  
deliberations, wherein such an humour as this were  
*predominant*. *Hooker.*

We make guilty of our disasters, the sun, the  
moon, and the stars, as we if we were knaves, thieves,  
and treacherous by spherical *predominance*.

*Shakespeare.*

Foul subordination is *predominant*,  
And equity exiled your highness' land. *Id.*  
Those helps were outweighed by things that  
made against him, and were *predominant* in the  
king's mind. *Bacon.*

So much did love 't her executed lord  
*Preponderate* in this fair lady's heart.

*Daniel.*

In human bodies there is an incessant warfare  
amongst the humours for *predominancy*. *Howel.*

Whether the sun, *predominant* in heaven,  
Rise on the earth; or earth rise on the sun.

*Milton.*

An inflammation consists only of a sanguineous  
effluxion, or else is denominable from other humours,  
according to the *predominancy* of melancholy, phlegm,  
or choler. *Brounne.*

The true cause of the Pharisees' disbelief of  
Christ's doctrine was, the *predominance* of their co-  
vetousness and ambition over their will. *South.*

The gods formed women's souls out of these prin-  
ciples which compose several kinds of animals; and  
their good or bad disposition arises, according as  
such and such principles *predominate* in their consti-  
tutions. *Addison.*

The several rays in white light do retain their co-  
lorific qualities, by which those of any sort, when-  
ever they become more copious than the rest, do, by  
their excess and *predominance*, cause their proper co-  
lour to appear. *Newton.*

The rays, reflected least obliquely, may *predomi-*  
*nate* over the rest, so much as to cause a heap of such  
particles to appear very intensely of their colour.

*Id. Opticks.*

I could shew you several pieces, where the beauties  
of this kind are so *predominant*, that you could never  
be able to read or understand them. *Swift.*

Where judgment is at a loss to determine the  
choice of a lady who has several lovers, fancy may  
be the more allowably *predominate*. *Clarissa.*

If ever he fell into a fit of the gout, or if any other  
cause withdrew him from public cares, principles di-  
rectly contrary were sure to *predominate*.

*Burke. Character of Lord Chatham.*

It is the prevalence or *predominance* of any parti-  
cular passion which gives the turn or tincture to a

man's temper, by which he is distinguished, and for which he is loved or esteemed, or shunned and despised by others. *Mason.*

**PREEMINENCE**, *n. s.* } *Fr. preeminence;*  
**PREEMINENT**, *adj.* } *Lat. præ and emi-*  
*nence.* It has been written, to avoid the junction of *ee*, preeminence. Excellence; superiority of merit or station: pre-eminent is excellent; superior.

His lance brought him captives to the triumph of *Artesia's* beauty, such as, though *Artesia* be amongst the fairest, yet in that company were to have the preeminency. *Sidney.*

That which standeth on record hath preeminence above that which passeth from hand to hand, and hath no pens but the tongues, no book but the ears of men. *Hooker.*

I do invest you jointly with my power, *Preeminence*, and all the large effects

That troop with majesty. *Shakspeare. King Lear.*

The English desired no preeminence, but offered equality both in liberty and privilege, and in capacity of offices and employments. *Hayward.*

It is a greater preeminence to have life, than to be without it; to have life and sense, than to have life only; to have life sense, and reason, than to have only life and sense. *Wilkins.*

Tell how came I here? by some great maker In goodness and in power preeminent. *Milton.*

Beyond the equator, the southern point of the needle is sovereign, and the north submits his preeminence. *Browne.*

I plead for the preeminence of epick poetry. *Dryden.*

We claim a proper interest above others, in the preeminent rights of the household of faith. *Sprat.*

Am I distinguished from you but by toils,

Superior toils, and heavier weight of cares?

Painful preeminence! *Addison's Cato.*

**PREEMPTION**, *n. s.* *Lat. præemptio.* The right of purchasing before another.

Certain persons, in the reigns of king *Edward VI.* and queen *Mary*, sought to make use of this preemption, but, crossed in the prosecution, or defeated in their expectation, gave it over. *Carew.*

**PREENGAGE**, *v. a.* } *Præ and engage.*

**PREENGAGEMENT**, *n. s.* } To engage by precedent ties or contracts: the noun substantive corresponding.

Men are apt to think that those obediences they pay to God shall, like a preengagement, disannul all after-contracts made by guilt. *Decay of Piety.*

The opinions, suited to their respective tempers, will make way to their assent, in spite of accidental preengagements. *Glanville.*

My preengagements to other themes were not unknown to those for whom I was to write. *Boyle.*

To *Cipseus* by his friends his suit he moved, But he was preengaged by former ties. *Dryden.*

As far as opportunity and former preengagements will give leave. *Collier of Friendship.*

The world has the unhappy advantage of preengaging our passions at a time when we have not reflection enough to look beyond the instrument to the hand whose direction it obeys. *Rogers's Sermons.*

**PREEXIST**, *v. a.* } *Lat. præ and existo.*

**PREEXISTENCE**, *n. s.* } To exist beforehand:  
**PREEXISTENT**, *adj.* } the noun-substantive and adjective corresponding.

If thy preexisting soul.

Was formed at first with myriads more

It did through all the mighty poets toll. *Dryden.*

Wisdom declares her antiquity and preexistence to all the works of this earth. *Burnet.*

Artificial things could not be from eternity, because they suppose man, by whose art they were made preexistent to them; the workman must be before the work. *H.*

As *Simonides* has exposed the vicious part of woman from the doctrine of preexistence; some of the ancient philosophers have satirised the vicious part of the human species, from a notion of the soul's postexistence. *Addison.*

If this preexistent eternity is not compatible with a successive duration, then some being, though infinitely above our finite comprehensions, must have had an identical, invariable continuance from all eternity, which being is no other than God. *Bentley.*

Blind to former, as to future fate,  
 What mortal knows his preexistent state?

*Popr.*

**PRE-EXISTENCE** is a priority of being, or the being of one thing before another. Thus a cause is in nature pre-existent to its effect. The *Peripatetics*, though they maintained the eternity of the world, were likewise dogmatical in their opinion that the universe was formed, actuated, and governed, by a sovereign intelligence. *Mr. Hume's* speculations also, on this abstruse and arduous subject, had a greater tendency to dissipate its gloom than that philosopher himself could imagine. The pre-existence of the human soul to its corporeal vehicle had been from time immemorial a prevailing opinion among the *Asiatic* sages, and from them was perhaps transferred by *Pythagoras* to the philosophy of the *Greeks*; but his metempsychosis is too trivial either to be seriously proposed or refuted. Nevertheless, from the sentiments of *Socrates* concerning the immortality of the soul, delivered in his last interview with his friends, it is obvious that the tenet of pre-existence was a doctrine of the *Platonic* school. But their hypothesis was totally unsupported by fact, except the solitary pretence of *Pythagoras*, that his soul had formerly animated the body of *Euphorbus*; a fable evidently invented to support his doctrine of transmigration. After the *Christian* religion had been considerably diffused, and warmly combated by its philosophical antagonists, the same doctrine was resumed and taught at *Alexandria*, by *Platonic* proselytes, not only as a topic constituent of their master's philosophy, but as an answer to those formidable objections which had been deduced from the doctrine of original sin, and from the vices which stain, and the calamities which disturb human life. For the human beings introduced by them to the theatre of probation had already attained the capacity of moral agents; as their crime therefore was voluntary their punishment might be just.

The word has also been used with regard to the divinity of our Saviour. The *Arians*, who allowed the subordinate divinity of our Saviour, believed him pre-existent to all time, and before all worlds; but the *Socinians*, who esteemed his nature, as well as his person, merely human, insisted that before his incarnation he was only pre-existent in the divine idea, not in nature or person.

**PREFACE**, *n. s.*, *v. n.* & } French *preface* ;  
**PREFACER**, } *[v. a.]* Latin *præfatio*.  
**PREFATORY**, *adj.* } Something intro-  
 ductory to the main design; introduction; to  
 say or introduce something proemial: a prefacer  
 is the author of a preface: prefatory, introduc-  
 tory; preparative.

This superficial tale  
 Is but a *preface* to her worthy praise.  
*Shakspeare.*

Sir Thomas More betrayed his depth of judgment  
 in state affairs in his Utopia, than which, in the opi-  
 nion of Budæus, in a *preface* before it, our age hath  
 not seen a thing more deep.  
*Peucham.*

I love to wear clothes that are flush,  
 Not *prefacing* old rags with plush. *Cleveland.*  
 Heaven's high behest no *preface* needs. *Milton.*  
 Wheresoe'er he gave an admonition, he *prefaced*  
 it always with such demonstrations of tenderness.  
*Fell.*

If there be not a tolerable line in all these six,  
 the *prefacer* gave me no occasion to write better.  
*Dryden.*

If this proposition, whosoever will be saved, be  
 restrained only to those to whom it was intended,  
 the Christians, then the anathema reaches not the  
 heathens, who had never heard of Christ: after all,  
 I am tar from blaming even that *prefatory* addition  
 to the creed. *Id.*

Before I enter upon the particular parts of her  
 character, it is necessary to *preface* that she is the  
 only child of a decrepid father. *Spectator.*

It is lamentable to behold with what lazy scorn  
 many of the yawning readers in our age, now-a-days,  
 travel over forty or fifty pages of *preface* and dedica-  
 tion (the usual modern stunt) as if it were so much  
 Latin. *Swift.*

Thou art rash,  
 And must be *prefaced* into government.  
*Southern.*

**PREFECT**, *n. s.* } Lat. *præfectus*. Govern-  
**PREFECTURE**. } nor; commander: *prefec-*  
 ture is his office or sphere of government.

He is much  
 The better soldier, having been a tribune,  
*Prefect*, lieutenant, prætor in the war.  
*Ben Jonson.*

It was the custom in the Roman empire for the  
*præfects* and viceroys of distant provinces to transmit  
 a relation of every thing remarkable in their admini-  
 stration. *Addison.*

The **PREFECT**, in ancient Rome, was one of  
 the chief magistrates who governed in the ab-  
 sence of the kings, consuls, and emperors. This  
 power was greatest under the emperors. His  
 chief care was the government of the city, taking  
 cognizance of all crimes committed therein, and  
 within 100 miles. He judged capitally and  
 finally, and even presided in the senate. He  
 had the superintendance of the provisions, build-  
 ing, and navigation.

The **PREFECT OF THE PRÆTORIUM** was the  
 leader of the prætorian bands destined for the em-  
 peror's guards, consisting, according to Dion, of  
 100,000 men. This officer, according to Suetonius,  
 was instituted by Augustus, and usually  
 taken from among the knights. By the favor of  
 the emperors his power grew very considerable;  
 to reduce which, Constantine divided the *præfec-*  
*tore* of the prætorium into four prefectures, and  
 each of these again he subdivided into civil and

military departments, the title being reserved to  
 him who was invested with the civil authority,  
 and that of *cesares belli* given him who com-  
 manded the cohorts.

**PREFER**, *v. a.* } Fr. *preferer*; Span.  
**PREFERABLE**, *adj.* } *preferir*; Ital. *pre-*  
**PREFERABLENESS**, *n. s.* } *ferire*; Lat. *præfero*.  
**PREFERABLY**, *adv.* } To regard with su-  
**PREFERENCE**, *n. s.* } perior esteem or at-  
**PREFERMENT**. } tention; taking *above*,

*before*, and *to*, before the object postponed; to  
 advance; exalt; raise; exhibit; offer or propose  
 solemnly: preferable is eligible before some  
 other thing or person; the adverb and noun  
 substantive corresponding: preference is, the act  
 of preferring; electing; esteeming or raising one  
 thing before another: preferment, advancement;  
 promotion; place of honor or advantage; par-  
 ticularly a church living.

If I do not remember thee, let my tongue cleave  
 to the roof of my mouth; if I *prefer* not Jerusalem  
*above* my chief joy. *Psalms.*

He that cometh after me is *preferred* before me,  
 for he was before me. *John i. 15.*

In honour *preferring* one another. *Romans.*  
 I, when my soul began to faint.

My vows and prayers to thee *preferred*:  
 The Lord my passionate complaint,  
 Even from his holy temple, heard. *Sandys.*

It may worthily seem unto you a most shameful  
 thing, to have *preferred* an infamous peace before a  
 most just war. *Knolles.*

I'll move the king  
 To any shape of thy *preferment*, such  
 As thou'lt desire. *Shakspeare. Cymbeline.*  
 They flatly disavouch

To yield him more obedience or support,  
 And as t' a perjured duke of Lancaster,  
 Their cartel of defiance they *prefer*. *Daniel.*

The greater good is to be *preferred* before the less,  
 and the lesser evil to be endured rather than the  
 greater. *Wilkins.*

By the recommendation of the earl of Coventry, he  
 was *preferred* to the bishoprick of Coventry and  
 Litchfield. *Clarendon.*

O spirit, that dost *prefer*  
 Before all temples the' upright heart. *Milton.*

I shall give an account of some of those appro-  
 priate and discriminating notices wherein the human  
 body differs, and hath *preference* above the most per-  
 fect brutal nature. *Hale.*

All which declare a natural *preferment* of the one  
 unto the motion before the other. *Browne.*

Leave the criticks on either side to contend about  
 the *preference* due to this or that sort of poetry.  
*Dryden*

All *preferments* should be placed upon fit men.  
*L'Estrange.*

The stronger ties we have to an unalterable pur-  
 suit of happiness, which is greatest good, the more  
 are we free from any necessary compliance with our  
 desire, set upon any particular, and then appearing  
*preferable* good, till we have duly examined it.  
*Locke.*

We find in ourselves a power to begin or forbear  
 several actions of our minds and motions of our bod-  
 ies, barely by a thought or *preference* of the mind,  
 ordering the doing, or not doing such a particular  
 action. *Id.*

It gives as much due to good works as is con-  
 sistent with the grace of the gospel; it gives as much  
*preference* to divine grace as is consistent with the  
 precepts of the gospel. *Sprat.*

The mercenary and inconstant crew of the hunters *after preferment*, whose designs are always seen through.

*Davenant.*

Almost every man in our nation is a politician, and hath a scheme of his own, which he thinks *preferable* to that of any other.

*Addison.*

The several musical instruments in the hands of the Apollos, Muses, and Fauns, might give light to the dispute for *preference* between the ancient and modern musick.

*Id.*

Every person within the church or commonwealth may *prefer* an accusation, that the delinquent may suffer condign punishment.

*Ayliffe.*

Take care,

Lest thou *prefer* so rash a prayer,

Nor vainly hope the queen of love

Will e'er thy fav'rite's charms improve.

*Prior.*

*Prefer* a bill against all kings and parliaments since the conquest; and, if that won't do, challenge the crown and the two houses.

*Collier.*

Even in such a state as this, the pleasures of virtue would be superior to those of vice, and justly *preferable*.

*Atterbury.*

How came he to chuse a comick *preferably* to the tragick poets; or how comes he to chuse Plautus *preferably* to Terence?

*Dennis.*

The Romanists were used to value the latter equally with the former, or even to give them the *preference*.

*Waterland.*

A secret pleasure touched Athena's soul,

To see the *pref'rence* due to sacred age

Regarded.

*Pope's Odyssey.*

He spake, and to her hand *preferred* the bowl.

*Pope.*

Princes must, by a vigorous exercise of that law, make it every man's interest and honour to cultivate religion and virtue, by rendering vice a disgrace, and the certain ruin to *preferment* or pretensions.

*Swift.*

We know your prudence, Sir William, and I should be sorry to stop your *preferment*.

*Junius.*

PREFIGURATE, or

PREFIGURE, v. a.

PREFIGURATION, n. s.

Lat. *præ* and *figuro*.

To show by antece-

dent representation:

antecedent representation.

What the Old Testament hath, the very same the New containeth; but that which lieth there, as under a shadow, is here brought forth into the open sun; things there *prefigured* are here performed.

*Hooker.*

Such piety, so chaste use of God's day,

That what we turn to feast, she turned to pray,

And did *prefigure* here in devout taste,

The rest of her high sabbath, which shall last.

*Donne.*

If shame superadded to loss, and both met together, as the sinner's portion here, perfectly *prefiguring* the two saddest ingredients in hell, deprivation of the blissful vision, and confusion of face, cannot prove efficacious to the mortifying of vice, the church doth give over the patient.

*Hammond.*

The variety of prophecies and *prefigurations* had their punctual accomplishment in the author of this institution.

*Norris.*

The same providence that hath wrought the one will work the other; the former being pledges, as well as *prefigurations*, of the latter.

*Burnet.*

PREFINE', v. a. Fr. *refinir*; Lat. *præfinio*. To limit beforehand.

He, in his immoderate desires, *prefined* unto himself three years, which the great monarchs of Rome could not perform in so many hundreds.

*Knolles.*

PREFIX', v. a. & n. s. Lat. *præfigo*. To appoint before hand; settle; put before another thing; a thing so fixed: a particle put before a word to vary its signification.

A time *prefix*, and think of me at last.

*Sandys*

At the *prefixed* hour of her awaking,

Came I to take her from her kindred's vault.

*Shakspeare.*

Whose sins

Full weight must be transferred upon my head;

Yet neither thus disheartened or dismayed,

The time *prefixed* I waited.

*Milton.*

Because I would *prefix* some certain boundary between them; the old statutes end with king Edward II, the new or later statutes begin with king Edward III.

*Hale's Law of England.*

It is a *prefix* of augmentation to many words in that language.

*Broune's Vulgar Errors.*

Booth's forward valour only served to show,

He durst that duty pay we all did owe:

The attempt was fair; but heaven's *prefixed* hour

Not come.

*Druden.*

These boundaries of species are as men, and not as nature makes them, if there are in nature any such *prefixed* bounds.

*Locke.*

In the Hebrew language the noun has its *prefixa* and affixa, the former to signify some few relations, and the latter to denote the pronouns possessive and relative.

*Clarke.*

PREFORM', v. a. *Præ* and form. To form beforehand. Not in use.

If you consider the true cause

Why all these things change from their ordinance,

Their natures and *preformed* faculties,

To monstrous quality; why you shall find

That heaven made them instruments of fear

Unto some monstrous state.

*Shakspeare. Julius Cæsar.*

PREG'NANT, adj. } Fr. *pregnant*; Lat.  
PREG'NANTLY, adv. } *pregnans*. Teeming; breeding; fertile; full of meaning; evident; free: the adverb corresponding.

*Pregnancy* is made a tapster, and hath his quick wit wasted in giving reckonings.

*Shakspeare.*

This granted, as it is a most *pregnant* and unforced position, who stands so eminent in the degree of this fortune as Cassio, a knave very voluble.

*Id. Othello.*

Were 't not that we stand up against them all,

'Twere *pregnant*, they should square between themselves.

*Shakspeare.*

A most poor man made tame to fortune's blows,

Who by the art of known and feeling sorrows,

Am *pregnant* to good pity.

*Id. King Lear.*

A thousand moral paintings I can shew,

That shall demonstrate these quick blows of fortune

More *pregnantly* than words.

*Id. Timon.*

He was sent to school, where his *pregnancy* was

advantaged by more than paternal care and industry.

*Fell.*

These knew not the just motives and *pregnant* grounds with which I thought myself furnished.

*King Charles.*

Thou

Dove-like satest brooding on the vast abyss,

And madest it *pregnant*.

*Milton.*

His town, as fame reports, was built of old

By Danae, *pregnant* with almighty gold.

*Druden.*

The breast is encompassed with ribs, and the belly left free for respiration; and, in females, for that extraordinary extension in the time of their *pregnancy*.

*Ray on the Creation*

The dignity of this office among the Jews is so *pregnantly* set forth in holy writ, that it is unquestionable; kings and priests are mentioned together.

South.

Through either ocean, foolish man!  
That *pregnant* word sent forth again,  
Might to a world extend each atom there,  
For every drop call forth a sea, a heaven for every star.

Prior.

An egregious and *pregnant* instance how far virtue surpasses ingenuity. *Woodward's Natural History.*  
O detestable passive obedience! did I ever imagine I should become thy votary in so *pregnant* an instance?

Arbutnot.

This writer, out of the *pregnancy* of his invention, hath found out an old way of insinuating the grossest reflections under the appearance of admonitions.

*Swift's Miscellanies.*

**PREGNANCY. See MIDWIFERY.**

**PREHNITE, or PRISMATIC PREHNITE,** a mineral of which there are two sub-species, the foliated and the fibrous.

1. Foliated. Color apple-green. Massive, in distinct concretions, and sometimes crystallised. Primitive form an oblique four-sided prism of 103° and 77°. Secondary forms, an oblique four-sided table, an irregular eight-sided table, an irregular six-sided table, and a broad rectangular four-sided prism. Shining. Fracture fine grained uneven. Translucent. Hardness from felspar to quartz. Easily frangible. Specific gravity 2.8 to 3.0. It melts with intumescence into a pale-green or yellow glass. It does not gelatinize with acids. Its constituents, according to the analysis of Klaproth, are, silica 43.83, alumina 30.33, lime 18.33, oxide of iron 5.66, water 1.83. It occurs in France, in the Alps of Savoy, and in the Tyrol. It is said to become electric by heating. Beautiful varieties are found in the interior of Southern Africa.

2. Fibrous prehnite. Color light-green. Massive, in distinct concretions, and crystallised in acicular four-sided prisms. Glistening, pearly. Translucent. Easily frangible. Specific gravity 2.89. It melts into a vesicular enamel. It becomes electric by heating. Its constituents, according to Laugier, are, silica 42.5, alumina 28.5, lime 20.44, natron and potash 0.75, oxide of iron 3, water 2. It occurs in veins and cavities in trap-rocks near Beith in Ayrshire, Bishopstoun in Renfrewshire, at Hartfield near Paisley, and near Frisky Hall, Old Kilpatrick; in the trap-rocks round Edinburgh, &c.

**PREJUDGE', v. a.** Fr. *prejurer*; Lat. *pra* and *judico*. To determine beforehand; generally to condemn beforehand.

If he stood upon his own title of the house of Lancaster, he knew it was condemned in parliament, and *prejudged* in the common opinion of the realm, and that it tended to the disinherison of the line of York.

*Bacon's Henry VII.*

The child was strong and able, though born in the eighth month, which the physicians do *prejudge*.

*Bacon.*

The cause is not to be defended, or patronized by names, but arguments, much less to be *prejudged*, or blasted by them.

*Hammond.*

Some action ought to be entered, lest a greater *cause* should be injured and *prejudged* thereby.

*Ayliffe.*

The committee of council hath *prejudged* the whole case, by calling the united sense of both houses of parliament an universal clamour.

*Swift.*

**PREJUDICATE, v. a. & adj.** } Also of Lat.  
**PREJUDICATION, n. s.** } *pra* and *judico*.  
To determine beforehand to disadvantage: *prejudged*: the art of prejudging.

Are you, in favour of his person, bent  
Thus to *prejudicate* the innocent?

*Sandys*

Our dearest friend

*Prejudicates* the business, and would seem

To have us make denial.

*Shakespeare.*

Their works will be embraced by most that understand them, and their reasons enforce belief from *prejudicate* readers.

*Browne.*

This rule, of casting away all our former *prejudicate* opinions, is not proposed to any of us to be practised at once as subjects or Christians, but merely as philosophers.

*Waitt.*

**PREJUDICE, n. s. & v. a.** } Fr. *prejudico*;  
**PREJUDICIAL, adj.** } Lat. *prejudicium*.

Prepossession; judgment formed without examination; used for prepossession either in favor of any thing or against it; and sometimes (but not properly) with *to* before that which the *prejudice* is against; mischief; hurt; detriment: *to* *prejudice* is to fill with unexamined notions or opinions; to obstruct; to injure; hurt: *prejudicial*, obstructed; or possessed by opposite opinions; contrary; opposite; hurtful.

The strength of that law is such, that no particular nation can lawfully *prejudice* the same by any their several laws and ordinances, more than a man, by his private resolutions, the law of the whole commonwealth wherein he liveth.

*Hooker.*

What one syllable is there, in all this, *prejudicial* any way to that we hold?

*Id.*

Neither must his example, done without the book, *prejudice* that which is well appointed in the book.

*Whitgift.*

I have not spoke one the least word,

That might be *prejudice* of her present state,

Or touch of her good person.

*Shakespeare. Henry VIII.*

Factions carried too high and too violently, is a sign of weakness in princes, and much to the *prejudice* of their authority and business.

*Bacon.*

'Tis a sad irreverence, without due consideration, to look upon the actions of princes with a *prejudicial* eye.

*Holyday.*

The king himself frequently considered more the person who spoke, as he was in his *prejudice*, than the council itself that was given.

*Clarendon.*

His going away the next morning with all his troops was most *prejudicial* and most ruinous to the king's affairs.

*Id.*

My comfort is, that their manifest *prejudice* to my cause will render their judgment of less authority.

*Dryden.*

How plain this abuse is, and what *prejudice* it does to the understanding of the sacred scriptures.

*Locke.*

A prince of this character will instruct us by his example, to fix the unsteadiness of our politics; or by his conduct hinder it from doing us any *prejudice*.

*Adams.*

One of the young ladies reads while the others are at work; so that the learning of the family is not at any *prejudicial* to its manufactures.

*Id.*

Half pillars wanted their expected height,

And roofs imperfect *prejudiced* the sight.

*Prior.*

A state of great prosperity, as it exposes us to va-



ious temptations, so it is often *prejudicial* to us, in that it swells the mind with undue thoughts.

*Atterbury.*

Suffer not any beloved study to *prejudge* your mind, so far as to despise all other learning.

*Watts.*

To this is added a vinous bitter, warmer in the composition of its ingredients than the watery infusion; and, as gentian and lemon-peel make a bitter of so grateful a flavour, the only care required in this composition was to chuse such an addition as might not *prejudge* it.

*London Dispensatory.*

By these a man's judgment is easily perverted, and a wrong bias hung upon his mind; these are the inlets of *prejudice*; the unguarded avenues of the mind.

*Mason.*

The truth is, if the truth may suit your ear,  
And *prejudice* have left a passage clear,  
Pride has attained its most luxuriant growth,  
And poisoned every virtue in them both.

*Cowper.*

**PRELATE, n. s.** } Fr. *prelat*; Lat. *præ-*  
**PRELAT'ICAL.** } *tus*. An ecclesiastic of  
the highest order: relating to prelacy.

Divers of the reverend *prelacy*, and other most judicious men, have especially bestowed their pains about the matter of jurisdiction.

*Hooker's Dedication.*

It beseeemed not the person of so grave a *prelate*, to be either utterly without counsel, as the rest were, or in a common perplexity to shew himself alone secure.

*Hooker.*

Hear him but reason in divinity,  
And, all-admiring, with an inward wish  
You would desire the king were made a *prelate*.

*Shakspeare.*

The archbishop of Vienna, a reverend *prelate*, said one day to king Lewis XI. of France: Sir, your mortal enemy is dead, what time duke Charles of Burgundy was slain.

*Bacon.*

The presbyter, puff'd up with spiritual pride,  
Shall on the necks of the lewd nobles ride,  
His brethren damn, the civil power defy,  
And parcel out republic *prelacy*.

*Dryden.*

Yet Munster's *prelate* ever be accurst,

In whom we seek the German faith in vain. *Id.*

*Prelacies* may be termed the greater benefices; as that of the pontificate, a patriarship, an archbishoprick and bishoprick.

*Auliffe's Parergon.*

How many are there, that call themselves protestants, who put *prelacy* and popery together as terms convertible!

*Swift.*

The king then wrote a letter to the bishop, in which he complained of the violation of his rights, and the contempt of his authority, charged the *prelate* with countenancing the late act of disobedience, and required an answer in two days.

*Johnson.*

**PRELATION, n. s.** Lat. *prælatus*. Preference: setting of one above the other.

In case the father left only daughters, they equally succeeded as in co-partnership, without any *prelation* or preference of the eldest daughter to a double portion.

*Hale.*

**PRELECTION, n. s.** Lat. *prælectio*. Reading; lecture; discourse.

He that is desirous to prosecute these asystata, or infinitude, let him resort to the *prelections* of

*Faber.*  
*Hale.*

**PRELIBATION, n. s.** Lat. *prælibo*. Taste beforehand; effusion previous to tasting.

The firm belief of this, in an innocent soul, is a high *prelibation* of those eternal joys.

*More.*

**PRELIMINARY, adj. & n. s.** Fr. *preliminaire*; Lat. *prælimine*. Previous; introductory; proemial: something introductory; previous condition or stipulation.

My master needed not the assistance of that *preliminary* poet to prove his claim; his own majestic mien discovers him to be the king.

*Dryden.*

The third consists of the ceremonies of the oath on both sides, and the *preliminaries* to the combat.

*Notes on Iliad.*

**PRELUDE, n. s. & v. a.** } French *prelude*;  
**PRELUDIOUS, adj.** } Latin *præliudium*.

**PRELUDIUM, n. s.** } A short piece of music played before a full concert; anything introductory; to serve as an introduction: *preludious* is previous; introductory: *preludium*, a *prelude*.

That's but a *preludious* bliss,

Two souls pickering in a kiss. *Cleaveland.*

To his infant arms oppose

His father's rebels and his brother's foes;

Those were the *preludes* of his fate,

That formed his manhood, to subdue

The hydra of the many-headed hissing crew.

*Dryden.*

Either songster holding out their throats,  
And folding up their wings, renew'd their notes,  
As if all day, *preluding* to the fight,  
They only had rehears'd, to sing by night. *Id.*

This Menelaus knows, exposed to share

With me the rough *preludium* of the war. *Id.*

The last Georgick was a good *prelude* to the Æneis, and very well shewed what the poet could do in the description of what was really great.

*Addison.*

One concession to a man is but a *prelude* to another.

*Clarissa.*

My weak essay

But sounds a *prelude*, and points out their prey.

*Young.*

**PRELUSIVE, adj.** From *prelude*. Previous; introductory; proemial.

The clouds

Softly shaking on the dimpled pond

*Prelusives* drops, let all their moisture flow.

*Thomson.*

**PREMATURE, adj.** Fr. *prematüre*; Lat. *præmaturus*. Precocious; ripe too soon; formed before the time; too early.

'Tis hard to imagine, what possible consideration should persuade him to repent, till he deposited that *premature* persuasion of his being in Christ.

*Hammond's Fundamentals.*

**PREMEDITATE, v. a. & v. n.** } Fr. *pre-*

**PREMEDITATION, n. s.** } *mediter*;

Lat. *præmeditor*. To contrive; form or conceive beforehand: to think beforehand: *premeditation*, forethought; act of meditating beforehand.

Of themselves they were rude, and knew not so much as how to *premeditate*; the spirit gave them speech and eloquent utterance.

*Hooker.*

Where I have come, great clerks have purposed  
To greet me with *premeditated* welcomes.

*Shakspeare.*

Are all th' unlooked-for issue of their bodies

To take their rooms ere I can place myself?

A cold *premeditation* for my purpose!

*Id.*

Hope is a pleasant *premeditation* of enjoyment, as when a dog expects, till his master has done picking of the bone.

*More.*

He, amidst the disadvantage of extempore against *premeditation*, dispelled with ease and perfect clear-

ness all the sophisms that had been brought against him. *Fell.*

With words *premeditated* thus he said. *Dryden.*

Verse is not the effect of sudden thought; but this hinders not that sudden thought may be represented in verse, since those thoughts must be higher than nature can raise without *premeditation*.

*Id. on Dramatic Poetry.*

**PREMERIT**, *v. a.* Lat. *præmereor*. To deserve before.

They did not forgive Sir John Hotham, who had so much *premerited* of them. *King Charles.*

**PREMICES**, *n. s.* Fr. *premices*; Lat. *primitiæ*. First fruits.

A charger, yearly filled with fruits, was offered to the gods at their festivals, as the *premites* or first gatherings. *Dryden.*

**PREMIER**, *adj. & n. s.* Fr. *premier*. First; chief: a chief minister of state.

The Spaniard challengeth the *premier* place, in regard of his dominions. *Camden's Remains.*

Thus families, like realms, with equal fate, Are sunk by *premier* ministers of state. *Swift.*

**PREMISE**, *v. a.* } Lat. *præmissus*. To explain previously; lay down premises; which are propositions antecedently supposed or proved: *premiss* is the singular, and rarely used; *premites* or *premisses*, in law, properly signifies the land, &c., mentioned in the beginning of a deed; hence it came to mean in law language, house and lands.

They infer upon the *premisses*, that as great difference as commodiously may be, there should be in all outward ceremonies between the people of God, and them which are not his people. *Hooker.*

O let the vile world end,

And the *premiss'd* flames of the last day  
Knit earth and heaven together. *Shakspeare.*

This is so regular an inference, that, whilst the *premisses* stand firm, it is impossible to shake the conclusion. *Decay of Piety.*

The apostle's discourse here is an answer upon a ground taken; he *premisseth*, and then infers.

*Burnet.*

I *premiss* these particulars, that the reader may know I enter upon it as a very ungrateful task. *Addison.*

She studied well the point, and found

Her foes' conclusions were not sound,

From *premisses* erroneous brought,

And therefore the deductions nought. *Swift's Miscellanies.*

They know the major or minor, which is implied, when you pronounce the other *premiss* and the conclusion. *Watts.*

**PREMIUM**, *n. s.* Lat. *præmium*. Something given to invite a loan or a bargain.

No body cares to make loans upon a new project; whereas men never fail to bring in their money upon a land tax, when the *premium* or interest allowed them is suited to the hazard they run. *Addison's Freeholder.*

People were tempted to lend, by great *premiums* and large interest; and it concerned them to preserve that government, which they had trusted with their money. *Swift's Miscellanies.*

**PREMNA**, in botany, a genus of the angiospermia order, and didymia class of plants: cal. bilobed: cor. quadrifid: berry quadrilocular:

Vot. XVIII.

**SEEDS** solitary. Species three, fine East India trees.

**PREMON'ISH**, *v. a.* Lat. *præmoneo*. To warn or admonish beforehand.

What friendly *premonitions* have been spent  
On your forbearance, and their vain event. *Chapman.*

After these *premonishments*, I will come to the compartion itself. *Wotton's Architecture.*

How great the force of such an erroneous persuasion is, we may collect from our Saviour's *premonition* to his disciples, when he tells them that those who killed them should think they did God service. *Decay of Piety.*

It is no small mercy of God, that he gives us warning of our end. We shall make an ill use of so gracious a *premonition*, if we make not a meet preparation for our passage. *Bp. Hall.*

**PREMONSTRANTS**, or **PRÆMONSTRATENSES**, a religious order of regular canons, instituted in 1120, by St. Norbert; and thence also called Norbertines. The first monastery of this order was built by Norbert in the Isle of France, which he called Premonstre, Præmonstratum; and hence the order derived its name; though, as to the occasion of that name, the writers of that order are divided. At first the religious of this order were so very poor that they had only a single ass, which served to carry the wood they cut down every morning, and sent to Laon in order to purchase bread. But they soon received so many donations, and built so many monasteries, that in thirty years after the foundation of the order they had above 100 abbeys in France and Germany; and, in process of time, the order so increased that it had monasteries in all parts of Christendom, amounting to 1000 abbeys, 300 provostships, a vast number of priories, and 500 nunneries. The rule they followed was that of St. Augustine, with some slight alterations, and an addition of certain severe laws, whose authority did not long survive their founder. The order was approved by Honorius II. in 1126, and afterwards by several succeeding popes. At first the abstinence from flesh was rigidly observed. In 1245 Innocent IV. complained to a general chapter of its being neglected. In 1288 their general, William, procured leave of pope Nicholas IV. for those of the order to eat flesh on journeys. In 1460 Pius II. granted them a general permission to eat meat, excepting from Septuagesima to Easter. The dress of the religious of this order is white, with a scapulary before the cassock. Out of doors they wear a white cloak and white hat; within, a little camail; and at church a surplice, &c. In the first monasteries built by Norbert there was one for men and another for women, only separated by a wall. In 1137, by a decree of a general chapter, this practice was prohibited, and the nuns removed out of those already built to a greater distance from those of the monks. The Præmonstratenses, or monks of Premontré, vulgarly called white canons, came first into England A. D. 1146. Their first monastery, called New House, was erected in Lincolnshire by Peter de Saulia, and dedicated to St. Martial. In the reign of Edward I. this order had twenty-seven monasteries in England.

E

**PREMONTVAL** (Peter Le Guay de), an eminent French writer, born at Charenton in 1716. He became a member of the academy of Berlin. He wrote several works, of which the most noted is his *Antidote to the Corruption of the French Language*, written in German. He died at Berlin in 1767, aged fifty-one.

**PREMUNIRE**, *n. s.* Lat. *premunire*. A writ in common law, whereby a penalty is incurable, as infringing some statute. See below.

*Premunire* is now grown a good word in our English laws, by tract of time; and yet at first it was merely mistaken for *premonire*.

*Branhall against Hobbes.*

Wolsey incurred a *premunire*, forfeited his honour, estate, and life, which he ended in great calamity.

*South.*

**PREMUNIRE**. See **PRÆMUNIRE**.

**PRENANTHES**, in botany, wild lettuce, a genus of the polygamia æqualis order, and syngenesia class of plants; natural order forty-ninth, compositæ: receptacle naked: CAL. calyculated: pappus simple, and almost sessile: the florets are placed in a single series. Species thirty-three; one, *P. mutalis*, common to our own groves.

**PRENOMINATE**, *v. a.* Latin *prænomino*. To forename.

He you would sound,

Having ever seen, in the *prenominate* crimes,

The youth, you breathe of, guilty. *Shakspeare.*

The watery productions should have the *prænomination*; and they of the land rather derive their names, than nominate those of the sea. *Broune.*

**PRENOTION**, *n. s.* Fr. *prenotion*; Lat. *præ* and *nosco*. Foreknowledge; prescience.

The hedgehog's presension of winds is so exact, that it stoppeth the north or southern hole of its nest, according unto *prenotion* of these winds ensuing. *Broune.*

**PRENTICE**, *n. s.* } Contracted from AP-  
**PRENTICESHIP**. } **PRENTICE**. One bound to a master, in order to instruction in a trade: state or servitude of an apprentice.

My accuser is my *prentice*, and, when I did correct him for his fault, he did vow upon his knees he would be even with me. *Shakspeare.*

He served a *prenticeship*, who sets up shop, Ward tried on puppies, and the poor, his drop.

*Pope.*

**PRENZLOW**, the chief town of the district of Brandenburgh, called the Ucker Mark, Prussia. It is situated in a plain on the lake and river Ucker, and is divided into the Old and New Town; both of which are tolerably built. Here are four Lutheran, two Calvinist, and one Catholic church; a pleasant square, a beautiful public walk, several schools and hospitals, and 8000 inhabitants. The town has also several breweries, and a considerable trade in corn. The woollen manufactures, and still more those of tobacco, occupy a large portion of the inhabitants, many of whom are descended from French Protestant refugees. It was near this place, on 24th October 1806, that the remains of the Prussian army, about 20,000, defeated at Jena on the 14th, were obliged to surrender to the French. Seventy-three miles N. N. W. of Frankfort on the Oder, and fifty-six N. N. E. of Berlin.

**PREOCUPATE**, *v. a.* } Fr. *preoccuper*;

**PREOCCUPATION**, *n. s.* } Lat. *præoccupo*. To

**PREOCCUPY**, *v. a.* } anticipate; prepos-

sess; fill with prejudice: *preoccupation* corresponds with these senses: to preoccupy is the more modern synonyme of preoccupate.

Honour aspireth to death; grief flieth to it; and fear *preoccupieth* it. *Bacon.*

That the model be plain without colours, lest the eye *preoccupate* the judgment. *Watton.*

As if, by way of *preoccupation*, he should have said; well, here you see your commission, this is your duty, these are your discouragements; never seek for evasions from worldly afflictions; this is your reward, if you perform it; this is your doom, if you decline it. *South.*

I think it more respectful to the reader to leave something to reflections, than *preoccupy* his judgment. *Arbutnot.*

**PREOMINATE**, *v. a.* Lat. *præ* and *ominor*. To prognosticate; to show by omens any future event.

Because many ravens were seen when Alexander entered Babylon, they were thought to *preominate* his death. *Broune.*

**PREOPINION**, *n. s.* Lat. *præ* and *opinio*. Opinion antecedently formed; prepossession.

Diet holds no solid rule of selection; some, in indistinct voracity, eating almost any; others, out of a timorous *preopinion*, refraining from very many things. *Broune.*

**PREORDAIN'**, *v. a.* } Lat. *præ* and *ordain*.

**PREOR'DINANCE**, *n. s.* } To ordain beforehand: antecedent decree.

These lowly courtesies  
Might stir the blood of ordinary men,  
And turn *preordainance* and first decree  
Into the law of children.

*Shakspeare. Julius Cæsar.*

Sin is the contrariety to the will of God, and if all things be *preordained* by God, and so demonstrated to be willed by him, it remains there is no such thing as sin. *Hammond.*

Few souls *preordained* by fate,  
The race of gods, have reached that envied state.

*Roscommon.*

**PREPARE'**, *v. a., v. n. & n. s.* } Fr. *preparer*;

**PREPARATION**, *n. s.* } It. *preparare*;

**PREPARATIVE**, *adj. & n. s.* } Lat. *præparo*.

**PREPARATIVELY**, *adv.* } To fit, qualify,

**PREPARATORY**, *adj.* } or make ready

**PREPAR'EDLY**, *adv.* } for any purpose;

**PREPAR'EDNESS**, *n. s.* } make

**PREPAR'ER**. } ready before-

hand; form; adjust; compound: as a verb neuter, to take previous or preparatory measures; make every thing ready: Shakspeare uses *prepare* for *preparation*; which signifies the act of preparing or previously fitting or ordering things; previous measures; introduction; composition; and, in an obsolete sense, accomplishments; qualification: *preparative* is, having the power or quality of preparing: and, as a noun substantive, that which has this power; that which is done as introductory to something else; the adverb corresponding with the adjective: *preparatory* is, introductory; antecedent; necessary; previous: *preparedly* is, advisedly; orderly; by proper precedent measures: the noun substantive corresponding: *preparer*, he or that which fits or prepares.

There he maketh the hungry to dwell, that they may *prepare* a city for habitation. *Psalm cviii. 35.*

When he prepared the heavens I was there, when he set a compass upon the face of the depth.

*Prov. viii. 27.*

The long suffering of God waited in the days of Noah, while the ark was a preparing.

*1 Peter.*

They tell us the profit of reading is singular, in that it serveth for a preparative unto sermons.

*Hooker.*

I make bold to press, with so little preparation, upon you.

—You're welcome.

*Shakespeare. Merry Wives of Windsor.*

Sir John, you are a gentleman of excellent breeding, authentick in your place and person, generally allowed for your many warlike, courtlike, and learned preparations.

*Shakespeare.*

Patient Octavia, plough thy visage up With her prepared nails.

*Id. Antony and Cleopatra.*

Go in, sirrah, bid them prepare for dinner.

*Shakespeare.*

In our behalf

Go levy men, and make prepare for war.

*Id.*

She preparedly may frame herself

T' the way she's forced to.

*Id. Antony and Cleopatra.*

My book of advancement of learning may be some preparative or key for the better opening of the instauration.

*Bacon.*

The bishop of Ely, the fittest preparer of her mind to receive such a doleful accident, came to visit her.

*Wotton.*

Efficacy is a power of speech, which represents to our minds the lively ideas of things so truly, as if we saw them with our eyes; as Dido preparing to kill herself.

*Peacham.*

The miseries, which have ensued, may be yet, through thy mercy, preparatives to us of future blessings.

*King Charles.*

Resolvedness in sin can, with no reason, be imagined a preparative to remission.

*Decay of Piety.*

Prepares men's hearts by giving them the grace of humility, repentance, and probity of heart.

*Hammond.*

He took the golden compasses, prepared

In God's eternal store, to circumscribe

This universe.

*Milton.*

It is preparatively necessary to many useful things in this life, as to make a man a good physician.

*Hale.*

Preparatory, limited, and formal interrogatories in writing preclude this way of occasional interrogatories.

*Id.*

I wish the chymists had been more sparing, who magnify their preparations, inveigle the curiosity of many, and delude the security of most.

*Browne's Vulgar Errours.*

Though he judged the time of sickness an improper season for the great work of repentance; yet he esteemed it a most useful preparative, the voice of God himself exhorting to it.

*Fell.*

The practice of all these is proper to our condition in this world, and preparatory to our happiness in the best.

*Tillotson.*

What avails it to make all the necessary preparations for our voyage, if we do not actually begin the journey?

*Dryden.*

Confound the peace established, and prepare Their souls to hatred, and their hands to war.

*Id.*

Codded grains are an improver of land, and preparative of it for other crops.

*Mortimer's Husbandry.*

I will shew what preparations there were in nature for this dissolution, and after what manner it came to pass.

*Burnet.*

Rains were but preparatory, the violence of the

deluge depended upon the disruption of the great abyss.

*Id.*

Such a temper is a contradiction to repentance, as being founded in the destruction of those qualities which are the only dispositions and preparatives to it.

*South.*

Some preachers, being prepared only upon two or three points of doctrine, run the same round.

*Addison.*

The beams of light had been in vain displayed, Had not the eye been fit for vision made; In vain the author had the eye prepared With so much skill, had not the light appeared.

*Blackmore.*

In the preparations of cookery, the most volatile parts of vegetables are destroyed.

*Arbuthnot.*

Nothing hath proved more fatal to that due preparation for another life, than our unhappy mistake of the nature and end of this.

*Wake.*

PREPARATION OF DISSONANCES, in music. See MUSIC.

PREPARATIONS, in anatomy, the parts of animal bodies prepared and preserved for anatomical uses. Though several parts prepared dry are useful, yet others must be so managed as to be always flexible, and nearer a natural state. According to Dr. Monro, the best liquor for this purpose is a well rectified colorless spirit of wine, to which is added a small quantity of nitric or sulphuric acids. When these are properly mixed, they neither change the color nor the consistence of their parts, except where there are serous or mucous liquors contained in them. The brain, even of a young child, in this mixture grows so firm as to admit of gentle handling, as do also the vitreous and crystalline humors of the eye. The liquor of the sebaceous glands is coagulated by this spirituous mixture; and it heightens the red color of the injection of the blood-vessels, so that, after the part has been in it a little time, several vessels appear which were before invisible. The glasses which contain the preparations should be of the finest sort, and pretty thick; for through such the parts may be seen very distinctly, and of a true color, and the object will be so magnified as to show vessels in the glass which out of it were not to be seen. As the glass when filled with the liquor has a certain focus, it is necessary to keep the preparation at a proper distance from the sides of it, which is easily done by little sticks suitably placed, or by suspending it by a thread in a proper situation. Mr. Sheldon describes a simple method of stopping the mouths of the preparation glasses, by which means the stopper is rendered nearly as durable as the glass itself. To execute it, let the anatomist take care to have the upper surface of his bottles made plane, by desiring the workmen at the glass-house to flatten them in the making. This they will easily do in forming the round ones, but the flat bottles are attended with considerable difficulty. The right way to make them, would be to blow them in moulds of various sizes; the workmen should likewise form the bottoms of the bottles perfectly flat, that they may stand upright and steady. Bottles of this form being provided for the larger preparations, we grind the upper surface of them on a plain plate of lead, about a quarter of an inch thick, and two feet in diame-

E 2

ter; first with fine emery and water, then with powdered rotten stone, or putty first wet with water and at last dry; so that the surface may be reduced to an exact horizontal plane, and of as fine a polish as plate glass. The manœuvre requires but little dexterity; and the anatomist should be provided with a considerable number of these glasses thus prepared. To the top of each bottle a piece of plate glass, cut by a diamond, is to be adapted so as completely to cover, but not project over, the edge of the bottle. When these two smooth surfaces are put upon each other, with a drop of solution of gum between, the attraction of cohesion is so considerable that it requires great force to separate them. A piece of wet ox bladder, freed from fat, and soaked in water till it becomes mucilaginous, is then to be placed over the top, the air pressed out from between it and the glass; after which it must be tied with a pack-thread dipped in the solution of gum arabic. The bladder, being cut off neatly under the last turn of the thread, is then to be dried, the string taken cautiously off, and the top and neck painted with a composition of lamp-black mixed with japanner's gold size: this soon dries, and leaves a fine smooth glossy surface, from which the dirt can at any time be as readily wiped off as from a mirror. By this method large bottles are as easily and effectually secured as small ones; and it is found to answer as well as the hermetical sealing of glasses, which in large vessels is altogether impracticable. With respect to the stopper bottles, which are very convenient for holding small preparations, Mr. S. advises the stoppers to be perfectly well ground; that they pass rather lower down than the neck of the bottle, for the convenience of drilling two holes obliquely through the inferior edge of the substance of the stopper, opposite to each other, for the convenience of fixing threads to hold the subject; for, if the threads pass between the neck and stopper, a space will be left; or, if the stopper be well ground, the neck of the bottle will be broken in endeavouring to press it down. On the other hand, if any space be left, the thread, by its capillary attraction, will act from capillary attraction, raise the spirits from the bottle, and cause evaporation, which will likewise take place from the chink between the stopper and neck. Mr. W. Cooke has found that all preparations of animal bodies may be preserved by a solution of common salt. He finds that if used a little below saturation, it will preserve animal substances for an indefinite period, at all the temperatures of our atmosphere.—Transactions of the Society of Arts, vol. xxxvii. p. 43.

PREPARIS, the most northern of the Andaman Islands, in the eastern entrance of the Bay of Bengal, about a degree south of the Pegue shore, is four miles long, by one and a half broad. It rises gradually towards the middle, and is covered entirely with wood. In clear weather it may be seen at the distance of twenty-five miles, but can only be approached on the east side, on account of rocks; on that side, within half a mile of the shore, there is seven fathoms water. It is only inhabited by birds, squirrels, and monkeys. Long. 93° 40' E., lat. 14° 50' N.

PREPONDER, *v. a.* } Lat. *præpondero*.  
 PREPONDERANCE, or } To outweigh; over-  
 PREPONDERANCY, *n. s.* } power by weight or  
 PREPONDERATE, } influence: the noun  
 PREPONDERATION. } substantive corre-  
 sponding.

Though pillars by channelling be seemingly ingressed to our sight, yet they are truly weakened; and therefore ought not to be the more slender, but the more corpulent unless appearances *preponder* truths. *Wotton's Architecture.*

A solid verity in one month, is worthy to *preponderate* light falsehood in a thousand. *Bp. Hall.*

That is no just balance, wherein the heaviest side will not *preponderate*. *Wilkins.*

An inconsiderable weight, by distance from the centre of the balance, will *preponderate* greater magnitudes. *Glancille.*

As to addition of ponderosity in dead bodies, comparing them unto blocks, this occasional *preponderancy* is rather an appearance than reality. *Bronne's Vulgar Errors.*

He that would make the lighter scale *preponderate*, will not so soon do it, by adding new weight to the emptier, as if he took out of the heavier, what he adds to the lighter. *Locke.*

The mind should examine all the grounds of probability, and, upon a due balancing the whole, reject or receive proportionably to the *preponderancy* of the greater grounds of probability. *Id.*

Little light boats were the ships which people used, to the sides whereof this fish remora fastening, might make it swag, as the least *preponderance* on either side will do, and so retard its course. *Grew.*

The triviallest thing, when a passion is cast into the scale with it, *preponderates* substantial blessings. *Government of the Tongue.*

Unless the very mathematical centre of gravity of every system be fixed in the very mathematical centre of the attractive power of all the rest, they cannot be evenly attracted on all sides, but must *preponderate* some way or other. *Bentley.*

In matters, which require present practice, we must content ourselves with a mere *preponderation* of probable reasons. *Watts.*

PREPOSITION, *n. s.* Fr. *preposition*; Lat. *prepositio*. In grammar, a particle governing a case.

A *preposition* signifies some relation, which the thing signified by the word following it, has to something going before in the discourse; as, *Cæsar came to Rome.* *Clarke's Latin Grammar.*

PREPOSSESS', *v. a.* *Præ* and *possess*. To possess with an opinion unexamined; to prejudice.

God hath taken care to anticipate and prevent every man to give piety the *prepossession*, before other competitors should be able to pretend to him; and so to engage him in holiness first, and then in bliss. *Hammond's Fundamentals.*

Had the poor vulgar rout only, who were held under the prejudices and *prepossessions* of education, been abused into such idolatrous superstitions, it might have been pitied, but not so much wondered at. *South.*

With thought, from *prepossession* free, reflect  
 On solar rays, as they the sight respect. *Blackmore.*  
 She was *prepossessed* with the scandal of salivating  
*Wiseman.*

PREPOSTEROUS, *adj.* } Latin *præpostere*.  
 PREPOSTEROUSLY, *adv.* } rus. Strictly,  
 PREPOSTEROUNESS, *n. s.* } having that first

which ought to be last : hence, absurdly wrong ;  
 inverted ; the adverb and noun-substantive cor-  
 responding.

*Preposterous* ass ! that never read so far  
 To know the cause why musick was ordained.  
*Shakespeare.*

Those things do best please me,  
 That befall *preposterously*.

*Id. Midsummer Night's Dream.*

Put a case of a land of Amazons, where the whole  
 government, public and private, is in the hands of  
 women : is not such a *preposterous* government  
 against the first order of nature, for women to rule  
 over men, and in itself void ?  
*Bacon.*

Death from a father's hand, from whom I first  
 Received a being ! 'tis a *preposterous* gift,  
 An act at which inverted nature starts,  
 And blushes to behold herself so cruel.  
*Denham.*

The Roman missionaries gave their liberal contri-  
 bution, affording their *preposterous* charity to make  
 them proselytes, who had no mind to be confessors  
 or martyrs.  
*Fell.*

The method I take may be censured as *preposterous*,  
 because I thus treat last of the antediluvian earth,  
 which was first in order of nature.

*Woodward's Natural History.*

Upon this supposition, one animal would have its  
 legs where another hath its liver, and all the other  
 members *preposterously* placed ; there could not be a  
 due configuration of parts in any two individuals.

*Bentley's Sermons.*

The shapeless pair,  
 As they designed to mock me, at my side  
 Take step for step ; and, as I near approach  
 The cottage, walk along the plastered wall,  
*Preposterous* sight ! the legs without the man.  
*Cowper.*

**PREPOTENCY**, *n. s.* Lat. *prepotentia*.  
 Predominance ; superior power.

If there were a determinate *prepotency* in the right,  
 and such as ariseth from a constant root in nature,  
 we might expect the same in other animals.  
*Browne.*

**PREPUCE**, *n. s.* Fr. *prepuce* ; Lat. *pra-*  
*pucium*. That which covers the glans ; foreskin.

The *prepuce* was much inflamed and swelled.  
*Wiseman.*

**PREPUCE.** See ANATOMY.

**PRERAU**, a circle comprising the north-east  
 portion of Moravia, bordering on Austrian Sile-  
 sia. Its area is 1210 square miles. The smaller  
 part lying on the rivers March and Hanna, is  
 fertile ; the rest is mountainous and containing  
 only here and there fruitful spots. The pastures  
 are good, and the number of sheep considerable.  
 The chief rivers are the March, Hanna, Becswa,  
 and Oder, which has here the commencement of  
 its course. Population 215,000. The chief town  
 of the same name is situated thirteen miles south-  
 east of Almutz and contains 2300 inhabitants.

**PREREQUIRE**, *v. a.* } *Præ* and require.

**PREREQUISITE**, *adj.* } To demand pre-  
 viously : *præ* and requisite. Something pre-  
 viously necessary.

Some primary literal signification is *prerequisite* to  
 that other of figurative.  
*Hammond.*

Before the existence of compounded body, there  
 must be a pre-existence of active principles, neces-  
 sarily *prerequisite* to the mixing these particles of bod-  
 ies.  
*Hale.*

The conformation of parts is necessary, not only

unto the *prerequisite* and previous conditions of birth,  
 but also unto the parturition.  
*Browne.*

**PREROGATIVE**, *n. s.* } Fr. *prerogatif* ;  
**PREROGATIVED**, *adj.* } low Lat. *præroga-*  
*tiva*. An exclusive or peculiar privilege ; hav-  
 ing exclusive privilege.

My daughters and the fair Parthenia might far  
 better put in their claim for that *prerogative*.

*Sidney.*

The great caliph hath an old *prerogative* in the  
 choice and confirmation of the kings of Assyria.

*Knolles.*

How could communities,  
 The primogeniture, and due of birth,  
*Prerogative* of age, sceptres, and crowns,  
 But by degree, stand in authentick place ?

*Shakespeare.*

'Tis the plague of great ones,  
*Prerogated* are they less than the base ;  
 'Tis destiny unshunnable.

*Id.*

Had any of these second causes despoiled God of  
 his *prerogative*, or had God himself constrained the  
 mind and will of man to impious acts by any cele-  
 stial enforcements ?

*Haleigh.*

They are the best laws, by which the king hath the  
 justest *prerogative*, and the people the best liberty.

*Bacon.*

They obtained another royal *prerogative* and  
 power, to make war and place at their pleasure.

*Davies.*

The house of commons, to these their *prerogatives*  
 over the lords, sent an order to the lieutenant of the  
 Tower, that he should cause him to be executed that  
 very day.

*Clarendon.*

For freedom still maintained alive,  
 Freedom an English subject's sole *prerogative*,  
 Accept our pious praise.

*Dryden.*

It seems to be the *prerogative* of human under-  
 standing, when it has distinguished any ideas, so as  
 to perceive them to be different, to consider in what  
 circumstances they are capable to be compared.

*Locke.*

I will not consider only the *prerogatives* of man  
 above other animals, but the endowments which na-  
 ture hath conferred on his body in common with them.

*Ray on the Creation.*

**PREROGATIVE COURT**, an English court es-  
 tablished for the trial of all testamentary causes,  
 where the deceased has left bona notabilia within  
 two different dioceses. In which case the pro-  
 bate of wills belongs to the archbishop of the  
 province, by way of special prerogative. And all  
 causes relating to the wills, administrations, or  
 legacies of such persons, are originally cogniza-  
 ble herein, before a judge appointed by the  
 archbishop, called the judge of the prerogative  
 court ; from whom an appeal lies, by stat. 25  
 Hen. VIII. c. 19, to the king in chancery, in-  
 stead of the pope as formerly.

**PREROGATIVE, ROYAL**, that special pre-emi-  
 nence which the king hath over and above all  
 other persons, and out of the ordinary course of  
 the common law, in right of his regal dignity. It  
 signifies in its etymology (from *præ* and *rogō*)  
 something that is required or demanded before,  
 or in preference to all others. And therefore  
 Finch lays it down as a maxim, that the prerog-  
 ative is that law in case of the king, which is  
 law in no case of the subject. Prerogatives are  
 either direct or incidental. The direct are such  
 positive substantial parts of the royal character  
 and authority, as are rooted in, and spring from,

the king's political person, considered merely by itself, without reference to any other extrinsic circumstances; as, the right of sending ambassadors, of creating peers, and of making war or peace. But such prerogatives as are incidental bear always a relation to something else, distinct from the king's person; and are, indeed, only exceptions, in favor of the crown, to those general rules that are established for the rest of the community: such as, that no costs shall be recovered against the king; and that the king can never be a joint tenant; and that his debt shall be preferred before a debt to any of his subjects.

1. The law ascribes to the king the attribute of sovereignty, or pre-eminence. See SOVEREIGNTY. 2. 'The law also,' says Sir William Blackstone, 'ascribes to the king, in his political capacity, absolute perfection; 'The king can do no wrong.' Which ancient and fundamental maxim is not to be understood as if every thing transacted by the government was of course just and lawful; but means only that whatever is exceptionable in the conduct of public affairs is not to be imputed to the king, nor is he answerable for it personally to his people: for this doctrine would totally destroy that constitutional independence of the crown which is necessary for the balance of power in our free and active, and therefore compounded, constitution. And therefore, if the crown should be induced to grant any franchise or privilege to a subject contrary to reason, or in any wise prejudicial to the commonwealth or a private person, the law will not suppose the king to have meant either an unwise or an injurious action, but declares that the king was deceived in his grant; and thereupon such grant is rendered void, merely upon the foundation of fraud and deception, either by or upon those agents whom the crown has thought proper to employ.' The law determines that in the king can be no negligence or laches; and therefore no delay will bar his right. *Nulum tempus occurrit regi* is the standing maxim upon all occasions: for the law intends that the king is always busied for the public good, and therefore has not leisure to assert his right within the times limited to subjects. In the king also can be no stain or corruption of blood; for if the heir to the crown were attainted of treason or felony, and afterwards the crown should descend to him, this would purge the attainer *ipso facto*. This happened in the case of Henry VII. who, as earl of Richmond, stood attainted, but his assumption of the crown cleared the attainders. Neither can the king, in judgment of law, as king, ever be a minor or under age; and therefore his royal grants and assents to acts of parliament are good, though he has not in his natural capacity attained the legal age of twenty-one. By a statute, indeed, 28 Hen. VIII. c. 17, power was given to future kings to rescind all acts of parliament that should be made while they were under the age of twenty-four: but this was repealed by the stat. 1 Edw. VI. c. 11, so far as related to that prince, and both statutes are declared to be determined by 24 Geo. II. c. 24. It has also been usually thought prudent, when the heir apparent has been very young, to appoint a protector, guardian, or regent, for a

limited time: but the very necessity of such extraordinary provision is sufficient to demonstrate the truth of that maxim of common law, that in the king is no minority; and therefore he has no legal guardian. 3. A third attribute of the king's majesty is his perpetuity. The law ascribes to him, in his political capacity, an absolute immortality. The king never dies; Henry, Edward, or George, may die; but the king survives them all. For, immediately upon the decease of the reigning prince in his natural capacity, his kingship or imperial dignity, by act of law, without any interregnum or interval, is vested at once in his heir; who is, eo-instanti, king to all intents and purposes. The royal prerogative invests the king with a number of authorities and powers; in the exertion whereof consists the executive part of government. This is wisely placed in a single hand by the British constitution, for the sake of unanimity, strength, and despatch. Were it placed in many hands, it would be subject to many wills: which, if disunited and drawing different ways, create weakness in a government; and to unite these and reduce them to one is a work of more time and delay than the exigencies of state will afford. The king of England is therefore not only the chief, but properly the sole magistrate of the nation; all others acting by commission from, and in due subordination to him. In the exertion of lawful prerogative the king is held to be absolute; that is so far absolute that there is no legal authority that can either delay or resist him. He may reject what bills, may make what treaties, may coin what money, may create what peers, may pardon what offences he pleases: unless where the constitution has expressly, or by evident consequence, laid down some exception or boundary; declaring, that thus far the prerogative shall go and no farther. For otherwise the power of the crown would indeed be but a name and a shadow, insufficient for the ends of government, if, where its jurisdiction is clearly established and allowed, any man or body of men were permitted to disobey it, in the ordinary course of law: we do not now speak of those extraordinary recourses to the first principles which are necessary when the contracts of society are in danger of dissolution, and the law proves too weak a defence against the violence of fraud or oppression. And yet the want of attending to this obvious distinction has occasioned these doctrines of absolute power in the prince and of national resistance by the people, to be much misunderstood and perverted by the advocates for slavery on the one hand, and the demagogues of faction on the other. In the exertion, therefore, of these prerogatives which the law has given him, the king is irresistible and absolute, according to the forms of the constitution. And yet, if the consequence of that exertion be manifestly to the grievance or dishonor of the kingdom, the parliament will call his advisers to a just and severe account. For prerogative consisting (as Mr. Locke has well defined it) in the discretionary power of acting for the public good where the positive laws are silent, if that discretionary power be abused to the public detriment, such prerogative is exerted in an unconstitutional

manner. The king's ministers in all such cases are amenable to parliament. Thus the king may make a treaty with a foreign state, which shall irrevocably bind the nation; and yet, when such treaties have been judged pernicious, impeachments have pursued those ministers by whose agency or advice they were concluded.

With regard to all foreign concerns, the king is the delegate or representative of his people. What is done by the royal authority, with regard to foreign powers, is the act of the whole nation: what is done without the king's concurrence is the act only of private men. And, by the statute 2 Hen. V. c. 6, any subject committing acts of hostility upon any nation in league with the king, was declared to be guilty of high-treason: and, though that act was repealed by the stat. 20 Hen. VI. c. 11, so far as relates to the making this offence high-treason, yet it still remains a very great offence against the law of nations, and punishable by our laws, either capitally or otherwise, according to the circumstances of the case.

1. The king, therefore, considered as the representative of his people, has the sole power of sending ambassadors to foreign states, and receiving ambassadors at home. 2. It is also the king's prerogative to make treaties, leagues, and alliances, with foreign states and princes; though in this, as in all other cases, ministers are amenable to parliamentary impeachment for advising the king to conclude any such treaties that are found to be derogatory from the honor and interest of the nation. 3. The king has also the sole prerogative of making war and peace. And therefore, to make a war completely legal and constitutional, it must be publicly proclaimed by the king's authority. In pursuance of which principle, it is with us declared by the statute 4 Hen. V. c. 7, that, if any subjects of the realm are oppressed in the time of truce by any foreigners, the king will grant letters of marque in due form to all that feel themselves aggrieved.

5. Upon exactly the same reason stands the prerogative of granting safe conducts; without which, by the law of nations, no member of one society has a right to intrude into another. Great tenderness is shown by our laws, not only to foreigners in distress (see *WRECK*), but with regard also to the admission of strangers who come spontaneously: for so long as their nation continues at peace with ours, and they themselves behave peaceably, they are under the king's protection, though liable to be sent home whenever the king sees occasion. But no subject of a nation at war with us can, by the law of nations, come into the realm, or can travel himself upon the high seas, or send his goods and merchandise from one place to another, without danger of being seized by our subjects, unless he has letters of safe conduct; which, by divers ancient statutes, must be granted under the king's great seal, and enrolled in chancery, or else they are of no effect; the king being supposed the best judge of such emergencies as may deserve exception from the general law of arms. But passports under the king's sign-manual, or licenses from his ambassadors abroad, are now more usually obtained, and are allowed to be of equal validity. These are the principal prerogatives

of the king respecting this nation's intercourse with foreign nations.

In domestic affairs the king is considered in a great variety of characters; and thence there arises a number of other prerogatives. 1. He is a constituent part of the supreme legislative power; and, as such, has the prerogative of rejecting such provisions in parliament as he judges improper to be passed. 2. The king has the sole power of raising and regulating fleets and armies. The sole prerogative, also, of erecting, manning, and governing of castles and forts, belongs to the king in his capacity of general of the kingdom; and all lands were formerly subject to a tax, for building castles wherever the king thought proper: in consequence of which their number was increased most enormously. The greater part of them being demolished in the wars with the barons, succeeding kings were cautious of suffering them to be rebuilt: and Sir Edward Coke lays it down, that no subject can build a castle, or house of strength embattled, or other fortress defensible, without the license of the king; for the danger which might ensue, if every man at his pleasure might do it.

The king has also the prerogative of appointing ports and havens, for persons and merchandise to pass into and out of the realm, as he in his wisdom sees proper. By the feudal law, all navigable rivers and havens were computed among the regalia, and were subject to the sovereignty of the state. And in England it has always been held that the king is lord of the whole shore, and particularly is the guardian of the ports and havens, which are the inlets and gates of the realm: and therefore, so early as the reign of John, we find ships seized by the king's officers for putting in at a place that was not a legal port. These legal ports were undoubtedly at first assigned by the crown; since to each of them a court of portmote is incident, the jurisdiction of which must flow from the royal authority: the great ports of the sea are also referred to as well-known and established, by stat. 4 Hen. IV. c. 20, which prohibits the landing elsewhere, under pain of confiscation; and the stat. 1 Eliz. c. 11, recites, that the franchise of lading and discharging had been frequently granted by the crown. But, though the king had a power of granting the franchise of havens and ports, yet he had not the power of resumption, or of narrowing and confining their limits when once established; but any person had a right to load or discharge his merchandise in any part of the haven; whereby the revenue of the custom was much impaired and diminished, by fraudulent landings in obscure and private corners. This occasioned the statutes of 1 Eliz. c. 11, and 13 and 14 Car. II. c. 11, sec. 14, which enable the crown, by commission, to ascertain the limits of all ports, and to assign proper wharfs and quays in each port, for the exclusive landing and loading of merchandise. 3. Another capacity in which the king is considered in domestic affairs is as the fountain of justice, and general conservator of the peace of the kingdom. 4. The king is likewise the fountain of honor, office, and privilege; and this in a different sense from that wherein he is styled the fountain of justice, for here he is



really the parent of them. The king is, lastly, considered by the laws of England as the head and supreme governor of the national church. This prerogative was fixed by stat. 26 Hen. VIII. c. 1 and 1 Eliz. c. 1. In virtue of this authority, the king convenes, prorogues, restrains, regulates, and dissolves, all ecclesiastical synods or convocations. From this prerogative, also, of being the head of the church, arises the king's right of nomination to vacant bishoprics, and other ecclesiastical preferments. As head of the church the king is likewise the dernier resort in all ecclesiastical causes; an appeal lying ultimately to him in chancery from the sentence of every ecclesiastical judge: which right was re-  
 'ored to the crown by stat. 25 Hen. VIII. c. 9.

PRES'AGE, *n. s. & v. a.* } Fr. *presage*;  
 PRESAGE'MENT. } Latin *presagium*.  
 Prognostic; presension of futurity; to fore-  
 bode; foretell: presagement is synonymous with  
 presage noun-substantive.

Henry's late *presaging* prophecy  
 Did glad my heart with hope.

*Shakspeare, Henry VI.*

If I may trust the flattering ruth of sleep,  
 My dreams *presage* some joyful news at hand.

*Shakspeare.*

I have spent much inquiry, whether he had any  
 ominous *presagement* before his end.

*Wotton.*

This contagion might have been *presaged* upon  
 consideration of its precursors.

*Harvey on Consumption.*

That cloud, that hangs upon thy brow, *presages*  
 A greater storm than all the Turkish power  
 Can throw upon us.

*Denham's Sophy.*

What power of mind

Foreseeing, or *presaging* from the depth  
 Of knowledge past or present, could have feared  
 How such united force of gods, how such  
 As stood like these, could ever know repulse.

*Milton.*

The falling of salt is an authentick *presagement* of  
 ill luck, from whence notwithstanding nothing can  
 be naturally feared.

*Browne.*

When others fell, this standing did *presage*.  
 The crown should triumph over popular rage.

*Waller.*

Wished freedom I *presage* you soon will find,  
 If heaven be just, and if to virtue kind.

*Dryden.*

That by certain signs we may *presage*  
 Of heats and rains, and wind's impetuous rage,  
 The sovereign of the heavens has set on high  
 The moon to mark the changes of the sky.

*Id.*

Dreams have generally been considered by authors  
 only as revelations of what has already happened, or  
 as *presages* of what is to happen.

*Addison.*

PRESBURG, or POSONYI-*VARMEGYE*, an im-  
 portant palatinate of Hungary, lying in an angle  
 formed by the March and Danube. Its area is  
 1740 square miles. The Carpathians traverse  
 the whole length of this district; but in general  
 the elevations are not great, and they are com-  
 monly covered with vineyards. Of the wine  
 produced, that called the Szent George Ausbruck  
 is inferior only to Tokay. Corn and fruit are  
 produced in the south-east part, particularly in  
 the district called the isle of Schutt. The chief  
 towns are Presburg and Tyrnau; the latter the  
 seat of the court of appeal for the circle to the  
 north of the Danube. Population of the palati-  
 nate 200,000, a mixture of Hungarians, Ger-  
 mans, Bohemians, Croats, and Jews.

PRESBURG, or POSONY, a large town of Hun-  
 gary, on the north bank of the Danube, declared,  
 by a royal decree of 1536, the capital of Hun-  
 gary. The kings are still crowned here, but the  
 viceroy and the higher officers of government  
 reside at Buda; and the diets and supreme  
 courts of justice meet at Pesth. Presburg con-  
 tains at present little that is interesting. Its castle,  
 which lately served as a barrack, was burned down  
 in the early part of the present century; and its  
 walls form only a ruinous square pile, with a  
 tower at each corner. This town stands on a hill  
 of moderate elevation, overlooking a vast plain;  
 and the horizon is open in all directions except  
 in the north-west, where, for nearly a third of its  
 circumference, it is intercepted by the distant  
 mountains. The Danube, here nearly half a  
 mile wide, is crossed by a flying bridge. The  
 fortifications have been demolished; and no dis-  
 tinction is now made between the town and  
 suburbs. The suburbs bear marks of improve-  
 ment: there are here two squares, adorned with  
 statues. The principal church of Presburg is an  
 old Gothic edifice, said to have been built in  
 1090; the other public buildings are the palace  
 of the palatine, the barracks, corn-market, and  
 town-house. Presburg has an academy, a school  
 for the children of nobility, two or three monas-  
 teries, a Catholic and a Lutheran gymnasium.  
 The manufactures, though on a small scale, com-  
 prise woollens, silk, oil, tobacco, and snuff. The  
 trade in corn and linen is considerable. It  
 was here that a treaty was concluded between  
 France and Austria, after the campaign of 1805.  
 Thirty-eight miles east by south of Vienna, and  
 107 W.N.W. of Pesth.

PRESBYTER, *n. s.*

PRESBYTERIAL, *adj.*

PRESBYTERIAN, *adj. & n. s.*

PRESBYTERY, *n. s.*

Lat. *presbyter*;

Gr. *πρεσβυτερος*.

A priest; an elder:

both the adjectives

mean consisting of elders or presbyters;  
 or according to the presbyterian form of church  
 government: presbyterian, as a noun substantive,  
 one who holds with that form: presbytery, a body  
 of elders or priests. See below.

They cannot delegate the episcopal power, properly  
 so called, to *presbyters*, without giving them epis-  
 copal consecration.

*Lesley.*

*Presbyters* absent through infirmity from their  
 churches, might be said to preach by those deputies  
 who in their stead did but read homilies.

*Hooker.*

Those which stood for the *presbytery*, thought their  
 cause had more sympathy with the discipline of  
 Scotland than the hierarchy of England.

*Bacon.*

Chiefly was urged the abolition of episcopal, and  
 the establishing of *presbyterian* government.

*King Charles.*

Flea-bitten synod, an assembly brewed  
 Of clerks and elders ana, like the rude  
 Chaos of *presbytery*, where laymen guide  
 With the tame woolpack clergy by their side.

*Cleveland.*

Who should exclude him from an interest, and so  
 unhappily a more unavoidable away in *presbyterial*  
 determinations?

*Holyday.*

And *presbyters* have their jackpuddings too.

*Hudibras.*

One of the more rigid *presbyterians*.

*Swift.*

PRESBYTER, or elder, is a word borrowed from  
 the Greek translation of the Old Testament,

where it commonly signifies ruler or governor; it being a note of office and dignity, not of age; and in this sense bishops are sometimes called presbyters in the New Testament. The grand dispute between the followers of the Geneva and Roman discipline is about the sameness or difference of presbyters and bishops in the time of the apostles.

**PRESBYTERIANS, PROTESTANT**, so called from their maintaining that the government of the church appointed in the New Testament was by presbyteries, that is, by associations of ministers and ruling elders, possessed all of equal powers, without any superiority among them either in office or in order.

The Presbyterians believe that the authority of their ministers to preach the gospel, to administer the sacraments of baptism and the Lord's supper, and to feed the flock of Christ, is derived from the Holy Ghost by the imposition of the hands of the presbytery. They affirm that there is no order in the church as established by Christ and his apostles superior to that of the presbyters; that all ministers, being ambassadors of Christ, are equal by their commission; that presbyter and bishop, though different words, are of the same import; and that prelacy was gradually established upon the primitive practice of making the moderator or speaker of the presbytery a permanent officer. See **BISHOP**.

In the Scottish church, every regulation of public worship, every act of discipline, and every ecclesiastical censure, which in other churches flows from the authority of a diocesan bishop, or from a convocation of the clergy, is the joint work of a certain number of clergymen and laymen acting together with equal authority, and deciding every question by a plurality of voices. The laymen, who thus form an essential part of the ecclesiastical courts of Scotland, are called ruling elders. Every parish has two or three of these lay-elders, who are grave and serious persons chosen from among the heads of families, of known orthodoxy, and steady adherence to the worship, discipline, and government of the church. Being solemnly engaged to use their utmost endeavours for the suppression of vice, and the cherishing of piety and virtue, and to exercise discipline faithfully and diligently, the minister, in the presence of the congregation, sets them apart to their office by solemn prayer; and concludes the ceremony, which is sometimes called ordination, with exhorting both elders and people to their respective duties. The kirk-session, which is the lowest ecclesiastical judicatory, consists of the minister and those elders of the congregation. The minister is *ex officio* moderator, but has no negative voice over the decision of the session; nor indeed has he a right to vote at all, unless when the voices of the elders are equal and opposite. He may indeed enter his protest against their sentence, if he think it improper, and appeal to the judgment of the presbytery; but this privilege belongs equally to every elder, as well as to every person who may believe himself aggrieved by the proceedings of the session. The deacons, whose proper office it is to take care of the poor, may be present in every session, and offer their counsel on

all questions that come before it; but, except in what relates to the distribution of alms, they have no decisive vote with the minister and elders.

The next judicatory is the presbytery, properly so called, which consists of all the pastors within a certain district, and one ruling elder from each parish, commissioned by his brethren to represent, in conjunction with the minister, the session of that parish. The presbytery treats of such matters as concern the particular churches within its limits; as the examination, admission, ordination, and censuring of ministers; the licensing of probationers, rebuking of gross or contumacious sinners, the directing of the sentence of excommunication, the deciding upon references and appeals from kirk-sessions, resolving cases of conscience, explaining difficulties in doctrine or discipline, and censuring, according to the word of God, any heresy or erroneous doctrine which hath been either publicly or privately maintained within the bounds of its jurisdiction. In presbyteries, the only prerogatives which the pastors have over the ruling elders, are, the power of ordination by imposition of hands, and the privilege of having the moderator chosen from their body. From the judgment of the presbytery there lies an appeal to the provincial synod, which ordinarily meets twice in the year, and exercises over the presbyteries within the province a jurisdiction similar to that which is vested in each presbytery over the several kirk-sessions within its bounds. These synods are composed of the members of the several presbyteries within the respective provinces which give names to the synods. The highest authority in the church of Scotland is the general assembly, which consists of a certain number of ministers and ruling elders, delegated from each presbytery, and of commissioners from the universities and royal boroughs. A presbytery in which there are fewer than twelve parishes sends to the general assembly two ministers and one ruling elder: if it contains between twelve and eighteen ministers, it sends four ministers and two ruling elders; and of twenty-four ministers, when it contains so many, it sends five with two ruling elders. Every royal borough sends one ruling elder, whose election must be attested by the kirk-sessions of their respective boroughs. Every university sends one commissioner from its own body. The commissioners are chosen annually, six weeks before the meeting of the assembly; and the ruling elders are often men of the first eminence in the kingdom for rank and talents. In this assembly, which meets once a year, the king presides by his commissioner, who is always a nobleman; but he has no voice in their deliberations, unless he be a member of assembly, which is sometimes the case. Appeals are brought from all the other ecclesiastical courts in Scotland to the general assembly; and, in questions purely religious, no appeal lies from its determinations. In the subordination of these assemblies, parochial, presbyterial, provincial, and national, the less unto the greater, consists the external order of the church of Scotland.

**PRESCIENT**, *adj.* } Lat. *presciens*. Fore-  
**PRESCIENCE**, *n. s.* } knowing; prophetic:  
**PRESCIOUS**, *adj.* } precious is of the same  
 signification: prescience is foreknowledge; know-  
 ledge of the future.

They tax our policy, and call it cowardice,  
 Forestall our *prescience*, and esteem no act  
 But that of hand.

*Shakspeare. Troilus and Cressida.*

*Prescience*, or foreknowledge, considered in order  
 and nature, if we may speak of God after the man-  
 ner of men, goeth before providence; for God fore-  
 knew all things before he had created them, or before  
 they had being to be cared for; and *prescience* is no  
 other than an infallible foreknowledge. *Raleigh.*

Henry, upon the deliberation concerning the mar-  
 riage of his eldest daughter into Scotland, had  
 showed himself sensible and almost *prescient* of this  
 event. *Bacon.*

God's *prescience*, from all eternity, being but the  
 seeing every thing that ever exists as it is, contin-  
 gents as contingents, necessary as necessary, can  
 neither work any change in the object, by thus seeing  
 it, nor itself be deceived in what it sees. *Hammond.*

If certain *prescience* of uncertain events imply a  
 contradiction, it seems it may be struck out of the  
 omniscieny of God, and leave no blemish behind.  
*More.*

Freedom was first bestowed on human race,  
 And *prescience* only held the second place.

*Dryden.*

Thrice happy thou, dear partner of my bed,  
 Whose holy soul the stroke of fortune fled;  
*Prescious* of ills, and leaving me behind,  
 To drink the dregs of life. *Id. Æneis.*

Of things of the most accidental and mutable na-  
 ture God's *prescience* is certain. *South.*

Who taught the nations of the field and wood,  
*Prescient*, the tides or tempests to withstand?

*Pope.*

**PRESCIENCE**, in theology, prevision, or fore-  
 knowledge; that knowledge which God has of  
 things to come. The doctrine of predestination  
 is founded on the *prescience* of God, and on the  
 supposition of all futurity being present to him.  
 The apostle Peter, in his celebrated sermon at  
 Jerusalem, asserts both doctrines, of *prescience*  
 and accountability, in one sentence, Acts ii. 23.  
 'Him, being delivered by the determinate coun-  
 sel and foreknowledge of God, ye have taken,  
 and by wicked hands have crucified and slain.'

**PRESCIND**, *v. a.* } Lat. *prescindo*. To  
**PRESCIND'ENT**, *adj.* } cut off; to abstract: ab-  
 stracting.

A bare act of obliquity does not only *prescind*  
 from, but positively deny such a special dependence.  
*Norris.*

We may, for one single act, abstract from a re-  
 ward, which nobody who knows the *prescindent* facul-  
 ties of the soul can deny. *Cheyne.*

**PRESCOT**, a market town of Lancashire,  
 with a market on Tuesday for corn, provisions,  
 and cattle. It has considerable manufactures of  
 sail-cloth, watches, &c. The church is a hand-  
 some building, having a steeple fifty-two yards  
 high, allowed to be the most complete in the  
 county. There is also a dissenters meeting-  
 house, a free-school, and several alms-houses.  
 At St. Helen's, near this town, is an extensive  
 plate glass manufactory, in which 300 persons  
 are employed; and near it is another for smelt-  
 ing and refining copper ore. Near this town lies

Prescot, the seat of the earl of Derby. **Pres-**  
 cot lies eight miles east of Liverpool, and 198  
 N. N. W. of London.

**PRESCRIBE**, *v. a. & v. n.* } Lat. *prescribo*  
**PRESCRIP'T**, *adj. & n. s.* } To set down au-  
**PRESCRIPTION**, *n. s.* } thoritatively; or-  
 der; direct; influence: *prescript* is directed: laid  
 down formally: *prescript*, noun substantive, and  
*prescription*, direction; model; medical recipe.  
 long used custom.

Doth the strength of some negative arguments  
 prove this kind of negative argument strong, by force  
 whereof all things are denied which scripture affirm-  
 eth not, or all things which scripture *prescribeth* not  
 condemned? *Hooper.*

Those very laws so added, they themselves do not  
 judge unlawful; as they plainly confess both in mat-  
 ter of *prescript* attire, and of rites appertaining to  
 burial. *Id.*

You tell a pedigree

Of threescore and two years, a silly time  
 To make *prescription* for a kingdom's worth.

*Shakspeare.*

My father left me some *prescriptions*  
 Of rare and proved effects; such as his reading  
 And manifest experience had collected  
 For general sovereignty. *Id.*

Use such as have prevailed before in things you  
 have employed them; for that breeds confidence, and  
 they will strive to maintain their *prescription*.

*Bacon's Essays.*

To the blanc moon her office they *prescribed*.  
*Milton.*

By his *prescript*, a sanctuary is framed  
 Of cedar, overlaid with gold. *Id.*

A reserve of puerility we have not shaken off from  
 school, where, being seasoned with minor sentences,  
 they *prescribe* upon our riper years, and never are  
 worn out but with our memories. *Broune.*

Nor did he ever with so much regret submit unto  
 any *approving*. *Fell.*

Approving of my obstinacy against all common  
*prescriptions*, he asked me whether I had never heard  
 of the Indian way of curing the gout by moxa.

*Temple.*

There's joy, when to wild will you laws *prescribe*,  
 When you bid fortune carry back her bribe.

*Dryden.*

The extremest ways they first ordain,  
*Prescribing* such intolerable pain,  
 As none but Cæsar could sustain. *Id.*

Our poet bade us hope this grace to find,  
 To whom by long *prescription* you are kind. *Id.*

The assuming an authority of dictating to others,  
 and a forwardness to *prescribe* to their opinions, is a  
 constant concomitant of this bias of our judgments.

*Locke.*

It will be found a work of no small difficulty to  
 dispossess a vice from that heart where long posses-  
 sion begins to plead *prescription*. *South.*

The Lucquese plead *prescription* for hunting in one  
 of the duke's forests that lies upon their frontiers.

*Addison.*

That obligation upon the lands did not *prescribe*  
 or come into disuse, but by fifty consecutive years of  
 exemption. *Arbutnot.*

Modern 'pothecaries taught the art  
 By doctors' bills to play the doctor's part,  
 Bold in the practice of mistaken rules,  
*Prescribe*, apply, and call their masters fools.

*Pope.*

Should any man argue that a physician under-  
 stands his own art best; and therefore, although he

should *prescribe* poison to all his patients, he cannot be justly punished, but is answerable only to God!

*Swift.*

So long a *prescription* supposes an acquiescence in the other claimants: and that acquiescence supposes also some reason, perhaps now unknown, for which the claim was forborne.

*Johnson.*

Yet half mankind maintain a churlish strife  
With Him, the Donor of eternal life,  
Because the dead, by which his love confirms  
The largess he bestows, *prescribes* the terms. *Cowper.*

**PRESCRIPTION**, in English law, is a title acquired by use and time, and allowed by law; as when a man claims any thing, because he, his ancestors, or they whose estate he hath, have had or used it all the time whereof no memory is to the contrary: or it is where for continuance of time, *ultra memoriam hominis*, a particular person hath a particular right against another. There is a difference between prescription, custom, and usage. Prescription hath respect to a certain person, who by intendment may have continuance for ever; but custom is local, and always applied to a certain place; as time out of mind there has been such a custom in such a place, &c. And prescription belongeth to one or a few only; but custom is common to all. Usage differs from both, for it may be either to persons or places: as to inhabitants of a town to have a way, &c. A custom and prescription are in the right; usage is in the possession; and a prescription, that is good for the matter and substance, may be bad by the manner of setting it forth: but where that which is claimed as a custom, in or for many, will be good, that regularly will be so when claimed by prescription for one. Prescription is to be time out of mind; though it is not the length of time that begets the right of prescription, nothing being done by time, although every thing is done in time; but it is a presumption in law that a thing cannot continue so long quiet, if it was against right or injurious to another.

**PRESEANCE**, *n. s.* Fr. *preseance*. Priority of place in sitting. Not used.

The guests, though rude in their other fashions,  
May, for their discreet judgment in precedence and *preseance*, read a lesson to our civilest gentry.

*Carew's Survey of Cornwall.*

**PRESEN'SION**, *n. s.* Lat. *presensio*. Perception beforehand.

The bedghoz's *presension* of winds is exact. *Browne.*

PRESENT, <i>adj.</i> , <i>v. a.</i> , & <i>n. s.</i>	Fr. <i>present</i> ;
PRESEN'CE, <i>n. s.</i>	Latin <i>presens</i> .
PRESEN'CE-CHAMBER,	In company;
PRESEN'CE-ROOM,	face to face;
PRESEN'TANEOUS, <i>adj.</i>	at hand; ready;
PRESENTABLE,	quick in
PRESENTATION, <i>n. s.</i>	emergencies;
PRESENTATIVE, <i>adj.</i>	attention; now
PRESENTEE, <i>n. s.</i>	existent or now
PRESENTER,	specified; not
PRESENTIAL, <i>adj.</i>	past or future;
PRESENTIALITY, <i>n. s.</i>	'at present' is
PRESENTIATE, <i>v. a.</i>	used for now,
PRESENTI'IC, <i>adj.</i>	or, at the pre-
PRESENTI'ICALLY, <i>adv.</i>	sented time: to
PRESENTLY, <i>adv.</i>	present, is to
PRESENTMENT, <i>n. s.</i>	place, particu-
PRESENTNESS.	

larly of a superior; introduce; exhibit; offer, give, or put into the hands ceremoniously; distinguish with gifts; lay formally before a court, or high authority: a present, something offered; something given; something given ceremoniously; a letter or mandate, *per presentes*: presence is, state of being present or together; approach face to face, or into view, particularly of a superior; a number assembled before a superior; room in which a superior shows himself; the superior so shown; port; air; mien; readiness; aptitude: the two compounds that follow are obvious in their meaning: presentaneous is, quick; immediate: presentable, what may be presented: presentation, the act of presenting; exhibition; particularly the act of giving any one an ecclesiastical benefice: presentative, presentable in an ecclesiastical sense: presentee, one presented to a benefice: presenter, one who presents: presential, supposing actual or real presence: the noun-substantive corresponding: presentiate, to make present: presentific (obsolete), making present: presently, soon after; and (obsolete) at this time; now: presentment, the act of presenting or thing presented; representation in law: presentment is a denunciation of the jurors, or some other officer, as justice, constable, searcher, surveyor, of an offence enquirable in the court to which it is presented.—*Cowell*. Presentness is quickness at emergencies; readiness of mind, arising from fortitude.

The shepherd Dorus answered with such a trembling voice and abashed countenance, and oftentimes so far from the matter, that it was some sport to the young ladies, thinking it want of education, which made him so discountenanced with unwonted *preseance*.

*Sidney.*

The towns and forts you *presently* have are still left unto you to be kept either with or without garri-  
sons, so as you alter not the laws of the country.

*Id.*

By them they pass, all gazing on them round,  
And to the *presence* mount, whose glorious view  
Their frail amazed senses did confound. *Spense*

Tell on, quoth she, the woeful tragedy,  
The which these reliques sad *present* unto. *Id.*

Prayers are sometimes a *presentation* of mere desires, as a mean of procuring desired effects at the hand of God. *Hooker.*

To speak of it as requireth, would require very long discourse; all I will *presently* say is this. *Id.*

He sent part of the rich spoil with the admiral's ensign, as a *present* unto Solymán. *Knolles.*

To-night we hold a solemn supper,  
And I'll request your *presence*. *Shakespeare.*  
I know not by what power I am made bold,  
In such a *presence* here, to plead my thoughts. *Id.*

An't please your grace, the two great cardinals  
Wait in the *presence*. *Id. Henry VIII.*

Plain Clarence!  
I will send thy soul to heaven,  
If heav'n will take the *present* at our hands. *Shakespeare.*

Be it known to all men by these *resents*. *Id.*  
He knows not what he says; and vain is it,  
That we *present* us to him. *Id. King Lear.*

When comes your book forth?  
—Upon the heels of my *presentation*. *Shakespeare.*

Covetous ambition, thinking all too little which *presently* it hath, suppeth itself to stand in need of all which it hath not. *Ralsigh.*

Virtue is best in a body that is comely, and that hath rather dignity of *presence* than beauty of aspect. *Bacon.*

If a man write little, he had need have a great memory; if he conier little, he had need have a *present* wit; and if he read little, he had need have much cunning. *Id.*

He was appointed admiral, and *presented* battle to the French navy, which they refused. *Hayward.*

Be *present* to her now, as then

And let not proud and factious men

Against your wills oppose their mights. *Ben Jonson.*

The Lady Anne of Bretagne, passing through the *presence* in the court of France, and espying Chartier, a famous poet, leaning upon his elbow fast asleep, openly kissing him, said, We must honour with our kiss the mouth from whence so many sweet verses have proceeded. *Peacham.*

Mrs. Gulston, possessed of the impropriate parsonage of Bardwell, did procure from the king leave to annex the same to the vicarage, and to make it *presentative*, and give them both to St. John's College in Oxon. *Spelman.*

Men that very *presence* fear,

Which once they knew authority did bear. *Daniel.*

Some plagues partake of such malignity, that, like a *presentaneous* poison, they enecate in two hours. *Harvey.*

Be not often *present* at feasts, not at all in dissolute company; pleasing objects steal away the heart. *Taylor.*

Now every leaf, and every moving breath

*Presents* a foe, and every foe a death. *Denham.*

A *present* good may reasonably be parted with, upon a probable expectation of a future good, which is more excellent. *Wilkins.*

Goring had a much better understanding, a much *seener* courage, and *presentness* of mind in danger. *Clarendon.*

Thou with eternal Wisdom didst converse,

Wisdom thy sister, and with her did'st play

In *presence* of the Almighty Father, pleas'd

With thy celestial song. *Milton.*

To her the sov'reign *presence* thus replied. *Id.*

Thou future things canst represent

As *present*. *Id.*

When he saw descend

The Son of God to judge them, terrified

He fled; not hoping to escape, but shun

The *present*; fearing, guilty, what his wrath

Might suddenly inflict. *Id.*

Say, heav'nly muse, shall not thy sacred vein

Afford a *present* to the infant God? *Id.*

On to the sacred hill

They led him high applauded, and *present*

Before the seat supreme. *Id. Paradise Lost.*

Thou therefore now advise,

Or hear what to my mind first thoughts *present*. *Milton.*

Thus I hurl

My dazzling spells into the spongy air,

Of power to cheat the eye with blear illusion,

And give it false *presentments*, lest the place

And my quaint habits breed astonishment. *Id.*

But neither of these are any impediment, because the regent thereof is of an infinite immensity more than commensurate to the extent of the world, and such as is most intimately *present* with all the beings of the world. *Hate.*

He made effectual provision for recovery of *and* *vowsons* and *presentations* to churches. *Id.*

Perhaps I have not so well consulted the reputations of my intellectuals, in bringing their imperfections into such discerning *presences*. *Glanville's Scepiss.*

Errors, not to be recalled, do find

Their best redress from *presence* of the mind;

Courage our greatest failings does supply. *Waller.*

They that are to love inclined,

Swayed by chance, not choice or art,

To the first that's fair or kind,

Make a *present* of their heart. *Id.*

The whole evolution of times and ages, from *ever-*lasting to everlasting, is collectedly and *presentifichly* represented to God at once, as if all things and actions were, at this very instant, really *present* an existent before him. *More.*

Since clinging cares and trains of inbred fears,

Not awed by arms, but in the *presence* bold,

Without respect to purple or to gold. *Dryden.*

Nor could I hope in any place but there,

To find a god so *present* to my prayer. *Id.*

Somewhat is sure designed by fraud or force;

Trust not their *presence*, nor admit the horse. *Id.*

He now *presents*, as ancient ladies do,

That courted long, at length are forced to woo. *Id.*

Octavia *presented* the poet, for his admirable elegy on her son Marcellus. *Id.*

Should I *present* thee with rare figured plate,

O how thy rising heart would throb and beat. *Id.*

These *presentations* of fighting on the stage are necessary to produce the effects of an heroic play. *Id.*

A good bodily strength is a felicity of nature, but nothing comparable to a large understanding and ready *presence* of mind. *L'Estrange.*

'Tis a high point of philosophy and virtue for a man to be so *present* to himself as to be always provided against all accidents. *Id.*

Men that set their hearts only upon the *present*, without looking forward into the end of things, are struck at. *Id.*

The thing was acceptable, but not the *presenter*. *Id.*

If these nerves, which are the conduits to convey them from without to their audience in the brain, the mind's *presence-room*, are so disordered as not to perform their functions, they have no postern to be admitted by. *Locke.*

How great his *presence*, how erect his look,

How ev'ry grace, how all his virtuous mother

Shines in his face, and charms me from his eyes! *Smith.*

The fancy may be so strong as to *presentiate*, upon one theatre, all that ever it took notice of in times past. *Grew.*

By union, I do not understand that which is local or *presential*, because I consider God as omnipresent. *Norris.*

Thou spendest thy time in waiting upon such a great one, and thy estate in *presenting* him; and, after all, hast no other reward, but sometimes to be smiled upon, and always to be smiled at. *South.*

This eternal, indivisible act of his existence makes all futures actually *present* to him; and it is the *presentiality* of the object which founds the unerring certainty of his knowledge. *Id. Sermons.*

Tell him that no history can match his policies, and *presently* the sot shall measure himself by himself. *South.*

Who, since their own short understandings reach

No further than the *present*, think e'en the wise

Speak what they think, and tell tales of themselves. *Houze*

*Knelier*, with silence and surprise,  
We see Britannia's monarch rise,  
And aw'd by thy delusive hand,  
As in the *presence-chamber* stand. *Addison*.

The state is at *present* very sensible of the decay  
in their trade. *Id.*

Our laws make the ordinary a disturber, if he  
does not give institution upon the fitness of a person  
presented to him, or at least to give notice to the  
patron of the disability of his *presentee*. *Ayliffe*.

Incumbents of churches *presentable* cannot, by  
their sole act, grant their incumbencies to others;  
but may make leases of the profits thereof. *Id.*

The moments past, if thou art wise, retrieve  
With pleasant mem'ry of the bliss they gave;  
The *present* hours in *present* mirth employ,  
And bribe the future with the hopes of joy. *Prior*.

Folks in mudwall tenement,  
Affording peppercorn for rent,  
*Present* a turkey or a hen,  
To those might better spare their ten. *Id.*

A graceful *presence* bespeaks acceptance, gives a  
force to language, and helps to convince by look and  
posture. *Collier*.

The *present* age hath not been less inquisitive  
than the former ages were.

*Woodward's Natural History*.

What, shall the curate controul me? have not I  
the *presentation*? *Gay*.

That he put these bishops in the places of the de-  
creased by his own authority is notoriously false;  
for the duke of Saxony always *presented*. *Atterbury*.

So ladies in romance assist their knight,  
*Present* the spear, and arm him for the fight. *Pope*.

The grand juries were practised with, to *present*  
the said pamphlet with all aggravating epithets, and  
their *presentments* published for several weeks in all  
the newspapers. *Swift*.

The ample mind keeps the several objects all  
within sight, and *present* to the soul. *Watts*.

Lectonides's memory is ever ready to offer to his  
mind something out of other men's writings or con-  
versations, and is *presenting* him with the thoughts of  
other persons perpetually. *Id.*

We have always the same natures, and are every  
where the servants of the same God, as every place  
is equally full of his *presence*, and every thing is  
equally his gift. *Law*.

This much I believe may be said, that the much  
greater part of them are not brought up so well, or  
accustomed to so much religion, as in the *present* in-  
stance. *Id.*

The *present* moment like a wife we shun,  
And ne'er enjoy, because it is our own. *Young*.

The ideas of pain, and above all of death, are so  
very affecting, that whilst we remain in the *presence*  
of whatever is supposed to have the power of inflict-  
ing either, it is impossible to be perfectly free from  
it. *Burke*.

**PRESENTATION**, in ecclesiastic law. See **AD-  
VOCATION**, and **PATRONAGE**.

**PRESENTATION OF OUR LADY**, the title of two  
orders of nuns. The first was established in  
France, about 1627, by Nicholas Sanguin, bishop  
of Senlis; it was approved by Urban VIII.  
This order never made any great progress. The  
second was established in 1664, when Frederick  
Borromeo, being apostolical visitor, in the Val-  
taise, was intreated by some devout maids at  
Mortemoro to allow them to live in community in  
a retired place; which he granted, and erected

them into a congregation, under the title of con-  
gregation of our Lady. They lived under the rule  
of St. Augustine.

**PRESENTATION OF THE VIRGIN**, a feast of the  
Romish church, celebrated on the 21st of No-  
vember, in memory of the Holy Virgin's being  
presented by her parents in the temple, to be  
there educated. Emanuel Comnenus, who  
began to reign in 1143, makes mention of this  
feast in his constitution. Some imagine it to  
have been established among the Greeks in the  
eleventh century; and think they see evident  
proofs of it in some homilies of George of Ni-  
comedea, who lived in the time of Photius. Its  
institution in the west is ascribed to Gregory XI.  
in 1372. Some think it was instituted in me-  
mory of the ceremony practised among the  
Jews for their new-born females; corresponding  
to the circumcision on the eighth day for males.

**PRESENTMENT**, in law. A presentment, pro-  
perly speaking, is the notice taken by a grand  
jury of any offence from their own knowledge or  
observation, without any bill of indictment laid  
before them at the suit of the king; as the pre-  
sentment of a nuisance, a libel, and the like;  
upon which the officer of the court must after-  
wards frame an indictment, before the party  
presented can be put to answer it. An inquisi-  
tion of office is the act of a jury, summoned by  
the proper officer to enquire of matters relating  
to the crown, upon evidence laid before them.  
Some of these are in themselves convictions,  
and cannot afterwards be traversed or denied;  
and therefore the inquest, or jury, ought to hear  
all that can be alleged on both sides. Of this  
nature are all inquisitions of *felo de se*; of flight  
in persons accused of felony; of deadands, and  
the like; and presentments of petty offences in the  
sheriff's tourn or court-leet, whereupon the presid-  
ing officer may set a fine. Other inquisitions may  
be afterwards traversed and examined; as par-  
ticularly the coroner's inquisition of the death of  
a man, when it finds any one guilty of homicide;  
for in such cases the offender so presented must  
be arraigned upon this inquisition, and may dis-  
pute the truth of it; which brings it to a kind of  
indictment, the most usual and effectual means  
of prosecution.

**PRESERVE'**, *v. a. & n. s.* } Fr. *preserver*;  
**PRESERVATION**, *n. s.* } low Lat. *preser-*

**PRESERVATIVE**, *adj. & n. s.* } *vo.* To keep;  
**PRESERVER**. } save; defend;

protect from decay: as a noun substantive, some-  
thing so protected, as 'preserved fruit': preser-  
vation is, the art or care of preserving: preser-  
vative, preventive; having the power of preserv-  
ing; that which has this power: preserver, a defen-  
der or protector; one who keeps from ruin or  
mischief; he who makes artificial preserves.

God sent me to *preserve* you a posterity, and save  
your lives. *Genesis* xlv. 7.

The Lord shall deliver me from every evil work,  
and *preserve* me unto his heavenly kingdom.

2 Timothy.

Of all wild beasts *preserve* me from a tyrant;  
And of all tame, a flatterer. *Sir P. Sidney*.

If we think that the church needeth not those an-  
cient *preservatives*, which ages before us were glad to  
use, we deceive ourselves. *Hooker*.

Nature does require  
Her times of preservation, which, perforce,  
I give my tendance to.

*Shakspeare. Henry VIII.*

Sit, my preserver, by thy patient's side.

*Shakspeare.*

It hath been anciently in use to wear tablets of arsenick, as preservatives against the plague; for that, being poisons themselves, they draw the venom from the spirits.

*Bacon.*

Every senseless thing, by nature's light,  
Doth preservation seek, destruction shun.

*Davies.*

Bodies kept clean, which use preservatives, are likely to escape infection.

*Harvey.*

He did too frequently gratify their unjustifiable designs, a guilt all men, who are obnoxious, are liable to, and can hardly preserve themselves from.

*Clarendon.*

We can preserve unhurt our minds.

Were there truth herein, it were the best preservative for princes, and persons exalted unto such fears.

*Broune.*

All this is easily discerned in those fruits which are brought in preserves unto us.

*Id.*

Our allwise Maker has put into man the uneasiness of hunger, thirst, and other natural desires, to determine their wills for the preservation of themselves, and the continuation of their species.

*Loche.*

To be indifferent which of two opinions is true is the right temper of the mind, that preserves it from being imposed on, till it has done its best to find the truth.

*Id.*

To be always thinking, perhaps, is the privilege of the infinite Author and preserver of things, who never slumbers nor sleeps; but is not competent to any finite being.

*Id.*

The fruit with the husk, when tender and young, makes a good preserve.

*Mortimer.*

Andrew Doria has a statue erected to him, with the glorious title of deliverer of the commonwealth; and one of his family another, that calls him its preserver.

*Addison.*

The most effectual preservative of our virtue is to avoid the conversation of wicked men.

*Rogers.*

Every petty prince in Germany must be intreated to preserve the queen of Great Britain upon her throne.

*Swift.*

Molly is an Egyptian plant, and was really made use of as a preservative against enchantment.

*Broome.*

**PRESERVER.** M'INTOSH'S PATENT WATER-PROOF LIFE PRESERVER. This is a simple but ingenious adaptation of air-bags, made of waterproof cloth or canvas, to the support of the body in water. It consists of two strips of waterproof cloth, each about four inches broad and a yard long, or just what will easily surround the body, fastened together at the edges in the form of a narrow bag without any opening, save a small aperture at the side, into which a cock is inserted for the admission of air. To render it perfectly air tight, the cloth is waterproofed while the bag is making, and it is completely fastened by folding the stripes over each other at their junction. The air is simply introduced by blowing with the mouth through the cock, which is to be turned as soon as a sufficient quantity has been admitted, and it may then be applied round the body for use. The proper place to fasten it is immediately under the arms and across the breast, for which purpose it is

furnished with a piece of strong tape, the two ends of which are sewed to the edge of the bag where it is joined, about two or three inches on each side of the middle, where the cock is firmly fastened and made perfectly air-tight; this piece of tape is just sufficiently wide to admit the head easily between it and the bag, and, when put on, it causes the latter to hang down from the neck a little below the breast, and to pass immediately under the arms round to the back, where it is fastened by two other pieces of tape sewed to the two ends of the bag; these pieces may be made long enough to allow them to be brought round and fastened in front to prevent accidents in the event of their loosening behind. A small piece of tape about two inches long is likewise fastened across the bag at the middle, to allow the other tying pieces to pass through and to prevent them from slipping below the bag, and occasioning the slightest apprehension of danger, in the management of the apparatus. The air may be introduced into the bag either before or after it is placed round the body and fastened; if it hold more air than what is necessary to support the individual using it in water, he will be the best judge of the proper quantity by inflating it before he puts it on; but if it just hold the exact quantity, or very little more, it is quite immaterial whether it be inflated before or not; though we are of opinion it is always better to follow the former plan. There is not the smallest fear of bursting the bag in any case, because, as soon as it is full, any individual will find that he can blow no longer, and will be obliged to desist.

With an apparatus of this kind, which may be had at a very trifling expense, a man may throw himself into the sea with perfect safety, and he may float 100 or 1000 miles with his head and shoulders above water, without the least inconvenience, save what he would suffer from hunger or cold. He will not find it necessary to make the smallest exertion to keep himself in a proper position; for owing to the manner in which the apparatus is placed, and to the equal distribution of the air all round his body, he will preserve nearly an erect posture as long as he pleases; by making the smallest exertion, however, he may take any other position he may find most agreeable: he may lie at his ease on his back, or on one side, or lean forward just as he has a mind; do what he may he cannot sink, unless he chooses to open the cock, and then he must go to the bottom unless he can swim.

**PRESIDE**, *v. n.* } *Fr. presider; Lat. præ-*  
**PRESIDENCY**, *n. s.* } *sideo.* To have authority  
**PRESIDENT**, }  
**PRESIDENTSHIP**. } *over; be set over; presi-*  
dency is superintending:  
president is, one placed in chief authority; a governor; prefect; tutelary power: presidentship, an office or station.

When things came to trial of practice, their pastors' learning would be at all times of force to overpersuade simple men, who, knowing the time of their own presidentship to be but short, would always stand in fear of their ministers' perpetual authority.

*Hooker.*

How might those captive Israelites, under the oversight and government of Assyrian presidents, be able to leave the places they were to inhabit?

*Brewerwood on Languages.*

As the *president* of my kingdom, will I  
Appear there for a man.

*Shakespeare. Antony and Cleopatra.*

This last complaint the indulgent ears did pierce  
Of just Apollo, *president* of verse.

*Waller.*

Some o'er the publick magazines *preside*,  
And some are sent new forage to provide.

*Dryden.*

What account can be given of the growth of plants  
from mechanical principles, moved without the *pre-*  
*sudency* and guidance of some superior agent?

*Ray on the Creation.*

The tutor sits in the chair as *president* or mode-  
rator, to see that the rules of disputation be ob-  
served.

*Watts.*

O'er the plans  
Of thriving *peace*, thy thoughtful sires *preside*.

*Thomson.*

**PRESS, v. a., v. n. & n. s.** } Fr. *presser*; Lat. *presso*. To squeeze;  
**PRESSER,** [n. s.] } compress; constrain;  
**PRESS'GANG,** } crush; drive with vio-  
**PRESS'INGLY, adv.** } lence; compel; urge;  
**PRESS'ION, n. s.** } make earnest; force  
**PRESS'ITANT, adj.** } into naval or military  
**PRESSMAN, n. s.** } service: as a verb neuter,  
**PRESS'MONEY,** } to act with or un-  
**PRESS'URE,** } der compulsive vio-  
**PREST, adj. & n. s.** } lence; go forward with violence or energy;  
crowd; come or go importunately or vehemently;  
urge with vehemence; influence strongly; invade: a press is, an instrument used for squeezing, crushing, or compressing; particularly the machine for printing books; a crowd; tumult; violent tendency; commission for impressing men in a military sense: a presser and pressman, one who works a press; also one who forces away another: pressgang, a crew of men aiding a military press-officer: pression and pressure mean, the act of pressing, or force with which any thing is pressed; impression; stamp; oppression; distress: pressitant, gravitating; heavy: pressmoney, money given to bind to military service: prest is, ready; not dilatory; 'this is said to have been the original sense of the word prest men; men, not forced into the service, as now we understand it, but men, for a certain sum received, prest, or ready to march at command.' Johnson: also, neat; tight: as a noun substantive, a loan.

The grapes I *pressed* into Pharaoh's cup. *Genesis.*  
He *pressed* upon them greatly; and they turned in.

*Id.*

The posts that rode upon mules and camels, went  
out, being hastened and *pressed* on by the king's  
commands.

*Ether.*

The *press* is full, the fats overflow. *Joel* iii. 13.  
For he had healed many, insomuch that they  
*pressed* upon him for to touch him. *Mark* iii. 10.  
Good measure *pressed* down, shaken together, and  
running over, shall men give into your bosom.

*Luke* vi. 38.

I *press* toward the mark for the prize.

*Philippians.*

More wealth any where, to be briefe,  
More people, more handsome and *prest*  
Where nnd ye?

*Tusser's Husbandry.*

She held a great gold chain ylinked well,  
Whose upper end to highest heaven was knit,  
And lower part did reach to lowest hell,  
And all that *prest* did round about her swell,  
To catchen hold of that long chain.

*Spenser.*

The experience of his goodness in her own deli-  
verance, might cause her merciful disposition to take  
so much the more delight in saving others, whom the  
like necessity should *press*.

*Hooker.*

Gritus desired nothing more than to have con-  
firmed the opinion of his authority in the minds of  
the vulgar people, by the *prest* and ready attendance  
of the Vayoud.

*Knolles's History of the Turks.*

The Turks gave a great shout, and *pressed* in on  
all sides, to have entered the breach.

*Knolles.*

Once or twice she heaved the name of father  
Pantingly forth, as if it *prest* her heart.

*Shakspeare.*

Come with words as medical as true,  
Honest as either, to purge him of that humour  
That *presses* him from sleep.

*Id.*

For every man that Bolingbroke hath *pressed*  
To lift sharp steel against our golden crown,  
Heaven for his Richard hath in store  
A glorious angel.

*Id. Richard II.*

From London by the king I was *prest* forth.

*Shakspeare.*

I make bold to *press*  
With so little preparation.

*Id.*

These letters are of the second edition; he will  
print them out of doubt, for he cares not what he  
puts into the *press*, when he would put us two in.

*Id.*

Who is it in the *press* that calls on me?

*Id. Julius Cæsar.*

Creep into the kiln hole.—Neither *press*, coffer,  
chest, trunk; but he hath an abstract for the remem-  
brance of such places.

*Shakspeare.*

If I be not ashamed of my soldiers, I am a  
sowed gurnet; I have misused the king's *press*.

*Id.*

From my memory  
I'll wipe away all trivial fond records,  
All saws of books, all forms, all *pressures* past,  
That youth and observation copied there.

*Id.*

Concerning the musters and *presses* for sufficient  
mariners to serve in his majesty's ships, either the  
care is very little, or the bribery very great.

*Raleigh.*

Let them be *pressed*, and ready to give succours  
to their confederates, as it ever was with the  
Romans; for, if the confederate had leagues defen-  
sive, the Romans would ever be the foremost.

*Bacon.*

The less blood he drew, the more he took of trea-  
sure; and, as some construed it, he was the more  
sparing in the one, that he might be the more *press-*  
*ing* in the other.

*Id.*

A wise father ingeniously confessed, that those,  
which persuaded *pressure* of consciences, were com-  
monly interested therein.

*Id.*

He required of the city a *prest* of six thousand  
marks; but he could obtain but two thousand  
pounds.

*Id.*

Each mind is *prest*, and open every ear,  
To hear new tidings, though they no way join us.

*Fairfar.*

Mine own and my people's *pressures* are grievous,  
and peace would be very pleasing.

*King Charles.*

Only one path to all; by which the *pressmen* came.

*Chapman.*

The one contracts his words, speaking *pressingly*  
and short; the other delights in long-breathed ac-  
cents.

*Hovel.*

The endeavour to raise new men for the recruit of  
the army by *pressing*, found opposition in many places.

*Clarendon.*

He *pressed* her matron lips  
With kisses pure.

*Milton.*

His obligation to read not only classick authors,  
but the more recent abortions of the *press*, wherein he  
proved frequently concerned.

*Felt.*



His modesty might be secured from *pressure* by the concealing of him to be author. *Id.*

The genuine price of lands in England would be twenty years' purchase, were it not for accidental *pressure* under which it labours. *Child on Trade.*

Neither the celestial matter of the vortices, nor the air, nor water, are *pressitant* in their proper places. *More.*

Chymists I might *press* with arguments, drawn from some of the eminentest writers of their sect. *Bayle.*

If there be fair proofs on the one side, and none at all on the other, and if the most *pressing* difficulties be on that side on which there are no proofs, this is sufficient to render one opinion very credible, and the other incredible. *Tillotson.*

I was *prest* by his majesty's commands, to assist at the treaty. *Temple's Miscellanies.*

Their morning milk the peasants *press* at night, Their evening milk before the rising light. *Dryden.*

He gapes; and straight With hunger *prest*, devours the pleasing bait. *Id.*

He *pressed* a letter upon me, within this hour, to deliver to you. *Id. Spanish Fryar.*

She took her son, and *press'd* The illustrious infant to her fragrant breast. *Dryden.*

The peaceful peasant to the wars is *prest*, The fields lie fallow in inglorious rest. *Id.*

The insulting victor *presses* on the more And treads the steps the vanquished trod before. *Id.*

Thronging crowds *press* on you as you pass, And with their eager joy may triumph slow. *Id.*

A new express all Agra does affright, Darah and Aurengzebe are joined in fight; The *press* of people thickens to the court, The impatient crowd devouring the report. *Id.*

A great many uneasinesses always soliciting the will, it is natural that the greatest and most *pressing* should determine it to the next action. *Locke.*

After *pressing* out of the colesseed for oil, in Lincolnshire, they burn the cakes to heat their ovens. *Mortimer.*

His easy heart received the guilty flame, And from that time he *prest* her with his passion. *Smith.*

Why has there been now and then a kind of a *press* issued out for ministers, so that as it were the vagabonds and loiterers were taken in? *Davenant.*

Be sure to *press* upon him every motire. *Addison.*

She is always drawn in a posture of walking, it being as natural for Hope to *press* forward to her proper objects as for Fear to fly from them. *Id.*

If light consisted only in *pression*, propagated without actual motion, it would not be able to agitate and heat the bodies which refract and reflect it; if it consisted in motion propagated to all distances in an instant, it would require an infinite force every moment, in every shining particle, to generate that motion: and if it consisted in *pression* or motion, propagated either in an instant or in time, it would bend into the shadow. *Newton's Opticks.*

Let us not therefore faint, or be weary in our journey, much less turn back or sit down in despair; but *press* cheerfully forward to the high mark of our calling. *Rogers.*

Here, Peascod, take my pouch, 'tis all I own, 'Tis my *pressmoney*.—Can this silver fail? *Gay.*

Excellent was the advice of Eliphaz to Job, in the midst of his great troubles and *pressures*: acquaint thyself now with God, and be at peace. *Atterbury.*

They kept their cloaths, when they were not worn, constantly in a *press* to give them a lustre. *Arbuthnot.*

The blood flows through the vessels by the *excess* of the force of the heart above the incumbent *pressure*, which in fat people is excessive. *Id.*

I put pledgets of lint *pressed* out on the excoriation. *Wiseman.*

I am the more bold to *press* it upon you, because these accomplishments sit more handsomely on persons of quality than any other. *Felton.*

On superior powers Were we to *press*, inferior might on ours. *Pope.*

Leucothoe shook, And *pressed* Palemon closer in her arms. *Id.*

Through the *press* enraged Thalestris flies, And scatters death around from both her eyes. *Id.*

Those who negotiated took care to make demands impossible to be complied with; and therefore might securely *press* every article, as if they were in earnest. *Swift.*

You were *pressed* for the sea-service, and got off with much a-do. *Id.*

Of the stuffs I give the profits to dyers and *pressers*. *Id.*

While Mist and Wilkins rise in weekly might, Make *presses* groan, lead senators to fight. *Young.*

An Englishman fears contempt more than death, he often flies to death as a refuge from its *pressure*, and dies when he fancies the world has ceased to esteem him. *Goldsmith.*

This treatise he completed but did not publish; for that poverty which in our day drives authors as hastily in such numbers to the *press*, in the time of Ascham, I believe, debarred them from it. *Johnson.*

If, by the liberty of the *press*, we understand merely the liberty of discussing the propriety of public measures and political opinions, let us have so much of it as you please; but if it means the liberty of affroosting, calumniating, and defaming one another, I, for my part, own myself willing to part with my share of it whenever our legislators shall please to alter the law. *Franklin.*

**PRESS**, in the mechanic arts, is a machine made of iron or wood, serving to squeeze or compress any body very close. The ordinary presses consist of six members, or pieces; viz. two fat smooth planks, between which the things to be pressed are laid; two screws, or worms, fastened to the lower plank, and passing through two holes in the upper; and two nuts, in form of an S, serving to drive the upper plank, which is moveable, against the lower, which is stable, and without motion. Presses for expressing liquors are of various kinds; some in most respects the same with the common presses, excepting that the under plank is perforated with a great number of holes, to let the juice expressed run through into the tub, or receiver, underneath.

**PRESS, CUTTING, or BOOK-BINDER'S CUTTING-PRESS**, is a machine used equally by book-binders, stationers, and pasteboard makers; consisting of two large pieces of wood, in form of cheeks, connected by two strong wooden screws, which, being turned by an iron bar, draw together, or set asunder, the cheeks, as much as is necessary for the putting in the books or paper to be cut. The cheeks are placed lengthwise on a wooden stand, in the form of a chest, into which the cuttings fall. The cheeks are two pieces of wood, of the same length with the

**screws**, serving to direct the cheeks, and prevent their opening unequally. Upon the cheeks the plough moves, to which the cutting knife is fastened by a screw. The plough consists of several parts; a wooden screw or worm, catching within the nuts of the two feet that sustain it on the cheeks, brings the knife to the book or paper, which is fastened in the press between two boards. This screw, which is pretty long, has two directories, which resemble those of the screws of the press. To make the plough slide square and even on the cheeks, so that the knife may make an equal paring, that foot of the plough where the knife is not fixed slides in a kind of groove, fastened along one of the cheeks. Lastly, the knife is a piece of steel, six or seven inches long, flat, thin, and sharp, terminating at one end in a point, like that of a sword, and at the other in a square form, which serves to fasten it to the plough. See **BOOK-BINDING**. As the long knives used by us in the cutting of books or papers are apt to jump in the cutting thick books, the Dutch are said to use circular knives, with an edge all round; which not only cut more steadily, but last longer without grinding.

**PRESSING**, in the manufactures, is applied to cloth, stuff, &c., to render it smooth and glossy. There are two methods of pressing, viz. cold and hot. Cold-pressing is thus performed:—After the stuff has been scoured, fulled, and shorn, it is folded square in equal plaits, and a skin of vellum or pasteboard put between each plait. Over the whole is laid a square wooden plank, and so put into the press, which is screwed down tight by means of a lever. After it has lain a sufficient time in the press they take it out, removing the pasteboards, and lay it up to keep. Some only lay the stuff on a firm table, after plaiting and pasteboarding, cover the whole with a wooden plank, and load it with a proper weight. Hot-pressing is performed thus:—When the stuff has received the above preparations it is sprinkled a little with water, sometimes gum-water: then plaited equally, and between each two plaits are put leaves of pasteboard, and between every sixth and seventh plait, as well as over the whole, an iron or brass plate well heated in a kind of furnace. This done, it is laid upon the press, and forcibly screwed down. Under this press are laid five, six, &c., pieces at the same time, all furnished with their pasteboards and iron plates. When the plates are well cooled the stuffs are taken out, and stitched a little together to keep them in the plaits. This manner of pressing was only invented to cover the defects of the stuffs; and, accordingly, it has been frequently prohibited.

**PRESTEIGN**, a market town of Radnorshire, 149 miles W. N. W. of London, in the direct road to Aberystwith. It is a neat well-built town, with clean and regular streets, and is the residence of many genteel families. It is seated on a gravelly soil on the banks of the Lug, at the head of a very fertile vale: the mountains on the west and north-west forming a kind of amphitheatre round it. The name in Welsh is *Slan-Andras*, from the church, which is dedicated to **St Andrew**. The town is divided into four wards, which have each separate jurisdictions,

Vol. XVIII.

officers, levies, &c. It is a borough by prescription, and is governed by a bailiff, annually elected and sworn in by a steward appointed by the crown. The living is a rectory and vicarage united, worth from £500 to £600 a year: the parish lying in two counties. It has an excellent free school, well endowed. The county hall, gaol, bridewell, and correction-house, are kept in it. It has a market on Saturday, and two fairs. Presteign is thirty miles W. N. W. of Worcester.

**PRESTER**, a meteor consisting of an exhalation thrown from the clouds downwards with such violence that it is set on fire by the collision. The word is Greek, *πρηστηρ*, the name of a kind of serpent; called also *dipsas*, to which this meteor is supposed to bear a resemblance. The prester differs from the thunderbolt in the manner of its inflammation, and in its burning and breaking every thing it touches with greater violence.

**PRESTER JOHN**, an appellation formerly given to an emperor of the Tartars, who was overcome by Jenghiz Khan A. D. 1201.

**PRESTIMONY**, in canon law, is derived a *præstatione quotidiana*; and is, by some, defined to be a kind of benefice, served by a single priest. Others say it is the incumbency of a chapel without any title or collation; such as are most of those in castles, where prayers or masses are said, and which are mere endowed oratories. Whence the term is also applied, in the Romish church, to certain perpetual offices bestowed on canons, religious, or others, for the saying of masses, by way of augmentation of their livings. Du Moulin calls it a profane benefice, which however, has a perpetual title, and an ecclesiastical office, with certain revenues attached to it; which the incumbent is allowed to sell, and which may be possessed without tonsure; such as the lay church-wardens of Notre Dame. He adds that, in propriety, the canopies of chapels are benefices of this nature.

**PRES'IO**, *n. s.* Ital. *presto*; Lat. *presto*. Quick; at once. A word used by those that show legerdemain.

*Presto!* begone! 'tis here again;

There's every piece as big as ten. *Swift.*

**PRESTON** (Thomas), LL. D., a dramatic writer and actor who flourished in the beginning of queen Elizabeth's reign. He was first admitted M. A. and fellow of King's College, Cambridge, and afterwards created LL. D. and elected master of Trinity Hall. In 1564, when the queen was entertained at Cambridge, Preston acted so well in the tragedy of Dido, a Latin piece written by John Ritwise, another fellow of the same college, that queen Elizabeth settled a pension of twenty pounds a year on him; a circumstance which Shakspeare is supposed to allude to, in his *Midsummer Night's dream*, Act 4th. He likewise attended and exhibited at Oxford, on the 6th of September 1566, with other eight Cantabrigians, when the queen visited that university. He also wrote a dramatic piece, in the ancient metre, entitled *Cambyzes King of Persia*.

**PRESTON**, a borough and market town of England, in Lancashire, seated on the Ribble, over which there is a handsome stone bridge. The

town is well built, and lighted with gas; having a handsome and convenient town hall. The church is spacious and handsome: there are two Roman Catholic chapels, and meeting-houses for all classes of dissenters. The new prison, built according to the plan of John Howard, is a large and commodious building. Here is also a dispensary, a free grammar school, and several public charity schools. It is governed by a mayor, recorder, aldermen, four subaldermen, seventeen common-council-men, and a town clerk. It returns two members to parliament, the right of election being in the inhabitants at large, being the only place in England where the members are returned by universal suffrage. The returning officers are the mayor and two bailiffs. The river here is navigable for small vessels only; and by canal navigation it has communication with most of the principal rivers in England. The cotton manufactories are carried on here extensively. Here is held a court of Chancery, and other offices of justice for the county palatine of Lancaster. It is noted for the defeat of the Scotch royalists under the duke of Hamilton in the reign of Charles I., as well as for that of the rebels in 1715, when they were all made prisoners, and sent up to London. It has a good market-place, large open streets, and markets on Wednesday and Friday. From Preston a Roman road, still distinctly visible in places, conducts to Ribchester, once a military station of that people. Its original designation has been a matter of much contention among antiquaries. Camden supposes it to have been the *Coccium* of Antoninus, and the *Rigodunum* of Ptolemy. Horsley was of the same opinion as to *Coccium*, but inclined to fix *Rigodunum* at Warrington. Mr. Whitaker, the historian of Manchester, contended that it was *Rerigonium* of Richard of Cirencester; but Dr. Whitaker, who last investigated the subject, appears to have clearly identified it with *Coccium*; and assigns its original establishment to *Agricola*. From the boldness and extent of its ramparts, and also from the number of altars, inscribed stones, earthen vessels, plates of copper, coins, and other relics found here, Ribchester is presumed to have been a station of more than ordinary magnitude and importance. That the Ribble was anciently navigable as high as this place is proved by the fact of many anchors having been dug up in the vicinity, as well as the hull of a ship larger than any that could now be floated above Preston. Preston lies twenty-one miles south of Lancaster, and 216 N. N. W. of London.

PRESTON, a town of Scotland, in Haddingtonshire, in the parish of Preston-Pans, seven miles west of Haddington; formerly noted for its fair, held on the second Thursday of October, called St. Jerome's fair, at which the travelling chapmen made their annual election.

PRESTON-PANS, a parish of Scotland, in East Lothian, so named from the above town and the salt-pans near it, on the east coast of the frith of Forth. The soil is loam, partly on clay and partly on a sandy bottom; and produces good crops of all the usual grain. There are ten salt-pans, of which six are wrought. The average quantity of salt made annually is 10,700 bushels

and four gallons. The total quantity delivered in five years, from 1787 to 1792, was 417,354 bushels five gallons.

PRESTON-PANS, a town in the above parish, built after the erection of the salt-pans, and named from them. It is a quarter of a mile north of Preston. It is a burgh of barony, and a port of the custom-house, eight miles east of Edinburgh, and nine and three-quarters north-west of Haddington. It received its charter of erection in 1617, by which Preston is included in its privileges. It is noted for its extensive manufactures particularly of salt, stone, and earthen-ware, and brick and tile. A manufacture of oil of vitriol, aqua-fortis, and spirit of salt is also carried on to a great extent; and the same company manufactures great quantities of Glauber's salts. On the east of the enclosures of Preston-Pans, on the 21st of September 1745, the forces under prince Charles Stuart obtained a victory over the royal forces under Sir John Cope. See GREAT BRITAIN.

PRESUME', <i>v. n.</i>	} Fr. <i>presumer</i> ; Lat. <i>presumo</i> . To suppose; assume; believe or affirm without proof; in- trude; attempt vainly, or arrogant- ly; taking on, upon and of before the object (the last improperly)
PRESUMABLY, <i>adv.</i>	
PRESUMER, <i>n. s.</i>	
PRESUMPTION,	
PRESUMPTIVE, <i>adj.</i>	
PRESUMPTUOUS,	
PRESUMPTUOUSLY, <i>adv.</i>	
PRESUMPTUOUSNESS, <i>n. s.</i>	ly; taking on, upon

presumably is without examination: presumer and presumption follow these senses: presumptive is, taken by supposition; confident; arrogant; also in law applied to the person who, if the ancestor should die immediately, would be his heir, but whose right of inheritance may be defeated by some nearer heir being born: presumptuous is arrogant; confident; irreverent toward sacred things: the adverb and noun substantive corresponding.

Keep back thy servant from *presumptuous sins*.

*Psalms.*

In this we fail to perform the thing, which God seeth meet, convenient, and good; in that we *presume* to see what is meet and convenient, better than God himself.

*Hooker.*

The sins whereinto he falleth are not *presumptuous*; but are ordinarily of weakness and infirmity.

*Perkins.*

*I presume,*

That as my hand has opened bounty to you,  
My heart dropped love; my power rained honour,  
more

*Shakespeare. Henry VIII.*

Let my *presumption* not provoke thy wrath;

For I am sorry, that with reverence  
I did not entertain thee as thou art.

*Shakespeare.*

*Presumptuous* priest, this place commands my patience.

*Id.*

There was a matter we were no less desirous to know, than fearful to ask, lest we might *presume* too far.

*Bacon.*

The boldness of advocates prevails with judges; whereas they should imitate God, who represseth the *presumptuous*, and giveth grace to the modest.

*Id. Essays.*

Heavy with some high minds is an overweight of obligation; otherwise great deservers do grow intolerable *presumers*.

*Wotton.*

Thou hast shewed us how unsafe it is to offend thee, upon *presumption* afterwards to please thee.

King Charles.

A tower whose top might reach to heaven, was a shameful arrogance, an impious *presumption*.

Bp. Hall.

It warns a warier carriage in the thing,  
Lest blind *presumption* work their ruining.

Daniel.

I entreat your prayers, that God will keep me from all premature persuasion of my being in Christ, and not suffer me to go on *presumptuously* or desperately in any course.

Hammond.

A *presumption* upon this aid was the principal motive for the undertaking.

Clarendon.

O much deceived, much failing, hapless Eve!

Of thy *presumed* return! event perverse! Milton.

I to the heav'nly vision thus *presumed*. Id.

God, to remove his ways from human sense,  
Placed heaven from earth so far, that earthly sight,  
If it *presume*, might err in things too high,  
And no advantage gain.

Id. Paradise Lost.

Their minds somewhat raised

By false *presumptuous* hope. Milton.

Authors *presumably* writing by common places, wherein, for many years, promiscuously amassing all that make for their subject, break forth at last into useless rhapsodies.

Brown.

Although in the relation of Moses there be very few persons mentioned, yet are there many more to be *presumed*.

Id.

There being two opinions repugnant to each other, it may not be *presumptive* or sceptical to doubt of both.

Id.

It being not the part of a *presumptuous*, but of a truly humble man to do what he is bidden, and to please those whom he is bound in duty to obey.

Kettlewell.

I had the *presumption* to dedicate to you a very unfinished piece.

Dryden.

The powers incensed

Punished his *presumptuous* pride,

That for his daring enterprise she died. Id.

*Presuming* of his force, with sparkling eyes,

Already he devours the promised prize. Id.

We commonly take shape and colour for so *presumptive* ideas of several species, that, in a good picture, we readily say this is a lion, and that a rose.

Locke.

He that would not deceive himself, ought to build his hypothesis on matter of fact, and not *presume* on matter of fact, because of his hypothesis.

Id.

Experience supplants the use of conjecture in the point: we do not only *presume* it may be so, but actually find it is so.

Government of the Tongue.

Do you, who study nature's works, decide,

Whilst I the dark mysterious cause admire;  
Nor into what the gods conceal, *presumptuously* enquire.

Addison's Remarks on Italy.

Though men in general believed a future state, yet they had but confused *presumptions* of the nature and condition of it.

Rogers.

Later *presumes* upon the gift of continency.

Atterbury.

Canst thou love

*Presumptuous* Crete, that boasts the tomb of Jove?

Pope.

Those at home held their immoderate engrossments of power by no other tenure than their own *presumptive* upon the necessity of affairs.

Swift.

Mark these, she says; these, summoned from afar,  
Begin their march to meet thee at the bar;  
There find a judge, inexorably just,  
And perish there, as all *presumption* must. Cowper.

The same estate may be frequently devised by the subsequent birth of nearer *presumptive* heirs, before it fixes upon an heir apparent. As if an estate is given to an only child, who dies: it may descend to an aunt, who may be stripped of it by an after-born uncle; on whom a subsequent sister may enter, and who will again be deprived of the estate by the birth of a brother, the heir apparent.

Judge Christian.

**PRESUPPOSE**, *v. a.* Fr. *presupposer*, *præ* and *suppose*. To suppose as previous; imply as antecedent.

In as much as virtuous life *presupposeth* life, in as much as to live virtuously it is impossible except we live; the first impediment, which we endeavour to remove, is penury and want of things without which we cannot live.

Hooker.

All kinds of knowledge have their certain bounds; each of them *presupposeth* many necessary things learned in other sciences, and known beforehand.

Id.

All things necessary to be known that we may be saved, but known with *presupposal* of knowledge concerning certain principles, whereof it receiveth us already persuaded.

Id.

**PRESURMISE**, *n. s.* *Præ* and *surmise*. Surmise previously formed.

It was your *presurmise*,

That, in the dole of blows, your son might drop.

Shakspeare.

**PRETEND** *v. a. & v. n.*

Fr. *pretendre*;

**PRETENCE**, *n. s.*

Latin, *pretendo*.

**PRETENDER**,

Used by Dryden

**PRETENDINGLY**,

literally for to hold

**PRETENSION**, *n. s.*

out; to simulate;

claim, taking to before the object: as a verb neuter, to put in a claim, true or false; presume an ability to a thing; profess *presumptuously*: a pretender is one who claims, and more commonly one who cannot prove or sustain a right: *pretendingly* is *presumptuously*; arrogantly: *pretension*, claim, false or true; fictitious appearance.

With flying speed and seeming great *pretence*

Came running in a messenger. Spenser.

In the great hand of God I stand, and thence

Against the undivulged *pretence* I fight

Of treasonous malice. Shakspeare. Macbeth.

This was but an invention and *pretension* given out by the Spaniards.

Bacon.

'Tis their interest to guard themselves from those riotous effects of *pretended* zeal, nor is it less their duty.

Decay of Piety.

But if to unjust things thou dost *pretend*,

Ere they begin let thy *pretensions* end. Denham.

So strong his appetite was to those executions he had been accustomed to in Ireland, without any kind of commission or *pretence* of authority.

Clarendon.

Spirits on our just *pretences* armed

Fell with us. Milton.

This let him know,

Lest wilfully transgressing he *pretend*

Surprisal. Id.

Warn all creatures from thee

Henceforth; lest that too heavenly form, *pretended*

To hellish falsehood, snare them. Id.

There is no security which men can yield comparable to that of an oath; the obligation whereof no man wilfully can infringe, without renouncing the fear of God, and any *pretence* to his favour.

Barrow.

Of the ground of redness in this sea are we not fully satisfied? For there is another red sea whose name we *pretend* not to make out from these principles. *Browne.*

He so much abhorred artifice and cunning, that he had prejudice to all concealments and *pretensions*. *Fell.*

This *pretence* against religion will not only be baffled, but we shall gain a new argument to persuade men over. *Tillotson.*

Lucagus, to lash his horses, bends  
Pronc to the wheels, and his left foot *pretends*.  
*Dryden.*

Let not Trojans, with a feigned *pretence*

Of proffered peace, delude the Latian prince. *Id.*

The prize was disputed only till you were seen; now all *pretenders* have withdrawn their claims. *Id.*

Men indulged those opinions and practices that favour their *pretensions*. *L'Estrange.*

Primogeniture cannot have any *pretence* to a right of solely inheriting property or power. *Locke.*

Despise not these few ensuing pages; for never was any thing of this *pretence* more ingeniously imparted. *Evelyn.*

Whatever victories the several *pretenders* to the empire obtained over one another, they are recorded on coins without the least reflection. *Addison.*

I have a particular reason to look a little *pretendingly* at present. *Collier on Pride.*

I should have dressed the whole with greater care; but I had little time, which I am sure you know to be more than *pretence*. *Wake.*

Are they not rich? what more can they *pretend*?  
*Pope.*

To just contempt ye vain *pretenders* fall,

The people's fable and the scorn of all. *Id.*

In those countries that *pretend* to freedom, princes are subject to those laws which their people have chosen. *Swift.*

The numerous *pretenders* to places would never have been kept in order, if expectation had been cut off. *Id.*

*Pretenders* to philosophy or good sense grow fond of this sort of learning. *Watts.*

**PRETERITION, n. s.** } Fr. *preterition*;

**PRETERITNESS.** } Lat. *preteritus*. The act of going past: the state of being past.

Had not he been a wise disciple, that should have envied the great favour done to Judas, and have stomached his own *preterition*? So foolish are they, who, measuring God's affection by temporal benefits, are ready to applaud prospering wickedness; and to grudge outward blessings to them which are incapable of any better. *Bp. Hall.*

We cannot conceive a *preteritness* still backwards, in infinitum, that never was present, as we can an endless futurity that never will be present; so that though one is potentially infinite, yet nevertheless the other is positively finite; and this reasoning doth not at all affect the eternal existence of the adorable divinity, in whose invariable nature there is no past nor future. *Bentley's Sermons.*

**PRETERITION, or PRETERMISSION,** in rhetoric, a figure whereby, in pretending to pass over a thing untouched, we make a summary mention thereof. I will not say he is valiant, he is learned, he is just, &c.

**PRETERLAPSED, adj.** Lat. *preterlapsus*. Past and gone.

We look with a superstitious reverence upon the accounts of *preterlapsed* ages. *Glanville's Sepsis.*

Never was there so much of either, in any *preterlapsed* age, as in this. *Walton.*

**PRETERLE'GAL, adj.** *Preter* and legal. Not agreeable to law.

I expected some evil customs *preterlegal*, and abuses personal, had been to be removed. *King Charles.*

**PRETERMIT, v. a.** Lat. *pretermitto*. To pass by.

The fees, that are termly given to these deputies for recompense of their pains, I do purposely *pretermit*; because they be not certain. *Bacon.*

**PRETERNATURAL, adj.** } *Preter* and  
**PRETERNATURALLY, adv.** } natural. Differ-  
**PRETERNATURALNESS, n. s.** } ent from what is  
natural; irregular: the adverb and noun substantive correspond.

Simple air, *preternatually* attenuated by heat, will make itself room, and break and blow up all that which resisteth it. *Bacon.*

That form which the earth is under at present is *preternatural*, like a statue made and broken again. *Burnet.*

We will enquire into the cause of this vile and *preternatural* temper of mind, that should make a man please himself with that which can no ways reach those faculties which nature has made the proper seat of pleasure. *South's Sermons.*

Anger and the thirst of revenge are a kind of fever: fighting and law-suits bleeding; at least an evacuation. The latter occasions a dissipation of money; the former of those fiery spirits which cause a *preternatural* fermentation. *Shenstone.*

**PRETERPERFECT, adj.** Lat. *preteritum perfectum*. A grammatical term applied to the tense which denotes time absolutely past.

The same natural aversion to loquacity has of late made a considerable alteration in our language, by closing in one syllable the termination of our *preterperfect* tense, as drown'd, walk'd, for drowned, walked. *Addison's Spectator.*

**PRETEXT, n. s.** Fr. *pretexte*; Lat. *pretextus*. Pretence; false appearance, or allegation.

My *pretext* to strike at him admits

A good construction. *Shakspeare. Coriolanus.*

He made *pretext*, that I should only go  
And help convey his freight; but thought not so. *Chapman.*

I shall not say with how much or how little *pretext* of reason they managed those disputes. *Decay of Piety.*

Under this *pretext*, the means he sought

To ruin such whose might did much exceed

His power to wrong. *Daniel's Civil War.*

As chymists gold from brass by fire would draw,

*Pretexts* are into treason forged by law. *Denham.*

They suck the blood of those they depend upon,  
under a *pretext* of service and kindness.

*L'Estrange.*

**PRETEXTA TOGA.** See **PRETEXTA.**

**PRETI** (Chevalier Matthias), a celebrated Italian painter, born at Calabria in 1613. His picture of the triumph of Osiris, the Egyptian conqueror, obtained the prize from the Academy of St. Luke at Rome. He died in 1699.

**PRETOR, n. s.** } Fr. *pretour*; Lat. *pretor*.

**PRETORIAN, adj.** } The Roman judge; some times taken for a mayor: judicial.

Good Cinna, take this paper;

And look you lay it in the *pretor's* chair. *Shakspeare.*

The chancery had the *pretorian* power for equity; the star-chamber had the censorian power for offences. *Bacon.*

*Porphyrus*, whom *you* Egypt's *pretor* made, is come from Alexandria to your aid. *Druiden.*

An *advocate*, pleading the cause of his client before one of the *pretors*, could only produce a single witness, in a point where the law required two. *Spectator.*

**PRETOR.** See **PRÆTOR.**

**PRETSCHINSTANSKOE KREPOST**, a fortress in the government of Orenbourg, European Russia, on the Sacmara, and the principal of the line of forts on that river. The town is inhabited by Tartars. The preparation of birch tar is here a considerable employment.

**PRETTY**, *adj. & adv.* } Sax. *præte*; Belg. *prætily*, *adv.* } *fruit*; i. e. Goth. *frida*, *prytina*, *n. s.* } *pryda*. Neat; pleasing; elegant; beautiful or elegant without grandeur; used as a diminutive, contemptuously, and for a small, but not extremely small, number: as an adverb, in some degree: prettily is neatly; elegantly: prettiness follows the senses of the adjective and adverb.

How prettily the young swain seems to wash  
The hand was fair before. *Shakespeare. Winter's Tale.*

Of these the idle Greeks have many pretty tales. *Raleigh.*

Cut off the stalks of cucumbers, immediately after their bearing, close by the earth, and then cast a pretty quantity of earth upon the plant, and they will bear next year before the ordinary time. *Bacon.*

One saith prettily; in the quenching of the flame of a pestilent ague, nature is like people that come to quench the fire of a house; so busy, as one letteth another. *Id.*

A knight of Wales, with shipping and some pretty company, did go to discover those parts. *Abbot.*

There is goodness in the bodies of animals, as in the ox, greyhound, and stag; or majesty and stateliness, as in the lion, horse, eagle, and cock; grave awfulness, as in mastiffs; or elegancy and prettiness, as in lesser dogs and most sort of birds; all which are several modes of beauty. *More.*

Of this mixture we put a parcel into a crucible, and suffered it for a pretty while to continue red hot. *Boyle.*

Those drops of prettiness, scatteringly sprinkled amongst the creatures, were designed to defecate and craft our conceptions, not to inveigle or detain our passions. *Id.*

A pretty task; and so I told the fool,  
Who needs must undertake to please by rule. *Druiden.*

A weazle, a pretty way off, stood leering at him. *L'Ettrange.*

Children, kept out of ill company, take a pride to behave themselves prettily, after the fashion of others. *Locke.*

The world began to be pretty well stocked with people, and human industry drained those unhabitable places. *Burnet.*

The pretty gentleman is the most complaisant creature in the world, and is always of my mind. *Spectator.*

He'll make a pretty figure in a triumph,  
And serve to trip before the victor's chariot. *Addison.*

I shall not enquire how far this lofty method may advance the reputation of learning; but I am pretty sure 'tis no great addition to theirs who use it. *Collier.*

These colours were faint and dilute, unless the light was trajected obliquely; for by that means they became pretty vivid. *Newton.*

This writer every where insinuates, and, in one place, pretty plainly professes himself a sincere Christian. *Atterbury.*

The copper halfpence are coined by the publick, and every piece worth pretty near the value of the copper. *Swift.*

They found themselves involved in a train of mistakes, by taking up some pretty hypothesis in philosophy. *Watts.*

The first attempts of this kind were pretty modest. *Baker.*

**PREVAIL'**, *v. n.* } *Fr. prevailoir*; *Lat. prevailere*. To have power or effect; overcome; gain superiority; persuade; induce; gain influence: **PREVAILING**, *adj.* } **PREVAILMENT**, *n. s.* } **PREVALENCE**, or **PREVALENCY**, *n. s.* } **PREVALENT**, *adj.* } **PREVALENTLY**, *adv.* } prevailing is, dominant; efficacious; having most influence: prevailment, prevalence, and prevalency, predominance; influence; power; superiority; efficacy: prevalent and prevalently correspond.

With minds obdurate nothing *prevaieth*; as well they that preach, as they that read unto such, shall still have cause to complain with the prophets of old, Who will give credit unto our teaching? *Hooker.*

They that were your enemies, are his,  
And have prevailed as much on him as you. *Shakespeare.*

**Messengers**

Of strong *prevailment* in unhardened youth. *Id.*  
Brennus told the Roman ambassadors that *prevailent* arms were as good as any title, and that valiant men might account to be their own as much as they could get. *Raleigh.*

Nor is it hard for thee to preserve me amidst the unjust hatred and jealousy of too many, which thou hast suffered to prevail upon me. *King Charles.*

The millennium *prevailed* long against the truth upon the strength of authority. *Decay of Piety.*

I do not pretend that these arguments are demonstrations of which the nature of this thing is not capable: but they are such strong probabilities, as ought to prevail with all those who are not able to produce greater probabilities to the contrary. *Wilkins.*

He was prevailed with to restrain the earl of Bristol upon his first arrival. *Clarendon.*

The duke better knew what kind of arguments were of prevalence with him. *Id.*

Animals, whose forelegs supply the use of arms, hold, if not an equality in both, a *prevaleNCY* oft-times in the other. *Browne.*

The serpent with me  
Persuasively has so prevailed, that I  
Have also tasted. *Milton.*

On the foughten field,  
Michael and his angels *prevailent* encamping. *Id.*

This custom makes the short-sighted bigots, and the warier scepticks, as far as it *prevails*. *Locke.*

They are more in danger to go out of the way, who are marching under the conduct of a guide, than it is an hundred to one will mislead them, than he that has not yet taken a step, and is likelier to be prevailed on to enquire after the right way. *Id.*

Probabilities, which cross men's appetites and prevailing passions, run the same fate: let never so much probability hang on one side of a covetous man's reasoning, and money on the other, it is easy to foresee which will outweigh. *Id.*

... your assurance of merit, he indeed was prevailed  
to do so, and her forces took that expedition.

The conduct of a peculiar providence made the in-  
struments of that great design *prevail* and victo-  
rious, not all those mountains of opposition to be-  
come plains.

Save the friendless infants from oppression :  
Spirits shall assist thee with *prevailing* prayers,  
And warring angels combat on thy side.

The gods pray  
He would resume the conduct of the day,  
Nor let the world be lost in endless night ;  
*Prevailed* upon at last, again he took  
The harnessed steeds, that still with horror shook.

Why, fair one, would you not rely  
On reason's force with beauty's joined ?  
Could I their *prevailance* deny,  
I must at once be deaf and blind.

The evening star so falls in the main,  
To rise at morn more *prevailently* bright.  
This was the most received and *prevailent* opinion,  
when I first brought my collection up to London.

Least of all does this precept imply, that we should  
comply with any thing that the *prevailance* of corrupt  
fashion has made reputable.

While Marlbro's cannon thus *prevails* by land,  
Britain's sea chiefs by Anna's high command,  
Resistless o'er the Tuscan billows rise.

This song could *prevail*  
O'er death and o'er hell,  
A conquest how hard and how glorious !  
This kingdom could never *prevail* against the united  
power of England.

**PREVARICATE, v. a.** Fr. *prevariquer* ;  
**PREVARICATION, n. s.** Lat. *prevaricatio*. To  
cavil ; quibble ; scuffle ; quibbling ; shuffling ;  
cavil.

Laws are either *disannulled* or quite *prevaricated*  
through change and alteration of times, yet they are  
good in themselves.

Whoever helped him to this citation, I desire he  
will never trust him more : for I would think better  
of himself, than that he would wilfully *prevaricate*.

He *prevaricates* with his own understanding, and  
cannot seriously consider the strength, and discern  
the evidence of argumentations against his desires.

Several Romans, taken prisoners by Hannibal,  
were released upon obliging themselves by an oath to  
return again to his camp ; among these was one, who,  
thinking to elude the oath, went the same day back  
to the camp, on pretence of having forgot something ;  
but this *prevarication* was so shocking to the Roman  
senate, that they ordered him to be delivered up to  
Hannibal.

**PREVARICATION**, in the civil law, is where the  
informer colludes with the defendants, and so  
makes only a sham prosecution.

**PREVENE, v. a.** Lat. *prevenio*. To  
**PREVENIENT, adj.** go before ; hinder ;  
**PREVENT, v. a. & v. n.** be before ; anticip-  
**PREVENTER, n. s.** pate ; preoccupy :  
**PREVENTION, n. s.** the two active  
**PREVENTIVE, adj. & n. s.** verbs are both of  
**PREVENTIVE, adv.** this signification :

... with a nervous fever,  
... 9th of April 1791.

... a sister and two nephews,  
... the sciences,  
... collection of them to the best  
... Dr. Kippis, in his  
... observes, that in conse-  
... knowledge in mathe-  
... was qualified at a partic-  
... regular utility to his  
... number of schemes for  
... benefit of survivor-  
... advantages, were rising  
... These numerous schemes would  
... had not Dr.  
... dispelled the delu-  
... In this scheme of the  
... When the earl of  
... he sought the  
... a scheme for  
... moved an in-  
... that subject in the house  
... given from office  
... It was, however,  
... Dr. Price to a  
... of the Public Debts  
... Preliminary Articles  
... with a Plan for  
... and for redem-  
... After this, when Mr.  
... a bill into particu-  
... he applied  
... and received from  
... one of which, said by  
... in its operation,  
... though without the  
... of his obligations.

... In 1753 or 1754 he was  
... largely to the  
... in 1769 he  
... a diploma creating him  
... LL.D. was  
... by the college of Yale in  
... a Review of the  
... in Ministry,  
... the

... The Reg  
... F

... Pi  
... pre  
... In  
... what  
... their

... H  
... I  
... P  
... God  
... T  
... to ;  
... bes

... The Reg  
... F

... Pi  
... pre  
... In  
... what  
... their

... H  
... I  
... P  
... God  
... T  
... to ;  
... bes

... The Reg  
... F

... Pi  
... pre  
... In  
... what  
... their

... H  
... I  
... P  
... God  
... T  
... to ;  
... bes

... The Reg  
... F

... Pi  
... pre  
... In  
... what  
... their

... H  
... I  
... P  
... God  
... T  
... to ;  
... bes

... The Reg  
... F

... Pi  
... pre  
... In  
... what  
... their

... H  
... I  
... P  
... God  
... T  
... to ;  
... bes

They had horsemen, *prickers* as they are termed, fitter to make excursions and to chase, than to sustain any strong charge.

*Hayward.*

For long shooting, their shaft was a cloth yard, their *pricks* twenty-four score; for strength, they would pierce any ordinary armour.

*Carew*

If God would have had men live like wild beasts, he would have armed them with horns, tusks, talons, or *pricks*.

*Bramhall.*

Before each van

*Prick* forth the airy knights.

*Milton.*

They their late attacks decline,

And turn as eager as *pricked* wine.

*Hudibras.*

No asps were discovered in the place of her death, only two small insensible *pricks* were found in her arm.

*Browne.*

His rough crest he rears,

And *pricks* up his predestinating ears.

*Dryden.*

In this king Arthur's reign,

A lusty knight was *pricking* o'er the plain.

*Id.*

I no more

Shall see you browsing, on the mountain's brow,

The *prickly* shrubs.

*Id.*

The man who laughed but once to see an ass Mumbling to make the cross-grained thistles pass, Might laugh again, to see a jury chaw

The *prickles* of unpalatable law.

*Id.*

A fox catching hold of a bramble to break his fall, the *prickles* ran into his feet.

*L'Estrange.*

A taylor and his wife quarrelling, the woman in contempt called her husband *pricklouse*.

*Id.*

*Pricker* is vulgarly called an awl; yet, for joiners' use, it hath most commonly a square blade.

*Moxon's Mechanical Exercises.*

*Prickpunch* is a piece of tempered steel, with a round point at one end, to *prick* a round mark in cold iron.

*Moxon.*

A greyhound hath *pricked* ears, but those of a round hang down; for that the former hunts with his ears, the latter only with his nose.

*Grew.*

I caused the edges of two knives to be ground truly strait, and *pricking* their points into a board, so that their edges might look towards one another, and, meeting near their points, contain a rectilinear angle, I fastened their handles together with pitch, to make this angle invariable.

*Newton.*

The tuneful noise the sprightly courser hears,

Draws the green turf, and *pricks* his trembling ears.

*Gay.*

If she *pricked* her finger, Jack laid the pin in the

*Arbuthnot's John Bull.*

Keep close to ears, and those let asses *prick*;

Nothing, nothing; if they bite and kick.

*Pope.*

His high courage *pricked* him forth to wed.

*Id.*

How did the humble swain detest

His *prickly* beard, and hairy breast!

*Swift's Miscellanies.*

A buck is called the first year a fawn, the second year a *pricket*.

*Manwood.*

The flower's divine, where'er it grows;

Collect the *prickles*, and assume the rose.

*Watts.*

*PRIDE*, *n. s. & v. a.* Sax. *ppre* or *ppryð*;

*pryd*; Goth. *pried*. Inordinate self-

love; ostentation; splendor; exultation;

pride; elevation; dignity of manner: to

be proud; rate one's-self high.

The lofty trees,yclad with summer's *pride*,

And so broad, that heaven's light did hide.

*Spenser.*



Upon assurances of revolt, the queen was prevailed with to send her forces upon that expedition.

The conduct of a peculiar providence made the instruments of that great design *prevolent* and victorious, and all those mountains of opposition to become plains.

Save the friendless infants from oppression; Saints shall assist thee with prevailing prayers, And warring angels combat on thy side.

He would resume the conduct of the day, Nor let the world be lost in endless night; Prevailed upon at last, again he took The harnessed steeds, that still with horror shook.

Why, fair one, would you not rely On reason's force with beauty's joined? Could I their prevalence deny, I must at once be deaf and blind.

The evening star so falls in the main, To rise at morn more prevalently bright. This was the most received and prevalent opinion, when I first brought my collection up to London.

Least of all does this precept imply, that we should comply with any thing that the prevalence of corrupt fashion has made reputable.

While Marlbro's cannon thus prevails by land, Britain's sea chiefs by Anna's high command, Resistless o'er the Tuscan billows rise.

This song could prevail O'er death and o'er hell,

A conquest how hard and how glorious! This kingdom could never prevail against the united power of England.

Prevail upon some judicious friend to be your constant hearer, and allow him the utmost freedom.

PREVARICATE, *v. n.* } Fr. *prevariquer*;  
PREVARICATION, *n. s.* } Lat. *prævarico*. To cavil; quibble; shuffle: quibbling; shuffling; cavil.

Laws are either disannulled or quite *prevaricated* through change and alteration of times, yet they are good in themselves.

Whoever helped him to this citation, I desire he will never trust him more; for I would think better of himself, than that he would wilfully *prevaricate*.

He *prevaricates* with his own understanding, and cannot seriously consider the strength, and discern the evidence of argumentations against his desires.

Several Romans, taken prisoners by Hannibal, were released upon obliging themselves by an oath to return again to his camp: among these was one, who, thinking to elude the oath, went the same day back to the camp, on pretence of having forgot something; but this *prevarication* was so shocking to the Roman senate, that they ordered him to be delivered up to Hannibal.

PREVARICATION, in the civil law, is where the informer colludes with the defendants, and so makes only a sham prosecution.

PREVENE', *v. a.* } Lat. *prævenio*. To  
PREVIENT, *adj.* } go before; hinder;  
PREVENT', *v. a. & v. n.* } be before; anticipa-  
PREVENTER, *n. s.* } pate; preoccupy  
PREVENTION, } the two active  
PREVENTIVE, *adj. & n. s.* } verbs are both of  
PREVENTIVELY, *adv.* } this signification:

previent is, preceding; going before, hindering: prevent as a verb neuter is used by Bacon for to come after the time: preventer is either one who goes before or one who hinders: prevention, the act of preceding or hindering; anticipation; preoccupation; obstruction: preventive, hindering ill or good, taking of before the object: the adverb corresponds in sense.

Prevent him with the blessings of goodness.

Mine eyes prevent the night-watches, that I might be occupied in thy words.

Let thy grace, O Lord, always prevent and follow us.

Are we to forsake any true opinion, or to shun any requisite action, only because we have in the practice thereof been prevented by idolaters?

I do find it cowardly and vile, For fear of what might fall, so to prevent The time of life. Achievements, plots, orders, preventions, Success or loss.

The same officer told us he came to conduct us, and that he had prevented the hour, because we might have the whole day before us for our business.

Strawberries watered with water, wherein hath been steeped sheep's dung, will prevent and come early.

The archduke was the assailant and the preventer, and had the fruit of his diligence and celerity.

The greater the distance, the greater the prevention; as in thunder, where the lightning precedeth the crack a good space.

Wars preventive upon just fears are true defences, as well as upon actual invasions.

Thou hast prevented us with overtures of love, even when we were thine enemies.

Nothing engendered doth prevent his meat: Flies have their tables spread ere they appear; Some creatures have in winter what to eat; Others do sleep.

God's preventions, cultivating our nature, and fitting us with capacities of his high donatives.

From the mercy seat above Prevenient grace, descending, had removed The stony from their hearts, and made new flesh Regenerate grow instead.

This your sincerest care could not prevent, Foretold so lately what would come to pass.

Half way he met His daring foe, at this prevention more Incensed.

Physick is curative or preventive of diseases; preventive is that which, by purging noxious humours preventeth sickness.

In reading what I have written, let them bring no particular gusto, or any prevention of mind, and that whatsoever judgment they make, it may be purely their own.

If thy indulgent care Had not prevented, among unbodied shades I now had wandered. Prevention of sin is one of the greatest mercies God can vouchsafe.

Too great confidence in success is the likeliest to prevent it; because it hinders us from making the best use of the advantages which we enjoy.

Procuring a due degree of sweat and perspiration,  
is the best preventive of the gout. *Arbuthnot.*

Soon thou shalt find, if thou but arm their hands,  
Their ready guilt preventing thy commands;  
Could'st thou some great proportioned mischief  
frame,

They'd prove the father from whose loins they came.  
*Pope.*

**PREVESA**, a sea-port of Albania, situated at the entrance of the gulf of Arta. It has to the north a fine plain, containing a number of olive plantations, studded with well-built houses. To the west the ground rises, and renders the shore difficult of access. The inhabitants, chiefly Greeks, enjoy certain privileges, in consequence of stipulations between Great Britain and the Porte. Prevesa is built out of the ruins of the ancient Nicopolis, situated at a small distance to the north. It has a small harbour called Vathi, and carries on a good traffic in wood, oil, and fruit. Long one of the colonial possessions of Venice, this place was ceded to the Turks at the peace of Passarowitz in 1718, and remained in their hands until 1798, when it was occupied by the French. The following year it was taken by Ali Pacha, and a part of the inhabitants cruelly massacred. Population about 8000. Forty-five miles south by west of Joannina.

**PREVIOUS**, *adj.* } Lat. *prævius*. Antecedent;  
**PREVIOUSLY**, *adv.* } dent; going before; prior:  
antecedently.

By this *previous* intimation we may gather some  
lopes, that the matter is not desperate. *Burnet.*

Darting their stings, they *previously* declare  
Designed revenge, and fierce intent of war.

It cannot be reconciled with perfect sincerity, as  
*previously* supposing some neglect of better informa-  
tion. *Fiddes.*

Sound from the mountain, *previous* to the storm,  
Rolls o'er the muttering earth. *Thomson.*

**PREVOT D'EXILES** (Anthony Francis), a learned French writer, born at Hesdin in Artois, in 1697. While he was in the convent of St. Germain he wrote the greatest part of the *Mémoires d'un Homme de Qualité*. In 1745 he composed his *Histoire Générale des Voyages*. Besides writing many other original pieces, he translated Richardson's *Clarissa Harlowe*, and Sir Charles Grandison, into French. In 1763 being attacked with an apoplectic fit in the forest of Chantilly, and being supposed dead, the curate of the parish ordered a surgeon to open his body, when the unfortunate victim of this rash operation cried out; but the wound was mortal. He only opened his eyes to behold his executioners, and to close them for ever.

**PREY**, *n. s. & v. a.* Fr. *proie*; Lat. *præda*.  
Something to be devoured or seized; food or  
wealth gotten by violence; plunder: to prey is,  
to feed or live by violence; rob; waste.

Hog in sloth, fox in stealth; lion in prey.

*Shakspeare.*

They pray continually unto their saint the com-  
monwealth, or rather not pray to her, but prey on  
her: for they ride up and down on her, and make  
her their boots. *Id.*

Jove venom first infused in serpents fell,  
Taught wolves to prey, and stormy seas to swell.

*Mary.*

A garrison supported itself, by the prey it took  
from the neighbourhood of Aylesbury. *Clarendon.*  
The whole included race his purposed prey.

*Milton.*

She sees herself the monster's prey,  
And feels her heart and entrails torn away.

*Dryden.*

There are men of prey, as well as beasts and  
birds of prey, that live upon, and delight in blood.

*L'Estrange.*

Language is too faint to show  
His rage of love; it preys upon his life;  
He pines, he sickens, he despairs, he dies.

*Addison.*

Pindar, that eagle, mounts the skies,  
While virtue leads the noble way;  
Too like a vulture Boileau flies,  
Where sordid interest shews the prey. *Prior*  
Their impious folly dared to prey  
On herds devoted to the god of day. *Pope.*  
Who stung by glory, rave, and bound away;  
The world their field, and human-kind their prey.

*Young.*

Poor England! thou art a devoted deer,  
Beset with every ill but that of fear.  
Thee nations hunt; all mark thee for a prey;  
They swarm around thee, and thou stand'st at bay.

*Cowper.*

**PRIAM**, the last king of Troy, the son of Laomedon. He was carried into Greece after the taking of that city by Hercules; but was afterwards ransomed, on which he obtained the name of Priam, Πριαμος, Greek, signifying ransomed; his former name being Podarces. At his return he rebuilt Ilium, and extended the bounds of the kingdom of Troy, which became very flourishing under his reign. He married Hecuba, the daughter of Cisseus, king of Thrace, by whom he had nineteen children; and among the rest Paris, who carried off Helen, and occasioned the ruin of Troy, which is supposed to have been sacked by the Greeks about 1184 B. C., when Priam was killed by Pyrrhus the son of Achilles at the foot of an altar where he had taken refuge, after a reign of fifty-two years.

**PRIAPISM**, *n. s.* Fr. *priapisme*; Lat. *priapismus*. A preternatural tension.

Last causth a flagrancy in the eyes and priapism.

*Bacon.*

The person every night has a priapism in his sleep.

*Floyer.*

**PRIAPUS**. [Gr. Πρίαπος, item membrum virile; propter magnitudinem ejus cognominatus est Priapus.] In mythological painting and sculpture. The representations of this deity, held among the ancients to preside over gardens as well as over the genital parts of the sexes, are very numerous upon antique monuments, and are often found in situations which seem very inappropriate; whence it appears that the Greeks more particularly were apt to introduce and familiarise themselves with it. It is probable that they regarded the Priapus merely as an emblem of fecundity, and attached not to it (at least deemed it unnecessary to attach to it) any indecent or lascivious meaning. See **PHALLOS**. The original worshippers of this god, however (the people of Lampsacus), have been much belied if, in the festivals they held in his honor, they did not indulge in a good deal of lechituousness and impurity.

The representations of this nature which have a religious object are extremely numerous, and, as well as the worship of Priapus, have been treated of at a considerable length, and depicted in the rare work of Mr. Knight, entitled an Account of the Remains of the Worship of Priapus, to which is added a Discourse thereon, as connected with the Mystic Theology of the Ancients, London, 1786, 4to.

PRICE, *n. s. & v. a.* Fr. *prix*; Lat. *pratium*. Equivalent paid for any thing; value; rate of sale; reward: to pay for or estimate.

I will buy it of thee at a price; neither will I offer burnt offerings unto the Lord my God, of that which cost me nothing. 2 Samuel xxiv. 24.

Some shall pay the price of others guilt; And he the man that made sans foy to fall, Shall with his own blood price that he hath spilt.

*Spenser.*

We stand in some jealousy, lest by thus overvaluing their sermons; they make the price and estimation of scripture, otherwise notified, to fall.

*Hooker.*

From that which hath its price in composition, if you take away any thing, or any part do fail, all is disgrace.

*Bacon.*

If fortune has a niggard been to thee,

Devote thyself to thrift, not luxury;

And wisely make that kind of food thy choice,

To which necessity confines thy price. *Dryden.*

Supposing the quantity of wheat, in respect to its ent, be the same, that makes the change in the price of wheat. *Locke.*

Sometimes virtue starves, while vice is fed;

What then? is the reward of virtue bread?

That, vice may merit; 'tis the price of toil;

The knave deserves it, when he tills the soil. *Pope.*

PRICE (John), an English writer of great learning, who flourished in the seventeenth century. He resided several years at Paris, where he published some works, but returned to England in 1646. After travelling through various places, he settled at Florence, where he became a Roman Catholic, and the grand duke of Tuscany made him keeper of his medals, and professor of Greek. He published several works, in which he displayed great erudition; and died at Rome in 1676, or, as Dr. Watkins has it, in 1686.

PRICE (Rev. Richard), D. D., LL. D., and F. R. S. of London, was born at Tynton in Glamorganshire, February 22d, 1723. His father was a dissenting minister at Bridgend in that county, and died in 1739. His mother dying in 1740, he came to London and attended Mr. Eames's academy, under the patronage of his uncle, the Rev. S. Price, who was a colleague of Dr. Watts for forty years. In 1744 he went to reside with Mr. Streatfield of Stoke Newington as his domestic chaplain, while he also regularly assisted Dr. Chandler at the Old Jewry. Having lived with Mr. Streatfield nearly thirteen years, on his death he in 1757 married Miss S. Blundell of Leicestershire. He then settled at Hackney, but, being soon after chosen minister at Newington Green, he lived there until the death of his wife in 1786, when he returned to Hackney. He was next chosen afternoon preacher at the meeting house in Jewry Street, but this he resigned on being elected pastor of the gravel-pit meeting at Hackney. In Febru-

ary, 1791, he was attacked with a nervous fever, and the stone, and died the 19th of April, 1791. He left his property to a sister and two nephews. His universal acquaintance with the sciences, and his usual application of them to the best purposes, are well known. Dr. Kippis, in his address at his funeral, observes, that 'In consequence of his profound knowledge in mathematical calculations, he was qualified at a particular crisis for being of singular utility to his fellow citizens. A number of schemes for insurance for lives, and the benefit of survivorship, promising mighty advantages, were rising up in London. These ruinous schemes would have been carried to great excess had not Dr. Price stepped forward and dispelled the delusion.' With him Mr. Pitt's scheme of the sinking fund originated. When the earl of Shelburne was prime minister, he sought the assistance of Dr. Price in forming a scheme for paying off the national debt, and moved an introductory resolution on that subject in the house of lords; but upon his being driven from office the scheme was abandoned. It was, however, communicated to the public by Dr. Price in a treatise, entitled The State of the Public Debts and Finances, at signing the preliminary Articles of Peace in January 1783; with a Plan for raising Money by Public Loans, and for redeeming the Public Debts. After this, when Mr. Pitt determined to introduce a bill into parliament for liquidating the national debt, he applied to Dr. Price for his advice, and received from him three separate plans; one of which, said by the Dr. to be the least efficient in its operation, was adopted by the minister, though without the slightest acknowledgment of his obligations. See SINKING FUND. In 1763 or 1764 he was chosen F. R. S. and contributed largely to the transactions of that learned body; in 1769 he received from Aberdeen a diploma creating him D. D.; and in 1783 the degree of LL. D. was conferred upon him by the college of Yale in Connecticut. His works are, A Review of the Principal Question and Difficulties in Morals, 8vo., 1758; Dissertations on Providence, &c., 8vo., 1767; Observations on Reversionary Payments, &c., 8vo., 1771; Appeal on the National Debt, &c., 8vo., 1773; Observations on the Nature of Civil Liberty, 1776; on Materialism and Necessity, in a Correspondence between Dr. Price and Dr. Priestley, 1779; on Annuities, Assurances, Population, &c., 8vo., 1779; on the Population of England, 1780; on the Public Debts, Finances, Loans, &c., 8vo., 1783; on Reversionary Payments, 2 vols., 1783; on the Importance of the American Revolution, 1784; besides Sermons, and a variety of papers in the Philosophical Transactions, on astronomical and other philosophical subjects.

PRICK, <i>v. a., v. n. &amp;</i>	} Sax. <i>prican</i> ; Belg. <i>priken</i> ; Dan. <i>prikke</i> ;	
PRICK'ER, <i>n. s.</i> [ <i>n. s.</i> ]		
PRICK'ET,		Swed. <i>pricka</i> . To
PRICK'ITE,		puncture; pierce;
PRICK'LINESS,		spur; goad; form with
PRICK'LOUSE,		a point; fix by or hang
PRICK'LOUSE,		on a point; nominate
PRICK'LY, <i>adj.</i>	by a mark or puncture;	
PRICK'PUNCH, <i>n. s.</i>	note down with	

a style; mark a tune; to pain; pierce with anguish or remorse; make acid: as a verb center, come on the spur; dress or adorn for show: a prick is a sharp pointed instrument of any kind; the puncture, spot, or mark, made with such an instrument; a point; fixed place or point of time or attainment; print of a hare's foot; a painful or remorseful thought: pricker, synonymous with prick, an instrument; also (not in use) a light horseman: a pricket is a brack of the second year: prickle, a small sharp or thorny point: pricklouse, a foolish word of contempt for a tailor: pricksong, a song set to music: prickly, full of sharp points (prickliness corresponding): prickpunch is explained in the extract.

There shall be no more a *pricking* brier unto the house of Israel, nor any grieving thorn.

*Ezekiel* xxviii. 24.

When they heard this, they were *pricked* in their hearts, and said, Men and brethren, what shall we do?

*Acts* ii. 37.

It is hard for thee to kick against the *pricks*.

*Id.* ix. 5.

The cooks slice it into little gobbets, *prick* it on a prong of iron, and hang it in a furnace.

*Sandys*.

They had not ridden far, when they might see one *pricking* towards them with hasty heat.

*Spenser*.

Now grins this goodly frame of temperance

Fairly to rise, and her adorned head

To *prick* of highest praise forth to advance. *Id.*

Leave her to heaven,

And to those thorns that in her bosom lodge,

To *prick* and sting her. *Shakespeare. Hamlet.*

These many then shall die, their names are *prickt*.

*Shakespeare.*

Well, 'tis no matter, honour *pricks* me on;

But how if honour *pricks* me off, when

I come on. *Id. Henry IV.*

The country gives me proof

Of bellam beggars, who, with roaring voices,

Strike in their numbed and mortified bare arms

Pias, wooden *pricks*, nails, sprigs of rosemary.

*Shakespeare.*

My conscience first received a tenderness,

Scruple, and *prick*, on certain speeches uttered

By the bishop of Bayon. *Id. Henry VIII.*

Phaeton hath tumbled from his car,

And made an evening at the noon-tide *prick*.

*Shakespeare.*

I've called the deer, the princess killed a *pricket*.

*Id.*

He fights as you sing *pricksongs*, keeps time, distance, and proportion. *Id. Romeo and Juliet.*

The poets make Fame a monster; they say, look how many feathers she hath, so many eyes she hath underneath, so many tongues, so many voices, she *pricks* up so many ears. *Bacon.*

Some who are *pricked* for sheriffs, and are fit, set out of the bill. *Id.*

The *prickles* of trees are a kind of excrescence; the plants that have *prickles* are black and white, those have it in the bough; the plants that have *prickles* in the leaf are holly and juniper; nettles also have a small venomous *prickle*. *Id.*

Artichocks will be less *prickly* and more tender, if the seeds have their tops grated off upon a stone. *Id.*

If the English would not in peace govern them by the law, nor could in war root them out by the sword, must they not be *pricks* in their eyes, and thorns in their sides? *Durley.*

They had horsemen, *prickers* as they are termed, fitter to make excursions and to chase, than to sustain any strong charge. *Hayward.*

For long shooting, their shaft was a cloth yard, their *pricks* twenty-four score; for strength, they would pierce any ordinary armour. *Carew.*

If God would have had men live like wild beasts, he would have armed them with horns, tusks, talons, or *pricks*. *Bramhall.*

Before each van

*Prick* forth the airy knights. *Milton.*

They their late attacks decline,

And turn as eager as *pricked* wine. *Hudibras.*

No *asps* were discovered in the place of her death, only two small insensible *pricks* were found in her arm. *Browne.*

His rough crest he rears,

And *pricks* up his predestinating ears. *Dryden.*

In this king Arthur's reign,

A lusty knight was *pricking* o'er the plain. *Id.*

I no more

Shall see you browsing, on the mountain's brow, The *prickly* shrubs. *Id.*

The man who laughed but once to see an ass

Mumbling to make the cross-grained thistles pass,

Might laugh again, to see a jury chaw

The *prickles* of unpalatable law. *Id.*

A fox catching hold of a bramble to break his fall, the *prickles* ran into his feet. *L'Estrange.*

A taylor and his wife quarrelling, the woman in contempt called her husband *pricklouse*. *Id.*

*Pricker* is vulgarly called an awl; yet, for joiners' use, it hath most commonly a square blade. *Moxon's Mechanical Exercises.*

*Prickpunch* is a piece of tempered steel, with a round point at one end, to *prick* a round mark in cold iron. *Moxon.*

A greyhound hath *pricked* ears, but those of a hound hang down; for that the former hunts with his ears, the latter only with his nose. *Grew.*

I caused the edges of two knives to be ground truly strait, and *pricking* their points into a board, so that their edges might look towards one another, and, meeting near their points, contain a rectilinear angle, I fastened their handles together with pitch, to make this angle invariable. *Newton.*

The tuneful noise the sprightly courser hears, Paws the green turf, and *pricks* his trembling ears. *Gay.*

If she *pricked* her finger, Jack laid the pin in the way. *Arbuthnot's John Bull.*

Keep close to ears, and those let asses *prick*;

'Tis nothing, nothing; if they bite and kick. *Pope.*

His high courage *pricked* him forth to wed. *Id.*

How did the humble swain detest

His *prickly* beard, and hairy breast! *Swift's Miscellanies.*

The buck is called the first year a fawn, the second year a *pricket*. *Manwood.*

The flower's divine, where'er it grows;

Neglect the *prickles*, and assume the rose. *Watts.*

PRIDE, *n. s. & v. a.* Sax. *pryt* or *pryo*; Swed. *pryd*; Goth. *pried*. Inordinate self-esteem; ostentation; splendor; exultation; insolence; elevation; dignity of manner: to make proud; rate one's-self high.

Whose lofty trees,yclad with summer's *pride*, Did spread so broad, that heaven's light did hide. *Spenser.*

*Pride* hath no other glass

To shew itself, but *pride*; for supple knees

Feed arrogance, and are the proud man's fees. *Shakespeare.*

That which  
Hath wrought this hellish mischief unawares ;  
That hardly we escaped the *pride* of France. *Id.*  
God hath a special indignation at *pride* above all  
sins. *Bp. Hall.*

Vain aims, inordinate desires,  
Blown up with high conceits engend'ring *pride*.  
*Milton.*

Smallest lineaments exact,  
In all the liveries decked of summer's *pride*. *Id.*  
In this array the war of either side,  
Through Athens passed with military *pride*.  
*Dryden.*

The honest *pride* of conscious virtue. *Smith.*  
He could have made the most deformed beggar as  
rich as those who most *pride* themselves in their  
wealth. *Government of the Tongue.*

Be his this sword,  
Whose ivory sheath, inwrought with curious *pride*,  
Adds graceful terror to the wearer's side. *Pope.*  
This little impudent hardwareman turns into ri-  
dicule the direful apprehensions of the whole king-  
dom, *priding* himself as the cause of them.  
*Swift's Miscellanies.*

Though various foes against the truth combine,  
*Pride* above all opposes her design ;  
*Pride* of a growth superior to the rest,  
The subtlest serpent with the loftiest crest,  
Swells at the thought, and, kindling into rage,  
Would hiss the cherub Mercy from the stage.  
*Cowper.*

Earthly things  
Are out the transient pageants of an hour ;  
And earthly *pride* is like the passing flower,  
That springs to fall, and blossoms but to die.  
*Kirke White.*

PRIDEAUX (Humphry), D. D., a learned  
divine, born at Padstow in Cornwall in 1648.  
Three years he studied at Westminster under  
Dr. Busby ; and then was removed to Christ  
Church, Oxford. Here he published, in 1676,  
his *Marmora Oxoniensia ex Aurundelianis, Sel-  
denianis, alisque conflata, cum perpetuo Com-  
mentario*. This introduced him to the lord  
chancellor Finch, afterwards earl of Nottingham,  
who, in 1679, presented him to the rectory of  
St. Clements, near Oxford, and in 1681 bestowed  
on him a prebend of Norwich. Some years  
after he was engaged in a controversy with the  
Papists, at Norwich, concerning the validity of  
the orders of the church of England, which  
produced his book upon that subject. In 1688  
he was installed in the archdeaconry of Suffolk ;  
to which he was collated by Dr. Lloyd, then  
bishop of Norwich. In 1691, upon the death of  
Dr. Edward Pococke, the Hebrew professorship  
at Oxford, being vacant, was offered to Dr.  
Prideaux, but he declined it. In 1697 he pub-  
lished his *Life of Mahomet*, and in 1702 was  
installed dean of Norwich. In 1710 he under-  
went the operation of lithotomy, which inter-  
rupted his studies for more than a year. Some  
time after his return to London he proceeded  
with his connexion of the History of the Old  
and New Testament. He died in 1724.

PRIDEAUX (John), D. D., a learned English  
prelate, born at Stowford in Devonshire in 1578.  
His father had a numerous family, and John  
applied for the office of parish-clerk at Ugborow  
and lost it : yet, by the generosity of a friend, he  
was sent to the university of Oxford ; where he  
succeeded Dr. Holland as master of Exeter

College, in which he took his degrees. He was  
also regius professor of divinity, and vice-chan-  
cellor. In 1641 he was made bishop of Wor-  
cester, but was plundered soon after, during the  
troubles that followed, for having excommuni-  
cated those who had taken up arms against the king.  
He died in 1650. His principal works are, 1. *Ora-  
tiones inaugurales*. 2. *Lectiones decem de totidem  
Religionis Capitibus*. 3. *Fasciculus Controver-  
siarum*. 4. *Theologiæ Scholasticæ Syntagma  
Mnemonicum*. 5. *Sermons*, 4to. 6. *A Synop-  
sis of the Councils*. His son Matthias was born  
in 1622, and died in 1646. After his death was  
published, with his name, though supposed to  
be his father's, a work entitled *An easy and  
compendious Introduction for reading all sorts  
of Histories*, 4to.

PRIE, *n. s.* An old name of privet.—John-  
son.

Lop poplar and sawlow, elme, maple, and *prie*,  
Well saved from cattle, till summer to lie. *Tusser.*

PRIEST, *n. s.* } Sax. *þneort* ; Fr. *prestre* ;  
PRIEST'RAFT, } a corruption of Gr. *πρεσ-*  
PRIEST'ESS, } *βυρεος* ; the Span. retains  
PRIEST'HOOD, } *presbytero*. A minister of  
PRIEST'LY, *adj.* } religion offering sacrifices  
PRIEST'RIDDEN, } or prayers ; one of the  
second order of the English hierarchy : priest-  
craft is religious fraud ; art of wicked priests :  
priestess, a female who officiated in the heathen  
rites : priesthood, the office or order of priests :  
priestly, pertaining to, or becoming a priest :  
priest-ridden, managed or governed by priests.

The high *priest* shall not cover his head.

*Leviticus.*  
There were no *priests* and anti-*priests* in opposition  
to one another, and therefore there could be no schism.

*Lesley.*  
Jeroboam is reproved because he took the *priest-*  
*hood* from the tribe of Levi. *Whitgijfte.*

I'll to the vicar ;  
Bring you the maid, you shall not lack a *priest*.  
*Shakspeare.*

Our practice of singing differs from the practice  
of David, the *priests*, and Levites. *Peacham.*

These pray'rs I thy *priest* before thee bring.  
*Milton.*

He pretends that I have fallen foul on *priesthood*.  
*Dryden.*

How can incest suit with holiness,  
Or *priestly* orders with a princely state ? *Id.*

Puzzle has half a dozen common-place topics ;  
though the debate be about Douay, his discourse  
runs upon bigotry and *priestcraft*. *Spectator.*

These two, being the sons of a lady who was  
*priestess* to Juno, drew their mother's chariot to the  
temple. *Id.*

When too, our mighty sire, thou stood'st disarmed,  
When thy rapt soul the lovely *priestess* charmed  
That Rome's high founder bore. *Addison.*

In the Jewish church none that was blind or  
lame was capable of the *priestly* office.

*South's Sermons.*  
No neighbours, but a few poor simple clowns,  
Honest and true, with a well-meaning *priest*.  
*Rowe.*

The *priesthood* hath in all nations, and all religions,  
been held highly venerable. *Atterbury.*

From *priestcraft* happily set free,  
Lo ! ev'ry finished son returns to thee. *Pope*

The inferior *priestess*, at her altar's side,  
Trembling, begins the sacred rites of *pride*. *Id.*

Such a cant of high-church and persecution, and being *priestridden*.

Curanus is a holy priest, full of the spirit of the gospel, watching, labouring, and praying for a poor country village.

The state of parents is a holy state, in some degree like that of the *priesthood*, and calls upon them to bless their children with their prayers and sacrifices to God.

A PRIEST, in antiquity, was a person set apart for the performance of sacrifice, and other offices and ceremonies of religion. Before the promulgation of the law of Moses, the first born of every family, the fathers, the princes, and the kings, were priests. Thus Cain and Abel, Noah, Abraham, Melchizedec, Job, Isaac, and Jacob, offered their own sacrifices. Among the Israelites, after their exodus from Egypt, the priestly office was confined to one tribe; and it consisted of three orders, the high-priests, priests, and Levites. The priesthood was made hereditary in the family of Aaron; and the first-born of the oldest branch of that family, if he had no legal blemish, was always the high-priest. This divine appointment was observed with considerable accuracy till the Jews fell under the dominion of the Romans. Then, indeed, the high-priesthood was sometimes set up to sale; and instead of continuing for life, as it ought to have done, it seems to have been nothing more than a temporary office. There is sufficient reason, however, to believe that it was never disposed of but to some descendant of Aaron, capable of filling it had the older branches been extinct. In the time of David the inferior priests were divided into twenty-four companies, who were to serve in rotation, each company by itself, for a week. The order in which the several courses were to serve was determined by lot; and each course was in all succeeding ages called by the name of its original chief.

All nations have had their priests. The Pagans had priests of Jupiter, Mars, Bacchus, Hercules, Osiris and Isis, &c.; and some deities had priestesses. The Mahometans have priests of different orders, called mollah and mufti; and the Indians and Chinese have their brahmins and bonzes. The church of Rome, which holds the propitiatory sacrifice of the mass, has, of course, her proper priesthood. In the church of England, the word priest is retained to denote the second order in the hierarchy. Some few of her most eminent divines have maintained that the Lord's Supper is a commemorative and eucharistical sacrifice. These consider all who are authorised to administer that sacrament as in the strictest sense priests. Great numbers, however, of the English clergy, perhaps the majority, agree with the church of Scotland and with the Dissenters, in maintaining that the Lord's Supper is a rite of no other moral import than the commemoration of the death of Christ. These cannot consider themselves as priests in the rigid sense of the word, but only as presbyters, of which the word priest is a contraction of the same import with elder.

PRIESTLEY (Joseph), LL. D. F. R. S. and member of many foreign literary societies, was born March 13th, 1733, at Field-head, in Birstall parish, in the West Riding of Yorkshire.

His father was a manufacturer of cloth, and both his parents were persons of respectability among the Calvinistic Dissenters. Joseph was brought up, from an early period, in the house of Mr. Joseph Keighly, who had married his aunt. Showing an early fondness for reading, he was sent to a school at Batley, where he acquired a knowledge of the Latin, Greek, and Hebrew languages. In his nineteenth year he went to the academy at Daventry, where he became the first pupil of Dr. Ashworth, under whom he studied divinity. In 1755, his twenty-second year, he was chosen assistant minister to the Independent congregation of Needham Market, Suffolk; and at this time began to entertain Unitarian opinions. He also became a student and admirer of the metaphysical philosophy of Mr. Hartley, of which, during life, he continued the elucidator and advocate. In 1758 he was invited to be pastor of a congregation at Namptwich, in Cheshire; where he opened a school, exhibited philosophical experiments, and drew up an English Grammar, which was his first publication. Upon the death of the Rev. Dr. Taylor, tutor in divinity at Warrington Academy, Dr. Aikin being chosen to supply his place, Mr. Priestley was appointed to that of belles lettres in the doctor's room in 1761. He soon after married Mary, daughter of Mr. Wilkinson of Bersham, near Wrexham. Among the first of his publications at Warrington, were his *Chart of Biography*, and his *Chart of History*. He also published the substance of his *Lectures on General History and Politics*. He next published *Lectures on the Theory and History of Language*; and on the *Principles of Oratory and Criticism*. He next published his great work, the *History of Electricity*, wherein he gave an account of many of his own experiments. The first edition appeared at Warrington in 1767, 4to., and the fifth in 4to. in 1794. In 1768 he accepted of an invitation from a numerous and respectable congregation at Leeds. Here he published many tracts upon poetical theology, particularly, *Institutes of Natural and Revealed Religion*; and a *View of the Principles and Conduct of the Protestant Dissenters*. In these works he showed himself an open enemy to all unions of ecclesiastical with political systems. His next publication at Leeds was *The History and Present State of Discoveries relating to Vision, Light, and Colors*, 2 vols. 4to. 1772. About this period he began his celebrated experiments upon the atmospheric air. In 1770, through the recommendation of Dr. Price, the earl of Shelburne invited him to reside with him, as his librarian. At this time his family resided at Calne in Wilts, near Bowwood, lord Shelburne's seat. In 1773 he published his *Examination of Dr. Reid's Enquiry into the Human Mind*, of Dr. Beattie's *Essay on Truth*, and Dr. Oswald's *Appeal to Common Sense*. His object was to prepare the way for the *Hartleian Theory of the Human Mind*, which he next published, wherein he expressed his doubts of the immateriality of the soul: and in 1777, notwithstanding the obloquy occasioned by this work, he published *Disquisitions relating to Matter and Spirit*, in which he supported the

same doctrine. At this time also he stood forth as the champion of the philosophical doctrine of Necessity. As his friend, Dr. Price, differed from him on these two last mentioned points (as well as respecting the divinity of our Saviour), a correspondence relative to them took place, which was published in one volume. In the midst of these speculations, he carried on his experiments upon air with success, and enriched the science of chemistry with various discoveries.

About this period his Institutes of Religion were continued; his Letters to a Philosophical Unbeliever, and his Harmony of the Evangelists, and various similar tracts were published. The term of his engagement with lord Shelburne being concluded, and his lordship allowing him an annuity of £150, he took up his residence near Birmingham, not only on account of the advantage its manufactures afforded to his chemical pursuits, but also because of its being the residence of Messrs Watt, Bolton, Keir, Withering, and other eminent men of science. He was soon after invited to be pastor to a congregation of Dissenters at Birmingham, whom he found cordially attached to him. From the Birmingham press issued his Letters to Bishop Newcome on the Duration of Christ's Ministry; his History of the Corruptions of Christianity; and his History of Early Opinions Respecting Jesus Christ. Controversies now multiplied upon his hand. The disputes which took place upon the Dissenters' bill for relief from the test act furnished a new subject of contest; and he appealed to the people in his Familiar Letters to the Inhabitants of Birmingham. Previously to this Dr. Priestley had shown his attachment to freedom, by his Essay on the First Principles of Government, and by a pamphlet on the State of Public Liberty in this Country; and he had displayed a warm interest in the cause of America, when the disputes between Britain and her colonies broke out. The French Revolution was also viewed by him with satisfaction. His sanguine hopes, as well as those of many others, prognosticated from it the dawn of light and liberty throughout Europe; and he particularly expected from it the downfall of all ecclesiastical establishments. In this state of party exasperation, the celebration of the 14th of July, 1791, by a public dinner, at which Dr. Priestley was not present, afforded the signal for those savage riots which disgraced the town of Birmingham. Amidst the burning of chapels and private houses, Dr. Priestley was hunted like a proclaimed criminal; and his house, library, MSS. and chemical apparatus, were destroyed. Driven from his favorite residence, his losses were but poorly compensated. After passing some time as a wanderer, an invitation to succeed Dr. Price afforded him a new settlement at Hackney, where he expected to have ended his days in quiet; but he received an intimation of high authority that if he did not voluntarily leave the country the executive government would proceed against him. He therefore resolved to embark for America, and, accordingly, in 1794 arrived with his family at Northumberland, an inland town of Pennsylvania. In the

United States he was received with general respect; and was offered the place of Chemical Professor at Philadelphia, but declined it. Having collected a new apparatus and library, he resumed his experiments, and published the results in the American Philosophical Transactions, wherein he continued to defend the doctrine of Phlogiston to the last. He also published a comparison of the Jewish with Mahometan and Hindoo religions. He even commenced the printing of two extensive works; viz. a Church History, and an Exposition of the Scriptures; but did not live to finish them; though he urged it upon his surviving friends. He also composed, transcribed, and left in MS. ready for the press, A Comparison of the different Systems of Grecian Philosophy with Christianity. His health began to decline in 1801; but his intellectual powers continued unimpaired to the last; in so much that he dictated some corrections of his unfinished works the last day of his life. He died on the 9th of February, 1804, between eight and nine P. M. with much calmness. Dr. Aikin thus sums up his character:—'He was naturally disposed to cheerfulness. In large and mixed companies he usually spoke little. In his domestic relations he was uniformly kind and affectionate, and not malice itself could ever fix a stain on his private conduct, or impeach his integrity.'

**PRIG**, *n. s.* A cant word derived from prick; as, he pricks up, he is pert; or from prickeared, an epithet of reproach bestowed upon the presbyterian teachers of the commonwealth. A pert, conceited, pragmatical fellow.

The little man concluded, with calling monsieur Mesnager an insignificant *prig*. *Spectator.*

There have I seen some active *prig*,

To shew his parts, bstride a twig.

*Swift's Miscellanies.*

**PRILUKI**, a town of European Russia, in the government of Poltava. It stands on the river Udai, and has 2500 inhabitants, who carry on a traffic in corn, cattle, horses, and silk. Eighty miles S. S. E. of Czernigov, and 128 W. N. W. of Poltava.

**PRIM**, *adj.* By contraction from primitive. Formal; precise; affectedly nice.

A ball of new-dropt horse's dung

Mingling with apples in the throng,

Said to the pippin, plump and *prim*,

See, brother, how we apples swim.

*Swift's Miscellanies.*

**PRIME VIE**, in medicine, a name some times given to the whole alimentary canal.

**PRIMATE**, *n. s.* } *Fr. primat; Lat. primus.*  
**PRIMARY**. } A chief ecclesiastic: the station of a primate.

We may learn from the prudent pen of our most reverend *primate*, eminent as well for promoting unanimity as learning. *Holyday.*

When he had now the *primacy* in his own hand, he thought he should be to blame if he did not apply remedies. *Clarendon.*

When the power of the church was first established, the archbishops of Canterbury and York had then no pre-eminence one over the other; the former being *primate* over the southern, as the latter was over the northern parts. *Ayliffe.*

The late and present *primate*, and the lord archbishop of Dublin, have left memorials of their *soberly*.

*PRIMARY*, *adj.*

*PRIMAL*,

*PRIMARILY*, *adv.*

*PRIMARINESS*, *n. s.*

*PRIME*, *n. s.*, *adj.*, & *v. a.*

*PRIMELY*, *adv.*

*PRIME'NESS*, *n. s.*

*PRIMER*.

*Lat. primarius.*  
First; chief; principal: *primal* is a poetical word of the same signification: *primarily*, originally; in the first place: the noun substantive corresponding: *prime* is the first part of the day; the beginning; best or chief part; spring or height of life or health; spring of the year; height of perfection: as an adverb, early; principal; first rate; blooming; original: to *prime* is, apply the first coat of paint; put in first powder, or the powder into the pan of a gun: *primely* and *primeness* correspond with *prime*, as an adjective: *primer* is an obsolete word for first; original.

His 'larum bell might loud and wide be heard

When cause required, but never out of time;

Early and late it rung at evening and at *prime*.

*Spenser.*

Make haste, sweet love, while it is *prime*,

For none can call again the passed time. *Id.*

Quickly sundry arts mechanical were found out in the very *prime* of the world. *Hooker.*

Will she yet debase her eyes on me,

That crompt the golden *prime* of this sweet prince,

And made her widow to a woful bed? *Shakspeare.*

We smothered

The most replenished sweet work of nature,

That from the *prime* creation e'er she framed. *Id.*

We are contented with

Catharine our queen, before the *primest* creature

That's paragoned i' the world. *Id.*

It hath been taught us from the *primal* state,

That he, which is, was wished, until he were. *Id.*

Before that beginning, there was neither *primarily* matter to be informed, nor form to inform, nor any being but the eternal. *Ruleigh.*

As when the *primer* church her councils pleased

to call,

Great Britain's bishops there were not the least of all. *Drayton.*

The figurative notation of this word, and not the *primery* or literal, belongs to this place. *Hammond.*

Divers of *prime* quality, in several counties, were, for refusing to pay the same, committed to prison. *Clarendon.*

Sure pledge of day that crown'd the smiling morn

With thy bright circlet, praise him in thy sphere

While day arises, that sweet hour of *prime*. *Milton.*

Nor can I think that God will so destroy

Us his *prime* creatures dignified so high. *Id.*

Nature here wantoned as in her *prime*. *Id.*

In fevers, where the heart *primarily* suffereth, we apply medicines unto the wrists. *Broune's Vulgar Errors.*

The church of Christ, in its *primary* institution, was made to be of a diffusive nature, to spread and extend itself. *Pearson.*

Hope waits upon a flowery *prime*,

And summer, though it be less gay,

Yet is not looked on as a time

Of declination or decay. *Waller.*

A pistol of about a foot in length, we *primed* with well dried gunpowder. *Byble.*

Short were her marriage joys; for, in the *prime* of youth, her lord expired before his time. *Dryden.*

Humility and resignation are our *prime* virtues. *Id.*

Moses being chosen by God to be the ruler of his people, will not prove that priesthood belonged to Adam's heir, or the *prime* fathers. *Locke.*

These I call original or *primary* qualities of body, which produce simple ideas in us, viz. solidity, extension, figure and motion. *Id.*

That which is peculiar must be taken from the *primariness* and secondariness of the perception. *Norris.*

When the ruins both *primary* and secondary were settled, the waters of the abyss began to settle too. *Burnet.*

Words signify not immediately and *primely* things themselves, but the conceptions of the mind about them. *South.*

Nought treads so silent as the foot of time:

Hence we mistake our autumn for our *prime*. *Young.*

That little orb in days remote of old,

When angels yet were young, was made for man,

And titled earth, her *primal* virgin name. *Pollak.*

*PRIMATE* (*primas regni*, head of the kingdom);

in the European states, the chief archbishop in

the state, and the first subject of the realm; in

the Catholic church, the primate is also perpetual

legate of the pope, and has a sort of spiritual

jurisdiction over the other archbishops. There are

also primates of provinces. The archbishop of

Toledo is primate of Spain; the archbishop of

Braga is styled primate of Portugal, although

he is actually inferior to the patriarch of Lisbon.

In England, the archbishop of Canterbury is

styled primate of all England, and the arch-

bishop of York primate of England. In the

Irish church, the archbishop of Armagh is pri-

mate of all Ireland; the archbishop of Dublin

primate of Ireland; the archbishop of Cashel,

primate of Munster; and the archbishop of Tuam,

primate of Connaught. In the German empire,

the archbishop of Salsburgh was primate

of Germany. In France, the archbishop of

Lyons is primate of France; that of Bourges,

primate of Aquitania, and that of Rheims, of

Normandy. In Hungary, the archbishop of

Gran is primate; in Poland, the archbishop of

Gresen.

*PRIME*, in fencing, is the first of the chief guards. See *FENCING*.

*PRIME FIGURE*, in geometry, one which cannot be divided into any other figures more simple than itself, as a triangle among planes, and the pyramid among solids.

*PRIME VERTICAL* is that vertical circle which passes through the poles of the meridian, or the east and west points of the horizon; whence dials projected on the plane of this circle are called *prime vertical* or north and south dials.

*PRIMER, n. s.* A small prayer-book in which children were taught to read, so named from the Romish book of devotions; an elementary book; an office of the Virgin Mary.

Another prayer to her is not only in the manual, but in the *primer* or office of the blessed Virgin. *Stillingtonfleet.*

The Lord's prayer, the creed, and ten commandments he should learn by heart, not by reading them himself in his *primer*, but by somebody's repeating them before he can read. *Locke.*

*PRIMER SEASIN*, in feudal law, was a feudal burden, only incident to the king's tenants in



capite, and not to those who held of inferior or mesne lords.—It was a right which the king had when any of his tenants in capite died, seized of a knight's fee, to receive of the heir (provided he were of full age), one whole year's profits of the lands if they were in immediate possession, and half a year's profits if the lands were in reversion expectant on an estate for life. This seems to be little more than an additional relief, but grounded upon this feudal reason, that, by the ancient law of feods, immediately upon the death of a vassal, the superior was entitled to enter and take seisin or possession of the land, by way of protection against intruders, till the heir appeared to claim it, and receive investiture; and, for the time the lord so held it, he was entitled to take the profits; and, unless the heir claimed within a year and day, it was by the strict law a forfeiture. This practice, however, seems not to have long obtained in England, if ever, with regard to tenures under inferior lords; but, as to the king's tenures in capite, this prima seisin was expressly declared under Henry III. and Edward II. to belong to the king by prerogative, in contradistinction to other lords. And the king was entitled to enter and receive the whole profits of the land, till livery was sued; which suit being commonly within a year and day next after the death of the tenant, therefore the king used to take at an aveage the first-fruits, that is to say, one year's profits of the land. And this afterwards gave a handle to the popes, who claimed to be feudal lords of the church, to claim in like manner from every clergyman in England the first year's profits of his benefice, by way of primitiæ, or first fruits.—All the charges arising by primer seisin were abolished by 12 Car. II. c. 24.

**PRIME'RO**, *n. s.* Span. *primero*. A game at cards.

I left him at *primero*  
With the duke of Suffolk.

*Shakspeare. Henry VIII.*

**PRIME'VAL**, *adj.* } Lat. *primævus*. Ori-  
**PRIME'VOUS**. } ginal; such as was at first.  
All the parts of this great fabric change,  
Quit their old stations and *primeval* frame,  
And lose their shape, their essence, and their name.

*Prior.*

Immortal dove,  
Thou with almighty energy didst move,  
On the wild waves incumbent didst display  
Thy genial wings, and hatch *primeval* day.

*Blackmore.*

Thou, who didst put to flight  
*Primeval* silence, when the morning stars,  
Exulting, shouted o'er the rising ball.

*Young.*

**PRIMING**, among painters, signifies the laying on of the first color.

**PRIMING**, in gunnery, the train of powder that is laid, from the opening of the vent, along the gutter or channel on the upper part of the breech of the gun: which, when fired, conveys the flame to the vent, by which it is further communicated to the charge, in order to fire the piece. This is only used on shipboard at the proof, and sometimes in garrison; for, on all other occasions, tubes are used for that purpose.

**PRIMING WIRE**, in gunnery, a sort of iron needle employed to penetrate the vent or touch-

hole of a piece of ordinance when it is loaded, in order to discover whether the powder contained therein is thoroughly dry and fit for immediate service; as likewise to search the vent, and penetrate the cartridge, when the guns are not loaded with loose powder.

**PRIMIPILUS**, in antiquity, the centurion of the first cohort of a legion, who had the charge of the Roman eagle. This officer also went under the several titles of *dux legionis*, *præfectus legionis*, *primus centurionum*, and *primus centurio*; and was the first centurion of the *triarii* in every legion. He presided over all the other centurions, and generally gave the word of command by order of the tribunes. Having the care of the eagle, or chief standard of the legion, *aquilæ præesse* was used for the dignity of *primipilus*; and hence *aquila* is used by *Pliny* for that office. Nor was this station honorable only, but also very profitable; for he had a special stipend allowed him, and, when he left that charge, was reputed equal to the members of the equestrian order, bearing the title of *primipilarius*, as those who had discharged the greater civil offices were styled ever after *consulares*, *ensorii*, &c.

**PRIMITIÆ**, the first-fruits gathered of the earth, whereof the ancients made presents to the gods.

**PRIMITIVE**, *adj.* } Fr. *primitif*; Lat.  
**PRIM'ITIVELY**, *adv.* } *primitivus*. Ancient;  
**PRIM'ITIVENESS**, *n. s.* } original; from the  
beginning: formal; precisely grave: the adverb  
and noun substantive correspond.

Their superstition pretends, they cannot do God greater service than utterly to destroy the *primitive* apostolic government of the church by bishops.

*King Charles.*

The scripture is of sovereign authority, and for itself worthy of all acceptance. The latter, namely the voice and testimony of the *primitive* church, is a ministerial, and subordinate rule and guide, to preserve and direct us in the right understanding of the scriptures.

*White.*

Our *primitive* great sire to meet  
His godlike guest, walks forth.

*Milton.*

Solemnities and ceremonies, *primitively* enjoined, were afterward omitted, the occasion ceasing.

*Browne.*

The doctrine of purgatory, by which they mean an estate of temporary punishments after this life, was not known in the *primitive* church, nor can be proved from scripture.

*Tillotson.*

David reflects sometimes upon the present form of the world, and sometimes upon the *primitive* form of it.

*Burnet.*

The purest and most *primitively* reformed church in the world was laid in the dust.

*South.*

His memory was large and tenacious, yet, by a curious felicity, chiefly susceptible of the finest impressions it received from the best authors he read, which it always preserved in their *primitive* strength and amiable order.

*Johnson.*

**PRIMOGEN'IAL**, *adj.* } Lat. *primigenius*.  
**PRIMOGEN'ITURE**, *n. s.* } Firstborn; original;  
primary; constituent: primogeniture is seniority;  
eldership.

Are we so foolish, that, while we may sweetly enjoy the settled estate of our *primogeniture*, we will needs bring upon ourselves the curse of Reuben?

*Bp. Hall.*

The *primogenial* light at first was diffused over the face of the unfashioned chaos. *Glanville.*

Because the scripture affordeth the priority of order unto Shem, we cannot from hence infer his *primogeniture*. *Broune.*

It is not easy to discern, among many differing substances obtained from the same matter, what *primogenial* and simple bodies conjoined together compose it. *Boyle.*

The first or *primogenial* earth, which rose out of the chaos, was not like the present earth. *Burnet.*

The first provoker has by his seniority and *primogeniture* a double portion of the guilt.

*Government of the Tongue.*

**PRIMOGENITURE**, the right of the first born, has among most nations been very considerable. The first-born son in the patriarchal ages had a superiority over his brethren, and in the absence of his father was priest to the family. Among the Jews he was consecrated to the Lord, had a double portion of the inheritance, and succeeded in the government of the family or kingdom. But if a woman's first child was a girl, neither she, nor the children that came after her, were consecrated. In every nation of Europe, the right of primogeniture prevails in some degree at present, but it did not prevail always. The law which calls the first-born to the crown, preferably to the others, was unknown to the first race of French kings, and even to the second. It was not till the end of the tenth century, under the race of Hugh Capet, that the prerogative of succession to the crown was appropriated to the first-born. By the ancient custom of gavel-kind, still preserved in some parts of our island, primogeniture is of no account; the paternal estate being equally shared by all the sons. And it has been a matter of violent and learned dispute, whether, at the death of Alexander III. Baliol or Bruce was, by the law as it then stood, heir to the crown of Scotland. The former had undoubtedly the right of primogeniture, but the latter stood in one degree of nearer relation to the deceased sovereign; and the Scottish barons, not being able to determine whose claim was best founded, referred the question to Edward I. of England, and thereby involved their country in a long and ruinous war.

**PRIMORDIAL**, *adj.* Fr. *primordial*; Lat. *primordium*. Original; existing from the beginning.

The *primordials* of the world are not mechanical, but spiritual and vital. *More.*

Salts may be either transmuted or otherwise produced, and so may not be *primordial* and immutable beings. *Boyle.*

Not every thing chymists will call salt, sulphur, or spirit, that needs always be a *primordiate* and imperishable body. *Id.*

**PRIMORIE**, a hilly district of Austrian Dalmatia, between the Cetina and Neretva. It produces wine, oil, and figs. The chief town is Metkova. This district was called Dalmatia by the Romans, and by the Greeks Parathalassia. Inhabitants 15,000.

**PRIMROSE**, *n. s. & adj.* Lat. *primula veris*. A flower that appears early in the year: gay; *boisterous.*

I had thought to have let in some of all professions, that go the *primrose* way to the everlasting *bozire*. *Shakespeare.*

Pale *primroses*,

That die unmarried ere they can behold

Bright Phœbus in his stre:gh.

*Shakespeare. Winter's T. s.*

There followeth, for the latter part of *January*, *primroses*, anemones, the early tulip.

*Bacon's Essays.*

How pleasant thy banks and green valleys below,  
Where wild in the woodlands the *primroses* blow;  
There, oft as mild evening weeps over the lea,  
The sweet-scented birch shades my Mary and me.

*Burns.*

**PRIMROSE**, in botany. See **PRIMULA**.

**PRIMULA**, the primrose, a genus of the monogynia order, and pentandria class of plants; natural order twenty-first, *precia*. The involucre lies under a simple umbel; the tube of the corolla is cylindrical; with the mouth or limb patulous. This genus, including also the polyanthus and auricula, furnishes an excellent collection of low, herbaceous, flowery perennials.

1. *P. auricula* has a thick fibrous root, crowned by a cluster of oblong, fleshy, broad, serrated, smooth leaves, resembling the shape of a bear's ear; and amidst them upright flower stalks from about three or four, to six or eight, inches high, terminated by an umbellate cluster of beautiful flowers, of many different colors in the varieties. All of these have a circular eye in the middle of each flower, and of which there are different colors; whence the auriculas are distinguished into yellow-eyed, white-eyed, &c. The petals of most of the kinds are powdered with an exceedingly fine farina, which contributes greatly to the beauty of the flower. They all flower in April or May, continuing a month or six weeks in beauty, and ripening plenty of seeds in June.

2. *P. polyanthus* has thick fibrous roots, increasing into large bunches, crowned with a cluster of large oblong, indented, rough leaves; amidst them upright flower-stalks six or eight inches high, terminated mostly by a cluster of several spreading flowers of many different colors in the varieties. They all flower beautifully in April and May, and frequently again in autumn; and sometimes even in winter, if the season is mild. The polyanthus is one of the noted prize flowers among the florists; many of whom are remarkably industrious in raising a considerable variety of different sorts, as well as in using every art to make them blow with all requisite perfection. The chief properties required in a florist's polyanthus are—1. The stem or flower-stalk should be upright, moderately tall, with strength in proportion, and crowned by a good regular bunch of flowers on short pedicels, strong enough to support them nearly in an upright position. 2. The florets of each branch should be equally large, spreading open flat, with the colors exquisite, and the stripes and variegations lively and regular. 3. The eye in the centre of each floret should be large, regular, and bright; and the antheræ, by the florists called the thrum, should rise high enough to cover the mouth of the tube or hollow part in the middle of the florets, and render them what they call thrum-eyed; but, when the style elevates the stigma above the antheræ, the eye of the tube generally appears hollow, showing the stigma in the middle, like the head of a pin, and

is rejected as an incomplete flower, though its other properties should be ever so perfect. This pin-eyed polyanthus, however, though rejected by the florists, is the flower in its most perfect state, and great numbers of them are of as beautiful forms and colors as the thrum-eyed varieties.

3. *P. veris*, the spring primrose, has thick and very fibrous roots, crowned by a cluster of large oblong indented rough leaves, and numerous flower-stalks, from about three or four, to five or six, inches high; each terminated commonly by one flower. All the varieties flower abundantly in March and April, and continue for a month or six weeks. The cowslip primrose, or cowslip, or oxlip, has very thick fibrous roots, crowned by a cluster of oblong, indented, round, leaves, and upright, firm, flower-stalks five or six inches high, terminated each by a cluster of small flowers. They flower in April or May, continuing in succession a month or six weeks. All the varieties of the common spring primrose multiply so fast by the roots that it is scarcely worth while to raise them from seeds. However, though many single kinds may be raised from seed, yet parting the roots is the only method by which the double kind can be preserved; and the same thing is to be observed of all the rest.

PRINCE, *n. s. & v. n.* } Fr. *prince*; Lat. *prin-*  
 PRINCE'DOM, *n. s.* } *ceps*. A sovereign; a  
 PRINCE'LIKE, *adj.* } chief ruler of either  
 PRINCE'LY, } sex; the son of a king:  
 PRIN'CESS, *n. s.* } to play the prince:  
 princedom is the rank or state of a prince; Wicliff uses 'prynshood,' see the extract: prince-like, becoming a prince: princely, having the rank of princes; befitting that rank; royal; grand; sumptuous: princess, the feminine of prince.

He reseruyde undir derknesse aungelis that kepten not her *prynshood*, but forsoken their hous into the doom of the gret God, into euerlastinge boondis.

Wicliff. *Judas i.*

A *prince* of great courage and beauty, but fostered up in blood by his haughty father. *Sidney.*

Meaning only to do honour to their *princely* birth, they flew among them all. *Id.*

Next Archigald, who, for his proud disdain, Deposed was from *princedom* sovereign. *Spenser.*

Heaven forbid that such a scratch should drive The *prince* of Wales from such a field as this.

*Shakspeare.*

Nature prompts them,  
 In simple and low things, to *prince* it, much  
 Beyond the trick of others. *Id. Cymbeline.*

Here the bracelet of the truest *princess*  
 That ever swore her faith. *Id.*

The wrongs he did me were nothing *princelike*.  
*Shakspeare.*

Be opposite all planets of good luck  
 To my proceeding; if with pure heart's love  
 I tender not thy beauteous *princely* daughter. *Id.*

Queen Elizabeth, a *prince* admirable above her sex for her princely virtues. *Camden.*

Many townes of *princely* youths he leveled with the ground. *Chapman.*

To use the words of the *prince* of learning hereupon, only in shallow and small boats they glide over the face of the Virgilian sea. *Peucham.*

Cœlestial! whether among the thrones, or named Of them the highest; for such of shape may seem *Prince* above *princes*. *Milton's Paradise Lost.*

Under thee, as head supreme,  
 Thrones, *princedom*s, powers, dominions, I reduce. *Milton.*

*Princely* counsel in his face yet shone. *Id.*

I expressed her commands  
 To mighty lords and *princely* dames. *Waller*  
 Forces come to be used by good *princes*, only upon  
 necessity of providing for their defence. *Temple.*

Ask why God's anointed he reviled;  
 A king and *princess* dead. *Dryden.*

Esau founded a distinct people and government,  
 and was himself a distinct *prince* over them. *Locke.*  
 Had we no histories of the Roman emperors, but  
 on their money, we should take them for most virtuous  
*princes*. *Addison.*

God put it into the heart of one of our *princes*,  
 towards the close of her reign, to give a check to that  
 sacrilege. *Atterbury.*

*Princess* adored and loved, if verse can give  
 A deathless name, thine shall for ever live. *Granville.*

Our tottering state still distracted stands,  
 While that *prince* threatens, and while this com-  
 mands. *Pope.*

Under so excellent a *princess* as the present queen,  
 we suppose a family strictly regulated. *Swift.*

Happy those *princes*, who are educated by men  
 who are at once virtuous and wise, and have been  
 for some time in the school of affliction; who weigh  
 happiness against glory, and teach their royal pupils  
 the real value of fame. *Goldsmith.*

PRINCE also denotes a person who is a sove-  
 reign in his own territories, yet holds of some  
 other as his superior. Also the issue of princes, or  
 those of any royal family. In England the king's  
 children are called sons and daughters of Eng-  
 land; the eldest son is created prince of Wales;  
 the cadets are created dukes or earls as the king  
 pleases; and the title of all the children is royal  
 highness; all subjects are to kneel when ad-  
 mitted to kiss their hand, and at table out of  
 the king's presence they are to be served on the  
 knee. See ROYAL FAMILY.

PRINCE FREDERICK'S SOUND, an inlet of the  
 North Pacific Ocean, on the west coast of North  
 America; so named by Vancouver in honor of  
 the late duke of York. Long. 225° 42' to 227°  
 20', lat. 56° 52' to 57° 12' N.

PRINCE OF THE SENATE, in ancient Rome,  
 the person who was called over first in the roll  
 of senators, whenever it was renewed by the  
 censors: he was always of consular and censo-  
 rian dignity.

PRINCE OF WALES'S ARCHIPELAGO, a large  
 island of the North Pacific Ocean, surrounded  
 by a number of smaller ones, chiefly in the bays  
 on its coast. They lie in long. 226° 20' to 228°  
 26', and lat. 54° 42' to 56° 21' N., and were so  
 called by Vancouver.

PRINCE OF WALES'S, PULO PINANG, or BE-  
 TEL NUT, ISLAND, an island off the west coast  
 of the Malay peninsula, from which it is sepa-  
 rated by a narrow strait, about two miles broad,  
 which forms the harbour, and affords excellent  
 anchorage for the largest ships. There is also  
 an inner harbour, where ships may receive all  
 repairs that can be performed without going  
 into dock. The principal entrance into the  
 harbour is from the north-west; but there is  
 also a fine channel to the southward. Here is  
 always at least four fathoms, or four fathoms and

a half of water, but it deepens within to fourteen fathoms. The south channel is obstructed by mud banks, but which are buoyed, and leave a safe channel with three fathoms and a half.

The island is five leagues long, and two to three broad. On the north-west it rises in high hills, covered with large trees; on the east side is an extent of level ground well-cultivated. The island has two rivers considerable for its size. That called Paz winds through the level part of the island for twenty miles; its mouth is crossed by a mud bank with twelve feet in the springs, but boats can ascend it a considerable way. The second river, called Taloo Moodoo, is a rapid torrent stream that often overflows; its mouth is crossed by a sand bank.

Fort Cornwallis is situated on the north-east point of the island, and, though considerable sums have been expended on it, is little more than a sufficient defence against the Malays, and is incapable of any resistance to a regular attack by European tactics. The town, named George Town by the English, and Panjang Panaique by the Malays, is of considerable extent; the streets wide and straight, with many good houses. A river runs close past it, and it has a good wharf for loaded boats, to which water is conveyed by pipes. A government house, a jail, a church, and several bridges have been latterly built, and other improvements executed.

Pulo Pinang was granted by the king of Quada, 1787, to captain Light, who married his daughter, and who transferred it to the East India Company. Its situation rendering it an eligible rendezvous for the British China trade, as well as a retreat for the king's ships when obliged to quit the Coromandel coast in the monsoon, a small detachment of troops was sent from Bengal to occupy it; and several English merchants, engaged in the Malay trade, making it their depot, it rapidly increased in population, particularly by the arrival of Chinese and Malays. In 1805 it was erected into a separate government, and a large establishment appointed to it. In 1801 the population was 16,000, exclusive of Europeans and military; of those 2000 are Chinese, who chiefly follow the mechanical trades and shopkeeping, while the Malays, who constitute the mass of the remaining population, cultivate the soil, and chiefly pepper, rice, areca, and cocoa palms.

Though situated within five degrees of the equator, the climate of Prince of Wales's Island is remarkably temperate: the sea breeze that blows regularly throughout the day moderates the heat, and the vapors collected by the woody mountains condense in the night in heavy dews, that perpetuate a verdant herbage, unknown in southern India. One of the mountains rises with a steep ascent to a considerable elevation, and on its summit, which forms a platform of forty yards in diameter, is a signal-house. The thermometer at this elevation seldom rises above 75°, and in the night falls to 60°. At the town the extremes are 85° and 75°. Among several waterfalls which this beautiful island possesses, one in particular attracts the notice of travellers, by its wildly picturesque effect: it precipitates itself down a rocky precipice

Vol. XVIII.

into a natural basin, surrounded by perpendicular walls of rock, whose craggy projections are covered with lofty trees and evergreen shrubs, and forming a fit retreat for Diana and her nymphs, or for Thomson's more interesting Musidora,

To taste the lucid coolness of the flood.

Pinang has no beasts of prey, nor any wild quadrupeds but wild hogs, the little animal named hog-deer, and the bandicoot, a species of rat. Alligators are very numerous, and the termites, or white ants, are here peculiarly destructive. Pinang is abundantly supplied with poultry from the opposite coast, whence are also brought buffaloes for draft, and horses are procured from Sumatra. The sheep for the tables of the English come from Bengal. Fruits are in extreme plenty, particularly pine-apples, which grow wild, shaddocks, oranges, limes, &c.

The harbour abounds in fish, principally of the flat kind. The rocks are covered with a delicate small oyster, and on the banks, before the entrance of the rivers, common oysters are found. In short there is nothing wanting to render this island the most pleasant residence in India. A building-yard has been established at Pinang, and a ship of war and Indiaman of 1000 tons have been built here, the principal part of the timber being brought from Peru. The rise of tide is nine feet. The value of the goods imported hither in 1807 from England amounted to £76,000; in 1810 to £38,253. Large quantities of Bengal and Madras piece-goods are imported for the Malay trade, and the consumption of European residents. Other imports are opium, grain, tobacco, red wood, sandal-wood, shark-fins, myrrh, pepper, rice, betel-nut, benzoin, camphor, gold dust, elephants' teeth, &c. A great many of these commodities are re-exported to Sumatra, Junk Ceylon, and the other Indian islands; also to China, to Bengal, and Coromandel. Long. of the north-east point 100° 19' E., lat. 5° 25' N.

PRINCE'S ISLAND, a low woody island in the Eastern Seas, off the north-western extremity of Java, at the distance of about two leagues, and six from Sumatra. On the south-west side is a bay, into which two small fresh-water rivulets flow. There has of late been a town erected here, called Samadang, consisting of about 400 houses, and this island was formerly much frequented by the Indian ships of many nations. Here may be had some excellent turtle and fowls, and deer, besides all the usual vegetable productions of the neighbourhood. Long 105° 15' E., lat. 6° 25' S.

PRINCE'S ISLAND, an island in the gulf of Benin, and Bight of Biafara, about 100 miles off the coast of West Africa. It is ninety miles in circumference, and is fertile in rice, tobacco, millet, manioc, sugar-canes, and fruits. It was discovered and settled by the Portuguese in 1471. On the north coast there is a town with a good harbour, containing about 200 houses. Long. 7° 10' E., lat. 1° 50' N.

PRINCE'S ISLANDS, four small islands inhabited by the Greeks, in the sea of Marmora, near the straits of Constantinople, being only

about twenty miles from that capital, called Prinkipo, Prote, Kalke, and Antigone. They are situated near the entrance of the gulf of Nicomedia, and are frequently resorted to from Constantinople.

PRINCE WILLIAM HENRY'S ISLAND, an island in the East Indian Ocean, W. N. W. of Tench's Island, about seventy miles in circumference; discovered by Ball and Philip in 1790. It is fertile, and inhabited by naked savages, who, however, have houses, canoes, &c. There is a high mountain in the centre, called St. Philip. Long. 149° 30' E., lat. 1° 32' S.

PRINCE WILLIAM HENRY'S ISLAND, an island in the South Pacific Ocean, discovered in 1767, by Captain Wallis.

PRINCE WILLIAM'S SOUND, a name given by captain Cook, in 1778, to an inlet of the sea on the north-west coast of America; which occupies at least two degrees of longitude and one and a half of latitude, exclusive of its arms and branches, the extent of which is unknown.

From this sound or bay the name has been extended to a considerable territory on the coast. The men, women, and children, are all clothed in a sort of close frock, or robe, which sometimes reaches only to the knees, but generally down to the ancles. These frocks are composed of the skins of various animals, and commonly worn with the hairy side outwards. The men often paint their faces of a black color, and of a bright red, and sometimes of a bluish or leaden hue; but not in any regular figure. The women puncture and stain the chin with black, that comes to a point in each cheek. Their canoes are of two sorts; the one large and open, the other small and covered. The framing consists of slender pieces of wood, and the outside is composed of the skins of seals, or sea animals, stretched over the wood. Their weapons, and implements for hunting and fishing, are the same as those used by the Greenlanders and Esquimaux. Many of their spears are headed with iron, and their arrows are generally pointed with bone. The food they were seen to eat was the flesh of some animal, either roasted or broiled, and dried fish. Some of the former that was purchased had the appearance of bear's flesh. They also eat a larger sort of fern-root, either baked, or dressed in some other method. Their drink is water; in their canoes, they brought snow in wooden vessels, which they swallowed by mouthfuls. The skins, that were brought by the natives for sale, were principally of bears, common and pine martins, sea otters, seals, racoons, ermines, foxes, and whitish cats or lynxes. The birds were the halcyon, or great king's fisher, which had fine bright colors; the white headed eagle, and the humming bird. The fish brought to market for sale were chiefly torsk and halibut. The rocks were almost destitute of shell-fish; and the only other animal of this tribe that was observed was a reddish crab, covered with very large spines. Few vegetables of any kind were observed; and the trees that chiefly grew about this sound were the Canadian spruce pine, some of which were of a considerable size. Vancouver visited this sound in 1794, and says 'after a minute examination we were empowered to

make of Prince William's Sound, we were not only made acquainted with its utmost limits in every direction, but proved it to be a branch of the ocean that requires the greatest circumspection to navigate; and, although it diverges into many extensive arms, yet none of them can be considered as commodious harbours, on account of the rocks and shoals that obstruct the approach to them, or of the very great depth of water at or about their entrances: of the former, innumerable have been discovered, and there is great reason to suppose that many others may have existence, of which we gained no knowledge. By what may be collected from our enquiries, Snug-corner Cove, and the passage to it from the ocean, seem to be the least liable to these objections of all places of shelter which the sound affords.' Long. 147° W., lat. 20° to 61° N.

PRINCESS ROYAL ISLANDS, a considerable group of islands on the western coast of North America, east of Queen Charlotte's Islands, between Pitt's Archipelago and Fitzhugh's Sound. They were first visited by Mr. Duncan who found a navigable channel between them, and afterwards more fully explored by Vancouver.

PRINCIPAL, *adj.* & *n. s.* } Fr. *principal* ;  
PRINCIPALITY, } Lat. *principalis*.  
PRINCIPALLY, *adv.* } Chief; princely ;  
first; important: a head or chief; one primarily engaged; a capital sum of money: principality is sovereignty; superiority; one invested with sovereignty or great power; predominance; the country giving title to a prince: principally, chiefly; above the rest; above all the rest.

I am certeyn that neither death, neither lyf, neither aungelis, neither *principalis*, neither vertues — mai departe us from the charite of God that is in Iesu Crist oure Lord. *Wiclif. Rom. 8.*

Divine lady, who have wrought such miracles in me, as to make a prince none of the basest, to think all *principalities* base in respect of the sheep-hook.

*Sidney.*

Suspicion of friend, nor fear of foe,  
That hazarded his health, had he at all;  
But walked at will, and wandered to and fro,  
In the pride of his freedom *principal*. *Spenser.*

Nothing was given to Henry but the name of king; all other absolute power of *principality* he had. *Id.*

This latter is ordered, partly and as touching *principal* matters by none but precepts divine only; partly and as concerning things of an inferior regard by ordinances, as well human as divine. *Hooker.*

Can you remember any of the *principal* evils that he laid to the charge of women? *Shakespeare.*

Thou wilt not only lose the forfeiture,  
But, touched with human gentleness and love,  
Forgive a moiety of the *principal*. *Id.*

Yet let her be a *principality*,  
Sovereign to all the creatures on the earth. *Id.*  
Seconds in factions, do many times, when the faction subdivideth, prove *principals*. *Bacon.*

In the chief work of elements, water hath the *principality* and excess over earth.

*Digby on Bodies.*

Nisroch of *principalities* the prime. *Mittur.*

PRINCETON; a post-town of New Jersey, 10 miles north of Trenton, 40 north-east of Philadelphia, and 49 south-west of New York; lat. 40° 22' N.; lon. 74° 35' W. It is a pleasant town, and contains a college, a theological semi-

nary, a brick Presbyterian church, and more than 100 houses. The college of New Jersey was founded in 1746, at Elizabethtown; the next year it was removed to Newark, and a royal charter was granted to it in 1748, by its present title. It remained at Newark ten years, and was permanently established at Princeton in 1757. Its situation is peculiarly healthful and pleasant, and it has long been a highly respectable and flourishing seminary. The college edifice is styled Nassau Hall, and is one of the most prosperous literary establishments in North America. Princeton was distinguished during the revolution by a decisive battle between the British troops and a detachment of the American army under General Washington. The British lost 100 killed, and 300 prisoners, who had taken refuge in the college: One of the American generals fell in this action.

**PRINCIPAL**, in English law, is either the actor or absolute perpetrator of the crime, who is called a principal, in the first degree; or he who is present, aiding and abetting the fact to be done, who is denominated a principal in the second degree. The presence of a principal need not always be an actual immediate standing by, within sight or hearing of the fact; but there may be also a constructive presence, as when one commits a robbery or murder, and another keeps watch or guard at some convenient distance. In case of murder, by poisoning, a man may be a principal felon by preparing and laying the poison, or giving it to another (who is ignorant of its poisonous quality) for that purpose, and yet not administer it himself, nor be present when the very deed of poisoning is committed. The same reasoning holds, with regard to other murders committed in the absence of the murderer, by means prepared before-hand, and which could hardly fail of their mischievous effect. As by laying a trap or pit-fall for another, whereby he is killed; letting out a wild beast, with an intent to do mischief; or exciting a madman to commit murder; in every one of these cases the party offending is guilty of murder as a principal, in the first degree. For he cannot be called an accessory, that necessarily pre-supposing a principal; and the poison, the pit-fall, the beast, or the madman, cannot be held principals, being only the instruments of death. He must therefore be held certainly guilty in the first degree.

**PRINCIPATO CITRA**, or **CITERIORE**, a province in the central part of Naples, on the Mediterranean. It is of an irregular form, about ninety miles in length from north-west to south-east, and forty-five at its greatest breadth. Its territorial extent is 2400 square miles; for the most part mountainous, but traversed by a plain, extending from Salerno to Agropoli, and watered by the rivers Silaro, Sarno, Calore, and Negro. The mountains are in general well wooded, and a number of them covered with chestnut-trees. The plains are rich in corn and rice; but the too extended cultivation of the latter has in several places made the climate unhealthy. The other products are wine, olive-oil, and fruit. Hogs are reared in great numbers; and on the coast are considerable fisheries. The principal exports are chestnuts, timber, rice, dried fruit,

particularly figs; wine, hides, and pork. The capital is Salerno. Population about 245,000.

**PRINCIPATO ULTRA**, or **ULTERIORE**, a province of the kingdom of Naples, south of the above, with a superficial extent of 1800 square miles, and traversed by the Apennines. It consists of an intermixture of mountains and well-cultivated valleys, and is watered by the Sabato, Tammaro, Calore, and Ofanto. Its climate is pure and salubrious, and the products are corn, wine, fruit, chestnuts, olive oil, and timber for export. The breeding of cattle and sheep is carried on extensively in the mountainous parts; in warmer situations silk worms are reared. The only exports consist of raw products. The chief town is Avellino. Population 358,000.

**PRINCIPIATION**, *n. s.* Lat. *principium*. Analysis into constituent or elemental parts. A word not received.

The separating of any metal into its original or element, we will call *principiation*. *Bac.n.*

**PRINCIPLE**, *n. s. & v. a.* Fr. *principe*; Lat. *principium*. Element; constituent part; primordial substance, or cause; fundamental truth; motive: to fix in any tenet or principle.

Touching the law of reason, there are in it some things which stand as *principles* universally agreed upon; and out of those *principles*, which are in themselves evident, the greatest moral duties we owe towards God or man, may, without any great difficulty, be concluded. *Honker.*

Farewel, young lords; these warlike *principles* Do not throw from you. *Shakspeare.*

Such kind of notions as are general to mankind, and not confined to any particular sect, or nation, or time, are usually styled common notions, seminal *principles*; and *lex nata*, by the Roman orator.

*Wilkins.*  
Wisest and best men full oft beguiled,  
With goodness *principled* not to reject  
The penitent, but ever to forgive,  
Are drawn to wear out miserable days. *Milton.*

The soul of man is an active *principle*, and will be employed one way or other. *Tillotson.*

Some few, whose lamp shone brighter, have been led,  
From cause to cause to nature's secret head,  
And found that one first *principle* must be. *Dryden.*

Governors should be well *principled* and good-natured. *L. Estrange.*

Let an enthusiast be *principled*, that he or his teacher is inspired, and you in vain bring the evidence of clear reasons against his doctrine. *Lock.*

The promiscuous reading of the bible is far from being of any advantage to children, either for the perfecting their reading, or *principing* their religion. *Id.*

For the performance of this, a vital or directive *principle* seemeth to be assistant to the corporeal. *Grew's Cosmologia.*

It is the concern of his majesty, and the peace of his government, that the youth be *principled* with a thorough persuasion of the justness of the old king's cause. *South.*

There are so many young persons, upon the well and ill *principing* of whom next under God, depends the happiness or misery of this church and state. *Id.*

I'll try

If yet I can pursue those stubborn *principles*  
Of faith, of honour. *Addison's Cato.*

Plato lays it down as a *principle*, that whatever is permitted to befall a just man, whether poverty or sickness, shall, either in life or death, conduce to his good. *Addison.*

As no *principle* of vanity led me first to write it, so much less does any such motive induce me now to publish it. *Wake.*

A feather shooting from another's head,  
Extracts his brain, and *principle* is fled. *Pope.*

He seems a settled and *principled* philosopher,  
thanking fortune for the tranquillity he has by her aversion. *Id.*

All of them may be called *principles*, when compared with a thousand other judgments, which we form under the regulation of these primary propositions. *Watts's Logic.*

All kinds of dishonesty destroy our pretences to an honest *principle* of mind, so all kinds of pride destroy our pretences to a humble spirit. *Law.*

Man's obligations infinite of course,  
His life should prove that he perceives their force,  
His utmost he can render is but small,  
The *principle* and motive all in all. *Courper.*

PRIN'COCK, *n. s.* } From prink or prim-  
PRIN'cox. } cock. A coxcomb; a  
conceited person. A ludicrous word. Obsolete.

You are a saucy boy ;  
This trick may chance to scathe you I know what ;  
You must contrary me ! you are a *princor*, go. *Shakspeare.*

PRINGLE (Sir John), an eminent physician and younger son of Sir John Pringle of Roxburgh; who took the degree of M. D. at Leyden, 1730; and published there *Dissertatio Inauguralis de Marcere Senili*, 4to. After having been some years professor of moral philosophy at Edinburgh, he was, in June 1745, appointed physician to the duke of Cumberland, and physician to the hospital of the forces in Flanders, where the earl of Stair appears to have been his patron. In February 1746 Dr. Pringle, Dr. Armstrong, and Dr. Barker, were nominated physicians to the hospital for lame, maimed, and sick soldiers, behind Buckingham House; and in April 1749 Dr. Pringle was appointed physician in ordinary to the king. In 1750 and 1755 he published *Observations on the Nature and Cure of Hospital and Gaol Fevers*, in a Letter to Dr. Mead, 8vo.; and in 1752 *Obser-*

vations on the Disorders of the Army in Camp and Garrison, 8vo. On the 14th of April, 1752, he married Charlotte, daughter of Dr. Oliver, an eminent physician at Bath. In 1756 he was appointed, jointly with Dr. Winttingham, physician to his majesty's hospital for the forces of Great Britain. After the accession of king George III. Dr. Pringle was appointed physician to the queen's household in 1761; physician in ordinary to the queen in 1763, when he was admitted of the College of Physicians in London; and, on the 5th of June 1766, he was created a baronet of Great Britain. In 1772 he was elected president of the Royal Society, where his speeches for five successive years, on delivering the prize medal of Sir Godfrey Copley, gave great satisfaction. In 1777 he was appointed physician extraordinary to the king. He was also a fellow of the College of Physicians at Edinburgh, and of the Royal Medical Society at Paris; member of the Royal Academies at Paris, Stockholm, Gottingen, and of the Philosophical Societies at Edinburgh and Haerlem; and continued president of the Royal Society till November 1778; after which period he gradually withdrew from public life. He died January 18th, 1782.

PRINK, *v. n.* Belg. *pronken*. To prank; deck for show. The diminutive of prank.

Hold a good wager she was every day longer *prinking* in the glass than you was. *Art of Tormenting.*

PRINKIPO, the most eastern and considerable of the Prince's Islands, in the bay of Marmora, about a league distant from the coast of Asia Minor. It is about a mile in length, and half a mile in breadth, containing a town, now in a ruinous condition. The French merchants used formerly to have country houses on this island, but they have abandoned them, on account of the badness of the water, and other inconveniences; it is at present inhabited only by a few Greeks, who support themselves by selling wine and provisions to the pleasure parties which come from Constantinople. Long. 28° 56' E., lat. 40° 51' N.

PRINOS, winter berry, a genus of the monogynia order, and hexandria class of plants; natural order forty-third, *dumosæ*: *CAL. sexfid*: *cor.* monopetalous, and rotaceous; the belly exaspermous. Species ten, all native shrubs of North America and the West Indies.

## P R I N T I N G.

PRINT, *v. a.*, *v. n.* & *n. s.* } Fr. *empreint* ;  
PRINTER, *n. s.* } Ital. *imprenta* ;  
PRINTING, } Belg. *printe*. To  
PRINTLESS, *adj.* } indent or mark  
by pressure; impress a thing so as to leave its form; to form by impression; impress the form of type, &c., on paper, so as to make a book; the term is likewise applied to taking off copper-plates by a press, and the figures of blocks, &c., used in calico, silk, and other printing: as a neuter verb, to use the typographic art; publish a book: a print is a mark or form impressed; a feature made by impression; the form, ar-

rangement or size, of printing types; mould or pattern cut in wood, copper, &c.; single sheet, printed for sale; a newspaper: a printer is, 'par excellence,' one who prints books; but also applied to similar operators on linen, calico, silk, &c.: printing, the art or business of a printer: printless, that which leaves no impression.

Ye shall not make any cuttings in your flesh for the dead, nor print any marks upon you. *Leviticus.*

Oh, that my words were now written ! Oh, that they were printed in a book. *Job xix. 23.*

My soul is but a wind,  
Which passeth by, and leaves no print behind. *Sandy.*

Your mother was most true to wedlock, prince,  
For she did *print* your royal father off,  
Conceiving you. *Shakspeare. Winter's Tale.*  
Thou hast caused *printing* to be used; and, con-  
trary to the king, his crown, and dignity, built a  
paper-mill. *Shakspeare.*

Attend the foot,  
That leaves the *print* of blood where'er it walks. *Id.*

I love a *ballad in print*, or a life. *Id.*  
Ye elves,

And ye, that on the sands with *printless* foot  
Do chase the ebbing Neptune. *Id. Tempest.*  
Our life so fast away doth slide,  
As doth an hungry eagle through the wind;  
Or as a ship transported with the tide,  
Which in their passage leave no *print* behind. *Davies.*

Up they tost the sand,  
No wheel seen, nor wheels *print* was in the mould  
imprest  
Behind him. *Chapman's Iliad.*

It is so rare to see  
Ought that belongs to young nobility  
In *print*, that we must praise. *Suckling.*  
I find, at reading all over, to deliver to the  
*printer*, in that which I ought to have done to  
comply with my design, I am fallen very short. *Digby.*

While the heaven, by the sun's team untrod,  
Hath took no *print* of the approaching light,  
And all the spangled host keep watch. *Milton.*

Whilst from off the waters fleet,  
Thus I set my *printless* feet,  
O'er the cowslip's velvet head,  
That bends not as I tread. *Id.*

Perhaps some footsteps *printed* in the clay,  
Will to my love direct your wand'ring way. *Rose.*  
From my breast I cannot tear  
The passion, which from thence did grow;  
Nor yet out of my fancy raze  
The *print* of that supposed face. *Waller.*

On his fiery steed betimes he rode,  
I hat scarcely *prints* the turf on which he trod. *Dryden.*

Winds, bear me to some barren island,  
Where *print* of human feet was never seen. *Id.*  
The *prints*, which we see of antiquities, may con-  
tribute to form our genius, and to give us great ideas. *Id.*

To refresh the former hint;  
She read her maker in a fairer *print*. *Id.*  
Is it probable that a promiscuous jumble of  
*printing* letter should often fall into a method,  
which should stamp on paper a coherent discourse? *Locke.*

As soon as he begins to spell, pictures of animals  
should be got him, with the *printed* names to them. *Id.*

If they be not sometimes renewed by repeated  
exercise of the senses or reflection, the *print* wears  
out. *Id.*

Before the lion's den appeared the footsteps of  
many that had gone in, but no *prints* of any that  
ever came out. *South.*

His natural antipathy to a man who endeavours  
to signalize his parts in the world, has hindered  
many persons from making their appearance in *print*. *Addison.*

The *prints*, about three days after, were filled with  
the same terms. *Id.*  
I published some tables, which were out of *print*. *Arbutnot.*

Inform us, will the emperor treat,  
Or do the *prints* and papers lie? *Pope.*

This nonsense got in by a mistake of the stage  
editors, who *printed* from the piecemeal written parts. *Pope.*

To buy books, only because they were published  
by an eminent *printer*, is much as if a man should  
buy clothes that did not fit him, only because made  
by some famous taylor. *Id.*

See, the *printer's* boy below;  
Ye hawkers all, your voices lift. *Swift.*

He was sent without any superintendent to con-  
duct a *printing-house* at Norwich, and publish a  
weekly paper. *Johnson.*

Satires and lampoons on particular people cir-  
culate more by giving copies in confidence to the friends  
of the parties, than by *printing* them. *Sheridan.*

PRINTING, the art of taking impressions from  
characters or figures, moveable and immovable,  
on paper, linen, silk, &c. There are three kinds  
of printing; the one from moveable letters for  
books; another from copper-plates for pictures;  
and the last from blocks, in which the represen-  
tation of birds, flowers, &c., are cut for printing  
calicoes, linen, &c. The first is called common  
or letter-press printing; the second rolling-press  
printing; and the last calico, &c., printing. The  
principal difference between the three consists in  
this, that the first is cast in relievio, in distinct  
pieces; the second engraven in creux; and the  
third cut in relievio, and generally stamped, by  
placing the block upon the materials to be  
printed, and striking upon the back of it.

Of the above branches, letter-press printing is  
the most curious, and deserves the most particu-  
lar notice; for to it are owing chiefly our deli-  
verance from ignorance and error, the progress  
of learning, the revival of the sciences, and  
numberless improvements in arts, which, without  
this noble invention, would have been either lost  
to mankind, or confined to the knowledge of a  
few.

HISTORY.—It has been a matter of considera-  
ble surprise that some method of printing was  
not invented at a much earlier epoch in the his-  
tory of the world. The arts of statuary and  
sculpture arrived at very great perfection among  
the Romans; the cutting of their seals and dies  
may be considered as a kind of printing on  
metals; and their impressing these seals, cut in  
cornelians, agates, &c., on wax, was another  
species of printing on this substance. This was  
the very germ of the art; and it is perfectly as-  
tonishing that no should have thought of printing  
two words together as well as one; and they  
have multiplied them into a page. They set  
their foot on the very pearl, without stopping to  
notice or pick it up.

The origin of printing is completely enveloped  
in mystery; and an art which commemorates  
all other inventions—which hands down to pos-  
terity every important event—which immortalises  
the discoveries of genius and the exploits of  
greatness—which has been the only effectual in-  
strument that could banish the darkness, and  
overturn the superstitions of a bigoted age; and  
which, above all, extends and diffuses the word  
of God to all mankind; this very art has left its  
own origin in obscurity, and has given employ-  
ment to the studies and researches of the most  
learned men in Europe to determine to whom  
the honor of its invention is justly due.



The art of printing combines such a number and variety of branches that it would be absurd to suppose any one person could have invented the whole. In its present state of perfection, it is divided into eight or ten different kinds of manufactures; and even in its rudest state must have required such an extensive acquaintance with mechanics, chemistry, and other branches of science, as could not be supposed to fall to the lot of any one or two men. It is this circumstance, doubtless, which has given plausibility to the claims of the numerous persons handed down to us as the original inventors of the art. The simple idea may have originated with a single individual, but a second person may have made such an important improvement as almost to eclipse the value of what his predecessor had accomplished. A third person may be supposed to have rendered a still greater addition to the art, and, either in reality or in idea, to attract to himself the merit of the whole: and indeed these appear to be the real merits of the case, and the only possible mode of reconciling the diversified and clashing statements which have been promulgated. The taking impressions from pages cut on blocks of wood, and from separate metal types cast for the purpose, are operations so entirely different, and the one is an art so decidedly inferior to the other, that they ought never to have been confounded under the same name: in the sequel we shall find that the merit of the two is not confined either to one person, or the honor to one place.

The honor of this invention has been appropriated to several places; to Mentz, to Strasburg, to Harlem, to Dordrecht, to Venice, to Rome, to Florence, to Basle, to Augsburg, &c. Three only of these places, however, deserve any serious consideration: viz. Harlem, Mentz, and Strasburg. At the last mentioned place many attempts appear to have been made towards the discovery and completion of the art by John Gutenberg; but, as there is no evidence that he actually brought his experiments to bear in the publication of any work at Strasburg, nothing more need be said of this city, though we shall have frequent occasion to introduce the name of this ingenious artist.

The most consistent account of the origin of the art of printing is that which is given by Hadrian Junius, and which favors the claims of Laurence Coster, of the city of Harlem. This account is contained in his *Batavia*, published after his death at Leyden, more than a century after the supposed invention of the art, and is the only paper or testimony upon which the partisans of the city of Harlem found their typographical pretensions. Junius had the relation from two respectable men, Nicholas Galius, his intimate friend and correspondent and the pupil of Galius, Quirinius Talesius, both of whom had informed him, that they had in their youth heard this same story related more than once, by a certain bookbinder, nearly eighty years of age, named Cornelius, who professed to have been one of Coster's domestics. The substance of the narration of Junius is as follows:—'It is now about 128 years,' he says, 'since Laurence, the son of John, a citizen of Harlem, and surnamed

Coster (that is, sacristan or church-warden, at that time an honorable office, and which his family had long held by hereditary right), amused himself, during his walks in the wood near that city, with forming letters of the bark of the beech tree, by means of which he printed upon paper some verses and short sentences, for the instruction of his grand-children. With the assistance of his son-in-law Thomas, the son of Peter, he afterwards invented an ink, more viscous and tenacious than common ink, which was found to blot and fill the letters; with this new ink he printed, in the Flemish language, the *Speculum nostræ Sæculis*, a work composed of images and letters. The leaves of this book being printed on one side only, the pages, which were left blank, were afterwards pasted together. After this, Coster abandoned the use of wooden letters, and adopted metal ones; forming them at first of lead, and latterly of tin, which metal is rather harder than the former: some metal wine cups, made from the remains of these letters, may yet be seen in the dwelling-house of his descendants. The great profits which the inventor derived from this new art induced him to increase his establishment, and with this view he took some workmen into his family. One of these, who was called John, surnamed Fust, as is suspected, or some other person bearing the name of John (it is of no great consequence which), after having learnt the art of arranging and casting types, as well as all other matters relating to the art of printing, in the knowledge of which he had been initiated under the obligation of an oath, seized the opportunity of his master being engaged at mass, on the night of Christmas eve, to carry off all the types and implements used in the printing office. He went with his plunder to Amsterdam, in the first instance, then to Cologne, and finally settled at Mentz, where he established a printing office, in which were printed, in the year 1442, with the types stolen from Harlem, the *Doctrinalè Alexandri Galli*, and the *Tractatus Petri Hispani*.'

The narrative of Junius has been questioned, and indeed violently opposed, by writers of the first literary eminence: and it certainly appears a remarkable circumstance that no Dutch writer, nor any work of the fifteenth or of the beginning of the sixteenth century, has made the least mention of these facts—not even Erasmus, who, from having been born at Rotterdam in the year 1467, could hardly have been ignorant of events at once so singular and so creditable to his native country. There are several other objections to the above narrative, which we cannot here notice: but, without relying implicitly on all the statements of this narrative, it seems to us pretty evident that Coster carried the art of printing from impressions cut upon blocks to a greater extent, and applied it to a greater variety of purposes, than any person in Europe who had preceded him: though the merit of even this part of the art is not wholly due to himself; it had been practised in many countries for centuries, and especially in China, where it continues to the present day, with scarcely any variation or improvement.

It may be advisable to divide the history of the art into four parts:—the first embracing the

mode of striking impressions from signets, seals, and other emblems cut on wood, or other substances, the origin of which is totally lost. The second stage is that which introduces us to the name and labors of Laurence Coster, who applied block printing to the production of books, of which his *Speculum humanæ Salvationis* is said to be the first instance. This work consists of pictures out of the Bible, with some of the verses underneath each page, the whole being printed from a block of wood, like a wood-cut. He seems also to have had the merit of printing from separate wooden letters, cut so as to fit each other when composed together, and perhaps with the small words of most frequent use cut upon one block, to save the time and labor of the compositor. This occurred between the years 1431 and 1443. The third stage of the art was the adoption of cut metal instead of wooden letters, which is doubtless to be traced to the labors of John Geinsflesh, jun., distinguished by the name of Guttenberg. This person, with the assistance of his father, Geinsflesh the elder, invented cut metal types, and used them in printing the earliest edition of the Bible. This edition appeared in 1450, and the completing of it took up seven or eight years. The fourth and last stage of the art, and which brought it to almost as high a state of perfection as it attained for two centuries afterwards, was the mode of casting types in matrices, which was invented by a servant of Guttenberg's, of the name of Peter Schoeffer. For this valuable service he was admitted into the family of his master, Fust or Faustus, and was rewarded with the hand of one of his daughters. The first work printed on these improved types was the *Durandi Rationale*, in 1459. Most persons are acquainted with the legend of the Devil and Dr. Faustus. The origin of the tale is, that Faust carrying a parcel of his bibles to Paris, and offering them for sale as MSS., the French, upon considering the number of books, and their exact conformity with each other, even to a point, concluded that there was witchcraft in the case, and, it is said, that by either actually indicting him as a conjuror, or threatening to do so, they extorted the secret. This perhaps, however, is but a new editor of a fabulous tale; as a Dr. Faustus who had correspondence with his Satanic majesty lived at a much earlier period.

In the year 1462 the city of Mentz, where Faust had settled, was taken and plundered; and the art of printing, in the general ruin, was made public, and quickly spread itself over a great part of Europe. Harlem and Strasburg practised it very early; and whence it appears to have proceeded to Rome, to Paris, to Constantinople, and to most of the principal towns on the continent.

The date and mode of its introduction into England is a subject involved almost in as much mystery as the original invention of the art. It was an opinion regularly delivered down by our historians, that the art of printing was introduced and first practised in England by William Caxton, a mercer and citizen of London, who by his travels abroad, and a residence of many years in Holland, Flanders, and Germany, in the affairs of trade, had an opportunity of informing

himself of the whole method and progress of the art, and by the encouragement of the great, and particularly of the abbot of Westminster, first set up a press in that abbey, and began to print books soon after the year 1471. This was the tradition of our writers, till a printed book or chronicle, which had scarcely been observed by the curious, was discovered, as it is said, in the archbishop of Canterbury's Palace, with a date of its impression from Oxford, anno 1468; and was considered immediately as a clear proof and monument of the exercise of printing in that university, several years before Caxton returned from the continent.

The discovery of this book seemed at once to deprive Caxton of the glory he had long enjoyed—as the author of printing in this kingdom. Its authenticity, however, has been warmly disputed by Mr. Palmer, in his *History of Printing*; by Dr. Ducarvel, in his *Letters to Meerman*; and especially by Dr. Conyers Middleton, who maintains that there was no printing in England till the introduction of it by Caxton. Indeed, if the fact were as stated by the alleged Chronicle in the archbishop's palace, it would derogate but little from the honor of Caxton, who was certainly the first person in England who practised the art of printing with fusile types, and consequently the first who brought it to perfection: whereas Corsellis, the other claimant, printed from separate cut types in wood, that being the only method he had learnt at Harlem. Great opposition was frequently manifested by magistrates and others, when this useful art was first introduced into a new city or town. We are told, in an old pamphlet in the collection of the earl of Orford, that, when it was introduced into Norwich, a general petition was presented to the magistracy against this unnecessary innovation.

Caxton had been bred very reputably in the way of trade, and served an apprenticeship to one Robert Large a mercer; who, after having been sheriff and lord mayor of London, died in the year 1441. From the time of his master's death he spent the following thirty years beyond sea in the business of merchandise. There is no clear account left of his age: but he was certainly very old, and probably above fourscore at the time of his death. In the year 1471 he complained of the infirmities of age creeping upon him, and enfeebling his body: yet he lived twenty-three years after, and pursued his business, with extraordinary diligence, in the abbey of Westminster, till the year 1494, in which he died; not in the year following as all who write of him affirm. This appears from some verses at the end of a book, called *Hilton's Scale of Perfection*, printed in the same year.

Before 1465 the uniform character was the old Gothic or German; whence our black was afterwards formed. But in that year an edition of Lactantius was printed in a kind of Semi-Gothic, of great elegance, and approaching nearly to the present Roman type; which last was first used at Rome in 1467, and soon after brought to great perfection in Italy, particularly by Jenson.

Towards the end of the fifth century, Aldus invented the Italic character which is now in use, called, from his name, *Aldine* or *curvisus*. This

sort of letter he contrived to prevent the great number of abbreviations that were then in use.

The first essays in Greek that can be discovered are a few sentences which occur in the edition of Tully's Offices, 1465, at Mentz; but these were miserably incorrect and barbarous. In the same year, 1465, was published an edition of Lactantius's Institutes, printed in monasterio Sublacensi, in the kingdom of Naples, in which the quotations from the Greek authors are printed in a very neat Greek letter. They seem to have had but a very small quantity of Greek types in the monastery; for, in the first part of the work, whenever a long sentence occurred, a blank was left, that it might be written in with a pen: after the middle of the work, however, all the Greek that occurs is printed.

In 1488, however, all former publications in this language were eclipsed by a fine edition of Homer's works at Florence, in folio, printed by Demetrius, a native of Crete. Thus printing (says Mr. Mattaire, p. 185) seems to have attained its acme of perfection, after having exhibited most beautiful specimens of Latin, Greek, and Hebrew. The earliest edition of the whole bible was, strictly speaking, the Complutensian Polygott of cardinal Ximenes; but as that edition, though finished in 1517, was not published till 1522, the Venetian Septuagint of 1518 may properly be called the first edition of the whole Greek Bible; Erasmus having published the New Testament only at Basil in 1516.

A very satisfactory account of Hebrew printing is thus given by Dr. Kennicott in his Annual Accounts of the Collation of Hebrew MSS., p. 112. 'The method which seems to have been originally observed in printing the Hebrew Bible was just what might have been expected: 1. The Pentateuch, in 1482. 2. The Prior Prophets, in 1484. 3. The Posterior Prophets, in 1486. 4. The Hagiographia, in 1487. And, after the four great parts had been thus printed separately (each with a comment), the whole text (without a comment) was printed in one volume in 1488; and the text continued to be printed, as in these first editions, so in several others for twenty or thirty years, without marginal Keri or Masora, and with greater arguments to the more ancient MSS. till about the year 1520 some of the Jews adopted later MSS. and the Masora; which absurd preference has obtained ever since.'

In 1642 a Hebrew bible was printed at Mantua under the care of the most learned Jews in Italy. This bible had not been heard of among the Christians in this country, nor perhaps in any other; though the nature of it is very extraordinary. The text indeed is nearly the same with that in other modern editions; but at the bottom of each page are various readings, amounting in the whole to above 2000, and many of them of great consequence, collected from MSS., printed editions, copies of the Talmud, and the works of the most renowned rabbies. And in one of the notes is this remark: 'That in several passages of the Hebrew bible the differences are so many and so great, that they know not which to fix upon as the true readings.'

We cannot quit this subject without observing, on Dr. Kennicott's authority, that as the first

printed bibles are more correct than the latter ones; so the variations between the first edition, printed in 1488, and the edition of Vander Hooght, in 1705, at Amsterdam, in 2 vols. Eva amount upon the whole, to above 1200!

When the art of printing was first discovered, they only made use of one side of a page; they had not yet found out the expedient of impressing the other. When their editions were intended to be curious, they omitted to print the first letter of a chapter, for which they left a blank space, that it might be painted or illuminated at the option of the purchaser. Several ancient volumes of these early times have been found, where these letters are wanting, as they neglected to have them painted.

In the productions of early printing may be distinguished the various splendid editions they made of primers or prayer books. They were embellished with cuts finished in a most elegant taste: many of them were ludicrous, and several were obscene. In one of them an angel is represented crowning the Virgin Mary, and God the Father himself assisting at the ceremony. In a book of natural history the Supreme Being is represented as reading on the seventh day, when he rested from all his works.

**PRACTICE OF THE ART.**—The workmen employed in the art of printing are of two kinds: compositors, who range and dispose the letters into words, lines, pages, &c., according to the copy delivered to them by an author; and pressmen, who apply ink upon the same and take off the impression. In London, and other large cities and towns, these two branches are usually kept so distinct that few workmen are able to engage in both of them; and in small printing-offices, where of necessity they are alternately followed, very few men are able to attain either facility or beauty in their workmanship. The process of printing is now so common, but at the same time so diversified and peculiar, that any minuteness of description would be at once incomprehensible to those who have not seen it, and quite unnecessary to those who have. In place of any detail of this kind, we shall give some information which may be valuable to persons not immediately connected with the art; and then enumerate some of those improvements which the art of printing has received within the last few years.

As it is impossible but that in every page, almost every letter of which consists of a separate piece of metal, a number of mistakes must have been made, a sheet is first printed off, which is called a proof, and given to a person employed as a corrector; who having read and marked the errors, after these are corrected, another proof-sheet is pulled, and is usually sent to the author for his revision and correction.

When the art of printing was first established it was the glory of the learned to be correctors of the press to the eminent printers. Physicians, lawyers, and bishops themselves, occupied this department. The printers then added frequently to their names those of the correctors of the press; and editions were then valued according to the abilities of the corrector. As, however authors

and editors are now so numerous a race, we shall subjoin in the margin a familiar illustration of

*The marks used in correcting a proof-sheet.*

To strike out superfluous words in a sentence a line is drawn through them; and, should it afterwards be found advisable to retain the word, dots are placed beneath, and *stet* written in the margin. An illustration is also afforded in the following line of the mode of marking those words the distance between which is to be diminished.

The men were good *stet./*

To cause words to be changed from one character to another.

From Roman type into Italic was *Ital./*  
 Italic into Roman *was rom./*  
 Roman into small capitals *was sm. Caps./*  
 Roman into large capitals *was Caps./*

To introduce the proper stops in a sentence.

The punctuation may be corrected by employing either of the annexed corrections in the margin. *⊙ ⊙ ⊙*

To transpose a word *tr* is written in the margin.

The people good were *tr*

To strike out superfluous letters or words the pen is drawn through them, and the annexed characters introduced in the margin. *S//S*

To cause a letter that is turned to be placed aright, a line is drawn through it and this character introduced in the margin. *9/*

To make two words into one.

Any thing you please. *—*

The annexed marks denote the omission of an apostrophe, and also the manner in which a letter of a different fount should be noticed, when improperly used; being the initials of the words *wrong fount*. *v w f /*

Where a word is omitted.

We went into the yesterday. *city/*

STEREOTYPE PRINTING.

Among the improvements which have been introduced into the art of printing within the last century, the first in point of time, and perhaps in point of utility, was stereotype or block printing. This is in fact something like a revival of the first essays of the art; for a complete plate is made for every page of a work, and can only be appropriated to that single page. The advantages of this are, that only a very small impression need be taken at any one time, and, as long as the plate continues, subsequent editions can be procured at a very small charge.

The honor of this invention has been claimed by the French; and so far as the mere idea goes,

without the execution, perhaps the claim may be substantiated, but no further. It is said that a Frenchman of the name of Valleyre, before the year 1735, printed the calendars at the beginning of some church books from a set of stereotype plates; but his method of proceeding was so clumsy and unprofitable as to die with the man who had invented it. The real individual to whom the honor belongs of first bringing stereotype plates into actual service was an ingenious Scotchman, of the name of William Ged, of Edinburgh. Of his proceedings and misfortunes, in attempting to carry his invention into practical effect, an account was published about fifty years ago. It appears from this narrative that in the year 1725, in consequence of a conversation he had with a printer, his attention was strongly drawn towards the practicability of forming plates from types when formed into pages. Having been furnished with a page, he instituted a series of experiments, and at last, after two years labor, he succeeded in producing impressions from his plates which could not be distinguished from those taken from types. By what method he obtained these plates it is now impossible to say, as his apparatus and the knowledge of his mode of using them was not communicated to any one at his death; indeed the tale of his sufferings and disappointments, and the selfish and dishonest hands into which it was his lot to fall, furnish the materials of an interesting and almost tragical narrative.

That part of his narrative which relates his first visit to London is possessed of sufficient interest to be placed upon durable record. Not finding any body in Scotland willing to patronise his exertions, he met with a London citizen in Edinburgh of the name of Fenner, who, while at a distance from home, could talk largely of his thousands of pounds, but who, in fact, was not worth as many shillings. With this man Ged entered into partnership, and had the deed legally signed before he left Scotland: coming, however, to London, he discovered to his sorrow that his pompous partner could scarcely give him a night's lodging. Disappointed in his expectation, he found his way into the company of Mr. Basket, the king's printer. He heard his proposals, and as Mr. Caslon the letter founder was present at the same time in the house, Mr. Basket proposed that they both should make plates from a page of type, by that day se'night, and that the overseer of the office should be the judge of the quality of each when produced. The condition of this engagement was, that the person who failed should give the other, and all the company present, a handsome dinner and entertainment at his own sole cost and charge. To the utter astonishment of Mr. Basket, the very afternoon in which Ged received the page, he obtained three separate plates with impressions from them equal to those from the original type. But alas! poor man, he made more haste than good speed; for the circumstance of his instant success reached the ear of the other competitor, and sooner than encounter a certain defeat, he evaded the bargain and made no attempt. See a History of the origin and Progress of Stereotype Printing by Mr. F. Hodgson, Newcastle.

The ingenious individual to whom is to be attributed the honor of the present mode of casting stereotype plates is Alexander Tilloch, esq., LL. D., the editor of the Philosophical Magazine, who some time prior to the year 1780, without any knowledge of Ged's invention, suggested the practicability of founding whole pages. But, as his account of his invention is very short, we will give it in his own words:—'After mentioning some of the expected advantages,' he says, 'I communicated my ideas upon this subject to Mr. Foulis, printer to the University of Glasgow, my native city, and where I then resided, who furnished me with a page of types ready set up, or composed, for my first experiment, made in 1779, which had sufficient success to induce me to try others, and convinced Mr. Foulis of the possibility of producing plates, which would yield impressions not to be distinguished from those taken from types.'

'If I had seen some of the advantages which such a plan promised, Mr. Foulis saw and pointed out many more, of such a nature as could only present themselves to a regular bred practical printer.—We agreed to prosecute the business together, and, if possible, to bring it to perfection, and in pursuance of this resolution performed, I may say, innumerable experiments, till we at last overcame every difficulty, and were able to produce plates, the impressions from which could not be distinguished from those taken from the types from which they were cast.

'In the mean time we learnt that our art, or one extremely similar, had been practised many years before by Mr. Ged, and soon after the world was favored by Mr. Nichols with an interesting pamphlet, entitled Biographical Memoirs of William Ged, including a particular account of his progress in the art of Block-Printing. Though we had reason to fear, from what we found Ged had met with, that our efforts would experience a similar opposition from prejudice and ignorance, we persevered in our object for a considerable time, and at last resolved to take out patents for England, Scotland, and Ireland, to secure to ourselves, for the usual term, the benefits of our invention; for the discovery was still as much our own as if nothing similar had been practised before; Ged's knowledge of the art having died with his son. The patents were accordingly obtained. As to benefits, however, I have as yet reaped none, and Mr. Foulis, I believe, has reaped as few, for owing to circumstances of a private nature, and which no way concern the public to know, the business was laid aside for a time, and having afterwards quitted Glasgow, and removed to London, I soon found myself so much occupied with other concerns that I have hardly had time to think upon it since. I ought, however, to observe here, that its being suspended was not on account of any imperfection attending the art, or objections against its being a fit subject to be prosecuted. On the contrary, several small volumes were printed from plates made by myself and Mr. Foulis, and the editions were sold to the trade without any intimation of their being printed out of the common way! We had heard whispers that our

work could not possibly be such as would pass for common printing! The trade knew what we were at, and would take care of any thing done in the new-fangled way. The first essays, therefore, were in the lowest sense of the word common: one or two histories, and a cheap edition of *The Economy of Human Life*. We also printed a Greek volume, Xenophon's *Anabasis*, 1783, and had plates for several small volumes of the English poets almost finished, but the latter were never put to press.'—*Philosophical Magazine*, vol. x. pages 272—275.

Stereotype printing is now practised in almost every country in Europe, but the mode of performing it differs almost in each of them. That adopted in this country generally is to make a mould in plaster of Paris taken from a page of types, to confine this mould in a box or pan made for the purpose, after the air and moisture are properly extracted, which is in about five minutes, and then to dip it into a pot of metal: the pan is lifted out by a crane or pulley, and the operation is completed. This department of the art of printing, though carried to an amazing extent within the last few years, is yet far from having obtained its maturity. The plan used by lord Stanhope, Mr. Wilson, and others, was so expensive as to deprive the publisher of almost all its advantages; it is now, however, executed on such an economical plan, and with such certainty and expedition, as to tempt its adoption for all standard works in the language, and indeed for every work where a second edition will be required.

#### PRESSES.

*Iron-presses.*—The art of printing has of late received very important improvements by the substitution of iron for wooden-presses. The advantages of the iron presses in working are very considerable, both in saving labor and time. The first arises from the beautiful contrivance of the levers, the power of the press being almost incalculable at the moment of producing the impression; and this is not attended with a correspondent loss of time, as is the case in all other mechanical powers, because the power is only exerted at the moment of pressure, being before that adapted to bring down the platten as quickly as possible. This great power of the press admits of a saving of time, by printing the whole sheet of paper at one pull, the platten being made sufficiently large for the purpose; whereas, in the old press, the platten is only half the size of the sheet.

For this change of the material of which presses are made, the trade are principally indebted to the late ingenious earl Stanhope. These presses, which still bear his name, have contributed very materially to the ease and beauty of the workmanship. There are likewise many other descriptions of iron presses, professing to be improvements upon the one suggested by lord Stanhope, but only one of them has obtained any celebrity, or possesses any superior advantages. This is the Columbian press, invented by Mr. Clymer; and from the amazing power of the



Fig. 1.

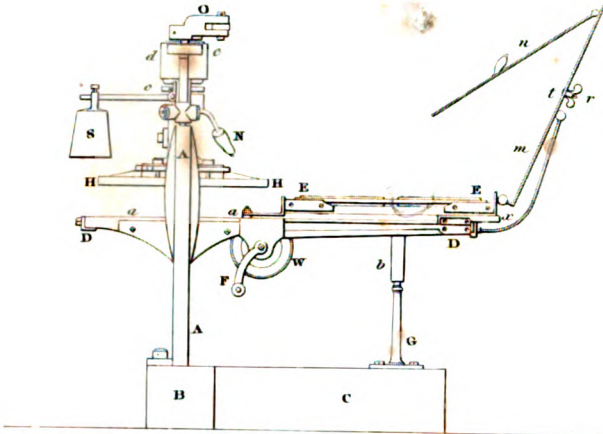


Fig. 2.

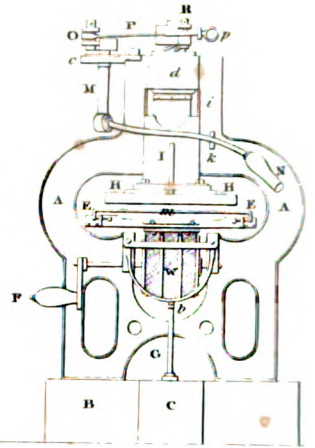


Fig. 4.

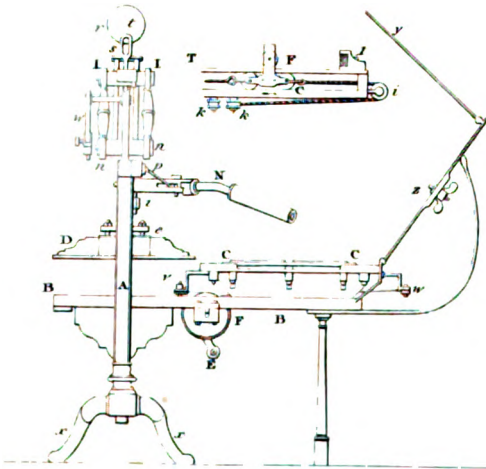
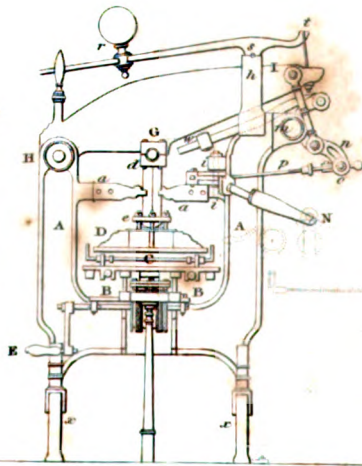


Fig. 3.



impression, the stability of the workmanship which it is next to impossible to break, as well as for other lesser advantages, perhaps will never be excelled. These two presses being now most in repute, we shall confine any minute descriptions to them alone, giving only a brief notice of several others, which have various degrees of merit.

The improved *Stanhope press* is exhibited in plate I. (PRINTING): fig. 1 is a side elevation; and fig. 2 a front view. A A shows a strong cast iron frame of the form represented in fig. 2. This frame is screwed down upon a piece of timber B, which has another timber C morticed into it at right angles, forming a frame in the shape of the letter T, to serve as a basis for the whole press. D D represent two horizontal rails, having channels formed along their upper surfaces, into which the two rails or ribs upon the underside of the carriage or table E E are adapted to slide. The carriage is put in motion by the action of the handle F and barrel W, which has three strong straps or belts passing round its circumference, as seen in fig. 2, the ends of the said belts being attached to the opposite ends of the carriage, in the manner of ordinary printing presses. The table E E is made perfectly flat upon its upper surface, in order to receive the form of the types: *m* represents the tympan, which is jointed to the end of the table; it is composed of a light frame of wrought iron, and fitted up in the usual manner.

The rails D, D, upon which the carriage runs, are secured to the main frame A A, by screw bolts *a, a*; the outer extremities of the rails D are united together by cross bars, and supported by an arched frame *v* and upright pillar G, the foot of which is bolted down to the timber C. H H represent the platen, which is guided in its perpendicular motion by a slide I, moving between angular ribs formed within the opening of the main frame, as seen in fig. 2. The upper part *d* of the frame is considerably enlarged, and is perforated in the centre to receive a brass nut or female screw, through which the main screw of the press works. M shows an upright spindle, the lower end of which is formed with a pivot adapted to turn in a hole at the top of the arch of the main frame; the upper part of the spindle M works through a collar *c*, formed in a piece of metal, which projects from the main frame, and is secured by a screw. N represents the handle of the press: it is firmly attached to the lower parts of the spindle M, and has a nut on the opposite side to keep it in its place. Thus, when the handle is moved backwards or forwards, it turns the spindle M round, and by the operation of the lever O, and connecting link P, the motion is communicated to the main screw, by the intervention of the arm or lever R fixed upon the top. The platen is raised up, and kept in contact with the end of the screw, by the operation of the balance weight S. The degree of pressure may be increased or diminished by the operation of the screw *p* at the end of the connecting link, being disposed so as to admit of varying the effective length of the link.

*Columbian press.*—A correct front view of this

press is represented in fig. 3, and a side elevation in fig. 4. A A shows the cheeks or main frame of cast iron; they are united together at the bottom, but separate at the top; the main frame is supported upon four legs, *x x*. B, B, represent the ribs or guides, upon which the carriage and table C C, with its appendages, is adapted to run, being moved backwards and forwards by the rounce E, and barrel F, round which strong linen belts are passed, and affixed at each end of the carriage, as in ordinary printing presses. D shows the platen, which is guided in its motion up and down by its square stem or pillar *d*, being placed angleways, and sliding between pieces of metal *a, a*; which project from the main frame A A. The pieces *a, a*, are furnished with adjusting screws and wedges, for the purpose of tightening them up, and preventing any looseness in the platen. The stem *d* has a square plate, *e*, upon it at the part where it joins to the platen. The pressure is produced by a combination of levers situated at the upper part of the frame. G, I, show the main lever, moving on a strong centre bolt at H, between a forked or divided part of the main frame; the end I of this lever also passes through an oblong opening formed between the bars *h*, and projects some distance beyond the outside of the frame. The central part G of the main lever has a strong pivot or trunnion cast upon it, which projects out sufficiently on each side to enter into collars formed at the top of the stem *d*, of the platen, being retained in their places by four screw bolts, two of which are seen at G in figure 3. *m, n, o*, show the second lever, moving on a fixed centre pin in the main frame at *m*; it has the links *n, I*, jointed to it at the point *n*; the uppermost ends of these links are also jointed on each side of the main lever at I. The point *o* of the second lever has the link or connecting-rod *p* jointed to it, whilst the opposite extremity of the connecting-rod is jointed to the lever or handle N, by which the pressman puts the system of levers into action. The handle N turns upon a fixed centre pin passing through projecting pieces of the main frame, as seen at *s s*; and the connecting-rod *p* is furnished with a double or universal joint, where it unites with the lever *o*, to admit of the oblique motion of the handle N, when it is pulled forwards to produce the pressure.

A counter-lever, *r s t*, is applied at the top of the press, moving upon a fulcrum at *s*; this lever has a balance weight in the form of an eagle clamped upon it by a screw at *r*, whilst the short end *t* of the lever is attached by a link to the end of the main lever at the end I. By this means the weight of the levers and platen is counterbalanced sufficiently to raise them up, when the handle N is left at liberty. The different levers in this press are so arranged that the first motion which is communicated to the handle N brings the platen down quickly; but, by the time that its under surface arrives upon the tympan, the second lever, *m n*, is brought nearly in a line with the direction of the links *n, I*, which causes them to draw down the end I of the main lever with great power; at the same time that the point *o*



of the second lever is in the most favourable position to be operated upon powerfully by the connecting-rod proceeding from the handle N. When the impression is produced, two balance weights act in concert to return the handle N, and raise up the platen.

The testimonies in favor of this press, by almost every master-printer who has used it, prove it to be the most complete press now in use; and at present appears scarcely susceptible of much improvement.

Several other presses are now in use, particularly the Albion press; but as they are somewhat similar in construction to the Columbian, though not so well approved, a particular specification need not be given. The Ruthven or horizontal press, invented by Mr. John Ruthven of Edinburgh, differs materially from all others, in the platen being moveable, and the types stationary. But, as it requires that a workman should almost learn his business over again to work at it, it is now seldom used. A beautiful and well-made press has lately been introduced into use by Messrs. Newman and Gillson, of Newark. Its power is produced by the use of inclined planes, and, these being fixed in a box which is well supplied with oil, the usual inconveniences experienced in that mode of obtaining pressure are in a great measure obviated. For all light work this press perhaps equals any press in use; but it is not adapted for large and heavy forms.

Several attempts have been made to apply a self-inking apparatus to the common press, and numerous patents have been obtained to this purpose; but as nothing has to this day been produced at all likely to succeed, however laudable and ingenious the attempts, we shall not supply any description of them.

*Of machine printing.*—Previous to the introduction of machines into the business of printing, the press department was one of great labor and difficulty, and the number of copies of a newspaper, which could be printed within the hour, seldom exceeded 750, even with extraordinary exertion. The consequence was, that in newspaper offices, where the circulation was extensive, it was found necessary, in order to get the paper published in time, to compose two or more copies, so that by going to press at the same time, the demands of the public might be complied with; thus occasioning an enormous increase of expenditure both in the compositors' and press departments. In a newspaper circulating 7000 or 8000 copies, this expense, annually could not have been less than £2000; all of which has been saved by the introduction of machines, which are worked by steam or hand.

The cylindrical mode of printing, which, in contradistinction to the old process, is called machine printing, was invented by the late Mr. Nicholson, well known in the scientific and literary world, who took out a patent in the year 1790, though it does not appear that his plans and experiments ended in any actually practical result. Whether M. König, who at a later period more successfully attempted to print by machinery, was indebted to Mr. Nicholson for his elementary principles, or whether almost the same ideas

spontaneously occurred to each individual, is a question that can only be satisfactorily solved by the former. Thus much is certain, that Mr König's labors were the first which produced any fruit; and, surely, more is due to him who, after years of persevering toil, succeeds in the application of hitherto unapplied principles, than to one of whom we can only say that he was simply the first to suggest ideas, since no evidence is offered of their ever having been acted upon.

M. König, by birth a Saxon, and by occupation a printer, many years ago conceived it possible to print by steam, though he then expected no more than to be able to give accelerated speed to the common press, to which end his first efforts were bent. As from the nature of such an undertaking, considering the state of scientific pursuits in his native land, he could calculate on little success unaided by others, and falling in his application for encouragement and support at the hands of the most eminent printers in several of the continental capitals, he turned his eyes towards England. Arriving in London, about 1804, he submitted his scheme to several printers of repute, who, not being disposed to incur the risk of property which a series of experiments were sure to entail, and perhaps, placing little confidence in a successful issue, received his overtures very coolly; and it is probable his applications in this country would have shared the fate of similar attempts abroad, had he not finally been introduced to Mr. Bensley, senior, who, attracted by M. K.'s plans, speedily entered into an arrangement with him. After a short course of experiments on the fabrication of a press which should have accelerated motion, and at the same time render the work of the man who inks the type unnecessary, the above gentlemen were joined by Mr. G. Woodfall and Mr. R. Taylor, the former of whom, however, soon retired; the remaining three, in no wise discouraged by the tediousness and expense which all who are conversant with the progress of any invention in machinery well know to be unavoidable, persevered amidst unforeseen perplexities, which were doubtless not diminished by the party's deficiency in practical mechanical knowledge. It was at length discovered that the intended improvement of the common press could not be brought to bear, and that much labor and prodigious expense would be thrown away, unless some radical alterations were invented. Cylindrical printing was now thought of, and, after some two or three years of renewed exertion, a small machine was brought forth, the characteristic of which was, that instead of the printing being produced by a flat impression (similar to the press), the sheet passed between a large roller and the types still flat; and, in lieu of the old-fashioned balls, used by hand to beat over the types, and to communicate the ink to their surface, skins were strained round smaller rollers on which it was contrived to spread the ink, and under which the form, i. e. the frame in which the types are fixed, passed in its way to the printing cylinder. Considerable promise of success attended this production; and, after continued experiments, it was deemed practicable to

extend the general principles to a more powerful machine. To print a newspaper was considered highly desirable; and on exhibiting to Mr. Walters, proprietor of the Times newspaper, the machine already erected, and showing what further improvements were contemplated, an agreement was entered into with that gentleman for the erection of two large machines for printing his journal. So secret had been the operations of the patentees that the first public intimation of their invention was given to the reader of The Times on Monday, the 28th of November, 1814, who was told that he then held in his hand one of many thousand impressions thrown off by steam. At this time but few persons knew of any attempt going on for the attainment of the above object; whilst, among those connected with printing, it had been often talked of, but treated as chimerical.

The machines at the Times Office, cumbersome and complicated as subsequent improvements have made them appear, were yet in many respects admirably adapted to the purpose for which they were erected.

The next advance in improvement was the manufacture of a machine for Messrs. Bensley, distinguished from those before mentioned by the mode of *perfecting* (or printing on both sides), so that the sheet of white paper is placed in the feeder and delivered from the machine printed on both sides! In addition to the essential difference between this machine and those previously made, it came forth with many obvious improvements, though still unquestionably complex:—and for the first attempt at effecting register (causing the pages to fall precisely on the back of one another), a greater degree of success than might have been expected was attained, subsequent experience showing the many difficulties to be surmounted in the accomplishment of this object. Deficiencies were now detected in the *inking*: the strained skins were found uneven in their surface; and attempts were made to clothe the rollers with an elastic preparation of glue, treacle, &c., which has at length attained perfection.

By this time the invention had attracted the attention of various individuals, who thought the manufacture of printing machines an easier task than they afterwards found it to be; and far the greater number of attempts, we believe, failed almost as soon as undertaken. A machine, however, similar in its capacities to that last mentioned, but much more simple in its construction, has been brought out, under the direction of some eminent English engineers. It was not long before these gentlemen were requested to apply their inking apparatus to Messrs. Bensley's machine, and at one stroke, as it were, forty wheels were removed—so great was the simplification: and at the same time the defects of the former system, of communicating the ink to the types, were most effectually remedied. Massive and complicated as it was, yet as an immense expense had been incurred in its erection, Messrs. Bensley went on using their machine until the destruction of their establishment by fire in 1819. - And, even after the rebuilding of the premises, the machinery, which had been

only partially damaged, was reinstated, and worked for some time: it has now, however, given place to two large and admirable machines built on the improved plan, which, when inspected by a judicious eye, can create only wonder at the heretofore circuitous manner adopted to attain ends so apparently within easy reach. The original machine contained upwards of 100 wheels; whereas the new machine, with about ten wheels, accomplishes, in point of quantity, exactly the same object, with a marked advantage in regard to the quality of the printing. Another important point respecting the new machine is, that it occupies scarcely half the space of the original one.

This machine, notwithstanding the improvements which had been made upon it, has lately been replaced by one made by Augustus Applegarth, esq., several of whose machines are at present in use in the metropolis; and recently several have been exported to the continent. All the machines of his construction are worked by steam; but there are others which have for some years been brought into use which are turned by a fly wheel; and of course have the advantage of being far less cumbersome, and more applicable to the general purposes of the trade. One was invented by Mr. W. Nicholson, of London, for which a patent was obtained 29th April, 1790; a second by Mr. Bacon of Norwich, and made by Bryan Donkin, esq., of London; another was the invention of the late Charles Brightly, esq., of Bungay, and executed by the same engineer; none of them, however, have been brought into practical adoption, though they each possessed a considerable share of merit, and were constructed at a very great expense.

The adoption of printing machines rendered necessary a new mode of distributing the ink upon the type, and which is now transferred to the common press. The original mode was to moisten sheep-skins in liquor, to fasten them round a ball of wool, and then, having procured two of them, the ink was distributed on the surface of each by working them together. This is now entirely superseded by the use of rollers. These rollers are a composition of glue and treacle, which, when heated into a liquid state, are cast in a mould, round a cone of hard wood; and, when cold, are extracted from the mould, and are soon fit for use. This method of inking forms one of the most valuable improvements in modern printing; as it not only affords considerable ease to the workmen, but is calculated to perform the operation with much greater regularity and certainty.

The machines worked by hand now most in repute are those manufactured by Mr. D. Napier. They print both sides the sheet at one operation; and are calculated to do the work of about six or seven presses. This ingenious mechanist is now contriving one for printing newspapers, which is estimated to take off 300 impressions per minute,—a speed almost incredible. As this with some other machines for printing by the same engineer, are not yet completed, we must refer a minute description of them to the article *TYPOGRAPHY* which see.

**PRINTING, COPPER-PLATE**, requires some notice, though we hardly know a modern art or trade that has been so little improved in the mode of conducting it. It is performed by a machine called the rolling-press, which may be divided into two parts, the body and carriage.

The body consists of two cheeks of different dimensions, ordinarily about four feet and a half high, a foot thick, and two and a half apart, joined at top and bottom by cross pieces. The cheeks are placed perpendicularly on a wooden stand or foot, horizontally placed, and sustaining the whole press. From the foot likewise rise four other perpendicular pieces, joined by cross or horizontal ones, which may be considered as the carriage of the press, and as serving to sustain a smooth, even plank, about four feet and a half long, two feet and a half broad, and an inch and a half thick; upon which the engraven plate is to be placed. Into the cheeks go two wooden cylinders or rollers, about six inches in diameter, borne up at each end by the cheeks, whose ends, which are lessened to about two inches diameter, and called trunnions, turn in the cheeks between two pieces of wood, in form of half moons, lined with polished iron to facilitate the motion. The space in the half moons left vacant by the trunnion is filled with paper, pasteboard, &c., that they may be raised and lowered at discretion; so as only to leave the space between them necessary for the passage of the plank charged with the plate, paper, and blankets. Lastly, to one of the trunnions of the upper roller is fastened a cross, consisting of two levers or pieces of wood traversing each other. The arms of this cross serve in lieu of the handle of the common press; giving a motion to the upper roller, and that to the under one; by which means the plank is protruded, or passed between them.

The printing is performed nearly as follows:—The workmen take a small quantity of the ink on a rubber made of linen rags, strongly bound about each other, and with this smear the whole face of the plate as it lies on a grate over a charcoal fire. The plate being sufficiently inked, they first wipe it over with a foul rag, then with the palm of their left hand, and then with that of the right; and, to dry the hand and forward the wiping, they rub it from time to time in whitening. In wiping the plate perfectly clean, yet without taking the ink out of the engraving, the address of the workman consists. The plate thus prepared is laid on the plank of the press; over the plate is laid the paper, first well moistened, to receive the impression, and over the paper two or three folds of flannel. Things thus disposed, the arms of the cross are pulled, and by that means the plate with its furniture passed through between the rollers, which, pinching very strongly, yet equally, press the moistened paper into the strokes of the engravings, whence it licks out the ink.

**PRINTING OF CALICO.** The art of printing in colors is intimately connected with many of the chemical processes we have already described under the article **DYEING**; we shall therefore avoid any unnecessary repetition of those details by occasional references to the various sections of that treatise. This ingenious art

consists in dyeing cloth with certain colors or figures upon a ground of a different hue. The colors are usually fixed by mordants that have various degrees of chemical affinity for the body to be employed.

The art of calico printing is of considerable antiquity, and we have seen some Egyptian cotton dyed by figured blocks many hundred years old. A similar process has long been resorted to in the Sandwich Islands, though they usually employ a large leaf as a substitute for the block.

A popular view of the process of printing calicoes may, however, be furnished prior to a more scientific analysis of the various processes. Some calicoes are only printed of one color, others have two, others three or more, even to the number of eight, ten, or twelve. The smaller the number of colors, the fewer in general are the processes.

One of the most common colors on cotton prints is a kind of nankeen yellow, of various shades, down to a deep yellowish brown, or drab. It is usually in stripes or spots. To produce it, the printers slightly coat a block, cut out into the figure of the print, with acetate of iron, thickened with gum or flour; and apply it to the cotton, which, after being dried and cleansed in the usual manner, is plunged into a potash ley. The quantity of acetate of iron is always proportioned to the depth of the shade. For yellow the block is coated in a similar way with acetate of alumina. The cloth, after receiving this mordant, is dyed with quercitron bark, and then bleached. Red is communicated by the same process; only madder is substituted for the bark. The fine light blues which appear so often on printed cottons are produced by applying to the cloth a block covered with a composition, consisting partly of wax, which covers all those parts of the cloth which are to remain white. The cloth is then dyed in a cold indigo vat; and after it is dry the wax composition is removed by hot water. Lilac, flea brown, and blackish brown, are given by means of acetate of iron; the quantity of which is always proportioned to the depth of the shade. For very deep colors, a little sumach is added. The cotton is afterwards dyed in the usual manner with madder, and then bleached. Dove-color and drab, by acetate of iron and quercitron bark. When different colors are to appear in the same print, a greater number of operations are necessary. Two or more blocks are employed, upon each of which that part of the print only is cut, which is to be of some particular color. These are coated with different mordants, and applied to the cloth, which is afterwards dyed as usual.

Dr. Ure furnishes the following important observations on calico printing, for which he states that he is indebted to a much esteemed friend, who unites scientific knowledge to practical skill. It occurs in the second volume of Berthollet's Art of Dyeing.

To bleach cloth for printing, it is first of all to be singed, and then steeped in warm water (sometimes with an addition of spent ley) for a day or two. It is then well washed and boiled in potash ley, five different times.

For 2000 lbs. (original weight) of cloth, 1000

gallons of water, and forty to forty-five lbs. of potash are employed each time. The boiling is continued eight or ten hours.

Between each operation the cloth must be well washed, and after the third and fourth boil it must be spread upon the grass, or steeped for a night in a weak solution of chloride of lime. After this it is winced a few minutes in a warm dilute sulphuric acid, well washed, and dried.

The principal processes, or rather styles of work, as they are called, are the following:—

1. Single colored plates.
2. Ditto ditto grounded.
3. Light or dark chintzes.
4. Dark grounds, with a white discharge.
5. Blue grounds with a white resist.
6. Blue grounds, with a red and white resist together.
7. Chemical or spirit colors.

1. *Single colors* are called plates from their being generally printed with the copper plate. This process consists generally in printing a mordant upon the cloth; which mordant attracts a coloring matter when the cloth is dyed. The mordant is different, according to the color that is wanted.

For *black*. An acetate of iron is used of the specific gravity 1.040.

For *purple*. An acetate of iron, specific gravity 1.12, with six, eight, or twelve times its volume of water, according to the shade of color required, and the mass to be printed.

For *red*. A solution of three pounds alum in a gallon of water, one half of which is decomposed by acetate of lime or lead.

For *chocolate*. Mixtures of acetate of iron, specific gravity 1.12, with red mordant, in the proportions of one to two, four, six, according to the shade.

Each of these mordants is thickened with flour, or in some cases with gum, and printed upon the bleached cloth. After being exposed to the air for a few days, in a warm room, the goods are taken down and passed through the dung copper at a heat of from 150° to that of boiling water. They are then washed, and winced in another clean dung copper, at a lower degree of heat than before, and then washed again. They are now ready to be dyed.

All the colors last mentioned, viz. black, purple, red, and chocolate, are dyed with madder and sumach, except purple, in which the sumach is omitted. Different quantities of madder are used, according to the quantity of color on the cloth, from one pound per piece of twenty-one square yards, to three and even three and a half pounds; the sumach about one-eighth of the madder. The goods are entered when the copper is cool, and the heat is brought up gradually during two or three hours, and sometimes the ebullition is kept up for a quarter of an hour; the pieces all the while being turned over a wince, from the one side of the copper vessel to the other. They are then washed, and boiled in bran and water ten or fifteen minutes. If they have much white, they must be brained a second and a third time, washing between each operation. To complete the whitening, they are spread upon the grass for a few days; or what is

more expeditious, and more generally practised now, they are winced a short time in a warm but weak solution of chloride of lime.

For *indigo blue*. A strong solution of caustic potash is made, in every gallon of which, by the aid of as much orpiment, twelve or sixteen ounces of good indigo is dissolved. This solution, when clear, is thickened with gum. This being printed upon the cloth, nothing more is necessary than to wash it when dry.

For *Prussian blue*. The same mordant is used as for black; but, after cleansing, the piece is winced in a solution of prussiate of potash, in which the prussic acid has been set free by means of sulphuric acid.

For *gold*. Five pounds sulphate of iron and one pound and a half acetate of lead are dissolved in a gallon of water: the solution, thickened with gum, is printed on the cloth; and, after eight or ten days' age, is winced in a solution of potash made thick with lime. As soon as the black oxide of iron, which is precipitated, commences to redden, the piece is removed to a vessel of water, and then washed.

2. A second, and sometimes third color, is grounded or printed in with a small block, generally after the first has been dyed.

*Bark yellow*. A mordant is used, the same as for red. The piece, when slightly dunged, is dyed about an hour with one pound of quercitron bark, the infusion being gradually heated during that time to 130° or 160°.

*Berry yellow*. A decoction of French, or Turkey, or Persian berries, with half a pound of alum per gallon, is thickened with flour or gum; and the piece, when dry, is passed through a weak alkaline carbonate, or lime-water.

*Verdigris green*. A solution of sulphate and acetate of copper is put on cloth, which is then passed through a strong solution of potash, in which some protoxide of arsenic has been dissolved.

*Drab*. The same mordant as is used for purple. Bark, the dye stuff.

*Olive*. The chocolate mordant dyed in bark. Both these very much diluted, and thickened with gum.

*Buff*. A weak acetate of iron is applied, and washed in water.

3. *Chintzes*.—A number of different colors printed upon cloth together, viz. black, red, one or two pale reds, purple, blue, green, and yellow. The black, red, and blue, are the same as in No. 1; the purple as No. 1 thickened with gum; the two pale reds are weaker solutions of alum and acetate of alumina, thickened with gum; the yellow is berry yellow, applied after the other colors are finished; the green is formed by the yellow falling upon the blue; and all the varieties of orange, olive, &c., by its falling upon the pale reds and purple. The dyeing and subsequent bleaching are the same as has been described in No. 1, with madder only.

4. *A dark ground discharged*.—When the discharge is printed before the mordant, it consists of concentrated lime juice alone, thickened with gum. The mordant, which is also thickened, is blotched over the whole piece, and dried off it as quickly as possible. When the mordant is applied first it is not thickened,

and the acid has an addition of one pound bisulphate of potash in each gallon. They are dunged and dyed like other single colors. Blacks, instead of madder, are generally dyed with logwood and galls.

5. *Blue grounds*.—To make a blue paste for dark blues, three or four pounds sulphate of copper are dissolved in a gallon of water, with a pound or a pound and a half of acetate of lead. The clear solution is thickened with pipe-clay and gum. The pieces printed with this paste are hooked upon a frame, and dipped in a weak blue vat five or six times; then taken out and kept in the air till they become blue. Alternate immersions and airings are thus continued till the requisite shade has been obtained. The goods are then washed and dipped in a weak sulphuric acid, to dissolve the oxide of copper. The blue vat, as is well known, is made by one part of indigo, with two parts sulphate of iron, and about two and a half parts hydrate of lime.

6. A mordant for red, to resist the blue vat, is made by dissolving about four ounces acetate of copper in a red mordant, made from four pounds of alum, and two pounds and a half acetate of lead per gallon, and thickening the solution with pipe-clay and gum. When this is printed upon the cloth, and dipped in the blue vat, it resists the blue, and a white is left, which, when dunged and dyed in madder, becomes red.

A white called *neutral* is made by dissolving sulphate of copper in concentrated lime juice, and is used along with this red. It must possess the three following properties:—1. Resisting the blue; 2. Remaining white after dyeing, when the red happens to go over it; 3. To leave no oxide of copper upon the cloth.

A berry yellow is grounded in after the blue, white, and red, in this style, are finished.

7. *Chemical colors*.—This name has been given to those colors which are applied topically; most of them are fugitive.

*Black*. A decoction of logwood and galls, thickened with flour, and, when cold, nitrate of iron mixed with it.

*Red*. A decoction of Brasil or peach wood, with the protomuriate or perniuriate of tin.

*Purple*. A decoction of logwood with muriate of tin.

*Blue*. Ground Prussian blue is soaked in muriatic acid for a day or two, and then as much of it mixed with gum tragacanth water as is sufficient to give it the desired shade.

*Yellow*. A decoction of fustic with muriate of tin.

*Green*. A mixture of the blue and yellow.

All these colors are simply washed off in water.

M. VITALIS gives the following prescriptions in calico-printing:—

*Mordant for reds*. 240 litres of boiling water; 150 pounds of pure alum; fifty pounds of acetate of lead; six pounds of commercial potash or soda; six pounds of chalk; three pounds of ground Brasil wood.

Into a vat capable of holding 400 litres, and partly filled with the 240 litres of boiling water, the alum in powder is put, and then the decoction of Brasil wood. After stirring till the alum is dissolved, the acetate of lead in powder is

added. The mixture is to be carefully stirred for some time, and, when the liquor begins to clarify, the potash is put in, then the chalk, in small portions at a time, to avoid too great an effervescence. The whole must now be stirred for an hour and left to settle. The clear liquor is used as occasion requires.

For strong reds (full reds) the above mordant is thickened with starch. This is called *first red*.

If reds of a weaker tone be wanted, the mordant is thickened with gum.

For the *second red*, three pints of the mordant are thickened with two pounds and a half of gum dissolved in a pint of cold water. The whole is well mixed by due agitation.

For the *third red*, two litres (a pot) of mordant are mixed with the solution of five pounds of gum, dissolved in three pots of cold water.

The above red mordant serves also for weld fustic and queciron yellows, with all their shades.

*Mordant for blacks*. Twelve pints of iron liquor (pyrolignite of iron). Four ounces of copperas.

Dissolve the copperas in the liquor; and, after having decanted the clear, mix in gradually four pounds of starch. Heat in a boiler, stirring continually, and take it out when the starch is well boiled.

*Another black mordant*. For eight pounds of iron liquor, take about two pounds and a half of superfine wheat flour, which is to be gradually mixed up with a portion of the liquor; then add the remainder of this, and leave at rest for twelve or twenty-four hours, or even longer. Then boil for half an hour, or till the mixture has acquired the consistence of a paste. The boiler is then to be removed from the fire, and the mordant is to be stirred till it becomes cold. It is now to be passed through a sieve, and used in printing.

These mordants give a beautiful black with logwood, and especially madder.

Under the Chemical Black, in Rees's Cyclopaedia (article COLOR), we have the following recipes:—

To a decoction of Aleppo galls, in five times their weight of water, made into a paste with flour, add a solution of iron in nitrous acid, of specific gravity 1.25, in the proportion of one measure of nitrate of iron to eighteen or twenty of the decoction, and a black will be formed fit for almost all the purposes of calico printing; and possessing the chief requisites of this color, namely, tolerable fixity, and a disposition to work well with the black.

When a nitric solution of iron is added to a decoction of the galls, the solution is decomposed, the oxide of iron unites with gallic acid and tanning principle, while the nitrous acid is disengaged. This appears from the blackness which the solutions assume immediately on being mixed. The disengaged acid, however, re-acts in a short time on the new compound, the blackness gradually disappears, and, if the nitrate of iron has been added in proper quantity, the paste in a few days becomes, from a black, of a dirty olive green. When the proportion of nitrate of iron is greater than one-eighteenth, this change takes place sooner; and, if it amounts to one-tenth, the paste, when applied to the cloth,

will be a bright orange, like the acetate of iron. By exposure to heat and air this color generally deepens, becoming gray, and at last a full black. In this state it is permanent, and adheres powerfully to the cloth.

These changes of color depend on the solution of the tannate and gallate of iron in the disengaged nitrous acid, and the dissipation of the acid from the cloth, when it is exposed to heat and air. This solution of the tannate and gallate of iron is indeed an essential requisite to the goodness of the chemical black. If the disengaged acid is not sufficient to effect this, or if it is in a state of too great dilution, the color has but a feeble adherence to the cloth. It is not presented in a state favorable to its union with it, since the combination into which the iron has entered is insoluble in water. It lies merely on the surface, but does not penetrate its fibres, and gives way readily in the various operations to which it is subjected. This chemical black, therefore, is a solution of the tannate and gallate of iron in nitric acid.

*Mordants for violets* (from Vitalis). *First violet*.—Sixteen pints of iron liquor; eight pints of water; four ounces of Roman vitriol (sulphate of copper). This mixture is to be thickened with powdered gum, in the proportion of a pound to the pint.

*Second violet*.—Mix three parts of the preceding with one of water, and thicken as above.

*Third violet*.—Dilute two parts of the first mordant with three of water.

*Coffee color*.—Ten pints of iron liquor; two pints of the mordant of the first red; four pints of water. Thicken with starch.

*Puce, or carmelite color*.—Three pints of mordant of the first red; half pint of iron liquor.

*Deep brown*.—Two pints of red mordant; half pint of iron liquor.

*Maroon color* (chestnut-brown).—Two pints of violet mordant; one pint of red mordant; eight ounces of green copperas, to be dissolved in the mixed mordants.

*Mordori*.—Eight pints of violet mordant; twelve pints of red mordant.

*Deep lilac*.—One pint of violet mordant; one pint of mordant for the second red.

*Light lilac*.—One pint of violet mordant; three pints of mordant of the second red.

*Mask color*.—One pint of red mordant; three pints of black mordant.

*Incarnate (flesh) color; color between cherry and rose*.—Ten pints of red mordant; one pint of black mordant.

*Olive color*.—Welding on the mordant of the first, second, or third violet.

*Rosida color*.—Welding on puce mordant.

We may now select from Vitalis some examples of the mode of managing the different styles of calico printing. We shall place them in the order in which they occur under each head. We may commence with

*Calicoes of one block*.—First example. Violet on a white ground. 1. Impression of violet mordant; 2. Dyeing and washing; 3. Madding; 4. Branning and exposure on the grass for a few days, to clear the grounds.

Second example. Black on a yellow ground.

1. Bath of yellow mordant; 2. Welding; 3. Topical black.

*Calicoes of two blocks*.—First example. First olive and second olive on a white ground. 1. Impression of the first olive mordant; 2. Impression of the second olive mordant; 3. Welding.

Second example. Red and blue on a white ground. 1. Impression of the red mordant; 2. Madding; 3. Impression by the block of topical blue. When the calico is to have several colors, says M. Vitalis, for example, black, several reds, several violets, &c., as many mordants must be given as there are different colors, which must be inserted (rentrés) into the first plate (figure), called the plate of impression (printing block, planche d'impression). The insertion (rentrage) of the mordants is executed by means of blocks (planches), which take the name of rentreures. These blocks are engraved with the same patterns as the printing blocks, but so as that they apply the new mordants only to the places of the pattern reserved in the first blocks.

It may be readily conceived how necessary it is for these blocks to have an exact correspondence with one another, otherwise the colors would not be comprised within the limits of their outlines. This fault is too often met with in common prints, on account of the rapidity with which they are worked off, and the little care taken in their fabrication. In order that every color may occupy the place assigned to it in the drawn pattern (le dessein enluminé), adjusting brass points (picots de rapports) are made use of, which guide the printing on of the successive mordants, at precisely that place of the figure where the color to be produced from each mordant ought to fall.

Third example. Yellow and black on a white ground. 1. Impression of the yellow mordant, welding; 2. Impression of topical black.

*Calicoes of three blocks*.—Example. First olive, second olive, and yellow on a white ground. 1. Impression of the first olive mordant; 2. Impression of the second olive mordant; 3. Impression of the yellow mordant; 4. Welding.

The third block (main) might also be performed by the impression of the topical yellow.

*Calicoes of four blocks*.—Example. Black, red, violet, and yellow on white. 1. Impression of the black mordant; 2. Impression of the red mordant; 3. Madding; 4. Impression of topical yellow, or of the yellow mordant, and welding.

*Calicoes of five blocks*.—Example. Black, red, violet, yellow, and blue. 1. Impression of the black mordant; 2. Impression of the red mordant; 3. Impression of the violet mordant; 4. Madding, insertion of the blue, and afterwards of the yellow.

*Calicoes of six blocks*.—Example. First olive, second olive, black, first red, second red, and yellow on white ground. 1. Impression of the black mordant; 2. Impression of the first red mordant; 3. Impression of the second red mordant; 4. Madding; 5. Impression of the second olive mordant; 6. Impression of the yellow mordant; 7. Welding.

It is now very seldom, however, that the num-

ber of three blocks (courses) is exceeded, on account of the high price to which the labor would necessarily raise the calico. The following is an example of printing in fugitive colors: violet, black, red, and yellow, on white ground. These four topical colors are successively applied, in the order above mentioned.

Calicoes with fast colors, after receiving the impressions, are dried, and washed from the mordants, when they are ready for the maddering.

Goods printed by reserve are so called, because the color does not strike the whole surface, but only certain unprotected portions of it. The reserve is composed of the reserve bath, and the thickening.

A *reserve bath* is thus formed: dissolve in a pint of water six ounces of sulphate of copper, three ounces of verdigris, two ounces of alum, and four ounces of gum arabic.

Another *reserve bath* may be noticed: dissolve in two litres of water four ounces of Roman vitriol (sulphate of copper), and six ounces of verdigris, to which add one pound of gum arabic; and, when it is dissolved, pass through a fine sieve, or let it settle, and decant.

To thicken the bath, knead a pound of pipe-clay, well ground and sifted, with three or four ounces of water: with this thick dough carefully mix the reserve bath, and triturate well before making use of it. The reserve is printed on the goods like the mordants. Twenty-four hours after the impression the goods are to be passed through the dyeing vat. This style is much used in blue dipping.

The theory of the reserve is very simple. The oxide of copper, which forms the basis of the reserve, restores to the indigo the oxygen which it had been deprived of by the sulphate of iron. The reoxygenated indigo loses its solubility, and consequently cannot fix on the stuff. Since the reserve, intended to nullify the action of the indigo essentially, acts merely by the oxide of copper which it contains, it follows that the proportions of this oxide are not indifferent, and that the measure will not perfectly accomplish its end, unless the dose of oxide of copper, which the sulphate, &c., can furnish, be adequate to neutralize the action of the indigo. A similar result would ensue, if the reserve be not suitably thickened. Some object to the introduction of alum.

The proportions of the cupreous salts ought, however, to be as little as can effect the purpose; if their quantity be too great, their operation would be extended to the indigo diffused through the bath. Sometimes the sulphate of copper is made to predominate, and sometimes the acetate.

The following recipes for reserves are given by M. Vitalis:—

1. Sulphate of copper	. . . . .	20 pounds
Acetate of copper	. . . . .	12
Gum	. . . . .	16
Alum	. . . . .	5
Water	. . . . .	32 litres
2. Sulphate of copper	. . . . .	16 pounds
Acetate	. . . . .	24
Alum	. . . . .	4
Gum	. . . . .	15 lb. 8 oz.
Water	. . . . .	8 litres.

The thickening is always made with pipe clay.

To make a sky-blue on a dark blue.—1. Dye the cloth of a sky-blue; 2. Apply the usual reserve; 3. Pass the cloth through a strong blue vat. Brighten in a bath, feebly acidulated with oil of vitriol (or muriatic acid), to carry off the particles of lime suspended in the vat. Wash and dry.

Sky-blue, dark-blue, and white.—1. Apply the reserve; 2. Dye sky-blue; 3. Apply the reserve anew; 4. Pass through a blue vat of sufficient strength.

Deep blue, sky-blue, green, yellow, and white.—

1. Print on the reserve; 2. Pass through a weak vat, giving two or three dips; dry, brighten with very dilute sulphuric acid, wash, dry again; 3. Print on once more the common reserve paste; 4. Dye in a stronger vat than the above, till the blue be sufficiently deep; dry, brighten as before, wash and dry; 5. Print on the red mordant, and dry; 6. Give the weld or quercitron. The mordant applied to the white spots, and to the pale blue (petit blanc), affords yellow and green. The white portions that have not been touched with the mordant remain white, in like manner as the pale blue spaces, not covered by this mordant, furnish the pale blue. Reserves are also applied to silks. For example, on the handkerchiefs called foulards, the reserve is styled waxing. A mixture of tallow and resin is melted, and applied to the silk with the block; this reserve being given, the silk is dipped in the blue vat. The reserved portions, being defended from the action of the indigo, remain white, while the rest of the surface takes a fast blue.

Sky-blue, red, and white.—1. Apply the usual reserve; 2. Apply the red mordant, thickened with pipe-clay, and dry; pass through a weak blue vat, to obtain sky-blue; wash at the river, madder, wash, and spread out on the grass to clear the white.

Printing with discharges (*par rongement*) on a mordant.—This process serves to form mourning garments, composed of a white figure on a black ground. The piece of goods is first passed through the black mordant by means of the padding or blotching machine. When this mordant is very dry (by passing, for example, over steam cylinders), the white discharge is applied, prepared with nitric, oxalic, tartaric, or citric acid, or bisulphate of potash, thickened with roasted starch (British gum). It is dried, washed, and maddered. On quitting the madder bath, the goods must be well washed, and exposed on the grass till the whites be very clear.

The portions of the cloth where the mordant has not been acted on by the discharge will take a black of a greater or less depth from the madder, while, on those places where the discharge has been applied, the mordant will be removed, and the madder color will not combine with the stuff. Exposure on the grass will carry off the loose madder. In like manner, by this process, white figures may readily be obtained on a ground of red, carmelite, violet, puce, &c.; since it will be necessary merely to pass through the mordant of one of these colors, then to apply the white discharge, and finally to madder. To have white figures on an olive ground, weld or quercitron must be used instead of madder.

*Printing with a discharge on color (dyed goods).*—Suppose that the calico has been dyed in a logwood bath, mixed with iron liquor, the cloth will take a black color. If, after dyeing, it be impressed with a solution of tin, properly thickened, the ferruginous portions of the cloth touched with the discharge will be removed, and they will pass from a deep black to a very brilliant crimson.

By subjecting to the same treatment calicoes dyed of different colors and shades, determined by the different degrees of oxidization of the iron, a multitude of varieties will be produced, either in the colors or in their shades.

By a similar operation, we may make figures of a beautiful green on goods, by dyeing them first of a pale blue in the indigo vat, passing them then through a bath of sumach and sulphate of iron, and finishing in a bath of quercitron with alum.

Here the green color produced by the indigo and the quercitron remains masked, as well as the other colors, by the oxide of iron in the sulphate, till the solution of tin be applied, which causes the other colors to disappear, and gives to those that remain a lustre which they would not otherwise have had; because the solution of tin renders the quercitron yellow more vivid, and because from this vivid yellow, associated with the blue, results a more brilliant green.

A figure of aurora color on an olive ground may be made, by passing the cloth first through a bath of sumach and sulphate of iron, then washing in an alkaline decoction of fustet, and printing on at last the solution of tin.

Let us give for an example the mode of making yellow figures on olive. The problem is reduced to find a discharge, which, in destroying the color communicated by iron, can at the same time change the color to yellow. This discharge is the thickened solution of tin. To the solution of salt of tin (muriate) a little muriatic acid is added. This is thickened with starch previously boiled, in a very thick and cold state, observing to pour in the solution in small portions, in order to ensure the thorough union of the ingredients. As soon as the piece has been impressed with this discharge, it is carried to the river to be washed, and to prevent the discharge from acting too long on the color. If the pattern required black, it would be necessary to apply it before the yellow discharge.

*Calico printing by the combined methods of discharges on the mordant and on the dye.*—First example. Olive, yellow, and white. 1. Pass through the olive mordant. 2. Print on the white discharge; wash and dry. 3. Weld. 4. Print on the yellow discharge.

Second example.—Bright red, and dull red; white, yellow, and black, on an olive ground. 1. Print on the red mordant. 2. Madder. 3. Pass through the olive mordant. 4. Print on the white discharge. 5. Weld. 6. Print on the yellow discharge and the topical black, and wash.

The colors by discharges, though bright, are not so fast as those given by the dye-baths. If, instead of applying the yellow discharge, thickened as usual with starch, one-third more starch be employed, and a coloring of decoction

of Turkey berries, or Brasil wood, be added we shall obtain, in the first case, a richer yellow. and, in the second, an orange yellow.

The name of *lapis lazuli* is given to calicoes, which, after having been printed with reserve discharges, and different mordants, are passed in succession, first through the blue vat, and then through a madder bath. If a yellow or a green be wanted, there is given, in the sequel of the madder washing, a yellow mordant, and the goods are turped through a bath of weld or quercitron.

Suppose that we are to print on cloth a pattern into which there enter white, red, black, blue, green, and yellow. The goods being previously thoroughly whitened, we proceed as follow:—

1. Apply the reserve discharge.
2. Print on the red mordant, thickened with pipe-clay.
3. Print on the black mordant, thickened in the same manner.
4. Pass the goods through a strong vat in forty-eight hours at farthest after the printing has been given. The dipping ought to be for six minutes at most at two times: between each dip, the goods must be aired for five minutes. They are then carried to the river, allowed to steep in it for an hour, and washed.
5. They are dunged.
6. Passed through bran.
7. Madder.
8. Beetled very carefully and dried.
9. The red mordant is applied, which serves also as a yellow mordant. The pieces are now to be well cleaned.
10. They are passed through the quercitron bath, after which they are washed and finally dried. It may be proper to add that the reserve discharge is prepared by melting together hog's-lard and resin (arcanson), and, when the mixture is cool, diluting it with oil of turpentine; adding afterwards binarseniate of potash, and a little corrosive sublimate in powder. The whole, being well blended or ground together, is to be then printed on.

The lapis pattern may be put on a blue ground, a red, green, puce, &c.; whence result a great many varieties. The pattern was originally called lapis, from its resemblance to lapis lazuli. A slight reflection on the above process will show us how the different colors are produced.

The blue is the immediate effect of the blue vat; the red and black are developed by the madding on the respective mordants of these colors. The combination of blue with yellow on the yellow mordant gives green. The yellow results from the coloring matter of the quercitron bark fixed by the red mordant, which is, at the same time, the mordant for yellow. Finally, the white is occasioned by the white discharge of the reserve discharge.

The calico printer should be well acquainted with the nature of topical colors, or 'colors of application,' as they are sometimes called. The following are from Vitalis:—

*Topical or pencil blue.*—Boil in sixty pints of water, for half an hour, fifteen pounds of potash, and six pounds of quicklime, in order to render the potash caustic. Then add six pounds of orpiment (sulphuret of arsenic) reduced to fine power, and continue the boiling for a quarter of an hour, taking care to stir continually with a rod. When the boiler is a little cooled, pour into



it from six to eight pounds of indigo well ground at the mill, and stir again till the indigo be well dissolved, which is discovered by a drop of the liquor, when placed on a bit of glass, appearing yellow. The bath, while still hot, is to be thickened with a pound of gum for every pot (two litres) of liquor, or with eight ounces of starch. This operation must be carefully preserved from contact of air, and only employed when its color is yellow, or at least yellowish-green. If it become blue, the liquor is to be treated anew with some pounds of caustic potash and orpiment.

This blue application, says M. Vitalis, much used formerly, is seldom employed at the present day. Another blue, of less permanence, but more brilliant, is now preferred. It is made with Prussian blue, in the following manner:—Into an earthen pot, four ounces of finely ground and sifted Prussian blue are to be put. Over this must be slowly poured, stirring all the while sufficient muriatic acid, to bring it to the consistence of syrup. The mixture is to be stirred every hour for a day, and afterwards thickened with from four to eight pots (of two litres each) of gum-water, according to the shade wanted.

*Topical red.*—A pound of Brasil wood is to be boiled in four litres of water for two hours; the decoction is then to be decanted and boiled down to two litres. As much red mordant must now be added as is necessary to form a fine red; and it is to be finally thickened with eight ounces of starch. The color will be more beautiful the older the decoction of Brasil wood is.

Instead of Brasil wood, wood of Japan, Saint Martha, or Nicaragua (peach wood), may be used, provided their color has been refined from the dun which they contain, by the usual process with milk.

*Topical yellow.*—This is prepared by boiling four pounds of Turkey or Avignon berries in twenty-four litres of water, which is boiled down to one-half. The clear liquor is drawn off, and a pound and a half of alum is dissolved in it. For the light yellows, it is thickened with gum; for the deep, with starch. This topical yellow does not resist soap. The following is equally fast and agreeable:—

In eight pints of water, boil four pounds of quercitron bark in powder, down to one-half of the bulk. Pass through the searce, thicken with three pounds of gum, and mix in gradually, sufficiency of solution of tin to render the color of a brilliant yellow. This yellow resists vegetable acids and soap very well. When placed on a blue ground, it forms a fine green; and it may be applied by the plate or the pencil.

The best solution of tin which can be employed for this topical yellow is that made with a mixture of three ounces of muriatic acid, four ounces of nitric, and four ounces of pure water. Two ounces of grain tin are to be dissolved bit by bit in this liquor. When the solution is completed, half an ounce of sugar of lead is to be added. The mixture must then be well stirred; left to settle, and decanted. Half an ounce of the clear solution is to be taken for every pint of the yellow bath. On mixing with the yellow bath a little of the annotto bath, we have orange yellows.

*Rust yellow.*—This is made with acetate of iron, or the black cask. It is thickened with gum for the light yellows, and with starch for the deeper shades. Rust yellow, when applied on blue, gives a deep green, which serves for the stems of certain flowers.

*Topical green.*—This preparation is formed by a mixture of topical blue and yellow, in which the yellow predominates considerably. The mixture must be made by little and little with the utmost care, so as to hit the wished-for shade.

*Topical aurora.*—A sufficient quantity of alum in solution must be added to the annotto bath; and the mixture is to be thickened with gum.

*Topical black.*—To twelve pints of the black cask, or of pyrolignite of iron, at 4° Baumé (for salts), add four ounces of Roman vitriol dissolved in water, and a sufficient quantity of decoction of galls to form a good black. Thicken with three pounds and a half of starch, which is to be gradually worked up with a portion of the liquor. Boil, withdraw from the fire, and keep stirring, till the liquor be cool; it must then be passed through a searce or a linen cloth.

*Another topical black.*—In twenty-four pints of water, boil two pounds of logwood, two pounds of sumach, and eight ounces of galls, till the liquor be reduced to half its volume. Add then a pint of the black cask (or pyrolignite of iron); boil away six pints; take off the clear bath, dissolve in it two ounces of Roman vitriol, and one ounce of sal-ammoniac; after which thicken with starch, and pass through a searce before making use of the composition.

*Topical violet and lilac.*—In thirty pints of water boil six pounds of logwood, ground or in chips, till ten pints be evaporated; decant the clear, and dissolve in it one ounce of alum for every pint of liquor. The deep violets are thickened with starch, and the light violets with gum, which is to be dissolved in the cold. This color changes readily, for which reason it should be prepared only as wanted; and be immediately put to use.

In the manufacture of printed calicoes, colors are obtained from madder, which result from the mixture of red and black. For mordants, mixtures in different proportions, of acetate of iron and acetate of alumina, are employed.

By printing on a mordant, composed of equal parts of oxidised acetate of iron (black bouillon) and acetate of alumina, both concentrated, a deep mordoré is obtained with madder. One part of acetate of iron, and two of acetate of alumina, afford a less sombre mordoré, inclining towards puce-colored. On augmenting the quantity of acetate of alumina, the shade approaches more and more to red; and, on introducing, at last, only one-twelfth of acetate of iron, an amaranth color is obtained. If, on the contrary, the proportion of acetate of iron be increased, browns are produced.

This color is that which requires most madder. It may be boiled longer than for the reds, but not so long as for the violets, because, as the portion of the coloring matter which is combined with the alumina does not stand a prolonged ebullition so well as that which has the oxide of iron for a mordant, the shade is degraded, and



CALICO PRINTING G.

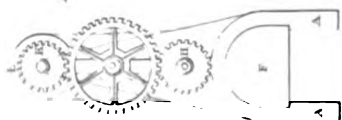


Fig. 7.



Fig. 8.

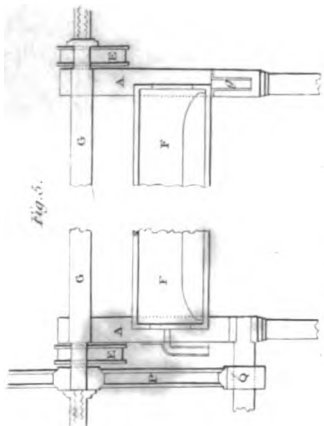
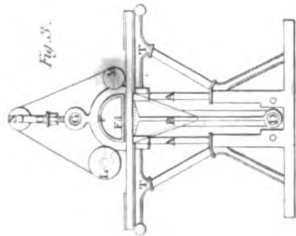


Fig. 10.



Fig. 11.

Fig. 1.

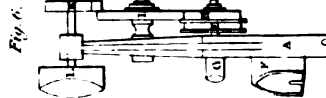
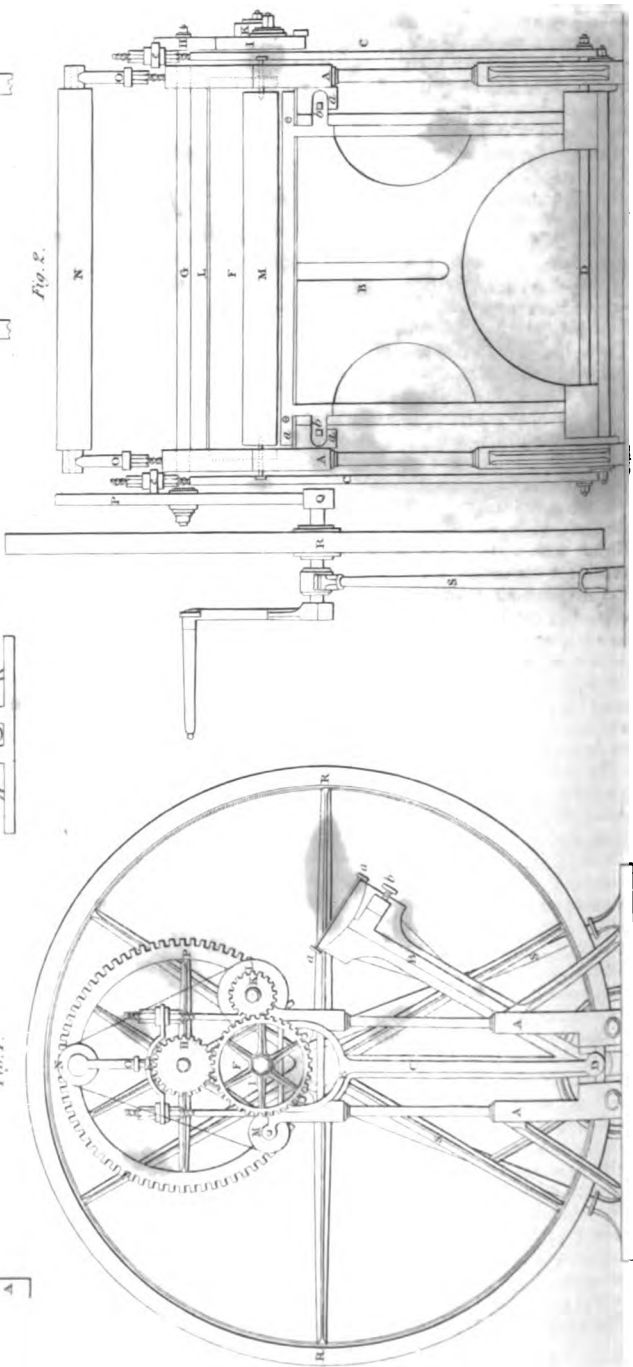


Fig. 12.

there is obtained only a poor and unequal color, instead of a substantial and well raised one. Great care should also be taken to put into the bath a sufficient quantity of madder, so as to saturate all the mordant; otherwise a uniform color can never be obtained, for the bath becomes exhausted, and some parts of the cloth would be saturated before other parts had been able to assume the proper shade. For conducting the operation properly, and for completely saturating the mordant, the maddering should be given at two times. The bath is scarcely suffered to boil the first time, and, from the hue that the cloth has taken, the quantity of madder to be employed at the second maddering may be determined. When the cloth is to have, besides the mordoré, fainter colors, they should not be printed on till after the first maddering, because the heat of the bath in the double maddering would degrade them. The mordorés have a more agreeable sue, when, previous to maddering, they have been dyed with nearly half the quantity of weld or quercitron which would have been used had they been dyed with these substances alone. The mordants for mordoré and puce afford, with both these substances, the shades of olive, bronze, terre d'Egypte, &c. In this case, it is sufficient for restoring the white, to pass through bran on their quitting the boiler, and to expose them for about eight days on the grass, lifting them once in this interval in order to wash and beetle them. The color has more lustre when, before drying the cloth, we pass it through water acidulated so slightly with sulphuric acid as to be hardly perceptible to the taste.

The following example of a spirit red directly applied in calico printing is valuable:—Prepare an aqua regia, by dissolving two ounces of sal ammoniac in one pound of nitrous acid, specific gravity 1.25. To this add two ounces of fine gran tin; decant it carefully off the sediment, and dilute it with one-fourth its weight of pure or distilled water.

To one gallon of water add one pound of cochineal, ground as fine as flour; boil half an hour; then add two ounces of finely pulverised gum dragon (tragacanth), and two ounces of cream of tartar; and stir the whole till it is dissolved. When the liquor is cool, add one measure of the preceding solution of tin to two of the cochineal liquor, and incorporate well by stirring. Apply this with the pencil or block; suffer it to remain on the cloth six or eight hours; then rinse off in spring water. This color will be a bright and beautiful scarlet.

Boil twelve pounds of Brasil chips during an hour, in as much water as will cover them. Draw off the decoction, pour on fresh water, and boil as before. Add the two liquors together, and evaporate slowly down to one gallon. To the decoction, while warm, add four ounces of sal ammoniac, and as much gum dragon or senegal as will thicken it for the work required. When cool, add one of the solutions of tin above described to four, six, or eight, of the Brasil liquor, according to the color wanted. Suffer it to remain for eighteen or twenty hours on the cloth; then rinse off in spring water as before. The color will be a pale and delicate pink. If

it be required deeper, the decoction must be made stronger, and used in the proportion of three or four to one of the solution of tin. Nicaragua or peach wood, though not so rich in coloring matter as Brasil, yields a color, however, which is, if possible, more delicate and beautiful.

A process in calico printing, of peculiar elegance, with an alkaline solution of alumina, was invented by James Thomson, esq., of Primrose Hill, near Clithero. Its effect was to produce a fast green, by the mixture of a yellow mordant with the common solution of indigo in caustic potash, through the intervention of orpiment. This, as is obvious, could not be done with any acid solution of alumina. Mr. Thomson first formed a solution of that earth in potash, mixed this with the solution of indigo, and applied the mixture, properly thickened, to the cloth. But as, in the ordinary dunging operation, the alkali would naturally wash away with it the greater part of the alumina, the goods before being dunged were passed through a solution of sal ammoniac. It is easy to perceive the rationale of what takes place. The potash on the cloth combines with the muriatic acid of the sal ammonia, and, as the two substances set free (the alumina and ammonia) have no tendency to combine, the former remains precipitated on the cloth at its points of application. It obtained currently, but very improperly, the name of Warwick's green, because Dr. Warwick made and sold the solution of aluminated potash to the printers.

Acetate of alumina is now most frequently made for the calico printers, by dissolving alum in a solution of crude acetate of lime (pyrolignite); a gallon of the acetate, of specific gravity 1.050, or 1.060, being used with two pounds and three quarters of alum. A sulphate of lime is formed, which precipitates, while an acetate of alumina mixed with some alum floats above. The specific gravity of this liquid is usually about 1.080. The acetate of alumina employed as a mordant for chintzes is still commonly made by the mutual decomposition of alum and acetate of lead. Fifteen parts of alum are equivalent to about twenty-four of acetate.

The maddering of printed goods requires pains and precautions, which long practice alone can teach. The causes which make their effects to vary are too numerous for us to point them all out here. The quantity of madder employed, the duration of the maddering, the manner of managing the fire, are, along with the dunging, the circumstances which have most influence; and they cannot be subjected to any rule, because they must differ more or less in almost every process.

It is plain that all these operations have for their objects, 1st, to remove the mordant uncombined with the cloth; 2dly, to fix the coloring matter; 3dly, to carry off, by the action of the air and bran, the dun coloring matter which is mixed with the madder, as well as the color which covers the parts of the cloth not impregnated with mordant.

The cloths intended for printing ought to be very carefully bleached. The more perfect the

white is, the more lustre do the colors take, and the more easy is the unmaddering. The fine whites on sale are not even sufficient; and it is right to give them at least one ley, one exposure on the grass, or one immersion in oxygenated muriatic acid, and to let them also soak some hours in water acidulated with sulphuric acid. Very frequently, several leys and several immersions must be given. Thus the dressing (paste) is completely removed, the remaining coloring matter of the cloth is destroyed, which, by fixing in a very durable manner, that of the madder, might render the unmaddering a difficult operation; and thus also the greater number of the stains formed during the maddering, to which the name of madder spots are given, are prevented.

These stains, almost indelible, very common on certain kinds of cotton cloth, and of a color perfectly similar to what madder gives to those parts of the cloth impregnated with oil, seem to arise from a combination with grease or oil, analogous to what takes place in the preparations of Turkey red. It is very probable that they are produced by the grease employed in the parou, or by the soap which must be employed in bleaching. The combination which in that case may be formed on the stuff, resists the subsequent operations well; and it will be seen, in the process for the Adrianople red, that the action of alkaline solutions, even pretty concentrated, is insufficient to destroy the combination of the oil with the cotton. A strong ley, run off very hot, does not afford a complete guarantee against these spots, although it may be the surest means of avoiding them. It would be of great consequence for calico printers to be able to exclude from weaving and bleaching both grease and soap.

The Adrianople red has a lustre, which it is difficult to imitate by all the processes hitherto described. It has, besides, the property of resisting more completely the action of the different re-agents, as alkalies, soap, alum, acids. Vogler acknowledges that by his numerous processes he has not been able to obtain a red possessing a durability equal to that of Adrianople, although he formed one much more permanent than the false Adrianople reds, which are often used for the siamoises and other red goods.

Aquafortis (dilute nitric acid) is, according to the same author, the surest and most expeditious means for distinguishing the true red of Adrianople from the spurious. It is sufficient to plunge a thread of the latter into it. It is soon seen to grow pale, and in less than a quarter of an hour it becomes white, whilst the true Adrianople red remains an hour without being affected, and it never loses the color entirely, which only turns orange.

The Adrianople red, which for a long time came to us through our Levant trade only, stimulated the industry of our artisans; but the attempts were for a long time fruitless, or success was confined to a small number of dyehouses. Abbé Mazeas published experiments which threw much light on this dye; and the government promulgated in 1765, from information that it had procured, an instruction under the title of Memoir,

containing the process for the incarnate cotton red dye of Adrianople on cotton yarn. The same description is found in the treatise of Le Pileur d'Apligny; but this process has not completely succeeded.

Three processes are employed for giving blue in the art of calico-printing. The first of these processes is used for dyeing cloth whose ground is to be blue or green; and, whenever they bear colors which are to be kept from varying in the vat, these are covered with the white reserve.

If the cloth is to retain a white ground, and bear blue figures, of one shade, or of several, the second of these processes is had recourse to. Sometimes one or two colors are joined to the blue thus made; but, in this case, they must be applied after the blue dyeing, because there is not a color which may not be either destroyed, or powerfully altered, in the operations which it requires.

Lastly, in other circumstances, a blue is to be put on cloth covered with a pattern, all of whose parts are already colored, and which leaves merely small spaces to color blue. For this purpose, the blue is used which is applied with the pencil (small brush). This blue of application is thickened with gum, and put upon the pencil. It may be printed on, by covering with canvas the frame which contains the thickened color, and removing the regenerated indigo with a scraper before applying the plate; but only small objects of a slightly intense blue, which rarely succeeds, can be thus applied.

Bancroft says, that he has substituted sugar for the sulphuret of arsenic with success; which would be advantageous, on account of the price and poisonous qualities of this substance. The experiment did not succeed with us. The blue of application has been attempted to be prepared by means of the oxide of tin; but the degree of concentration of the alkaline solution adequate to the solution of the oxide and the indigo has not been hitherto ascertained, so as to be susceptible of thickening with the gums. This point once determined, a pencil blue will be had, which will possess the very great advantage of not occasioning a bulky deposite, which always embarrasses the vessels where this blue is made in the ordinary processes, and which, however well washed, causes a considerable waste of the indigo.

In printing on cloth, ground indigo with oxide of tin, and passing the cloth through a solution of oxide of tin in potash, delft-ware blues may be made in a single vat. We have been able to make in this way only light blues. Were this process brought to the point of producing more substantial blues, it would afford great advantages.

The application of the chromate of lead on Turkey red cloth, forms a brilliant style of calico printing, now carried to high perfection at the establishment of Messrs. Monteith at Glasgow. Nitrate of lead is dissolved in liquid tartaric acid, of a specific gravity about 1.250: this solution is thickened with gum, and applied with the block to cloth previously dyed Turkey red. Whenever the paste is dried, the cloth is slowly passed through an aqueous solution, nearly sa-

tinued, of chloride of lime, kept at the temperature of about 100° in a stone trough. The tartaric acid, disengaging the chlorine, discharges the color of the Turkey red at the points of application; while the nitrate of lead, or rather perhaps the oxide of lead, remains attached to the cloth. This is immediately washed, and then passed through a solution of bichromate of potash, by means of the padding machine.

An orange color was a few years ago given to goods in calico printing, by means of the crystals of hydrosulphuret of soda and antimony, which are hence called orange crystals. But the use of the alkaline solution of sulphuret of antimony had been long known and practised by the Lancashire printers.

To produce violets on printed calicoes, the acetate of iron diluted with water is impressed, and they are maddered. This color is less easily degraded in the dyeing bath than the reds. It may also be kept boiling for a longer time, so as to raise the deep shades. The bath becomes very foul; the color comes out of it very dull, and assumes lustre only by exposure on the grass, and ebullition with bran water; it is even rare for the white to become beautiful again. But these inconveniences are obviated by dunging with a strong heat, which acts less upon this mordant than upon that employed for the reds.

For lilac, a mordant is printed on, composed of very dilute acetate of iron, mixed with a small quantity of acetate of alumina.

Few of the yellows produced from vegetable substances can acquire upon cotton permanence comparable to that of the colors producible from madder; and they never acquire this quality without losing their lustre. When a color rather fast than brilliant is wanted the cotton is colored with oxide of iron, by impregnating it with any of the various solutions of this metal. The processes employed for this dye are very numerous, and their shades may obviously be greatly multiplied, by varying the state of oxidation of the metal, or the nature of the acid which holds it in solution; as also by slight changes in the proportions of the materials, and in the manipulations.

In order to obtain a deep color, Chaptal treads the cotton in a solution of sulphate of iron, marking from 12° to 15° Baumé. He squeezes it very slightly but equably. As soon as the whole portion (lot) is dipped, it is repressed, hank by hank, through the same solution, and immediately afterwards through a solution of potash, marking the same number of degrees. The color of the cotton becomes of a dirty blue-green, which changes in a few minutes to an agreeable golden yellow. At each dipping the vessel into which the cottons are plunged must be emptied, in order that the color may be equal and uniform.

For a pale and very soft yellow, he treads the cotton in a solution of sulphate of iron, marking three degrees, and represses it as in the preceding process. On the other hand, he prepares a liquor with solution of potash, marking from two to three degrees, to which he adds solution of alum till he observes that the floccs are no longer dissolved. He impregnates the cotton

with this liquid, and renews it for each dip. The cotton is dyed of a very agreeable yellow. When the colors are not sufficiently deep, the cotton may be repressed through stronger solutions.

Chaptal recommends, for making the colors evenly, to pass at once no more than one-fourth kilogramme of cotton, to employ weak solutions of sulphate of iron, to dip the cotton first in a solution of potash, then in one of sulphate of iron, repeating these alternate dips as often as shall be requisite to arrive at the desired shade, and to use the greatest care in impregnating and squeezing the cotton equably.

A fresh-butter yellow is produced, by passing the cotton through slightly oxidised acetate of iron, mixed with nitrate of iron, which may be made to incline more to red, the greater the proportion of the latter salt.

With nitrate of iron alone, diluted with water, a pretty clear yellow may be had, which rises quickly. If the cotton be impregnated with nitrate of iron little diluted, allowed to dry, and then washed, it retains a very deep tint, similar to that of rust.

The rust-yellow, which is printed on cloth, is made with two parts of sulphate of iron, and one part of acetate of lead. By mixing with this, different proportions of highly oxidised oxide of iron, shades bordering on red may be procured.

Cotton dyed by these processes takes very different colors in the dye-baths. That which received a faint yellow color by the process of Chaptal, becomes of a walnut hue in the decoction of galls. When the color is deeper it becomes mouse-gray; with tan, or quercitron, it affords a yellow. When passed through a decoction of equal parts of nut-galls, sumach, logwood, and weld, the cotton becomes of a dirty gray-white. When dried, and passed through a strong solution of sulphate of iron, it assumes the bluish-gray color, which is called *œil de roi*.

Bancroft describes a topical color (*couleur d'application*), which is obtained from quercitron. A strong decoction of quercitron is made, filtered, and evaporated at a gentle heat, and when it is reduced to less than one-half, it is allowed to cool to the temperature of the living body. After this, one-fourth of acetate of alumina is mixed with this liquid. The mixture is thickened with as much gum as is necessary to prevent its running during the impression, but not so much as to obstruct its penetrating the stuff. The color obtained by this application has neither as much intensity, nor as much permanence, as that procured by previously impregnating the stuff with the mordant. Both qualities may, however, be increased by a mixture of nitrate of copper and nitrate of lime.

Quercitron ought undoubtedly to be considered as a very useful substance in dyeing; yet the attempts which we know to have been made, with the precautions prescribed by Bancroft, especially in reference to the temperature of the bath, seem to us to prove that the color derived from it is inferior in permanence to that producible from weld. A purer and more lively color may be obtained from quercitron, by adopting

the process which Chaptal has given for fustic (yellow wood).

For dyeing cotton yellow, preparatory to printing, the first thing is to scour it in a bath prepared with a lixivium of the ashes of green wood, then to wash and dry it. It is alumed with the fourth of its weight of alum. After twenty-four hours it is taken out of the aluming and dried, without washing. A weld bath is thereafter prepared, at the rate of one part and a quarter of weld for one of cotton. In this the cotton is dyed, by turning it round the sticks, and working it with the hands, till it has acquired the wished-for shade. It is taken out of this bath to be macerated for an hour and a half in a solution of sulphate of copper or blue vitriol, in the proportion of one-fourth of this salt to one part of cotton. It is next thrown, without washing it, into a boiling solution of white soap, made in the same proportions. After being well stirred, it is to be boiled for nearly an hour, after which it must be well washed and dried.

If a deeper yellow, bordering on jonquille, be wanted, the cotton is not passed through the aluming, but two parts and a half of weld are employed to one of cotton, with the addition of a little verdigris dissolved in a portion of the bath. The cotton is plunged into it, and worked, till it has taken a uniform color. It is lifted out of the bath that a little soda ley may be poured in, when it is again immersed and turned through the bath for a full quarter of an hour. It is then withdrawn, wrung, and dried.

Lemon yellow is made by the same process, except that only one part of weld is used (for one of cotton), while the quantity of verdigris can be diminished in proportion, or even entirely omitted, and aluming put in its place. Thus the shades of yellow may be varied in many ways. The operations on linen yarn are the same.

For the yellow colors, on printed cotton goods, these are impregnated, by means of engraved plates, with the mordant described in treating of madder, formed by the mixture of acetate of lead and alum: the yellow color induced on the parts not impregnated with the acetate of alumina is to be afterwards destroyed by the action of bran, and exposure on the grass. The same mordant may be successfully employed for cotton and linen which is to be dyed yellow.

In order to obtain from weld the whole color that it can yield, it must be boiled for three-quarters of an hour; the bundles of weld are now taken out of the bath, after which the cloths are passed through it, at a temperature a little below ebullition. They should not remain in it more than twenty minutes.

When the same piece of cloth is to exhibit the colors produced by both madder and weld, it is necessary to begin with the madding, and not to print on the mordant intended for the weld till the operations of the madder are finished. This rule is founded on the property which madder possesses of fixing itself in the room of the yellow of weld; so that if the madding be long continued, after dyeing with weld, the color of the latter entirely disappears. Weld, on the contrary, does not affect the color produced by

madder, provided the mordant has been saturated with the latter, for otherwise a mixed color would be produced.

The operations required for restoring the white are much longer, and demand much nicer management, after welding than after madding. See DYEING, par. 203.

By the following method we procure red colors, beautiful and permanent, without employing ley, oils, or galls:—Lime slaked in the air is to be dissolved in cold acetic acid. The solution marks from 5° to 6°; and it is reduced to 2° by the addition of water. Equal parts of this solution and acetate of alumina are mixed. The latter is prepared by pouring five kilogrammes of acetate of lead into a solution of twenty kilogrammes of alum for 175 kilogrammes of water. The above mixture is made tepid, and the cottons, merely scoured with care, are passed through it. They are dried, thoroughly washed, dried and madded with three-fourths of a kilogramme of madder for one kilogramme of cotton. They are brightened with ley and soap, then passed through a solution of tin, and revived with soap alone, in the proportion of twelve kilogrammes of soap for 100 kilogrammes of cotton.

Very durable reds may be had by passing the cotton through this mordant, after having submitted it to oiling without galling. They are even very deep. But on passing the cotton which has received a single oil and four leys through a mixture of acetate of alumina, with one-fourth, one-twelfth, or one-eighteenth of lime, various very lively shades are obtained.

For making a dead red without lustre, termed in some places burned red, or Indian red, on account of its resemblance to that of Indian handkerchiefs, the cotton is scoured, boiled for half an hour in lime water, passed through an oil mixed with some intestinal liquor, and through three leys. It is washed well and turned through a mordant composed of a tepid solution of twelve kilogrammes and a half of alum, to which four kilogrammes of acetate of lead have been added; and a moment afterwards, half a kilogramme of soda in powder, and 0.244 kilogrammes of sal-ammoniac. It is washed with care, and madded with its own weight of madder. If the color be poor, it is passed once more through an oil, two leys, the same mordant, and a madding. It may be brightened with soda and soap. The lime alone produces the difference between this color and the preceding. It renders the colors more permanent, but duller.

The durable rose (color) is produced by taking cotton passed through the oils, and which has received more numerous but weaker leys. It is galled with a ley of sumach (lessive de sumac?) in which two kilogrammes and a half of gallnuts have been boiled; and alumed with seventeen kilogrammes and a half of alum. It is now washed, dyed with madder of the best quality, the madder bath being whitened (blanchi) with two kilogrammes of the oxide of tin, that precipitates from the solution of this metal in nitric acid. It is brightened with weak ley and soap, dried, and passed through a liquor formed of a solution of tin (in nitric acid at 32°, diluted with

an equal volume of water), reduced to 4°. It is washed and brightened in a solution of fifteen kilogrammes of soap, till the color be rosed in perfection.

On passing the cotton through soap of wool made with soda, taking the same pains as with the soapy liquor prepared for the red, and using very weak leys in the interval, then washing the cotton, and treating it by the same process as for dyeing wool scarlet, it assumes a scarlet tint, paler than that of wool, but pretty brilliant.

Cotton dyed red may, moreover, be made to pass through all the shades, down to the palest orange. For this purpose, pure nitric acid is diluted with two-fifths (three-fifths?) of water; chips of tin are oxidised in it till the liquor grows opal, and the solution is employed at different strengths, from 2° to 20°.

Poerner made a great many researches on the methods which may be employed to dye cotton by means of brasil, employing different mordants, as alum, solution of tin, sal ammoniac, potash, &c., in the bath, or in the preparation of the stuff; but he did not obtain colors which could resist the action of soap, although some of them stood pretty well the action of the air and washing with water. He recommends us to dry in the shade the cottons which have received these colors.

To Brown, who is engaged with much zeal in the arts, we are indebted for a process which is used for a crimson on cotton in some manufactures.

A solution of tin is prepared in the following proportions:—Nitric acid four parts; muriatic acid two parts; tin one part; water two parts. The liquids are to be mixed, and the tin dissolved in them, by adding it in small bits at a time.

As the best colors that can be given to linen and cotton are derived from madder, attention must be paid to the methods described, in treating of madder, for rendering this dye more durable, and its color may be deepened by different black baths. For some hazels and snuff colors, a browning is given, after the welding and the madder bath, with soot, to which gall nuts and fustic are joined. Soot is sometimes mixed with this bath, and a browning is moreover given with solution of sulphate of iron.

Walnut peels are occasionally substituted for solutions of iron in browning colors. They have a great advantage for the wools intended for (tapisseries) tapestry. The color does not become yellow by long exposure to the air, as happens to the brownings from iron; but it keeps long without alteration. It has indeed a dull tone, suitable for shadows, and for representing the flesh in old figures, which would produce merely gloomy colors, without lustre, on cloths. The goodness of this color, however, and its cheapness, ought to extend its use for the sombre colors which are sometimes in fashion, at least on common stuffs.

A great number of shades are made at the Gobelins by means of this browning. To procure an assortment of them, a bouillon is first given to the woollen yarns with tartar and alum of different degrees of strength, according to the

shades required; they are then successively dyed red, yellow, or some other color, recurring to the bath from which most effect is wished to be obtained. When the color is found to be of the desired shade, it is passed, for a shorter or longer time, through the bath of walnut peels, of a strength adjusted to its purpose. This browning is likewise had recourse to for silk; but the bath must be hardly tepid, in order to avoid the inequalities to which it is so liable.

For the different shades of marrone the cotton is galled, passed with the ordinary manipulation through water, into which a greater or less quantity of the black cask (tonne au noir) has been poured. It is next worked in a bath in which verdigris has been dissolved; and a welding is given it. It is dyed in a bath of fustic, to which a solution of soda and alum is sometimes added. When the cotton which has received these preparations has been well washed, a good madding is given it. It is then passed through a weak solution of sulphate of copper, and lastly through soap water.

The cinnamon and mordoré colors are given to linen and cotton by commencing the dyeing with verdigris and weld; they are next passed through a solution of sulphate of iron, which is called the security bath (bain d'assurance), and they are wrung out and dried. When dry they are galled in the proportion of 122 grammes of gall-nuts per kilogramme; they are once more dried, alumed as for red, and maddered. When they are dyed and washed, they are passed through very hot soap water, in which they are turned round the sticks till they are sufficiently brightened. Decoction of fustic is sometimes added to the aluming.

By taking cotton which had received the requisite preparations for the Adrianople red, and had been galled, then passing it through nitrate of iron, galling it anew, and aluming, Chaptal obtained a pretty nacaret. He prepares the nitrate of iron with the aquafortis of commerce, diluted with half its weight of water, into which he plunges fragments of iron, which he removes whenever he perceives the solution slackening. The liquor is now of a yellowish red, strongly acid, and marks from 40° to 50° on the aréomètre of Baumé. See DYEING, 180.

If after galling the cotton that has passed through the oils it is alumed in a bath, to which one-eighth of this solution of iron, for one of cotton, is added, the cotton comes out black, and takes a violet sloe color by the madding and brightening.

James Thomson, esq., of Primrose Hill, F.R.S. obtained, in the years 1813 and 1815, two patents for certain improvements in calico printing. His processes, which are very elegant, have since been extensively and advantageously employed. The following is an outline of his specifications. That for 1813 is thus stated:—

First, Mix or combine with the acid called oxymuriatic acid (or dephlogisticated acid of sea salt) and water, some of the alkaline salts or earths hereinafter-named, which shall weaken or suspend the power of the said acid in such proportion that it shall not, in such mixed or combined state, of itself, and without any farther operation, be able



to remove the Turkey red color from the cloth, or materially to impair it, within the moderate space of time taken up in the performance of the process hereinafter described.

Secondly, Print, stamp, pencil, or otherwise apply to those parts of the said cloth, which are intended to be either wholly, or in a greater or less degree, deprived of their red color, some other acid, or metallic oxide, or calx, which has a greater affinity or attraction for the alkaline salt or earth with which the oxymuriatic acid is mixed or combined, than that acid itself possesses: and if any one of the stronger or more powerful acids be employed, which is either of a corrosive nature and cannot be safely used, or of a volatile nature and cannot be used conveniently, such acid must be combined with alkalies, earths, metals, or metallic oxides or calces, so as to form neutral salts, acid salts, or metallic salts, which shall not be too corrosive or too volatile; and such alkalies, earths, metals, or metallic oxides, or calces only, must be employed, as have a weaker affinity or attraction for the same acid than that acid has for the alkaline salt or earth with which the oxymuriatic acid has been mixed or combined.

Thirdly, After the said acid, oxides, neutral salts, acid salts, or metallic salts, so directed to be printed, stamped, pencilled, or otherwise applied to the cloth as aforesaid, are sufficiently dry, immerse the cloth in the solution of the said oxymuriatic acid, so mixed or combined with some of the alkaline salts or earths hereinafter named as aforesaid. When the acid or oxide, either in its simple or combined state, has been applied to parts of the cloth, it immediately seizes upon and combines with the alkaline salt or earth with which the oxymuriatic acid has been mixed or combined, and disengages that acid, which almost instantaneously deprives of their color those parts of the cloth to which the said acids or oxides, in their simple or combined state, have been so printed, stamped, pencilled, or otherwise applied as aforesaid.

Lastly, Wash or otherwise remove all the said acids, oxides, or salts, by the usual processes. For the more fully explaining and illustrating the invention herein before described, I add the following remarks:—The alkaline salts or earths which I mix or combine with the oxymuriatic acid, in order to suspend or prevent its action on those parts of the red cloth which are intended to retain their color, are the alkaline salts of potassa and soda, or the calcareous, magnesian, barytic, or strontitic earths, of which I prefer the calcareous earth.

The acids which I apply to the parts intended to be made white, or to those places on the cloth intended to be deprived of their red color, in a greater or less degree, are any of the vegetable, mineral, or animal acids, which have a stronger attraction for the alkaline salt or earth with which the oxymuriatic acid has been mixed or combined, than that acid itself has; such, for instance, are the citric, oxalic, tartaric, malic, benzoic, sulphuric, sulphurous, phosphoric, fluoric, boracic, nitric, muriatic, arsenic, tungstic, succinic, and carbonic acids.

The stronger acids, or such as might corrode

the cloth, I saturate more or less with some alkaline salt, earth, or metallic oxide or calx, for which they have a weaker affinity or attraction than they have for the alkali or earth with which I have combined the oxymuriatic acid: for instance, I unite the sulphuric acid with potassa, so as to form the acid sulphate of potassa (or acid vitriolated tartar), or with aluminous earth, to form alum. The muriatic acid I combine with tin, or copper, or zinc, forming muriate of tin, muriate of copper, or muriate of zinc. In like manner, the nitric acid may be combined with the aluminous earth, or with the volatile alkali, or with the metals, or oxides of copper, or zinc, or iron, or mercury; and I take care, when I use acidulous compounds of such corrosive acids, not to suffer the acid so far to predominate as to render the compound injurious. In like manner I combine the volatile acids, or such as might evaporate too speedily, with some alkaline salt or earth, or metallic oxide or calx, for which they have a weaker affinity or attraction than they have for the alkali or earth with which I have combined the oxymuriatic acid: for instance, I combine the acetic acid with the earth of alum, so as to form acetate of alumina,—or with copper, forming acetate of copper,—or with zinc, forming acetate of zinc. The carbonic acid may also be fixed and combined with an alkali, as with soda, for example, forming carbonate of soda, which may be used, though with less advantage than the preceding combinations. Those acids which are not corrosive nor volatile, and which consequently are used with most advantage in their simple or combined state, may, however, be united like the preceding to the alkalies, earths, metals, or metallic oxides or calces, for which they have a weaker affinity or attraction than they have for the alkali or earth with which the oxymuriatic acid has been united. Thus the tartaric acid may be combined with potassa, to form cream of tartar,—and the oxalic acid with potassa, to form salt of sorrel,—and these two salts may be employed in the process, though it is not necessary so to combine the two acids; but, on the contrary, the acids may be used alone.

The combinations which I prefer, as uniting the greatest number of advantages upon the whole, are, the supersulphate of potassa (or acid vitriolated tartar), the sulphate of copper or blue vitriol, the muriate of tin or sal jovis, the nitrate of copper, and the muriate of copper. But I prefer to any single combination a mixture of the supersulphate of potassa, with the tartaric or citric acids.

Lastly, I employ, uncombined, such metallic oxides or calces as approach in their properties to the nature of acids, and are capable of combining either with the alkaline salts of potassa or soda, or with the calcareous, magnesian, or strontitic earths, or of disengaging them, or any of them, from their combination with oxymuriatic acid: such, for instance, is the oxide of arsenic, or common white arsenic, and the oxides of tin and tungsten.

It is evident, from what I have set forth in the preceding part of this specification, that this process admits of great variety in its application, according to the combinations I make use of;

since not only the various acids, oxides, and salts I have enumerated, may be employed, but also various mixtures of them, and in various proportions; but I prefer and generally use the following process:—

First, I take one gallon of good vinegar, or rectified pyrolignous acid, which I thicken with starch or flour in the way practised by calico printers, in preparing the mordants or colors for printing. Whilst boiling hot I add to it five pounds of crystallised tartaric acid, and incorporate the whole very well by stirring.

Or, I take one gallon of strong concentrated lime juice or lemon juice, or one gallon of water, in which I have dissolved two pounds and a half of crystallised citric acid, which I thicken with starch or flour in the manner directed above, and to which, whilst hot, I add two pounds of supersulphate of potassa, and incorporate the whole very well by stirring. I prefer starch to any other thickening, though others may be used with more or less advantage.

Secondly, the paste so prepared I print, stamp, pencil, or otherwise apply to the cloth previously dyed turkey red, in the mode and with the precautions generally used in the printing or stamping of linens or cottons.

Thirdly, I prepare a solution of oxymuriate of lime, either by dissolving the dry oxymuriate of lime (commonly called bleaching powder, or bleaching salts) in water, or by passing the oxymuriatic acid gas into a vat, vessel, or cistern, in which, by agitation or otherwise, I keep suspended such quantity of quicklime as will more than saturate fully and completely the said oxymuriatic acid gas. In either way, I obtain a solution of oxymuriate of lime, with excess of lime. That which I use and prefer is of the specific gravity 1050, and I seldom employ it lower than 1030 (water being considered as 1000). The vat, vessel, or cistern, which contains the solution of oxymuriate of lime, in which I immerse the cloths, may be of any size or form best adapted to the purpose or situation. I use and prefer vessels of stone of from six to eight feet deep, six to seven feet long, and three and a half to four feet broad; but larger or smaller vessels will answer very well.

Fourthly, When the cloths are ready for immersion, which they are as soon as the paste is dry, I hook them on a frame, such as is used in dyeing indigo or China blues, commonly called a dipping frame, on which the cloth should be so disposed that no two folds can touch each other. I then plunge the frame with the cloth so attached into the vat containing the solution of oxymuriate of lime, and keep it gently in motion during the time of immersion, which should not be prolonged more than ten minutes, and which rarely need exceed five minutes. The object being either wholly or partially to remove the Turkey red dye from certain parts or places, as soon as that is done the cloth should be withdrawn from the solution of the oxymuriate of lime, and plunged or nosed in clean water. I practise and approve the aforesaid plan of immersion; but any other plan or plans by which the cloth can be exposed a greater or less time to the action of the oxymuriate of lime, without bringing one part of the

said cloth into contact with another, will answer very well.

Lastly, After having, as before directed, rinsed or washed the cloths in clean water, I free them from all remains of the different agents or substances employed, by the ordinary means of washing, branning, or soaping, as practised by calico printers; and if those parts of the cloth that are intended to be made white should still retain any red, or other tinge or stain injurious to the effect, in order to render the white complete I clear it by the usual process of exposure to the air, or by passing the cloth through hot water, to which I have added as much of the solution of oxymuriate of lime as will remove the said stains or tinge, without material injury to those parts from which the red dye is not intended to be removed.

I then proceed, if other colors are to be applied to finish the cloths, by the ordinary and well known methods of calico printers; but these not being necessarily connected with, nor forming any part of the peculiar process or invention herein intended to be described, I purposely make no mention of here.

The above particulars and examples are given for the more full explanation of the said invention, and the manner in which the same is to be performed. But the invention, whereof I claim the sole and exclusive use, consists in printing, stamping, pencilling, or otherwise applying to those parts of the cloth which are intended to be either wholly, or in a greater or less degree, deprived of their red color, an acid, oxide, neutral salt, acid salt, or metallic salt, such as is herein before for that purpose directed, and immersing the whole cloth in such mixture or combination of oxymuriatic acid and water, with some of the alkaline salts or earths, as is herein directed for that purpose.

Mr. Thomson's patent for 1815 is specified as follows:—The ordinary practice of calico printers is to apply, with the block or pencil, what are termed after-colors, to certain spaces, originally left in their patterns, and intended to receive the said after-colors; or to certain spaces on the cloth, from which parts of the original pattern have been discharged, in order to admit, by a subsequent operation, the application of the said after-colors. Now the object of my invention is, by one application of the block, cylinder, roller, plate, pencil, or other mode, to remove parts of the original pattern or color from the cloth, and at the same time to deposit a metallic oxide, or earthy base, which shall of itself be a color, or shall serve as a mordant to some color to be produced, as hereinafter described.

First, mix or combine with the acid called oxymuriatic acid (or dephlogisticated acid of sea salt) and water, the alkaline salts of potash or soda, or, which is still better, calcareous earth or quicklime, in such proportion as will weaken or suspend the power of the said acid, so that it shall not in such mixed or combined state, of itself, and without any further operation, be able to remove, or materially to improve the colors, within the moderate space of time taken up in the performance of the process.

Secondly, Print, stamp, pencil, or otherwise

apply to those parts of the cloth which are intended to be deprived of one color and to receive another, a solution of some earthy or metallic salt; the acid of which, having a greater affinity or attraction for the alkaline salt or earth with which the oxymuriatic acid is mixed or combined than that acid itself possesses, will disengage it, and the metallic or earthy base of which, being deposited in the cloth, will either of itself be a color, or serve as a mordant to some other color, to be produced as hereinafter described.

Thirdly, After the metallic or earthy solution aforesaid has been printed, stamped, pencilled, or otherwise applied to the cloth, as before directed, and is sufficiently dry, immerse the cloth in the solution of oxymuriatic acid, combined with the alkaline salt of potash or soda, or, which I greatly prefer, with calcareous earth or lime, when the acid of the metallic or earthy solution which has been applied to parts of the cloth will immediately seize upon and combine with the alkaline salt or earth with which the oxymuriatic acid has been mixed or combined, and disengage that acid which will almost instantaneously deprive of their color those parts of the cloth to which the said earthy or metallic salt has been applied.

Fourthly, Wash or otherwise remove the said acids or salts by the usual processes, and when the earthy or metallic base, deposited in the cloth, is intended to receive another color, proceed to raise it by the usual operations of dyeing, as will be further illustrated in the examples hereafter given of particular applications of this invention. The earthy solutions which I apply to the parts intended to be deprived of their color, and to receive another, are the solutions of alumina, or earth of alum in acids; such, for example, as the sulphate of alumina, or common alum, the acetate of alumina, or the nitrate or muriate of alumina. The metallic solutions which I employ are, the sulphate of iron or coppers; the nitrate, or muriate, or acetate of iron; the muriate of tin, or nitro-muriate of tin; the sulphate of copper or blue vitriol, or the nitrate, muriate, or acetate of copper. All acids that form soluble compounds with the before-named metals, or the earth of alum, may be employed; but those only which form the most soluble compounds, such, for example, as those enumerated above, can be employed with advantage. For the more full and complete understanding of the principle laid down in the preceding part of this specification, I subjoin the following practical illustration of its application to various kinds of work. If I desire to have a yellow figure or stripe on the cloth, upon which a madder-red ground or pattern has been printed, after having, by the ordinary processes of calico printing, produced the red ground or pattern, I first print, stamp, pencil, or otherwise apply to those parts intended to be yellow, a strong aluminous mordant, composed of three pounds of sugar of lead, and six pounds of alum, dissolved in a gallon of water, and thickened with a due proportion of calcined starch, in the manner usually practised by calico printers.

Secondly, I prepare a solution of oxymuriate of lime, either by dissolving the dry oxymuriate

of lime (commonly called bleaching powder, or bleaching salts) in water, or by passing the oxymuriatic gas into a vat, vessel, or cistern, in which, by agitation or otherwise, I keep suspended such a quantity of quicklime as will more than saturate fully and completely the said oxymuriatic gas. In either way I obtain a solution of oxymuriate of lime, with excess of lime. That which I use and prefer is of the specific gravity 1050, and I seldom employ it lower than 1030 (water being considered as 1000). The vat, vessel, or cistern, which contains the solution of oxymuriate of lime in which I immerse the cloth, may be of any size or form best adapted to the purpose or situation. I use and prefer vessels of stone, of from six to eight feet deep, six to seven feet long, and three and a half to four feet broad; but larger or smaller vessels will answer very well.

Thirdly, When the cloth is ready for immersion, which it is as soon as the paste is dry, I hook it on a frame, such as is used in dyeing indigo or China blues, commonly called a dipping frame, on which the cloth should be so disposed that no two folds can touch each other. I then plunge the frame, with the cloth so attached, into the vat containing the solution of oxymuriate of lime, and keep it gently in motion during the time of immersion, which rarely need exceed five minutes. The object being to remove the red dye from certain parts or places, as soon as that is done the cloth should be withdrawn from the solution of the oxymuriate of lime, and plunged into, or rinsed in cold water. I practise and approve the aforesaid plan of immersion; but any other plan, or plans, by which the cloth can be exposed a greater or less time to the action of the oxymuriate of lime, without bringing one part of the said cloth into contact with another, will answer very well.

Lastly, After having, as before directed, rinsed or washed the cloth in clean water, I free it from all superfluous remains of the different substances employed, by the ordinary means of washing, dunging, and cleaning, as practised by calico printers; after which I dye the cloth and raise the yellow in the usual way, with quercitron bark, or any other yellow dye.

If, instead of yellow, it is proposed to have a buff pattern or figure, I add to the aluminous mordant, prepared and thickened as above, one-fourth or one-sixth, or some intermediate proportion, of a solution of nitrate of iron, and proceed to print and immerse in oxymuriate of lime as in the former case.

The red dye will be removed as before, and its place be occupied by a buff. If the buff be raised in quercitron bark, an olive will be obtained. By printing at separate times, and on different parts of the cloth, each of the above-mentioned mordants, both yellow and olive figures on a red ground may be obtained. Similar effects, with trifling variations, take place, when, instead of red grounds, purple or chocolate grounds are employed; but it must be observed, that these colors being produced from mordants, consisting wholly, or in part, of solutions of iron, and the oxide of that metal not being removeable by the process detailed in this

specification, the after colors produced will be modified more or less by the said oxide of iron. The foregoing examples are given for the more full explanation of the said invention, and the manner in which the same is to be performed; but the invention, whereof I claim the sole and exclusive use, consists in printing, stamping, pencilling, or otherwise applying to cloth, previously printed and dyed, or dyed any other color than turkey red, any of the earthy or metallic solutions herein before for that purpose directed, and immersing the whole cloth in such mixture or combination of oxymuriatic acid and water, with some of the alkaline salts or earths, as is herein directed for that purpose, so as to remove the color or pattern from the part so printed, stamped, pencilled, or receiving such application, and, by the same process, fix on such parts either a new color or a mordant for a new color.

In our treatise on the manufacture of cotton it was found necessary to describe the admirable printing apparatus employed at the Bandana works in Glasgow, and we now propose to furnish our readers with an account of Mr. Maudslay's press for a nearly similar purpose. Figs. 1. and 2. plate PRINTING, CALICO, represent an end and front view of the machine. A, A, are frames of cast-iron, wood, or other strong materials. B, B, are swinging frames of iron or wood; the upper surfaces of which are made flat, to receive engraved copper plates, fastened on and regulated by screws at *a a*. The screws at *b b* are to stop and regulate the swinging frames against pieces which project on the insides of the frames A, A, at *d d*. C, C, are slings or connecting rods of iron or other metal which have round holes at D, in the bottom end, to receive the ends of the strong bolt D, which is connected to the frame B, B. The upper part of the connecting rods C are forked, to pass the pivots of wheels, &c., on the ends of the frames A, A, and are screwed in the usual way, have two metal nuts to each, to keep down and regulate the cross pieces of iron or other metal *e*, which fit on and into the eccentric wheels or cranks E. These are made of iron or other metal, for the purpose of lifting the swinging frame B, by means of the connecting rods C, C, and pressing the copper plates forcibly against the under part of the cylinder or press-head F, which is better seen in figs. 3 or 5. Through the eccentric wheels, &c., are made square or other formed holes, which are well fitted on the spindle G, close on the outsides or insides of the frames A, A; on the outsides of which are fitted the toothed wheel H, which works into and turns the wheel I, which is twice the diameter of H, and has on the rim a piece of metal of the proper curve with three whole teeth and one half tooth, which in their revolution fall into the teeth of the wheel R, fixed on the axis of the roller L; which wheel will be regulated as to its number of teeth by the circumference of the roller L, which must be twice or three times the

length of the engravings on the plate to be printed from; if twice it must have eight teeth, if three times twelve teeth; or in that proportion. The half of every fourth tooth must be taken away to let the tooth of the segment on I pass; that it may strike fairly on the pitch line of the next tooth. The small roller M may be used or not as occasion may require, as it is only to ease the motion of the blanket which passes over the roller N, which is to tighten the blanket by means of the screws and sockets O. At the opposite end of the spindle G is well fitted a large wheel P, which is turned by the pinion Q on the spindle of the fly-wheel R, and supported by the frame S, of iron or wood. This spindle may be turned by hand or by any other power given. The wheel and pinion may be varied to any power, by altering the sizes of them in the usual way. The plates may be cleaned by a scraper or doctor.

Fig. 3 is a transverse section of the machine, showing a different mode of using it. The frame A A is the same as in fig. 1 and 2, with the addition of two arms and brackets T, T, which support a frame of iron or wood, on which are fixed one, two, or more, copper plates. To print several colors they move to stops, and are regulated as in figs. 1 and 2. The cylinder E is made hollow, for the purpose of admitting steam, which will heat it to any temperature, to dry the color as quick as printed. The manner of letting in the steam is described in fig. 5. The lifting frame B acts the same as in figs. 1 and 2. Fig. 4 is a lifting frame, which has a cylinder similar to F, and may be used in the place of B, which makes it a hot-press for various purposes, by letting steam into the bottom as well as the top cylinder; and in case the color should dry in the plates, owing to the heat, cold water may be made to pass through the cylinder, which will always keep it cool. Fig. 5 is a longitudinal section of the cylinder, eccentric wheel, &c., with the manner of admitting steam by a small pipe at *f*, which may be connected with the boiler of a steam-engine, or a small boiler on purpose, which will serve one, two, or more presses, each having stop-cocks at convenient places. *g* is a pipe in the bottom of the cylinder to let out the condensed water.

Figs. 6 and 7 represent a side view of the upper part of the machine, with the roller L placed above the cylinder, by which means the blanket is closer, and may if required receive more heat from the cylinder. The roller is moved by the same wheels as in figs. 1 and 2, only differently placed.

We must not close our account of the theory and practice of calico printing without adverting to the great use we have made of Dr. Ure's edition of Berthollet's Elements of the Art of Dyeing, which is decidedly the best work on the subject that has yet appeared.

**PRIOLO**, or **PRIOLUS** (Benjamin), an eminent Italian historian, born in Venice, in 1602, and descended from the illustrious family of Prioli, some of whom had been doges of Venice. He studied at Orthez, Montauban, and at last at Leyden, under Heinsius and Vossius. He went to Paris to visit Grotius, and studied Aristotle at Padua, under Cremonius and Licetus. He became a confidant of the duke of Rohan; afterwards married and retired to Geneva; became intimate with the duke of Longueville, cardinal Chigi (afterwards Alexander VII.), and cardinal F. Barberini, and became a Roman Catholic. The civil war breaking out in France, he joined the malecontents, and his estate was confiscated. He then retired to Flanders, where he wrote his History of France, in Latin. He died at Lyons, in 1667, aged sixty-five.

**PRIOR** (Matthew), an eminent English poet, born in London in 1664. His father dying while he was very young, an uncle, a vintner, having given him some education at Westminster school, took him home to bring him up to his own trade. However, at his leisure hours, he prosecuted his study of the classics, and especially of his favorite Horace. This introduced him to some polite company, who frequented his uncle's house; among whom the earl of Dorset took particular notice of him, and procured him to be sent to St. John's College in Cambridge, where, in 1680, he took the degree of A. B. and afterwards became fellow of that college. Upon the revolution, Mr. Prior was brought to court by the earl of Dorset; and in 1690 he was made secretary to the earl of Berkeley, plenipotentiary at the Hague; as he was afterwards to the ambassador and the plenipotentiaries at the treaty of Ryswick in 1697; and in 1698 to the earl of Portland, ambassador to the court of France. He was in 1697 made secretary of state for Ireland; and in 1700 was appointed one of the lords commissioners of trade and plantations. In 1710 he was supposed to have had a share in writing the Examiner. In 1711 he was made one of the commissioners of the customs; and was sent minister plenipotentiary to France, for the negotiating a peace with that kingdom. Soon after the accession of George I. to the throne in 1714 he presented a memorial to the court of France, requiring the demolition of the canal and new works at Mardyke. In 1715 he was recalled; and upon his arrival being taken up by a warrant from the house of commons, and strictly examined by a committee of the privy council, Robert Walpole, Esq., moved the house of commons for an impeachment against him; and Mr. Prior was ordered into close custody. In 1717 he was excepted out of the act of grace; at the close of that year, however, he was set at liberty. The remainder of his days he spent in tranquillity; and died in 1721. His poems are well known and justly admired.

**PRIOR**, *adj.* } Lat. *prior*. Former; being  
**PRIORITY**, *n. s.* } before something else; anterior; state of being antecedent.

Follow, Cominus, we must follow you,  
Right worthy your *priority*. *Shakspeare:*  
From son to son of the lady, as they should be in  
*priority* of birth. *Hayward.*

Men still affirm that it killeth at a distance, that it poisoneth by the eye, and by *priority* of vision.

*Broune.*

Whenever tempted to do or approve any thing contrary to the duties we are enjoined, let us reflect that we have a *prior* and superior obligation to the commands of Christ.

*Rogers.*

Though he oft renewed the fight,

And almost got *priority* of sight,

He ne'er could overcome her quite. *Swift.*

This observation may assist in determining the dispute concerning the *priority* of Homer and Hesiod.

*Broune.*

**PRIOR**, *n. s.* } Fr. *prieur*. The head of a  
**PRIORESSE**, } convent of monks, inferior in  
**PRIORY**, } dignity to an abbot: prioress, the feminine of this noun: priory is, the convent or establishment over which a prior is placed: prior, says Ayliffe, is such a person, as, in some churches, presides over others in the same churches.

Our abbies and our *priories* shall pay

This expedition's charge.

*Shakspeare. King John.*

When you have vowed, you must not speak with men

But in the presence of the *prioress*. *Shakspeare.*

The reeve, miller, and cook, are distinguished from each other, as much as the mincing lady *prioresse* and the broad speaking wife of Bath. *Dryden.*

Neither she, nor any other, besides the *prior* of the convent, knew any thing of his name.

*Addison's Spectator.*

**PRIORY, ALIEN**. These *priories* were cells of the religious houses in England which belonged to foreign monasteries: for, when manors or tithes were given to foreign convents, the monks, either to increase their own rule, or rather to have faithful stewards of their revenues, built a small convent here for the reception of such a number as they thought proper, and constituted priors over them. Within these cells there was the same distinction as in those *priories* which were cells subordinate to some great abbey; some of these were conventual, and, having priors of their own choosing, thereby became entire societies within themselves, and received the revenues belonging to their several houses for their own use and benefit, paying only the ancient apport, acknowledgment, or obvention, at first the surplussage, to the foreign house; but others depended entirely on the foreign houses, who appointed and removed their priors at pleasure. These transmitted all their revenues to the foreign head houses; for which reason their estates were generally seized to carry on the wars between England and France, and restored to them again on return of peace. These alien *priories* were most of them founded by such as had foreign abbeys, founded by themselves or by some of their family. The whole number is not exactly ascertained; the Monasticon has given a list of 100. Weever says 110. Some of these cells were made indigenous or denizon. The alien *priories* were first seized by Edward I. 1285 on the breaking out of the war between France and England; and it appears from a roll that Edward II. also seized them, though this is not mentioned by our historians: and to these the act of restitution 1 Edw. III. seems to refer. In 1337 Edward III. confiscated their estates and



POUSSIN.



M. PRIOR.



PYTHAGORAS.



PYRREUS II.



PRYNNE.



PTOLEMY LAGUS.



PURCEL.



PUTENDORF.



M. PRIDEAUX.



let out the priories themselves with all their lands and tenements, at his pleasure, for twenty-three years; at the end of which term, peace being concluded between the two nations, he restored their estates in 1361, as appears by his letters patent to that of Montacute, county of Somerset, printed at large in Rymer, vol. vi. p. 311, and translated in Weever's Funeral Monuments, p. 339. At other times he granted their lands, or lay pensions out of them, to divers noblemen. They were also sequestered during Richard II.'s reign, and the head monasteries abroad had the king's licence to sell their lands to other religious houses here, or to any particular persons who wanted to endow others. Henry IV. began his reign with showing some favor to the alien priories, restoring all the conventual ones, only reserving to himself in time of war what they paid in time of peace to the foreign abbeys. They were all dissolved by act 2, Henry V., and all their estates vested in the crown, except some lands granted to the college of Fotheringay. The act of dissolution is not printed in the statute books, but it is to be found entire in Rymer's Fœdera, and in the Parliament Rolls, vol. iv. p. 22. In general, these lands were appropriated to religious uses. Henry VI. endowed his foundations at Eton and Cambridge with the lands of the alien priories. Others were granted in fee to the prelates, nobility, or private persons. Such as remained in the crown were granted by Henry VI., 1440, to archbishop Clicheley, &c., and they became part of his and the royal foundations.

**PRISAGE, n. s.** From prise. See the extract.

*Prisage*, now called butlerage, is a custom whereby the prince challenges out of every bark loaden with wine, two tuns of wine at his price. *Cowell.*

**PRISCIANUS**, an eminent grammarian, born at Cæsarea, who taught at Constantinople with great reputation about the year 525. He composed a work *De Arte Grammatica*, which was first printed by Aldus at Venice in 1476; and another, *De Naturalibus Questionibus*, which he dedicated to Chosroes king of Persia; besides which he translated Dionysius's description of the world into Latin verse.

**PRISM, n. s.** } French *prisme*; Gr. }  
**PRISMATIC, adj.** } *πρισμα*. See Sir I. }  
**PRISMATICALLY, adv.** } Newton's definition }  
 below: the adjective and adverb correspond.

Take notice of the pleasing variety of colours exhibited by the triangular glass, and demand what addition or decrement of either salt, sulphur, or mercury befalls the glass, by being *prismatically* fused; and yet it is known that, without that shape, it would not afford those colours as it does. *Boyle.*

A *prism* of glass is a glass bounded with two equal and parallel triangular ends, and three plain and well polished sides, which meet in three parallel lines, running from the three angles of one end to the three angles of the other end. *Newton.*

If the mass of the earth was cubick, *prismatically*, or any other angular figure, it would follow that one way or part would be drowned, and another be dry. *Derham.*

False eloquence, like the *prismatic* glass,  
 Its gaudy colours spreads on every place;

The face of nature we no more survey,  
 All glares alike, without distinction gay. *Pope.*  
 Here, awful Newton, the dissolving clouds  
 Form, fronting on the sun, thy showery *prism*.  
*Thomson.*

If oyster-shells were thrown into a common fire and calcined for about half an hour, and then brought to a person who had previously been some minutes in a dark room, that many of them would exhibit beautiful irises of *prismatic* colours. *Darwin.*

A **PRISM** is an oblong solid, contained under more than four planes, whose bases are equal, parallel, and alike situated. See **OPTICS**.

**PRISON, n. s. & v. a.** } Fr. *prison*. A strong }  
**PRISONBASE,** } hold in which per- }  
**PRISONER,** } sons are confined; a }  
**PRISONHOUSE,** } gaol: to confine or }  
**PRISONMENT.** } captivate: prison- }  
 house is synonymous with prison: prison-base is a kind of rural play, described in the extract: prisoner, one confined in a prison; a captive: prisonment, confinement; captivity.

The spachies of the court play every Friday at giocho di canni, which is no other than *prisonbase* upon horseback, hitting one another with darts, as the others do with their hands. *Sandys.*

So oft as homeward I from her depart,  
 I go like one that, having lost the field,  
 Is *prisoner* led away with heavy heart.

*Spenser.*

He hath commission  
 To hang Cordelia in the *prison*. *Shakespeare.*

Universal plodding *prisons* up  
 The nimble spirits in the arteries. *Id.*

Cæsar's ill-erected tower,  
 To whose flint bosom my condemned lord  
 Is doomed a *prisoner*. *Id. Richard II.*

I am forbid to tell the secrets of my *prisonhouse*.  
*Shakespeare.*

May be he will not touch young Arthur's life,  
 But hold himself safe in his *prisonment*. *Id.*

There succeeded an absolute victory for the English, the taking of the Spanish general d'Ocampo *prisoner*, with the loss of few of the English.

*Bacon.*

Then did the king enlarge  
 The spleen he *prisoned*. *Chapman's Iliad.*

A *prisoner* is an impatient patient, lingering under the rough hands of a cruel physician; his creditor knows his disease, and hath power to cure him, but takes more pleasure to kill him.

*Essays and Characters, 1638.*

He that is tied with one slender string, such as one resolute struggle would break, he is *prisoner* only at his own sloth, and who will pity his thraldom?

*Decay of Piety.*

For those rebellious here their *prison* ordained.

*Milton.*

Culling their potent herbs and baleful drugs,  
 They, as they sung, would take the *prisoned* soul,  
 And lap it in Elysium. *Id.*

The tyrant Æolus,  
 With power imperial curbs the struggling winds,  
 And sounding tempests in dark *prisons* binds.  
*Dryden.*

He yielded on my word,  
 And, as my *prisoner*, I restore his sword. *Id.*  
 A *prisoner* is troubled, that he cannot go whither he would; and he that is at large is troubled that he does not know whither to go. *L'Estrange.*

He, that has his chains knocked off, and the *prison* doors set open to him, is presently at liberty.  
*Loche.*



At his first coming to his little village, it was as disagreeable to him as a *prison*, and every day seemed too tedious to be endured in so retired a place.

*Law.*

A PRISON, lord Coke observes, is only a place of safe custody, *salva custodia*, not a place of punishment. Any place where a person is confined may be said to be a prison; and, when a process is issued against one, he must, when arrested thereon, either be committed to prison, or be bound in a recognizance with sureties, or else give bail according to the nature of the case, to appear at a certain day in court, there to make answer to what is alleged against him. Where a person is taken and sent to prison in a civil case, he may be released by the plaintiff in the suit; but, if it be for treason or felony, he may not regularly be discharged, until he is indicted of the fact and acquitted. See *LAW*.

PRISON DISCIPLINE. This is a topic upon which every patriotic feeling of the Christian moralist will be exercised; and has been exercised in this country, very salutarily, we may add, for the last ten years. If no second Howard has arisen, investigations into the state of prisons more extensive than his have been successfully carried on in every part of Great Britain during this period, and, in the Society for the Improvement of Prison Discipline, an important centre of communication has been established for the benefit of the civilised world. In the retrospect of their proceedings much that is humiliating to our national pride will appear; but as the exposure of the evils in question has led to a very important diminution of them by legislative enactments, and to the full understanding of the chief causes of the rest, they may be adverted to with considerable satisfaction.

Mr. Buxton's Enquiry whether Crime and Misery are produced or prevented by our present System of Prison Discipline, and his personal exertions in this cause both in and out of parliament, were the first great means of arousing the late attention of the benevolent to the subject. There is a singular honesty in the fabrication of his book; and it is one of those rare cases in which no victory has been gained over the candor and veracity of the writer, by the strong persuasions of a mind under the fullest conviction and most glowing impressions upon the subject of his publication. For the truth of the facts, as they stand in his statements, Mr. Buxton declares himself to require no indulgence. 'Nothing is stated,' says he, '(with the exception of the account of the Philadelphia gaol), which has not come within my own observation, and which has not been confirmed by the concurrent testimony of the gentlemen who have been my companions. The description of the Borough Compter, Tothill Fields, the Penitentiary, the gaols at St. Alban's, at Bury, at Ghent, and at Bristol, have been read to their respective gaolers; and that of Guildford was handed to a magistrate of the county of Surrey, with a request that he would point out any mistakes.' Mr. Buxton adds, 'I have generally mentioned the days on which I visited the gaols, the persons with whom I went, and, where I could do it with propriety, the names of any prisoners whose

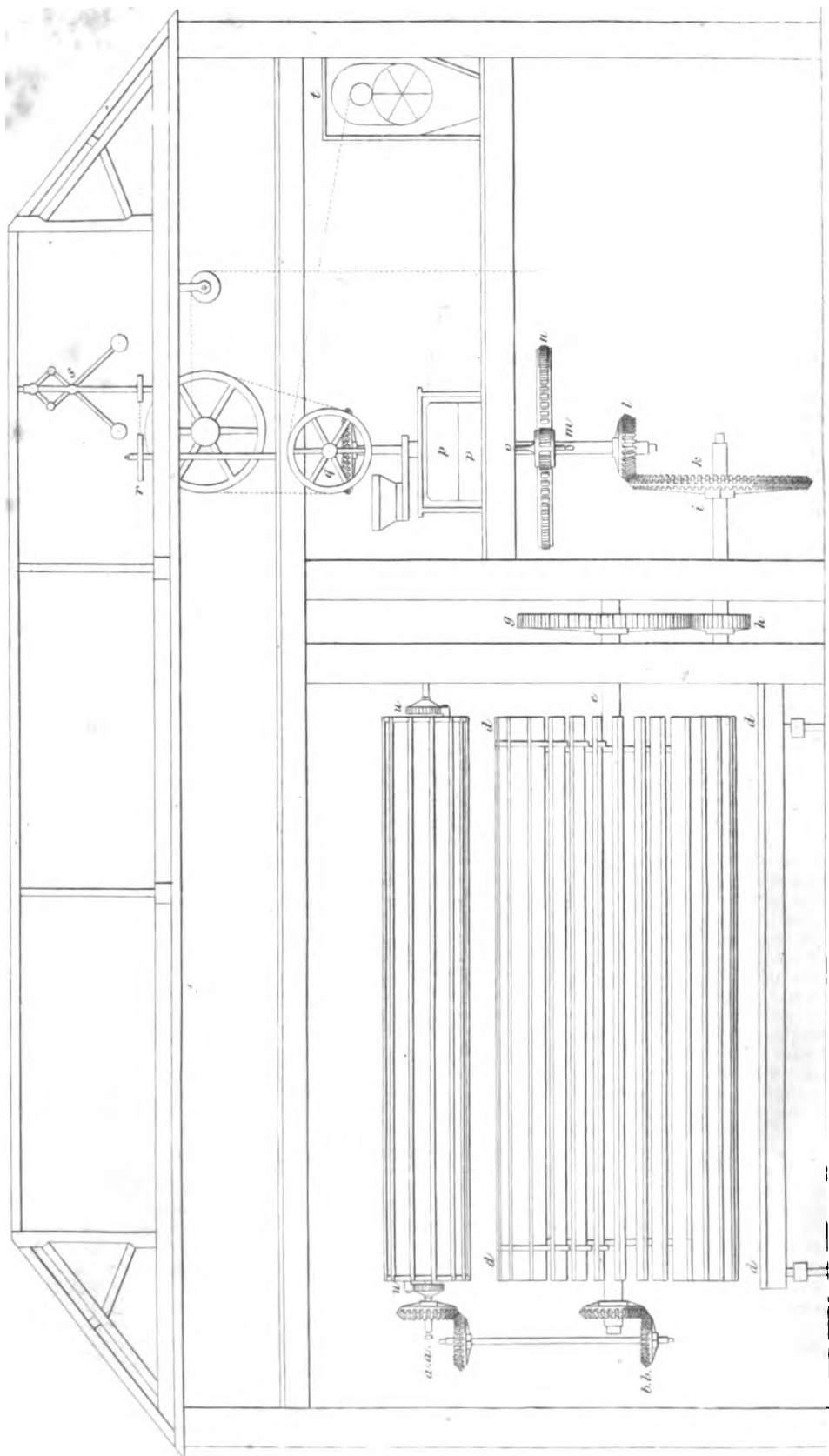
case attracted my particular attention. I have done this as inviting enquiry, as placing my statements in a more tangible shape, and as furnishing a facility for the detection of errors.' For the honor of the writer of the severe censures on our past proceedings which this book contains, such proofs of authenticity speak very forcibly; but, for the honor of the British character, we have only to regret that they carry so high his pretensions to be believed. Of the reasoning in the introductory chapter, we do not hesitate to say that it is in a high degree moral, acute, and manly. We are not of opinion that prisoners should be indulged with Turkey carpets; and we agree in the positions of the committee of aldermen, that debtors should not be placed within the walls of a prison, with greater comparative comforts than the families of the citizens whom they have wronged, or perhaps ruined; neither do we feel any of that contumacious compassion for prisoners because authority and the law have made them such, which, we are persuaded, many do; but we cordially join with Mr. Buxton in opinion, that, where imprisonment is the legal consequence of debt, it should be only imprisonment, without any aggravations, or super-added sufferings; for it is not to be disputed that all beyond mere confinement is beyond the law, which has nowhere authorised any infliction for this cause beyond the evil necessarily implied in the suspension of personal liberty. It is still more plainly evident, that persons under confinement for imputed offences ought not to be subjected to any rigors beyond what may be necessary to secure their detention. Even on convicted delinquents, where safe custody is all that the law has in contemplation, any annexation of unnecessary hardship carries the punishment beyond the law; and, where imprisonment is part or the whole of the punishment, all that is inflicted of suffering or privation, beyond what the sentence has defined, or the common regulations of the prison require, is excess and abuse, so much the more to be dreaded, because it takes place where the eye of the public does not often pierce.

It is quite evident that as little as possible of judicial punishment should be submitted to the discretion or disposition of the gaoler, however necessary it may be to invest him with some degree of coercive authority to preserve the order and peace of the prison. A system of general rules only may and ought to be maintained, in which at least ordinary humanity suffers nothing supplicatory beyond the sentence of the court, in which respect should be had, as far as justice towards all will allow, to the common presumable differences of sentiment arising from previous habits, and in which all mischiefs that may affect the prisoner consequentially and permanently, after the law is satisfied, may, as far as possible, be prevented.

No language can better state the rights of a prisoner accused even of serious crimes than the following:—'You have no right to abridge him of pure air, wholesome and sufficient food, and opportunities of exercise. You have no right to debar him from the craft on which his family depends, if it can be exercised in prison. You



PRISON DISCIPLINE.



London, Published by Thomas Agg, 73, Cheapside

have no right to subject him to suffering from cold, by want of bed-clothing by night, or firing by day; and the reason is plain,—you have taken him from his home, and have deprived him of the means of providing himself with the necessaries or comforts of life, and therefore you are bound to furnish him with moderate indeed, but suitable accommodation.

'You have for the same reason no right to ruin his habits by compelling him to be idle, his morals by compelling him to mix with a promiscuous assemblage of hardened and convicted criminals, or his health by forcing him at night into a damp unventilated cell, with such crowds of companions as very speedily render the air foul and putrid, or make him sleep in close contact with the victims of contagious and loathsome disease, or amidst the noxious effluvia of dirt and corruption. In short, attention to his feelings mental and bodily, a supply of every necessary, abstraction from evil society, the conservation of his health and industrious habits, are the clear, evident, undeniable rights of an unconvicted prisoner. He should be brought to his trial as speedily as possible; for every hour of unnecessary delay, in furnishing him with the opportunity of proving his innocence, is, or at least may be, an hour of unjust imprisonment.

'At his trial, either he is acquitted,—in which case the least you can do is to replace him in the situation you found him, to pay his expenses home, and to furnish him with sufficient to support him till he has had an opportunity of looking out for work: or he is convicted,—and then it is for the law to appoint the punishment which is to follow his offence. That punishment must be inflicted; but you must carefully guard that it be not aggravated, and that circumstances of severity are not found in his treatment which are not found in his sentence. Now no judge ever condemned a man to be half starved with cold by day, or half suffocated with heat by night. Who ever heard of a criminal being sentenced to catch the rheumatism, or the typhus fever? Corruption of morals and contamination of mind, are not the remedies which the law in its wisdom has thought proper to adopt. We should remember, to use the words of a former writer on the subject, 'that disease, cold, famine, nakedness, a contagious and polluted air, are not lawful punishments in the hands of the civil magistrate; nor has he a right to poison or starve his fellow creature, though the greatest of criminals.' The convicted delinquent then has his rights. All measures and practices in prison, which may injure him in any way, are illegal, because they are not specified in his sentence:—he is therefore entitled to a wholesome atmosphere, decent clothing and bedding, and a diet sufficient to support him.

'But besides the rights of the individual, there are duties to the community:—*Parum est improbos coercere pœnâ, nisi probos efficias disciplinâ.* One of the most important of these duties is, that you should not send forth the man committed to your tuition in any respect a worse man, a less industrious, a less sober, or a less competent man, than when he entered your

VOL. XVIII.

walls. Good policy requires that, if possible, you dismiss him improved.

'For the improvement of the unconvicted prisoner you should labor, as a recompense for his confinement before trial—that thus you may convert the suspicion of crime into its prevention in future—that thus you may addict him to such habits, and instil such principles, and impart such instruction, as may repair the damage you have done him; and that he, being amerced of one period of his life, may be enabled to spend the remainder more respectably.

'For the improvement of the debtor you should labor, because the grand causes of debt are sickness, idleness, or intemperance:—you must, therefore, provide against its recurrence by those measures which may secure the health, the industry, and the sobriety of your prisoners. The convicted criminal is also entitled to your care. Our law is not, in its true spirit, whatever it may be in its modern enactments, a system of bloody vengeance; it does not say, so much evil is repaired by so much misery inflicted. A merciful and enlightened jurisprudence, like the Author of all that is merciful and wise, does not rejoice in the death of a sinner; but rather that he should turn from his wickedness, and live. Punishments are inflicted that crime may be prevented, and crime is prevented by the reformation of the criminal. This may be accomplished. The prisoner, being separated from his former associates, ceases to think as they think; he has time for recollection and repentance; and seclusion will humble the most haughty, and often reform the most abandoned.

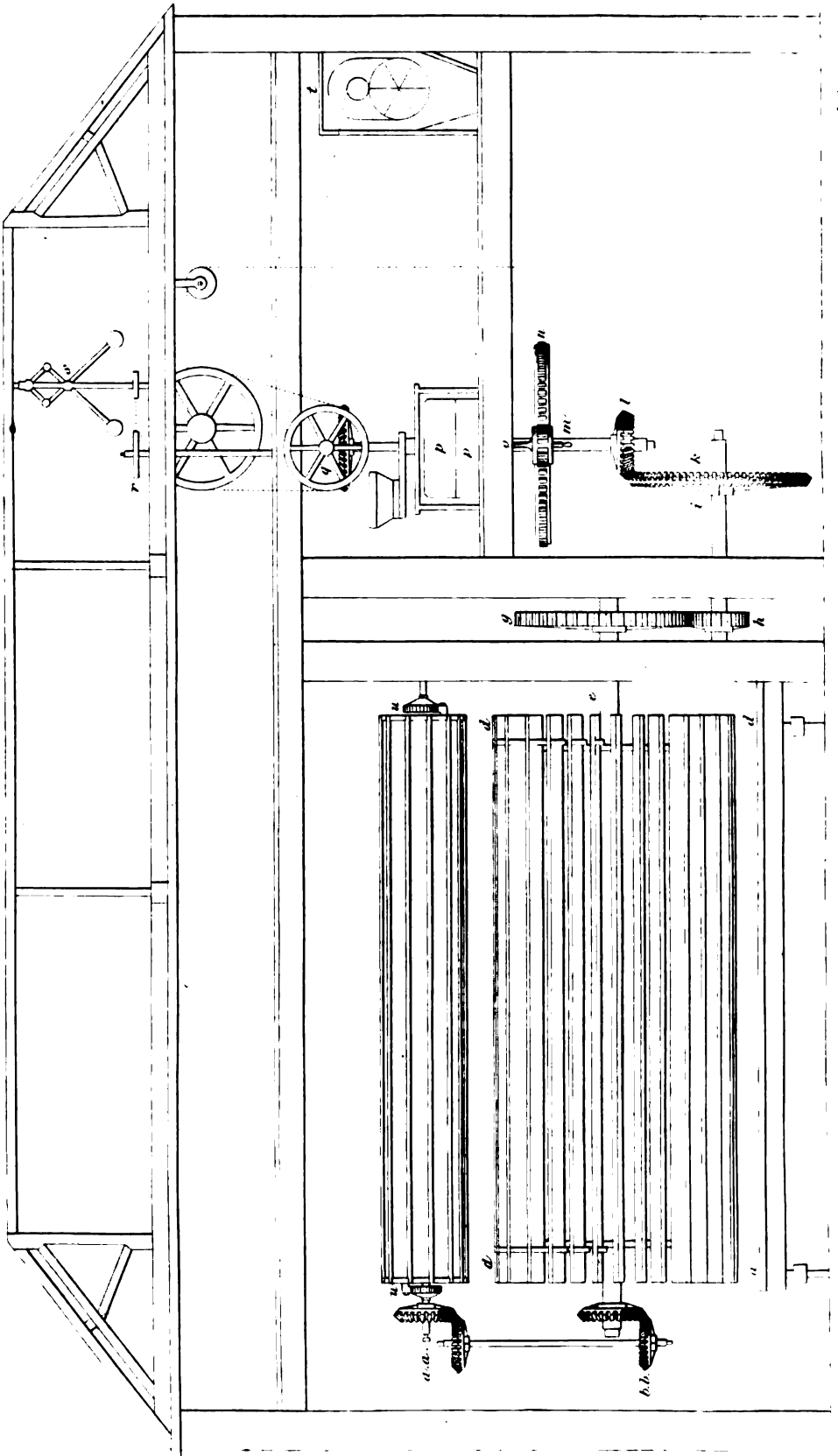
'It is then necessary that he sleep alone, and that he be alone during a great portion of the day.

'But, as idleness is one great cause of sin, industry is one great means of reformation. Measures must therefore be taken for his constant employment, and for making that employment agreeable, by allowing him to share largely in its profits.

'The use of stimulating liquors is often the cause, and always the concomitant of crime. These, therefore, must be forbidden. The want of education is found to be a great source of crime; for this, therefore, a provision must be made. The neglect of religious duties is the grand cause of crime. Ministers of religion must, therefore, be induced to give their active and zealous labors to the prisoners daily, reading prayers in public, and giving private instruction. The assiduous services of such men will not be fruitless. Mr. Robinson of Leicester declared that no part of his ministry had been so signally successful as that in the gaols; and the Ladies' Committee of Newgate have many proofs that reformation may be accomplished, even amongst the most dissolute and abandoned.'—Buxton, p. 11—15.

Mr. Buxton maintains, that, as our prison discipline stood in 1815, the prisoner, immediately on his commitment, was made to experience the violation of all these rights. In language still but too applicable in various parts of the country, 'You give him,' says he ' (the pri-

PRISON DISCIPLINE.



London. Published by Thomas Agnew & Sons, 15, Abchurch-lane.

25, Mark Lane.

have no right to subject him to suffering from cold, by want of bed-clothing by night, or firing by day; and the reason is plain,—you have taken him from his home, and have deprived him of the means of providing himself with the necessaries or comforts of life, and therefore you are bound to furnish him with moderate indeed, but suitable accommodation.

‘You have for the same reason no right to ruin his habits by compelling him to be idle, his morals by compelling him to mix with a promiscuous assemblage of hardened and convicted criminals, or his health by forcing him at night into a damp unventilated cell, with such crowds of companions as very speedily render the air foul and putrid, or make him sleep in close contact with the victims of contagious and loathsome disease, or amidst the noxious effluvia of dirt and corruption. In short, attention to his feelings mental and bodily, a supply of every necessary, abstraction from evil society, the conservation of his health and industrious habits, are the clear, evident, undeniable rights of an unconvicted prisoner. He should be brought to his trial as speedily as possible; for every hour of unnecessary delay, in furnishing him with the opportunity of proving his innocence, is, or at least may be, an hour of unjust imprisonment.

‘At his trial, either he is acquitted,—in which case the least you can do is to replace him in the situation you found him, to pay his expenses home, and to furnish him with sufficient to support him till he has had an opportunity of looking out for work: or he is convicted,—and then it is for the law to appoint the punishment which is to follow his offence. That punishment must be inflicted; but you must carefully guard that it be not aggravated, and that circumstances of severity are not found in his treatment which are not found in his sentence. Now no judge ever condemned a man to be half starved with cold by day, or half suffocated with heat by night. Who ever heard of a criminal being sentenced to catch the rheumatism, or the typhus fever? Corruption of morals and contamination of mind, are not the remedies which the law in its wisdom has thought proper to adopt. We should remember, to use the words of a former writer on the subject, ‘that disease, cold, famine, nakedness, a contagious and polluted air, are not lawful punishments in the hands of the civil magistrate; nor has he a right to poison or starve his fellow creature, though the greatest of criminals.’ The convicted delinquent then has his rights. All measures and practices in prison, which may injure him in any way, are illegal, because they are not specified in his sentence:—he is therefore entitled to a wholesome atmosphere, decent clothing and bedding, and a diet sufficient to support him.

‘But besides the rights of the individual, there are duties to the community:—*Parum est improbos coercere panâ, nisi probos efficias disciplinâ.* One of the most important of these duties is, that you should not send forth the man committed to your tuition in any respect a worse man, a less industrious, a less sober, or a less intelligent man, than when he entered your

walls. Good policy requires that, if possible, you dismiss him improved.

‘For the improvement of the unconvicted prisoner you should labor, as a recompense for his confinement before trial—that thus you may convert the suspicion of crime into its prevention in future—that thus you may addict him to such habits, and instil such principles, and impart such instruction, as may repair the damage you have done him; and that he, being amerced of one period of his life, may be enabled to spend the remainder more respectably.

‘For the improvement of the debtor you should labor, because the grand causes of debt are sickness, idleness, or intemperance:—you must, therefore, provide against its recurrence by those measures which may secure the health, the industry, and the sobriety of your prisoners. The convicted criminal is also entitled to your care. Our law is not, in its true spirit, whatever it may be in its modern enactments, a system of bloody vengeance; it does not say, so much evil is repaired by so much misery inflicted. A merciful and enlightened jurisprudence, like the Author of all that is merciful and wise, does not rejoice in the death of a sinner; but rather that he should turn from his wickedness, and live. Punishments are inflicted that crime may be prevented, and crime is prevented by the reformation of the criminal. This may be accomplished. The prisoner, being separated from his former associates, ceases to think as they think; he has time for recollection and repentance; and seclusion will humble the most haughty, and often reform the most abandoned.

‘It is then necessary that he sleep alone, and that he be alone during a great portion of the day.

‘But, as idleness is one great cause of sin, industry is one great means of reformation. Measures must therefore be taken for his constant employment, and for making that employment agreeable, by allowing him to share largely in its profits.

‘The use of stimulating liquors is often the cause, and always the concomitant of crime. These, therefore, must be forbidden. The want of education is found to be a great source of crime; for this, therefore, a provision must be made. The neglect of religious duties is the grand cause of crime. Ministers of religion must, therefore, be induced to give their active and zealous labors to the prisoners daily, reading prayers in public, and giving private instruction. The assiduous services of such men will not be fruitless. Mr. Robinson of Leicester declared that no part of his ministry had been so signally successful as that in the gaols; and the Ladies’ Committee of Newgate have many proofs that reformation may be accomplished, even amongst the most dissolute and abandoned.’—Buxton, p. 11—15.

Mr. Buxton maintains, that, as our prison discipline stood in 1815, the prisoner, immediately on his commitment, was made to experience the violation of all these rights. In language still but too applicable in various parts of the country, ‘You give him,’ says he ‘(the pri-

soner) leisure, and for the employment of that leisure you give him tutors in every branch of iniquity. You have taken no pious pains to turn him from the error of his ways, and to save his soul alive. You have not cherished the latent seeds of virtue; you have not profited by the opportunity of awakening remorse for his past misconduct. His Saviour's awful name becomes, indeed, familiar to his lips, because he learns to use it to give zest to his conversation, and vigor to his execrations; but all that Saviour's office, his tenderness, and compassion, and mercy to the returning sinner, are topics of which he learns no more than the beasts that perish.'

That the reader may have before him a sort of specimen of some modern British prisons, we will exhibit a few particulars of the former condition of the Borough Compter. Of thirteen persons confined on criminal charges, there were five cases of fever. In a room, seven feet by nine, three persons had slept the night before his first visit, one of whom was ill with fever, with which the other two were infected, and so found on his second visit. Till lately no surgeon or apothecary; no infirmary; no separation of a sick criminal, however infectious his disorder. The apartments of the male debtors on the same floor with the female prisoners, and separated only by doors seven feet asunder, which are always open in the day time, and in hot weather at night. One yard only for male and female debtors; no cooking utensils—no soap—no work or employment provided—no school. We are not to wonder at the gaoler's declaration that, in an experience of nine years, he had never known an instance of reformation. In Guildford gaol at this period, there was no infirmary—no chapel—no work—no classification.

So far back as 1815 we find from Mr. Buxton that a committee of aldermen of London was appointed to visit several gaols in England, and directed to compare the allowances, and the rules and orders, then existing in the prisons of the metropolis, with those of Gloucester, and elsewhere, and to draw out such new system of allowances, and such new code of laws, as should appear to them to be salutary, and adapted to the prisons in question. That such of our readers as have not yet acquired any knowledge of this subject may have their attention drawn towards it, we offer to their notice the following improvements which their reports suggested,

' 1. That the gaol should be divided into day-rooms, and distinct yards, having arcades in each.

' 2. That warm and cold baths should be provided, as also ovens, for fumigating clothes.

' 3. Circular apertures of open iron work, for the purpose of a thorough ventilation, should be made.

' 4. Such shutters and windows shall be constructed as shall exclude the possibility of the prisoners' looking into any other apartment or yard.

' 5. That day cells for labor should be distinct from the sleeping cells, as also exclusive cells for refractory prisoners.

' 6. King's evidence should be precluded from a possibility of communication with the other prisoners.

' 7. That gratings should be fitted up in the apartments where the visitors of felons are admitted; and so constructed as not to admit of any dangerous instrument being passed through.

' 8. Apartments for the reception of friends of the debtors should be constructed.

' 9. The chapel should be so constructed that one class of prisoners should not be seen by another class.

' With respect to the classification of prisoners, according to their several degrees of offence:—

' 10. That those before trial should never be mixed with those convicted; and that the respective classes should be arranged as nearly as possible in the following order:—

1. Capital felons.

2. Simple felony, and first offence.

3. Criminals under sentence of death.

4. Misdemeanors and persons wanting sureties.

5. Misdemeanors of the grossest kind.

6. Children.

' With respect to the internal regulations of the prison:—

' 11. That all prisoners on coming in should be examined by the surgeon, and should be immediately washed, and their clothes purified; and proper apparel should be provided for their use in the mean time.

' 12. That the prisoners should be required to wash themselves, at least once every day, at places appropriated for that purpose; and that clean towels of open network be supplied for their use, twice a week.

' 13. That no beer should be admitted; nor wine, nor other strong liquors, except to the infirmaries, by direction of the surgeon, or to the debtors. No debtor to be allowed to have to himself more than one pint of wine, or one quart of strong beer per day.

' 14. The friends of criminals to be admitted between the hours of nine in the morning, and two in the afternoon; and not to be allowed to converse with the prisoners, but in the presence of the keeper or turnkey, except solicitors for the purpose of preparing defences.

' 15. The visitors of debtors to be admitted only at stated hours, into the rooms allotted for their reception, and not into the interior of the gaol, unless by order of a magistrate.

' 16. Not any description of prisoners should be permitted to enter into the sleeping-rooms during the day.

' 17. The transports, and those sentenced to hard labor or solitary confinement, to be kept in constant work suitable to their ability and strength; such prisoners not be excused from work, unless on account of total inability, ill health, or other sufficient cause certified by the surgeon.

' 18. Prisoners to be discharged in the morning, and, if they have acquired any trade in the prison, proper tools to be given to them.

' 19. That gaming of every kind should be strictly prohibited.

' With respect to the allowances of food:—

' 20. That one pound and a half of bread, at least one day old, should be allowed to each pri-

sooner daily, and one pint of good gruel for breakfast,—and upon good behaviour half a pound of meat on a Sunday.

'21. That proper scales, weights, and measures should be provided in the gaol.

'22. A messenger to be appointed for the accommodation of the debtors.

'23. A laundry, and a matron under whose directions the female prisoners should do all the washing.

'24. A bell to be fixed for sounding alarms in cases of escape.

'25. The chaplain to keep a diary of observations, subject to the inspection of the visiting magistrates. He should read prayers, and preach a sermon every Sunday morning, and read prayers in the evening, and also read prayers every Wednesday and Friday. He should visit the sick, instruct prisoners in their moral duties, give spiritual advice, and religious consolation to such as may desire it. He should distribute amongst them religious books, and form a sort of school for the instruction of the children.'—Buxton, p. 61—64.

Among the creditable exceptions to the neglected state of our prisons at this period stood the gaol of Bury; where the benefits of a simple mechanical, as well as moral arrangement, have been practically and decisively displayed for many years; and, connected with which, the name of Mr. Orridge, the governor, will long be mentioned with honor. The facts, as Mr. Buxton observes, will speak for themselves:—and the writer of this paper has verified them. No prisoner, at the time of Mr. B's visit, was ill; in eighteen years but one prisoner had escaped; in every 100 of the prisoners not five were found who had been there before; never any riots, or quarrelling, or swearing. Yet, for twenty years, Mr. Orridge informed us he had never used irons in this prison.

The researches of the modern advocates of prison reform have not, as we have intimated, been confined to their own country.—At the Maison de Force, at Ghent, the same practical testimony is borne to the good effects of a sound system of gaol discipline. Here was observed by Mr. Buxton an entire separation of men from women, the sickly from the healthy, the untried from the convicted, and the misdemeanants from the felons. 'The building, being yet unfinished, does not admit of more subdivisious of classes, which certainly might be carried farther, and probably will when the capacity of the structure will admit of it.' A very important feature of the system of classification is that of children from men and women; and in general it may be observed that the division into classes should have reference to moral as well as technical distinctions. The utmost order and regularity were found to prevail in this prison. While at work, no prisoner was allowed to speak; and so strictly was the rule observed that the questions put to them by Mr. Buxton were not answered. No noise but the noise of the shuttle. Corporal punishment, formerly allowed, was then dispensed with, because, as the governor stated, it was found to be unnecessary. The penalty was privation of work. The behaviour of the prisoners was

subdued, civil, submissive, and decent throughout—their persons cleanly, and their looks cheerful—all the rooms clean and sweet. 'By this excellent system,' says Mr. Buxton, 'the prisoner gains habits of order, self-restraint, and subjection of mind.—The most boisterous tempest is not more distinct from the serenity of a summer's evening; the wildest beast of prey is not more different from our domesticated animals, than are the noise, contention, licentiousness, and tumult of Newgate, from the quietness, industry, and regularity of the Maison de Force.

In the prison of Philadelphia, where the great features of discipline are distribution, employment, and religious instruction, the effects are still more impressive. Mr. Turnbull, speaking of the various trades carried on in the prison, of blacksmith, carpenter, turner, shoemaker, tailor, weavers of cloth, linen, and carpeting, grinding of corn, sawing and polishing marble, cutting stone, and rasping logwood, observes, 'that there was such a spirit of industry on every side, and such contentment pervaded the countenances of all, that it was with difficulty he divested himself of the idea that these men surely were not convicts, but accustomed to labor from their infancy.' 'An account is opened with every prisoner; he is debited with the amount of the sum stolen, or embezzled, with the expenses of his prosecution, with the fine imposed by the court, with the cost of his board and clothes; and he is credited with the produce of his labor.' All the dress, every mattress, sheet, rug, and coverlid, is woven by the male, and made up by the female prisoners. All laughing, singing, and conversation, during the hours of work, are prohibited; and the silence which is observed is the first and most striking circumstance which arrests the attention of a stranger. Great attention is paid to the promotion of moral and religious improvement by a supply of useful books, and by the regular performance of divine service. No keeper is permitted to carry a stick, or any offensive weapon. No fetters or irons are seen in the prison, the punishment is solitude, and no instance has occurred of its being necessary to inflict it upon the same person twice. In the four years preceding the commencement of the new system 104 prisoners escaped: in the four succeeding (except on the day of its establishment) not one escaped.

Under the old system the number of the most heinous crimes committed in the city and county from January, 1787, to June, 1791, was 129. Under the new system in the whole state, during the same period, twenty-four. 'At the time of the yellow fever, in 1793, great difficulty was found in obtaining nurses and attendants for the sick at Bush-hill hospital. Recourse was had to the prison. The request was made, and the apparent danger stated to the convicts. As many offered as were wanted. They continued faithful till the dreadful scene was closed—none of them making a demand for their services till all were discharged.

'One man committed for a burglary, who had seven years to serve, observed, when the request was made to him, that having offended society



soner) leisure, and for the employment of that leisure you give him tutors in every branch of iniquity. You have taken no pious pains to turn him from the error of his ways, and to save his soul alive. You have not cherished the latent seeds of virtue; you have not profited by the opportunity of awakening remorse for his past misconduct. His Saviour's awful name becomes, indeed, familiar to his lips, because he learns to use it to give zest to his conversation, and vigor to his execrations; but all that Saviour's office, his tenderness, and compassion, and mercy to the returning sinner, are topics of which he learns no more than the beasts that perish.'

That the reader may have before him a sort of specimen of some modern British prisons, we will exhibit a few particulars of the former condition of the Borough Compter. Of thirteen persons confined on criminal charges, there were five cases of fever. In a room, seven feet by nine, three persons had slept the night before his first visit, one of whom was ill with fever, with which the other two were infected, and so found on his second visit. Till lately no surgeon or apothecary; no infirmary; no separation of a sick criminal, however infectious his disorder. The apartments of the male debtors on the same floor with the female prisoners, and separated only by doors seven feet asunder, which are always open in the day time, and in hot weather at night. One yard only for male and female debtors; no cooking utensils—no soap—no work or employment provided—no school. We are not to wonder at the gaoler's declaration that, in an experience of nine years, he had never known an instance of reformation. In Guildford gaol at this period, there was no infirmary—no chapel—no work—no classification.

So far back as 1815 we find from Mr. Buxton that a committee of aldermen of London was appointed to visit several gaols in England, and directed to compare the allowances, and the rules and orders, then existing in the prisons of the metropolis, with those of Gloucester, and elsewhere, and to draw out such new system of allowances, and such new code of laws, as should appear to them to be salutary, and adapted to the prisons in question. That such of our readers as have not yet acquired any knowledge of this subject may have their attention drawn towards it, we offer to their notice the following improvements which their reports suggested,

'1. That the gaol should be divided into day-rooms, and distinct yards, having arcades in each.

'2. That warm and cold baths should be provided, as also ovens, for fumigating clothes.

'3. Circular apertures of open iron work, for the purpose of a thorough ventilation, should be made.

'4. Such shutters and windows shall be constructed as shall exclude the possibility of the prisoners' looking into any other apartment or yard.

'5. That day cells for labor should be distinct from the sleeping cells, as also exclusive cells for refractory prisoners.

'6. King's evidence should be precluded from a possibility of communication with the other prisoners.

'7. That gratings should be fitted up in the apartments where the visitors of felons are admitted; and so constructed as not to admit of any dangerous instrument being passed through.

'8. Apartments for the reception of friends of the debtors should be constructed.

'9. The chapel should be so constructed that one class of prisoners should not be seen by another class.

'With respect to the classification of prisoners, according to their several degrees of offence:—

'10. That those before trial should never be mixed with those convicted; and that the respective classes should be arranged as nearly as possible in the following order:—

1. Capital felons.

2. Simple felony, and first offence.

3. Criminals under sentence of death.

4. Misdemeanors and persons wanting sureties.

5. Misdemeanors of the grossest kind.

6. Children.

'With respect to the internal regulations of the prison:—

'11. That all prisoners on coming in should be examined by the surgeon, and should be immediately washed, and their clothes purified; and proper apparel should be provided for their use in the mean time.

'12. That the prisoners should be required to wash themselves, at least once every day, at places appropriated for that purpose; and that clean towels of open network be supplied for their use, twice a week.

'13. That no beer should be admitted; nor wine, nor other strong liquors, except to the infirmaries, by direction of the surgeon, or to the debtors. No debtor to be allowed to have to himself more than one pint of wine, or one quart of strong beer per day.

'14. The friends of criminals to be admitted between the hours of nine in the morning, and two in the afternoon; and not to be allowed to converse with the prisoners, but in the presence of the keeper or turnkey, except solicitors for the purpose of preparing defences.

'15. The visitors of debtors to be admitted only at stated hours, into the rooms allotted for their reception, and not into the interior of the gaol, unless by order of a magistrate.

'16. Not any description of prisoners should be permitted to enter into the sleeping-rooms during the day.

'17. The transports, and those sentenced to hard labor or solitary confinement, to be kept in constant work suitable to their ability and strength; such prisoners not to be excused from work, unless on account of total inability, ill health, or other sufficient cause certified by the surgeon.

'18. Prisoners to be discharged in the morning, and, if they have acquired any trade in the prison, proper tools to be given to them.

'19. That gaming of every kind should be strictly prohibited.

'With respect to the allowances of food:—

'20. That one pound and a half of bread, at least one day old, should be allowed to each pri-

soner daily, and one pint of good gruel for breakfast,—and upon good behaviour half a pound of meat on a Sunday.

'21. That proper scales, weights, and measures should be provided in the gaol.

'22. A messenger to be appointed for the accommodation of the debtors.

'23. A laundry, and a matron under whose directions the female prisoners should do all the washing.

'24. A bell to be fixed for sounding alarms in cases of escape.

'25. The chaplain to keep a diary of observations, subject to the inspection of the visiting magistrates. He should read prayers, and preach a sermon every Sunday morning, and read prayers in the evening, and also read prayers every Wednesday and Friday. He should visit the sick, instruct prisoners in their moral duties, give spiritual advice, and religious consolation to such as may desire it. He should distribute amongst them religious books, and form a sort of school for the instruction of the children.'—Buxton, p. 61—64.

Among the creditable exceptions to the neglected state of our prisons at this period stood the gaol of Bury; where the benefits of a simple mechanical, as well as moral arrangement, have been practically and decisively displayed for many years; and, connected with which, the name of Mr. Orridge, the governor, will long be mentioned with honor. The facts, as Mr. Buxton observes, will speak for themselves:—and the writer of this paper has verified them. No prisoner, at the time of Mr. B's visit, was ill; in eighteen years but one prisoner had escaped; in every 100 of the prisoners not five were found who had been there before; never any riots, or quarrelling, or swearing. Yet, for twenty years, Mr. Orridge informed us he had never used irons in this prison.

The researches of the modern advocates of prison reform have not, as we have intimated, been confined to their own country.—At the *Maison de Force*, at Ghent, the same practical testimony is borne to the good effects of a sound system of gaol discipline. Here was observed by Mr. Buxton an entire separation of men from women, the sickly from the healthy, the untried from the convicted, and the misdemeanants from the felons. 'The building, being yet unfinished, does not admit of more subdivisions of classes, which certainly might be carried farther, and probably will when the capacity of the structure will admit of it.' A very important feature of the system of classification is that of children from men and women; and in general it may be observed that the division into classes should have reference to moral as well as technical distinctions. The utmost order and regularity were found to prevail in this prison. While at work, no prisoner was allowed to speak; and so strictly was the rule observed that the questions put to them by Mr. Buxton were not answered. No noise but the noise of the shuttle. Corporal punishment, formerly allowed, was then dispensed with, because, as the governor stated, it was found to be unnecessary. The penalty was privation of work. The behaviour of the prisoners was

subdued, civil, submissive, and decent throughout—their persons cleanly, and their looks cheerful—all the rooms clean and sweet. 'By this excellent system,' says Mr. Buxton, 'the prisoner gains habits of order, self-restraint, and subjection of mind.—The most boisterous temper is not more distinct from the serenity of a summer's evening; the wildest beast of prey is not more different from our domesticated animals, than are the noise, contention, licentiousness, and tumult of Newgate, from the quietness, industry, and regularity of the *Maison de Force*.'

In the prison of Philadelphia, where the great features of discipline are distribution, employment, and religious instruction, the effects are still more impressive. Mr. Turnbull, speaking of the various trades carried on in the prison, of blacksmith, carpenter, turner, shoemaker, tailor, weavers of cloth, linen, and carpeting, grinding of corn, sawing and polishing marble, cutting stone, and rasping logwood, observes, 'that there was such a spirit of industry on every side, and such contentment pervaded the countenances of all, that it was with difficulty he divested himself of the idea that these men surely were not convicts, but accustomed to labor from their infancy.' 'An account is opened with every prisoner; he is debited with the amount of the sum stolen, or embezzled, with the expenses of his prosecution, with the fine imposed by the court, with the cost of his board and clothes; and he is credited with the produce of his labor.' All the dress, every mattress, sheet, rug, and coverlid, is woven by the male, and made up by the female prisoners. All laughing, singing, and conversation, during the hours of work, are prohibited; and the silence which is observed is the first and most striking circumstance which arrests the attention of a stranger. Great attention is paid to the promotion of moral and religious improvement by a supply of useful books, and by the regular performance of divine service. No keeper is permitted to carry a stick, or any offensive weapon. No fetters or irons are seen in the prison, the punishment is solitude, and no instance has occurred of its being necessary to inflict it upon the same person twice. In the four years preceding the commencement of the new system 104 prisoners escaped: in the four succeeding (except on the day of its establishment) not one escaped.

Under the old system the number of the most heinous crimes committed in the city and county from January, 1787, to June, 1791, was 129. Under the new system in the whole state, during the same period, twenty-four. 'At the time of the yellow fever, in 1793, great difficulty was found in obtaining nurses and attendants for the sick at Bush-hill hospital. Recourse was had to the prison. The request was made, and the apparent danger stated to the convicts. As many offered as were wanted. They continued faithful till the dreadful scene was closed—none of them making a demand for their services till all were discharged.

'One man committed for a burglary, who had seven years to serve, observed, when the request was made to him, that having offended society

he should be happy to render it some services for the injury; and, if they could only place a confidence in him, he would go with cheerfulness. He went—he never left it but once, and then by permission to obtain some articles in the city. His conduct was so remarkable as to engage the attention of the managers, who made him a deputy-steward; gave him the charge of the doors, to prevent improper persons from going into the hospital, to preserve order in and about the house, and to see that nothing came to or went from it improperly. He was paid, and after receiving an extra compensation, at his discharge married one of the nurses. Another man, convicted of a robbery, was taken out for the purpose of attending a horse and cart, to bring such provisions from the vicinity of the city as were there deposited for the use of the poor, by those who were afraid to come in. He had the sole charge of the cart and conveying the articles for the whole period. He had many years to serve, and might at any time have departed with the horse, cart, and provisions. He despised, however, such a breach of trust, and returned to the prison. He was soon after pardoned, with the thanks of the inspectors. Another instance of the good conduct of the prisoners during the sickness happened among the women. When request was made to them to give up their bedsteads, for the use of the sick at the hospital, they cheerfully offered even their bedding, &c. When a similar request was made to the debtors, they all refused. A criminal, one of the desperate gangs that had so long infested the vicinity of Philadelphia, for several years before the alteration of the system, on being discharged, called upon one of the inspectors, and addressed him in the following manner:—‘ Mr. ———, I have called to return you my thanks for your kindness to me while under sentence, and to perform a duty which I think I owe to society, it being all in my power at this time to afford. You know my conduct and my character have been once bad and lost, and therefore whatever I might say would have but little weight were I not now at liberty. Pursue your present plan and you will have neither burglaries nor robberies in this place.’

Of the very deplorable state of the females in Newgate before Mrs. Fry's well-known visits no one can be ignorant; of the change produced by the Bible, a school, and constant employment, among these desolate and vicious beings in a short compass of time, it is difficult to form an adequate conception. At the first visit, says a young lady who accompanied Mrs. Fry, and who related the circumstances to Mr. Buxton, ‘ the railing was crowded with half-naked women, struggling together for the front situations with the most boisterous violence, and begging with the utmost vociferation. She felt as if she was going into a den of wild beasts, and she well recollects quite shuddering when the door closed upon her, and she was locked in, with such a herd of novel and desperate companions. This day, however, the school surpassed their utmost expectations; their only pain arose from the numerous and pressing applications made by young women, who longed to be taught and em-

ployed. The narrowness of the room rendered it impossible to yield to these requests, whilst a denial seemed a sentence of destruction, excluding every hope, and almost every possibility of reformation.’—p. 122.

The visits of these ladies were incessant. They often spent the whole day in the conduct of this extraordinary school, joining in the employment, sharing the meals, and engaged in the inspection of their pupils. The first experiment was upon the untried part of the prisoners, and the success with which it was attended encouraged an extension of the scheme to those who had undergone their trials, and the inauguration of this great undertaking is thus set forth by Mr. Buxton:—‘ Nothing now remained but to prepare the room; and this difficulty was obviated by the sheriffs sending their carpenters. The former laundry speedily underwent the necessary alterations—was cleaned and white-washed—and in a very few days the Ladies' Committee assembled in it all the tried female prisoners. One of the ladies began by telling them the comforts derived from industry and sobriety, the pleasure and the profit of doing right, and contrasted the happiness and the peace of those who are dedicated to a course of virtue and religion, with that experienced in their former life, and its present consequences; and, describing their awful guilt in the sight of God, appealed to themselves, whether its wages, even here, were not utter misery and ruin. She then dwelt upon the motives which had brought the ladies into Newgate; they had left their homes and their families, to mingle amongst those from whom all others fled; animated by an ardent and affectionate desire to rescue their fellow-creatures from evil, and to impart to them that knowledge which they, from their education and circumstances, had been so happy as to receive. She then told them that the ladies did not come with any absolute and authoritative pretensions; that it was not intended they should command, and the prisoners obey; but that it was to be understood, all were to act in concert; that not a rule should be made, or a monitor appointed, without their full and unanimous concurrence; that for this purpose each of the rules should be read, and put to the vote; and she invited those who might feel any disinclination to any particular freely to state their opinion’—Buxton, p. 127, 128. The rules were then read, and every hand was held up in testimony of approbation.

At the date of Mr. Buxton's book a year had elapsed since this labor of love had been in operation, and it is surely enough to state that ‘ only one lady had in all that time heard an oath; that though card-playing had in some instances been resumed, and about half a dozen instances of intoxication had occurred, the rules had been generally observed; that the ladies had been treated with uniform respect and gratitude; that they had reason to rejoice in the improved conduct, and, as they trust, in the confirmed moral habits of the prisoners; several had received the rudiments of education, and had learned for the first time the truth of the Christian religion; many had left the prison: who were them filling their stations in life uprightly and respectably. Only

one discharged from the prison had been again committed for a transgression of the law.'

The five golden rules of which the plan of this proceeding was composed were:—

'1st. 'Religious instruction,'—perusal of the Scriptures morning and evening. They have found the prisoners remarkably ignorant of the first principles of Christianity, and they have reason to think that a prison, in excluding many objects of worldly interest, occupation, and pleasure, and in the pause which it produces in the career of life, and in the apprehensions it sometimes excites, is well calculated for the inculcation of religious impressions.

2dly, Constant employment is a grand and an indispensable requisite in the reformation of a prison. They would feel themselves totally incompetent to restrain the passions of this unruly race, if their minds were not engaged in useful and active objects.

3dly, Rules simple and lenient, but rigidly enforced, and, if possible, the concurrence of the prisoners in their formation.

4thly, Classification and separation to the greatest possible extent.

5thly, They recommend that prisoners should be treated as human beings, with human feelings; with that disinterested kindness which will engage their affections; yet as human beings degraded by crime—with that degree of restraint, and with those symbols of degradation, which may recal a sense of their guilt, and humble their pride.'—Buxton, p. 139.

Of the success of Mrs. Fry and her associates it was well said at the time: 'Let us hear no more of the difficulty of regulating provincial prisons, when the prostitute felons of London have been thus easily reformed and converted. Let us never again be told of the impossibility of repressing drunkenness and profligacy, or introducing habits of industry in small establishments, when this great crater of vice and corruption has been thus stilled and purified. And above all let there be an end of the pitiful apology of the want of funds, or means, or agents, to effect those easier improvements, when women from the middle ranks of life—when quiet unassuming matrons, unaccustomed to business, or to any but domestic exertion, have, without funds, without agents, without aid or encouragement of any description, trusted themselves within the very centre of infection and despair, and, by opening their hearts only, and not their purses, have effected, by the mere force of kindness, gentleness, and compassion, a labor, the like to which does not remain to be performed, and which has smoothed the way, and ensured success, to all similar labors. We cannot envy the happiness which Mrs. Fry must enjoy from the consciousness of her own great achievements;—but there is no happiness or honor of which we should be so proud to be partakers: And we seem to relieve our own hearts of their share of national gratitude in thus placing on her simple and modest brow that truly civic crown, which far outshines the laurels of conquest, or the coronals of power—and can only be outshone itself by those wreaths of imperishable glory which await the champions of faith and charity in a

higher state of existence.'—Edinburgh Review, September, 1818.

We have been detained longer than we anticipated by the topics of Mr. Buxton's admirable volume; but they have enabled us to bring the great facts and elements of the subject before the reader.

Looking more at large into the subject, we shall find our English law to recognise from the earliest periods three great classes of prisoners—the debtor, the accused criminal, and the convicted criminal. It is clear that the imprisonment of each proceeds upon totally different principles, and there are even subdivisions of these classes of some importance. We imprison the man suspected of crime, for instance *solely* to secure his appearance on the day appointed for trial; it is matter of necessity, and the law has therefore only recourse to it where no adequate substitute by way of security can be provided; for, under the imputation of the heaviest crimes, it lodges a power with its higher officers of estimating and accepting such substitute. It is agreed, says Blackstone, that the Court of King's Bench, or any judge thereof in time of vacation, may bail for any crime whatsoever, be it treason, murder, or any other offence, according to the circumstances of the case. 4 Com. p. 299. We imprison the convict for punishment; and the debtor in execution partly for punishment of the fraud which he is presumed or proved to have committed on his creditor, and partly as a mode of compelling him to produce or render available for the discharge of his debts that property which cannot be directly reached. Though, however, the objects which the law has in view, in these three cases of imprisonment, are thus various, and though the duties which are incurred in consequence toward the unhappy subjects of it will naturally have proportionate varieties, yet in some respects they will be entirely the same; certain things are proper, certain things necessary in every prison, and for every prisoner.

In the first place a universal requisite is security; an insecure prison is a solecism in terms; on this point it would not be necessary to say a word, if all people were as well agreed in respect of the means as of the end. The ancient practice was to rely more upon fetters and manacles, than the walls of the prison or the vigilance of the gaoler; but the new prison bill enacts that 'no prisoner shall be put in irons by the keeper of any prison except in cases of urgent and absolute necessity, and the particulars of every such case shall be forthwith entered in the keeper's journal, and notice forthwith given thereof to one of the visiting justices; and the keeper shall not continue the use of irons on any prisoner longer than four days, without an order in writing from a visiting justice specifying the cause thereof.'—s. x. reg. 12. No one can doubt the propriety of such a regulation—we are satisfied that fettering the debtor or the accused criminal as a matter of course was always illegal; how far it stood within the protection of the law in the case of the convict seems not so clear. The common argument, that it is unlawful to exceed the terms of a sentence, and that a sentence of imprisonment says nothing of fetters, proves

nothing; the sentence says nothing of many other prison privations, the legality of which cannot be doubted; it is general in its terms, and includes every circumstance which goes to make up the idea of legal imprisonment, so that the question always comes round to what is legal imprisonment. Waiving, however, a legal discussion, which the statute just cited renders unnecessary, we agree with the warmest opposers of the practice that it was always inexpedient to iron even the convict, unless his own refractoriness or desperation made it necessary. Observation too will warrant us in going a step farther, and expressing an opinion that the frequent necessity for the use of fetters almost amounts to proof of some mismanagement in the prison in which it shall exist. It is not the least merit in the prison bill that, by the restrictions imposed on the use of them, greater care and more skillful management become necessary on the part of governors of prisons.

The next requisite of all prisons clearly is that they should be healthy and clean. Air and exercise, food and clothes such as are necessary for the sustentation of health, together with medicine and attendance when sick, stand upon the same principle; except in that short and awful interval which precedes execution, and which is spent in preparation for it, there can be no time or circumstance under which any prisoner may not demand all those things which are ordinarily necessary for the preservation of life. We are aware that, in some of these last particulars, we may be thought to push the claims of the prisoner farther than justice requires; there are those who deny in the whole any claim of right which he can set up to food, clothing or lodging, and others who, admitting the abstract right, would yet practically reduce the quantity and quality below the scale implied in our remarks. It is more difficult to decide, whether, in particular instances, the introduction of more generous food or greater comforts should be allowed according to other considerations than those of health; in other words, whether the ability of the party to purchase, or his industry and good behaviour, should procure him luxuries denied to his fellow-prisoners in general. There is long practice, and high authority in the favor of the affirmative; with regard to debtors, it is, we believe, universally allowed to them to procure food without any food or liquor, subject only to certain prohibitions and regulations; and as to prisoners who labor, it has long been the custom, in some of our best regulated prisons, to stimulate industry by allowing a portion of the profits earned by the prisoner to be spent by him in this way.

The prison bill steers a middle course, allowing the introduction of food, not extravagant or luxurious, to debtors, or accused criminals, who receive no allowance from the county; and prohibiting it in the case of convicts, except under the permission of the visiting justices, or the regulations of the quarter-sessions.—s. x. reg. 14 and 15. Mr. Holford asserts that, 'the prisoners whose labor is most productive in the Penitentiary at Millbank, are not those whose behaviour entitles them to most consid-

ration, or of whose eventual restoration with credit to society the chaplain entertains the most favorable expectation.' p. 53. It is obvious, indeed, that the system of allowing them in all cases a participation in the fruit of their labors, must be unfavorable in many respects to the reformation of prisoners; its tendency being to confirm in the habit of looking to immediate self-indulgence, as the motive for action, men who have already found that motive too strong for their prudence or their conscience. Such a system seems to us to be founded upon a mistaken view of many of the objects of imprisonment. Howard found one great evil of our prisons to be a total want of employment, and he described in very fascinating colors the appearance which those presented in which the prisoners were fully employed. Undoubtedly a salutary change was produced—the giving all prisoners an opportunity of working, and compelling some to work, were among the most efficient causes of the great improvement which has taken place in our prisons; but it is to mistake the means for the end, when prisons are estimated by the cheerful activity of the laborers, and the quantity of productive labor within their walls. A prison ought still to be a place of terror to those without, of punishment to those within; let us reform criminals if we can—it is a great and glorious object, uncertain in the result, but imperative in the obligation. Punishment, however, is certain; and it is one mode of punishment, severely felt by those who have led a life of self-indulgence, but unattended with any cruelty, to tie them down to a coarse, uniform diet. Two exceptions may be urged: we may be asked whether we would extend the rule to persons of the higher ranks of life, and convicted of offences such as libel, provocations to duel, &c., which ordinarily are understood to carry with them less of moral turpitude. We confess that we can see no reason for not carrying the rule so far; the health of the party must of course always be the first object, and it would be for the medical attendant to see that no change of habit was made so violent in its nature as to affect it; but rank or education ought not to lighten punishment; if they make the feelings more susceptible to an equal infliction, it must be remembered also that the moral restraint and social obligation were stronger, and that the violation of them merits a severer suffering. The case of debtors also may be here pressed; but, health being secured, we cannot say that there appears to us any injustice in subjecting them also to the mortification of their appetite. Every debtor in execution either can or cannot pay his creditor; if he can, and will not, preferring to spend in self-indulgence the substance which in truth belongs to his creditor, it is well that he should be prevented from gratifying so unjust a desire; if he cannot, then he is supposed to be in a state of destitution, and the prison allowance must be a relief to him.

We have been induced, from the importance of the subject, to hazard some repetition, after our extract from Mr. Buxton with regard to these rights of prisoners. But, waiving many minor, yet important considerations, such as the difficulty of preserving uniform discipline, or

consistent details in a prison, in which the prisoners are allowed a different scale of diet, varying according to their own fancies, we come to these conclusions—that all have a right to be fed, and that all should be confined to the same prison allowance, qualifying the rule in individual cases according to the directions of the medical officer of the prison; and, if any other variation be allowed, we should prefer the indulgence being granted as the reward of orderly behaviour, to the regulating it by the amount of the prisoner's earnings.

The prisoner, of whatever description, has further claims to be protected from the corruption of bad society, and to be afforded an opportunity of performing uninterruptedly his religious duties.

Upon this head, of religious instruction and attendance, the prison bill has made a most important improvement in our criminal law. The duties of the chaplain are marked out with fullness and precision; the inmates of a gaol require, and they will henceforward receive, even more minute and constant attendance than the poor of the most favored parishes. He is made one of the most responsible and important officers of the prison; his salary is regulated, not extravagantly and yet liberally, with reference to the number of prisoners; a pension is provided for him in case of sickness, age, or infirmity; and the situation may be now made to present, if the magistracy are disposed to act in hearty accordance with the legislature, which we do not doubt, an ample, and not undesirable field for the exertion of zeal and talent in the Christian ministry. We have now stated, though not so concisely as we could have wished, the claims which we conceive prisoners of every description seem to us to have on the country: on the other hand, the rights which the country has over the inmates of its prisons will vary with the causes which place them there; but there are certain general powers which it may justly exercise in all cases.

It has a right to general order and decency within the prison; and for this purpose it may enforce proper discipline on every individual, and reasonably punish the breach of it. For the same purpose, it may regulate the prison hours, and the mode of employment of all the prisoners, even of those whom it has no power of compelling to labor, restricting it to such kinds of work as may be fittingly and wholesomely carried on within the walls, directing the sale of the produce, and apportioning the earnings in such manner as may best accord with the regulations of the place; it has a right to restrain the intercourse of the prisoners with each other, and to exercise an entire control over the visits of friends from without.

This last is a matter of importance, and of some difficulty; on the one hand, to deny even to the convicted prisoner all intercourse with his family and friends is not merely a measure of great severity, requiring some clear advantage as its justification, but, in our opinion, is to throw away a powerful mean, under proper regulations, of encouragement and moral improvement;—on the other hand, it cannot be doubted that great injury is done to the discipline of the prison, and

to the public, by an indiscriminate admission of visitors. A prison whose gates are perpetually admitting idle spectators will necessarily lose half its terrors. Those salutary ideas of loathsomeness and misery which men associate with a gaol, and which naturally tend to the prevention of crime, cannot fail to be much weakened by a sight of the cleanliness and order, the decent apparel and seeming comfort, which are found within the walls; men commonly judge from what they see, and make little account of what they do not see, the solitude and wearisomeness, the hard fare and hard labor of the prisoners. They will therefore leave the prison, believing that the sufferings of confinement have been exaggerated; and what they believe they may act upon; or at least they will eagerly circulate the statement.

The notion of a fee on admission is rather strange to our feelings, but we take for granted that that is not the only requisite. The regulations of the Prison Bill, as we understand them, put the matter on the right footing; prisoners only committed for trial are to receive visits at proper times and under proper restrictions, settled by the governor, or visiting justices; and convicts only under such rules and regulations as may be determined on at the quarter-sessions.

In this part of our subject one more topic remains to be discussed, but of great importance, the employment of the prisoners. It is obvious that this can have reference only to those who are confined upon suspicion, or for punishment of crimes; but with regard to each of these classes great difference of opinion prevails as to the principle and the mode of enforcing it. The law and common sense agree in making a wide distinction between prison employment and hard labor. The former is undoubtedly desirable for all prisoners, and every proper and rational inducement should be held out to them to engage in it—inducements which experience warrants us in saying will scarcely ever fail of success. It is a question, however, to which late circumstances have attached some consequence, whether there is any legal power, directly or indirectly, to compel persons, either untried or sentenced simply to imprisonment, to labor. The general practice, we believe, varies much in this respect between these two classes; in a great, perhaps the greater number of prisons, in which the reformation of the prisoner is attempted, a convict sentenced to imprisonment only is directly or indirectly compelled to work as a part of prison discipline; but in scarcely any is the same rule observed with regard to persons only committed for trial. It would be as difficult, perhaps, to find a direct authority in law for compelling the convict to work as the untried prisoner; but many of the reasons which apply with great cogency against compulsion on the latter certainly do not exist in respect of the former. Where a man has been proved guilty of a crime against society, for which it is thought necessary to punish him by seclusion, society has a right to subject him to such discipline as may be thought likely to make him harmless to her interests when he shall be restored to liberty: this would warrant direct compulsion. And, as to the indirect compulsion of withholding

... by ... of the cau ... true ... of the ... of the ... mode of earning ... presumes to be ... because it ... appearance at ... reasons in favor of his ... or inter- ... we believe, has not ... ground on which it ... the enforcement of dis- ... that must be preserved, ... prisoner. We are not, ... to deny, that for riot or dis- ... an unconvicted criminal may, ... be treated as a con- ... character he comes, he is ... to submit to the laws of the place, ... with the peace and good order ... But this is an argument which will ... the compulsory labor of a peaceable ... but slothful or even obstinate pri- ...

With respect to hard labor as a useful mode of punishment and correction there cannot well be much difference of opinion. When, however, this subject first attracted the public attention, the benevolent individuals in different counties who took the largest share in directing the measure, 'seldom ventured (as Sir George Paul says) to turn their eyes from income and profit to a county rate; every house of correction was to become a busy manufactory, and to maintain itself.' Much as we are advocates for industry in prisoners, and economy of public money, we think both may be purchased too dearly; and we are not sorry, we confess, that in almost every place in which the manufactory-system has been tried it has proved, if not a failing concern on the whole, yet certainly far less profitable than was expected. We do not, of course, mean to condemn all profitable labor of the prisoners, but we are anxious that it should never be the primary object; in truth the best economy is in that system which produces the fewest recommitments, and prevents the most crimes.

The tread-wheel is an invention which has certainly been exposed to most unfounded attacks, and perhaps been praised far beyond its real merits, but which we do not hesitate to pronounce an important instrument of prison discipline. The fifth Report of the Society for the Improvement of Prison Discipline is before us, and it is in no part more sensible or instructive than in what it communicates on this subject; on which, as might be expected, a great deal of ignorance prevails: and although almost every tread-wheel varies practically in the quantity of labor which it imposes, and consequently in a great measure in the effect which it is calculated to produce, the machine is praised or blamed as if it were one thing, the same in every prison. The labor of the wheel it should be remembered is by ascending steps, and the amount of ascent made must

depend on the number of hours employed, the velocity of the wheel (which, when there is no fly-regulator, will also vary with the number of men on it at the same time), the distance from step to step, and the proportion of those out of each gang who are on the wheel at one time, to those who are off. It is obvious, therefore, that what may be very true of one wheel may be entirely false of another. Thus, to select a few instances out of many, at Lewes each prisoner works at the rate of 6600 feet in ascent per day; at Ipswich, 7450; at St. Albans, 8000; at Bury, 8950; at Cambridge, 10,175; at Durham, 12,000; at Brixton, Guildford, and Reading the summer rate exceeds 13,000; while at Warwick the summer rate will be 17,000 feet in ten hours, if the present resolution be adhered to; which, upon reflection, we are quite sure it never will, as no strength could long endure such labor. In addition to these immense differences, those of the dietaries must also be taken into the account. Our remarks shall be confined to the principle of this machine considered generally.

Assuming then that it will be used with discretion and humanity, we will state what we conceive to be its disadvantages and advantages. In the first place, it is inapplicable to prisoners under long confinements; there is in it at once so much irksomeness, sameness, and real fatigue, that, after subduing a stubborn spirit, we should be afraid, with long continuance, it might go on almost to stupify the intellect; for, while the body labors, the mind is wholly unemployed. But, even if this be thought an extreme apprehension, it must be admitted that it not only teaches no trade or occupation by which a livelihood may afterwards be earned, but must in some measure render the parties less fit for manual labor by disuse of those parts and muscles of the body which are employed in handicraft trades. Making these deductions, of which the latter is capable of an answer when we limit the use of the tread-wheel to confinements of a short duration, in which a trade could not be learned, nor the body lose its aptness for one to which it had been accustomed, the advantages seem to be, that the tread-wheel is labor indeed, dreaded in the prospect, irksome in endurance, and remembered with disgust; that it has never failed to subdue the most turbulent spirit; that, requiring no instruction, every man who can walk may be set upon it from the moment that his sentence is pronounced; that he cannot avoid his portion of labor, the wheel turning by weight and not by exertion; that the occupation is so unceasing that conversation between the prisoners is much restrained; that it may without injury be employed for many hours in the day, and with a very little expense in the open air; that it affords great advantages for inspection, and thereby much facilitates the duties of the governor. Under these impressions, and with these restrictions, we cannot but say that we shall be glad to hear of the erection of a tread-wheel in every considerable prison in the country.

We conclude in the words of the Fifth Report:—'Of the progress of information and of public feeling, within these few years, on the subject of prison discipline, the former Reports

of this Society bear ample testimony. Parliamentary interference, the exertions of the magistracy, and diligence of enquiry, have combined to bring the subject prominently before the public mind. The principles on which punishments are enforced have undergone the deliberate investigation of the legislature. It is the general feeling that the unconvicted should be treated with as much lenity as is compatible with the safe custody of his person, and the good order of the prison; whilst, upon those on whom the law inflicts punishment, a salutary system of discipline ought to be enforced; that, in the treatment of the convicted, no severity should be allowed that is not warranted by the laws, nor consistent with justice; that the prevention of crime is the ultimate object of imprisonment, and that to attain this end it is necessary to insure the reformation, as well as the punishment of the prisoner. Uniform severity, it is generally admitted, hardens the offender, and prepares him for the perpetration of further crimes. It is necessary not only to inspire terror, but to kindle hope—to impress upon the mind not only a sense of guilt, but the love of virtue; and to implant those principles, and cherish those feelings, which religion only can impart.

The separate discipline of the common gaol, the House of Correction, and the Hulk or Penitentiary, might here be adverted to; but on this subject we can only refer to the Quarterly Review, No. LX., and the Reports of the Society for the Improvement of Prison Discipline.

**PRISTINE**, *adj.* Lat. *pristinus*. First; ancient; original.

Now their *pristine* worth

The Britons recollect. *Philips.*  
 This light being trajected only through the parallel surfaces of the two prisms, if it suffered any change by the refraction of one superficies, it lost that impression by the contrary refraction of the other superficies, and so, being restored to its *pristine* constitution, became of the same nature and condition as at first. *Newton.*

**PRISTIS**, in ichthyology, the sawfish, is generally considered as a species of the squalus, a shark genus, comprehending under it several varieties. Mr. Latham, however, is of opinion that it ought to be considered as a distinct genus itself, and that the characteristics of the several varieties are sufficient to constitute them distinct species. He ranks it as a genus belonging to the order of amphibia nantes. Its characters are these: a plain long snout, with spines growing like teeth out of both edges; four or five spiracula, or breathing apertures, in the sides of the neck: the body is oblong and almost round, with a tough coriaceous skin; the mouth is situated in the lower part of the head; and the nostrils, before the mouth, are half covered with a membranaceous lobe; behind the eyes are two oval scales; the ventral fins approach one another, and in the male are placed about the organs of generation; there are no fins at the anus. Of this genus our author enumerates five species:

1. *P. antiquorum*. The head is rather flat at top; the eyes large, with yellow irides; behind each is a hole, which some have supposed may be an organ of hearing. The mouth is well

furnished with teeth, but they are blunt, serving rather to bruise its prey than to divide it by cutting. Before the mouth are two foramina, supposed to be the nostrils. The rostrum, beak, or snout, is in general about one-third of the total length of the fish, and contains in some eighteen, in others as far as twenty-three or twenty-four spines on each side; these are very stout, much thicker at the back part, and channelled, inclining to an edge forwards. The fins are seven in number—viz. two dorsal, placed at some distance from each other—two pectoral, taking rise just behind the breathing-holes, which are five in number—two ventral, situated almost underneath the first dorsal—and, lastly, the caudal, occupying the tail both above and beneath, but longest on the upper part. The general color of the body is a dull gray, or brownish, growing paler as it approaches the belly, where it is nearly white.

2. *P. cirratus*, of which, continues our author, we have only met with one specimen, which was brought from Port Jackson in New Holland. It is a male, and the total length about forty inches: the snout, from the tip of it to the eye, eleven: the spines widely different from any of the others; they are indeed placed, as usual, on the edge, but are continued on each side even beyond the eyes. The longer ones are slender, sharp, somewhat bent, and about twenty in number, and between these are others not half the length of the primal ones, between some three or four, between others as far as six; and in general the middle one of these smaller series is the longest: besides these a series of minute ones may be perceived beneath, at the very edge. In the snout, likewise, another singularity occurs:—about the middle of it on each side, near the edge, arises a flexible ligamentous cord, about three inches long, like the beards at the mouth of some of the gadus or cod genus, and as pliant in the recent state. The color of the fish is a pale brown: the breathing apertures four: the mouth furnished with five rows of minute, but very sharp teeth.

3. *P. cuspidatus*. Of this our author has seen only two specimens, the one about a foot and a half in length, and the other more than two feet and a half. In both of these were twenty-eight spines on each side; but the distinguishing feature is the spines themselves, being particularly flat and broad, and shaped at the point more like the lancet used by surgeons in bleeding, than any other figure.

4. *P. microdon*. Of this species the total length is twenty-eight inches, the snout occupying ten; from the base of this to that of the pectoral fins four inches; between the pectoral and ventral fins six. The two dorsal fins occupy nearly the same proportions in respect to each other; but the hinder one is the smallest, and all of them are greatly hollowed out at the back part, much more so than in the two first species. The snout differs from that of every other in several particulars; it is longer in proportion, being more than one-third of the whole fish. The spines do not stand out from the sides more than a quarter of an inch, and from this circumstance seem far less capable of doing injury than any other species yet known.



sustenance from him if he refuses to earn it by labor, there can be no injustice in this, for he can have no positive claim to maintenance; it is true that he has been withdrawn from his trade or occupation, but that is a necessary part of the punishment of his crime, the forfeiture of the means of resorting to his former mode of earning a livelihood. But with a man committed only on suspicion, whom the law still presumes to be innocent, and deprives of liberty only because it sees no other mode of securing his appearance at the day of trial, all the reason is in favor of his immunity from every other privation or interference. Direct compulsion, we believe, has not been attempted; the only ground on which it could be put would be the enforcement of discipline; and undoubtedly that must be preserved, if necessary, over every prisoner. We are not, therefore, disposed to deny, that for riot or disorderly behaviour an unconvicted criminal may, from the necessity of the case, be treated as a convict; in whatever character he comes, he is bound so far to submit to the laws of the place, as not to interfere with the peace and good order of others. But this is an argument which will never justify the compulsory labor of a peaceable and orderly, but slothful or even obstinate prisoner.

With respect to hard labor as a useful mode of punishment and correction there cannot well be much difference of opinion. When, however, this subject first attracted the public attention, the benevolent individuals in different counties who took the largest share in directing the measure, 'seldom ventured (as Sir George Paul says) to turn their eyes from income and profit to a county rate; every house of correction was to become a busy manufactory, and to maintain itself.' Much as we are advocates for industry in prisoners, and economy of public money, we think both may be purchased too dearly; and we are not sorry, we confess, that in almost every place in which the manufactory-system has been tried it has proved, if not a failing concern on the whole, yet certainly far less profitable than was expected. We do not, of course, mean to condemn all profitable labor of the prisoners, but we are anxious that it should never be the primary object; in truth the best economy is in that system which produces the fewest recommittals, and prevents the most crimes.

The tread-wheel is an invention which has certainly been exposed to most unfounded attacks, and perhaps been praised far beyond its real merits, but which we do not hesitate to pronounce an important instrument of prison discipline. The fifth Report of the Society for the Improvement of Prison Discipline is before us, and it is in no part more sensible or instructive than in what it communicates on this subject; on which, as might be expected, a great deal of ignorance prevails: and although almost every tread-wheel varies practically in the quantity of labor which it imposes, and consequently in a great measure in the effect which it is calculated to produce, the machine is praised or blamed as if it were one thing, the same in every prison. The labor of the wheel it should be remembered is by ascending steps, and the amount of ascent made must

depend on the number of hours employed, the velocity of the wheel (which, when there is no fly-regulator, will also vary with the number of men on it at the same time), the distance from step to step, and the proportion of those out of each gang who are on the wheel at one time, to those who are off. It is obvious, therefore, that what may be very true of one wheel may be entirely false of another. Thus, to select a few instances out of many, at Lewes each prisoner works at the rate of 6600 feet in ascent per day; at Ipswich, 7450; at St. Albans, 8000; at Bury, 8950; at Cambridge, 10,175; at Durham, 12,000; at Brixton, Guildford, and Reading the summer rate exceeds 13,000; while at Warwick the summer rate will be 17,000 feet in ten hours, if the present resolution be adhered to; which, upon reflection, we are quite sure it never will, as no strength could long endure such labor. In addition to these immense differences, those of the dietaries must also be taken into the account. Our remarks shall be confined to the principle of this machine considered generally.

Assuming then that it will be used with discretion and humanity, we will state what we conceive to be its disadvantages and advantages. In the first place, it is inapplicable to prisoners under long confinements; there is in it at once so much irksomeness, sameness, and real fatigue, that, after subduing a stubborn spirit, we should be afraid, with long continuance, it might go on almost to stupify the intellect; for, while the body labors, the mind is wholly unemployed. But, even if this be thought an extreme apprehension, it must be admitted that it not only teaches no trade or occupation by which a livelihood may afterwards be earned, but must in some measure render the parties less fit for manual labor by disuse of those parts and muscles of the body which are employed in handicraft trades. Making these deductions, of which the latter is capable of an answer when we limit the use of the tread-wheel to confinements of a short duration, in which a trade could not be learned, nor the body lose its aptness for one to which it had been accustomed, the advantages seem to be, that the tread-wheel is labor indeed, dreaded in the prospect, irksome in endurance, and remembered with disgust; that it has never failed to subdue the most turbulent spirit; that, requiring no instruction, every man who can walk may be set upon it from the moment that his sentence is pronounced; that he cannot avoid his portion of labor, the wheel turning by weight and not by exertion; that the occupation is so unceasing that conversation between the prisoners is much restrained; that it may without injury be employed for many hours in the day, and with a very little expense in the open air; that it affords great advantages for inspection, and thereby much facilitates the duties of the governor. Under these impressions, and with these restrictions, we cannot but say that we shall be glad to hear of the erection of a tread-wheel in every considerable prison in the country.

We conclude in the words of the Fifth Report:—'Of the progress of information and of public feeling, within these few years, on the subject of prison discipline, the former Reports

of this Society bear ample testimony. Parliamentary interference, the exertions of the magistracy, and diligence of enquiry, have combined to bring the subject prominently before the public mind. The principles on which punishments are enforced have undergone the deliberate investigation of the legislature. It is the general feeling that the unconvicted should be treated with as much lenity as is compatible with the safe custody of his person, and the good order of the prison; whilst, upon those on whom the law inflicts punishment, a salutary system of discipline ought to be enforced; that, in the treatment of the convicted, no severity should be allowed that is not warranted by the laws, nor consistent with justice; that the prevention of crime is the ultimate object of imprisonment, and that to attain this end it is necessary to insure the reformation, as well as the punishment of the prisoner. Uniform severity, it is generally admitted, hardens the offender, and prepares him for the perpetration of further crimes. It is necessary not only to inspire terror, but to kindle hope—to impress upon the mind not only a sense of guilt, but the love of virtue; and to implant those principles, and cherish those feelings, which religion only can impart.

The separate discipline of the common gaol, the House of Correction, and the Hulk or Penitentiary, might here be adverted to; but on this subject we can only refer to the Quarterly Review, No. LX., and the Reports of the Society for the Improvement of Prison Discipline.

**PRISTINE**, *adj.* Lat. *pristinus*. First; ancient; original.

Now their *pristine* worth

The Britons recollect.

*Philips.*

This light being trajected only through the parallel superficies of the two prisms, if it suffered any change by the refraction of one superficies, it lost that impression by the contrary refraction of the other superficies, and so, being restored to its *pristine* constitution, became of the same nature and condition as at first.

*Newton.*

**PRISTIS**, in ichthyology, the sawfish, is generally considered as a species of the squalus, or shark genus, comprehending under it several varieties. Mr. Latham, however, is of opinion that it ought to be considered as a distinct genus itself, and that the characteristics of the several varieties are sufficient to constitute them distinct species. He ranks it as a genus belonging to the order of amphibia nantes. Its characters are these: a plain long snout, with spines growing like teeth out of both edges; four or five spiracula, or breathing apertures, in the sides of the neck: the body is oblong and almost round, with a tough coriaceous skin; the mouth is situated in the lower part of the head; and the nostrils, before the mouth, are half covered with a membranaceous lobe; behind the eyes are two oval noles; the ventral fins approach one another, and in the male are placed about the organs of generation; there are no fins at the anus. Of this genus our author enumerates five species:

1. *P. antiquorum*. The head is rather flat at top; the eyes large, with yellow irides; behind each is a hole, which some have supposed may lead to an organ of hearing. The mouth is well

furnished with teeth, but they are blunt, serving rather to bruise its prey than to divide it by cutting. Before the mouth are two foramina, supposed to be the nostrils. The rostrum, beak, or snout, is in general about one-third of the total length of the fish, and contains in some eighteen, in others as far as twenty-three or twenty-four spines on each side; these are very stout, much thicker at the back part, and channelled, inclining to an edge forwards. The fins are seven in number—viz. two dorsal, placed at some distance from each other—two pectoral, taking rise just behind the breathing-holes, which are five in number—two ventral, situated almost underneath the first dorsal—and, lastly, the caudal, occupying the tail both above and beneath, but longest on the upper part. The general color of the body is a dull gray, or brownish, growing paler as it approaches the belly, where it is nearly white.

2. *P. cirratus*, of which, continues our author, we have only met with one specimen, which was brought from Port Jackson in New Holland. It is a male, and the total length about forty inches: the snout, from the tip of it to the eye, eleven: the spines widely different from any of the others; they are indeed placed, as usual, on the edge, but are continued on each side even beyond the eyes. The longer ones are slender, sharp, somewhat bent, and about twenty in number, and between these are others not half the length of the primal ones, between some three or four, between others as far as six; and in general the middle one of these smaller series is the longest: besides these a series of minute ones may be perceived beneath, at the very edge. In the snout, likewise, another singularity occurs:—about the middle of it on each side, near the edge, arises a flexible ligamentous cord, about three inches long, like the beards at the mouth of some of the gadus or cod genus, and as pliant in the recent state. The color of the fish is a pale brown: the breathing apertures four: the mouth furnished with five rows of minute, but very sharp teeth.

3. *P. cuspidatus*. Of this our author has seen only two specimens, the one about a foot and a half in length, and the other more than two feet and a half. In both of these were twenty-eight spines on each side; but the distinguishing feature is the spines themselves, being particularly flat and broad, and shaped at the point more like the lancet used by surgeons in bleeding, than any other figure.

4. *P. microdon*. Of this species the total length is twenty-eight inches, the snout occupying ten; from the base of this to that of the pectoral fins four inches; between the pectoral and ventral fins six. The two dorsal fins occupy nearly the same proportions in respect to each other; but the hinder one is the smallest, and all of them are greatly hollowed out at the back part, much more so than in the two first species. The snout differs from that of every other in several particulars; it is longer in proportion, being more than one-third of the whole fish. The spines do not stand out from the sides more than a quarter of an inch, and from this circumstance seem far less capable of doing injury than any other species yet known.

5 *P. pectinatus*. This, with the first species, grows to the largest size of any that have yet come under the inspection of the naturalist, some specimens measuring fifteen feet in length. The *pectinatus* differs from the *P. antiquorum* in having the enout more narrow in proportion at the base, and the whole of it more slender in all its parts; whereas the first is very broad at the base, and tapers considerably thence to the point. The spines on each side also are longer and more slender, and vary from twenty-five to thirty-four in the different specimens.

PRITH'EE. A corruption of pray thee, or I pray thee.

Well, what was that scream for, I *prith'ee*?

*L'Estrange.*

Alas! why comest thou at this dreadful moment, To shock the peace of my departing soul?  
Away! I *prith'ee* leave me!

*Rowe's Jane Shore.*

PRIVASET, a small town in the department of the Dordogne, France, remarkable for the grotto of Miremont, which is at a little distance from it, and which is considered as the finest in the kingdom. It is situated about two-thirds up an extremely barren hill; its depth from the entrance to the extremity of the largest branch is 545 fathoms, and the extent of all its ramifications 2170 fathoms. If the different windings of the grotto and those which the traveller usually makes in order to observe the objects attached to the sides, were reckoned, they would amount to more than six miles; and it would be dangerous to adventure far into it, without the assistance of a guide accustomed to the place.

PRIVATE, *adj.* & *n. s.* } Lat. *privatus*. Se-  
PRIVACY, *n. s.* } cret; reserved; con-  
PRIVADO, } cealed; alone; par-  
PRIVATEER', *n. s.* & *v. a.* } ticular: Shakspeare  
PRIVATELY, *adv.* } uses the noun sub-  
PRIVATENESS, *n. s.* } stantive for a private

message: privacy and privateness mean secrecy; retirement; state of being concealed or unexposed; it is used, by Arbuthnot improperly, for privacy: *privado* is adopted from the Spanish by Bacon for a private friend: a privateer is a vessel fitted out by private individuals against a public enemy: to privateer is to fit out or conduct such a vessel: privately follows the senses of private, *adj.*

And, as he sat upon the Mount of Olives, the disciples came unto him *privately*. *Matthew xxiv. 3.*

To correct the particular faults of *private* men, would be a work too infinite; yet some there be of that nature, that though they be in *private* men, yet their evil reacheth to a general hurt, as the extortion of sheriffs, and their sub-sheriffs and bailiffs, the corruption of victuallers, &c. *Spenser.*

When publick consent of the whole hath established any thing, every man's judgment, being thereunto compared, were *private*, howsoever his calling be to some kind of public charge; so that of peace and quietness there is not any way possible, unless the probable voice of every entire society or body politic overrule all *private* of like nature in the same body. *Hooker's Preface.*

You shall go with me;  
have some *private* schooling for you both.

*Shakspeare.*

What infinite heartease must kings neglect,  
That *private* men enjoy? and what have kings,  
That *private* have not too, save ceremony? *Id.*

His *private* with me of the dauphin's love,  
Is much more general than these lines impart. *Id.*

There, this night,

We'll pass the business *privately* and well. *Id.*  
Ambassadors attending the court in great number, he did content with courtesy, reward, and *privateness*. *Bacon.*

The lady Brampton, an English lady, embarked for Portugal at that time, with some *privado* of her own. *Id.*

He drew him into the fatal circle from a resolved *privateness*, where he beat his mind to a retired course. *Wotton.*

Peter was but a *private* man, and not to be any way compared with the dukes of his house.

*Peucham of Antiquities.*

Even the *privatetest* person may shine forth in good counsel. *Bp. Hall.*

My end being *private*, I have not expressed my conceptions in the language of the schools. *Digby.*

Fancy retires

Into her *private* cell, where nature rests. *Milton.*  
Clamour our *privacies* uneasy make,  
Birds leave their nests disturbed, and beasts their haunts forsake. *Dryden.*

Dare you,

A *private* man, presume to love a queen? *Id.*  
*Private*, or secret prayer, is that which is used by a man alone apart from all others. *Duty of Man.*

Her sacred *privacies* all open lie,

To each profane enquiring vulgar eye. *Rouse.*  
You see Frog is religiously true to his bargain, scorns to hearken to any composition, without your *privacy*. *Arbuthnot.*

In *private* grieve, but with a careless scorn;  
In publick seem to triumph, not to mourn.

*Granville.*

The first principles of Christian religion should not be forced with school points and *private* tenets. *Saunderson.*

He is at no charge for a fleet, further than providing *privateers*, wherewith his subjects carry on a piratical war at their own expense.

*Swiji's Miscellanies.*

Fame, not contented with her broad highway,  
Delights, for change, through *private* paths to stray. *Harris.*

PRIVATEERS are a kind of private men of war, the persons concerned wherein administer at their own costs a part of a war, by fitting out these ships of force, and providing them with all military stores; and they have, instead of pay, leave to keep what they take from the enemy, allowing the admiral his share, &c. Privateers may not attempt any thing against the laws of nations; as to assault an enemy in a port or haven, under the protection of any prince or republic, whether he be friend, ally, or neutral; for the peace of such places must be inviolably kept; therefore, before a commission shall be granted to any privateer, the commander is to give security, if the ship be not above 150 tons, in £1500, and, if the ship exceeds that burden, in £3000, that they will make satisfaction for all damages which they shall commit in their courses at sea contrary to the treaties with any state, on pain of forfeiting their commissions; and the ship is made liable. Besides these private commissions, there are special commissions for privateers, granted to commanders of ships, &c., who receive pay, are under marine discipline, and, if they do not obey their orders,

may be punished with death. In case we are at war with more potentates than one, privateers must have commissions for acting against each of them; otherwise, if a captain, carrying only one against the Danes, should in his prize meet with and take a Frenchman, this prize is not good, but would be taken from him by any man of war he met, and could not be condemned (for him) in the admiralty. Ships taken by privateers were to be divided into five parts; four parts whereof go to the persons interested in the privateer, and the fifth to his majesty. By statute the lord admiral, or commissioners of the admiralty, may grant commissions to commanders of privateers for taking ships, &c., which being adjudged prizes, and the tenth part paid to the admiral, &c., wholly belong to the owners of the privateers and the captors, in proportions agreed on between themselves.

**PRIVATION, n. s.** } Fr. *privation*; Lat. }  
**PRIVATIVE, adj. & n. s.** } *privatio*. Removal or }  
**PRIVATIVELY, adv.** } destruction of any }  
 thing or quality; removal from office: privative is causing removal, obstruction, or absence of something; that of which the absence of some other thing forms the chief idea: privatively is negatively.

If part of the people or estate be somewhat in the election, you cannot make them nulls or cyphers in the *privation* or translation. *Bacon*.

Harmonical sounds and discordant sounds are both active and positive, but blackness and darkness are indeed but *privatives*, and therefore have little or no activity; somewhat they do contrastate, but very little. *Id. Natural History*.

For, what is this contagious sin of kind, But a *privation* of that grace within? *Davies*.  
 The duty of the new covenant is set down, first *privatively*, not like that of Mosaic observances external, but positively, laws given into the minds and hearts. *Hammond*.

The very *privative* blessings, the blessings of immunity, safeguard, liberty, and integrity, which we enjoy, deserve the thanksgiving of a whole life. *Taylor*.

So bounded are our natural desires, That wanting all, and setting pain aside, With bare *privation* sense is satisfied. *Dryden*.  
 After some account of good, evil will be known by consequence, as being only a *privation* or absence of good. *South*.

A *privation* is the absence of what does naturally belong to the thing, or which ought to be present with it; as when a man or horse is deaf or dead, or a physician or divine unlearned; these are *privations*. *Watts's Logick*.

**PRIVERNUM**, a town of the Volsci, in Latium, east of Setia. Having revolted from the Romans, their ambassadors were asked, what punishment they themselves thought they deserved? They answered what those deserve who deem themselves worthy of liberty. Being asked, should the punishment be remitted, what peace was to be expected with them? they replied, If you grant a favorable peace, you may hope to have it sincere and lasting; but, if a bad one, you may expect it of short continuance. The Romans were so far from being displeased, that by a vote of the people they had the freedom of the city granted them. The town is now called **PIPERNO**. See that article.

**PRIVET**, in botany. See **LIGUSTRUM**.

**PRIVET, EVERGREEN**. See **RHAMNUS**.

**PRIVILEGE, n. s. & v. a.** Fr. *privilege*; Lat. *privilegium*. Peculiar advantage or right; immunity: to invest with peculiar rights or immunities.

The court is rather deemed as a *privileged* place of unbridled licentiousness, than as the abiding of him who, as a father, should give a fatherly example. *Sidney*.

Here's my sword,  
 Behold it is the *privilege* of mine honours,  
 My oath, and my profession. *Shakspeare*.  
 He took this place for sanctuary,  
 And it shall *privilege* him from your hands. *Id.*

This place  
 Doth *privilege* me, speak what reason will. *Daniel*.

He claims his *privilege*, and says 'tis fit,  
 Nothing should be the judge of wit, but wit. *Denham*.

He went  
 Invisible, yet stayed, such *privilege*  
 Hath omnipresence. *Milton*.  
 Many things are by our laws *privileged* from tythes,  
 which by the canon law are chargeable. *Hale*.

When the chief captain ordered him to be scourged uncondemned, he pleads the legal *privilege* of a Roman, who ought not to be treated so. *Kettlewell*.

Smiles, not allowed to beasts, from reason move,  
 And are the *privilege* of human love. *Dryden*.

The great are *privileged* alone.  
 To punish all injustice but their own. *Id.*  
 The *privilege* of birth-right was a double portion. *Locke*.

He happier yet, who *privileged* by fate  
 To shorter labour, and a lighter weight,  
 Received but yesterday the gift of breath,  
 Ordained to-morrow to return to death. *Prior*.

As infallibility is no *privilege* of the human nature, it is no diminution to a man's good sense or judgment to be found in an error, provided he is willing to retract it. *Mason*.

**PRIVY, adj. & n. s.** } Fr. *privé*. Private; }  
**PRIVILY, adv.** } assigned to secret uses; }  
**PRIVITY, n. s.** } admitted to secrets; made }  
 conscious of: place of retirement, or for secret use: privily is, secretly; privately: privity, private communication; consciousness; joint knowledge; a secret part.

The sword of the great men that are slain entereth into their *privy* chamber. *Ezekiel* xxi. 14.

They have the profits of their lands by pretence of conveyances thereof unto their *privy* friends, who *privily* send them the revenues. *Spenser's State of Ireland*.

I will unto you in *privy* discover the drift of my purpose; I mean thereby to settle an eternal peace in that country, and also to make it very profitable to her majesty. *Spenser*.

The authority of higher powers hath force even in these things which are done without their *privy*, and are of mean reckoning. *Hooker*.

Upon this French going out, took he upon him, Without the *privy* o' the king, t' appoint Who should attend him. *Shakspeare. Henry VIII*.

The party, 'gainst the which he doth contrive,  
 Shall seize on half his goods; the other half  
 Comes to the *privy* coffer of the state. *Shakspeare*.

Sir Valentine  
 This night intends to steal away your daughter;  
 Myself am one made *privy* to the plot. *Id.*

*Few of them have any thing to cover their privities.*

*Abbot*

Many being *privy* to the fact,  
How hard is it to keep it unbetrayed?

*Daniel.*

One, having let his beard grow from the martyrdom of king Charles I. till the Restoration, desired to be made a *privy* counsellor.

*Spectator.*

All the doors were laid open for his departure, not without the *privy* of the prince of Orange, concluding that the kingdom might better be settled in his absence.

*Swift.*

He would rather lose half of his kingdom, than be *privy* to such a secret, which he commanded me never to mention.

*Id.*

Your fancy

Would still the same ideas give ye,  
As when you spied her on the *privy*.

*Id.*

**PRIVY COUNCIL.** See **COUNCIL.** The king's will is the sole constituent of a *privy* counsellor; and it also regulates their number, which in ancient times was about twelve. Afterwards it was increased to so large a number that it was found inconvenient for secrecy and despatch; and therefore Charles II. in 1679 limited it to thirty, whereof fifteen were principal officers of state, and to be counsellors *ex officio*; and the other fifteen were composed of ten lords, and five commoners of the king's choosing. Since that time, however, the number has been much augmented, and now continues indefinite. At the same time also the ancient office of lord president of the council was revived, in the person of Anthony earl of Shaftesbury. *Privy* counsellors are made by the king's nomination, without either patent or grant. Any natural born subject of Great Britain is capable of being a member of the *privy* council, taking the proper oaths for security of the government. By the act of settlement, 12 and 13 W. III. c. 2, it is enacted that no person born out of the dominions of the crown of England, unless born of English parents, even though naturalised by parliament, shall be capable of being of the *privy* council. The duty of a *privy* counsellor appears from the oath of office, which consists of seven articles. 1. To advise the king according to the best of his cunning and discretion. 2. To advise for the king's honor and good of the public, without partiality, through affection, love, meed, doubt, or dread. 3. To keep the king's council secret. 4. To avoid corruption. 5. To help and strengthen the execution of what shall be there resolved. 6. To withstand all persons who would attempt the contrary. And, lastly, in general, 7. To observe, keep, and do all that a good and true counsellor ought to do to his sovereign lord. The *privy* council is the primum mobile of the state, and that which gives the motion and direction to all the inferior parts. It is likewise a court of justice of great antiquity: the primitive and ordinary way of government in England being by the king and *privy* council. It has been frequently used by all our kings for determining controversies of great importance; the ordinary judges have sometimes declined giving judgment, till they had consulted the king and *privy* council; and the parliament have frequently referred matters of high moment to the same, as being, by long experience, better able to judge of, and by their

secrecy and expedition to transact some state affairs, than the lords and commons. At present the *privy* council takes cognizance of few or no matters except such as cannot be well determined by the known laws and ordinary courts; such as matters of complaint and sudden emergencies: their constant business being to consult for the public good in affairs of state. This power of the *privy* council is to enquire into all offences against the government, and to commit the offenders to safe custody, in order to take their trial in some of the courts of law. But their jurisdiction herein is only to enquire, and not to punish; and the persons committed by them are entitled to their habeas corpus by stat. 16 Car. I. c. 10, as much as if committed by an ordinary justice of the peace. In plantation or admiralty causes, which arise out of the jurisdiction of this kingdom, and in matters of lunacy and idiocy, the *privy* council has cognizance, even in questions of extensive property, being the court of appeal in such cases; or rather the appeal lies to the king's majesty himself in council. From all the dominions of the crown, excepting Great Britain and Ireland, an appellate jurisdiction (in the last resort) is vested in this tribunal; which usually exercises its judicial authority in a committee of the whole *privy* council, who hear the allegations and proofs, and make their report to his majesty in council, by whom the judgment is finally given. Anciently, to strike in the house of a *privy* counsellor, or elsewhere in his presence, was grievously punished: by 3 Hen. VII. c. 14, if any of the king's servants of his household conspire or imagine to take away the life of a *privy* counsellor, it is felony, though nothing shall be done upon it; and by 9 Ann. c. 16, it is enacted that any person who shall unlawfully attempt to kill, or shall unlawfully assault, and strike or wound any *privy* counsellor in the execution of his office, shall be felons, and suffer death as such. With advice of this council, the king issues proclamations that bind the subject, provided they be not contrary to law. In debates, the lowest delivers his opinion first, the king last, and thereby determines the matter. A council is never held without the presence of a minister of state. The dissolution of the *privy* council depends upon the king's pleasure; and he may, whenever he thinks proper, discharge any particular member, or the whole of it, and appoint another. By the common law also it was dissolved *ipso facto* by the king's demise, as deriving all its authority from him. But now, to prevent the inconveniences of having no council in being at the accession of a new prince, it is enacted by 6 Ann. c. 7, that the *privy* council shall continue for six months after the demise of the crown, unless sooner determined by the successor. Blackstone's Commentaries, book. i. p. 220, &c. The officers of the *privy* council are four clerks of the council in ordinary, three clerks extraordinary, a keeper of the records, and two keepers of the council chamber. See **PRESIDENT.**

**PRIVY COUNSELLOR,** a member of the *privy* council.

**PRIVY SEAL,** a seal which the king uses previously to such grants, &c. as are afterwards to pass the great seal. The *privy* seal is also some-

times used in matters of less consequence, which do not require the great seal.

PRIZE, *n. s. & v. a.* } Fr. *pris*; Teut. *preis*;  
PRIZER, } Lat. *pretium*. Reward;  
PRIZE-FIGHTER. } something gained in con-  
test or adventure; value; price: to rate; value;  
esteem: prizier is he who values: prize-fighter,  
he who publicly fights for hire or reward.

A goodly price that I was prized at of them.

*Zechariah xi. 13.*

The king of Scots she did send to France,  
To fill king Edward's fame with prisoner kings,  
And make his chronicle as rich with prize,  
As is the ozuy bottom of the sea  
With sunken wreck.

*Shakspeare. Henry V.*

Life I prize not a straw; but for mine honour  
Which I would free.

*Shakspeare.*

It holds its estimate and dignity,

As well wherein 'tis precious of itself,

As in the prizier.

*Id. Troilus and Cressida.*

Age, that all men overcomes, has made his prize  
on thee.

*Chapman.*

True poets empty fame and praise despise;

Fame is the trumpet, but your smile the prize.

*Dryden.*

I go to free us both of pain;

I prized your person, but your crown disdain.

*Id.*

The raising such silly competitions among the ignorant, proposing prizes for such useless accomplishments, and inspiring them with such absurd ideas of superiority, has in it something immoral as well as ridiculous.

*Addison.*

He acquitted himself like a valiant, but not like an honest man; for he converted the prizes to his own use.

*Arbuthnot.*

Martin and Crambe engaged like prizefighters.

*Id. and Pope.*

Then prostrate falls, and begs with ardent eyes

Soon to obtain and long possess the prize.

Some the French writers, some our own despise;

The ancients only, or the moderns prize.

*Id.*

They are not indeed suffered to dispute with us the proud prizes of arts and sciences, of learning and elegance, in which I have much suspicion they would often prove our superiors.

*Law.*

No strong the zeal to immortalize himself

Peats in the breast of man, that e'en a few,

Few transient years, won from the abyss abhorred

Of blank oblivion, seem a glorious prize,

And even to a clown.

*Cowper.*

PRIZE [prize, French, i. e. taken], in maritime affairs, a vessel taken at sea from the enemies of a state, or from pirates; and that either by a man of war, or privateer, &c, having a commission for that purpose. Vessels are looked on as prizes if they fight under any other standard than that of the state from which they have their commission; if they have no charter party, invoice, or bill of lading aboard; if laden with effects belonging to the king's enemies, or with contraband goods. In ships of war the prizes are to be divided among the officers, seamen, &c., as his majesty shall appoint by proclamation; but, among privateers, the division is according to the agreement between the owners. By stat. 13 Geo. II. c. 4, judges and officers failing of their duty in respect to the condemnation of prizes, forfeit £500 with full costs of suit; one moiety to the king, and the other to the informer.

PRO. Lat. *pro*. For; in defence of; pro and con, for *pro* and *contra*, for and against.

Doctrinal points in controversy had been agitated in the pulpits with more warmth than had used to be; and thence the animosity increased in books pro and con.

*Clarendon.*

Matthew met Richard, when

Of many knotty points they spoke.

And pro and con by turns they took. *Prior.*

PROA, flying, in navigation, a vessel used in the South Seas, so named because, with a brisk trade wind, it sails nearly twenty miles an hour. In the construction of the proa, the head and stern are exactly alike, but the sides are very different; the side intended to be always the lee-side being flat; and the windward side made rounding, in the manner of other vessels; and to prevent her oversetting, which from her small breadth, and the straight run of her leeward side, would without this precaution infallibly happen, there is a frame laid out to her from windward, to the end of which is fastened a log, fashioned into the shape of a small boat, and made hollow. The weight of the frame is intended to balance the proa, and the small boat is by its buoyancy (as it is always in the water) to prevent her oversetting to windward; and this frame is usually called an outrigger. The body of the vessel is made of two pieces joined endwise, and sewed together with bark, for there is no iron used about her; she is about two inches thick at the bottom, which at the gunwale is reduced to less than one. The sail is made of matting, and the mast, yard, boom, and outriggers, are all made of bamboo.

Their rigging consists of two stays that set up at the ends of the proa, and four shrouds that set up at the four corners of the frame. The sail is shaped like a settee-sail; and the lower end of the yard is confined forward in a shoe-block. In going about they keep her way, so that the stern becomes the head; and, to shift the sail, the yard is raised, and the lower end taken along the gunwale, and fixed in a shoe-block as before; the boom is shifted at the same, by slackening the sheet, and peaking the boom up along the mast; then, by hauling upon another sheet, the end of the boom is brought to the place where the lower yard-arm was before, and is hauled aft at the other end. They are steered by paddles at each end.

PROBABLE, *adj.* } Fr. *probable*; Lat. *pro-*  
PROBABILITY, *n. s.* } *babilis*. Likely; having  
PROBABLY, *adv.* } more evidence than the  
contrary: the noun substantive and adverb corresponding.

As for probabilities, what thing was there ever set down so agreeable with sound reason, but some probable shew against it might be made? *Hooker.*

The public approbation, given by the body of this whole church unto those things which are established, doth make it but probable that they are good, and therefore unto a necessary proof that they are not good it must give place. *Id.*

The only reasonable inquiry is, which is of probabilities the most, or of improbables the least such.

*Hammond.*

The reason why men are moved to believe a probability of gain by adventuring their stock into such foreign countries as they have never seen, and of which they have made no trial, is from the testimony of other credible persons.

*Wilkins.*

I do not say that the principles of religion are merely *probable*; I have before asserted them to be morally certain: and that to a man who is careful to preserve his mind free from prejudice, and to consider, they will appear unquestionable, and the deductions from them demonstrable. *Id.*

Though moral certainty be sometimes taken for a high degree of *probability*, which can only produce a doubtful assent; yet it is also frequently used for a firm assent to a thing upon such grounds as fully satisfy a prudent man. *Tillotson.*

If you like not my poem, the fault may possibly be in my writing; but more *probably* 'tis in your morals, which cannot bear the truth of it. *Dryden.*

Distinguish betwixt what may possibly, and what will *probably*, be done. *L'Estrange's Fables.*

*Probability* is the appearance of the agreement or disagreement of two ideas, by the intervention of proofs, whose connection is not constant; but appears for the most part to be so. *Locke.*

If a truth be certain, and thwart interest, it will quickly fetch it down to but a *probability*; nay, if it does not carry with it an impregnable evidence, it will go near to debase it to a downright falsity. *South.*

They assented to things that were neither evident nor certain, but only *probable*; for they conversed, they merchandized, upon a *probable* persuasion of the honesty and truth of those whom they corresponded with. *Id.*

Our constitution in church or state could not *probably* have been long preserved without such methods. *Suiff.*

Which tempers, if they were duly improved by proper studies, and sober methods of education, would in all *probability* carry them to greater heights of piety than are to be found amongst the generality of men. *Law.*

**PROBAT**, or **PROBATE**, of a will or testament, in law, is the exhibiting and proving of last wills and testaments before the ecclesiastical judge delegated by the bishop, who is ordinary of the piece where the party died.

**PROBATION**, *n. s.* } *Fr. probation*; *Lat. probatio*, from *Lat. probatio*, from *Lat. probare*. Proof; testimony; act or time of proving; or of trial: probatory and probatory mean serving for trial: probationer, one who is on his trial; hence, a novice: probationership, his state or time of trial; noviceate.

Of the truth herein,

This present object made *probation*.

*Shakspeare's Hamlet.*

In the practical part of knowledge, much will be left to experience and *probation*, whereunto indication cannot so fully reach. *Bacon's Natural History.*

This root of bitterness was but a *probationer* in the soil; and, though it set forth some offsets to preserve its kind, yet Satan was fain to cherish them.

*Decay of Piety.*

Job's afflictions were no vindictory punishments, but *probatory* chastisements to make trial of his graces. *Bramhall.*

The kinds of *probation* for several things being as much disproportioned as the objects of the several senses are to one another. *Wilkins.*

Hear a mortal muse thy praise rehearse,

In no ignoble verse;

But such as thy own verse did practise here,

When thy first fruits of poetry were given,

To make thyself a welcome inmate there;

While yet a young *probationer*,

And candidate of heaven.

*Dryden.*

When these principles, what is, is, and it is impossible for the same thing to be and not to be, are made use of in the *probation* of propositions, wherein are words standing for complex ideas, as man or horse, there they make men receive and retain falsehood for manifest truth. *Locke.*

He has afforded us only the twilight of *probability*, suitable to that state of mediocrity and *probationership* he has been pleased to place us in here, wherein to check our over-confidence. *Id.*

At the end of the world, when the state of our trial and *probation* shall be finished, it will be a proper season for the distribution of publick justice. *Nelson.*

I suffer many things as an author militant, whereof, in your days of *probation*, you have been a sharer. *Pope to Suiff.*

Build a thousand churches, where these *probationers* may read their wall lectures. *Swift.*

**PROBATION**, in the universities, is the examination and trial of a student who is about to take his degrees.

**PROBATION**, in the monastic sense, signifies the year of a noviceate, which a religious must pass in a convent to prove his virtue and vocation, and whether he can bear the severities of the rule.

**PROBATIONER**, in the church of Scotland, a student in divinity, who, bringing a certificate from a professor in a university of his good morals, and his having performed his exercises to approbation, is admitted to undergo several trials; and, upon his acquitting himself properly in these, receives a license to preach.

**PROBATUM EST**. *Lat. probatum est*. A phrase added to the end of a receipt, signifying it is tried or proved.

Vain the concern that you express,

That uncalled Alard will possess

Your house and coach both day and night,

And that Macbeth was haunted less

By Banquo's restless sprite :

Lead him but fifty louis d'or,

And you shall never see him more ;

Take my advice, *probatum est*.

Why do the gods indulge our store,

But to secure our rest ?

*Prior.*

**PROBE**, *n. s.* } *Lat. proba*. A slender

**PROBE-SCISSORS**. } wire by which surgeons search the depth of wounds: probe-scissors, are scissors attached to a probe.

A round white stone was lodged, which was so fastened in that part, that the physician with his *probe* could not stir it. *Fell.*

He'd raise a blush where secret vice he found ;

And tickle while he gently *probed* the wound.

*Druden.*

Nothing can be more painful, than to *probe* and search a purulent old sore to the bottom. *South.*

I made search with a *probe*.

*Wiseman's Surgery.*

The sinus was snipt up with *probe-scissors*.

*Wiseman.*

**PROBITY**, *n. s.* } *Fr. probité*; *Lat. probitas*  
Honesty; sincerity; veracity.

The truth of our Lord's ascension might be deduced from the *probity* of the apostles. *Fiddes.*

So near approach we their celestial kind,

By justice, truth, and *probity* of mind. *Pope.*

**PROBLEM**, *n. s.* }

French *probleme* ;

**PROBLEMATIC**, *adj.* } *Gr. προβλημα*. A

**PROBLEMATICALLY**, *adv.* } question proposed.

problematical is, uncertain; questionable, the adverb corresponding.

The *problem* is, whether a man constantly and strongly believing that such a thing shall be, it doth help any thing to the effecting of the thing.

*Bacon.*

It is a question *problematical* and dubious, whether the observation of the sabbath was imposed upon Adam, and his posterity in paradise? *White.*

Deeming that abundantly confirmed to advance it above a disputable *problem*, I proceed to the next proposition. *Hammond.*

Although in general one understood colours, yet were it not an easy *problem* to resolve, why grass is green? *Browne.*

I promised no better arguments than might be expected in a point *problematical*. *Boyle.*

This *problem* let philosophers resolve, What makes the globe from West to East revolve? *Blackmore.*

Diligent enquiries into remote and *problematical* guilt, leave a gate wide open to the whole tribe of jailormers. *Swift.*

**PROBLEM**, in geometry, is a proposition, wherein some operation or construction is required; as to divide a line or angle, erect or let fall perpendiculars, &c. See **GEOMETRY**.

**PROBLEM**, in logic, is a proposition that neither appears absolutely true nor false; and consequently may be asserted either in the affirmative or negative.

**PROBOSCIS**, *n. s.* Latin *proboscis*. A snout; particularly the trunk of an elephant.

The elephant wreathed, to make them sport, His lithe *proboscis*. *Milton.*

**PROBUS** (Marcus Aurelius), from the son of a gardener, became, by his great valor as a soldier, and his eminent virtues, emperor of Rome, to which dignity he was raised by the army, After having subdued the barbarous nations that had made incursions into different parts of the empire, and governed with great wisdom and clemency, he was massacred in the seventh year of his reign, by some soldiers weary of the public works at which he made them labor, in 282. See **ROME**.

**PROCAS**, a king of Alba, one of the descendants of Aeneas, the son and successor of Aventinus, father of Amulius and Numitor, and great-grandfather to Romulus.

**PROCATARCTICK**, *adj.* Gr. προκαταρκτης. Forerunning; remotely antecedent.

**PROCATARXIS**, *n. s.* An antecedent or pre-existent cause.

The physician enquires into the *procatarctick* causes. *Harvey.*

*Procatarxis* is the pre-existent cause of a disease, which co-operates with others that are subsequent, whether internal or external; as anger or heat of climate, which brings such an ill disposition of the juices, as occasions a fever: the ill disposition being the immediate cause, and the bad air the *procatarctick* cause. *Quincy.*

**PROCEED**, *v. n. & n. s.* } Fr. *proceder*;  
**PROCEEDER**, *n. s.* } Lat. *proceda*. To  
**PROCEEDING**, } pass from one  
**PROCE'DURE**. } thing or place to

another; advance; go forth in form or state; issue; be propagated; transact; carry on an affair methodically; prosecute a legal suit; take effect; have its course: a *proceeder* is, he who

proceeds in any way; proceeding, and procedure, process; issue; transaction; manner of proceeding; course of conduct: legal method of process.

I *proceeded* forth and came from God; neither came I of myself, but he sent me. *John viii. 42.*

Temperately *proceed* to what you would Thus violently redress. *Shakspeare. Coriolanus*  
A dagger of the mind, a false creation  
*Proceeding* from the heat oppressed brain. *Shakspeare.*

He will after his sour fashion, tell you What hath *proceeded* worthy note to-day. *Id.*

I'll acquaint our duteous citizens With all your just *proceedings* in this case. *Id.*  
No known substance, but earth and the *procedures* of earth, as tile and stone, yield: h any moss or herby substance. *Bacon.*

He that seeketh victory over his nature, let him not set himself too great nor too small tasks; for the first will make him dejected by often failing; and the second will make him a small *proceeder*, though by often prevailings. *Id.*

These things, when they *proceed* not, they go backward. *Ben Jonson's Catiline.*

Adam  
*Proceeded* thus to ask his heavenly guest. *Milton.*

To judgment he *proceeded* on the accused. *Id.*

O Adam, one Almighty is, from whom All things *proceed*, and up to him return. *Id.*

Although the distinction of these several *procedures* of the soul do not always appear distinct, especially in sudden actions, yet in actions of weight all these have their distinct order and *procedure*. *Hale's Origin of Mankind.*

Instead of a ship to levy upon his county such a sum of money for his majesty's use, with direction in what manner he should *proceed* against such as refused. *Clarendon.*

Then to the prelude of a war *proceeds*; His horns, yet sore, he tries against a tree. *Dryden.*

All this *proceeded* not from any want of knowledge. *Id.*

I shall *proceed* to more complex ideas. *Locke.*

The understanding brought to knowledge by degrees, and in such a general *proceeding*, nothing is hard. *Id.*

Clear the justice of God's *proceedings*, it seems reasonable there should be a future judgment for a suitable distribution of rewards and punishments. *Nelson.*

This is the true *procedure* of conscience, always supposing a law from God, before it lays obligation upon man. *South.*

Since husbandry is of large extent, the poet singles out such precepts to *proceed* on as are capable of ornament. *Addison.*

This rule only *proceeds* and takes place, when a person cannot of common law condemn another by his sentence. *Auliffe.*

It is a very unusual *proceeding*, and I would not have been guilty of it for the world. *Arbuthnot.*

How severely with themselves *proceed*, The men who write such verse as who can read? Their own strict judges, not a word they spare, That wants or force, or light, or weight, or care. *Pope.*

From the earliest ages of christianity there never was a precedent of such a *proceeding*. *Swift.*

Parts of the judicial *procedures*, which were at first only accidental, become in time essential. *Johnson.*



A cheek and lip—but why proceed?

I loved her then—I love her still;

And such as I am love indeed

In fierce extremes—in good and ill. *Byron.*

**PROCELEUSMATICUS**, in the ancient poetry, a foot consisting of four short syllables, or two pyrrhics, as *hōminibūs*.

**PROCELLARIA**, in ornithology, a genus of birds, belonging to the order of anseres. The beak is somewhat compressed, and without teeth; the mandibles are equal, the superior one being crooked at the point; the feet are palmated, the hind claw being sessile, without any toe. Latham enumerates twenty-four species, chiefly distinguished by their colors. The most remarkable are the following:—

1. *P. æquinoctialis*. It is nearly of the size of a raven; its color is a deep sooty brown or blackish; on the chin there is a small patch of white running down a little on each side from the lower mandible: the beak is of yellowish white.

2. *P. cinerea*, the petrel. The size of this bird is rather superior to that of the common gull: the bill very strong, much hooked at the end, and of a yellow color. The nostrils are composed of two large tubes, lodged in one sheath; the head, neck, whole under side of the body and tail are white; the back and coverts of the wings ash-colored; the quill-feathers dusky; and the legs yellowish. In lieu of a back toe, it has only a sort of spur, or sharp straight nail. These birds feed on the fat of whales, &c., and are likewise said to eat sorrel, to qualify the unctuous diet they live on. This species inhabit the isle of St. Kilda; appear there in November, and continue the whole year, except September and October; lay a large, white, and very brittle egg; and the young are hatched in the middle of June. No bird is of such use to the islanders as this; it supplies them with oil for their lamps, down for their beds, a delicacy for their tables, a balm for their wounds, and a medicine for their distempers. It is also a certain prognosticator of the change of the wind: if it comes to land, no west wind is expected for some time; and the contrary when it returns and keeps the sea. The whole genus of petrels have a peculiar faculty of spouting from their bills, to a considerable distance, a large quantity of pure oil; which they do by way of defence, into the face of any one that attempts to take them; so that they are, for the sake of this panacœa, seized by surprise, as this oil has been applied to medical purposes. Frederick Martens, who had an opportunity of seeing vast numbers of these birds at Spitzbergen, says they are very bold, and resort after the whale fishers in great flocks; and that, when a whale is taken, they light on it, and pick out large lumps of fat, even while the animal is alive; that the whales are often discovered at sea by the multitudes of them flying; and that, when one is wounded, they immediately follow its bloody track.

3. *P. pelagica*, the stormy petrel, is about the bulk of the house swallow: the length six inches, the extent of wings thirteen. The whole bird is black, except the coverts of the tail and vent-feathers, which are white; the bill is hooked at the

end; the nostrils tubular; the legs slender and long. It has the same faculty of spouting oil from its bill as the other species. Excepting in breeding time, they are always at sea; and are seen all over the vast Atlantic Ocean, at the greatest distance from land; often following the vessels in great flocks, to pick up any thing that falls from on board. They presage bad weather, and caution the seamen of the approach of a tempest, by collecting under the stern of the ships; they brave the utmost fury of the storm, sometimes skimming with incredible velocity along the hollows of the waves, sometimes on the summits. These birds are the cypseli of Pliny, which he places among the apods of Aristotle; not because they wanted feet, but were *κακοποδα*, or had bad or useless ones; an attribute he gives to these species, on the supposition that they are almost always on the wing. In August, 1772, Pennant found them on the rocks called Macdonald's Table, off the north end of the isle of Skye; and conjectures they breed there. They lurked under the loose stones, but their twittering noise betrayed them.

4. *P. puffinus*, the shear-water, is fifteen inches long, and thirty-one broad; the weight seventeen ounces; the bill is an inch and three-quarters long; nostrils tubular, but not very prominent; the head, and whole upper side of the body, wings, tail, and thighs, are of a sooty blackness; the under side from chin to tail, and inner coverts of the wings, white; the legs weak, and compressed sidewise; dusky behind, whitish before. These birds are found in the Calf of Man; and, as Mr. Ray supposes, in the Scilly Isles. They resort to the former in February; take possession of the rabbit burrows, and disappear till April. They lay one egg, white and blunt at each end; and the young are fit to be taken in the beginning of August; when great numbers are killed by the person who farms the isle; they are salted and barrelled; and, when they are boiled, are eaten with potatoes. During the day, they keep at sea fishing; and toward evening return to their young; whom they feed, by discharging the contents of their stomachs into their mouths, which by that time is turned into oil. They quit the isle about the end of August; and are dispersed over the Atlantic. This species inhabits also the Orkney Isles, where it makes its nest in holes on the earth near the shelves of the rocks and headlands; it is called there the lyre; and is much valued both as food, and for its feathers. The inhabitants salt them in August for winter provisions. They also take the old ones in March; but they are then poor, and not so well tasted as the young: they first appear in those islands in February.

**PROCEPTION**, *n. s.* Lat. *pro* and *capio*. Preoccupation; act of taking something sooner than another. A word not in use.

Having so little power to offend others that I have none to preserve what is mine own from their *proception*.  
*King Charles.*

**PROCERITY**, *n. s.* Lat. *procerus*. Tallness; height of stature.

We shall make attempts to lengthen out the human figure, and restore it to its ancient *procerity*.

*Addison*

When he met a tall woman he immediately commanded one of his Titanian retinue to marry her, that he might propagate *procerity*, and produce heirs to the father's habiliments. *Johnson.*

Mr. Higgins says he has observed that *procerity* is much promoted by the equal length of the legs, more especially when they are long legs. *Canning.*

**PROCESS**, *n. s.* *Fr. proces; Lat. processus.* Tendency; progressive course; progress; flux; methodical arrangement or management; legal course or proceeding.

That there is somewhat higher than either of these two, no other proof doth need, than the very *process* of man's desire, which being natural should be frustrate, if there were not some farther thing wherein it might rest at the length contented, which in the former it cannot do. *Hooker.*

They declared unto him the whole *process* of that war, and with what success they had endured. *Knolles.*

Commend me to your honourable wife;  
Tell her the *process* of Antonio's end;  
Say how I lov'd you; speak me fair in death. *Shakespeare.*

Proceed by *process*,

Lest parties, as he is beloved, break out. *Id.*  
All *processes* ecclesiastical should be made in the king's name, as in writs at the common law. *Hayward.*

Immediate are the acts of God, more swift  
Than time or motion; but to human ears  
Cannot without *process* of speech be told. *Milton.*

Many acts of parliament have, in long *process* of time, been lost, and the things forgotten. *Hale.*  
Experiments, familiar to chymists, are unknown to the learned who never read chymical *processes*. *Boyle.*

That a suit of law, and all judicial *process*, is not in itself a sin, appears from courts being erected by consent in the apostle's days, for the management and conduct of them. *Kettlewell.*

Saturnian Juno

Attends the fatal *process* of the war. *Dryden.*  
The *process* of that great day, with several of the particular circumstances of it, are fully described by our Saviour. *Nelson.*

An age they live released  
From all the labour, *process*, clamour, woe,  
Which our sad scenes of daily action know. *Prior.*

In the parable of the wasteful steward, we have a lively image of the force and *process* of this temptation. *Rogers.*

The patricians they chose for their patrons, to answer for their appearance, and defend them in any *process*. *Swift.*

**PROCESSION**, *n. s.* } French *procession*;  
**PROCESSIONAL**, *adj.* } Lat. *processio*. **PRO-**  
**PROCESSIONARY**. } gress; a train marching in ceremonious solemnity: the adjective corresponds on long.

If there be cause for the church to go forth in solemn *procession*, his whole family have such business come upon them that no one can be spared. *Hooker.*

Rogations or litanies were then the very strength and comfort of God's church, whereupon, in the year 506, it was by the council of Aurelia decreed, that the whole church should bestow yearly, at the feast of Pentecost, three days in that *processionary* service. *Id.*

Him all his train  
Followed in bright *procession*. *Milton.*

VOL. XVIII.

The priests, Pontitius at their head,  
In skins of beasts involved, the long *procession* led. *Dryden.*

When this vast congregation was formed into a regular *procession*, to attend the ark of the covenant, the king marched at the head of his people, with hymns and dances. *Addison.*

The Ethiopians held an annual sacrifice of twelve days to the gods; all that time they carried their images in *procession*, and placed them at their festivals. *Broome.*

**PROCESS IN LAW**. See **LAW**.

**PROCHEIN AMY**, in law, the person next akin to a child in non-age, and who, in that respect, is allowed to act for him, and be his guardian, &c., if he hold land in soccage. To sue, an infant is not allowed to make an attorney; but the court will admit his next friend as plaintiff, or his guardian as defendant.

**PROCIDA**, an island, with a sea-port of the same name, on the coast of Naples, between the island of Ischia and the promontory of Misenum. Though containing only seven square miles, the population of this island exceeds 12,000, of whom a large proportion lives in the chief town, carrying on a brisk trade. Others derive their support from fishing, and a few from rearing vines and silk. Game is uncommonly abundant here. This island was taken by the English in 1809, but soon after evacuated. It is twenty-two miles west of Naples.

**PROCINCT**, *n. s.* Lat. *procinctus*. Complete preparation; preparation to the point of action.

When all the plain  
Covered with thick imbattled squadrons bright,  
Chariots, and flaming arms, and fiery steeds,  
Reflecting blaze on blaze, first met his view,  
War he perceived, war in *procinct*. *Milton.*

**PROCKIA**, in botany, a genus of the monogynia order, and polyandria class of plants; natural order doubtful: *cat. triphyllous*, besides two leaflets at the base: *cor. berry quinqueangular, and polyspermous*.

**PROCLAIM**, *v. a.* } *Fr. proclamer; Lat*  
**PROCLAIMER**, *n. s.* } *proclamo*. To promul-  
**PROCLAMATION**. } gate or denounce solemnly: openly tell; outlaw: proclamation is publication by authority; declaration of the king's will openly published.

When thou comest nigh unto a city to fight against it, *proclaim* peace unto it. *Deut. xx. 10.*

I *proclaim* a liberty for you, saith the Lord, to the sword and to the pestilence. *Jer. xxxiv. 17.*

I heard myself *proclaimed*. *Shakespeare.*  
If the king sent a *proclamation* for their repair to their houses, some nobleman published a protestation against those *proclamations*. *Clarendon.*

Heralds,  
With trumpet's sound, throughout the host *proclaim*  
A solemn council. *Milton.*

The great *proclaimer*, with a voice  
More awful than the sound of trumpet, cried  
Repentance, and heaven's kingdom nigh at hand  
To all baptised. *Id. Paradise Regained.*

She to the palace led her guest,  
Then offered incense, and *proclaimed* a feast. *Dryden.*

Some profligate wretches, were the apprehensions of punishments of shame taken away, would as openly *proclaim* their atheism as their lives do. *Locke.*

K

While the deathless muse  
Shall sing the just, shall o'er their head diffuse  
Perfumes with lavish hand, she shall proclaim  
Thy crimes alone.

Then view him self-proclaimed in a gazette  
Chief monster that has plagued the nations yet:  
The globe and sceptre in such hands misplaced,  
Those ensigns of dominion how disgraced!

*Couper.*

PROCLAMATIONS are a branch of the king's prerogative (see PREROGATIVE); and have then a binding force, 'when,' as Sir Edward Coke observes, 'they are grounded upon and enforce the laws of the realm. For, though the making of laws is entirely the work of a distinct part, the legislative branch of the sovereign power, yet the manner, time, and circumstances of putting those laws into execution, must frequently be left to the discretion of the executive magistrate. And therefore his constitutions or edicts, concerning those points which we call proclamations, are binding upon the subject, where they do not either contradict the old laws, or tend to establish new ones, but only enforce the execution of such laws as are already in being, in such manner as the king shall judge necessary.'

PROCLÉS, a king of Sparta, the son of Aristodemus and Argia, and the twin brother of Eurysthenes, who reigned jointly with him, and gave rise to the two royal families of Proclidæ and Eurysthenidæ, who governed Sparta for several centuries, exhibiting the singular political phenomena of a binarchy, or two hereditary kings governing with equal, but limited power.

PROCLÉS, the son of Eucrates, a Carthaginian historian, who wrote some historical treatises, which are lost, except a few fragments preserved in the works of Pausanias.—Paus. iv. c. 35.

PROCLIVITY, *n. s.* Lat. *proclivitas*, *proclivis*. Tendency: natural inclination; propension.

He had such a dextrous *proclivity* as his teachers were fain to restrain his forwardness, that his brothers might keep pace with him.

*Hotton.*

The sensitive appetite may engender a *proclivity* to steal, but not a necessity to steal.

*Bramhall.*

PROCLUS, surnamed Diadocus, a Greek philosopher and mathematician, was born at Ly-sia, and lived about the year 500. He was the disciple of Syrianus. It is said that, when Vit-alian laid siege to Constantinople, Proclus burnt his ships with large brazen specula. This philo-sopher was a Pagan, and wrote against the Christian religion. There are still extant his Commentaries on some of Plato's books, and others of his works written in Greek.

PROCONSUL, *n. s.* Latin *proconsul*. A Roman officer who governed a province with consular authority.

Every child knoweth how dear the works of Homer were to Alexander, Virgil to Augustus, Ausonius to Gratian, who made him *proconsul*, Chaucer to Richard II., and Gower to Henry IV.

*Peacham.*

PROCONSULS were appointed out of the body of the senate; and usually as the year of any one's consulate expired, he was sent proconsul into some province. The proconsuls decided cases of equity and justice, either privately in their prætorium or palace, where they received petitions, heard complaints, granted writs under

their seal, and the like; or else publicly in the common hall, with the usual formalities observed in the court of judicature at Rome. They had besides, by virtue of their edicts, the power of ordering all things relating to the tribunes, taxes, contributions, and provisions of corn and money, &c. Their office lasted only a year. See CON-SUL.

PROCOPIUS, a celebrated Greek historian, born in Cæsarea, who acquired great reputation by his works in the reign of Justinian, and was secretary to Belisarius during all the wars carried on by that general, in Persia, Africa, and Italy. He at length became senator, obtained the title of illustrious, and was made prætor of Constan-tinople.

PROCRASTINATE, *v. a. & v. n.* } Latin  
PROCRASTINATION, *n. s.* } *procrasti-*  
nor. To defer; delay; be dilatory: the noun substantive corresponds.

Hopeless and helpless doth Ægeon wind,  
But to procrastinate his lifeless end. *Shakespeare.*  
Let men seriously and attentively listen to that voice within them, and they will certainly need no other medium to convince them, either of the error or danger of thus procrastinating their repentance.

*Decay of Piety.*

How desperate the hazard of such procrastination is, hath been convincingly demonstrated by better pens.

*Id.*

Set out early and resolutely without procrastinating or looking back.

*Hammond.*

I procrastinate more than I did twenty years ago, and have several things to finish, which I put off to twenty years hence.

*Swift to Pope.*

Procrastination is the thief of time,  
Year after year it steals, till all are fled,  
And to the mercies of a moment leaves  
The vast concerns of an eternal scene.

*Young.*

PROCREATE, *v. a.* } Fr. *procreer*; Lat.  
PROCREANT, *adj.* } *procreo, procreans.* To  
PROCREATION, *n. s.* } generate; produce:  
PROCREATIVE, *adj.* } procreant and procrea-  
PROCREATIVENESS. } tive mean producing;  
pregnant: procreation and procreativeness cor-responding.

The temple-haunting martlet does approve,  
By his loved mansionry, that heaven's breath  
Smells wooingly here: no jutting frieze,  
But this bird  
Hath made his pendant bed, and procreant cradle.

*Shakespeare.*

The inclosed warmth, which the earth hath sucked up by the heat of the sun, assisteth nature in the speedier procreation of those varieties which the earth bringeth forth.

*Raleigh.*

These have the accurst privilege of propagating and not expiring, and have reconciled the procreativity of corporeal, with the duration of incorporeal substances.

*Decay of Piety.*

Neither her outside formed so fair, nor aught  
In procreation common to all kinds.  
The ordinary period of the human procreative fa-  
culty in males is sixty-five, in females forty-five.

*Hale.*

Uncleanness is an unlawful gratification of the ap-  
petite of procreation.

*Souch.*

Since the earth retains her fruitful power,  
To procreate plants the forest to restore,  
Say, why to nobler animals alone  
Should she be feeble, and unfruitful grown?

*Blackmore.*

Flies crushed and corrupted, when inclosed in such vessels, did never *procreate* a new fly.

*Bentley.*

**PROCRIIS**, a daughter of Pandion, or, according to others, of Erechtheus, king of Athens, and wife of Cephalus. See **CEPHALUS**.

**PROCRUSTES**, in fabulous history, a famous robber of Attica, who was killed by Theseus, near the Cephissus. He used to tie travellers upon a bed; and, if their length exceeded that of his bed, he cut off their feet and as much of their legs as exceeded; but if they were shorter, he racked and stretched them till their length was equal to his own—an emphatic emblem of bigotry. He is called by some **Damnastes**.

**PROCTOR**, *n. s.* Contracted of Lat. *procurator*. A manager of another man's affairs; an ecclesiastical and university officer.

The most clamorous for this pretended reformation are either atheists, or else *proctors* suborned by atheists.

*Hooker.*

I cannot *proctor* mine own cause so well  
To make it clear.

*Shakspeare. Antony and Cleopatra.*

From a scholar he became a fellow, and the president of the college, after he had received all the graces and degrees, the *proctorship* and the doctorship.

*Clarendon.*

The *proctor* sent his servitor to call him.

*Walter.*

I find him charging the inconveniences in the payment of *tythes* upon the clergy and *proctors*.

*Swift.*

**PROCULEIUS**, a Roman knight, who was very intimate with Augustus. He is justly famed for his fraternal affection to his brothers, **Muræna** and **Scipio**, with whom he divided his possessions, after they had forfeited their estates, and offended Augustus, by joining with Pompey the younger. He was sent by Augustus to queen **Cleopatra**, to persuade her to surrender to him, but failed.

PROCURE', <i>v. a. &amp; v. n.</i>	} Fr. <i>procurer</i> ; Lat. <i>procuror</i> . To manage; transact for another; obtain; forward; contrive; persuade; prevail on; to pimp; procurable; is obtainable; to be acquired: procuracy and procuracy, management or transaction of a thing, particularly for another: procurator, he who so manages or transacts affairs: procuratorial, made by, or pertaining to a proctor: procurement is the act of procuring: procurer, one who gains; obtains, or acquires, particularly for others; a pander: <i>procurer</i> , a bawd.
PROCURABLE, <i>adj.</i>	
PROCURACY, <i>n. s.</i>	
PROCURATION,	
PROCURATOR,	
PROCURATORIAL, <i>adj.</i>	
PROCUREMENT, <i>n. s.</i>	
PROCURER,	
PROCURERESS.	

They shall fear and tremble, for all the prosperity that I *procure* unto it.

*Jeremiah xxxiii. 9.*

I had in charge at my depart from France,

As *procurator* for your excellence,

To marry princess Marg'ret for your grace.

*Shakspeare.*

Is it my lady mother?

What unaccustomed cause *procures* her hither? *Id.*

Proceed, **Salinus**, to *procure* my fall,

And by the doom of death end woes and all *Id.*

Whom nothing can *procure*,  
When the wide world runs bias, from his will  
To writhe his limbs, and share, not mend the ill.

*Herbert.*

They confirm and seal  
Their undertaking with their dearest blood,  
As *procurators* for the commonweal.

*Daniel.*

Happy, though but ill,

If we *procure* not to ourselves more woe.

*Milton.*

Angling was, after tedious study, a moderator of passions, and a *procurer* of contentedness.

*Walton.*

Though it be a far more common and *procurable* liquor than the infusion of *lignum nephriticum*, it may yet be easily substituted in its room.

*Boyle.*

We no other pains endure,

Than those that we ourselves *procure*.

*Dryden.*

**PROCURATOR**, among the Romans; an agent, an overseer of an estate; at a later period, the title of a provincial officer, inferior to the governor (see **Province**, and **Proconsul**), who managed the revenue. In some of the small provinces, or in a part of a large province, the procurator discharged the office of a governor, and had the power of punishing capitally, as was the case with **Pontius Pilate**, in **Judæa**, which was attached to the province of **Syria**. In the civil law, the procurator, or proctor, answers to the attorney in the common law. (See **advocate of the crown**.)—Procurator, or proctor, in monasteries, is the conventual, to whom is intrusted the care of the temporal concerns.—Procurator di San Marco was the title of the chief officers or senators in the Venetian republic. Beside the nine actual procuratori, from among whom the Doge was chosen, there were also many titular procurators, who paid a great sum for this title, which was much coveted by the Venetian patricians on account of the rank it conferred.

**PROCYON**, in ancient astronomy, a star near the dog-star, before which it generally rises in July. Cicero calls it **Anticanis**, which signifies the same with *πρόκυων*.

**PRODANO** (the ancient **Prote**), a small island of Greece, on the west coast of the **Morea**, and separated from it only by a narrow channel. It forms a small but secure bay, sixteen miles north by west of **Navarin**. Lat. 37° 10' N.

**PRODICUS**, a celebrated sophist and rhetorician of **Cos**, who flourished about **A. A. C. 396**. He was sent ambassador by the **Coans** to **Athens**, where he taught publicly, and had among his pupils **Socrates**, **Euripides**, **Theramenes**, and **Isocrates**. He travelled through most towns of Greece, and made his auditors pay to hear his lectures. His writings were numerous; and among them was the well known beautiful episode of **Hercules's Choice**, when addressed by **Pleasure** and **Virtue**, when the hero became the votary of the latter goddess. **Prodicus** experienced the fate of his excellent pupil, **Socrates**, being at last put to death by the Athenians, on pretence that he corrupted the morals of their youth. **Xenoph. Mem.**

**PRODIGAL**, *adj.* } Fr. *prodigue*; Lat.

**PRODIGALITY**, *n. s.* } *prodigius*. Profuse;

**PRODIGALLY**, *adv.* } wasteful; expensive; lavish; with *of* before the object, and the noun substantive and adverb corresponding.

Be now as *prodigal* of all dear grace,  
 As nature was in making graces dear,  
 When she did starve the general world beside,  
 And *prodigally* gave them all to you. *Shakspeare.*  
 A sweeter and lovelier gentleman,  
 Framed in the *prodigality* of nature,  
 The spacious world cannot again afford. *Id.*  
 Diogenes did beg more of a *prodigal* man than the  
 rest; whereupon one said, see your baseness, that  
 when you find a liberal mind, you will take most of  
 him; no, said Diogenes, but I mean to beg of the  
 rest again. *Bacon.*

Let I should seem over *prodigal* in the praise of  
 my countrymen, I will only present you with some  
 few verses. *Camden.*

We are not yet so wretched in our fortunes,  
 Nor in our wills so lost, as to abandon  
 A friendship *prodigally*, of that price  
 As is the senate and the people of Rome.  
*Ben Jonson.*

A beggar grows rich, becomes a *prodigal*; for to  
 obscure his former obscurity, he puts on riot and ex-  
 cess. *Id.*

Lucian has well described the fate of *prodigals* in  
 his picture of Opulentia, whose residence he repre-  
 sents to be on a lofty mountain, the summit of which  
 her fond votaries are eagerly endeavouring to reach.  
*Burton.*

I cannot well be thought so *prodigally* thirsty of  
 my subject's blood as to venture my own life.  
*King Charles.*

As a hero, whom his baser foes  
 In troops surround; now these assail, now those,  
 Though *prodigal* of life, disdains to die  
 By common hands. *Denham.*

He that decries covetousness, should not be held  
 an adversary to him that opposeth *prodigality*.  
*Glanville.*

The *prodigal* of soul rushed on the stroke  
 Of lifted weapons, and did wounds provoke.  
*Dryden.*

Let the wasteful *prodigal* be slain.  
 The most severe censor cannot but be pleased  
 with the *prodigality* of his wit, though at the same  
 time he could have wished, that the master of it had  
 been a better manager. *Id.*

Nature not bounteous now, but lavish grows,  
 Our paths with flowers she *prodigally* strows.  
*Id.*

O! beware,  
 Great warrior, nor, too *prodigal* of life,  
 Expose the British safety. *Philips.*  
 It is not always so obvious to distinguish be-  
 tween an act of liberality and act of *prodigality*.  
*South.*

PRODIGIOUS, *adj.* } Fr. *prodigieux*;  
 PRODIGIOUSLY, *adv.* } Lat. *prodigiosus*.  
 PRODIGIOUSNESS, *n. s.* } Amazing; astonish-  
 PRODIGY. } ing; portentous;  
 enormous; monstrous: the adverb and noun  
 substantive corresponding: prodigy is, any thing  
 out of the ordinary process of nature; portent.

Be no more an exhaled meteor,  
 A *prodigy* of fear, and a portent  
 Of broached mischief to the unborn times.  
*Shakspeare.*

If e'er he have a child, abortive be it,  
*Prodigious* and untimely brought to light! *Id.*  
 An emission of immateriate virtues we are a  
 little doubtful for propound, it being so *prodigious*;  
 but that it is constantly avouched by many. *Bacon.*  
 Most of mankind, through their own sluggish-  
 ness, become nature's *prodigies*, not her children.  
*Ben Jonson.*

It is *prodigious* to have thunder in a clear sky.  
*Browne.*

Then ent'ring at the gate,  
 Concealed in clouds, *prodigious* to relate,  
 He mixed, unmarked, amongst the busy throng.  
*Dryden.*

I do not mean absolutely according to philoso-  
 phic exactness infinite, but only infinite or innume-  
 rable as to us, or their number *prodigiously* great.  
*Ray on the Creation.*

They would seem *prodigies* of learning.  
*Spectator.*

The party opposite to our settlement seem to be  
 driven out of all human methods, and are reduced  
 to the poor comfort of *prodigies* and old woman's  
 fables. *Addison.*

The Rhone enters the lake, and brings along with  
 it a *prodigious* quantity of water. *Id.*

I am *prodigiously* pleased with this joint volume.  
*Pope.*

It is a scandal to Christianity that in towns, where  
 there is a *prodigious* increase in the number of houses  
 and inhabitants, so little care should be taken for  
 churches. *Swift.*

PRODITOR, *n. s.* Lat. *proditor*. A traitor.  
 Not in use.

Pieled priest, dost thou command me be shut out?  
 —I do, thou most usurping *proditor*. *Shakspeare.*  
 Solid and conclusive characters are emergent from  
 the mind, and start out of children when themselves  
 least think of it; for nature is *proditorious*.

Now *proditorious* wretch! what hast thou done,  
 To make this barb'rous base assassinate? *Daniel.*

PRODUCE, *v. a. & n. s.* } Fr. *produire*;  
 PRODUCENT, *n. s.* } Lat. *produco*. To  
 PRODUCER, } exhibit or offer to  
 PRODUCIBLE, *adj.* } notice; bring for-  
 PRODUCIBLENESS, *n. s.* } ward; bear; bring  
 PRODUCT, *n. s.* } forth; cause; id-  
 PRODUCTION, } get; generate;  
 PRODUCTIVE, *adj.* } effect: as a noun

substantive, that which is produced; amount;  
 profit: producent and producer mean, one that  
 offers or exhibits; one that generates or brings  
 forth: producible, such as may be exhibited;  
 may be made or generated: product, something  
 yielded by nature; composition; work; effect;  
 result; sum: production, the act of producing,  
 or thing produced: productive, having efficient  
 or generative power; fruitful.

Produce your cause, saith the Lord: bring forth  
 your strong reasons. *Isaiah xli. 21.*  
 This soil produces all sorts of palm trees.  
*Sandys.*

It seems not meet, nor wholesome to my place,  
 To be produced against the Moor. *Shakspeare.*  
 Somewhat is produced of nothing; for lyes are  
 sufficient to breed opinion, and opinion brings on  
 substance. *Bacon.*

By examining how I, that could contribute no-  
 thing to mine own being, should be here, I came  
 to ask the same question for my father, and so am  
 led in a direct line to a first producer that must be  
 more than man. *Suckling.*

Many warm expressions of the fathers are pro-  
 ducible in this case. *Decay of Pietu.*

There is no reason producible to free the Christian  
 children and idiots from the blame of not believing,  
 which will not with equal force be producible for  
 those heathens to whom the gospel was never re-  
 vealed. *Hammond.*

They by imprudence mixed  
Produce prodigious births of body or mind.

Milton.

Thou all this good of evil shalt produce. *Id.*

These are the product

Of those ill-mated marriages. *Id. Paradise Lost.*

In thee,

Not in themselves, all their known virtue appears  
Productive as in herb and plant.

Milton.

The best of queens and best of herbs we owe

To that bold nation, which the way did show

To the fair region, where the sun does rise,

Whose rich productions we so justly prize.

Waller.

The salts *producibile*, are the alcalis or fixed salts,  
which seem to have an antipathy with acid ones.

Boyle.

To confirm our doctrine of the *producibleness* of  
salts. Helmont assures us that, by Paracelsus's *sal*  
*circulatum*, solid bodies, particularly stones, may  
be transmuted into actual salt equiponderant. *Id.*

You hoard not health for your own private use,  
But on the publick spend the rich produce.

Dryden.

A painter should foresee the harmony of the lights  
and shadows, taking from each of them that which  
will most conduce to the production of a beautiful  
effect. *Id.*

Be thou my aid, my tuneful song inspire,

And kindle with thy own productive fire. *Id.*

(Observing in ourselves, that we can at pleasure  
move several parts of our bodies; the effects also,  
that natural bodies are able to produce in one another,  
occurring every moment to our senses, we both  
these ways get the idea of power. *Locke.*

Whenever want of money, or want of desire in the  
consumer, makes the price low, that immediately  
reaches the first producer. *Id.*

The landholder, having nothing but what the  
product of his land will yield, must take the market-  
rate. *Id.*

In Staffordshire, after their lands are marled, they  
sow it with barley, allowing three bushels to an  
acre. Its common produce is thirty bushels.

Mortimer's Husbandry.

If the productive fat of the marl be spent, it is  
not capable of being mended with new. *Mortimer.*

Rain in the same quarter the products of the  
same season. *Spectator.*

This is turning nobility into a principle of virtue,  
and making it productive of merit, as it is understood  
to have been originally a reward of it. *Id.*

That is accounted probable which has better argu-  
ments producible for it, than can be brought against  
it. *South.*

This wonder of the sculptor's hand

Produced, his art was at a stand. *Addison.*

This tax has already been so often tried, that we  
know the exact produce of it. *Id. Freeholder.*

Our British products are of such kinds and quanti-  
ties, as can turn the balance of trade to our advan-  
tage. *Addison.*

It as instrument be produced with a prostration  
to favour of the producer, and the adverse party does  
not contradict, it shall be construed to the advantage  
of the producer. *Ayliffe.*

See thy bright altars

Heap'd with the products of Sabeau springs. *Pope.*

Hymen's flames like stars unite,

And burn for ever one;

Chaste as cold Cynthia's virgin light

Productive as the sun. *Id.*

Your parents did not produce you much into the  
world, whereby you avoided many wrong steps.

Swift.

We have had our names prefixed at length to  
whole volumes of mean productions. *Id.*

Numbers of Scots are glad to exchange their barren  
hills for our fruitful vales so productive of that grain.

*Id.*

Plutarch in his life of Theseus, says, that that  
age was productive of men of prodigious stature.

Broome.

Most of those books which have obtained great  
reputation in the world are the products of great and  
wise men. *Watts.*

It is generally known that he who expects much  
will be often disappointed; yet disappointment sel-  
dom cures us of expectation, or has any other effect  
than that of producing a moral sentence or peevish  
exclamation. *Johnson.*

PRO'EM, *n. s.* Old Fr. *proëme*; Lat. *pro-*  
*æmium*; Gr. *προοίμιον*. Preface; introduction.

One and the same *proem*, containing a general  
motive to provoke people to obedience of all and  
every one of these precepts, was prefixed before the  
decalogue. *White.*

So glozed the tempter, and his *proem* tuned.

Milton.

Justinian has, in the *proem* to the digests, only  
prefixed the term of five years for studying the laws.

Ayliffe.

Thus much may serve by way of *proem*,

Proceed we therefore to our poem.

Swift's Miscellanies.

PROETIDES, in fabulous history, the daugh-  
ters of Proetus, king of Argos; who, preferring  
themselves to Juno, were struck with insanity,  
and believed themselves to be turned into cows.  
They soon infected the rest of the Argian women,  
but were cured by Melampus, who received one  
of these princesses, and two-thirds of Argos, for  
his reward. See MELAMPUS. Their names were  
Lysippe, Iphinoe or Ipponoe, and Iphianassa,  
or Cyrianassa.

PROETUS, in fabulous history, a king of  
Argos; the son of Abas and Ocalea, and twin  
brother of Acrisius, with whom he is said to have  
quarrelled even in the womb. Their dissensions  
increased with their years, and, on Abas's death,  
they contended for the kingdom; but, Acrisius  
prevailing, Proetus retired to Iobates, king of  
Lycia, whose daughter, Sthenoboea, he married,  
by whom he had Megapenthes, and the Proe-  
tides. By Iobates's assistance, he took Tiryntus.  
Homer. *Iliad. vi.*

PROFANE', *adj. & v. a.* Fr. *profane*; Lat.  
PROFANATION, } *profanus*. Irrever-  
PROFANELY, } rent to sacred  
PROFANER, *n. s.* } things; polluted;  
PROFANENESS, *n. s.* } impure; not sac-  
cred: to pollute; violate; wrongly use: profana-  
tion, the act or habit of violating or treating  
irreverently things sacred: the adverb and other  
noun substantives corresponding.

Pity the temple profaned of ungodly men.

2 Maccabees.

He knew how bold men are to take even from God  
himself; how hardly that house would be kept from  
impious profanation he knew. *Hooker.*

The argument which our Saviour useth against  
profanation of the temple, he taketh from the use  
whereunto it was with solemnity consecrated. *Id.*

Profane fellow!

Were thou the son of Jupiter, and no more  
But what thou art besides, thou wert too base  
To be his groom. *Shakespeare. Cymbeline.*

He then, that is not furnished in this sort,  
Doth but usurp the sacred name of knight,  
*Profaning* this most honourable order.

*Shakspeare.*

I feel me much to blame,  
So idly to *profane* the precious time. *Id.*  
(Great men may jest with saints, 'tis wit in them :  
But, in the less, foul *profanation*. *Id.*

Rebellious subjects, enemies to peace,  
*Profaners* of this neighbour-stained steel. *Id.*

Apollo, pardon  
My great *profaneness* 'gainst thy oracle ! *Id.*  
Nothing is *profane* that serveth to holy things.  
*Raleigh.*

'Twere *profanation* of our joys,  
To tell the laity our love. *Donne.*  
Let none of things serious, much less of divine,  
When belly and head's full, *profanely* dispute.  
*Ben Jonson.*

*Profanation* of the Lord's day, and of other solemn  
festival days, which are devoted to divine and reli-  
gious offices, is impious. *White.*

Foretasted fruit  
*Profaned* first by the serpent, by him first  
Made common and unhalloved. *Milton.*

Far hence be souls *profane*.  
The Sibyl cried, and from the grove abstain.  
*Dryden.*

How far have we  
*Profaned* thy heavenly gift of poesy !  
Made prostitute and profligate the muse,  
Debased. *Id.*

You can banish from thence scurrility and *pro-  
faneness*, and restrain the licentious insolence of  
poets and their actors. *Id.*

Others think I ought not to have translated  
Chaucer : they suppose a veneration due to his old  
language, and that it is little less than *profanation* and  
sacrilege to alter it. *Id.*

How are festivals *profaned* ? When they are not  
regarded, nor distinguished from common days ;  
when they are made instruments of vice and vanity ;  
when they are spent in luxury and debauchery ; when  
our joy degenerates into sensuality, and we express  
it by intemperance and excess. *Nelson.*

The universality of the deluge is attested by *pro-  
fane* history ; for the fame of it is gone through the  
earth, and there are records or traditions concerning  
it in all parts of this and the new found world.  
*Burnet's Theory.*

These have caused the weak to stumble, and the  
*profane* to blaspheme, offending the one, and harden-  
ing the other. *South.*

All *profanation* and invasion of things sacred is  
an offence against the eternal law of nature. *Id.*

There are a lighter ludicrous sort of *profaners*, who  
use the scripture to furnish out their jests.

*Government of the Tongue.*  
Edicts against immorality and *profaneness*, laws  
against oaths and execrations, we trample upon.  
*Atterbury.*

That proud scholar, intending to erect altars to  
Virgil, speaks of Homer too *profanely*. *Broome.*

**PROFECTION**, *n. s.* Lat. *profectio*. Ad-  
vance ; progression.

This, with *profection* of the horoscope unto the  
seventh house or opposite signs, every seventh year  
oppreseth living creatures. *Broune.*

PROFESS, *v. a. & v. n.* } Fr. *professer* ;  
PROFESS'EDLY, *adv.* } Lat. *professus*. To  
PROFESS'IONAL, *n. s.* } declare or make an  
PROFESS'IONAL, *adj.* } open show of  
PROFESS'OR, *n. s.* } opinion respecting  
PROFESS'OR-SHIP. } any thing ; assert

one's skill in any art or science ; to declare  
openly ; enter on a state of life by a public pro-  
fession ; declare friendship : *professedly* is,  
declaratively ; according to one's own declara-  
tion : profession, declaration ; act of declaring  
one's own party or opinion ; calling ; known  
pursuit ; technically distinguished from a trade,  
and applied to divinity, physic, and law, as vo-  
cations : professional, relating to, or befitting a  
profession : professor, one who publicly declares  
himself of a particular party or opinion ; or pub-  
licly teaches an art or science : professorship, his  
station or office.

*Profess* unto the Lord, that I am come unto the  
country which the Lord sware unto our fathers.

*Deut. xxvi. 3.*

They *profess* that they know God, but in works  
they deny him. *Titus i. 16.*

The *professions* of princes, when a crown is the  
bait, are a slender security. *Lesley.*

Love well your father :

To your *professing* bosoms I commit him.  
*Shakspeare.*

The day almost itself *professes* yours,  
And little is to do. *Id. Macbeth.*

Would you have me speak after my custom,  
As being a *professed* tyrant to their sex ?  
*Shakspeare.*

As he does conceive,

He is dishonoured by a man, which ever  
*Professed* to him ; why, his revenges must  
In that be made more bitter. *Id.*

I must tell you

You tender more your person's honour, than  
Your high *profession* spiritual. *Id.*

If we confound arts with the abuse of them, we  
shall condemn all honest trades ; for there are that  
deceive in all *professions*, and bury in forgetfulness all  
knowledge. *Raleigh.*

When the holiness of the *professors* of religion is  
decayed, you may doubt the springing up of a new  
sect. *Bacon's Essays.*

But Purbeck, as *profess* a huntress and a nun,  
The wide and wealthy sea, nor all his pow'r respects.  
*Drayton.*

I could not grant too much to men, that, being  
*professedly* my subjects, pretended religious strictness.

*King Charles.*

An ill Christian is the worst of all men ; an ill  
*professor* the worst of all Christians ; an ill minister  
the worst of all *professors*. *Bp. Hall.*

The whole church of *professors* at Philippi to whom  
he writes was not made up wholly of the elect, sin-  
cere, and persevering Christians, but like the net, in  
Christ's parable, that caught both good and bad, and  
had no doubt some insincere persons, hypocrites, and  
temporaries in it. *Hammond.*

Pretending first

Wise to fly pain, *professing* next the spy.  
*Milton.*

A naked *profession* may have credit, where no  
other evidence can be given. *Glanville's Serpis.*

Dr. Prideaux succeeded him in the *professorship* ;  
being then elected bishop of Worcester ; Sanderson  
succeeded him in the regius *professorship*. *Wotton.*

For by oil in their lamps, and the first lighting  
of them which was common to them both, is  
meant that solemn *profession* of faith and repent-  
ance, which all christians make in baptism.  
*Tillotson.*

A servant to thy sex, a slave to thee.

A foe *profess* to barren chastity. *Druden.*  
Virgil, whom he *professedly* imitated, has surpassed  
him among the Romans. *Id.*

Ordinary illiterate people, who were *professors*, that shewed a concern for religion, seem'd much conversant in St. Paul's epistles. *Locke.*

Let no man that *professes* himself a christian, keep so heathenish a family, as not to see God be daily worshipp'd in it. *Duty of Man.*

No other one race, not the sons of any one other *profession*, not perhaps altogether, are so much scattered amongst all *professions*, as the sons of clergymen. *Sprat's Sermons.*

England I travelled over, *professedly* searching all places as I passed along. *Woodward.*

Some of our *profession* keep wounds tented. *Wise man.*

Most profligately false, with the strongest *profession* of sincerity. *Swift.*

*Professors* in most sciences are generally the worst qualified to explain their meanings to those who are not of their tribes. *Id.*

This is a practice in which multitude, besides those of the learned *professions*, may be engaged. *Watts.*

*Professional*, as well as national, reflections are to be avoided. *Clarissa.*

A PROFESSOR, in the universities, is a person who teaches or reads public lectures in some art or science from a chair for the purpose.

PROFFER, v. a. & n. s. } Fr. *proferer* ;  
PROFFERER, n. s. } Lat. *profero*. To

propose; offer to acceptance; attempt: essay; offer or attempt made: he who offers.

He seide han ye here ony thing that schal be etun? And they *profferid* to him a part of a fish roostyd, and a honeycomb. *Wiclif. Luke 24.*

Basilus, content to take that, since he could have no more, allowed her reasons, and took her *proffer* thankfully. *Sidney.*

To them that covet such eye-glutting gain, *Proffer* thy gifts, and fitter servants entertain. *Spenser.*

*Proffers*, not took, reap thanks for their reward. *Shakespeare.*

Maids, in modesty, say no, to that which they would have the *profferer* construe ay. *Id.*

It is done with time, and by little and little, and with many essays and *proffers*. *Bacon's Essays.*

The king Great *proffers* sends of pardon and of grace; If they would yield, and quietness embrace. *Daniel.*

He made a *proffer* to lay down his commission of command in the army. *Clarendon.*

None, among the choice and prime Of those heaven-warring champions, could be found So hardy as to *proffer*, or accept, Alone, the dreadful voyage. *Milton's Paradise Lost.*

But these, nor all the *proffers* you can make, Are worth the heifer which I set to stake. *Dryden.*

Does Cato send this answer back to Cæsar, For all his generous cares and *proffered* friendship? *Addison.*

He who always refuses, taxes the *profferer* with indiscretion, and declares his assistance needless. *Collier.*

The parent pair their secret homage pay,  
And *proffer* up to heaven the warm request—  
That He who stills the raven's clamorous nest,  
And decks the lily fair in flowery pride,  
Would, in the way his wisdom sees the best,  
For them and for their little ones provide;  
But chiefly in their hearts with grace divine preside. *Burns.*

A weel-stocked mailen, himsel for the laird.

And marriage aff-hand, were his *proffers*:

I never loot on that I kenn'd it, or card,

But thought I might hae waur offers, waur offers,

But thought I might hae waur offers. *Id.*

For when one near displayed the absolving cross,  
And *proffered* to his touch the holy bead,

Of which his parting soul might own the need,

He looked upon it with an eye profane,

And smiled—Heaven pardon! if 'twere with disdain. *Byron.*

PROFICIENCE, n. s. } Lat. *proficio*. Pr.  
PROFICIENCY, } fit; advancement,  
PROFICIENT. } improvement  
gained: a proficient is, he who progresses or advances in any study or pursuit.

I am so good a proficient in one quarter of an hour, that I can drink with any tinker in his own language. *Shakespeare.*

I am disposed to receive further light in this matter, from those whom it will be no disparagement for much greater *proficients* than I to learn. *Boyle.*

Persons of riper years, who flocked into the church during the three first centuries, were obliged to pass through instructions, and give account of their *proficiency*. *Addison.*

Some reflecting with too much satisfaction on their own *proficiencies*, or presuming on their election by God, persuade themselves into a careless security *Rogers's Sermons.*

Young deathlings were, by practice made *Proficients* in their fathers' trade. *Swift.*

PROFICUOUS, adj. Lat. *proficuus*. Advantageous; useful.

It is very *proficuous* to take a good large dose. *Harvey.*

To future times *Proficuous*, such a race of men produce,  
As in the cause of virtue firm, may fix  
Her throne inviolate. *Philips.*

PROFILE, n. s. Fr. *profile*. The side face; half face.

The painter will not take that side of the face which has some notorious blemish in it; but either draw it in *profile*, or else shadow the more imperfect side. *Dryden.*

Till the end of the third century, I have not seen a Roman emperor drawn with a full face: they always appear in *profile*, which gives us the view of a head very majestic. *Addison.*

PROFILE, in architecture, is the draught of a building, fortification, &c., wherein are expressed the several heights, widths, and thicknesses, such as they would appear were the building cut down perpendicularly from the roof to the foundation. Whence the profile is also called the section, sometimes orthographical section.

PROFILE, in sculpture and painting. A head, a portrait, &c., are said to be in *profile*, when they are represented sidewise, or in a side view; as, when in a portrait there is but one side of the face, one eye, one cheek, &c., shown, and nothing of the other. On almost all medals, the faces are represented in *profile*.

PROFIT, n. s., v. a., & v. n. } Fr. *profit*,  
PROFITABLE, adj. } *profiter*; Ital.  
PROFITABLY, adv. } *profitto*; Lat.  
PROFITABLENESS, n. s. } *profitus*.  
PROFITLESS, adj. } Gain; advan-



**tage**; proficiency: to benefit, improve, or advance; to gain advantage or improvement; be of use or advantage: profitable is, gainful, advantageous, lucrative; the adverb and noun substantive corresponding: profitless, worthless; without advantage or recompense.

Whereto might the strength of their hands *profit* me? *Job*.

Wisdom that is hid, and treasure that is hoarded up, what *profit* is in them both? *Eccles. xx. 30.*

Meditate upon these things, give thyself wholly to them, that thy *profiting* may appear to all.

*1 Tim.*

Then Judas, thinking indeed that they would be *profitable* in many things, granted them peace.

*2 Mac. xii.*

Thou must know

'Tis not my *profit* that does lead mine honour.

*Shakspeare.*

A pound of man's flesh, taken from a man,

Is not so estimable or *profitable*,

As flesh of muttons, beefs, or goats.

*Id.*

We must not think the Turk is so unskilful,

To leave that latest, which concerns him first;

Neglecting an attempt of ease and gain,

To wake and wage a danger *profitless*.

*Id.*

The king did not love the barren wars with Scotland, though he made his *profit* of the noise of them.

*Bacon.*

The planting of hop-yards, sowing of wheat and rape-seed, are found very *profitable* for the planters, in places apt for them, and consequently *profitable* for the kingdom.

*Id.*

Let it *profit* thee to have heard,

By terrible example, the reward

Of disobedience. *Milton's Paradise Lost.*

We will now briefly take notice of the *profitable*-ness of plants for physic and food.

*More.*

'Tis a great means of *profiting* yourself, to copy diligently excellent pieces and beautiful designs.

*Dryden.*

What *profited* thy thoughts, and toils, and cares, In vigour more confirmed, and riper years? *Prior.*

What shall be the just portion of those, whom neither the condescension or kindness, nor wounds and sufferings of the Son of God could persuade, nor yet the excellency, easiness and *profitableness* of his commands invite? *Calamy's Sermons.*

The Romans, though possessed of their ports, did not *profit* much by trade.

*Arbuthnot on Coins.*

What was so *profitable* to the empire, became fatal to the emperor.

*Id.*

You have had many opportunities to settle this reflection, and have *profitably* employed them.

*Wake.*

He thinks it highly just, that all rewards of trust, *profit*, or dignity, should be given only to those whose principles direct them to preserve the constitution.

*Swift.*

**PROFLIGATE**, *adj., n. s.* } Lat. *profligatus*.

**PROFLIGATELY**, { & *v. a.* } Abandoned; lost

**PROFLIGATENESS**, *n. s.* } to virtue and decency; shameless: a rake; an abandoned wretch: Harvey uses the verb after the Lat. *profligo*, but has not been followed: the adverb and noun substantive correspond with the adjective in sense.

Lavatories, to wash the temples, hands, wrists, and jugulars, do potently *profligate* and keep off the venom.

*Harvey*

Time sensibly all things impairs; Our fathers have been worse than theirs, And we than ours; next age will see

A race more *profligate* than we,  
With all the pains we take, have still enough to be.  
*Roscommon.*

How far have we

Prophaned thy heavenly gift of poesy?

Made prostitute and *profligate* the muse,

Debased to each obscene and impious use,

Whose harmony was first ordained above

For tongues of angels, and for hymns of love.

*Dryden.*

Though Phalaris his brazen bull were there,

And he would dictate what he'd have you swear,

Be not so *profligate*, but rather chuse

To guard your honour, and your life to lose. *Id.*

It is pleasant to see a notorious *profligate* seized with a concern for his religion, and converting his spleen into zeal.

*Addison.*

I have heard a *profligate* offer much stronger arguments against paying his debts, than ever he was known to do against Christianity; because he happened to be closer pressed by the bailiff than the parson.

*Swift's Miscellanies.*

Most *profligately* false, with the strongest professions of sincerity.

*Id.*

How could such a *profligate* as Antony, or a boy of eighteen like Octavius, ever dare to dream of giving the law to such an empire and people?

*Swift.*

Melancholy objects and subjects will, at times, impress the most *profligate* spirits.

*Clarissa.*

**PROFLUENCE**, *n. s.* } Lat. *profluens*. **PROFLUENT**, *adj.* } gress; course: flowing forward.

In the *profluence* or proceedings of their fortunes there was much difference between them.

*Wotton.*

Teach all nations what of him they learned,

And his salvation; them who shall believe

Baptizing in the *profluent* stream, the sign

Of washing them from guilt of sin.

*Milton.*

**PROFOUND**, *adj., n. s. & v. n.* } Fr. *profond*;

**PROFOUNDLY**, *adv.* } Lat. *profundus*. Deep;

**PROFOUNDNESS**, *n. s.* } far below the

**PROFUNDITY**.

surface; intellectually deep; learned; skilful; cunning; lowly; humble: the deep or main sea; the abyss: as a verb, a barbarism, meaning to dive or penetrate: the adverb corresponds with the adjective: profoundness and profundity mean depth of place, knowledge, or thought.

The revolters are *profound* to make slaughter, though I have been a rebuker of them. *Hosou v. 2.*

God, in the fathomless *profound*,

Hath all his choice commanders drowned.

*Sundys.*

Their wits, which did every where else conquer hardness, were with *profoundness* here overmatched.

*Hooker.*

Not orators only with the people, but even the very *profoundest* disputers in all faculties, have hereby often, with the best learned, prevailed most.

*Id.*

Upon the corner of the moon,

There hangs a vapourous drop *profound*.

*Shakspeare.*

The most *profoundly* wise.

*Drayton.*

What words wilt thou use to move thy God to hear thee? what humble gestures? what *profound* reverence?

*Duppa.*

All else deep snow and ice,

A gulf *profound*, as that Serbonian bog

Betwixt Damiat and mount Casius old. *Milton.*

If some other place the' ethereal king

Possesses lately, thither to arrive,

I travel this *profound*. *Id. Paradise Lost.*

The other turned

Round, through the vast *profundity* obscure.

*Milton.*

We cannot *profound* into the hidden things of nature, nor see the first springs that set the rest a-going.

*Glanville.*

Now I die absent in the vast *profound* ;  
And me without myself the seas have drowned.

*Dryden.*

The virgin started at her father's name,  
And sighed *profoundly*, conscious of the shame. *Id.*  
*Domenichino* was *profoundly* skilled in all the parts of painting ; but, wanting genius, he had less of nobleness. *Id.*

Deep learned in the philosophy of heaven,  
He searched the causes out of good and ill,  
*Profoundly* calculating their effects  
Far past the bounds of time. *Pollbk.*

**PROFUSE**, *adj.* } Lat. *profusus*. Lavish ;  
**PROFUSE**'LY, *adv.* } prodigal ; liberal to licen-  
**PROFUSE**'NESS, *n. s.* } tiousness ; exuberant : the  
**PROFUSION**. } adverb corresponding :

*profuseness* is lavishness ; prodigality ; extravagance : profusion, abundance ; exuberant plenty ; also lavish or extravagant expense.

He was desirous to avoid not only *profusion*, but the least effusion of Christian blood. *Hayward.*

The great *profusion* and expence  
Of his revenues bred him much offence. *Daniel.*

On a green shady bank, *profuse* of flowers,  
Pensive I sat. *Milton's Paradise Lost.*

*Profuseness* of doing good, a soul unsatisfied with all it has done, and an unextinguished desire of doing more. *Dryden.*

In *profuse* governments it has been ever observed that the people, from bad example, have grown lazy and expensive, the court has become luxurious and wantonly, and the camp insolent and seditious.

*Lavenant.*

What meant thy pompous progress through the empire ?

Thy vast *profusion* to the factious nobles ? *Rance.*

Oh liberty, thou goddess heavenly bright,

*Profuse* of bliss, and pregnant with delight.

*Addison.*

Trade is fitted to the nature of our country, as it abounds with a great *profusion* of commodities of its own growth, very convenient for other countries.

*Id.*

Hospitality sometimes degenerates into *profuseness*, and ends in madness and folly. *Atterbury.*

Then spring the living herbs *profusely* wild.

*Thomson.*

The raptured eye,

The fair *profusion*, yellow Autumn spies. *Id.*

The prince of poets, who before us went,

Had a vast income, and *profusely* spent. *Harte.*

**PROG**, or **PRIG**, *v. n. & n. s.* Goth. *trigda*.

To rob ; steal ; pilfer ; shift meanly for provisions ; victuals ; food. A low word.

She went out *progging* for victuals as before.

*L'Estrange.*

Spouse met up doth in pattens trudge it,

With handkerchief of *prog*, like trull with budget ;

And eat by turns plumcake and judge it. *Congreve.*

O nephew ! your grief is but folly,

In town you may find better *prog*.

*Saunders's Miscellanies.*

**PROGENITOR**, *n. s.* } Lat. *progenitus*. A

**PROGENY**. } forefather ; ancestor

in a direct line : progeny is offspring ; race ;

*nov.*

Although these things be already past away by her *progenitor's* former grants unto these lords, yet I could find a way to remedy a great part thereof.

*Spenser's State of Ireland.*

The sons of God have God's own natural Son as a second Adam from heaven, whose race and *progeny* they are by spiritual and heavenly birth.

*Hooker.*

Like true subjects, sons of your *progenitors*,  
Go cheerfully together. *Shakspeare.*

Not me begotten of a shepherd's swain,

But issued from the *progeny* of kings. *Id.*

Oh ! admirable temperance, worthy the *progenitor* of him, in whose lips or heart was no guile.

*Bp. Hall*

All generations then had hither come,  
From all the ends of the earth, to celebrate  
And reverence thee, their great *progenitor*.

*Milton.*

By promise he receives

Gift to his *progeny* of all that land. *Id.*

Thus shall we live in perfect bliss, and see,

Deathless ourselves, a numerous *progeny*.

*Dryden.*

Power by right of fatherhood is not possible in any one, otherwise than as Adam's heir, or as *progenitor* over his own descendants. *Locke.*

The principal actors in Milton's poems are not only our *progenitors*, but representatives. *Addison.*

We are the more pleased to behold the throne surrounded by a numerous *progeny*, when we consider the virtues of those from whom they descend.

*Id. Freeholder.*

**PROGNOSTIC**, *adj. & n. s.* } Fr. *prognos-*

**PROGNOSTICABLE**, *adj.* } *tique* ; Gr.

**PROGNOSTICATE**, *v. a.* } *προγνωστικός*

**PROGNOSTICATION**, *n. s.* } Foretelling or

**PROGNOSTICATOR**. } foreshowing ;

applied particularly to foreshowing health or disease : a prediction or token, and (gallicism) the skill of foretelling diseases : prognosticable is such as may be foreshown or fore-known : prognosticate, to foretel ; foreshow : prognostication, the act of doing so, or the token, sentence, or determination given : prognosticator he who gives it forth.

He bid him farewell, arming himself in a black armour, as a badge or *prognostication* of his mind.

*Sidney.*

If an oily palm be not a fruitful *prognostication* I cannot scratch mine ear.

*Shakspeare. Antony and Cleopatra.*

He had now outlived the day which his tutor Sandford had *prognosticated* upon his nativity he would not outlive. *Clarendon.*

The causes of this inundation cannot be regular, and therefore their effects not *prognosticable* like eclipses. *Browne's Vulgar Errors.*

Unskilled in schemes by planets to foreshow,

I neither will, nor can *prognosticate*,

To the young gaping heir, his father's fate.

*Dryden.*

This theory of the earth begins to be a kind of prophecy or *prognostication* of things to come, as it hath been hitherto an history of things past.

*Burnet.*

Whatever you are or shall be, has been but an easy *prognostic* from what you were. *South.*

There is nothing so inconsiderable, which may not appear dreadful to imagination, that is filled with omens and *prognostics*. *Addison.*

That astrologer made his almanack give a tolerable account of the weather by a direct inversion of

the common prognosticators, to let his belief run counter to reports. *Government of the Tongue.*

Hippocrates's prognostic is generally true, that it is very hard to resolve a small apoplexy. *Arbuthnot.*

Careful observers

By sure prognostics may foretel a shower. *Swift.*

PROGRESS, *n. s. & v. n.* } Fr. *progrés*; Latin *progressus*.  
 PROGRESSION, *n. s.* }  
 PROGRESSIONAL, *adj.* } Course; passage;  
 PROGRESSIVE, } procession; advancement; improvement: to  
 PROGRESSIVELY, *adv.* }  
 PROGRESSIVENESS, *n. s.* }  
 pass; move forward: progression and progressiveness are synonymous with progress as a noun substantive: progressional, in a state of increase or advance: progressive, advancing; going forward; the adverb corresponding.

I cannot, by the progress of the stars,  
 Give guess how near to day.

*Shakespeare. Julius Caesar.*

Let me wipe off this honourable dew,  
 That silverly doth progress on thy cheeks.

*Shakespeare.*

He hath framed a letter, which accidentally, or by the way of progression, hath miscarried. *Id.*

Out of Ethiopia beyond Egypt has been a strange progress for ten hundred thousand men. *Raleigh.*

Princes, if they use ambitious men, should handle it so as they may be still progressive, and not retrograde. *Bacon.*

He gave order that there should be nothing in his journey like unto a warlike march, but rather like unto the progress of a king in full peace. *Id.*

Solon the wise his progress never ceased,  
 But still his learning with his days increased.

*Denham.*

From Egypt arts their progress made to Greece,  
 Wrought in the fable of the golden fleece. *Id.*

The morn begins

Her rosy progress smiling. *Milton.*

Their course

Progressive, retrograde, or standing still. *Id.*

Those worthies, who endeavour the advancement of learning are likely to find a clearer progression, when so many rubs are levelled. *Browne.*

Thus { 2, 4, 6, 8, 10, &c. increasing } by the difference 2.  
 { 10, 8, 6, 4, 2, &c. decreasing }

PROGRESSION, GEOMETRICAL, OR CONTINUED GEOMETRIC PROPORTION, is when the terms do increase or decrease by equal ratios: thus,

2, 4, 8, 16, 32, 64, increasing } from a continual { multiplication } by 2.  
 64, 32, 16, 8, 4, 2, decreasing } { division }

PROHIBIT, *v. a.* } Fr. *prohiber*; Lat. *prohibeo*. To forbid;  
 PROHIBITION, *n. s.* } *prohibeo*. To forbid;  
 PROHIBITORY, *adj.* } interdicit; hinder; debar: the noun substantive and adjective corresponding.

She would not let them know of his close lying in that prohibited place, because they would be offended. *Sidney.*

The weightiest, which it did command them, are to us in the gospel prohibited. *Hooker.*

Might there not be some other mystery in this prohibition, than they think of? *Id.*

'Gainst self-slaughter

There is a prohibition so divine,  
 That cravens my weak hand.

*Sickopure. Cymbeline.*

They maintain their accomplished ends, and relapse not again into their progressional imperfections. *Id.*

In progressive motion, the arms and legs move successively; but, in natation, both together. *Id. Vulgar Errours.*

The reason why they fall in that order, from the greatest epacts progressively to the least, is, because the greatest epacts denote a greater distance of the moon before the sun, and consequently a nearer approach to her conjunction. *Holder.*

It is impossible the mind should ever be stopped in its progress in this space. *Locke.*

In philosophical enquiries, the order of nature should govern, which in all progression is to go from the place one is then in, to that which lies next to it. *Id.*

The progressive motion of this animal is made not by walking, but by leaping. *Ray on the Creation.*

Whosoever understands the progress and revolutions of nature, will see that neither the present form of the earth, nor its first form, were permanent and immutable. *Burnet.*

O may I live to hail the day,

When the glad nation shall survey

Their sov'reign, through his wise command,

Passing in progress o'er the land. *Addison.*

Ere the progressive course of restless age

Perform three thousand times its annual stage,

May not our power and learning be suppress'd,

And arts and empire learn to travel west? *Prior.*

The squares of the diameters of these rings, made by any prismatic color, were in arithmetical progression. *Newton.*

The Sylphs behold it kindling as it flies,

And pleased pursue its progress through the skies. *Pope.*

Perhaps I judge hastily, there being several, in whose writings I have made very little progress. *Swift's Miscellanies.*

You perhaps have made no progress in the most important Christian virtues; you have scarce gone half way in humility and charity. *Law.*

PROGRESSION, in mathematics, is either arithmetical or geometrical.

PROGRESSION, ARITHMETICAL, OR CONTINUED ARITHMETIC PROPORTION, is, where the terms do increase and decrease by equal differences, and is called arithmetical progression:

He bestowed the liberal choice of all things, with one only prohibition, to try his obedience. *Hobbes.*

Moral law is two-fold; simply moral, or moral only by some external constitution, or imposition of God. Divine law, simply moral, commandeth or prohibiteth actions, good or evil, in respect of their inward nature and quality. *White.*

Let us not think hard

One easy prohibition, who enjoy

Free leave so large to all things else. *Milton.*

Gates of burning adamant

Barred over us, prohibit all egress. *Id.*

The law of God in the ten commandments consists mostly of prohibitions; thou shalt not do such a thing. *Talbotson.*

A prohibition will lie on this statute, notwithstanding the penalty annexed; because it has words *prohibitory*, as well as a penalty annexed. *Ayliffe*.

PROJECT, *v. a., v. n. & n. s.* } Fr. *projeter*;  
 PROJECTILE, *n. s. & adj.* } Lat. *projicio*,  
 PROJECTION, *n. s.* } *projectus*. To  
 PROJECTOR, *n. s.* } throw or cast

out; cast forward; exhibit as in the manner of an image on a mirror; form in the mind; contrive; scheme: a scheme; design; contrivance: a projectile is a body put into motion: as an adjective it means impelled forward: projection is the act of shooting forwards; plan; scheme; crisis of a chemical operation; projector, one who forms schemes or designs; a mere schemer.

A little quantity of the medicine in the *projection* will turn a sea of the baser metal into gold by melting. *Bacon*.

It cases to be counsel, to compel men to assist to whatever tumultuary patrons shall *project*. *King Charles*.

What sit we then *projecting* peace and war? *Milton*.

If the electric be held unto the light, many particles will be discharged from it, which motion is performed by the breath of the effluvium issuing with agility; for, as the electric cooleth, the *projection* of the atoms ceaseth. *Brown*.

Invasive of themselves where e'er they pass,  
 They make that warmth in others they expect;  
 Their valour works like bodies on a glass,  
 And does its image on their men *project*. *Dryden*.

Chymists, and other *projectors*, propose to themselves things utterly impracticable. *L'Estrange*.

What desire, by which nature *projects* its own pleasure or preservation, can be gratified by another man's personal pursuit of his own vice? *South*.

It is a discovering the longitude, and deserves a much higher name than that of a *project*. *Addison*.

The following comes from a *projector*, a correspondent as diverting as a traveller; his subject having the same grace of novelty to recommend it. *Id.*

In the various *projects* of happiness, devised by human reason, there appeared inconsistencies not to be reconciled. *Rogers*.

Among all the *projectors* in this attempt, none have met with so general a success as they who apply themselves to soften the rigour of the precept. *Id.*

Good blood, and a due *projectile* motion or circulation, are necessary to convert the aliment into laudable juices. *Arbuthnot*.

*Projectiles* would for ever move on in the same right line, did not the air, their own gravity, or the ruggedness of the plane stop their motion. *Cheyne's Philosophical Principles*.

The ascending villas

*Project* long shadows o'er the crystal tide. *Pope*.

Astrologers that future fates foreshow,  
*Projectors*, quacks, and lawyers not a few. *Id.*

If we had a plan of the naked lines of longitude and latitude, *projected* on the meridian, a learner might more speedily advance himself in the knowledge of geography. *Watts*.

For the bulk of the learners of astronomy, that *projection* of the stars is best, which includes in it all the stars in our horizon, reaching to the 38½ degree of the southern latitude. *Id.*

PROJECTILES.

PROJECTILES is a term under which has been comprehended that branch of mechanical philosophy which treats of the motion of bodies projected in any way from the surface of the earth, and influenced by the action of gravity. The principal application of this science in modern times, particularly in Europe, has been to gunnery, an art totally unknown to the ancients; yet they were far from being ignorant of other branches of this science. Machines were known among the Greeks and Romans by the names of *ballista*, *Catapulta*, &c., which produced effects by the elastic action of a strongly twisted cordage, and formed of tough animal substances, hardly less terrible than the artillery of the moderns; and the various tremendous engines of this kind, invented by the celebrated *Archimedes*, show to what considerable perfection the direction of projectiles had then been brought. See *ARCHIMEDES* and *ARTILLERY*. Such instruments continued in use down to the twelfth and thirteenth centuries, and the use of bows still longer; nor were they totally laid aside till they were superseded by the use of gunpowder and the modern ordnance.

The first application of gunpowder to military affairs was made, as we have shown in the article just referred to, early in the fourteenth century, the first pieces of artillery being charged with gunpowder and stone bullets of a prodigious size.

Thus, when Mahomet II. besieged Constantinople in 1543, he battered the walls with stones of this kind, and with pieces of the calibre of 1200 lbs.; which could not be fired more than four times a day. It was, however, soon discovered that iron bullets, of much less weight, would be more efficacious if impelled by quantities of stronger powder. This occasioned an alteration in the matter and form of the cannon, which were now cast of brass. These were lighter and more manageable than the former, and at the same time stronger in proportion to their bore.

By these means powder compounded in the manner now practised over all Europe came first in use. But the change of the proportion of materials was not the only improvement. The method of graining was of great advantage. The additional strength which the grained powder was found to acquire, from the free passage of the air between the grains, occasioned the meal powder to be entirely laid aside.

For the last 250 years the formation of cannon has been little improved; the best pieces of modern artillery differing little in their proportions from those used in the time of Charles V. Indeed lighter and shorter pieces have been often proposed and essayed; but, though they have advantages in particular cases, yet it seems now to be agreed that they are altogether insufficient.

for general service. On the whole, however, small pieces of artillery have been brought into use: thus the battering pieces now approved are the demi-cannon of former times; it being found that their stroke, though less violent than that of a larger piece, is yet sufficiently adapted to the strength of the usual profiles of fortification; and that the facility of their carriage and management, and the ammunition they spare, give them great advantages beyond the whole cannon formerly employed. The method of making a breach, by first cutting off the whole wall as low as possible before its upper part is attempted to be beaten down, seems also to be a considerable modern improvement. But the most important advance in this art is the method of firing with small quantities of powder, and elevating the piece so that the bullet may just go clear of the parapet of the enemy, and drop into his works. By these means the bullet, coming to the ground at a small angle, and with a small velocity, does not bury itself, but bounds or rolls along in the direction in which it was fired: and therefore, if the piece be placed in a line with the battery it is intended to silence, or the front it is to sweep, each shot rakes the whole length of that battery or front; and has thereby a much greater chance of disabling the defendants, and dismounting their cannon. This method was invented by Vauban, and was by him styled *Batterie à Ricochet*. It was first practised in 1692 at the siege of Aeth. Something similar was practised by the king of Prussia at the battle of Rosbach in 1757.

## PART I.

### THEORY OF PROJECTILES.

#### SECT. I.—OF THE EFFECTS OF GRAVITY ON PROJECTED BODIES.

It has been demonstrated that a body projected in the usual way from the surface of the earth in the atmosphere, must describe a conic section, having the centre of the earth in one focus, and that it will describe round that focus areas proportional to the times: it follows that, if the velocity of projection exceeds 36,700 feet in a second, the body (if not resisted by the air) would describe a hyperbola; if it be just 36,700 it would describe a parabola; and, if it be less, it would describe an ellipsis. If projected directly upwards, in the first case, it would never return, but proceed for ever; its velocity continually diminishing, but never becoming less than an assignable portion of the excess of the initial velocity above 36,700 feet in a second; in the second case it would never return, its velocity would diminish without end, but never be extinguished. In the third case, it would proceed till its velocity was reduced to an assignable portion of the difference between 36700 and its initial velocity; and would then return, regaining its velocity by the same degrees, and in the same places as it lost it. These are necessary consequences of a gravity directed to the centre of the earth, and inversely proportional to the square of the distance. But, in the greatest projections that we are able to make, the gravitations are so nearly equal, and in directions so

nearly parallel, that it would be ridiculous affectation to pay any regard to the deviations from equality and parallelism. A bullet rising a mile above the surface of the earth loses only  $\frac{1}{1000}$  of its weight, and a horizontal range of four miles only four of deviation from parallelism. Gravitation may be therefore assumed as equal and parallel. The errors arising from this assumption are quite insensible in all the uses which can be made of this theory; which was the first fruits of mathematical philosophy, and the effort of the genius of the great Galileo.

Gravity is a constant or uniform accelerating or retarding force, according as it produces the descent, or retards the ascent, of a body: and, all other forces being ascertained by the accelerations which they produce, they are conveniently measured by comparing their accelerations with the acceleration of gravity. This therefore has been assumed by all the latest and best writers on mechanical philosophy, as the unit by which every other force is measured. It gives a perfectly distinct notion of the force which retains the moon in its orbit, to say it is the 3600th part of the weight of the moon at the surface of the earth: i. e. if a bullet were here weighed by a spring steel-yard, and pulled it out to the mark 3600, if it were then taken to the distance of the moon, it would pull it out only to the mark 1. This assertion is made from observing that a body at the distance of the moon falls from that distance  $\frac{1}{16}$  part of sixteen feet in a second. Forces therefore which are imperceptible are not compared, but the accelerations, which are their indications, effects, and measures. For this reason philosophers have been anxious to determine with precision the fall of heavy bodies, to have an exact value of the accelerating power of terrestrial gravity. This measure may be taken in two ways; by taking the space through which the heavy body falls in a second; or the velocity which it acquires in consequence of gravity having acted on it during a second. The last is the proper measure; for the last is the immediate effect on the body. The action of gravity has changed the state of the body, by giving it a determination to motion downward: this both points out the kind and the degree or intensity of the force of gravity. The space described in a second by falling is not an invariable measure; for, in the successive seconds, the body falls through 16, 48, 80, 112, &c., feet, but the changes of the body's state in each second is the same. At the beginning it had no determination to move with any appreciable velocity; at the end of the first second it had a determination by which it would have gone on for ever (had no subsequent force acted on it) at the rate of thirty-two feet per second. At the end of the second second, it had a determination by which it would have moved for ever, at the rate of sixty-four feet per second. At the end of the third second, it had a determination by which it would have moved for ever, at the rate of ninety-six feet per second, &c. &c. The difference of these determinations is a determination to the rate of thirty-two feet per second. This is therefore constant, and the indication and proper measure of the constant or invariable

force of gravity. The space fallen through in the first second is of use only as it is one-half of the measure of this determination; and, as halves have the proportion of their wholes, different accelerating forces may be safely affirmed to be in the proportion of the spaces through which they uniformly impel bodies in the same time. But we must always recollect that this is but one-half of the true measure of the accelerating force. Mathematicians of the first rank have committed great mistakes by not attending to this; and it is necessary to notice it here, because cases will occur, in the prosecution of this subject, where we shall be very apt to confound our reasonings by a confusion in the use of those measures.

SECT. II.—OF THE MEASURE OF THE ACCELERATIVE POWER OF GRAVITY.

The accurate measure of the accelerative power of gravity is the fall  $16\frac{1}{2}$  feet, if measured by the space, or the velocity of  $32\frac{1}{2}$  feet per second, if the velocity be taken. It will greatly facilitate calculation, and will be sufficiently exact for every purpose, to take 16 and 32, supposing that a body falls sixteen feet in a second, and acquires the velocity of thirty-two feet per second. Then, because the heights are as the squares of the times, and as the squares of the acquired velocities, a body will fall one foot in one fourth of the time, and will acquire the velocity of eight feet per second. Let  $h$  express the height in feet, and call it the producing height;  $v$  the velocity in feet per second, and call it the produced velocity, the velocity due; and  $t$  the time in seconds.—The following formulæ, which are of easy recollection, will serve, without tables, to answer all questions relative to projectiles.

- I.  $v = 8 \sqrt{h}, = 8 \times 4 t, = 32 t$
- II.  $t = \frac{\sqrt{h}}{4}, = \frac{v}{32}$
- III.  $\sqrt{h} = \frac{v}{8}, = 4 t$
- IV.  $h = \frac{v^2}{64}, = 16 t^2$

To give some examples of their use, let it be required,

1. To find the time of falling through 256 feet. Here  $h = 256, \sqrt{256} = 16, \text{ and } \frac{16}{4} = 4$ . Answer 4'.
2. To find the velocity acquired by falling four seconds.  $t = 4 \cdot 32 \times 4 = 128$  feet per second.
3. To find the velocity acquired by falling 625 feet.  $h = 625 \cdot \sqrt{h} = 25 \cdot 8 \sqrt{h} = 200$  feet per second.
4. To find the height to which a body will rise when projected with the velocity of fifty-six feet per second, or the height through which a body must fall to acquire this velocity.  
 $v = 56 \cdot \frac{56}{8} = 7, = \sqrt{h} \cdot 7^2 = h, = 49$  feet.  
 or  $56^2 = 3136 \cdot \frac{3136}{64} = 49$  feet.
5. Suppose a body projected directly downwards with the velocity of ten feet per second; what will be its velocity after four seconds? In four seconds it will have acquired, by the action of gravity, the velocity of  $4 \times 32, \text{ or } 128$  feet,

and therefore its whole velocity will be 138 feet per second.

6. To find how far it will have moved, compound its motion of projection, which will be forty feet in four seconds, with the motion which gravity alone would have given it in that time, which is 256 feet; and the whole motion will be 296 feet.

7. Suppose the body projected as already mentioned, and that it is required to determine the time it will take to go 296 feet downwards, and the velocity it will have acquired. Find the height  $x$ , through which it must fall to acquire the velocity of projection, ten feet, and the time  $y$  of falling from this height. Then find the time  $z$  of falling through the height  $296 + x$ , and the velocity  $v$  acquired by this fall. The time of describing the 296 feet will be  $z - y$ , and  $v$  is the velocity required. From such examples it is easy to see the way of answering every question of the kind.

Writers on the higher parts of mechanics always compute the actions of other accelerating and retarding forces, by comparing them with the acceleration of gravity; and, to render their expressions more general, use a symbol, such as  $g$  for gravity, leaving the reader to convert it into numbers. Agreeably to this view, the general formulæ will stand thus:

- I.  $v = \sqrt{2gh}, \text{ i. e. } \sqrt{2} \sqrt{g} \sqrt{h}, = g t,$
- II.  $t = \frac{v}{g}, = \frac{\sqrt{4h}}{\sqrt{2g}}, = \sqrt{\frac{4h}{2g}}, = \sqrt{\frac{2h}{g}}$
- III.  $h = \frac{v^2}{2g}, = \frac{g t^2}{2}$

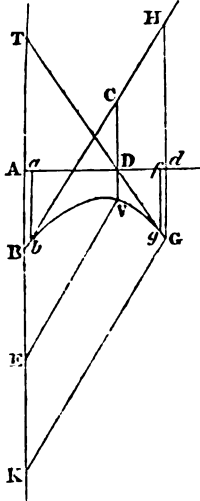
Gravity, or its accelerating power, is estimated in all these equations, as it ought to be, by the change of velocity which it generates in a particle of matter in a unit of time. But many mathematicians, in their investigations of curvilinear and other varied motions, measure it by the deflection which it produces in this time from the tangent of the curve, or by the increment by which the space described in a unit of time exceeds the space described in the preceding unit. This is but one-half of the increment which gravity would have produced, had the body moved through the whole moment with the acquired addition of velocity. In this sense of the symbol  $g$ , the equations stand thus:

- I.  $v = 2 \sqrt{gh}, = 2 g t$
- II.  $t = \sqrt{\frac{h}{g}}, = \frac{v}{2g}$
- IV.  $h = \frac{v^2}{4g}, = g t^2, \text{ and } \sqrt{h} = \frac{v}{2 \sqrt{g}}$

It is likewise very common to consider the accelerating force of gravity as the unit of comparison. This renders the expressions much more simple. In this way  $v$  expresses not the velocity, but the height necessary for acquiring it, and the velocity itself is expressed by  $\sqrt{v}$ . To reduce such an expression of a velocity to numbers, multiply it by  $\sqrt{2g}$ , or by  $2 \sqrt{g}$ , according as  $g$  is the generated velocity, or the space fallen through in the unit of time. This will suffice for the perpendicular ascents or descents of heavy bodies; and we proceed to con-

sider their motions when projected obliquely. The circumstance which renders this an interesting subject is, that the flight of cannon shot and shells are instances of such motion, and the art of gunnery must in a great measure depend on this doctrine. Let a body B (fig. 1) be projected in any direction, BC, not perpendicular to the horizon, and with any velocity. Let AB be the height producing this velocity; that is, let the velocity be that which a heavy body would acquire by falling freely through AB. It is required to determine the path of the body, and all the circumstances of its motion in this path?

Fig. 1.



1. By the continual action of gravity, the body will be continually deflected from the line BC, and will describe a curve line BVG, concave towards the earth.

2. This curve line is a parabola, of which the vertical line ABE is diameter, B the vertex of this diameter, and BC a tangent in B. Through any two points, VG, of the curve draw VC, GH, parallel to AB, meeting BC in C and H, and draw VE, GK, parallel to BC, meeting AB in E, K. It follows, from the composition of motions, that the body would arrive at the points V, G, of the curve in the same time that it would have uniformly described BC, BH, with the velocity of projection; or that it would have fallen through BE, BK, with a motion uniformly accelerated by gravity; therefore the times of describing BC, BH, uniformly, are the same with the time of falling through BE, BK. But, because the motion along BH is uniform, BC is to BH as the time of describing BC to the time of describing BH, which we may express thus,  $BC : BH = T, BC : T, BH = T, BE : T, BK$ . But, because the motion along BK is uniformly accelerated, we have  $BE : BK = T^2, BE : T^2, BK = BC^2 : BH^2 = EV^2 : KG^2$ ; therefore the curve BVG is such, that the abscissæ BE, BK, are as the squares of the corresponding ordinates EV, KG; that is, the curve BVG is a parabola, and BC, parallel to the ordinates, is a tangent in the point B.

3. If the horizontal line ADd be drawn through the point A, it is the directrix of the parabola. Let BE be taken equal to AB. The time of falling through BE is equal to the time of falling through AB; but BC is described with the velocity acquired by falling through AB: and therefore by number 4 of perpendicular descents, BC is double of AB, and EV is double of BE; therefore,  $EV^2 = 4 BE^2 = 4 BE \times AB = BE \times 4 AB$ , and  $4 AB$  is the parameter or latus rectum of the parabola BVG, and, AB being one fourth of the parameter, AD is the directrix.

4. The times of describing the different arches BV, VG, of the parabola are as the portions BC, BH, of the tangent, or as the portions AD, Ad, of the directrix, intercepted by the same vertical lines AB, CV, HG; for the times of describing BV, BVG, are the same with those of describing the corresponding parts BC, BH, of the tangent, and are proportional to these parts, because the motion along BH is uniform; and BC, BH, are proportional to AD, Ad. Therefore the motion estimated horizontally is uniform.

5. The velocity in any point G of the curve is the same with that which a heavy body would acquire by falling from the directrix along dG. Draw the tangent GT, cutting the vertical AB in T; take the points a, f, equidistant from A and a, and extremely near them, and draw the vertices a b, f g; let the points a, f, continually approach A and d, and ultimately coincide with them. B b will therefore ultimately be to g G in the ratio of the velocity at B to the velocity at G (for the portions of the tangent ultimately coincide with the portions of the curve, and are described in equal times); but B b is to G g as BH to TG: therefore the velocity at B is to that at G as BH to TG. But, by the properties of the parabola,  $BH^2$  is to  $TG^2$  as AB to dG; and AB is to dG as the square of the velocity acquired by falling through AB to the square of the velocity acquired by falling through dG; and the velocity in BH, or in the point B of the parabola, is the velocity acquired by falling along AB; therefore the velocity in TG, or in the point G of the parabola, is the velocity acquired by falling along dG.

The preceding propositions contain all the theory of the motion of projectiles in vacuo, or independent on the resistance of the air; and being a very easy and neat exhibition of mathematical philosophy, and connected with a very interesting practice, they have been much commented on, and have furnished matter for many splendid volumes. But the resistance of the air occasions such a prodigious diminution of motion in the great velocities of military projectiles, that this parabolic theory, as it is called, is of little practical use. A musket ball, discharged with the ordinary allotment of powder, issues from the piece with the velocity of 1670 feet per second: this velocity would be acquired by falling from the height of eight miles. If the piece be elevated to an angle of  $45^\circ$ , the parabola should be of such extent that it would reach six-tens miles on the horizontal plain; whereas it does not reach much above half a mile. Similar deficiencies are observed in the ranges of cannon shot. It is unnecessary, therefore, to enlarge upon this theory.

Facts prove, beyond all doubt, how deficient the parabolic theory is, and how unfit for directing the practice of the artilleryist. A very simple consideration is sufficient for rendering this obvious to the most un instructed. The resistance of the air to a very light body may greatly exceed its weight. Any one will feel this in trying to move a fan very rapidly through the air; therefore this resistance would occasion a greater deviation from uniform motion than gravity would in that body. Its path, therefore, through the

air may differ more from a parabola than a parabola itself deviates from the straight line. For these reasons, we affirm that the voluminous treatises which have been published on this subject are nothing but ingenious amusements for young mathematicians. All that seems possible to do for the practical artillerist is, to multiply judicious experiments on real pieces of ordnance, with the charges that are used in actual service, and to furnish him with tables calculated from such experiments.

SECT. III.—OF THE CAUSES OF THE DEFICIENCY OF THE PARABOLIC THEORY.

It is, however, the business of the philosopher to enquire into the causes of such a prodigious deviation from a well founded theory; and, having discovered them, to ascertain precisely the deviations they occasion. Thus we shall obtain another theory, either in the form of the parabolic theory corrected, or as a subject of independent discussion.

The motion of projectiles being performed in the atmosphere, the air is displaced, or put in motion. Whatever motion it acquires must be taken from the bullet. The motion communicated to the air must be in the proportion of the quantity of air put in motion, and of the velocity communicated to it. If, therefore, the displaced air be always similarly displaced, whatever be the velocity of the bullet, the motion communicated to it, and lost by the bullet, must be proportional to the square of the velocity of the bullet and to the density of the air jointly. Therefore the diminution of its motion must be greater when the motion itself is greater; and in the very great velocity of shot and shells it must be prodigious. From Mr. Robins's experiments it is plain that a globe of four inches and a half in diameter, moving with the velocity of twenty-five feet in a second, sustained a resistance of 115 grains, nearly three-quarters of an ounce. Suppose this ball to move 800 feet in a second, that is, thirty-two times faster, its resistance would be  $32 \times 32$  times three-quarters of an ounce, or 768 ounces, or forty-eight pounds. This is four times the weight of a ball of cast iron of this diameter; and, if the initial velocity had been 1600 feet per second, the resistance would be at least sixteen times the weight of the ball. It is indeed much greater.

No great a resistance, operating constantly and uniformly on the ball, must take away four times as much from its velocity as its gravity would do in the same time. In one second gravity would reduce the velocity 800 to 768, if the ball were projected straight upwards. This resistance of the air would therefore reduce it in one second to 672, if it operated uniformly; but as the velocity diminishes continually by the resistance, and the resistance diminishes along with the velocity, the real diminution will be somewhat less than 128 feet. We shall, however, find, that in one second its velocity will be reduced from 800 to 687. From this instance it is clear that the resistance of the air must occasion great deviation from parabolic motion.

To judge accurately of its effect, we must consider it as a retarding force, as we consider

gravity. The weight  $W$  of a body is the aggregate of the action of the force of gravity  $g$  on each particle of the body. Suppose the number of equal particles, or the quantity of matter, of a body, to be  $M$ , then  $W$  is equivalent to  $gM$ . In like manner, the resistance  $R$ , observed in any experiment, is the aggregate of the action of a retarding force  $R'$  on each particle, and is equivalent to  $R'M$ : and as  $g$  is equal to  $\frac{W}{M}$ , so  $R'$  is equal to  $\frac{R}{M}$ . Let us keep this distinction in

view, by adding the differential mark ' to the letter  $R$  or  $r$ , which expresses the aggregate resistance.

If we thus consider resistance as a retarding force, we can compare it with any other such force by means of the retardation which it produces in similar circumstances. We would compare it with gravity by comparing the diminution of velocity which its uniform action produces in a given time with the diminution produced in the same time by gravity. But we have no opportunity of doing this directly; for, when the resistance of the air diminishes the velocity of a body, it diminishes it gradually which occasions a gradual diminution of its own intensity. This is not the case with gravity, which has the same action on a body in motion or at rest. We cannot, therefore, observe the uniform action of the resistance of the air as a retarding force. We must make the comparison in some other way. We can state them both as dead pressures. A ball may be fitted to the rod of a spring steelyard, and exposed to the impulse of the wind. This will compress the steelyard to the mark 3, for instance. Perhaps the weight of this ball will compress it to the mark 6. Half this weight would compress it to 3. We reckon this equal to the pressure of the air, because they balance the same elasticity of the spring. In this way we can estimate the resistance by weights whose pressures are equal to its pressure; and we can thus compare it with other resistances, weights, or any other pressures. In fact, we are measuring them by all the elasticity of the spring. This elasticity in its different positions is supposed to have the proportions of the weights which keep it in these positions. Thus we reason from the nature of gravity, no longer considered as a dead pressure, but as a retarding force; and we apply our conclusions to resistances which exhibit the same pressures, but which we cannot make to act uniformly. This sense of the words must be remembered whenever we speak of resistances in pounds and ounces.

The most convenient and direct way of stating the comparison between the resistance of the air and the accelerating force of gravity, is to take a case in which we know that they are equal. Since the resistance is here assumed as proportional to the square of the velocity, it is evident that the velocity may be so increased that the resistance shall equal or exceed the weight of the body. If a body be already moving downwards with this velocity, it cannot accelerate; because the accelerating force of gravity is balanced by an equal retarding force of resistance. It follows



from this remark that this velocity is the greatest that a body can acquire by the force of gravity only. Nay, we shall see that it never can completely attain it; because, as it approaches to this velocity, the remaining accelerating force decreases faster than the velocity increases. It may therefore be called the limiting or terminal velocity by gravity.

Let  $a$  be the height through which a heavy body must fall, in vacuo, to acquire its terminal velocity in air. If projected directly upwards with this velocity, it will rise again to this height, and the height is half the space which it would describe uniformly, with this velocity, in the time of its ascent. Therefore, the resistance to this velocity being equal to the weight of the body, it would extinguish this velocity, by its uniform action, in the same time, and after the same distance, that gravity would. Now let  $g$  be the velocity which gravity generates or extinguishes during an unit of time, and let  $u$  be the terminal velocity of any particular body. The theorems

for perpendicular ascents give us  $g = \frac{u^2}{2a}$ ,  $u$  and  $a$  being both numbers representing units of space; therefore, in the present case, we have  $r' = \frac{u^2}{2a}$ . For the whole resistance  $r$ , or  $r' M$ ,

is supposed equal to the weight, or to  $g M$ ; and therefore  $r'$  is equal to  $g$ ,  $= \frac{u^2}{2a}$  and  $2a = \frac{u^2}{g}$ . There is a consideration which ought to

have place here. A body descends in air, not by the whole of its weight, but by the excess of its weight above that of the air which it displaces. It descends by its specific gravity only as a stone does in water. Suppose a body thirty-two times heavier than air, it will be buoyed up by a force equal to  $\frac{1}{32}$  of its weight; and, instead of acquiring the velocity of thirty-two feet in a second, it will only acquire a velocity of thirty-one, even though it sustained no resistance from the inertia of the air. Let  $p$  be the weight of the body, and  $\pi$  that of an equal bulk of air: the accelerative force of relative gravity on each particle will be

$g \times 1 - \frac{\pi}{p}$ ; and this relative accelerating force might be distinguished by another symbol  $\gamma$ . But in all cases in which we have any interest, and particularly in military projectiles,  $\frac{\pi}{p}$  is so

small a quantity that it would be pedantic affectation to attend to it. It is much more than compensated when we make  $g = 32$  feet, instead of  $32\frac{1}{11}$ , which it should be.

Let  $e$  be the time of this ascent in opposition to gravity. The same theorems give us  $e u = 2a$ ; and, since the resistance competent to this terminal velocity is equal to gravity,  $e$  will also be the time in which it would be extinguished by the uniform action of the resistance; for which reason we may call it the extinguishing time for this velocity. Let  $R$  and  $E$  mark the resistance and extinguishing time for the same body moving with the velocity 1.

As the resistances are as the squares of the ve-

locities, and the resistance to the velocity  $u$  is  $\frac{u^2}{2a}$ ,  $R$  will be  $= \frac{1}{2a}$ . Moreover, the times in which the same velocity will be extinguished by different forces, acting uniformly, are inversely as the forces, and gravity would extinguish the velocity 1 in the time  $\frac{1}{g}$  (in these measures)

to  $\frac{1}{u^2} = \frac{2a}{u^2}$ . Therefore we have the following

proportion,  $\frac{1}{2a} (= R) : \frac{u^2}{2a} (= g) = \frac{2a}{u^2} : 2a$ ,

and  $2a$  is equal to  $E$ , the time in which the velocity 1 will be extinguished by the uniform action of the resistance competent to this velocity. The velocity 1 would in this case be extinguished after a motion uniformly retarded, in which the space described is one-half of what would be uniformly described during the same time with the constant velocity 1. Therefore the space thus described by a motion which begins with the velocity 1, and is uniformly retarded by the resistance competent to this velocity, is equal to the height through which this body must fall in vacuo in order to acquire its terminal velocity in air.

The following description may render all these circumstances more easily conceived by some readers. The terminal velocity is that where the resistance of the air balances and is equal to the weight of the body. The resistance of the air to any particular body is as the square of the velocity; therefore let  $R$  be the whole resistance to the body moving with the velocity 1, and  $r$  the resistance to its motion with the terminal velocity  $u$ ; we must have  $r = R \times u^2$ , and this must be  $= W$ , the weight. Therefore, to obtain the terminal velocity, divide the weight by the resistance to the velocity 1, and the quotient is the square of the terminal velocity, or  $\frac{W}{R} = u^2$ : and

this is a very expeditious method of determining it, if  $R$  be previously known. Then the common theorems give  $a$ , the fall necessary for producing this velocity in vacuo  $= \frac{u^2}{2g}$ , and the time

of the fall  $= \frac{u}{g} = e$ , and  $e u = 2a$ , = the

space uniformly described with the velocity  $u$  during the time of the fall, or its equal, the time of the extinction by the uniform action of the resistance  $r$ ; and, since  $r$  extinguishes it in the time  $e$ ,  $R$  which is  $u^2$  times smaller will extinguish it in the time  $u^2 e$ , and  $R$  will extinguish the velocity 1, which is  $u$  times less than  $u$ , in the time  $u e$ , that is, in the time  $2a$ ; and the body moving uniformly during the time  $2a = E$ , with the velocity 1, will describe the space  $2a$ ; and if the body begin to move with the velocity 1, and be uniformly opposed by the resistance  $R$ , it will be brought to rest when it has described the space  $a$ ; and the space in which the resistance to the velocity 1 will extinguish that velocity by its uniform action is equal to the height through which that body must fall in vacuo in order to acquire its terminal velocity in air. And thus every thing is regulated by the

time  $E$  in which the velocity  $1$  is extinguished by the uniform action of the corresponding resistance, or by  $2a$ , which is the space uniformly described during this time, with the velocity  $1$ . And  $E$  and  $2a$  must be expressed by the same number. It is a number of units, of time, or of length.

Thus, having ascertained these leading circumstances for a unit of velocity, weight, and bulk, we proceed to deduce the similar circumstances for any other magnitude; and, to avoid unnecessary complications, we shall always suppose the bodies to be spheres, differing only in diameter and density. First, then, let the velocity be increased in the ratio of  $1$  to  $v$ .

The resistance will now be  $\frac{v^2}{2a} = r$

The extinguishing time will be  $\frac{E}{v} = e, = \frac{2a}{v}$  and  $ev = 2a$ ; so that the rule is general, that the space along which any velocity will be extinguished by the uniform action of the corresponding resistance is equal to the height necessary for communicating the terminal velocity to that body by gravity. For  $ev$  is twice the space through which the body moves while the velocity  $v$  is extinguished by the uniform resistance

2dly, Let the diameter increase in the proportion of  $1$  to  $d$ . The aggregate of the resistance changes in the proportion of the surface similarly resisted, that is, in the proportion of  $1$  to  $d^2$ . But the quantity of matter, or number of particles among which this resistance is to be distributed, changes in the proportion of  $1$  to  $d^3$ . Therefore the retarding power of the resistance changes in the proportion of  $1$  to  $\frac{1}{d}$ . When the diameter

was  $1$  the resistance to a velocity  $1$  was  $\frac{1}{2a}$ . It

must now be  $\frac{1}{2ad}$ . The time in which this diminished resistance will extinguish the velocity  $1$  must increase in the proportion of the diminution of force, and must now be  $Ed$ , or  $2ad$ , and the space uniformly described during this time with the initial velocity  $1$  must be  $2ad$ ; and this must still be twice the height necessary for communicating the terminal velocity  $w$  to this body. We must still have  $g = \frac{w^2}{2ad}$ ; and

therefore  $w^2 = 2gad$ , and  $w = \sqrt{2gad}$ ,  $= \sqrt{2ga} \sqrt{d}$ . But  $u = \sqrt{2ga}$ . Therefore the terminal velocity  $w$  for this body is  $= u \sqrt{d}$ ; and the height necessary for communicating it is  $ed$ . Therefore the terminal velocity varies in the subduplicate ratio of the diameter of the ball, and the fall necessary for producing it varies in the simple ratio of the diameter. The extinguishing time for the velocity  $v$  must now be  $\frac{Ed}{v}$ .

3dly, If the density of the ball be increased in the proportion of  $1$  to  $m$ , the number of particles among which the resistance is to be distributed is increased in the same proportion, and therefore the retarding force of the resistance is equally diminished; and, if the density of the air is in-

creased in the proportion of  $1$  to  $n$ , the retarding force of the resistance increases in the same proportion: hence we easily deduce these general expressions.

$$\text{The terminal velocity} = u \sqrt{\frac{d^m}{n}} = \sqrt{\frac{2gad^m}{n}}$$

$$\text{The producing fall in vacuo} = ad \frac{m}{n}$$

$$\text{The retarding power of resistance to any velocity} = r' = \frac{v^2}{2ad \frac{m}{n}}$$

$$\text{The extinguishing time for any velocity } v = \frac{Edm}{vn}$$

Thus we see that the chief circumstances are regulated by the terminal velocity, or are conveniently referred to it.

To communicate distinct ideas, and render the deductions from these premises perspicuous, it will be proper to assume some convenient units, by which all these qualities may be measured; and, as this subject is chiefly interesting in the case of military projectiles, we shall adapt our units to this purpose. Therefore let a second be the unit of time, a foot the unit of space and velocity, an inch the unit of diameter of a ball or shell, and a pound avoirdupois the unit of pressure, whether of weight or of resistance: therefore  $g$  is thirty-two feet. The great difficulty is to procure an absolute measure of  $r$ , or  $u$ , or  $a$ ; any one of these will determine the others.

Sir Isaac Newton attempted to determine  $r$  by theory, and employed a great part of the second book of the Principia in demonstrating, that the resistance to a sphere moving with any velocity is to the force which would generate or destroy its whole motion in the time that it would uniformly move over eight-thirds of its diameter with this velocity as the density of the air is to the density of the sphere. This is equivalent to demonstrating, that the resistance of the air to a sphere, moving through it with a velocity, is equal to half the weight of a column of air having a great circle of the sphere for its base, and for its altitude the height from which a body must fall in vacuo to acquire this velocity. This appears from Newton's demonstration; for, let the specific gravity of the air be to that of the ball as  $1$  to  $m$ ; then, because the times in which the same velocity will be extinguished by the uniform action of different forces are inversely as the forces, the resistance to this velocity would extinguish it in the time of describing eight-thirds  $md$ ,  $d$  being the diameter of the ball. Now  $1$  is to  $m$  as the weight of the displaced air to the weight of the ball, or as two-thirds of the diameter of the ball to the length of a column of air of equal weight. Call this length  $a$ ;  $a$  is therefore equal to two-thirds  $md$ . Suppose the ball to fall from the height  $a$  in the time  $t$ , and acquire the velocity  $u$ . If it moved uniformly with this velocity, during this time, it would describe a space  $= 2a$ , or four-thirds  $md$ . Now its weight would extinguish this velocity, or destroy



L

this motion, in the same time, that is, in the time of describing four-thirds  $md$ ; but the resistance of the air would do this in the time of describing eight-thirds  $md$ ; that is, in twice the time. The resistance therefore is equal to half the weight of the ball, or to half the weight of the column of air whose height is the height producing the velocity. But the resistance to different velocities are as the squares of the velocities; and therefore as their producing heights, and, in general, the resistance of the air to a sphere moving with any velocity, is equal to the half weight of a column of air of equal section, and whose altitude is the height producing the velocity.

The result of this investigation has been acquiesced in by all Sir Isaac Newton's commentators. Many faults have indeed been found with his reasoning, and even with his principles; and it must be acknowledged that although this investigation is by far the most ingenious of any in the Principia, and sets his acuteness and address in the most conspicuous light, his reasoning is liable to serious objections, which his most ingenious commentators have not completely removed. Yet the conclusion has been acquiesced in, but as if derived from other principles, or by more logical reasoning. The reasonings or assumptions, however, of these mathematicians are no better than Newton's; and all the causes of deviation from the duplicate ratio of the velocities, and the causes of increased resistance, which the latter authors have valued themselves for discovering and introducing into their investigations, were actually pointed out by Sir Isaac Newton, but purposely omitted by him to facilitate the discussion in *re difficillima* (See Schol. prop. 37. b. 2).

The weight of a cubic foot of water is  $62\frac{1}{2}$  lbs. and the medium density of the air is  $\frac{1}{840}$  of water; therefore let  $a$  be the height producing the velocity (in feet), and  $d$  the diameter of the ball (in inches), and  $\pi$  the periphery of a circle whose diameter is 1; the resistance of the air will be =  $62\frac{1}{2} \times \frac{\pi}{4} \times \frac{1}{144} \times \frac{a}{2} \times d^2 = \frac{a d^2}{4928\frac{1}{2}}$  pounds, very nearly, =  $\frac{v^2 d^2}{4928\frac{1}{2} \times 64} d^2 = \frac{v^2 d^2}{315417}$  pounds.

*Example.*—A ball of cast iron weighing twelve pounds is four inches and a half in diameter. Suppose this ball to move at the rate of  $25\frac{1}{10}$  feet in a second. The height which will produce this velocity in a falling body is  $9\frac{1}{2}$  feet. The area of its great circle is 0.11044 feet, or  $\frac{1104}{100000}$  of one foot. Suppose water to be 840 times heavier than air, the weight of the air incumbent on this great circle, and  $9\frac{1}{2}$  feet high, is 0.081151 lbs. half of this is 0.0405755 or  $\frac{405755}{10000000}$ , or nearly  $\frac{1}{250000}$  of a pound. This should be the resistance of the air to this motion of the ball.

It is proper, in all matters of physical discussion, to confront every theoretical conclusion with experiment. This is particularly necessary in the present instance, because the theory on which this proposition is founded is extremely uncertain. Newton speaks of it with the most cautious diffidence, and secures the justness of the conclusions by the conditions which he as-

sumes in his investigation. He describes with the greatest precision the state of the fluid in which the body must move, so as that the demonstrations may be strict, and leaves it to others to pronounce whether this is the real constitution of our atmosphere. It must be granted that it is not; and that many other suppositions have been introduced by his commentators and followers to suit his investigation (for little or nothing has been added to it) to the circumstances of the case.

Sir Isaac Newton himself, therefore, attempted to compare his proportions with experiment. Some were made by dropping balls from the dome of St. Paul's cathedral; and all these showed as great a coincidence with his theory as they did with each other: but the irregularities were too great to allow him to say with precision what was the resistance. It appeared to follow the proportion of the squares of the velocities with sufficient exactness; and, though he could not say that the resistance was equal to the weight of the column of air having the height necessary for communicating the velocity, it was always equal to a determinate part of it; and might be stated =  $na$ ,  $n$  being a number to be fixed by numerous experiments. One great source of uncertainty in his experiments seems to have escaped his observation: the air in that dome is almost always in a state of motion. In summer there is a very sensible current of air downwards, and frequently in winter it is upwards: and this current bears a very great proportion to the velocity of the descents. Sir Isaac takes no notice of this. He made another set of experiments with pendulums; and pointed out some very curious and unexpected circumstances of their motions in a resisting medium. There is hardly any part of his noble work in which his address, his patience, and his astonishing penetration, appear in greater lustre. It requires the utmost intenseness of thought to follow him in these disquisitions. Their results were much more uniform, and confirmed his general theory; and it has been acquiesced in by the first mathematicians of Europe.

But the deductions from this theory were so inconsistent with the observed motions of military projectiles, when the velocities are prodigious, that no application could be made which could be of any service for determining the path and motion of cannon shot and bombs; and although John Bernoulli gave, in 1718, a most elegant determination of the trajectory and motion of a body projected in a fluid which resists in the duplicate ratio of the velocities (a problem which even Newton did not attempt), it has remained a dead letter. Mr. Benjamin Robins was the first who suspected the true cause of the imperfection of the usually received theories; and in 1737 he published a small tract, in which he showed clearly that even the Newtonian theory of resistance must cause a cannon ball discharged with a full allotment of powder, to deviate farther from the parabola, in which it would move in vacuo, than the parabola deviates from a straight line. But he farther asserted from good reasoning, that in such great velocities the resistance must be much greater than the

theory assigns; because, besides the resistance arising from the inertia of the air which is put in motion by the ball, there must be a resistance arising from a condensation of the air on the anterior surface of the ball, and a rarefaction behind it: and there must be a third resistance, arising from the statical pressure of the air on its anterior part, when the motion is so swift that there is a vacuum behind. Even these causes of disagreement with the theory had been foreseen and mentioned by Newton (see the Scholium to prop. 37, Book II. Princip.); but the subject seems to have been little attended to. Some authors, however, such as St. Remy, Antonini, and Le Blond, have given most valuable collections of experiments, ready for the use of the profound mathematician.

SECT. IV.—OBSERVATIONS BY MR. ROBINS, ON VELOCITY AND RESISTANCE.

Two or three years after the appearance of his first publication, Mr. Robins discovered that ingenious method of measuring the velocities of military projectiles which has handed down his name to posterity with great honor: and, having ascertained these velocities, he discovered the prodigious resistance of the air, by observing the diminution of velocity which it occasioned. This made him anxious to examine what was the real resistance to any velocity whatever, in order to ascertain what was the law of its variation; and he was equally fortunate in this attempt likewise. From his Mathematical Works, vol. i. p. 205. it appears that a sphere of four inches and a half in diameter, moving at the rate of twenty-five feet one-fifth in a second, sustained a resistance of 0.04914 lb. or  $\frac{1}{25}$  of a pound. This is a greater resistance than that of the Newtonian theory, which gave  $\frac{1887}{1000}$  in the proportion of 1000 to 1211, or very nearly in the proportion of five to six in small numbers. And we may adopt as a rule, in all moderate velocities, that the resistance to a sphere is equal to  $\frac{1}{25}$  of the weight of a column of air having the great circle of the sphere for its base, and for its altitude the height through which a heavy body must fall in vacuo to acquire the velocity of projection. The importance of this experiment is great, because the ball is precisely the size of a twelve pound shot of cast iron; and its accuracy may be depended on. There is but one source of error. The whirling motion must have occasioned some whirl in the air, which would continue till the ball again passed through the same point of its revolution. The resistance observed is therefore probably somewhat less than the true resistance to the velocity of twenty-five feet one-fifth, because it was exerted in a relative velocity which was less than this, and is, in fact, the resistance competent to this relative and smaller velocity. Accordingly, Mr. Smeaton places great confidence in the observations of Mr. Rouse of Leicester-shire, who measured the resistance by the effect of the wind on a plane properly exposed to it. He does not tell us how the velocity of the wind was ascertained; but our opinion of his penetration and experience leads us to believe that this point was well determined. The resistance observed by Mr. Rouse exceeds that

resulting from Mr. Robins's experiments nearly in the proportion of seven to ten. Chev. de Borda made experiments similar to those of Mr. Robins, and his results exceeded those of Robins in the proportion of five to six.

We must content ourselves, however, at present with the experimental measure mentioned above. To apply to our formulæ, therefore, we reduce this experiment, which was made on a ball of four inches and a half diameter, moving with the velocity of twenty-five feet and one-fifth per second, to what would be the resistance to a ball of one inch, having the velocity a foot.

This will give  $R = \frac{0.04919}{4.5^2 \times 25^2}$ , being diminished in the duplicate ratio of the diameter and velocity. This gives  $R = 0.00000381973$  pound, or  $\frac{3.81973}{1000000}$  of a pound. The logarithm is,

4.58204. The resistance here determined is the same whatever substance the ball be of; but the retardation occasioned by it will depend on the proportion of the resistance to the vis insita of the ball; that is, to its quantity of motion. This in similar velocities and diameters is as the density of the ball. The balls used in military service are of cast iron, or of lead, whose specific gravities are 7.207 and 11.37 nearly, water being 1. There is considerable variety in cast iron, and this density is about the medium. These data will give us,

	For Iron.	For Lead.
W, or weight of a ball one inch in diameter . . . lbs.	0.13648	0.21533
Log. of W . . . . .	9.13509	9.33310
E' . . . . .	1116',6	1761',6
Log. of E . . . . .	3.04790	3.24591
u, or terminal velocity . . .	189,03	237.43
Log. u . . . . .	2.27653	2.37553
u, or producing height . . .	558,3	880,8

These numbers are of frequent use in all questions on this subject. Mr. Robins gives an expeditious rule for readily finding *a*, which he calls *F*, by which it is made 900 feet for a cast-iron ball of an inch diameter. But no theory of resistance which he professes to use will make this height necessary for producing the terminal velocity. His *F*, therefore, is an empirical quantity, analogous indeed to the producing height, but accommodated to his theory of the trajectory of cannon-shot, which he promised to publish, but did not live to execute. We need not be very anxious about this; for all our quantities change in the same proportion with *R*, and need only a correction by a multiplier or divisor, when *R* shall be accurately established.

The use of these formulæ may be illustrated by an example or two.

Ex. 1. To find the resistance to a twenty-four pound ball moving with the velocity of 1670 feet in a second, which is nearly the velocity communicated by sixteen pounds of powder. The diameter is  $\frac{2}{5}$ 03 inches.

Log. R . . . . .	+ 4.58204
Log. $d^3$ . . . . .	+ 1.49674
Log. 1670 <sup>2</sup> . . . . .	+ 6.44548
<hr/>	
Log. 3344 lbs. = <i>r</i> . . . . .	2.52426

But it is found, by unequivocal experiments on the retardation of such a motion, that it is 504 lbs. This is owing to the above causes, the additional resistance to great velocities, arising from the condensation of the air, and from its pressure into the vacuum left by the ball.

Ex. 2. Required the terminal velocity of this ball?

Log. R	. . . . .	+ 4.58204
Log. $d^2$	. . . . .	+ 1.49674
<hr/>		
Log. resist. to veloc. 1	. . . . .	6.07878 = $a$
Log. W	. . . . .	1.38021 = $b$
Diff. of $a$ and $b$ , = $\log. u^2$	. . . . .	5.30143
Log. 4474	= $u$	2.65071

We proceed to consider these motions through their whole course: and we shall first consider them as affected by the resistance only; then we shall consider the perpendicular ascents and descents of heavy bodies through the air; and, lastly, their motion in a curvilinear trajectory, when projected obliquely. This must be done by the help of the abstruser parts of fluxionary mathematics. To make it more perspicuous, we shall consider the simply resisted rectilineal mo-

tions geometrically, in the manner of Sir Isaac Newton. As we advance, we shall quit this track, and prosecute it algebraically, having by this time acquired distinct ideas of the algebraic quantities.

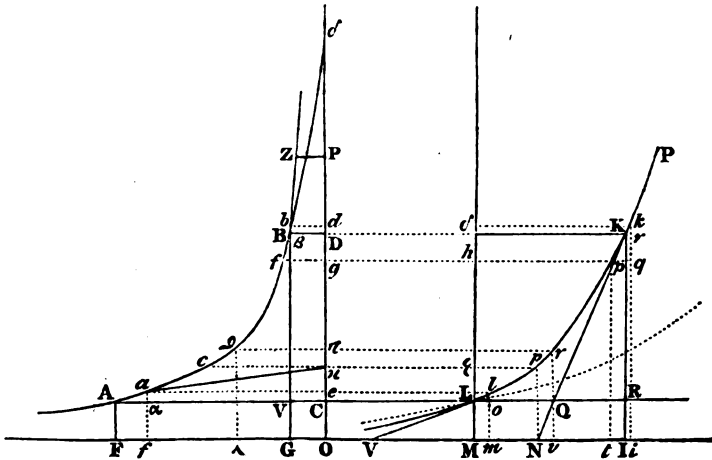
We must remember the fundamental theorems of varied motions.

1. The momentary variation of the velocity is proportional to the force and the moment of time jointly, and may therefore be represented by  $\pm \dot{v} = f t$ , where  $v$  is the momentary increment or decrement of the velocity  $v$ ,  $f$  the accelerating or retarding force, and  $t$  the moment or increment of the time  $t$ .

2. The momentary variation of the square of the velocity is as the force, and as the increment or decrement of the space jointly; and may be represented by  $\pm v \dot{v} = f s$ . The first proposition is familiarly known. The second is the 39th of Newton's Principia, B. I. It is demonstrated in the article OPTICS, and is the most extensively useful proposition in mechanics.

Having premised these things, let the straight line AC (fig. 2) represent the initial velocity V, and let CO, perpendicular to AC, be the time

Fig. 2.



in which this velocity would be extinguished by the uniform action of the resistance. Draw through the point A an equilateral hyperbola  $A e B$  having OF, OCD, for its asymptotes; then let the time of the resisted motion be represented by the line CB, C being the first instant of the motion. If there be drawn perpendicular ordinates  $\kappa e, fg, DB$ , &c., to the hyperbola, they will be proportional to the velocities of the body at the instant;  $\kappa, g, D$ , &c., and the hyperbolic areas  $A C \kappa e, A C, fg, A C D B$ , &c., will be proportional to the spaces described during the times  $C \kappa, C g, C B$ , &c. For suppose the time divided into an indefinite number of small and equal moments,  $C c, D d$ , &c., draw the ordinates  $a c, b d$ , and the perpendiculars  $b \beta, a \alpha$ . Then, by the nature of the hyperbola,  $A C : a c = O c : O C$ , and  $A C - a c : a c = O c - O C : O C$ , that is,  $A \alpha : a c = C c : O C$ , and  $A \alpha : C c = a c : O C = A C : a c : A C : O C$ ; in like manner,  $B \beta : D d = B D : b d : B D : O D$ . Now  $D d = C c$ , because the moments of time were

taken equal, and the rectangles  $A C \cdot C O, B D \cdot D O$ , are equal by the nature of the hyperbola; therefore  $A \alpha : B \beta = A C : a c : B D : b d$ ; but as the points  $c, d$ , continually approach, and ultimately coincide with C, D, the ultimate ratio of  $A C \cdot a c$  to  $B D \cdot b d$  is that of  $A C^2$  to  $B D^2$ ; therefore the momentary decrements of AC and BD are as  $A C^2$  and  $B D^2$ . Now, because the resistance is measured by the momentary diminution of velocity, these diminutions are as the squares of the velocities; therefore the ordinates of the hyperbola and the velocities diminish by the same law; and the initial velocity was represented by AC; therefore the velocities at all the other instants  $\kappa, g, D$ , are properly represented by the corresponding ordinates. Hence,

1. As the abscissa of the hyperbola are as the times, and the ordinates are as the velocities, the areas will be as the spaces described, and  $A C \kappa e$  is to  $A c g f$  as the space described in the time  $C \kappa$  to the space described in the time  $C g$  (first theorem on varied motions).

2. The rectangle ACOF is to the area ACDB as the space formerly expressed by  $2a$ , or  $E$  to the space described in the resisting medium during the time  $CD$ ; for  $AC$  being the velocity  $V$ , and  $OC$  the extinguishing time  $e$ , this rectangle is  $= eV$ , or  $E$ , or  $2a$ , of our former disquisitions; and because all the rectangles such as ACOF, BDOG, &c., are equal, this corresponds with our former observation, that the space uniformly described with any velocity during the time in which it would be uniformly extinguished by the corresponding resistance is a constant quantity, viz. that in which we always had  $v = E$ , or  $2a$ .

3. Draw the tangent  $A\kappa$ ; then, by the hyperbola  $C\kappa = CO$ : now  $C\kappa$  is the time in which the resistance to the velocity  $AC$  would extinguish it; for the tangent coinciding with the elemental arc  $Aa$  of the curve, the first impulse of the uniform action of the resistance is the same with its first impulse of its varied action. By this the velocity  $AC$  is reduced to  $ac$ . If this operated uniformly, like gravity, the velocities would diminish uniformly, and the space described would be represented by the triangle  $AC\kappa$ . This triangle, therefore, represents the height through which a heavy body must fall in vacuo, in order to acquire the terminal velocity.

4. The motion of a body resisted in the duplicate ratio of the velocity will continue without end, and a space will be described which is greater than any assignable space, and the velocity will grow less than any that can be assigned; for the hyperbola approaches continually to the asymptote, but never coincides with it. There is no velocity  $BD$  so small, but a smaller  $ZP$  will be found beyond it; and the hyperbolic space may be continued till it exceeds any surface that can be assigned.

5. The initial velocity  $AC$  is to the final velocity  $BD$  as the sum of the extinguishing time and the time of the retarded motion is to the extinguishing time alone; for  $AC : BD = OD$  (or  $OC \times CD$ ) :  $OC$ : or  $V : v = e : e \times t$ .

6. The extinguishing time is to the time of the retarded motion as the final velocity is to the velocity lost during the retarded motion: for the rectangles AFOC, BDOG, are equal; and therefore AVGF and BVCD are equal and  $VC : VA = VG : VB$ ; therefore  $t = \frac{eV-v}{v}$ ,

$$\text{and } e = t \frac{v}{V-v}.$$

7. Any velocity is reduced in the proportion of  $m$  to  $n$  in the time  $e \frac{m-n}{n}$ . For, let  $AC : BD = m : n$ ; then  $DO : CO = m : n$ , and  $DC : CO = m-n : n$ , and  $DC = \frac{m-n}{n} CO$ , or  $t = e \frac{m-n}{n}$ . Therefore any velocity is reduced to one-half in the time in which the initial resistance would have extinguished it by its uniform action.

The chief circumstances of this motion may thus be determined by the hyperbola, the ordinates and abscissæ exhibiting the relations of the

times and velocities, and the areas exhibiting the relations of both to the spaces described. But we may render the conception of these circumstances much more easy and simple, by expressing them all by lines, instead of this combination of lines and surfaces. We shall accomplish this purpose by constructing another curve LKP, having the line  $ML\delta$ , parallel to  $OD$  for its abscissa, and of such a nature that if the ordinates to the hyperbola  $ACe\kappa, fg, BD$ , &c. be produced till they cut this curve in  $L, p, n, K$ , &c., and the abscissa in  $L, e, h, \delta$ , &c., the ordinates  $e, p, h, n, \delta, K$ , &c., may be proportional to the hyperbolic areas  $eAC\kappa, fAcg, \delta ACk$ . Let us examine what kind of curve this will be. Make  $OC : O\kappa = O\kappa : Og$ ; then (Hamilton's Conics, IV. 14. Cor.) the areas  $AC\kappa e, e\kappa gf$  are equal: therefore drawing  $ps, nt$ , perpendicular to  $OM$ , we shall have (by the assumed nature of the curve  $LpK$ ),  $Ms = st$ ; and if the abscissa  $OD$  be divided into any number of small parts in geometrical progression, (reckoning the commencement of them all from  $O$ ), the axis  $Vi$  of this curve will be divided by its ordinates into the same number of equal parts; and this curve will have its ordinates  $LM, ps, nt$ , &c., in geometrical progression, and its abscissæ in geometrical progression. Also, let  $KN, MV$ , touch the curve in  $K$  and  $L$ , and let  $OC$  be supposed to be to  $OC$ , as  $OD$  to  $Od$ , and therefore  $Cc$  to  $Dd$  as  $OC$  to  $OD$ ; and let these lines  $Cc, Dd$ , be indefinitely small; then (by the nature of the curve)  $Lo$  is equal to  $Kr$ ; for the areas  $aACc, bBDd$  are in this case equal. Also  $lo$  is to  $kr$ , as  $LM$  to  $KI$ , because  $cC : dD = CO : DO$ :

$$\begin{aligned} \text{Therefore } IN : IK &= rK : r\kappa \\ IK : ML &= r\kappa : ol \\ ML : MV &= ol : oL \\ \text{and } IN : MN &= rK : oL. \end{aligned}$$

That is the subtangent  $IN$ , or  $MV$ , is of the same magnitude, or is a constant quantity in every part of the curve.

Lastly, the subtangent  $IN$ , corresponding to the point  $K$  of the curve, is to the ordinate  $K\delta$  as the rectangle  $BDOG$  or  $ACOF$  to the parabolic area  $BDCa$ . For let  $fghn$  be an ordinate very near to  $BD\delta K$ ; and let  $an$  cut the curve in  $n$ , and the ordinate  $KI$  in  $g$ ; then we have

$$\begin{aligned} Kq : qn &= KI : IN, \text{ or} \\ Dg : qn &= DO : IN; \\ \text{but } BD : AC &= CO : DO; \end{aligned}$$

therefore  $BD \cdot Dg : AC \cdot qn = CO : IN$ : Therefore the sum of all the rectangles  $BD \cdot Dg$  is to the sum of all the rectangles  $AC \cdot qn$ , as  $CO$  to  $IN$ ; but the sum of the rectangles  $BD \cdot Dg$  is the space  $ACDB$ ; and, because  $AC$  is given, the sum of the rectangles  $AC \cdot qn$  is the rectangle of  $AC$ , and the sum of all the lines  $qn$ ; that is, the rectangle of  $AC$  and  $RL$ ; therefore the space  $ACDB : AC \cdot RL = CO : IN$ , and  $ACDB \times IN = AC \cdot CO \cdot RL$ ; and therefore  $IN : RL = AC \cdot CO : ACDB$ .

Hence it follows that  $QL$  expresses the area  $BVA$ , and, in general, that the part of the line parallel to  $OM$ , which lies between the tangent  $KN$  and the curve  $LpK$ , expresses the corresponding area of the hyperbola which lies with-

out the rectangle BDOG. And now, by the help of this curve, we have an easy way of conceiving and computing the motion of a body through the air. For the subtangent of our curve now presents twice the height through which the ball must fall in vacuo, in order to acquire the terminal velocity; and therefore serves for a scale on which to measure all the other representatives of the motion.

It remains to make another observation on the curve LpK, which will save us all the trouble of geographical operations, and reduce the whole to a very simple arithmetical computation. In constructing this curve we were limited to no particular length of the line LR, which represented the space ACDB; and all that we had to take care of was, that when OC, O $\pi$ , Og, were taken in geometrical progression, Ms, Mt, should be in arithmetical progression. The abscissæ having ordinates equal to ps, nt, &c., might have been twice as long as is shown in the dotted curve which is drawn through L. All the lines which serve to measure the hyperbolic spaces would then have been doubled. But NI would also have been doubled, and our proportions would have still held good; because this sub-tangent is the scale of measurement of our figure, as E or 2a is the scale of measurement for the motions.

Since then we have tables of logarithms calculated for every number, we may make use of them instead of this geometrical figure, which still requires considerable trouble to suit it to every case. There are two sets of logarithmic tables in common use. One is called a table of hyperbolic or natural logarithms. It is suited to such a curve as is drawn in the figure, where the subtangent is equal to that ordinate rv which corresponds to the side  $\pi$ O of the square  $\pi\theta\lambda$ O inserted between the hyperbola and its asymptotes. This square is the unit of surface, by which the hyperbolic areas are expressed; its side is the unit of length, by which the lines belonging to the hyperbola are expressed;  $\pi v$  is 1, or the unit of numbers to which the logarithms are suited, and then IN is also 1. Now the square  $\theta\pi O\lambda$  being unity, the area BACD will be some number;  $\pi O$  being also unity, OD is some number: call it  $x$ . Then, by the nature of the hyperbola,  $OB : O\pi = \pi\theta : DB$ ; that is,  $x : 1 = 1 : \frac{1}{x}$ , so that DB is  $\frac{1}{x}$ . Now, calling D  $\delta x$  the area, B D  $\delta b$ , which is the fluxion (ultimately) of the hyperbolic area, is  $\frac{x}{x^2}$ .

Now in the curve LpK, MI has the same ratio to NI that BACD has to  $\theta\lambda O\pi$ . Therefore, if there be a scale of which NI is the unit, the number on this scale corresponding to MI has the same ratio to 1 which the number measuring BACD has to 1; and Ii, which corresponds to B D  $\delta b$ , is the fluxion (ultimately) of MI;

Therefore, if MI be called the logarithm of  $x, \frac{x}{x^2}$  is properly represented by the fluxion of MI. In short, the line MI is divided precisely as the line of numbers on a Gunter's scale, which is therefore a line of logarithms; and the numbers

called logarithms are just the lengths of the different parts of this line measured on a scale of equal parts.

Reasons of convenience have given rise to another set of logarithms: these are suited to a logistic curve whose subtangent is only  $\frac{u^2}{g}$  of the ordinate  $rv$ , which is equal to the side of the hyperbolic square, and which is assumed for the unit of number. We shall suit our applications of the preceding investigation to both these, and shall first use the common logarithms whose subtangent is 0.43429. The whole subject will be best illustrated by taking an example of the different questions which may be proposed: Recollect that the rectangle ACOF is  $= 2a$ , or  $\frac{u^2}{g}$ , or E, for a ball of cast iron one inch diameter, and, if it has the diameter  $d$ , it is  $\frac{u^2 d}{g}$ , or  $2ad$ , or E d.

I. It may be required to determine what will be the space described in a given time  $t$  by a ball setting out with a given velocity  $V$ , and what will be its velocity  $v$  at the end of that time. Here we have  $NI : MI = ACOF : BDC A$ ; now NI is the subtangent of the logistic curve; MI is the difference between the logarithms of OD and OC; that is, the difference between the logarithms of  $e + t$  and  $e$ ; ACOF is  $2ad$ , or  $\frac{u^2 d}{g}$ , or E d. Therefore by common logarithms 0.43429 :  $\log. e + t - \log. e = 2ad : S$ , = space described,

or 0.43429 :  $\log. \frac{e+t}{e} = 2ad : S$ ,

and  $S = \frac{2ad}{0.43429} \times \log. \frac{e+t}{e}$ ,

by hyperbolic logarithms  $S = 2ad \times \log. \frac{e+t}{e}$ .

Let the ball be a twelve pounder; the initial velocity 1600 feet, and the time twenty seconds. We must first find  $e$ , which is  $\frac{2ad}{V}$ .

Therefore, $\log. 2a$ . . . . .	+ 3.032 6
$\log. d (4, 5)$ . . . . .	+ 0.653 21
$\log. V. (1600)$ . . . . .	- 3.204 12

$\log. \text{of } 3''.03, = e$ . . . . .	0.481 45
And $e+t$ is $23''.03$ , of which the $\log.$ is	1.362 29
from which take the $\log.$ of $e$ . . . . .	0.481 45

remains the  $\log.$  of  $\frac{e+t}{e}$  . . . . . 0.880 84

This must be considered as a common number by which we are to multiply  $\frac{2ad}{0.43429}$ . Therefore

add the logarithms of $2ad$ . . . . .	+ 3.685 57
$\log. \frac{e+t}{e}$ . . . . .	+ 9.944 90
$\log. 0.43429$ . . . . .	- 9.637 78

$\log. S. 9833 \text{ feet}$  . . . . . 3.992 69

For the final velocity,  
 $OD : OC = AC : BD$ , or  $e+t : e = V : v$ .  
 $23''.03 : 3''.03 = 1600 : 210\frac{1}{2}, = v$ .

The ball has therefore gone 3278 yards, and its velocity is reduced from 1600 to 210.

The gradual progress of the ball, during some seconds of its motion, is as follows:—

T.	S.	Diff.	V.	Diff.
1	1383		1203	397
2	2456	1073	964	239
3	3336	880	804	160
4	4080	744	690	114
5	4725	645	604	86
6	5294	569	537	67

The first column shows the time of the motion; the second the space described; the third the differences of the spaces, showing the motion during each successive seconds; the fourth the velocity at the end of the time  $t$ ; and the last the differences of velocity, showing its diminution in each successive second. At the distance of 1000 yards the velocity is reduced to one-half, and at the distance of less than a mile it is reduced to one-third.

II. Required to determine the distance at which the initial velocity  $V$  is reduced to any other quantity  $v$ . This question is solved in the very same manner by substituting the logarithms of  $V$  and  $v$  for those of  $e+t$  and  $e$ ; for  $AC$ :

$$BD = OD : OC, \text{ and therefore } \log. \frac{AC}{BD} =$$

$$\log. \frac{OD}{OC}, \text{ or } \log. \frac{V}{v} = \log. \frac{e+t}{e}. \text{ Required to}$$

determine the distance which in the velocity of 1780 of a twenty-four pound ball (which is the medium velocity of such a ball discharged with sixteen pounds of powder), will be reduced to 1500. Here  $d$  is 5.68, and therefore

$$\text{the logarithm of } 2ad \text{ is } \dots + 3.78671$$

$$\log. \frac{V}{v} = 0.07433, \text{ of which the log. is } + 8.87116$$

$$\text{Log. } 0.43429 \dots \dots \dots - 9.63778$$

$$\text{Log. } 1047.3, \text{ feet or } 349 \text{ yards } \dots \dots \dots 3.02009$$

This reduction will be produced in about seven-eighths of a second.

III. To determine the time which a ball, beginning to move with a certain velocity, employs in passing over a given space, and the diminution of velocity which it sustains from the resistance of the air; proceed thus:—

$$2ad : S = 0.43429 : \log. \frac{e+t}{e} = t. \text{ Then to log.}$$

$\frac{e+t}{e}$  add  $\log. e$ , and we obtain  $\log. e+t$ , and

$e+t$ ; from which if we take  $e$  we have  $t$ . Then, to find  $v$ , say  $e+t : e = V : v$ .

These examples may be concluded by applying this last rule to Mr. Robins's experiments on a musket bullet of three-fourths of an inch in diameter, which had its velocity reduced from 1670 to 1425 by passing through 100 feet of air. Thus we do to discover the resistance which it sustained, and compare it with the resistance to a velocity of one foot per second. We must first ascertain the first term of our analogy. The ball was of lead, and therefore  $2a$  must be multiplied by  $d$  and by  $m$ , which expresses the ratio of the density of lead to that of cast iron,  $d$  is

$$0.75, \text{ and } m \text{ is } \frac{11.37}{7.21} = 1.577.$$

$$\text{Therefore } \log. 2a \quad 3.03236$$

$$d \quad 9.87506$$

$$m \quad 0.19782$$

$$\text{Log. } 2adm \quad 3.10524$$

and  $2adm = 1274.2$ . Now  $1274.2 : 100 =$

$$0.43429 : 0.03408 = \log. \frac{e+t}{e}. \text{ But } e = \frac{2adg}{V}$$

$= 0.763$ , and its logarithm  $= 9.88252$ , which, added to  $0.03408$ , gives  $9.91660$ , which is the log, of  $e+t$ ,  $= 0.825$ , from which take  $e$ , and there remains  $t = 0.062$ , or  $\frac{62}{1000}$  of a second,

for the time of passage. Now, to find the remaining velocity, say  $825 : 1670 = 1544 : v$ . But in Mr. Robins's experiment the remaining velocity was only 1425, the ball having lost 245; whereas by this computation it should have lost only 126. It appears, therefore, that the resistance is double of what it would have been if the resistance increased in the duplicate proportion of the velocity. Mr. Robins says it is nearly triple. But he supposes the resistance to slow motions much smaller than his own experiment, so often mentioned, fully warrants.

The time  $e$  in which the resistance of the air would extinguish the velocity is  $0.763$ . Gravity, or the weight of the bullet, would have done it in  $\frac{1670}{32}$  or  $52'$ ; therefore the resistance is  $\frac{52'}{0.763}$

times, or nearly sixty-eight times its weight, by this theory, or 5.97 pounds. If we calculate from Mr. Robins's experiment, we must say  $\log. \frac{V}{v} : 0.43429 = 100 : eV$ , which will be 630.23,

$$\text{and } e = \frac{630.23}{1670} = 0.3774, \text{ and } \frac{52}{0.3774} \text{ gives}$$

138 for the proportion of the resistance to the weight, and makes the resistance 12.07 pounds, fully double of the other.

With this velocity, which greatly exceeds that with which the air can rush into a void, there must be a statical pressure of the atmosphere equal to six pounds and a half. This will make up the difference; and allows us to conclude that the resistance, arising solely from the motion communicated to the air, follows very nearly the duplicate proportion of the velocity.

The next experiment, with a velocity of 1690 feet, gives a resistance equal to 157 times the weight of the bullet, and this bears a much greater proportion to the former than 1690 does to 1670<sup>2</sup>; which shows that, although these experiments clearly demonstrate a prodigious augmentation of resistance, yet they are by no means susceptible of the precision which is necessary for discovering the law of this augmentation, or for a good foundation of practical rules; and it is still greatly to be wished that a more accurate mode of investigation could be discovered.

We have thus explained, in detail, the principles and the process of calculation for the simple case of the motion of projectiles through the air. The learned reader will think that we have been



unreasonably prolix, and that the whole might have been comprised in less room, by taking the algebraic method. We acknowledge that it might have been done even in a few lines. But we have observed, and our observation has been confirmed by persons well versed in such subjects, that in all cases where the fluxionary process introduces the fluxion of a logarithm, there is a great want of distinct ideas to accompany the hand and eye. The solution comes out by a sort of magic or legerdemain, we cannot tell either how or why. We therefore thought it necessary to furnish the reader with distinct conceptions of the things and quantities treated of. For this reason, after showing, in Sir Isaac Newton's manner, how the spaces described in the retarded motion of a projectile followed the proportion of the hyperbolic areas, we showed the nature of another curve, where lines could be found which increase in the very same manner as the path of the projectile increases; so that a point describing the abscissa MI of this curve moves precisely as the projectile does. Then, discovering that this line is the same with the line of logarithms on a Gunter's scale, we showed how the logarithm of a number really represents the path or space described by the projectile.

SECT. V.—OF THE PERPENDICULAR ASCENTS AND DESCENTS OF HEAVY PROJECTILES.

Having thus enabled the reader to conceive distinctly the quantities employed, we shall leave the geometrical method, and prosecute the rest of the subject in a more compendious manner. We are next to consider the perpendicular ascents and descents of heavy projectiles, where the resistance of the air is combined with the action of gravity: and we shall begin with the descents.

Let  $u$ , as before, be the terminal velocity, and  $g$  the accelerating power of gravity: when the body moves with the velocity  $u$ , the resistance is equal to  $g$ ; and in every other velocity  $v$ , we must have  $u^2 : v^2 :: g : \frac{g v^2}{u^2} = r$ , for the resistance to that velocity. In the descent the body is urged by gravity  $g$ , and opposed by the resistance  $\frac{g v^2}{u^2}$ : therefore the remaining accelerating

force, which we shall call  $f$ , is  $g - \frac{g v^2}{u^2}$ , or  $\frac{g u^2 - g v^2}{u^2}$ , or  $\frac{g(u^2 - v^2)}{u^2} = f$ .

The fundamental theorem for varied motion is  $f \dot{s} = u \dot{v}$ , and  $\dot{s} = \frac{v \dot{v}}{f} = \frac{u}{g} \times \frac{\dot{v} v}{u^2 - v^2}$ , and  $s = \frac{u^2}{g} \times \int \frac{\dot{v} v}{u^2 - v^2} + C$ . Now the fluent of  $\frac{\dot{v} v}{u^2 - v^2}$  is  $= -\text{hyper. log. of } \sqrt{u^2 - v^2}$ . For the fluxion of  $\sqrt{u^2 - v^2}$  is  $-\frac{v \dot{v}}{\sqrt{u^2 - v^2}}$ , and this divided by the quantity  $\sqrt{u^2 - v^2}$ , of which it is the fluxion, gives precisely  $\frac{\dot{v} v}{u^2 - v^2}$ , which is therefore the fluxion of its hyperbolic logarithm. Therefore  $S = -\frac{u^2}{g} \times \text{L}\sqrt{u^2 - v^2} + C$ . Where  $\text{L}$  means

the hyperbolic logarithm of the quantity annexed to it, and  $\lambda$  may be used as to express its common logarithm. See article FLUXIONS.

The constant quantity  $C$  for completing the fluent is determined from this consideration, that the space described is  $o$ , when the velocity is  $o$ :

$$C - \frac{u^2}{g} \times \text{L}\sqrt{u^2} = o, \text{ and } C = \frac{u^2}{g} \times \text{L}\sqrt{u^2},$$

and the complete fluent  $S = \frac{u^2}{g} \times$

$$\text{L}\sqrt{u^2 - \text{L}\sqrt{u^2 - v^2}} = \frac{u^2}{g} \times \text{L}\sqrt{\frac{u^2}{u^2 - v^2}} =$$

$$\frac{u^2}{0.43429 g} \times \lambda \sqrt{\frac{u^2}{u^2 - v^2}} \text{ or (putting } M \text{ for } 0.43429, \text{ the modulus or subtangent of the com-}$$

$$\text{mon logistic curve)} = \frac{u^2}{Mg} \times \lambda \sqrt{\frac{u^2}{u^2 - v^2}}.$$

This equation establishes the relation between the space fallen through and the velocity acquired

by the fall. We obtain by it  $\frac{gS}{u^2} = \text{L}\sqrt{\frac{u^2}{u^2 - v^2}}$

and  $\frac{2gS}{u^2} = \text{L}\frac{u^2}{u^2 - v^2}$ , or, which is still more

convenient for us,  $\frac{M \times 2gS}{u^2} = \lambda \frac{u^2}{u^2 - v^2}$ , that is,

equal to the logarithm of a certain number: therefore having found the natural number cor-

responding to the fraction  $\frac{M \times 2gS}{u^2}$ , consider

it as a logarithm, and take out the number corresponding to it: call this  $n$ . Then, since  $n$  is

equal to  $\frac{u^2}{u^2 - v^2}$ , we have  $nu^2 - nv^2 = u^2$ , and  $nu^2 -$

$u^2 = n v^2$ , or  $n v^2 = u^2 \times \frac{n-1}{n}$ , and  $v^2 = \frac{u^2 \times n-1}{n}$ .

To expedite all the computations on this subject, it will be convenient to have multipliers ready computed for  $M \times 2g$ , and its half,

viz. 27.794, whose log. is . . . 1.44396  
and 13.897 . . . . . 1.14293

But  $v$  may be found much more expeditiously by

observing that  $\sqrt{\frac{u^2}{u^2 - v^2}}$  is the secant of an

arch of a circle whose radius is  $u$ , and whose

sine is  $v$ , or whose radius is unity and sine  $= \frac{v}{u}$ ;

therefore, considering the above fraction as a logarithmic secant, look for it in the tables, and then take the sine of the arc of which this is the secant, and multiply it by  $u$ ; the product is the velocity required.

An example may be given of a ball whose terminal velocity is 689½ feet, and ascertain its velocity after a fall of 1848 feet. Here,

$u^2 = 475200$ , and its log. . . . .	= 5.67688
$u = 689\frac{1}{2}$ . . . . .	2.83844
$g = 32$ . . . . .	1.50515
$\frac{g}{2} = 1848$ . . . . .	3.26670
Then log. 27.794 . . . . .	+ 1.44396
log. S . . . . .	+ 3.26670
log. $u^2$ . . . . .	- 5.67688

$$\text{Log. of } 0.10809 = \text{lo } .n \text{ . . . . . } 9.03378$$

0.10809 is the logarithm of  $1.2826 = n$ , and  $n - 1 = 0.2826$ , and  $\frac{n^2 \times n - 1}{n} = 323.6^2 = v^2$ ; and  $v = 323.6$ .

In like manner, 0.054045 (which is half of 0.10809) will be found to be the logarithmic secant of  $28^\circ$ , whose sine 0.46947 multiplied by 689½ gives 324 for the velocity. The process of this solution suggests a very perspicuous manner of conceiving the law of descent; and it may be thus expressed: M is to the logarithm of the secant of an arch whose sine is  $\frac{v}{u}$  and radius 1 as  $2a$  is to the height through which the body must fall to acquire the velocity  $v$ . Thus, to take the same example:—

1. Let the height  $h$  be sought which will produce the velocity 323.62, the terminal velocity of the ball being 689.34. Here  $2a$ , or  $\frac{u^2}{g}$  is 14850,

and  $\frac{323.62}{689.35} = 0.46947$ , which is the sine of  $28^\circ$ .

The logarithmic secant of this arch is 0.05407. Now M or 0.43429 : 0.05407 = 14850 : 1848, the height wanted.

2. Required the velocity acquired by the body by falling 1848 feet. Say 14850 : 1848 = 0.43429 : 0.05407. Look for this number among the logarithmic secants. It will be found at  $28^\circ$ , of which the logarithmic sine is . 9.67161  
Add to this the log. of  $u$  . . . 2.83844

The sum . . . . . 2.51005

is the logarithm of 323.62, the velocity required. From these solutions we see that the acquired velocity continually approaches to, but never equals, the terminal velocity. For it is always expressed by the sine of an arch of which the terminal velocity is the radius.

The motion of a body projected downwards next merits consideration. While the velocity of projection is less than the terminal velocity, the motion is determined by what we have already said; for we must compute the height necessary for acquiring this velocity in the air, and suppose the motion to have begun there. But, if the velocity of projection be greater, this method fails. We pass it over (though not in the least more difficult than what has gone before) because it is of mere curiosity, and never occurs in any interesting case. We may just observe that, since the motion is swifter than the terminal velocity, the resistance must be greater than the weight, and the motion will be retarded. The very same process will give us for the space

described  $S = \frac{u^2}{g} \times L\sqrt{\frac{V^2 - u^2}{v^2 - u^2}}$ ,  $V$  being the velocity of projection greater than  $u$ . Now as this space evidently increases continually (because the body always falls, but does not become infinite in any finite time), the fraction  $\frac{V^2 - u^2}{v^2 - u^2}$

does not become infinite; that is,  $v^2$  does not become equal to  $u^2$ : therefore, although the velocity  $V$  is continually diminished, it never becomes so small as  $u$ . Therefore  $u$  is a limit of diminution as well as of augmentation.

The relation between the time of the descent

and the space described, or the velocity acquired, must now be ascertained. For this purpose we may use the other fundamental proposition of varied motions  $f t = v$ , which, in the present

case, becomes  $\frac{g}{u^2} t^2 = v$ ; therefore  $t = \frac{u^2}{g} \times \frac{v}{u^2 - v^2} = \frac{u}{g} \times \frac{u v}{u^2 - v^2}$ , and  $t = \frac{u}{g} \times \int \frac{u v}{u^2 - v^2}$   
 $= \frac{u}{g} \times L\sqrt{\frac{u+v}{u-v}} = \frac{u}{Mg} \times \lambda \sqrt{\frac{u+v}{u-v}}$ .

This fluent needs no constant quantity to complete it, or rather  $C = 0$ ; for  $t$  must be  $= 0$  when  $v = 0$ . This will evidently be the case; for then

$L\sqrt{\frac{u+v}{u-v}}$  is  $L\sqrt{\frac{u}{u}} = L 1, = 0$ .

This rule may be illustrated by the same example. In what time will the body acquire the velocity 323.62? Here  $u + v = 1012.96$ ,  $u - v =$

$365.72$ ; therefore  $\lambda \sqrt{\frac{u+v}{u-v}} = 0.22122$ , and  $\frac{u}{g}$

(in feet and seconds) is  $21'' . 542$ . Now, for greater perspicuity, convert the equation  $t =$

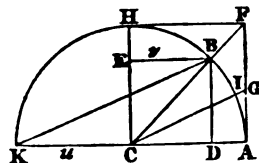
$\frac{u}{Mg} \times \lambda \sqrt{\frac{u+v}{u-v}}$  into a proportion: thus M :  $\lambda$

$\sqrt{\frac{u+v}{u-v}} = \frac{u}{g} : t$ , and we have 0.43429 :

0.22122 =  $21'' . 542 : 10'' . 973$ , the time required.

We should remember that the numbers or symbols which we call logarithms are really parts of the line MI in the figure of the logistic curve, and that the motion of a point in this line is precisely similar to that of the body. The marquis Peleni, in a dissertation published at Padua in 1725, has with great ingenuity constructed logarithmics suited to all the cases which can occur.

It is easy to see that  $\sqrt{\frac{u+v}{u-v}}$  is the cotangent of the  $\frac{1}{2}$  complement of an arch whose radius is 1, and whose sine is  $\frac{v}{u}$ : For let KC (see diagram) be  $= u$ , and BE  $= v$ ; then KD  $= u + v$ ,



and DA  $= u - v$ . Join KB and BA, and draw CG parallel to KB. Now GA is the tangent of  $\frac{1}{2}$  BA,  $= \frac{1}{2}$  complement of HB. Then, by similarity of triangles, GA : AC  $=$  AB : Bk,  $= \sqrt{AD} : \sqrt{Dk} = \sqrt{u-v} : \sqrt{u+v}$  and  $\frac{AC}{GA}$

$(= \cotan. \frac{1}{2} BA) = \sqrt{\frac{u+v}{u-v}}$ ; therefore look

for  $\frac{v}{u}$  among the natural sines, or for  $\log. \frac{v}{u}$  among the logarithmic sines, and take the logarithmic cotangent of the half complement of the corresponding arch. This, considered as a common number, will be the second term of our proportion. This is a shorter process than the former

By reversing this proportion we get the velocity corresponding to a given time. To compare this descent of 1848 feet in the air with the fall of the body in vacuo during the same time, say  $21'' \cdot 542^2 : 10'' \cdot 973 = 1848 : 1926 \cdot 6$ , which makes a difference of seventy-nine feet.

COR. 1. The time in which the body acquires the velocity  $u$  by falling through the air is, to the time of acquiring the same velocity by falling in vacuo, as  $u \text{ L}\sqrt{\frac{u+v}{u-v}}$  to  $v$ ; for it would acquire this velocity in vacuo during the time  $\frac{v}{g}$ , and it acquires it in the air in the time  $\frac{u}{g} \text{ L}\sqrt{\frac{u+v}{u-v}}$ .

2. The velocity which the body acquires by falling through the air in the time  $\frac{u}{g} \text{ L}\sqrt{\frac{u+v}{u-v}}$  is, to the velocity which it would acquire in vacuo during the same time as  $v$  to  $u \text{ L}\sqrt{\frac{u+v}{u-v}}$ ; for the velocity would acquire in vacuo during the time  $\frac{u}{g} \text{ L}\sqrt{\frac{u+v}{u-v}}$  must be  $u \text{ L}\sqrt{\frac{u+v}{u-v}}$  (because in any time  $\frac{w}{g}$  the velocity  $w$  is acquired).

Next, let a body whose terminal velocity is  $u$  be projected perpendicularly upwards, with any velocity  $V$ . It is required to determine the height to which it ascends, so as to have any remaining velocity  $v$ , and the time of its ascent; as also the height and time in which its whole motion will be extinguished. We have now  $\frac{g(u^2 + v^2)}{u^2}$  for the expression of  $f$ ; for both gravity and resistance act now in the same direction and retard the motion of the ascending body; therefore  $\frac{g(u^2 + v^2)}{u^2}$

$\dot{s} = -v \dot{t}$ , and  $\dot{s} = -\frac{u^2}{g} \times \frac{v \dot{v}}{u^2 + v^2}$  and  $\dot{s} = -\frac{u^2}{g} \times \int \frac{v \dot{v}}{u^2 + v^2} + C = -\frac{u^2}{g} \times \text{L}\sqrt{u^2 + v^2} + C$  (see art. FLUXIONS). This must be  $= 0$  at the beginning of the motion, that is, when  $v=V$ , that is,  $-\frac{u^2}{g} \times \text{L}\sqrt{u^2 + V^2} + C = 0$ , or  $C = \frac{u^2}{g} \times \text{L}\sqrt{u^2 + V^2}$ , and the complete fluent will be  $s = \frac{u^2}{g} \times (\text{L}\sqrt{u^2 + v^2} - \text{L}\sqrt{u^2 + V^2}) = \frac{u^2}{g} \times \text{L}\sqrt{\frac{u^2 + V^2}{u^2 + v^2}} = \frac{u^2}{\lambda g} \times \lambda \sqrt{\frac{u^2 + V^2}{u^2 + v^2}}$

Let  $h$  be the greatest height to which the body will rise. Then  $s = h$  when  $v = 0$ ; and  $h = \frac{u^2}{g} \times \text{L}\sqrt{\frac{u^2 + V^2}{u^2}} = \frac{u^2}{\lambda g} \times \lambda \sqrt{\frac{u^2 + V^2}{u^2}}$ . We have  $\lambda \sqrt{\frac{u^2 + V^2}{u^2 + v^2}} = s \frac{u g}{u^2}$ ; therefore  $\lambda$

$\left(\frac{u^2 + V^2}{u^2 + v^2}\right) = \frac{2 M g s}{u^2}$ . Therefore let  $u$  be the number whose common logarithm is  $\frac{2 M g s}{u^2}$ ; we

shall have  $u = \frac{u^2 + V^2}{u^2 + v^2}$ , and  $v = \frac{u^2 + V^2}{u^2} - u^2$ ; and thus we obtain the relation of  $s$  and  $v$ , as in the case of descents; but we obtain it still easier by observing that  $\sqrt{u^2 + V^2}$  is the secant of an arch whose radius is  $u$ , and whose tangent is  $V$ , and that  $\sqrt{u^2 + v^2}$  is the secant of another arch of the same circle whose tangent is  $v$ .

Let the same ball be projected upwards with the velocity 411.05 feet per second. Required the whole height to which it will rise? Here  $\frac{V}{u}$  will be found the tangent of  $30 \cdot 48 \frac{1}{2}$ , the logarithmic secant of which is 0.06606. This, multiplied by  $\frac{u^2}{Mg}$ , gives 2259 feet for the height. It would have risen 2640 feet in a void.

Suppose this body to fall down again. We can compare the velocity of projection with the velocity with which it again reaches the ground. The ascent and descent are equal; therefore  $\sqrt{\frac{u^2 + V^2}{u^2}}$ , which multiplies the constant factor

in the ascent, is equal to  $\sqrt{\frac{u^2}{u^2 - v^2}}$ , the multiplier in the descent. The first is the secant of an arch whose tangent is  $V$ ; the other is the secant of an arch whose sine is  $v$ . These secants are equal, or the arches are the same; therefore the velocity of projection is to the final returning velocity as the tangent to the sine, or as the radius to the cosine of the arch. Thus suppose the body projected with the terminal velocity, or  $V = u$ ; then  $v = \frac{u}{\sqrt{2}}$ . If  $V = 689$ ,  $v = 487$ .

Lastly, the relation of the space and the time must be ascertained. Here  $\frac{g(u^2 + v^2)}{u^2} \dot{t} = -\dot{s}$

and  $\dot{t} = -\frac{u^2}{g} \times \frac{\dot{v}}{u^2 + v^2} = -\frac{u}{g} \times \frac{u \dot{v}}{u^2 + v^2}$ , and  $\dot{t} = \frac{-u}{g} \times \int \frac{u \dot{v}}{u^2 + v^2} + C$ . Now (art. FLUXIONS)  $\int \frac{u \dot{v}}{u^2 + v^2}$ , is an arch whose tangent  $= \frac{v}{u}$ , and radius 1; therefore  $t = -\frac{u}{g} \times \text{arc. tan.} \frac{v}{u} + C$ . This must be  $= 0$ , when  $v = V$ , or  $C = \frac{u}{g} \times \text{arc. tan.} \frac{V}{u} = 0$ , and  $C = \frac{u}{g} \times \text{arc. tan.} \frac{V}{u}$  and the complete fluent is  $t = \frac{u}{g} \times (\text{arc. tan.} \frac{V}{u} - \text{arc. tan.} \frac{v}{u})$ . The quantities within the brackets express a portion of the arch of a circle whose radius is unity; and are therefore abstract numbers, multiplying  $\frac{u}{g}$ , which we have shown to be the number of units of time in which a heavy body falls in vacuo from the height  $u$ , or in which it acquires the velocity  $u$ .

From this expression of the time we learn that however great the velocity of projection, and the height to which this body will rise, may be the time of its ascent is limited. It never can exceed the time of falling from the height  $a$  in vacuo in a greater proportion than that of a quadrantal arch to the radius, nearly the proportion of eight to five. A twenty-four pound iron ball cannot continue rising above fourteen seconds, even if the resistance to quick motions did not increase faster than the square of the velocity. It probably will attain its greatest height in less than twelve seconds, let its velocity be ever so great. In the preceding example of the whole

ascent  $v = a$ , and the time  $t = \frac{u}{g} \times \text{arc. tan. } \frac{V}{u}$

or  $\frac{u}{g} \text{arc. } 30^\circ 48'$ . Now  $30^\circ 48' = 1848'$ , and the

radius 1 contains 3483: therefore the arch  $= \frac{1848}{3483}$

$= 0.5376$ ; and  $\frac{u}{g} 21''.54$ . Therefore  $t = 21''.54$

$\times 0.5376$ ,  $+ 11''.58$ , or nearly  $11\frac{1}{2}$  seconds. The body would have risen to the same height in a void in  $10\frac{1}{2}$  seconds.

Cor. 1. The time in which a body, projected in the air with any velocity  $V$ , will attain its greatest height, is to that in which it would attain its greatest height in vacuo as the arch whose tangent expresses the velocity is to the tangent;

for the time of the ascent in the air is  $\frac{u}{g} \times \text{arch}$ ;

the time of the ascent in vacuo is  $\frac{V}{g}$ . Now  $\frac{V}{g}$  is

$= \text{tan.}$  and  $V = u \times \text{tan.}$  and  $\frac{V}{u} = \frac{u}{u} \times \text{tan.}$

From inspecting the diagram p. 153, it is evident that the arch  $AI$  is to the tangent  $AG$  as the sector  $ICA$  to the triangle  $CGA$ ; therefore the time of attaining the greatest height in the air is to that of attaining the greatest height in vacuo (the velocities of projection being the same) as the circular sector to the corresponding triangle. If therefore a body be projected upwards with the terminal velocity, the time of its ascent will be to the time of acquiring this velocity in vacuo as the area of a circle to the area of the circumscribed square.

2. The height  $H$  to which a body will rise in a void is to the height  $h$  to which it would rise through the air when projected with the same

velocity  $V$  as  $M \cdot V^2$  to  $u^2 \times \lambda \frac{u^2 + V^2}{u^2}$ ; for the

height to which it will rise in vacuo is  $\frac{V^2}{2g}$ , and

the height which it rises in the air is  $\frac{u^2}{Mg} \lambda$

$\sqrt{\frac{u^2 + V^2}{u^2}}$ ; therefore  $H : h = \frac{V^2}{2g} : \frac{u^2}{Mg} \lambda$

$\sqrt{\frac{u^2 + V^2}{u^2}} = V^2 : \frac{u^2}{M} \times 2 \lambda \sqrt{\frac{u^2 + V^2}{u^2}} = V^2 :$

$\frac{u^2}{M} \times \lambda \frac{u^2 + V^2}{u^2} = M \cdot V^2 : u^2 \times \lambda \frac{u^2 + V^2}{u}$ .

If the body, therefore, be projected with its terminal velocity, so that  $V = u$ , the height to

which it will rise in the air is  $\frac{30103}{43429}$  of the height

to which it will rise in vacuo, or  $\frac{5}{7}$  in round numbers.

We thought it necessary to treat of the perpendicular ascents and descents of heavy bodies through the air thus particularly, that the reader may conceive distinctly the quantities which he is thus combining in his algebraic operations, and may see their connexion in nature with each other. We shall also find that, in the present state of our mathematical knowledge, this simple state of the case contains almost all that we can determine with any confidence.

SECT. VI.—OF THE OBLIQUE PROJECTION.

We would now proceed to the general problem to determine the motion of a body projected in any direction, and with any velocity. But our readers will believe that this must be a difficult subject, when they see the simplest cases of rectilinear motion abundantly abstruse: it is indeed so difficult that Sir Isaac Newton has not given a solution of it, and has thought himself well employed in making several approximations, in which the fertility of his genius appears in great lustre. In the tenth and subsequent propositions of the second book of his Principia he shows what state of density in the air will comport with the motion of a body in any curve whatever; and then, by applying this discovery to several curves which have some similarity to the path of a projectile, he finds one which is not very different from what we may suppose to obtain in our atmosphere. But even this approximation was involved in such intricate calculations that it seemed impossible to make any use of it.

In the second edition of the Principia, published in 1713, Newton corrects some mistakes in the first, and carries his approximations much farther, but still does not attempt a direct investigation of the path which a body will describe in our atmosphere. This is somewhat surprising. In prop. 14, &c., he shows how a body, actuated by a centripetal force, in a medium of density varying according to certain law, will describe an eccentric spiral, of which he assigns the properties, and the law of description. Had he supposed the density constant, and the difference between the greatest and least distances from the centre of centripetal force exceedingly small in comparison with the distances themselves, his spiral would have coincided with the path of a projectile in the air of uniform density, and the steps of his investigation would have led him immediately to the complete solution of the problem. For this is the real state of the case. A heavy body is not acted on by equal and parallel gravity, but by a gravity inversely proportional to the square of the distance from the centre of the earth, and in lines tending to that centre nearly; and it was with the view of simplifying the investigation that mathematicians have adopted the other hypothesis.

Not long after the publication of this second edition of the Principia, the dispute about the in-

vention of the fluxionary calculus became very violent, and the great promoters of that calculus upon the continent proposed difficult problems to the mathematicians. Challenges of this kind frequently passed between the British and foreigners. Dr. Keill of Oxford had keenly espoused the claim of Sir Isaac Newton to this invention, and had engaged in a very acrimonious altercation with the celebrated John Bernouilli of Basle. Bernouilli had published in the *Acta Eruditorum Lipsiæ*, an investigation of the law of forces, by which a body, moving in a resisting medium, might describe any proposed curve, reducing the whole to the simplest geometry. This is perhaps the most elegant specimen which he has given of his great talents. Dr. Keill proposed to him the particular problem of the trajectory and motion of a body moving through the air, as one of the most difficult. Bernouilli very soon solved the problem in a way much more general than it had been proposed, viz. without any limitation either of the law of resistance, the law of the centripetal force, or the law of density, provided only that they were regular, and capable of being expressed algebraically. Dr. Brooke Taylor, the celebrated author of the *Method of Increments*, solved it at the same time, in the limited form in which it was proposed. Other authors since that time have given other solutions; but they are all (as indeed they must be) the same in substance with Bernouilli's. Indeed they are all (Bernouilli's not excepted) the same with Newton's first approximations, modified by the steps introduced into the investigation of the spiral motions mentioned above; and we still think it most strange that Sir Isaac did not perceive that the variation of curvature, which he introduced in that investigation, made the whole difference between his approximations and the complete solution.

All the solutions given of this problem depend upon a particular law of resistance assumed, without proving that to be the law by which a body is resisted in its motion through the air. This resistance is supposed to be in the duplicate ratio of the velocity; but even theory points out many causes of deviation from this law, such as the pressure and condensation of the air, in the case of very swift motions: and Mr. Robins's experiments are sufficient to prove that the deviations must be exceedingly great in such cases. Euler and all subsequent writers have allowed that it may be three times greater, even in cases which frequently occur; and Euler gives a rule for ascertaining with tolerable accuracy what this increase and the whole resistance may amount to. Let  $H$  be the height of a column of air whose weight is equivalent to the resistance taken in the duplicate ratio of the velocity. The whole resistance will be expressed by  $H + \frac{H^2}{28845}$ . This number 28845 is the height in feet of a column of air whose weight balances its elasticity. We shall not at present call in question his reasons for assigning this precise addition. They are rather reasons of arithmetical conveniency than of physical import. It is enough to observe that, if this measure of the resistance is introduced into the process of inves-

tigation, it is totally changed: and it is not too much to say that with this complication it requires the knowledge and address of a Euler to make even a partial and very limited approximation to a solution.

Any law of the resistance, therefore, which is more complicated than what Bernouilli has assumed, namely, that of a simple power of the velocity, is abandoned by all the mathematicians, as exceeding their data: and they have attempted to avoid the error arising from the assumption of the duplicate ratio of the velocity either by supposing the resistance throughout the whole trajectory to be greater than what it is in general, or they have divided the trajectory into different portions, and assigned different resistances to each, which vary, through the whole of that portion, in the duplicate ratio of the velocities. Thus they make up a trajectory and motion which corresponds, in some tolerable degree, with what? With an accurate theory? No; but with a series of experiments. For, in the first place, every theoretical computation which we make proceeds on a supposed initial velocity; and this cannot be ascertained with any thing approaching to precision by any theory of the action of gunpowder that we are yet possessed of. In the next place, our theories of the resisting power of the air are entirely established on the experiments on the flight of shot and shells, and are corrected and amended till they tally with the most approved experiments we can find. We do not learn the ranges of a gun by theory, but the theory by the range of the gun.

After all, therefore, the practical artillerist must rely chiefly on the records of experiments contained in the books of practice at the academies, or those made in a more public manner. Even a perfect theory of the air's resistance can do him little service, unless the force of gunpowder were uniform. But this is far from being the case.

The experiments of Mr. Robins and Dr. Hutton show, in the most incontrovertible manner, that the resistance to a motion exceeding 1100 feet in a second is almost three times greater than in the duplicate ratio to the resistance to moderate velocities. Euler's translator, in his comparison of the author's trajectories with experiment, supposes it to be no greater. Yet the coincidence is very great. The same may be said of the Chevalier de Borda's. Nay, the same may be said of Mr. Robins's own practical rules; and yet his rules are confirmed by experience.

But we must not infer, from all this, that the physical theory is of no use to the practical artillerist. It plainly shows him the impropriety of giving the projectile an enormous velocity. This velocity is of no effect after 200 or 300 yards at farthest, because it is so rapidly reduced by the prodigious resistance of the air. Mr. Robins has deduced several practical maxims of the greatest importance from what we already know of this subject, and which could hardly have been even conjectured without this knowledge. And we must still acknowledge that this branch of physical science is highly interesting to the philosopher; nor should we despair of carrying it to greater perfection.

Certainly the most complete set of experiments made with a view of obtaining a rational theory of projectiles are those of Dr. Hutton, which were carried on at Woolwich during the years 1775, 1783, 1784, 1785, 1787, 1788, 1789, and 1791, the objects of which were very various, and some of the results highly important. The latter are thus enumerated by the author in the second volume of his Tracts:—

'1. It is made evident, by these experiments, that powder fires almost instantaneously, seeing that nearly the whole of the charge fires, though the time be much diminished.

'2. The velocities communicated to the shot of the same weight, with different quantities of powder, are nearly in the subduplicate ratio of those quantities; a very small variation, in defect, taking place when the quantities of powder become great.

'3. And when shot of different weights are fired with the same quantities of powder the velocities communicated to them are nearly in the reciprocal subduplicate ratio of their weights.

'4. So that, universally, shots which are of different weights, and impelled by the firing of different quantities of powder, acquire velocities which are directly as the square roots of the quantity of powder, and inversely as the square roots of the weight of the shot, nearly.

'5. It would therefore be a great improvement in artillery to make use of shot of a long form, or of heavier matter; for thus the momentum of the shot, when fired with the same weight of powder, would be increased in the ratio of the square root of the weight of the shot.

'6. It would also be an improvement to diminish the windage; for, by so doing, one-third or more of the quantity of powder might be saved.' (This, however, must be understood only to be true within certain limits.)

'7. When the improvements mentioned in the two last cases are considered as both taking place it is evident that about half the quantity of powder might be saved, which is a very considerable object. But, important as this saving may be, it seems still to be exceeded by that of the guns: for thus a small gun may be made to have the effect of one of two or three times its size, in the present way, by discharging a long shot of two or three times the weight of its natural ball, or round shot: and thus a small ship might discharge shot as heavy as those of the greatest now made use of.'

The objects of the latter courses of experiments are thus detailed: viz. to ascertain,

'1. The velocities with which balls are projected by equal charges of powder, from pieces of the same weight and calibre, but of different lengths.

'2. The greatest velocities due to the different charges of powder, the weight and length of the gun being the same.

'3. The greatest velocity due to the different lengths of guns; to be obtained by increasing the charge as far as the resistance of the piece is capable of sustaining.

'4. The effect of varying the weight of the piece; every thing else being the same.

'5. The penetration of balls into blocks of wood.

'6. The ranges and times of flight of balls, with the velocities, by striking the pendulum at various distances, to compare them with initial velocities, for determining the resistance of the medium.

'7. The effects of wads, of ramming, of windage, &c.'

We shall now quote this author's expression for the resistance of the air, deduced from these experiments, and thence determine the ranges, times of flight, &c., of projectiles according to that hypothesis.

**THEOREM.**—The resistance of the air, to a ball projected into it with any considerable velocity, is expressed by the formula  $r = (.000007565 v^2 - .00175 v) d^2$ . But, for the smaller velocities,  $r = .0000044 d^2 v^2$  will be a sufficiently near approximation, where  $r$  represents the resistance in avoirdupois pounds,  $d$  the diameter of the ball in inches,  $v$  the velocity in English feet. See Hutton's Tracts, vol. iii. p. 232.

**PROB. I.**—To determine the height to which a ball, projected perpendicularly upwards, will ascend, being resisted by the atmosphere.

Putting  $x$  to denote any variable and increasing height ascended by the ball;  $v$  its variable and decreasing velocity there;  $d$  the diameter of the ball, its weight being  $w$ ;  $m = .000007565$ , and  $n = .00175$ , the co-efficients of the two terms in the above theorem. Then  $(m v^2 - n v) d^2$  will be the resistance of the air against the ball in avoirdupois pounds, to which, if the weight of the ball be added, then  $(m v^2 - n v) d^2 + w$  will be the whole resistance to the ball's motion, and

$$\text{consequently } \frac{(m v^2 - n v) d^2 + w}{w} = \frac{(m v^2 - n v) d^2 + w}{w}$$

$d^2 + 1 = f$ , the retarding force. Hence the general formula  $v \dot{v} = 2 g f x$  becomes  $-v \dot{v} = 2 g x \times \frac{(m v^2 - n v) d^2 + w}{w}$  making  $v$  negative, be-

cause the velocity is decreasing, where  $g = 16\frac{1}{2}$  feet, or sixteen feet, the descent of a body in one second by gravity.

$$\text{Hence } \dot{x} = -\frac{w}{29} \times \frac{v \dot{v}}{(m v^2 - n v) d^2 + w} = -\frac{w}{2 g m d^2} \times \frac{v \dot{v}}{v^2 - \frac{n}{m} v + \frac{w}{m d^2}}$$

The fluent of which being taken, and corrected for the instant of the first velocity  $V$ , when  $x = 0$ , gives  $x =$

$$\frac{w}{2 g m d^2} \times \left\{ \frac{1}{2} \log. \left( V^2 - \frac{n}{m} V + \frac{w}{m d^2} \right) - \frac{1}{2} \log. \frac{w}{m d^2} + \frac{p}{q^2} (\text{arc. tan. } (V - p) - \text{arc. tan. } - p \text{ to rad. } q) \right\}$$

where  $p = \frac{n}{2m}$ , and  $p^2 + q^2 = \frac{w}{m d^2}$ .

But as part of this fluent, denoted by  $\frac{p}{q^2}$  + the difference of the two arcs to  $\tan. (V - p)$  and  $-p$ , is always very small in comparison with the other preceding terms, it may be omitted without any material error in practical cases; in which case we have,

$$x = \frac{w}{4gm d^2} \times \text{hyp. log.} \frac{V^2 - \frac{n}{m}V + \frac{w}{m d^2}}{\frac{w}{m d^2}}$$

for the greatest height to which the ball will ascend in air; supposing its density uniformly the same as at the earth's surface. Now for the numerical value of the general coefficient

$$\frac{w}{4gm d^2}$$

and the term  $\frac{w}{m d^2}$ ; because the mass of the ball to the diameter  $d$  is  $\cdot 5236 d^3$ , if its specific gravity be  $s$ , its weight will be  $\cdot 5236 s d^3 = w$ ; therefore  $\frac{w}{d^3} = \cdot 5236 s d$ , and  $\frac{w}{m d^2} = 69259 s d$ ;

this divided by  $4g$  or  $64$ , gives  $\frac{w}{4gm d^2} = 1082 s d$  for the value of the general coefficient, to any diameter  $d$ , and specific gravity  $s$ . And if we farther suppose the ball to be cast iron, the specific gravity of which, or the weight of a cubic inch, is  $\cdot 26855$  lbs., it becomes  $290 \cdot s d$  for that co-efficient; also  $69259 s d = 18600 d = \frac{w}{m d^2}$

$$\text{and } \frac{n}{m} = 231 \cdot 5.$$

Hence the preceding fluent becomes

$$x = 290 \cdot 6 \times \text{hyp. log.} \frac{V^2 - 231 \cdot 5 V + 18600 d}{18600 d}$$

$$x = 669 d \times \text{com. log.} \frac{V^2 - 231 \cdot 5 V + 18600 d}{18600 d}$$

which is in general expression for the altitude in feet ascended by an iron bullet whose diameter is  $d$ , and projectile velocity  $V$ .

*Example 1.*—Suppose a ball of cast iron, whose diameter is two inches, and, therefore, its weight  $1\frac{1}{2}$  lb., to be projected upwards with a velocity of 2000 feet per second, to find the greatest height to which it will ascend.

Here, substituting for  $d$ ,  $w$ , and  $V$  their respective values, we have

$$x = 669 d \times \text{com. log.} \frac{V^2 - 231 \cdot 5 V + 18600 d}{18600 d}$$

$$= 2653 \text{ feet.}$$

*Example 2.*—Again, let the ball weigh twenty-four pounds, and, therefore, its diameter  $5 \cdot 6$ , and velocity 2000 feet per second, as before; then

$$x = 669 d \times \text{com. log.} \frac{V^2 - 231 \cdot 5 V + 18600 d}{18600 d}$$

$$= 5782 \text{ feet, the height required.}$$

In the first of these examples, where the height is found to be only about half a mile, the ball would ascend to nearly twelve miles in a non-resisting medium; and hence we may see the immense effect of atmospheric resistance to the motion of projectiles.

PROB. II.—To determine the time in which a ball will have acquired its greatest height, using the same formula of resistance as in the last case.

Here the general value of  $t$ , determined on principles similar to those above employed, gives

$$t = \frac{w}{2gm q d^2} \times \left( \text{arc. tan.} \frac{V-p}{q} \text{arc. tan.} \frac{v-p}{q} \right),$$

$$\text{or } t = \frac{w}{2gm q d^2} \times \text{arc. tan.} \frac{V-p}{q}, \text{ rejecting}$$

the latter arc as inconsiderable;  $p$  and  $q$  representing the same as before.

*Example 1.*—Let it be proposed to find the time in which an iron ball, two inches in diameter, will acquire its greatest height, when projected with a velocity of 2000 feet per second.

$$\text{Here } \frac{n}{2m} = 115\frac{1}{2} = p, \text{ and } \frac{w}{m d^2} = p^2 + q^2, \text{ gives } q = \sqrt{37153 - p^2} = 154\frac{1}{2}; \text{ whence } t = \frac{w}{2gm q d^2} \times \left( \text{arc. tan.} \frac{V-p}{q} \right) = 11 \cdot 81 \text{ seconds.}$$

If we take the second example above to find the time, we shall have  $p = 115\frac{1}{2}$  as before, and  $q = 299 \cdot 4$ ; therefore  $t = \frac{w}{2gm q d^2} \times \text{arc. tan.}$

$$\frac{V-p}{q} = 16 \cdot 89 \text{ seconds.}$$

After the investigation of these problems, and some others of a similar nature, Dr. Hutton proceeds to the investigation of his principal one, viz. to determine the circumstances of ranges at different degrees of elevation; which we transcribe.

‘Rules for the general solution of this problem would be best derived from experiments; and these should be made at all elevations, and with all charges, and with various sizes of balls, observing both the ranges and times of flight in every experiment. Such experiments would give us the relations existing, in all cases, amongst these four terms, viz. the ranges, the times of flight, the velocity or charges, and the size of the balls. Numerous and various as are our experiments, as before related, and fruitful as they are in useful consequences, we have obtained but a small portion of those alluded to; nor do I know of any proper set of such experiments any where to be found. Such must, therefore, still remain a valuable desideratum; the few that we have been able to make afford us but very few and imperfect rules, being chiefly as follows:—1. That the ranges with the one-pound balls, at an elevation of  $15^\circ$ , are nearly proportional to the times of flight. 2. That the ranges with the three-pound balls, at  $45^\circ$  of elevation, are nearly as the times of flight, and also as the projectile velocities. Besides these inferences, it does not appear that the experiments are extensive enough to afford any more useful conclusion.

By trials, however, amongst many of the numbers in art. 24, it appears that in most of them at an elevation between  $45^\circ$  and  $30^\circ$ , the time of flight is nearly equal to one-fourth of the square root of the range in feet, in which respect it nearly agrees with the similar rule for the time of flight in the parabolic theory, at the angle of  $45^\circ$  for the greatest range, which time, it is well known, is equal to one-fourth of the square root of the said range in feet. Whence it is probable that, with the help of a few other ranges at several elevations, some general relations might be evinced between the ranges and the times of flight, with the tangents of the elevation.

‘But such experiments and enquiries as these, unfortunately, it is no longer in my power either to procure, or by any means to promote; and

we can, therefore, only endeavour to render, without them, what service we can to the state, and to philosophy, by such means as are in our power.

There are some few theoretical principles which it may be useful to notice here, as first mentioned by professor Robison. Thus balls of equal density, discharged at the same elevation with velocities which are proportional to the square roots of their diameters, will describe similar curves; because then the resistances will be in proportion as the momentum or quantity of motion. For the resistance  $r$  is  $d^2 v^2$  nearly;  $d$  being the diameter, and  $v$  the velocity. But  $v$  being as  $\sqrt{d}$ ,  $v^2$  will be as  $d$ ; consequently  $d^2 v^2$  will be as  $d^3$ ; that is,  $r$  is as  $d^3$ . But the momentum is as the magnitude or mass, which is as  $d^3$  also, the cube of the diameter. Therefore the resistance is proportional to the momentum, when the velocity is as  $\sqrt{d}$ , or the square root of the diameter of the ball. In this case, then, the horizontal velocity at the vertex of the curve will be proportional to the terminal velocity; also the ranges, and heights, and all other similar lines in the curve, will be proportional to  $d$ , the diameter of the ball. And this principle may be of considerable use; for thus, by means of a proper series of experiments on one ball, projected with different velocities and elevations, tables may be constructed, by which may be ascertained the motions in all similar cases.

We shall have occasion to advert again to these valuable contributions of Dr. Hutton.

PART II.

OF THE PRACTICE OF GUNNERY, OR MILITARY PROJECTILES.

Having laid before our readers the substance of the latest and most improved theories of projectiles, we proceed to give them a brief sketch of the most improved modern practice.

Mr. Robins, in his preface to his *New Principles of Gunnery*, states that he had met with only four authors who had treated experimentally on this subject. The first of these is Collado in 1642, who has given the ranges of a falconet, carrying a three-pound shot, to every point of the gunner's quadrant, each point being the twelfth part, or  $7^\circ 30'$ . But from his numbers it is manifest that the piece was not charged with its usual allotment of powder. The result of his trials shows the ranges at the point-blanc, and the several points of elevations as below.

Elevation at		Range in paces.
Points.	Deg.	
0 or	0	268
1	7½	594
2	15	794
3	22½	954
4	30	1010
5	37½	1040
6	45	1053
7	52½	between the 3d and 4th
8	60	between the 2d and 3d
9	67½	between the 1st and 2d
10	75	between the 0 and 1st
11	82½	fell very near the piece.

The next was by Wm. Bourne, in 1643, in his *Art of Shooting in great Ordnance*. His elevations were not regulated by the points of the gunner's quadrant, but by degrees; and he gives the proportions between the ranges at different elevations and the extent of the point-blanc shot, thus: if the extent of the point-blanc shot be represented by one, then the proportions of the ranges at several elevations will be as below, viz.--

BOURNE'S PROPORTION OF RANGES.

Elevation.	Range.
0°	1
5	2½
10	3½
15	4½
20	4¾
and the greatest random 5½;	

which greatest random, he says, in a calm day is at  $42^\circ$  elevation; but according to the strength of the wind, and as it favors or opposes the flight of the shot, the elevation may be from  $43^\circ$  to  $36^\circ$ . He does not say with what piece he made his trials, though from his proportion it seems to have been a small one. This however ought to have been mentioned, as the relation between the extent of different ranges varies extremely according to the velocity and density of the bullet.

After him Eldred and Anderson, both Englishmen, also published treatises on this subject. The former of these was many years gunner of Dover Castle, where most of his experiments were made, the earliest of which are dated 1611, though his book was not published till 1646, and was entitled *The Gunner's Glass*. His principles were simple, and within certain limits very near the truth, though they were not rigorously so. He has given the actual ranges of different pieces of artillery at small elevations, all under  $10^\circ$ . His experiments are numerous, and appear to be made with great care and caution; and he has honestly set down some which were not reconcilable to his method: upon the whole he seems to have taken more pains, and to have had a juster knowledge of his business than is to be found in most of his practical brethren.

Galileo printed his *Dialogues on Motion* in the year 1646. In these he pointed out the general laws observed by nature in the production and composition of motion, and was the first who described the actions and effects of gravity on falling bodies: on these principles he determined that the flight of a cannon-shot, or of any other projectile, would be in the curve of a parabola, unless so far as it should be diverted from that track by the resistance of the air. He also proposed the means of examining the inequalities which arise thence, and of discovering what sensible effects that resistance would produce in the motion of a bullet at some given distance from the piece. Notwithstanding these determinations and hints it seems, however, that those who came after Galileo never imagined that it was necessary to consider how far the operations of gunnery were affected by this resistance. Instead of this, they boldly asserted, without making the experiment, that no great variation could



rise from the resistance of the air in the flight of shells or cannon-shot. In this persuasion they supported themselves chiefly by considering the extreme rarity of the air, compared with those dense and ponderous bodies; and at last it became an almost generally established maxim that the flight of these bodies was nearly in the curve of a parabola.

After the publication of Newton's Principia it might have been expected that the defects of the theory would be ascribed to their true cause, the great resistance of the air to such swift motions; as in that work he particularly considered the subject of such motions, and related the result of experiments made on slow motions at least; by which it appeared that in such motions the resistance increases as the square of the velocities, and he even hints a suspicion that it will increase above that law in swifter motions, as is now known to be the case. So far, however, were those who treated this subject scientifically from making a proper allowance for the resistance of the atmosphere that they still neglected it, or rather opposed it, and their theories accordingly differed most egregiously from the truth. Huygens alone seems to have attended to this principle; for in the year 1590 he published a treatise on gravity, in which he gave an account of some experiments tending to prove that the track of all projectiles, moving with very swift motions, was widely different from that of a parabola. The rest of the learned generally acquiesced in the justness and sufficiency of Galileo's doctrine. Nor was any farther notice taken of these errors till the year 1716, at which time Mr. Resson, a French officer of artillery, of great merit and experience, gave in a memoir to the Royal Academy, importing that, 'although it was agreed that theory joined with practice did constitute the perfection of every art, yet experience had taught him that theory was of very little service in the use of mortars: that the works of M. Blondell had justly enough described the several parabolic lines according to the different degrees of the elevation of the piece: but that practice had convinced him there was no theory in the effect of gunpowder; for having endeavoured, with the greatest precision, to point a mortar according to these calculations, he had never been able to establish any solid foundation upon them.' One instance only occurs, in which D. Bernouill applies the doctrine of Newton to the motions of projectiles, in the Com. Acad. Petrop. tom. ii. p. 338, &c. Besides which nothing farther was done in this business till the time of Robins, who published a treatise in 1742, intitled New Principles of Gunnery, in which he treated particularly not only of the resistance of the atmosphere, but also of the force of gunpowder, the nature and effects of different guns, and almost every thing else relating to the flight of military projectiles; and indeed he carried the theory of gunnery nearly to its utmost perfection.

The first thing considered by Mr. Robins, and which is indeed the foundation of all other particulars relating to gunnery, is the explosive force of gunpowder. M. de la Hire, in his History of the Academy of Sciences for the year 1702, supposed that this force may be owing to the in-

creased elasticity of the air contained in and between the grains, in consequence of the heat and fire produced at the time of the explosion: a cause not adequate to the 200th part of the effect. On the other hand, Mr. Robins determined, by irrefragable experiments, that this force was owing to an elastic fluid similar to our atmosphere, existing in the powder in an extremely condensed state, which being suddenly freed from the powder, by the combustion, expanded with an amazing force, and violently impelled the bullet, or whatever might oppose its expansion.

The intensity of this force of exploded gunpowder Mr. Robins ascertained in different ways, after the example of Mr. Hawkesbee, related in the Philosophical Transactions, No. 295, and in his Physico-Mechanical Experiments, p. 81. One of these is by firing the powder in the air thus:—A small quantity of the powder is placed in the upper part of a glass tube, and the lower part of the tube is immersed in water, the water being made to rise so near the top that only a small portion of air is left in that part where the powder is placed; then in this situation, the communication between the upper part of the tube and the external air being closed, the powder is fired by means of a burning glass, or otherwise; the water descends upon the explosion, and stands lower in the tube than before, by a space proportioned to the quantity of powder fired. Another way was by firing the powder in vacuo, viz. in an exhausted receiver, by dropping the grains of powder upon a hot iron included in the receiver. By this means a permanent elastic fluid was generated from the fired powder, and the quantity of it was always in proportion to the quantity of powder that was used, as was found by the proportional sinking of the mercurial gauge annexed to the air-pump. The result of these experiments was, that the weight of the elastic air thus generated was equal to three-tenths of the compound mass of the gunpowder which yielded it, and that its bulk when cold, and expanded to the rarity of the common air, was about 240 times the bulk of the powder; and consequently in the same proportion would such fluid at first, if it were cold, exceed the force or elasticity of the atmosphere. But as Mr. Robins found, by another ingenious experiment, that air heated to the extreme degree of the white heat of iron has its elasticity quadrupled, or is four times as strong, he thence inferred that the force of the elastic air generated as above, at the moment of the explosion, is at least four times 240, or 960, or, in round numbers, about 1000 times as strong as the elasticity or pressure of the atmosphere on the same space.

Having thus determined the force of the gunpowder, or intensity of the agent by which the projectile is to be urged, Mr. Robins proceeded to determine the effects it will produce, or the velocity with which it will impel a shot of a given weight from a piece of ordnance of given dimensions; which is a problem strictly limited and perfectly soluble by mathematical rules, and is in general this:—Given the first force, and the law of its variation, to determine the velocity with which it will impel a given body, in passing

through a given space, which is the length of the bore of the gun. In the solution of this problem Mr. Robins assumes these two postulates, viz. 1. That the action of the powder on the bullet ceases as soon as the bullet is out of the piece; and 2d. That all the powder of the charge is fired and converted into elastic fluid before the bullet is sensibly moved from its place: assumptions which for good reasons are found to be in many cases very near the truth. It is to be noted also, that the law by which the force of the elastic fluid varies is this, viz. that its intensity is directly as its density, or reciprocally proportional to the space it occupies, being so much the stronger as the space is less: a principle well known, and common to all elastic fluids. Upon these principles, then, Mr. Robins resolves this problem, by means of the thirty-ninth proposition of Newton's Principia, in a direct way, and the result is equivalent to this theorem, when the quantities are expressed by algebraic symbols; viz. the velocity of the ball.

$$v = 27130 \sqrt{\frac{10a}{cd} \times \log. \frac{b}{a}}$$

$$\text{or} = 100 \sqrt{\frac{223 ad^2}{w} \times \log. \frac{b}{a}};$$

where  $v$  is the velocity of the ball,  $a$  the length of the charge of powder,  $b$  the whole length of the bore,  $c$  the specific gravity of the ball, or weight of a cubic foot of the same matter in ounces,  $d$  the diameter of the bore,  $w$  the weight of the ball in ounces.

For example, suppose  $a = 2\frac{1}{2}$  inches,  $b = 45$  inches,  $c = 11345$  ozs. for a ball of lead, and

$$d = \frac{1}{4} \text{ inch; then } v = 27130 \sqrt{\frac{7}{2269} \times \log. \frac{120}{7}}$$

= 1674 feet per second, the velocity of the ball.

Or, if the weight of the bullet be  $w = 1\frac{1}{8}$  ozs. =  $\frac{19}{8}$  ozs. Then  $v = 100$

$$\sqrt{\frac{1115 \times 189}{29 \times 32} \times \log. \frac{120}{7}} = 1674 \text{ feet, as before.}$$

'Having in this proposition,' says Mr. Robins, 'shown how the velocity which any bullet acquires from the force of powder may be computed upon the principles of the theory laid down in the preceding propositions, we shall next show that the actual velocities with which bullets of different magnitudes are impelled from different pieces, with different quantities of powder, are really the same with the velocities assigned by these computations, and consequently that this theory of the force of powder, here delivered, does unquestionably ascertain the true action and modification of this enormous power.'

'But, in order to compare the velocities communicated to bullets by the explosion with the velocities resulting from the theory by computation, it is necessary that the actual velocities with which bullets move should be capable of being discovered, which yet is impossible to be done by my methods hitherto made public. The only means hitherto practised by others for that purpose have been either by observing the time of

the flight of the shot through a given space, or by measuring the range of the shot at a given elevation, and thence computing on the parabolic hypothesis what velocity would produce this range. The first method labors under this insurmountable difficulty, that the velocities of these bodies are often so swift, and consequently the time observed is so short, that an imperceptible error in that time may occasion an error in the velocity thus found of 200, 300, 400, 500, or 600 feet in a second. The other method is so fallacious, by reason of the resistance of the air (to which inequality the first is also liable), that the velocities thus assigned may not be perhaps the tenth part of the actual velocities sought.

'To remedy then these inconveniences, I have invented a new method of finding the real velocities of bullets of all kinds; and this to such a degree of exactness (which may be augmented too at pleasure) that in a bullet moving with the velocity of 1700 feet in a second, the error in the estimation of it need never amount to its 500th part; and this without any extraordinary nicety in the construction of the machine.'

Mr. Robins then gives an account of the machine by which he measures the velocities of the balls, which machine is simply this: viz. a pendulous block of wood suspended freely by a horizontal axis, against which block are to be fired the balls whose velocities are to be determined.

'This instrument thus fitted, if the weight of the pendulum be known, and likewise the respective distances of its centre of gravity and of its centre of oscillation from its axis of suspension, it will thence be known what motion will be communicated to this pendulum by the percussion of a body of a known weight moving with a known degree of celerity, and striking it in a given point; that is, if the pendulum be supposed at rest before the percussion it will be known what vibration it ought to make in consequence of such a determined blow; and, on the contrary, if the pendulum, being at rest, is struck by a body of a known weight, and the vibration which the pendulum makes after the blow is known, the velocity of the striking body may thence be determined.'

'Hence then, if a bullet of a known weight strikes the pendulum, and the vibration which the pendulum makes in consequence of the stroke be ascertained, the velocity with which the ball moved is thence to be known.'

Our author then explains his method of computing velocities from experiments with this machine; which method is rather troublesome and perplexed, as well as the rules of Euler and Antoni, who followed him in this business; but a much plainer rule is given in Hutton's Tracts, vol. i. p. 119, where such experiments are explained at full length, and this rule is expressed by either of the two following formulas,

$$v = 56727cg \times \frac{p+b}{bir} = 61458cg \times \frac{p+b}{birn}$$

the velocity; where  $v$  denotes the velocity of the ball when it strikes the pendulum,  $p$  the weight of the pendulum,  $b$  the weight of the ball,  $c$  the chord of the arc described by the vibration to the

M

radius,  $r$   $g$  the distance below the axis of motion to the centre of gravity,  $o$  the distance to the centre of oscillation,  $i$  the distance to the point of impact, and  $n$  the number of oscillations the pendulum will perform in one minute, when made to oscillate in small arcs. The latter of these two theorems is much the easiest, both because it is free of radicals, and because the value of the radical  $\sqrt{o}$ , in the former, is to be first computed from the number  $n$ , or number of oscillations the pendulum is observed to make. With such machines Mr. Robins made a great number of experiments with musket barrels of different lengths, with balls of various weights, and with different charges or quantities of powder. He has set down the results of sixty-one of these experiments, which nearly agree with the corresponding velocities as computed by his theory of the force of powder, and which therefore establish that theory on a sure foundation.

From these experiments, as well as from the preceding theory, many important conclusions were deduced by Mr. Robins; and indeed, by means of these, it is obvious that every thing may be determined relative both to the true theory of projectiles, and to the practice of artillery; for, by firing a piece of ordnance charged in a similar manner against such a ballistic pendulum from different distances, the velocity lost by passing through such spaces of air will be found, and consequently the resistance of the air, the only circumstance that was wanting to complete the theory of gunnery or military projectiles; and of this kind Dr. Hutton made a great number of experiments with cannon balls, and has thereby obtained the whole series of resistances to such a ball when moving with every degree of velocity, from 0 up to 2000 feet per second of time. In the structure of artillery they may likewise be of the greatest use; for hence may be determined the best lengths of guns; the proportions of the shot and powder to the several lengths; the thickness of a piece, so as it may be able to confine, without bursting, any given charge of powder; as also the effect of wads, chambers, placing of the vent, ramming the powder, &c. For the many other curious circumstances relating to this subject, and the various other improvements in the theory and practise of gunnery made by Mr. Robins, consult the first volume of his Tracts, collected and published by Dr. Wilson in the year 1761, where ample information may be found.

In the year 1755, says Dr Hutton, in conjunction with several able officers of the royal artillery and other ingenious gentlemen, I undertook a course of experiments with the ballistic pendulum, in which we ventured to extend the machinery to cannon shot of one, two, and three pounds weight. An account of these experiments was published in the Philosophical Transactions for 1778; and for which the Royal Society honored me with the prize of the gold medal. These were the only experiments that I know of which had been made with cannon balls for this purpose, although the conclusions to be deduced from such are of the greatest importance to those parts of natural philosophy which are dependent on the effects of fired gunpowder: nor do I know of any other practical method of ascertaining the

initial velocities with any tolerable degree of truth. The knowledge of this velocity is of the utmost consequence in gunnery; by means of it, together with the law of the resistance of the medium, every thing is determinable relative to that business; for, besides its being an excellent method of trying the strength of different sorts of powder, it gives us the law relative to the different quantities of powder, to the different weights of shot, and to the different lengths and sizes of guns. Besides these, there does not seem to be any thing wanting to answer any enquiry that can be made concerning the flight and ranges of shots except the effects arising from the resistance of the medium. In these experiments the weights of the pendulums employed were from 300 to nearly 600 pounds. In that paper is described the method of constructing the machines, of finding the centres of gravity and oscillation of the pendulum, and of making the experiments, which are all set down in the form of a journal, with all the minute and concomitant circumstances; also the investigation of the new and easy rule set down just above, for computing the velocity of the ball from the experiments. The charges of powder were varied from two to eight ounces, and the shot from one to nearly three pounds. And from the whole were clearly deduced the inferences we have already given.

In the year 1786 was published the first volume of Dr. Hutton's Tracts, in which is detailed, at great length, another very extensive course of experiments which were carried on at Woolwich in the years 1783, 1784, and 1785, by order of the duke of Richmond, master general of the ordnance. The objects of this course we have also enumerated in the theoretic part of this treatise.

These objects were obtained in a very perfect and accurate manner; excepting only the article of ranges, which were not quite so regular and uniform as might be wished. The balls too were most of them of one pound weight; but the powder was increased from one ounce up till the bore was quite full, and the pendulum was from 600 to 800 lbs. weight. The conclusions from the whole were as follow:—

1. That the former law, between the charge and velocity of ball, is again confirmed, viz. that the velocity is directly as the square root of the weight of powder, as far as to about the charge of eight ounces: and so it would continue for all charges, were the guns of an indefinite length. But as the length of the charge is increased, and bears a more considerable proportion to the length of the bore, the velocity falls the more short of that proportion.

2. That the velocity of the ball increases with the charge to a certain point, which is peculiar to each gun, where it is greatest; and that, by farther increasing the charge, the velocity gradually diminishes till the bore is quite full of powder. That this charge for the greatest velocity is greater as the gun is longer, but not greater however in so high a proportion as the length of the gun is; so that the part of the bore filled with powder bears a less proportion to the whole in the long guns, than it does in the short ones;

the part of the whole which is filled being indeed nearly in the reciprocal subduplicate ratio of the length of the empty part. And the other circumstances are as in this table.

TABLE of Charges producing the greatest Velocity.

Gun num.	Length of the bore.	Length filled.	Part of the whole.	Weight of the powder
	inches.	inches.		oz.
1	28·2	8·2	$\frac{3}{10}$	12
2	38·1	9·5	$\frac{1}{10}$	14
3	57·4	10·7	$\frac{1}{10}$	16
4	79·9	12·1	$\frac{1}{10}$	18

'3. It appears that the velocity continually increases as the gun is longer, though the increase in velocity is but very small in respect of the increase in length, the velocities being in a ratio somewhat less than that of the square roots of the length of the bore, but somewhat greater than that of the cube roots of the length, and is indeed nearly in the middle ratio between the two.

'4. The range increases in a much less ratio than the velocity, and indeed is nearly as the square root of the velocity, the gun and elevation being the same. And, when this is compared with the property of the velocity and length of run in the foregoing paragraph, we perceive that very little is gained in the range by a great increase in the length of the gun, the charge being the same. And indeed the range is nearly as the fifth root of the length of the bore, which is so small an increase as to amount only to about one-seventh part more range for a double length of gun.

'5. It also appears that the time of the ball's flight is nearly as the range; the gun and elevation being the same.

'6. It appears that there is no sensible difference caused in the velocity or range, by varying the weight of the gun, nor by the use of wads, nor by different degrees of ramming, nor by firing the charge of powder in different parts of it.

'7. But a great difference in the velocity arises from a small degree of windage. Indeed with the small established windage only, namely, about one-twentieth of the calibre, no less than between one-third and one-fourth of the powder escapes and is lost. And, as the balls are often smaller than that size, it frequently happens that half the powder is lost by unnecessary windage.

'8. It appears that the resisting force of wood to balls fired into it is not constant. And that the depths penetrated by different velocities or charges are nearly as the logarithms of the charges; instead of being as the charges themselves, or, which is the same thing, as the square of the velocity.

'9. These and most other experiments show that balls are greatly deflected from the direction they are projected in; and that so much as 300 or 400 yards in a range of a mile, or almost one-fourth of the range, which is nearly a deflection of an angle of 15°.

'10. Finally, these experiments furnish us with the following concomitant data, to a tolerable degree of accuracy, namely, the dimensions and

elevation of the gun, the weight and dimensions of the powder and shot, with the range and time of flight, and the first velocity of the ball. From which it is to be hoped that the measure of the resistance of the air to projectiles may be determined, and thereby lay the foundation for a true and practical system of gunnery, which may be as well useful in service as in theory.'

'Since the publication of those Tracts,' says Dr Hutton, 'we have prosecuted the experiments still farther from year to year, gradually extending our aim to more objects, and enlarging the guns and machinery, till we have arrived at experiments with the six-pounder guns, and pendulums of 1800 lbs. weight. One of the new objects of enquiry was the resistance the atmosphere makes to military projectiles; to obtain which the guns have been placed at many different distances from the pendulum, against which they are fired, to get the velocity lost in passing through those spaces of air; by which, and the use of the whirling machine, described near the end of the first volume of Robins's Tracts, for the slower motions, I have investigated the resistance of the air to given balls moving with all degrees of velocity from 0 up to 2000 feet per second; as well as the resistance for many degrees of velocity to planes and figures of other shapes, and inclined to their path in all varieties of angles; from which I have deduced general laws and formulas for all such motions.

'Mr. Robins made also similar experiments on the resistance of the air, but being only with musket bullets, on account of their smallness and of their change of figure by the explosion of the powder, I find they are very inaccurate, and considerably different from those above mentioned, which were accurately made with pretty considerable cannon balls of iron. For this reason we may omit here the rules and theory deduced from them by Mr. Robins, till others more correct shall have been established. All these experiments indeed agree in evincing the very enormous resistance the air makes to the swift motions of military projectiles, amounting in some cases to twenty or thirty times the weight of the ball itself; on which account the common rules for projectiles deduced from the parabolic theory are of little or no use in real practice; for from these experiments it is clearly proved that the track described by the flight even of the heaviest shot is neither a parabola, nor yet approaching any thing near it, except when they are projected with very small velocities; inso-much that some balls, which in the air range only to the distance of one mile, would in vacuo, when projected with the same velocity, range above ten or twenty times as far.'

Mr. Benjamin Thompson (the late count Rumford) instituted a very considerable course of experiments of the same kind as those of Mr. Robins, with musket barrels, which was published in the Philosophical Transactions, vol. 71, for the year 1781. In these experiments the conclusions of Mr. Robins are generally confirmed, and several other curious circumstances in this business are remarked by Mr. Thompson. This gentleman also pursues a hint thrown out by Mr. Robins, relative to the determining the velocity of

a ball from the recoil of the pendulous gun itself. Mr. Robins, in the eleventh proposition, remarks, that the effect of the exploded powder upon the recoil of a gun is the same whether the gun is charged with or without a ball; and that the chord or velocity of recoil with the powder alone, being subtracted from that of the recoil when charged with both powder and ball, leaves the velocity which is due to the ball alone. Thence Mr. Thompson observes that the inference is obvious, viz. that the momentum thus communicated to the gun by the ball alone, being equal to the momentum of the ball, this becomes known; and therefore, being divided by the known weight of the ball, the quotient will be its velocity. Mr. Thompson sets a great value on this new rule, the velocities by means of which he found to agree nearly with several of those deduced from the motion of the pendulum; and in the other cases, in which they differed greatly from these, he very inconsistently supposes that these latter ones are erroneous. In the experiments, however, contained in Dr. Hutton's Tracts, a great multitude of those cases are compared together, and the inaccuracy of that new rule is fully proved.

Having in the ninth proposition compared together a number of computed and experimented velocities of balls to verify his theory; Mr. Robins, in the tenth proposition, assigns the changes in the force of powder, which arise from the different state of the atmosphere, as to heat and moisture, both which he finds have some effect on it, but especially the latter. In the eleventh proposition he investigates the velocity which the flame of gunpowder acquires by expanding itself, supposing it fired in a given piece of artillery, without either a bullet or any other body before it. This velocity he finds is upwards of 7000 feet per second. But the celebrated Euler, in his commentary on this part of Mr. Robins's book, thinks it may be still much greater, and in this proposition too it is that Mr. Robins declares his opinion above alluded to, viz. that the effect of the powder upon the recoil of the gun is the same in all cases whether fired with a ball or without one. In the twelfth proposition he ascertains the manner in which the flame of powder impels a ball which is laid at a considerable distance from the charge; showing here that the sudden accumulation and density of the fluid against the ball is the reason that the barrel is so often burst in those cases. In the thirteenth proposition he enumerates the various kinds of powder, and describes the properest methods of examining its goodness. He here shows that the best proportion of the ingredients is when the saltpetre is three-fourths of the whole compound mass of the powder, and the sulphur and charcoal the other one-fourth between them, in equal quantities. In this proposition Mr. Robins takes occasion to remark upon the use of *eprouvettes*, or methods of trying powder; condemning the practice of the English in using what is called the vertical *eprouvette*; as well as that of the French, in using a small mortar with a very large ball, and a small charge of powder, and instead of these he strongly recommends the use of his ballistic pendulum for its great accuracy. But for still more despatch, he says, he should use another method, which however he

reserves to himself without giving any particular description of it.

The other, or second chapter of Mr. Robins's work, in eight propositions, treats 'of the resistance of the air, and of the track described by the flight of shot and shells.' And of these, the first proposition describes the general principles of the resistance of fluids to solid bodies moving in them. Here Mr. Robins discriminates between continued and compressed fluids, which immediately rush into the space quitted by a body in them, and whose parts yield to the impulse of the body without condensing and accumulating before it; and such fluids as are imperfectly compressed, rushing into a void space, with a limited velocity, as in the case of our atmosphere, which condenses more and more before the ball as this moves quicker, and also presses the less behind it, by following it always with only a given velocity: hence it happens that the former fluid will resist moving bodies in proportion to the square of the velocity, while the latter resists in a higher proportion. The second proposition is 'to determine the resistance of the air to projectiles by experiments.' One of the methods for this purpose is by the ballistic pendulum, placing the gun at different distances from it, by which he finds the velocity lost in passing through certain spaces of air, and consequently the force of resistance to such velocities as the body moves with in the several parts of its path. And another way was by firing balls with a known given velocity, over a large piece of water, in which the fall and plunge of the ball could be seen, and consequently the space it passed over in a given time. By these means Mr. Robins determined the resistance of the air to several different velocities, all which showed that there was a gradual increase of the resistance, over the law of the square of the velocity, as the body moved quicker. In the remaining propositions of this chapter he proceeds a little farther in this subject of the resistance of the air; in which he lays down a rule for the proportion of the resistance between two assigned velocities; and he shows that when a twenty-four pound ball, fired with its full charge of powder, first issues from the piece, the resistance it meets with from the air is more than twenty times its weight. He farther shows that the track described by the flight of shot or shells is neither a parabola, nor nearly a parabola, unless they are projected with small velocities; and that 'bullets in their flight are not only depressed beneath their original direction, by the action of gravity, but are also frequently driven to the right or left of that direction by the action of some other force' and, in the eighth or last proposition, he pretends to show that the depths of penetration of balls into firm substances are as the squares of the velocities. But this is a mistake; for neither does it appear that his trials were sufficiently numerous or various, nor were his small leaden balls fit for this purpose; and it has appeared, from a number of trials with iron cannon balls, that the penetrations are in a much lower proportion, and that the resisting force of wood is not uniform. See Dr. Hutton's Tracts.

In the small tracts appended to the principles, in this volume, Mr. Robins prosecutes the sub-

ject of the resistance of the air much farther, and lays down rules for computing ranges made in the air. But these must be far from accurate, as they are founded on the two following principles, which are known, from numerous experiments, to be erroneous: viz. 1st, 'that till the velocity of the projectile surpasses that of 1100 feet in a second, the resistance may be esteemed to be in the duplicate proportion of the velocity. 2d, That if the velocity be greater than that of 1100 or 1200 feet in a second, then the absolute quantity of that resistance in these greater velocities will be near three times as great as it should be by a comparison with the smaller velocities.' For instead of leaping at once from the law of the square of the velocities, and ever after being about three times as much, experiments prove that the increase of the resistance above the law of the square of the velocity takes place at first in the smallest motions, and increases gradually more and more, to a certain point, but never rises so high as to be three times that quantity, after which it decreases again. To render this evident, Dr. Hutton has inserted the following table of the actual quantities of resistances, which are deduced from accurate experiments, and which show also the nature of the law of the variations by means of the columns of differences annexed, reserving the detail of the experiments themselves to another occasion. These resistances are, upon a ball of 19.65 inches in diameter, in avoirdupois ounces, and are for all velocities from 0 up to that of 2000 feet per second of time.

The quantity of the resistance of the air to a ball of 1.965 inches in diameter.

Veloc. in feet.	Resist. in ounces.	1st. Differences.	2d. Differences.
0	0.000		
5	0.006		
10	0.025		
15	0.054		
20	0.100		
25	0.155		
30	0.23		
40	0.42		
50	0.67		
100	2½	8½	5½
200	11	14	6
300	25	20	7
400	45	27	8
500	72	35	9
600	107	44	10
700	151	54	12
800	205	66	13
900	271	79	13
1000	350	92	12
1100	442	104	11
1200	546	115	9
1300	661	124	7
1400	785	131	4
1500	916	135	0
1600	1051	135	2
1700	1186	133	5
1800	1319	128	6
1900	1447	122	
2000	1569		

If the terms of any arithmetical series be squared, the second differences will be equal: hence this table proves the truth of the former part of Dr. Hutton's assertion. The additional tracts of Mr. Robins, in the latter part of this volume, which contain many useful and important matters, are numbered and titled as follows, viz. Number 1, 'Of the resistance of the air. Number 2, Of the resistance of the air; together with the method of computing the motions of bodies projected in that medium. Number 3, An Account of the experiments relating to the resistance of the air; exhibited at different times before the Royal Society, in the year 1746. Number 4, Of the force of fired gunpowder, together with the computation of the velocities thereby communicated to military projectiles. Number 5, A comparison of the experimental ranges of cannon and mortars, with the theory contained in the preceding papers. Practical maxims relating to the effects and management of artillery, and the flight of shells and shot. A proposal for increasing the strength of the British navy, by changing all the guns, from the eighteen-pounders downwards, into others of equal weight, but of a greater bore.' With several letters, and other papers, 'On pointing, or the directing of the cannon to strike distant objects; Of the nature and advantage of rifled barrel pieces,' &c.

'I have,' continues Dr. Hutton, 'dwelt thus long on Mr. Robins's New Principles of Gunnery, because it is the first work that can be considered as attempting to establish a practical system of gunnery, and projectiles, on good experiments, on the force of gunpowder, on the resistance of the air, and on the effects of different pieces of artillery. Those experiments are not however sufficiently perfect, both on account of the smallness of the bullets, and for want of good ranges to form a proper theory upon. I have supplied some of the necessary desiderata for this purpose, viz. the resistance of the air to cannon balls moving with all degrees of velocity, and the velocities communicated by given charge of powder, to different balls, and from different pieces of artillery. But there are still wanting good experiments with different pieces of ordnance, giving the ranges and times of flight, with all varieties of charges, and at all different angles of elevation. A few, however, of those I have obtained, as in the following small table, which are derived from experiments made with a medium one-pounder gun, the iron ball being nearly two inches in diameter:—

Powder.	Elevation of gun.	Velocity of ball.	Range.	Time of flight.
oz.		feet.	feet.	~
2	15	860	4100	9
4	15	1230	5100	12
8	15	1640	6600	14½
12	15	1680	6700	15½
2	45	860	5100	21

Dr. Hutton's second set of experiments were made with four brass guns very nicely bored and cast on purpose, of different lengths, but regular in all other respects, viz. of weight and bore.

The lengths of the bores of the guns were,

No. 1, 15 calibres, length of bore 28·5 inches.

2, 20 calibres . . . 38·4

3, 30 calibres . . . 57·7

4, 40 calibres . . . 80·2

the calibre of each being  $2\frac{1}{3}$  inches, and the medium weight of the balls 16 oz. 13 dr.

The mediums of all the experimental velocities of the balls, with which they struck the pendulous block of wood, placed at the distance of thirty-two feet from the muzzle of the gun, for several charges of powder, were as in the following table,

TABLE OF INITIAL VELOCITIES.

Powder.	The guns.			
	No. 1.	No. 2.	No. 3	No. 4
oz.	780	835	920	970
2	1100	1180	1300	1370
4	1340	1445	1590	1680
6	1430	1580	1790	1940
8	1436	1640		
12	.	1660		
14	.	.	2000	
16	.	.	.	2200
18	.	.	.	

placed in the first column, for all the four guns, the numbers denoting so many feet per second. Whence in general it appears how the velocities

increase with the charges of powder for each gun, and also how they increase as the guns are longer, with the same charge, in every instance.

By increasing the quantity of the charges continually, for each gun, it was found that the velocities continued to increase till they arrived at a certain degree, different in each gun; after which they constantly decreased again, till the bore was quite filled with the charge. The charges of powder when the velocities arrived at their maximum or greatest state were various, as might be expected, according to the lengths of the guns; and the weight of powder, with the length it extended in the bore, and the fractional part of the bore it occupied, are shown in the following table, of the charges for the greatest effect:—

Gun No.	Length of the bore.	The charge		
		Weight. oz.	Length.	
			Inches.	Part of whole
1	28·5	12	8·2	$\frac{1}{10}$
2	38·4	14	9·5	$\frac{1}{8}$
3	57·7	16	10·7	$\frac{1}{6}$
4	80·2	18	12·1	$\frac{1}{5}$

Of the few experiments in this course made to obtain the ranges and times of flight, the mediums are exhibited in the following table:—

Guns.	Powder.	Balls.			Elevat. gun.	Time of flight.	Range.	First velocity.
		Weight.	Diam.					
	oz.	oz.	dr.	inch.	°	secs.	feet.	feet.
No. 2.	2	16	10	1·96	45	21·2	5109	863
ditto.	2	16	5	1·96	15	9·2	4130	868
ditto.	4	16	8	1·96	15	9·2	4660	1234
ditto.	8	16	12	1·96	15	14·4	6066	1644
ditto.	12	16	12	1·95	15	15·5	6700	1676
No. 3.	8	15	8	1·96	15	10·1	5610	1938

In this table are contained the following concomitant data, determined with a tolerable degree of precision; viz. the weight of the powder, the weight and diameter of the ball, the initial or projectile velocity, the angle of elevation of the gun, the time in seconds of the ball's flight through the air, and its range, or the distance where it fell on the horizontal plane. From which it is hoped that some aid may be derived towards ascertaining the resistance of the medium, and its effects on other elevations, &c., and so afford some means of obtaining easy rules for the cases of practical gunnery; though the completion of this enquiry, for want of time at present, must be referred to another work.

Another subject of enquiry, in the foregoing experiments, was, how far the balls would penetrate into solid blocks of elm wood, fired in the direction of the fibres. The following tablet shows the results of a few of the trials that were made with the gun No. 2, with the most frequent

charges of two, four, and eight ounces of powder; and the mediums of the penetrations, as placed in the last line, are found to be seven, fifteen, and twenty inches, with those charges. These penetrations are nearly as the numbers 2, 4, 6, or 1, 2, 3; but the charges of powder are as 2, 4, 8, or 1, 2, 4; so that the penetrations are proportional to the charges as far as to four ounces, but in a less ratio at three ounces; whereas, by the theory of penetrations, the depths ought to be proportional to the charges, or, which is the same thing, as the squares of the velocities. So that it seems the resisting force of the wood is not uniformly or constantly the same, but that it increases a little with the increased velocity of the ball. This may probably be occasioned by the greater quantity of fibres driven before the ball; which may thus increase the spring and resistance of the wood, and prevent the ball from penetrating so deep as it otherwise might do.

Penetrations of balls into solid elm wood.		
Powder 2	4	8 oz.
7	16·6	18·9
	13·5	21·2
		18·1
		20·8
		20·5
Means 7	15	20

The deductions and observations made on the former course are here corroborated respecting the velocities and weights of the balls, &c. The velocity of the ball, however, increases with the increase of the charge only to a certain point peculiar to each gun, beyond which increase of the charge, the velocity of the ball diminishes till the bore is full of powder. That is to say, the velocity increases with the length of the gun, but not in equal proportion. The part filled with powder bears a less proportion to the whole bore in the long guns than in the shorter ones; it is nearly in the inverse ratio of the square root of the empty part.

It appears that the velocity, with equal charges, always increases as the gun is longer; though the increase in velocity is but very small in comparison to the increase in length; the velocities being in a ratio somewhat less than that of the square roots of the length of the bore, but greater than that of the cube roots of the same, and is indeed nearly in the middle ratio between the two.

It appears, from the table of ranges, that the range increases in a much lower ratio than the velocity, the gun and elevation being the same. And, when this is compared with the proportion of the velocity and length of gun in the last pa-

graph, it is evident that we gain extremely little in the range by a great increase in the length of the gun, with the same charge of powder. In fact, the range is nearly as the fifth root of the length of the bore; which is so small an increase, as to amount only to about a seventh part more range for a double length of gun. From the same table it also appears that the time of the ball's flight is nearly as the range; the gun and elevation being the same.

It has been found, by these experiments, that no difference is caused in the velocity, or range, by varying the weight of the gun, nor by the use of wads, nor by different degrees of ramming, nor by firing the charge of powder in different parts of it. But that a very great difference in the velocity arises from a small degree in the windage; indeed with the usual established windage only, viz. about one-twentieth of the calibre, no less than between one-third and one-fourth of the powder escapes and is lost: and, as the balls are often smaller than the regulated size, it frequently happens that half the powder is lost by unnecessary windage.

It appears too that the resisting force of wood, to balls fired into it, is not constant: and that the depths penetrated by balls, with different velocities or charges, are nearly as the logarithms of the charges, instead of being as the charges themselves, or, which is the same thing, as the square of the velocity. Lastly, these and most other experiments show, that balls are greatly deflected from the direction in which they are projected; and that as much as 300 or 400 yards in a range of a mile, or almost one-fourth of the range.

A third series of experiments enabled this excellent mathematician to furnish the three following tables of resistances, for three different sizes of balls, and for velocities between 100 feet and 2000 feet per second of time.

TABLE I.					TABLE II.			TABLE III.		
Resistances to a ball of 1·965 inches diameter, and 16 oz. 13 dr. weight.					Resistances to a ball 2·78 inches diameter, and 3 lb. weight.			Resistances to a ball 3·55 inches diameter, and 6 lb. 1 oz. 8 dr. weight.		
Veloc.	Resistances.		1st. Dif.	2d. Dif.	Veloc.	Res.	Difs.	Veloc.	Res.	Difs.
feet.	lbs.	ozs.			feet.	lbs.		feet.	lbs.	
100	0·17	2½	8¼		900	35		1200	115	
200	0·69	11	14	5½	950	41	6	1250	124	9
300	1·56	25	20	6	1000	47	6	1300	133	9
400	2·81	45	27	7	1050	53	6	1350	142	9
500	4·50	72	35	8	1100	60	7	1400	152	10
600	6·69	107	44	9	1150	67	7	1450	162	10
700	9·44	151	54	10	1200	74	7	1500	172½	10½
800	12·81	205	66	12	1250	82	8	1550	184	11½
900	16·94	271	79	13	1300	91	9	1600	197	13
1000	21·88	350	92	13	1350	101	10	1650	211	14
1100	27·63	442	104	12	1400	112	11	1700	226	15
1200	34·13	546	115	11	1450	122½	10½	1750	242	16
1300	41·31	661	124	9	1500	132½	10	1800	259	17
1400	49·06	785	131	7	1550	141½	9			
1500	57·25	916	135	4	1600	150	8½			
1600	65·69	1051	135	0	1650	158	8			
1700	74·13	1186	133	—2	1700	165	7			
1800	82·44	1319	128	—5	1750	171	6			
1900	90·44	1447	122	—6	1800	176	5			
2000	98·06	1569								



It is remarkable that, notwithstanding the decisive manner in which Dr. Hutton recommended the diminution of windage, it should not have been adopted in practice till very lately; and that in consequence principally of the representations of Sir Howard Douglas. This able officer, in part second of his *Naval Gunnery*, points out the extraordinary anomalies in the previously received system of windage, and expatiates with great good sense upon their prejudicial effects. He satisfactorily refutes the popular objections to any change, and then proceeds thus:—'The preceding remarks on windage having been brought under the consideration of the master general of the ordnance in 1817, his lordship referred the paper to the consideration of a select committee of artillery officers, who stated in their report 'that they were very desirous that experiments should be made with a view to ascertain to what extent the benefits which I had anticipated could be realised.' The committee, therefore, proposed to the master general to be permitted to make a course of experiments on this subject, commencing with field-artillery, and for that purpose recommended that a proportion of shot of various increased magnitudes should be provided. These measures having been approved, a course of experiments was instituted accordingly, 'founded upon the suggestions communicated by' me.

'Having first adopted an opinion (asserted in my *Observations*, articles 49, 53), that the present mode of apportioning a part of the calibre is not so distinct and advantageous as a fixed quantum expressed in parts of inches for all natures (of ordnance), the committee proceeded to determine what that quantum should be. After repeated trials with a six-pounder, a nine-pounder, and a twelve-pounder, at 300, 600, and 1200 yards, it was proved, 'that with charges of powder one-sixth less than usual, the larger shot and smaller windage produced rather the longest range.' 'Recourse was also had to the ballistic pendulum, to discover the proportional excess of momentum of the larger balls over the smaller; and the result, after a very satisfactory course of experiments, assisted by the scientific research and well known mathematical abilities of Dr. Gregory of the Royal Military Academy, corroborated the trials by ranges, leaving no doubt

of their accuracy. In consequence of these trials the committee fixed the quantity of windage for field-guns at one-tenth of an inch; the same which I had suggested.

'Now it is clear that this improvement may either be applied to save one-sixth part of the quantity of powder provided for field-service, without diminishing the power of range, and consequently to economise, without detriment, the means of transport for ammunition: or the alteration may be applied to produce longer ranges, if this be preferred to the economical consideration. This preference has very properly been given, and the established charges adhered to accordingly. A great collateral advantage has followed from this correction of windage. It was at first apprehended that the increased effects arising from the additional weight of shot and diminished windage would injure brass guns; but it is quite the reverse. With the reduced quantum of windage guns are much less injured, and will last much longer than formerly; and this has been so well ascertained, that in consequence of this correction, it is now proposed to abandon the wooden bottoms to which shot were fixed for the purpose of saving the cylinder, substituting for them the paper cap taken off the end of the cartridge. This being put over the ball is quite sufficient to keep it from rolling or shifting, whilst, by supporting or fixing it thus, the centre of the ball coincides with the axis of the cylinder, and the space for windage is reduced to a complete annulus, which admits of the percussion from the charge being equally received, and which prevents, or very much reduces, that injury or indentation which the cylinder receives when the ball touches it on the lower part only.'—*Naval Gunnery*, p. 82.

An abridged account of the experiments with the ballistic pendulum, to which Sir Howard Douglas refers, is given in *Annales de Chimie et de Physique*, tome ix. p. 289, &c. We shall transcribe the results of one day, May 19th, 1818.

The day was dry, but cloudy; the thermometer stood at 13·3° centigrade (56° Fahrenheit), the barometer at 29·9° inches. The pendulum weighed 7008 pounds avoirdupois. The gun was a twelve-pounder; its weight 2025 pounds; its length 74·25 English inches; its calibre 4·62 inches.

Number of the Experiments.	Weight of the Ball.	Diameter of the Ball.	Windage.	Charge of Powder.	Velocities obtained.
	lbs. oz. drs.	inches.	inch.	lbs. oz. drs.	feet.
1	12 12 0	4·545	0·075	3 5 6	1548
2	12 12 7	4·54	0·080	3 5 6	1537
3	12 11 0	4·545	0·075	3 5 6	1568
4	12 10 1	4·54	0·080	3 5 6	1507
5	11 11 8	4·42	0·200	4 0 0	1572
6	11 10 4	4·418	0·202	4 0 0	1537
7	11 12 1	4·418	0·202	4 0 0	1563
8	11 12 1	4·418	0·202	4 0 0	1529

Here it is evident that the velocity corresponding to a windage of 0·75, or  $\frac{3}{4}$ ths of an inch, is at a mean 1568 feet, rather exceeding 1550 feet, obtained when the windage was  $\cdot 20$ , or  $\frac{1}{5}$ ths;

though in the former case the charge was less by  $\frac{1}{10}$ th part than the latter.

Assuming the correctness of the results, as tabulated above, we are by no means inclined to

agree with Sir Howard, however, in recommending an adherence to the established charges, viz. of a third of the weight of the ball, after the new rate of windage is completely adopted. Supposing that, *cæteris paribus*, the initial velocity varies as the square root of the charge, a four-pound charge with the new windage would propel a twelve-pound ball with an initial velocity of about 1720 feet, a velocity which would be very effective indeed if the ball were moving through a non-resisting medium, but which experiences a most rapid retardation as the projectile passes through the air. The experiments of Dr. Hutton prove, not only that the resistance of the air becomes very enormous when the velocities exceed 1300 feet, but that the law of the resistance no longer accords nearly with the square of the velocity, but, to be correctly exhibited, requires a higher exponent. The reason is very evident. Atmospheric air rushes into a vacuum with a velocity of about 1346 feet per second, and it manifestly cannot make way for a ball moving with a greater velocity than this without being condensed before it. In such cases, the air thus condensed in front of the ball, opposes its motion not only by a simple resistance, but by a force of elasticity proportional to the compression, and therefore rapidly increasing as the velocity of the projectile exceeds 1346 feet. This repulsion soon reduces the higher velocities of 1600 or 1700 feet to the limit of from 1350 to 1400, and consequently renders them of scarcely any use in either increasing the horizontal range, or the effective impetus of the ball, except at comparatively small distances from the mouth of the piece. This accords with the experience of our artillery officers when employed in Spain; they found that balls-fired with velocities of 1600 feet had scarcely any advantage over those propelled with velocities of 1400 in the destruction of distant objects.

Theorists have long known that the elastic force exerted by the air against small bodies, moving with considerable velocities, may become so great in proportion to the weight as not merely to destroy the motion communicated, but even to repel the bodies; and this, indeed, is frequently experienced when small shot are thrown from a musket by large charges of powder, the shot being driven back in the contrary direction to that in which they were propelled. The same thing of course does not precisely happen in the practice of artillery; but it is a fact strictly coincident with theory, that a smaller charge of powder, by giving the shot less initial velocity, will cause it to fly further than a greater charge, which would propel the ball with a velocity that exceeds a certain limit.

A military officer of some eminence, but defective, as we should conjecture, in mathematical knowledge, has recently proposed the use of short guns, especially in the service of the navy, strangely fancying that the loss of velocity and range, that would attend the shortening of the gun, would be more than compensated by some suggested peculiarities in the external configuration of the piece. This is utterly repugnant to correct theory, and we believe to correct practice &c. The question was put to the test in the

Woolwich experiments of 1817, and the result was uniformly and decidedly against the short guns. That additions to the length of the piece should occasion increased velocity of projection is obviously the joint effect of two causes. 1st, The expansive force of the inflamed gunpowder acts longer upon the ball in a long than in a short gun, and therefore communicates a greater velocity. 2dly, In short guns no small portion of the gun-powder is carried out of the muzzle without being at all inflamed. The lengths, however, must be limited by practical considerations, as well as by the theoretical ones deducible from our quotation a few pages back from Dr. Hutton.

Sir Howard Douglas, who has the happy faculty of confirming his theoretical positions by reference to historical facts, adduces some with a view to this question, which we make no apology for citing.—‘Viewing the matter purely as an artillery question, there is no doubt that preference should be given to long guns. As to its application to naval matters, I do not hesitate to recommend that a frigate which cannot carry eight feet twenty-four pounders, had better be fitted with long eighteen pounders, than with six feet or six feet and a half twenty-four pounders, or with any nature of carronade, exclusively. The very mortifying situation in which the gallant Sir James Yeo found himself in September, 1813, on Lake Ontario, shows the danger of the carronade system of armament. Sir James states, in his letter of the 12th of September, ‘the enemy’s fleet of eleven sail, having a partial wind, succeeded in getting within range of their long twenty-four and thirty-two pounders; and, having obtained the wind of us, I found it impossible to bring them to close action. We remained in this mortifying situation five hours, having only six guns in the fleet that would reach the enemy. Not a carronade was fired. At sun-set a breeze sprang up from the westward, when I manœuvred to oblige the enemy to meet us on equal terms. This, however, he carefully avoided.’

‘Captain Barclay states, in his letter of the 12th of September, 1813:—‘The other brig of the enemy, apparently destined to engage the Queen Charlotte, supported in like manner by two schooners, kept so far to windward as to render the Queen Charlotte’s twenty-four pounder carronades useless, whilst she and the Lady Prevost were exposed to a heavy and destructive fire from the Caledonian and four other schooners, armed with long and heavy guns.’

Sir Howard next describes the action of the *Phœbe* with the American frigate *Essex*, as confirming the theoretical view of the business; and adds:—‘This brilliant affair, together with the preceding facts, cannot fail to dictate the necessity of abandoning a principle of armament exposed to such perils, and to teach the importance of adapting the tactics of an operation to the comparative natures and powers of arms.’—*Naval Gunnery*, p. 116.

On the whole, we trust we shall not be accused of any unworthy feeling, if we remark that all, or nearly all, which is truly valuable in this department of research has been the produce of

Britain. We have no wish to depreciate the labors of Bernouilli, Euler, and others, of whom we have already spoken in terms of commendation; and upon whose genius and attainments we often reflect with pleasure. Yet had it not been for the practical turn given to the investigation by Robins, and so incessantly kept in mind, and so skilfully and elaborately carried out to its professional applications by Dr. Hutton, the principles of gunnery would at this moment have been little better than a collection of barren speculative rules, calculated to mislead, rather than direct, the intelligent engineer.

In the notice we have taken of Robins's experiments, we do not perceive that we have described his celebrated ballistic pendulum. It consists of a large block of wood, annexed to the end of an iron stem, strongly framed, and capable of oscillating freely upon a horizontal axis. This machine being at rest, a piece of ordnance is pointed directly towards the face of the block, at any assigned distance, as twenty, thirty, forty, sixty, &c., feet, and then fired; the ball discharged from the gun strikes and enters the block, communicating to it a velocity, which is to the velocity with which the ball was moving at the moment of impact as the weight of the ball to the sum of the weights of ball and pendulum. Referring this velocity to the centre of oscillation of the pendulum, it will rise through an appreciable arc of vibration till such velocity is extinguished. The measure of that arc will lead to the determination of the velocity, because it is evidently equal to the velocity which a body would acquire by falling freely through the versed sine of the arc shown by the experiment.

Robins's largest ballistic pendulum weighed only ninety-seven pounds; being employed to ascertain the velocities of balls weighing about an ounce each. The smallest pendulum constructed by Dr. Hutton weighed 600 pounds; and, as he pursued his experiments, the new pendulums were made successively larger and larger, till at last they reached the weight of about 2600 pounds. He also made several improvements in their construction, especially in their manner of suspension, and in that of measuring the semi-arc of vibration; employing this curious apparatus in ascertaining the velocities of balls varying in weight from one pound to six, and propelled with nearly all possible modifications of charge. It appears farther, from *Annales de Chimie et de Physique*, tome 5, that in recent experiments at Woolwich, conducted by Dr. Gregory and the select committee of artillery officers, a ballistic pendulum, weighing 7400 pounds, was employed in determining the velocities of six, twelve, eighteen, and twenty-four pounders.

*Of Rifled-barrelled Guns.*—The greatest irregularities in the motion of bullets are owing to the whirling motion on their axis, acquired by the friction against the sides of the piece. The best method hitherto known of preventing these is by the use of pieces with rifled barrels. These pieces have the insides of their cylinders cut with spiral channels, as a female screw, varying

from the common screws only in this, that its threads or rifles are less deflected, and approach more to a right line; it being usual for the threads with which the rifled barrel is indented to take little more than one turn in its whole length. The numbers of these threads are not determinate.

The usual method of charging these pieces is this:—The proper quantity of powder being put down, a leaden bullet not larger than the bore of the piece is forcibly driven home to the powder; and in its passage acquires the shape of the inside of the barrel, so that it becomes part of a male screw, exactly answering to the indents of the rifle. The rifled barrels made in Britain are often contrived to admit the charge and shot at the breech; and the ball acquires the same shape in its expulsion that is given to it by the more laborious operation of driving it in at the muzzle. From the whirling motion communicated by the rifles, it happens that, when the piece is fired, that indented zone of the bullet follows the sweep of the rifles, and thereby, besides its progressive motion, acquires a circular motion round the axis of the piece; which circular motion will be continued to the bullet after its separation from the piece; and thus a bullet discharged from a rifled barrel is constantly made to whirl round an axis which is coincident with the line of its flight. By this whirling on its axis, the aberration of the bullet, which proves so prejudicial to all operations in gunnery, is almost totally prevented: and accordingly such pieces are much more to be depended on, and will do execution at a much greater distance, than the other. But as it is in a manner impossible entirely to correct the aberrations arising from the resistance of the atmosphere, even the rifled barrelled pieces cannot be depended upon for more than one-half of their actual range at any considerable elevation. It becomes therefore a problem very difficult of solution, to know, even within a very considerable distance, how far a piece will carry its ball with any probability of hitting its mark, or doing any execution. The best rules hitherto laid down on this subject are those of Robins.

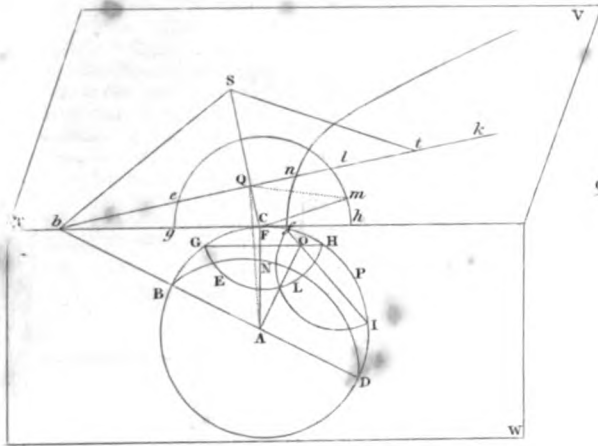
*Of Carronades.*—Mr. Gascoigne's improved gun, called a carronade, was, in June 1779, by the king in council instituted a standard navy-gun, and ten of them appointed to be added to each ship of war, from a first-rate to a sloop.

The carronade is mounted upon a carriage with a perfectly smooth bottom of strong plank, without trucks; instead of which there is fixed on the bottom of the carriage, perpendicular from the trunnions, a gudgeon of proper strength, with an iron washer and pin at the lower end. This gudgeon is let into a corresponding groove cut in a second carriage, called a slide-carriage; the washer supported by the pin overreaching the under edges of the groove. This slide carriage is made with a smooth upper surface, upon which the gun-carriage is moved, and by the gudgeon always kept in its right station to the port; the groove in the slide-carriage being of a sufficient length to allow the gun to recoil and be loaded within board. The slide-carriage, the groove included, is equally broad with the fore-

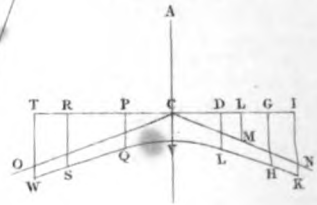


# PROJECTION OF THE SPHERE.

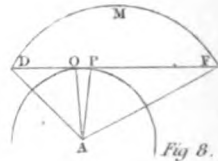
*Fig. 1*



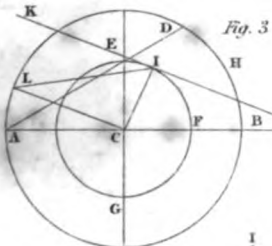
*Fig. 5*



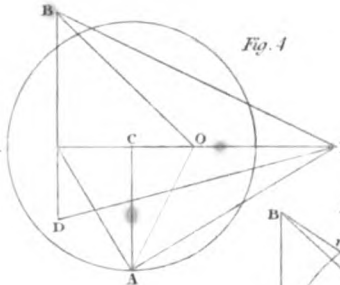
*Fig. 7*



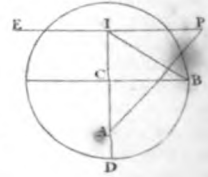
*Fig. 8.*



*Fig. 3*

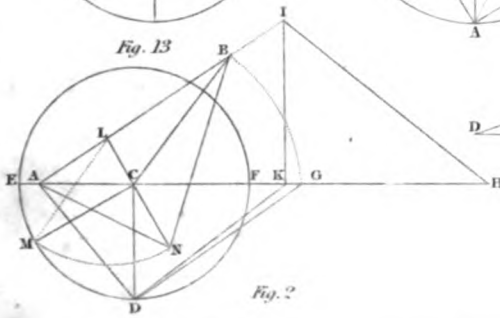


*Fig. 4*

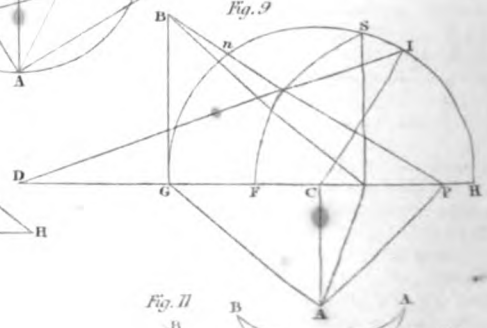


*Fig. 9*

*Fig. 13*



*Fig. 2*



*Fig. 11*

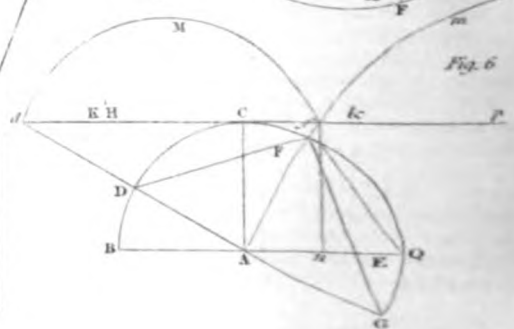
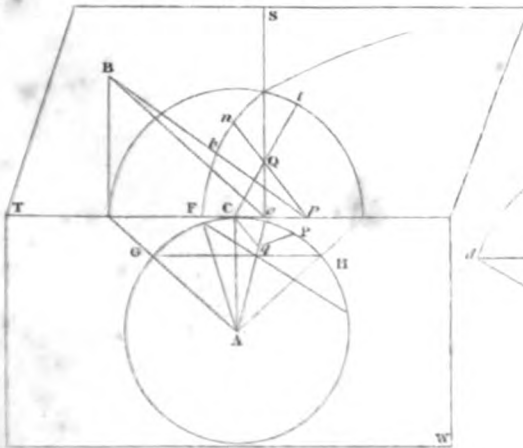


*Fig. 10*

*Fig. 12*



*Fig. 6*



part of the gun-carriage, and about four times the length; the fore part of the slide-carriage is fixed by hinge-bolts to the quick-work of the ship below the port, the end lying over the fill, close to the outside plank, and the groove reaching to the fore end; the gudgeon of the gun-carriage, and consequently the trunnions of the gun, are over the fill of the port when the gun is run out; and the port is made of such breadth, with its sides bevelled off within board, that the gun and carriage may range from bow to quarter. The slide-carriage is supported from the deck at the hinder end, by a wedge or step-stool; which being altered at pleasure, and the fore end turning upon the hinge-bolts, the carriage can be constantly kept upon an horizontal plane, for the more easy and quick working of the gun when the ship lies along. But see Sir Howard Douglas's remarks on this piece, already given.

*Of Rifled Ordnance.*—In 1774 Dr. Lind, and captain Alexander Blair of the sixty-ninth regiment of foot, invented a species of rifled field-

pieces. They are made of cast-iron; and are not bored like the common pieces, but have the rifles moulded on the core, after which they are cleaned out and finished with proper instruments. Guns of this construction, which are intended for the field, ought not to be made to carry a ball of above one or two pounds weight at most; a leaden bullet of that weight being sufficient to destroy either man or horse. A pound-gun, of this construction, of good metal, need not weigh above 100 lbs., nor its carriage above 100 lbs. more. It can therefore be easily transported from place to place, by a few men; and a couple of good horses may transport six of these guns and their carriages, if put into a cart. But this kind of ordnance has never been extensively used, we believe, in the British service. See our article ARTILLERY, for the latest official regulations for the proportion and disposition of the ammunition attached to the field pieces of our army: as also for the guns attached to the brigades of artillery. See also CANNON.

*The PROJECTION OF THE SPHERE* is a perspective representation of the circles on the surface of the globe; and is variously denominated, according to the different positions of the eye and plane of projection. There are three principal kinds of projection; the stereographic, the orthographic, and gnomonic. In the stereographic projection, the eye is supposed to be placed on the surface of the sphere; in the orthographic it is supposed to be at an infinite distance; and in the gnomonic projection the eye is placed at the centre of the sphere. Other kinds of projection are, the globular, Mercator's development, &c.

The chief application of the doctrine of these projections is to the constructing of maps and dials. In our article MAPS we have, therefore, entered at length into the principal projections; i. e. 1. By development; 2. The orthographic; 3. The stereographic; 4. The globular; and 5. Mercator's.

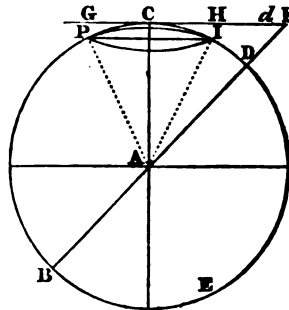
In that of DIALLING the *gnomonic* is involved. See that article. It may, however, be thus exhibited more formally.

The eye, in this projection, is in the centre of the sphere, and the plane of projection touches the sphere in a given point parallel to a given circle: the plane of projection will represent the plane of a dial, whose centre being the projected pole, the semi-axis of the sphere will be the stile or gnomon of the dial.

**PROP. I. THEOR. I.**—Every great circle is projected into a straight line perpendicular to the line of measures; and whose distance from the centre is equal to the cotangent of its inclination, or to the tangent of its nearest distance from the pole of the projection.

Let  $BAD$ , fig. 1, be the given circle, and let the circle  $CBED$  be perpendicular to  $BAD$ , and to the plane of projection: whose intersection  $CF$  with this last plane will be the line of measures. Now, since the circle  $CBED$  is perpendicular both to the given circle  $BAD$  and to the plane of projection, the common section of the two last planes produced will therefore be perpendicular to the plane of the circle  $CBE$

Fig. 1.



produced, and consequently to the line of measures: hence the given circle will be projected into that section; that is, into a straight line passing through  $d$ , perpendicular to  $Cd$ . Now  $Cd$  is the cotangent of the angle  $CdA$ , the inclination of the given circle, or the tangent of the arch  $CD$  to the radius  $AC$ .

**COROL. 1.** A great circle perpendicular to the plane of projection is projected into a straight line passing through the centre of projection; and any arch is projected into its correspondent tangent.

2. Any point, as  $D$ , or the pole of any circle, is projected into a point  $d$ , whose distance from the pole of projection is equal to the tangent of that distance.

3. If two great circles be perpendicular to each other, and one of them passes through the pole of projection, they will be projected into two straight lines perpendicular to each other.

4. Hence if a great circle be perpendicular to several other great circles, and its representation pass through the centre of projection; then all these circles will be represented by lines parallel to one another and perpendicular to the line of measures, for representation of that first circle.

**PROP. II. THEOR. II.** If two great circles intersect in the pole of projection, their representations will make an angle at the centre of the

plane of projection, equal to the angle made by these circles on the sphere.

For, since both these circles are perpendicular to the plane of projection, the angle made by their intersections with this plane is the same as the angle made by these circles.

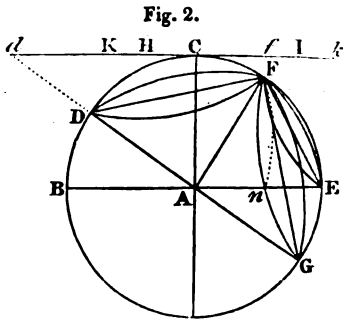
PROP. III. THEOR. III. Any less circle parallel to the plane of projection is projected into a circle whose centre is the pole of projection, and its radius is equal to the tangent of the distance of the circle from the pole of projection.

Let the circle PI (fig. 1) be parallel to the plane GF, then the equal arches PC, CI, are projected into the equal tangents GC, CH; and therefore C, the point of contact and pole of the circle PI and of the projection, is the centre of the representation G, H.

COROL. If a circle be parallel to the plane of projection, and 45° from the pole, it is projected into a circle equal to a great circle of the sphere; and therefore may be considered as the primitive circle, and its radius the radius of projection.

PROP. IV. THEOR. IV. A less circle not parallel to the plane of projection is projected into a conic section, whose transverse axis is in the line of measures; and the distance of its nearest vertex from the centre of the plane of projection is equal to the tangent of its nearest distance from the pole of projection; and the distance of the other vertex is equal to the tangent of the great distance.

Any less circle is the base of a cone whose vertex is at A, fig. 2; and this cone being pro-



duced, its intersection with the plane of projection will be a conic section. Thus the cone DAF, having the circle DF for its base, being produced, will be cut by the plane of projection in an ellipse whose transverse diameter is  $df$ ; and  $Cd$  is the tangent of the angle  $CAD$ , and  $Cf$  the tangent of  $CAF$ . In like manner, the cone AFE, having the side AE parallel to the line of measures  $df$ , being cut by the plane of projection, the section will be a parabola, of which  $f$  is the nearest vertex, and the point into which E is projected is at an infinite distance. Also the cone AFG, whose base is the circle FG, being cut by the plane of projection, the section will be a hyperbola; of which  $f$  is the nearest vertex; and GA being produced gives  $d$  the other vertex.

COROL. 1. A less circle will be projected into an ellipse, a parabola, or hyperbola, accord-

ing as the distance of its most remote point is less, equal to, or greater than, 90°.

2. If H be the centre, and K,  $k$ ,  $h$ , the focus of the ellipse, hyperbola, or parabola; then  $HK = \frac{Ad - Af}{2}$  for the ellipse;  $Hh = \frac{Ad + Af}{2}$  for the hyperbola; and  $fn$  being drawn perpendicular to AE  $fl = \frac{nE + Ff}{2}$  for the parabola.

PROP. V. THEOR. V. Let the plane TW, fig. 1, Plate PROJECTION OF THE SPHERE, be perpendicular to the plane of projection TV, and BCD a great circle of the sphere in the plane TW. Let the great circle BED be projected into the straight line  $bek$ . CQS perpendicular to  $bk$ , and  $Cm$  parallel to it and equal to CA, and make QS equal to Qm; then any angle QSt is the measure of the arch Qt of the projected circle.

Join AQ: then, because Cm is equal to CA, the angle Qcm equal to QCA, each being a right angle, and the side QC common to both triangles; therefore Qm, or its equal QS, is equal QA. Again, since the plane ACQ is perpendicular to the plane TV, and bQ to the intersection CQ; therefore bQ is perpendicular both to AQ and QS: hence, since AQ and QS are equal, all the angles at S cut the line bQ in the same points as the equal angles at A. But by the angles at A the circle BED is projected into the line bQ. Therefore the angles at S are the measures of the parts of the projected circle bQ; and S is the dividing centre thereof.

COROL. 1. Any great circle bQt is projected into a line of tangents to the radius SQ.

2. If the circle bC pass through the centre of projection, then the projecting point A is the dividing centre thereof, and Cb is the tangent of its correspondent arch CB to CA, the radius of projection.

PROP. VI. THEOR. VI. Let the parallel circle GLH, fig. 1, be as far from the pole of projection C as the circle FNI is from its pole; and let the distance of the poles CP be bisected by the radius AO; and draw bAD perpendicular to AO; then any straight line bQt drawn through b will cut off the arches  $h$ ,  $l$ ,  $F$ ,  $n$ , equal to each other in the representations of these equal circles in the plane of projection.

Let the projections of the less circles be described. Then, because BD is perpendicular to AO, the arches BO, DO, are equal; but, since the less circles are equally distant each from its respective pole, therefore the arches FO, OH, are equal; and hence the arch BF is equal to the arch DH. For the same reason the arches BN, DL, are equal; and the angle FBN is equal to the angle LDH; therefore, on the sphere, the arches FN, HL, are equal. And since the great circle BNLD is projected into the straight line bQnl, &c., therefore  $n$  is the projection of N, and  $l$  that of L: hence  $fn$ ,  $hl$ , the projections of FN, HL, respectively, are equal.

PROP. VII. THEOR. VII. If Fnk, hlg, fig. 2, be the projections of two equal circles, whereof one is as far from its pole P as the other from its pole C, which is the centre of projection; and if the distance of the projected poles C, p, be di-

vided in  $o$ , so that the degrees in  $C o, op$ , be equal, and the perpendicular  $oS$  be erected to the line of measures  $gh$ . Then the line  $pn, Cl$ , drawn from the poles  $C, p$ , through any point  $Q$  in the line  $oS$ , will cut off the arches  $F n, hl$ , equal to each other, and to the angle  $QCp$ .

The great circle  $AO$  perpendicular to the plane of the primitive is projected into the straight line  $oS$  perpendicular to  $gh$ , by Prop. i. Cor. 3. Let  $Q$  be the projection of  $q$ ; and since  $pQ, CQ$ , are straight lines, they are therefore the representations of the arches  $Pq, Cq$ , of great circles. Now, since  $PqC$  is an isosceles spherical triangle, the angles  $PCQ, CPQ$ , are therefore equal; and hence the arches  $Pq, Cq$ , produced will cut off equal arches from the given circles  $FI, GH$ , whose representations  $F n, hl$ , are therefore equal: and, since the angle  $QCp$  is the measure of the arch  $hl$ , it is also the measure of its equal  $F n$ .

COROL. Hence, if from the projected pole of any circle a perpendicular be erected to the line of measures, it will cut off a quadrant from the representation of that circle.

PROP. VIII. THEOR. VIII. Let  $Fnk$ , fig. 2, be the projection of any circle  $FI$ , and  $p$  the projection of its pole  $P$ . If  $Cg$  be the cotangent of  $CA, P$ , and  $gB$  perpendicular to the line of measures  $gC$ , let  $CAP$  be bisected by  $AO$ , and the line  $oB$  drawn to any point  $B$ , and also  $pB$ , cutting  $Fnk$  in  $d$ ; then the angle  $goB$  is the measure of the arch  $Fd$ .

The arch  $PG$  is a quadrant, and the angle  $goA = gPA + oAP = gAC + oAP = gAC + CAo = gAo$ ; therefore  $gA = go$ ; consequently  $o$  is the dividing centre of  $gB$ , the representation of  $GA$ ; and hence by Prop. V. the angle  $goB$  is the measure of  $gB$ . But, since  $pg$  represents a quadrant, therefore  $p$  is the pole of  $gB$ ; and hence the great circle  $p dB$ , passing through the pole of the circles  $gB$  and  $F n$ , will cut off equal arches in both, that is,  $F d = gB = \text{angle } goB$ .

COROL. The angle  $goB$  is the measure of the angle  $gpB$ . For the triangle  $gpB$  represents a triangle on the sphere, wherein the arch which  $gB$  represents is equal to the angle which the angle  $p$  represents; because  $gp$  is a quadrant; therefore  $goB$  is the measure of both.

PROP. IX. PROB. I. To draw a great circle through a given point, and whose distance from the pole of projection is equal to a given quantity.

Let  $ADB$ , fig. 3, be the projection,  $C$  its pole or centre, and  $P$  the point through which a great circle is to be drawn: through the points  $P, C$ , draw the straight line  $PCA$ , and draw  $CE$  perpendicular to it: make the angle  $CAE$  equal to the given distance of the circle from the pole of projection  $C$ ; and from the centre  $C$ , with the radius  $CE$ , describe the circle  $EFG$ : through  $P$  draw the straight line  $PIK$ , touching the circle  $EFG$  in  $I$ , and it will be the projection of the great circle required.

PROP. X. PROB. II. To draw a great circle perpendicular to a great circle which passes through the pole of projection, and at a given distance from that pole.

Let  $ADB$ , fig. 3, be the primitive, and  $CI$  the given circle: draw  $CL$  perpendicular to  $CI$ ,

and make the angle  $CLI$  equal to the given distance: then the straight line  $CP$ , drawn through  $I$  parallel to  $CL$ , will be the required projection.

PROP. XI. PROB. III. At a given point in a projected great circle, to draw another great circle to make a given angle with the former; and, conversely, to measure the angle contained between two great circles.

Let  $P$ , fig. 4, be the given point in the given great circle  $PB$ , and  $C$  the centre of the primitive: through the points  $P, C$ , draw the straight line  $POG$ , and draw the radius of the primitive  $CA$  perpendicular thereto; join  $PA$ ; to which draw  $AG$  perpendicular: through  $G$  draw  $BGD$  at right angles to  $GP$ , meeting  $PB$  in  $B$ ; bisect the angle  $CAP$  by the straight line  $AO$ ; join  $BO$ , and make the angle  $BOD$  equal to that given; then,  $DP$  being joined, the angle  $BPD$  will be that required.

If the measure of the angle  $BPD$  be required, from the points  $B, D$ , draw the lines  $BO, DO$ , and the angle  $BOD$  is the measure of  $BPD$ .

PROP. XII. PROB. IV. To describe the projection of a less circle parallel to the plane of projection, and at a given distance from its pole.

Let  $ADB$ , fig. 3, be the primitive, and  $C$  its centre: set the distance of the circle from its pole, from  $B$  to  $H$ , and from  $H$  to  $D$ ; and draw the straight line  $AED$ , intersecting  $CE$  perpendicular to  $BC$ , in the point  $E$ : with the radius  $CE$  describe the circle  $EFG$ , and it is the projection required.

PROP. XIII. PROB. V. To draw a less circle perpendicular to the plane of projection.

Let  $C$ , fig. 5, be the centre of projection, and  $TI$  a great circle parallel to the proposed less circle: at  $C$  make the angles  $ICN, TCO$ , each equal to the distance of the less circle from its parallel great circle  $TI$ ; let  $CL$  be the radius of projection, and from the extremity  $L$  draw  $LM$  perpendicular thereto; make  $CV$  equal to  $LM$ , or  $CF$  equal to  $CM$ ; then, with the vertex  $V$  and asymptotes  $CN, CO$ , describe the hyperbola  $WVK$ ; or, with the focus  $F$  and  $CV$ , describe the hyperbola, and it will be the perpendicular circle described.

PROP. XIV. PROB. VI. To describe the projection of a less circle inclined to the plane of projection.

Draw the line of measures  $dp$ , fig. 6, and at  $C$ , the centre of projection, draw  $CA$  perpendicular to  $dp$ , and equal to the radius of projection: with the centre  $A$ , and the radius  $AC$ , describe the circle  $DCFG$ ; and draw  $RAE$  parallel to  $dp$ : then take the greatest and least distances of the circle from the pole of projection, and set them from  $C$  to  $D$  and  $F$  respectively; for the circle  $DF$ ; and from  $A$ , the projecting point, draw the straight lines  $Aff$ , and  $ADd$ ; then  $df$  will be the transverse axis of the ellipse: but if  $D$  fall beyond the line  $RE$ , as at  $G$ , then from  $G$  draw the line  $GAd$ , and  $df$  is the transverse axis of an hyperbola: and if the point  $D$  fall in the line  $RE$ , as at  $E$ , then the line  $A E$  will not meet the line of measures and the circle will be projected into a parabola whose vertex is  $f$ : bisect  $df$  in  $H$ , the centre, and for the ellipse take half the difference of the lines  $A d, A f$ , which laid from  $H$  will give



**K** the focus; for the hyperbola, half the sum of  $A d$ ,  $A f$  being laid from  $H$ , will give  $k$  its focus: then with the transverse axis  $d f$ , and focus  $K$ , or  $k$ , describe the ellipse  $d M f$ , or hyperbola  $f m$ , which will be the projection of the inclined circle: for the parabola, make  $E Q$  equal to  $F f$ , and draw  $f n$  perpendicular to  $A Q$ , and make  $f k$  equal to one half of  $n Q$ : then with the vertex  $f$ , and focus  $k$ , describe the parabola  $f m$ , for the projection of the given circle  $F E$ .

**PROP. XV. PROB. VII.** To find the pole of a given projected circle.

Let  $D M F$ , fig. 7, be the given projected circle, whose line of measures is  $D F$ , and  $C$  the centre of projection; from  $C$  draw the radius of projection  $C A$ , perpendicular to the line of measures, and  $A$  will be the projecting point: join  $A D$ ,  $A F$ , and bisect the angle  $D A F$  by the straight line  $A P$ ; hence  $P$  is the pole. If the given projection be an hyperbola, the angle  $f A G$ , fig. 6, bisected, will give its pole in the line of measures; and, in a parabola, the angle  $f A E$  bisected will give its pole.

**PROP. XVI. PROB. VIII.** To measure any portion of a projected great circle, or to lay off any number of degrees thereon.

Let  $E P$ , fig. 8, be the great circle, and  $I P$  a portion thereof to be measured: draw  $I C D$  perpendicular to  $I P$ ; let  $C$  be the centre, and  $C B$  the radius of projection, with which describe the circle  $E B D$ ; make  $I A$  equal to  $I B$ ; then  $A$  is the dividing centre of  $E P$ ; hence,  $A P$  being joined, the angle  $I A P$  is the measure of the arch  $I P$ . Or, if  $I A P$  be made equal to any given angle, then  $I P$  is the correspondent arch of the projection.

**PROP. XVII. PROB. IX.** To measure any arch of a projected less circle, or to lay off any number of degrees on a given projected less circle.

Let  $F n$ , fig. 9, be the given less circle, and  $P$  its pole: from the centre of projection  $C$  draw  $C A$  perpendicular to the line of measures  $G H$ , and equal to the radius of projection; join  $A P$ , and bisect the angle  $C A P$  by the straight line  $A O$ , to which draw  $A D$  perpendicular: describe the circle  $G H$ , as far distant from the pole of projection  $C$  as the given circle is from its pole  $P$ ; and through any given point  $n$ , in the projected circle  $F n$ , draw  $D n l$ , then  $H l$  is the measure of the arch  $F n$ . Or let the measure be laid from  $H$  to  $l$ , and the line  $D l$  joined will cut off  $F n$  equal thereto.

**PROP. XVIII. PROB. X.** To describe the gnomonic projection of a spherical triangle, when three sides are given; and to find the measures of either of its angles.

Let  $A B C$ , fig. 10, be a spherical triangle whose three sides are given: draw the radius  $C D$ , fig. 11, perpendicular to the diameter of the primitive  $E F$ ; and at the point  $D$  make the angles  $C D A$ ,  $C D G$ ,  $A D I$ , equal respectively to the sides  $A C$ ,  $B C$ ,  $A B$ , of the spherical triangle  $A B C$ , fig. 10, the lines  $D A$ ,  $D G$ , intersecting the diameter  $E F$ , produced if necessary in the points  $A$  and  $G$ ; make  $D I$  equal to  $D G$ ; then from the centre  $C$ , with the radius  $C G$ , describe an arch; and from  $A$ , with the distance  $A I$ , describe another arch, intersecting the for-

mer in  $B$ ; join  $A B$ ,  $C B$ , and  $A C B$  will be the projection of the spherical triangle, and the rectilineal angle  $A C B$  is the measure of the spherical angle  $A C B$ , fig. 10.

**PROP. XIX. PROB. XI.** The three angles of a spherical triangle being given, to project it, and to find the measures of the sides.

Let  $A B C$ , fig. 12, be the spherical triangle of which the angles are given: construct another spherical triangle  $E F G$ , whose sides are the supplements of the given angles of the triangle  $A B C$ ; and with the sides of this supplemental triangle describe the gnomonic projection, &c., as before. The supplemental triangle  $E F G$  has also a supplemental part  $E F g$ ; and when the sides  $G E$ ,  $G F$ , which are substituted in place of the angles  $A$ ,  $B$ , are obtuse, their supplements  $g E$ ,  $g F$ , are to be used in the gnomonic projection of the triangle.

**PROP. XX. PROB. XII.** Given two sides, and the included angle of a spherical triangle, to describe the gnomonic projection of that triangle, and to find the measures of the other parts.

Let the sides  $A C$ ,  $C B$ , and the angle  $A C B$ , fig. 10, be given: make the angles  $C D A$ ,  $C D G$ , fig. 13, equal respectively to the sides  $A C$ ,  $C B$ , fig. 10; also make the angle  $A C B$ , fig. 13, equal to the spherical angle  $A C B$ , fig. 10, and  $C B$  equal to  $C G$ , and  $A B C$  will be the projection of the spherical triangle.

To find the measure of the side  $A B$ : from  $C$  draw  $C L$  perpendicular to  $A B$ , and  $C M$  parallel thereto, meeting the circumference of the primitive in  $M$ ; make  $L N$  equal to  $L M$ ; join  $A N$ ,  $B N$ , and the angle  $A B N$  will be the measure of the side  $A B$ . To find the measure of either of the spherical angles, as  $B A C$ : from  $D$  draw  $D K$  perpendicular to  $A D$ , and make  $K H$  equal to  $K D$ : from  $K$  draw  $K I$  perpendicular to  $C K$ , and let  $A B$  produced meet  $K I$  in  $I$ , and join  $H I$ : then the rectilineal angle  $K H I$  is the measure of the spherical angle  $B A C$ . By proceeding in a similar manner, the measure of the other angle will be found.

**PROP. XXI. PROB. XIII.** Two angles and the intermediate side given, to describe the gnomonic projection of the triangle; and to find the measures of the remaining parts.

Let the angles  $C A B$ ,  $A C B$ , and the side  $A C$  of the spherical triangle  $C D A$ , fig. 10, be given: make the angle  $C D A$ , fig. 13, equal to the measure of the given side  $A C$ , fig. 10; and the angle  $A C B$ , fig. 13, equal to the angle  $A C B$ , fig. 10, produce  $A C$  to  $H$ , draw  $D K$  perpendicular to  $C K$ , and make the angle  $K H I$  equal to the spherical angle  $C A B$ : from  $I$ , the intersection of  $K I$ ,  $H I$ , to  $A$  draw  $I A$ , and let it intersect  $C B$  in  $B$ , and  $A C B$ , fig. 10. The unknown parts of this triangle may be measured by last problem.

**PROP. XXII. PROB. XIV.** Two sides of a spherical triangle, and an angle opposite to one of them given, to describe the projection of the triangle; and to find the measure of the remaining parts.

Let the sides  $A C$ ,  $C B$ , and the angle  $B A C$  of the spherical triangle  $A B C$ , fig. 10, be given: make the angles  $C D A$ ,  $C D G$ , fig. 13, equal respectively to the measures of the given sides

AC, BC: draw DK perpendicular to AD, make KH equal to DK, and the angle KHI equal to the given spherical angle BAC: draw the perpendicular KI, meeting HI in I; join AI; and from the centre C, with the distance CG, describe the arch GB, meeting AI in B; join CB, and ABC will be the rectilinear projection of the spherical triangle ABC, fig. 10; and the measures of the unknown parts of the triangle may be found as before.

PROP. XXIII. PROB. XV. Given two angles and a side opposite to one of them, to describe the gnomonic projection of the triangle, and to find the measures of the other parts.

Let the angles A, B, and the side BC of the triangle ABC, fig. 12, be given: let the supplemental triangle EFE be formed, in which the angles E, F, G, are the supplements of the sides BC, CA, AB, respectively, and the sides EF, FG, GE, the supplements of the angles C, A, B. Now, at the centre C, fig. 13, make the angles CDA, CDK, equal to the measures of the sides GE, GF, respectively, being the supplements of the angles B and A; and let the lines DA, DK, intersect the diameter of the primitive EF, in the points A and K: draw DG perpendicular to AD, make GH equal to DG, and at the point H make the angle GHI equal to the angle E, or to its supplement; and let EI, perpendicular to CH, meet HI in I, and join AI: then from the centre C, with the distance CG, describe an arch intersecting AI in B; join CB, and ABC will be the gnomonic projection of the given triangle ABC, fig. 12: the supplement of the angle ACB, fig. 13, is the measure of the side AB, fig. 12; the measures of the other parts are found as before.

Although this method of projection has, for the most part, been applied to dialling only, yet, from the preceding propositions, it appears that all the common problems of the sphere may be more easily resolved by this than by the ordinary methods of projection.

PROLN, *v. a.* A corruption of prune. To lop; cut; trim.

I sit and *proln* my wings  
After flight, and put new strings  
To my shafts. *Ben Jonson.*

The country husbandman will not give the *proining* knife to a young plant. *Id.*

PROLAPSUS, in surgery, a term used to denote the falling of peculiar parts of the body out of their natural situation, more particularly applied to the uterus, vagina, and rectum. See *SECRETARY*.

PROLATE. Lat. *prolatum*. To pronounce; to utter.

The pressures of war have somewhat cowed their spirits, as may be gathered from the accent of their words, which they *prolate* in a whining querulous tone, as if still complaining and crest fallen.

*Howel.*

Parrots, having been used to be fed at the *prolation* of certain words, may afterwards pronounce the same. *Ray.*

As to the *prolate* spheroidal figure, though it be the necessary result of the earth's rotation about its own axis, yet it is also very convenient for us.

*Cheyne's Philosophical Principles.*

PROLATE, in geometry, is applied to a spheroid produced by the revolution of a semi-ellipsis about its larger diameter. See *SPHEROID*.

PROLEGOMENA, in philology, preparatory discourses fixed to a book, &c., containing something necessary to enable the reader the better to understand the book or science, &c.

PROLEPSIS, *n. s.* } Fr. *prolepse*; Gr. PROLEPTICAL. } *προληψις*. A figure of rhetoric, in which objections are anticipated: in the manner of a prolepsis.

This was contained in my *prolepsis* or prevention of his answer. *Bramhall against Hobbes.*

The *proleptical* notions of religion cannot be so well defended by the professed servants of the altar. *Glanville. Theobald.*

This is a *prolepsis* or anachronism.

PROLETA'RIAN, *adj.* Mean; wretched; vile; vulgar. A mean word whose etymology we do not find.

Like speculators should foresee,  
From pharos of authority,  
Portended mischiefs farther than  
Low *proletarian* tything-men. *Hudibras.*

PROLIF'IC, *adj.* } Fr. *prolifique*; Lat. PROLIF'ICAL. } *proles* and *facio*.  
Every dispute in religion grew *prolifical*, and in ventilating one question, many new ones were started. *Decay of Piety.*

Main ocean flowed; not idle, but with warm  
*Prolif*ic humour soft'ning all her globe,  
Fermented the great mother to conceive,  
Satiates with genial moisture.

*Milton's Paradise Lost.*

Their fruits, proceeding from simpler roots, are not so distinguishable as the offspring of sensible creatures, and *prolifications* descending from double origins. *Browne.*

His vital power air, earth, and seas supplies,  
And breeds what'er is bred beneath the skies;  
For every kind, by thy *prolif*ic might,  
Springs. *Dryden.*

All dogs are of one species, they mingling together in generation, and the breed of such mixtures being *prolif*ic. *Ray.*

From the middle of the world,  
The sun's *prolif*ic rays are hurled;  
'Tis from that seat he darts those beams,  
Which quicken earth with genial flames.

*Prior.*

PRO'LIX, *adj.* } Fr. *prolire*; Lat. *prolixus*. PROLIXIOUS, } Long; tedious; verbose: PROLIXITY, } *prolixious* is a synonyme PROLIX'LY, *adv.* } coined by Shakspeare: prolixity and prolixness, tediousness; tiresome dilation.

Lay by all nicety and *prolixious* blushes.

*Shakspeare.*

It is true, without any slips of *prolixity*, or crossing the plain highway of talk, that the good Anthonio hath lost a ship. *Id.*

According to the caution we have been so *prolix* in giving, if we aim at right understanding the true nature of it, we must examine what apprehension mankind make of it. *Digby.*

In some other passages I may have, to shun *prolixity*, unawares slipped into the contrary extreme. *Boyle.*

On these *prolixly* thankful she enlarged. *Druden.*  
If the appellant appoints a term too *prolix*, the judge may then assign a competent term. *Ayliffe.*

Should I at large repeat

The bead-roll of her vicious tricks,

My poem would be too *prolix*. *Prior*.

Elaborate and studied *prolixity* in proving such points as nobody calls in question. *Waterland*.

**PROLOCUTOR**, *n. s.* Lat. *prolocutor*. The foreman; the speaker of a convocation.

The convocation the queen prorogued, though at the expence of Dr. Atterbury's displeasure, who was designed their *prolocutor*. *Swift*.

**PROLOGUE**, *n. s. & v. a.* Fr. *prologue*; Gr. *πρόλογος*; Lat. *prologus*. Preface; introduction to a discourse or performance: to introduce with a preface.

Come, sit, and a song.

—Shall we clap into 't roundly, without hawking, or spitting, or saying we are hoarse, which are the only *prologues* to a bad voice? *Shakespeare*.

If my death might make this island happy,

And prove the period of their tyranny,

I would expend it with all willingness;

But mine is made the *prologue* to their play. *Id.*

He his special nothing ever *prologues*. *Id.*

In her face excuse

Came *prologue*, and apology too prompt. *Milton*.

From him who rears a poem lank and long,

To him who strains his all into a song;

Perhaps some bonny Caledonian air,

All birks and braes, though he was never there;

Or, having whelped a *prologue* with great pains,

Feels himself spent, and fumbles for his brains;

A *prologue* interdashed with many a stroke—

An art contrived to advertise a joke,

So that the jest is clearly to be seen,

Not in the words—but in the gap between:

Manner is all in all, whate'er is writ,

The substitute for genius, sense, and wit. *Couper*.

**PROLONG'**, *v. a.* } Fr. *prolonger*; Lat.

**PROLONGATION**, *n. s.* } *pro* and *longus*. To lengthen out; continue; draw out: hence, corruptly, to put off a long time: prolongation is the act of lengthening or delaying.

To-morrow in my judgment is too sudden;

For I myself am not so well provided,

As else I would be were the day prolonged.

*Shakespeare*.

Nourishment in living creatures is for the *prolongation* of life. *Bacon's Natural History*.

This ambassage concerned only the *prolongation* of days for payment of monies. *Id. Henry VII.*

Henceforth I fly not death, nor would prolong

Life much. *Milton*.

The unhappy queen with talk prolonged the night.

*Dryden*.

**PROLUSION**, *n. s.* Lat. *prolusio*. Entertainment; performance of diversion.

It is memorable, which Favianus Strada, in the first book of his academical *prolusions*, relates of Suarez. *Hakewill*.

**PROME**, or **PRONE**, a city of the Birnan empire, is situated on the eastern bank of the Irrawaddy, in a fine fertile plain, and was formerly surrounded by two walls, the exterior of timber, and the interior of brick. It is larger than Rangoon, and carries on a considerable trade in timber, grain, oil, wax, ivory, iron, lead, and flag-stones. It is said to have been once the capital of a dynasty. At present, with the adjoining territory, it forms the estate or appanage of one of the king's sons, called the prince of

Prome; and there is here a royal menagerie of elephants. The ruins of the ancient city extend beyond the modern town, and contain a number of temples dedicated to Boodh. Long. 95° E., lat. 18° 50' N.

**PROMETHEUS**, the son of Japetus, supposed to have been the first discoverer of the art of striking fire by flint and steel; which gave rise to the fable of his stealing fire from heaven. This fable is variously related by different authors. Prometheus, as most say, being a man of subtle and crafty genius, in order to find out whether Jupiter was really worthy to be reckoned a god, slew two oxen, and stuffed one of the skins with the flesh, and the other with the bones of the victims, the latter of which was chosen by Jupiter. The god, resolved to be revenged upon all mankind for this insult, deprived them of the use of fire; but Prometheus, with the assistance of Minerva, who had already aided him by her advice in forming the body of a man of tempered clay, contrived to ascend up to heaven, and, approaching the chariot of the sun, stole from thence the sacred fire, which he brought down to earth in a ferula. Jupiter, incensed at this strange and audacious enterprize, ordered Mercury to carry him to Mount Caucasus, and chain him to a rock, where an eagle was eternally to prey upon his liver. This part of the history of Prometheus and his subsequent deliverance either by Hercules or Jupiter himself, abounds with fictions, which are supposed to contain some ancient facts under this disguise. M. Bannier supposes that this is merely a continuation of the history of the Titans. Prometheus, as he conjectures, was not exempt from the persecutions which harassed the other Titans. As he returned into Scythia, which he durst not quit so long as Jupiter lived, that god is said to have bound him to Caucasus. This prince, addicted to astrology, frequently retired to Mount Caucasus, as to a kind of observatory, where he contemplated the stars, and was, as it were, preyed upon by continual pining, or rather by vexation, on account of the solitary and melancholy life which he led. This is supposed to have given rise to the fable of the eagle or vulture that incessantly preyed upon his liver. Herodotus, however, alleges, that Prometheus was put in prison for not being able to stop the overflowing of a river, which from its rapidity was called the eagle, or at least that he was obliged to fly with a part of his subjects to the mountains to escape the inundation, till a traveller, represented by Hercules, undertook to dam it up by a mount, and to kill the eagle, as it may be said, by making its course regular and uniform; thus Prometheus was delivered by this hero from his prison, or retreat.

Diodorus Siculus says that Prometheus first discovered combustible materials fit for kindling and maintaining fire. Bannier is of opinion, that the origin of this fiction was, that Jupiter, having ordered all the shops where iron was forged to be shut up, lest the Titans should make use of it against him, Prometheus, who had retired into Scythia, there established good forges; hence came the 'Calybes,' those excellent blacksmiths; and, perhaps Prometheus also, not thinking to find fire in that country, brought

some thither in the stalk of the ferula, in which it may be easily preserved for several days. As for the two oxen which Prometheus is said to have slain, that he might impose upon Jupiter, this part of the fable is said to be founded upon his having been the first who opened victims with a view of drawing omens from the inspection of their entrails. According to Le Clerc, Prometheus is the same with Magog, the former being the son of Japetus, and the latter the son of Japhet, and grandson of Noah. Both Prometheus and Magog settled in Scythia; the latter invented or improved the art of founding metals, and of forging iron, which the poets attributed to Prometheus; and Diodorus too says, that he invented several instruments for making fire. The appellation Magog signifies vexation, as Prometheus was gnawed by a vulture.

PROMETHEUS and DAMASICHTION, two sons of Colrus, king of Athens, who conducted colonies into Asia Minor.—Paus. i. c. 3.

PROMINENT, *adj.* } Lat. *prominens*.  
 PROM'INENCE, or } Standing out beyond  
 PROM'INENCY, *n. s.* } another part; protuberant: the noun substantives both corresponding.

Whales are described with two prominent spouts on their heads, whereas they have but one in the forehead, terminating over the windpipe.

*Brown's Vulgar Errors.*

She has her eyes so prominent, and placed so that she can see better behind her than before her.

*More.*

Two goodly bowls of massy silver,  
 With figures prominent and richly wrought.

*Dryden.*

Some have their eyes stand so prominent, as the hare, that they can see as well behind as before them.

*Ray.*

It shows the nose and eyebrows, with the prominences and fallings in of the features.

*Addison.*

His evidence, if he were called by law  
 To swear to some enormity he saw,

For want of prominence and just relief,  
 Would hang an honest man, and save a thief.

*Couper.*

PROMISCUOUS, *adj.* } Lat. *promiscuus*.  
 PROM'ISCUOUSLY, *adv.* } Mingled; confused;  
 undistinguished: the adverb corresponding.

We beheld where once stood Ilium, called Troy  
*promiscuously* of Tros.

*Sandys's Journey.*

No man, that considers the *promiscuous* dispensations of God's providence in this world, can think it unreasonable to conclude, that after this life good men shall be rewarded, and sinners punished.

*Tillotson.*

Glory he requires, and glory he receives,  
*Promiscuous* from all nations.

*Milton's Paradise Lost.*

*Promiscuous* love by marriage was restrained.

*Roscommon.*

In rushed at once a rude *promiscuous* crowd;

The guards, and then each other overbear,  
 And in a moment throng the theatre.

*Dryden.*

Here might you see

Barons and peasants on the embattled field,  
 In one huge heap *promiscuously* amast.

*Philips.*

The earth was formed out of that *promiscuous* mass  
 of sand, earth, shells, subsiding from the water.

*Woodward.*

That generation, as the sacred writer modestly expresses it, married and gave in marriage without distinction. Vol. XVIII.

cretion or decency, but *promiscuously*, and with no better a guide than the impulses of a brutal appetite.

*Id.*

Clubs, diamonds, hearts, in wild disorder seen,  
 With throngs *promiscuous* strow the level green.

*Pope.*

A wild, where weeds and flowers *promiscuous*  
 shoot.

*Id.*

Unawed by precepts human or divine,  
 Like birds and beasts *promiscuously* they join.

*Id.*

PROM'ISE, *n. s.*, *v. a.* & *v. n.* } Fr. *promesse*,  
 PROM'ISE-BREACH, } *promesse*; Lat.  
 PROM'ISE-BREAKER, } *promissum*. Engage-  
 PROM'ISER, } ment to  
 PROM'ISORY, *adj.* } benefit: decla-  
 PROM'ISORILY, *adv.* } ration of benefit

to be conferred; hence grant, or hope of something promised; to make such declaration or engagement; assure by promise: the two compounds are sufficiently plain: a promiser is he who makes the engagement to benefit: promissory, of the nature of a promise.

O Lord, let thy *promise* unto David be established.

*1 Chronicles.*

Now are they ready, looking for a *promise* from thee.

*Acts.*

While they *promise* them liberty, they themselves are the servants of corruption.

*2 Peter ii. 18.*

As he *promised* in the law, he will shortly have mercy, and gather us together.

*2 Mac. ii. 18.*

I eat the air, *promise* crammed; you cannot feed capons so.

*Shakespeare.*

His *promises* were, as he then was, mighty;  
 But his performance, as he now is, nothing.

*Id.*

Your young prince Mamillius is a gentleman of the greatest *promise*.

*Id. Winter's Tale.*

*Promising* is the very air o' the' time: it opens the eyes of expectation: performance is ever the duller for his act.

*Shakespeare.*

Will not the ladies be afraid of the lion?

—I fear it, I *promise* you.

*Id.*

Criminal in double violation

Of sacred chastity, and of *promisebreach*.

*Id.*

He's an hourly *promisebreaker*, the owner of no one good quality worthy your entertainment.

*Id.*

Who let this *promiser* in? did you, good Diligence?

Give him his bribe again.

*Ben Jonson.*

As the preceptive part enjoins the most exact virtue, so is it most advantageously enforced by the *promissory*, which is most exquisitely adapted to the same end.

*Decay of Piety.*

What God commands is good; what he *promises* is infallible.

*Bp. Hall.*

Whoever seeks the land of *promise*, shall find many lets.

*Id.*

He that brought us into this field, hath *promised* us victory.

*Id. Contemplations.*

If he receded from what he had *promised*, it would be such a disobligation to the prince that he would never forget it.

*Clarendon.*

Nor was he obliged by oath to a strict observation of that which *promissorily* was unlawful.

*Brown.*

Duty still preceded *promise*, and strict endeavour only founded comfort.

*Fell.*

I could not expect such an effect as I found, which seldom reaches to the degree that is *promised* by the prescribers of any remedies.

*Temple's Miscellanies.*

Behold, she said, performed in every part

My *promise* made; and Vulcan's laboured art.

*Dryden.*

I dare *promise* for this play, that in the roughness of the numbers, which was so designed, you will see

N

somewhat more masterly than any of my former tragedies. *Id.*

Fear's a large *promiser*; who subject live  
To that base passion, know not what they give. *Id.*

More than wise men, when the war began, could  
*promise* to themselves in their most sanguine hopes. *Davenant.*

The *promissory* lyes of great men are known by  
shoudering, hugging, squeezing, smiling, and bow-  
ing. *Arbutnot.*

Let any man consider how many sorrows he would  
have escaped had God called him to his rest, and  
then say whether the *promise* to deliver the just from  
the evils to come, ought not to be made our daily  
prayer. *Wake.*

All the pleasure we can take, when we met these  
*promising* sparks, is in the disappointment. *Felton.*  
She bribed my stay, with more than human charms;  
Nay *promised*, vainly *promised*, to bestow  
Immortal life. *Pope's Odyssey.*

Thy maidens, grieved themselves at my concern,  
Oft gave me *promise* of a quick return;  
What ardently I wished, I long believed,  
And, disappointed still, was still deceived. *Cowper.*

And round the new discoverer quick they flocked  
In multitudes, and plucked, and with great haste  
Devoured; and sometimes in the lips 'twas sweet,  
And *promised* well; but, in the belly, gall. *Pollok.*

PROMISSORY NOTES are entirely on a par with  
bills, equally negotiable, and subject to the same  
duties.

PRO'MONT, *n. s.* } Fr. *promontoire*; Lat.  
PROMONTORY. } *promontorium*. 'Promont,  
I have observed,' says Johnson, 'only in Suck-  
ling.' A headland; cape; high peninsula; or  
part of a peninsula.

Like one that stands upon a *promontory*,  
And spies a far off shore where he would tread.  
*Shakspeare.*

The land did shoot out with a great *promontory*.  
*Abbot.*

The waving sea can with each flood  
Bathe some high *promont*. *Suckling.*

They, on their heads,  
Main *promontories* flung, which in the air  
Came shadowing, and opprest whole legions armed.  
*Milton.*

Every gust of rugged winds,  
That blows from off each beaked *promontory*. *Id.*  
If you drink tea upon a *promontory* that overhangs  
the sea, it is preferable to an assembly. *Pope.*

PROMOTE', *v. a.* } Fr. *promouvoir*; Lat.  
PROMO'TER, *n. s.* } *promoveo, promotus*. To  
PROMO'TION, } forward; to advance;  
PROMOVE', *v. a.* } elevate; prefer: pro-  
moter is used in an obsolete sense for informer;  
approver: promotion is advancement; prefer-  
ment: promote, an obsolete synonyme of pro-  
mote.

I will *promote* thee unto very great honour.  
*Numbers.*  
Shall I leave my fatness wherewith they honour  
God and man, and go to be *promoted* over the trees?  
*Judges ix. 9.*

Many fair *promotions*  
Are daily given to ennoble those,  
That scarce, some two days since, were worth a noble.  
*Shakspeare.*

The high *promotion* of his grace of Canterbury  
Who holds his state at door 'mongst pursuivants. *Id.*  
His eyes be *promoters*, some trespass to spie.  
*Tusser.*

Next to religion, let your care be to *promote* jus-  
tice. *Bacon*

Informers and *promoters* oppress and ruin the es-  
tates of many of his best subjects. *Drummond.*

Never yet was honest man,  
That ever drove the tale of love;  
It is impossible, nor can  
Integrity our ends *promove*. *Suckling.*

Nothing lovelier can be found,  
Than good works in her husband to *promote*.  
*Milton.*

Did I solicit thee  
From darkness to *promote* me? *Id.*

My rising is thy fall,  
And my *promotion* will be thy destruction. *Id.*  
Knowledge hath received little improvement from  
the endeavours of many pretended *promoters*.  
*Glanville.*

Making useless offers, but *promoving* nothing.  
*Fell.*

Thou youngest virgin-daughter of the skies,  
Made in the last *promotion* of the blest;  
Whose palms, new plucked from paradise,  
In spreading branches more sublimely rise.  
*Dryden.*

He that talks deceitfully for truth, must hurt it  
more by his example than he *promotes* it by his argu-  
ments. *Atterbury.*

Our Saviour makes this return, fit to be engraven  
in the hearts of all *promoters* of charity: Verily, I  
say unto you, inasmuch as you have done it unto one  
of the least of these my brethren, ye have done it  
unto me. *Id.*

Frictions of the extreme parts *promote* the flux of  
the juices in the joints. *Arbutnot.*

PROMPT, *adj. & v. a.* } Fr. *prompt*; Ital.  
PROMP'TER, *n. s.* } *pronto*; Latin,  
PROMP'TITUDE, } *promptus*. Quick;  
PROMP'TLY, *adv.* } ready; acute; easy;  
PROMP'TNESS, *n. s.* } unobstructed; pert  
PROMP'TURE. } to assist; make  
ready or perfect; instigate; incite: a *prompter*  
is a suggester; admonisher; reminder: *promp-*  
*titude* and *prompter*, readiness; quickness; ap-  
*titude*; *prompture*, suggestion; obsolete.

Sitting in some place, where no man shall *prompt*  
him, let the child translate his lesson. *Ascham.*

Tell him, I'm *prompt*  
To lay my crown at's feet, and there to kneel.  
*Shakspeare.*

My voice shall sound as you do *prompt* mine ear,  
And I will stoop and humble my intents  
To your well practised wise directions. *Id.*

Were it my cue to fight, I should have known it  
Without a *prompter*. *Id. Othello.*

Though he hath fallen by *prompture* of the blood;  
Yet hath he in him such a mind of honour,  
That had he twenty heads to tender down  
On twenty bloody blocks he'd yield them up.  
*Shakspeare.*

None could hold the book so well to *prompt* and  
instruct this stage play, as she could. *Bacon.*

The reception of light into the body of the building  
was very *prompt*, both from without and from within.  
*Wotton.*

If they *prompt* us to anger, their design makes use  
of it to a further end, that the mind, being thus dis-  
quieted, may not be easily composed to prayer.

He that does his merchandise chearfully, *prompt-*  
*ly*, and readily, and the works of religion slowly, it  
is a sign that his heart is not right with God.  
*Taylor.*

Very discerning and *prompt* in giving orders, as  
occasions required. *Clarendon.*

*Prompt* eloquence

Flowed from their lips in prose or numerous verse.  
*Milton.*  
 Rage prompted them at length and found them arms.  
*Id.*  
 The inconceivable imperfections of ourselves will hourly prompt us of our corruption, and loudly tell us we are sons of earth.  
*Brown.*  
 He needed not one to prompt him, because he could say the prayers by heart.  
*Stillingfleet.*  
 I was too hasty to condemn unheard;  
 And you, perhaps, too prompt in your replies.  
*Druden.*

We understand our duty without a teacher, and acquit ourselves as we ought to do without a prompter.  
*L'Estrange.*  
 Had not this stop been given him by that accidental sickness, his great courage and promptness of mind would have carried him directly forward to the enemy, till he had met him in the open plains of Persia.  
*South.*  
 Every one some time or other dreams he is reading books, in which case the invention prompts so readily that the mind is imposed on.  
*Addison.*

Still arose some rebel slave,  
 Prompter to sink the state than he to save.  
*Prior.*  
 Firm and rigid muscles, strong pulse, activity, and promptness in animal actions, are signs of strong fibres.  
*Arbutnot.*  
 To the stern sanction of the offended sky,  
 My prompt obedience bows.  
*Pope.*  
 Kind occasion prompts their warm desires.  
*Id.*  
 The priestly brotherhood, devout, sincere,  
 From mean self-interest, and ambition clear,  
 Their hope in heaven, servility their scorn,  
 Prompt to persuade, expostulate, and warn.  
*Courper.*

**PROMPTUARY**, *n. s.* Fr. *promptuaire*; Lat. *promptuarium*. A storehouse; repository; magazine.

This stratum is still expanded at top, serving as the seminary or *promptuary*, that furnisheth forth matter for the formation of animal and vegetable bodies.  
*Woodward.*

**PROMULGATE**, or **PROMULGE**, *v. a.* Lat. *promulgo*. To publish; make known  
**PROMULGATION**, *n. s.* } by open declaration:  
**PROMULGATOR**, } promulgation, the de-  
**PROMULGER**, } clarator made; promul-  
 gator and promulger, he who makes it.

Those albeit I know he nothing so much hateful as to promulgate, yet I hope that this will occasion him to put forth divers other goodly works.  
*Spenser.*  
 The stream and current of this rule hath gone as far, it hath continued as long as the very promulgation of the gospel.  
*Hooker.*  
 Those to whom he entrusted the promulgating of the gospel, had far different instructions.  
*Decay of Piety.*

Eternal promulgation, or speaking thereof, did not alter the same, in respect of the inward form or quality.  
*White.*  
 It is certain laws, by virtue of any sanction they receive from the promulgated will of the legislature, reach not a stranger, if by the law of nature every man hath not a power to punish offences against it.  
*Lacke.*

The very promulgation of the punishment will be part of the punishment, and anticipate the execution.  
*South.*  
 The chief design of them is, to establish the truth of a new revelation in those countries, where it is first promulged and propagated.  
*Atterbury.*

The promulgators of our religion, Jesus Christ and his apostles, raised men and women from the dead, not once only, but often.  
*Id.*

**PRONAOS**, in the ancient architecture, a porch to a church, a palace, or other spacious building. See **PORCH**.

**PRONAPIDES**, an ancient Greek poet of Athens, who was preceptor to Homer. He also, it is said, first taught the Greeks to write from the left to the right; as they formerly wrote in the Oriental manner from right to left.

**PRONATION**, among anatomists. The radius of the arm has two kinds of motion, the one called pronation, the other supination. Pronation is that whereby the palm of the hand is turned downwards; and supination, the opposite motion thereto, is that whereby the back of the hand is turned downwards.

**PRONE**, *adj.* Lat. *pronus*. Bending downwards; not erect;  
**PRONENESS**, *n. s.* } precipitous; headlong;  
**PRONITY**. } propense; inclined: proneness and pronity, state of being prone.

The Holy Spirit saw that mankind is unto virtue hardly drawn, and that righteousness is the less accounted of by reason of the *proneness* of our affections to that which delighteth.  
*Hooker.*

The soul being first from nothing brought, When God's grace fails her, doth to nothing fall;  
 And this declining *proneness* unto nothing, Is e'en that sin that we are born withal.  
*Davies.*

Of this mechanic *pronity*, I do not see any good tendency.  
*More's Divine Dialogues.*

There wanted yet a creature not prone, And brute as other creatures, but endued With sanctity of reason, might erect His stature, and upright, with front serene Govern the rest.  
*Milton's Paradise Lost.*

Down thither prone in flight He speeds.  
*Id.*

Upon these three positions in man, wherein the spine can only be at right lines with the thigh, arise those postures, *prone*, *supine*, and *erect*.

He instituted this worship, because of the carnality of their hearts, and the *proneness* of the people to idolatry.  
*Tillotson.*

Those who are ready to confess him in judgment and profession, are very *prone* to deny him in their doings.  
*South.*

If we are *prone* to sedition, and delight in change, there is no cure more proper than trade, which supplies business to the active, and wealth to the indigent.  
*Addison.*

How great is the *proneness* of our nature to comply with this temptation!  
*Rogers.*

Since the floods demand, For their descent a *prone* and sinking land:  
 Does not this due declivity declare,  
 A wise director's providential care?  
*Blackmore.*

The *proneness* of good men to commiserate want in whatsoever shape it appears.  
*Atterbury.*  
 Still *prone* to change, though still the slaves of state.  
*Pope.*

While storms remote but murmur on thy ear,  
 Nor waves in ruinous uproar round thee roll,  
 Yet, yet a moment check thy *prone* career,  
 And curb the keen resolve that prompts thy soul.  
*Beattie.*

All else was *prone*, irrational, and mute,  
 And unaccountable, by instinct led.  
*Pollak.*

**PRONG**, *n. s.* Belg. *pronghen*, to squeeze. Minsheu.—Goth. *prionn*. A fork.

The cooks make no more ado, but, slicing it into little goblets, prick it on a *prong* of iron, and hang it in a furnace. *Sandys*.

Whacum his sea-coal *prong* threw by,  
And basely turned his back to fly. *Hudibras*.  
Be mindful,

With iron teeth of rakes and *prongs* to move  
The crusted earth. *Dryden's Virgil's Georgicks*.

**PRONOUN**, *n. s.* Fr. *pronom*; Lat. *pronomēn*. A part of speech; see the extract.

I, thou, he; we, ye, they, are names given to persons, and used instead of their proper names, from whence they had the name of *pronouns*, as though they were not nouns themselves, but used instead of nouns. *Clarke's Latin Grammar*.

**PRONOUNCE**, *v. a. & v. n.* } French *pron-*  
**PRONOUNCER**, *n. s.* } *noncer*; Latin  
**PRONUNCIATION**. } *pronuncio*. To  
speak; utter; utter solemnly or confidently;  
speak with confidence or authority: pronunciation  
is the act, art, or mode of utterance.

He *pronounced* all these words unto me with his  
mouth. *Jer. xxxvi. 18.*

I have *pronounced* the word, saith the Lord.  
*Jeremiah*.

She  
So good a lady, that no tongue could ever  
*Pronounce* dishonour of her.

*Shakspeare. Henry VIII.*

How confidently soever men *pronounce* of themselves, and believe that they are then most pious, when they are most eager and unquiet; yet 'tis sure this is far removed from the true genius of religion.

*Decay of Piety.*

Language of man *pronounced*  
By tongue of brute, and human sense expressed.

*Milton.*

Sternly he *pronounced* the rigid interdiction. *Id.*  
The design of speaking being to communicate our thoughts by ready, easy, and graceful *pronunciation*, all kind of letters have been searched out, that were serviceable for the purpose. *Holder.*

Though diversity of tongues continue, this would render the *pronouncing* them easier. *Id.*

It were easy to produce thousands of his verses, which are lame for want of half a foot, sometimes a whole one, and which no *pronunciation* can make otherwise. *Dryden.*

Absalom *pronounced* a sentence of death against his brother. *Locke.*

Every fool may believe and *pronounce* confidently: but wise men will, in matters of discourse, conclude firmly, and in matters of fact, act surely.

*South's Sermons.*

The *pronouncer* thereof shall be condemned in expenses. *Ayliffe.*

We do not believe the character which a man gives us of another, unless we have a good opinion of his own: so neither should we believe the verdict which the mind *pronounces*, till we first examine whether it be impartial and unbiassed. *Mason.*

And God, beholding, saw  
The fair design, that from eternity  
His mind conceived, accomplished; and, well pleased,  
His six days finished work most good *pronounced*,  
And man declared the sovereign prince of all.

*Pollak.*

**PRONUNCIATION**. Interweaving an English Lexicon with the other portions of our alphabet, we may be expected to say something on this

important part of a living language. It is that part of it, however, we apprehend, upon which instruction is least communicable by books; and what constitutes elegant or even correct pronunciation is so much matter of fashion, and ever-changing modifications, that 'Pronouncing Dictionaries' have, we confess, long given place in our library to many less laborious performances. Dr. Watts is said to have proposed in badinage, as a rule of English spelling and pronunciation, that the one should be as unlike the other as possible.

Mr. Walker, however, is clearly entitled to praise for his researches into this subject: yet he confesses that he was afraid to attempt all that he considered necessary, and in general contented himself with ascertaining, and exhibiting, existing, and what has been called polite usage. Nothing more than this, perhaps, can ever be accomplished; and in this he was certainly successful; so that his Dictionary is regarded as the standard of English pronunciation. But he has evidently, after all, attempted too much. For it cannot surely be necessary to mark the sound of every word in the English language: it must be quite sufficient to mark those in which pronunciation is likely to err. Such words only should be marked by a different spelling, which deviate in any respect from the analogy of the language: the pronunciation of all the rest may be sufficiently indicated by the accent, with the assistance, occasionally, of the marks  $\bar{\quad}$  and  $\grave{\quad}$ , the first denoting that a vowel is long—the second, that it is short: as, contemplāte, ālb. The reader will find the following particulars respecting English pronunciation and its marks worth consideration.

1. The accent should be understood as falling on the letter immediately preceding the mark or sign: as, ac'cent, n. accent', v. a.; fa'vor, endeavor.

2. When the letter immediately preceding the accentual mark is a vowel, it is long; but, if a consonant immediately precede the mark, the preceding vowel is short: thus, fa'vor, fab'ric, which is equivalent to favor, fabric.

3. Final *e* renders the preceding vowel long, except when it is followed by a double consonant: as, mate, mete, mite, mote, mute, nature, rēmo'te, &c., pronounced as if marked, māte, mēte, mīte, mōte, mūte, nā'ture, rēmō'te. But, when two or more consonants come between the final *e* and the preceding vowel, it is short: as, battle, babble, badge, &c., pronounced as if marked bāt'tle, bāb'ble, bād'ge. In such words as intes'tine, fu'tile, &c., the vowel preceding the final *e* is made short by Mr. Walker; but in the opinion of the writer it is better to make all such instances conform to the rule; and the long vowel sound is an improvement in all such connexions to the English language; for it is, in general, both harsh to the ear and hard to the mouth, from having too few *open* and too many *shut* vowel sounds.

4. When the accent is not placed on a vowel, and when it is not followed by a final *e* in the same syllable, the vowel is to be always considered short: as, fatt'en, hab'it, &c., pronounced as if marked fāt'tēn, hāb'it.

5. In monosyllables terminating with *all*, *a* has the same sound as *aw* or *au*: as, *all*, *ball*, *call*, &c., pronounced *awl*, *bawl*, *caul*. In all cases, when the accent is placed before the *l*, *a* is to be pronounced *aw*; when the accent is put after *l*, *a* is to be pronounced short: as, *fa'lse*, *ma'lt*, *fa'ter*; *al'b*, *al'titude*, *cal'umny*, *cal'let*; pronounced as if marked—*fa'wls*, *ma'wit*, *fa'w'ler*; *ä'lb*, *ä'l'titude*, &c.

6. The following diphthongs have uniformly the long sound of *a* (except when one of the vowels is in the italic character), *ay*, *ai*, *ei*, *ey*: as, *Maid*, *pail*, *say*, *rein*, *they*, &c., pronounced like *made*, *pale*, &c. But, when one of the vowels is silent, the other vowel is short: as, *plaid*, *rail'ery*, *mountain*, &c., pronounced *plad'*, *ra'ler'y*, *mountin*.

7. *Au*, *aw*, are to be uniformly considered as sounding the same as in *caul*, *awl*, except when the pronunciation of the words containing them is particularly indicated. For *au* before *n* is pronounced like *a* in *far*, and in the colloquial, words *ca'n't* and *sha'n't*, except when a different sound is particularly indicated: thus, *aunt*, *askaunce*, *askaunt*, *haunt*, &c., are pronounced like *† ant*, *† cant*.

8. *Ea*, *ee*, are generally pronounced like *e* long: as, *anneal*, *peel*, *fear*, *feed*. The exceptions, however, are numerous, and are thus marked in some pronouncing dictionaries: *bread'*, *head'*, *earl*, pronounced *bred*, *hed*, *erl*.

9. *Eu*, *eu*, *ue*, are always pronounced like *u* long, except when a difference is particularly indicated: as, *few*, *feud*, *due*. But after *r*, *ue*, *eu*, are generally pronounced like *oo*: as, *true*, *new*, pronounced *troo*, *scroo*.

10. *Oa* and *oe* always sound like long *o*, except when a difference is particularly indicated in the dictionary; as, *moat*, *sloe*, pronounced *moat*, *slö*.

11. *Oy*, *oi*, have uniformly the compound sound of *o* and *i*, except where a departure from rule is indicated: thus, *joy*, *spoil*, &c.

12. *Oo* has generally the same sound as in *food*, *soon*, *fool*, &c.

13. Before *l*, *u* has uniformly the sound of *oo* shortened, except when a difference is particularly indicated: as, *bull*, *full*, *handful*; the sole difference between *full* and *fool* is, that the diphthong in the last is longer than in the first.

14. *Ou*, *ou*, uniformly sound as in *our*, *now*, except when *u* or *u* is marked as silent, in which case the pronunciation is the same as long *o*: thus, *flour*, *source*, *mould*, pronounced, *möld*, *so'urc*, *flö*. When *ou* terminates a word of more than one syllable, it is uniformly pronounced like long *o*: as in *hollow*, *sorrow*, &c., pronounced *low'low*, *sor'row*.

15. In monosyllables *y* and *ie* are always pronounced like long *i*; but in words of more than one syllable they are pronounced like short *e*: as, *try*, *tries*, pronounced *tri*, *tries*, &c.; *carry*, *carries*, pronounced *carry*, *carries*, &c.

16. Before *nd*, *i* has uniformly the long sound; as in *mand*, *kind*, &c.: but every other vowel before *nd* is uniformly short; as in *hand*, *end*, *kind*, *fund*.

17. Before *lk*, *a* sounds *aw*, and *l* is silent; as in *balk*, *talk*, pronounced *bawk*, *tawk*.

18. Before *lm*, *a* has the broad German sound, and *l* is silent; as in *calm*, *balm*, &c.

19. Before *ll* and *ld*, *o* is always long: as, *poll*, *old*, *fold*, *cold*, &c., pronounced *pole*, *öld*, *föld*, &c.

20. Before single *r*, *a* has uniformly what is termed the broad German sound, except in unaccented syllables, where it has the common short sound: as, *far*, *part*, *partial*; *ram'part*, &c.; and before double *r*, *a* has uniformly the short sound; as in *carry*, *tarry*, &c.

21. Before *a*, *o*, *u*, *C* is always pronounced like *K*; but before *e*, *i*, *y*, it is pronounced like *S*: as, *card*, *cord*, *curd*, pronounced *kard*, *kord*, *kurd*; *cement*, *city*, *cynic*, pronounced *sement*, *sitty*, *cinnic*. When *c* ends a word or syllable, it always sounds the same as *k*; as, *mu'sic*, *flaccid*, *siccit'y*, pronounced *mu'sik*, *flak'sed*, *sik'sity*: *k* after *c* is now very properly discarded, except in such words as *back*, *pack*: as, *music*, *physic*, &c., not *musick*, *physick*. It would be well to discontinue the *k* in every case, (i. e. in connexion with *c*), or to substitute it for *c*, which last letter is wholly superfluous in the English alphabet; and, if *k* and *s* were made to supersede this double-sounding character, much inconvenience would be obviated.

22. *Ch* has three sounds, viz. *tsh*, as in *chair*, *child*, *chin*, &c.; *sh*, as in *chaise*, *chagrin*, *machine*, &c.; *k*, as in *chaos*, *character*, *chorus*, *anchor*, *mechanic*, *epoch*, &c. When *ci*, *ti*, *si*, come before *a*, *e*, *o*, they are to be considered as sounding like *sh*, with some exceptions, as, *special*, *occasion*, *diction*, *petition*, *captious*, &c. pronounced *speshal*, *okazhun*, *petishun*, *capshus*: *tious*, *cious*, are always pronounced *shus*; *cion*, *sion*, *tion*—*shun*; but short, as if put *shn*.

23. *G*, like *C*, has two sounds; before *a*, *o*, *u*, *l*, *r*, or when terminating a syllable, it is hard; as in *game*, *go*, *gun*, *fig*, *fag*, &c.; before *e*, *i*, *y*, *G* is pronounced like *J*; as in *gem*, *genus*, *gim*, *gibe* or *gybe*, *gymnastic*, *age*, *eulogy*, &c.; exceptions, however, occur, such as *get*, *geld*, &c. Such words as the following are not exceptions, because the *g* is properly the last letter of a syllable, and therefore has the hard sound, viz. *shaggy*, *shagged*, *ragged*, *rugged*, *dagger*, *anger*, *finger*, &c. The intention in doubling the *g* in *shaggy*, *beggar*, &c., was to indicate the hard sound. When *gn* begins or terminates a word, *g* is silent; as *gnaw*, *gnat*, *condign*, *malign*, *feign*, *deign*, *sign*—pronounced *naw*, *nat*, *condine*, *maline*, *fain*, *dain*, *sine*. The vowel preceding the silent *g* or *gh* is uniformly long; as *impugn*, *right*, *blight*, &c.—pronounced *impune* *rite*, *blite*. Except in *ghost*, *ghast*, and their derivatives (pronounced *gost*, *gast*), *gh* is to be considered as uniformly silent: there are a few instances in which it is pronounced *f*, as in *cough*, &c.—and *k*, as in *lough*—and *g* hard, as in *burgh*.

24. When *kn* begins a word, *k* is silent; as, *knab*, *knack*, *knee*, *know*, &c.—pronounced *nab*, *nak*, *nee*, *no*.

25. *H* is always sounded at the beginning of words, except in *heir*, *heirss*, *honest*, *honesty*, *honor*, *honorable*, *hospital*, *hostler*, *hour*, *humble*, *humor*, *humorous*, *humorsome*. It is always silent after *r*; as in *rhetoric*, *rhubarb*.



nyrrh. When the final letter, and preceded by a vowel, it is always silent; as in ah! oh! sirrah! When *wh* begins words, it is pronounced hoo; as in whale, wheel—pronounced hooale, hooeel, in one syllable. In the Saxon vocabulary, such words are more properly spelled hu or hw.

26. The affix *or*, *our*, is uniformly pronounced *ur*; as in candor or candour, favor or favour—pronounced candur, favur. The shut or short vowel sounds in unaccented syllables cannot be distinguished as having any difference; and therefore it seems unnecessary to mark *er* as if it were pronounced *ur* in such words as lover, mother, father, &c.

27. The affix *some* is uniformly pronounced sum; as in handsome, delightful—pronounced han'sum, deli'ghtsum. This affix is spelled in Saxon, som, sam, sum: and it would be well to return to sum, or at least to discard the final *e*; for, as we have so frequently intimated, spelling and pronunciation should coincide.

28. The affix *ous* is uniformly pronounced *us*; as in covetous, righteous—pronounced cu'vetus, rightyus; *ous* (like *our* for *or*) is the French mode of expressing the Latin affix *os*.

29. When *w* begins the word, it has the sound of oo; as in ware, wet, wile, &c.—pronounced *ouare*, *ooet*, *ooile*, in one syllable: *u* before *e*, *i*, *o*, has generally the same sound; as, languish, banquet, languor, language; pronounced lan'gwish, or langooish, ban'kwet, langwur, langwage.

30. *S* has two sounds, the one sharp and hissing, as in *us*, *this*; the other precisely like *z*; as in *his*, *was*, *as*, &c. Double *s* has uniformly the sharp hissing sound.

31. *Th* has two sounds; the one as in *thin*, &c.; the other as in *thine*. When not particularly indicated, *th* is always to be considered as having the first sound; but, when followed by final *c* in the same syllable, *th* has uniformly the second sound; as in *breathe*, *writhe*, &c. When *th* is pronounced as *t*, the *h* is marked as silent; thus, *thyme*, *asthma*, pronounced *time*, *ast'ma*.

32. *F* and *ph* have the same sound; and *f* sometimes that of *v*; double *f* has uniformly the sound of *f*, or *ph*, as in *off*, *staff*, &c.

33. Before *on* and *ous*, *i* generally sounds like *y*, at the beginning of a word or syllable; as in *minion*, *million*, *tedious*, &c., pronounced *mi-nyun*, *milyun*, *tedeyus*.

34. When final *e* comes after *l* and *r*, it is to be pronounced as if put before them; as in *fickle*, *mingle*, *theatre*, *nitre*, pronounced *fikkel*, *mingul*, *theater*, *niter*. This pronunciation is quite familiar to the French (from whom the mode of spelling and pronouncing such words was adopted), and other foreigners must remember that final *e* is never pronounced as a distinct syllable in the English language.

35. *T* is always silent between *s* and *en* or *le*; as in *hasten*, *listen*, *castle*, &c., pronounced *hay-sen*, *lissen*, *kassel*.

36. *X* has two sounds, viz. *ks* and *gs*, except when particularly marked, it is to be understood as having the first sound.

37. *Qu* has always the sound of *koo*.

38. The verbal affix *ed*, is seldom pronounced as a distinct syllable except after *d*; as *feared*,

confessed, pronounced *feard*, *confessed*; but in such words as *branded*, *commanded*, &c., it is a distinct syllable.

The irregular character of English pronunciation has been (like that of English spelling), too often noticed, and is too manifest to require any comment: whether it be more or less anomalous than that of other languages is a question of no importance; but there is evidently much importance, i. e. utility, in rendering it as simple and regular as possible. Influential speakers (who have always least reason to dread petty criticism) should set the example of bringing English pronunciation to English spelling. The latter might be materially reformed (see our article GRAMMAR) without much trouble; and the great desideratum is coincidence between the one and the other. It is in general, however, safer to make the pronunciation conform to the spelling, than to make the spelling conform to the pronunciation; and to make the one correspond to the other ought evidently to be a rule with every sensible speaker and writer.

In all those words which are differently pronounced by respectable speakers, that mode is worthy of preference which is most agreeable to analogy and most conformable to orthography; as, *yea*, pronounced *ye* and *yay*; *wound*, pronounced like *found* and *wound*; *break*, pronounced *breek* and *brake*; *oblige*, pronounced *oblige* and *obleege*; *knowledge*, pronounced *nōledge* and *nōlledge*, &c., &c. The first of these modes of pronunciation is evidently that which should be universally adopted. Influential speakers should endeavour to bring the general practice to analogy in all cases. It is unworthy of persons who have any respect for utility, to follow the blind guidance of mere custom, or to comply with the anomalous caprices of fashion. The only chance for simplicity, uniformity, and immutable stability to a living language, is to follow the guidance of reason. When learned or foreign words are adopted, they should be made to conform to the English idiom or manner of spelling and pronouncing. This plain sensible rule is surely better than pedantry or affectation: and in this we might profit by the example of the French, in imitating whose language we have given such a motley character to our own.

PROOF, *n. s. & adj.* } From PROVE, which  
PROOF'LESS. } see. Experiment;  
evidence; testimony; hence firm temper; impenetrability; armour hardened in a high degree; the rough draught, or copy of a printed sheet: as an adjective, impenetrable; capable of firm resistance; taking *to* or *against* before the object: proofless is, not to be proved, or destitute of proof.

Though the manner of their trial should be altered, yet the *proof* of every thing must be by the testimony of such persons as the parties shall produce. *Spenser.*

This has neither evidence of truth, nor *proof* sufficient to give it warrant. *Hooker.*

That which I shall report will bear no credit, Were not the *proof* so high. *Shakspeare.*

He Bellona's bridegroom, I apt in *proof*, Confronted him. *Id. Mabeth.*

Nothing can be more irrational than for a man to

doubt of, or deny the truth of any thing, because it cannot be made out by such kind of *proofs* of which the nature of such a thing is not capable. They ought not to expect either sensible *proof*, or demonstration of such matters as are not capable of such *proofs*, supposing them to be true. *Wilkins.*

One soul in both, whereof good *proof*  
This day affords. *Milton.*

Opportunity I here have had  
To try thee, sift thee, and confess have found thee  
*Proof* against all temptation, as a rock  
Of adamant. *Id. Paradise Regained.*

Some were so manifestly weak and *proofless*, that he must be a very courteous adversary, that can grant them. *Boyle.*

Those intervening ideas, which serve to shew the agreement of any two others, are called *proofs*.  
*Dryden.*

To me the cries of fighting helds are charms,  
Keen be thy sabre, and of *proof* my arms;  
I ask no other blessing of my stars. *Id.*

He past expression loved,  
*Proof* to disdain, and not to be removed. *Id.*

Guiltless of hate, and *proof* against desire;  
That all things weighs, and nothing can admire.  
*Id.*

My paper gives a timorous writer an opportunity of putting his abilities to the *proof*. *Addison.*

Deep in the snowy alps, a lump of ice  
By frost was hardened to a mighty price;  
*Proof* to the sun it now securely lies,  
And the warm dog-star's hottest rage defies. *Id.*  
When the mind is thoroughly tinctured, the man will be *proof* against all opposition. *Collier.*

Here for ever must I stay,  
Sad *proof* how well a lover can obey. *Pope.*  
I've seen you weary winter-sun  
Twice forty times return;  
And every time has added *proofs*,  
That man was made to mourn. *Burns.*

**PROOF**, in law and logic, is that degree of evidence which carries conviction to the mind. It differs from demonstration, which is applicable only to those truths of which the contrary is inconceivable. It differs likewise from probability, which produces for the most part nothing more than opinion, while proof produces belief.

**PROOF**, in printing. See **PRINTING**.

**PROOF**, in spirituous liquors, is a little white lather which appears on the top of the liquor when poured into a glass. This lather, as it diminishes, forms itself into a circle called by the French the chaplet, and by the English the head or bubble.

**PROOF OF ARTILLERY AND SMALL ARMS**, is a trial whether they stand the quantity of powder allotted for that purpose. Government allows eleven bullets of lead in the pound for the proof of muskets, and twenty-nine in two pounds, for service; seventeen in the pound for the proof of carbines, and twenty for service; twenty-eight in the pound for the proof of pistols, and thirty-four for service. When guns of a new metal, or of lighter construction, are proved, besides the common proof, they are fired 200 or 300 times, as quick as they can be, loaded with the common charge given in actual service. Proof of cannon is made to ascertain their being well cast, their having no cavities in their metal, and, in a word, their being fit to resist the effort of their charge of powder. In making this proof, the piece is laid

upon the ground, supported only by a piece of wood in the middle, of about five or six inches thick, to raise the muzzle a little; and then the piece is fired against a solid butt of earth. The tools used in the proof of cannon are these:—The searcher, an iron socket with branches, from four to eight in number, bending outwards a little, with small points at their ends: to this socket is fixed a wooden handle, from eight to twelve feet long, and one inch and a half in diameter. This searcher is introduced into the gun after each firing, and turned gently round to discover the cavities within; if any are found they are marked on the outside with chalk; and then the searcher with one point is introduced: about which point a mixture of wax and tallow is put, to take the impression of the holes; and if they are found of one-fourth of an inch deep, or of any considerable length, the gun is rejected as unserviceable. The reliever is an iron ring fixed to a handle, by means of a socket, so as to be at right angles; it serves to disengage the first searcher, when any of its points are retained in a hole, and cannot otherwise be got out.

A curious instrument for finding the principal defects in pieces of artillery was invented by lieutenant-general Desaguliers. This instrument discovers more particularly the defect of the piece not being truly bored; which is a very important one; for, when a gun is not properly bored, the most expert artillerist will not be able to make a good shot.

Every species of ordnance undergoes different kinds of proof before it is received into his majesty's service. They are gauged as to their several dimensions, internal and external, as to the accuracy of the position of the bore, the chamber, the vent, the trunnions, &c. They are fired with a regular charge of powder and shot, and afterwards searched to discover irregularities or holes produced by the firing. By means of engines, an endeavour is made to force water through them. They are examined internally, by means of light reflected from a mirror.

**PROOF OF MORTARS AND HOWITZERS** is performed by placing them on the ground on wood or bullets, of an elevation of 70°. The mirror is the only instrument to discover their defects. To use it, the sun must shine; the breech must be placed towards the sun, and the glass over against the mouth of the piece; it illuminates the bore and chamber sufficiently to discover the flaws in it.

**PROOFS IN ENGRAVING**. Proofs of prints were formerly a few impressions taken off in different stages of the engraver's process, that he might ascertain how far his labors had been successful, and when they were complete. The excellence of such impressions, worked with care under the artist's eye, occasioning them to be sought after, and liberally paid for, it has been customary, among our modern print-sellers, to take off a number under this name, from every plate of considerable value. On retouching a plate, it has been also usual, among the same conscientious fraternity, to cover the inscription, which was immediately added after the first proofs were obtained, with slips of paper, that a number of secondary proofs might also be created.

PROP, *v. a. & n. s.* Belg. *proppe, proppen.*  
To sustain; support; uphold: a stay; support;  
pillar.

Again, if by the body's *prop* we stand,  
If on the body's life, her life depend,  
As Melcager's on the fatal brand,  
The body's good she only would intend.

*Davies.*

That he might on many *props* repose,  
He strengths his own, and who his part did take.

*Daniel.*

Like these, earth unsupported keeps its place,  
Though no fix bottom *props* the weighty mass.

*Creech.*

Fairest unsupported flower  
From her best *prop* so far.

*Milton.*

The current of his vic'tries found no stop,  
Till Cromwell came, his party's chiefest *prop.*

*Waller.*

The *props* return  
Into thy house, that bore the burdened vines.

*Dryden.*

PROPÆDEUTICS, from *προαιδεω*, to prepare for instruction: a term used in Germany to indicate the knowledge which is necessary or useful for understanding or practising an art or science, or which unfolds its nature and extent, and the method of learning it. It is applied, therefore, not only to special introductions to particular branches of study, but also to auxiliary sciences, logic, philology, &c., and the encyclopædic views of particular branches of science which facilitate an insight into the relations of the parts. Such a survey can be presented only by one who has studied a science in all its ramifications. The term *propædeutics* is often, of course, merely relative; thus philology belongs to the propædeutics of history, while it is itself the main study of a certain class of scholars. The term, however, in its common use, is generally restricted to the body of knowledge, and of rules necessary for the study of some particular science—rules which originate in the application of the general laws of science or art to a particular department. Thus we find in the catalogues of lectures to be delivered in German universities, medical propædeutics, &c., enumerated.

PROPAGANDA; a name generally given to those institutions by which Christianity is propagated in heathen countries, more particularly to those which were established in the seventeenth century, and especially that erected by the papal court, for the extension of its own power and the Catholic religion among those who were not Christians or Catholics. It was called the *congregatio de propaganda fide* (society for propagating the faith), and was founded by Gregory XV. in 1622. It consisted of eighteen cardinals, and some papal ministers and officers of the college; and its object was, to arrange and direct all measures relating to the extension of the Catholic faith and the extirpation of heretics. Connected with this was the *collegium seu seminarium de propaganda fide*, instituted by Urban VIII. 1627, for the education of missionaries. Each Society meet once a week, in the presence of the pope, in a palace built for the purpose. Converts to the Catholic church, who had come to Rome, were instructed and

supported by them. Bishops, and other clergy who had been expelled, were also received and supported. The Roman propaganda had a press celebrated for the numerous works which issued from it. Thence breviaries and missals were sent to all parts. Missionary societies, for the propagation of the Christian religion, have been formed in Protestant countries on this model. (See *Missions.*) In the time of the French revolution, secret societies, whose object was the propagation of democratical principles, were called *propaganda*. *Propaganda* has, therefore, come to signify any kind of institution for making proselytes.

PROPAGATE, *v. a. & n. s.* Lat. *propago.*

PROPAGABLE, *adj.* } To continue by

PROPAGATION, *n. s.* } generation or

PROPAGATOR. } production; to

diffuse; extend; promote; transport; increase; to have offspring: propagable is, that may be propagated: propagation, the act of continuing or diffusing by successive production: propagator, corresponding in sense.

I have upon a high and pleasant hill  
Feigned fortune to be throned: the base o' the  
mount

Is ranked with all deserts, all kind of natures,  
That labour on the bosom of this spheru.  
To propagate their states. *Shakspeare. Timon.*

Some have thought the *propagating* of religion by  
arms not only lawful, but meritorious.

*Decay of Piety.*

All that I eat, or drink, or shall beget,  
Is *propagated* curse! *Milton's Paradise Lost.*

No need that thou  
Should'st *propagate*, already infinite,  
And through all numbers absolute, though one.  
*Milton.*

Is it an elder brother's duty so  
To *propagate* his family and name;  
You would not have yours die and buried with you?  
*Otway.*

From hills and dales the cheerful cries rebound,  
For echo hunts along, and *propagates* the sound.  
*Dryden.*

Old stakes of olive trees in plants revive,  
But nobler veins by *propagation* thrive. *Id.*

PROPEL, *v. a.* Lat. *propello.* To drive  
forward.

Avicen witnesses the blood to be frothy, that is  
*propelled* out of a vein of the breast. *Harvey.*

This motion, in some human creatures, may be  
weak in respect to the viscosity of what is taken, so  
as not to be able to *propel* it.

*Arbuthnot on Aliments.*

PROPEN'D, *v. n.* } Lat. *propendo*, to  
PROPEN'DENCY, *n. s.* } hang forwards. To  
incline to any part; be disposed in favor of any  
thing. Not used.

PROPENSE, *adj.* } Lat. *propensus.* In-  
PROPEN'SION, *n. s.* } clined; disposed; used  
PROPEN'SITY. } both of good and bad:  
propen-ity is tendency; particularly moral dis-  
position; natural tendency.

I have brought scandal  
In feeble hearts, *propense* enough before  
To waver, or fall off, and join with idols.  
*Milton.*

It requires a critical nicety to find out the genius or  
the *propensities* of a child. *L'Estrange.*

Let there be but *propensity*, and bent of will to religion, and there will be sedulity and indefatigable industry. *South.*

So forcible are our *propensions* to mutiny, that we equally take occasions from benefits or injuries.

*Government of the Tongue.*

He assists us with a measure of grace, sufficient to over-balance the corrupt *propensity* of the will.

*Rogers.*

This great attrition must produce a great *propensity* to the putrescent alkaline condition of the fluids.

*Arbuthnot.*

It is, however, not to be omitted, that he appears always *propense* towards the side of mercy. *Johnson.*

PROPER, *adj.*

PROPERLY, *adv.*

PROFERNESS, *n. s.*

PROPERTY, *n. s. & v. a.*

Fr. *propre*; Lat. *proprius*. Peculiar; natural; fit; adapted; belonging to an individual; one's own; literal; mere; pure; pretty or beautiful; and, in a low sense, tall; stout; the adverb and noun substantive corresponding: property is, peculiar quality; disposition, or right; possession held in one's own right; any thing promised; an appendage; any thing peculiarly new or adapted: to property is, to seize or retain as a right; to invest with qualities or possessions; but neither sense is now in use.

Moses was a *proper* child. *Hebrews xi. 23.*

Men of learning hold it for a slip in judgment, when offer is made to demonstrate that as *proper* to one thing, which reason findeth common unto many.

*Hooker.*

What special *property* or quality is that, which, being no where found but in sermons, maketh them effectual to save souls? *Id.*

The bloody book of law

You shall yourself read in the bitter letter, After your own sense; yea, though our *proper* son stood in your action. *Shakspeare. Othello.*

*Proper* deformity seems not in the fiend

So horrid as in woman. *Id. King Lear.*

At last she concluded with a sigh, thou wast the *properest* man in Italy. *Shakspeare.*

Here I disclaim all my paternal care,

Propinquity, and *property* of blood,

And, as a stranger to my heart and me,

Hold thee. *Id. King Lear.*

I will draw a bill of *properties*, such as our play wants. *Shakspeare.*

His reared arm

Crested the world; his voice was *propertied*

As all the tuned spheres.

*Id. Antony and Cleopatra.*

I am too highborn to be *propertied*,

To be a secondary at controul. *Shakspeare.*

Our poets excel in grandity and gravity, smoothness and *property*, in quickness and briefness.

*Camden.*

Of nought no creature ever formed ought,

For that is *proper* to the Almighty's hand.

*Davies.*

That conviction, not force, that must induce assent, and sure the logic of a conquering sword has no great *property* that way; silence it may, but convince it cannot. *Decay of Piety.*

In our *proper* motion we ascend

Up to our native seat. *Milton.*

What dies but what has life

And sin? the body *property* hath neither. *Id.*

If we might determine it, our *proper* conceptions would be all voted axioms. *Glanville's Sceptis.*

Court the age

With somewhat of your *proper* rage. *Waller.*

Now learn the difference at your *proper* cost, Betwixt true valour and an empty boast.

*Dryden.*

In Athens all was pleasure, mirth, and play,

All *proper* to the spring, and sprightly May. *Id.*

For numerous blessings yearly show'd,

And *property* with plenty crowned, *Id.*

Accept our pious praise.

The purple garments raise the lawyer's fees,

High pomp and state are useful *properties*. *Id.*

A *proper* goodly fox was carrying to execution.

*L'Estrange.*

Outward objects, that are extrinsecal to the mind and its own operations, proceeding from powers intrinsecal and *proper* to itself, which become also objects of its contemplation, are the original of all knowledge. *Locke.*

*Property*, whose original is from the right a man has to use any of the inferior creatures, for subsistence and comfort, is for the sole advantage of the proprietor, so that he may even destroy the very thing that he has *property* in. *Id.*

They professed themselves servants of Jehovah, their God, in a relation and respect peculiar and *proper* to themselves. *Nelson.*

Those parts of nature, into which the chaos was divided, they signified by dark names, which we have expressed in their plain and *proper* terms.

*Burnet's Theory of the Earth.*

There is a sense in which the works of every man, good as well as bad, are *property* his own.

*Rogers.*

In debility, from great loss of blood, wine, and all aliment that is easily assimilated or turned into blood, are *proper*; for blood is required to make blood. *Arbuthnot.*

Greenfield was the name of the *property* man in that time, who furnished implements for the actors. *Pope.*

The miseries of life are not *property* owing to the unequal distribution of things. *Swift.*

No wonder such men are true to a government, where liberty runs so high, where *property* is so well secured. *Id.*

A *proper* name may become common, when given to several beings of the same kind; as Cæsar. *Watts.*

A secondary essential mode is any attribute of a thing, which is not of primary consideration, and is called a *property*. *Id.*

PROPERTIUS (Sextus Aurelius), a celebrated Latin poet, born at Mevania, a city of Umbria. He went to Rome after the death of his father, a Roman knight, who had been put to death by order of Augustus, for having followed Antony's party. Propertius acquired great reputation by his abilities, and was patronised by Mæcenas and Cornelius Gallus. He had also Ovid, Tibullus, and other literati of his time, for his friends. He died in Rome 19 B. C. His four books of elegies are printed with almost all the editions of Tibullus and Catullus; the best is the separate edition by J. Brouckhusius at Amsterdam, 1702 and 1714, 4to.

PROPERTY. See LAW.

PROPHETCY, *n. s.*

PROPH'ET,

PROPH'ESY, *v. a. & v. n.*

PROPH'ETESS, *n. s.*

PROPH'ETIC, *adj.*

PROPH'ETICAL,

PROPH'ETICALLY, *adv.*

PROPH'ETIZE, *v. n.*

Fr. *prophete*; Ital. *profeta*; Span. Port. and Lat. *propheta*. Gr. *προφητης*. One who predicts or foretels future events; one who teaches or preacns a prophecy

is a prediction; declaration of something future: to prophesy, to foretel; prognosticate; foreshow; utter predictions; preach: prophetize, an obsolete synonyme: prophetess, the feminine of prophet: prophetic and prophetical, of the nature of prophecy; the adverb corresponding.

I hate him, for he doth not prophesy good, but evil.

1 Kings.

The elders of the Jews builded, and prospered through the prophesying of Haggai.

Extra vi. 14.

He hearkens after propheties and dreams.

Shakspeare.

Miserable England,

I prophesy the fearful'st time to thee,

That ever wretched age hath looked upon.

Methought thy very gait did prophesy

A royal nobleness.

Id. King Lear.

His champions are the prophets and apostles.

Shakspeare.

He shall split thy very heart with sorrow,

And say poor Marg'ret was a prophetess.

Id.

He is so prophetically proud of an heroic cudgeling, that he raves in saying nothing.

Id.

Some perfumes procure propheticall dreams.

Bacon.

The counsel of a wise and then propheticall friend was forgotten.

Wotton.

That it is consonant to the word of God, so in singing to answer, the practice of Miriam the prophetess, when she answered the men in her song, will approve.

Peacham.

It buildeth her faith and religion upon the sacred and canonical scriptures of the holy prophets and apostles, as upon her main and prime foundation.

White.

Nature else hath conference

With profound sleep, and so doth warning send

By prophetizing dreams.

Daniel's Civil War.

This great success among Jews and Gentiles, part of it historically true at the compiling of these articles, and part of it prophetically true then, and fulfilled afterward, was a most effectual argument to give authority to this faith.

Hammond.

O prophet of glad tidings! finisher

Of utmost hope!

Milton.

Till old experience do attain

To something like prophetic strain.

Id.

Poets may boast

Their work shall with the world remain;

Both bound together, live or die,

The verses and the prophesy.

Waller.

Some famous prophetic pictures represent the fate of England by a mole, a creature blind and busy, smooth and deceitful, continually working under ground, but now and then to be discerned in the surface.

Stillingfleet.

He loved so fast,

As if he feared each day would be her last,

Too true a prophet to foresee the fate,

That should so soon divide their happy state.

Dryden.

The more I know, the more my fears augment, And fears are oft prophetic of the event.

Id.

She sighed, and thus prophetically spoke.

Id.

God, when he makes the prophet, does not unmake the man.

Locke.

No arguments made a stronger impression on these Pagan converts, than the predictions relating to our Saviour in those old prophetic writings deposited among the hands of the greatest enemies to Christianity, and owned by them to have been extant many ages before his appearance.

Addison.

If my love at once were crowned,

Fair prophetess, my grief would cease.

Prior.

It was attested by the visible centering of all the old propheties in the person of Christ, and by the completion of these propheties since, which he himself uttered.

Atterbury.

Received by thee, I prophesy, my rhimes, Mixed with thy works, their life no bounds shall see.

Tickel.

Pleasure is deaf when told of future pain,

And sounds prophetic are too rough to suit

Ears long accustomed to the pleasing lute.

Cowper

False prophetess! the day of change was come;

Behind the shadow of eternity,

He saw his visions set of earthly fame,

For ever set.

Pollak.

PROPHECY. The propheties in the Scriptures, upon which, if room permitted, we might enlarge, afford the most decisive evidence of the truth of Christianity, being in fact a kind of standing miracles, that have existed for ages, and still exist, in proof of the veracity of Scripture. We may specify, I. The prophecy of Noah (Gen. ix. 25, 26), respecting the degraded and enslaved state of the posterity of Ham; fulfilled, first by the Jews in the slavery of the Canaanites; afterwards by the Greeks in the destruction of Tyre, and by the Romans in that of Carthage; and, in modern times, in the oppression of their posterity by the Saracens and Turks, and even to the present age by the slave trade. II. The prophecy of the innumerable posterity of Abraham; but more particularly of the wild, predatory, free, and independent state of his posterity by Ishmael (Gen. xvi. 10—12.), fulfilled in all ages, as well as in the present, by the unconquered state of the Arabs. III. The remarkable prophecy of Moses (Deut. xxviii. 64—66) and of Hosea (iii. 4) against the Jews, which have been so literally fulfilled for upwards of 1800 years past; notwithstanding which, while they have been scattered among all the nations on the globe, they continue still a distinct people, firmly and irrevocably attached to their peculiar customs, though persecuted every where on that account. This is a phenomenon unparalleled in the history of mankind, and totally unaccountable upon the ordinary principles of human action; and therefore only accountable upon the principle of their being still preserved a distinct people, till the period when they shall fulfil the remaining part of Hosea's prediction (iii. 26). IV. To these remarkable propheties, we might add those of Daniel, respecting the four universal monarchies; and those of St. Paul and St. John, which so clearly foretel the various fortunes of the Christian church; with its progress from the age of apostolic purity, to that state of universal corruption under which it sunk for about 1000 years, together with its gradual restoration to purity. But, for further information on all these subjects, we must refer the reader to bishop Newton's Dissertations on the Propheties; bishop Chandler's Vindication of Christianity; bishop Hurd's Warburtonian Lecture; bishop Sherlock's Discourses on Prophecy, &c. See THEOLOGY.

PROPHETS, among the Jews, were persons commissioned and inspired by God to declare his will and purposes to that people. Previous to the existence of that nation, there were other inspired prophets, particularly Enoch, Lamech,

of Noah. After the deluge, and before the giving of the law, we find Melchizedek, Abraham, Isaac, Jacob, Joseph, Job, Elihu, and Moses. Under the law, we find several eminent prophets; particularly Joshua, Samuel, Gad, Nathan, Ahijah, Elisha, Micaiah, and some others whose names are not recorded; and, among the prophetic books of the Old Testament, are preserved the writings of sixteen prophets, who are commonly styled the greater and lesser.

**THE GREATER PROPHETS**, so called from the number and extent of their writings, are four, viz. ISAIAH, JEREMIAH, EZEKIEL, and DANIEL.

**THE LESSER PROPHETS**, so named from the brevity of their prophecies, are twelve; viz. HOSEA, JOEL, AMOS, OBADIAH, JONAH, MICAH, NAHUM, HABAKKUK, ZEPHANIAH, HAGGAI, ZECHARIAH, and MALACHI. See these articles in their order.

**PROPHETS, SONS OF THE**, in Scripture history, a denomination given to young men who were educated under a proper master, (who was commonly, if not always, an inspired prophet,) in the knowledge of religion and in sacred music, and who were qualified to be public teachers. This seems to have been part of the business of the prophets on the Sabbath days and festivals.

**PROPHYLACTIC**, *adj.* Gr. *προφυλακτικός*, *προφυλασσω*. Preventive; preservative.

Medicine is distributed into *prophylactic*, or the art of preserving health; and therapeutic, or the art of restoring health. *Watts.*

**PROPINQUITY**, *n. s.* Lat. *propinquitās*. Nearness; proximity of station, kind, time, or place.

Here I disclaim all my paternal care,  
Propinquity, and property of blood,  
And, as a stranger to my heart and me,  
Hold thee. *Shakspeare. King Lear.*

Thereby was declared the propinquity of their deceptions, and that their tranquillity was of no longer duration, than those soon decayed fruits of summer. *Broune.*

They draw the retina nearer to the crystalline humor, and by their relaxation suffer it to return to its natural distance according to the exigency of the object, in respect of distance or propinquity. *Roy.*

**PROPTIATE**, *v. a.* Lat. *propitio*.  
**PROPTIABLE**, *adj.* To conciliate;  
**PROPTIATION**, *n. s.* gain; induce to  
**PROPTIATOR**, favor; appease;  
**PROPTIATORY**, *adj. & n. s.* make gracious;  
**PROPTIOUS**, propitiably, appeasable; such  
**PROPTIOUSLY**, *adv.* as may be induced  
**PROPTIOUSNESS**, *n. s.* to favor: propitiation is, the act or means of  
 conciliation; atonement made: propitiator, he  
 who makes it: propitiatory, having the power to  
 conciliate; as a noun substantive, a mercy-seat,  
 or throne of mercy: propitious, favorable; kind;  
 gracious; partial: the adverb and noun sub-  
 stantive corresponding.

He is the propitiation for the sins of the whole world. *1 John.*

'T assuage the force of this new flame,  
And make thee more propitious in my need,  
I mean to sing the praises of thy name. *Spenser.*

Let not my words offend thee,  
My Maker, be propitious, while I speak! *Milton.*

So when a muse propitiously invites,  
Improve her favours, and indulge her flights. *Roscommon.*

You, her priest, declare  
What offerings may propitiate the fair,  
Rich orient pearl, bright stones that ne'er decay,  
Or polished lines which longer last than they. *Waller.*

Is not this more than giving God thanks for their virtues, when a propitiatory sacrifice is offered for their honour? *Stillingfleet.*

All these joined with the propitiousness of climate to that sort of tree and the length of age it shall stand and grow, may produce an oak. *Temple.*

Vengeance shall pursue the inhuman coast,  
Till they propitiate thy offended ghost. *Dryden.*

Would but thy sister Marcia be propitious  
To thy friend's vows. *Addison's Cato.*

Ere Phœbus rose he had implored  
Propitious Heaven. *Pope's Rape of the Lock.*

Let fierce Achilles, dreadful in his rage,  
The god propitiate, and the pest assuage. *Pope.*

In allusion to the ancient worship, the apostle represents Christ as a propitiatory or mercy-seat, set forth by God for receiving the worship of men, and dispensing pardon to them. *Macknight.*

**PROPTIATION**. Among the Jews there were both ordinary and public sacrifices, as holocausts, &c., offered by way of thanksgiving; and extraordinary ones, offered by particular persons guilty of any crime, by way of propitiation. The Roman Catholics believe the mass to be a sacrifice of propitiation for the living and the dead. The reformed churches allow of no propitiation but that one offered by Jesus Christ on the cross.

**PROPTIATORY**, any thing rendering God propitious; as propitiatory sacrifices, in contradistinction to eucharistical. Among the Jews the propitiatory was the cover or lid of the ark of the covenant; which was lined both within and without with plates of gold, inasmuch that there was no wood to be seen. This propitiatory was a type or figure of Christ, whom St. Paul calls the propitiatory ordained from all ages.

**PROPLASM**, *n. s.* Gr. *προ* and *πλάσμα*. Mould; matrix.

Those shells serving as *proplasm*s or moulds to the matter which so filled them, limited and determined its dimensions and figure. *Woodward.*

**PROPONENT**, *n. s.* Lat. *proponens*. One that makes a proposal, or lays down a position.

For mysterious things of faith rely  
On the proponent, heaven's authority. *Dryden.*

**PROPONTIS**, or the Sea of Marmora, a part of the Mediterranean, dividing Europe from Asia; it has the Hellespont or canal of the Dardanelles on the south-west, whereby it communicates with the Archipelago, and the ancient Bosphorus of Thrace, or Straits of Constantinople, on a north-east, communicating with the Black or Euxine Sea. It has two castles; that on the side of Asia is on a cape, where formerly stood a temple of Jupiter; that of Europe is on the opposite cape, and had anciently a temple of Serapis. It is 120 miles long, and in some places upwards of forty miles broad. Lempriere says, 'it is 175 miles long, and sixty-two broad;' and that 'it received its name from its vicinity to Pontus.'—Class Dict.

**PROPORTION**, *n. s. & v. a.* } Fr. *proportion*; Latin, *proportio*.  
**PROPORTIONABLE**, *adj.* } Ratio: comparative relation; settled relation or graduation;  
**PROPORTIONABLY**, *adv.* }  
**PROPORTIONAL**, *adj.* }  
**PROPORTIONALITY**, *n. s.* }  
**PROPORTIONALLY**, *adv.* }  
**PROPORTIONATE**, *adj. & v. a.* }  
**PROPORTIONATENESS**, *n. s.* }  
 symmetry; harmonic agreement; form; size: to adjust; form symmetrically: proportionable, proportional, and proportionate, mean, having a settled comparative relation; suitable; the adverbs corresponding: proportionality and proportionateness, the state of being proportionate, or comparatively adjusted.

Nature had *proportioned* her without any fault, quickly to be discovered by the senses; yet altogether seemed not to make up that harmony that Cupid delights in. *Sidney.*

Measure is that which perfecteth all things, because every thing is for some end; neither can that thing be available to any end which is not *proportionable* thereunto: and to *proportion* as well excesses as defects are opposite. *Hooker.*

Let any man's wisdom determine by lessening the territory, and increasing the number of inhabitants, what *proportion* is requisite to the peopling of a region in such a manner that the land shall be neither too narrow for those whom it feedeth, nor capable of a greater multitude. *Raleigh.*

It is good discretion not to make too much of any man at the first; because one cannot hold out that *proportion*. *Lord Bacon.*

All things received, do such *proportions* take,  
 As those things have, wherein they are received;

So little glasses little faces make,  
 And narrow webs on narrow frames are weaved. *Davies.*

By *proportion* to these rules, we may judge of the obligation that lies upon all sorts of injurious persons. *Taylor.*

His volant touch  
 Instinct through all *proportions*, low and high,  
 Fleed, and pursued transverse the resonant fugue. *Milton.*

It must be mutual in *proportion* due  
 Given and received. *Id.*

The serpent lives,  
 Lives, as thou said'st, and gains to live as man  
 Higher degree of life, inducement strong  
 To us, as likely tasting to attain  
*Proportional* assent, which cannot be  
 But to be gods or angels. *Id. Paradise Lost.*

By this congruity of those faculties to their proper objects, and by the fitness and *proportionateness* of these objective impressions upon their respective faculties accommodated to their reception, the sensible nature hath so much of perception, as is necessary for its sensible being. *Hale.*

Four numbers are said to be *proportional*, when the first containeth, or is contained by the second, as often as the third containeth, or is contained by the fourth. *Cocker.*

The parallelism and due *proportionated* inclination of the axis of the earth. *More's Divine Dialogues.*

His commandments are not grievous, because he offers us an assistance *proportionable* to the difficulty. *Tillotson.*

No man of the present age is equal in the strength, *proportion*, and knitting of his limbs, to the Hercules of Farnese. *Dryden.*

Greater visible good does not always raise men's desires, in *proportion* to the greatness it is acknow-

ledged to have, though every little trouble sets us on work to get rid of it. *Locke.*

The mind ought to examine all the grounds of probability, and, upon a due balancing the whole, reject or receive it *proportionably* to the preponderancy of the greater grounds of probability, on one side or the other. *Id.*

The connection between the end and any means is adequate, but between the end and means *proportionate*. *Grew.*

All sense, as grateful, dependeth upon the equality or the *proportionability* of the motion or impression made. *Id.*

In *proportion* as this resolution grew, the terrors before us seemed to vanish. *Tatler.*

The *proportions* are so well observed that nothing appears to an advantage, or distinguishes itself above the rest. *Addison.*

In the loss of an object, we do not *proportion* our grief to the real value it bears, but to the value our fancies set upon it. *Id.*

It was enlivened with an hundred and twenty trumpets, assisted with a *proportionable* number of other instruments. *Id.*

Things nigh equivalent and neighbouring value By lot are parted; but high heaven thy share,  
 In equal balance weighed 'gainst earth and hell,  
 Flings up the adverse scale, and shuns *proportion*. *Prior.*

If light be swifter in bodies than in vacuo, in the *proportion* the sines of which measure the refraction of the bodies, the forces of the bodies to reflect and refract light, are very nearly *proportional* to the densities of the same bodies. *Newton.*

The parts of a great thing are great, and there are *proportionably* large estates in a large country. *Arbuthnot.*

Since every single particle hath an innate gravitation toward all others, *proportionated* by matter and distance, it evidently appears that the outward atoms of the chaos would necessarily tend inwards, and descend from all quarters towards the middle of the whole space. *Bentley's Sermons.*

Harmony, with every grace,  
 Plays in the fair *proportions* of her face. *Mrs. Carter.*

Hast thou incurred  
 His anger, who can waste thee with a word,  
 Who poises and *proportions* sea and land,  
 Weighing them in the hollow of his hand,  
 And in whose sight all nations seem  
 As grasshoppers, as dust, a drop, a dream? *Cooper.*

**PROPORTION**, the identity or similitude of two ratios. Hence quantities that have the same ratio between them are said to be proportional; e. gr. if A be to B as C to D, or 8 be to 4 as 30 to 15; A, B, C, D, and 8, 4, 30, and 15, are said to be in proportion, or are simply called proportionals. Proportion is frequently confounded with ratio, yet the two convey in reality very different ideas, which ought by all means to be distinguished. Ratio is properly that relation or habitude of two things which determines the quantity of one from the quantity of another, without the intervention of any third; thus we say the ratio of 5 and 10 is 2, the ratio of 12 and 24 is 2. Proportion is the sameness or likeness of two such relations; thus the relations between 5 and 10 and 12 and 24 being the same, or equal, the four terms are said to be in proportion. Hence ratio exists between two numbers but proportion requires at least three.

**PROPORTION** is also used for the relation between unequal parts of the same kind, whereby their several parts correspond to each other with an equal augmentation or diminution.

**PROPORTION**, in architecture, denotes the just magnitude of the members of each part of a building, and the relation of the several parts to the whole; e. gr. of the dimensions of a column, &c., with regard to the ordonnance of a whole building.

**PROPOSE**, *v. a. & v. n.* } Ital. *proporre* ;  
**PROPOSAL**, *n. s.* } Span. *proponer* ;  
**PROPOSER**, } Fr. *proposer* ; Lat.  
**PROPOSITION**, } *propono*. To submit to consideration;  
**PROPOSITIONAL**, *adj.* } offer to the mind : the proposer, he who forms or offers a proposal or scheme : proposition, one of the three logical parts of an argument ; a sentence which affirms or denies any thing ; offer : the adjective corresponding.

Run thee into the parlour,  
 There shalt thou find my cousin Beatrice,  
*Proposing* with the prince and Claudio.

The first *proposition* of the precedent argument is not necessary. *White.*

Chryssippus, labouring how to reconcile these two *propositions*, that all things are done by fate, and yet that something is in our own power, cannot extricate himself. *Hammond.*

The enemy sent *propositions*, such as upon delivery of a strong fortified town, after a handsome delivery, are usually granted. *Clarendon.*

Raphael to Adam's doubt *proposed*,  
 Benevolent and facile thus replied. *Milton.*  
 The compounding the representation of things, with an affirmation or negation, makes a *proposition*. *Hale.*

Faith is the assent to any *proposition*, not made out by the deductions of reason, but upon the credit of the *proposer*, as coming from God. *Locke.*

My design is to treat only of those who have chiefly *proposed* to themselves the principal reward of their labours. *Tatler.*

Upon the *proposal* of an agreeable object, a man's choice will rather incline him to accept than refuse it. *South.*

The work you mention will sufficiently recommend itself, when your name appears with the *proposals*. *Addison to Pope.*

This truth is not likely to be entertained readily upon the first *proposal*. *Atterbury.*

He provided a statute, that, whoever *proposed* any alteration to be made, should do it with a rope about his neck : if the matter *proposed* were generally approved, then it should pass into a law ; if it went in the negative, the *proposer* to be immediately hanged. *Swift.*

In learning any thing there should be as little as possible first *proposed* to the mind at once, and, that being understood, proceed then to the next adjoining part. *Watts.*

If it has a singular subject in its *propositional* sense, it is always ranked with universals. *Id.*

**PROPOSITION**, in logic, part of an argument wherein some quality, either negative or positive, is attributed to a subject.

**PROPOSITION**, in mathematics, is either some truth advanced and shown to be such by demonstration or some operation proposed and its so-

lution shown. If the proposition be deduced from several theoretical definitions compared together, it is called a theorem ; if from a praxis, or series of operations, it is called a problem.

**PROPOUND**, *v. n.* } Lat. *propono*. To  
**PROPOUNDER** } offer to consideration ;  
 propose : he who proposes any thing.

A spirit raised from depth of under-ground,  
 That shall make answer to such questions,  
 As by your grace shall be *propounded* him.

*Shakspeare.*  
 A king, when he presides in council, let him beware how he opens his own inclination too much in that which he *propoundeth* ; for else counsellors will but take the wind of him, and, instead of giving free counsel, will sing him a song of placebo. *Bacon.*

To leave as little as I may unto fancy, which is wild and irregular, I will *propound* a rule. *Watton.*

The parliament, which now is held, decreed  
 Whatever pleased the king but to *propound*.

Dar'st thou to the Son of God *propound*  
 To worship thee ? *Milton.*

The existence of the church hath been *propounded* as an object of our faith in every age of Christianity. *Pearson.*

The arguments which Christianity *propounds* to us are reasonable encouragements to bear sufferings patiently. *Tillotson.*

**PROPRETOR**, a Roman magistrate, who, having discharged the office of pretor at home, was sent into a province to command there with his former pretorial authority. It was also an appellation given to those who, without having been pretors at Rome, were sent extraordinarily into the provinces to administer justice, with the authority of pretors.

**PROPRIETY**, *n. s.* } Fr. *propriété*,  
**PROPRIETARY**, *n. s. & adj.* } *propriétaire* ;  
**PROPRIETOR**, *n. s.* } Lat. *proprietas*.  
**PROPRIETRESS**. } Peculiar possession or right ; hence accuracy ; justness ; correctness of behaviour : a proprietary is a possessor in his own right ; the adjective means belonging of right to a certain owner : proprietor, an owner ; possessor in his own right : proprietress, the feminine of that noun.

You must have promised to yourselves *propriety* in love,  
 Know women's hearts like straws do move.

Benefit of peace, and vacation for piety, render it necessary by laws to secure *propriety*. *Hammond.*

Hail, wedded love ! mysterious law, true source  
 Of human offspring, sole *propriety*  
 In Paradise ! of all things common else. *Milton.*

They secure *propriety* and peace. *Dryden.*  
 A big-bellied bitch borrowed another bitch's kennel to lay her burden in ; the *proprietress* demanded possession, but the other begged her excuse.

*L'Estrange.*  
 Man, by being master of himself, and *proprietor* of his own person, and the actions or labour of it, had still in himself the great foundation of *propriety*. *Locke.*

Common use, that is the rule of *propriety*, affords some aid to settle the signification of language. *Id.*

Though sheep, which are *proprietary*, are seldom marked, yet they are not apt to straggle. *Grew.*

'Tis a mistake to think ourselves stewards in some of God's gifts, and *proprietaries* in others : they are



all equally to be employed, according to the designation of the donor. *Government of the Tongue.*

**PROPUGN'** *v. a.* } Lat. *propugno.* To  
**PROPUGNATION, n. s.** } defend; vindicate:  
**PROPUGNER.** } defence: he who defends.

Thankfulness is our meet tribute to those sacred champions for *propugning* of our faith. *Hammond.*

**PROPULSION, n. s.** Lat. *propulsus.* The act of driving forward.

Joy worketh by *propulsion* of the moisture of the brain, when the spirits dilate and occupy more room. *Bacon.*

**PROPYLÆA** (Greek *προπυλαία*); the splendid entrance to a temple among the Greeks, a square before the temple, surrounded with a portico; on the square in the open air stood the altar. The term was employed particularly in speaking of the superb vestibules, or porticoes, conducting to the Acropolis, or citadel of Athens, which formed one of the principal ornaments of the city. This magnificent work, of the Doric order, was constructed by Pericles, after the designs of Mnesicles, one of the most celebrated architects of his age. Pausanias says it was covered with white marble, remarkable for the size of the blocks and the beauty of the workmanship. Stewart, in his *Antiquities of Athens*, Le Roy, in his ruins of Greece, and the Travels of Anacharsis the Younger, mention the relics of the *propylæa*.

**PRORE, n. s.** Lat. *prora.* The prow; the forepart of the ship. A poetical word, used for a rhyme.

There no vessel with vermilion *prore*,  
Or bark of traffic, glides from shore to shore. *Pope.*

**PROROGUE, v. a.** } Fr. *proroger*; Latin  
**PROROGATION, n. s.** } *prorogo.* To protract;  
prolong; put off; in a particular sense withhold the sitting of parliament: the noun substantive corresponding.

My life was better ended by their hate,  
Than death *prorogued*, wanting of thy love. *Shakespeare.*

By the king's authority alone they are assembled, and by him alone are they *prorogued* and dissolved; but each house may adjourn itself. *Baron.*

He *prorogued* his government, still threatening to dismiss himself from public cares. *Dryden.*

The fulness and effluence of man's enjoyments, in the state of innocence, might seem to leave no place for hope, in respect of any farther addition, but only of the *prorogation* and future continuance of what already he possessed. *South.*

It would seem extraordinary, if an inferior court should take a matter out of the hands of the high court of parliament, during a *prorogation.* *Swift.*

But Savage easily reconciled himself to mankind without imputing any defect to his work, by observing that his poem was unluckily published two days after the *prorogation* of parliament. *Johnson.*

**PROROGATION** differs from an adjournment of parliament in this, that by prorogation the session is ended, and such bills as passed in either house, or both houses, and had not the royal assent, must at the next assembly begin again.

**PRORUPTION, n. s.** Lat. *proruptus, prorumpo.* The act of bursting out.

Others ground this disruption upon their continued or protracted time of delivery, whereat, excluding

but one a day, the latter brood, impatient, by a forcible *prorruption*, anticipate their period of exclusion.

*Browne's Vulgar Errors.*

**PROSCRIBE, v. a.** } Latin *proscribo.* To  
**PROSCRIBER, n. s.** } censure capitally; de-  
**PROSCRIPTION.** } crete to death or destruction: the proscriber is he who makes or issues such a decree: proscription, the decree issued.

Robert Vere, earl of Oxford, through the malice of the peers, was banished the realm, and *proscribed.* *Spenser.*

You took his voice who should be prickt to die,  
In our black sentence and *proscription.* *Shakespeare.*  
For the title of *proscription* or forfeiture, the emperor hath been judge and party, and justified himself. *Bacon.*

I hid for thee  
Thy murder of thy brother, being so bribed,  
And writ him in the list of my *proscribed*  
After thy fact. *Ben Jonson.*

Sylla's old troops  
Are needy and poor; and have but left t' expect  
From Catiline new bills and new *proscriptions.* *Id.*

Followed and pointed at by fools and boys,  
But dreaded and *proscribed* by men of sense. *Roscommon.*

He shall be found,  
And taken or *proscribed* this happy ground. *Dryden.*

The triumvir and *proscriber* had descended to us  
in a more hideous form, if the emperor had not  
taken care to make friends of Virgil and Horace. *Id.*

Some utterly *proscribe* the name of chance, as a word of impious and profane signification; and, indeed, if taken by us in that sense in which it was used by the heathens, so as to make any thing casual, in respect of God himself, their exception ought justly to be admitted. *South.*

In the year 325, as is well known, the Arian doctrines were *proscribed* and anathematized in the famous council of Nice, consisting of 318 bishops, very unanimous in their resolutions, excepting a few reclaimants. *Waterland.*

That he who dares, when she forbids, be grave,  
Shall stand *proscribed*, a madman or a knave,  
A close designer not to be believed,  
Or, if excused that charge, at least deceived. *Cowper.*

**PROSE, n. s.** } Fr. *prose*; Lat. *prosa.* Lan-  
**PROSAIC, adj.** } guage not restrained to harmonic sounds or numbers; discourse not metrical: prosaic, the corresponding adiective.

Things unattempted yet in *prose* or rhyme. *Milton.*

The reformation of *prose* was owing to Boccace, who is the standard of purity in the Italian tongue, though many of his phrases are become obsolete. *Dryden.*

A poet lets you into the knowledge of a device better than a *prose* writer, as his descriptions are often more diffuse. *Addison.*

*Prose* men alone for private ends,  
I thought, forsook their ancient friends. *Prior.*

My head and heart thus flowing through my quill,  
Verse man and *prose* man, term me which you will. *Pope.*

I will be still your friend in *prose*:  
Esteem and friendship to express,  
Will not require poetic dress. *Swift*

**PROSECUTE**, *v. a.* } *Lat. prosequor, pro-*  
**PROSECUTION**, *n. s.* } *secutus.* To pursue;  
**PROSECUTOR**. } persevere in endeavors  
 after any thing; continue; proceed; particu-  
 larly, to proceed by legal measures: prosecution  
 is, pursuit; continuance of design or effort;  
 legal suit: prosecutor, he who pursues or prosecutes  
 legally or otherwise.

An infinite labour to *prosecute* those things, so far  
 as they might be exemplified in religious and civil  
 actions. *Hocker.*

I am beloved of beautiful Hermia;  
 Why should not I then *prosecute* my right?

*Shakspeare.*

The same reasons, which induced you to entertain  
 this war, will induce you also to *prosecute* the same.

*Hayward.*

All resolute to *prosecute* their ire,  
 Seeking their own and country's cause to free.

*Daniel.*

That which is morally good is to be desired and  
*prosecuted*; that which is evil is to be avoided.

*Wilkins.*

He infested Oxford, which gave them the more  
 reason to *prosecute* the fortifications. *Clarendon.*

I must not omit a father's timely care,  
 To *prosecute* the means of thy deliverance  
 By ransom. *Milton's Agonistes.*

With louder cries

She *prosecutes* her griefs, and thus replies.

*Dryden.*

He *prosecuted* this purpose with strength of argu-  
 ment and close reasoning, without incoherent sallies.

*Locke.*

Many offer at the effects of friendship, but they  
 do not last: they are promising in the beginning,  
 but they fail, jade, and tire in the *prosecution*.

*South.*

Their jealousy of the British power, as well as  
 their *prosecutions* of commerce and pursuits of uni-  
 versal monarchy, will fix them in their aversions to-  
 wards us. *Addison.*

**PROSECUTION.** See LAW.

**PROSELYTE**, *n. s. & v. a.* Fr. *proslite*;  
 Gr. *προσλυτης*. A convert; one brought over  
 to a new opinion; to convert.

Ye compass sea and land to make one *proselyte*.

*Matthew.*

Never any Pharisee was so eager to make a *prose-*  
*lyte*, as our late factors of Rome. *Hall.*

He that saw hell in's melancholy dream,

Scared from his sins, repented in a fright,

Had he viewed Scotland, and turned *proselyte*.

*Cleveland.*

Where'er you tread,

Millions of *proselytes* behind are led,

Through crowds of new-made converts still you go.

*Granville.*

Men become professors and combatants for those  
 opinions they were never convinced of, nor *proselytes*  
 to. *Locke.*

What numbers of *proselytes* may we not expect?

*Addison.*

Men of this temper cut themselves off from the  
 opportunities of *proselyting* others, by averting their  
 eyes from their company. *Government of the Tongue.*

**PROSELYTE**, in theology, is used to denote any  
 new convert. The term was frequent in the primi-  
 tive church; and the Jews likewise had their  
*proselytes*, who from Gentiles became Jews, fol-  
 lowing the precepts of the Mosaic law. It is  
 generally believed that among the Hebrews there  
 were two kinds of *proselytes*; one called *prose-*

*lytes* of righteousness, or *proselytes* of the cove-  
 nant, who became complete Jews, by submitting  
 to the rite of circumcision, and were in all re-  
 spects united to the Jewish church and nation.  
 The other called *proselytes* of the gate, who did  
 not embrace the Jewish religion, so as to be  
 obliged to receive or observe the ceremonial law,  
 and yet were suffered to live among the Jews  
 under certain restrictions; as that they should  
 not practice idolatry, nor worship any other god  
 beside the God of Israel; that they should not  
 blaspheme the God of Israel; that they should  
 keep the Jewish sabbath, so far at least as to re-  
 frain from working on that day. Besides forsak-  
 ing idolatry, they were under an obligation to  
 observe the seven precepts, which, as the Tal-  
 mudists pretend, God gave to Adam, and after-  
 wards to Noah, who transmitted them to posterity.  
 The first of these precepts forbids idolatry, and  
 the worship of the stars in particular; the second  
 recommends the fear of God; the third forbids  
 murder; the fourth adultery; the fifth theft; the  
 sixth enjoins respect and veneration for magis-  
 trates; and the seventh condemns eating of flesh  
 with the blood.

Dr. Lardner, with whom Dr. Doddridge and  
 others also agree, is of opinion that there was  
 but one sort of *proselytes* among the Jews. They  
 were circumcised, and thus they became Jews  
 by religion, and were permitted to eat the pass-  
 over, and to partake of all religious privileges,  
 as the Jews by descent did. They were called  
 'strangers, or *proselytes* within the gates, and  
 sojourners,' as they were allowed to dwell or  
 sojourn among the people of Israel. And they  
 were so called, because, according to the law  
 of Moses, they could not possess land. This is  
 the sense of the word in all the texts of the New  
 Testament where it is used. Dr. Lardner thinks  
 that the notion of two kinds of Jewish *proselytes*  
 cannot be found in any Christian writer before  
 the fourteenth century or later. This learned  
 writer pays no regard to what the later Jewish  
 rabbins say of the method of initiating *proselytes*  
 by circumcision, baptism, and sacrifice. See  
 Lardner's works, and Doddridge on the Acts.

**PROSELYTE BAPTISM.** The Jews (see our ar-  
 ticle BAPTISM) are said from an early period to  
 have practised the baptism of all their *proselytes*  
 from the heathen. We have given the ingenious  
 parallelism that has been drawn by some writers  
 between that supposed custom and Christian  
 baptism: the most modern and respectable au-  
 thors, we may add, continue to quote the con-  
 stant practice, as it has been called, of the Jews  
 in this matter 'before our Saviour's time, as the  
 foundation of infant baptism.' The editor of the  
 last edition of Dr. Gale's Reply to Dr. Wall  
 wholly disputes, however, the validity of this  
 argument, and insists that no foundation can be  
 found for it in authentic history. As we have  
 not met elsewhere with so detailed an examina-  
 tion of the authorities commonly referred to, we  
 subjoin his remarks on those of Dr. Wall's In-  
 troduction.

Dr. Wall, as this writer concedes, has rested  
 on the authority of some considerable names.  
 That is, he has transferred from the pages of  
 Ainsworth, Hammond, Lightfoot, &c., what they

state to be found in 'the books of the Jews,' without appearing to have consulted the original authorities; 'partly,' as he states, 'because the quotations for that purpose are to be searched for in books with which I am not so well acquainted; and partly because those few which I shall produce will make it clear enough that there was such a custom.' He repeatedly presses the importance of establishing this custom in the controversy with Antipædobaptists. 'The apostles must know that baptism was usually given to infants.' They would conceive the command to proselyte and baptize all nations to include infants as a matter of course; Christ 'took into his hands baptism,' says he, after Lightfoot, 'such as he found it, adding with this, that he exalted it to a nobler purpose and to a larger use;'—and after Hammond, that 'The whole nation knew well enough that infants were wont to be baptized. There was no need of a precept for that which was always settled by common use. Suppose there should at this time come out a proclamation in these words, Every one on the Lord's Day shall repair to the public assembly in the church: that man would reason weakly who should conclude that there were no prayers, sermons, psalms, &c., in the public assemblies on the Lord's Day, for this reason, because there was no mention of them in this proclamation; for the proclamation ordered the keeping of the Lord's Day in the public assemblies in general; and there was no need that mention should be made of the particular kinds of divine worship there to be used, since they were, both before and at the time of the said proclamation, known to every body, and in common use. Just so the case stood as to baptism. Christ ordered it to be for a sacrament of the New Testament, by which all should be admitted to the profession of the gospel, as they were formerly to proselytism in the Jews' religion. The particular circumstances of it, as the manner of baptizing, the age of receiving it, which sex was capable of it, &c., had no need of being regulated or set down, because they were known to every body by common usage. It was, therefore, necessary, on the other side, that there should have been an express and plain order that infants and little children should not be baptized, if our Saviour had meant that they should not; for, since it was ordinary in all ages before to have infants baptized, if Christ would have had that usage to be abolished, he would have expressly forbidden it; so that his and the Scriptures' silence in this matter does confirm and establish infant baptism for ever.'

I. Dr. Wall's first position is, that it is evident 'the custom of the Jews before our Saviour's time (and as they themselves affirm from the beginning of their law) was to baptize as well as circumcise any proselyte that came over to them from the nations.' 'This custom of theirs, he says, 'is fully and largely set forth by Maimonides, Isura Bia, cap. xiii. and xiv;' from whom a long quotation states that the ancient Israelites entered into covenant with Jehovah by circumcision, dipping, and sacrifice; that in all ages when an Ethnic is desirous of joining himself to Israel, 'and take upon him the

yoke of the law, he must be circumcised, and baptized, and bring a sacrifice; or, if it be a woman, be baptized and bring a sacrifice,' with several particulars respecting the nature of the offering that was to be brought, the time of performing the baptism, the number of witnesses necessary, &c. Maimonides further asserts that the judges received no proselytes in David's days, lest they should have come of fear; nor in Solomon's, lest they should have come because of the great prosperity of Israel. 'Notwithstanding there were many proselytes,' he adds, 'that in David's and Solomon's time joined themselves in the presence of private persons; and the judges of the great sanhedrim had a care of them. They drove them not away after they were baptized out of any place; neither took they them near to them until their after-fruits appeared.'

The Babylonian Talmud says the same thing with regard to receiving proselytes by baptism, according to Dr. Wall, and only differs with the Talmud Hiersosol. Jevamoth as to the number of witnesses that should be present; and here follow three quotations, which the doctor says are taken from the latter (published about A. D. 230), but which in point of fact are all from the former (compiled not earlier than A. D. 500), as Dr. Gill has long ago remarked. They are all from T. BAB Yebamot, fol. xlvi. 2, et Gloss. So that we have not, as yet, any authority earlier than the Babylonian Talmud, or a Collection of Jewish Traditions and Comments on the Law, published at the beginning of the sixth century of the Christian era. Leo Modena is then quoted to show that the modern Jews continue this practice.

The Gemara *Babylon*. tit. Cherithoth, and tit. Jabimoth (portions of this Talmud) are afterwards brought forward to prove that 'the books do speak of this washing or baptism as absolutely necessary; that 'he is no proselyte unless he be circumcised and baptized;' the Talmud Tract Repudii (also a part of the Babylonian Talmud), as quoted by Godwin in his *Moses and Aaron*, states that Jethro, the father-in-law of Moses, was 'made a proselyte by circumcision and immersion in waters;' the comment of Moses Kotsensis, a Jewish writer of the fourteenth century, that 'a purification by water' was necessary; and Drusius, a learned Fleming of the sixteenth century, that 'of a woman proselyte were required only purification by water and oblation.' It is on this collection of authorities (and we have mentioned them all) that Dr. Wall remarks, 'This custom of the Jews continued after Christ's time, and after their expulsion from the Holy Land; and continues, as I showed from Leo Modena, to this day.'

He now cites the testimony of Arrian, who (A. D. 147) calls the Jews *βεβαμμενος*, the dipped; and proceeds to show how the Jewish doctors 'prove the necessity of this washing and baptism from Moses' law; he says that many of them understand the command, Exod. xix. 10, for the people to sanctify themselves, as meaning to wash or baptize themselves; that Aben Ezra, who died A. D. 1174, understands Jacob's injunction to his family on the subject of meeting

God at Bethel, Genesis xxxv. 2, to refer to 'a washing of their whole bodies;' he mentions Selden as showing from several Jewish commentators that when the washing of garments is mentioned, Lev. xi. xiv., and in various other places, the washing of the whole body is intended; and again adverts to Maimonides and the Babylonian Talmud on the subject of the 'three things' required of a proselyte, because they were originally required of the Jews. Of these, says Maimonides, 'Baptism was in the wilderness, just before the giving of the law, as it is written, Sanctify them to-day and to-morrow and let them wash their clothes.' Dr. W. concludes his list of Jewish authorities with the words of R. Solomon, who lived in the twelfth century, 'Our rabbins teach that our fathers entered into covenant by circumcision and baptism, and sprinkling of blood.'

St. Gregory Nazianzen, Cyprian, Basil, and Tertullian, are then brought as early Christian witnesses of this baptism amongst the Jews. St. Gregory speaks of Moses giving a baptism or washing with water only, and that 'before that they were baptized with the cloud and the sea, as St. Paul reasons;' Cyprian of 'the baptism of the law and of Moses;' which Basil compares with that of John and Christ. 'Before them all, however,' observes Dr. Wall, 'Tertullian complains of the devil aping or imitating the things of God,' in the rites of Ceres and Apollo, which were accompanied with baptism; and which 'divine baptism,' so imitated, Dr. Wall says, must intend the Jewish baptism.

Such are the entire authorities of Dr. Wall for his first and most important position, that Jewish proselyte baptism was not only in existence before our Saviour's time, but even from the beginning of the Mosaic dispensation.

II. Dr. Wall secondly proposes to show, that the infants of proselytes born previous to their conversion to Judaism were baptized with their parents, and admitted as proselytes. The Babylonian Talmud is here again his first authority; then follows a passage from the text of the Mishna.

This is a compendium of Jewish traditions collected by R. Jehuda Hakkodesh, in the middle of the second century of the Christian era, and the most authentic depository of the oral law said to be delivered by Jehovah to Moses, together with the written law, during the forty days he was in Sinai. When Moses returned to his tent, according to Maimonides, he was attended by Aaron, to whom he recited the text (which alone was written) and taught the interpretation which he thus received; Eleazar and Ithamar then entered, to whom he repeated the sacred communications; then the seventy elders, to whom he again repeated the whole; afterwards entered the congregation at large, to whom it was once more repeated; and being thus heard by Aaron four times, by his sons three times, by the seventy elders twice, and by the congregation once, it became firmly and proportionally fixed in their memories. Rabbi Moses Kotsensis, quoted by Dr. Wall in a former page, says, 'If the oral law had not been added to the written law, the whole law would have been ob-

scure and unintelligible. For in the first place there are Scriptures contrary to each other; and, in the next place, the written law is imperfect, and comprehends not all that is necessary to be known.' 'He that has learned the Scripture and not the Mishna is a blockhead,' according to one of the maxims of the Gemara.

According to the Mishna, on which the Talmuds contain Glosses or Comments, a girl born of heathen parents and made a proselyte after she is three years and a day old, shall not have 'such and such privileges,' as Dr. Wall quotes it. That is, as the whole passage runs, a certain matrimonial dowry. The Babylonian Talmud says, that if she be made a proselyte before that age she shall have it; and the Gemara or Comment of this Talmud that 'they are wont to baptize such a proselyte in infancy upon the profession of the house of judgment; for this is for its good.' The Mishna itself, as quoted by Dr. Wall, has not a word respecting baptism or dipping, or how the proselyte was to be made such, nor the Jerusalem Talmud on the place. 'But they are wont to baptize,' says the above Gloss of the sixth century, 'because none is made a proselyte without circumcision or baptism.' It then speaks of the appointment of three men as a kind of sponsors for the education of the child.

Maimonides quotes this passage, therefore Dr. Wall quotes him again here; and from Selden the rule, originally found in the same Gemara or Gloss, that a male child was not to be considered capable of giving his own consent to become a proselyte until he was thirteen years old and a day; but a female might give her consent, or be proselyted in her own name, at twelve years and a day.

The opinions of several Jewish and Christian doctors are then quoted, as to the power of infants to retract their baptismal vows; and a quotation by Hammond of a 'saying' from Maimonides (who quotes it from the Babylonian Talmud), that 'A heathen woman, if she be made a proselyte when big with child, that child needs not baptism, for the baptism of the mother serves him for baptism.' Children born to proselytes after their parents were baptized, 'they reckoned were clean by their birth.'

And these are all the proofs of Jewish infant-baptism produced by Dr. Wall, beginning with a Jewish Commentary of the sixth century, and confirmed by subsequent writers.

III. Dr. Wall, thirdly, undertakes to prove that gentile infants found exposed, or taken in war, were frequently 'baptized for proselytes.' So says Maimonides; and by Dr. Wall the baptism of such a child is said to be according to the rule of rabbi Hezekiah, set down in the Jerusalem Talmud. This rule, however, which he recites, relates entirely to the dipping for servitude, or otherwise, or a civil designation totally distinct from the baptism of proselytes, as Maimonides himself states, the former being repeated (anabaptistically) in case of the servant ever becoming free; that is, he was then dipped or dipped himself, for the ten thousandth time perhaps, with a different object in view. See Isuri Biah, c. xiii. ss. 11 and 12, &c.

And these are Dr. Wall's authorities for his third conclusion.

IV. His fourth is entirely grounded on the preceding, viz. that the baptism of proselytes was called by the Jews a new birth, a regeneration, or being born again. He quotes the Babylonian Gemara and Maimonides in support of this, the latter of whom applies the same phrase to 'a servant made free.' Dr. Wall thinks that our Lord adopted this phraseology in his conversation with Nicodemus, that St. Paul alludes to it, 2 Cor. v. 16, 17, &c., and that the Fathers continued it in their manner of stating regeneration. This writer afterwards draws a sort of parallel between what he conceives to have been the Jewish and the early Christian modes of baptizing, with regard both to adults and infants; he again quotes the Babylonian Talmud, in reply to Sir Norton Knatchbull, to prove 'the wise men pronounced' that until he were 'both circumcised and baptized no gentile could be a proselyte;' this, however, is the statement of but one side of a dispute; and with rabbi Eliezer (who was on the other side) and who pronounced, even at this date, that a gentile circumcised and not baptized was an honorable proselyte, the decision is always held to rest. This is the entire amount of evidence produced by the doctor.

'A more singular instance of confused quotations,' says this writer, 'passing current with the world for proofs, never perhaps was afforded, than in the authority this Introduction has been allowed in the baptismal controversy. Wall never, it is clear, examined the works on which he ultimately rests this important part of his argument (and upon which so many respectable writers have rested their notions of the matter after him); he does not even seem to have paid the attention of an ordinary compiler to their dates. Thus a writer (Maimonides) of the latter end of the twelfth century, the Babylonian Talmud first published in the sixth century, and the Jerusalem Talmud (which he thinks he is quoting) of the third century, Moses Kotsensis who flourished in the fourteenth, and Drusius, a writer of the sixteenth century, are made to speak in succession as to the existence of a custom disputed in point of date, and evidently as if they were all speaking of the same period. After quoting the last writer he gravely says, 'this custom of the Jews continued after Christ's time, and after their expulsion from the Holy Land.'

**PROSEMINATION**, *n. s.* Lat. *prosemino*, *proseminatus*. Propagation by seed.

Touching the impossibility of the eternal succession of men, animals, or vegetables, by natural propagation or *prosemination*, the reasons thereof shall be delivered. *Hale*.

**PROSERPINACA**, in botany, a genus of the trigynia order, and triandria class of plants; natural order fifteenth, inunodate: *CAL.* tripartite superior: *cor.* none: there is one trilocular seed.

**PROSERPINE**, in fabulous history, the daughter of Jupiter and Ceres, and queen of hell. She was carried off by Pluto while gathering flowers. Ceres, after a tedious search, intrusted Jupiter to let her return from hell. To this request Jupiter consented, if she had tasted

nothing in hell; but Ascalaphus informing him that he had seen her eat part of a pomegranate, she was sentenced to continue in Tartarus as Pluto's spouse; but, to mitigate the grief of Ceres, Jupiter ordered her to spend six months on earth, and the other six months in the infernal regions. Some explain this fable to relate to the corn remaining six months in the earth.

**PROSEUCHÆ**, in antiquity [Gr. *προσευχη*, prayer], the places of prayer of the Jews, nearly the same as their synagogues. But the synagogues were originally in the cities, and were covered places; whereas, for the most part, the *proseuchæ* were out of the cities, and on the banks of rivers; having no covering, except perhaps the shade of some trees or covered galleries.

**PROSLAMBANOMENE**, a musical note in the Greek system. As the two tetrachords of the Greeks were conjunctive, or, in other words, as the highest note of the first served likewise for the lowest note of the second, it is plain that a complete octave could not be formed. To remedy this deficiency, therefore, one note beneath the lowest tetrachord was added, as an octave to the highest of the last tetrachord. Thus, if we suppose the first to have begun on B, the last must have ended upon A, to which one note subjoined immediately beneath the lowest B in the diatonic order must have formed an octave. But it appears from authors who have scrutinised antiquity with some diligence, and perhaps with as much success as the data upon which they proceeded could produce, that the names of the notes in the Greek system, which originally signified their natural station in the scale of ascending or descending sounds, were afterwards applied to their positions in the lyre. Higher or lower, then, according to this application, did not signify their degree of acuteness or gravity, but their higher or lower situation upon this instrument.

**PROSODY**, *n. s.* } Fr. *prosodie*; Gr. *προ-*  
**PROSODIAN**. } *σωδία*. That part of grammar which teaches the sound and quantity of syllables, and the measures of verse; one skilled in prosody.

Some have been so bad *prosodians*, as from thence to derive malum, because that fruit was the first occasion of evil. *Broune*.

Many of the rules and observations respecting *prosody* are taken from Sheridan's Art of Reading.

*Murray*.

**PROSODY**, in grammar, treats of the quantity of syllables, as well as their accent and sound; it has also been held to include the laws of versification. Its most important and popular application is to quantity, although its Greek etymon, *προσῳδία* (*προς*, *ᾠδή*) would certainly teach us to include accent, and therefore both pause and tune. We devote, however, a distinct article to **VERSIFICATION**, to which we refer the reader for much we should otherwise be here disposed to say on the latter topics; and under **QUANTITY** will be found what relates peculiarly to that subject. See **PRONUNCIATION**.

**PROSOPIS**, in botany, a genus of the monogynia order, and decandria class of plants: *CAL.* hemispherical and quadridentate: stigma simple; the legume inflated and monospermous.

PROSOPOPOEIA, *n. s.* Fr. *prosopopée*; (Gr. προσωποποιουα. Personification; a figure of rhetoric by which things are made persons.

These reasons are argued, and raised by the *prosopopoeia* of nature speaking to her children.

*Dryden.*

PROSPECT, *n. s.* } Lat. *prospectus*. View  
PROSPECTIVE, *adj.* } of something distant or future; view delineated; place of view; series of objects brought under the eye: the adjective corresponding.

To be king,  
Stands not within the *prospect* of belief,  
No more than to be Cawdor.

*Shakespeare. Macbeth.*

Man to himself  
Is a large *prospect*, raised above the level  
Of his low creeping thoughts. *Denham.*  
Eden and all the coast in *prospect* lay.

*Milton.*

The French king and king of Sweden are circum-  
spect, industrious and *prospective* too in this affair.

*Chad.*

Is he a prudent man, as to his temporal estate,  
that lays designs only for a day, without any *prospect*  
to, or provision for the remaining part of his life?

*Tillotson.*

It is better to marry than to burn, says St. Paul;  
a little burning felt pushes us more powerfully, than  
greater pleasures in *prospect* allure.

*Locke.*

Against himself his gratitude maintained,  
By favours past, not future *prospects* gained.

*Smith.*

There is a very noble *prospect* from this place: on  
the one side lies a vast extent of seas, that runs  
abroad further than the eye can reach: just opposite  
stands the green promontory of Surrentum, and on  
the other side the whole circuit of the bay of Naples.

*Addison.*

Present, sad *prospect*! can he ought descry,  
But what affects his melancholy eye;  
The beauties of the ancient fabrick lost  
In chains of craggy hills, or length of dreary coast?

*Prior.*

To say more of a man than one thinks, with a *pros-*  
pect of interest, is dishonest; and without it foolish.

*Pope.*

Claude Lorraine, on the contrary, was convinced,  
that taking nature as he found it seldom produced  
beauty: his pictures are a composition of the va-  
rious draughts which he has previously made from  
various beautiful scenes and *prospects*.

*Reynolds.*

*Prospects*, however lovely, may be seen  
Till half their beauties fade.

*Cowper.*

PROSPER, *v. a. & v. n.* } Fr. *prosperer*;  
PROSPERITY, *n. s.* } Lat. *prospero*. To  
PROSPEROUS, *adj.* } make happy; fa-  
PROSPEROUSLY, *adv.* } vor; to be happy  
PROSPEROUSNESS. } or successful:

*prosperity* and *prosperousness* mean success;  
*happiness*; good fortune: the adjective and ad-  
verb corresponding.

My word shall not return void, but accomplish  
that which I please, and it shall *prosper* in the thing  
whereunto I sent it.

*Isaiah.*

*Prosperity*, in regard of our corrupt inclination to  
use the blessings of Almighty God, doth prove  
a thing dangerous to the souls of men.

*Hooker.*

Kind gods, forgive  
Me that, and *prosper* him.

*Shakespeare. King Lear.*

*Prosperously* I have attempted, and  
With bloody passage led your wars, even to  
The gates of Rome. *Id. Coriolanus.*

All things do *prosper* best, when they are advanced  
to the better; a nursery of stocks ought to be in a  
more barren ground, than that whereunto you remove  
them. *Bacon.*

God's justice reaps that glory in our calamities,  
which we robbed him of in our *prosperity*.

*King Charles.*

Surer to *prosper*, than *prosperity*  
Could have assured us. *Milton.*

She visits how they *prospered*, bud, and bloom. *Id.*  
That neat kind of acer, whereof violins and mu-  
sical instruments are made, *prosper* well in these  
parts. *Brownie's Travels.*

All things concur to *prosper* our design;  
All things to *prosper* any love but mine. *Dryden.*

Those, who are *prosperously* unjust, are intitled to  
panegyrick, but afflicted virtue is stabbed with re-  
proaches. *Id.*

*Prosperity* which depends upon the caprice of  
others is of short duration. *Johnson.*

PROSSNITZ, or PROSTIEGOW, a trading town  
of the Austrian States in Moravia, the chief  
place of the district of Hanna, and situated in  
the midst of a very fertile tract. Nine miles  
S. S. W. of Olmutz.

PROSTATÆ GLANDULÆ, prostate glands.  
See ANATOMY.

PROSTERNATION, *n. s.* Lat. *prosterno*.  
Dejection; depression; state of being cast  
down; or act of casting down. A word not  
adopted.

Pain interrupts the cure of ulcers, whence are  
stirred up a fever, watching, and *prosternation* of  
spirits. *Wiseman.*

PROSTITUTE, *v. a., adj., & n. s.* } French  
PROSTITUTION, *n. s.* } *prostituér*;

Span. and Port. *prostituyr*; Lat. *prostituo*.  
To sell to wickedness; expose to crimes for a  
reward: bribed or sold to vice: a hireling or  
mercenary so sold. Commonly used of women  
sold to whoredom. Prostitution, the act or habit  
of being prostituted.

Do not *prostitute* thy daughter, to cause her to be  
a whore. *Leviticus xix. 29.*

Who shall prevail with them to do that themselves  
which they beg of God, to spare his people and his  
heritage, to *prostitute* them no more to their own  
sinister designs? *Decay of Piety.*

Marrying or *prostituting*,  
Rape or adultery. *Milton's Paradise Lost.*

It were unfit that so excellent and glorious a re-  
ward, as the gospel promises, should stoop down like  
fruit upon a full laden bough, to be plucked by every  
idle and wanton hand, that heaven should be *prosti-*  
tuted to slothful men. *Tillotson.*

At open fulsome bawdry they rejoice,  
Base *prostitute*! thus dost thou gain thy bread.

*Druden.*

An infamous woman, having passed her youth in  
a most shameless state of *prostitution*, now gains  
her livelihood by seducing others.

*Addison's Spectator.*

Affections, consecrated to children, husbands, and  
parents, are vilely *prostituted* and thrown away upon  
a hand at loo. *Addison.*

Their common loves, a lewd abandoned pack  
By sloth corrupted, by disorder fed,  
Made bold by want, and *prostitute* for bread.

*Prior*

No hireling she, no prostitute to praise. *Pope.*  
**PROSTRATE**, *adj. & v. a.* } *Lat. prostra-*  
**PROSTRATION**, *n. s.* } *tus.* Lying at  
 length; a posture denoting adoration and humili-  
 ation; hence lying at mercy: to lay flat; throw  
 down: the noun substantive corresponds, and  
 means, also, dejection; depression.

Once I saw with dread oppressed  
 Her whom I dread; so that with *prostrate* lying,  
 Her length the earth in love's chief cloathing dressed.  
*Sidney.*

A storm that all things doth *prostrate*,  
 Finding a tree alone all comfortless,  
 Beats on it strongly, it to ruinate. *Spenser.*

The warning sound was no sooner heard, than the  
 churches were filled, the pavement covered with  
 bodies *prostrate*, and washed with tears of devout  
 joy. *Hooker.*

Look gracious on thy *prostrate* thrall.  
*Shakspeare.*

In the streets many they slew, and fired divers  
 places, *prostrating* two parishes almost entirely.  
*Hayward.*

He heard the western lords would undermine  
 His city's wall, and lay his towers *prostrate*.  
*Fairfax.*

Our *prostrate* bosomes forc't with prayers to trie,  
 If any hospitable right, or boone  
 Of other nature, such as have bin wonne  
 By laws of other houses, thou wilt give. *Chapman.*

Your lordships must give me leave to say that the  
 poor Church of England humbly *prostrates* herself,  
 next after his sacred majesty, at your lordships' feet;  
 and humbly craves your compassion and aid.  
*Bp. Hall.*

Some have *prostrated* themselves an hundred times  
 in the day, and as often in the night. *Duppa.*  
 Grovelling and *prostrate* on yon lake of fire.  
*Milton.*

Nor is only a resolved *prostration* unto antiquity a  
 powerful enemy unto knowledge, but any confident  
 adherence unto authority. *Broune.*

Stake and bind up your weakest plants against the  
 winds, before they come too fiercely, and in a moment  
*prostrate* a whole year's labour. *Evelyn.*

The truths, they had subscribed to in speculation,  
 they reversed by a brutish senseless devotion, man-  
 aged with a greater *prostration* of reason than of  
 body. *South.*

The drops falling thicker, faster, and with greater  
 force, beating down the fruit from the trees, *prostrat-*  
*ing* and laying corn growing in the fields.  
*Woodward's Natural History.*

A sudden *prostration* of strength, or weakness, at-  
 tends this colick. *Arbuthnot.*

While *prostrate* here in humble grief I lie,  
 Kind virtuous drops just gathering in my eye.  
*Pope.*

The general idea of showing respect is by making  
 yourself less; but the manner, whether by bowing the  
 body, kneeling, *prostration*, pulling off the upper part  
 of our dress, or taking away the lower, is a matter of  
 custom. *Sir J. Reynolds.*

**PROSYLLOGISM**, *n. s.* Pro and syllogism.

A *prosyllogism* is when two or more syllogisms are  
 so connected together that the conclusion of the for-  
 mer is the major or the minor of the following.  
*Watts.*

**PROTAGORAS** a celebrated Greek philoso-  
 pher, born at Abdera. Being in his youth em-  
 ployed in carrying wood to Abdera, Democritus

met him one day, and, observing the logs packed  
 up with mathematical exactness, took him under  
 his protection, maintained him, and taught him  
 philosophy. He afterwards himself taught with  
 reputation at Athens, but was at length banished  
 thence for the alleged impiety of his doctrines.  
 Of this he was accused by different persons, and  
 among others by one of his scholars, viz. Eual-  
 thus, who asserted that in one of his books he  
 had said, 'concerning the gods I am wholly  
 unable to determine whether they have any  
 existence or not; for the weakness of the human  
 understanding, and the shortness of human life,  
 with other causes, prevent us from attaining this  
 knowledge.' Similar opinions were also to be  
 met with in some of his other writings, and, on  
 this account, they were ordered to be collected  
 and burnt in the market-place. He had unques-  
 tionably an inclination to scepticism. Adopting  
 the doctrine of Democritus, that the atoms of  
 which bodies are composed are in perpetual  
 motion, Protagoras conceived that external ob-  
 jects are liable to such continual fluctuation that  
 nothing can certainly be known of them; and  
 hence he concluded that nothing can be pro-  
 nounced to exist, but that which is at any instant  
 perceived by the senses; and that since these are  
 perpetually varying, things themselves accord-  
 ingly vary, so that, upon the same evidence, that  
 of the senses, contradictory opinions may be  
 advanced. On his banishment from Athens he  
 visited the islands in the Mediterranean, where  
 it is said that he was the first philosopher that  
 lectured for money. He died in a voyage to  
 Sicily, in a very advanced age. He commonly  
 reasoned by dilemmas, and left the mind in  
 suspense with respect to all the questions he  
 proposed. Plato wrote a dialogue against him.  
 He flourished about A. A. C. 400.

**PROTATICK**, *adj.* Fr. *protatique*; Gr.  
*πρωτατικός*. Previous.

There are *protatich* persons in the ancients, whom  
 they use in their plays to hear or give the relation.  
*Dryden.*

**PROTEA**, in botany, the silver tree, a genus  
 of the monogynia order, and tetrandria class of  
 plants; natural order forty-eighth, aggregatæ.  
 There is one quadrifid petal surrounding the  
 germ: CAL. none; the receptacle is paleaceous.  
 There are thirty-six species, all natives of the  
 Cape of Good Hope; of which the most re-  
 markable are:—

1. *P. argentea*, commonly called silver tree,  
 with a strong upright stem, covered with pur-  
 plish bark, dividing into several branches which  
 grow erect, garnished with broad, shining, silvery  
 leaves, which make a fine appearance when in-  
 termixed with other exotics. Through the whole  
 year it exhibits its glossy white or silvery leaves.  
 It has at first a very uncommon and beautiful  
 appearance, and sometimes in the course of twelve  
 or fifteen years reaches the height of twenty  
 feet, which it never exceeds. These trees are  
 generally planted near some farms, and very  
 seldom grow wild.

2. *P. confiera*, with linear, spear-shaped,  
 entire leaves, grows to the height of ten or  
 twelve feet, with a straight regular stem. The  
 branches naturally form a large regular head

The leaves are long and narrow, of a shining silver color; and, as they remain the whole year, make a fine appearance in the green-house.

3. *P. nitida*, or wageboom, greatly resembles the first sort: the leaves are very silky and white, with erect purple branches. All these plants, being tender exotics, require to be continually kept in the green-house during winter. The second may be propagated by cuttings, which should be cut off in April, just before the plants begin to shoot; the first and third sorts may be propagated by seeds.

**PROTECT**, *v. a.* } Fr. *protéger, protecteur*;  
**PROTECTION**, *n. s.* } Lat. *protectus*. To shelter;  
**PROTECTIVE**, *adj.* } ter; defend: afford im-  
**PROTECTOR**, *n. s.* } munity from evil; and in  
**PROTECTRESS**. } a modern sense (to avoid  
 'calling a spade a spade'), to keep as a concu-  
 bine: protection and protector follow these  
 senses: protective is defensive; sheltering: pro-  
 tectress, a woman who protects.

Drive toward Dover, friend, where thou shalt meet  
 Both welcome and protection.

*Shakspeare. King Lear.*

The king  
 Had virtuous uncles to protect his grace.

*Shakspeare.*

Is it concluded he shall be protector?  
 All things should be guided by her direction, as  
 the sovereign patroness and protectress of the enter-  
 prise.

*Bacon.*

Leave not the faithful side,  
 That gave thee being still shades thee and protects.

*Milton.*

Hither the' oppressed shall henceforth resort,  
 Justice to crave, and succour at your court;  
 And then your bigness, not for our's alone,  
 But for the world's protector shall be known.

*Waller.*

The law of the empire is my protection. Kettlewell.  
 Full in the midst of his own strength he stands,  
 Stretching his brawny arms and leafy hands,  
 His shade protects the plains.

*Dryden's Virgil.*

The obligations of hospitality and protection are  
 sacred; nothing can absolve us from the discharge  
 of those duties.

*L'Estrange.*

Behold those arts with a propitious eye,  
 That supplicant to their great protectress fly.

*Addison.*

The king of Spain, who is protector of the common-  
 wealth, received information from the great duke.

*Id.*

If the weak might find protection from the mighty,  
 they could not with justice lament their condition.

*Swift.*

The stately sailing swan guards his osier isle,  
 Protector of his young.

*Thomson.*

PROTECTOR is also a title given to the repre-  
 sentative of a Catholic nation, or religious order,  
 at the court of Rome, who is often a cardinal.

PROTECTORATE, the office of protector;  
 applied in British history to the office held by  
 Oliver Cromwell.

PROTEND, *v. a.* Lat. *protendo*. To hold  
 out; to stretch forth. Not used.

All stood with their protended spears prepared.

*Dryden.*

PROTESILAI TURRIS, the sepulchre of Pro-  
 tesilaus, with a temple, at which Alexander  
 sacrificed, situated at the south extremity of the  
 Hellespont, next to the Chersonesus Thracica.

PROTESILAUS, a king of part of Thessaly,  
 the son of Iphiclus, grandson of Phylacus, and  
 brother of Alcimede, the mother of Jason. He  
 was the first Greek who landed on the coast of  
 Troy, and the first slain by the Trojans. (Homer,  
 Ovid.) His wife Laodamia, to assuage her  
 grief, requested of the gods that his shade might  
 be permitted to visit her, and, obtaining her  
 request, she expired in his embraces. (Hyginus.)  
 Protesilaus was also called Phylacides, from  
 Phylace, a town of Thessaly, or rather from his  
 grandfather Phylacus.

**PROTEST**, *v. n., v. a., & n. s.* } Fr. *protes-*  
**PROTESTANT**, *n. s. & adj.* } ter; Span.  
**PROTESTANCY**, *n. s.* } and Port.  
**PROTESTATION**, } *protestar*;  
**PROTESTER**. } Ital. *protes-*

*tare*; Lat. *protestor*. To make a solemn decla-  
 ration of one's judgment or resolution; more  
 commonly used of an adverse judgment: to  
 prove; show; call as witness: a protest is a  
 solemn declaration of opinion; particularly the  
 solemn and expressed dissent of a peer of par-  
 liament from the opinion of the House of Lords:  
 protestant, one who in any way solemnly pro-  
 poses or objects his opinion; but particularly  
 one who adheres to the objections of the Reformed  
 against the Church of Rome: protestant, as an  
 adjective, relating to Protestants: protestancy,  
 the profession or religion of Protestants: pro-  
 testation is the dissent or resolution made or ex-  
 pressed: protester, he who makes or issues it.

He maketh protestation to them of Corinth, that  
 the gospel did not by other means prevail with them,  
 than with others the same gospel taught by the rest  
 of the apostles.

*Hooker.*

Here's the twin brother of thy letter; but let thine  
 inherit first, for, I protest, mine never shall.

*Shakspeare.*

The peaking cornuto comes in the instant, after  
 we had protested and spoke the prologue of our  
 comedy.

*Id.*

But to your protestation; let me hear  
 What you profess.

*Id. Winter's Tale.*

Did I use

To stale with ordinary oaths my love  
 To every new protester?

*Id. Julius Caesar.*

This is the first example of any protestant subjects  
 that have taken up arms against their king a protes-  
 tant.

*King Charles.*

What miserable subdivisions are there in our pro-  
 testancy!

*Bp. Hall.*

He protests against your votes, and swears  
 He'll not be tried by any but his peers.

*Denham.*

If the lords of the council issued out any order  
 against them, some nobleman published a protestation  
 against it.

*Clarendon.*

Fiercely they opposed

My journey strange with clamorous uproar,  
 Protesting fate supreme.

*Milton.*

The conscience has power to disapprove and to  
 protest against the exorbitances of the passions.

*South.*

Since the spreading of the protestant religion, several  
 nations are recovered out of their ignorance.

*Addison.*

I smiled at the solemn protestation of the poet in  
 the first page, that he believes neither in the fates or  
 destinies.

*Id.*

What if he were one of the latest protesters against  
 popery? and but one among many that set about  
 the same work!

*Atterbury.*



We receive but little advantage from repeated *protestations* of gratitude, but they cost them very much from whom we exact them in return.

*Goldsmith.*

Each peer has a right, by leave of the house, when a vote passes contrary to his sentiments, to enter his dissent on the journals of the house with the reasons for such dissent, which is usually styled his *protest*. 1 Comm. c. 2. Lord Clarendon relates that the first instances of *protests*, with reasons, in England, were in 1641; before which time they usually only set down their names as dissentient to the vote.

*Tomline.*

**PROTEST**, in commerce, is a writing executed by a notary public to secure to the holder of a bill recourse upon the indorsers when the drawer refuses to accept, or the acceptor fails to pay.

**PROTEST**, in parliament. Any of the lords in parliament have a right to protest their dissent from any bill passed by a majority; which protest is entered in form. This is said to be a very ancient privilege. The commons have no right to protest.

**PROTESTANTISM.** The emperor Charles V. called a diet at Spire, in 1529, to request aid from the German princes against the Turks, and to devise the most effectual means for allaying the religious disputes which then raged in consequence of Luther's opposition to the established religion. The emperor being at Barcelona, at the meeting of this diet, his brother Ferdinand, archduke of Austria, was appointed to preside. In this diet it was decreed, by Ferdinand and other popish princes, that, in the countries which had embraced the new religion, it should be lawful to continue in it till the meeting of a council; but that no Roman Catholic should be allowed to turn Lutheran; and that the reformers should deliver nothing in their sermons contrary to the received doctrine of the church. This decree was justly considered as iniquitous and intolerable by the elector of Saxony, the langrave of Hesse, and other members of the diet. Nor was any one of them so simple, or so little acquainted with the politics of Rome, as to look upon the promises of assembling speedily a general council in any other light than an artifice to quiet the minds of the people; since it was easy to perceive that a lawful council, free from the despotic influence of Rome, was the very last thing that a pope would grant in such a critical situation of affairs. Against this decree, therefore, six Lutheran princes (John and George, the electors of Saxony and Brandenburg; Ernest and Francis, the two dukes of Luncenburg; the langrave of Hesse; and the prince of Anhalt), with the deputies of thirteen imperial towns (Strasburg, Ulm, Nuremberg, Constance, Rottingen, Windsheim, Memmingen, Nortlingen, Lindau, Kempten, Heilbron, Wissemburg, and St. Gall), formally and solemnly *protested*, and declared that they appealed to a general council; and hence the name of **PROTESTANTS**, which, from this period, has been given to the followers of Luther. Nor was it confined to them; for it soon after included the Calvinists, and has now of a long time been applied indiscriminately to all the churches, sects, and denominations, in whatever country they may be found, which have separated from the see of Rome.

The important period which was distinguished by this reformation of religion, is not, as Protestants contend, to be considered as the period when the principles then embraced first made their appearance. Long, very long, had purity of doctrine and discipline slept beneath the overloaded ornaments and corruptions of the church of Rome; and there was a time when that church herself might have boasted of her primitive purity and freedom from error, with other churches of Christ: never, indeed, was there a time, from the date of her first departure from sound principles, wherein there were not witnesses to the truth; or some, more or less, who withstood the corruptions and depravity of their respective ages, maintained orthodox and primitive doctrine, and exhibited in their lives the genuine fruits of our most holy faith.

We are not to wonder that Protestantism soon exhibited a variety of religious opinion and practice. The active spirit of enquiry, natural to men who had just broken loose from the despotism of popery, operating differently on different intellects and dispositions, almost necessarily produced a variety of sects; and, in some cases, gave birth to extreme wildness and extravagance of unscriptural doctrine and practice. Protestants, therefore, have been far from unanimous in all points of doctrine, worship, church government, or discipline: on the contrary, while they agree only in receiving the Scriptures as the supreme rule of their faith and practice, and in rejecting the distinguishing doctrines of the church of Rome, particularly the authority ascribed by her members to tradition as a rule of faith, in many other respects they still differ not more widely from that church than they do from one another. And, to ascertain their doctrines, it will be necessary to examine their several *libri symbolici*, or the confessions and articles of the different churches, sects, and parties, into which professors of the reformed religion are now subdivided. The learned Chillingworth, addressing himself to a writer in favor of the church of Rome, speaks of the religion of Protestants in the following terms, worthy, as has been well observed, to be inscribed in letters of gold:— Know then, Sir, that when I say the religion of Protestants is, in prudence, to be preferred before yours; on the one side, I do not understand by your religion the doctrine of Bel-larmine, or Baronius, or any other private man amongst you, nor the doctrine of the Sorbonne, or of the Jesuits, or of the Dominicans, or of any other particular company among you, but that wherein you all agree, or profess to agree, 'The doctrine of the council of Trent.' so accordingly, on the other side, by the religion of Protestants I do not understand the doctrine of Luther, or Calvin, or Melancthon, nor the confession of Augsburg, or Geneva, nor the catechism of Heidelberg, nor the articles of the church of England—no, nor the harmony of Protestant confessions; but that wherein they all agree, and which they all subscribe with a greater harmony, as a perfect rule of faith and action, that is, the Bible. The Bible, I say, the Bible only, is the religion of Protestants. Whatsoever else they believe besides it, and the plain

infrangible, indubitable, consequences of it, well say they hold it as a matter of opinion; but, as a matter of faith and religion, neither can they, with coherence to their own grounds, believe it themselves, nor require belief of it of others, without most high and most schismatical presumption. I, for my part, after a long, and (as I verily believe and hope) impartial search of the true way to eternal happiness, do profess plainly, that I cannot find any rest for the sole of my foot, but upon this rock only. I see plainly, and with my own eyes, that there are popes against popes, and councils against councils; some fathers against other fathers, the same fathers against themselves; a consent of fathers of one age, against a consent of fathers of another age. Traditive interpretations of Scripture are pretended, but there are few or none to be found: no tradition, but that of Scripture, can derive itself from the fountain, but may be plainly proved either to have been brought in in such an age after Christ, or that in such an age it was not in. In a word, there is no sufficient certainty but of Scripture only, for any considering man to build upon. This, therefore, and this only, I have reason to believe. This I will profess: according to this I will live; and, for this, if there be occasion, I will not only willingly, but even gladly, lose my life; though I should be sorry that Christians should take it from me. Propose me any thing out of this book, and require whether I believe or no, and, seem it never so incomprehensible to human reason, I will subscribe it with hand and heart, as knowing no demonstration can be stronger than this, God hath said so, therefore it is true. In other things, I will take no man's liberty of judging from him; neither shall any man take mine from me.

But though the Bible is, properly speaking, their only *symbolic book*, or the only sure foundation upon which all true Protestants build every article of the faith which they profess, and every point of doctrine, which they teach, whereby they may be said to unite in subscribing to the sixth article of the United Church of England and Ireland; and though all other foundations, whether they be the decisions of councils, the confessions of churches, the rescripts of popes, or the expositions of private men, are considered by them as sandy and unsafe, or as in no wise to be ultimately relied on; yet, on the other hand, they do by no means fastidiously reject them as of no use. For while they admit the Bible, or the Scriptures of the Old and New Testaments, to be the only infallible rule by which we must measure the truth or falsehood of every religious opinion, they are sensible that all men are not equally fitted to apply this rule, considered in all its latitude; and that the wisest men want, on many occasions, all the helps of human learning, to enable them to understand its precise nature, and to define its certain extent. That is, the consistent Protestant must admit that all men are not equal judges of what nature, i. e. the national sense of propriety, taught the Corinthian ladies respecting the wearing of their hair, see 1 Cor. xi. 15, nor of the geographical question, whether the 'river of Egypt,' given as a boundary to Canaan in the

important grant, Gen. xv. 18, were or were not the river Nile: but it is an essential part of consistent Protestantism to maintain, with Chillingworth, not only the fulness, but the plainness, of Scripture, as a rule in all things needful to salvation. 'He that would usurp an absolute lordship over conscience,' says this admirable writer, 'need not put himself to the trouble and difficulty of abrogating and disannulling the laws made to maintain the common liberty; for he may frustrate them entirely, and compass his own design as well, if he can get the power and authority to interpret them as he pleases, and add to them what he pleases.' 'If you will stand to your rule, that Scripture is as perfect a rule of faith and practice as a writing can be, you must then grant it both so complete that it needs no addition, and so evident that it needs no interpretation; for both these properties are requisite to a perfect rule, and a writing is capable of both these properties.' The helps adverted to are great and numerous, having been supplied, in every age of the church, by the united labors of learned men in every country, and, we may add, particularly in Protestant communions.

With regard to church government, it may be here remarked in general, that, however widely Protestants may differ in other respects, they all agree in rejecting a universal, visible, supreme head of the church, together with the infallibility of any church governors or councils whatsoever, from the days of the apostles. They all likewise agree in adopting the principle of the independency of every church, either in its national or congregational character; as subject to no spiritual head but Christ; as conceding no superiority, and claiming no preeminence of jurisdiction; and as authorized to frame its own laws, and to regulate its own government: while, at the same time, a very great proportion of them equally concur in admitting the union of church and state, or the lawfulness of national establishments of religion. 'It is very remarkable,' says dean Comber, 'that a Romanist may turn Protestant without adding any one article to his faith; but a Protestant cannot turn to Rome unless he embrace many new articles: for our doctrines are generally confessed by both sides to be true; but those of the Roman church are rejected by our reformers as novel additions, and such as have no good foundations in Scripture nor genuine antiquity: and therefore the Protestant doctrines are the surer and safer, as in which both sides agree. For example, we and they both hold there are two states after this life, heaven and hell; but they add a third, which is purgatory; and this we deny: we and they both say that sins are to be remitted by the merits of Christ's death; but they add the merits of the saints, and their own satisfactions, with the merit of their own good works, which we deny to be expiatory, or such as can merit remission for us: we hold there be two sacraments, baptism and the eucharist: these they confess are the chief, but add five more, to which we affirm the name of sacraments doth not properly belong: we say that God alone is to be worshipped: they confess he is chiefly to be worshipped; but, then, they say the blessed Virgin Mary, angels, and saints

are to be worshipped also; which additions we deny: we say Christ is our only mediator and advocate: they confess he is principally so, but add that saints and angels are so in an inferior manner; which we utterly deny: we say Christ is really present in the sacrament of the altar: this they confess, but add he is corporally there, by the transubstantiation of the bread, &c.; and this we deny: we say there are twenty-two books of the Old Testament canonical, and they confess these all to be so, but they add divers others, and call them canonical, which we affirm to be apocryphal: we say the Scriptures are the rule of faith; and they will not absolutely deny it, but add their own traditions, which we reject. I could give more instances; but these may suffice to show that the Protestant doctrines look most like the ancientest, as being received by both parties; but the Roman opinions are novel enlargements added to the old Catholic truths.

PROTEUS, in mythology, a sea deity, the son of Oceanus and Tethys, or, as others say, of Neptune and Phœnice. From Neptune he received the gift of prophecy, and was often consulted on the coast of the Carpathian Sea by mortals. But on these occasions he was sometimes very shy, and shifted his votaries by assuming the shapes of various animals; and, while they held him fast as a sea god, eluded their grasp in the form of a fish or a serpent, unless they previously bound him with fetters. Hercules, Aristeus, and many other heroes, consulted him. Some say he reigned long in Egypt. He had two sons, Telegonus and Polygonus; and three daughters, Cabira, Fidothea, and Rhetia.

PROTEUS, in zoology, a genus of the class reptilia, order batraciens, of Cuvea, discovered in 1789 in the limestone caves of Carniola, and also in Mexico. The first protei described by Laurenti and Scopoli were not procured from the lake of Zirknitz, as has been commonly represented, nor from any of the caverns of Carniola, but were found accidentally by the peasants in small puddles of water near the mouths of certain caverns, a little distant from Sittich, on the road to Newstadt, in Lower Carniola, cast out of the caverns probably by the overflowing of their water after heavy rains. It was not till the year 1797 that these animals were discovered in the caverns of Maddalena. At present, the peasants of Adelsberg, when the season suits, go to fish for them, and preserve them alive, till they sell them to the curious, who visit Carniola, or convey them to Trieste, where they are sold for the small sum of two or three lire each.

Hermann and Schreibers wrote on the proteus, but described only its external parts, and contributed nothing to clear up the many doubts and conjectures respecting it. In this state of uncertainty, Dr. Schreibers first had recourse to anatomy, as the only satisfactory mode of gaining correct information: but unfortunately he possessed only three protei which had been sent to him from Carniola, preserved in spirits; which circumstance precluded him from giving that complete information which might otherwise have been expected from so eminent a naturalist. His description was published in 1801; and, among many excellent ob-

servations, he points out the striking difference of form between the lungs of the sirena lacertina and those of the proteus. Next to Schreibers we have to notice two zoologists of the highest celebrity, MM. Cuvier and Rudolphi, both of whom examined the internal structure of this animal. The former first discovered, and accurately described, the organs of generation in the female, and established, on a solid foundation, that the proteus was not a larva, as many had supposed, but a perfect animal; an opinion now generally followed, and confirmed by the recent observations of Rudolphi, who has described the generative system in the male.

The sirena lacertina occupies the same class and order, and is another genus consisting only of one species. It is said, like the proteus, to retain through its whole life three gills on each side the neck, and to possess, at the same time, lungs internally. A most ample description of this curious reptile was furnished to the Edinburgh Philosophical Journal, by professor Configliachi, and Dr. Rusconi, to the fourth volume of which we must refer the reader for more ample information.

PROTHONOTARY, *n. s.* Fr. *protonotaire* - Lat. *protonotarius*. The head register.

Saligniaeus, the pope's *prothonotary*, denies the Nabians professing of obedience to the bishop of Rome. *Brewood.*

He had the *prothonotariship* of the chancery. *Carew.*

PROTHONOTARY [from *πρωτος* Gr. first, and *notarius*, Lat.] properly signifies first notary, and was anciently the title of the principle notaries of the emperors of Constantinople.

PROTHONOTARY is used in England for an officer in the court of king's bench and common pleas; the former of which courts has one, and the latter three. The prothonotary of the king's bench records all civil actions sued in that court, as the clerk of the crown-office does all criminal causes. The prothonotaries of the common pleas enter and enrol all declarations, pleadings, assizes, judgments, and actions; they also make out all judicial writs, except writs of habeas corpus and *distringas jurator*, for which there is a particular office, called the habeas corpus office; they likewise enter recognizances acknowledged, and all common recoveries; make exemplifications of records, &c.

PROTHONOTARY, in the courts of Rome. There is a college of twelve prelates, called apostolical prothonotaries, empowered to receive the last wills of cardinals, to make all informations and proceedings necessary for the canonisation of saints, and all such acts as are of great consequence to the papacy; for which purpose they have the right of admission into all consistories. They also attend on the pope, whenever he performs any extraordinary ceremony out of Rome.

PROTOCOL, *n. s.* Belg. *protokol*; Fr. *protocole*; Gr. *πρωτοκολλον*, from *πρωτος* and *κολλη*. The original copy of a writing; or the rough memorandum of a diplomatic conference.

An original is stiled the *protocol*, or scriptura matrix; and if the *protocol*, which is the root and foundation of the instrument, does not appear, the instrument is not valid. *Ayliffe.*

**PROTOGENES**, a celebrated ancient painter, born at Carnas, a city of Caria, subject to the Rhodians, who flourished about A. A. C. 300. He was at first employed in painting ships, &c., but soon acquired the highest fame for historical pieces. His most celebrated piece was Jalyesus, the founder of Jalyesus, a city of Rhodes. Apelles gave him fifty talents (about £10,000) for one picture, which the Rhodians purchased back from him at a still higher price. He lived very abstemiously.

**PROTOPLAST**, *n. s.* Gr. *πρωτος* and *πλασος*. Original; thing first formed as a copy.

The consumption was the primitive disease, which put a period to our *protoplasts*, Adam and Eve.

Harvey.

**PROTOTYPE**, *n. s.* Fr. *prototype*; Greek *πρωτοτυπος*. The original of a copy; archetype; exemplar.

Man is the *prototype* of all exact symmetry.

Wotton.

The image and *prototype* were two distinct things; and therefore what belonged to the exemplar could not be attributed to the image.

Stillingfleet.

**PROTRACT**, *v. a. & n. s.* Lat. *protractus*.

**PROTRACTOR**, *n. s.*

**PROTRACTION**,

**PROTRACTIVE**, *adj.*

The derivations all corresponding.

Since I did leave the presence of my love,  
Many long weary days I have out-worn,

And many nights, that slowly seemed to move  
Their sad *protract* from evening until morn. Spenser.

Where can they get victuals to support such a  
multitude, if we do but *protract* the war? Knolles.

Our works are nought else

But the *protractive* trials of great Jove,  
To find perasive constancy in men. Shakespeare.

Those delays

And long *protraction*, which he must endure,  
Betray the opportunity. Daniel.

As to the fabulous *protractions* of the age of the world by the Egyptians, they are uncertain idle traditions.

Hale.

He suffered their *protractive* arts,

And strove by mildness to reduce their hearts.

Dryden.

**PROTRACTOR**, an instrument for laying down and measuring angles upon paper with accuracy and despatch; and by which the use of the line of chords is superseded.

The **CIRCULAR PROTRACTOR** is a complete circle, and is superior by far to either the right-angled or semi-circular, both in point of accuracy and despatch, especially when several angles are to be formed at the same point. The limb of this instrument is divided into 36°, and each degree in some protractors is halved; it has a subdividing scale or vernier, by which an angle may be laid down or measured to a single minute. In the centre of the protractor is a mark, which, when an angle is to be protracted or measured, is to be laid upon the angular point, and O, or zero on the limb, upon the given line forming one side of the angle.

The **RECTANGULAR PROTRACTOR** is constructed in form of a right-angled parallelogram, which, when applied to a case of mathematical instruments, is substituted in place of the semi-circular protractor and scale of equal parts.

**PROTREPICAL**, *adj.* Gr. *προτρεπτικος*. Hortatory; suasory.

The means used are partly didactical and *protrepical*; demonstrating the truths of the gospel, and then urging the professors to be steadfast in the faith, and beware of infidelity.

Ward on Infidelity.

**PROTRUDE**, *v. a. & v. n.* Lat. *protrudo*.  
**PROTRUSION**, *n. s.* } To thrust forward; thrust itself forward: the act of thrusting forward.

If the spirits be not merely detained, but *protrude* a little, and that motion be confused, there followeth putrefaction.

Bacon.

When the stomach has performed its office upon the food, it *protrudes* it into the guts, by whose peristaltick motion it is gently conveyed along. Locke.

One can have the idea of one body moved, whilst others are at rest; then the place it deserted gives us the idea of purer space without solidity, whereto another body may enter without either resistance or *protrusion* of any thing.

Id.

They were not left, upon the sea's being *protruded* forwards, and constrained to fall off from certain coasts by the mud or earth, which is discharged into it by rivers.

Woodward.

His left arm extended, and fore finger *protruded*.

Garlick.

**PROTUBERANCE**, *n. s.* } Lat. *protuberans*.  
**PROTUBERANT**, *adj.* } Something swelling out; prominence; tumor; the adjective corresponding.

If the world were eternal, by the continual fall and wearing of waters, all the *protuberances* of the earth would infinite ages since have been levelled, and the superficies of the earth rendered plain.

Hale.

Mountains seem but so many wens and unnatural *protuberances* upon the face of the earth.

More.

One man's eyes are more *protuberant* and swelling out, another's more sunk and depressed.

Glanville.

If the navel *protuberates*, make a small puncture with a lancet through the skin, and the waters will be voided without any danger of a hernia succeeding.

Sharp's Surgery.

**PROUD**, *adj.* } Sax. *þruðe*, *þruce*; Goth. *PROUDLY*, *adv.* } and Swed. *prud*. See **PRIDE**. Arrogant; self-exalted; haughty; elated, taking of before the object of pride; daring; presumptuous; ostentatious; salacious; exuberant; swelling (as 'proud flesh'); lofty of mien or manner; grand; splendid: the adverb follows these senses.

By his understanding he smiteth through the *proud*.

Job.

The patient in spirit is better than the *proud* in spirit.

Eccles.

The blood foretold the giant's fall,

By this *proud* palmer's hand. Drayton.

I better brook the loss of brittle life,  
Than those *proud* titles thou hast won of me.

Shakespeare.

He bears himself more *proudly*  
Even to my person, than I thought he would. Id.

So much is true, that the said country of Atlantis, as well as that of Peru, then called Coya, as that of Mexico, then named Tyrabel, were mighty and *proud* kingdoms in arms, shipping, and riches.

Bacon's New Atlantis.

A man is certainly *proud* of that knowledge he despises others for the want of.

Mason

The *proud* attempt thou hast repelled.

Milton.

He like a *proud* steed reined, went haughty on. *Id.*

The swan

Between her white wings mantling *proudly* rows.

*Id.*

Scaliger gave it (camphor) unto a bitch that was *proud*.

Browne's *Vulgar Errors*.

Fortune, that, with malicious joy,

Does man her slave oppress,

*Proud* of her office to destroy,

Is seldom pleased to bless. *Dryden's Horace*.

Storms of stones from the *proud* temple's height

Pour down, and on our battered helmets alight.

*Dryden*.

Ancus follows with a fawning air ;

But vain within, and *proudly* popular. *Id.*

If thou beest *proud*, be most instant in praying for humility.

*Duty of Man*.

*Proudly* he marches on, and void of fear ;

Vain insolence.

*Addison*.

When the vessels are too lax, and do not sufficiently resist the influx of the liquid, that begets a fungus or *proud* flesh.

*Arbuthnot*.

*Proud* Sparta with their wheels resounds.

*Pope*.

The *proudest* admirer of his own parts might find it useful to consult with others, though of inferior capacity.

*Watts*.

If it were a virtue in a woman to be *proud* and vain in herself, we could hardly take better means to raise this passion in her, than those that are now used in their education.

*Law*.

What is all righteousness that men devise !

What—but a sordid bargain for the skies ?

But Christ as soon would abdicate his own,

As stoop from heaven to sell the *proud* a throne.

*Cowper*.

PROVE, *v. a. & v. n.* } Fr. *proover* ; Ital.

PROVEABLE, *adj.* } *protare* ; Spanish *probar* ; Lat. *probo*. To evince ; to show or attest

by argument or testimony ; to try ; experience ; endure : as a verb neuter to make true ; be found experimentally ; succeed : proveable is, demonstrable ; that may be proved.

For the dai of the Lord schal *declare*, for it schal be schewid in fier, the fier schal *prue* the werk of ech man, what maner of werk it is.

*Wiclif. 1 Cor. 3.*

Who so delyteth to *prouen* and assay,

Of waveryng fortune the vncertayne lot,

If that the aunswere please you not alway,

Blame ye not me. *Sir T. More*.

Wilt thou thy idle rage by reason *prove* ?

Or speak those thoughts which have no power to move ?

*Sandys*.

Let the trumpet sound :

If none appear to *prove* upon thy person

Thy heinous, manifest, and many treasons,

There is my pledge : I'll *prove* it on thy heart.

*Shakspeare*.

Delay not the present, but

Filling the air with swords advanced, and darts,

We *prove* this very hour. *Id. Coriolanus*.

Children *prove*, whether they can rub upon the breast with one hand, and pat upon the forehead with another.

*Bacon*.

If the experiment *proved* not, it might be pretended that the beasts were not killed in the due time.

*Id.*

Could sense make Marius sit unbound, and *prove* The cruel lancing of the knotty gout ?

*Davies*.

In a set copy every fault is important, and may *prove* a rule of error.

*Bp. Hall*.

So both their deeds compar'd this day shall *prove*

Milton.

Thy overpraising leaves in doubt

The virtue of that fruit, in thee first *proved*. *Id.*

Smile on me, and I will *prove*

Wonder is shorter lived than love. *Waller*.

Well I deserved Evadne's scorn to *prove*,

That to ambition sacrificed my love. *Id.*

Let him in arms the power of Turnus *prove*,

And learn to fear whom he disclaims to love.

*Dryden*.

The sons prepare,

Meeting like winds broke loose upon the main,

To *prove* by arms whose fate it was to reign. *Id.*

If it *prove* any thing, it can only *prove* against our author, that the assignment of dominion to the eldest is not by divine institution.

*Locke*.

In spite of Luther's declaration, he will *prove* the tenet upon him.

*Aterbury*.

When the inflammation ends in a gangrene, the case *proves* mortal.

*Arbuthnot*.

Property, you see it alter,

Or in a mortgage *prove* a lawyer's share,

Or in a jointure vanish from the heir. *Pope*.

PROVED'ITOR, or } Ital. *proveditore*. One

PROVEDORE', *n. s.* } who undertakes to procure

military supplies.

The Jews, in those ages, had the office of *provedore*.

*Friend*.

PROVENDER, *n. s.* Fr. *provende* ; Ital. *provenda* ; Belg. *provande*. Dry food for brutes ; hay and corn.

Good *provender* labouring horses would have.

*Tusser*.

I do appoint him store of *provender* ;

It is a creature that I teach to fight. *Shakspeare*.

For a fortnight before you kill them, feed them with hay or other *provender*.

*Mortimer*.

Whene'er he chanced his hands to lay

On magazines of corn or hay,

Gold ready coined appeared, instead

Of paltry *provender* and bread.

*Swift's Miscellanies*.

PROVENCE, a ci-devant province of France, bounded by Dauphine on the north, by the late Piedmontese on the east, by the Mediterranean on the south, and by the Rhone, which separated it from Languedoc, on the west, being 138 miles long and 100 broad. The air is cold near the Alps, hot on the coast, and temperate in the middle. Since the revolution it has been divided into the following departments :—

	Sq. Miles.	Population.
The Lower Alps . . . . .	2845	146,000
The Var . . . . .	2820	284,000
The Mouths of the Rhone	2272	320,000
Total . . . . .	7937	750,000

To these is to be added a portion of the department of the Vaucluse. The principal towns are Marseilles, Toulon, Aix, Arles, and Grasse. It was divided into the Upper and Lower Provence.

PROVERB, *n. s. & v. a.* } Fr. *proverbe* ;

PROVER'BIAL, *adj.* } Ital. *proverbio* ;

PROVER'BIALLY, *adv.* } Lat. *proverbium*.

A pithy saying ; a saw ; an adage : the verb, to mention in, or provide with, a proverb, has been very properly disused : the adjective and adverb correspond with the noun substantive.

Thou hast delivered us for a spoil, and a *proverb* of reproach.

*Tob. iii. 4.*

Let wantons, light of heart,  
Tickle the senseless rushes with their heels ;  
For I am proverb'd with a grandsire phrase ;  
I'll be a candle-holder and look on. *Shakespeare.*  
It is in praise and commendation of men, as it is  
a gettings and gains ; for the proverb is true, that  
great gains make heavy purses ; for light gains come  
quick, whereas great come but now and then.

*Bacon's Essays.*

The sum of his whole book of *proverbs* is an exhortation  
to the study of this practick wisdom.

*Decay of Piety.*

The *proverbs* of several nations were much studied  
in Bishop Andrews, and the reason he gave, was,  
because by them he knew the minds of several na-  
tions, which is a brave thing. *Selden.*

Am I not sung and *proverbed* for a fool

In every street ; do they not say, how well

Are come upon him his deserts ? *Milton.*

He (Solomon), did wonderfully excel in ethics ;  
concerning which he spake three thousand *proverbs*,  
or moral aphorisms. *Barrow.*

It is *proverbially* said, *formicæ sua bilis inest, ha-  
bet et musca splenem* ; whereas these parts anatomy  
with not discovered in insects. *Browne.*

In case of excesses, I take the German *proverbial*  
cure, by a hair of the same beast, to be the worst in  
the world ; and the best, the monks diet, to eat till  
you are sick, and fast till you are well again.

*Temple's Miscellanies.*

The *proverb* says of the Genoese, that they have a  
sea without fish, land without trees, and men with-  
out faith. *Addison.*

Moral sentences and *proverbial* speeches are nu-  
merous in this poet. *Pope.*

People will, in a great degree, and not without  
reason, form their opinion of you, upon that which  
they have of your friends ; and there is a Spanish  
*proverb* which says, very justly, ' Tell me with whom  
you live, and I will tell you who you are.'

*Chesterfield.*

PROVERBS, BOOK OF, a canonical book of the  
Old Testament, containing a part of the proverbs  
of Solomon. The first twenty-four chapters are  
the work of that prince ; the next five are a col-  
lection made by order of king Hezekiah ; and  
the authors of the two last are Agur, the son of  
Jahel, and king Lemuel.

PROVIDE, v. a.

PROVIDENCE, n. s.

PROVIDENT, adj.

PROVIDENTIAL,

PROVIDENTIALLY, adv.

PROVIDENTLY,

PROVIDER, n. s.

Lat. *provideo*. To  
procure, or supply,  
beforehand ; fur-  
nish ; get ready, tak-  
ing of or with before  
the object : ' to pro-  
vide against ' is to

take measures to counteract or escape ; ' provide  
for,' to take care of ; maintain : ' provided that'  
means, conditioned that : providence is, forecast ;  
forethought ; timely care ; prudence ; frugality ;  
act of providing ; in a theological sense, God's  
care of all his creatures : providential and providen-  
tially are generally used in this last sense :  
provide is, prudent ; forecasting : providently  
corresponding : provider, he who provides.

God will *provide* himself a lamb for a burnt offer-  
ing. *Genesis.*

The only people which, as by their justice and *pro-  
vidence*, give neither cause nor hope to their neigh-  
bours to annoy them, so are they not stirred with  
false praise to trouble others' quiet. *Sidney.*

Eternal *providence* exceeding thought,

Where none appears can make himself a way.

*Spenser.*

States, which will continue, are above all things  
to uphold their reverend regard of religion, and to  
*provide* for the same by all means. *Hooker.*

This appointeth unto them their kinds of working,  
the disposition whereof, in the purity of God's own  
knowledge, is rightly termed *providence*. *Id.*

He hath intent, his wonted followers

Shall all be very well *provided* for. *Shakespeare.*

I take your offer, and will live with you ;

*Provided* that you do no outrages. *Id.*

I saw your brother,

Most *provident* in peril, bind himself

To a strong mast that lived upon the sea. *Id.*

Here's money for my meat,

I would have left it on the board, so soon

As I had made my meal, and parted thence

With prayers for the *provider*. *Id.*

A *provident* man *provides* for the future. *Raleigh.*

*Providence* is an intellectual knowledge, both fore-  
seeing, caring for, and ordering all things, and doth  
not only behold all past, all present, and all to come ;  
but is the cause of their so being, which prescience is  
not. *Id.*

To make experiments of gold, he *provided* of a con-  
servatory of snow, a good large vault under ground,  
and a deep well. *Bacon.*

*Providence* for war is the best prevention of it.

*Id.*

The king forthwith *provides* him of a guard,

A thousand archers daily to attend. *Daniel.*

He happier seat *provides* for us. *Milton.*

The world was all before them, where to chuse

Their place of rest, and *providence* their guide. *Id.*

First crept

The parsimonious emmet, *provident*

Of future. *Id.*

Sagacity of brutes in defending themselves, *provid-  
ing* against the inclemency of the weather, and care  
for their young. *Hale.*

Though the *providence* of God doth suffer many  
particular churches to cease, yet the promise of the  
same God will never permit that all of them at once  
shall perish. *Pearson.*

Orange with youth, experience has,

In action young, in council old ;

Orange is what Augustus was,

Brave, wary, *provident*, and bold. *Waller.*

They could not move me from my settled faith in  
God and his *providence*. *More's Divine Dialogues.*

Nature having designed water fowls to fly in the  
air, and live in the water, she *providently* makes  
their feathers of such a texture that they do not ad-  
mit the water. *Boyle.*

He went,

With large expence and with a pompous train

*Provided*. *Dryden.*

Some men, instructed by the labouring ant,

*Provide* against the' extremities of want. *Id.*

By thrift my sinking fortune to repair,

Though late, yet is at last become my care ;

My heart shall be my own, my vast expence

Reduced to bounds, by timely *providence*. *Id.*

*Provided* that he set up his resolution not to let  
himself down below the dignity of a wise man.

*L'Estrange.*

Every animal is *providentially* directed to the use  
of its proper weapons. *Ray on the Creation.*

An earth well *provided* of all requisite things for  
an habitable world. *Burnet's Theory.*

The lilies grow and the ravens are fed according  
to the course of nature, and yet they are made argu-  
ments of providence, nor are these things less *provi-  
dential*, because regular. *Burnet.*

My arbitrary bounties undenied ;

I give reversions, and for heirs *provide*. *Garth*

He will have many dependents, whose wants he cannot provide for.

*Addison.*

It happened, very providentially to the honour of the Christian religion, that it did not take its rise in the dark illiterate ages of the world, but at a time when arts and sciences were at their height.

*Id.*

This thin, this soft contexture of the air, Shows the wise author's providential care.

*Blackmore.*

An established character spreads the influence of such as move in a high sphere, on all around; it reaches farther than their own care and providence can do.

*Atterbury.*

A very prosperous people, flushed with great successes, are seldom so pious, so humble, so just, or so provident, as to perpetuate their happiness.

*Id.*

Rome, by the care of the magistrates, was well provided with corn.

*Arbuthnot on Coins.*

Fraudulent practices were provided against by laws.

*Arbuthnot.*

When the monasteries were granted away, the parishes were left destitute, or very meanly provided of any maintenance for a pastor.

*Swift's Miscellanies.*

They were of good birth, and such who, although inheriting good estates, yet happened to be well educated, and provided with learning.

*Swift.*

PROVIDENCE. That there exists a divine providence, or, in other words, that the Deity attends to the affairs of this world, and directs their course, has been an opinion generally received among mankind, in all ages, and in all countries of the world. It has not, however, passed without opposition from philosophers in various ages, as well as the present. The most ancient of these were Democritus, Leucippus, and Epicurus. We think it totally unnecessary, however, to state the arguments on either side, as they would lead into a discussion of the much disputed doctrines about the origin of evil, liberty, and necessity, free-will, predestination, &c., which have been sufficiently noticed elsewhere. The weight of the argument indeed lies on the side of the affirmative, both for a general and particular Providence. Every argument that has been advanced in favor of the eternal self-existence, infinite power, wisdom, and goodness of God, is equally decisive in favor of his superintending care over all his works. See THEOLOGY.

PROVIDENCE, an island near the coast of Honduras, eleven miles long and four wide, and celebrated in the history of the buccaneers, who fortified it for some years. Its western extremity, called the island of Santa Catalina, is separated from the rest of the island by a narrow channel, over which was thrown a bridge. It has been considered one of the best of the West India islands for fertility, and the salubrity of its climate; to which may be added the facility of its fortification and defence, and the abundance of its fine water.

PROVIDENCE, a post-town, port of entry, and semi-metropolis of Rhode Island, in a county of the same name; fifteen miles N. N. W. of Bristol, thirty north by west of Newport, forty S. S. W. of Boston, and fifty-nine north-east of New London, is situated on both sides of Providence River, just above the mouth of the Seekhonk, or Pawtucket, and thirty-five miles from the ocean. It is a pleasant, well-built, and very thriving

town, well situated for trade, and has a flourishing commerce, and extensive manufactures. The shipping owned here in 1810, amounted to 14,465 tons. The river is navigable as far as the town for vessels of 900 tons. The two parts of the town are connected by an elegant bridge, ninety feet in breadth. In point of population, it is the first town in Rhode Island, and the third in New-England. It contains a court-house, a jail, a university, a public library of about 2000 volumes, a Friends' boarding-school and five public schools, seven banks, including a branch of the United States bank, and eight houses of public worship: three for Congregationalists, two for Baptists, one for Episcopalians, one for Friends, and one for Methodists. Two of the Congregational, and one of the Baptist meeting-houses, and the Episcopal church, are among the handsomest edifices of the kind in the United States. Many of the private houses are elegant, and some of them very finely situated. Among the manufacturing establishments are four cotton manufactories, a large woollen manufactory, a paper-mill, a bleaching, dyeing, and calendering company. These manufactories are aided by three steam engines. Three newspapers are published here, one twice a-week, and two once a-week. A little to the east of the town there are two handsome bridges across the Seekhonk.

This town was originally settled, in 1636, by Roger Williams, to whom is ascribed the honor of having established the first political community in which perfect religious toleration was admitted. Brown University was originally founded at Warren in 1764, and removed to Providence in 1770. It received its present name in 1804 from Nicholas Brown, esq., one of its principal benefactors. It is a respectable and flourishing seminary. Its funds are not large, having arisen solely from individual liberality. The college building is a spacious and elegant brick edifice, four stories high, 150 feet long, forty-six broad, with a projection of twenty-feet on each side; and it contains forty-eight rooms for students, and six rooms for public purposes. It is delightfully situated on an eminence on the east side of the town, commanding a fine prospect. The library contains about 3000 volumes, and the philosophical apparatus is respectable.

The board of trustees is composed of thirty-six members; of whom twenty-two must be Baptists, five Friends, five Episcopalians, and four Congregationalists. The number of fellows, or learned faculty, is twelve; of these eight, including the president must be Baptists; the other four may be of any denomination; as also may be the professors and tutors. The executive government consists of the president, seven professors, and two tutors.

PROVIDENCE, NEW, an island of the West Indies, nearly in the centre of the great Bahama Bank, is twenty-five miles long and nine broad. The harbour of Nassau is on the north side, and is sheltered to the north by Hog Island; it is fit for vessels of thirteen feet. The town of Nassau is the seat of government of the Bahamas, and one of the best planned towns of the West Indies; the streets being wide and airy, and the houses well built. The trade here, particularly

with the United States, was at a late period very considerable. Its chief objects were live stock, and salt and fresh provisions; which latter have been chiefly obtained from the more southern of the states. A considerable intercourse has likewise occasionally taken place between New Providence and the Island of Cuba; particularly to the Havannah, where there was a brisk market for British manufactures, prize goods, &c., through the facilities rendered by the licence trade. In May, 1803, there had been granted in this island, by the crown, no less than 23,079 acres of patented estates, for the purpose of cultivation. The population, in 1801, amounted to 1599 whites, 752 free people of color, and 3361 slaves, making a total of 6212; and in 1803 to 1758 whites, 817 people of color, and 2515 slaves, the total being 5090.

At Nassau, there are two parish churches, and an old fort near the west entrance of the harbour. The government house (built in 1804) is one of the best in the West Indies, and is finely situated on a hill that commands the town and harbour. Here also is Fort Fincastle, and a small light-house. The public buildings, courts of justice, &c., are handsome and commodious. The barracks situated in Fort Charlotte, a little to the west of Nassau, were erected at a great expense by the earl of Dunmore, a late governor of the Bahamas. There is a very good road, extending for a considerable way along the coast of New Providence, and likewise one across the island from Nassau to the south. The island is situated between long. 77° 10' and 77° 38' W., lat. 25° 3' N.

PROVIDENCE, NORTH, a town of Providence county, Rhode Island, on the west side of the Pawtucket. It lies on the north side of Providence, and contains several cotton manufactories, two banks, and an air furnace. Pawtucket village is in this township.

Also a town of Saratoga county, New York.

PROVIDENCE RIVER, a river of Rhode Island, formed by the Wanasquatucket and Moshasick, which unite just above Providence. It flows into Narraganset Bay, at Bullock's Point, five or six miles below Providence.

PROVINCE, *n. s.* } Fr. *province* ;  
 PROVINCIAL, *adj. & n. s.* } Ital., Span., Port.,  
 PROVINCIATE, *v. a.* } and Lat. *provincia*.  
 A conquered region or tract of country; a country governed by delegated authority; hence any one's proper sphere or business: provincial is, relating or belonging to a province; unpolished; rude; not oecumenical: and, as a noun substantive, a spiritual delegate among the Jesuits and other religious orders: to provinciate; to make into a province. Not used.

Those provinces these arms of mine did conquer. *Shakespeare.*

The duke dare not more stretch  
 This finger of mine, than he dare rack his own;  
 His subject am I not, nor here provincial. *Id.*

When there was a design to provinciate the whole  
 kingdom, Druina, though offered a canton, would not  
 accept of it. *Houel.*

Over many a tract  
 Of heaven they marched, and many a province wide. *Milton.*

Some have delivered the polity of spirits, and left a;  
 account even to their provincial dominions. *Browne.*

I am fit for honours' toughest task;  
 Nor ever yet found fooling was my province. *Otway.*

Nor can I alone sustain this day's province. *Mora.*

Valignanus was provincial of the Jesuits in the  
 Indies. *Stillingfleet.*

Greece, Italy, and Sicily, were divided into com-  
 monwealths, till swallowed up and made provinces  
 by Rome. *Temple.*

'Tis thine, whate'er is pleasant, good, or fair;  
 All nature is thy province, life thy care. *Dryden.*

They build and treat with such magnificence,  
 That, like the ambitious monarchs of the age,  
 They give the law to our provincial stage. *Id.*

The woman's province is to be careful in her oeco-  
 nomy, and chaste in her affection. *Tatler.*

He has caused fortified towns and large provinces  
 to be restored, which had been conquered long be-  
 fore. *Davenant.*

A law made in a provincial synod is properly  
 termed a provincial constitution. *Auliffe's Parergon.*

See them broke with toils, or sunk in ease,  
 Or infamous for plundered provinces. *Pope.*

A country squire having only the provincial accent  
 upon his tongue, which is neither a fault, nor in his  
 power to remedy, must marry a cast wench. *Swift.*

Their understandings are cooped up in narrow  
 bounds; so that they never look abroad into other  
 provinces of the intellectual world. *Watts.*

His mien was aukward; graces he had none;  
 Provincial were his notions and his tone. *Harte.*

PROVINCE, in Roman antiquity, was a country  
 of considerable extent, which, upon being en-  
 tirely reduced under the Roman dominion, was  
 new-modelled according to the pleasure of the  
 conquerors, and subjected to the command of  
 annual governors, sent from Rome, being obliged  
 to pay such taxes and contributions as the senate  
 thought fit to demand. Of these countries, that  
 part of France next the Alps was one, and re-  
 tained the name of Provence till the Revolution.  
 Nicod derives the word a procul vivendo, living  
 afar off; but it is better derived from pro and  
 vinco, I overcome.

PROVINCE, in geography, is a division of a  
 kingdom or state, comprising several cities, towns,  
 &c., all under the same government, and usually  
 distinguished by the extent either of the civil or  
 ecclesiastical jurisdiction. The church distin-  
 guishes its provinces by archbishoprics; in which  
 sense, England is divided into two provinces,  
 Canterbury and York.

PROVINCE ISLAND, a fertile island in the De-  
 laware, six miles below Philadelphia.

PROVINCETOWN, a post town of Barnstable  
 county, Massachusetts, near Cape Cod; forty-  
 four miles north-east of Barnstable, and 116  
 south-east of Boston. It is situated on the hook  
 of Cape Cod, three miles south-east of Race  
 Point. The harbour, which is one of the best  
 in the state, opens to the southward, and has suf-  
 ficient depth of water for any vessels. The  
 houses are of one story, and, in order to prevent  
 their being buried in the sand, are set on piles,  
 that the driving sands may pass under them.  
 The inhabitants depend almost wholly on the  
 fisheries for subsistence; raise nothing on their  
 lands, and are dependent on Boston and the



neighbouring towns, for every vegetable production. They keep a few cows, which obtain a scanty subsistence from the beach grass and marshes.

**PROVINS**, a post-town of the department of the Seine-et-Marne, France, and the chief place of a sub-prefecture of the same name, containing 5600 inhabitants, and having a lower court of judicature, a chamber of commerce, an agricultural society, and a communal college. This town is situated on the declivity and at the foot of a lofty hill, watered by the little rivers of Durtein and Vouzie, which turn about sixty flour-mills in the neighbourhood. It is well built, and divided into the Upper and Lower Town; most of the streets are wide, clean, and airy; but it is not peopled in proportion to its size. It was fortified in ancient times, and there are still to be seen in the Upper Town the remains of a strong castle. Both parts of the town are encompassed with walls in a pretty good state of preservation. It is also almost encircled with boulevards, which form majestic bowers over a fountain of mineral-water, of a ferruginous quality. In 1780 a canal was commenced, for the purpose of rendering the little river Vouzie navigable; the accomplishment of this enterprise, as the canal would communicate with the Seine near Bray, would be of the highest importance to this town.

Here are manufactures of linsey-woolsey, earthenware, and conserve of roses; there are also numerous flour-mills, tan-yards, and bark mills, tile and lime-kilns. The trade consists in corn and flour for the Paris market, Provins roses for medicinal purposes, cultivated in this neighbourhood for centuries; wool, leather, and mineral-waters. The most remarkable public places are, the mineral-spring, the walks, and the extremity of the hill, on which the town is built, the ruins of an ancient fort, supposed to be of Roman construction, from which there is a very extensive prospect. Provins is thirty-seven miles east of Melun, thirteen north-west of Nogent, and sixty-three south-east of Paris.

**PROVISION**, *n. s.* } Fr. *provision*; Lat. *provisio, provisio*. The }  
**PROVISIONAL**, *adj.* } *provisio, provisio*. The }  
**PROVISIONALLY**, *adv.* } act of providing; }  
**PROVISIO**, *n. s.* } care; things provided }  
 or measures taken beforehand; stock, particularly of food; terms settled: provisional means provided for the present only; temporary: the adverb corresponding: proviso, stipulation; expressed condition; caution or care taken.

Kalander knew that *provision* is the foundation of hospitality, and thrift the fewel of magnificence.

*Sidney.*

This *provisio* is needful, that the sheriff may not have the like power of life as the marshal hath.

*Spenser*

Mendoza advertised, that he would valiantly defend the city, so long as he had any *provision* of vicuals.

*Knolles.*

He doth deny his prisoners,

But with *provisio* and exception,

That we, at our own charge, shall ransom strait His brother-in-law.

*Shakspeare. Henry IV.*

Five days we do allot thee for *provision*,

To shield thee from disasters of the world.

*Shakspeare.*

He preserved all points of humanity, in taking

order and making *provision* for the relief of strangers distressed.

*Bacon.*

This law was only to reform the degenerate English, but there was no care taken for the reformation of the mere Irish, no ordinance, no *provisions* made for the abolishing of their barbarous customs.

*Davies on Ireland.*

Under whose chin nature hath fastened a little bag, which she hath also taught him to use as a store-house; for in this, having filled his belly, he preserveth the remnant of his *provision*.

*Heulin.*

He caused *provisions* to be brought in. *Clarendon.*

*Provisions* laid in large for man or beast. *Milton.*

In such abundance lies our choice,

As leaves a greater store of fruit untouched,

Still hanging incorruptible, till men

Grow up to their *provision*.

*Id.*

Religion lays the strictest obligations upon men, to make the best *provision* for their comfortable subsistence in this world, and their salvation in the next.

*Tillotson.*

The prudent part is to propose remedies for the present evils, and *provisions* against future events.

*Temple.*

The abbot of St. Martin was born, was baptised, and declared a man *provisionally*, till time should show what he would prove, nature had moulded him so untowardly.

*Loche.*

David, after he had made such vast *provision* of materials for the temple, yet, because he had dipt his hands in blood, was not permitted to lay a stone in that sacred pile.

*South.*

Some will allow the church no further power than only to exhort, and this but with a *provisio*, too, that it extends not to such as think themselves too wise to be advised.

*Id.*

The commenda semestris grew out of a natural equity, that, in the time of the patron's respite given him to present, the church should not be without a *provisional* pastor.

*Ayliffe.*

**PROVOKE**' , *v. a. & v. n.* } Fr. *provoquer* ;

**PROVOCATION**, *n. s.* } Spanish *provocar* ;

**PROVOCATIVE**, } Lat. *provocare, provo-*

**PROVOKER**, } *voco*. To excite ;

**PROVOKINGLY**, *adv.* } rouse to energy ;

rouse or excite to anger; enrage; offend; challenge; induce; promote; move: as a verb neuter, to produce anger; and (a Latinism) to appeal: provocation is, the act or cause which excites to anger; excitement; appeal: provocative, that which operates as an excitement of the appetite, in particular: provoker, one who excites anger or displeasure; promoter: provokingly, in a way to excite anger.

The Lord abhorred them, because of the *provoking* of his sons.

*Deuteronomy xxxii. 19.*

Ye *provoke* me unto wrath, burning incense unto other Gods.

*Jeremiah xlv. 8.*

To *provoke* unto love and to good works.

*Hebrews.*

The like effects may grow in all towards their pastor, and in their pastor towards every of them, between whom there daily and interchangeably pass in the hearing of God himself, and in the presence of his holy angels, so many heavenly acclamations, exultations, *provocations*, and petitions.

*Hooker.*

Drink is a great *provoker*; it *provokes* and *unprovokes*.

*Shakspeare.*

It is a fundamental law, in the Turkish empire, that they may, without any other *provocation*, make war upon Christendom for the propagation of their law.

*Bacon.*

When we see a man that yesterday kept a humiliation, to-day invading the possessions of his bre-

then, we need no other proof how hypocritically and *provokingly* he confessed his pride.

*Decay of Piety.*

If we consider man in such a loathsome and *provoking* condition, was it not love enough that he was permitted to enjoy a being? *Taylor.*

Though often *provoked*, by the insolence of some of the bishops, to a dislike of their overmuch ferocity, his integrity to the king was without blemish.

*Clarendon.*

Neither to *provoke*, nor dread

New war *provoked*.

*Milton.*

A practice which, to the shame of our age, is now so much in fashion, and with some men in vogue; the invoking God's name, appealing to his testimony, and *provoking* his judgment, upon any slight occasion, in common talk, with vain incogitancy, or profane boldness.

*Barrow.*

Arius and Pelagius durst *provoke*

To what the centuries preceding spoke. *Dryden.*

I neither fear, nor will *provoke* the war. *Id.*

He now *provokes* the sea-gods from the shore:

With envy Triton heard the martial sound,

And the bold champion for his challenge drowned.

*Id.*

Tempt not my swelling rage

With black reproaches, scorn and *provocation*.

*Smith.*

We may not be startled at the breaking of the exterior earth; for the face of nature hath *provoked* men to think of, and observe such a thing. *Burnet.*

As, in all civil insurrections, the ringleader is looked on with a peculiar severity, so, in this case, the first *provoker* has double portion of the guilt.

*Government of the Tongue.*

There would be no variety of taste to solicit his palate and occasion excess, nor any artificial *provocations* to relieve satiety.

*Addison.*

A *provocation* is every act, whereby the office of the judge or his assistants is asked; a *provocation* including both a judicial and an extrajudicial appeal.

*Ayliffe.*

One Petro covered up his patient with warm cloaths, and when the fever began a little to decline, gave him cold water to drink till he *provoked* sweat.

*Arbuthnot.*

Agamemnon *provokes* Apollo against them, whom he was willing to appease afterwards.

*Pope.*

If the performance of a writer thus distressed is not perfect, its faults ought surely to be imputed to a cause very different from want of genius, and must rather excite pity than *provoke* censure.

*Johnson.*

When gifts perverted, or not duly prized,

Pleasure o'ervalued, and his grace despised

*Provoke* the vengeance of his righteous hand,

To pour down wrath upon a thankless land;

He will be found impartially severe,

Too just to wink, or speak the guilty clear.

*Cowper.*

Garrulity, attended with immoderate fits of laughing, is no uncommon case, when the *provocation* thereunto springs from jokes of a man's own making.

*Cumberland.*

PROVOST, *n. s.* } Sax. *prapart*; Fr. *provost*.  
PROVOSTSHIP. } *vost*; Ital. *provosto*; Lat. *propositus*. The chief of any body, civil or military: the office of a provost.

Kingston, *provost* marshal of the king's army, was deemed not only cruel, but inhuman in his executions.

*Hayward.*

C. Piso first rose, and was afterwards advanced to the *provostship* of Rome by Tiberius.

*Hakewill.*

He had particular intimacy with Dr. Potter, *provost* of Queen's College.

*Fell.*

The *Provost* of a city or town is the chief municipal magistrate in several trading cities, particularly Edinburgh, Paris, &c., being much the same with mayor in other places. He presides in city courts, and, together with the bailies, who are his deputies, determines in all differences that arise among citizens. The *provost* of Edinburgh is called lord; and the same title is claimed by the *provosts* of Perth and Glasgow. The former calls yearly conventions of the royal boroughs to Edinburgh by his *missives*, and is, *ex officio*, president of the convention when met.

PROVOST GENERAL of the marines, a *ci-devant* French officer, whose duty it was to prosecute the marines when guilty of any crime, and to make report thereof to the council of war; besides a marine *provost* in every vessel, who was a kind of jailor, and took the prisoners into his care, and kept the vessel clean.

PROVOST MARTIAL OF AN ARMY is an officer appointed to seize and secure deserters, and all other criminals. He is to hinder soldiers from pillaging, to indict offenders, and see the sentence passed on them executed. He also regulates the weights and measures, and the price of provisions, &c., in the army. For the discharge of his office, he has a lieutenant, a clerk, and a troop of marshalmen on horseback, as also an executioner.

PROVOST OF THE MARSHALS was a kind of lieutenant of the marshals of France: of these there were 180 seats in France; their chief jurisdiction regarded highwaymen, footpads, house-breakers, &c.

PROVOST OF A UNIVERSITY OR COLLEGE, a title given to the head of King's College, Cambridge, and of Trinity College, Dublin, and also to the president of a college in the United States.

PROW, *n. s.* Fr. *proue*; Span *proa*; Lat. *prora*. The head or forepart of a ship.

The sea-victory of Vespasian was a lady holding a palm in her hand, at her foot the *proa* of a ship.

*Peacham on Drawing.*

Straight to the Dutch he turns his dreadful *proa*,  
More fierce th' important quarrel to decide.

*Dryden.*

PROWESS, *n. s.* } Fr. *prouesse*; Ital. *pro-*  
PROWEST, *adj.* } *dezza*; Span. *proeza*. Bravery; military valor: *prowest*, bravest; valiant: an obsolete barbarism.

Men of such *prowest*, as not to know fear in themselves, and yet to teach it in others that should deal with them; for they had often made their lives triumph over most terrible dangers, never dismayed, and ever fortunate.

*Sidney.*

I hope

That your wisdom will direct my thought,  
Or that your *prowest* can me yield relief. *Spenser*

They be two of the *prowest* knights on ground,  
And oft approv'd in many a hard assay,  
And eke of surest steel, that can be found,  
Do arm yourself against that day them to confound.

*Id.*

Nor should thy *prowest* want praise and esteem,  
But that 'tis shewn in treason.

*Shakspeare. Henry VI.*

Those are they

First seen in acts of *prowest* eminent,  
And great exploits, but of true virtue void. *Milton.*

The fairest of her sex, Angelica,  
His daughter, sought by many *provest* knight. *Id.*  
These were the entertainments of the softer nations, that fell under the virtue and *provest* of the two last empires. *Temple.*

The vigour of this arm was never vain,  
And that my wouted *provest* I retain,  
Witness these heaps of slaughter on the plain. *Dryden.*

**PROWL**, *v. a. & v. n.* } The old dictionaries  
**PROWLER**, *n. s.* } write *prole*, which  
Casaubon derives from *προαλης*, ready, quick. Skinner, from *prosler*, a diminutive formed by himself from *proier* to prey, French; 'perhaps,' says Johnson, 'it may be formed, by accidental corruption, from *patrol*.' Thomson, Fr. *proioler*, to rove over.

The champion robbeth by night,  
And *proweleth* and filcheth by daie. *Tusser.*  
He *prows* each place, still in new colours deck't,  
Sucking one's ill, another to infect. *Sidney.*

Nor do they bear so quietly the loss of some parcels confiscated abroad, as the great detriment which they suffer by some *prowing* vice-admiral or public minister. *Raleigh.*

As when a *prowing* wolf,  
Whom hunger drives to seek new haunt for prey. *Milton.*

On church-yards drear,  
The disappointed *prowers* fall, and dig  
The shrouded body from the grave. *Thomson.*

**PROXIMATE**, *adj.* } Lat. *proximus*. Next  
**PROXIMATELY**, *adv.* } in the series of ratiocination; near and immediate: this is the signification of both adjectives; the adverb and noun-substantive corresponding.

When kingdoms have customably been carried by right of succession, according to *proximity* of blood, the violation of this course hath always been dangerous. *Hayward.*

If he plead *proximity* of blood.  
That empty title is with ease withstood. *Dryden.*  
Add the convenience of the situation of the eye, in respect of its *proximity* to the brain, the seat of common sense. *Ray.*

Writing a theory of the deluge, we were to shew the *proximate* natural causes of it. *Burne.*

I can call to my assistance  
*Proximity*, mark that! and distance. *Prior.*  
The consideration of our mind, which is incorporeal, and the contemplation of our bodies, which have all the characters of excellent contrivance; these alone easily and *proximately* guide us to the wise author of all things. *Bentley.*

Must we send to stab or poison all the popish princes, who have any pretended title to our crown by the *proximity* of blood? *Swift.*

A syllogism is made up of three propositions, and these of three terms variously joined: the three terms are called the remote matter of a syllogism, the three propositions the *proxime* or immediate matter of it. *Watts's Logick.*

**PROXY**, *n. s.* Contracted from *procuracy*. Agency of another; the substitution of another: hence the appearance of a representative, or person substituted.

We must not think that we, who act only as their *proxies* and representatives, may do it for them. *Kettlewell.*

A wise man will commit no business of importance to a *proxy*, where he may do it himself. *L'Estrange.*

None acts a friend by a deputy, or can be by *proxy*. *South.*

Had Hyde thus sat by *proxy* too,  
As Venus once was said to do,  
The painter must have searched the skies,  
To match the lustre of her eyes. *Granville.*

**PRUCE**, *n. s.* From Prussia or Pruzzi. See **PRUSSIA**. Prussian leather.

Some leathern buckles use  
Of folded hides, and leathern shields of *pruce*. *Dryden.*

**PRUDE**, *n. s.* } Fr. *prude*; Lat. *prudential*.  
**PRUDISH**, *adj.* } A woman affectedly nice and scrupulous: affectedly grave or nice.

The graver *prude* sinks downward to a gnome,  
In search of mischief, still on earth to roam. *Pope*  
Not one careless thought intrudes,  
Less modest than the speech of *prudes*. *Swift.*  
I know you all expect, from seeing me,  
Some formal lecture, spoke with *prudish* face. *Garrick.*

**PRUDENCE**, *n. s.* } Fr. *prudence*; Lat. *prudencia*. Wisdom in  
**PRUDENT**, *adj.* } practice; discretion:  
**PRUDENTIAL**, *adj.* } prudent is the corresponding adjective:  
**PRUDENTIALLY**, *adv.* } prudential is, according to rules of prudence, the adverb, and noun-substantive corresponding: prudentials, maxims or principles of prudence: prudently, discreetly; judiciously.

I have seen a son of Jesse, that is a man of war, and *prudent* in matters. *1 Samuel xvi. 18.*

I wisdom dwell with *prudence*. *Proverbs.*  
These laws were so *prudently* framed, as they are found fit for all succeeding times. *Bacon.*

Under *prudence* is comprehended that discreet, apt, suiting, and disposing as well of actions as words, in their due place, time, and manner. *Peacham.*

If the probabilities on the one hand should somewhat preponderate the other, yet if there be no considerable hazard on that side, which has the least probability, and a very great apparent danger in a mistake about the other: in this case, *prudence* will oblige a man to do that which may make most for his own safety. *Wilkins.*

So steers the *prudent* crane  
Her annual voyage. *Milton.*

*Prudence* is principally in reference to actions to be done, and due means, order, season, and method of doing or not doing. *Hale.*

Being incapable rightly to judge the *prudentiality* of affairs, they only gaze upon the visible success, and thereafter condemn or cry up the whole progression. *Broune.*

Motives are only *prudential*, and not demonstrative. *Tillotson.*

Such deep designs of empire does he lay  
O'er them, whose cause he seems to take in hand;

And *prudently* would make them lords at sea,  
To whom with ease he can give laws by land. *Dryden.*

He acts upon the surest and most *prudential* grounds, who, whether principles which he acts upon prove true or false, yet secures a happy issue to his actions. *South.*

If he acts piously, soberly, and temperately, he acts *prudentially* and safely. *Id.*

These virtues, though of excellent use, some *prudential* rules it is necessary to take with them in practice. *Rogers.*

Many stanzas, in poetick measures, contain rules relating to common *prudentials*, as well as to religion.  
Watts.

*Prudent* men lock up their motives; letting familiar have a key to their heart as to their garden.  
Shenstone.

Adieu, dear amiable youth!  
Your heart can ne'er be wanting:  
May *prudence*, fortitude, and truth,  
Erect your brow undaunting.  
Byron.

**PRUDENCE**, in ethics, may be defined an ability of judging what is best, in the choice both of ends and means. According to the definition of Cicero, *De Officiis*, lib. i. c. 43, *prudence* is the knowledge of what is to be desired or avoided. Accordingly, he makes *prudencia* (*De Legibus*, lib. i.) to be a contraction of *providentia*, or foresight. Plato calls this the leading virtue; and Juvenal *Stat. x.* observes, *Nullum numen abest si sit prudentia.*

**PRUDENTIUS**, or **AURELIUS PRUDENTIUS CLEMENS**, a celebrated Christian poet, under Theodosius the Great, born in Spain, A. D. 348. He was first an advocate, and afterwards a judge; he then became a soldier, and at length obtained an honorable employment at court. We have a great number of his poems, which, from the choice of his subjects, may be termed Christian Poems; but the style is barbarous, and very different from the purity of the Augustan age. The best editions of his works are those of Amsterdam, in 1667, with Heinsius's notes, and Paris in 1687, in usum Delphini.

**PRUNE**, *v. a., v. n., &* } Of unknown derivation. — Johnson.  
**PRUNER**, } *n. s.* } Fr. *provin*, of Latin  
**PRUNINGHOOK**, } } *propago*, an exuberant shoot.—Thomson. To lop; divest trees of their superfluities; dress; prink: a dried plum; one who crops trees: pruning-hook and pruning-knife are instruments of his art.

His royal bird  
*Prunes* the immortal wing, and cloys his beak.  
Shakespeare.

Many birds *prune* their feathers; and crows seem to call upon rain, which is but the comfort they receive in the retenting of the air.  
Bacon.

In drying of pears and *prunes* in the oven, and removing of them, there is a like operation. *Id.*

So lopped and *pruned* trees do flourish fair. *Davies.*  
Some sitting on the beach to *prune* their painted breasts.  
*Drayton.*

Lest thy redondant juice  
Should fading leaves, instead of fruits, produce,  
The *pruner's* hand with letting blood must quench  
Thy heat, and thy exub'rant parts retrench.  
*Denham.*

What we by day  
Lop overgrown, or *prune*, or prop, or bind,  
One night with wanton growth derides,  
Tending to wild. *Milton's Paradise Lost.*  
Horace will our superfluous branches *prune*,  
Give us new rules, and set our harp in tune.  
*Waller.*

Every scribbling man  
Grows a fop as fast as ere he can,  
*Prunes* up, and asks his oracle the glass,  
If pink or purple best become his face. *Dryden.*

Let thy hand supply the *pruningknife*,  
And crop luxuriant stragglers, *Id.*  
No plough shall hurt the glebe, no *pruninghook*  
the vine. *Id.*

VOL. XVIII.

The cyder land obsequious still to thrones,  
Her *pruninghooks* extended into swords. *Philips.*  
You have no less right to correct me than the same hand that raised a tree has to *prune* it. *Pope.*

**PRUNELLA**, in botany, self-heal, a genus of the gymnospermia order, and didynamia class of plants; natural order fortieth, verticillatæ. The filaments are bifurcated, with an anthera only on one point; the stigma is bifid. The chief species is

*P. vulgaris*, the herb self-heal. The stem is erect, and eight or ten inches high. The leaves grow on foot-stalks, are ovato-oblong, slightly indented and somewhat hairy. The bractæ are heart-shaped, opposite, and fringed. The flowers are white and purplish, grow in dense spikes, and are terminal. The plant is perennial; grows wild in meadows and pasture grounds, and flowers in June and July. It is recommended as a mild astringent and vulnerary, in spitting of blood and other hæmorrhagies and fluxes; and in gargles against aphthæ and inflammations of the fauces. Its taste is slightly austere and bitterish; and this is more perceptible in the flowery tops than in the leaves, though the latter are chiefly prescribed.

**PRUNELLO**, *n. s.* Barb. Lat. *prunella*. A kind of stuff of which clergymen's gowns are made.

Worth makes the man, and want of it the fellow,  
The rest is all but leather or *prunello*. *Pope.*

**PRUNING**, in gardening and agriculture, is the lopping off the superfluous branches of trees. Pruning, or the amputation of part of a plant with the knife or other instrument, says Mr. Loudon, is practised for various purposes, but chiefly on trees of the fruit-bearing kinds. Of two adjoining and equal sized branches of the same tree, if the one be cut off, that remaining will profit by the sap which would have nourished the other, and both the leaves and the fruits which it may produce will exceed their natural size. If part of a branch be cut off which would have carried a number of fruits, those which remain will fix better, and become larger. The objects of pruning may be reduced to the following: promoting growth and bulk; lessening bulk; adjusting the stem and branches to the roots; renewal of decayed plants or trees; and removal or cure of diseases.

Pruning, for promoting the growth and bulk of a tree, is the simplest object of pruning, and is that chiefly which is employed by nurserymen with young trees of every description. The art is to cut off all the weak lateral shoots, that the portion of sap destined for their nourishment may be thrown into the strong ones. In some cases, besides cutting off the weak shoots, the strong ones are shortened, in order to produce three or four shoots instead of one. In general, mere bulk being the object, upright shoots are encouraged rather than lateral ones; excepting in the case of trained trees, where shoots are encouraged.

Pruning for lessening the bulk of the tree is also chiefly confined to nursery practice, as necessary to keep unsold trees portable. It consists in little more than what is technically called heading down; that is, cutting off the leading

P

shoots within an inch or two of the main stem, leaving, in some cases, some of the lower lateral shoots. Care is taken to cut to a leaf bud, and to choose such from among the side, upper, or under buds of the shoot, according as the succeeding year's shoots may be wanted, in radiated lines from the stem, or in oblique lines in some places to fill up vacancies. It is evident that this unnatural operation persisted in for a few years must render the tree knotty and unsightly, and in stone-fruits, at least, it is apt to generate canker and gum.

In rearing trees planted for timber, it is desirable to throw the timber produced, as much as possible, into long compact masses; and hence pruning is employed to remove the side branches, and encourage the growth of the bole or stem. Where this operation is begun when the trees are young, it is easily performed every two or three years, and the progress of the trees under it is most satisfactory; when, however, it is delayed till they have attained a size, it will sometimes prove injurious. It is safer in such cases to shorten or lessen the size of lateral branches, rather than to cut them off close by the stem, as the large wounds produced by the latter practice either do not heal at all, or not till the central part is rotten, and has contaminated the timber of the trunk. Where timber-trees are planted for shelter or shade, it is evident, pruning must be directed to clothing them from the summit to the ground, with side branches; but in avenues, and hedge-row trees, it is generally desirable that the lowest branches should be a considerable distance from the ground. In all cases, the superfluous parts are to be cut off with a clean section, near a bud or shoot if a branch is shortened, or close to the trunk if it is entirely removed, in order that it may more easily heal.

Pruning for adjusting the stem and branches to the roots is almost solely applicable to transplanted trees, in which it is an essential operation; and should be performed in general in the interval between removal and replanting, when the plant is entirely out of the ground; if the roots have been broken or bruised, in any of their main branches or ramifications, the pruner, estimating the quantity of root of which the plant is deprived by the sections of fracture and other circumstances, peculiar and general, will be able to form a notion of what was the bulk of the whole roots before the tree was undisturbed. Then he may state the question of lessening the top to adjust it to the roots, thus:— as the whole quantity of roots which the tree had before removal is to the whole quantity of branches which it now has, so is the quantity of roots which it now has to the quantity of top which it ought to have. In general, bearing-wood and weak shoots should be removed, and the stronger lateral and upright shoots, with leaf or shoot-eyes, left.

Pruning for renewal of the head is performed by cutting over the stem a little way, say its own thickness above the collar, or the surface of the ground. This practice applies to old osier-beds, coppice woods, and to young forest-trees. Sometimes also it is performed on old, or ill-

thriving fruit-trees which are headed down to the top of their stems. This operation is performed with the saw, and better after scarification, as in cutting off the broken limb of an animal. The live section should be smoothed with the chisel or knife, covered with the bark, and coated over with grafting-clay, or any convenient composition, which will resist drought and rain for a year. Those who are advocates for pruning when the sap is dormant, will not of course be able to perform the operation of scarification, and covering the section with bark.

Pruning for curing diseases has acquired much celebrity since the time of Forsyth, whose amputations and scarifications for the canker, together with the plaster or composition which he employed to protect the wounds from air, are treated of at large in his Treatise on Fruit-Trees. Almost all vegetable diseases either have their origin in the weakness of the individual, or induce a degree of weakness; hence to amputate a part of a diseased tree is to strengthen the remaining part, because, the roots remaining of the same force, the same quantity of sap will be thrown upwards as when the head and branches were entire. If the disease is constitutional, or in the system, this practice may probably, in some cases, communicate to the tree so much strength as to enable it to throw it off; if it be local, the amputation of the part will at once remove the disease, and strengthen the tree.

PRUNUS, in botany, a genus of the monogynia order, and icosandria class of plants; natural order thirty-sixth, pomaceæ: CAL. quinquefid, inferior; there are five petals; the fruit is a plum, having a kernel with prominent sutures. There are thirty-three species, of which six are cultivated in Britain: they are originally natives of America and Siberia.

1. *P. armeniaca*, or apricot tree, grows twenty feet high, with a large spreading head, having reddish shoots, large nearly heart-shaped leaves, and close-sitting pale red flowers rising all along the sides of the young branches; succeeded by large roundish fruit of a yellow and reddish color in different varieties. The fruit and kernels excite when eaten a continued head-ache: the kernels, infused in brandy, communicate an agreeable flavor.

2. *P. avium*, the great wild cherry-tree, grows forty or fifty feet high, having oval spear-shaped leaves, downy underneath, with umbellate sessile clusters of white flowers, succeeded by small round fruit of different properties in the varieties.

3. *P. Canadensis*, the Canada dwarf bird cherry, grows but four or five feet high, branching horizontally near the ground with smooth branches; broad, spear-shaped, rough, downy leaves, without glands; and long clusters of white flowers, succeeded by small, round, berry-like, black fruit, ripe in autumn.

4. *P. cerasus*, the common cherry-tree, grows twenty feet or more in height, garnished with oval clusters of lanceolate, smooth leaves, umbellate flowers, succeeded by clusters of red roundish fruit of different sizes and properties in the varieties. The cherry trees afford an almost endless variety; all differing in some re-

spect in the manner of shooting, leaves, flowers, or fruit: two in particular demand admission into the pleasure-garden; the double-blossomed and the red-flowering. The pleasing show the common cherry tree makes when in blow is known to all; but that of the double-blossomed is much more beautiful. It blossoms like the other in May; the flowers are produced in large and noble clusters; for each separate flower is as double as a rose, is very large, and placed on long and slender foot-stalks, so as to occasion the branches to have an air of ease and freedom. They are of a pure white; and the trees are so profusely covered with them, that when viewed at a distance they have been compared to balls of snow. But by the multiplicity of the petals the organs of generation are destroyed; so that those flowers which are really full are never succeeded by any fruit. The red-flowering cherry tree differs in no respect from the common cherry tree, only that the flowers are of a pale red color, and by many are esteemed on that account. Besides the ornament and utility afforded by the flowers and fruit of the cherry, its timber is a further inducement for propagating it; more especially that of the small black wilding sort; which will grow, in a soil and situation it affects, to be a large tree; which, if taken in its prime, will yield perhaps not less than a ton of valuable materials, peculiarly adapted to the purposes of furniture. The grain is fine, and the color nearly approaching to that of mahogany.

5. *P. domestica*, the common plum tree, grows twenty or thirty feet high, garnished with oval, spear-shaped leaves, and with the pedunculi for the most part single, terminated by flowers, succeeded by plums of many different colors, sizes, and shapes in the varieties.

6. *P. insititia*, wild plum, or bullace tree, grows twelve or fifteen feet high; the branches somewhat spinous; the leaves oval, hairy underneath; and the pedunculi by pairs, terminated by white flowers, succeeded by small, round, plum-like, fruit of different colors in the varieties.

7. *P. padus*, the common bird-cherry tree, grows fifteen or twenty feet high, of a shrub-like growth, with a spreading head, large, oblong, rough, serrated leaves, having two glands at the back of the base like the other, and with shorter, more compact clusters of flowers, succeeded by large red fruit. This grows wild in hedges in the north parts of England.

8. *P. spinosa*, black thorn, or sloe tree, grows ten or twelve feet high, very branching and bushy quite from bottom, armed with strong, sharp spines, small, spear-shaped, smooth leaves, pe-

dunculi growing singly, terminated by flowers, succeeded by small round cherries in autumn. It grows wild every where in hedges and woods; and is very proper for planting field hedges, being of very quick and close growth.

9. *P. Virginiana*, the Virginian bird-cherry, grows thirty feet high, dividing into a very branchy head, having a dark purple bark, oval, slightly serrated, shining green leaves, having two glands at the fore part of the base, and long clusters of white flowers, succeeded by small, round, berry-like, black fruit. All the different varieties of plums have at first been raised from the stones, and are afterwards preserved by budding and grafting on any plum-stock. The same method is applicable to cherries; only these are grafted to most advantage upon stocks of the wild black and red cherry raised from the stones of the fruit. The apricot-trees are propagated by budding on any kind of plum-stocks.

PRURIENCE, *n. s.* } Latin *prurio*. An  
PRURIENCY. } itching or great desire  
or appetite to any thing.

There is a *prurience* in the speech of some,  
Wrath stays him, or else God would strike him dumb:  
His wise forbearance has their end in view,  
They fill their measure, and receive their due

*Cowper.*

PRUSA, in ancient geography, a town situated at Mount Olympus in Mysia, built by Prusias, who waged war with Cræsus and Cyrus. It was the capital of Bithynia, in Asia Minor.

PRUSIAS II., king of Bithynia, made an alliance with the Romans, but afterwards receiving Hannibal kindly, by his advice, made war on Eumenes, king of Pergamus, whom he defeated. Eumenes complained to the Romans, on which queen Flaminius was sent against him; whereupon Prusias rendered himself for ever infamous by offering to deliver up Hannibal, which that hero prevented by a voluntary death. Prusias then restored Eumenes his provinces; but became such a servile flatterer of the Romans that his subjects dethroned him, made his son Nicomedes king; and, on his flight to Nicomedia, assassinated him, A. A. C. 149.

PRUSIAS, in geography, a town of Bithynia, anciently called Cios, from a cognominal river, and giving name to the Sinus Cianus of the Propontis; rebuilt by Prusias the son of Zela after having been destroyed by Philip the son of Demetrius. It stood on the Sinus Cianus, at the foot of Mount Arganthonius. Of this place was Asclepiades, surnamed Prusicus, the famous physician.

## PRUSSIA.

PRUSSIA, an extensive kingdom of modern Europe, is by some writers said to have derived that name (through Prussia proper) from the Pruzzi, a tribe of the ancient Scythians or Sarmatians. Others suppose it derived from the word Russia, united with the Slavonic word *po*, signifying near. Po-Russia, easily modified into

Prussia, would thus imply the people or country near Russia. This kingdom occupies a great part of northern Germany, bordering on the south of the Baltic; and extends, with little interruption, from the confines of Lithuania to those of the Netherlands: being washed at one extremity by the Neimen, and at the other by

the Rhine and the Moselle. Or it is bounded by Russia and the Baltic on the north; Poland on the east; the Austrian empire and the kingdom of Saxony on the south; the Netherlands on the west; and the kingdom of Hanover, with the duchy of Mecklenburg, on the north-west. From north-east to south-west it measures about 750 miles. Its breadth is very unequal, and in some places it does not exceed 100 miles: in others it is 300. In one place it reaches from the Baltic to the southern point of Silesia, below 50° of latitude. The extremity of the grand duchy of the Lower Rhine, which now forms a part of the kingdom, also stretches nearly to the 49°.

According to Hoffmann, the whole extent of the Prussian dominions includes an area of

115,795 English square miles, or 74,108,800 British statute acres. The population, in 1817, was 10,556,570; which is about ninety-one persons for each square mile. The following statement shows the rapid increase of this population:—In 1688 it was stated at 1,500,000; in 1713 it was 1,620,000; at the death of Frederick William, in 1740, it had increased to 2,200,000; and in 1786 it was 5,800,000. On the accession of his present majesty, in 1797, the population of his dominions was 8,700,000.

Part of the Prussian monarchy, situated within the confines of Germany, forms a portion of the Germanic confederation. The other part is entirely independent of that body. The whole is now divided into ten provinces, i. e.

#### I. GERMAN PROVINCES.

Provinces.	Extent in Eng. sq. miles.	Population.	Chief towns.	No. of inhabitants.
1. Brandenburg	17,227	1,297,795	Berlin	236,830
2. Pomerania	13,018	700,766	Stettin	20,000
3. Silesia	16,560	1,992,598	Breslau	90,090
4. Duchy of Saxony	10,411	1,214,219	Magdeburg	44,049
5. Westphalia	8,648	1,074,079	Munster	13,000
6. Duchy of Juliers, Cleves, and Berg	3,634	935,040	Cleves	5,000
7. Grand duchy of the Lower Rhine	6312	972,724	Cologne	64,099

#### II. PROVINCES OUT OF GERMANY.

Provinces.	Extent in Eng. sq. miles.	Population.	Chief towns.	No. of inhabitants.
8. Eastern Prussia	16,146	919,580	Konigsberg	67,941
9. Western Prussia	10,695	581,971	Dantzic	61,902
10. Grand duchy of Posen	12,374	847,800	Posen	15,000

Total (exclusive of lakes and waters) 115,025 10,536,572

A level and rather low surface is the predominant character of this country; but Silesia, which is divided from Moravia and Bohemia by the Carpathians, is frequently diversified by the rapid interchange of hill and valley. The eastern side, however, participates with the grand duchy of Posen in all the properties of an extensive plain, which, with the other regions between it and the Baltic, constitute the grand basin of the Oder. According to Busching, the principal detached hills in Silesia are Spitzberg and Gratzberg. The countries approaching the Baltic are level and marshy. Many parts of the Prussian landscape, particularly Prussia Proper, abound with forests, and in the districts of Silesia bordering on Hungary noble woods clothe the range of hills that forms the barrier. The south-western regions, in the vicinity of the Rhine, also contain many forests, and morasses and pools abound in various parts.

Most of the large rivers which intersect these dominions originate in foreign sources. The Oder and the Pregel, indeed, may be considered as Prussian rivers: the former, rising in the mountains in the northern part of Moravia, soon after enters the southern parts of Silesia, flows through the middle of that province, and crosses Brandenburg and Pomerania, falling into the Grass-Haff, after a course of nearly 400 miles. The Pregel originates near the south-east extremity of Prussia, and passes by Konigsberg into the northern end of the Frische-Haff. The Spree, rising in Saxony, flows through Berlin, and enters the Elbe. The Vistula and the Memel

likewise complete their course by flowing through this kingdom; the former into the Frische-Haff, and the latter into the Curische-Haff. The Netze and the Warta are two considerable rivers running from east to west, through the grand duchy of Posen, till they unite above Landsberg, and afterwards pour their waters into the Oder. The Weser, the Rhine, and the Moselle, with some of their tributary streams, intersect Western Prussia. The Netze and the Vistula are united by a canal, which enters the latter river near Bromberg. Smaller canals intersect some parts of the kingdom: as one which connects the capital with the Oder on the east, and another with the Elbe on the west.

The lakes and pools of Prussia are so numerous as to add considerably to the insalubrity of the climate. These are chiefly in the eastern regions, and are supposed to exceed 400 in number: many are also spread over the surface of Pomerania, Brandenburg, and the western regions. One of the largest of these is the Spelding-See, in the south-east of Prussia Proper; and, including its several creeks, spreads more than twenty English miles. Besides these, the kingdom of Prussia presents many singular Haffs or sheets of water, at the estuaries of some of its principal rivers. One of these, denominated the Grass-Haff, is situated in the north-west point of Pomerania, at the mouth of the Oder. A second, the Frische-Haff, extends from Elbing to Konigsberg, and is only separated from the Baltic, to which it is nearly parallel, by a narrow slip of land. It is about







Drawn by J. Assheton.

London: Published by...



**PRUSSIA.**

British Miles.  
0 20 40 60 80

Engraved on Steel by J. Shury.



seventy English miles in length, and from three to ten in breadth; but not of sufficient depth to admit ships of large burden. The bank which separates it from the Baltic is said to have been thrown up by storms about the end of the twelfth century. Another of these gulfs commences a few miles north-east of the last, stretches northward, and enters the sea opposite Memel. This is the Curische-Haff, and is broadest at its southern extremity, but very narrow towards the opposite end. Its length is nearly sixty English miles, and its greatest breadth about thirty. The space between it and the sea is likewise very narrow. It is subject to frequent storms.

Prussia, amidst great variety of climate, must be considered as on the whole a cold and damp country. The lakes, forests, and marshes, render some places particularly unhealthy; as, for instance, Prussia Proper, where the autumn is often deluged with rain, and the winter is very long. Silesia is the most pleasant and healthy province, but in the south-western parts, which border on the Carpathians, the winters are severe. Some of the most favored districts produce the grape, but not in perfection. Brandenburg and Pomerania are principally sandy and marshy plains. The south-western regions enjoy a more favorable temperature.

Silesia is one of the most fertile of the old provinces, and portions of the lately acquired territory on the Rhine possess a genial soil as well as climate, requiring skilful culture to render them very productive. But in Brandenburg the soil is sandy and very barren: and other central parts of the country are marshy and totally unfit for culture.

We have not met with so able a sketch of the general agricultural state of Prussia as is furnished by Mr. Jacob in the course of his first Report on the Foreign Trade in Corn. He carefully examined the maritime, which are also the principal agricultural provinces of Prussia, i. e. East and West Prussia and Pomerania.

They appear by the official accounts, which he quotes, to have exported 447,183 quarters of wheat, and 1,218,916 quarters of rye, barley, and oats, beyond their own growth, in the last nine years, up to the end of 1824; exclusive of the year 1818, the returns of which, for East Prussia, are wanting, but which probably were 350,000 quarters of wheat, and 340,000 quarters of the other grains. It is possible, however, that some portion of this quantity may have been produced in the internal contiguous provinces of Posen, Silesia, and Brandenburg.

Before the year 1807 the landed estates in Prussia, as in most other parts of Europe, were in the possession of large proprietors. Many of them could only be held by such as were of noble birth; and the merchant, the manufacturer, or the artisan, however much money he might have accumulated, could not invest it in such land until he had obtained a patent of nobility. These restrictions were removed by the king, about the year 1807, when the French had overrun the country. A tenantry in our sense of the term was then, as it still is, almost unknown. The land was worked by a class of persons in some respects slaves; and in most respects but

little removed from that condition. In many cases they had an hereditary kind of right to some use of the land, such as to grow one crop of corn according to a prescribed course, whilst the lord had the right of pasture between the crops. These peasants were sold with the land, or descended to the heir, and were bound to perform certain labor or services for the lord. They could not, on the other hand, be dismissed from their holdings, nor had their superior any power over the property they might happen to be able to accumulate.

The conditions upon which the peasants held their portions of land were very various, some having a greater, and others a less share of the use of them; some doing greater, and others less service for them. By a series of legislative measures, which were enacted from 1807 to 1811, the whole of the enslaved peasants have become converted into freemen and freeholders. In some cases the holdings have been equally divided, and the peasant has his moiety in perpetuity. In cases where the lord's claims for personal services were more extensive, the peasant had a smaller share in the land. In some instances, compensations in money were settled by compact between the lords and the peasants, sometimes by the payment of a fixed sum, or by a security on the land allotted in perpetuity to the peasant, for the payment of such sum. Sometimes the peasant retained the whole of the land he had before used, paying to the lord the value of that portion which might otherwise have been given up to him. The successive measures by which the peasants were raised to the rank of freemen were not received by all with equal readiness. The lords were compelled, but the peasants were allowed to decline compliance; and, even to the present day, some few prefer the ancient mode of their holdings to that which the laws have allowed.

Although the foundation is laid for a new and better order of things, yet its effects on the agriculture of the country have not hitherto been fully realised. The abolition of personal services, and of hereditary ownership of such services, has been too recent for the full operation of the change of the parties from the relation of master and slave, to that of employer and employed, to produce the effect which is its natural tendency. It is obvious that all the operations of agriculture are still performed by the laborers with a listlessness and slovenly indolence which was natural to their former character, and which their new condition has not yet had time to remove.

The land in the three maritime provinces, as indeed in almost the whole of Prussia, may be considered as either in very large portions belonging to the nobility, or to the new class of proprietors; or as very small portions, such as under the ancient system were deemed sufficient for half the maintenance of the family of a peasant. There are but very few of that middle class of capitalists, resembling our farmers, who can hire land to that extent, which one able man can most advantageously manage, and, after stocking and working it, pay for the hire to the proprietor.

With some few exceptions, and those very few.

no rent is paid; but each occupier, whether a large or a small one, is his own landlord. The deviations from this general view are to be found, for the most part, on the banks of the great rivers, where meadows, either for the purpose of fattening cattle, or of saving hay, for the supply of large towns near the mouths of these rivers, are let to tenants for money rents.

The value of land generally is low, as may be inferred from the low price of produce, and of rents for what little is rented.

According to official documents it appears that the three maritime provinces of East Persia, West Prussia, and Pomerania, including in the latter the late Swedish territory, contains about 25,500,000 acres, or more than half the extent of England. By an official account, made up in 1821, the stock of cattle appeared to be as follows, at the latter end of the year 1819; viz.

556,839 horses and colts.  
1,171,434 oxen, cows, and calves.  
2,049,801 sheep and lambs,—and  
617,310 swine.

The lowest estimate of the stock of cattle in England gives three times this number of horses, and more than four times the number of cows and sheep, to the same extent of land; and most of those who have calculated on the subject have carried the proportion of cattle to surface in England much higher.

From this deficient stock of the animals, from which manure is derived, it will naturally be inferred that the increase of grain must be very small. Mr. Jacob was satisfied, from his observations, confirmed by the opinion of intelligent natives, that much of the land in cultivation could not yield on an average more than three times as much corn as the seed that had been sown. The calculations made by the most intelligent statistical enquirers, and the most observing calculators, have not estimated the average increase of the four kinds of grain, viz. wheat, rye, barley, and oats, taken together, to be more than four times the seed.

*Course of cultivation.*—The general course of cultivation is to fallow every third year, by ploughing three times, when designed for rye, or five times if intended for wheat, and allowing the land to rest without any crop during the whole of the year, from one autumn to the next. Most of the land is deemed to be unfit for the growth of wheat under any circumstances. Where it is deemed adapted to that grain, as much as can be manured from their scanty supply of that article is sown with wheat, and the remainder of the fallow ground with rye. The portion which is destined for wheat, even in the best farms, is thus very small; and, as on many none is sown, the whole of the land devoted to wheat does not amount to one-tenth of that on which rye is grown. Of late years the proportion of rye to wheat has been increasing. The first is an article of domestic consumption and of universal demand; the far greater number of the inhabitants eat only bread made from it from necessity, and those who can afford wheaten bread eat commonly that of rye from choice. At the tables of the first families, both in Germany and Poland,

though wheaten bread was always to be seen, Mr. Jacob remarked that the natives scarcely ever tasted it.

‘From the time,’ says this gentleman, ‘I left the Netherlands, through Saxony, Prussia, Poland, Austria, Bavaria, and Wurtemberg, till I entered France, I never saw, either in the bakers’ shops, in the hotels, or private houses, a loaf of wheaten bread. In every large town, small rolls, made of wheaten flour, could be purchased, and they were to be seen at the tables at which foreigners were seated. In the small towns and villages only rye bread can be obtained; and travellers commonly take in their carriages sufficient wheaten rolls to supply them from one large town to the next. Wheat is only used by the natives for making what our English bakers would call fancy bread, or in pastry and confectionary.’

Although the increase of wheat is greater than that of rye, yet, as it absorbs all the manure of the farm, and requires the land to be ploughed twice more, it is now deemed to be the least profitable of the two crops by many of the farmers. As the rye receives the full benefit of the fallow, its increase is greater than that of the spring crops which follow it.

Barley and oats are sown in the spring which follows the harvesting the wheat and rye, and these complete the course, which is again followed by a whole year’s fallow. By this rotation of crops, the land bears corn only two years out of three; and the crop of the last year scarcely produces three times the quantity of the seed that was sown.

‘Like others,’ says our able reporter, ‘I was prevailed upon to pay the closest attention to the details and face of the land of the most skilful, the most affluent, and most productive proprietors. I visited several noblemen, whose knowledge of and attention to agriculture was fully equal to that of any men in this or any other country; and, if the produce of the land was not equal to that raised by our best farmers, the difference must be attributed rather to the soil and climate than to any deficiency either of capital, of skill, or of assiduity. On such property the wheat sown was very insignificant, and the proportion of that grain to rye had gradually declined of late years. One nobleman, who farmed his estate of 26,000 acres, of which two-thirds was tillage, and one-third woodland, grew but a few acres of wheat, and of late had sold no corn of any kind. From the ports of England being shut against corn, he had turned his attention to the production of fine wool. On this estate there is a flock of 15,000 merino sheep, yielding on an average two pounds and a half of fine wool, the annual sales of which amount to one-half more than the value of the sheep. Through the five winter months the sheep are fed with corn, chiefly rye, at the rate of one pound per day, which is estimated to be equal to three pounds of hay. The proprietor calculated, that sheep thus kept yielded nearly as much more wool as, added to the benefit which the manure of the animals received from that kind of food, was equal to the price he should have received for the corn, if he had sold it; and

that the profit on this system was the value of the whole of the hay, which would have been otherwise consumed. Instead of selling, he finds it more profitable to buy corn. On the same property, the extent of land planted with potatoes was upwards of 1500 morgens, or about 1000 acres, the chief part of which were used in the distillery, which seems an indispensable adjunct to every well-managed farm. The calculation made there was that two bushels of potatoes yielded as much ardent spirit as one of barley; and that the residuum, after extracting the spirit, was equal in alimentary power, for the draft bullocks, which are fed with it, to two-thirds of its value before the wort was extracted from it. By the process on this estate nine bushels of potatoes are mixed with one of malt, to draw the wort, which is afterwards distilled, so as to produce a spirit containing eighty per cent. of alcohol, in which state it pays a duty, much complained of, of sixpence per gallon. It is reduced, before it is sold, till it retains fifty per cent. of alcohol; and the price charged to the retailers is about fourteen-pence per gallon.

‘Another person, of the same rank, who had turned his attention to the improvement of his property, boasted that his corn land already yielded nearly six fold for the seed that was sown, and could be further increased. He, too, cultivated potatoes very extensively, and, by converting them into starch and treacle, made that land yield a profit which, had it been devoted to corn, would have produced a loss. He had tried to make sugar from potatoes, and found it not advantageous; but he assured me that treacle paid him well, and he could afford to sell it 18s. per cwt., whilst that from the West Indies cost 24s. I could perceive no difference between the sweetness of this treacle and that from the tropics, but it has less consistency. A nobleman whom I had before known, to whose hospitality I am much indebted, and whose estate I viewed in detail, took the trouble to furnish me with the course of cultivation he pursued on the property on which he resides. Though cultivated with care, and though fairly productive, I readily give credit to what he assured me,—that the whole benefit which he derived from the estate of 6300 acres, in his joint capacity of landlord and cultivator, had not exceeded the amount for which he had sold the annual clip of the wool of his flock of 4000 sheep.

‘On the several other estates that I viewed, the recurrence of corn crops was equally distant; the superior portion of land devoted to green crops, and pasture, the same; and the stock of cattle bore nearly a like proportion. These, however, were exceptions, few in number and confined in extent, when compared with the general condition of the estates of the three provinces.’

The new proprietors, he afterwards states, who have been raised to that condition by the abolition of the ancient feudal tenures, though they can scarcely ever want the bare necessities of life, have very little beyond them. If they happen to be both industrious and economical, their own labor, on the small portion of land which they possess, will supply them with potatoes and

some little bread corn, as well as provision for their two oxen. They all grow a small patch of flax, and some contrive to keep five or six sheep. If disposed to labor beyond the time required for their own land, there is a difficulty in obtaining employment; and in the winter months, which are long and severely cold, no agricultural work can be performed. The flax and the wool spun in their cottages must supply the clothing of the family; and the fat of the animals they kill must be converted into soap and candles. Meat of any kind can be rarely afforded to be eaten by such families; and only the few who are more prosperous than their neighbours can keep a cow to supply them with milk. They consume nearly all they produce, and are considered happy if they have a sufficient surplus for sale to meet the demands of a few shillings annually for the payment of their trifling taxes and local assessments. It was the universal opinion of all with whom I had any conversation on the topic that this description of peasants were hitherto in a worse condition than under the old tenures; and as this was attributed to the depression of agriculture, and the want of capital, and of incitement to the large occupiers to employ their spare time, it was not considered to be an impeachment of the wisdom which had planned and executed their emancipation.’

*Low state of agriculture.*—In general the soil of the maritime provinces of Prussia is so light that it may be easily ploughed with two oxen, and those of diminished size and no great strength. On the smaller portions of land a single cow is not unfrequently seen drawing the plough; the latter guided by the owner, while the cow is led by his wife. The more tenacious soils, on the banks of the streams, are commonly but of small extent. There is indeed a large portion of land on the Delta, formed by the separation of the Nogat from the Fistula, between Derschau and Marienburg, which, under a good system of management, would be highly productive, and which requires greater strength to plough. Some others, especially near Tilsit, are of less extent; but the whole of them, if compared with the great extent of the surface of the country, are merely sufficient to form exceptions to the general classification which may be made of the soil. The various implements of husbandry are quite of as low a description as the working cattle. The ploughs are ill constructed, with very little iron in them. The harrows are made of wood, without any iron, even for the tines or teeth. The waggons are mere planks, laid on the frame loose, and resting against upright stakes, fixed into its sides. The cattle are attached to these implements by ropes, without leather in any part of the harness. The use of the roller is scarcely known; and the clods, in preparing the fallow ground, are commonly broken to pieces by hand with wooden mallets. In sowing, the seed is carried in the apron, or the skirts of the frock of the man who scatters it on the ground.

The monied value of the live stock on the farms is low. The best flocks of Merino sheep, exclusive of the wool, are averaged to be worth about 6s. or 6s. 8d. per head. Cows are worth from 30s. to 65s. A dairy which Mr. Jacob saw,

of the best description, was let to a dairyman at 36s. per year. The owner told him he valued them at 75s. per head, and thought the average weight of the butter from each, the calf being taken from the mother when ten days old, was about 120 lbs. each year. The variation in the price of cows is much greater than in that of sheep, according to their race, to the soil on which they are pastured, and to the distance from large towns requiring supplies of milk and butter. The price of hay varies, according to the situation and quality, from 14s. to 20s. the ton.

*Taxes.*—The general burdens of the state in Prussia are the subject of complaints among all classes; and although they may appear to us to amount to a very small sum, rated by the number of persons, they must be considered heavy in a country so destitute of little other capital than that of land, now vastly depreciated in value. The whole taxes in Prussia amount to about 10s. per head; but the effective value of money, in exchange for commodities, may be considered to be double what it is with us.

The land is divided into six classes, the rent of the lowest of which is estimated to be about 7d. per acre, and that of the highest about 4s. an acre. On this amount the *grund steuer* or land tax is twenty-five per cent., and averages in the three maritime provinces somewhat less than 3d. per acre. The gross amount collected in the three provinces annually, according to Hassel, is about £265,000 sterling. The local taxes do not fall wholly on the land. That for the disabled soldiers, and the families of such as fell in the conflicts, is in part borne by the cities and towns, though the chief weight falls on the land. The same, in some measure, is the case respecting the tax for roads, bridges, schools, and the poor. These are various in different districts, so that it is impossible to form any general estimate of their amount. In some parts of the country they appear to be equal to the *grund steuer*; in others higher; and in others they do not amount to one-tenth. Among the cultivators there is much complaint of the heavy tax on the distilleries.

The *military service* is extremely onerous throughout Prussia, as every young man is compelled to serve three years, from the age of twenty to twenty-four, as a soldier. This, though not precisely a tax, and not peculiar to the agricultural class, is a burden which perhaps presses as much on the productive industry of the country as the heavier taxes that are collected in other countries. To this must be added the quartering of the troops, who are billeted on private houses; and, however well discipline may be maintained amongst them, must be a great annoyance, and in most cases an expense, which, though apparently trifling in amount, becomes weighty to those whose means of supporting it are small. In a country where four-fifths of the inhabitants subsist wholly by producing food, and depend for the conveniences besides bare food on the price which they can obtain for their surplus, the low rate at which that surplus can be disposed of must be felt and observed in every rank of society.

The *scale of living* in the country we are con-

sidering corresponds with the low prices of the objects in which their labor is employed. The working class of the inhabitants, amounting in the maritime provinces to upwards of 1,000,000, including both those who work for daily wages and those who cultivate their own little portions of land, cannot be compared to any class of persons in England. This large description of the inhabitants live in dwellings provided with few conveniences, on the lowest and coarsest food; potatoes, or rye, or buck wheat, are their chief, and frequently their only food; linen, with flax of their own growth, and wool, spun by their own hands, both coarse and both worn as long as they will hold together, furnish their dress; whilst an earthen pot that will bear fire forms one of the most valuable articles of their furniture. As fuel is abundant they are warmed more by close stoves than by the shelter of their wooden or mud houses covered by shingles, which admit the piercing cold of the severe weather through abundant crevices. If they have bees and a plot of chicory, their produce serves as a substitute for sugar and coffee; but too often these must be sent to market to raise the scanty pittance which the tax-gatherer demands. Though the price of whiskey is low, yet the farm produce is still lower; and neither that, nor the bad beer which is commonly brewed, can be afforded by the peasantry as a usual drink. In common seasons this description of people suffer much in the winter; but in times of scarcity, such as followed the disastrous harvest of 1816, their distress and their consequent mortality is increased.

Since the acquisition of the Rhenish provinces, wine is one of the most important of the Prussian products. They yield various kinds of a good quality; and the average quantity is estimated at 100,000 hogsheads.

The Prussian horses differ little from those of the adjacent districts, but are generally considered as inferior to the Polish: for the Prussian cavalry are chiefly supplied from that country. The domestic cattle are likewise the same as in the other parts of Northern Germany. Silesia, Saxony, and the provinces near the Rhine, are the best adapted for supporting a superior breed of sheep; and the increase of Merinos has greatly augmented both the quantity and quality of the wool yielded by these districts. M. Krug has lately given the following estimate of the live stock in the entire Prussian States; viz.—

Horses . . . .	1,661,800
Cattle . . . .	5,252,820
Sheep and Lambs . .	11,230,000
Swine . . . .	2,640,000
Goats . . . .	181,000
Asses and Mules . .	9,680
Bee-hives . . . .	521,000

The *minerals* of Prussia are found chiefly in the high ground of the Westphalian and Rhenish provinces, particularly in the mountainous district of the Harz. Iron, copper, lead, vitriol, alum, saltpetre, are all found here, and, in a smaller degree, silver. Salt from brine springs, and coal, are abundant in some parts of Prussian

Saxony; but the expense of conveyance prevents the use of the latter for fuel. Amber is found in several parts of Prussia Proper. The whole annual value of mineral produce in the states is about £2,000,000.

*Timber* can be exported only from the vicinity of rivers or canals. Hops, in like manner, are confined to particular districts. Westphalia has long been noted for its hams; Pomerania for its poultry. Game is abundant in many parts. The fisheries are confined to the shores of the Baltic, the lakes, and the mouths of the great rivers. The general use of coffee, and the notion that the import of large quantities of it from abroad was a disadvantage, induced certain individuals, so far back as the year 1780, to attempt to find a substitute for it. Several plants were tried; among which the root of succory was most successful, and is now cultivated to a great extent to mix with coffee.

Weaving is the general employment of the lower orders in Silesia and Westphalia, long noted for their linens, also in no small degree, in Pomerania. Woollens are made, more or less, in almost every town or large village: in some parts of Silesia, and of the province of the Lower Rhine, they are manufactured in great quantities. Cotton manufactures are of recent introduction, and are found chiefly near the Rhine, at Berlin, at Erfurt, at Elberfeld, and in particular quarters of Silesia. These and hardware are the only fabrics carried on in collective establishments; the Prussian linens and woollens being both made by individuals in their cottages. Next in importance is the leather manufacture, then earthenware, glass, paper, tobacco, starch, potash, and vitriol. Brewing is also a pursuit of considerable importance.

Possessing on the Baltic the ports of Dantzic, Königsberg, Memel, and Stralsund, the commerce of Prussia has kept fully pace with her interior cultivation; and the maintenance of neutrality during so many years of war between Britain and France (from 1795 to 1806) was highly favorable to it. Subsequently, however, it suffered greatly, particularly in 1810, 1811, 1812, and has recovered but slowly. The last century was in Prussia the era of monopolies: one company had the exclusive right of manufacturing and selling tobacco; another were the sole importers of salt; while a third had a contract to supply Potsdam with firewood. Another abuse, remedied only since 1818, was the tax levied on the introduction of merchandise from one province of the kingdom to another. A third, and one not within the control of the government, is the heavy transit duty levied by the Dutch and Hanoverian governments on foreign goods imported by the Rhine, on the Ems and the Weser. The result is, that the commerce of Prussia, though conducted under many advantages, both maritime and inland, is in an early stage. The value of goods annually exported differs under different circumstances, but the great article of linen is steady in amount. The whole may probably be averaged between £7,000,000 and £8,000,000 sterling, or about a seventh of the exports of England. They consist, in addition to linen, of woollens and hard-

ware, corn, wool, timber, pitch, tar, potash, lintseed, tobacco, wax; horses, horned cattle, hogs, salt meat, and, from a few maritime towns, the produce of the fisheries. Distilled spirits are also, like corn, an article of export from the eastern part of the kingdom. The imports comprise coffee, cotton, sugar, tea, and other produce of the colonies; the wines, silk, fruit, and bay-salt of the south of Europe, printed cotton, and the finer hardware, tin, furs, and dye-stuffs. The chief trade takes place with Great Britain, whither Prussia sends her corn, and takes in return manufactures and colonial goods.

The *religion* of the royal family, and of the majority of the population of Prussia, is the Calvinist; but Christians of all denominations are admitted, on an equal footing, to public employments. The year 1817, the 300th anniversary of the reformation, was remarkable for the union of the Calvinists and Lutherans of the Prussian dominions, and of some other parts of Germany, into one religious community, under the name of Evangelical Christians. The relative number of the different creeds is thus stated,

Calvinists and Lutherans	6,600,000
Catholics	3,600,000
Jews	75,000
Baptists	14,000
Moravian brethren	7,000
Unitarians, Pietists, and members of the Greek church	4,000

The elementary *schools* in Brandenburg, Saxony, and part of Prussia Proper, are numerous, and well conducted. Silesia has also much improved in the means of education since the middle of last century; but in other parts of the kingdom, particularly where the majority are Catholics, the government has as yet been unable to introduce much reform. The universities are those of Berlin, Halle, Breslau, Königsberg; and here, and at Dantzic, Magdeburg, and a number of other towns, are academies (under the name of gymnasia, colleges, or high schools), in which are taught the classics and mathematics, the modern languages, drawing, &c. There are also, in the large towns, schools of surgery and midwifery distinct from the universities; but for the study of medicine, in a comprehensive sense, Vienna is the great resort of all Germany. Frederick II. established an academy of sciences at Berlin, and associations of a similar nature, but on a smaller scale, are established in most of the great towns.

Frederick II. also introduced the liberty of the press to that degree which led to the production of a number of books disfigured by declamation and extravagance. Others were, however, of a different character, and full of useful information. The result was the formation of that spirit of freedom which has for some time back caused great disquietude to the executive, and produced, in 1819, the restrictive enactments of the congress of Carlsbad. It is said that some of the best writers in the Prussian dominions have been Jews.

Several of the kings of Prussia have been economists. The father of Frederick II., with a revenue of only £1,200,000, found means to leave at



his death, in 1740, a well replenished treasury and a large army. His successor, notwithstanding expensive wars and improvements, left in 1785 a treasure of £7,000,000. This disappeared in the reign of his successor, and prior to the year 1785. In the twelve succeeding years of peace, the standing army was numerous and expensive, and the misfortunes of 1806, and the great exertions made in 1813, 1814, and 1815, have all borne so hard on the Prussian finances, as to have led to the creation of a debt amounting to above £45,000,000 sterling. After all her late acquisitions, the revenue of Prussia is not above £7 500,000: but there is no paper currency. Mr. Jacob, in his *View of Germany*, gives the following state of the revenue, and the proportions contributed by the different provinces of the monarchy, in 1819, viz.—

East Prussia . . . . .	8,100,000
West Prussia . . . . .	3,750,000
Posen . . . . .	3,100,000
Brandenburg . . . . .	9,000,000
Pomerania . . . . .	3,000,000
Silesia . . . . .	13,500,000
Saxony . . . . .	10,417,000
Westphalia . . . . .	8,431,000
Juliers, Cleves, and Berg . . . . .	8,670,000
Lower Rhine . . . . .	7,000,000

Guldens, or 74,968,000

Sterling £7,528,003

The Prussian army was a subject of admiration to all foreigners, during great part of the eighteenth century. On the termination of his dreadful struggle, in 1763, Frederick II. determined to cultivate peace, and to trust to the gradual operation of time for the reinstatement of his finances and army. Such, with little deviation, was the policy of Prussia during forty years; and the number of disciplined men belonging to the army during this period was carried to more than 200,000, without involving a permanent expense of more than half the number. The battle of Jena was followed by the surrender of successive corps and garrisons, to the number of more than 100,000; and the loss of the financial resources of the kingdom reduced for a time the Prussian military establishment to utter insignificance. The humiliating peace of Tilsit restricted the means of its reinstatement; but, in 1813, the national ardor burst forth, and the old soldiers repaired to their standards, in a manner that excited universal admiration. They soon asserted in Silesia, their superiority over the raw levies of the French, and maintained their character in a more advanced stage of operations in Saxony and Champagne. At Ligny, in 1815, the army was 80,000 strong: the total number of Prussian troops under arms that year exceeded 200,000. Since then, the confirmation of peace, the complaint of heavy taxation, and the reductions of neighbouring powers, have led to a partial diminution of the military establishment; but it still exceeds 150,000. At Berlin, Breslau, Königsberg, and at Stolpe in Pomerania are military schools: where every branch of the service, whether

cavalry, artillery, or infantry, is diligently attended to.

Prussia had formerly a representative body, under the name of states. While the powers and privileges of the nobility were also very extensive, comprising, until lately, the local administration of justice. By degrees, the power of the crown reduced that of the aristocracy; and the sovereign found means to conduct the public business independent of the states. Such was the state of political affairs during the eighteenth century. But the diffusion of knowledge awakened the attention of the middling ranks to the existence of a number of abuses, and to the necessity of electing a representative body: this feeling and hope prompted the memorable exertions in 1813, 1814, and 1815, for the overthrow of Buonaparte; and great disappointment has been experienced by the better classes of society at the successive delays and evasions of the court, which as yet has done little more than new model the executive departments. Each circle or district has its council for the transaction of public business, viz the collection of the direct taxes, regulation of local traffic, and superintendance of police. In the second place, each government has an administrative board, charged with a similar superintendance; while, at the head of each of the ten provinces, is a high president, who, like the *préfet* of a French department, serves as a medium or connecting link between the province and the ministers. These are nearly on the same footing as in England and France. The orders of knighthood are four. The noblesse or gentry, comprising 20,000 families, were formerly exempt from part of the taxes, and considered as entitled to a preference in public appointments; but the disasters of 1806 taught government the folly of these preferences, and led also to the abolition of exclusive privileges in regard to trades, &c.

The first proceedings of the law take place before justices, or courts of limited jurisdiction, nominated chiefly by the king, but in certain districts by the mediatised princes, or ecclesiastical dignitaries of the quarter; the second stage of jurisdiction is the *Oberlandes gerichte*, or courts in each government; and the final appeal is to the supreme courts at Berlin, consisting of a high tribunal and commission. Ecclesiastical affairs are managed by provincial consistories or commissions: and medical police is, in like manner, subject to a provincial commission. Commercial affairs are superintended by a board of merchants in several of the towns, particularly at Berlin, Königsberg, and Swinemunde. The highest court for fiscal questions is the *exchequer*, or high chamber of reckoning at Berlin.

The Prussians are generally allowed to be a brave and industrious people. They have more military parade, more show, and higher pretensions, than any other people of northern Germany. Berlin is considered as the Paris of that part of the continent; but, in other parts of old Prussia, the people have a tinge of gloom in their character. Some writers have ascribed this feature to the nature of their government, the strict and unceasing vigilance of which, and the constant and uniform obedience of the people,

have, doubtless, done much towards superinducing such a disposition in the inhabitants.

**HISTORY.**—On the expulsion of the Christians from the Holy Land, by Saladin, a settlement was given to the Teutonic knights in Prussia by Conrade duke of Masovia, the competitor of Boleslaus V. for the crown of Poland. Their first residence in this country was Culm; to which territory they were confined by the conditions of the donation, excepting what they could conquer from their pagan neighbours, all of which the emperor granted to them in perpetuity. Encouraged by this grant, the knights conquered the greatest part of the country which now goes by the name of Prussia; and became very troublesome to POLAND: see that article. The Teutonic order continued in Prussia till 1531. Their last grand-master was Albert marquis of Brandenburg, nephew to Sigismund I., king of Poland. He was preferred to this dignity in hopes that his affinity to Sigismund might procure a restitution of some of the places which had been taken from the order during the former unsuccessful wars with Poland; but Albert, instead of endeavouring to obtain any favor from his uncle, refused to do homage to him, began to assert his independence, and to recover the whole of Prussia and Pomerania by force of arms. But, being foiled in every attempt, he was forced to resign the grand-mastership, instead of which his uncle gave him Ducal Prussia. It was now the interest of the house of Brandenburg to assist in the expulsion of the fraternity; and accordingly, being at last driven out of Prussia and Pomerania, they transferred their chapter to Mariendal in Franconia; but in that, and other provinces of the empire where they settled, little more than the name of the order once so famous now remains.

The other most considerable part of his Prussian majesty's dominions is the electorate of Brandenburg. Like other parts of Germany, it was anciently possessed by barbarians, of whom no history can be given. These were subdued by Charlemagne; but, being on every occasion ready to revolt, in 927 Henry the Fowler established margraves, or governors of the frontiers. The first margrave of Brandenburg was Sigefroy, brother-in-law to Henry, under whose administration the bishoprics of Brandenburg and Havelberg were established by Otho I. From this Sigefroy, to the succession of the house of Hohenzollern, from whom the present elector is descended, there are reckoned eight different families, who have been margraves of Brandenburg; namely, the family of the Saxons, of Walbeck, Staden, Plenck, Anhalt, Bavaria, Luxemburg, and Misnia. The margraves of the four first races had continual wars with the Vandals and other barbarous people; nor could their ravages be stopped till the reign of Albert, surnamed the Bear, the first prince of the house of Anhalt. He was made margrave by the emperor Conrad III., and afterwards elector by Frederick Barbarossa, about A. D. 1100. Afterwards the king of the Vandals dying, without issue, left the Middle Marche to the elector, who was possessed of the old Marche, Upper Saxony, the country of Anhalt, and part of Lusace. In 1332 this line

became extinct, and the electorate devolved to the empire. It was then given by the emperor Lewis of Bavaria to his son Lewis, who was the first of the sixth race. Lewis the Roman succeeded his brother; and, as he also died without children, he was succeeded by Otho, his third brother, who sold the electorate to the emperor Charles IV. for 200,000 florins of gold. Charles IV. gave the Marche to his son Wenceslaus, to whom Sigismund succeeded. This elector, being embarrassed in his circumstances, sold the new Marche to the knights of the Teutonic order. Josse succeeded Sigismund; but, aspiring to the empire, sold the electorate to William duke of Misnia; who, next year sold it again to the emperor Sigismund. In 1417 Frederick VI., of Nuremberg, received the investiture of Brandenburg at Constance from the emperor Sigismund; who, in 1415, had made him elector, and arch-chamberlain of the empire.

This prince, the first of the family of Hohenzollern, found himself possessed of the Old and Middle Marches, but the dukes of Pomerania had usurped the Marche Ukraine. Against them, therefore, the elector immediately declared war, and soon recovered the province. As the New Marche still continued in the hands of the Teutonic knights, the elector took possession of Saxony, then vacant by the death of Albert the last elector of the Anhalt line. But the emperor gave the investiture of Saxony to the duke of Misnia; upon which Frederick voluntarily resigned his acquisitions. This elector made a division of his possessions by will. His eldest son, because he had attempted to search for the philosopher's stone, was left only Vogtland. The electorate was given to his second son Frederick; Albert, surnamed Achilles, had Franconia; and Frederick the fat had the old Marche; but by his death it returned to the electorate. Frederick I. was succeeded by his son Frederick, surnamed Iron-tooth. He might have been surnamed the Magnanimous, for he refused two crowns, viz. that of Bohemia, offered him by the pope, and that of Poland by the people; but Frederick declared he would not accept of it unless Casimir, brother to Ladislaus the late king, refused it. This induced the states of Lower Lusatia to make a voluntary surrender of their country to him. But, Lusatia being a fief of Bohemia, the king of that country made war on the elector to recover it. But by a treaty, in 1462, he was obliged to yield the sovereignty of Corbus, Peits, Sommerfeld, &c. Frederick then, having redeemed the New Marche from the Teutonic order for 100,000 florins, and still further enlarged his dominions, resigned the sovereignty in 1469, to his brother Albert, surnamed Achilles. Albert was at this time fifty-seven years old. Most of the exploits, for which he had the surname of Achilles, had been performed while he was burgrave of Nuremberg. He had defeated and taken prisoner Lewis duke of Bavaria. He had gained eight battles against the Nurembergers, in one of which he fought singly against sixteen men. He had taken Greissenburg, as Alexander took the capital of the Oxydrace, and Frederick III. gave him the direction of almost the whole empire. He had also gained the prize at seventeen tourna-

ments. From this period nothing important occurred till 1594, when, John Sigismund of Brandenburg, having married Anne the only daughter of Albert duke of Prussia, that duchy was joined to the electorate, with which it has continued united ever since; and gave pretensions to the countries of Juliers, Berg, Cleves, Marck, Ravensburg, and Ravenstein, to the succession of which Anne was heirless.

Sigismund died in 1619, and was succeeded by his son George William; during whose government the electorate suffered the most miserable calamities. At this time a war commenced between the Protestants and Catholics, which lasted thirty years. The former, although leagued together, were on the point of being utterly destroyed by the Imperialists under Tilly and Wallenstein; when Gustavus Adolphus turned the scale in their favor, and threatened the Catholic party with utter destruction. But by his death, at the battle of Lutzen, the fortune of war was once more changed. At last, however, peace was concluded; and, in 1640, the elector died, and was succeeded by his son Frederick William. This young prince, though only twenty years of age at his succession, applied himself to repair the losses and devastations occasioned by the dreadful wars which had preceded. He received the investiture of Prussia personally from the king of Poland, on condition of paying 100,000 florins annually, and not making truce or peace with the enemies of that crown. His envoy likewise received the investiture of the electorate from Ferdinand III. The elector now concluded a truce for twenty years with the Swedes, who evacuated the greatest part of his estates, concluded a treaty with the Hessians, who delivered up a part of the duchy of Cleves; and obtained of the Hollanders the evacuation of other cities. In the mean time the powers of Europe began to be weary of a war which had continued for so long a time with such unrelenting fury. The conferences were opened at Osnaburg and Munster, in 1645. France demanded that Pomerania should be ceded to Sweden, as an indemnification for the expenses which the war had cost Gustavus Adolphus; but, though the empire and the elector refused to give up Pomerania, it was at last agreed to give up to the Swedes Hither Pomerania, with the isles of Rugen and Wollin, and some other cities; in return for which, the bishoprics of Halberstadt, Minden, and Camin, were secularised in favor of the elector, and ceded to him, with the lordships of Hohenstein and Richenstein, and the reversion of the archbishopric of Magdeburg. Thus was the treaty of Westphalia concluded in 1648, which so long served as a basis for all the possessions and rights of the German princes. The elector then concluded a new treaty with the Swedes, for the regulation of limits, and for the acquittal of some debts; and next year the electorate, Pomerania, and the duchy of Cleves, were evacuated by the Swedes. Notwithstanding these treaties, however, the Swedes soon after invaded Pomerania, but were entirely defeated by the elector near Fehrbellin; with the loss of 3000 killed, and many prisoners. He pursued his victory, gained many advantages over the

Swedes, and took the cities of Stralsund and Gripswald. On this the Swedes, to oblige the elector to evacuate Pomerania, which he had almost totally subdued, invaded Prussia, from Livonia, with 16,000 men; burnt the suburbs of Memel, and took Tilse and Insterburg. The elector, to oppose the invaders, left Berlin on the 10th of January, 1679, at the head of 9000 men. The Swedes retired at his approach, and were very much harassed by his troops. So successful indeed was Frederick on this occasion, that the Swedes lost almost one-half of their army. At last, having crossed the bay of Frischehoff and Courland on the ice, he arrived on the 19th of January, with his infantry, within three miles of Tilse, the head quarters of the Swedes. The same day his general, Trefenfeldt, defeated two Swedish regiments near Splitter; and the Swedes abandoned Tilse. They were pursued into Courland by general Gortz, and defeated with such slaughter that scarce 3000 of them returned to Livonia. Yet, notwithstanding these victories, the elector, pressed by the victorious generals of France, Turenne and Conde, was obliged to make peace with the Swedes. The conditions were, that the treaty of Westphalia should serve for a basis; that the elector should have the property of the customs in all the ports of Further Pomerania, with the cities of Camin, Gortz, Griessenburg, and Wildenbruck; while he gave up to the Swedes all that he had conquered from them. Frederick William passed his last years in peace. His great qualities had rendered him respected by all Europe, and had even reached Tartary, whence he received an embassy courting his friendship. From 1684 to 1686 he received into his dominions 20,000 Protestants who fled out of France, after the revocation of the edict of Nantz, and who introduced new arts and manufactures, that were of the utmost benefit to the country. By this, however, he disobligeed Louis XIV., for which reason he concluded an alliance with the emperor; and, having furnished him with 8000 troops against the Turks in Hungary, the emperor ceded to him the circle of Schwibus in Silesia. In 1688 the elector Frederick William died, and was succeeded by his son Frederick III.

This elector was remarkably fond of show and ceremony; and the great object of his ambition seemed to be the regal dignity. To obtain this, he joined with the emperor in the alliance against France in which he was engaged by our William III. He also yielded up the circle of Schwibus, which had been given to his predecessor; and, in 1700, obtained from the emperor that dignity which he had so earnestly desired. The chief terms on which it was obtained were, that he should never separate from the empire those provinces of his dominions which depended on it; that he should not, in the emperor's presence, demand any other marks of honor than those which he had hitherto enjoyed; and that he should maintain 6000 men in Italy at his own expense, in case the emperor should be obliged to make war on account of the house of Bourbon's claim to the crown of Spain. Frederick I. continued all his life in strict alliance with the emperor

Frederick I. died in the beginning of 1713, and was succeeded by Frederick William I., in almost every thing the reverse of his father. His dispositions were altogether martial; so that he applied himself entirely to the augmentation of the army. His whim was to have it composed of men above the ordinary size, and his officers made no scruple of picking up such men wherever they could find them. However he was never engaged in any martial enterprise of consequence; but having put his army on the most respectable footing, and filled his coffers, he put it in the power of his son to perform those exploits which astonished all Europe. Frequent bickerings took place between the prince and the emperor, for which the persecution of the Protestants by some of the Catholic states of the empire afforded a pretence. But when Frederick William died, in 1740, this enmity broke out in full force.

Frederick II., immediately on his accession, seized upon Silesia, of which his ancestors, he said, had been unjustly deprived. But it cost him dear; for the empress queen, having overcome her momentary difficulties, formed against him the most formidable combination that had hitherto been known in Europe. The treaty was hardly concluded, by which she reluctantly yielded up Silesia, with a revenue of £800,000 a year, before she entered into another with Russia. This treaty, called the treaty of Petersburg, was apparently only defensive; but six secret articles were appended, one of which was, that if the king of Prussia should attack the empress queen, or Russia, or Poland, it should be held as a breach of the treaty of Dresden: another contained a plan for a partition of Prussia. The empress queen concluded also a treaty with France, on the 1st of May, 1756. Frederick, hearing of these machinations, resolved to be before-hand with his enemies, and, entering Saxony with a considerable army, demanded a free passage for his troops, on the principle of the king of Poland's professed neutrality; which being refused, he blockaded the Saxon camp at Pirna. To oppose the two Saxon armies, then in Bohemia, he placed one army under M. Schwerin and another under the celebrated M. Keith; and soon after joined the latter: on the first of December, 1756, he attacked and defeated the Austrian general. On this the king of Poland quitted his German dominions, and the Prussians took up their quarters in Saxony, where they seized the revenues and raised recruits: in the archives of Dresden Frederick discovered the originals of the secret articles above-mentioned. Mean time he was put to the ban of the empire; the circles were ordered to furnish their contingents: the French sent a large body of troops under prince de Soubise; the Austrians raised 100,000 men under prince Charles of Lorraine and M. Brown; and the Czarina sent 60,000 under M. Apraxin into Ducal Prussia, with a strong fleet to co-operate with them in the Baltic. The king of Sweden and the duke of Mecklenburgh also joined the combination; while Prussia had not a single ally, except about 35,000 Hanoverians under the duke of Cumberland; who were soon forced to yield to a superior army

of the French. In spring 1757 the Prussians entered Bohemia in three divisions; one under the king; another under general Schwerin; and the third under the prince of Bevern, from Lusatia, where he defeated an army of 28,000 Austrians. The Austrians then detached another body of 20,000 men from their main army; whereupon Frederick cut off all communication between that detachment and the main body, and, having quickly joined his two generals, attacked the Austrians near Prague and totally defeated them, but lost the brave general Schwerin. The Austrian general, also, was mortally wounded; and about 40,000 of his troops took refuge in Prague, which was immediately invested by the king. The garrison made a sally, but were repulsed, as were also 12,000 of the inhabitants, who wished to quit it. In this desperate situation, Leopold count Daun took the command of the remains of Brown's army, and having collected 60,000 of them retired to a strong post near the town. Frederick sent against them only 32,000 men, who were defeated at Colin on the 18th of June, after a bloody battle. The king then raised the siege of Prague, left Bohemia, and retired into Saxony.

Meantime the Russians, under Apraxin and Pormor, were committing the greatest cruelties in Ducal Prussia. The Austrians entered Silesia, penetrated to Breslau, and besieged Schweidnitz. Another body of them took Zittau. An army of 22,000 Swedes also entered Prussian Pomerania, took Anclam and Demmein, and plundered the country: while the French devastated Halberstadt and the Old Marche of Brandenburg. General Haddick laid Berlin itself under contribution. The Prussian general, Lehwald, with 30,000 men, attacked 30,000 Russians, who were strongly entrenched at Norkitten, but, though they performed prodigies of valor, were obliged to retire. At last, on the 5th of November 1757, the king of Prussia met, at Rasbach, with the united army of his enemies under prince Saxe-Hilburghausen and general Soubise, amounting to 50,000 men. His army did not amount to above half that number of men, but inspired with the most enthusiastic patriotism, and encouraged by the presence of their king, they completely defeated the Austrians, with the loss of 3000 men killed; eight generals, 250 officers, and 6000 men, prisoners, while night alone prevented their total destruction. But in Silesia the Austrians, after a siege of sixteen days, reduced Schweidnitz, and took the Prussian garrison of 4000 men prisoners. They next attacked the army under the prince of Bevern, encamped at Breslau, on the 22d of November; but were repulsed with dreadful slaughter. Yet the Prussians, soon after, rashly deserted their strong post, and in two days the prince of Bevern, reconnoitering carelessly, was taken prisoner; Breslau of course surrendered, and all was going to wreck, when the king, by a rapid march, passing through Thuringia, Misnia, and Lusatia, entered Silesia on the 2d of December, and was joined by the prince of Bevern's corps and the garrison of Schweidnitz. He now approached Breslau, where the Austrians, trusting to their numbers (amounting to 70,000) while the Prus-

sians were scarcely 36,000 men, left their strong camp and advanced to battle. The two armies met on the 5th of December near Luthen. Count Daun occupied a plain with some small eminences, and caused his troops to scatter a great number of trees in the road of the Prussians. But Frederick overcame all these difficulties: attacked the enemy with the utmost impetuosity, took the post, and a total rout ensued, wherein the Austrians lost 6000 killed, 15,000 prisoners, and 200 cannons. The consequences were great; Breslau surrendered on the 29th of December with a garrison of 13,000 men: the Russians retreated out of Ducal Prussia: general Lehwald expelled the Swedes out of Prussian Pomerania, and took part of Swedish Pomerania; and the king took ample vengeance on Mecklenburg. To add to his good fortune, the French were now so successfully opposed by the Hanoverians, under prince Ferdinand, that he had no more trouble from them.

On the 3d of April, 1758, Frederick laid siege to Schweidnitz, which surrendered on the 16th. He then disposed his forces in the best manner for the defence of his dominions, placing one army under count Dohna on the side of Pomerania; another between Wohlan and Glogau, to cover Silesia; and a third in Saxony under his brother prince Henry, consisting of thirty battalions and forty-five squadrons, to make head against the empire. All these armies were connected by posts. Frederick next, making a feint of invading Bohemia, suddenly burst into Moravia, over-run the whole country, and laid siege to Olmutz on the 27th of May. But general Daun, seizing a strong hold where he could not be attacked, obliged the king to raise the siege; which he did very unexpectedly, on the 1st of July, and marched in two columns into Bohemia. After laying Königgratz and the adjacent districts under contribution, he marched rapidly against the Russians, who had been employed in besieging Custrin, since the 15th of August. Frederick arrived on the 25th within sight of the Russians, after fifty-six days march: when they raised the siege and retired to Zorndorff. The battle of Zorndorff began at 9 A. M., and continued till 7 P. M., with various success and dreadful slaughter. At one period the Prussians had given way and fled before an army half defeated; but the king, by a rapid and masterly movement, brought his cavalry to the centre, and, falling on the Russian foot, put them into such confusion that they fired on each other, plundered their own baggage, and got so much intoxicated that the fire of the Prussians had dreadful effect. In a word, their loss, besides a vast train of artillery, amounted to 21,529 men, the military chest, &c., while that of the Prussians did not exceed 2000. The remains of the Russian army retreated to Landsperg; and the king marched to the relief of prince Henry. Here he met with a severe check. Marshal Daun had his camp advantageously situated at Stolpen, while the right wing of the king extended to Hochkirchen, by which he had a communication with prince Henry and protected Brandenburg. In this critical situation Daun surprised the Prussian camp at 5 A. M. on the 14th of Octo-

ber. The brave marshal Keith, and prince Francis of Brunswick, were killed on the spot; and though the king did his utmost to encourage his troops, and the victory was long doubtful, the king at last ordered a retreat, which he conducted in good order: but this bloody battle cost him 7000 men, with a great number of cannon. The Austrians lost 5000. Frederick next reinforced his army from that of prince Henry, and hastened to raise the siege of Neiss, which had been invested on the 4th of October. On the 24th he came to Gorlitz, where he defeated a party of Austrians, with the loss of 800 men; and soon after relieved Cosel. The king then hastened to the relief of Dresden, which was badly fortified and garrisoned by only 12,000 men. It had large suburbs, but these had been burnt by Schmettau, the governor, on the 10th of November, to prevent their being taken by the Austrians under Daun, as then all defence of the city would have been vain. Upon the king's approach all the Austrian armies retired into Bohemia. He now took up his winter quarters in Saxony, where he levied the most exorbitant contributions. On the 23d of February, 1759, general Wobersow marched with a body of Prussians into Poland, where he destroyed several large Russian magazines. The successes of prince Henry, in the interim, cleared Franconia of their enemies; but now the Russians once more approached. The king disgraced count Dohna, for not opposing them with sufficient zeal, and appointed general Wedel in his place; who, on the 23d of July, with an army of not quite 30,000 men, attacked 70,000 Russians most advantageously posted at Zulichau. The Prussians fought with their usual bravery, but were defeated with the loss of 4700 killed or taken, and 3000 wounded. The consequences were that the Russians took Crossen and Frankfort on the Oder; on which the king joined Wedel with a large body of troops, leaving the rest of his army in Saxony, under prince Henry. But as Daun had sent 12,000 horse and 8000 foot, under Laudohn, to assist the Russians, the king was unwilling to venture a battle. This, however, became unavoidable; he therefore, on the 12th of August, attacked the enemy in their strong entrenchments with a heavy cannonade, forced the entrenchments with great slaughter, and took seventy-two cannon. The Russians made a stand at Cunnersdorf, but were driven from it, and from post to post to the last redoubts. For above six hours the Prussians were wholly successful; and victory was completely in their power, if the king had not lost it by his impetuosity. General Saltikoff assembled the remains of the Russian army at an advantageous post where prudence and policy would have allowed them to remain. But, the king attempting to drive them from it, his fatigued troops were overpowered, and the Austrians, who had not been much engaged all day, assisting them, the fortune of the day was turned so completely that nothing but the night coming on saved the Prussians from total destruction. Their loss amounted to 20,000 men. After this defeat Frederick exerted himself to procure artillery from Berlin; he recalled general Kleist with

5000 men from Pomerania; detached 6000 from his own army to defend Saxony; and with the remainder put himself between the Russians and Great Glogan; thus obliging them to return to Poland, notwithstanding their victory. New misfortunes, however, attended the Prussian arms. General Finch, who had been sent with 12,000 Prussians to oppose Daun, having advanced too far, was surrounded and obliged to surrender. General Durceke, and another body of Prussians, were posted at the Elbe, opposite Meissen; but were suddenly attacked by the Austrians, and lost 3000 men.

The year 1760 began with very unfavorable auspices. Since October 1756 forty generals had been killed in the Prussian service, exclusive of those wounded or taken: and most of Frederick's veteran soldiers had fallen in battle, and their places were filled up by raw inexperienced troops. At this time Laudohn drew general Fouquet and a body of above 11,000 Prussians into a situation from which they could not escape; and on the 23rd of June attacked them at midnight, near Landshut, when, though they made a brave defence, 4000 were killed, 7000 taken, with fifty-eight cannon, and not above 300 escaped. The victory, however, cost the Austrians 12,000 men in killed and wounded. Laudohn immediately followed it up by the capture of Glatz. Thence he marched against Breslau, and invested it; but, the king of Prussia having laid siege to the town on the 13th of July, Daun appeared within three miles on the 19th, and on the 21st had supplied it with sixteen battalions, which obliged the king to raise the siege. Breslau was also bombarded by Laudohn, but the approach of prince Henry obliged him to retire on the 5th of August. Meantime the king advanced into Silesia with his usual rapidity. This, however, did not prevent the junction of the armies under Laudohn, Daun, and Lacy, which formed a line of encampments, extending no less than thirty miles. They now laid a plan to attack and surround the king's army in the night; but Frederick, having heard or suspected their intention, quitted his camp privately, and took an advantageous post on the road through which Laudohn was to pass. A thick fog in the morning hid the Prussians till Laudohn saw them with surprise regularly drawn up for battle. An obstinate conflict ensued, wherein Laudohn was completely defeated, with the loss of 10,000 killed, wounded, and prisoners; eighty-two cannon, and twenty-three colors. This victory compelled count Czernichew, who was advancing with 24,000 Russians to join Daun, to repossess the Oder; and soon after the king joined prince Henry at New Marche, and, attacking a corps under general Breck, took two battalions of Croats prisoners. About this time too general Hulsen defeated the imperial army in Saxony. But a body of 15,000 Austrians, under generals Lacy and Brentano, with the whole of the imperialists in Saxony, began their march in concert with the Russians towards Berlin. These armies amounted to 40,000 men. The Prussian generals Hulsen and Werner could not raise above 16,000. Berlin was therefore abandoned to its fate; which, by the powerful mediation of several

foreign ministers, was better than could have been expected. The city, however, was obliged to pay the sums of 800,000 guilders, and 1,900,000 crowns: the magazines, arsenals, and foundries were destroyed; all the military stores, cannon, and other arms seized, and the king's palace plundered. The combined armies left Berlin in four days, dreading the vengeance of Frederick; and on their return took Leipsic, Torgau, Meissen, and Wirtemberg. A detachment of French under M. Stainville laid Halberstadt under contribution. In East Pomerania the Russians besieged Colberg; in West Pomerania the Swedes advanced, while Laudohn besieged Cosel; and Daun watched the king with a superior army. The Prussians did not amount to 50,000: the Austrians exceeded 86,000. The king therefore resolved to make a desperate effort. On the 3rd of November, 1760, he divided his forces into three columns, with one of which general Hulsen took post in a wood. With the other two columns, under himself and general Ziethen, the king attacked general Daun about 2 P. M., who received him with the fire of 200 cannon. The Prussians were thrice led on to the attack, but as often repulsed with dreadful slaughter; till, at length, general Zeithen with the right wing attacked the enemy in the rear, repulsed them, and got possession of some eminences. Encouraged by this success, the Prussians advanced, mastered the Austrian entrenchments, and made way for their cavalry, which broke in with irresistible fury and threw the Austrians into irreparable confusion. It was now about 9 P. M., both armies were in darkness, yet the firing continued, till M. Daun was wounded; and the command devolved on count O'Donnel, who ordered a retreat. This important victory cost the Prussians 10,000 killed and wounded, and 3000 prisoners. The loss of the Austrians in killed and wounded is unknown; but 8000 were taken prisoners, among whom were four generals and 212 other officers. The consequences of this victory were that the king recovered all Saxony, except Dresden; the Russians raised the siege of Colberg, and retired into Poland; Werner defeated the Swedes, and drove them totally out of West Pomerania; Laudohn raised the blockade of Cosel, and retired into Austrian Silesia; Daun placed his army in Dresden, and other strong posts south and west of it; and the imperial army retired into Franconia. But, though these successes retrieved the king's affairs, they exhausted his strength; and in 1761 he was unable to make any vigorous efforts. He continued strongly encamped at Schweidnitz, but was closely watched by Daun and Laudohn. He however defeated the designs of the Russians against Breslau, by sending general Platen to destroy their magazines, who at the same time cut off 4000 of their troops. But they retook Colberg on the 3rd of December; and, the king having drawn 4000 men out of Schweidnitz, Laudohn took it by a coup de main. In the midst of these adverse circumstances, the empress Elizabeth, Frederick's inveterate enemy, died on the 2d of January 1762, and was succeeded by Peter III. his warm friend. The consequences were a suspen-

sion of hostilities on the 16th of March, and a treaty of peace and alliance on the 5th of May. Sweden made peace too on the 22d of May. The arms of Prussia were now attended every where with success. Prince Henry drove the imperialists from several important posts in Saxony, which secured all the Prussian possessions there. The king was joined by the Russians in the end of June; after which he drove M. Daun to the extremity of Silesia. He then penetrated deep into Bohemia, where the Russians committed the same cruelties on their late allies, the Austrians, that they had long practised on the Prussians. But the deposition and murder of Peter III. occasioned a new change. Catharine II. was prejudiced against Frederick; but his private letters to Peter, wherein he had advised him to treat her well, being discovered, excited her gratitude; and, though she ordered her troops home, she adhered to the peace, and restored all the places taken during the war. The success of Frederick, however, continued: he totally defeated Laudohn; retook Schweidnitz, with a garrison of 8000 men; and, on the 29th of October, entirely routed the Austrians at Freyberg, vast numbers being killed, and 6000 taken prisoners. This decisive victory produced the peace of Hubertsburg, whereby every thing was settled in statu quo. After this Frederick turned his attention to the arts of peace; which was hardly interrupted in 1778 by a difference with Austria, about Bavaria. No other remarkable events occurred during his life, but what are already mentioned in our article *FREDERICK*. He died August 17th, 1786, and was succeeded by his nephew, Frederick William II.

Frederick the Great had bequeathed the most effectual securities to his successor for the preservation of his dominions, that human wisdom could provide or devise; and the new monarch, with these advantages, was not wanting to himself. But his uncle's predilection for the French language and French literature was not grateful to his subjects. Frederick-William began his reign with declaring in council, Germans we are, and Germans I mean we shall continue; giving directions at the same time, that their native language should resume its natural rank and station. This was a very popular measure, and it was followed by another still more so. Observing that he had marked with great concern the progress of impiety and profaneness on the one hand, and of enthusiasm on the other, he declared, that he would not have his subjects corrupted either by fanatics or atheists, and strictly prohibited all publications tending to excite a contempt or indifference for religion. An opportunity soon occurred, in which he was also thought to have displayed such talents in negotiation and in military arrangements, as proclaimed him in every respect a worthy successor of his uncle. The States of Holland, who had long been jealous of the power of the Stadtholder, and inclined to a republican government without any permanent chief, had gained such ascendancy in the states general, that in 1786 and 1787 they divested the prince of Orange of all his prerogatives. They proceeded even to the seizure and imprisonment of the princess, sister to the king of Prussia; and, de-

pending upon support from France, treated with insolence every power connected with them in Europe. The court of Berlin did not witness these proceedings without indignation; and the king formed his plan for restoring the power of the Stadtholder with such secrecy and prudence, that, in the space of one month, the duke of Brunswick led 18,000 Prussians to Amsterdam. The monarch's subsequent conduct was not such as the beginning of his reign gave reason to expect. See the article *POLAND*. He was, on the whole, a weak voluptuous character, who dissipated his treasures, and, in the part which he took against the French republic, by no means added to the reputation of the Prussian arms.

Frederick William III. came to the crown in 1797, and acted for several years in concurrence with France. In 1806, however, his eyes were opened to the usurpations of Buonaparte; war was determined on, and the army led to the western frontier, with as much confidence as if the French troops had been those of Louis XV. The result was the fatal battle of Jena; and the capture, in succession, of almost every corps of the Prussian army; the loss of Berlin, and soon after of every province of the kingdom, except Prussia Proper. The peace of Tilsit restored little more than half the states of the monarchy; and during six years all the calamities of foreign occupation and exaction were accumulated on this ill fated country. Hence the ardor with which the Prussians rushed to arms in 1813; their courage under the first reverses of the campaign, and their perseverance in its prosecution. The peace of Paris in 1814, confirmed by that of 1815, gave them their reward; for, while the Prussian monarch did not obtain the restoration of the same extent of territory in Poland, he had an ample equivalent in Saxony and on the Lower Rhine. Since that period the closest ties of the Prussian court have been with Russia and the Netherlands.

*PRUSSIA PROPER* is a division of the Prussian dominions, having on the one side the northern frontier of Poland, on the other the Baltic. Its form, though irregular, approaches to an oblong, extending from east to west; its superficial extent is nearly equal to that of Scotland. It is in a great measure agricultural, and is composed of the provinces of East and West Prussia, divided formerly by the Vistula, but now by a line a few miles to the east of that river.

*East or Ducal Prussia* lies between 19° 20' and 24° 15' of E. long., and 52° 32' and 56° 3' of N. lat. It has a superficial extent of 15,000 square miles, with 856,000 inhabitants, of whom about a third are of Polish or Lithuanian origin.

It is divided into the governments of Königsberg and Gumbinnen, the latter being the part of Lithuania allotted to Prussia on the partition of Poland. Two-thirds of the population are descendants of Swiss, French, or German protestants. The soil is tolerably productive, but the climate severe, and the spring and autumn changeable and foggy. A great degree of moisture is produced by the lakes, marshes, and vast forests; yet the winds that brush the surface of this country almost without interruption purify the air. The forests are said to cover nearly

3,400,000 acres. They contain bears, elks, and other wild animals common in Poland; they also produce kermes, or, as it is here termed, Russian cochineal. The lakes, great and small, are said to be fully 300 in number. All these abound in fish. Corn of all kinds, as well as flax and hemp, are largely cultivated; hops and madder are reared in particular districts; and potatoes are much used. Hogs are also reared in great numbers, and bees, in a domestic as well as wild state, are in great abundance. The horses are both numerous and of good breeds. The royal studs are now united at the town of Stallupoben, and are said to form the largest establishment of the kind in Europe. Iron ore is found in many of the marshes. Linen, woollen, and in a small degree leather and glass, are the manufactures. The commercial towns are Königsberg and Memel. But the most singular article in this country is amber, currently sold for about three or four shillings the 1 cwt.. The district in which it is obtained from the sea is about twenty-five miles in length. It is thrown on the coast or fished like coral, after strong

north and north-west winds. It is manufactured at Dantzic, Königsberg, and Stolpe, and serves to make trinkets, scented powder, a spirituous acid, and a fine varnishing oil. Part of it is exported to Denmark and Italy, whence, after undergoing a farther process of manufacture, it is sent to Turkey. The quantity annually collected in Prussia is about 200 tons.

*West Prussia* has an area of about 10,000 square miles; its population is 560,000. The foreign settlers here are far less numerous than in East Prussia. It is divided into the governments of Dantzic and Marienwerder. The small part to the right of the Vistula is full of lakes; but along the banks of that river the soil is fertile; in other parts it is sandy and barren.

The agricultural products are similar to those of East Prussia; but the number of cattle is larger. Manufactures, with the exception of linen, are backward; but this province contains the well known commercial towns of Dantzic and Elbing, and possesses in the Vistula a grand channel of communication between Poland and the sea.

PRUSSIC, CYANIC, or HYDROCYANIC, ACID, in chemistry, was first discovered in the pigment commonly called Prussian blue, by Bergman, and first obtained separate by Scheele. The compound formed by this acid with iron was long known and used before its nature was understood. Macquer first found that alkalis would decompose Prussian blue, by separating the iron from the principle with which it was combined, and which he supposed to be phlogiston. Hence the prussiate of potash was long called phlogisticated alkali. Bergman, however, ranked it among the acids; and, as early as 1772, Sage announced that this animal acid, as he called it, formed with the alkalis neutral salts. About the same time Scheele instituted a series of experiments to obtain the acid separate, and to ascertain its constituent principles. These, according to him, are ammonia and carbon; and Beithollet showed that its triple base contains hydrogen and azote, nearly, if not precisely, in the proportions that form ammonia. Berthollet could find no oxygen in any of his experiments for decomposing this acid.

Scheele's method of preparing this acid is this:—Mix four ounces of Prussian blue with two of red oxide of mercury prepared by nitric acid, and boil them in twelve ounces by weight of water, till the whole becomes colorless; then filter and add to it one ounce of clean iron filings, and six or seven drachms of sulphuric acid. Draw off by distillation about a fourth of the liquor, which will be prussic acid, contaminated with a portion of sulphuric; to render it pure, it may be rectified by redistilling it from carbonate of lime.

This prussic acid has a strong smell of peach blossoms, or bitter almonds; its taste is at first sweetish, then acrid, hot, and virulent, and excites coughing; it has a strong tendency to assume the form of gas; it has been decomposed in a high temperature, and by the contact of

light, into carbonic acid, ammonia, and carburetted hydrogen. It does not completely neutralise alkalis, and is displaced even by the carbonic acid: it has no action upon metals, but unites with their oxides, and forms salts for the most part insoluble; it likewise unites into triple salts with these oxides and alkalis.

The peculiar smell of the prussic acid could scarcely fail to suggest its affinity with the poison of the leaves of the lauro-cerasus; and M. Schrader of Berlin has ascertained the fact, that these do contain a principle capable of forming a blue precipitate with iron; and that with lime they afford a test of the presence of iron equal to the prussiate of that earth. Dr. Bucholz of Weimar, and Mr. Roloff of Magdeburg, confirm this fact. The prussic acid appears to come over in the distilled oil.

The following communication to the Royal Society, by Dr. Madden, of Dublin, contains the first proofs of the deleterious effects of this poison upon mankind:—'A very extraordinary accident,' says the Dr., 'has discovered to us a most dangerous poison, which was never before known to be so, though it has been in frequent use among us. This is a simple water, distilled from the leaves of the lauro-cerasus; the water is at first milky, but the oil which comes over, being in a good measure separated from the phlegm, by passing it through a flannel bag, it becomes as clear as common water. It happened that a servant, who lived with a person who sold great quantities of this water, got a bottle of it from her mistress, and gave it to a shop-keeper in town, who she thought might oblige her customers with it. Accordingly, in a few days, she gave about two ounces to a woman called Mary Whaley, who drank about two-thirds and went away. In a quarter of an hour after Mary Whaley had drunk the water, she complained of a violent disorder in her stomach, soon after lost her speech, and died in about an



hour, without vomiting or purging, or any convulsion. The shop-keeper sent word to her sister of what had happened, who came to her upon the message, and affirmed that it was not possible the cordial could have occasioned the death of the woman; and, to convince her of it, she filled out about three ounces and drank it. She continued talking, about two minutes longer, and was so earnest to persuade her of the liquor's being inoffensive, that she drank about two spoonfuls more, but was hardly seated in her chair when she died without the least groan or convulsion. A similar instance, fresh in the memory of every one, is that of Mr. Montgomery, who took one ounce and a half of this acid in Newgate, the night previous to his intended execution for forgery.

The following is the method usually adopted by M. Vauquelin to obtain this acid pure:— To a quantity of powdered Prussian blue diffused in boiling water, let red nitric oxide of mercury be added till the blue color is destroyed. Filter the liquid, and concentrate by evaporation till a pellicle appears. On cooling, crystals of prussiate of mercury will be formed. Dry these, and put them into a tubulated glass retort, to the beak of which is adapted a horizontal tube about two feet long, and half an inch wide at its middle part. The first third part of the tube next the retort is filled with small pieces of white marble, the two other thirds with fused muriate of lime. To the end of this tube is adapted a small receiver, which should be artificially refrigerated. Pour on the crystals muriatic acid, in rather less quantity than is sufficient to saturate the oxide of mercury which formed them. Apply a very gentle heat to the retort. Prussic acid, named *hydrocyanic* by M. Gay Lussac, will be evolved in vapor, and will condense in the tube. Whatever muriatic acid may pass over with it will be abstracted by the marble, while the water will be absorbed by the muriate of lime. By means of a moderate heat applied to the tube, the prussic acid may be made to pass successively along; and, after being left some time in contact with the muriate of lime, it may be finally driven into the receiver. As the carbonic acid evolved from marble by the muriatic is apt to carry off some of the prussic acid, care should be taken to conduct the heat so as to prevent the distillation of this mineral acid.

Prussic acid thus obtained has the following properties:—It is a colorless liquid, possessing a strong odor; and the exhalation, if incautiously snuffed up the nostrils, may produce sickness or fainting. Its taste is cooling at first, then hot, asthenic in a high degree, and it is a most deadly poison. Its specific gravity at  $44\frac{1}{2}^{\circ}$  is 0.7058; at  $64^{\circ}$  it is 0.6969. It boils at  $81\frac{1}{2}^{\circ}$ , and congeals at about  $3^{\circ}$ . It then crystallises regularly, and affects sometimes the fibrous form of nitrate of ammonia. The cold which it produces, when reduced into vapor, even at the temperature of  $68^{\circ}$ , is sufficient to congeal it.

M. Gay Lussac analysed this acid by introducing its vapor at the temperature of  $86^{\circ}$  into a jar, two-thirds filled with oxygen, over warm mercury. When the temperature of the mer-

cury was reduced to that of the surrounding atmosphere, a determinate volume of the gaseous mixture was taken and washed in a solution of potash, which abstracts the prussic acid, and leaves the oxygen. A known volume was introduced into a Volta's eudiometer, with platinum wires, and an electric spark was passed across the gaseous mixture. The combustion is lively, and of a bluish-white color. A white prussic vapor is seen, and a diminution of volume takes place, which is ascertained by measuring the residue in a graduated tube. This, being washed with a solution of potash or barytes, suffers a new diminution from the absorption of carbonic acid gas formed. Lastly, the gas which the alkali has left is analysed over water by hydrogen, and it is ascertained to be a mixture of nitrogen and oxygen.

The following are the results referred to prussic acid vapor:—

Vapor . . . . .	100
Diminution after combustion . . . . .	78.5
Carbonic acid gas produced . . . . .	101.0
Nitrogen . . . . .	46.0
Hydrogen . . . . .	55.0

During the combustion a quantity of oxygen disappears, equal to about one and a quarter of the vapor employed.

M. Gay Lussac also analysed prussic acid by passing its vapor through an ignited porcelain tube containing a coil of fine iron wire, which facilitates the decomposition of this vapor, as it does with ammonia. No trace of oxygen could be found in prussic acid. And again, by transmitting the acid in vapor over ignited peroxide of copper in a porcelain tube, he came to the same conclusion:—

One volume of the vapor of carbon,	
Half a volume of hydrogen,	
Half a volume of nitrogen,	
condensed into one volume; or in weight,	
Carbon . . . . .	44.39
Nitrogen . . . . .	51.71
Hydrogen . . . . .	3.90
	100.00

This acid, when compared with the other animal products, is distinguished by the great quantity of nitrogen it contains, by its small quantity of hydrogen, and especially by the absence of oxygen.

When this acid is kept in well-closed vessels, even though no air be present, it is sometimes decomposed in less than an hour; though it has been occasionally kept for fifteen days without alteration. It begins by assuming a reddish-brown color, which becomes deeper and deeper, and it gradually deposits a considerable carbonaceous matter, which gives a deep color to both water and acids, and emits a strong smell of ammonia. If the bottle containing the prussic acid be not hermetically sealed nothing remains but a dry charry mass, which gives no color to water. Thus a prussiate of ammonia is formed at the expense of a part of the acid, and an azoturet of carbon. When potassium is heated in prussic acid vapor mixed with hydrogen or

nitrogen, there is absorption without inflammation, and the metal is converted into a gray spongy substance, which melts, and assumes a yellow color.

Supposing the quantity of potassium employed capable of disengaging from water a volume of hydrogen equal to fifty parts, we find after the action of the potassium, 1. That the gaseous mixture has experienced a diminution of volume amounting to fifty parts: 2. On treating this mixture with potash, and analysing the residue by oxygen, that fifty parts of hydrogen have been produced: 3. And consequently that the potassium has absorbed 100 parts of prussic vapor; for there is a diminution of fifty parts, which would obviously have been twice as great, had not fifty parts of hydrogen been disengaged. The yellow matter is prussiate of potash; properly a prusside of potassium, analogous in its formation to the chloride and iodide, when muriatic and hydriodic gases are made to act on potassium.

The base of prussic acid, thus divested of its acidifying hydrogen, should be called, agreeably to the same chemical analogy, prussine. M. Gay Lussac styles it cyanogen, because it is the principle which generates blue.

The prusside or cyanide of potassium gives a very alkaline solution in water, even when a great excess of hydrocyanic vapor has been present at its formation. In this respect it differs from the chlorides and iodides of that metal, which are perfectly neutral.

On subjecting prussic acid to the action of a galvanic battery, much hydrogen is disengaged at the negative pole; and prussine or cyanogen at the positive, which remains dissolved in the acid. This compound should be regarded as a hypoprussic or prussous acid. Since potash by heat separates the hydrogen of the prussic acid, we see that in exposing a mixture of potash and animal matters to a high temperature, a true prusside or cyanide of potash is obtained, formerly called the Prussian or phlogisticated alkali. When prusside of potassium is dissolved in water, prussiate of potash is produced, which is decomposed by the acids without generating ammonia or carbonic acid; but, when prusside of potash dissolves in water, no change takes place; and neither ammonia, carbonic acid, nor hydrocyanic vapor is given out, unless an acid be added. These are the characters which distinguish a metallic prusside or cyanide from the cyanide of an oxide.

From the experiments of M. Magendie it appears that the pure prussic acid is the most violent of all poisons. When a rod dipped into it is brought in contact with the tongue of an animal, death ensues before the rod can be withdrawn. If a bird be held a moment over the mouth of a phial containing this acid, it dies. A French professor of chemistry left by accident, on a table, a flask containing alcohol impregnated with prussic acid; the servant, enticed by the agreeable flavor of the liquid, swallowed a small glass of it. In two minutes she dropt down dead, as if struck with apoplexy.

'Scharinger, a professor at Vienna,' says *Offila*, 'prepared a pure and concentrated prus-

sic acid; he spread a certain quantity of it on his naked arm, and died a little time thereafter.'

Dr. Magendie has, however, ventured to introduce its employment into medicine. He found it beneficial against phthisis and chronic catarrhs. His formula is the following:—

Mix one part of the pure prussic or hydrocyanic acid of M. Gay Lussac with eight and a half of water by weight. To this mixture he gives the name of medicinal prussic acid.

Of this he takes	1 gros. or	59 gr. Troy.
Distilled water	1 lb. or	7560 grs.
Pure sugar	1½ ox. or	708½ grs.

And, mixing the ingredients well together, he administers a table-spoonful every morning and evening. A well written report of the use of the prussic acid in certain diseases, by Dr. Magendie, was communicated by Dr. Granville to Mr. Brande, and is inserted in the fourth volume of the *Journal of Science*.

For the following ingenious and accurate process, for preparing prussic acid for medicinal uses, we are indebted to Dr. Nimmo of Glasgow:—

'Take of the ferroproussiate of potash 100 grains, of the protosulphate of iron eighty-four grains and a half; dissolve them separately in four ounces of water, and mingle them. After allowing the precipitate of the protoproussiate of iron to settle, pour off the clear part, and add water to wash the sulphate of potash completely away. To the protoproussiate of iron, mixed with four ounces of pure water, add 135 grains of the peroxide of mercury, and boil the whole till the oxide is dissolved. With the above proportions of peroxide of mercury, the protoproussiate of iron is completely decomposed. The vessel being kept warm, the oxide of iron will fall to the bottom; the clear part may be poured off to be filtered through paper, taking care to keep the funnel covered, so that crystals may not form in it by refrigeration. The residuum may be treated with more water, and thrown upon the filter, upon which warm water ought to be poured, until all the soluble part is washed away. By evaporation, and subsequent rest in a cool place, 145 grains of crystals of the prusside or cyanide of mercury will be procured in quadrangular prisms.

'The following is a new process for obtaining the prussic acid:—Take of the prusside of mercury in fine powder one ounce, diffuse it in two ounces of water, and to it, by slow degrees, add a solution of hydrosulphuret of barytes, made by decomposing sulphate of barytes with charcoal in the common way. Of the sulphuret of barytes take an ounce, boil it with six ounces of water, and filter it as hot as possible. Add this in small portions to the prusside of mercury, agitating the whole very well, and allowing sufficient time for the prusside to dissolve, while the decomposition is going on between it and the hydrosulphuret as it is added. Continue the addition of the hydrosulphuret so long as a dark precipitate of sulphuret of mercury falls down, and even allowing a small excess. Let the whole be thrown upon a filter, and kept warm till the fluid drops through; add more water to wash the

sulphuret of mercury, until eight ounces of fluid have passed through the filter, and it has become tasteless. To this fluid, which contains the prussiate of barytes, with a small excess of hydrosulphuret of barytes, add sulphuric acid, diluted with an equal weight of water, and allowed to become cold, so long as sulphate of barytes falls down. The excess of sulphureted hydrogen will be removed by adding a sufficient portion of carbonate of lead, and agitating very well. The whole may now be put upon a filter, which must be closely covered; the fluid which passes is the hydrocyanic or prussic acid, of what is called the medical standard strength.

Dr. Nimmo finds that prussiae of mercury is capable of dissolving the mercurial peroxide. Hence the above proportions must be strictly observed, if we wish to obtain this powerful medicine of uniform strength. He conceives, therefore, that the ferropussiate of potash should be taken for the basis of the calculation.

Scheele found that prussic acid occasioned precipitates with only the following three metallic solutions; nitrates of silver, and mercury, and carbonate of silver. The first is white, the second black, the third green, becoming blue.

The prussiates or hydrocyanates are all alkaline, even when a great excess of acid is employed in their formation; and they are decomposed by the weakest acids.

The hydrocyanate of ammonia crystallises in cubes, in small prisms crossing each other, or in feathery crystals, like the leaves of a fern. Its volatility is such that at the temperature of  $71\frac{1}{2}^{\circ}$  it is capable of bearing a pressure of 17.72 inches of mercury; and at  $97^{\circ}$  its elasticity is equal to that of the atmosphere. Its great volatility prevented M. Gay Lussac from determining the proportion of its constituents. M. Gay Lussac considers Prussian blue as a hydrated prusside of iron, or a cyanide having water in combination; and M. Vauquelin, in a memoir lately read before the Academy of Sciences, regards Prussian blue as a simple hydrocyanate of iron. He finds that water impregnated with prussine can dissolve iron without changing it into Prussian blue, and without the disengagement of any hydrogen gas, while Prussian blue was left in the undissolved portion. But prussic acid converts iron or its oxide into Prussian blue without the help either of alkalis or acids. He farther lays it down as a general rule, that those metals which, like iron, decompose water at the ordinary temperature of the atmosphere, form hydrocyanates; and that those metals which do not possess this power, as silver and quicksilver, form only cyanides.

Prussic acid is easily separated from potash by carbonic acid, but, when oxide of iron is added to the compound, a triple salt is formed, usually called ferropussiate of potash. The method of preparing this salt practised by Klaproth is one of the best. It is as follows:—Prepare pure potash, by gradually projecting into a large crucible, heated to whiteness, a mixture of equal parts of purified nitre and crystals of tartar; when the whole is injected, let it be kept at a white heat for half an hour, to burn off the coal. Detach the alkali thus obtained from the

crucible, reduce it to powder, spread it on a muffle, and expose it to a white heat for half an hour. Dissolve it in six times its weight of water, and filter the solution while warm. Pour this solution into a glass receiver, placed in a sand furnace, heated to  $170^{\circ}$  or  $180^{\circ}$ , and then gradually add the best Prussian blue in powder, injecting new portions of it as the former becomes gray, and supplying water as fast as it evaporates; continue until the added portions are no longer discolored; then increase the heat to  $212^{\circ}$ , and continue for half an hour. Filter the ley thus obtained, and saturate it with sulphuric acid moderately diluted; a precipitate will appear: when this ceases, filter off the whole, and wash the precipitate. Evaporate the filtered liquor to about one quarter and set it by to crystallise: after a few days, yellowish crystals of a cubic or quadrangular form will be found mixed with some sulphate of potash and oxide of iron; pick out the yellowish crystals, lay them on blotting paper, and redissolve them in four times their weight of cold water, to exclude the sulphate of potash. Essay a few drops of this solution with a solution of barytes, to see whether it contains any sulphuric acid: filter off the solution from the sulphate of barytes, which will have precipitated, and set it by to crystallise for a few days, that the barytes, if any should remain, may be precipitated. If the crystals now obtained be of a pale yellow color, and discover no bluish streaks, when sprinkled over with muriatic acid, they are fit for use, and should be kept in a well stopped bottle, which, to preserve them from the air, should be filled with alcohol, as they are insoluble in it.

M. Gay Lussac prepared a hydrocyanate of potash and silver, which was quite neutral, and which crystallised in hexagonal plates. The solution of these crystals precipitates salts of iron and copper, white. Muriate of ammonia does not render it turbid; but muriatic acid, by disengaging hydrocyanic acid, precipitates chloride of silver. Sulphureted hydrogen produces in it an analogous change. This compound, says M. Gay Lussac, is evidently the triple prussiate of potash and silver; and its formation ought to be analogous to that of the other triple hydrocyanates. 'And as we cannot doubt,' adds he, 'that hydrocyanate of potash and silver is in reality, from the mode of its formation, a compound of cyanide of silver and hydrocyanate of potash, I conceive that the hydrocyanate of potash and iron is likewise a compound of neutral hydrocyanate of potash, and subcyanide of iron, which I believe to be combined with hydrocyanic acid in the white precipitate. We may obtain it perfectly neutral, and then it does not decompose alum; but the hydrocyanate of potash, which is always alkaline, produces in it a light and flocculent precipitate of alumina. To the same excess of alkali we must ascribe the ochry color of the precipitates which hydrocyanate of potash forms with the persalts of iron.'

M. Vauquelin has given the following very elegant process for obtaining pure hydrocyanic or prussic acid, from the cyanide or prusside of mercury:—

Considering that mercury has a strong attrac-

tion for sulphur, and that prussine unites easily to hydrogen, when presented in the proper state, he thought that sulphureted hydrogen might be employed for decomposing dry cyanide (prusside) of mercury. He operated in the following way:—He made a current of sulphureted hydrogen gas, disengaged slowly from a mixture of sulphuret of iron, and very dilute sulphuric acid, pass slowly through a glass tube slightly heated, filled with the mercurial prusside, and communicating with a receiver, cooled by a mixture of salt and snow.

As soon as the sulphureted hydrogen came in contact with the mercurial salt, this last substance blackened, and this effect gradually extended to the farthest extremity of the apparatus. During this time no trace of sulphureted hydrogen could be perceived at the mouth of a tube proceeding from the receiver. As soon as the odor of this gas began to be perceived, the process was stopped; and the tube was heated in order to drive over the acid which might still remain in it. The apparatus being unluted, he found in the receiver a colorless fluid, which possessed all the known properties of prussic acid. It amounted to nearly the fifth part of the prusside of mercury employed.

This process is easier, and furnishes more acid, than M. Gay Lussac's, by means of muriatic acid. He repeated it several times, and always successfully. It is necessary merely to take care to stop the process before the odor of the sulphureted hydrogen begins to be perceived, otherwise the hydrocyanic acid will be mixed with it. However, we may avoid this inconvenience by placing a little carbonate of lead at the extremity of the tube. As absolute hydrocyanic acid is required only for chemical researches, and as it cannot be employed in medicine, it may be worth while, says M. Vauquelin, to bring to the recollection of apothecaries a process of M. Proust, which has perhaps escaped their attention. It consists in passing a current of sulphureted hydrogen gas through a cold saturated solution of prussiate of mercury in water, till the liquid contains an excess of it; to put the mixture into a bottle, in order to agitate it from time to time; and finally, to filter it.

If this prussic acid, as almost always happens, contains traces of sulphureted hydrogen, agitate it with a little carbonate of lead, and filter it again. By this process we may obtain hydrocyanic acid in a much greater degree of concentration than is necessary for medicine. It has the advantage over the dry prussic acid, of being capable of being preserved a long time, always taking care to keep it as much as possible from the contact of air and heat. Dr. Nimmo's directions for preparing the prusside of mercury ought to be attended to.

PRUSSINE, or PRUSSIC GAS, in chemistry, the cyanogen of M. Gay Lussac, is a peculiar gas obtained by decomposing prusside of mercury by heat. The term cyanogen signifies the produce of blue; but as the production of blue is never the result of the direct action of this substance on any other single body, but an indirect and unexplained operation of it in conjunction with iron, hydrogen, and oxygen, the

same reason which leads to the term cyanogen, would warrant us in calling it leucogen, erythrogen, or chlorogen; for it produces, white, red, or green, with other metals, as it produces blue with iron.

By digesting red oxide of mercury with prussian blue and hot water, we obtain a prusside perfectly neutral, which crystallises in long four-sided prisms, truncated obliquely. By repeated solutions and crystallisations, we may free it from a small portion of adhering iron. But M. Gay Lussac prefers boiling it with red oxide of mercury, which completely precipitates the oxide of iron, and he then saturates the excess of oxide of mercury with a little prussic acid, or a little muriatic acid. The prusside thus formed is decomposed by heat to obtain the radical. For common experiments we may dispense with these precautions.

When this cyanide is boiled, with red oxide of mercury, it dissolves a considerable quantity of the oxide, becomes alkaline, crystallises no longer in prisms, but in small scales, and its solubility in water appears a little increased. When evaporated to dryness, it is very easily charred, which obliges us to employ a water bath. This compound was observed by M. Proust. When decomposed by heat, it gives abundance of prussine, but mixed with carbonic acid gas. Proust says that it yields ammonia, oil in considerable abundance, carbonic acid, azote, and oxide of carbon. He employed a moist prusside. Had it been dry, the discovery of prussine could hardly have escaped him. The prusside of mercury, when neutral and quite dry, gives nothing but prussine; when moist, it furnishes only carbonic acid, ammonia, and a great deal of prussic acid vapor. When we employ the prusside made with excess of peroxide, the same products are obtained, but in different proportions, along with azote, and a brown liquid, which Proust took for an oil, though it is not one in reality. Hence, to obtain pure prussine, we must employ the neutral prusside in a state of perfect dryness. The other mercurial compound is not, however, simply a sub-prusside. It is a compound of oxide of mercury and the prusside.

When the simple mercurial prusside is exposed to heat in a small glass retort, or tube, shut at one extremity, it soon begins to blacken. It appears to melt like an animal matter, and then the prussine is disengaged in abundance. This gas is pure from the beginning of the process to the end, provided always that the heat be not very high; for, if it were sufficiently intense to melt the glass, a little azote would be evolved. Mercury is volatilised with a considerable quantity of prusside, and there remains a charry matter of the color of soot, and as light as lampblack. The prusside of silver gives out likewise prussine when heated; but the mercurial prusside is preferable to every other.

Prussine or cyanogen is a permanently elastic fluid. Its smell, which it is impossible to describe, is very strong and penetrating. Its solution in water has a very sharp taste. The gas burns with a bluish flame mixed with purple. Its specific gravity, compared to that of air, is 1.8064. M. Gay Lussac obtained it by weigh-

ing at the same temperature, and under the same pressure, a balloon of about two litres and a half (152.56 cubic inches), in which the vacuum was made to the same degree, and alternately full of air and prussine. 100 cubic inches weigh therefore 55.1295 grains.

Prussine is capable of sustaining a pretty high heat, without being decomposed. Water, with which M. Gay Lussac agitated it for some minutes, at the temperature of 68°, absorbed about four times and a half its volume. Pure alcohol absorbs twenty-three times its volume. Sulphuric ether and oil of turpentine dissolve at least as much as water. Tincture of litmus is reddened by prussine. On heating the solution the gas is disengaged, mixed with a little carbonic acid, and the blue color of the litmus is restored. The carbonic acid proceeds no doubt from the decomposition of a small quantity of prussine and water. It deprives the red sulphate of manganese of its color, a property which prussic acid does not possess. This is a proof that its elements have more mobility than those of the acid. In the dry way it separates the carbonic acid from the carbonates.

Phosphorus, sulphur, and iodine, may be sublimed by the heat of a spirit-lamp in prussine, without occasioning any change on it. Its mixture with hydrogen was not altered by the same temperature, or by passing electrical sparks through it. Copper and gold do not combine with it; but iron, when heated almost to whiteness, decomposes it in part. The metal is covered with a slight coating of charcoal, and becomes brittle. The undecomposed portion of the gas is mixed with azote (contains free azote). In one trial the azote constituted 0.44 of the mixture, but in general it was less. Platinum, which had been placed beside the iron, did not undergo any alteration. Neither its surface, nor that of the tube, was covered with charcoal like the iron.

In the cold, potassium acts but slowly on prussine, because a crust is formed on its surface, which presents an obstacle to the mutual action. On applying the spirit-lamp, the potassium becomes speedily incandescent; the absorption of the gas begins, the inflated disc gradually diminishes, and when it disappears entirely, which takes place in a few seconds, the absorption is likewise at an end. Supposing we employ a quantity of potassium that would disengage fifty parts of hydrogen from water, we find that from forty-eight to fifty parts of gas have disappeared. On treating the residue with potash, there usually remains four or five parts of hydrogen, sometimes ten or twelve. M. Gay Lussac made a great number of experiments to discover the origin of this gas. He thinks that it is derived from the water which the prusside of mercury contains when it has not been sufficiently dried. Prussic acid vapor is then produced, which, when decomposed by the potassium, leaves half its volume of hydrogen. Potassium, therefore, absorbs a volume of pure prussine, equal to that of the hydrogen which it would disengage from water.

The compound of prussine and potassium is yellowish. It dissolves in water without effer-

vescence, and the solution is strongly alkaline. Its taste is the same as that of hydrocyanate or simple prussiate of potash, of which it possesses all the properties.

The gas being very inflammable, M. Gay Lussac exploded it in Volta's eudiometer, with about twice and a half its volume of oxygen. The detonation is very strong; and the flame is bluish, like that of sulphur burning in oxygen.

It is now obvious that the action of potassium on prussine agrees with its action on prussic acid. We have seen that it absorbs fifty parts of the first, and likewise that it absorbs 100 parts of the second, from which it separates fifty parts of hydrogen. But 100 parts of prussic acid vapor, minus fifty parts of hydrogen, amount exactly to fifty parts prussine. Hence the two results agree perfectly, and the two compounds obtained ought to be identical, which agrees precisely with experiment.

The analysis of prussine being of great importance, M. Gay Lussac attempted it likewise by other methods. Having put prusside of mercury into the bottom of a glass tube, he covered it with brown oxide of copper, and then raised the heat to a dull red. On heating gradually the part of the tube containing the prusside, the prussine was gradually disengaged, and passed through the oxide, which it reduced completely to the metallic state. On washing the gaseous products with aqueous potash, at different parts of the process, he obtained only from 0.19 to 0.30 of azote, instead of 0.33, which ought to have remained according to the preceding analysis. Presuming that some nitrous compound had been formed, he repeated the experiment, covering the oxide with a column of copper filings, which he kept at the same temperature as the oxide. With this new arrangement, the results were very singular; for the smallest quantity of azote which he obtained during the whole course of the experiment was 32.7 for 100 of gas, and the greatest was 34.4. The mean of all the trials was,—

Azote . . . . .	33.6 or nearly 1
Carbonic acid . . . . .	66.4            2

A result which shows clearly that prussine contains two volumes of the vapor of carbon, and one volume of azote.

In another experiment, instead of passing the prussine through the oxide of copper, he made a mixture of one part of the prusside of mercury, and ten parts of the red oxide, and after introducing it into a glass tube, close at one end, he covered it with copper filings, which he raised first to a red heat. On heating the mixture successively, the decomposition went on with the greatest facility. The proportions of the gaseous mixture were less regular than in the preceding experiment. Their mean was,—

Azote . . . . .	34.6 instead of 33.3
Carbonic acid . . . . .	65.4            66.6

In another experiment he obtained,—

Azote . . . . .	32.2
Carbonic acid . . . . .	67.8

Now the mean of these results gives,—

Azote . . . . .	33.4
Carbonic acid . . . . .	66.6

No sensible quantity of water seemed to be formed during these analyses. This shows farther that what has been called a prussiate of mercury is really a prusside of that metal.

When a pure solution of potash is introduced into this gas, the absorption is rapid. If the alkali be not too concentrated, and be not quite saturated, it is scarcely tinged of a lemon-yellow color. But, if the prussine be in excess, we obtain a brown solution, apparently carbonaceous. On pouring potash combined with prussine into a saline solution of black oxide of iron, and adding an acid, we obtain prussian blue. It would appear from this phenomenon that the prussine is decomposed the instant that it combines with the potash: but this conclusion is premature; for, when this body is really decomposed by means of an alkaline solution, carbonic acid is always produced, together with prussic acid and ammonia. But on pouring barytes into a solution of prussine in potash, no precipitate takes place, which shows that no carbonic acid gas is present. On adding an excess of quicklime, no trace of ammonia is perceptible. Since, then, no carbonic acid and ammonia have been formed, water has not been decomposed, and consequently no prussic acid evolved. How then comes the solution of prussine in potash to produce prussian blue, with a solution of iron and acid? The following is M. Gay Lussac's ingenious solution of this difficulty:—

The instant an acid is poured into the solution of prussine in potash, a strong effervescence of carbonic acid is produced, and at the same time a strong smell of prussic acid becomes perceptible. Ammonia is likewise formed, which remains combined with the acid employed, and which may be rendered very sensible to the smell by the addition of quicklime. Since, therefore, we are obliged to add an acid in order to form prussian blue, its formation occasions no farther difficulty.

Prussine rapidly decomposes the carbonates at a dull red heat, and prussides of the oxides are obtained. When passed through sulphuret of barytes, it combines without disengaging the sulphur, and renders it very fusible, and of a brownish black color. When put into water we obtain a colorless solution, but which gives a deep brown (maroon) color to muriate of iron. What does not dissolve contains a good deal of sulphate, which is doubtless formed during the preparation of the sulphuret of barytes.

On dissolving prussine in the sulphureted hydrosulphuret of barytes, sulphur is precipitated, which is again dissolved when the liquid is saturated with prussine, and we obtain a solution having a very deep brown maroon color. This gas does not decompose sulphuret of silver, nor of potash.

Prussine and sulphureted hydrogen combine slowly with each other. A yellow substance is obtained in fine needles, which dissolves in water, does not precipitate nitrate of lead, produces no prussian blue, and is composed of one volume prussine (cyanogen), and one volume and a half of sulphureted hydrogen.

Ammoniacal gas and prussine begin to act on each other whenever they come in contact; but

some hours are requisite to render the effect complete. We perceive at first a white thick vapor, which soon disappears. The diminution of volume is considerable, and the glass in which the mixture is made becomes opaque, its inside being covered with a solid brown matter. On mixing ninety parts of prussine, and 227 ammonia, they combined nearly in the proportion of one to one and a half. This compound gives a dark orange-brown color to water, but dissolves only in a very small proportion. The liquid produces no prussian blue with the salts of iron.

When prussic acid is exposed to the action of a voltaic battery of twenty pairs of plates, much hydrogen gas is disengaged at the negative pole, while nothing appears at the positive pole. It is because there is evolved at that pole prussine, which remains dissolved in the acid.

A portion of pure cyanide of mercury was heated by Faraday till perfectly dry, and then enclosed in a green glass tube, and, being collected to one end, was decomposed by heat, whilst the other end was cooled. The cyanogen soon appeared as a liquid, limpid, colorless, and very fluid; not altering its state at 0° Fahr. A tube containing it being opened in the air, the expansion within did not seem to be very great; and the liquid passed with comparative slowness into the state of vapor, producing great cold. The vapor collected over mercury proved to be pure cyanogen. Liquid cyanogen, evolved in contact with moisture, does not mix with the water, but floats over it. In a few days the water and cyanogen react on each other, and carbonaceous matter is evolved. Faraday, Phil. Trans. 1823.

In the first volume of the Journal of Science and the Arts, Sir H. Davy has stated some interesting particulars relative to prussine. By heating prusside of mercury in muriatic acid gas, he obtained pure liquid prussic acid, and corrosive sublimate. By heating iodine, sulphur and phosphorus, in contact with prusside of mercury, compounds of these bodies with prussine or cyanogen may be formed. That of iodine is a very curious body. It is volatile at a very moderate heat, and on cooling collects in flocculi, adhering together like oxide of zinc formed by combustion. It has a pungent smell, and very acrid taste.

PRUTH, a considerable river of Europe, which rises in the palatinate of Marmarosch, Hungary, and forms the boundary between the Russian and Turkish dominions in Moldavia, falling into the Danube below Galatz. It is remarkable for the perilous situation of the Russian army under Peter I. in 1712, from which it was extricated by a treaty with the Turkish vizier.

PRY, *v. n.* Perhaps of Span. *perojar*, to observe. To peep narrowly; inspect curiously or impertinently.

He that prieth in at her windows, shall also hearken at her doors. *Eccles. xiv. 23.*

I can counterfeit the deep tragedian,  
Speak, and look back, and pry on every side,  
Intending deep suspicion.

*Shakspeare. Richard III.*

Nor need we with a prying eye survey  
The distant skies to find the milky way. *Creech.*

I waked, and, looking round the bow'r,  
Searched ev'ry tree, and pry'd on every flow'r,  
If any where by chance I might espy  
The rural poet of the melody.

*Dryden.*

We have naturally a curiosity to be prying and  
searching into forbidden secrets.

*L'Estrange.*

All these I frankly own without denying;  
But where has this Praxiteles been prying?

*Addison.*

PRYNNE (William), an English lawyer, who greatly distinguished himself in the civil commotions under Charles I., was born at Swainswick, in Somersetshire, in 1600. His *Histriomastix*, written against stage plays in 1632, containing some reflections that offended the court, he was sentenced by the star-chamber to pay a fine of £5000, to stand in the pillory, to lose his ears, and to perpetual imprisonment. During his confinement, he wrote several more books; particularly, in 1637, one entitled *News from Ipswich*, which reflecting severely on the bishops, he was again sentenced by the star-chamber to another fine of £5000, to lose the remainder of his ears in the pillory, to be branded on both cheeks with S. L. for seditious libeller, and to be perpetually imprisoned in Caernarvon castle. Nothing however could intimidate the stubborn spirit of Prynne, he continued to write, and in 1640, being set at liberty by the house of commons, he entered London in a kind of triumph, was elected into parliament for Newport in Cornwall, and opposed the bishops with great vigor, being the chief manager of archbishop Laud's trial. In the long parliament he was zealous in the Presbyterian cause; but, when the Independents gained the ascendancy, he opposed them warmly, and promoted an agreement with the king. When the army divided the house, and refused him entrance, he became a bitter enemy to them and their leader Cromwell, and attacked them with his pen so severely that he was again imprisoned: but he pleaded the liberty of the subject so successfully that he was enlarged. Being restored to his seat after Cromwell's death, with the other secluded members, he assisted in promoting the restoration, and was appointed keeper of the Tower records; where he was very useful by the collections he published from them. He presented forty volumes of his works, in folio and 4to., to Lincoln's Inn library, of which society he was a member; and, dying in 1669, was buried under the chapel.

PRYTANES, in Grecian antiquity, were the presidents of the senate, whose authority consisted chiefly in assembling the senate; which, for the most part, was done once every day. The senate consisted of 500, fifty senators being elected out of each tribe: after which lots were cast, to determine in what order the senators of each tribe should preside; which they did by turns, and during their presidentship were called prytanes. However, all the fifty prytanes of the tribes did not govern at once, but one at a time, viz. for seven days; and, after thirty-five days, another tribe presided for other five weeks, and so of the rest.

PRZEMYSŁ, a circle and town of Austrian Poland, in the centre of that country, to the west of the circle of Lemberg. Its area is 1420

square miles, population of the circle about 212,000, of the town 7500; the former consists of a vast plain, traversed nearly throughout its extent by the river San; and watered by a number of other minor streams. The surface is occasionally diversified by gentle elevations and woods. The only manufacture is a coarse linen and leather. The town is the see both of a Greek and Catholic bishop.

PRZIBRAM, a town in the west of Bohemia, near silver and lead mines, nineteen miles south of Beraun, and thirty-three S. S. W. of Prague. Population 2300.

PRZIPIKA, the greatest river in the east of Poland, is joined partly by a canal, partly by the stream of the Muchawica, to the Bug and Vistula, the great rivers of the central part of that kingdom, and after flowing west falls into the Dnieper forty miles above Kiev.

PRZIPCOWIUS (Samuel), a learned Socinian writer, born in 1590, who was driven from Poland with many others of that sect in 1638. He took refuge in Prussia, where he died in 1670, aged eighty. His works are inserted in the collection of Socinian writers published in 1656, in 9 vols. folio.

PSALM, *n. s.* } Fr. *psalme, pseume*; Gr. }  
PSALMIST, } *ψαλμος*. A holy song: psalm-  
PSALTER, } ist is the author of such a  
PSALTERY. } song: psalms, a collection  
of psalms: psaltery, a harp on which they are played.

Praise with trumpets, pierce the skies,  
Praise with harps and psalteries.

*Sandys's Paraph.*

The choice and flower of all things profitable in other books, the *psalms* do both more briefly contain and more movingly express, by reason of that poetical form wherewith they are written.

*Hooker.*

The trumpets, sacbut, psalteries, and fife,

Make the sun dance. *Shakspeare. Coriolanus.*

Sternhold was made groom of the chamber, for turning certain of David's *psalms* into verse.

*Peacham.*

The sweet singer of Israel with his psaltery, loudly resounded the benefits of the Almighty Creator.

*Id.*

Those just spirits that wear victorious palms,  
Hymns devote and holy psalms  
Singing continually

*Milton*

In another *psalm* he speaks of the wisdom and power of God in the creation.

*Burnet.*

How much more rational is this system of the *psalmist*, than the Pagan's scheme in Virgil, where one deity is represented as raising a storm, and another as laying it!

*Addison.*

Nought shall the psaltery and the harp avail,  
When the quick spirits their warm march forbear,  
And numbing coldness has unbraced the ear.

*Prior.*

She, her daughters, and her maids, meet together at all the hours of prayer in the day, and chaunt *psalms*, and other devotions, and spend the rest of their time in such good works, and innocent diversions, as render them fit to return to their *psalms* and prayers.

*Law.*

PSALMS, BOOK OF, a canonical book of the Old Testament. Most of the psalms have particular titles, signifying either the name of the author, the person who was to set it to music or sing it, the instrument that was to be used, or

the subject and occasion of it. Many of the psalms are inscribed with the names Korah, Jeduthun, &c., from the persons who were to sing them.

PSALMANAZAR (George), the name assumed by a very extraordinary character, born in France and educated in a Jesuit's College: upon leaving which, he led the life of a pilgrim. At Liege he entered into the Dutch service, and afterwards into that of Cologne. In the habit of a pilgrim he begged through several countries, in elegant Latin, and, accosting only gentlemen and clergymen, received liberal supplies, which he spent as freely. In Germany he passed for a native of Formosa, a convert to Christianity, and a sufferer for it. At Sluys he fell in with brigadier Lauder, a Scots colonel, who introduced him to the chaplain; who, to recommend himself to the bishop of London, took him over to that city. The bishop patronised him with credulous humanity, and a large circle of his great friends patronised him as a prodigy. He published a History of Formosa, and invented a character and language for that island, and translated the church catechism into it, which was examined by learned critics and approved. Some of the learned, however, doubted him, particularly Drs. Halley, Mead, and Woodward. He was allowed the use of the Oxford library, and employed in compiling the Universal History. Some errors in his History of Formosa first led him to be suspected as an impostor. He died in 1753, and in his last will confessed the imposture.

PSALMODY. The act or practice of singing holy songs was always esteemed a considerable part of devotion. The plain song was early used, being a gentle inflection of the voice, not much different from reading, like the chant in cathedrals; at other times more artificial compositions, like our anthems. Sometimes a single person sung alone; sometimes the whole assembly joined together, which was the most ancient and general practice. At other times, as in those of king David, the psalms were sung alternately, the congregation dividing themselves into parts, and singing verses in turns. There was a fourth way of singing, pretty common in the fourth century, which was, when a single person began the verse, and the people joined with him in the close; this was often used for variety in the same service with alternate psalmody. The use of musical instruments, in the singing of psalms, seems to be as ancient as psalmody itself; the first psalm we read of being sung to the timbrel, viz. that of Moses and Miriam, after the deliverance of the Israelites from Egypt: and afterwards musical instruments were in constant use in the temple of Jerusalem. See ORGAN.

In the early ages of Christianity much was done by the priests to mystify the principles of the various branches of psalmody, and the arts and sciences in general, in order more effectually to keep the common people in ignorance, and consequently in superstition. To create the greater reverence for the church and its priests, who were alone supposed capable of understanding its sacred mysteries, psalmody was carefully inculcated in the minds of youth as of divine

origin, and thoroughly to be understood only by actual inspiration. Ecclesiastical modes of accentuation were adopted in the reading of the gospels, epistles, &c.; and, for the performance of those parts of the divine worship which were sung rather than thus musically or artificially declaimed (see article MUSIC, p. 280), the authentic, and, 300 years afterwards, the plagal modes of the ancient Greeks were introduced into the church by Gregory VIII. He declared that, to ensure the perfect development of his principles of psalmody, he was duly inspired by God. These difficulties, together with the syllabic nature of their music, to suit the rythmical structure of the words, the exact performance of which required the utmost attention to acquire, excluded all participation on the part of the people in praising their Maker, but through the medium of the priests: a principle which, for ages, proved a most powerful engine of priestcraft. Of these ecclesiastical accentuations an idea may be formed, though but a faint one, for they are but mere shadows of them, by attending our cathedral service; they were formerly expressed by a number of signs, termed *pes flexus*, *pes sinuosus*, *pes gutturalis*, *quassus*, *resupinus*, *quillissimi*, &c., each of which designated a peculiar inflexion of the human voice.

With the exception of the Metzian hymns, which, from their popularity, are supposed to have partaken much of the principles of natural melody, and written by Benoit, who established himself at Metz soon after the return of Charlemagne from Rome (a specimen of which style we have inserted in our article MUSIC), the principles appertaining to syllabic music were maintained unimpaired, in the church of Rome, up to the eighteenth century, to the total exclusion of musical rhythm: and, notwithstanding the rapid progress of the arts and sciences after the extinction of the Bards and Druids, it was not before the first dawning of the reformation that melody, independently of absolute prosodial quantity and accentuation, was generally introduced into the divine service, when, as may be expected, the grand distinction took place between the Protestant and Catholic modes of psalmody. The *fauxbourdons* of the Roman church are however still adopted by the Protestants of Germany and Switzerland, both in the modern as well as in the ancient modes; a species of music brought to the highest pitch of excellence in the pontificate of Marcellus, by Palestrina and others; though of late, even amongst the Catholics themselves, such have been the mutations of their ideas relative to ecclesiastical music, these compositions have been allowed to be superseded by others totally of an opposite description, as the performance of the works of Haydn, Mozart, Rhigini, &c., has abundantly testified; thus completing a revolution which, but fifty years ago, would not have been anticipated without feelings of horror and disgust.

In the church of England the system of psalmody in four parts has been of late generally superseded by adhering to one, in which all classes may with facility join. It is nevertheless susceptible of great improvement, as we shall endeavour presently to show. But,



as the understanding of the principles of music, like those of painting, depends more upon example than precept, one good specimen of either conveying more to the mind, the eye, or ear, than volumes, we have but little more to offer upon this subject than what has been stated in substance in our article Music.

With respect to the proper mode of singing, that is to be preferred which best tends to induce the people assembled for the purpose of praising their Maker to join with the greatest ease, devotion, and dignity: singing in parts constituting a system, which, whilst it precludes the possibility of congregational psalmody, can only be effected with tolerable decency, by the hiring of persons to do that which we are in fact commanded to do for ourselves. The first point to be attended to is propriety of articulation; this is effected by warbling steadily on the vowel, and quickly pronouncing the consonant: singing being only a lengthening of the mode of speech. The necessity of this observation will immediately be felt in the singing of the following lines from Dr. Watts,

'Their captive sons, exposed to scorn,' &c.,

When, if we endeavour to warble upon the consonant, no tone can be produced, neither can any sense be given to the melody or words; dwelling, on the contrary, upon the vowels, and quickly pronouncing the consonants, the air is set in motion, a tune is formed, and the words thoroughly understood and felt, more especially when the congregation joins in the manner commended by the ritual, which the reader will pardon us if we observe, consists neither in the boisterous vociferation, as if in glorification of our noisy powers, too often observed in dissenting meetings, nor in the gross indifference so prevalent in the church of England.

Of the two modes upon which all modern music is composed, the major one, being the simplest to understand, is to be preferred; but great advantages will be obtained in the formation of psalm-tunes upon the other modes of the ancient Greeks, the adoption of which added greatly to the celebrity of their extraordinary, most powerful, and varied music, as compared with our own; for the truth of this remark we need only refer the reader to our article Music, where the powers of the different Grecian modes are made evident in our practical illustration of the principles of Scottish music. The mixt Lydian mode, comprising the notes from G to G of our diatonic scale of C, making the half-tones fall between the third and fourth, and sixth and seventh intervals, instead of the third and fourth, and seventh and eighth, intervals of the octave, mingles well with the harmonic powers of the organ, though it is best felt when employed in the construction only of melody. The Lydian mode or measure, which has been supposed by many writers to have been lost to us, is precisely our scale of F major; the same may be said of the Ionian, transposed a fourth lower than the Lydian measure. Excepting the Æolian mode, which is our descending minor scale, these are the only modes capable of receiving the principles of harmonic support. The Dorian mode,

and the melodious Phrygian, are formed of materials entirely different from all others; and, being remarkable as rejecting all harmonic support, are peculiarly serviceable for places of worship where there are no organs, or where the mode of worship rejects the use of musical instruments to accompany the singing of the psalms and hymns.

As the musical staff and clef were inserted to express the different compasses of the human voice, and as all appreciable musical sound is expressed within the limits of the octave, and one note, termed the ninth (the replication of the second of the scale), it follows that melody suitable for psalmody must, of all species of music, be the easiest to comprehend. The principal points of attention, in the Lydian and Ionian measures, are the situations of the two half-tones denominated in solmisation *mi fa*, and, in the disjoined tetrachordal order, C sound, forming the modern major scale, *mi fa* and *si do*, thus: C D E f G A B c (the capitals denoting tones, and the Romans half-tones). This scale, so simple in its construction, and so strictly conformable to the feelings of every one possessing a musical ear, is sufficient to explain the whole mysteries of modern psalmody: the alteration of one or the other of the half-tones constituting the means whereby modulation is effected into the dominant, sub-dominant, and relative minor of the primitive key, which are the utmost limits assigned for the composition of psalmody. The principles also of any well regulated melody in others of the Grecian modes are to be acquired with equal facility; the being habituated to the major and minor systems of sound causing the ancient modes in general to be only momentarily difficult to adopt. To prove this assertion we notice the known secular, for want of a sacred, melody, 'Scots wha hae,' which is written in the mixt Lydian mode of the ancient Greeks.

On the variety of opinions published about the latter end of the sixteenth century upon the use and abuse of psalmody in churches, and of the efforts of many writers to prove the impropriety of its introduction in the reformed church, as a relic only of monkish superstition, we need not offer a comment. According to the Scriptures it has always formed, together with instrumental accompaniments, a part of the divine service: and, sanctioned by the most enlightened men of the age, it prevails universally. Upon the subject of interludes, voluntaries, &c., 'interruptions of the divine service,' as they have often been fairly designated, we would observe that they were adopted in the church as early as the time of St. Ambrose, and that in cases where the organist confines himself to the performance of the sacred compositions of Handel, Graun, Mozart, Marcello, &c., and, in the composition of his interludes, strictly regulates his melody according to the style of the psalm tune, improper associations of ideas could not be raised in the minds even of the most fastidious; on the contrary, they are known to create a tone of feeling highly proper for the occasion. Having, in our article ORGAN, sufficiently explained our sentiments on the abuses of extemporaneous perfor-

stances, and of the immoral tendency of introducing secular music into the church, we cannot better conclude this article, than by recommending to the heads of our ecclesiastical affairs, the establishment of one collection of psalm tunes to be sung throughout the established church: such a regulation would surely prove not less useful than one form of prayer; at least the parishioners of one church would then have the advantage of joining in this part of the divine service with facility at another, which, from the strange mixture of musical styles observed at the different churches, is now become impossible.

The PSALTERY was a musical instrument much in use among the ancient Hebrews, who called it *nebel*; but we know little or nothing of the precise form of the ancient psaltery. See MUSIC.

PSAMMETICUS, or PSAMMETICHUS, a renowned conqueror, who subduing eleven other petty kings of Egypt became the founder of a new dynasty in the kingdom of Egypt, about 670 B. C. He is memorable likewise for taking the city of Azot, after a siege of twenty-nine years.

PSATYRIANS, a sect of Arians, who, in the council of Antioch, held in the year 360, maintained that the Son was not like the Father as to will; that he was taken from nothing, or made of nothing; and that in God generation was not to be distinguished from creation.

PSELLUS (Michael Constantine), a learned Christian of the eleventh century, was, by birth, a Constantinopolitan of consular rank, and flourished under the emperor Constantine Monomachus. He was the chief instructor of the Constantinopolitan youth, and at the same time the companion and the preceptor of the emperor. Towards the close of his life, Psellus retired into a monastery, and soon afterwards died. His works, which have been much celebrated, are, Commentaries upon Aristotle's Logic and Physics; a Compendium of Questions and Answers; and an Explanation of the Chaldean Oracles.

PSEUDO, *n. s.* From Gr. *ψευδος*. A prefix, which signifies false or counterfeit: as pseudo-apostle, a counterfeit apostle.

I will not pursue the many *pseudographies* in use, but show of how great concern the emphasis were, if rightly used.

It is not according to the sound rules of *pseutology*, to report of a pious prince, that he neglects his devotion, but you may report of a merciful prince, that he has pardoned a criminal who did not deserve it.

*Arbutnot.*

PSHAW, *interj.* An expression of contempt. A peevish fellow has some reason for being out of humour, or has a natural incapacity for delight, and therefore disturbs all with pishes and *psaws*.

*Spectator.*

PSIDIUM, the guava, or bay plum, a genus of the monogynia order, and icosandria class of plants; natural order nineteenth, hesperideæ: CAL. quinquefid, superior; there are five petals; the berry is unilocular and monospermous. There are two species:

1. *P. pomiferum*, the red guava; and 2. *P. pyriferum*, the white guava. The red guava

rises to twenty feet, and is covered with a smooth bark; the branches are angular, covered with oval leaves, having a strong midrib, and many veins running towards the sides, of a light green color, standing opposite upon very short foot-stalks. From the wings of the leaves the flowers come out upon foot-stalks an inch and a half long: they are composed of five large roundish concave petals, within which are a great number of stamina shorter than the petals, and tipped with pale yellow tops. After the flower is past, the germen becomes a large oval fruit, shaped like a pomegranate. A decoction of the roots of guava is employed with success in dysenteries: a bath of a decoction of the leaves is said to cure the itch and other cutaneous eruptions. Guayava, or guava, is distinguished from the color of the pulp into the two species above-mentioned, the white and the red; and, from the figure of the fruit, into the round and the pear-fashioned or perfumed guava. The latter has a thicker rind, and a more delicate taste than the other. The fruit is about the bigness of a large tennis ball; the rind or skin generally of a russet stained with red. The pulp within the thick rind is of an agreeable flavor, and interspersed with a number of small white seeds. The rind, when stewed, is eaten with milk, and preferred to any other stewed fruit. From the same part is made marmalade; and from the whole fruit is prepared the finest jelly in the world. The fruit is very astringent, and nearly of the same quality with the pomegranate; so should be avoided by all who are subject to costiveness. The seeds are so hard as not to be affected by the fermentation in the stomachs of animals; so that when voided with the excrements they take root, germinate, and produce thriving trees. Whole meadows in the West Indies are covered with guavas which have been propagated in this manner. The buds of guava, boiled with barley and liquorice, produce an excellent pisan for diarrhœas, and even the bloody flux, when not too inveterate. The wood of the tree, employed as fuel, makes a lively, ardent, and lasting fire.

PSITTACUS, the parrot, in ornithology, a genus belonging to the order *picæ*. The bill is hooked from the base; the upper mandible is moveable: the nostrils are round, placed in the base of the bill, which in some species is furnished with a kind of cere: the tongue is broad, and blunt at one end: the head is large, and the crown flat: the legs are short, the toes placed two before and two behind. It might seem surprising why this animal, which is not naturally a bird of prey, but feeds on fruits and vegetables, should have the crooked beak allotted to the hawk and other carnivorous birds: the reason seems to be that the parrot being a heavy bird, and its legs not very fit for service, it climbs up and down trees by the help of this sharp and hooked bill, with which it lays hold of any thing and secures itself before it stirs a foot; and helps itself forward very much, by pulling its body on with this hold. Of all animals, the parrot and crocodile are the only ones which move the upper jaw; all creatures else moving the lower only. The parrot loves nothing so much as the seeds of the carthamus, or bastard saffron. Parrots

are found almost every where within the tropics; and in their natural state they live on fruits and seeds, though, when tame, they will eat flesh, and even fish. In the East and West Indies they are very common, and in such warm climates are very brisk and lively; here, however, they lose much of their vigor. They seldom make nests, but breed like owls in hollow trees: they lay two eggs. At particular times they fly in very large troops, but still they keep two and two together. This genus consists of infinite variety, not so much owing to mixture of species. Mr. Latham increased the genus from forty-seven to 163; and, since the time he wrote his Index, at least thirty more have been discovered. They are very generally divided into three kinds: 1. The larger, which are as big as a moderate fowl, called macaos and cocketoons; these have very long tails. 2. The middle-sized ones, commonly called parrots, which have short tails, and are a little larger than a pigeon. And, 3. The small ones, which are called paroquets, and have long tails, and are not larger than a lark or blackbird.

1. *P. ararauna*, the blue and yellow macaw, is blue above, and yellow below, and the cheeks are naked, with feathery lines. It is about the same size with the last, and inhabits Jamaica, Guiana, Brasil, and Surinam.

2. *P. aurora*, the yellow amazon, is about twelve inches long, of a green color, with blue wing quills, and a white front; its orbits are snowy. It inhabits Mexico or Brasil, but in all probability the latter, from the one which Salerne saw, and which pronounced Portuguese words.

3. *P. Guineensis*, the yellow lory, is about ten inches long, and is an inhabitant of Guinea. The bill is of a black color; the cere, the throat, and space about the eyes, are white; above the eye there is a patch of yellow, and the rest of the head and neck is crimson. The breast is yellow, wing coverts green, and the quills are blue, edged with yellow. Under the wings, belly, thighs, vent, and to the under part of the tail, the color is white, which last is tipped with red; the legs are dusky, and the claws black.

4. *P. macao*, the red and blue macao, is red, except the wing quills, which above are blue, below red: the particular feathers are variegated with blue and green: the cheeks are naked and wrinkled. It is about two feet seven inches and a half long, and about the size of a capon. It inhabits Brasil, Guiana, and other parts of South America. It was formerly very common in St. Domingo, but is now rarely found there. It generally lives in moist woods. does not in general learn to speak, and its voice is particularly rough and disagreeable. The flesh is hard, black, and unsavory, but makes good soup, and is much used by the inhabitants of Cayenne and other places. This species, in common with other parrots, is subject to fits when tamed.

5. *P. pullarius*, red-headed Guinea paroquet, or Guinea sparrow, is about five inches and a half long. It inhabits Guinea, and is found in Ethiopia, the East Indies, and the island of Java, and sometimes in Surinam. It is green, with a red front, fulvous tail, black bar, and

cinereous orbits. The male of this species is peculiarly affectionate to the female.

6. *P. severus*, the Brazilian green macaw, is black, with a greenish splendor: the bill and eyes are reddish, and the legs are yellow. It is about one foot and five inches long, and is common in Jamaica, Guiana, and Brasil. It is, however, comparatively rare; but is extremely beautiful, and of a very amiable and sociable temper when familiar and acquainted; but it can neither bear strangers nor rivals; its voice is not strong, nor does it articulate very distinctly the word ara.

PSOAS MUSCLE, in anatomy. See ANATOMY.

PSOKV, a government of European Russia, between those of Livonia and Smolensko. Its superficial extent is about 22,000 square miles; and the population about 700,000, almost all of Russ origin, and members of the Greek church. It is divided into eight circles or districts. The surface is level, and clayey or sandy, but tolerably fertile, producing flax and hemp, which, along with the timber of its forests, are exported to Narva and St. Petersburg. The manufactures are limited to the weaving of linen, and the preparation of leather. The climate is healthy, but cold. Pskov is watered by several rivers, and contains a large lake called the lake of Pskov.

Pskov, or PLESKOV, a considerable trading town and archbishop's see of European Russia, the capital of the above government, is situated at the confluence of the Pskov River and the Velikaja. It is small, but contains a kremlin or citadel; a middle town and greater town; all distinct and surrounded by an earthen mound. Inhabitants 7000. Leather is the only manufacture.

PSOPHIA, in ornithology, a genus belonging to the order of gallinæ. The bill is moderate; the upper mandible convex; the nostrils oblong, sunk, and pervious; the tongue cartilaginous, flat, and fringed at the end; and the legs are naked a little above the knees. The toes are three before and one behind; the last of which is small with a round protuberance beneath it, which is at a little distance from the ground. Latham only enumerates two species.

1. *P. crepitans*, the gold-breasted trumpeter. Its head and breast are smooth and shining green. By the Spaniards of Maynas it is called trompetero, and by the French at Cayenne agami, under which last Buffon describes it. It inhabits various parts of South America, Brasil, Guiana, Surinam, &c., but it is most plentiful in the Amazons country. It is about twenty inches long, being about the size of a large fowl, and lays eggs rather larger, of a blue green color. It is met with in the Caribee islands, where it is called a pheasant, and its flesh is reckoned as good as that of a pheasant. The most characteristic and remarkable property of these birds consists in the wonderful noise they make, particularly when urged by the keepers of the menagerie. Another very remarkable circumstance is, that they follow people through the streets, though perfect strangers. It is difficult to get rid of them; for, if you enter a house, they will wait your return, and again join you,

though often after an interval of three hours. 'I have sometimes,' says M. de la Borde, 'be-taken myself to my heels, but they ran faster, and always got before me; and, when I stopped, they stopped also. I know one,' continues he, 'which invariably follows all the strangers who enter his master's house, accompanies them into the garden, takes as many turns as they do, and attends them back again.'

2. *P. undulata*, the undulated trumpeter, is about the size of a goose. The upper part of the body is of a pale reddish brown color, beautifully undulated with black. The head is adorned with a dependent crest. On each side of the neck, beneath the ears, begins a list of black, widening as it descends, and meeting on the lower part before, where the feathers become greatly elongated, and hang loosely down. The under parts are generally white, the legs are of a dusky blue color like the bill. It is a native of Africa; Latham's specimen came from Tripoli.

**PSORALEA**, in botany, a genus of the decandria order, and diadelphia class of plants; natural order thirty-second, papilionaceæ: *CAL.* powdered, with callous points, and as long as the monospermous legumen. The most remarkable species are:—

1. *P. aculeata*, the aculeated prickly psoralea, which rises with a shrubby branching stem three or four feet high, with ternate leaves, having wedge-shaped lobes terminating in a recurved sharp point, and the branches terminated by roundish heads of blue flowers; it grows in Ethiopia. These plants flower here every summer; the first sort greatest part of that season, and the others in July and August; all of which are succeeded by seeds in autumn. Keep them in pots in order for removing into the greenhouse in winter. They are propagated by seeds, sown in a hot-bed in the spring; and, when the plants are two or three inches high, prick them in separate small pots, and gradually harden them to the open air, so as to bear it fully by the end of May or beginning of June. They may also be propagated by cuttings any time in summer, planted in pots, and plunged in a little heat, or covered close with hand-glasses, shaded from the sun and watered.

2. *P. bituminosa*, the bituminous trifoliate psoralea, rises with a shrubby stalk, branching sparingly about two or three feet high, with ternate or three lobed leaves of bituminous scent, and blue flowers in close heads; it grows in Italy and France.

3. *P. primata*, the pinnated psoralea, rises with a woody soft stem, branching five or six feet high, pinnated leaves of three or four pairs of narrow lobes terminated by an odd one, and at the axillas close-sitting blue flowers with white keels. It is a native of Ethiopia.

**PSYCHE**, a nymph whom Cupid married, and carried into a place of bliss, where he long enjoyed her society. Venus put her to death, because she had robbed the world of her son; but Jupiter, at the request of Cupid, granted immortality to Psyche. The same Greek word, *ψυχη*, signifies a butterfly and the soul. Hence the former was used by the Greek artists as an emblem of the latter; and Cupid fondling or

burning a butterfly is the same as his caressing or paining Psyche or the human spirit. Indeed for almost all the ways in which Cupid is seen playing with butterflies, some parallel may be found in the representations of Cupid and Psyche. Thus, in an antique, the god of love is drawn in a triumphal car by two Psyches; in another by two butterflies. By this might be shadowed forth his power over the beings of the air, of which the car is an emblem.

**PSYCHOTRIA**, in botany, a genus of the monogynia order and pentandria class of plants; natural order forty-seventh, stellatæ: *CAL.* quinque-dentate, persisting, and crowning the fruit: *COR.* tubulated; berry globose, with two hemispherical sulcated seeds. The species are four, viz.:—1. *P. aspatica*. 2. *P. emetica*. 3. *P. herbacea*: and 4. *P. serpens*. They are all natives of Jamaica.

**PSYLLI**, a people in the south of Cyrenaica, so called from king Psyllus (Agathargides, quoted by Pliny); almost all overwhelmed by sand driven by a south wind (Herodotus). According to Pliny, Lucan, &c., they had something in their bodies fatal to serpents, and their very smell proved a charm against them.

**PTARMIGAN**, in ornithology. See **TETRAO**.

**PTELEA**, shrub-trefoil, a genus of the monogynia order and tetrandria class of plants: *COR.* tetrapetalous: *CAL.* quadripartite inferior; fruit monospermous, with a roundish membrane in the middle. There are two species:—

1. *P. trifoliata*, the Carolina shrub trefoil, has a shrubby upright stem, dividing into a branchy head eight or ten feet high, covered with a smooth purplish bark, trifoliate leaves, formed of oval spear-shaped folioles, and the branches terminated by large bunches of greenish-white flowers, succeeded by roundish bordered capsules. This is a hardy deciduous shrub, and a proper plant for the shrubbery and other ornamental plantations to increase the variety. It is propagated by seeds, layers, or cuttings.

2. *P. viscosa*, the viscous Indian ptelea, rises with several strong shrubby stems, branching erectly twelve or fifteen feet high, having a light brown bark, spear-shaped, stiff, simple leaves, and the branches terminated by clusters of greenish flowers. It is a stove plant, and is propagated commonly by seeds.

**PTERIS**, in botany. brakes or female fern, a genus of the order of filices, and cryptogamia class of plants; natural order fifty-fifth, filices. The fructifications are in lines under the margin. There are numerous species; the most remarkable is the

*P. aquilina*, or common female fern. The root of this is viscid, nauseous and bitterish; and, like all the rest of the fern tribe, has a salt, mucilaginous taste. It creeps under the ground in some rich soils to the depth of five or six feet, and is very difficult to be destroyed. Frequent mowings in pasture grounds, plentiful dunging in arable lands, but, above all, pouring urine upon it, are the most approved methods of killing it. It has, however, many good qualities to counterbalance the few bad ones. Fern cut while green, and left to rot upon the ground, is a good improver of land; for its ashes, if burnt,

will yield double the quantity of salt that most other vegetables will. Fern is also an excellent manure for potatoes; for, if buried beneath their roots, it never fails to produce a good crop. Its astringency is so great that it is used in many places abroad, in dressing and preparing kid and chamois leather. In several places in the north the inhabitants mow it green, and, burning it to ashes, make those ashes up into balls, with a little water, which they dry in the sun, and make use of them to wash their linen with instead of soap. In many of the Western Isles the people gain a very considerable profit from the sale of the ashes to soap and glass makers. In Glenelg in Inverness-shire, and other places, the people thatch their houses with the stalks of this fern, and fasten them down with ropes made either of birch-bark or heath. Sometimes they use the whole plant for the same purpose, but that does not make so durable a covering. Swine are fond of the roots, especially if boiled in their wash. In some parts of Normandy the poor have been reduced to the miserable necessity of mixing them with their bread. And in Siberia, and some other northern countries, the inhabitants brew them in their ale, mixing one-third of the roots to two-thirds of malt. The ancients used the root of this fern, and the whole plant, in decoctions, and diet-drinks, in chronic disorders of all kinds, arising from obstructions of the viscera and the spleen. The country people still continue to retain some of its ancient uses; for they give the powder of it to destroy worms, and look upon a bed of the green plant as a sovereign cure for the rickets in children.

**PTEROCARPUS**, in botany, a genus of the decandria order, and diadelphia class of plants; natural order thirty-second, papilionaceæ: *cal.* quinquedentate: *caps.* sulcated, filiceous, varicose. The seeds are few and solitary. There are four species, viz.:-

1. *P. draco*. 2. *P. ecastaphyllum*. 3. *P. lunatus*: and 4. *P. santalinus*. The last is by some referred to the genus *santalum*. It is called red saunders; and the wood is brought from the East Indies in large billets, of a compact texture, a dull red, almost blackish color on the outside, and a deep bright red within. This wood has no manifest smell, and little or no taste. The principal use of red saunders is as a coloring drug; with which intention it is employed in some formulæ, particularly in the compound of tincture of lavender. It communicates a deep red to rectified spirit, but gives no tinge to aqueous liquors; a small quantity of the resin, extracted by means of spirit, tinges a large one of fresh spirit, of an elegant blood-red. There is scarcely any oil, that of lavender excepted, to which it communicates its color.

**PTERONIA**, in botany, a genus of the polygamia æqualis order, and syngenesia class of plants; natural order forty-ninth, compositæ: receptacle full of multipartite bristles; pappus a little plummy: *cal.* imbricated.

**PTEROSPERMUM**, in botany, a genus of the polyandria order and monadelphia class of plants; natural order thirty-seventh, columniferæ: *cal.* quinquepartite: *cor.* consists of five oblong spreading petals. The filaments are about

fifteen, which unite towards the base into a tube. The style cylindrical: *cars.* oval, woody, and quinquelocular, each bivalved, containing many oblong, compressed, and winged seeds. There is only one species, viz.:-

*P. pentapetes*, a native of the East Indies; the wood of which is very hard, and very like that of the holly tree.

**PTINUS**, a genus of insects belonging to the order of coleoptera. The antennæ are filiform: the last or exterior articulations are longer than the others; the thorax is nearly round, without a margin, into which the head is drawn back or received; the feet are made for leaping. The most remarkable species are,-

1. *P. pectinicornis*. This is produced from a worm that lodges in wood and the trunks of trees, such as the willow, where it makes deep round holes, turns to a winged insect, takes flight and roosts upon flowers. It is distinguished by its antennæ pectinated on one side, whence it has the name of feathered. The elytra and thorax are of a deep clay-colored brown, the antennæ and legs are of a pale brown.

2. *P. pertinax*. The form of this insect resembles the preceding one, saving that its antennæ are filiform. It is all over of a deep blackish-brown color resembling soot. It attacks household furniture, clothes, furs, and especially animals dried and preserved in collections of natural history, where it makes great havoc. When caught, this insect bends its legs, draws back its head, and lies as if it was dead till it thinks itself out of danger. It cannot be forced out of this state of inaction either by pricking or tearing; nothing but a strong degree of heat can oblige it to resume its motion and run away. There are many beautiful varieties of this genus; but they in general escape our attention by their minuteness, and living among hay, dried leaves, and divers other dusty matters, where they undergo their metamorphoses. The larvæ of some are found in trunks of decayed trees, in old tables, chairs, &c.

**PTISAN**, *n. s.* *Fr.* *ptisane*; *Gr.* *πιτισανη*. A medical drink, made of barley decocted with raisins and liquorice.

Thrice happy were those golden days of old,  
When dear as burgundy the *ptisans* sold;  
When patients chose to die with better will,  
Than breathe and pay the apothecary's bill. *Garth.*

In fevers the aliments prescribed by Hippocrates were *ptisans* and cream of barley. *Arbuthnot.*

**PTISAN** is properly barley decorticated, or deprived of its husk, by beating in a mortar, as was the ancient practice; though the cooling potion obtained by boiling such barley in water, and afterwards sweetening the liquor with liquorice root, is what at present goes by the name of *ptisan*; and to render it laxative some add a little senna, or other simi ar ingredient.

**PTOLEMAIS**, in ancient geography, the largest and most considerable town of Thebais, or Higher Egypt, and equal to Memphis. It was governed in the manner of a Greek republic, and situated on the west side of the Nile, almost opposite to Coptos. Strabo. This town, which was built by Ptolemy Philadelphus, is now called Ptolometa. The walls and gates

are still entire, and there are a vast number of Greek inscriptions, but only a few columns of the portico remain. There is likewise an Ionic temple, in the most ancient style of executing that order, of which Mr. Bruce took a drawing, which is preserved in the king's collection.

PTOLEMAIS, the port of Arsinoë, situated on the west branch of the Nile, which concurs to form the island called Nomos Hieracleotes, to the south of the vertex of the Delta.

PTOLEMY (Claudius), a celebrated mathematician and astrologer, born at Pelusium, and surnamed by the Greeks most divine and most wise. He flourished at Alexandria in the second century, under Adrian and Marcus Aurelius, about A. D. 138. There are still extant his Geography, and several learned works on astronomy. The principal of which are 1. The Almagest. 2. De Judiciis Astrologicis. 3. Planisphærium. His system of the world was for many centuries adopted by the philosophers and astronomers. See ASTRONOMY.

PTOLEMY, a son of Pyrrhus, king of Epirus, by Antigone, who was left governor of Epirus, while his father was absent in Italy, fighting against the Romans. He governed with great prudence, and was killed some time after in Pyrrhus's expedition against Sparta and Argos.

PTOLEMY CERAUNUS, the eldest brother of Ptolemy Philadelphus, who fled to Seleucus king of Macedonia, who received him hospitably; in return for which he assassinated him, and usurped his crown. He then invited Arsinoë, who was his widow and his own sister, to share the government with him; but, as soon as he had her in his power, he murdered her and her children. He was at length defeated, killed, and torn limb from limb by the Gauls, A. A. C. 279.

PTOLEMY LAGUS, or SOTER, king of Egypt, a renowned warrior, who established the academy at Alexandria. He was the first of the Macedonian race of Egyptian monarchs, being a natural son of Philip II. of Macedon, by Arsinoë, who married Lagus while she was pregnant of him. He was one of Alexander's generals, and killed an Indian king in single combat; and to his courage Alexander owed the reduction of Aornos. He conquered Cælosyria, Phœnicia, and part of Syria, and carried 100,000 prisoners to Egypt, whom he attached to him by liberal privileges. He wrote a History of Alexander, which was much admired, but is lost. He died A. A. C. 284, aged ninety-two.

PTOLEMY PHILADELPHUS, the second son of Ptolemy Soter. He was renowned as a conqueror, but more revered for his great virtues and political abilities. He established and augmented the famous Alexandrian library, which had been begun by his father. He greatly increased the commerce of Egypt, and granted considerable privileges to the Jews, from whom he obtained a copy of the Old Testament, which he caused to be translated into Greek, and deposited in his library. See SEPTUAGINT. He died 246 years B. C. aged sixty-four.

Ptolemy was also the name of eleven other kings of Egypt, of whose reigns we here only add the following brief chronological table, down to queen Cleopatra, the last of the race:—

	Years.	A. M.
1. Ptolemy Soter reigned	39	and died 3720
2. Ptolemy Philadelphus	39	3758
3. Ptolemy Euergetes	25	3783
4. Ptolemy Philopater	17	3800
5. Ptolemy Epiphanes	24	3824
6. Ptolemy Philometor	37	3861
7. Ptolemy Physcon	28	3888
8. Ptolemy Lathyrus	36½	3923
9. Ptolemy Alexander I.	20	3943
10. Ptolemy Alexander II.	6	3949
11. Ptolemy Alexander III.	1	banished.
12. Ptolemy Auletes	13	3953
13. Ptolemy Dionysius	3½	3953
14. Cleopatra	17	3974

PUBERTY, *n. s.* } Fr. *puberté*; Lat. *pubescentia*, }  
 PUBESCENCE, } *bertas*. The time of life  
 PUBESCENT, *adj.* } in which the two sexes be-  
 gin to be acquainted: pubescence is the state of  
 puberty: pubescent, the corresponding adjective.

The cause of changing the voice at the years of *puberty* seemeth to be, for that when much of the moisture of the body, which did before irrigate the parts, is drawn down to the spermatical vessels, it leaveth the body more hot than it was, whence cometh the dilatation of the pipes. Bacon.

Solon divided it into ten septenaries: in the first is dedentition or falling of teeth, in the second *pubescence*. Browne.

That the women are menstruant, and the men *pubescent* at the year of twice seven, is accounted a punctual truth. Id.

All the carnivorous animals would have multiplied exceedingly, before these children that escaped could come to the age of *puberty*. Bentley's Sermons.

PUBERTY, in law, is fixed at the age of twelve in females, and fourteen in males; after which they are reckoned to be fit for marriage.

PUBES, in botany, the hair or down on the leaves of some plants. See HAIR.

PUBES, in anatomy. See ANATOMY.

PUBLIC, *adj. & n. s.* } Fr. *publicque*; Ital.  
 PUBLICAN, *n. s.* } and Span. *publico*;  
 PUBLICATION, } Port. *pubrico*; Lat.  
 PUBLIC-HOUSE, } *publico, publicus*. Ge-  
 PUBLICLY, *adv.* } neral; universal;  
 PUBLICNESS, *n. s.* } open: belonging to  
 PUBLIC-SPIR'ITED, *adj.* } a state or nation;  
 PUBLISH, *v. a.* } open: the great body  
 PUBLISHER, *n. s.* } of a, people or of

mankind; open view or notice; exposure: publicly and publicness corresponding: publican is, in an ancient sense, a toll or tax-gatherer; in a modern one, the landlord of a house of public entertainment, or public-house: publication is the act of publishing a thing, particularly a book published; also an edition of a book: public-spirited is, having regard to the general good; patriotic: to publish is, to make generally known; make public; proclaim; send forth a book into the world: publisher, follows both the general and particular sense.

As Jesus sat at meat, many *publicans* and sinners came and sat down with him. Matt. ix. 10.

Joseph being a just man, and not willing to make her a *public* example, was minded to put her away privily. Matthew.

By following the law of private reason, where the law of *public* should take place they breed disturbance. Hooker.

For the instruction of all men to eternal life, it is necessary that the sacred and saving truth of God be openly *published* unto them, which open *publication* of heavenly mysteries is by an excellency termed preaching.

How will this grieve you,  
When you shall come to clearer knowledge, that  
You thus have *published* me! *Shakspeare.*

Love of you  
Hath made me *publisher* of this pretence. *Id.*  
Sometimes also it may be private, communicating to the judges some things not fit to be *publicly* delivered.

And for traducing such  
That are above us, *publishing* to the world  
Their secret crimes, we are as innocent  
As such as are born dumb. *Massenger.*  
His commission from God and his doctrine tend to the impressing the necessity of that reformation which he came to *publish*. *Hammond.*

If I had not unwarily too far engaged myself for the present *publishing* it, I should have kept it by me.

They were *public* hearted men; as they paid all taxes, so they gave up all their time to their country's service, without any reward. *Clarendon.*

A dismal universal hiss, the sound  
Of *public* scorn. *Milton.*

Suppose he should relent,  
And *publish* grace to all. *Id.*  
Of royal maids how wretched is the fate,  
Born only to be victims of the state;  
Our hopes, our wishes, all our passions tried  
For *public* use, the slaves of others pride.

The multitude of partners does detract nothing from each private share, nor does the *publicness* of it lessen propriety in it. *Boyle.*

The apostle doth not speak as the *publisher* of a new law, but only as a teacher and monitor of what his lord and master had taught before. *Kettlewell.*

These were the *public spirited* men of their age, that is, patriots of their own interest. *Dryden.*  
Philosophy, though it likes not a gaudy dress, yet, when it appears in *public*, must have so much complacency as to be clothed in the ordinary fashion.

They have with bitter clamours defaced the *public* service of our church. *White.*

I am called off from *public* dissertations by a domestic affair of great importance, which is no less than the disposal of my sister Jenny for life.

Those nations are most liable to be over-run and conquered, where the people are rich, and where, for want of good conduct, the *public* is poor. *Davenant.*

All nations that grew great out of little or nothing, did so merely by the *public* mindedness of particular persons. *South.*

The *public* is more disposed to censure than to praise. *Addison.*

The income of the commonwealth is raised on such as have money to spend at taverns and *public-houses*. *Id.*

This has been so sensibly known by trading nations, that great rewards are *publicly* offered for its supply. *Id.*

Another *public-spirited* project, which the common enemy could not foresee, might set king Charles on the throne. *Id.*

The unwearied sun, from day to day,  
Does his Creator's power display,  
And *publishes* to every land  
The work of an almighty hand. *Id. Spectator.*  
A collection of poems appeared, in which the *pub-*

*lisher* has given me some things that did not belong to me. *Prior.*

A good magistrate must be endued with a *public* spirit, that is, with such an excellent temper as sets him loose from all selfish views, and makes him endeavour towards promoting the common good.

In *public* 'tis they hide,  
Where none distinguish. *Pope.*

An imperfect copy having been offered to a bookseller, you consented to the *publication* of one more correct. *Id.*

The *publication* of these papers was not owing to our folly, but that of others. *Swift.*

Have we not able counsellors hourly watching over the *public* weal? *Id.*

It was generous and *public-spirited* in you to be of the kingdom's side in this dispute, by shewing, without reserve, your disapprobation of Wood's design. *Id.*

Then each, in its peculiar honours clad,  
Shall *publish* even to the distant eye  
Its family and tribe. *Cowper.*

PUBLIUS, a prænomen very common among the ancient Romans. It was the prænomen of the Scipios, Ovid, and many other eminent men.

PUCERON, in entomology, a common name given to several genera of animalcules or insects, most of which live on the young branches of trees, particularly the peach tree, and feed on the sap. The various genera and species of pucerons have each their favorite plant, on which they live and feed on its juices.

Earth pucerons differ from most of the other genera, by residing in the earth. In the month of March, if the turf be raised in several places in any dry pasture, there will be found, under some parts of it, clusters of ants; and, on a farther search, it will be usually found that these ants are gathered about some pucerons of a peculiar species. These pucerons are large, and of a grayish color, and are usually found in the midst of clusters of ants. As the common abode of the other kinds of puceron is on the young branches or leaves of trees, and as their only food is the sap of these trees, these earth kinds are supposed to extract their food from the roots of grasses, and other plants, in the same manner that the others do from the leaves and branches. The ants follow these and the other species, for the sake of the saccharine juices which they extract from plants, and which they evacuate very little altered from their original state in the vegetable.

Oak pucerons, a name given by naturalists to a very remarkable species of animal of the puceron kind. They bury themselves in the clefts of the oak and some other trees, and get into the crevices, where the bark is a little separated from the wood. They are larger than the other pucerons, the winged ones being nearly as large as a common house fly; those without wings are also larger than any other species of the same genus. The winged ones are black, and the others of a coffee color. Their trunk is twice the length of their bodies, and, when walking, it is carried straight along the belly, trailing behind it with the point up. When the puceron wishes to suck a part of a tree that is just before it, it draws up, and shortens the trunk, till it brings

it to a proper length and direction; but, when it sucks in the common way, it crawls upon the inner surface of the bark, and the turned up end of the trunk, which resembles a tail, fixes itself against the wood that is behind it, and sucks there. The extremity of this trunk holds so fast by the wood, that, when it is pulled away, it frequently brings a small piece of the wood away with it. The ants are as fond of these as of the other species of pucerons, not feeding upon them, but on their dung, which is a liquid matter of a sweet taste. These creatures are the surest guides where to find this species of puceron; for, if we at any time see a number of these crawling up an oak and creeping into the clefts of the bark, we may be assured that in that place there are quantities of these oak pucerons. The ants are so extremely fond of the juices of the tree, when prepared by passing through the body of this animal, that when the puceron has a drop not yet evacuated, but hanging only in part out at the passage, an ant will often seize on it there.

**PUCK', n. s.** } Scot. *puck*; Goth. *puke*. A **PUCK'ER.** } sprite among the fairies; an imp, who seems chargeable with mischievous disarrangements of ladies' work, dress, &c.: hence pucker, a disorderly fold: or from *POKE*, a bag, which see.

O gentle *puck*, take this transformed scalp  
From off the head of this Athenian swain.  
*Shakespeare.*

Turn your cloaks,  
Quoth he, for *puck* is busy in these oaks,  
And this is fairy ground. *Corbet.*  
I saw an hideous spectre; his eyes were sunk into  
his head, his face pale and withered, and his skin  
*puckered* up in wrinkles. *Spectator.*  
A ligature above the part wounded is pernicious,  
as it *puckers* up the intestines and disorders its situation. *Sturp.*

**PUCKHOLI**, or **PAXALI**, a district to the north of the province of Lahore, situated about 34° of N. lat., and bounded on the west by the Indus. It is very little known beyond the description given of it in the sixteenth century by Abul Fazel. The common but hazardous road from Cashmere to the Indus lies through this district, which is chiefly held by predatory Afghaun tribes.

**PUD'DER**, *n. s., v. n., & v. a.* Commonly written **POTHER**, which see. A tumult; turbulent and irregular bustle: to make such a bustle: to perplex; confound.

Let the great gods,  
That keep this dreadful *pudder* o'er our heads,  
Find out their enemies. *Shakespeare. King Lear.*  
What a *pudder* is made about essences, and how much is all knowledge pestered by the careless use of words! *Locke.*  
Mathematicians, abstracting their thoughts from names, and setting before their minds the ideas themselves, have avoided a great part of that perplexity, *puddering* and confusion, which has so much hindered knowledge. *Id.*  
He that will improve every matter of fact into a maxim will abound in contrary observations, that can be of no other use but to perplex and *pudder* him. *Id.*

VOL. XVIII.

**PUD'DING**, *n. s.* } Fr. *boudin*; Welsh *pot-*  
**PUD'DINGPIES,** } *ten* (an intestine) Swed.  
**PUD'DINGTIME,** } *pudding*; Span. *puddin*. A kind of food variously compounded, but made commonly of meal and suitable admixtures: it seems to owe its name to being originally cooked in the integuments of animals: a pudding pie is a pudding containing meat: pudding time, dinner time: hence, by a construction natural enough, any critical time.

He'll yield the crow a *pudding* one of these days;  
The king has killed his heart. *Shakespeare. Henry V.*  
As sure as his guts are made of *puddings*.  
*Shakespeare.*

Some cry the covenant, instead  
Of *puddingpies* and gingerbread. *Hudibras.*  
Mars that still protects the stout,  
In *puddingtime* came to his aid. *Id.*  
Sallads, and eggs, and lighter fare  
Tune the Italian spark's guitar;  
And, if I take Dan Congreve right,  
*Pudding* and beef make Britons fight. *Prior.*  
Mind neither good nor bad, nor right nor wrong,  
But eat your *pudding*, slave, and hold your tongue.  
*Prior.*

**PUD'DLE**, *n. s. & v. a.* } Latin *puteolus*.  
**PUD'DLY**, *adv.* } Skinner; from old Bavarian *poil*, dirt, Junius; Ital. *padula*. A small muddy lake; a dirty plash: to plash; be mired; the adverb corresponding.

As if I saw my sun-shine in a *puddled* water, I  
cried out of nothing but Mopsa. *Sidney.*  
Thou didst drink  
The stale of horses, and the gilded *puddle*  
Which beasts would cough at. *Shakespeare.*  
His beard they singed off with brand of fire,  
And, ever as it blazed, they threw on him  
Great pails of *puddled* mire to quench the hair. *Id.*  
Limy, or thick *puddly* water killeth them.  
*Carew.*

The Hebrews drink of the well-head, the Greeks  
of the stream, and the Latins of the *puddle*. *Hall.*  
Treading where the treacherous *puddle* lay,  
His heels flew up; and on the grassy floor  
He fell, besmeared with filth. *Dryden's Virgil.*  
The noblest blood of Africk  
Runs in my veins, a purer stream than thine;  
For, though derived from the same source, thy current  
Is *puddled* and defiled with tyranny. *Dryden.*

A physician cured madmen thus: they were tied  
to a stake, and then set in a *puddle*, till brought to  
their wits. *L'Estrange.*  
Happy was the man, who was sent on an errand  
to the most remote street, which he performed with  
the greatest alacrity, ran through every *puddle*, and  
took care to return covered with dirt. *Addison.*

**PUD'DENCY**, *n. s.* Lat. *puđens*. Modesty; shamefacedness.  
A *puđency* so rosy, the sweet view on't  
Might well have warm'd old Saturn.  
*Shakespeare.*

**PUEBLA**, or **PUEBLA DE LOS ANGELOS** (because, as we shall see, the angels were materially concerned in the erection of the capital), is one of the twelve intendencies into which Mexico or the former 'New Spain' is divided. It has a coast of about seventy-eight miles towards the Pacific; and, as it extends from 16° 57' to 20° 40' of N. lat., is wholly situated within the tropics. It is bounded on the north-east by Vera

R



Cruz, on the east by the intendency of Oaxaca, on the south by the Ocean, and on the west by Mexico. Its greatest length from the mouth of the small river Tecoyame to near Mexitlan is 118 leagues, and its greatest breadth from Techuacan to Mecameca is 150 miles. The greater part of this province is traversed by the high cordilleras of Anahuac. Beyond 18° of latitude the whole country is a plain, eminently fertile in wheat, maize, agave, and fruits, and from 5900 to 6560 feet above the level of the sea. Here is the most elevated mountain of New Spain, the Popocatepetl. The volcano, first measured by Humboldt, is continually burning; but for these several centuries it has thrown nothing up from its crater but smoke and ashes. It is nearly 2000 feet higher than the most elevated summit of the old continent; and there is only one higher mountain in the American continent. The population is unequally distributed, being concentrated on the plain which extends from the eastern declivity of the snowy Andes to the environs of Perote, especially between Cholula, La Puebla, and Tlascala. Almost the whole country, from the central table-land towards San Luis and Yguapala, near the South Sea coast, is desert; but not ill adapted for sugar, cotton, and other productions of the tropics. The table-land of La Puebla exhibits vestiges of ancient Mexican civilisation. The great pyramid of Cholula is a curious monument.

'We left La Puebla on the 22d of March, and slept at San Martin,' says Mr. Ward, the latest traveller in these regions, 'taking the road through Cholula to that place, in order to obtain a better view of the old Mexican Teocalli, or pyramid, of which Humboldt's work contains so detailed a description. The base of this pyramid comprises a square of about 1773 feet; the height is fifty-four metres, or 177 feet. It is truncated, and, on the spacious platform in which it terminates, the conquerors have erected a chapel as if to mark the substitution of another creed, and another race, for the nation by whose united exertions this stupendous monument must have been raised. The whole mass is formed of alternate layers of unburnt bricks and clay, and is now overgrown with thick shrubs, amongst which clouds of tortolas (a small wood pigeon) are found. Its structure is said by baron Humboldt to present a curious analogy with that of the temple of Belus at Babylon, and of the pyramids of Egypt. Its object was undoubtedly religious, but as its construction is ascribed to the Toltecs, a nation which preceded the Aztecs in their emigration towards the south, the exact nature of the rites to which it was dedicated can only be conjectured. It may have served for the performance of human sacrifices in the sight of the assembled tribe; or as a place of defence in the event of an unexpected attack:—perhaps the two objects were combined, for, in the siege of Mexico, the most obstinate resistance was made in the vicinity of the great temple (which resembled in form, though not in size, the Teocalls of Cholula and Teotihuacan), from the summit of which the priests are said to have encouraged the war-

riors by whom the great staircase and platform were defended.

'The view from the pyramid of Cholula embraces the three great volcanoes, and the Malinche, with a finely cultivated country covering the intervening space. The town of Cholula lies immediately below the platform, reduced, like the rival state of Tlascala, which is separated from it by the Malinche, to a mere shadow of its former greatness; but still indicating, by the size of its plaza, the extent of ground which the city formerly covered. The fertility of the plain around is very great, as from the vicinity of the two great mountains, Popocatepetl and Istacchuatl, a constant supply of water for irrigation can be obtained; it abounds in haciendas de trigo (corn estates), many of which, in good years, are said to produce wheat in the proportion of eighty to one to the seed. This fertility terminates a little beyond San Martin, where the passage of the mountains, that separate La Puebla from Mexico, commences.'

The progress of commerce has in this province been extremely slow. The flour trade, formerly very flourishing, has suffered from the enormous price of carriage from the Mexican table-land to the Havannah, and especially from the want of beasts of burden. That which Puebla carried on till 1710 with Peru, in hats and delf-ware, has entirely ceased. The intendency has considerable salt-works near Chila, Xicotlan, and Ocotlan, in the district of Chiautla, as also near Zapotitlan. The beautiful marble known by the name of the Puebla marble is procured in the quarries of Totamehuacan and Tecali, at two and seven leagues distance from the capital. The indigenous inhabitants speak three languages, very different from each other, i. e. the Mexican, Totonac, and Tlapanec. Their industry is not much directed to the working of the mines, many of which are either abandoned or very partially worked. The population of Puebla was estimated, in 1803, at 813,300 inhabitants. The extent of surface is 2696 square leagues, which allows 301 inhabitants to each square league.

PUEBLA, LA, DE LOS ANGELOS, a city of Mexico, the capital of the intendency of this name, is one of the number of American towns founded by European colonists; for, in the plain of Acaxete or Cuiltaxcoapan, on the spot where this capital now stands, there were only, in the beginning of the sixteenth century, a few huts inhabited by the Indians of Cholula. The privilege of the town of Puebla is dated 28th September, 1531.

La Puebla stands on a plain 7381 feet above the level of the sea, and is, after Mexico, Guanajuato, and the Havannah, the most considerable city of the former Spanish colonies. Its temples are sumptuous; and its streets wide, and drawn in a straight line from east to west, and from north to south. The public squares are large and handsome, and the edifices in a suitable style of architecture. The principal square is adorned on three sides with uniform porticoes, and shops filled with all kinds of commodities; on the other is the cathedral, which has a very beautiful front, and two lofty towers.

'We remained,' says Mr. Ward, 'during the

whole of the 22d at La Puebla, as the governor, whose hospitality and friendly disposition towards every Englishman of respectability who visits the town I have ever found the same, would not hear of our passing a shorter time with him than we had done at Jalapa with general Barragan. The delay afforded us an opportunity of seeing the cathedral, a magnificent building, in the construction of which *the angels themselves* are said to have taken a very active part. It is regarded by the Indians, and by a large proportion of the female Spanish population, as a well authenticated fact, that, during the time that the walls of the edifice were constructing, two messengers from heaven descended every night, and added to their height exactly as much as had been raised, by the united efforts of the laborers, during the day. With such assistance the work advanced at a prodigious rate, and was brought to a conclusion in a much shorter space of time than could have been effected by human exertions alone. It is in grateful commemoration of this event that the name of the town, 'La Puebla de los Angeles,' was assumed; and as all the details of it are recorded with singular care in the convents, which have since been built upon this favored spot, there is little danger of their not being handed down to posterity, in all the purity in which they are now preserved.

But, whether of divine or human origin, the cathedral is a very fine building, and the riches of the interior are worthy of a country that has produced, during the last two centuries, nearly two-thirds of the whole of the silver raised annually in the world. The lofty candlesticks, the balustrade, the lamps, and all the ornaments of the principal altar, are of massy silver; and the effect produced by such magnificence, in conjunction with the beauty of the columns of native marble by which the roof is supported, is very striking. We were not, however, allowed to admire them long in peace, for, notwithstanding the presence of M dame Calderon, and two or three aides-de-camp of the governor, the curiosity excited by the first appearance of an English woman was so ungovernable that the great market-place, through which the carriage had passed, transferred in a moment by far the largest portion of its inmates to the cathedral, where the crowd soon became so great that, although no incivility was intended, it was quite impossible for us to remain. La Puebla contained, at that time, a Lazzaroni population nearly as numerous as that of the capital; a naked and offensive race, whom you cannot approach without pollution, or even behold without disgust. I do not know any thing in nature more hideous than an old Indian woman, with all the deformities of her person displayed, as they usually are, by a dress which hardly covers a tenth part of her body; and in La Puebla, in consequence of the numerous convents in which alms were distributed, these objects were particularly numerous. We were too happy to escape by a different door from that by which we had entered, and to take refuge in the carriage.

Besides the cathedral, there are other churches

and convents, well built and adorned. There are also several colleges and charity schools, both for male and female pupils. Puebla was formerly celebrated for its fine manufactories of delf-ware and pots. At present the delf manufactories have declined, on account of the low price of the stone-ware and porcelain imported at Vera Cruz. Hard soap is still a considerable manufacture and object of commerce: it is also famous for its manufactures of iron and steel, particularly swords and bayonets.

Mr. Ward says 'La Puebla was formerly a town inferior only to the capital in extent and population. It contains at present about 50,000 inhabitants, and is an important place, as being the seat both of the richest bishopric in the country, and of the most extensive manufactures of cotton, earthenware, and wool. The streets, like those of Mexico, are rectangular, spacious, and airy. The houses low, but roomy, and the apartments mostly paved with porcelain, and adorned with Fresco paintings on the stuccoed walls. The country around is rich, but naked, being totally devoid of trees, with the exception of the Pinal, a pine forest (as the name implies), which extends from within a league and a half of Nopaluca, to about five leagues from the gates of La Puebla, where cultivation re-commences. The whole distance is about twelve leagues. The road through the Pinal is extremely bad, and dangerous in unsettled times, the forest being the favorite haunt of banditti, who sometimes assemble there in considerable numbers for a coup de main.' Seventy miles E. S. E. of Mexico, and 150 W. N. W. of Vera Cruz. Inhabitants 67,800.

PUENTE DEL ARÇOBISPO, or ARCHBISHOP'S BRIDGE, a town in the west of Spain, on the Tagus, fifty-eight miles W. S. W. of Toledo. Population 1200. The name is derived from an old bridge over the river.

PUENTE DE DON GONZALO, a town of Cordova, Spain, belonging in part to the duke of Medina Celi. Population 4800. Fifteen miles west of Lucena.

PU'ERILE, *adj.* } Fr. *puerile*; Lat. *puer-*  
PUERIL'ITY, *n. s.* } *lis*. Childish; boyish: state or time of boyhood; childishness.

A reserve of *puerility* not shaken off from school.

*Broune.*

Some men, imagining themselves possessed with a divine fury, often fall into toys and trifles, which are only *puerilities*.

*Dryden.*

I looked upon the mansion with a veneration mixed with a pleasure that represented her to me in those *puerile* amusements.

*Pope.*

PUERPERAL FEVER. See MIDWIFERY.

PUERTO DEL BAYLIO BUCARELI, a bay on the west coast of the Prince of Wales's archipelago, discovered by Quadra in 1775, and containing a great number of small islands. Long. 226° 12' to 227° 5' E., lat. 55° 14' to 55° 40' N.

PUERTO DE BAZAN, a bay on the south-west coast, of the above archipelago. Long. 227° 16' E., lat. 54° 49' N.

PUERTO CORDOVA, a bay on the east coast of Prince William's Sound, between Hawkins's Island and the north-west coast of America. Long. 214° 13' E., lat. 60° 37' N.

PUERTO CORDOVA Y CORDOVA, a large bay of the North Pacific, on the south side of the Prince of Wales's archipelago. Long. 227° 28' to 228° E., lat. 54° 42' to 55° 6' N.

PUERTO GRAVINA, an inlet on the north-western coast of America, in Prince William's Sound. For four miles it runs parallel to the neighbouring inlet of Port Hidalgo, and the intervening land is not more than four miles across. It then suddenly turns to the N. N. E. for about four miles and a half, when it terminates in a shallow flat in long. 214° 45' E., lat. 60° 44' N. At its entrance it is from four to six miles wide.

PUERTO REAL, an increasing town in the south-west of Spain, in Seville, five miles east of Cadiz, on the bay. The streets are airy, clean, and straight. At the beginning of last century it had not more than 1500 inhabitants: it now contains more than 10,000. This is the great depot of the salt made in the tanks that of the isle of Leon and bay of Cadiz.

PUERTO DE SANTA MARIA, or ST. MARY'S, the Portus Menesthei of the ancients, a sea-port of Spain, in Seville, five miles north-east of Cadiz, at the mouth of the Guadalete. The climate is excellent, having little either of the severity of cold in winter, or the scorching heat of summer, and the town is well built, well paved, and kept very clean. The Calle Ancha is about a mile in length, and resembles a superior English street in the number of shops and bustle. On the west side of the town there is a very fine prospect of the bay and town of Cadiz, and the surrounding country. The church and monasteries are chiefly remarkable for a profusion of ornaments. The public walk is fine; and there is a beautiful public garden on the bank of the Guadalete. The quay is also well contrived, but large ships cannot come up, on account of sand-banks at the mouth of the river. The only manufacture of consequence is linen and printed cotton, but the inhabitants are still more in preparing the bay-salt of the adjoining salt-pans. There is also a traffic in the conveyance of water from one of the fountains to Cadiz, for the supply of the town and ships. St. Mary's is the residence of the captain-general and vicar-general of Andalusia, and of an official of the archbishop of Castile. Inhabitants 12,000.

PU'ET, *n. s.*, or PEW'ET, which see. A kind of water fowl.

Among the first sort are coots, sanderlings and *puets*. *Carew.*

The fish have enemies enough; as otters, the cornorant, and the *puet*. *Walton's Angler.*

PUFF, *n. s.*, *v. n.* & *v. a.* } Belg. *poef*; Span. *PUFFINGLY*, *adv.* } *poufo, bifo*; French *PUFFY*, *adj.* } *buuffé*; Scot. *buffie*:

and there is an oriental *puf* (Pers.) and Sans. *pu*, wind; all clearly words derived from the sound of wind blown from the mouth. A blast of wind through the lips; a small blast of wind; any thing light or porous; or any thing used to sprinkle light dust with, as hair-powder, &c.: to puff is to blow in the way described: hence to swell the cheeks with wind; breathe thick or hard; swell with wind or air; move with hurry or tumult (which produces puffing); sneer at; treat with scorn, or as light and trifling: as a verb

active to inflate; drive or agitate; swell or elate with pride; the adjective and adverb follow these senses.

Think not of men above that which is written, that no one of you be *puffed up* one against another. *1 Corinthians iv. 6.*

His look like a cockcomb *up puffed* with pride. *Tusser.*

Wherefore do you follow her,  
Like foggy South *puffing* with wind and rain?  
*Shakspeare.*

Seldshown *flammins*  
Do press among the popular throngs, and *puff*  
To win a vulgar station. *Id. Coriolanus.*

Have I not heard the sea, *puffed up* with winds,  
Rage like an angry boar chafed with sweat?  
*Shakspeare.*

This army, led by a tender prince,  
Whose spirit, with divine ambition *puffi*,  
Makes mouths at the invisible event. *Id.*

The Rosemary, in the days of Henry VII. with a sudden *puff* of wind stooped her side, and took in water at her ports in such abundance, as that she instantly sunk. *Raleigh.*

The attendants of courts engage them in quarrels of jurisdiction, being truly *parasiti curiæ*, in *puffing* a court *up* beyond her bounds for their own advantage. *Bacon.*

Then came brave glory *puffing* by  
In silks that whistled, who but he?

He scarce allowed me half an eye. *Herbert*  
Let him fall by his own greatness,  
And *puff* him *up* with glory, till it swell  
And break him. *Denham's Sophy.*

The naked breathless body lies,  
To every *puff* of wind a slave,  
At the beck of every wave,  
That once perhaps was fair, rich, stout, and wise. *Flutman.*

A new coal is not to be cast on the nitre, till the detonation be quite ended; unless the *puffing* matter blow the coal out of the crucible. *Boyle.*

A true son of the church  
Came *puffing* with his greasy bald-pate choir,  
And fumbling o'er his beads. *Dryden.*

The unerring sun by certain signs declares  
When the South projects a stormy day,  
And when the clearing North will *puff* the clouds  
away. *Dryden's Virgil's Georgics.*

I can enjoy her while she's kind,  
But when she dances in the wind,  
And shakes her wings, and will not stay,  
I *puff* the prostitute away. *Dryden.*

An injudicious poet, who aims at loftiness, runs into the swelling *puffy* stile, because it looks like greatness. *Id.*

A *puff* of wind blows off cap and wig. *L'Estrange.*  
The ass comes back again, *puffing* and blowing  
from the chase. *Id.*

Flattering of others, and boasting of ourselves, may be referred to lying; the one to please others, and *puff* them *up* with self-conceit; the other to gain more honour than is due to ourselves. *Ray.*

In garret vile, he with a warming *puff*  
Regales chill fingers. *Philips.*

Some *puff* at these instances, as being such as were under a different economy of religion, and consequently not directly pertinent to ours. *South.*

Why must the winds all hold their tongue?  
If they a little breath should raise;  
Would that have spoiled the poet's song.

Or *puffed* away the monarch's praise?  
Empysemata is a light *puffy* tumour, easily yielding to the pressure of your fingers, and *bursting* again in the instant you take them off. *Warman.*

I have been endeavouring very busily to raise a friendship, which the first breath of any ill-natured by-stander could puff away. *Popé.*

Who stands safest? tell me, is it he that spreads and swells in puffed prosperity? *Id.*

The Phœaciens were so puffed up with their constant felicity, that they thought nothing impossible. *Broome.*

Honor's a puff of noisy breath.

The pipe, with solemn interposing puff,  
Makes half a sentence at a time enough;  
The dozing sages drop the drowsy strain,  
Then pause, and puff—and speak, and pause again. *Watts.*

**PUFFENDORF** (Samuel de), an eminent German lawyer, born in 1631 at Fleh, a village of Misnia, in Upper Saxony. He was son of Elias Puffendorf, minister of that place. After acquiring the sciences at Leipsic, he studied the public law, but refused to take the degree of doctor. He accepted the place of governor to the son of Mr. Coyot, then ambassador from Sweden to the court of Denmark. For this purpose he went to Copenhagen, but, the war being renewed soon after between Denmark and Sweden, he was seized with the ambassador's family. During his confinement, which lasted eight months, as he had no books, he amused himself by meditating on what he had read in Grotius's Treatise De Jure Belli et Pacis, and on Hobbes's political writings. Out of these he drew up a short system, with thoughts of his own, and published it at the Hague in 1660, under the title of *Elementa Jurisprudentiæ Universalis*. The elector Palatine invited him to the university of Heidelberg, where he founded in his favor a professorship of the law of nature and nations, the first of that kind established in Germany. Puffendorf remained at Heidelberg till 1673, when Charles XI. of Sweden invited him to be professor of the law of nature and nations at Lunden; which he accepted. Some years after the king sent for him to Stockholm, and made him his historiographer, and a counsellor. In 1688 the elector of Brandenburg obtained the king's consent that he should come to Berlin, to write the history of the elector, William the Great; and in 1694 made him a baron. He died in 1694, aged sixty-three, of an inflammation in his feet. Of his works, which are numerous, the following are the principal:—  
1. A Treatise on the Law of Nature and Nations. 2. An Introduction to the History of the principal States in Europe. Both these were written in German, and have been translated into English. The former with Barbeyrac's Notes. 3. The History of Sweden, from Gustavus Adolphus's Expedition into Germany to the Abdication of Queen Christina. 4. The History of Charles Gustavus, 2 vols. folio.

**PUFFIN**, *n. s.* Ital *puffino*. A water fowl. Among the first sort we reckon the dipchick, murre, creysers, curlews and *puffins*. *Curew.*

**PUG**, *n. s.* Sax. *piȝa*, a girl. Skinner. A kind name of a monkey, or any thing tenderly loved.

Upon setting him down, and calling him *pug*, I found him to be her favourite monkey. *Addison.*

**PUGANTZ**, or Baka Banya, a free town, at the foot of a hill, on the north-west of Ilungary,

twenty-nine miles east of Neutra, and seventy three E. N. E. of Presburg. Population 2400. It is the seat of a mine-office, connected with mines of gold and silver, inferior only to those of Cremlnitz.

**PUGET** (Peter Paul), one of the greatest painters and sculptors France ever produced, was born at Marseilles in 1623. He was the disciple of Roman, an able sculptor; and went afterwards to Italy, where he studied painting and architecture. In 1657 a dangerous disorder obliged him to renounce the pencil, and devote himself to sculpture; and, being invited to Paris, he obtained a pension of 1200 crowns, as naval sculptor and director of the works. He died at Marseilles in 1695, and left a number of admirable statues both in France and Italy.

**PUGGERED**, *adj.* For puckered. Crowded; complicated.

Nor are we to cavil at the red *pugged* attire of the turkey, and the long excrescency that hangs down over his bill, when he swells with pride.

*More against Atheism.*

**PUGIL**, *n. s.* Fr. *pugille*. What is taken up between the thumb and two first fingers.

Take violets, and infuse a good *pugil* of them in a quart of vinegar. *Bacon's Natural History.*

**PUGLIA**, the ancient Apulia, a large tract on the coast of the Adriatic, Naples, now forming the provinces of **CAPITANATA**, **BARI**, and **OTRANTO**, which see.

**PUGNACIOUS**, *adj.* } Lat. *pugnax*. In-  
**PUGNACIOUSLY**, *adv.* } clinable to fight; quar-  
relsome. We find no instance of the use of this word in our standard writers; but our pugilistic gentlemen, and most of the monkey tribes, furnish illustrations of it.

**PUIKA**, or **POYK**, a river of Austrian Illyria, in Carniola, remarkable for the length of its course under ground. Entering a subterraneous cavern at Adelsberg, it finds its way beneath the surface of the earth eight miles to Planina, where it loses itself again almost immediately, and re-appears at a distance of five miles, under the name of the Laybach. The entrance at Adelsburg is in the form of a Gothic vault, and the appearance extremely grand. The noise of the water ceases for some time, as the traveller advances by a glimmering light; and, when he hears it again, the guides are accustomed to light up a straw fire, which shows that he is now arrived at almost impassable precipices, and that he stands on a natural bridge, while the river rolls below at a great distance. The travellers Valvasor and Keyser penetrated to a second bridge, about four miles from the mouth of the cavern, and saw the water eighty or 100 feet below them.

**PUISNE**, *adj.* French *puis né*. Commonly spoken and written **PUNY**, which see. Younger; later in time; inferior; subordinate; small.

A *puisne* tilter, that spurs his horse but on one side, breaks his staff like a noble goose.

*Shakespeare.*

When the place of a chief judge becomes vacant, a *puisne* judge who hath approved himself deserving, should be preferred. *Bacon.*

If he undergo any alteration it must be in time, or of a *puisne* date to eternity. *Hale.*

PUISSANCE, *n. s.* } Fr. *puissance*. Power;  
 PUIS'SANT, *adj.* } strength; force: powerful;  
 forcible.

PUKE, *n. s.* & *v. n.* } Teut. *spucker*. Vo-  
 PU'KER, *n. s.* } mit: hence an emetic;  
 to vomit: a puker also means an emetic.

The infant

Mewling and puking in the nurse's arms. *Shakspeare.*

PULAWSKI, count Joseph; a distinguished Pole, who, after attempting in vain to restore the independence of his own country, entered the American service. Pulawski had followed the profession of the law, and, in 1768, was at the head of the patriots who formed the confederation of Bar. Eight noblemen only constituted the first assembly of that confederation, and of these, three were the sons and one the nephew of Pulawski. In 1771, at the head of a few accomplices, he seized the person of the king, but the latter having procured his liberation, Pulawski was condemned to death, and obliged to save himself by flight. He soon after came to America, and offered his services to the United States of America against the mother country. Being appointed brigadier-general in the American service, he served both in the northern and the southern army. October 9, 1779, he was mortally wounded in the attack on Savannah, and died two days afterwards.

PUL, or PHUL, the first king of Assyria, upon the division of the empire after the death of Sardanapalus.

PULARUM ISLE, one of the smallest of the Banda Isles, named by early navigators Polaroon, in long. 129° 45' E., and lat. 5° 35' N. The English East India Company obtained possession of it in 1617, but were repeatedly expelled by the Dutch; and it was not until March 1665 that it was formally delivered up by the Dutch.

PULCHERIA, a daughter of the emperor Arcadius, eminent for her virtues. She was mother of Valentinian III., and governed the empire for many years. She died A. D. 452, and was interred at Ravenna, where her tomb is still visible.

PULCHRITUDE, *n. s.* Lat. *pulchritudo*. Beauty; grace; handsomeness; quality opposite to deformity.

Neither will it agree unto the beauty of animals, wherein there is an approved *pulchritude*. *Browne.*

*Pulchritude* is conveyed by the outward senses unto the soul, but a more intellectual faculty is that which relishes it. *More.*

That there is a great *pulchritude* and comeliness of proportion in the leaves, flowers, and fruits of plants, is attested by the general verdict of mankind.

*Ray on the Creation.*

By their virtuous behaviour they compensate the hardness of their favour, and by the *pulchritude* of their souls make up what is wanting in the beauty of their bodies. *South.*

PULCI (Lewis), an eminent Italian poet, born in Florence in 1431. He wrote a celebrated poem on a tournament held at Florence, in which Lorenzo de Medicis was victor, entitled Giostra de Lorenzo de Medicis. He had two brothers equally devoted to the Muses; one of whom wrote an elegy, entitled Bernardo, on the death of the great Cosmo de Medicis. Lewis died about 1487.

PULE, *v. n.* Fr. *piuler*; Ital. *pipolare*, of Lat. *pipilo*. To cry like a chicken; whine.

To have a wretched *puling* fool,  
 A whining mammet in her fortune's tender,  
 To answer, I'll not wed.

*Shakspeare. Romeo and Juliet.*

Let the songs be loud and cheerful, and not chirpings or *pulings*; let the musick likewise be sharp and loud. *Bacon.*

Weak *puling* things unable to sustain  
 Their share of labour, and their bread to gain.

*Druden.*

When ice covered the water, the child bathed his legs; and when he began this custom was *puling* and tender. *Locke.*

This *puling* whining harlot rules his reason,  
 And prompts his zeal for Edward's bastard brood.

*Roue.*

While yet thou wast a grovelling *puling* chit,  
 Thy bones not fashioned, and thy joints not knit,  
 The Roman taught thy stubborn knee to bow,  
 Though twice a Cæsar could not bend thee now.

*Cowper.*

PULEX, the flea, in entomology, a genus of insects belonging to the order of aptera. It has two eyes, and six feet fitted for leaping; the feelers are like threads; the rostrum is inflected, setaceous, and armed with a sting; and the belly is compressed. Fleas bring forth eggs, which they deposit on animals that afford them a proper food. Of these eggs are hatched white worms of a shining pearl color, which feed on the scurfy substance of the cuticle, the downy matter gathered in the piles of clothes, or other similar substances. In a fortnight they come to a tolerable size, and are very lively and active; and, if at any time disturbed, they suddenly roll themselves into a kind of ball. Soon after this they begin to creep, after the manner of silk worms, with a very swift motion. When arrived at their size, they hide themselves, and spin a silken thread out of their mouth, wherewith they form themselves a small round bag or case. Here, after a fortnight's rest, the animalcule bursts out, transformed into a perfect flea; leaving its exuviae in the bag. While it remains in the bag it is milk-white, till the second day before its eruption; when it becomes colored, grows hard, and gets strength; so that upon its first delivery it springs nimbly away. The flea is covered all over with black, hard, and shelly scales or plates, which are curiously jointed, and folded over one another in such a manner as to comply with all the nimble motions of the creature. These scales are finely polished, and beset about the edges with short spikes, in a very beautiful and regular order. Its neck is finely arched, and resembles the tail of a lobster: the head also is very extraordinary; for, from the snout part of it, proceed the two fore legs, and between these is placed the piercer or sucker, with which it penetrates the skin to get its food. Its eyes are very large and beautiful, and it has two short horns or feelers. It has four other legs joined all at the breast. These, when it leaps, fold short, one within another; and then, exerting their spring all at the same instant, they carry the creature to a surprising distance. The legs have several joints, and are very hairy, and terminate in two long and hooked sharp claws. The piercer or

sucker of the flea is lodged between its fore legs, and includes a couple of darts or lancets; which, after the piercer has made an entrance, are thrust farther into the flesh, to make the blood flow from the adjacent parts, and occasion that round red spot, with a hole in the centre of it, vulgarly called a flea-bite. This piercer, its sheath opening sidewise, and the two lancets within it, are very difficult to be seen; unless the two fore legs, between which they are hid, be cut off close to the head: for the flea rarely puts out its piercer, except at the time of feeding, but keeps it folded inwards; and the best way of seeing it is by cutting off first the head and then the fore-legs, and then it is usually seen thrust out in convulsions. By keeping fleas in a glass tube corked up at both ends, but so as to admit of fresh air, their several actions may be observed. They may also be thus seen to lay their eggs, not all at once, but ten or twelve in a day, for several days successively; which eggs will be afterwards found to hatch successively in the same order. The flea may easily be dissected in a drop of water; and thus the stomach and bowels, with their peristaltic motion, may be discovered very plainly, as also their testes and penis, with the veins and arteries. This blood-thirsty insect, which fattens at the expense of the human species, prefers the more delicate skin of women; but preys neither upon epileptic persons, nor upon the dead or dying. It loves to nestle in the fur of dogs, cats, and rats. The nests of river swallows are sometimes plentifully stored with them. Fleas are apterous; walk but little, but leap to a height equal to 200 times that of their own body. This amazing motion is performed by means of the elasticity of their feet, the articulations of which are so many springs. Thus it eludes, with surprising agility, the pursuit of the person on whom it riots. See ENTOMOLOGY.

**PULEX AQUATICUS** of some authors, the monocus pulex of Linnaeus, in entomology, is a species of the genus monocus. See ENTOMOLOGY.

**PULL**, *v. a. & n. s.* } Sax. pullian; Belg. **PULLER**, *n. s.* } *op paolen*. To draw towards one; opposed to push; tear; rend; pluck; draw forcibly; taking *on, off, down, up, &c.*, before the object: the act of pulling; contest; struggle.

He put forth his hand, and *pulled* the dove in. *Genesis* viii. 9.

*Pull* them out like sheep for the slaughter, and prepare them for the day of slaughter. *Jer.* vii. 11.  
He hath turned aside my ways, and *pulled* me in pieces; he hath made me desolate. *Lam.* iii. 2.

What they seem to offer us with the one hand, the same with the other they *pull* back. *Hooker*.

Duke of Glo'ster, scarce himself;  
That bears so shrewd a main; two *pulls* at once;  
His lady banished, and a limb lopt off. *Shakspeare*.  
Shameless Warwick, peace!

Proud setter up and *puller* down of kings. *Id.*  
Although it was judged in form of a statute that he should be banished, and his whole estate confiscated, and his houses *pulled* down, yet his case even then had no great blot of ignominy. *Bacon*.

He was not so desirous of wars, as without just cause of his own to *pull* them upon him. *Hayward*.

Ill fortune never crushed that man, whom good fortune deceived not; I therefore have counselled my friends to place all things she gave them so as she might take them from them, not *pull* them.

*Ben Jonson's Discoveries*.

This wrestling *pull* between Corineus and Gogmagog is reported to have befallen at Dover. *Carew*.

In political affairs, as well as mechanical, it is far easier to *pull* down than build up; for that structure, which was above ten summers a building, and that by no mean artists, was destroyed in a moment.

*Howel's Vocal Forest*.

He begs the gods to turn blind fortune's wheel,  
To raise the wretched, and *pull* down the proud.

*Roscommon*.

When bounteous Autumn rears his head,

He joys to *pull* the ripen'd pear. *Druiden*.

What censure, doubting thus of innate principles, I may deserve from men, who will be apt to call it *pulling* up the old foundations of knowledge, I cannot tell; I persuade myself that the way I have pursued, being conformable to truth, lays these foundations surer. *Locke*.

Flax *pulled* in the bloom will be whiter and stronger than if let stand till the seed is ripe.

*Mortimer*.

They may be afraid to *pull* down ministers and favourites grown formidable.

*Davenant*.

When God is said to build or *pull* down, 'tis not to be understood of an house; God builds and unbuilds worlds. *Burnet*.

I awaked with a violent *pull* upon the ring, which was fastened at the top of my box. *Gulliver*.

A boy came in great hurry to *pull* off my boots.

*Swift*.

**PULLET**, *n. s.* French *poulet*. A young hen.

Brew me a pottle of sack finely.

—With eggs, Sir!

—Simple of itself; I'll no *pullet* sperm in my brewage. *Shakspeare*.

They died, not because the *pullets* would not feed; but because the devil foresaw their death, he contrived that abstinence in them. *Browne*.

I felt a hard tumour on the right side, the bigness of a *pullet's* egg. *Wiseman's Surgery*.

**PULLEY**, *n. s.* Fr. *poulie*; Ital. *polea*; Gr.  $\pi\omicron\lambda\epsilon\omega$ ? A small grooved wheel turning on a pivot or line.

Here *pullies* make the ponderous oak ascend. *Gay*.

Nine hundred of the strongest men were employed to draw up these cords by many *pullies* fastened on the poles, and in three hours I was raised and slung into the engine. *Swift*.

**PULLEY**, in mechanics, one of the five mechanical powers. See MECHANICS.

**PULLICAT**, or **VALLIACATA**, a sea-port on the coast of the Carnatic, twenty-five miles north from Madras. The lake of Pullicat, on which it stands, appears to owe its existence to the sea's breaking through a low sandy beach, and overflowing the lands. Its communications with the sea are extremely narrow. This lake is in extent thirty-three miles from north to south, eleven miles across in the broadest part, and comprehends several large islands. The Dutch established themselves here in 1609, when they built a square fort named Geldria; to which, after the loss of Negapatam, the chief government of their settlements on the Coromandel Coast was transferred. Their imports were arrack, sugar, Japan copper, spices, and other articles, brought

from Batavia. In 1795 the British took possession of Pullicat, and it is now comprehended in the northern Arcot collectorship.

**PULMANNUS** (Theodore), or Poelman, a learned corrector of the sixteenth century, born at Cranenburgh, in the duchy of Cleves, about 1510. He superintended the printing and correcting of the Latin poets from ancient MSS., for the celebrated Plantin's press. He died about 1580.

**PULMO**, the lungs. See **ANATOMY**.

**PULMONARIA**, in botany, lungwort, a genus of the monogynia order, and pentandria class of plants; natural order forty-first, asperifoliæ: cor. funnel-shaped, with its throat pervious: cal. prismatic and pentagonal. There are several species; of which the most remarkable is

*P. officinalis*, common spotted lungwort, or Jerusalem cowslip. This is a native of woods and shady places in Italy and Germany; but has been cultivated in Britain for medical use. The leaves are of a green color, spotted with white; and of a mucilaginous taste, without any smell. They are recommended in phthisis, ulcers of the lungs, &c.; but their virtues in these diseases are not warranted by experience.

**PULMONARY**, *adj.* } Lat. *pulmo*. Belong-  
**PULMONIC**. } ing to the lungs.

An ulcer of the lungs may be a cause of *pulmonick* consumption, or consumption of the lungs.

*Harvey.*

Often these unhappy sufferers, for want of sufficient vigour and spirit to carry on the animal regimen, drop into a true *pulmonary* consumption.

*Blackmore.*

Cold air, by its immediate contact with the surface of the lungs, is capable of producing defluxions upon the lungs, ulcerations, and all sorts of *pulmonick* consumptions.

*Arbuthnot.*

The force of the air upon the *pulmonary* artery is but small in respect to that of the heart.

*Id.*

**PULO BALLY**, an island in the eastern seas, about two miles round, with abundance of wood and water; divided from the island of Bachian by a channel five miles wide.

**PULO BANIAC ISLE**, an island, about twenty-five miles in circumference, on the west coast of Sumatra, between 2° and 3° N. lat.

**PULO BATU**, an island about forty miles off the western coast of Sumatra, called, says Mr. Marsden, by corruption, Mintaon. It is about forty miles long, and twelve broad, in long. 97° 56' E., lat. 0° 20' N.

**PULO LAUT**, an island in the eastern seas, at the south entrance of the Straits of Macassar, near the south-east coast of Borneo. It is of a triangular form, and about 100 miles in circumference: the chief produce is rice. The channel between this island and Borneo is about two miles broad, less or more, and from seven to eight fathoms deep. It forms a good harbour. Long. 116° 24' E., lat. 3° 45' S.

**PULO NAKO-NAKO**, a cluster of isles in the eastern seas, near the western coast of Nias. Large quantities of cocoa-nut oil are prepared here. They are governed by a rajah, who monopolises the produce.

**PULO SANDING**, or **SANDIANG**, two islands in the Eastern seas, near the south-eastern extremity

of the Nassau or Pogy Isles. They are both uninhabited, and the only production that grow on them worth notice is the long nutmeg, and some timber.

**PULO TIMOAN**, an island of the eastern seas, inhabited by a short race of Malays. Byron found them, in the year 1765, a surly set of people, who came down to the beach in great numbers, having a long knife in one hand, a spear headed with iron in the other, and a dagger by their side. They went on shore however; but all they could procure was about a dozen fowls, and a goat and kid, in exchange for some pocket-handkerchiefs. The island is hilly and woody.

**PULO VARELLA**, an island in the Straits of Malacca, about twenty miles from the north-east coast of Sumatra. It is chiefly resorted to by the piratical inhabitants of the neighbouring islands. Long. 99° 36' E., lat. 3° 47' N.

**PULO WAY**, a Spice Island in the eastern seas, about nine miles west of Gorong Apee, is nearly circular, and about a mile and a half in diameter. It has a strong fort, and is esteemed healthy. Long. 130° 26' E., lat. 4° 9' S.

**PULP**, *n. s.*

**PULPOTS**, *adj.* } Fr. *pulpe*; Lat. *pulpa*. Any  
soft mass; the soft part of  
**PULPY**. } fruit: soft, pappy.

The jaw bones have no marrow severed, but a little *pulp* marrow diffused.

*Bacon's Natural History.*

The savoury *pulp* they chew, and in the rind,  
Still as they thirsted, scoop the brimming stream.

*Milton.*

In the walnut and plums is a thick *pulpy* covering, then a hard shell, within which is the seed.

*Ray on the Creation.*

The grub

Oft unobserved invades the vital core,  
Pernicious tenant, and her secret cave  
Enlarges hourly, preying on the *pulp*  
Ceaseless.

*Philips.*

The redstreak's *pulposus* fruit

With gold irradiate, and vermilion shines. *Id.*

Putrefaction destroys the specific difference of one vegetable from another, converting them into a *pulpy* substance of an animal nature.

*Arbuthnot.*

The **PULP** of fruits, in pharmacy, is extracted by infusion or boiling, and passed through a sieve.

**PULPIT**, *n. s.* Fr. *pulpitre*; Lat. *pulpitum*; Ital., Span., and Port., *pulpito*. A raised place where a speaker stands.

Produce his body to the market-place,

And in the *pulpit*, as becomes a friend,

Speak in the order of his funeral. *Shakspeare.*

Their late patron of famous memory (as their dear relique), enshrined in their La Flesche, was, after his death, in their *pulpits* proclaimed tyrant and worse.

*Bp. Hall.*

We see on our theatres the examples of vice rewarded, yet it ought not to be an argument against the art, any more than the impieties of the *pulpit* in the late rebellion.

*Druiden.*

Sir Roger has given a handsome *pulpit* cloth, and railed in the communion-table.

*Alduom.*

Bishops were not wont to preach out of the *pulpit*.

*Ayliffe.*

*Pulpits* their sacred satyr learned to spare.

And vice admired to find a flatt'rer there. *Pope.*

**PULPITUM**, in the Grecian and Roman theatres, a place where the players performed their parts. It was lower than the scena, and higher than the orchestra.

**PULPITUM** was also a moveable desk or pulpit, from which disputants pronounced their dissertations, and authors recited their works.

**PULSE'**, *n. s.* From pull. Leguminous plants. Plants not reaped, but pulled or plucked.

With Elijah he partook,

Or as guest with Daniel at his *pulse*.

*Milton.*

Mortals, from your fellows' blood abstain!  
While corn and *pulse* by nature are bestowed.

*Dryden.*

Tares are as advantageous to land as other *pulses*.  
*Mortimer.*

**PUL'SE**, *n. s. & v. n.*

**PULSA'TION**, *n. s.*

**PUL'SION**.

Fr. *pouls*; Span.

*pulso*; Lat. *pulsus*.

The vibratory motion

of the blood in an artery; oscillation; vibration: to beat as the pulse: pulsation is the vibratory stroke of the pulse; any stroke beating against something opposing: pulsion is, the act of driving forward a fluid, as opposed to suction or traction.

Think you I bear the shears of destiny?

Have I commandment on the *pulse* of life?

*Shakspeare.*

These commotions of the mind and body oppress the heart, whereby it is choaked and obstructed in its *pulsation*.

*Harvey.*

The prosperity of the neighbour kingdoms is not inferior to that of this, which, according to the *pulse* of states, is a great diminution of their health.

*Clarendon.*

This original of the left vein was thus contrived, to avoid the *pulsation* of the great artery.

*Browne.*

Admit it might use the motion of *pulsion*, yet it could never that of attraction.

*More's Divine Dialogues.*

My body is from all diseases free;

My temp'rate *pulse* does regularly beat.

*Dryden.*

The heart, when separated wholly from the body in some animals, continues still to *pulse* for a considerable time.

*Ray.*

The vibrations or *pulses* of this medium, that they may cause the alternate fits of easy transmission and easy reflection, must be swifter than light, and by consequence above seven hundred thousand times swifter than sounds.

*Newton.*

If one drop of blood remain in the heart at every *pulse*, those, in many *pulses*, will grow to a considerable mass.

*Arbuthnot.*

By attraction we do not here understand what is improperly called so, in the operations of drawing, sucking, and pumping, which is really *pulsion* and trusion.

*Bentley.*

**PULSE**, in physiology. See **PHYSIOLOGY** and **MEDICINE**.

**PULTENEY** (William), the celebrated opposer of Sir Robert Walpole, and afterward earl of Bath, was descended from one of the most ancient families in the kingdom, and was born in 1682. He early procured a seat in the house of commons, and distinguished himself against queen Anne's ministry. When king George I. came to the throne, he was made secretary at war; but the friendship between him and Sir Robert Walpole, the premier, was interrupted in 1725, by a suspicion that Walpole wished to

promote the interests of Hanover, to the prejudice of Great Britain. His opposition to Sir Robert was indeed carried to the most indiscriminate length. At last, in 1731, the king with his own hand struck out his name from the list of privy counsellors. But he still continued to attack the minister with a severity of eloquence and sarcasm that worsted every antagonist; and Sir Robert was known to say, he dreaded his tongue more than another man's sword. At length, when Walpole resigned in 1741, Mr. Pulteney was restored to his place in the privy council, and was created earl of Bath; a title purchased at the expense of his popularity. In 1760, in the close of the war, he published A Letter to two Great Men, recommending certain articles to be insisted on in a treaty of peace; which, though the writer was then unknown, was greatly applauded, and went through several impressions. He died in 1764.

**PULTENEY** (Richard), M.D., was born at Loughborough in 1730. He became a surgeon and apothecary at Leicester, whence he communicated some papers on the sleep of plants, and the rare productions of Leicestershire, to the Royal Society, of which he was elected a member in 1762. Two years after he took his doctor's degree at Edinburgh, and went to settle at Blandford in Dorsetshire, where he died, October 13th, 1801. Dr. Pulteney published A General View of the Writings of Linnæus, 4to.; and Sketches of the Progress of Botany in England, 2 vols. 8vo. He left his museum to the Linnæan Society.

**PULTUSK**, or **PULTOVSK**, a celebrated town of Poland, on the Narew, thirty-four miles N. N. E. of Warsaw. It is the residence of the bishop of Plock, and has a Benedictine abbey and gymnasium. The Saxons were defeated here by the Swedes in 1703; and an important engagement took place here between the French and Russians, on 26th December, 1806. Population 2100.

**PULVERIZE'**, *v. a.* } Fr. *pulveriser*; Lat.

**PUL'VERABLE**, *adv.* } *pulveris*. To reduce to powder or dust: possible to be reduced to dust.

If the experiment be carefully made, the whole mixture will shoot into fine crystals, that seem to be of an uniform substance, and are consistent enough to be even brittle, and to endure to be *pulverized* and sifted.

*Boyle.*

In making the first ink, I could by filtration separate a pretty store of a black *pulverable* substance that remained in the fire.

*Id.*

'Tis thine to cherish and to feed

The pungent nose-refreshing weed:

Which, whether *pulverized* it gain

A speedy passage to the brain.

*Couper.*

**PULVERISATION** is performed on friable bodies by pounding or beating them in a mortar, &c.; but, to pulverise malleable ones, other methods must be taken. To pulverise lead, or tin, the method is this: Rub a round wooden box all over the inside with chalk; pour a little of the melted metal nimbly into the box; when, shutting the lid, and shaking the box briskly, the metal will be reduced to powder.

**PUL'VIL**, *n. s. & v. a.* Lat. *pulvillum*. Sweet scents.

Have you *pulvilled* the coachman and postilion, that they may not stink of the stable? *Congreave*



The toilette, nursery of charms,  
Completely furnished with bright beauty's arms,  
The patch, the powder-box, *pucierol*, perfumes. *Gay*.

**PUMEX**, the pumice-stone, a substance frequently thrown out of volcanoes, very full of pores, in consequence of which it is specifically very light, and resembles the frothy slag produced in our iron furnaces. It is of two colors, black and white; the former being that which it has when thrown out of the volcano. It is of a rough and porous consistence, being made up of slender fibres parallel to each other, and very light, so that it swims on water. Pumice-stone is used by silversmiths and other mechanics, for rubbing and smoothing the surface of metals, wood, pasteboard, and stones; for which it is well fitted by its harsh and brittle texture; thus scouring and carrying off all the inequalities.

Jameson arranges pumice under three species, viz. the *glassy*, *common*, and *porphyritic*. 1. Glassy pumice. Color smoke gray. Vesicular. Glistening pearly. Fracture promiscuous fibrous. Translucent. Between hard and semi-hard. Very brittle. Feels rough, sharp, and meagre. Specific gravity 0.378 to 1.44. It occurs in beds in the Lipari Islands.

2. Common pumice. Color nearly white. Vesicular. Glimmering pearly. Fracture fibrous. Translucent on the edges. Semi-hard. Very brittle. Meagre and rough. Specific gravity 0.752 to 0.914. It melts into a gray-colored slag. Its constituents, according to the analysis of Klapproth, silica 77.5, alumina 17.5, natron and potash 3, iron mixed with manganese 1.75. It occurs with the preceding.

3. Porphyritic pumice. Color grayish white. Massive. Minutely porous. Glimmering and pearly. Specific gravity 1.661. It contains crystals of felspar, quartz, and mica. It is associated with claystone, obsidian, pearlstone, and pitchstone porphyry. It occurs in Hungary, at Tokay, &c.

**PUMICE**, *n. s.* Lat. *pumex*, *pumicis*.

So long I shot, that all was spent,  
Though *pumice* stones I hastily hent,  
And threw; but nought availed. *Spenser*.  
Etna and Vesuvius, which consist upon sulphur,  
shoot forth smoke, ashes, and *pumice*, but no water. *Bacon*.

Near the Lucrine lake,  
Steams of sulphur raise a stifling heat,  
And through the pores of the warm *pumice* sweat. *Addison*.

The *pumice* is evidently a slag or cinder of some fossil, originally bearing another form, reduced to this state by fire: it is a lax and spongy matter full of little pores and cavities: of a pale, whitish, grey colour: the *pumice* is found particularly about the burning mountains. *Hill's Materia Medica*.

**PUMP**, *n. s.*, *v. n.*, & *v. u.* } Fr., Belg., and  
**PUMPER**. } Teut. *pompe*;  
Dan. *pomp*; Gr. *πυμπα*? A hydraulic engine of extensive use and great variety of construction; a kind of shoe: to work a pump; to raise or throw any thing liquid, as by means of a pump: to examine artfully; suck: a pumper is he who uses the pump literally, or who extracts the contents of another's mind.

Get good strings to your beads, new ribbons to your *pumps*. *Shakspeare*.

Follow me this jest, now, till thou hast worn a out thy *pump*. *J.*

Thalia's ivy shews her prerogative over comical poesy; her mask, mantle, and *pumps*, are ornaments belonging to the stage. *Peacham*.

The folly of him who *pumps* very laboriously in a ship, yet neglects to stop the leak. *Decay of Piety*.

In the framing that great ship built by Hiero, Athenæus mentions this instrument as being instead of a *pump*, by the help of which one man might easily drain out the water, though very deep. *Wilkins's Dædalus*.

The one's the learned knight, seek out,  
And *pump* them what they come about. *Hudibras*.

Ask him what passes  
Amongst his brethren, he'll hide nothing from you,  
But *pump* not me for politics.

*Otuay's Venice Preserved*.  
A *pump* grown dry will yield no water, unless you pour a little water into it first. *More*.

The flame lasted about two minutes, from the time the *pumper* began to draw out air. *Boyle*.

*Pumps* may be made single with a common *pump* handle, for one man to work them, or double for two. *Mortimer*.

Not finding sufficient room, it breaks a vessel to force its passage, and, rushing through a larger chasm, overflows the cavities about it with a deluge, which is *pumped* up and emptied. *Blackmore*.

The water and sweat  
Splish splash in their *pumps*.

*Swift's Miscellanies*.  
As an impartial traveller I must however tell, that in Stow-street, where I left a draw well, I have found a *pump*. *John-on*.

**PUMPS**. For the theory and construction of a great variety of these useful machines, see **HYDROSTATICS** and **HYDRAULICS**, vol. xi. p. 511 to 523.

**PUMPS, AIR**. See **AIR-PUMPS** and **PNEUMATICS**, Index.

**PUM'PION**, *n. s.* Lat. *pepo*. A plant.

You'll use this gross watery *pumpion*, and teach him to know turtles from jays. *Shakspeare*.

**PUMPION**, or **PUMKIN**. See **CUCURBITA**.

**PUN**, *n. s.* & *v. n.* Johnson seems rather punning when he says, 'to pun is to grind or beat with a pestle; can pun mean an empty sound, like that of a mortar beaten, as clench, the old word for pun, seems only a corruption of clink?' Qu. Lat. *punctum*? A quibble; double meaning, or equivocation; play on a word or words: to use a pun; quibble.

The hand and head were never lost of those  
Who dealt in doggrel, or who *punned* in prose.  
You would be a better man, if you could *pun* like Sir Tristram. *Taylor*.

It is not the word but the figure that appears on the medal: cuniculus may stand for a rabbit or a mine, but the picture of a rabbit is not the picture of a mine: a *pun* can be no more engraven than it can be translated. *Addison*.

But fill their purse, our poet's work is done,  
Alike to them by pathos, or by *pun*. *Pope*.

**PUNA**, a rich city of Peru, in the province of Paucarolla, on the Lake Chucuito or Titicaca. It has a beautiful church for the whites, and another for the Indians; but has suffered much by an insurrection of the Indians. The silver ores in the neighbourhood are rich; but the mines filled with water. Fourteen miles north-west of Chucuito. Long. 70° 26' W., lat. 16° 20' S.

**PUNA**, a woody island, district, and city of South America. The island is situated at the mouth of the Guayaquil, is between six and seven leagues long, and about the same in breadth, and was once populous, containing 20,000 Indians. It was famous in the history of the conquest of Peru. The port of Puna serves for the lading place of large ships, which cannot get over the bar to Guayaquil; the island abounds in mangrove trees. The city is poor, and decayed. The port is eight leagues from the city. Long. 70° 58' W., lat. 2° 50' S.

**PUNCH**, *n. s.* As some have thought of *Lat. potus nauticus*. Mr. Thomson suggests Sans. and Hind. *punchiēne*, of *pun*, *punna*, a beverage, and *cheene*, 'which signifies both Chinese and sugar.' See Fryer, quoted below. A liquor made of spirits, sugar, water, lemons, &c.: the only wholesome ingredient, says Cheyne, being the water.

The West India dry gripes are occasioned by lime juice in *punch*. *Arbutnot on Aliments.*

No brute can endure the taste of strong liquor, and consequently it is against all the rules of hieroglyph to assign those animals as patrons of *punch*. *Swift.*

*Punch* is an Indian word expressing the number of ingredients. *Fryer's Travels.*

**PUN'CH**, *n. s.* Ital. *puncinello*. The buffoon or harlequin of a puppet-show.

Of raree-shows he sung, and *punch's* feats. *Gay.*

**PUNCH**, *v. a. & n. s.* } Fr. *poissonner*;  
**PUN'CHEON**, *n. s.* } Span. *poizon*, *pun-*  
**PUN'CHER**. } *zon*, of Lat. *puncto*.

To cut a hole; bore, or perforate with a sharp instrument: a puncheon and puncher are names for the instrument used: puncheon is also a liquid measure of eighty gallons.

When I was mortal my anointed body  
 By thee was *punched* full of deadly holes. *Shakspeare.*

He granted liberty of coining to certain cities and abbies, allowing them one staple and two *puncheons* at a rate. *Camden.*

The fly may, with the hollow and sharp tube of her womb, *punch* and perforate the skin of the eruca, and cast her eggs into her body. *Ray.*

The shank of a key the *punch* cannot strike, because the shank is not forged with substance sufficient; but the drill cuts a true round hole. *Moxon's Mechanical Exercises.*

In the upper jaw are five teeth before, not incisors or cutters, but thick *punchers*. *Grew.*

By reason of its constitution it continued open, as I have seen a hole *punched* in leather. *Wiseman.*

A **PUNCH** is an instrument of iron or steel, used in several arts, for the piercing or stamping holes in plates of metals, &c., being so contrived as not only to perforate, but to cut out and take away the piece.

A **PUNCHEON**, **PUNCHIN**, or **PUNCHION**, is a little block or piece of steel, on one end of which is some figure, letter, or mark, engraven either en creux or relieve, impressions whereof are taken on metal, &c., by striking it with a hammer on the end not engraven. There are various kinds of these puncheons used in the mechanical arts. Puncheon is also a common name for all those iron instruments used by stone-cutters, sculptors, blacksmiths, &c., for the cutting, in-

cluding, or piercing their several matters. Those of sculptors and statuaries serve for the repairing of statues when taken out of the moulds. The locksmiths use the greatest variety of puncheons; some for piercing hot, others for piercing cold; some flat, some square, some round, others oval, each to pierce holes of its respective figure in the several parts of locks.

**PUNCTILIO**, *n. s.* } Lat. *punctulum*. Nice-  
**PUNCTIL'IOUS**, } ty of behaviour; a nice-  
**PUNCTIL'IOUSNESS**. } ness or exact point:  
 punctilious, nice; exact; fastidious; superstitiously particular: the noun substantive corresponding.

If their cause is bad, they use delays to tire out their adversaries, they feign pleas to gain time for themselves, and insist on *punctilios* in his proceedings. *Kettlewell.*

Common people are much astonished when they hear of those solemn contests which are made among the great, upon the *punctilios* of a public ceremony. *Addison.*

Some depend on a *punctilious* observance of divine laws, which they hope will atone for the habitual transgression of the rest. *Rogers's Sermons.*

*Punctilio* is out of door the moment a daughter clandestinely quits her father's house. *Clarissa.*

**PUNCTO**, *n. s.* Span. *punto*. Nice point of ceremony; the point in fencing.

Vat be all you come for?  
 —To see thee here, to see thee there, to see thee pass thy *puncto*. *Shakspeare. Merry Wives of Windsor.*

The final conquest of Granada from the Moors, king Ferdinand displayed in his letters, with all the particularities and religious *punctos* and ceremonies that were observed in the reception of that city and kingdom. *Bacon's Henry VII.*

**PUNCTUAL**, *adj.* } Fr. *punctuel*. Com-  
**PUNCTUALITY**, *n. s.* } prised, or consisting  
**PUNCTUALLY**, *adv.* } in a point: exact;  
**PUNCTUALNESS**, *n. s.* } nice; scrupulous: the  
 adverb and noun substantives corresponding.

A gentleman *punctual* of his word, when he had heard that two had agreed upon a meeting, and the one neglected his hour, would say of him, he is a young man then. *Bacon.*

For the encouragement of those that hereafter should serve other princes with that *punctuality* as Sophronio had done, he commanded him to offer him a blank, wherein he might set down his own conditions. *Howel's Vocal Forest.*

This earth a spot, a grain,  
 An atom with the firmament compared,  
 And all her numbered stars, that seem to rowl  
 Spaces incomprehensible; for such  
 Their distance argues, and their swift return  
 Diurnal, merely to officiate light  
 Round this opacous earth, this *punctual* spot. *Milton.*

This mistake to avoid, we must observe the *punctual* differences of time, and so distinguish thereof, as not to confound or lose the one in the other. *Brown's Vulgar Errors.*

His memory was serviceable, but not officious; faithful to things and business, but unwillingly retaining the contexture and *punctualities* of the words. *Fell.*

Concerning the heavenly bodies, there is so much exactness in their motions, that they *punctually* come to the same periods to the hundredth part of a minute. *Ray on the Creation.*

Though some of these *punctualities* did not so much conduce to preserve the text, yet all of them shew the infinite care that was taken that there might be no mistake in a single letter. *Grew.*

I freely bring what Moses hath related to the test, comparing it with things as now they stand; and, finding his account to be *punctually* true, I fairly declare what I find. *Woodward.*

The correspondence of the death and sufferings of our Lord is so *punctual* and exact, that they seem rather like a history of events past, than a prophecy of such as were to come. *Rogers.*

He was *punctual* and just in all his dealings.

*Atterbury.*

The most literal translation of the scriptures, in the most natural signification of the words, is generally the best; and the same *punctualness* which debaseth other writings, preserveth the spirit and majesty of the sacred text. *Felton.*

**PUNCTUATION, n. s.** Lat. *punctum*. The act or method of pointing a book or writing.

It ought to do it willingly, without being forced to it by any change in the words or *punctuaton*.

*Addison.*

**PUNCTUATION**, in grammar, the art of pointing, or of dividing a discourse into periods, by points expressing the pauses to be made therein. The ancients were not entirely unacquainted with punctuation. Suidas says that the period and colon were discovered and explained by Thrasymachus, about A. A. C. 380; and Cicero says that Thrasymachus was the first who studied oratorical numbers, which consisted in the artificial structure of periods and colons. It appears from a passage in Aristotle that it was known in his time. Dr. Edward Barnard says it consisted in the different positions of one single point. At the bottom of a letter, thus (A.), it was equivalent to a comma; in the middle, thus (A.), to a colon; at the top (A'), it denoted a full period. Cicero, Quintilian, Seneca, Suetonius, Ælius Donatus, and St. Jerome, all mention that the Romans, as well as the Greeks, made use of points. Peculiar marks, however, were used in different ages. Of these marks of distinction, the Walcote inscription, found near Bath, may serve for a specimen.

IVLIVS VITALIS FABRI  
CESIS LEGV XXV VV V  
STIPENDIORVM &c.

After every word here, except at the end of a line, we see this mark v. There is an inscription in Montfauçon, which has a capital letter laid in an horizontal position, by way of interstitial mark. Our punctuation appears to have been introduced with the art of printing. In the fourteenth century no stops were used but arbitrary marks here and there. In the fifteenth century, we observe their first appearance. We find, from the books of this age, that they were not all produced at the same time; those we meet with in use first being only the comma, the parenthesis, the interrogation, and the full point. To these succeeded the colon, afterwards the semicolon, and, lastly, the note of admiration. The hyphen, the parenthesis, and quotation marks, are also a species of punctuation.

**PUNCTULATE, v. a.** Lat. *punctulum*. To mark with small spots.

The studs have their surface *punctulated*, as if set all over with other studs infinitely lesser.

*Woodward.*

**PUNCTUM STANS**, a phrase by which the schoolmen vainly attempted to bring within the reach of human comprehension the positive eternity of God. Those subtle reasoners seem to have discovered that nothing which is made up of parts, whether continuous or discreet, can be absolutely infinite, and that therefore eternity cannot consist of a boundless series of successive moments. Yet, as if such a series had always existed and were commensurate in duration with the Supreme Being, they compared his eternity to one of the moments which compose the flux of time arrested in its course; and to this eternal moment they gave the name of punctum stans, because it was supposed to stand still, while the rest followed each other in succession, all vanishing as soon as they appeared.

**PUNCTURE, n. s.** Lat. *punctus*. A small prick; a hole made with a sharp point.

With the loadstone of Laurentius Guascus, whatsoever needles or bodies were touched, the wounds and *punctures* made thereby were never felt.

*Brown's Vulgar Errors.*

Nerves may be wounded by scission or *punctures*: the former way being cut through, they are irrecoverable; but when pricked by a sharp-pointed weapon, which kind of wound is called a *puncture*, they are much to be regarded. *Wiseman.*

**PUNDA, or PUNDY**, a town of Hindostan, province of Bejapore, formerly belonging to the Mahrattas. Long. 74° 3' E., lat. 15° 20' N.—There is another place of this name in the Northern Circars. Long. 84° 40' E., lat. 18° 14' N.

**PUNDERPOOL, or PUNDEPORE**, a town of the province of Bejapore, Hindostan, on the left bank of the Beemal. It is not large, but regular and well built, and has a handsome temple dedicated to Vishnu.

**PUNDITS, or PANDITS**, learned Brahmins devoted to the study of the Shanscrit language, and to the ancient sciences, laws, and religion of Hindostan.

**PUNGENT, adj.** } Lat. *pungens*. Prick-  
**PUNGENCY, n. s.** } ing; acrid; sharp: pun-  
gency is, power of pricking, or piercing; keen-  
ness; acridness.

An opinion of the successfulness of the work is as necessary to found a purpose of undertaking it, as the authority of commands, the persuasiveness of promises, *pungency* of menaces, or prospect of mischiefs upon neglect can be. *Hammond.*

The latter happening not only upon the *pungent* exigencies of present or impending judgments, but in the common service of the church. *Fell.*

When he hath considered the force and *pungency* of these expressions applied to the fathers of that Nicene synod by the western bishops, he may abate his rage towards me. *Sittingfleet.*

It consists chiefly of a sharp and *pungent* manner of speech; but partly in a facetious way of jesting. *Dryden.*

Do not the sharp and *pungent* tastes of acids arise from the strong attraction, whereby the acid particles rush upon and agitate the particles of the tongue?

*Newton's Optics.*

Any substance, which by its *pungency* can wound the worms will kill them, as steel and hartshorn.

*Arbuthnot.*

Just where the breath of life his nostrils drew,  
A charge of snuff the wily virgin threw;  
The gnomes direct to every atom just,  
The pungent grains of titillating dust. *Pope.*  
Thou canst set him on the rack,  
Inclose him in a wooden tower,  
With pungent pains on every side;  
So Regulus in torments died. *Swift's Miscellanies.*

**PUNIC WARS.** See **CARTHAGE.**

**PUNICA**, the pomegranate tree, a genus of the monogynia order and icosandria class of plants; natural order thirty-sixth, pomaceæ: *CAL.* quinquefid superior; petals five; fruit a multilocular and polyspermous apple. 1. *P. granata*, the common pomegranate, rises with a free stem, branching numerously all the way from the bottom, growing eighteen or twenty feet high; with spear-shaped, narrow, opposite leaves; and the branches terminated by the most beautiful and large red flowers, succeeded by large roundish fruit as big as an orange, having a hard rind filled with soft pulp and numerous seeds. There is a variety with double flowers, remarkably beautiful; and one with striped flowers.

2. *P. anan*, the dwarf American pomegranate, rises with a shrubby stem branching four or five feet high, with narrow short leaves and small red flowers, succeeded by small fruit; begins flowering in June, and continues till October. Both these species are propagated by layers: the young branches are to be chosen for this purpose, and autumn is the proper time for laying them. Those of the common sort may be trained either as half or full standards, or as dwarfs. But those designed for walls must be managed as directed for peaches. The dried flowers of the double-flowered pomegranate are possessed of an astringent quality; for which reason they are recommended in diarrhœas, dysenteries, &c., where astringent medicines are proper. The rind of the fruit is also a strong astringent, and as such is occasionally made use of.

**PUNISH**, *v. a.* } *Lat. punio; Fr. punis-*  
**PUNISHABLE**, *adj.* } *sable, punition.* To chas-  
**PUN'ISHER**, *n. s.* } tise; afflict with penal-  
**PUN'ISHMENT**, } ties for a crime; avenge  
**PUN'ITION**, } or revenge with death:  
**PUN'ITIVE**, *adv.* } punishable, worthy of o-

demanding punishment: punisher, he who inflicts it: punishment and punition, the penalty of crime: punitive, awarding or inflicting that penalty.

If you will not hearken I will punish you seven times more for your sins. *Leviticus. xxvi. 18.*

The house of endless pain is built thereby,  
In which ten thousand sorts of punishments  
The cursed creatures do eternally torment.

*Spenser.*

Theft is naturally punishable, but the kind of punishment is positive, and such lawful, as men shall think with discretion convenient to appoint.

*Hooker.*

Unless it were a bloody murderer,  
I never gave them condign punishment.

*Shakspeare.*

Neither is the cylinder charged with sin, whether God or men, nor any punitive law enacted by either against its rolling down the hill.

*Hammond's Fundamentals.*

He that doubts whether or no he should honour his parents, wants not reason, but punishment.

*Holyday.*

Their bribery is less punishable when bribery opened the door by which they entered,

*Taylor.*

Will he draw out,

For anger's sake, finite to infinite

In punished man?

This knows my punisher; therefore as far  
From granting me, as I from begging peace.

*Milton.*

A greater power

Now ruled him, punished in the shape he sinned.

*Dryden.*

Say, foolish one—can that unbodied fame,  
For which thou barterest health and happiness,  
Say, can it soothe the slumbers of the grave—  
Give a new zest to bliss, or chase the pangs  
Of everlasting punishment condign? *Kirke White.*

**PUNISHMENT OF CRIMES.** Dr. Paley was the last, and we believe will be the final author of any celebrity, who will be found to vindicate the general spirit of our criminal jurisprudence, in which the punishment has been any thing but the prevention of crimes. It has been constructed upon no general system of legislation. Sometimes the magistrate is clothed with a species of vindictive justice, which it seems doubtful, at least, if ever the Supreme Being delegated to any creature; at other times he is the minister of a particular order of men, a particular caste, or class; as in the administration, for instance, of the appalling enactments of the game laws: again he feebly endeavours at the legitimate, perhaps only, end of human legislation, the prevention of crimes, by punishments which, if they effected their object, are wholly disproportioned to the offence. It seems indeed to have been forgotten that the infliction of some kinds of punishment may in itself constitute a crime. Again, it has been forgotten that it is one thing to enact a law, and another to give it operation. The moral feelings will come into exercise among a people like our own, and predominate occasionally, and even steadily, beyond the force of attachment to any human institution. An ostensible and real equity will therefore be demanded in a body of laws, devolving on such a people to execute.

Dr. Paley, as Sir Samuel Romily has remarked, himself enumerates the several aggravations which ought to guide the magistrate in the selection of objects of condign punishment; and mentions principally three—repetition, cruelty, and combination; which aggravations, Sir Samuel remarks, are as capable of being clearly and accurately described in written laws, and as proper to be submitted to the decision of a jury, as the crimes themselves. But Paley proceeds to say, that, 'by this expedient (meaning the multiplication of capital punishments), few actually suffer death, whilst the dread and danger of it hangs over the crimes of many;' and then that, 'the wisdom and humanity of this design furnish a just excuse for the multiplicity of capital offences, which the laws of England are accused of creating, beyond those of other countries.' We may oppose to this extraordinary reasoning, the sagacious and sound observation of the marquis Beccaria, that, where the

consequences of crimes are problematical, additional force is rather given to the passions. With respect to the second remark of Dr. Paley, above noticed, it is impossible not to be surprised, with Sir Samuel Romilly, that, in this mode of administering the law, an apology should be found for the great number of our statutes creating capital offences; for certainly 'one would have imagined that one advantage of such a system, by which it is left to those who exercise the law to discriminate, and to find out the circumstances which are to characterize, to extenuate, or to aggravate offences, would be, that the laws, being extremely general, might be few in number, and simple and concise in their enactments. Were we to frame laws which should distinguish accurately the general character of different offences, and enumerate all the peculiar aggravations with which they might be attended, and should leave unforeseen and unnoticed no human action which was dangerous by its example, or heinous in its circumstances, we might, indeed, have a good excuse to offer for the multiplicity of our penal laws.'

One remark more from Sir Samuel Romilly.— The power of suspending the laws by granting pardons is exclusively in the king, and it is a prerogative of a very transcendental character. But in the exercise of that discretion, with which, in judicial practice, at least, the judge is invested in dispensing justice on his circuit, he is made the depository of the royal clemency; he administers the law; he suspends its execution. Still, however, it is through the king alone that lenity after sentence can reach the case of the prisoner. It must happen, therefore, that 'the convicts pardoned, so much exceeding in number those against whom the law is suffered to take its course, and the few who are executed, not the many who are pardoned, appearing to form the exceptions to a general rule, this prerogative assumes, in practice, an aspect of severity, not of mercy, and the crown seems to single out its victims for punishment, not to select the objects to whom it should extend its clemency.'

On the practical consequences of this system we have not room to dwell: they are well stated in Mr. Buxton's speech on the bill for mitigating the criminal law, 23d May, 1821. Juries will not convict; but, to save the criminal from the law they are sworn to administer, resort to the most palpable contradiction. We select an instance or two at random.

Mary Whiting was indicted for stealing seven guineas and 34s., in the house of John Sun. Verdict, guilty of stealing to the value of 39s.

Jonathan Smith was indicted for stealing £20 in money in the house of J. Marsh. Guilty of stealing to the value of 39s.

Joseph Court was indicted for stealing eight pairs of gold ear-rings, value £3 16s.; 121 other pairs of ditto, value £74 10s. 6d.; forty-eight pairs of ditto, value £12 12s.; 204 pairs of ditto, value £36 9s.; twenty-four pairs of ditto, value £6 6s.; 2488 gold beads, value £72 18s.; 864 colored beads, value £18; 144 pairs of gold ear-rings, value £20 8s.; three pairs of gold

enamelled bracelets, value £9; eighteen pairs of gold ditto, value £11 7s. 6d.; three small cases for bracelets, value 6s.; thirty-six gold seals, value £33 12s.; twelve gold lockets, value £3; and a parcel of shoes, value 14s. 8d.; the property of Messrs. Mackenzie and Grey, in a lighter belonging to them on the Thames navigable river. Guilty of stealing to the value of 39s.!

We can only add that the proposed alterations of Sir Samuel Romilly had in vain been advocated by Sir James Mackintosh and Mr. Buxton in parliament, until a distinguished member of the government, Mr. Secretary Peel, adopted in a great measure the views of that enlightening statesman: he has been obliged to leave much that is desirable (the entire subject of forgery, for instance) untouched, but he has done much, and excited the just confidence of the nation that he will not fail shortly to follow up this important subject, and do all that existing and long seated prejudices in high quarters will permit.

PUNK, *n. s.* Barb. Lat. *putanica*. A whore; common prostitute.

She may be a *punk*; for many of them are neither maid, widow, nor wife. *Shakspeare.*

And made them fight like mad or drunk,  
For dame religion as for *punk*. *Hudibras.*

Near these a nursery erects its head,  
Where unfledged actors learn to laugh and cry,  
Where infant *punks* their tender voices try. *Dryden.*

PUNSTER, *n. s.* From *pun*. A quibbler; a low wit.

His mother was cousin to Mr. Swan, gamester and punster of London. *Arbutnot and Pope.*

PUNT, *v. n.* Ital. *punto*. A point. To play at basset or ombre.

One is for setting up an assembly for basset, where none shall be admitted to *punt* that have not taken the oaths. *Addison.*

When a duke to Jansen *punts* at White's,  
Or city heir in mortgage melts away,  
Satan himself feels far less joy than they. *Pope.*

PUNY, *adj. & n. s.* Fr. *puis ne*. Young; inferior; petty; an inexperienced person.

Is not the king's name forty thousand names?  
Arm, arm, my name; a *puny* subject strikes  
At thy great glory. *Shakspeare's Richard III.*

Drive

The *puny* habitants; or, if not drive,  
Seduce them to our party. *Milton.*

Jove at their head ascending from the sea.  
A shoal of *puny* powers attend his way. *Dryden.*

PUPA, in entomology, a term now used by zoologists for that state of insects formerly called aurelia, and chrysalis. See CHRYSALIS, and ENTOMOLOGY.

PUPIENAS (M. Claudius Maximus), a man of an obscure family, the son of a blacksmith, who, by his merit, raised himself to the highest offices in the Roman armies; and became successively a pretor, consul, prefect of Rome, and a governor of a province. On the death of Gordian I. and II., he was elected emperor together with Balbinus by the senate; but, his colleague and he disagreeing, the pretorian guards murdered them both, A. D. 326.

**PUP'IL**, *n. s.* Ital. *pupilla*; Lat. *pupula*. 'The apple of the eye.

Looking in a glass, when you shut one eye, the pupil of the other, that is open, dilateth.

*Bacon's Natural History.*

The uvea has a musculous power, and can dilate and contract that round hole in it called the pupil of the eye.

The rays, which enter the eye at several parts of the pupil, have several obliquities to the glasses.

*Newton's Opticks.*

**PUP'IL**, *n. s.* } Fr. *pupillé*; Lat. *pupillus*.  
**PUP'ILAGE**, } A scholar; a ward: one  
**PUP'ILARY**, *adj.* } under the care of a tutor,  
 or guardian: pupilage, the state of being under such care: pupilary, pertaining to a ward or pupil.

Three sons he dying left, all under age,

By means whereof their uncle Vortigern

Usurp'd the crown during their *pupilage*;

Which the infants' tutors gathering to fear,

Them closely into Armorick did bear. *Spenser.*

My master sues to her, and she hath taught her suitor,

He being her *pupil*, to become her tutor.

*Shakespeare.*

One of my father's servants,

With store of tears, this treason 'gan unfold,

And said my guardian would his *pupil* kill.

*Fairfax.*

Tutors should behave reverently before their *pupils*.

*L'Estrange.*

The severity of the father's brow, whilst they are under the discipline of *pupilage*, should be relaxed as fast as their age, discretion, and good behaviour allow.

*Id.*

So some weak shoot, which else would poorly rise,  
 Jove's tree adopts, and lifts him to the skies;  
 Through the new *pupil* soft'ning juices flow,  
 Thrust forth the gems, and give the flow'rs to blow.

*Tickel.*

**PUPIL**, in the civil law, a boy or girl not yet arrived at the age of puberty; i. e. the boy under fourteen years, the girl under twelve.

**PUPIL**, in anatomy, a little aperture in the middle of the uvea and the iris of the eye, through which the rays of light pass to the crystalline humor, in order to be painted on the retina, and cause vision. See **ANATOMY**.

**PUP'PET**, *n. s.* } Fr. *poupée*; Ital. *puppa*;

**PUP'PETMAN**, } Lat. *pupus*. A small wooden

**PUP'PETSHOW**. } image; a doll; a wooden

tragedian: puppetman is the master of a puppet or puppetshow.

Once *Zelmanc* could not stir, but that, as if they had been *puppets* whose motion stood only upon her pleasure, *Basilius* with serviceable steps, *Gynecia* with greedy eyes, would follow her.

*Sidney.*

Oh excellent motion! oh exceeding puppet!

*Shakespeare.*

Divers of them did keep in their houses certain things made of cotton wool, in the manner of *puppets*.

Tim, you have a taste I know,

And often see a *puppetshow*.

*Swift.*

Why is a handsome wife adored

By every coxcomb but her lord?

From yonder *puppetman* enquire,

Who wisely hides his wood and wire.

*Id.*

**PUP'PY**, *n. s.* Fr. *poupée*; Lat. *pupus*. A whelp; progeny of a bitch; a name of contempt for a poor or pert young person.

He

Talks as familiarly of roaring lions,

As maids of thirteen do of *puppy* dogs.

*Shakespeare.*

I found my place taken up by an ill-bred awkward *puppy*, with a money bag under each arm.

*Addison.*

Nature does the *puppy's* eyelid close,

Till the bright sun has nine times set and rose.

*Gay.*

**PURBACH** (George), a German astronomer, born at the village of Purbach, in 1423. He studied philosophy, divinity, and astronomy, at Vienna, and paid particular attention to the latter. He composed Astronomical Tables, and invented several mathematical instruments. He also translated Ptolemy's *Almagest*, and published several tracts of his own. He died in 1462.

**PUR'BLIND**, *adj.* From poreblind, which is still used in Scotland; pore and blind. Near-sighted; shortsighted.

'Tis known to several

Of head piece extraordinary; lower messes,

Perchance, are to this business *purblind*.

*Shakespeare.*

*Purblind man*

Sees but a part o' the chain, the nearest links;

His eyes not carrying to that equal beam,

That poises all above. *Dryden and Lee's Oedipus.*

**PURCELL** (Henry), a celebrated master of music. He was made organist to Westminster Abbey in the end of the reign of Charles II. His principal works have been published under the title of *Orpheus Britannicus*. He died in 1695, aged thirty-seven; and was interred in Westminster Abbey, where he has a monument.

**PURCHAS** (Samuel), an English divine, celebrated as the compiler of a valuable collection of voyages, was born in 1577, at Thackstead in Essex. After studying at Cambridge, he obtained the vicarage of Eastwood in Essex; but, leaving that cure to his brother, he settled in London, to carry on the great work in which he was engaged. He published the first volume in folio in 1613, and the last four twelve years after, under the title of *Purchas his Pilgrimage*, or *Relations of the World*, and the Religions observed in all ages and places. Meanwhile he was made rector of St. Martin's, Ludgate, in London, and chaplain to Dr. Abbot, archbishop of Canterbury. His *Pilgrimage*, and *Hackluyt's Voyages*, led the way to other collections of that kind, and have been justly esteemed. But unhappily by his publishing he involved himself in debt. He died about 1628.

**PUR'CHASE**, *v. a. & n. s.* } Fr. *pourchasser*.

**PUR'CHASEABLE**, *adj.* } To acquire; ob-

**PUR'CHASER**, *n. s.* } tain at any ex-

pende of labor, danger, &c.; to buy for a price: purchaseable, that may be purchased or bought: purchaser, he who makes a purchase; a buyer.

His sons buried him in the cave which Abraham purchased of the sons of Heth.

*Genesis xxv.*

I will be deaf to pleading and excuses,

Nor tears nor prayers shall purchase out abuses;

Therefore use none.

*Shakespeare.*

Upon one only alienation and change, the *pur-chaser* is to pass both licence, fine, and recovery.

*Bacon.*

A world who would not purchase with a bruise ?

*Milton.*

Money being the counterbalance to all things purchasable by it, as much as you take off from the value of money, so much you add to the price of things exchanged for it.

*Locke.*

Most of the old statues may be well supposed to have been cheaper to their first owners, than they are to a modern purchaser.

*Addison.*

Our thriving dean has purchased land ;

A purchase which will bring him clear

Above his rent four pounds a year.

*Swift.*

PURE, *adj.*

PURELY, *adv.*

PURENESS, *n. s.*

PURIFICATION,

PURIFIER,

PURIFY, *v. a., & v. n.*

PURITY, *n. s.*

French *pur, pure ;*

Belg. *puer ;* Italian,

Span. and Port. *puro ;*

Lat. *purus.* Clean ;

clear ; unmingled ;

free ; incorrupt ;

chaste ; mere : hence

morally or ritually clean ; holy ; guiltless : the adverb and noun substantive corresponding : purification, the act of cleansing or making pure : purifier, he who performs it : to purify, to make clear, clean, guiltless, free from guilt or corruption : purity is synonymous with pureness.

All of them were pure, and killed the passover.

*Est.*

Who can say, I have made my heart clean, I am pure from my sin ?

*Proverbs* xx. 9.

I will purely purge away thy dross, and take away all thy tin.

*Isaiah.*

As oft as I read those comedies, so oft doth sound in mine ear the pure fine talk of Rome.

*Ascham.*

Thou purest stone, whose pureness doth present

My purest mind.

*Sidney.*

Could I come to her with any detection in my hand, I could drive her then from the ward of her purity, her reputation, and her marriage vow.

*Shakespeare.*

An essence eternal and spiritual, of absolute pureness and simplicity.

*Raleigh.*

If any bad blood should be left in the kingdom, an honourable foreign war will vent or purify it.

*Bacon's Henry VII.*

Water is the symbol of purification of the soul from sin, and bread and wine of Christ's body and blood ; therefore the symbols receive the names of what they sign.

*Taylor.*

The lord of the castle was a young man of spirit, but had lately, out of pure weariness of the fatigue, and having spent most of his money, left the king.

*Clarendon.*

Hypocrites austerely talk,

Defaming as impure what God declares

Pure, and commands to some, leaves free to all.

*Milton.*

My love was such,

It could, though he supplied no fuel, burn ;

Rich in itself, like elemental fire,

Whose pureness does no aliment require.

*Dryden.*

If God gives grace, knowledge will not stay long behind ; since it is the same spirit and principle that purifies the heart, and clarifies the understanding.

*South's Sermons.*

Her urn

Pours streams select and purity of waters.

*Prior.*

Upon the particular observations on the metallick and mineral bodies, I have not founded any thing but what purely and immediately concerns the natural history of those bodies.

*Woodward.*

Death sets us safely on shore in our long expected

Canaan, where there are no temptations, no danger of falling, but eternal purity and immortal joys secure our innocence and happiness for ever.

*Wals.*

Her guiltless glory just Britannia draws

From pure religion, and impartial laws.

*Tichel.*

I converse in full freedom with men of both parties ; and, if not in equal number, it is purely accidental, as having made acquaintance more under one ministry than another.

*Swift.*

Pure and mixt, when applied to bodies, are much akin to simple and compound ; so a guinea is pure gold, if it has in it no alloy.

*Watts's Logick.*

From the body's purity, the mind

Receives a secret aid.

*Thomson.*

Hope, as an anchor firm and sure, holds fast

The Christian vessel, and defies the blast.

Hope ! nothing else can nourish and secure

His new-born virtues, and preserve him pure.

*Cowper.*

PURFILE, *n. s.* Fr. *pourfilee.* A sort of ancient trimming for women's gowns.

A goodly lady clad in scarlet red,

Purfiled with gold and pearl of rich assay.

*Spenser.*

Emroid tuffs, flowers, purfiled blue and white,

Like sapphire, pearl, in rich embroidery,

Buckled below fair knighthood's bending knee.

*Shakespeare.*

Iris there with humid bow

Waters the odorous banks that blow,

Flowers of more mingled hue

Than her purfiled scarf can shew.

*Milton.*

In velvet white as snow the troop was gowned,

Their hoods and sleeves the same, and purfiled o'er

With diamonds.

*Dryden.*

PURFLEET, a village of England, in Essex, on the north bank of the Thames, famous for its extensive lime-works. It has also a large magazine of Gunpowder. It is four miles west of Grays, and nineteen east of London.

PURGE, *v. a., v. n., & n. s.* Fr. *purger ;*

PURGATION, *n. s.* Lat. *purgo.* To

PURGATIVE, *adj.* cleanse ; clari-

PURGATORY, *n. s.* fy ; scour ; e-

vacuate the body ; clear from guilt or charge :

purification is the act of purging in any way :

purgative, having the power to purge or evacuate ;

cathartic : purgatory, a place which the Roman-

ists suppose to be devoted in the other world to

cleansing men from impurities.

I will purge out from among you the rebels.

*Ezek.* xx. 38.

The blood of Christ [shall] purge our conscience from dead works to serve God.

*Heb.* ix. 14.

Thou thy folk through pains of purgatory,

Dest bear unto thy bliss. *Spenser's Hymn on Love.*

If any man doubt, let him put me to my purgation

*Shakespeare.*

To the English court assemble now

From ev'ry region apes of idleness ;

Now neighbour confines purge you of your scum. *Id.*

He, I accuse,

Intends t'appear before the people, hoping

To purge himself with words. *Id.*

This shall make

Our purpose necessary, and not envious ;

We shall be called purgers, not murderers. *Id.*

Sir Philip Calthrop purged John Drakes, the shoemaker of Norwich, of the proud humour.

*Camden.*

*Purging* medicines have their *purgative* virtue in a fine spirit, they endure not boiling without loss of virtue.

Marquis Dorset was hastening towards him, to *purge* himself of some accusation. *Id. Henry VII.*

It is of good use in physick, if you can retain the *purging* virtue, and take away the unpleasant taste of the *purger*. *Bacon.*

All that is filled, and all that which doth fill,  
All the round world to man is but a pill;  
In all it works not, but it is in all  
Poisonous, or *purgative*, or cordial. *Donne.*

Simplicity and integrity in the inward parts may *urge* out every prejudice and passion.

*Decay of Piety.*

A certain monk saw some souls roasted upon spits like pigs, and some devils basting them with scalding lard; but a while after they were carried to a cool place, and so proved *purgatory*. *Bp. Taylor.*

In this age there may be as great instances produced of real charity as when men thought to get souls out of *purgatory*. *Stillingfleet.*

Fills, not laxatives, I like;

Of these his gain the sharp physician makes,  
And often gives a *purge*, but seldom takes.

*Druden.*

We do not suppose the separation finished, before the *purgation* of the air began. *Burnet.*

Syphax, we'll join our cares to *purge* away  
Our country's crimes, and clear her reputation.

*Addison.*

Air ventilates and cools the mines, and *purges* and frees them from mineral exhalations. *Woodward.*

He was no great friend to *purging* and clysters; he was for mixing aloes with all *purges*. *Arbuthnot.*  
Lenient *purgatives* evacuate the humours. *Wiseman.*

**PURGATION**, in law, signifies the clearing a person's self of a crime of which he is suspected and accused before a judge. This *purgation* is either canonical or vulgar. Canonical *purgation* is prescribed by the canon law, and the form thereof in the spiritual court is usually thus: The person thus suspected takes his oath that he is innocent of the crime charged against him; and at the same time brings some of his neighbours to make oath that they believe he swears truly. Vulgar *purgation* was anciently by fire and water, or else by combat, and was practised here till abolished by our laws.

**PURGATION**, in medicine, is an excretory motion arising from a quick and orderly contraction of the fleshy fibres of the stomach and intestines, whereby the chyle, corrupted humors, and excrements lodged therein, are protruded further, and at length quite excluded the body by stool.

**PURGATORY** is a place in which the just, after death, are supposed by the Roman Catholics to expiate certain offences which do not merit eternal damnation. Broughton has endeavoured to prove that this notion has been held by Pagans, Jews, and Mahometans, as well as by Christians; and that in the days of the Maccabees the Jews believed that sin might be expiated by sacrifice, after the death of the sinner, cannot be questioned. Much abuse has been poured upon the church of Rome for her doctrine of *purgatory*, and many false representations have been made of the doctrine. The following view of it is taken from work which is considered as a standard by the British Catholics: 1. Every sin,

how slight soever, though no more than an idle word, as it is an offence to God, deserves punishment from him, and will be punished by him hereafter, if not cancelled by repentance here. 2. Such small sins do not deserve eternal punishment. 3. Few depart this life so pure as to be totally exempt from spots of this nature, and from every kind of debt due to God's justice. 4. Therefore few will escape without suffering something from his justice for such debts as they have carried with them out of this world; according to that rule of divine justice, by which he treats every soul hereafter according to its works, and according to the state in which he finds it in death. From these propositions, which the Papist considers as so many self-evident truths, he infers that there must be some third place of punishment; for, since the infinite goodness of God can admit nothing into heaven which is not clean and pure from all sin both great and small; and his infinite justice can permit none to receive the reward of bliss, who as yet are not out of debt, but have something in justice to suffer: there must of necessity be some place or state where souls departing this life, pardoned as to the eternal guilt or pain, yet obnoxious to some temporal penalty, or with the guilt of some venial faults, are purged and purified before their admittance into heaven. Such is the Popish doctrine of *purgatory*.

**PURIFICATION** is a ceremony which consists in cleansing any thing from a supposed defilement. The Pagans, before they sacrificed, usually washed themselves in water; and they were particularly careful to wash their hands, because with these they were to touch the victims consecrated to the gods. They likewise washed the vessels with which they made their libations. The Mahometans also use purifications previous to prayer; which are of two kinds, bathing, or washing the face, hands, and feet. The first is required only in extraordinary cases, as after having lain with a woman, touched a dead body, &c. But where water cannot be had, or when it may be of prejudice to a person's health, they are allowed to use fine sand, or dust, by clapping their open hands on the sand, and passing them over the parts, in the same manner as if they were dipped in water. There were also many legal purifications among the Hebrews. When a woman was brought to bed of a male child, she was esteemed impure for forty days; and when of a female, for sixty: at the end of which time she carried a lamb to the door of the temple to be offered for a burnt-offering, and a young pigeon or turtle for a sin-offering; and after this ceremony she was declared pure.

**PURIM**, or the Feast of Lots, a solemn festival of the Jews, instituted in memory of the deliverance they received, by means of Mordecai and Esther, from Haman's wicked attempt to destroy them.

**PURITAN**, *n. s.* } From pure. A name  
**PURITANICAL**, *adj.* } originally given to the  
**PURITANISM**, *n. s.* } Dissenters of England,  
from the great professions of purity in their creed and practice: puritanical is relating to, or resembling, the puritans: puritanism, their religious systems or opinions.



The schism which the papists on the one hand, and the superstition which the *puritans* on the other, lay to our charge, are very justly chargeable upon themselves.

Such guides set over the several congregations will misteach them, by instilling into them *puritanical* and superstitious principles, that they may the more securely exercise their presbyterian tyranny.

Walton.

A serious and impartial examination of the grounds, as well of popery as *puritanism*, according to that measure of understanding God hath afforded me.

Id.

PURITAN was a name formerly given in derision to the dissenters from the church of England, on account of their profession to follow the pure word of God, in opposition to all traditions and human constitutions. It was likewise given in the primitive church to the Novatian schismatics, because they would never admit to communion any one who from dread of death had apostatised from the faith. See NOVATIANS.

PURL, *n. s. & v. a.* Supposed by Minshew to be contracted from *purfle*. An embroidered and puckered border: to decorate with embroidery.

Himself came in next after a triumphant chariot made of carnation velvet, enriched with *purl* and pearl.

Sidney.

The jagging of pinks is like the inequality of oak leaves; but they seldom have any small *purl*.

Bacon.

When was old Sherwood's head more quaintly curled.

Or nature's cadle more enchased and *purled*?

Ben Jonson.

PURL, *v. n.* Swed. *porla*. To murmur.—Lye. To murmur; to flow with a gentle noise.

Tones are not so apt to procure sleep, as some other sounds; as the wind, the *purling* of water, and humming of bees.

Bacon.

All fish from sea or shore

Freshet, or *purling* brook, or shell or fin.

Milton.

My flow'ry theme,

A painted mistress, or a *purling* stream.

Around the adjoining brook, that *purls* along  
The vocal grove, now fretting o'er a rock.

Thomson.

PURLIEU, *n. s.* Form PURL, a border. The grounds on the border of a forest; border; enclosure; district.

In the *purlieus* of this forest stands

A sheepcote, fenced about with olive trees.

Shakspeare.

Such civil matters fall within the *purlieus* of religion.

L'Estrange.

To understand all the *purlieus* of this place, and to illustrate this subject, I must venture myself into the haunts of beauty and gallantry.

Spectator.

He may be left to rot among thieves in some stinking jail, merely for mistaking the *purlieus* of the laws.

Swift.

PURLIEU, in law, signifies all that ground near any forest which, being made forest by king Henry II. Richard I. and king John, was afterwards by perambulations and grants of Henry III. severed again from the same, and made *purlieu*; that is to say, pure and free from the laws of the forest. The word is derived from the French *pur*, pure, and *lieu*, place.

PURLOIN', *v. a.* Of doubtful etymology. Skinner deduces it from French *pour* and *loin*. Mr. Lye from Saxon *puþloulhnan*, to lie hid. To steal; to take by theft.

Not *purloining*, but shewing all good fidelity.

Titus ii. 10.

He, that brave steed there finding ready dight,  
*Purloined* both steed and spear, and ran away full light.

Spenser.

They, not content like felons to *purloin*,  
Add treason to it, and debase the coin.

Denham.

The Arimaspan by stealth

Had, from his wakeful custody, *purloined*

The guarded gold.

Milton.

Some writers make all ladies *purloined*,

And knights pursuing like a whirlwind.

Hudibras.

When did the muse from Fletcher scenes *purloin*,  
As thou whole Eth'ridge dost transfuse to thine?

Dryden.

It may seem hard to see publick *purloiners* sit upon  
the lives of the little ones, that go to the gallows.

L'Estrange.

Your butler *purloins* your liquor, and the brewer  
sells your hogwash.

Arbuthnot's History of John Bull.

Prometheus once this chain *purloined*,

Dissolved, and into money coined.

Swift.

PURNEAH, a district forming the north-west division of Bengal. It is extremely fertile and well watered, producing remarkably fine cattle. It exports a great quantity of clarified butter, and is also celebrated for its sugar and indigo. The cattle are much used in the army, and for agricultural purposes: the northern mountains also produce valuable timber, which is cut in the hot weather, and afterwards floated down the rivers. It is supposed to contain nearly 1,500,000 of inhabitants, about one-third of whom are Mahometans. In 1722 the nabob Sief Khan, a friend of Cooly Jaffer Khan, was governor of Purneah, and had permission to conquer from the bordering rajahs as much territory as he could, which was to be exempt from any increase of revenue to the state. He made therefore very considerable additions to the district; and, while other parts of Bengal were overrun by the Mahrattas, Purneah continued in a state of tranquillity and prosperity. In May 1760 Khadem Hussein, then in possession of this district, endeavoured to cut off a British detachment under the command of captain Knox, but after an engagement of six hours was repulsed. On the 25th of June he again encountered the British forces, and was defeated. At the peace this chief was compelled to retire to Oude, from which period Purneah has become a district of Bengal. Its principal towns are Purneah and Tajepore, its former capital was Decote.

PURNEAH, the capital of the above district, is pleasantly situated on the eastern bank of the Seraw, and carries on a considerable trade. It is the residence of a judge, collector, &c. Long. 88° 23' E., lat. 25° 45' N.

PURPARTY, *n. s.* French *pour* and *parti*. Share; part in division.

Each of the coparceners had an entire county allotted for her *purparty*.

Davies on Ireland.

**PURPLE**, *v. a., n. s. & adj.* Fr. *pourpre*; Lat. *purpureus*. Red tinged with blue: a color among the ancients considered as the noblest, and as the regal color: to make purple: the color; a purple dress.

The poop was beaten good,  
Purple the sails, and so perfumed, that  
The winds were love-sick with 'em.

*Shakspeare.*

Whilst your purpled hands do reek and smok,  
Fulfil your pleasure.

*Id. Julius Cæsar.*

Cruel and suddain, hast thou since  
Purpled thy nail in blood of innocence?

*Donne.*

Your violets, that first appear,  
By your pure purple mantles known;  
What are you when the rose is blown?

*Wotton.*

Not alone, while thou  
Visit'st my slumbers nightly; or when morn  
Purple the East.

*Milton's Paradise Lost.*

O'er his lucid arms  
A vest of military purple flow'd  
Livelier than Melibœan, or the grain  
Of Sarra, worn by kings and heroes old.

*Milton.*

I could change the color, and make it purple.

*Boyle.*

I view a field of blood,  
And Tyber rolling with a purple flood.

*Dryden.*

Aurora had but newly chased the night,  
And purpled o'er the sky with blushing light.

*Id.*

May be it has been sometimes thought harsh in those who were born in purple to look into abuses with a stricter eye than their predecessors; but elected kings are presumed to come upon the foot of reformation.

*Davenant.*

A small oval plate, cut off a flinty pebble, and polished, is prettily variegated with a pale grey, blue, yellow, and purple.

*Woodward.*

Reclining soft in blissful bowers,  
Purpled sweet with springing flowers.

*Fenton.*

Not with more glories in the ethereal plain,  
The sun first rises o'er the purpled main.

*Pope.*

Their mangled limbs

Crash! g at once, death dyes the purple seas  
With gore.

*Thomson's Summer.*

**PURPLE.** See COLOR-MAKING, and DYEING.

**PURPORT**, *n. s. & v. a.*

**PURPOSE**, *n. s., v. a. & v. n.*

**PURPOSELY**, *adv.*

Fr. *pourporte*; } of Lat. *pro* and  
} *porto*. Design; }  
tendency of a writing or discourse: to intend: purpose, the intention, design, or thing, intended; effect; consequence; instance: to purpose as a verb active is, to intend; design: as a verb neuter to have a design: purpose, by design.

I am purposed that my mouth shall not transgress.

*Psalm xvii.*

This is the purpose that is purposed upon the whole earth.

*Isiah.*

What David did purpose, it was the pleasure of God that Solomon his son should perform.

*Hooker.*

Being the instrument which God hath purposefully framed, thereby to work the knowledge of salvation in the hearts of men, what cause is there wherefore it should not be acknowledged a most apt mean?

*Id.*

He with troops of horsemen beset the passages of purpose, that, when the army should set forward, he might in the straits, fit for his purpose, set upon them.

*Knolles.*

He quit the house of purpose, that their punishment  
Might have the freer course.

*Shakspeare. King Lear.*

Change this purpose,

Which being so horrible, so bloody, must

Lead on to some foul issue

*Shakspeare.*

It is a purposed thing, and grows by plot,

To curb the nobility.

*Id. Coriolanus.*

There was an article against the reception of the rebels, purporting that if any such rebel should be required of the prince confederate, that the prince confederate should command him to avoid the country.

*Bacon's Henry VII.*

The ground will be like a wood, which keepeth out the sun, and so continueth the wet, whereby it will never graze to purpose that year.

*Bacon.*

The first purpose to sin opens the gates to Satan.

*Bp. Hall.*

That kind of certainty which doth not admit of any doubt, may serve us as well to all intents and purposes as that which is infallible.

*Wilkins.*

And I persuade me God hath not permitted

His strength again to grow, were not his purpose

To use him farther yet.

*Milton's Agonistes.*

The whole included race his purposed prey.

*Milton.*

Oaths were not purposed more than law,

To keep the good and just in awe,

But to confine the bad and sinful,

Like moral cattle in a pinfold.

*Hudibras.*

Their design is a war, whenever they can open it with a prospect of succeeding to purpose.

*Temple.*

They, who are desirous of a name in painting, should read and make observations of such things as they find for their purpose.

*Dryden's Dufresnoy.*

'Tis common for double-dealers to be taken in their own snares, as for the purpose in the matter of power.

*L'Estrange.*

Such first principles will serve us to very little purpose, and we shall be as much at a loss with, as without them, if they may, by any human power, such as is the will of our teachers, or opinions of our companions, be altered or lost in us.

*Locke.*

That Plato intended nothing less is evident from the whole scope and purport of that dialogue.

*Norris.*

He travelled the world, on purpose to converse with the most learned men.

*Guardian.*

St. Austin hath laid down a rule to this very purpose.

*Burnet.*

They in most grave and solemn wise unfolded Matter, which little purposed, but words

Ranked in right learned phrase.

*Roué.*

I have purposefully avoided to speak any thing concerning the treatment due to such persons.

*Addison.*

Doubling my crime, I promise and deceive,

Purpose to slay, whilst swearing to forgive.

*Prior.*

He that would relish success to purpose, should keep his passion cool, and his expectation low.

*Collier on Desire.*

In composing this discourse, I purposefully declined all offensive and displeasing truths.

*Atterbury.*

The vulgar thus through imitation err,

As oft the learned by being singular;

So much they scorn the crown, that if the throng,

By chance go right, they purposefully go wrong.

*Pope.*

Where men err against this method, it is usually on purpose, and to shew their learning.

*Swift.*

I do this on purpose to give you a more sensible impression of the imperfection of your knowledge.

*Watts.*

What the Romans have done is not worth notice, having had little occasion to make use of this art, and what they have of it to *purpose* being borrowed from Aristotle.

*Baker.*

**PUR'PRISE**, *n. s.* Old Fr. *pourpris*; law Lat. *purpurisum, prensus*. A close or enclosure; the whole compass of a manor.

The place of justice is hallowed; and therefore not only the bench but the foot-pace and precincts, and *purprise* ought to be preserved without corruption.

*Bacon's Essays.*

**PURPURA**, in natural history. See **MUREX**.

**PURPURIC ACID**, in chemistry, acidum purpuricum: so called from its fine red color. The excrements of the serpent boa constrictor consist of pure lithic acid. Dr. Prout found that on digesting this substance thus obtained, or from urinary calculi, in dilute nitric acid, an effervescence takes place, and the lithic acid is dissolved, forming a beautiful purple liquid. The excess of nitric acid being neutralised with ammonia, and the whole concentrated by slow evaporation, the color of the solution becomes of a deeper purple; and dark red granular crystals, sometimes of a greenish hue externally, soon begin to separate in abundance. These crystals are a compound of ammonia with the acid principle in question. The ammonia was displaced by digesting the salt in a solution of caustic potassa, till the red color entirely disappeared. This alkaline solution was then gradually dropped into dilute sulphuric acid, which, uniting with the potassa, left the acid principle in a state of purity.

This acid principle is likewise produced from lithic acid by chlorine, and also, but with more difficulty, by iodine. Dr. Prout, the discoverer of this new acid, has, at the suggestion of Dr. Wollaston, called it purpuric acid, because its saline compounds have for the most part a red or purple color.

This acid, as obtained by the preceding process, usually exists in the form of a very fine powder, of a slightly yellowish or cream color; and when examined with a magnifier, especially under water, appears to possess a pearly lustre. It has no smell, nor taste. Its specific gravity is considerably above water. It is scarcely soluble in water. One-tenth of a grain, boiled for a considerable time in 1000 grains of water, was not entirely dissolved. The water, however, assumed a purple tint, probably, Dr. Prout thinks, from the formation of a little purpurate of ammonia. Purpuric acid is insoluble in alcohol and ether. The mineral acids dissolve it only when they are concentrated.

**PURR**, *v. a.* Teut. *murren*. To murmur as a cat or leopard; both words probably from the sound.

Tray fast asleep, and puss a *purring*,  
All silent, not a murmur stirring. *Fire Side.*

**PURRURY**, a town and district of the province of Gundwanah and Hindostan, the residence of a Burdy chief, who is a tributary of Singrowla rajah. The town is large, but the country poor, and largely covered with forests.

**PURSE**, *n. s. & v. a.* } Fr. *bourse*; Italian  
**PURSE'NET**, } *borsa*; barb. Lat *bursa*;  
**PURSE'PROUD**, *adj.* } Wel. *puers*. A small

bag in which money is contained: a net closed by a string, like a purse: to put into, or contract as, a purse; purse-proud is, puffed up with riches.

He sent certain of the chief prisoners, richly apparelled, with their *purses* full of money, into the city.

*Knolles.*

She bears the *purse* too; she is a region in Guiana, all gold and bounty.

*Shakspeare. Merry Wives of Windsor.*

Thou cried'st,

And didst contract and *purse* thy brow together,  
As if thou then had'st shut up in thy brain  
Some horrible conceit.

*Id. Othello.*

The illiberality of parents, in allowance towards their children, is a harmful error, and makes them base; acquaints them with shifts; makes them sort with mean company; and makes them surfeit more when they come to plenty: and therefore the proof is best when men keep their authority towards their children, but not their *purse*.

*Lord Bacon.*

I *purged* it up, but little reck'ning made,  
Till now, that this extremity compelled,  
I find it true.

*Milton.*

I am spell-caught by Philidel,  
And *purged* within a net.

*Dryden.*

Conies are taken by *pursetets* in their burrows.

*Mortimer.*

I will give him the thousand pieces, and, to his great surprise, present him with another *purse* of the same value.

*Addison.*

He was desirous of visiting Trent while the council was sitting; but the scantiness of his *purse* defeated his curiosity.

*Johnson.*

A **PURSER** is an officer aboard a man of war, who receives her victuals from the victualler, sees that it be well stowed, and keeps an account of what he every day delivers to the steward. He also keeps a list of the ship's company, and sets down exactly the day of each man's admission, in order to regulate the quantity of provisions to be delivered out, and that the paymaster or treasurer of the navy may issue out the disbursements, and pay off the men, according to his men.

The purser is charged with the clothes and effects of persons who die on board; and he sells the same before the mast to the rest of the crew, and is obliged to give a satisfactory account of the same to the executors or administrators of the deceased. It is his duty also to keep a regular sloop-book, wherein he is to make distinct and separate entries of the particulars and value of the sloop-clothes, bedding, dead men's clothes, &c., issued or supplied to the ship's company.

**PURSLAIN**, *n. s.* Lat. *portulaca*. A plant.

The medicaments, proper to diminish the milk, are lettuce, *purslain*, and endive. *Wiseman's Surgery.*

**PURSUÉ**, *v. n. & v. a.* } Fr. *poursuivre*;

**PURSU'ABLE**, } Lat. *prosequor*. To

**PURSU'ANT**, } follow; chase; fol-

**PURSU'ER**, *n. s.* } low hostilely; imi-

**PURSU'IT**, } tate; copy: as a

verb active, proceed: to go on: pursuable is that may be pursued: pursuant, done in consequence or prosecution of (a legal term): pursuer, he or she who follows, particularly with hostility: pursuit, the act of following; prosecution; endeavour; attempt made.

When Abraham heard that his brother was taken captive, he armed his trained servants, and pursued.

*Genesis xiv. 14.*

As righteousness tendeth to life; so he that pursueth evil, pursueth it to his own death. *Proverbs.*  
Love like a shadow flies, when substance love pursues;

Pursuing that that flies, and flying what pursues. *Shakspeare.*

Fled with the rest,  
And falling from a hill, he was so bruised,  
That the pursuers took him. *Id. Henry IV.*  
Like a declining statesman left forlorn  
To his friends' pity and pursuers' scorn.

*Denham.*

He concluded with sighs and tears, to conjure them, that they would no more press him to give his consent to a thing so contrary to his reason, the execution whereof would break his heart, and that they would give over further pursuit of it.

*Clarendon.*

Insatiate to pursue  
Vain war with heaven. *Milton.*

His swift pursuers from heaven's gates discern  
The advantage, and descending tread us down  
Thus drooping. *Milton's Paradise Lost.*

Arm, warriors, arm for fight! the foe at hand,  
Whom fled we thought, will save us long pursuit.

*Milton.*

I have, pursued Carneades, wondered chymists  
Should not consider.

*Boyle.*

I will pursue  
This ancient story, whether false or true.

*Dryden.*

This means they long proposed, but little gained,  
Yet, after much pursuit, at length obtained. *Id.*

When men pursue their thoughts of space, they stop at the confines of body, as if space were there at an end.

*Locke.*

He has annexed a secret pleasure to the idea of any thing that is new or uncommon, that he might encourage us in the pursuit after knowledge, and engage us to search into the wonders of his creation.

*Addison.*

We happiness pursue; we fly from pain;  
Yet the pursuit, and yet the flight is vain.

*Prior.*

Its honours and vanities are continually passing before him, and inviting his pursuit.

*Rogers.*

What nature has denied foads will pursue,  
As apes are ever walking upon two.

*Young.*

PURSUIVANT, *n. s.* Fr. *poursuivant*. A state messenger; an attendant on the heralds.

How oft do they with golden pinions cleave  
The fitting skies, like flying pursuivants!

Send out a pursuivant at arms  
To Stanley's regiment; bid him bring his power  
Before sun-rising.

*Shakspeare.*

For helmets, crests, mantles, and supporters, I leave the reader to Edmond Bolton, Gerard Leigh, John Ferne, and John Guillim Portsmouth, pursuivants of arms, who have diligently laboured in armory.

*Camden.*

The pursuivants came next,  
And like the heralds each his scutcheon bore.

*Dryden.*

PURSUIVANT, in heraldry, is the lowest order of officers at arms. They are properly attendants on the heralds when they marshal public ceremonies. Of these in England there were formerly many; but at present there are only four, viz. blue-mantle, rouge-cross, rouge-dragon, and port-cullice. In Scotland there is only one

king; at arms, who is styled Lyon; and has under him six heralds, and as many pursuivants.

PURSY, *adj.* Fr. *poussif*; Ital. *pulsivo*; of Lat. *pulsus*. Short-breathed and fat.

Now breathless Wrong  
Shall sit and pant in your great chairs for ease,  
And porsy Insolence shall break his wind  
With fear and horrid flight.

*Shakspeare*

An hostess dowager,  
Grown fat and porsy by retail  
Of pots of beer and bottled ale.

*Hudibras.*

By these, the Medes  
Perfume their breaths, and cure old porsy men.

*Temple.*

PURTENANCE, *n. s.* Fr. *apertenance*. The pluck of an animal.

Roast the lamb with fire, his head with his legs,  
and with the pertenance thereof.

*Escolus*

The shaft against a rib did glance,  
And galled him in the pertenance.

*Hudibras.*

PURVES (James), a learned Arian preacher, born at a little village of Berwickshire, in 1734 His father was only a keeper of cattle, and intended James for the same profession. He meanwhile, having obtained the loan of some books on mathematics, made himself master of geometry and trigonometry, and afterwards taught these sciences with other branches of mathematics, and assisted some public authors in compiling mathematical works, which have been well received. He joined a party of the ancient Cameronians, and in 1769, at one of their general meetings, was called to be a pastor among them. To qualify himself for this office he studied the Greek and Hebrew languages, and compiled a Hebrew Grammar, which is still in MS. These acquisitions led him into the study of the Arian Controversy, when he finally adopted the opinions of Arius; and afterwards became preacher to a small Arian congregation in Edinburgh; where he also kept a school and a book shop, for many years before he died. His works are, 1. A Humble Attempt to investigate the Scripture doctrine of the Trinity. 2. Observations on Prophetic Times, 2 vols. 3. A Treatise on Civil Government. 4. Observations on Socinian Arguments. 5. A Scriptural Catechism. 6. Correspondence with the Buchananites. 7. Dissertation on the Seals, Trumpets, &c. 8. Enquiry into the Nature of Faith and Regeneration. 9. Review of Paine's Age of Reason. 10. A Treatise on Sacrifices. 11. Review of some Religious Opinions, established by the Powers of the World, favorable to Despotism. 12. An Historic and Prophetic Representation of Events. 13. Scheme of the Lives of the Patriarchs. All these were published at Edinburgh within the last twelve years of his life, and evidence at least uncommon industry. He was three times married, and left a daughter by each wife. He died in 1789.

PURVEY, *v. a. & v. n.* Fr. *pourvoir*; Lat. *purveyance*, *n. s.* } *provisus*. To provide with conveniences; a sense not now in use: procure; buy in provisions: purveyance is provision; or the procurement or exaction of it: purveyor, he who procures victuals; a procurer of any kind: purview, proviso; providing clause.

PURVEYOR, }  
PURVIEW. }  
not now in use: procure; buy in provisions: purveyance is provision; or the procurement or exaction of it: purveyor, he who procures victuals; a procurer of any kind: purview, proviso; providing clause.

Give no odds to your foes, but do *purvey*  
Yourself of sword before that bloody day.

*Spenser.*

Whence, mounting up, they find *purveyance* meet  
Of all that princes royal court became.

*Id.*

The *purveys* or victuallers are much to be con-  
demned, as not a little faulty in that behalf.

*Raleigh.*

Some lands be more changeable than others; as  
for their lying near to the borders, or because of  
great and continual *purveyances* that are made upon  
them.

*Bacon.*

I the praise

Yield thee, so well this day thou hast *purveyed*.

*Milton.*

Though the petition expresses only treason and  
felony, yet the act is general against all appeals in  
parliament; and many times the *purview* of an act is  
larger than the preamble of the petition.

*Hale.*

His house with all convenience was *purveyed*,

The rest he found.

*Dryden.*

These women are such cunning *purveyors*!

Mark where their appetites have once been pleased,  
The same resemblance in a younger lover  
Lies brooding in their fancies the same pleasures.

*Id.*

The stranger, ravished at his good fortune, is in-  
troduced to some imaginary title; for this *purveyor*  
has her representatives of some of the finest ladies.

*Addison.*

What though from outmost land and sea *purveyed*,  
For him each rarer tributary life

Bleeds not.

*Thomson.*

And winged *purveyors* his sharp hunger fed

With frugal scraps of flesh, and maslin bread.

*Harte.*

**PURULENT, *adj.*** Fr. *purulent*; Lat. *puru-  
lentus*. Consisting of pus or the running matter  
of wounds.

A carcase of man is most infectious and odious to  
man, and *purulent* matter of wounds to sound flesh.

*Bacon.*

Nothing could be more proper, for the ripening of  
hard and *purulent* tumors, than dry figs.

*Bp. Hall.*

It is no easy thing always to discern, whether the  
suspected matter expectorated by a cough be really  
*purulent*, that is, such as comes from an ulcer.

*Blackmore.*

An acrimonious or *purulent* matter, stagnating in  
some organ, is more easily deposited upon the liver  
than any other part.

*Arbuthnot.*

It spews a filthy froth

Of matter *purulent* and white,

Which happened on the skin to light,

And there corrupting on a wound,

Spreads leprosy.

*Swift.*

**PUS, *n. s.*** Lat. *pus*. Corrupt animal matter;  
matter of a sore.

Acrid substances break the vessels, and produce  
an ichor instead of laudable *pus*.

*Arbuthnot.*

*Pus*, in medicine and surgery. See SUR-  
GERY.

**PUSH, *v. a., v. n. & n. s.*** Fr. *pousser*; of Lat.  
*pulso, pello*. To strike in the manner of a thrust;  
drive; impel; force; urge; make a thrust,  
effort, or attack: as a noun substantive, the ef-  
fort; thrust; attack made; exigence; trial;  
emergence.

If the ox *push* a man-servant, he shall be stoned.

*Exodus.*

Through thee will we *push* down our enemies.

*Psalms.*

The king of the south shall *push* at him, and the  
king of the north shall come against him. *Daniel.*

Ne might his corse be harmed

With dint of sword or *push* of pointed spear.

*Spenser.*

They, like resolute men, stood in the face of the  
breach, receiving them with deadly shot and *push* of  
pike, in such furious manner, that the Turks began  
to retire.

*Knolles.*

Shew your mended faiths,

To *push* destruction and perpetual shame

Out of the weak door of our fainting land.

*Shakspeare.*

He gave his countenance against his name,

To laugh with gybing boys, and stand the *push*

Of every beardless vain comparative.

*Id.*

We'll put the matter to the present *push*.

*Id.*

He that was praised to his hurt should have a *push*  
rise upon his nose; as a blister will rise upon one's  
tongue, that tells a lye.

*Bacon.*

Waters forcing way,

Sidelong had *pushed* a mountain from his seat,

Half sunk with all his pines.

*Milton.*

He forewarns his care

With rules to *push* his fortune or to bear.

*Dryden.*

Arts and sciences, in one and the same century,  
have arrived at great perfection, and no wonder,  
since every age has a kind of universal genius, which  
inclines those that live in it to some particular stu-  
dies; the work then being *pushed* on by many hands,  
must go forward.

*Id.*

Away he goes, makes his *push*, stands the shock  
of a battle, and compounds for leaving of a leg be-  
hind him.

*L'Estrange.*

'Tis common to talk of dying for a friend; but,  
when it comes to the *push*, 'tis no more than talk.

*Id.*

A calf will so manage his head as though he  
would *push* with his horns even before they shoot.

*Ray.*

Ambition *pushes* the soul to such actions as are  
apt to procure honour to the actor.

*Spectator.*

Lambs, though they never saw the actions of their  
species, *push* with their foreheads, before the budding  
of a horn.

*Addison.*

Jove was not more pleased

With infant nature, when his spacious hand

Had rounded this huge ball of earth and seas,

To give it the first *push*, and see it roll

Along the vast abyss.

*Id.*

The question we would put is not whether the  
sacrament of the mass be as truly propitiatory as  
those under the law? but whether it be as truly a  
sacrifice? if so, then it is a true proper sacrifice, and  
is not only commemorative or representative, as we  
are told at a *push*.

*Atterbury.*

This terrible scene which might have proved dan-  
gerous, if Cornelius had not been *pushed* out of the  
room.

*Arbuthnot.*

We are *pushed* for an answer, and are forced at  
last freely to confess, that the corruptions of the  
administration were intolerable.

*Swift.*

When such a resistance is made, these bold talkers  
will draw in their horns, when their fierce and feeble  
*pushes* against truth are repelled with *pushing* and  
confidence.

*Watts.*

**PUSILLANIMITY, *n. s.*** Fr. *pusillani-*

**PUSILLANIMOUS, *adj.*** *mité*; Lat. *pusil-  
lus* and *animus*. Cowardice; meanness of spirit;  
the adjective corresponding.

The property of your excellent sherris is the warm-  
ing of the blood, which, before cold and settled, left  
the liver white and pale, the badge of *pusillanimity*  
and cowardice.

*Shakspeare.*

The Chinese sail where they will, which sheweth that their law of keeping out strangers is a law of *pusillanimity* and fear. *Bacon.*

An argument fit for great princes, that neither by overmeasuring their forces they lose themselves in vain enterprizes; nor, by undervaluing them, descend to fearful and *pusillanimous* counsels. *Bacon.*

What greater instance can there be of a weak *pusillanimous* temper, than for a man to pass his whole life in opposition to his own sentiments? *Spectator.*

It is obvious, to distinguish between an act of courage and an act of rashness, an act of *pusillanimity*, and an act of great modesty or humility. *South.*

He became *pusillanimous*, and was easily ruffled with every little passion within; supine, and as openly exposed to any temptation from without. *Woodward's Natural History.*

**PUSS**, *n. s.* Lat. *pusio*, a dwarf, Johnson conjectures; but Belg. *poes*, is a cat. The fondling name of a cat.

A young fellow, in love with a cat, made it his humble suit to Venus to turn *pus* into a woman. *L'Estrange.*

Poor honest *pus*,

It grieves my heart to see thee thus;

But hounds eat sheep as well as hares. *Gay.*

I will permit my son to play at apodidascinda, which can be no other than our *pus* in a corner. *Arbutnot and Pope.*

Let *pus* practise what nature teaches. *Watts.*

*Pus* grew presently familiar, and would leap into my lap. *Cowper.*

**PUSTERHAL**, a mountainous district of the Austrian states, in the Tyrol, on the borders of Carinthia, fifty miles long by eighteen broad. Its chief product is flax, and the manufactures linen and lace. It abounds in metallic ores, rock crystal, mineral waters, and warm baths. The population is 80,000, and the chief town Lienz.

**PUSTULE**, *n. s.* Fr. *pustule*; Lat. *pustula*. A small swelling; a pimple.

The blood, turning acrimonious, corrodes the vessels, producing hemorrhages, *pustules*, red, black, and gangrenous. *Arbutnot.*

**PUT**, *v. a., v. n. & n. s.* Dan. *putten*, 'to plant,' says Junius; but Lat. *posito*, and Ital. *postare* and *potta*, seem a more natural etymology. To place; deposit; repose; trust; apply; use actively; oblige; urge; hence cause; produce; consign, especially to writing; incite; instigate (taking *upon*); propose; state; offer; place as an ingredient: this word takes a variety of prepositions, as *by, down, forth, in, off, on, upon, &c.*; but explained in their actual use: as a verb neuter, to put, is to go, or move; steer a vessel; germinate; shoot; taking *forth, in, in for, off, over, &c.*: as a noun substantive, put, is an action or signal of distress: hence, perhaps, a rustic; low person; and an excuse; theft; as is a *put-off*.

And alle men that herden *puttiden* in her herte, and seiden what manner child schal this be, for the bond of the Lord was with him. *Wicliff Luk. i.*

God planted a garden, and there he *put* man. *Gen. ii. 8.*

He *put* forth his hand and pulled her in. *Id. viii. 9.*

If God be with me, and give me bread to eat, and raiment to *put on*, then shall the Lord be my God. *Id. xxviii. 20.*

When she travailed, the one *put out* his hand. *Genesis.*

If a man *put* in his beast, and feed in another man's field; of the best of his own shall he make restitution. *Exod. xxii. 5.*

Rejoice before the Lord in all that thou *puttest* thine hands unto. *Deut. xii. 18.*

She shall be his wife, he may not *put* her away. *Id. xxii.*

Samson said, I will now *put forth* a riddle unto you. *Judges.*

The Philistines *put out* his eyes. *Id. xvii.*

How wilt thou *put* thy trust on Egypt for chariots? *2 Kings.*

Cyrus made proclamation, and *put* it also in writing. *2 Chronicles.*

The king of Egypt *put* Jehoahaz down at Jerusalem. *Id.*

None of us *put off* our cloaths, saying that every one *put* them off for a washing. *Nehem. iv. 23.*

Whatsoever God doeth, nothing can be *put* to it, nor any thing taken from it. *Eccles. iii. 14.*

The fig-tree *putteth forth* her green figs. *Canticles ii. 13.*

When he had *put* them all out he entereth in. *Mark v. 40.*

As we were *put* in trust with the gospel, even so we speak, not as pleasing men, but God. *1 Thess.*

Basilus, in his old years, marrying a young and fair lady, had of her those two daughters so famous in beauty, which *put* by their young cousin from that expectation. *Sidney.*

The greedy thirst of royal crown  
Stirred Porrex up to *put* his brother down. *Spenser.*

The Turks were in every place *put* to the worst, and lay by heaps slain. *Knolles's History of the Turks.*

Taking his cap from his head, he said, this cap will not hold two heads, and therefore it must be fitted to one, and so *put* it on again. *Knolles.*

The carpenters being set to work, and every one *putting* to his helping hand, the bridge was repaired. *Id.*

Before we will lay by our just born arms,  
We'll *put* thee down, gainst whom these arms we bear, *Shakspeare.*

Or add a royal number to the dead. *Id.*

I do but keep the peace, *put up* thy sword. *Id.*

This dishonours you no more,  
Than to take in a town with gentle words,  
Which else would *put* you to your fortune. *Id.*

Was the crown offered him thrice?  
—Ay, marry, was't, and he *put* it by thrice,  
Every time gentler than other. *Id.*

Mark now how a plain tale shall *put* you down. *Id.*

Upon these taxations,  
The clothiers all *put off*  
The spinsters, carders, fullers, weavers. *Id.*

Strangely visited people he cures,  
Hanging a golden stamp about their necks,  
*Put on* with holy prayers. *Id. Macbeth.*

So shall inferior eyes,  
That borrow their behaviour from the great,  
Grow great by your example, and *put on*  
The dauntless spirit of resolution. *Shakspeare.*

For the certain knowledge of that truth,  
I *put* you o'er to heaven, and to my mother. *Id.*

From Ireland am I come,  
To signify that rebels there are up,  
And *put* the Englishmen unto the sword. *Id.*

They have a leader,  
Tullus Aufidius, that will *put* you to't. *Id.*

Why so earnestly seek you to *put up* that letter. *Id.*

When in swinish sleep,  
 What cannot you and I perform upon  
 The' unguarded Duncan? what not *put upon*  
 His spungy officers, who shall bear the guilt  
 Of our great quell? *Id. Macbeth.*  
 Orders for sea are given;  
 They have *put forth* the haven. *Shakspeare.*  
 My good lord cardinal, they vent reproaches  
 Most bitterly on you, as *putter on*  
 Of these exactions. *Id. Henry VIII.*  
 They shall stand for seed! they had gone down  
 too, but that a wise burgher *put in* for them.  
*Shakspeare.*  
 Whatsoever cannot be digested by the stomach is  
 by the stomach either *put up* by vomit, or *put down*  
 to the guts. *Bacon.*  
 Those that *put* their bodies to endure in health,  
 nay, in most sicknesses, be cured only with diet and  
 tendering. *Id.*  
 An excellent observation of Aristotle, why some  
 plants are of greater age than living creatures, for  
 that they yearly *put forth* new leaves; whereas living  
 creatures *put forth*, after their period of growth, no-  
 thing but hair and nails, which are excrements. *Id.*  
 It is the new skin or shell that *putteth off* the old;  
 so we see, that it is the young horn that *putteth off*  
 the old. *Id.*  
 This came handsomely to *put on* the peace, be-  
 cause it was a fair example of a peace bought.  
*Id. Henry VII.*  
 Wheresoever the wax floated, the flame forsook it,  
 till at last it spread all over, and *put* the flame quite  
 out. *Bacon.*  
 The nobility of Castile *put out* the king of Arra-  
 gon, in favour of king Philip. *Id. Henry VII.*  
 There were no barks to throw the rebels into, and  
 send them away by sea, they were *put all* to the  
 sword. *Bacon.*  
 Having lost two of their bravest commanders at  
 sea, they durst not *put it* to a battle at sea, and set  
 up their rest wholly upon the land enterprize. *Id.*  
 It is to be *put* to question in general, whether it  
 be lawful for Christian princes to make an invasive  
 war, simply for the propagation of the faith. *Id.*  
 The wind cannot be perceived, until there be an  
 eruption of a great quantity from under the water;  
 whereas, in the first *putting up*, it cooleth in little  
 portions. *Id.*  
 It is manifest that the duke did his best to come  
 down, and to *put* to sea. *Id.*  
 One Bell was *put* to death at Tyburn for moving  
 a new rebellion. *Hugward.*  
 No ties,  
 Halsers, or gables need, nor anchor cast,  
 Whom storms *put in* there, are with stay embraced.  
*Chapman.*  
 I boarded and commanded to ascend  
 My friends and soldiers, to *put off* and lend  
 Way to our ship. *Id.*  
 Ambition, like a torrent, ne'er looks back;  
 And is a swelling, and the last affection  
 A high mind can *put off*. *Ben Jonson's Catiline.*  
 Others envy to the state draws, and *puts on*  
 For contumelies received. *Id.*  
 Sir Francis Drake came coasting along from Car-  
 thageua, a city of the mainland to which he *put over*,  
 and took it. *Akhot.*  
 Himself never *put up* any of the rent, but dis-  
 posed of it by the assistance of a reverend divine to  
 augment the vicar's portion. *Spelman.*  
 Avarice *puts on* the canonical habit.  
*Decay of Piety.*  
 A nimbler fencer will *put in* a thrust so quick that  
 the foil will be in your bosom, when you thought it  
 a yard off. *Digby.*

Jonathan had died for being so,  
 Had not just God *put by* the' unnatural blow.  
*Cowley.*  
 It *puts* a man from all employment, and makes a  
 man's discourses tedious. *Taylor's Holy Living.*  
 In honouring God, *put forth* all thy strength.  
*Taylor.*  
 Such as were taken on either side, were *put to* the  
 sword or to the halter. *Clarendon.*  
 The great preparation *put* the king upon the reso-  
 lution of having such a body in his way. *Id.*  
 Four speedy cherubims  
 Put to their mouths the sounding alchemy.  
*Milton.*  
 This question asked *puts* me in doubt. *Id.*  
 I *put* not forth my goodness. *Id.*  
 I for his sake will leave  
 Thy bosom, and this glory next to thee  
 Freely *put off*, and for him lastly die. *Id.*  
 I must die  
 Betrayed, captived, and both my eyes *put out*. *Id.*  
 He said, let the earth  
 Put forth the verdant grass, herb yielding seed,  
 And fruit tree yielding fruit. *Id.*  
 In these he *put* two weights. *Id.*  
 When the wisest council of men have with the  
 greatest prudence made laws, yet frequent emer-  
 gencies happen which they did not foresee, and there-  
 fore they are *put upon* repeals and supplements of  
 such their laws; but Almighty God, by one simple  
 foresight, foresaw all events, and could therefore fit  
 laws proportionate to the things he made. *Hale.*  
 Soon as they had him at their mercy,  
 They *put* him to the cudgel fiercely. *Hudibras.*  
 Nor *put up* blow, but that which laid  
 Right worshipful on shoulder-blade. *Id.*  
 One hundred pounds only *put out* at interest, at  
 ten per cent, doth in seventy years increase to above  
 one hundred thousand pounds. *Child.*  
 Although astrologers may here *put in*, and plead the  
 secret influence of this star, yet Galen, in his com-  
 ment, makes no such consideration. *Browne.*  
 I do not intend to be thus *put off* with an old  
 song. *More.*  
 The discourse I mentioned was written to a pri-  
 vate friend, who *put* me upon that task. *Boyle.*  
 I hope for a demonstration, but Themistius hopes  
 to *put* me off with an harangue. *Id.*  
 The Canaanitish woman must *put up* a refusal, and  
 the reproachful name of a dog, commonly used by  
 the Jews of the heathen. *Id.*  
 We are *put* to prove things, which can hardly be  
 made plainer. *Tillotson.*  
 Those who have lived wickedly before, must  
 meet with a great deal more trouble, because they  
 are *put upon* changing the whole course of their life.  
*Id.*  
 To *put* your ladyship in mind of the advantages  
 you have in all these points, would look like a de-  
 sign to flatter you. *Temple*  
 So nature prompts; so soon we go astray,  
 When old experience *puts* us in the way.  
*Dryden.*  
 Put it thus—unfold to Statius straight,  
 What to Jove's ear thou didst impart of late:  
 He'll stare. *Id.*  
 I am as much ashamed to *put* a loose indigested  
 play upon the publick, as I should be to offer brass  
 money in a payment. *Id.*  
 When I drove a thrust, home as I could,  
 To reach his traitor heart, he *put* it by,  
 And cried, spare the stripling. *Id.*  
 Now the cheerful light her fears dispelled,  
 She with no winding turns the truth conceald,  
 But *put* the woman off, and stood reveal'd. *Id.*

With copper collars and with brawny backs,  
Quite to *put down* the fashion of our blacks. *Id.*  
You tell us that you shall be forced to leave off  
your modesty; you mean that little which is left;  
for it was worn to rags when you *put out* this medal.  
*Id.*

I was not more concerned in that debate  
Of empire, when our universal state  
Was *put to hazard*, and the giant race  
Our captive skies were ready to embrace. *Id.*  
He warned him for his safety to provide;  
Not *put to sea*, but safe on shore abide. *Id.*  
Some hard words the goat gave, but the fox *put*  
off all with a jest. *L'Estrange.*

The most wretched sort of people are dreamers  
upon events and *putters* of cases. *Id.*  
Mercury had a mind to learn what credit he had  
in the world, and so *put on* the shape of a man. *Id.*  
The stork found he was *put upon*, but set a good  
face however upon his entertainment. *Id.*

It is prudence in many cases, to *put up* the injuries  
of a weaker enemy, for fear of incurring the displea-  
sure of a stronger. *Id.*  
The stag's was a forced *put*, and a chance rather  
than a choice. *Id.*

The fox's *put off* is instructive towards the govern-  
ment of our lives, provided his fooling be made our  
earnest. *Id.*

Men may *put* government into what hands they  
please. *Locke.*

A sinew cracked seldom recovers its former strength,  
or the memory of it leaves a lasting caution in the  
man, not to *put* the part quickly again to robust em-  
ployment. *Id.*

A man, not having the power of his own life,  
cannot *put* himself under the absolute arbitrary  
power of another to take it. *Id.*

There is great variety in men's understanding;  
and their natural constitutions *put* so wide a differ-  
ence between some men, that industry would never  
be able to master. *Id.*

They should seldom be *put about* doing those  
things, but when they have a mind. *Id.*

He has right to *put into* his complex idea, signi-  
fied by the word gold, those qualities which upon  
trial he has found united. *Id.*

Fallacies we are apt to *put upon* ourselves, by  
taking words for things. *Id.*

Christ will bring all to life, and then they shall  
be *put* every one upon his own trial, and receive judg-  
ment. *Id.*

Feed land with beasts and horses, and after both  
*put in* sheep. *Mortimer's Husbandry.*

As for the time of *putting* the rams to the ewes,  
you must consider at what time your grass will  
maintain them. *Mortimer.*

A fright hath *put by* an ague fit, and mitigated a  
fit of the gout. *Grew's Cosmologia.*

I expect an offspring, docile and tractable in what-  
ever we *put* them to. *Tatler.*

This last age has made a greater progress than  
all ages before *put together*. *Burnet.*

Do men in good earnest think that God will be  
*put off* so? or that the law of God will be baffled  
with a lie clothed in a scoff? *South.*

I *put* the case at the worst, by supposing, what  
seldom happens, that a course of virtue makes us  
wiserable in this life. *Spectator.*

He replied, with some vehemence, that he would  
undertake to prove trade would be the ruin of the  
English nation; I would fain have *put* him upon it.  
*Addison.*

We should *put forth* all our strength, and, without  
having an eye to his preparations, make the greatest  
push we are able. *Id.*

My friend, fancying her to be an old woman of  
quality, *put off* his hat to her, when the person *pull-*  
ing off his mask appeared a smock-faced young  
fellow. *Id.*

An old usurer, charmed with the pleasures of a  
country life, in order to make a purchase, called in  
all his money; but, in a very few days after, *put it*  
out again. *Id.*

When I was at Venice, they were *putting out*  
curious stamps of the several edifices, most famous  
for their beauty or magnificence. *Id.*

I shall be hard *put to it*, to bring myself off. *Id.*  
Such national injuries are not to be *put up*, but  
when the offender is below resentment. *Id.*

An ordinary fleet could not hope to succeed  
against a place that has always a considerable num-  
ber of men of war ready to *put to sea*. *Id.*

This scrupulous way would make us deny our  
senses; for there is scarcely any thing but *puts* our  
reason to a stand. *Collier.*

If a man should *put in* to be one of the knights of  
Malta, he might modestly enough prove his six de-  
scents against a less qualified competitor. *Id.*

Queer country *puts* extol queen Bess's reign,  
And of lost hospitality complain. *Bramston.*

This *put me upon* observing the thickness of the  
glass, and considering whether the dimensions and  
proportions of the rings may be truly derived from it  
by computation. *Newton.*

It need not be any wonder why I should employ  
myself upon that study, or *put* others upon it.  
*Walker.*

He seems generally to prevail, persuading them  
to a confidence in some partial works of obedience,  
or else to *put off* the care of their salvation to some  
future opportunities. *Rogers.*

Wherever he *puts a slight upon* good works, 'tis as  
they stand distinct from faith. *Atterbury.*

Teuta *put to* death one of the Roman ambassadors;  
she was obliged, by a successful war which the Ro-  
mans made, to consent to give up all the sea coast.  
*Arbutnot.*

So many accidents may deprive us of our lives,  
that we can never say, that he who neglects to se-  
cure his salvation to-day, may without danger *put it*  
off till to-morrow. *Wake.*

We see the miserable shifts some men are *put to*,  
when that which was founded upon, and supported  
by idolatry, is become the sanctuary of atheism.  
*Bentley.*

If without any provocation gentlemen will fall upon  
one, in an affair wherein his interest and reputation  
are embarked, they cannot complain of being *put into*  
the number of his enemies. *Pope.*

As Homer went, the ship *put in* at Samos, where  
he continued the whole winter, singing at the houses  
of great men, with a train of boys after him. *Id.*

When men and women are mixed and well chosen,  
and *put* their best qualities forward, there may be  
any intercourse of civility and good will. *Swift.*

These wretches *put us upon* all mischief, to feed  
their lusts and extravagancies. *Id.*

I only *put* the question, whether in reason it  
would not have been proper the kingdom should have  
received timely notice? *Id.*

It is very hard that Mr. Steele should take up the  
artificial reports of his own faction, and then *put* them  
off upon the world as additional fears of a popish  
successor. *Id.*

There is no quality so contrary to any nature which  
one cannot affect, and *put on* upon occasion, in order  
to serve an interest. *Id.*

With this he *put up* to my lord,  
The courtiers kept their distance due,  
He twitched his sleeve. *Id.*



Homer says he *puts off* that air of grandeur which so properly belongs to his character, and debases himself into a droll.

*Broome.*

As danger did approach, her spirits rose,  
And *putting on* the king dismaysed her foes.

*Halliflar.*

**PUTAMINEÆ**, from *putamen*, a shell, the name of the twenty-fifth order of Linnæus's fragments of a natural method; consisting of a few genera of plants allied in habit, whose fleshy seed-vessel or fruit is frequently covered with a hard woody shell. See **BOTANY**.

**PUTATIVE**, *adj.* Fr. *putatif*, from Lat. *puto*. Supposed; reputed.

If a wife commits adultery, she shall lose her dowry, though she be only a *putative*, and not a true and real wife.

*Ayliffe.*

**PUTEANUS** (*Erycius*), LL. D., or *Erick Vandeput*, a learned professor, born at Venlo, in Guelderland, in 1574. He was educated at Dort, and studied rhetoric and philosophy at Cologne, in the Jesuits' college. He next studied law at Louvain, and in 1597 went to Padua and Milan; at which last city he was chosen professor of eloquence in 1601. He was made historiographer to the king of Spain; and in 1603 a patrician of Rome. In 1604 he became LL. D. at Milan, and married. In 1606 he was called to Louvain, appointed successor to Justus Lipsius, and governor of the castle. He published many works, amounting to 5 vols. folio; and died in 1646.

**PUTEOLI**, an ancient city of Italy, in Naples, and in the province of Campania, so called either from its wells, there being many hot and cold springs thereabouts; or from its stench, putor, caused by sulphureous exhalations. (*Livy, Varro, Strabo.*) In a very remote age the Cumæans made it their arsenal and dockyard; and to this naval establishment gave the sublime appellation of *Dicæarchea*, or just power. The Romans, sensible of the utility of this port, took great pains to improve its natural advantages. Nothing remains of their works but a line of piers, vulgarly called the bridge of Caligula. The ruins of its ancient edifices are widely spread along the adjacent hills and shores. An amphitheatre still exists entire in most of its parts, and a temple of Serapis. In the neighbourhood are many relics of ancient grandeur; particularly the Campanian way, paved with lava, and lined on each side with venerable towers, the repositories of the dead, which are richly adorned with stucco in the inside.

**PUTI CARAJA**, in botany, a genus of Indian plants: *CAL.* five cleft: *COR.* has five equal petals, the pericarp a thorny legumen and two seeds, the leaves oval and pinnated, and the stem armed: *SEEDS* very bitter, and tonic.

**PUTID**, *adj.* Let. *putidus*. Mean; low; worthless.

He that follows nature is never out of his way; whereas all imitation is *putid* and servile.

*L'Strange.*

**PUT-IN-BAY**, a bay in the south-west part of Lake Erie, formed by the island of Edward, ten miles W. N. W. of Sandusky Bay. It is open to the north, and well-sheltered. The entrance is not more than a quarter of a mile wide, having on the western side a narrow rocky

point, about forty feet high; where it joint the island the isthmus is so low as to be generally overflowed. From the point a block-house and strong battery defend the harbour, which has excellent anchorage.

**PUTIVL**, a town of the government of Kursk, European Russia, on the Sem. It is the chief place of a district or circle; has a number of churches, a monastery, and 9000 inhabitants, who carry on a traffic chiefly in woollens and sink. Here is also a manufactory of vitriol, and some brick-works. It is 120 miles W. S. W. of Kursk.

**PUTLOG**, *n. s.* From *put* and *log*. See the *extract*.

*Putlogs* are pieces of timber or short poles, about seven foot long, [*put*] to bear the boards they stand on to work, and to lay bricks and mortar upon.

*Moxon's Mechanical Exercises.*

**PUTNAM**, a town of Washington county, New York, twenty-eight miles north of Sandy Hill. Population 499. It lies on lake Champlain.

**PUTNAM**, a county of the west part of Georgia. Population upwards of 1000. Chief town Eaton Town.—Also a county of New York.

**PUTREFACTION**, *Fr.* *putride*; *Lat.* *putridus*. Rotten; corrupt; stinking: *putredinous* is an obsolete synonyme: *putrefaction* signifies the state of growing corrupt; rotten; or foul; act of making rotten: *putrefactive*, making rotten: to *putrefy*, to corrupt; make rotten: as a verb neuter, to rot: *putrescence*, the state of rotting; the adjective corresponding: *putridness*, rottenness.

From the sole of the foot, even unto the head, there is no soundness in it, but wounds and bruises, and *putrefying* sores.

*Isaiah i. 6.*

To keep them here,

They would but stink, and *putrefy* the air.

*Shakespeare.*

If the spirit protrude a little, and that motion be inordinate, there followeth *putrefaction*, which ever dissolveth the consistence of the body into much inequality.

*Bacon.*

Many ill projects are undertaken, and private suits *putrefy* the public good.

*Id.*

These hymns, though not revive, embalm and spice

The world, which else would *putrify* with vice.

*Donne.*

They make *putrefactive* generations conformable unto seminal productions. *Browne's Vulgar Errors.*

Now if any ground this effect from gall or cholor, because being the fiery humour, it will readiest surmount the water, we may confess in the common *putrescence*, it may promote elevation.

*Browne.*

The wine to *putrid* blood converted flows.

*Waller.*

A wound was so *putrified* as to endanger the bone.

*Temple.*

*Putrid fever* is that kind of fever in which the humours, or part of them, have so little circulatory motion that they fall into an intestine one, and *putrefy*, which is commonly the case after great evacuations, great or excessive heat.

*Quincy.*

*Putrefaction* is a kind of fermentation, or intestine motion of bodies, which tends to the destruction of that form of their existence which is said to be their natural state. *Id.*

All imperfect mixture is apt to *putrefy*, and watery substances are more apt to *putrefy* than oily.

*Woodward's Natural History.*

One of these knots rises to suppuration, and bursting excludes its *putrefaction*. *Blackmore.*

If a nurse feed only on flesh, and drink water, her milk, instead of turning sour, will turn *putrid*, and smell like urine. *Arbuthnot.*

Vegetable *putrefaction* is produced by throwing green vegetables in a heap in open warm air, and pressing them together, by which they acquire a *putrid* stercoraceous taste and odour. *Id.*

Such a constitution of the air, as would naturally *putrefy* raw flesh, must endanger by a mortification. *Id.*

Aliment is not only necessary for repairing the fluids and solids of an animal, but likewise to keep the fluids from the *putrescent* alkaline state which they would acquire by constant motion. *Id.*

If the bone be corrupted, the *putrefactive* smell will discover it. *Wiseeman's Surgery.*

The pain proceeded from some acrimony in the serum, which, falling into this declining part, *putrefies*. *Id.*

Nidorous ructus depend on the fetid spirituousity of the ferment, and the *putridness* of the meat. *Floyer on the Humours.*

*Floyer on the Humours.*

A *putredinous* ferment coagulates all humours, as milk with rennet is turned. *Id.*

'Tis such a light as *putrefaction* breeds  
In fly-blown flesh, whereon the maggot feeds,  
Shines in the dark, but, ushered into day,  
The stench remains, the lustre dies away. *Cowper.*

His limbs,  
With palsy shaken about him, blasted lie;  
And all his flesh is full of *putrid* sores  
And noisome wounds, his bones of racking pains:  
Strange vesture this for an immortal soul. *Pollok.*

PUTREFACTION is one of the natural processes by which organized bodies are dissolved, and reduced to what may be called their original elements. Putrefaction differs from chemical solution; because, in the latter, the dissolved bodies are kept in their state of solution by being combined with a certain agent from which they cannot easily be separated; but, in putrefaction, the agent which dissolves the body appears not to combine with it in any manner or way, but merely to separate the parts from each other. It differs also from the resolution of bodies by distillation with violent fire; because in distillation new and permanent compounds are formed, but by putrefaction every thing seems to be resolved into substances much more simple and indestructible than those which are the result of any chemical process. The bodies most liable to putrefaction are those of animals and vegetables, especially when full of juices. Stones, though by the action of the weather they will moulder into dust, yet seem not to be subject to any thing like real putrefaction, as they are not resolved into any other substance than sand, or small dust, which still preserves its lapideous nature. In like manner vegetables of any kind, when deprived of their juices by drying, may be preserved for many ages without being subjected to any thing like a putrefactive process. The parts of animals also, by simple drying, may be preserved in a

sound state for a much longer time than they could be without the previous exhalation of their juices.

Putrefaction is generally allowed to be a kind of fermentation, or rather to be the last stage of that process; which, beginning with the vinous fermentation, goes on through the acetous, to the stage of putridity, where it stops. In several respects, however, it differs so much from these processes, that it seems in some degree doubtful whether it can with propriety be called a fermentation or not. Both these vinous and acetous fermentations are attended with a considerable degree of heat: but in the putrefaction of animal matters especially, the heat is for the most part so small that we cannot be certain whether there is any degree of it or not produced by the process. A most remarkable difference is that the vinous fermentation produces ardent spirits, the acetous vinegar; but putrefaction produces nothing but earth, and some effluvia, which, though most disagreeable, and even poisonous to the human body, yet, being imbibed by the earth and vegetable creation, give life to a new race of beings. It is commonly supposed, indeed, that volatile alkali is a production of the putrefactive process; but this is disputed. The only thing in which the putrefactive fermentation agrees with the other kinds is, that in all the three there is an extrication of carbonic acid.

One reason why an animal body does not putrify while alive is its ventilation, as we may call it, by respiration; and another is the continual accession of new particles, less disposed to putrify than itself, by the food and drink which is constantly taken in. But, if either of these ways of preventing the commencement of this process be omitted, then putrefaction will take place as well in a living as in a dead body. Bodies will not putrify in vacuo, because there the atmosphere has not access to impart its elastic principle. If the body is very dry, putrefaction cannot take place, because the texture is too firm to be decomposed by the weak action of the elastic principle. Putrefaction may also be prevented by the addition of certain substances. Thus various kinds of salts and acids harden the texture of animal substances, and thus are successfully used as antiseptics. The same thing may be said of ardent spirits; while oils and gums of various kinds prove antiseptic by a total exclusion of air, which is necessary in some degree for carrying on the process of putrefaction. Many vegetables, by the astringent qualities they possess, harden the texture of animal substances, and thus prove powerfully antiseptic; while, on the other hand, fixed alkaline salts, quicklime, and caustic volatile alkali, though they prevent putrefaction, yet they do it by dissolving the substances in such a manner that putrefaction could do no more had it exerted its utmost force. Sugar, though neither acid nor alkaline, is yet one of the most effectual antiseptics known: and this seems to be owing to its great tendency to run into the vinous fermentation, which is totally inconsistent with that of putrefaction; and this tendency is so great that it can scarcely be counteracted by the tendency of animal substances to putrefy in any circumstances whatever.

In putrefaction the animal matter generally passes off in the gaseous form; and an inconsiderable quantity of earthy matter remains when the process is finished. The precise nature of these combinations has not, from the extreme offensiveness of the process, been accurately observed; and they probably vary according to the nature of the animal matter, and the circumstances under which it is decomposed. Ammonia, formed by the union of the azote and hydrogen of the animal matter, is always disengaged in considerable quantity. Phosphureted hydrogen is likewise produced; and this gas, even when obtained pure, has the odor exclusively termed putrid. Sulphureted hydrogen forms another part of the vapors disengaged from putrefying substances. Carbureted hydrogen and carbonic acid are likewise separated. And, lastly, it is probable that not only these binary combinations, but compound gases, consisting of three or more of these elements with oxygen, are formed and discharged. As this process must necessarily be carried on at the surface of the earth, its products are diffused through the atmosphere, dissolved by water, and absorbed by the soil. They furnish the principal nutritious matter for the support of vegetables, and are again prepared for the nourishment of animals.

**PUTTINGSTONE**, *n. s.* Putting and stone. That is, a stone thrown or placed by the hands.

In some parts of Scotland, stones are laid at the gates of great houses, which they call *putting stones*, for trials of strength. *Pope.*

**PUTTOCK**, *n. s.* Lat. *buteo*. A buzzard.

Who finds the partridge in the *puttock's* nest,  
But may imagine how the bird was dead?

*Shakspeare.*

The next are those which are called birds of prey, as the eagle, hawk, *puttock*, and cormorant.

*Peacham.*

**PUTTY**, *n. s.* Fr. *potée*; Sp. *potea*. A kind of powder on which glass is ground; a cement of glass.

An object glass of a fourteen foot telescope, made by an artificer at London, I once mended considerably, by grinding it on pitch with *putty*, and leaning on it very easily in the grinding, lest the *putty* should scratch it. *Newton.*

**PUTTY** is compounded of whiting and lintseed oil, beaten together to the consistence of a thick dough. It is used by glaziers for fastening in the squares of glass in sash windows, and by painters for stopping up the crevices and clefts in timber, &c.

**PUTUMAYO**, or Ica, a river of South America, which has its rise in the district of Ibarra, Quito, about eighty miles to the south of Popayan. Its course is S. S. E. about 300 miles, when, being joined by a branch of the Caquet, it takes the name of Ica, and, after a south-east course of about 200 miles, joins the Amazons, in long. 50° 40' W., lat. 3° 30' S. It washes down considerable quantities of gold. There is a settlement of this name on the river.

**PUY** (Peter de), a learned French writer, born in Paris in 1583. He wrote twelve treatises, chiefly on political subjects; such as, 1. The Origin of the Salique Law: 2. The Liberties of the Gallican Church: 3. The History of the

Templars, &c. He died in 1652, aged seventy-two.

**PUY**, *REVESSIO*, a city and post town of high antiquity, and the principal place of the department of the Upper Loire, France, containing 13,000 inhabitants, and having an inferior court under the royal court of Riom; a board of manufactures, an agricultural society, and a communal college. It stands in a fine situation, in the centre of three broad and very fertile valleys, each watered by a river, and crossed by three great roads. Rising in the form of an amphitheatre on the south side of mount Anis, overtopped by the vertical rock of Corneil, and surrounded with volcanic rocks, richly cultivated fields, pretty country houses, gardens, shrubberies, fruit trees, and verdant meadows, this town presents a most picturesque appearance. It is generally well built, the houses being constructed of lava, which is very abundant in the neighbourhood; the streets, which are paved with the same material, are wide and airy, but very steep and impassable for carriages.

Near the top of the hill appears the cathedral, the front of which is a mixture of ancient and Gothic architecture, presenting four rows of columns and porticoes with large arches, the middle one, which is most magnificent, being the entrance to the church. The ascent is by an immense flight of 118 steps, covered with a lofty vaulted roof, above which rises full half of the building. The steeple is of a pyramidal form, and very lofty; built entirely of volcanic stone. In the lower part of the town is a very steep basaltic rock, which resembles a tower, and on the summit of it stands the church of St. Michael. This rock, which is 300 feet high, has the form of a cone; and the steeple of the church, pointed and extremely slender, rises like an obelisk over all. The ascent to this building is by 260 steps cut in the rock.

Here are considerable manufactories of lace, thread, black lace and blond, common stuffs, woollen counterpanes, and skin bottles for wine, nail factories, a foundry, tan-yards, fulling-mills, and dye-houses. The trade consists in corn, lace, cloth, serge, iron goods, delf-ware, mules, horses, and cattle. The public library containing 5000 volumes, the museum of pictures, statues, and antiquities, are also worth notice; as well as the tomb of Duguesclin, the promenade of Breuil, and the assembly room: an ancient building, in good preservation, once consecrated to Diana. About a mile and a half from Puy is the village of Espailly, remarkable for the ruins of its ancient castle, and some curious groups of basaltic prisms, called the organs of Espailly. This city is fifty-eight miles south of Montbrison, ninety south-west of Lyons, sixty-three north-west of Privas, eighty-seven south-east of Clermont, and 375 south of Paris.

**PUY-DE-DOME**, a department of France, is formed out of the former province of Lower Auvergne, and derives its name from a high mountain which overtops the whole chain of the Domes Mountains that extend over this country. The principal place of this prefecture is Clermont-Ferrand, and it consists of five arrondissements, Clermont-Ferrand, Ambert, Issoire,

Riom, and Thiers, having a total population of 553,410 souls, on an area of 3295 square miles, and yielding a revenue of 22,428,000 francs. These are subdivided into fifty cantons and 438 communes. This forms part of the nineteenth military division, having a royal court at Riom, and a bishopric at Clermont, and consists of four electoral arrondissements, which send seven members to the chamber of deputies. The department is bounded by that of the Allier on the north, on the east by that of the Loire, on the south by those of the Upper Loire and Cantal, and on the west by those of the Creuse and the Corrèze.

This country presents, through almost its whole extent, mountains of remarkable elevation, among which are found rich hollows, beautiful valleys, and plains of the greatest fertility. The mountains are nearly all volcanic, and the whole chain extends, from south to north, over a space of fifteen or eighteen miles, in which are at least forty Puy, with their ancient craters, ravines, torrents of lava, prisms, and columns of basalt. Above these extends the smiling Limagne, the fertile soil of which is covered with orchards and vineyards, fruitful fields richly cultivated, and fine meadows intersected by a great number of rivulets and canals. The plains are filled with chestnut trees, the green foliage of which gives an indescribable charm to this delightful country. A number of artificial lakes, serving the purpose of watering the lands, are formed by a raised causeway resting on the sides of two neighbouring hills, which interrupts the course of the streams, and thus, swelling them insensibly, causes them to overflow and fertilize the pastures; where feed vast herds of horses and cattle of every description. In the chain or rather group of the Dômes and the Dore, which cover a great portion of the department, are every where discoverable the effects of former volcanic eruptions; and the currents of lava yield most of the petrifications dug for the building of houses: indeed whole towns are constructed of it. The volcanic cinders are very favorable to vegetation. The soil is most cultivated with horses and mules, and yields more than a supply for its population. It contains 54,250 hectares of forest (chiefly oak and fir), and 22,000 hectares of vineyards, and the mean produce of every hectare of arable land is twenty-four francs twenty-eight centimes.

The productions of this department consist in corn of all sorts, chestnuts, very good hemp, fruit, good wine, wood, and excellent pasturage. The lakes and rivers abound in fish; horses of a small kind are bred, as well as horned cattle and sheep. There are also mines of lead and antimony; quarries of marble of different colors, granite, graystone, millstone, tripoli, puzzolani, basalt, and plaster, and pits of coal. There is a royal depôt of standard measures at Parentignac, a royal sheep walk from Puy-de-Dôme to St. Genest, and a large botanical garden at Clermont. At Mont-d'or-les-Bains, at Chateaumont, at Chatel Guyon, at St. Myon, at St. Nectaire, at St. Marguerite au Tambour, at St. Mark, and at Chateldon, are establishments of mineral waters and warm baths. The principal manufactures are those of linen, camlets, tent cloths, Turkish

satins blond-lace, playing cards, salt-petre, chemicals, glue, candles, mercury goods, ironmongery, cutlery, kettles, and copper vessels. They have also cotton and wool-spinning manufactories, paper-mills, delf and other potteries, brass foundries, tan yards, numerous hydraulic saw-mills, &c. The trade consists in wines, corn, brandies, liqueurs, dry confectionary, walnut and hemp-seed oil, cattle, Auvergne cheeses, hemp, wool, linen, leather, paper, wood, fir-planks, coal, &c. This department is watered by the Allier, which is navigable, the Doré, the Dordogne, the Sioule, and the Morge; it is also crossed by the great roads of Lyons, Limoges, and Moulins.

**PUY-DE-DÔME**, a celebrated mountain in Auvergne, situated towards the centre of the chain of the Dôme, which extends from north to south over a space of twenty-four miles, but varying considerably in breadth. This mountain is in the centre of the chain, and much higher than those around, appearing like a giant in the midst of his children; one of the mountains indeed, called the Little Puy-de-Dôme, rises at its side, and, being united at the base, seems to spring out of it. The Puy-de-Dôme presents a majestic cone, exact in all its proportions, having an extensive hollow like a disk at its top. From the base to the summit, notwithstanding its steepness, it is covered with a verdure, on which numerous herds of cattle feed; and the whole surface is a grass plat, except in two or three places, where the protuberances of white lava appear, and show that the mountain has been volcanic. This magnificent extent of verdure gives an inconceivable charm to a scene abounding in grandeur and beauty.

The ascent to the mountain is by two different roads, one on the south side, called the road of Alagnat, the other on the north, called the Gravoise. From the crest one of the finest and richest prospects in the world is unfolded to the view. Elevated nearly 6000 feet above the level of the sea, and nearly 4000 above that of Clermont, there is no limit to the sight for an immense distance; below you are seen the forty neighbouring Puy, with their ancient craters, their ravines, currents of lava, and beds of black and red puzzolain. Farther distant is the whole country of Limagne, with its towns, villages, and hills without number; on all sides are fields of every color, vineyards, houses, roads, and mountains stretching into the distance, till they are lost to the view, and including an extent of nearly 400 miles.

Although the Puy is only a scorched rock, yet the rain and vapors that it incessantly imbibes give it an amazing fertility, which it communicates to all the neighbouring mountains; all of them, with only one or two exceptions, being covered with grass. This mountain has been rendered immortal by the experiments of Pascal here on the weight of the atmosphere.

**PUZZLE**, *v. a.*, *v. n.*, & *n. s.* For postle (or apposal as it has been written) from pose. Skinner. To perplex; entangle; confound; embarrass; involve; put to a stand; tease; be bewildered, perplexed, or awkward: a puzzle is a perplexity; a perplexing occurrence; embar-

rassment; also a child's toy designed to exercise ingenuity.

I say there is no darkness but ignorance, in which thou art more *puzzled* than the Egyptians in their fog.

*Shakspeare.*

Men in great fortunes are strangers to themselves, and, while they are in the *puzzle* of business, they have no time to tend their health either of body or mind.

*Bacon's Essays.*

I shall purposely omit the mention of arguments which relate to infinity, as being not so easily intelligible, and therefore more apt to *puzzle* and amuse, than to convince.

*Wilkins.*

Both armies of the enemy would have been *puzzled* what to have done.

*Clarendon.*

A very shrewd disputant in those points is dexterous in *puzzling* others, if they be not thorough-paced speculators in those great theories.

*More.*

The servant is a *puzzling* fool that heeds nothing.

*L'Estrange.*

These, as my guide informed me, were men of subtle tempers, and *puzzled* politicks, who would supply the place of real wisdom with cunning and avarice.

*Tatler.*

He is perpetually *puzzled* and perplexed amidst his own blunders, and mistakes the sense of those he would confute.

*Addison.*

I did not indeed at first imagine there was in it such a jargon of ideas, such an inconsistency of notions, such a confusion of particles, that rather *puzzle* than connect the sense.

*Id.*

Persons who labour under real evils will not *puzzle* themselves with conjectural ones.

*Clarissa.*

She strikes each point with native force of mind, while *puzzled* learning blunders far behind.

*Young.*

Few angles were there in her form, 'tis true, Thinner she might have been and yet scarce lose, Yet, after all, 'twould *puzzle* to say where It would not spoil some separate charm to pare.

*Byron.*

**PUZZULANA TERRA, or TERRA POZZOLANA,** is a grayish kind of earth used in Italy for building under water. The best is found about Puteoli, Baiæ, and Cumæ, in Naples, from the first of which places it derives its name. It is a volcanic product, composed of heterogeneous substances, thrown out from the burning mouths of volcanoes in the form of ashes; sometimes in such large quantities, and with so great violence, that whole provinces have been covered with it at a considerable distance. This volcanic earth is of a gray, brown, or blackish color; of a loose, granular, or dusty and rough, porous or spongy texture, resembling a clay hardened by fire, and then reduced to a gross powder. Its specific gravity is from 2.57 to 2.8; and it is in some degree magnetic: it scarcely effervesces with acids, though partially soluble in them. It easily melts per se; but its most distinguishing property is, that it hardens very suddenly when mixed with one-third of its weight of lime and water; and forms a cement which is more durable in water than any other. According to Bergman's analysis, 100 parts of it contain from 55 to 60 of siliceous earth, 20 of argillaceous, 5 or 6 of calcareous, and from 15 to 20 of iron. It is found also in France, in the late provinces of Auvergne and Limoges.

**PUZZUOLO, or Pozzuoli,** the ancient Puteoli, a celebrated town of Italy, delightfully situated on a peninsula, in the centre of the noble bay of this name. In ancient times this was

the chief mart of the inhabitants of Cumæ, and a rendezvous for merchants from Italy, Sicily, and Greece: the baths allured the most opulent Romans to its vicinity. But the devastations of war and earthquakes have long since greatly reduced it. Its population of about 1000 is now confined to the point which formed the ancient port. But in a square of the town stands a beautiful marble pedestal, covered with bas-reliefs, representing in allegorical figures the fourteen towns of Asia Minor that were destroyed by an earthquake, and rebuilt by Tiberius. The cathedral, which occupies the site of an ancient temple and is built chiefly of its materials, has a subterranean edifice attached, called the labyrinth, divided into a number of apartments. On the hill behind the town are the remains of an amphitheatre of considerable extent; but only the gates and portions of the vaults remain. Here are, however, massy remains of the temple of Jupiter Serapis, and of the mole that formed the ancient port. Several of its piers and arches still stand unshaken. At the end of this mole began the bridge of Caligula, which extended across part of the bay to Baiæ, no less than half a mile. Puzzuolo is still a bishop's see. In the neighbourhood is the plain of Solfotara. It is seven miles west of Naples.

**PWLLIELY,** a large market town of North Wales, in Carnarvonshire, seated on the coast between two rivers. It is contributory to Caernarvon in sending one member to parliament; and lies six miles south of Nevin, twenty S. S. W. of Caernarvon, and 243½ north-west of London.

**PYANEPSIA,** in antiquity, an Athenian festival celebrated on the seventh day of the month Pyanepsion. Plutarch ascribes the institution of this feast to Theseus, who, after the funeral of his father, on this day paid his vows to Apollo, because the youths who returned with him safe from Crete then made their entry into the city. On this occasion these young men, putting all that was left of their provisions into one kettle, feasted together on it, and made great rejoicing. The Athenians carried about an olive branch, bound about with wool, and crowned with all sorts of first fruits, to signify that scarcity and barrenness had ceased, singing in procession a song. And, when the solemnity was over, it was usual to erect the olive branch before their doors as a preservative against scarcity and want.

**PYCNOSTYLE,** in ancient architecture, a building where the columns stand very close to each other; only one diameter and a half of the column being allowed for the intercolumniations. The pycnostyle chiefly belonged to the composite order, and was used in the most magnificent buildings.

**PYDNA,** an ancient city of Macedonia, originally called Citron, seated between the mouths of the Aliacmon and Lydius. In this city Casander murdered the mother, widow, and son of Alexander the Great. A decisive battle was afterwards fought near it A. A. C. 168, between the Romans under Paulus Æmilius and the Macedonians under Philip V., in which the latter was defeated, and his kingdom was a few years after made a Roman province.

**PYE** (Henry James), LL. D., an English

poet, Dr. Southey's predecessor in the laureateship, was born in London in 1745. After receiving a private education, he went to Magdalen College Oxford, and took the honorary degree of master of arts in 1766, and that of doctor of laws in 1772. He was for some time in the Berkshire militia, and embarrassed himself by standing a contest for the representation of the county. In 1790 he became poet laureat; and in 1792 a police magistrate. He died August 11th, 1813. His principal works are, 1. *Faringdon Hill*, a poem. 2. Six odes of Pindar, translated into English verse. 3. *The Progress of Refinement*, a poem. 4. Poems on various subjects, 2 vols. 5. *A Translation of the Poetics of Aristotle*. 6. *Lenore*, a tale from the German of Burger. 7. *The Democrat*, 2 vols. 8. *The Aristocrat*, 2 vols. 9. *Alfred*, an epic poem. 10. Another collection of poems, 2 vols. 11. *Comments on the Commentators on Shakspeare*, 8vo. 12. *A translation of the hymns and epigrams of Homer*.

**PYGMALION**, in fabulous history, a king of Cyprus, who, being disgusted at the dissolute lives of the women of his island, resolved to live in perpetual celibacy; but, having made a statue of ivory, he so much admired it that, at the high festival of Venus, he fell down before the altar of that goddess, and besought her to give him a wife like the statue he had made. At his return home he embraced his ivory statue, when he perceived that it became sensible by degrees, and was at last a living maid, who found herself in her lover's arms the moment she saw the light. Venus blessed their union; and in nine months she was delivered of a son, named Paphos.

**PYGMALION**, king of Tyre, son of Belus, and brother of queen Dido, who founded Carthage. He succeeded his father, but became odious by his avarice and cruelty; and murdered Sichaüs, the husband of Dido, in a temple of which he was priest, on which Dido fled with her husband's treasure. He died in his fifty-first and forty-seventh of his reign.—Virg. *Æn.* i. 347. Justin, 18. c. 5.

**PYGMY**, *n. s.* Fr. *pygmée*; Gr. *πυγμαίος*. A dwarf; one of a nation fabled to be only three spans high; any little thing or person.

They, less than smallest dwarfs in narrow room,  
Throng numberless like that *pygmean* race  
Beyond the Indian mount.

If they deny the present spontaneous production of larger plants, and confine the earth to as *pygmy* births in the vegetable kingdom as they do in the other; yet surely in such a supposed universal decay of nature, even mankind itself that is now nourished, though not produced, by the earth, must have degenerated in stature and strength in every generation.

Can place or lessen us or aggrandise?

*Pygmies* are *pygmies* still, tho' perched on Alps,  
And *pyramids* are *pyramids* in vales.

**PYLADES**, a son of Strophius, king of Phocis, by a sister of Agamemnon. He was educated with his cousin Orestes, with whom he formed the most inviolable friendship, and whom he assisted to revenge the murder of Agamemnon, by assassinating Clytemnestra and Ægisthus. He also accompanied him into Taurica Chersonesus; and Orestes rewarded him for his services by

giving him his sister Electra in marriage. **Pylades** had by her two sons, Medon and Strophius. The friendship of Orestes and Pylades became proverbial.

**PYLORUS**. See **ANATOMY**.

**PYLOS**, an ancient town of Messenia, on the west coast of Peloponnesus, at the foot of Mount Ægalæus, opposite the island Sphacteria, in the Ionian Sea; seated on the promontory of Coryphasion, a name also given to the town. It was built by Pylus, at the head of a colony of Leleges from Megara, who were dispossessed of it by Neleus, the father of Nestor, who called it Nelea.

**PYRAMID**, *n. s.* Fr. *pyramide*; Gr. *πυραμῖς*. From *πυρ* fire; because fire ascends in the figure of a cone. A solid geometrical figure, whose base is a polygon, and whose sides are plain triangles, their points meeting in one: the two adjectives and adverbs corresponding: *pyramis* is an obsolete form of the noun substantive.

Know, Sir, that I will not wait pinioned at your master's court; rather make my country's high *pyramids* my gibbet, and hang me up in chains.

*Shakspeare. Antony and Cleopatra.*  
The form of a *pyramid* in flame, which we usually see, is merely by accident, and that the air about, by quenching the side of the flame, crusheth it, and extenuateth it into that form, for of itself it would be round, and therefore smoke is in the figure of a *pyramis* reversed; for the air quencheth the flame, and receiveth the smoke.

An hollow crystal *pyramid* he takes,  
In firmamental waters dipt above,  
Of it a broad extinguisher he makes,  
And hoods the flames.

The *pyramidal* idea of its flame, upon occasion of the candles, is what is in question.

Of which sort likewise are the gems or stones, that are here shot into cubes, into *pyramidal* forms, or into angular columns.

Olympus is the largest, and therefore he makes it the basis upon which Ossa stands, that being the next to Olympus in magnitude, and Pelion being the least, is placed above Ossa, and thus they rise *pyramidically*.

Virtue alone outbuilds the *pyramids*;  
Her monuments shall last when Egypt's fall.

**PYRAMID**, in geometry, a solid figure, whose base is a polygon, and whose sides are plain triangles, their several points meeting in one, called the vertex of the pyramid.

Hence the superficies of a given pyramid is easily found by measuring these triangles separately; for their sum, added to the area of the base, is the surface of the pyramid required. It is no less easy to find the solid content of a given pyramid; for, the area of the base being found, let it be multiplied by the third part of the height of the pyramid, or the third part of the base by the height, and the product will give the solid content, as is demonstrated by Euclid, lib. xii. prop. 7.

**PYRAMIDS OF EGYPT**. These celebrated buildings, ranked by the most ancient historians among the wonders of the world, have for many ages excited the attention of the curious and the criticism of the learned. The pyramids of Goe-

za or Gizeh, so denominated from a village of that name on the banks of the Nile, are the largest, and are distant from that river about eleven miles. The three which most attract the notice of travellers stand near one another on the west side of the river, almost opposite to Cairo, and not far from the spot whereon stood the ancient Memphis. The great appearance of antiquity which they display favors the supposition that the whole of these wonderful works must have been constructed at an earlier period than any other edifices that are to be seen in Egypt. Homer is silent respecting them; but his silence is no proof that they were not in existence in his time. In the time of Herodotus as little was known concerning the second pyramid as before the late opening, with this exception, that in his time it was understood to be nearly in the state in which it was left when closed by the builders.

These three pyramids are named after three kings, whose tombs they are supposed to be, viz. Cheops, Cephrenes, and Mycerinus. Of these the largest, that of Cheops, was faced with white marble, as was also the second, and its four sides face the four cardinal points. The ascent to the top is by steps, the lowermost being nearly four feet high and three broad; the second of the same dimensions, but retiring inward from the first nearly three feet; and in the same manner the third row is placed upon the second, and the rest in the same order to the top, which terminates in a small flat or square; and they are so disposed that a line stretched from the bottom to the top would touch the angle of every step. From the time of Herodotus to the present day this pyramid has been measured by a great number of travellers and learned men, and their different calculations have only increased the uncertainty. The following table will show, at least, how difficult it is to come at the truth.

#### GREAT PYRAMID.

	Height.		Width of one of its sides.
	French feet.	French feet.	
Herodotus . . . . .	800 . . . . .		800
Strabo . . . . .	625 . . . . .		600
Diodorus Siculus . . . . .	600 and a fraction . . . . .		700
Pliny . . . . .	— . . . . .		708
Le Bruyn . . . . .	616 . . . . .		704
Prosper Alpinus . . . . .	625 . . . . .		750
Thevenot . . . . .	520 . . . . .		682
Niebuhr . . . . .	440 . . . . .		710
Greaves . . . . .	444 . . . . .		648
Belzoni . . . . .	456 . . . . .		684

#### NUMBER OF LAYERS OF STONE WHICH FORM IT.

Greaves . . . . .	207
Maillet . . . . .	208
Albert Liewenstein . . . . .	260
Poocke . . . . .	212
Belon . . . . .	250
Thevenot . . . . .	208

According to Herodotus, the blocks of stone which served for the construction of the pyramids were obtained from quarries of oriental mountains on the frontiers of Arabia. This, however, is contrary to the observations of modern travellers, who have ascertained that the

same chalky stone of which they are composed is the produce of the district in which they stand.

The second pyramid stands at about a bow-shot from the first, towards the south. Herodotus says, after having measured both, that it falls short of the other in magnitude; that it has no subterraneous chambers: and that the Nile is not conveyed into it by a channel, as he affirms it was into the former, but that it is of an equal altitude. Diodorus informs us that it resembles the first in its architecture, but is inferior to it in magnitude; each side of the base containing a stadium, or 600 Grecian feet in length: so that by his computation each side is less than that of the former in length by 100 feet. Pliny makes the difference to be greater by forty-six feet.

On the north and west sides of this second pyramid are two very elaborate pieces of architecture, cut out of the rock in a perpendicular direction and squared by a chisel, about thirty feet in depth and about 1400 in length; supposed to be designed for the lodgings of the Egyptian priests.

The third pyramid stands at about the distance of a furlong from the second, on an advantageous rising of the rock, so that at a distance it appears equal to the former, though in fact much lower. Herodotus says that it is 300 feet on every side, and built of Ethiopic marble. Diodorus gives the same dimensions of its base, and adds that the walls were raised fifteen stories with black stone, like Thebaic marble, and the rest finished with such materials as the other pyramids are built with; that this, though exceeded by the two former in magnitude, yet far excels them in respect to the structure, art, and magnificence of the marble; and that, on the side towards the north, the name of Mycerinus, the founder, is engraved: but this inscription has been effaced by time. Pliny writes to the same effect, except that he makes this pyramid 363 feet between the angles.

Very important discoveries in the interior of these enormous masses have been made within our own time by Messrs. Davison and Caviglio, and by M. Belzoni. The most celebrated, and perhaps the most arduous of M. Belzoni's labors, was the opening of the pyramid of Cephrenes. Herodotus was informed that this pyramid had no interior chambers, and this no doubt operated in preventing that curiosity which had long before opened the pyramid of Cheops. The account of his discovery we cannot give better than in Belzoni's own words.

On my return to Cairo, I again went to visit the celebrated pyramids of Ghiza; and, on viewing that of Cephrenes, I could not help reflecting how many travellers of different nations, who had visited this spot, contented themselves with looking at the outside of this pyramid, and went away without enquiring whether any, and what chambers, exist in it; satisfied perhaps with the report of the Egyptian priests, 'that the pyramid of Cheops only contained chambers in its interior.' I then began to consider about the possibility of opening this pyramid; the attempt was perhaps presumptuous; and the risk of un-

dertaking such an immense work without success deterred me in some degree from the enterprise. I am not certain whether love for antiquity, an ardent curiosity, or ambition, spurred me on most in spite of every obstacle, but I determined at length to commence the operation. I soon discovered the same indications which had led to the development of the six tombs of the kings in Thebes, and which induced me to begin the operation on the north side. It is true, the situations of the tombs at Thebes, their form and epochs, are so very different from those of the pyramids, that many points of observation made with regard to the former, could not apply to the latter; yet I perceived enough to urge me to the enterprise. I accordingly set out from Cairo on the 6th of February, 1818, under pretence of going in quest of some antiquities, at a village not far off, in order that I might not be disturbed in my work by the people of Cairo. I then repaired to the Kaiya Bey, and asked permission to work at the pyramid of Ghiza in search of antiquities. He made no objection, but said that he wished to know if there was any ground about the pyramid fit for tillage; I informed him that it was all stones, and at a considerable distance from any tilled ground. He nevertheless persisted in enquiring of the cashief of the province, if there was any good ground near the pyramids; and, after receiving the necessary information, granted my request.

Having thus acquired permission, I began my labors on the 10th of February, at a point on the north side in a vertical section at right angles to that side of the base. I saw many reasons against my beginning there, but certain indications told me that there was an entrance at that spot. I employed sixty laboring men, and began to cut through the mass of stones and cement which had fallen from the upper part of the pyramid, but it was so hard joined together, that the men spoiled several of their hatchets in the operation; the stones which had fallen down along with the cement having formed themselves into one solid and almost impenetrable mass. I succeeded, however, in making an opening of fifteen feet wide, and continued working downwards in uncovering the face of the pyramid; this work took up several days, without the least prospect of meeting with any thing interesting. Meantime I began to fear that some of the Europeans residing at Cairo might pay a visit to the pyramids, which they do very often, and thus discover my retreat, and interrupt my proceedings.

On the 17th of the same month we had made a considerable advance downwards, when an Arab workman called out, making a great noise, and saying that he had found the entrance. He had discovered a hole in the pyramid into which he could just thrust his arm and a djerid of six feet long. Towards the evening we discovered a larger aperture, about three feet square, which had been closed in irregularly, by a hewn stone; this stone I caused to be removed, and then came to an opening larger than the preceding, but filled up with loose stones and sand. This satisfied me that it was not the real but a forced passage, which I found to lead inwards and towards the

Vol. XVIII.

south;—the next day we succeeded in entering fifteen feet from the outside, when we reached a place where the sand and stones began to fall from above. I caused the rubbish to be taken out, but it still continued to fall in great quantities; at last, after some days labor, I discovered an upper forced entrance, communicating with the outside from above, and which had evidently been cut by some one who was in search of the true passage. Having cleared this passage, I perceived another opening below, which apparently ran towards the centre of the pyramid. In a few hours I was able to enter this passage, and found it to be a continuation of the lower forced passage, which runs horizontally towards the centre of the pyramid, nearly all choked up with stones and sand. These obstructions I caused to be taken out; and at halfway from the entrance I found a descent which also had been forced; and which ended at the distance of forty feet. I afterwards continued the work in the horizontal passage above, in hopes that it might lead to the centre; but I was disappointed, and at last was convinced that it ended there; and that, to attempt to advance in that way would only incur the risk of sacrificing some of my workmen; as it was really astonishing to see how the stones hung suspended over their heads, resting, perhaps, by a single point. Indeed one of these stones did fall, and had nearly killed one of the men. I therefore retired from the forced passage, with great regret and disappointment.

Notwithstanding the discouragements I met with, I recommenced my researches on the following day, depending upon my indications. I directed the ground to be cleared away to the eastward of the false entrance; the stones, encrusted and bound together with cement, were equally hard as the former, and we had as many large stones to remove as before. By this time my retreat had been discovered, which occasioned me many interruptions from visitors: among others was the abbé de Forbin.

On February 28th we discovered a block of granite in an inclined direction towards the centre of the pyramid, and I perceived that the inclination was the same as that of the passage of the first pyramid, or that of Cheops; consequently I began to hope that I was near the true entrance. On the 1st of March we observed three large blocks of stone one upon another, all inclined towards the centre: these large stones we had to remove as well as others much larger as we advanced, which considerably retarded our approach to the desired spot. I perceived, however, that I was near the true entrance, and in fact, the next day about noon, on the 2nd of March, was the epoch at which the grand pyramid of Cephrenes was at last opened, after being closed up for so many centuries that it remained an uncertainty whether any interior chambers did or did not exist. The passage I discovered was a square opening of four feet high and three and a half wide, formed by four blocks of granite; and continued slanting downward at the same inclination as that of the pyramid of Cheops, which is an angle of 26°. It runs to the length or 104 feet five inches, lined the whole way with

T



granite. I had much to do to remove and draw up the stones which filled the passage down to the portcullis or door of granite, which is fitted into a niche also made of granite. I found this door supported by small stones within eight inches of the floor, and in consequence of the narrowness of the place it took up the whole of that day and part of the next to raise it sufficiently to afford an entrance; this door is one foot three inches thick, and, together with the work of the niche, occupies six feet eleven inches, where the granite work ends: then commences a short passage, gradually ascending towards the centre, twenty-two feet seven inches, at the end of which is a perpendicular of fifteen feet: on the left is a small forced passage cut in the rock, and also above, on the right, is another forced passage which runs upwards and turns to the north thirty feet, just over the port-cullis. There is no doubt that this passage was made by the same persons who forced the other, in order to ascertain if there were any others which might ascend above, in conformity to that of the pyramid of Cheops. I descended the perpendicular by means of a rope, and found a large quantity of stones and earth accumulated beneath, which very nearly filled up the entrance into the passage below which inclines towards the north. I next proceeded towards the channel that leads to the centre, and soon reached the horizontal passage. This passage is five feet eleven inches high, three feet six inches wide, and the whole length, from the above-mentioned perpendicular to the great chamber, is 158 feet, 8 inches. These passages are partly cut out of the living rock, and at half-way there is some mason's work, probably to fill up some vacancy in the rock; the walls of this passage are in several parts covered with incrustations of salts.

'On entering the great chamber, I found it to be forty-six feet three inches long, sixteen feet three inches wide, and twenty-three feet six inches high; for the most part cut out of the rock, except that part of the roof towards the western end. In the midst we observed a sarcophagus of granite, partly buried in the ground, to the level of the floor, eight feet long, three feet six inches wide, and two feet three inches deep inside, surrounded by large blocks of granite, being placed apparently to guard it from being taken away, which could not be effected without great labor; the lid of it had been opened; I found in it only a few bones of a human skeleton, which merit preservation as curious reliques, they being in all probability those of Cephrenes, the reported builder of this pyramid. On the wall of the western side of the chamber is an Arabic inscription, a translation of which has been sent to the British Museum. It testifies that, 'this pyramid was opened by the Masters Mahomet El Aghar and Osman, and that it was inspected in presence of the Sultan Ali Mahomet the 1st, Ugloch.' There are also several other inscriptions on the walls, supposed to be Coptic; part of the floor of this chamber had been removed in different places, evidently in search of treasure, by some of those who had found their way into it. Under one of these stones I found a piece of metal something like the thick part of

an axe, but it is so rusty and decayed that it is almost impossible to form a just idea of its form. High up and near the centre there are two small square holes, one on the north and the other on the south, each one foot square; they enter into the wall like those in the great chamber of the first pyramid. I returned to the before-mentioned perpendicular, and found a passage to the north in the same inclination of  $26^\circ$  as that above: this descends forty-eight feet six inches, where the horizontal passage commences, which keeps the same direction north fifty-five feet, and half-way along it there is on the east a recess of eleven feet deep. On the west side there is a passage, twenty feet long, which descends into a chamber thirty-two feet long and nine feet nine inches wide, eight and six feet high; this chamber contains a quantity of small square blocks of stone, and some unknown inscriptions written on the walls. Returning to the original passage, and advancing north, near the end of it is a niche to receive a port-cullis like that above. Fragments of granite, of which it was made, are lying near the spot; advancing still to the north I entered a passage which runs in the same inclination as that before-mentioned, and at forty-seven feet six inches from the niche it is filled up with some large blocks of stone, put there to close the entrance which issues out precisely at the base of the pyramid. According to the measurements, it is to be observed that all the works below the base are cut into the living rock, as well as part of the passages and chambers before-mentioned. Before I conclude I have to mention that I caused a range of steps to be built, from the upper part of the perpendicular to the passage below, for the accommodation of visitors.

'It may be mentioned that, at the time I excavated on the north side of the pyramid, I caused the ground to be removed to the eastward between the pyramid and the remaining portico which lies nearly on a line with the pyramid and the sphinx. I opened the ground in several places, and in particular at the base of the pyramid; and in a few days I came to the foundation and walls of an extensive temple, which stood before the pyramid at the distance of only forty feet. The whole of this space is covered with a fine platform, which no doubt runs all round the pyramid. The pavement of this temple, where I uncovered it, consists of fine blocks of calcareous stone, some of which are beautifully cut and in fine preservation; the blocks of stone that form the foundation are of an immense size. I measured one of twenty-one feet long, ten feet high, and eight in breadth (120 tons weight each); there are some others above ground in the porticoes which measured twenty-four feet in length, but not so broad nor so thick.'

The great pyramid of Gizeh was explored with extraordinary labor and peril by Mr. Davison, British Consul at Algiers, who accompanied Wortley Montague to Egypt, in the year 1763; and, in order to apprehend the importance of the recent discoveries, it is necessary to understand the extent to which that gentleman had carried his researches.

One of his principal objects was to ascertain the depth of what had hitherto been denominated the Well. After descending, by means of a rope tied about his body, to the bottom of the first shaft, he found, on the south side, at the distance of eight feet from the lower extremity of that shaft, a second opening which reached in a perpendicular direction to the depth of only five feet; and, at the distance of four feet and a half from the bottom of this shaft, he found a third opening, which was so much closed up by a large stone at the mouth as barely to admit the body of a man. Having with the utmost difficulty prevailed upon the Arabs who accompanied him to come down and hold the rope by which he was suspended, he proceeded in his descent, and about half way down he came to a grotto nearly fifteen feet long, four or five feet wide, and as high as a man of ordinary stature. From this place the shaft took a sloping direction for a little way, and then becoming more perpendicular, he at length reached the bottom which was completely closed with sand and rubbish. Here he found a rope ladder, which had been used by Mr. Wood (author of the Ruins of Palmyra and Balbec), who had proceeded no farther than the grotto; and, though it had been left there sixteen years before, was as fresh and strong as if perfectly new. The depth of the first of these shafts was twenty-two feet, of the second twenty-nine, and of the third ninety-nine, making, with the addition of the five feet between the first and second shafts, a total descent of 155 feet.

Upon a subsequent visit, Mr. Davison next proposed to explore an opening which he had discovered at the top of the gallery: and for this purpose provided himself with several short ladders, capable of being fastened to one another by wooden pins, so as to extend, when thus united, to the length of twenty-six feet. Having mounted by the assistance of this ladder to the opening which he had observed, he found a passage two feet four inches square, which turned immediately to the right; but, on account of the dust and bats-dung with which it was covered to the depth often of a foot, it was with the greatest difficulty, and the constant hazard of suffocation, that he crawled along with his face to the ground. Upon reaching the end of this passage, he found on the right a straight entrance into a long, broad, and low room; and, both by the length and direction of the passage through which he had entered, he knew it to be situated immediately above the large room, usually called the king's chamber. This chamber is four feet longer than the one below, but exactly of the same breadth, and its covering is composed of eight stones of beautiful granite. This place could not be found by Niebuhr, though informed of its situation by Mr. Meynard who had accompanied Mr. Davison, and has never been visited since the time of the last-mentioned traveller, till the date of these recent discoveries which we now proceed to describe.

Captain or Mr. Caviglia, the master of a mercantile vessel in the Mediterranean trade, set out from Cairo on the 8th of January 1817, with a resolution to employ his utmost exertions in exploring the numerous passages and interior re-

cesses of the pyramids of Ghizeh. Conceiving that the descent of the Well in the great pyramid had never been thoroughly prosecuted, he entered the shaft, as Mr. Davison had done, with a lamp in his hand and a rope about his middle. He describes the different shafts nearly in the same manner as that gentleman does, but discovered the additional fact, that the interior was lined with masonry above and below the grotto, for the purpose, as was supposed, of supporting one of those insulated beds of gravel, which are frequently found in rock. He found nothing at the bottom but loose stones and rubbish; and was compelled, by the excessive heat and foul air, to reascend the shaft with all possible expedition; but, before he reached the grotto, all his lights were extinguished in rapid succession. Neither this experience of the enervating heat and impure air of these subterranean channels (which have often been known to cause the stoutest man to faint, even in getting up as far as the gallery), or the various histories current in Cairo of persons who were supposed to have perished in these attempts, could deter this enterprising traveller from renewing his researches, with a degree of perseverance as unexampled as his success was unexpected. Having remarked that the ground at the bottom of the Well gave a hollow sound under his feet, he was convinced that there must be some concealed outlet below; and, having pitched his tent in front of the pyramid, he hired a number of Arabs to draw up the rubbish from the spot with baskets and cords. With the aid of an order from the Kiaya-Bey, and the payment of enormous wages, 'it is still,' says Mr. Salt, 'almost inconceivable how he could so far surmount the prejudices of these people as to induce them to work in so confined a space, where a light after the first half hour would not burn, and where, consequently, every thing was to be done by feeling and not by sight; the heat at the same time being so intense, and the air so suffocating, that, in spite of all precautions, it was not possible to stay below an hour at a time, without suffering from its pernicious effects. At length, indeed, it became so intolerable that one Arab was brought up nearly dead, and several others on their ascending fainted away; so that, at last, in spite of the command laid upon them, they almost entirely abandoned their labor, declaring that they were willing to work but not to die for him.'

Disappointed in this pursuit, Mr. Caviglia applied his endeavours to clear the principal entrance of the pyramid, which had from time immemorial been so much obstructed as to render it necessary for those who entered the passage to creep on their hands and knees: by this means he hoped to admit a freer passage for the air into the interior. In the course of these labors he made the unexpected discovery that the main passage leading from the entrance continued downwards, with the same degree of inclination, the same dimensions, and the same finish of work at the sides, as at the beginning of the channel. Having cleared out this inclined passage to the length of 150 feet, the air became so impure, and the heat so suffocating, that he experienced the same difficulties in pro-

vailing with the Arabs to continue the work, and was himself attacked with spitting of blood, and other symptoms of impaired health. Still, however, persevering in his researches till he had excavated the passage to a distance of 200 feet, his labors were rewarded with the discovery of a door-way on the right side, from which a smell of sulphur was soon perceived to issue. Recollecting, that in his first visit to the pyramid, he had burned some sulphur at the bottom of the well, for the purpose of purifying the air, he conceived the probability of there being a communication by this door-way with the well. This conjecture was soon realised by the discovery that the channel opened directly upon the well, where he found the baskets, cords, and other implements, which had been left by the workmen. The opening of this communication afforded a complete circulation of air along the new passage, and up the shaft, so as greatly to facilitate his future operations. This new passage, however, did not terminate at this door-way; but, continued twenty-three feet farther, in the same line of inclination, till at length it took a horizontal direction for the space of above twenty-eight feet, and then opened into a spacious chamber immediately under the centre of the pyramid, and 100 feet below the base. This chamber, with the greatest part of the passage leading to it, is all cut out of the solid rock upon which the pyramid is built, and which projects into the body of the pyramid about eighty feet above the level of its external base. The chamber itself is sixty feet long, twenty-seven broad, with a high but flat roof; and, when first discovered, was nearly filled with loose stones and rubbish. The platform of the floor is irregular, nearly one-half of its length from the entrance being quite level, and about fifteen feet from the ceiling; while, in the middle space, it descends five feet lower, where there is an opening or hollow, resembling the commencement of another shaft or well; and thence, to the western end, it rises so much that there is scarcely room, at the extremity, to stand upright between the floor and the ceiling. Some Roman characters, rudely formed, and marked by the flame of a candle, were observed on the walls; but the mouldering of the rock had rendered them illegible. There was no vestige of any sarcophagus; and it is supposed that this receptacle of the dead had been spoiled of its contents by the early Arabs, under Al Mamoun, the son of Haroun al Raschid. On the south side of this chamber is an excavated passage, just sufficient to admit a person creeping along on his hands and knees, and continuing horizontally for the space of fifty-five feet, when it seems to terminate abruptly. Another passage, at the east end of the chamber, commencing with a kind of arch, runs about forty feet into the solid body of the pyramid.

Dr. Clarke says of the above well, 'We threw down some stones, and observed that they rested at about the depth which Greaves has mentioned (twenty feet); but being at length provided with a stone nearly as large as the mouth of the well, and about fifty pounds in weight, we let this fall, listening attentively to the result from the spot where the other stones rested. We were agree-

ably surprised by hearing, after a length of time which must have equalled some seconds, a loud and distinct report, seeming to come from a spacious subterraneous apartment, accompanied by a splashing noise as if the stone had been broken into pieces, and had fallen into a reservoir of water at an amazing depth.' 'Thus,' continues the doctor, 'does experience always tend to confirm the accounts left us by the ancients! for this exactly answers to the description given by Pliny of this well.' Now it is quite obvious, from Messrs. Davison and Caviglia's better 'experience,' that Dr. Clarke's 'large stone' could not, by any possibility, travel an inch beyond the bottom of the first shaft, or about twenty feet; unless we are to suppose that, on reaching the first bottom, it took a horizontal roll due south eight feet, dropped down the second shaft of five feet; then took a second roll of about five feet, and finally tumbled down the third shaft: but even thus there would be no 'splashing,' though 'the inundation of the Nile was nearly at its height;' as the new chamber discovered by Caviglia, which is even lower than the bottom of the well, is thirty feet above the level of the Nile at its greatest elevation.

Mr. Caviglia next proceeded to examine the chamber discovered by Mr. Davison, immediately above the king's chamber, and found the dust and bats' dung with which the floor was covered, increased to the depth of eighteen inches. He describes the sides and the roof of this upper apartment as coated with red granite of the finest polish, but its floor is very uneven, in consequence of its being formed by the individual blocks of granite which compose the roof of the chamber below. It is only four feet high; and it is not easy to conjecture for what purpose it could have been intended. Nothing was discovered by Mr. Caviglia that could lead to a solution of the long contested question respecting the original design of these recesses; but it is still considered as the most probable opinion that they were principally intended to secure the remains of the founder, or of the priests; and it is also conjectured that, among the contents of the sarcophagus, discovered in the pyramid of Cephrenes, some human bones may have been mixed with those of the cow.

Few subjects have occasioned more speculation than the intent and use of the Egyptian pyramids. About forty years since, a German professor published a volume to prove that these majestic remains of the most remote antiquity are nothing more than basaltic eruptions, magnificent sports of nature, and so many incontrovertible proofs of the general derangement which has taken place on the globe! It is, indeed, a remarkable example of human vanity that these buildings, reckoned among the wonders of the world, should not have preserved more certain data of their origin. Pliny mentions a number of authors who in his time had written concerning them; and all, he informs us, disagree in their accounts of those who built them. Some modern writers maintain that they were erected by the Israelites, under the tyranny of the Pharaohs, and allege to this purpose the testimony of Josephus, Antiq. lib. i. cap. 5.

According to Herodotus, and to Diodorus, the first pyramid was erected by Cheops, or Chemmis, a king of Egypt, who is said to have employed 360,000 men for twenty years in the structure. Cephrenes, brother and successor to the former king, is said to be the founder of the second pyramid; and the third is said to have been built by Mycerinus, the son of Chemmis, according to Diodorus; or, according to Herodotus, of Cheops. However, Herodotus says, that some ascribed the last to Rhodope, a courtesan, and the other two to the shepherd Philitton. The learned Greaves places the three kings who erected these pyramids in the twentieth dynasty; Cheops having begun his reign in the year 3448 of the Julian period, 490 years before the first Olympiad, and 1266 years before the Christian era. He reigned fifty years, says Herodotus, and built this pyramid, as Diodorus observes, in the 180th Olympiad; whereas he might have said 1207. Cephrenes, the builder of the second, reigned fifty-six years; and Mycerinus, the builder of the third, seven years. Bryant ascribes the structure of the pyramids to the Cuthites, or Arabian shepherds, who built Heliopolis, and who were the giants and Titans of the first ages.

The general opinion with regard to their intention and use is, that they were sepulchres and monuments of the Egyptian monarchs. This is expressly affirmed by Diodorus and Strabo, and the opinion is confirmed by the Arabian writers. The reason, says Greaves, of their erecting these magnificent structures is founded in the theology of the Egyptians, who, as Servius shows in his comment upon Virgil (*Æneid*, lib. iii.), believed that as long as the body endured so long the soul continued with it; and this was also the opinion of the Stoics. Upon this principle, that the bodies might neither be reduced to dust by putrefaction, nor converted into ashes by fire, they embalmed them, and laid them up in these stately repositories, where they might continue free from injury. Many, however, have objected to this account of the pyramids, and are of opinion that they were originally intended for some nobler purpose. If Cheops, says Dr. Shaw, or any other person who was the founder of the great pyramid, intended it only for his sepulchre, what occasion was there for such a narrow crooked entrance into it; for the well, as it is called, at the end of the entrance; for the lower chamber; for the long narrow cavities in the walls of the upper room; or, for the two anti-chambers and the lofty gallery, with benches on each side that introduce us into it. As the whole of the Egyptian theology was clothed in mysterious emblems and figures, it seems reasonable to suppose, he adds, that all these turnings, apartments, and secrets in architecture were designed for some purpose of religion, and that the deity, which was typified in the outward form of this pile, was to be worshipped within.

Major Fitzclarence, in his journey over land from India, reached Cairo shortly after the opening of the pyramid of Cephrenes had been accomplished by Belzoni; and, with the zeal and enterprize of his profession, he determined to enter into the pyramid and examine for himself,

the wonders of the central chamber, so recently laid open. With less reverence, perhaps, for the august repository of the mighty dead than might have been felt by a contemporary of the Pharaohs, he brought away a few fragments from the domus exilis Plutonia, and among the rest some small pieces of bone, one of which proved to be the lower extremity of the thigh bone, where it comes in contact with the knee joint. This singular curiosity was presented by major Fitzclarence to his royal highness the prince Regent, who submitted it to the inspection of Sir Everard Home. Sir Everard, entertaining no doubt of its being part of a human skeleton, took it to the Museum of the College of Surgeons, that, by adjusting it to the same part of different sized skeletons, he might be enabled to form some estimate of the comparative stature of the ancient Egyptians and modern Europeans. On a closer and more laborious examination, however, the fragment was found to agree with none of them; and it finally appeared that, instead of forming any part of the thigh bone of a human subject, it actually made part of that of a cow.

The large sarcophagi, instead of being the depositories of the remains of the kings of Egypt, would hence appear to have been hollowed out and sculptured with such extraordinary skill and pains to receive the mortal exuviae of the tutelary deities; and those immense masses in which they were entombed to have owed their boundless cost and magnificence to a reverential regard for 'the brutish forms' of Apis or Osiris. Probably also the kings of Egypt would order their bones to be placed with those of their gods, and thus give rise to the tradition delivered to us by Herodotus.

Some have supposed that these stupendous monuments were erected by the Egyptians as temples or altars to their god Osiris or the sun. It was natural, say they, to build them in that shape which the rays of the sun display when discovered to the eye, and which they observed to be the same in terrestrial flame, because the circumstance was combined in their imaginations with the attribute which they adored. If they were temples dedicated to the sun, it seems a natural consequence that they should likewise be places of sepulture for kings and illustrious men, as the space which they covered would be considered consecrated ground. This hypothesis is common, and is not contradicted by the present reasoning. But considering them as altars, and, as most travellers agree that they terminate in a square horizontal surface, they venture to assert that, in great and solemn acts of adoration, the Egyptians constructed fires, the flames of which, terminating in the vertex of the pyramid, completed that emanation of their deity which they admired and adored. The learned Bryant, having settled them to be temples consecrated to the deity, had no difficulty in transforming the sarcophagus into a water-trough to hold the sacred element drawn up from the Nile—a conception about as felicitous as that which would have converted the supposed sarcophagus of Alexander into a bathing-tub; a proof of which was in the holes in the bottom to let out the water!

Dr. Clarke rejects entirely all that the Greeks

have told us respecting the names of their founders, and the circumstances under which they were erected; and has recourse, as he tells us, to Arabic or Jewish tradition, to prove that some of these vast piles were raised by the Israelites during their abode in Egypt, and that the particular pyramid which is now open was the tomb of the patriarch Joseph. Its being now open is, of course, accounted for by the fact that his bones were removed by his countrymen on their departure for Canaan! 'On the whole,' say the Quarterly Reviewers, 'we can find no reason for depriving Cheops, Cephrenes, and Mycerinus of the wicked renown of having raised the useless and oppressive piles which bear their name; and though it is impossible to say when the first pyramids were erected, and whether some of them may be or may not be the work of the Israelites, it is utterly unlikely that any of them were raised by this people on their own account, or in honor of the patriarch Joseph.'

Before we take leave of these vast piles, we must advert to a circumstance which is too remarkable to be passed over. In all the pyramids that have been opened, which at Gizeh and Saccara amount at least to six, the entrance has been found at or near the centre on the northern face, and the passage thence to proceed invariably in a slanting direction downwards; the angle of the inclination being always the same. Greaves, in his *Pyramidographia*, makes that of Cheops  $26^\circ$ , and Caviglia  $27^\circ$ , which, he says, is common to all the sloping passages within the pyramid of Cheops. He found the same angle on opening one of the small pyramids to the south of that of Mycerinus, at the end of the passage of which were two chambers, leading one out of the other, both empty. Belzoni estimates the sloping passages of the pyramid of Cephrenes at  $26^\circ$ . This coincidence cannot be referred to accident, and the able Reviewer, just quoted, suggests that these passages might have been used to correct their measurement of time. The adits, as we have observed, are invariably inclined downwards, in an angle of about  $27^\circ$ , more or less, with the horizon, which gives a line of direction not far removed from that point in the heavens where the north polar star now crosses the meridian below the pole. The observation of the passage of this or some other star across this part of the meridian would give them an accurate measure of sidereal time: a point of the first importance in an age when no other instruments than rude solar gnomons, or something still more imperfect, were in use. Indeed, we know not of any method that could more effectually be adopted for observing the transit of a star with the naked eye than that of watching its passage across the mouth of this lengthened tube; and some one or more of these luminaries, when on the meridian below the pole, must have been seen in the direction of the angular adits. Dr. Young, however, observes that the observation of the pole-star was at least extremely ill contrived for the determination of time, on account of the very slow apparent motion of that star.

The pyramids of Saccara, though second only in importance to those of Gizeh, so nearly resem-

ble them in every particular as to need no separate description.

At Dashouy is a large pyramid of brick, called by Herodotus the pyramid of Asychis, and on which he reports was the following remarkable inscription:—'Do not compare me with the pyramids of stone; for I excel them as much as Jupiter excels the other gods: for those who built me thrust poles into a lake, and, collecting the mud which adhered to them, they made bricks of it, and thus they constructed me.' See EGYPT, SPRINK, and THEBES.

PYRAMUS, in ancient geography, a river of Cilicia, which rises on the north side of Mount Taurus, and runs into that part of the Mediterranean anciently called the Pamphylian Sea, between Issus and Magarassus.

PYRAMUS, in fabulous history, an unfortunate youth of Babylon, who fell in love with Thisbe, whom, as their parents disapproved of their union, he appointed to meet with in a wood; but, finding her veil all bloody, concluded she had been torn to pieces by a wild beast, on which he killed himself; and Thisbe soon after coming to the spot, and finding him dying, fell upon his sword also. Ovid celebrates their unfortunate love.

PYRE, *n. s.* Lat. *pyra*; Gr. *rop.* A pile to be burnt.

When his brave son upon the fun'ral *pyre*  
He saw extended, and his beard on fire. *Dryden.*  
Divination was invented by the Persians, and is seldom or never taken in a good sense; there are four kinds of divination, hydromancy, *pyromancy*, aeromancy, geomancy. *Ayliffe.*

*Pyrites* contain sulphur, sometimes arsenic, always iron, and sometimes copper. *Woodward.*

With tender billet-doux he lights the *pyre*,  
And breathes three am'rous sighs to raise the fire. *Pope.*

Let earth dissolve, yon ponderous orbs descend,  
And grind us into dust. The soul is safe;  
The man emerges: mounts above the wreck,  
As tow'ring flame from nature's funeral *pyre*. *Young.*

PYREIA, or PYRATERIA, in antiquity, temples consecrated to the sun, wherein a perpetual fire was kept. They were large enclosures built upon high eminences, without any covering. The Guebres, or worshippers of fire in Persia and the East Indies, have still these pyreia.

PYRENÆUS, in fabulous history, a king of Thrace, who during a storm gave shelter to the nine Muses in his palace; but afterwards attempted to offer them violence, upon which the goddesses took to their wings and flew away; and Pyreneus, attempting to fly after them from the top of a tower, fell and was killed.

PYRENE, an ancient town of Gallia Celtica, near the source of the Istor: also a fountain near Corinth.

PYRENEES, DEPARTMENT OF THE LOWER, is formed out of the former provinces of Navarre and the Bearn, France, and derives its name from its being situated at the western extremity of the Pyrenees. The principal place of this prefecture is Pau; it is divided into five arrondissements or subprefectures, containing a total population of 399,454 souls, on an area of 3492

square miles, and yielding a territorial revenue of 15,392,000 francs. These are subdivided into forty cantons and 655 communes, and form three electoral arrondissements, which send three members to the chamber of deputies. It is in the eleventh military division, having a royal court at Pau and a bishopric at Bayonne. This department is bounded on the north by the Landes and the Gers; on the east by that of the Upper Pyrenees; on the south by the Pyrenean Mountains, which separate it from Spain, and on the west by the ocean.

The surface of this country, generally mountainous and unequal, presents a great variety of productions, and agreeable and diversified scenery. It abounds with rising grounds, covered with vines yielding excellent wine, beautiful valleys affording good pasturage, and uncultivated and wild plains. On the southern side runs a range of high mountains covered with wood, terminating westward in the Pyrenees; these diminish gradually in elevation till they are lost in the sea. The soil is naturally dry and barren, and yields its produce only by dint of labor. The small plains and valleys produce rye, wheat, barley, oats, millet, and maize, on which the people chiefly subsist; hay, and very soft and fine flax, which serves for the manufacture of the Bearn linens. Great quantities of chestnuts are gathered here. Game of all kinds abounds, and the forests furnish wood for masts, timber, and building. The climate is very temperate in the plains, but cold in the mountains; yet every where very healthy. Horses and mules are used in agriculture, but the produce is insufficient for its inhabitants. There are 112,225 hectares of forests (chestnuts, oaks, pines, and firs), and 16,700 of vineyards, yielding on an average sixteen francs seven centimes per hectare of arable land. The productions are corn of all sorts, chestnuts, excellent fruit and wines, fine linen, gall nuts, salt and fresh water fish, particularly salmon, tunnies, turbot, lampreys, pilchards, and excellent trout, horses for cavalry, mules, sheep, and small horned cattle, and pigs. There are mines of silver, iron, and copper, and quarries of marble of every color, granite, slate, marl, sulphur, and cobalt; mineral waters at Laurens, at Aas, and at Cambo, and a royal stud at Pau. The manufactures chiefly consist in Bearn linens, cotton, handkerchiefs, table linen, woollen counterpanes, twine, coarse serge, stuffs for hoods, Tunisian caps, carpets, quilts, chocolate, Andaye brandy, and cream of tartar; besides cotton spinning factories, tan-yards, manufactories of white and chamois leather, dye-houses, paper-mills, and dock yards for ship building. A considerable trade is carried on in these articles, as well as drugs, liquorice juice, resinous matters, timber, salt, fine wool, Bayonne hams, &c.

The chief rivers are the Adour, the Bidassoa, the Bidouze, the Nivelle, the Nive, and the gave d'Aleron, navigable; the Rixe, the Laran, the Loy de Bearn, the Loy de France, the Gabas, the Gaves de Pau, d'Aspe, d'Ossau, and de Mauléon. It is crossed by the great roads of Mont de Marsan, Auch, Tarbes, and Bayonne.

PYRENEES, DEPARTMENT OF THE UPPER, is formed out of the Bigarre, a dependency of the

former province of Gascony, and takes its name from its natural situation in the Pyrenean Mountains. The principal town is Tarbes. It is divided into three arrondissements or subprefectures; containing a total population of 211,979 souls, on an area of 2115 square miles, and yielding a revenue of 7,769,000 francs. It is subdivided into twenty-six cantons and 501 communes; it is in the tenth military division; forms part of the diocese of Bayonne, having its royal court at Pau, and consists of three electoral arrondissements, which send five members to the chamber of deputies. This department is bounded on the north by that of the Gers, on the east by that of the Upper Garonne, on the south by the Pyrenean Mountains, which divide it from Spain, and on the west by the department of the Lower Pyrenees.

This country is covered with lofty mountains, the tops of which are covered with perpetual snows; some presenting bare peaks, towering into the clouds and receiving at their feet the waters of numerous torrents. The mountains next in size to these have their tops covered with ancient forests, which furnish excellent wood for building and other purposes: here are found a number of rare and useful plants, and excellent pasturage, feeding numerous flocks of goats and sheep. Among the mountains are scattered fertile plains, rich pastures, and vine covered hills, producing good red and white wine. The region of hills which succeeds to the large valleys is particularly well cultivated; the plains produce a little wheat, some hay, rye, barley, and especially millet. The climate is temperate in the plains, and very cold in the mountains. The inhabitants of the Upper Pyrenees are in general simple, brave, and generous; the soil is partly cultivated with mules, and yields an insufficient supply for its inhabitants. There are 67,530 hectares of forests (chestnuts, oaks, beech, and fir), and 11,000 hectares of vineyards; the produce of each hectare of arable land being thirteen francs eighty-five centimes.

Beside the above-mentioned productions, buckwheat and maize are grown here; mulberry trees, potatoes, figs, and herbs of different kinds; honey and wax are made; there are good fresh-water fish, particularly trout; horses suited for light cavalry, many mules and asses, a fine species of horned cattle, numerous flocks of sheep, shepherds' dogs remarkable for their size and extraordinary strength, pigs, goats, poultry, especially geese, bees, &c. Iron mines are found; and quarries of asbestos, granite, ochre, marble, granite, marle, fullers' earth, potters' clay, &c. There are establishments of mineral waters at Bagnères de Biorre, Barèges, Cauterets, Luz, Cadeac, Capoerne, Siradan, and St. Marie. Manufactures are carried on here, of bolting-cloths, twine, serge, linen cloths, light stuffs, crapes, shawls, cudgels, agricultural instruments, cutlery, nails, leather, coarse paper, and brandy; and there is a considerable trade in excellent butter, cheese, honey, provisions of all kinds, sheep and lambs, pigs, hams, poultry, wood, timber for coopers, hoops, wooden shoes, &c.

The principal rivers that water this department are the Adour, the Garonne, the Neste, the Gers,

the Gave de Pau, the Arros, and the Estreux; and it is crossed by the great roads of Pau, Auch, and Mont-de-Marsan.

PYRENEES, DEPARTMENT OF THE EASTERN, is formed out of the ancient province of Roussillon, and takes its name from the eastern part of the Pyrenean Mountains, among which it is situated. The principal place of this prefecture is Perpignan, and it is divided into three arrondissements or sub-prefectures; containing a population of 133,446 souls, on a superficial extent of 1908 square miles; and yielding a territorial revenue of 7,351,000 francs. These are subdivided into seventeen cantons and 248 communes, and consist of two electoral arrondissements, that send two members to the chamber of deputies. It forms part of the tenth military division, in the diocese of Carcassonne, and has a royal court at Montpellier. This department is bounded on the north by that of the Aude; on the east by the Mediterranean; on the south by the Pyrenean Mountains, which divide France from Spain; and on the west by the department of the Arriege.

This country is intersected with lofty mountains, which join on the Pyrenean chain, and are the highest of all the range between the Mediterranean and the Ocean. They are covered with snow and ice, and give rise to a great number of rivers, which, on account of their great declivity, are destitute of water for one part of the year; but in the rainy season, or when the snows are melted, they become impetuous torrents, the overflowing of which often causes dreadful ravages. The surface is divided into three great basins by the Tet, the Tech, the Agly, and the Aude, and generally affords a fertile soil, suitable for every purpose of agriculture. There are commonly two harvests in those lands which are watered. The hedges are formed in a great measure of pomegranate trees; orange and citron trees flourish every where in the open field; and the hills and uncultivated parts are covered with thyme, rosemary, creeping thyme, lavender, juniper, and mulberry trees. The climate is rather warm; the winter here is a kind of spring; the heat is sometimes very great in summer, and in some cantons the air would be rather unhealthy, were it not often purified by a wind from the north-west called tramontane. The soil is cultivated with mules, and yields a full supply for its inhabitants: there are 47,229 hectares of forests, chiefly firs, pines, and beech; and 35,500 hectares of vineyards, yielding an average produce of sixteen francs thirty centimes on each hectare of arable land.

The productions are wheat, barley, millet, maize, vegetables, melons, excellent fruits, flax, hemp, oak, kermes, wood, salt-marshes, wine, fine honey, mulberries, olives, lavender, &c., small game, sea fish in abundance, mules, some cows, numerous flocks of merino sheep (famed for the flavor of their flesh and the fineness of their wool), poultry, bees, silk-worms, cachemire goats, &c. There are also mines of iron, antimony, and coal, and quarries of white and colored marble, limestone, &c. They have hot baths at Arles, Molitg, Lapreste, Escaldes, and Vernet. The manufactures consist of common cloth, wool-

len stuffs and caps, corks, forged iron, and leather; and a trade is carried on in all the above articles.

The principal rivers that water the department are the Tet, the Tech, the Gly, the Cantarana, the Reart, and the Segrè; and it is crossed by the great roads of Narbonne, Figuières, and Payarda.

PYRENEES, a great chain of mountains separating France from Spain, and extending from the port of Vendres on the coast of the Mediterranean to the Atlantic Ocean near Fontarabia. It is about 210 miles long; its direction is nearly from S. S. E. to N. N. W.; and both on the side of Spain and that of France it consists of several parallel ridges, varying in breadth from sixty to 120 miles. On the side of France these mountains project several branches, which run through those departments that are on the Spanish frontier. The two most considerable of these are that which crosses the departments of the Arriege and the Aude, and unites with the Alps near Castelnaudary, and that which, crossing the departments of the Upper Pyrenees and the Gers, terminates on the borders of the departments of the Landes and the Gironde. Next to the Alps these are the highest mountains in Europe; they rise gradually to the top, which serves as a point of demarcation, and at the two extremities sink in elevation down to the level of the Ocean and the Mediterranean. The highest summits of the chain are, according to M. Humboldt, the top of Nethon about 10,722 feet above the level of the sea, Posets 10,584 feet, Mount Perdu 10,576, Le Cylindre 10,374, the pic-du-Midi 8958, and Canigou 8946 feet.

The Pyrenees are less steep on the French side than on that of Spain; the most elevated summits are covered with snow during a great part of the year, and at the height of 7200 the snows never melt, but occupy a zone of from 3000 to 3600 feet, that resists all the rays of the sun; on the north and west, however, they almost always melt. From Marbore to Maladetta there is a great number of glaciers, which the eye can distinguish afar off by their bluish tint, by their even appearance, and by the clefts which cross them. The air of the higher mountains is as unwholesome as that of the lower ones is healthy. In the month of May impetuous cataracts precipitate themselves on all sides from the tops of the Pyrenees, and inundations caused by the sudden melting of the snows and the abundant rains soon fill up all the close valleys. Trees broken by the violence of the winds often choke the course of the torrents, or, carried away themselves, drag with them the crops and the houses hanging on the declivity of the mountains. Enormous masses of rocks, which appeared immovable, are now dashed from steep to steep, carrying every thing before them. To these avalanches we may add those which are occasioned in the winter by the abundant snows, which the storms loosen from the summits and precipitate into the ravines, and which increasing in size as they advance, and dragging with them masses of stone and earth, sometimes form bridges over the torrents and fill up the valleys. Often they are accompanied with a tremendous hissing; nothing

can resist their force; and the agitation of the air which they produce is so violent that every obstacle to their progress is overturned. In the neighbourhood of Baréges whole villages have sometimes been thus overwhelmed.

No country is richer in natural productions than that of the Pyrenees; the geologist may find here numberless beauties, and ever fresh sources of instruction; the mineralogist a multitude of the most curious minerals; the botanist, passing in the same day from the greatest heat to the most intense cold, meets in his way every species of plants, from those which grow in the Alps and in Sweden to those which flourish in Spain. In the middle part mineral springs abound; but, though some are of great efficacy, they are little used. The most celebrated, and which have establishments greatly frequented, are the baths of Mollitg, Baréges, Bagnères, Arles, Vernet, La Preste, Ax, Cambo, Cauterets, Nossa, Olette, Nyer, and the warm springs of the Cerdagne, generally known by the name of Lascaldas.

Since the above has been prepared for press our attention has been directed to the Geological Conjectures of Mr. Charpentier, director of the Canton de Vaud mines, respecting the original form and construction of the Pyrenees. The following is an abstract of them as given in his *Essai sur la Constitution Geogrostique des Pyrenees*, a very sensible and distinguished performance.

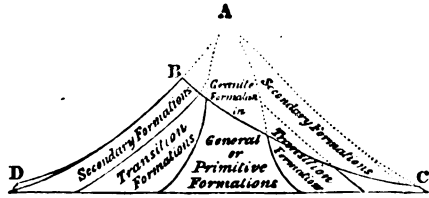
‘We have seen,’ says this writer, ‘that the different formations are disposed in bands parallel to each other and parallel to the general direction of the Pyrenees; that the granite forms only a single band, or, speaking more correctly, a chain or series of protuberances; that each of the other formations constitutes in general two bands, one of which is situated to the north, the other to the south of the granitic chain, resting upon it in the order of their relative antiquity; that many of these granitic protuberances are separated from one another by valleys, while others, on the contrary, are, as it were, agglutinated by rocks of later origin, which have filled up the spaces or vacuities by which they were formerly separated; and, lastly, that it is commonly in the spaces which exist between two great protuberances that we observe the bands that occur to the south of the granitic chain, touching and mingling with those which occur to the north. These facts entitle us to presume that the granitic formation, comprising that of mica-slate and primitive limestone, formed originally an uninterrupted chain, or rather an elongated line, having a direction from south-east to north-west, and being of a height, whether absolute or relative, much greater than at the present day; that at a period anterior to the formation of the other rocks which recline upon it, this granitic chain has undergone degradations caused by a power (perhaps currents of water) which, acting horizontally from south to north, or from north to south, has broken its ridge in many parts, scooped it out to a great depth, and changed it into a series of more or less isolated eminences; that the rocks formed after this revolution have been applied on each side against this central granitic chain, have filled up its deepest hollows, and have even cover-

ed its lowest protuberances; and that, lastly, immediately after this revolution, the ridge of the primitive formation was, without doubt, at the same time that of the whole chain of the Pyrenees.

‘Now, as we observe at the present day that the ridge of the Pyrenees, with the exception of a small number of places, is no longer the ridge of the granitic chain, which is found removed at some distance to the north; but that this geographic ridge is composed of more modern rocks, which generally surpass the primitive formation in height, we are naturally led to presume that the Pyrenees have undergone a second very considerable degradation. The disposition of the rocks, and the external form of the mountains, appear to determine the period of this revolution. It is probable that it has taken place after the formation of the transition deposit, and before the excavation of the presently existing valleys, and consequently before the deposition of the trap formation, which, as we shall see in the sequel, appears to be of a very late origin.

‘Observation tends to induce a presumption that this degradation has principally attacked the ridge then existing, and all the northern aspect of the chain. We shall represent by a diagram the results which have given rise to this supposition.

‘The figure shows the vertical and transverse



section A B C of the Pyrenees in the direction of their breadth, such as we presume it to have been before these mountains underwent the degradation of which we have been speaking. We see in this section the two declivities A B and A D of equal size; the granite occupying the centre, and forming the ridge of the chain; the transition formation, and the secondary formation, distributed in nearly equal quantities upon the south and north sides, resting upon the granite. Let us now suppose that all the portion of these mountains situated between A, B, and C, has been destroyed by the effect of some power acting from north to south, in such a manner that there remains only the part situated between C, B, and D.

‘The necessary consequence of this degradation would be a considerable change in the external form of the whole chain of mountains, and especially in the disposition and distribution of the rocks with relation to the external form of the chain; in short, this revolution would produce a multitude of results and accidents which are observed in the Pyrenees, and of which we shall recapitulate the chief.

‘There would result from the destruction of all the parts situated between A, B, and C, 1st, That the ridge would be lowered; and, further,



that its position would be removed more to the south, and that consequently the northern aspect B, C, would become longer and more sloping than the southern one B D. 2dly, That the granite, including the other primitive rocks, would no longer form the ridge of the central chain, to the north of which it would occur at a short distance. 3dly, That the southern bands of the secondary and transition formations would obtain a height which would in general surpass that of the granite and that of all the other rocks situated to the north of the primitive formation. 4thly, That these two southern bands would, in general, form the ridge of the whole system. 5thly, That the transition formation would be much more diffused, or, at least, would appear to a much greater extent, upon the north side than upon the southern declivity. 6thly, That the secondary formation would occupy all the southern declivity, while, on the northern side, it would only form the low mountains at the foot of the chain.

'We here see how well the necessary results of the supposition which we have admitted accord with the actual phenomena. Several other observations would further lead us to presume, that, independently of the great revolution of which we have been speaking, the northern part of the Pyrenees must have undergone, previously to the formation of the present valleys, a new degradation of considerable extent; such, for example, are the generally softer and more rounded forms of the northern, compared with the southern mountains; the more considerable number of basins in the French valleys than in those of the Spanish side; and the immense deposits of transported rocks, of which the soil of the plains which extend from the north side of the Pyrenees is formed.'

**PYRIFORMIS**, banksia, in botany, a species of *BANKSIA*, which see. It was unknown to Linné; and Gaertner, who has mentioned it, gives no specific character of it. It has solitary flowers, ovate downy capsules, and lance-shaped entire smooth leaves: CAPS. larger than in any other known species.

**PYRMONT**, a district in the north-west of Germany, between Hanover in the north, and the Prussian government of Minden, in Westphalia, in the south. It belongs to prince Waldec, with the title of a county, but has an area of only thirty-six square miles, with 4300 inhabitants; of the prince's income (about £10,000), the larger half arises from the mineral springs of

**PRAMONT**, the chief town of the above principality. It contains 2000 inhabitants, and is situated in a pleasant valley, with public walks, and houses adapted to the accommodation of visitors. Thirty-three miles S. S. W. of Hanover, and sixteen south-east of Rinteln.

**PYROCITRIC ACID**, in chemistry. When citric acid is put to distil in a retort, it begins at first by melting; the water of crystallisation separates almost entirely from it by a continuance of the fusion; then it assumes a yellowish tint, which gradually deepens. At the same time there is disengaged a white vapor which goes over, to be condensed in the receiver. Towards

the end of the calcination a brownish vapor is seen to form, and there remains in the bottom of the retort a light very brilliant charcoal.

The product contained in the receiver consists of two different liquids. One of an amber-yellow color, and an oily aspect, occupies the lower part; another, colorless, and liquid like water, of a very decided acid taste, floats above. After separating them from one another, we perceive that the first has a very strong bituminous odor, and an acid and acrid taste; that it reddens powerfully the tincture of litmus, but that it may be deprived almost entirely of that acidity by agitation with water, in which it divides itself into globules, which soon fall to the bottom of the vessel, and are not long in uniting into one mass, in the manner of oils heavier than water.

In this state it possesses some of the properties of these substances; it is soluble in alcohol, ether, and the caustic alkalis. However, it does not long continue thus; it becomes acid, and sometimes even it is observed to deposit, at the end of some days, white crystals, which have a very strong acidity; if we then agitate it anew with water, it dissolves in a great measure, and abandons a yellow or brownish pitchy matter, of a very obvious empyreumatic smell, and which has much analogy with the oil obtained in the distillation of other vegetable matters. The same effect takes place when we keep it under water; it diminishes gradually in volume, the water acquires a sour taste, and a thick oil remains at the bottom of the vessel.

This liquid may be regarded as a combination (of little permanence indeed) of the peculiar acid with the oil formed in similar circumstances.

This acid is white, inodorous, of a strongly acid taste. It is difficult to make it crystallise in a regular manner, but it is usually presented in a white mass, formed by the interlacement of very fine small needles. Projected on a hot body it melts, is converted into white very pungent vapors, and leaves some traces of carbon. When heated in a retort, it affords an oily-looking acid, and yellowish liquid, and is partially decomposed. It is very soluble in water and in alcohol; water at the temperature of 10° C. (50° F.) dissolves one-third of its weight. The watery solution has a strongly acid taste, it does not precipitate lime or barytes water, nor the greater part of metallic solutions, with the exception of acetate of lead and protonitrate of mercury. With the oxides it forms salts possessing properties different from the citrates.

The pyrocitrate of potash crystallises in small needles, which are white, and unalterable in the air. It dissolves in about four parts of water. Its solution gives no precipitate with the nitrate of silver, or of barytes; whilst that of the citrate of barytes forms precipitates with these salts.

The pyrocitrate of lime directly formed exhibits a white crystalline mass, composed of needles, opposed to each other in a ramification form. This salt has a sharp taste.

**PYROLA**, in botany, winter green, a genus of the monogynia order, and decandria class of plants; natural order eighteenth, bicornos: CAT.

quinquepartite; petals five: caps. is quinquelocular, opening at the angles.

**PYROLIGNEOUS ACID**, in chemistry, is the destructive distillation of any kind of wood an acid is obtained, which was formerly called acid spirit of wood, and since pyroligneous acid. Fourcroy and Vanquelin showed that this acid was merely the acetic, contaminated with empyreumatic oil and bitumen. See **ACETIC ACID**, **CHEMISTRY**, and **VINEGAR**.

**PYROLITHIC ACID**, in chemistry. 'When uric acid concretions are distilled in a retort, silvery white plates sublime. These are pyrolithate of ammonia. When their solution is poured into that of subacetate of lead, a pyrolithate of lead falls, which, after proper washing, is to be shaken with water, and decomposed by sulphureted hydrogen gas. The supernatant liquid is now a solution of pyrolithic acid, which yields small acicular crystals by evaporation. By heat, these melt and sublime in white needles. They are soluble in four parts of cold water, and the solution reddens vegetable blues. Boiling alcohol dissolves the acid, but on cooling it deposits it, in small white grains. Nitric acid dissolves without changing it. Hence, pyrolithic is a different acid from the lithic, which, by nitric acid, is convertible into purpurate of ammonia. The pyrolithate of lime crystallises in stalactites, which have a bitter and slightly acrid taste. It consists of 91.4 acid + 8.6 lime. Pyrolithate of barytes is a nearly insoluble powder. The salts of potassa, soda, and ammonia, are soluble, and the former two crystallisable. At a red heat, and by passing it over ignited oxide of copper, it is decomposed, into oxygen 44.32, carbon 28.29, azote 16.84, hydrogen 10.'

**PYROMALIC ACID**, in chemistry, when malic or sorbic acid, for they are the same, is distilled in a retort, an acid sublimate, in white needles, appears in the neck of the retort, and an acid liquid distils into the receiver. This liquid, by evaporation, affords crystals, constituting a peculiar acid, to which the above name has been given.

They are permanent in the air, melt at 118° Fahrenheit, and on cooling form a pearl-colored mass of diverging needles. When thrown on red-hot coals, they completely evaporate in an acrid, cough-exciting smoke. Exposed to a strong heat, in a retort, they are partly sublimed in needles, and are partly decomposed. They are very soluble in strong alcohol, and in double their weight of water, at the ordinary temperature. The solution reddens vegetable blues, and yields white flocculent precipitates with acetate of lead and nitrate of mercury; but produces no precipitate with lime water. By mixing it with barytes water, a white powder falls, which is redissolved by dilution with water, after which, by gentle evaporation, the pyromalate of barytes may be obtained in silvery plates. These consist of 100 acid, and 185.142 barytes, or, in prime equivalents, of 5.25 + 9.75.

Pyromalate of potash may be obtained in feather formed crystals, which deliquesce. Pyromalate of lead forms first a white flocculent precipitate, soon passing into a semi-transparent jelly, which, by dilution and filtration from the

water, yields brilliant pearly looking needles. The white crystals that sublime in the original distillation are considered by M. Lassaigue as a peculiar acid.

**PYROMETER**, from *πυρ*, fire, and *μετρον*, measure. To measure those higher degrees of heat to which the thermometer cannot be applied there have been other instruments invented by different philosophers: these are called pyrometers. The most celebrated instrument of this kind, and which has been adopted into general use, is that invented by the late ingenious Mr. Wedgwood.

This instrument is also sufficiently simple. It consists of two pieces, of brass fixed on a plate, so as to be six-tenths of an inch asunder at one end, and three-tenths at the other; a scale is marked upon them, which is divided into 240 equal parts, each one-tenth of an inch; and with this his gauge, are furnished a sufficient number of pieces of baked clay, which must have been prepared in a red heat, and must be of given dimensions. These pieces of clay, thus prepared, are first to be applied cold to the rule of the gauge, that there may no mistake take place in regard to their dimensions. Then any one of them is to be exposed to the heat which is to be measured, till it shall have been completely penetrated by it. It is then removed and applied to the gauge. The difference between its former and its present dimensions will show how much it has shrunk; and will consequently indicate to what degree the intensity of the heat to which it was exposed amounted.

High temperatures can thus be ascertained with accuracy. Each degree of Wedgwood's pyrometer is equal to 130° of Fahrenheit's.

Mr. Wedgwood sought to establish a correspondence between the indications of his pyrometer and those of the mercurial thermometer, by employing a heated rod of silver, whose expansions he measured, as their connecting link. The clay-piece and silver rod were heated in a muffle.

When the muffle appeared of a low red heat, such as was judged to come fully within the province of the thermometer, it was drawn forward toward the door of the oven; and, its own door being then nimbly opened by an assistant, Mr. Wedgwood pushed the silver piece as far as it would go. But, as the division which it went to could not be distinguished in that ignited state, the muffle was lifted out, by means of an iron rod passing through two rings made for that purpose with care to keep it steady, and avoid any shake that might endanger the displacing of the silver piece.

When the muffle was grown sufficiently cold to be examined, he noted the degree of expansion which the silver piece stood at, and the degree of heat shown by the thermometer pieces measured in their own gauge; then returned the whole into the oven as before, and repeated the operation with a stronger heat, to obtain another point of correspondence on the two scales.

The first was at 2½° of his thermometer, which coincided with 66° of the intermediate one; and, as each of these last had been before found to contain 20° of Fahrenheit's, the 66° will contain

1320; to which add 50, the degree of his scale to which the (0) of the intermediate thermometer was adjusted, and the sum 1370 will be the degree of Fahrenheit's corresponding to his 21°.

The second point of coincidence was at 6¼° of his, and 92° of the intermediate; which 92° being, according to the above proportion, equivalent to 1840 of Fahrenheit, add 50 as before to this number, and his 6¼° is found to fall upon the 1890° of Fahrenheit.

It appears hence that an interval of 4° upon Mr. Wedgwood's thermometer is equivalent to an interval of 520° upon that of Fahrenheit; and, consequently, one of the former to 130° of the latter; and that the (0) of Mr. Wedgwood corresponds to 1077¼° of Fahrenheit.

From these data it is easy to reduce either scale to the other through their whole range; and from such reduction it will appear, that an interval of nearly 480° remains between them, which the intermediate thermometer serves as a measure for; that Mr. Wedgwood's includes an extent of about 32,000 of Fahrenheit's degrees, or about fifty-four times as much as that between the freezing and boiling points of mercury, by which mercurial ones are naturally limited; that if the scale of Mr. Wedgwood's thermometer be produced downward in the same manner as Fahrenheit's has been supposed to be produced upward, for an ideal standard, the freezing point of water would fall nearly on 8° below (0) of Mr. Wedgwood's, and the freezing point of mercury a little below 8¼°; and, that, therefore, of the extent of now measurable heat, there are about five-tenths of a degree of his from the freezing of mercury to the freezing of water; 8° from the freezing of water to full ignition; and 160° above this to the highest degree he has hitherto attained.

Mr. Wedgwood concludes his account with the following table of the effects of heat on different substances, according to Fahrenheit's thermometer and his own:—

	Fahr.	Wedg.
• Extremity of the scale of his thermometer . . . . .	32277°	240
Greatest heat of his small air furnace . . . . .	21877	160
Cast-iron melts . . . . .	17977	130
Greatest heat of a common smith's forge . . . . .	17327	125
Welding heat of iron greatest . . . . .	13427	95
Welding heat of iron least . . . . .	12777	90
Fine gold melts . . . . .	5237	32
Fine silver melts . . . . .	4717	28
Swedish copper melts . . . . .	4587	27
Brass melts . . . . .	3807	21
Heat by which his enamel colors are burnt on . . . . .	1857	6
Red heat fully visible in day-light . . . . .	1077	0
Red heat fully visible in the dark . . . . .	947	— 1
Mercury boils . . . . .	600	3 <sup>17</sup> / <sub>100</sub>
Water boils . . . . .	212	6 <sup>17</sup> / <sub>100</sub>
Vital heat . . . . .	97	7 <sup>17</sup> / <sub>100</sub>
Water freezes . . . . .	32	8 <sup>17</sup> / <sub>100</sub>
Proof spirit freezes . . . . .	0	8 <sup>17</sup> / <sub>1000</sub>

The point at which mercury congeals, consequently the limit of mercurial thermometers, about . . . . . 40 8 <sup>17</sup>/<sub>100</sub>

**PYROMUCIC ACID.** This acid, discovered in 1818 by M. Houton Labillardiere, is one of the products of the distillation of mucic acid. When we wish to procure it, the operation must be performed in a glass retort furnished with a receiver. The acid is formed in the brown liquid, which is produced along with it, and which contains water, acetic acid, and empyreumatic oil; a very small quantity of the pyromucic acid remaining attached to the vault of the retort under the form of crystals. These crystals, being colored, are added to the brown liquor, which is then diluted with three or four times its quantity of water, in order to throw down a certain portion of oil. The whole is next filtered, and evaporated to a suitable degree. A great deal of acetic acid is volatilised, and then the new acid crystallises. On decanting the mother waters, and concentrating them farther, they yield crystals anew; but, as these are small and yellowish, it is necessary to make them undergo a second distillation to render them susceptible of being perfectly purified by crystallisation; 150 parts of mucic acid furnish about sixty of brown liquor, from which we can obtain eight to ten of pure pyromucic acid.

This acid is white, inodorous, of a strongly acid taste, and a decided action on litmus. Exposed to heat in a retort it melts at the temperature of 266° Fahrenheit, then volatilises, and condenses into a liquid, which passes on cooling into a crystalline mass, covered with very fine needles. It leaves very slight traces of residuum in the bottom of the retort.

On burning coals, it instantly diffuses white pungent vapors. Air has no action on it. Water at 60° dissolves one-twenty-eighth of its weight. Boiling water dissolves it much more abundantly, and on cooling abandons a portion of it, in small elongated plates, which cross in every direction.

**PYROPHORUS.** By this name is denoted an artificial product, which takes fire or becomes ignited on exposure to the air. Hence, in the German language, it has obtained the name of luft-zunder, or air-tinder. It is prepared from alum by calcination, with the addition of various inflammable substances. Homburg was the first that obtained it, which he did accidentally in the year 1680, from a mixture of human excrement and alum, upon which he was operating by fire.

The preparation is managed in the following manner:—Three parts of alum are mixed with from two to three parts of honey, flour, or sugar; and this mixture is dried over the fire in a glazed bowl, or an iron pan, diligently stirring it all the while with an iron spatula. At first this mixture melts, but by degrees it becomes thicker, swells up, and at last runs into small dry lumps. These are triturated to powder, and once more roasted over the fire, till there is not the least moisture remaining in them, and the operator is well assured that it can liquefy no more: the mass now looks like a blackish powder of charcoal. For the sake of avoiding the previous above men-

tioned operation, from four to five parts of burned alum may be mixed directly with two of charcoal powder. This powder is poured into a phial or matrass, with a neck about six inches long. The phial, which however must be filled three-quarters full only, is then put into a crucible, the bottom of which is covered with sand, and so much sand is put round the former that the upper part of its body also is covered with it to the height of an inch: upon this the crucible, with the phial, is put into the furnace, and surrounded with red-hot coals. The fire, being now gradually increased till the phial becomes red-hot, is kept up for the space of about a quarter of an hour, or till a black smoke ceases to issue from the mouth of the phial, and instead of this a sulphureous vapor exhales, which commonly takes fire. The fire is kept up till the blue sulphureous flame is no longer to be seen;

upon this the calcination must be put an end to, and the phial closed for a short time with a stopper of clay or loam. But, as soon as the vessel is become so cool as to be capable of being held in the hand, the phial is taken out of the sand, and the powder contained in it transferred as fast as possible from the phial into a dry and stout glass made warm, which must be secured with a glass stopper.

We have made a very good pyrophorus by simply mixing three parts of alum with one of wheat-flour, calcining them in a common phial till the blue flame disappeared; and have kept it in the same phial, well stopped with a good cork when cold.

If this powder be exposed to the atmosphere, the sulphuret attracts moisture from the air, and generates sufficient heat to kindle the carbonaceous matter mingled with it.

## P Y R O T E C H N Y .

**PYR'OTECHNY, n. s.** Fr. *pyrotechnie*. The art of managing fire, or making fire-works.

Great discoveries have been made by the means of *pyrotechny* and chymistry, which in late ages have attained to a greater height than formerly.

*Hale's Origin of Mankind.*

**PYROTECHNY**, of Greek, *πυρ*, fire, and *τεχνη*, art, is a term that has been applied to all kinds of artificial fire-works, including those of a military description; but of late it has been more commonly restricted to those fire-works which are constructed for amusement, or are used in public demonstrations of joy: and it is in this sense we shall consider it in this article.

These are inventions which, though they seem to have been for ages familiar to the Chinese and other nations of the eastern world, were brought at a recent period only into Europe by way of Italy; and the Italian and French artists long bore away the palm in their construction. The late Sir William Congreve, however, at the period of the peace of 1815, seemed suddenly to rise like one of his own rockets, above our foreign competitors; and with the aid of his majesty's parks, the public purse, the sheet of water in St. James's park, and the never-to-be-forgotten Chinese bridge over the said water, to have attained the most brilliant honors in this art. We believe all his principal devices will be found included in the descriptive account of modern fire-works here following:—

### PART I.

#### SMALLER AND MISCELLANEOUS FIRE-WORKS.

1. *Of the Chinese fire.*—In honor of the Chinese we begin with the brilliant fire sometimes called *Chinese fire*. Iron filings, when thrown into the fire, inflame and emit a strong light. This property, discovered perhaps by chance, gave rise to the idea of rendering the fire of rockets, and

other pyrotechnical inventions, much more brilliant than when gunpowder, or the substances of which it is composed, are alone employed. Nothing is necessary but to take iron filings, very clean and free from dust, and to mix them with the ordinary composition. It must, however, be observed, that works of this kind will not keep longer than a week; because the moisture contracted by the saltpetre rusts the iron filings.

The Chinese have long been in possession of a method of rendering this fire much more brilliant and variegated in its colors; and we are indebted to father d'Incarville, a jesuit, for having made it known. It consists in the use of a simple ingredient, namely, cast iron reduced to a powder more or less fine: the Chinese gave it a name which is equivalent to that of *iron sand*. To prepare this sand take an old iron pot, and, having broken it to pieces on an anvil, pulverise the fragments till the grains are not larger than radish seed; then sift them through six graduated sieves, to separate the different sizes; and preserve these six different kinds in a very dry place, to secure them from rust, which would render this sand absolutely unfit for the proposed end. We must here remark that the grains which pass through the closest sieve are called sand of the first order; those which pass through the next in size, sand of the second order; and so on.

This sand, when it inflames, emits a light exceedingly vivid. It is very surprising to see fragments of this matter no bigger than a poppy seed form all on a sudden luminous flowers or stars, twelve and fifteen lines in diameter. These flowers are also of different forms, according to that of the inflamed grain, and even of different colors, according to the matters with which the grains are mixed. Rockets which contain the finest sand will not keep longer than eight days, and those which contain the coarsest, fifteen. The following tables exhibit the proportions of the different ingredients for rockets of from twelve to thirty-six pounds.

*For red Chinese fire*

Calibres.	Salt petre.	Sulphur.	Charcoal.	Sand of the 1st order.
lbs.	lbs.	oz.	oz.	oz. dr.
12 to 15	1	3	4	7
18 to 21	1	3	5	7 8
24 to 36	1	4	6	8

*For white Chinese fire.*

Calibres.	Salt- petre.	Bruised Gun- powder.	Charcoal.	Sand of the 3d order.
lbs.	lbs.	oz.	oz. dr.	oz. dr.
12 to 15	1	12	7 8	11
18 to 21	1	11	8	11 8
24 to 36	1	11	8 8	12

When these materials have been weighed, the saltpetre and charcoal must be three times sifted through a hair sieve, in order that they may be well mixed: the iron sand is then to be moistened with good brandy, to make the sulphur adhere, and they must be thoroughly incorporated. The sand thus sulphured must be spread over the mixture of saltpetre and charcoal, and the whole must be mixed together by spreading it over a table with a spatula.

2. *A shower of fire.*—To form a shower of fire, mould small paper cartridges on an iron rod two lines and a half in diameter, and make them two inches and a half in length. They must not be choked, it being sufficient to twist the end of the cartridge, and having put the iron rod into it to beat it, in order to make it assume its proper form. When the cartridges are filled, which is done by immersing them in the composition, fold down the other end, and then apply a match. This will fill the surrounding air with an undulating fire. The following compositions are given as proper for meteors of this kind. 1. *Chinese fire.*—Mealed gunpowder one pound, sulphur two ounces, iron-sand of the first order five ounces. 2. *Ancient fire.*—Mealed gunpowder one pound, charcoal two ounces. 3. *A brilliant fire.*—Mealed gunpowder one pound, iron-filings four ounces. The first of these compositions is thought to be the most beautiful.

3. *Sparks*, differing only from stars in their size and duration, are thus prepared:—Put into an earthen vessel an ounce of mealed gunpowder, two ounces of pulverised saltpetre, one ounce of liquid saltpetre, and four ounces of camphor reduced to powder; pour over this mixture some gum-water, or brandy in which gum has been dissolved, till the composition becomes of the consistence of thick soup. Then take some lint which has been soaked in brandy, or in vinegar, or even in a solution of saltpetre, and, being dried and unravelled, throw into the mixture such a quantity of it as is sufficient to absorb it entirely, taking care to stir it well. This composition may be formed into small balls about the size of a pea, and being dried in the shade, and sprinkled with mealed powder, they will readily catch fire.

Sparks may also be made thus:—Take saw-dust of fir, poplar, &c., and boil it in water in which saltpetre has been dissolved. When the water has boiled some time, it is to be poured off, that the saw-dust may remain in the vessel. When nearly dry, it is to be spread out on a table, and sprinkled with sulphur sifted through a very fine sieve, to which may be added a little mealed powder.

4. *Golden rain.*—Some rockets, which, as they fall, make small undulations in the air, called by French writers fusées chevelues, and by us bearded rockets, finish with a kind of shower of fire, which is called golden rain, thus constructed:—Fill the barrels of some goose quills with the composition of flying rockets (for which see onward), and place upon the mouth of each a little moist gunpowder, both to keep in the composition, and to serve as a match. If flying rockets be then loaded with these quills, the explosion of them will terminate in a beautiful shower of fire, to which the name of golden rain has been given.

5. *Globes which burn on the water.*—To make a spherical fire ball, construct a hollow wooden globe of any size, and let its thickness be about one-ninth of its diameter. Into the upper hemisphere insert a right concave cylinder, the breadth of which may be equal to one-fifth of the diameter. A petard, loaded with good grained gunpowder, is to be introduced at the bottom of it, and to be placed horizontally; then the aperture is closed with a wooden tompion dipped in pitch, and over the whole of this part a quantity of lead is melted sufficient to make the globe sink: if the globe be now placed in the water, the lead by its gravity will make the aperture tend directly downwards, and keep in a perpendicular direction the cylinder, to which fire must have been previously applied. To ascertain whether the lead, which has been added to the globe, renders its weight equal to that of an equal volume of water, rub the globe over with pitch or grease, and make a trial, by placing it in the water.

The composition with which the globe must be loaded is as follows: to a pound of grained powder add thirty-two pounds of saltpetre reduced to fine flour, eight pounds of sulphur, one ounce of scrapings of ivory, and eight pounds of saw-dust previously boiled in a solution of saltpetre, and dried in the shade, or in the sun. Or to two pounds of bruised gunpowder add twelve pounds of saltpetre, six pounds of sulphur, four pounds of iron filings, and one pound of Greek pitch.

It is not necessary that this composition should be beaten so fine as that intended for rockets: it requires neither to be pulverised nor sifted; it is sufficient to be well mixed and incorporated. But, to prevent it from becoming too dry, it will be proper to besprinkle it with a little oil, or any other liquid susceptible of inflammation.

6. *Of globes which leap or roll on the ground.*—Having constructed a wooden globe with a cylinder similar to the above described, and having loaded it with the same composition, introduce into it four petards, or even more, loaded with good grained gunpowder to their orifices, which must be well stopped with paper or tow.

If a globe, prepared in this manner, be fired by means of a match, it will leap about, as it burns, on a smooth, horizontal plane, according as the petards are set on fire. Instead of placing these petards in the inside, they may be affixed to the exterior surface of the globe; which they will make to roll and leap as they catch fire. They may be applied in any manner to the surface of the globe.

7. A similar globe may be made to roll about on a horizontal plane, with a very rapid motion. Construct two equal hemispheres of pasteboard, and adjust in one of them three common rockets filled and pierced like flying rockets that have no petard: these rockets must not exceed the interior breadth of the hemisphere, and ought to be arranged in such a manner that the head of the one shall correspond to the tail of the other. The rockets being arranged, join the two hemispheres, by cementing them together with strong paper, in such a manner that they shall not separate, while the globe is moving and turning, at the same time that the rockets produce their effect. To set fire to the first, make a hole in the globe opposite to the tail of it, and introduce into it a match. This match will communicate fire to the first rocket; which, when consumed, will set fire to the second by means of another match, and so on to the rest; so that the globe, if placed on a smooth horizontal plane, will be kept in continual motion. It is here to be observed that a few more holes must be made in the globe, otherwise it will burst.

The two hemispheres of pasteboard may be prepared in the following manner:—Construct a very round globe of solid wood, and cover it with melted wax; then cement over it several bands of coarse paper, about two inches in breadth, giving it several coats of this kind, to the thickness of about two lines. Or, which will be still easier and better, having dissolved, in glue water, some of the pulp employed by the paper-makers, cover with it the surface of the globe; then dry it gradually at a slow fire, and cut it through in the middle; by which means you will have two strong hemispheres. The wooden globe may be easily separated from the pasteboard by means of heat; for if the whole be applied to a strong fire the wax will dissolve, so that the globe may be drawn out: instead of melted wax, soap may be employed.

8 *Of aerial globes, called bombs.*—These globes are called aerial because they are thrown into the air from a mortar, which is a short thick piece of artillery of a large calibre. And though these globes are of wood, and have a suitable thickness, namely, equal to the twelfth part of their diameters, if too much powder be put into the mortar they will not be able to resist its force; the charge of powder therefore must be proportioned to the globe to be ejected. The usual quantity is an ounce of powder for a globe of four pounds weight; two ounces for one of eight, and so on.

As the chamber of the mortar may be too large to contain the exact quantity of powder sufficient for the fire-ball, which ought to be placed immediately above the powder, in order that it may be expelled and set on fire at the same time, another mortar may be constructed of wood, or of

pasteboard with a wooden bottom: it ought to be put into a large iron mortar, and to be loaded with a quantity of powder proportioned to the weight of the globe. This small mortar must be of light wood, or of paper pasted together, and rolled up in the form of a cylinder, or truncated cone, the bottom excepted; which, as already said, must be of wood. The chamber for the powder must be pierced obliquely, with a small gimlet; so that, the aperture corresponding to the aperture of the metal mortar, the fire applied to the latter may be communicated to the powder which is at the bottom of the chamber, immediately below the globe. By this means the globe will catch fire, and make an agreeable noise as it rises into the air; but it would not succeed so well if any vacuity were left between the powder and the globe.

A profile or perpendicular section of such a globe is represented by the right-angled parallelogram, the breadth of which is nearly equal to the height. The thickness of the wood, towards the two sides, is equal, as above said, to the twelfth part of the diameter of the globe; and the thickness of the cover is double the preceding, or equal to a sixth part of the diameter. The height of the chamber where the match is applied, and which is terminated by a semicircle, is equal to the fourth part of the breadth; and its breadth is equal to the sixth part. We must here observe that it is dangerous to put wooden covers on aerial balloons or globes; for these covers may be so heavy as to wound those on whom they happen to fall. It will be sufficient to place turf or hay above the globe, in order that the powder may experience some resistance.

The globe must be filled with several pieces of cane or common reed, equal in length to the interior height of the globe, and charged with a slow composition, made of three ounces of pounded gunpowder, an ounce of sulphur moistened with a small quantity of petroleum oil, and two ounces of charcoal; and in order that these reeds or canes may catch fire sooner, and with more facility, they must be charged at the lower ends, which rest on the bottom of the globe, with pulverised gunpowder moistened in the same manner with petroleum oil, or well besprinkled with brandy, and then dried. The bottom of the globe ought to be covered with a little gunpowder half pulverised and half grained; which, when set on fire, by means of a match applied to the end of the chamber, will set fire to the lower part of the reed. But care must have been taken to fill the chamber with a composition similar to that in the reeds, or with another slow composition made of eight ounces of gunpowder, four ounces of saltpetre, two ounces of sulphur, and one ounce of charcoal: the whole must be well pounded and mixed. Instead of reeds, the globe may be charged with running rockets, or paper petards, and a quantity of fiery stars or sparks mixed with pulverised gunpowder, placed without any order above these petards, which must be choked at unequal heights, that they may perform their effect at different times.

These globes may be constructed in various other ways, which it would be tedious here to enumerate. We shall only observe that, when

loaded, they must be well covered at the top; they must be wrapped up in a piece of cloth dipped in glue, and a piece of woollen cloth must be tied round them, so as to cover the hole which contains the match.

9. *Jets of fire.*—Jets of fire are a kind of fixed rockets, the effect of which is to throw up into the air jets of fire, similar to jets of water. They serve also to represent cascades: for if a series of such rockets be placed horizontally on the same line, it may be easily seen that the fire they emit will resemble a sheet of water. When arranged in a circular form, like the radii of a circle, they form what is called a fixed sun. To form jets of this kind, the cartridge for brilliant fires must, in thickness, be equal to a fourth part of the diameter, and, for Chinese fire, only to a sixth part.

The cartridge is loaded on a nipple, having a point equal in length to the same diameter, and in thickness to a fourth part of it; but, as it generally happens that the mouth of the jet becomes larger than is necessary for the effect of the fire, you must begin to charge the cartridge, as the Chinese do, by filling it to a height equal to a fourth part of the diameter with clay, which must be rammed down as if it were gunpowder. By these means the jet will ascend much higher. When the charge is completed with the composition you have made choice of, the cartridge must be close with a tompon of wood, above which it must be choked. The train or match must be of the same composition as that employed for loading; otherwise the dilatation of the air contained in the hole made by the piercer would cause the jet to burst. Clayed rockets may be pierced with two holes near the neck, in order to have three jets in the same plane.

If a kind of top, pierced with a number of holes, be added to them, they will imitate a bubbling fountain. Jets intended for representing sheets of fire ought not to be choked. They must be placed in a horizontal position, or inclined a little downwards. It appears to us that they might be choked so as to form a kind of slit, and be pierced in the same manner; which would contribute to extend the sheet of fire still farther. A kind of long narrow mouth might even be provided for this particular purpose.

*Principal compositions for jets of fire.*

1st. Jets of five lines, or less, of interior diameter.

*Chinese fire.*—Saltpetre one pound, pulverised gunpowder one pound, sulphur eight ounces, charcoal two ounces.

*White fire.*—Saltpetre one pound, pulverised gunpowder eight ounces, sulphur three ounces, charcoal two ounces, iron sand of the first order eight ounces.

2d. Jets of from ten to twelve lines in diameter.

*Brilliant fire.*—Pulverised gunpowder one pound, iron filings of a mean size five ounces.

*White fire.*—Saltpetre one pound, pulverised gunpowder one pound, sulphur eight ounces, charcoal two ounces.

*Chinese fire.*—Saltpetre one pound four ounces, sulphur five ounces, sand of the third order twelve ounces.

3d. Jets of fifteen or eighteen lines in diameter  
*Chinese fire.*—Saltpetre one pound four ounces, sulphur seven ounces, charcoal five ounces, of the six different kinds of sand mixed twelve ounces. Père d'Incarville, in his memoirs on this subject, gives various other proportions for the composition of these jets; but we must confine ourselves to what has been here said, and refer the reader to the author's memoirs, which will be found in the *Manuel de l'Artificier*.

The saltpetre, pulverised gunpowder, and charcoal, are three times sifted through a hair sieve. The iron sand is besprinkled with sulphur, after being moistened with a little brandy, that the sulphur may adhere to it; and they are then mixed together: the sulphured sand is then spread over the first mixture, and the whole is mixed with a ladle only; for if a sieve were employed, it would separate the sand from the other materials. When sand larger than that of the second order is used, the composition is moistened with brandy, so that it forms itself into balls, and the jets are then loaded: if there were too much moisture, the sand would not perform its effect.

10. *Of fires of different colors.*—It is much to be wished that, for the sake of variety, different colors could be given to these fire-works at pleasure; but, though we are acquainted with several materials which communicate to flame various colors, it has hitherto been possible to introduce only a very few colors into that of inflamed gunpowder.

To make white fire, the gunpowder must be mixed with iron or rather steel filings.

To make red fire, iron sand of the first order must be employed in the same manner.

As copper filings, when thrown into a flame, render it green, it might be concluded that, if mixed with gunpowder, it would produce a green flame; but this experiment does not succeed. It is supposed that the flame is too ardent, and consumes the inflammable part of the copper too soon. But it is probable that a sufficient number of trials have not yet been made; for is it not possible to lessen the force of gunpowder in a considerable degree, by increasing the dose of the charcoal?

However the following are a few of those materials which, in books on pyrotechny, are said to possess the property of communicating various colors to fire-works.

Camphor mixed with the composition makes the flame to appear of a pale white color.

Raspings of ivory give a clear flame of a silver color, inclining a little to that of lead; or rather a white dazzling flame.

Greek pitch produces a reddish flame, of a bronze color.

Black pitch, a dusky flame, like a thick smoke, which obscures the atmosphere.

Sulphur, mixed in a moderate quantity, makes the flame appear bluish.

Sal ammoniac and verdigris give a greenish flame.

Raspings of yellow amber communicate to the flame a lemon color.

Crude antimony gives a russet color.

Borax ought to produce a blue flame; for spirit of wine, in which sedative salt, one of the component parts of borax, is dissolved by the means of heat, burns with a beautiful green flame.

Much, however, still remains to be done in regard to this subject; but it would add to the beauty of artificial fire-works, if they could be varied by giving them different colors: this would be creating for the eyes a new pleasure.

11. *Composition of a paste proper for representing animals, and other devices in fire.*—It is to the Chinese also that we are indebted for this method of representing figures with fire. For this purpose, take sulphur reduced to an impalpable powder, and, having formed it into a paste with starch, cover with it the figure you are desirous of representing on fire: it is here to be observed that the figure must first be coated over with clay, to prevent it from being burnt. When the figure has been covered with this paste, besprinkle it while still moist with pulverised gunpowder; and, when the whole is perfectly dry, arrange some small matches on the principal parts of it, that the fire may be speedily communicated to it on all sides.

The same paste may be employed on figures of clay, to form devices and various designs. Thus, for example, festoons, garlands, and other ornaments, the flowers of which might be imitated by fire of different colors, could be formed on the frieze of a piece of architecture, covered with plaster. The Chinese imitate grapes exceedingly well, by mixing pounded sulphur with the pulp of the jube instead of flour paste.

12. *Of suns both fixed and moveable.*—None of the pyrotechnic inventions can be employed with so much success, in artificial fire-works, as suns; of which there are two kinds, fixed and revolving: the method of constructing both is very simple.

For fixed suns, cause to be constructed a round piece of wood, into the circumference of which can be screwed twelve or fifteen pieces in the form of radii; and to these radii attach jets of fire, the composition of which has been already described, so that they may appear as radii tending to the same centre, the mouth of the jet being towards the circumference. Apply a match in such a manner that the fire communicated at the centre may be conveyed, at the same time, to the mouth of each of the jets; by which means, each throwing out its fire, there will be produced the appearance of a radiating sun. We here suppose that the wheel is placed in a position perpendicular to the horizon. These rockets or jets may be so arranged as to cross each other in an angular manner; in which case, instead of a sun, you will have a star, or a sort of cross resembling that of Malta. Some of these suns are made also with several rows of jets: these are called glories.

Revolving suns may be constructed in this manner:—Provide a wooden wheel, of any size at pleasure, and brought into perfect equilibrium around its centre, in order that the least effort may make it turn round. Attach to the circumference of it fire-jets placed in the direction of the circumference; they must not be choked at the bottom, and ought to be arranged in such a

Vol. XVIII.

manner that the mouth of the one shall be near the bottom of the other, so that when the fire of the one is ended it may immediately proceed to another. It may easily be perceived that, when fire is applied to one of these jets, the recoil of the rocket will make the wheel turn round, unless it be too large and ponderous: for this reason, when these suns are of a considerable size, that is, when they consist for example of twenty rockets, fire must be communicated at the same time to the first, the sixth, the eleventh, and the sixteenth; from which it will proceed to the second, the seventh, the twelfth, the seventeenth, and so on. These four rockets will make the wheel turn round with rapidity.

If two similar suns be placed one behind the other, and made to turn in a contrary direction, they will produce a very pretty effect of cross-fire. Three or four suns, with horizontal axes passed through them, might be implanted in a vertical axis, moveable in the middle of a table. These suns, revolving around the table, will seem to pursue each other. It may be easily perceived that, to make them turn around the table, they must be fixed on their axes, and these axes, at the place where they rest on the table, ought to be furnished with a very moveable roller.

13. *To make crackers.*—Cut some stout cartridge paper into pieces three inches and a half broad, and one foot long; one edge of each of these pieces fold down lengthwise about three-quarters of an inch broad; then fold the double edge down a quarter of an inch, and turn the single edge back half over the double fold; open it, and lay all along the channel, which is formed by the foldings of the paper, some meal powder; then fold it over and over till all the paper is doubled up, rubbing it down every turn; this being done, bend it backwards and forwards, two inches and a half, or thereabouts, at a time, as often as the paper will allow; hold all these folds flat and close, and, with a small pinching cord, give one turn round the middle of the cracker, and pinch it close; bind it with pack-thread, as tight as you can; then, in the place where it was pinched, prime one end and cap it with touch-paper. When these crackers are fired they will give a report at every turn of the paper; if you would have a great number of bounces, you must cut the paper longer, or join them after they are made; but, if they are made very long before they are pinched, you must have a piece of wood with a groove in it, deep enough to let in half the cracker; this will hold it straight while it is pinching.

14. *To make squibs.*—First make the cases, of about six inches in length, by rolling slips of stout cartridge paper three times round a roller, and pasting the last fold; tying it near the bottom as tight as possible, and making it air-tight at the end by sealing-wax. Then take of gunpowder half a pound, charcoal one ounce, brimstone one ounce, and steel filings half an ounce (or in like proportion); grind them with a muller, or pound them in a mortar. Your cases being dry and ready, first put a thimble full of your powder, and ram it hard down with a ruler; then fill the case to the top with the aforesaid mixture, ramming it hard down in the course of filling two or



three times; when this is done point it with touch-paper, which should be pasted on that part which touches the case, otherwise it is liable to drop off.

•• The apparatus chiefly used in making fireworks consists of solid wooden cylinders, called formers, for rolling the cases on; similar cylinders, either of wood or metal, for ramming down the composition; moulds for holding the cases while filling; a machine for contracting the cavity of the cases; another for grinding the materials; and a particular apparatus for boring some cases after they are filled.

#### IMITATIVE FIREWORKS.

Take a paper that is blacked on both sides, or, instead of black, the paper may be colored on each side with a deep blue, which will be still better for such as are to be seen through transparent papers. It must be of a proper size for the figure you intend to exhibit. In this paper cut out with a penknife several spaces, and with a piercer make a great number of holes, rather long than round, and at no regular distance from each other.

To represent revolving pyramids and globes, the paper must be cut through with a penknife, and the space cut out between each spiral should be three or four times as wide as the spirals themselves. You must observe to cut them so that the pyramid or globe may appear to turn on its axis. The columns that are represented in pieces of architecture, or in jets of fire, must be cut in the same manner, if they are to be represented as turning on their axes. In like manner may be exhibited a great variety of ornaments, cyphers, and medallions, which, when properly colored, cannot fail of producing a most pleasing effect. There should not be a very great diversity of colors, as that would not produce the most agreeable appearance.

When these pieces are drawn on a large scale, the architecture or ornaments may be shaded: and, to represent different shades, pieces of colored paper must be pasted over each other, which will produce an effect that would not be expected from transparent paintings. Five or six pieces of paper pasted over each other will be sufficient to represent the strongest shades.

To give these pieces the different motions they require, you must first consider the nature of each piece; if, for example, you have cut out the figure of the sun, or of a star, you must construct a wire wheel of the same diameter with those pieces; over this wheel you paste a very thin paper, on which is drawn, with black ink, the spiral figure. The wheel thus prepared is to be placed behind the sun or star, in such a manner that its axis may be exactly opposite the centre of either of those figures. This wheel may be turned by any method you think proper.

Now, the wheel being placed directly behind the sun, for example, and very near to it, is to be turned regularly round, and strongly illuminated by candles placed behind it. The lines that form the spiral will then appear, through the spaces cut out from the sun, to proceed from its centre to its circumference, and will resemble

sparks of fire that incessantly succeed each other. The same effect will be produced by the star, or by any other figure where the fire is not to appear as proceeding from the circumference of the centre.

These two pieces, as well as those that follow, may be of any size, provided you observe the proportion between the parts of the figure and the spiral, which must be wider in larger figures than in small. If the sun, for example, have from six to twelve inches diameter, the width of the strokes that form the spiral need not be more than one-twentieth part of an inch, and the spaces between them, that form the transparent parts, about two-tenths of an inch. If the sun be two feet diameter, the strokes should be one-eighth of an inch, and the space between one-quarter of an inch; and, if the figure be six feet diameter, the strokes should be one-quarter of an inch and the spaces five twelfths of an inch. These pieces have a pleasing effect when represented of a small size, but the deception is more striking when they are of large dimensions.

It will be proper to place those pieces, when of a small size, in a box quite closed on every side, that none of the light may be diffused in the chamber: for which purpose it will be convenient to have a tin door behind the box, to which the candlesticks may be soldered, and the candles more easily lighted.

The several figures cut out should be placed in frames, that they may be put alternately in a groove in the fore-part of the box; or there may be two grooves, that the second piece may be put in before the first is taken out.

The wheel must be carefully concealed from the eye of the spectator.

Where there is an opportunity of representing these artificial fires by a hole in the partition, they will doubtless have a much more striking effect, as the spectator cannot then conjecture by what means they are produced.

It is easy to conceive that, by extending this method, wheels may be constructed with three or four spirals, to which may be given different directions. It is manifest, also, that on the same principle a great variety of transparent figures may be contrived, and which may be all placed before the same spiral lines.

*To represent cascades of fire.*—In cutting out cascades, you must take care to preserve a natural inequality in the parts cut out; for if to save time you should make all the holes with the same pointed tool, the uniformity of the parts will not fail to produce a disagreeable effect. As these cascades are very pleasing when well executed, so they are highly disgusting when imperfect. These are the most difficult pieces to cut out.

To produce the apparent motion of these cascades, instead of drawing a spiral you must have a slip of strong paper, of such length as you judge convenient. In this paper there must be a great number of holes near each other, and made with pointed tools of different dimensions.

At each end of the paper, a part, of the same size with the cascade, must be left uncut; and towards those parts the holes must be made a greater distance from each other.

When the cascade that is cut out is placed be-

fore the scroll of paper just mentioned, and it is entirely wound upon the roller, the part of the paper that is then between being quite opaque, no part of the cascade will be visible; but, as the winch is turned gently and regularly round, the transparent part of the paper will give to the cascade the appearance of fire that descends in the same direction; and the illusion will be so strong that the spectators will think they see a cascade of fire, especially if the figure be judiciously cut out.

## PART II. OF ROCKETS.

### SECT. I.—CONSTRUCTION OF THE CASES.

Rockets may be regarded as the grand basis of all fire-works, which are little more than modifications of their form, and of the materials of which they usually consist. A rocket is a cartridge or case made of stiff paper, which being filled in part with gunpowder, saltpetre, and charcoal, rises of itself into the air, when fire is applied to it.

There are three sorts of rockets: small ones the calibre of which does not exceed a pound bullet; that is to say, the orifice of them is equal to the diameter of a leaden bullet which weighs only a pound; for the calibres or orifices of the moulds or the models used in making rockets are measured by the diameters of leaden bullets. Middle sized rockets, equal to the size of a ball of from one to three pounds. And large rockets, equal to a ball of from three to 100 pounds.

To give the cartridges the same length and thickness, in order that any number of rockets may be prepared of the same size and force, they are put into a hollow cylinder of strong wood, called a mould. This mould is sometimes of metal; but at any rate it ought to be made of some very hard wood. This mould must not be confounded with another piece of wood, called the former or roller, around which is rolled the thick paper employed to make the cartridge. If the calibre of the mould be divided into eight equal parts, the diameter of the roller must be equal to five of these parts. The vacuity between the roller and the interior surface of the mould, that is to say three-eighths of the calibre of the mould, will be exactly filled by the cartridge.

As rockets are made of different sizes, moulds of different lengths and diameters must be provided. The calibre of a cannon is nothing else than the diameter of its mouth; and we here apply the same term to the diameter of the aperture of the mould. The size of the mould is measured by its calibre; but the length of the moulds for different rockets does not always bear the same proportion to the calibre, the length being diminished as the calibre is increased. The length of the mould for small rockets ought to be six times the calibre, but for rockets of the mean and larger size it will be sufficient if the length of the mould be five times or four times the calibre of the moulds. We shall give two tables, one of which contains the calibres of moulds below a pound bullet; and the other

the calibres from a pound to 100 pounds bullet.

For making the cartridges, large stiff paper is employed. This paper is wrapped round the roller, and then cemented by means of common paste. The thickness of the paper, when rolled up in this manner, ought to be about one-eighth and a half of the calibre of the mould, according to the proportion given to the diameter of the roller. But, if the diameter of the roller be made equal to three-fourths the calibre of the mould, the thickness of the cartridge must be a twelfth and a half of that calibre. When the cartridge is formed, the roller is drawn out, by turning it round, until it is distant from the edge of the cartridge the length of its diameter. A piece of cord is then made to pass twice round the cartridge at the extremity of the roller. And into the vacuity left in the cartridge another roller is introduced, so as to leave some space between the two. One end of the pack-thread must be fastened to something fixed, and the other to a stick conveyed between the legs, and placed in such a manner as to be behind the person who chokes the cartridge. The cord is then to be stretched by retiring backwards, and the cartridge must be pinched until there remains only an aperture capable of admitting the piercer. The cord employed for pinching it is then removed, and its place is supplied by a piece of pack-thread, which must be drawn very tight, passing it several times round the cartridge, after which it is secured by means of running knots made one above the other.

Besides the roller, a rod is used, which being employed to load the cartridge, must be somewhat smaller than the roller, in order that it may be easily introduced into the cartridge. The rod is pierced lengthwise, to a sufficient depth to receive the piercer, which must enter into the mould, and unite with it exactly at its lower part. The piercer, which decreases in size, is introduced into the cartridge through the part where it has been choked, and serves to preserve a cavity within it. Its length, besides the nipple or button, must be equal to about two-thirds that of the mould. Lastly, if the thickness of the base be a fourth part of the calibre of the mould, the point must be made equal to a sixth of the calibre. It is evident there must be at least three rods, pierced in proportion to the diminution of the piercer, in order that the powder which is rammed in by means of a mallet, may be uniformly packed throughout the whole length of the rocket. It may be easily perceived, also, that these rods ought to be made of some very hard wood, to resist the strokes of the mallet.

In loading rockets it is more convenient not to employ a piercer. When loaded on a nipple, without a piercer, by means of one massy rod, they are pierced with a bit and a piercer fitted into the end of a bit-brace. Care however must be taken to make this hole suited to the proportion assigned for the diminution of the piercer. That is to say, the extremity of the hole, at the choked part of the cartridge, ought to be at about a fourth of the calibre of the mould; and the extremity of the hole which is in the inside for

about two-thirds of the length of the rocket ought to be a sixth of the calibre. This hole must pass directly through the middle of the rocket. In short, experience and ingenuity will suggest what is most convenient, and in what manner the method of loading rockets, which we shall here explain, may be varied.

After the cartridge is placed in the mould, pour gradually into it the prepared composition; taking care to pour only two spoonfuls at a time, and to ram it immediately down with the rod, striking it in a perpendicular direction with a mallet of a proper size, and giving an equal number of strokes, for example, three or four each time that a new quantity of the composition is poured in. When the cartridge is about half filled, separate with a bodkin the half of the folds of the paper which remains, and, having turned them back on the composition, press them down with the rod and a few strokes of the mallet, in order to compress the paper on the composition. Then pierce three or four holes in the folded paper, by means of a piercer, which must be made to penetrate to the composition of the rocket. These holes serve to form a communication between the body of the rocket and the vacuity at the extremity of the cartridge, or that part which has been left empty.

In small rockets this vacuity is filled with granulated powder, which serves to let them off: they are then covered with paper, and pinched in the same manner as at the other extremity. But in other rockets, the pot containing stars, serpents, and running rockets, is adapted to it, as will be shown hereafter. It may be sufficient however to make, with a bit or piercer, only one hole, which must be neither too large nor too small, such as a fourth part of the diameter of the rocket, to set fire to the powder, taking care that this hole be as straight as possible, and exactly in the middle of the composition. A little of the composition of the rocket must be put into these holes, that the fire may not fail to be communicated to it.

It now remains to fix the rocket to its rod, which is done in the following manner:—When the rocket has been constructed as above described, make fast to it a rod of light wood, such as fir or willow, broad and flat at the end next the rocket, and decreasing towards the other. It must be as straight and free from knots as possible, and ought to be dressed, if necessary, with a plane. Its length and weight must be proportioned to the rocket; that is to say, it ought to be six, seven, or eight feet long, so as to remain in equilibrium with it, when suspended on the finger, within an inch, or an inch and a half of the neck. Before it is fired, place it with the neck downwards, and let it rest on two nails, in a direction perpendicular to the horizon. To make it ascend straighter and to a greater height, adapt to its summit a pointed cap or top, made of common paper, which will serve to facilitate its passage through the air.

These rockets, in general, are made in a more complex manner, several other things being added to them to render them more agreeable, such for example as a petard, which is a box of

tin-plate, filled with fine gunpowder, placed on the summit. The petard is deposited on the composition, at the end where it has been filled; and the remaining paper of the cartridge is folded down over it to keep it firm. The petard produces its effect when the rocket is in the air and the composition is consumed.

Stars, golden rain, serpents, saucissons, and several other amusing things, may also, as we have seen, be added to them. This is done by adjusting to the head of the rocket, an empty pot or cartridge, much larger than the rocket, in order that it may contain serpents, stars, and various other appendages, to render it more beautiful.

Rockets may be made to rise into the air without rods. For this purpose four wings must be attached to them in the form of a cross, and similar to those seen on arrows or darts. In length, these wings must be equal to two-thirds that of the rocket; their breadth towards the bottom should be half their length, and their thickness ought to be equal to that of a card. But this method of making rockets ascend is less certain, and more inconvenient, than that where a rod is used; and for this reason it is rarely employed.

We shall now show the method of finding the diameters or calibre of rockets, according to their weight; but we must first observe that a pound rocket is that just capable of admitting a leaden bullet of a pound weight, and so of the rest. The calibre for the different sizes may be found by the two following tables, one of which is calculated for rockets of a pound weight and below; and the other for those from a pound weight to fifty pounds.

I. TABLE of the calibre of moulds of a pound weight and below

Ounces.	Lines.	Drachms.	Lines.
16	19½	14	7½
12	17	12	7
8	15	10	6½
7	14½	8	6½
6	14¼	6	5¾
5	13	4	4½
4	12½	2	3½
3	11½		
2	9½		
1	6½		

The use of this table will be understood merely by inspection; for it is evident that a rocket of twelve ounces ought to be seventeen lines in diameter; one of eight ounces, fifteen lines; one of ten drachms, six lines and one-third; and so of the rest. On the other hand, if the diameter of the rocket be given, it will be easy to find the weight of the ball corresponding to that calibre. For example, if the diameter be thirteen lines, it will be immediately seen, by looking for that number in the column of lines, that it corresponds to a ball of five ounces.

II. TABLE of the calibre of moulds from one to fifty pounds ball.

Pounds.	Calibre.	Pounds.	Calibre.	Pounds.	Calibre.	Pounds.	Calibre.
1	100	14	241	27	300	40	341
2	126	15	247	28	304	41	344
3	144	16	252	29	307	42	347
4	158	17	257	30	310	43	350
5	171	18	262	31	314	44	353
6	181	19	267	32	317	45	355
7	191	20	271	33	320	46	358
8	200	21	275	34	323	47	361
9	208	22	280	35	326	48	363
10	215	23	284	36	330	49	366
11	222	24	288	37	333	50	368
12	228	25	292	38	336		
13	235	26	296	39	339		

The use of the second table is as follows:—If the weight of the ball be given, which we shall suppose to be twenty-four pounds, seek for that number in the column of pounds, and opposite to it, in the column of calibres, will be found the number 288. Then say, as 100 is to nineteen and a half so is 288 to a fourth term, which will be the number of lines of the calibre required; or multiply the number found, that is 288, by nineteen and a half, and from the product, 56·16, cut off the last two figures: the required calibre therefore will be 56·16 lines, or four inches eight lines.

On the other hand, the calibre being given in lines, the weight of the ball may be found with equal ease: if the calibre, for example, be twenty-eight lines, say as nineteen and a half is to twenty-eight so is 100 to a fourth term, which will be 143·5 or nearly 144. But in the above table, opposite to 144 in the second column, will be found the number three in the first; which shows that a rocket, the diameter or calibre of which is twenty-eight lines, is a rocket of a three pounds ball.

SECT. II.—COMPOSITION OF THE POWDER FOR ROCKETS, AND THE MODE OF FILLING THEM.

The composition of the powder for rockets must be different, according to the different sizes; as that proper for small rockets would be too strong for large ones. This is a fact respecting which almost all the makers of fire-works are agreed. The quantities of the ingredients which experience has shown to be the best are as follow:—

*For rockets capable of containing one or two ounces of composition.*—To one pound of gunpowder add two ounces of soft charcoal; or to one pound of gunpowder a pound of the coarse powder used for cannon; or to nine ounces of gunpowder two ounces of charcoal; or to a pound of gunpowder an ounce and a half of saltpetre, and as much charcoal.

*For rockets of two or three ounces.*—To four ounces of gunpowder add an ounce of charcoal; or to nine ounces of gunpowder add two ounces of saltpetre.

*For a rocket of four ounces.*—To four pounds of gunpowder add a pound of saltpetre and four ounces of charcoal: you may add also, if you

choose, half an ounce of sulphur; or to one pound two ounces and a half of gunpowder add four ounces of saltpetre and two ounces of charcoal; or to a pound of powder add four ounces of saltpetre and one ounce of charcoal; or to seventeen ounces of gunpowder add four ounces of saltpetre and the same quantity of charcoal; or to three ounces and a half of gunpowder add ten ounces of saltpetre and three ounces and a half of charcoal. But the composition will be strongest if to ten ounces of gunpowder you add three ounces and a half of saltpetre and three ounces of charcoal.

*For a rocket of five or six ounces.*—To two pounds five ounces of gunpowder add half a pound of saltpetre, two ounces of sulphur, six ounces of charcoal, and two ounces of iron filings.

*For rockets of seven or eight ounces.*—To seventeen ounces of gunpowder add four ounces of saltpetre and three ounces of sulphur.

*For rockets of from eight to ten ounces.*—To two pounds and five ounces of gunpowder add half a pound of saltpetre, two ounces of sulphur, seven ounces of charcoal, and three ounces of iron filings.

*For rockets of from ten to twelve ounces.*—To seventeen ounces of gunpowder add four ounces of saltpetre, three ounces and a half of sulphur, and one ounce of charcoal.

*For rockets of from fourteen to fifteen ounces.*—To two pounds four ounces of gunpowder add nine ounces of saltpetre, three ounces of sulphur, five ounces of charcoal, and three ounces of iron filings.

*For rockets of one pound.*—To one pound of gunpowder add one ounce of sulphur and three ounces of charcoal.

*For a rocket of two pounds.*—To one pound four ounces of gunpowder add two ounces of saltpetre, one ounce of sulphur, three ounces of charcoal, and two ounces of iron filings.

*For a rocket of three pounds.*—To thirty ounces of saltpetre add seven ounces and a half of sulphur and eleven ounces of charcoal.

*For rockets of four, five, six, or seven pounds.*—To thirty-one pounds of saltpetre add four pounds and a half of sulphur and ten pounds of charcoal.

*For rockets of eight, nine, or ten pounds.*—

To eight pounds of saltpetre add one pound four ounces of sulphur and two pounds twelve ounces of charcoal.

We shall here observe, that these ingredients must be each pounded separately and sifted; they are then to be weighed and mixed together, for the purpose of loading the cartridges, which ought to be kept ready in the moulds. The cartridges must be made of strong paper, doubled, and cemented by means of strong paste, made of fine flour and very pure water.

*Of Matches.*—Before we proceed farther it will be proper to describe the composition of the matches necessary for letting the rockets off. Take linen, hemp, or cotton thread, and double it eight or ten times, if intended for large rockets; or only four or five times, if to be employed for stars. When the match has been thus made as large as necessary, dip it in pure water, and press it between your hands, to free it from the moisture. Mix some gunpowder with a little water, to reduce it to a sort of paste, and immerse the match in it, turning and twisting it till it has imbibed a sufficient quantity of the powder; then sprinkle over it a little dry powder, or strew some pulverised dry powder upon a smooth board, and roll the match over it. By these means you will have an excellent match; which if dried in the sun, or on a rope in the shade, will be fit for use.

### SECT. III.—FORMATION OF ROCKETS.

The upper part of rockets is generally furnished with some composition, which takes fire when it has reached to its greatest height, emits a considerable blaze, or produces a loud report and whizzing noise. Of this kind are saucissons, maroons, stars, showers of fire, &c To make room for an artifice of this kind, the rocket is crowned with a part of greater diameter called a pot. The following is the method of making this pot, and connecting it with the rocket:—

The mould for forming the pot, though of one piece, must consist of two cylindric parts of different diameters. That on which the pot is rolled up must be three diameters of the rocket in length, and its diameter must be three-fourths that of the rocket; the length of the other ought to be equal to two of these diameters, and its diameter to seven-fifths that of the rocket. Having rolled the thick paper, intended for making the pot, twice round the cylinder, a portion of it must be pinched in that part of the cylinder which has the least diameter: this part must be pared in such a manner as to leave only what is necessary for making the pot fast to the top of the rocket, and the ligature must be covered with paper.

To charge such a pot, attached to a rocket. Having pierced three or four holes in the double paper which covers the vacuity of the rocket, pour over it a small quantity of the composition with which the rocket is filled, and by shaking it make a part enter these holes; then arrange, in the pot, the composition with which it is to be charged, taking care not to introduce into it a quantity heavier than the body of the rocket. The whole must be secured by means of a few

small balls of paper, and the pot covered with paper cemented to its edges: let a pointed summit be added to it, and the rocket is fit for use.

We shall now give an account of the different artifices with which such rockets are loaded.

1. *Of serpents.*—Serpents are small flying rockets without rods, which, instead of rising in a perpendicular direction, mount obliquely, and fall back in a zig-zag form without ascending to a great height. The composition of them is nearly the same as that of rockets; and therefore nothing more is necessary than to determine the proportion and construction of the cartridge, which is as follows:—The length of the cartridge may be about four inches; it must be rolled round a stick somewhat larger than the barrel of a goose-quill, and, after being choked at one of its ends, fill it with the composition a little beyond its middle, and then pinch it so as to leave a small aperture. The remainder must be filled with grained powder, which will make a report when it bursts. Lastly, choke the cartridge entirely towards the extremity; and at the other extremity place a grain of moist powder, to which, if fire be applied, it will be communicated to the composition, and cause the whole to rise in the air. The serpent, as it falls, will make several turns in a zig-zag direction, till the fire is communicated to the grained powder; on which it will burst with a loud report before it falls to the ground.

If the serpent be not choked towards the middle, instead of moving in a zig-zag direction, it will ascend and descend with an undulating motion, and then burst as before. The cartridges of serpents are generally made with playing cards. These cards are rolled round a rod of iron or hard wood, a little larger, as already said, than the barrel of a goose-quill. To confine the card, a piece of strong paper is cemented over it. The length of the mould must be proportioned to that of the cards employed, and the piercer of the nipple must be three or four lines in length. These serpents are loaded with bruised powder, mixed only with a very small quantity of charcoal. To introduce the composition into the cartridge, a quill, cut into the form of a spoon, may be employed; it must be rammed down by means of a small rod, to which a few strokes are given with a small mallet.

When the serpent is half loaded, instead of pinching it in that part, you may introduce into it a vetch seed, and place granulated powder above it to fill up the remainder. Above this powder place a small pellet of chewed paper, and then choke the other end of the cartridge. If you are desirous of making larger serpents, cement two playing cards together; and, that they may be managed with more ease, moisten them a little with water. The match consists of a paste made of bruised powder, and a small quantity of water.

2. *Maroons.*—Maroons are small cubical boxes, filled with a composition proper for making them burst, and may be constructed with great ease.

Cut a piece of pasteboard, according to the method taught in geometry to form the cube; join these squares at the edges, leaving only one

to be cemented, and fill the cavity of the cube with grained powder; then cement strong paper in various directions over this body; and wrap round it two rows of pack-thread, dipped in strong glue; then make a hole in one of the corners, and introduce into it a match. If you are desirous to have luminous marroons, that is to say, marroons which, before they burst in the air, emit a brilliant light, cover them with a paste the composition of which will be given hereafter for stars; and roll them in pulverised gunpowder to serve as a match or communication.

3. *Saucissons*.—Marroons and saucissons differ from each other only in their form. The cartridges of the latter are round, and must be only four times their exterior diameter in length. They are choked at one end in the same manner as a rocket; and a pellet of paper is driven into the aperture which has been left, in order to fill it up. They are then charged with grained powder, above which is placed a ball of paper gently pressed down, to prevent the powder from being bruised; the second end of the saucisson being afterwards choked, the edges are pared on both sides, and the whole is covered with several turns of pack-thread, dipped in strong glue, and then left to dry. When you are desirous of charging them, pierce a hole in one of the ends, and apply a match, in the same manner as marroons.

4. *Stars*.—Stars are small globes of a composition which emits a brilliant light, which may be compared to the light of the stars in the heavens. These balls are not larger than a nutmeg or musket bullet, and when put into the rockets must be wrapped up in tow, prepared for that purpose. The composition of these stars is as follows:—To a pound of fine gunpowder well pulverised add four pounds of saltpetre, and two pounds of sulphur. When these ingredients are thoroughly incorporated, take about the size of a nutmeg of this mixture, and having wrapt it up in a piece of linen rag, or of paper, form it into a ball; then tie it closely round with a packthread, and pierce a hole through the middle of it, sufficiently large to receive a piece of prepared tow, which will serve as a match. This star, when lighted, will exhibit a most beautiful appearance; besides the fire, as it issues from the two ends of the hole in the middle, will extend to a greater distance, and make it appear much larger.

If you are desirous to employ a moist composition in the form of a paste, instead of a dry one, it will not be necessary to wrap up the star in any thing but prepared tow; because, when made of such paste, it can retain its spherical figure. There will be no need also of piercing a hole in it, to receive the match; because, when newly made, and consequently moist, it may be rolled in pulverised gunpowder, which will adhere to it. This powder, when kindled, will serve as a match, and inflame the composition of the star, which in falling will form itself into tears.

*Another method of making rockets with stars*.—Mix three ounces of saltpetre, with one ounce of sulphur, and two drachms of pulverised gunpowder; or mix four ounces of sulphur with the same quantity of saltpetre and eight ounces

of pulverised gunpowder. When these materials have been well sifted, besprinkle them with brandy, in which a little gum has been dissolved, and then make up the star in the following manner:—Take a rocket mould, eight or nine lines in diameter, and introduce into it a nipple, the piercer of which is of a uniform size throughout, and equal in length to the height of the mould. Put into this mould a cartridge, and by means of a pierced rod load it with one of the preceding compositions; when loaded, take it from the mould, without removing the nipple, the piercer of which passes through the composition, and then cut the cartridge quite round into pieces of the thickness of three or four lines. The cartridge being thus cut, draw out the piercer gently, and the pieces, which resemble the men employed for playing at drafts, pierced through the middle, will be stars, which must be filed on a match thread, which, if you choose, may be covered with tow.

To give more brilliancy to stars of this kind, a cartridge thicker than the above dimensions, and thinner than that of a flying rocket of the same size, may be employed; but, before it is cut into pieces, five or six holes must be pierced in the circumference of each piece to be cut. When the cartridge is cut, and the pieces have been filled, cement over the composition small bits of card, each having a hole in the middle, so that these holes may correspond to the place where the composition is pierced.

*Remarks*.—1. There are several other methods of making stars, which it would be too tedious to describe. We shall therefore only show how to make étoiles à pet, or stars which give a report as loud as that of a pistol or musket. Make small saucissons, as taught in the third section; only it will not be necessary to cover them with pack-thread: it will be sufficient if they are pierced at one end, in order that you may tie to it a star constructed according to the first method, the composition of which is dry; for, if the composition be in the form of a paste, there will be no need to tie it. Nothing will be necessary in that case but to leave a little more of the paper hollow at the end of the saucisson which has been pierced, for the purpose of introducing the composition; and to place in the vacancy, towards the neck of the saucisson, some grained powder, which will communicate fire to the saucisson when the composition is consumed.

2. As there are some stars which in the end become petards, others may be made which shall conclude with becoming serpents. But this may be so easily conceived and carried into execution that it would be losing time to enlarge further on the subject. We shall only observe that these stars are not in use, because it is difficult for a rocket to carry them to a considerable height in the air: they diminish the effect of the rocket or saucisson, and much time is required to make them.

SECT. IV.—OF COURANTINS OR ROCKETS WHICH FLY ALONG A ROPE.

A common rocket, which however ought not to be very large, may be made to run along an extended rope. For this purpose affix to the

rocket an empty cartridge, and introduce into it the rope which is to carry it; placing the head of the rocket towards that side on which you intend it to move: if you then set fire to the rocket, adjusted in this manner, it will run along the rope without stopping, till the matter it contains is entirely exhausted. If you are desirous that the rocket should move in a retrograde direction; first fill one-half of it with the composition, and cover it with a small round piece of wood, to serve as a partition between it and that put into the other half; then make a hole below this partition, so as to correspond with a small canal filled with bruised powder, and terminating at the other end of the rocket: by these means the fire, when it ceases in the first half of the rocket, will be communicated through the hole into the small canal, which will convey it to the other end; and, this end being then kindled, the rocket will move backwards, and return to the place from which it set out.

Two rockets of equal size, bound together by means of a piece of strong pack-thread, and disposed in such a manner that the head of the one shall be opposite to the neck of the other, that when the fire has consumed the composition in the one it may be communicated to that in the other, and oblige both of them to move in a retrograde direction, may also be adjusted to the rope by means of a piece of hollow reed. But, to prevent the fire of the former from being communicated to the second too soon, they ought to be covered with oil-cloth, or to be wrapped up in paper.

*Remark.*—Rockets of this kind are generally employed for setting fire to various other pieces when large fire-works are exhibited; and to render them more agreeable, they are made in the form of different animals, such as serpents, dragons, &c.; on which account they are called flying dragons. These dragons are very amusing, especially when filled with various compositions, such as golden rain, long hair, &c. They might be made to discharge serpents from their mouths, which would produce a very pleasing effect, and give them a greater resemblance to a dragon.

*Rockets which fly along a rope, and turn round at the same time.*—Nothing is easier than to give to a rocket of this kind a rotatory motion around the rope along which it advances; it will be sufficient for this purpose to tie it to another rocket, placed in a transversal direction. But the aperture of the latter, instead of being at the bottom, ought to be in the side, near one of the ends. If both rockets be fired at the same time, the latter will make the other revolve around the rope, while it advances along it.

*Of rockets which burn in the water.*—Though fire and water are two things of a very opposite nature, the rockets above described, when set on fire, will burn and produce their effect even in the water; but as they are then below the water the pleasure of seeing them is lost: for this reason, when it is required to cause rockets to burn as they float on the water, it will be necessary to make some change in the proportions of the moulds, and materials of which they are composed. In regard to the mould, it may be eight

or nine inches in length, and an inch in diameter: the former, on which the cartridge is rolled up, may be nine lines in thickness, and the rod for loading the cartridge must as usual be somewhat less. For loading the cartridge there is no need for a piercer with a nipple.

The composition may be made in two ways; for if it be required that the rocket, while burning on the water, should appear as bright as a candle, it must be composed of three materials mixed together, viz. three ounces of pulverised and sifted gunpowder, one pound of saltpetre, and eight ounces of sulphur. But, if you are desirous that it should appear on the water with a beautiful tail, the composition must consist of eight ounces of gunpowder pulverised and sifted, one pound of saltpetre, eight ounces of pounded and sifted sulphur, and two ounces of charcoal. When the composition has been prepared according to these proportions, and the rocket has been filled in the manner above described, apply a saucisson to the end of it; and having covered the rocket with wax, black pitch, resin, or any other substance capable of preventing the paper from being spoiled in the water, attach to it a small rod of white willow, about two feet in length, that the rocket may conveniently float.

If it be required that these rockets should plunge down, and again rise up, a certain quantity of pulverised gunpowder, without any mixture, must be introduced into them, at certain distances, such, for example, as two, three, or four lines, according to the size of the cartridge.

*Remarks.*—1. Small rockets of this kind may be made without changing the mould or composition, in several different ways, which, for the sake of brevity, we are obliged to omit. Such of our readers as are desirous of further information on this subject may consult those authors who have written expressly on pyrotechny.

2. It is possible also to make a rocket which, after it has burnt some time on the water, shall throw out sparks and stars; and these after they catch fire shall ascend into the air. This may be done by dividing the rocket into two parts, by means of a round piece of wood, having a hole in the middle. The upper part must be filled with the usual composition of rockets, and the lower with stars, which must be mixed with grained and pulverised gunpowder, &c.

3. A rocket which takes fire in the water, and, after burning there half the time of its duration, mounts into the air with great velocity, may be constructed in the following manner:—Take a flying rocket, furnished with its rod, and by means of a little glue attach it to a water-rocket, but only at the middle, in such a manner, that the latter shall have its neck uppermost, and the other its neck downward. Adjust to their extremity a small tube, to communicate the fire from one end to the other, and cover both with a coating of pitch, wax, &c., that they may not be damaged by the water. Then attach to the flying rocket, after it has been thus cemented to the aquatic one, a rod of the kind described in the second article; and suspend a piece of pack-thread to support a musket bullet made fast to the rod by means of a needle or bit of iron wire

When these arrangements have been made, set fire to the part after the rocket is in the water; and, when the composition is consumed, the fire will communicate through the small tube to the other rocket: the latter will then rise and leave the other, which will not be able to follow it, on account of the weight adhering to it.

**SECT. V.—BY MEANS OF ROCKETS TO REPRESENT SEVERAL FIGURES IN THE AIR.**

If several small rockets be placed upon a large one, their rods being fixed around the large cartridge which is usually attached to the head of the rocket, to contain what it is destined to carry up into the air; and these small rockets be set on fire while the large one is ascending, they will represent in a very agreeable manner a tree, the trunk of which will be the large rocket, and the branches the small ones. If these small rockets take fire when the large one is half burned in the air, they will represent a comet; and when the large one is entirely inverted, so that its head begins to point downwards, in order to fall, they will represent a kind of fiery fountain. If several serpents be attached to the rocket with a

piece of pack-thread, by the ends that do not catch fire; and if the pack-thread be sufficed to hang down two or three inches, between every two, this arrangement will produce a variety of agreeable and amusing figures.

*A rocket which ascends in the form of a screw.*—A straight rod, as experience shows, makes a rocket ascend perpendicularly, and in a straight line: it may be compared to the rudder of a ship, or the tail of a bird, the effect of which is to make the vessel or bird turn towards that side to which it is inclined; if a bent rod therefore be attached to a rocket, its first effect will be to make the rocket incline towards that side to which it is bent; but, its centre of gravity bringing it afterwards into a vertical situation, the result of these two opposite efforts will be that the rocket will ascend in a zig-zag or spiral form. In this case indeed, as it displaces a greater volume of air and describes a longer line, it will not ascend so high as if it had been impelled in a straight direction; but, on account of the singularity of this motion, it will produce an agreeable effect. For the military Congreve rocket, see **ROCKET**.

**PYRRHIA**, the daughter of Epimetheus and Pandora, and wife of Deucalion, king of Thesaly, in whose reign the flood happened. See **DEUCALION**. She was the mother of Amphycyon, Helen, and Protogenes, by Deucalion. Ovid, Met. i.

**PYRRHICHA**, in antiquity, a kind of exercise on a horseback, or a feigned combat, for the exercise of the cavalry. It was thus called from its inventor Pyrrhus of Cydonia, who first taught the Cretans to march in measure and cadence to battle, and to observe the time of the Pyrrhic foot. Others derive the name from Pyrrhus the son of Achilles, who instituted this exercise at the obsequies of his father. Aristotle says that it was Achilles himself who invented it. The Romans also called it ludus Trojanus, the Trojan game; and Aulus Gellius, decursus. It is represented on medals by two cavaliers in front running with lancers, and the word decursio in the exergue.

**PYRRHIC**, in the Greek and Latin poetry, a foot consisting of two syllables, both short; as deus. Among the ancients this foot is also called periambus; by others hegeмона.

**PYRRHO**, a Greek philosopher, born at Elis in Peloponnesus, who flourished about 300 B. C. He was the disciple of Anaxarchus, whom he accompanied as far as India, where he conversed with the Brahmins and Gymnosophists. He had made painting his profession before he studied philosophy. He established a sect whose fundamental principle was, that there is nothing true or false, right or wrong, honest or dishonest, just or unjust; or that there is no standard of any thing beyond law or custom, and that uncertainty and doubt belong to every thing. From this continual seeking after truth and never finding it, the sect obtained the name of Sceptics or Pyrrhonians from the founder. Pyrrho died about the ninetieth year of his age; his memory was honored with a statue at Athens, and a monument in his own country.

**PYRRHUS I.**, or Neoptolemus, the first king of Epirus, the son of Achilles and Deidamia. See **EPIRUS**. He was killed by Orestes in the temple of Delphi.

**PYRRHUS II.**, king of Epirus, the son of Æacides and Phthia, and a lineal descendant of Pyrrhus I.; celebrated for his war with the Romans. He conquered Antigonus, and reigned some time in Macedonia, but was at last killed at Argos, A. A. C. 272. See **ROME**.

**PYRRHONISM**, *n. s.* [From Pyrrho, the founder of the sceptics.] Scepticism; universal doubt.

As some ignorantly affect to be more knowing, so others vainly affect to be more ignorant than they are; who, to show they have greater insight and penetration than other men, insist upon the absolute uncertainty of science; will dispute even first principles; grant nothing as certain, and so run it into downright *pyrrhonism*; the too common effect of abstracted debates excessively refined. *Mason*.

**PYRUS**, the pear-tree, a genus of the pentagynia order and icosandria class of plants; natural order thirty-sixth, pomaceæ: CAL. quinquefid; petals five; fruit an apple, inferior, quinquelocular, and polyspermous. To this genus Linné has joined the apple and quince.

1. *P. communis*, the common pear-tree, rises with an upright large trunk, branching thirty or forty feet high, in some widely round, in others more erectly, and forming a conical head, oval, lanceolated, serrated leaves, and corymbose clusters of white flowers from the sides of the branches, succeeded by large fruit extended at the base. Under this species are comprehended almost endless varieties, all bearing the above description. They bear their flowers and fruit upon spurs, arising from the sides of the branches from two or three years old and upwards; the same branches and spurs continuing fruitful for a great number of years. The summer pears ripen in different sorts from the beginning of July until the middle or end of



September, and are generally fit to eat from the tree, or at least do not keep a week or two before they rot. The autumn pears come to perfection in October, November, and December; some ripening nearly on the tree in October and November, others requiring to lie some time in the fruitery, while some will keep two months; but all the winter pears, though they attain their full growth on the tree by the end of October and in November, yet they do not acquire perfection for eating till from the end of November to April and May. Those of each class have different properties; some being melting, others breaking, some mealy, and some hard and austere, fit only for kitchen uses. As many of the finest sorts were first obtained from France, they are still continued in most catalogues by French names. All the varieties of the pear-tree are hardy, and will succeed in any common soil of a garden or orchard. They are propagated by grafting and budding upon any kind of pear stocks; also occasionally upon quince stocks, and sometimes upon white thorn stocks; but pear stocks are greatly preferable to all others for general use.

2. *P. coronaria*, the sweet scented crab of Virginia, grows twelve or fifteen feet high, having angular serrated leaves, pedunculated umbels of whitish red, sweet-scented flowers, succeeded by small round crabs, remarkably sour and austere. There is one variety, called the evergreen Virginian crab-tree.

3. *P. cydonia*, the quince, formerly ranked by botanists as a distinct genus, but classed by Linné and his followers as a species of *pyrus*. It was formerly divided into three species, which must now rank as varieties; viz.

i. *P. cydonia lusitanica*, the Portugal quince, with obverse oval leaves, woolly on their under side:

ii. *P. cydonia maliforma*, with oval leaves, wholly on their under side, and lengthened at their base: and

iii. *P. cydonia oblonga*, with an oblong fruit lengthened at the base. There are some other varieties of this fruit, propagated in fruit gardens, and in the nurseries for sale; one of which is a soft eatable fruit, another very astringent, and a third with a very small fruit, cottony all over, which is scarcely worth keeping. These Mr. Miller supposed to be the seminal variations, but the three others to be distinct species. The Portugal quince is the most valuable; its pulp turns to a fine purple when stewed or baked, and becomes much softer and less austere than the others; it is therefore much fitter for making marmalade. These trees are all easily propagated, either by layers, suckers, or cuttings, which must be planted in a moist soil. Those raised from suckers are seldom so well rooted as those which are obtained from cuttings or layers, and are subject to produce suckers again in greater plenty; which is not so proper for fruit bearing trees. These trees require very little pruning; the chief thing to be observed is, to keep their stems clear from suckers, and cut off such branches as cross each other; likewise all upright luxuriant shoots from the middle of the tree should be taken off, that the head may not

be too much crowded with wood, which is of ill consequence to all fruit trees. These sorts may also be propagated by budding or grafting upon stocks raised by cuttings; so that the best sorts may be cultivated in this way in greater plenty than by any other method.

4. *P. malus*, the common apple-tree, grows twenty or thirty feet high, having oval serrated leaves and sessile umbels of whitish red flowers succeeded by large, roundish, and oblong fruit, concave at the base. The varieties of this species are amazingly great with respect to the differences of the fruit. Botanists say, that the wilding, or crab-apple of the woods and hedges is the original kind, and from the seeds of which the cultivated apple was first obtained. The varieties of this last no doubt are multiplied to some hundreds in different places, having been all first accidentally obtained from the seed or kernels of the fruit, and the approved sorts continued and increased by grafting upon crabs or any kind of apple stocks; but, although the number of varieties is very considerable, there are not above forty or fifty sorts retained in the nurseryman's catalogue. These varieties arrive at full growth in successive order from July to the end of October, improve in perfection after being gathered, and several of the winter kinds in particular, keep good for many months, even till the arrival of apples next summer. Among these various kinds of apples some are used for the dessert, some for the kitchen, and some for cyder making. All kinds of apples are propagated in the same manner as the pears, using apple stocks instead of pear stocks. They will succeed in any common soil of a garden or orchard, and in any free situation, except in a low and very moist soil, in which they are apt to canker, and very soon go off. In a friable loam they are generally very successful.

PYTHAGORAS, a celebrated philosopher of antiquity, respecting the time and place of whose birth critics are much divided. Dr. Bentley determines the date of his birth to be the fourth year of the forty-third Olympiad; Lloyd places it about the third year of the forty-eighth; and Dodwell fixes it in the fourth year of the fifty-second. It is generally believed that he was born in the island of Samos, and that he flourished about A. A. C. 500. His father Mnesarchus, who is said by some to have been a lapidary, and by others a merchant of Tyre, appears to have been a man of some distinction, and to have bestowed upon his son the best education. Of his childhood and early education we know nothing, except that he was first instructed in his own country by Creophilus, and afterwards in Scyros by Pherecydes. Poetry and music, eloquence and astronomy, became his studies; and in gymnastic exercises he often bore the palm for strength and dexterity. He first distinguished himself in Greece at the Olympic games, and soon after he commenced his travels. He visited Egypt, where, through the interest of Polycrates, tyrant of Samos, he obtained the patronage of king Amasis, by whose influence, with his own assiduity and perseverance, he gained the confidence of the priests; from whom he learned their sacred mysteries,

theology, and system of symbolical learning. In Egypt, too, he became acquainted with geometry, and the solar system; and made himself master of all the learning for which it was so famed among the nations of antiquity. It is said that he afterwards visited Persia and Chaldaea, where from the Magi he learnt divination, the interpreting of dreams, and astronomy. He likewise travelled into India, conversed with the Gymnosophists, and acquired from them a knowledge of the philosophy and literature of the east; and such was his ardor in the pursuit of science, that in quest of it, says Cicero, he crossed many seas, and travelled on foot through many barbarous nations. After he had spent many years in acquiring information on every subject, he returned to Samos, and attempted to institute a school for the instruction of his countrymen. Failing of success, he repaired to Delos, where he pretended to receive moral dogmas from the priestess of Apollo. He also visited Crete, where he was initiated into the most sacred mysteries of Greece. He went likewise to Sparta and Elis, and again assisted at the Olympic games; where, in the public assembly, he was saluted with the title of sophist, or wise man, which he declined. He returned to Samos, enriched with mythological learning and mysterious rites, and again instituted a school. His mysterious symbols and oracular precepts made this attempt more successful than the former; but, meeting with some opposition, he retired to Magna Græcia, and settled at Crotona. Here he founded the Italic sect; and his mental accomplishments, the fame of his travels, and his Olympic crown, soon procured him numerous pupils. His manly eloquence, and graceful delivery, attracted the most dissolute, and produced a remarkable change in the morals of the Crotonians. His influence was increased by the regularity of his own example, and its conformity to his precepts. He punctually attended the temples of the gods at an early hour; he lived upon the most simple food; clothed himself like the priests of Egypt; and, by his frequent purifications and regular offerings, appeared superior in sanctity to the rest of mankind. He endeavoured to delight his scholars with verse and music, by playing on his harp, and singing the pæans of Thales. Bodily exercises also made a considerable part of his discipline. At Crotona he had a public school for the general benefit of the people, in which he taught them virtue, condemning vice, and instructing them in the duties of social life. He also had a college in his own house, which he denominated *κοινύσιον*, in which there were two classes of students, viz. *ἐξωρετικοί*, or ascultantes, and *εσωρετικοί*. The former were probationers, and were kept under a long examen. A silence of five years was imposed upon them; which, according to Clemens Alexandrinus was to inure them to the pure contemplation of the Deity. The latter were called genuini, perfecti, mathematici; and, by way of eminence, Pythagoreans. They alone were admitted to the knowledge of the arcana of Pythagoric discipline, and the use of ciphers and hieroglyphics. The authority of Pythagoras among his pupils was so great that

it was even deemed a crime to dispute his word; and their arguments were considered as infallibly convincing, if they could enforce them by adding that the master said so. To give more weight to his exhortations, Pythagoras retired into a subterraneous cave, where his mother sent him intelligence of every thing which happened during his absence. After several months, he re-appeared on the earth with a grim and ghastly countenance, and declared in the assembly of the people that he was returned from Hades; which gave rise to many other fabulous reports. At length his singular doctrines, and perhaps his strenuously asserting the rights of the people against their tyrannical governors, raised a powerful party against him; which soon obliged him to fly for his life. His friends fled to Rhegium; and he himself, after being refused protection by the Locrians, fled to Metapontum, where he took refuge in the temple of the Muses, and where it is said he died of hunger about A. A. C. 497. The time, place, and manner of his death, however, are all very uncertain. After his death his followers paid the same respect to him as was paid to the gods; they erected statues in honor of him, converted his house at Crotona into a temple of Ceres, appealed to him as a deity, and swore by his name. Pythagoras married Theano of Crotona, or of Crete, by whom he had two sons, Telauges and Mnesarchus, who, after his death, took the management of his school. He also had a daughter called Damo. Whether he left any writings behind him is disputed. The golden verses, which Hierocles illustrated with a commentary, have been ascribed to Epicharmus or Empedocles, and contain a brief summary of his popular doctrines. From his mysterious secrecy, our information concerning his doctrine and philosophy is very uncertain. The purpose of philosophy, according to his system, is to raise the mind to the contemplation of immutable truth, and the knowledge of divine and spiritual objects. Mathematical science was with him the first step to wisdom, because it inures the mind to contemplation, and takes a middle course between corporeal and incorporeal beings. The whole science he divided into two parts, numbers and magnitude; and each of these he subdivided into two others, the former into arithmetic and music, and the latter into magnitude at rest and in motion; the former comprehending geometry, and the latter astronomy. Arithmetic he considered as the noblest science; and an acquaintance with numbers as the highest good. He considered numbers as the principles of every thing; and divided them into scientific and intelligible. Of the Monad, Duad, Triad, Tetrad, and Decad, various explanations have been given by various authors; but nothing certain is known of them. Music followed numbers, and was useful in raising the mind above the dominion of the passions. He invented the harmonical canon, or monochord; and the music of the spheres was a fanciful doctrine of Pythagoras. He reduced geometry to a regular science. A geometrical point, which he defines to be a monad, or unity with position, he says, corresponds to unity in arithmetic, a line to two, a

superficies to three, and a solid to four. God he considered as the universal mind, diffused through all things, and the self-moving principle of all things (*αυτοματιμος των παντων*), and of whom every human soul is a portion. Subordinate to the Deity there were, in the Pythagorean creed, three orders of intelligences, gods, demons, and heroes, of different degrees of excellence and dignity. These, together with the human soul, were considered as emanations from the Deity, the particles of subtle ether assuming a grosser clothing the farther they receded from the fountain. God himself was represented under the notion of monad, and the subordinate intelligences as numbers derived from, and included in, unity. Man was considered as consisting of an elementary nature, and a divine or rational soul. His soul, a self-moving principle, is composed of two parts; the rational, seated in the brain; and the irrational, including the passions, in the heart. In both these respects he participates with the brutes. The sensitive soul perishes; the other assumes an ethereal vehicle, and passes to the regions of the dead, will sent back to the earth to inhabit some other body brutal or human. See *METEMPSYCHOSIS*. It was this notion which led Pythagoras and his followers to abstain from flesh, and to be so peculiarly merciful to animals of every description. This doctrine is thus beautifully represented by Ovid, who introduces Pythagoras as saying;

‘Morte carent animæ: semperque priore relicta  
Sede, novis domibus habitant, vivuntque receptæ:  
Omnia mutantur: nihil interit; errat et illinc,  
Huc venit, hinc illuc, et quoslibet occupet artus  
Spiritus, eque feris humana in corpora transit,  
Inque feras noster: nec tempore deperit ullo,  
Utque novis fragilis signatur cera figuris,  
Nec manet ut fuerat, nec formas servat eadem,  
Sed tamen ipsa eadem est, animam sic semper eandem,  
Esse, sed in variis doceo migrare figuras.’

‘What then is death, but ancient matter drest  
In some new figure, and a varied vest?  
Thus all things are but altered, nothing dies;  
And here and there the unbodied spirit flies,  
By time, or force, or sickness dispossessed,  
And lodges where it lights, in man or beast;  
Or hunts without, till ready limbs it find,  
And actuates these according to their kind;  
From tenement to tenement is tost,  
The soul is still the same, the figure only lost:  
And, as the softened wax new seals receives,  
This face assumes, and that impression leaves;  
Now called by one, now by another name,  
The form is only changed, the wax is still the same;  
So death, thus called, can but the form deface,  
The immortal soul flies out in empty space,  
To seek her fortune in some other place.’

**PYTHEAS**, an eminent philosopher, astronomer, and geographer, born in Massilia in the age of Aristotle. He distinguished himself by his travels, as well as by his writings, all of which are now lost, though some of them were extant so late as the fifth century. He entered the sea, then unknown, now called the Baltic, and sailed as far as Thule. He was the first who established a distinction of climate by the length of days and nights.

**PYTHEUS**, a Lydian, famous for his riches, who is said to have entertained Xerxes, and all his numerous army, when going to invade Greece.

**PYTHIA**, or **PYTHONISSA**, the priestess of Apollo at Delphi, by whom he delivered oracles. She was so called from Pythius, a name of that god. The Pythia was at first required to be a young girl; but in latter times she was a woman of fifty years of age. The first and most famous Pythia was Phemonœe. Oracles were at first delivered by her in hexameter verse. All the Pythias were to be pure virgins, and all of them delivered their oracles with great enthusiasm and violent agitations. See *ORACLE* and *DELPHI*.

**PYTHIAN GAMES**, in Grecian antiquity, sports instituted near Delphos in honor of Apollo, on account of his slaying the serpent Python. See *APOLLO*. These games, at their first institution, were celebrated only once in nine years; but afterwards every fifth year, from the number of the Parnassian nymphs who came to congratulate Apollo, and to make him presents on his victory. The victor was crowned with garlands.

**PYTHON**, in fabulous history, a monstrous serpent, produced by the earth after Deucalion's deluge. Juno, being exasperated at Latona, who was beloved by Jupiter, commanded this serpent to destroy her; but, flying from the pursuit of the monster, she escaped to Delos, where she was delivered of Diana and Apollo; the latter of whom destroyed Python with his arrows, in memory of which victory the Pythian games were instituted. See *APOLLO*.

**PYX**, *n. s.* Lat. *pyxis*; Gr. *πυξίς*, a box. The box in which the Romanists keep the host.

*Pyxis* is a small metal case for containing the consecrated species in the Catholic church. Anciently it was made in the form of a dove, and suspended over the altar. *Dr. A. Kees.*

**PYX**. Lat. *pyxis*, from Gr. *πύξίς*. In archæology, a name given to the little casket in which the ancients often deposited their jewels and other ornaments. It was frequently of rich materials, and highly embellished; its shape was a long square, and it is often found represented on Greek vases.

## Q.

Q, the sixteenth letter of the alphabet, borrowed from the Latin or French, and for which the Saxons generally used *cp*, *cw*. The name of this letter is derived from Fr. *queue*, tail; its form being that of an U with a tail. The Q has this peculiar to it, that it is always followed by a U, and is therefore reckoned among the mutes. It is formed from the Hebrew *q*, *koph*; which most other languages have borrowed; though some of them have rejected it again, particularly the Greeks.

In effect, there is that resemblance between the Q and the C in some languages, and the K in others, that many grammarians, in imitation of the Greeks, banish the Q as a superfluous letter. Papias even affirms that all the Latin words now written with a Q were written among the ancient Romans with a C; but we want better authority for this. For though, in many cases, some write indifferently *quor*, or *cur*; *cum*, or *quum*; *quotidie*, or *cotidie*, &c., yet it does not thence follow that they ever wrote *cis*, *cæ*, *cid*, for *quis*, *quæ*, *quid*. Far from this, the ancients sometimes substituted Q for C; and wrote *quojus*, *quoi*, for *cujus*, *cui*, &c.

Varro, however, and some other grammarians, as we are told by Censorinus, &c., would never use the Q. The truth is, its use or disuse seems to have been so little settled and agreed on that the poets used the Q or C indifferently, as best suited their measures; it being a rule that the Q joined the two following vowels into one syllable; and that the C imported them to be divided. Hence it is that Lucretius uses *cuiet* for three syllables, in lieu of *quiret*; *acua* for *aqua*; and that Plautus uses *relicuum* for *reliquum*; as in

*Quod dedi, datum non vellem relicuum non;*

where the *cum* must be two syllables, otherwise the trochiac verse will be lame of a foot. In the French the sound of the Q and K are so near akin, that some of their nicest authors think the former might be spared. Ramus adds that till the establishment of royal professors in the university of Paris, under Francis I., they always used Q in the Latin the same as in the French; pronouncing *kis*, *kalis*, *kantus*, &c., for *quis*, *qualis*, *quantus*.

Some very learned men make Q a double letter as well as K and X. According to them, Q is evidently a C and U joined together, and they see the traces of the C U in the figure of the Q; the V being only laid obliquely, so as to come within the cavity of the C; as C <|

Q, among the ancients, was a numeral letter, signifying 500; as in the verse,

*Q velut A cum D quingentus vult numerare.*

A dash over it, as Q̄, denoted it to signify 500,000.

Q is also used as an abbreviation in several arts. Q. pl. in physicians' bills, stands for quantum placet, as much as you please; q. s. for quantum sufficit, or as much as is necessary. See ABBREVIATION.

QUACK, *v. n. & n. s.* Belg. *quacken*; Teut. *kuacken*; or from the sound. To cry as a goose or duck; be boisterously or chatteringly vain. hence, as a noun-substantive, a vain and boastful pretender to medicinal, or other arts.

Many poor country vicars, for want of other means, are driven to their shifts; to turn mountebanks, *quacksalvers*, and empyricks. *Burton.*

Believe mechanic *k virtuosi*

Can raise them mountains in Potosi,

Seek out for plants with signatures,

To *quack* of universal cures. *Hudibras.*

Saltimbancoes, *quacksalvers*, and charlatans deceive the vulgar in lower degrees; were Æsop alive, the Piazza and the Pont Neuf could speak their fallacies. *Browne.*

The change, schools, and pulpits are full of *quacks*, jugglers, and plagiarists. *L'Estrange.*

Ordinary *quacks* and charlatans are thoroughly sensible how necessary it is to support themselves by collateral assistances, and therefore always lay claim to some supernumerary accomplishments foreign to their profession. *Tatler.*

Wild ducks *quack* where grasshoppers did sing. *King.*

At the first appearance that a French *quack* made in Paris, a boy walked before him, publishing with a shrill voice, 'My father cures all sorts of distempers;' to which the doctor added in a grave manner, 'The child says true.' *Addison.*

Some *quacks* in the art of teaching pretend to make young gentlemen masters of the languages, before they can be masters of common sense. *Felton on the Classics.*

Despairing *quacks* with curses fled the place,

And vile attorneys, now an useless race. *Pope.*

QUADI, an ancient people of Germany, situated on the south-east of the mountains of Bohemia, on the banks of the Danube, and extending as far as the river Marus, or March, running by Moravia, which country they occupied.

QUADRA AND VANCOUVER'S ISLAND, an island on the north-west coast of North America, between Queen Charlotte's Sound and De Fuca's Straits. Nootka Sound lies not far from its south-west side. It was so named by Vancouver in honor of his meeting with signior Quadra, the officer who was commissioned by the court of Spain to cede, in the name of his court, the disputed territory of Nootka.

QUADRAGESIMAL, *adj.* Fr. *quadragesimal*; Lat. *quadragesima*. Lenten; belonging to or used in Lent.

I have composed prayers out of the church collects, adventual, *quadragesimal*, paschal, or pentecostal. *Sanderson.*

QUADRANGLE, *n. s.* Lat. *quadratus* and *angulus*. A square; a surface with four right angles.

My cholera being overblown

With walking once about the *quadrangle*,

I come to talk. *Shakspeare. Henry VI.*

The escorial hath a *quadrangle* for every month in the year. *Hovel.*

It was placed at a *quadrangular* table, opposite to the face-bearer. *Spectator.*

Common salt, shooteth into little crystals, coming near to a cube, sometimes into square plates, sometimes into short *quadrangular* prisms. *Grew.*

Each environed with a crust, conforming itself to the planes, is of a figure *quadrangular.* *Woodward.*

QUADRANS, a farthing, the fourth part of a penny. Before the reign of Edward I. the smallest coin was a sterling, or penny, marked with a cross; by the guidance of which a penny might be cut into halves for a halfpenny, or into quarters or four parts for farthings; till, to avoid the fraud of unequal cuttings, that king coined halfpence and farthings in distinct round pieces.

QUADRANT, *n. s.* *Lat. quadrans.*  
 QUADRANTIAL, *adj.* } The fourth part;  
 QUADRATE, *adj., n. s., &* } the quarter; the  
 QUADRATIC, *adj.* } *[v. n.]* quarter of a circle; an instrument for measuring altitudes: quadrate is square; four-fold; divisible into four parts; suited; fitted: a square; in astrology, an aspect of the heavenly bodies, wherein they are distant from each other ninety degrees, and the same with quartile: as a verb neuter, to suit; fit; be accommodated: quadratic, an algebraic term applied to such equations as retain, on the unknown side, the square of the root or the number sought: quadrature is the act of squaring; state of being square; a quadrature square; the first and last quarter of the moon.

And 'twixt them both a *quadrate* was the base,  
 Proportioned equally by seven and nine;  
 Nine was the circle set in heaven's place,  
 All which compacted, made a goodly diapase.

Whether the exact *quadrate* or the long square be the better is not well determined; I prefer the latter, provided the length do not exceed the latitude above one-third part. *Wotton.*

Some tell us that the years Moses speaks of were somewhat above the monthly year, containing in them thirty-six days, which is a number *quadrate.*

The word consumption, being applicable to a proper or improper consumption, requires a general description, *quadrate* to both. *Harvey.*

The powers militant  
 That stood for heaven, in mighty *quadrate* joined  
 Of union irresistible, moved on  
 In silence their bright legions. *Milton.*

All things parted by the 'empyrean bounds,  
 His *quadrature* from thy orbicular world, *Id.*  
 In sixty-three years may be lost eighteen days,  
 omitting the intercalation of one day every fourth year, allowed for this *quadrant* or six hours supernumerary. *Browne.*

The number of ten hath been extolled, as containing even, odd, long and plain, *quadrate* and cubical numbers. *Id.*

To our understanding a *quadrate*, whose diagonal is commensurate to one of the sides, is a plain contradiction. *Mors.*

The obliquity of the ecliptick to the equator, and from thence the diurnal differences of the sun's right ascensions, which finish their variations in each *quadrant* of the circle of the ecliptick, being joined to the former inequality, arising from the excentricity, makes these quarterly and seeming irregular inequalities of natural days. *Holdier on Time.*

It is full moon when, the earth being between the sun and moon, we see all the enlightened part of the moon; new moon when, the moon being between us and the sun, its enlightened part is turned from us: and half moon, when the moon being in the *quadratures*, we see but half the enlightened part. *Locke.*

Some had compasses, others *quadrants.* *Tatler.*  
 Aristotle's rules for epick poetry, which he had drawn from his reflections upon Homer, cannot be supposed to *quadrate* exactly with the heroick poems which have been made since his time; as it is plain his rules would have been still more perfect, could he have perused the *Aeneid.* *Addison.*

Thin taper sticks must from one centre part;  
 Let these into the *quadrant's* form divide. *Gau.*  
 Sir Isaac Newton discovered a way of attaining the quantity of all *quadrable* curves analytically, by his method of fluxions, some time before the year 1688. *Derham.*

To fill that space of dilating, proceed in straight lines, and dispose of those lines in a variety of parallels: and, to do that in a *quadrantal* space, there appears but one way possible; to form all the intersections, which the branches make, with angles of forty-five degrees only. *Id.*

The speculations of algebra, the doctrine of infinites, and the *quadrature* of curves, should not in-trench upon our studies of morality. *Watts.*

QUADRANT, in geometry, is the arch of a circle, containing 90°, or the fourth part of the entire periphery. Sometimes also the space or area included between this arch and two radii drawn from the centre to each extremity thereof, is called a quadrant, or more properly a quadrantal space, as being a quarter of an entire circle.

QUADRANT is also a mathematical instrument of great use in astronomy and navigation, for taking the altitudes of the sun and stars, and for taking angles in surveying, &c. It is variously contrived, and furnished with different apparatus, according to the various uses it is intended for. See ASTRONOMY and NAVIGATION. The common surveying quadrant is made of brass, wood, or any other solid substance; the limb of which is divided into 90°, and each of these farther divided into as many equal parts as the space will allow, either diagonally or otherwise. On one of these semidiameters are fitted two moveable sights; and to the centre is sometimes fixed a label, or moveable index, bearing two other sights; but in lieu of these last sights there is sometimes fitted a telescope; also from the centre there is hung a thread with a plummet; and on the under side or face of the instrument is fitted a ball and a socket, by which it may be put into any position. The general use of it is for taking angles in a vertical plane, comprehended under right lines going from the centre of the instrument, one of which is horizontal, and the other is directed to some visible point. But, besides the parts already described, there is frequently added on the face, near the centre, a kind of compartment, called the quadrat, or geometrical square. This quadrant may be used in different situations; for observing heights or depths, its plane must be disposed perpendicularly to the horizon; but, to take horizontal distances, its plane is disposed parallel thereto. Again, heights and distances

may be taken two ways, viz. by means of the fixed sights and plummet, or by the label.

**QUADRANT, GUNNER'S**, called also **gunners' square**, is that used for elevating and pointing cannon, mortars, &c., and consists of two branches, either of brass or wood, between which is a quadrantal arch divided into 90°, beginning from the shorter branch, and furnished with a thread and plummet. The use of the gunners' quadrant is extremely easy; for if the longest branch be placed in the mouth of the piece, and it be elevated till the plummet cut the degree necessary to hit a proposed object, the thing is done. Sometimes on one of the surfaces of the long branch are noted the divisions of diameters and weights of iron bullets, as also the bores of pieces.

**QUADRANT, GUNTER'S**, so called from its inventor Edmund Gunter, besides the usual apparatus of other quadrants, has a stereographical projection of the sphere on the plane of the equinoctial. It has also a kalendar of the months, next to the divisions of the limb.

**QUADRANT, HADLEY'S**, is an instrument of great utility both in navigation and practical astronomy. It is named from Mr. Hadley, who first published an account of it, though the invention originated with the celebrated Dr. Hooke, and was completed by Sir Isaac Newton. Its utility arises from the accuracy and precision with which it enables us to determine the latitude and longitude, and to it navigation is much indebted for the very great and rapid advances it has made of late years. It is easy to manage, and of extensive use, requiring no peculiar steadiness of hand, nor any such fixed basis as is necessary to other astronomical instruments. It is used for taking angles in maritime surveying, and with equal facility at the mast head as upon the deck, by which its sphere of observation is much extended; for supposing many islands to be visible from the mast head, and only one from deck, no useful observation can be made by any other instrument. By this angles may be taken at the mast head from the one visible object with great exactness; and further, taking angles from heights, as hills, or a ship mast's head, is almost the only way of exactly describing the figure and extent of shoals. It has been objected to the use of this instrument for surveying, that it does not measure the horizontal angles, by which alone a plan can be laid down. This objection, though true in theory, may be reduced in practice by a little caution; and Mr. Adams has given very good directions for doing so. No instrument has undergone, since the original invention, more changes than this quadrant. An essential and invaluable property, whereby it is rendered peculiarly advantageous in marine observations, is, that it is not liable to be disturbed by the ship's motion; for, provided the mariner can see distinctly the two objects in the field of his instrument, no motion nor vacillation of the ship will injure his observation.

**QUADRANT, MURAL.** See **ASTRONOMY**.

**QUADRANT OF ALTITUDE** is an appendage of the artificial globe, consisting of a lamina, or slip of brass, the length of a quadrant of one of the

great circles of the globe, and graduated. At the end, where the division terminates, is a nut rivetted on, and furnished with a screw, by means whereof the instrument is fitted on the meridian, and moveable round upon the rivet to all points of the horizon. Its use is to serve as a scale in measuring of altitudes, amplitudes, azimuths, &c.

**QUADRANTAL**, in antiquity, the name of a vessel in use among the Romans for the measuring of liquids. It was at first called amphora; and afterwards quadrantal, from its form, which was square every way like a die. Its capacity was eighty libræ, or pounds of water, which made forty-eight sextaries, two urnæ, or eight congii.

**QUADRATE**, a mathematical instrument, called also a geometrical square, and line of shadows: it is frequently an additional member on the face of the common quadrant, as also on those of Gunter's and Sutton's quadrants.

**QUADRATE**, in printing, a piece of metal used to fill up the void spaces between words, &c.

**QUADRATURE**, in astronomy, that aspect of the moon when she is 90° distant from the sun; or when she is in a middle point of her orbit, between the points of conjunction and opposition, namely, in the first and third quarters. See **ASTRONOMY**.

**QUADRATURE**, in geometry, denotes the reducing a figure to a square, or the finding of a square which shall contain just as much surface or area as a circle, an ellipsis, a triangle, &c., is the quadrature of a circle, ellipsis, &c. This question, especially among the ancient mathematicians, was a great postulatam. The quadrature of rectilinear figures is easily found, for it is merely the finding their areas or surfaces, i. e. their squares; for the squares of equal areas are easily found by only extracting the roots of the areas thus found. The quadrature of the curvilinear spaces is of more difficult investigation; and in this respect extremely little was done by the ancients, except the finding the quadrature of the parabola by Archimedes. This he obtained in a very ingenious manner, by inscribing an isosceles triangle in the parabola, then two isosceles triangles on the equal sides of the former, four others on these, and so on, which he found to have a certain relation, decreasing in the proportion 1,  $\frac{1}{4}$ ,  $\frac{1}{9}$ , &c., the infinite sum of which series would therefore express the area of the parabola, or the area of all the triangles of which he thus conceived it to be composed; and which sum he found to be one and one-third, or two-thirds of the circumscribing rectangle. After this time, a period of near 2000 years elapsed without producing the quadrature of a single curvilinear figure, although the subject seems to have engaged the attention of the most eminent mathematicians during that long interval, particularly the quadrature of the circle. This figure, being the most simple in appearance and construction of any contained under a curve line, was well calculated to excite the curiosity of mathematicians. Archimedes doubtless attempted the solution of this problem; but, failing in producing the exact quadrature, he contented himself with giving an

approximation, showing by the inscription and circumscription of a polygon of ninety-six sides, that the diameter being 1, the circumference was greater than  $3\frac{1}{4}$ , but less than  $3\frac{1}{2}$ .

It would be useless to attempt in this place to enumerate the various absurd quadratures which have been, from time to time, published by minor geometers, with all that conceit and confidence which seldom fail to accompany inferiority. Some attributed their success to divine inspiration; others to their own superior talents: some offered large sums of money to those who should discover any error in their investigation, while others expected great rewards from their government as a recompence for their discovery, foolishly attaching great importance to a problem, which, if it could be accurately solved, would serve no other purpose but to gratify the curiosity of mathematicians. Towards the year 1585, Metius, combatting the false quadrature of Simon Duchène, gave the ratio of 113 to 355, which is very exact. Vieta found a still nearer approximation, carrying it to ten places of decimals, whereas the former is true only to six places.

Adrianus Romanus carried the approximation to seventeen figures, and Ludolph Van Ceulen to thirty-six; which he published in his work, *De Circulo et Adscriptis*; and of which Snellius published a Latin translation in 1619. He afterwards verified Van Ceulen's approximation by some theorems of his own invention, which greatly facilitated the computation, and which he published in 1621, under the title of *Willebrordi Snellii Cyclometricus de Circuli Dimensione, &c.*

Descartes gave a geometrical construction from which it was easy to draw an expression in the form of a series; and Huygens afterwards discovered some curious theorems connected with this subject, and formed some useful rules for approximating towards the length of the circular arc.

A curious discovery connected with this subject was given by Wallis in his *Arithmetica Infinitorum*, in 1655: where he shows that the ratio of a circle to the square of its diameter is truly expressed by the infinite fraction.

$$\frac{3^2 \cdot 5^2 \cdot 7^2 \cdot 9^2 \cdot 11^2 \cdot \&c.}{2 \cdot 4^2 \cdot 6^2 \cdot 8^2 \cdot 10^2 \cdot 12^2 \cdot \&c.}$$

Such was the progress which mathematicians had made towards the solution of this interesting problem prior to the invention of fluxions, which, by reducing the quadrature of all curves to one general principle, again revived the hopes of success with regard to the circle, notwithstanding some pretended demonstrations of its impossibility; and its quadrature was accordingly again attempted with the greatest eagerness. The quadrature of a space, and the rectification of a curve, were now reduced to that of finding the fluent of a given fluxion but still the problem was found to be incapable of a general solution in infinite terms. The fluxion of a given fluent was found to be always assignable, but the converse proposition, viz. of finding the fluent of a given fluxion, could only be effected in particular cases; and amongst the

exceptions, to the great regret and disappointment of geometricians, was included the case of the circle with regard to every form of fluxion under which it could be obtained. Mr. Glenie in 1812 read a paper before the Royal Society to prove that the true geometrical quadrature of the circle was impossible; which is now indeed generally allowed.

QUADRATUS, a native of Athens, where he was educated, and became a disciple of the apostles. About A. D. 125, when the emperor Adrian visited Athens, and was initiated into the Eleusinian mysteries, a persecution of the Christians arose, wherein Publius bishop of Athens suffered martyrdom. Quadratus succeeded him, and wrote an Apology for the Christians, which he presented to the emperor, who thereupon stopt the prosecution. This work is lost, but was extant in the time of Eusebius, who says it showed the genius of the author, and the true doctrine of the apostles. Quadratus was banished from Athens, but nothing certain is recorded of his death.

QUADRATUS, a surname of Mercury, because some of his statues were square.

QUADREL, in building, a kind of artificial stone, so called from its being square. The quadrels are made of a chalky earth, &c., and dried in the shade for two years. These were formerly in great request among the Italian architects.

QUADRIFRONS, AND QUADRICEPS, surnames of Janus, because he was represented with four heads and four faces.

QUADRIGA, in antiquity, a car or chariot drawn by four horses. On the reverses of medals, we frequently see the emperor or Victory in a quadriga, holding the reins of the horses; whence these coins are, among the curious, called *nummi quadrigati* and *victoriatii*.

QUADRILATERAL, *adj.* Fr. *quadrilatere*; Lat. *quatuor* and *latus*. Having four sides.

Tin, incorporated with crystal, disposes it to shoot into a quadrilateral pyramid, sometimes placed on a quadrilateral base or column. *Woodward.*

QUADRILLE, a game played by four persons, with forty cards; which are the remains of a pack, after the four tens, nines, and eights are discarded; these are dealt three and three, and one round four, to the right hand player; and the trump is made by him that plays with or without calling, by naming spades, clubs, diamonds, or hearts, and the suit named is trumps.

QUADRIO (Francis Xavier), a learned Jesuit, born in the Valteline in 1695. He afterwards became secular priest, and died at Milan in 1756. He published, 1. *A Treatise on the Italian Poetry*. 2. *A History of Italian Poetry*, in 7 vols. 3. *Dissertations upon the Valteline*, in 3 vols.

QUADRUPED, *n. s.* Fr. *quadrupede*; Lat. *quadrupes*. An animal that goes on four legs.

The different flexure and order of the joints is not disposed in the elephant as in other quadrupeds.

*Browne.*  
The fang teeth, eye teeth, or dentes canini of some quadruped. *Woodward on Fossils.*

Most *quadrupedes*, that live upon herbs have incisor teeth to pluck and divide them. *Arbutnot.*

The king of brutes,

Of *quadrupeds* I only mean. *Swift.*

The cockney, travelling into the country, is surprized at many actions of the *quadruped* and winged animals. *Watts's Logic.*

QUADRUPEDS, in zoology, those animals which have four limbs or legs proceeding from the trunk of their body. See ZOOLOGY.

QUADRUPLE, *adj.* Fr. *quadruple*; Lat. *quadruplus*. Fourfold; four times told.

A law, that to bridle theft doth punish thieves with a *quadruple* restitution, hath an end which will continue as long as the world itself continueth.

The lives of men on earth might have continued double, treble, or *quadruple*, to any of the longest times of the first age. *Hooker.*

Fat refreshes the blood in the penury of aliment during the winter, and some animals have a *quadruple* caul. *Raleigh.*

If the person accused maketh his innocence appear, the accuser is put to death, and out of his goods the innocent person is *quadruply* recompensed. *Arbutnot on Aliments.*

QU'ERE. Lat. *quære*. Enquire; seek; a word put when any thing is recommended to enquiry. *Swift.*

*Quære*, if it is steeped in the same liquor, it may not prevent the fly and grub. *Mortimer's Husbandry.*

To *QUAFF*, *v. a.* Junius derives this word from the Greek *κρᾶσιζειν* in the Æolic dialect used for *κρᾶθιζειν*. Skinner from *go off*, as *go off*, *guoff*, *quoff*, *quaff*. It comes from Fr. *coqfer*, to be drunk, says Johnson: Swed. *quäfa*, from Goth. *kaf*, deep. Thomson. To drink; swallow in large draughts.

QUAGGA (*equus quagga*). This animal, which is an inhabitant of the southern parts of Africa, is not unlike the zebra; its ears, however, are shorter, and it is not marked with stripes on its fore legs or hinder parts; its rump is of a grayish color, and its belly, legs, and tail whitish. The *quagga* is a social animal, living in large troops, is far more tractable than the zebra, and is said to be occasionally used in the Cape of Good Hope for domestic purposes. Notwithstanding this mildness of character when domesticated, it is exceedingly fearless in its native plains, and is even said to be more than a match for the *hyæna*, fighting desperately both with its hoofs and teeth. It will breed with the common horse; a mixed race of this kind, possessing great beauty of form, and retaining, in a great degree, the characteristic markings of the *quagga*, existed in England some years since. The *quagga* has received a variety of names from authors; thus Pennant terms it the *quacha*, Masson the *opeagha*, and Sparrman calls it by the name here adopted. It should be remarked that Edwards has mistaken it for the female zebra.

QUAG'MIRE, *n. s.* Quake and mire. A shaking marsh; a bog that trembles under the feet.

The fen and *quagmire*, so marsh by kind, are to be drained. *Tusser.*

VOL. XVII.

The brain is of such a clammy consistence that it can no more retain motion than a *quagmire*.

*Glanville's Scepsis.*

The wet particles might have easily ever mingled with the dry, and so all had either been sea or *quagmire*. *More.*

QUAID, *part.* 'Of this participle I know not the verb,' says Johnson, 'and believe it only put by Spenser, who often took great liberties, for quailed.' But it is nearer *cowed* both in sound and signification. Dejected; depressed; crushed.

Therewith his sturdy courage soon was *quaid*,  
And all his senses were with a sudden dread dismayed. *Spenser.*

QUAIGH, or *QUAFF*, a kind of drinking vessel, peculiar to the Highlands, made of different pieces of wood, of various colors joined together by small hoops. They are made of various sizes, to hold from a gill, (or quartern) to a pint or even a quart of Scottish measure. The small ones have two handles (or lugs as they are called) projecting from the brim; the large have four.

QUAIL, *v. n. & v. a.* Belg. *quelen*; Teut. *qual*, is sickness. To languish; lose spirits; sink into dejection; decline: crush; quell.

After Solyman had with all his power in vain besieged Rhodes, his haughty courage began to *quail*, so that he was upon point to have raised his siege. *Knolles.*

To drive him to despair, and quite to *quail*,  
He shewed him painted in a table plain  
The damned ghosts. *Spenser.*

This may plant courage in their *quailing* breasts,  
For yet is hope of life and victory. *Shakspeare.*

While rocks stand,  
And rivers stir, thou can'st not shrink or *quail*;  
Yea, when both rocks and all things shall disband,  
Then shalt thou be my rock and tower. *Herbert.*

To pass the *quailing* and withering of all things by the recess, and their reviving by the reaccess of the sun, the sap in trees precisely follows the motion of the sun. *Hakewill.*

Three, with fiery courage, he assails;  
Three, as kings adorned in royal wise;  
And each successive after other *quails*,  
Still wond'ring whence so many kings should rise. *Daniel.*

QUAIL, *n. s.* Fr. *caille*; Ital. *quaglia*; Belg. *quackel*; barb. Lat. *quaquila*. A bird of game and passage.

His *quails* ever

Beat mine. *Shakspeare. Antony and Cleopatra.*  
Hen birds have a peculiar sort of voice, when they would call the male, which is so eminent in *quails*, that men, by counterfeiting this voice with a *quail-pipe*, easily draw the cocks into their snares.

*Ray on the Creation.*

A dish of wild fowl furnished conversation, concluded with a late invention for improving the *quail-pipe*. *Addison.*

A fresher gale

Sweeping with shadowy gust the field of corn,  
While the *quail* clamours for his running mate. *Thomson.*

QUAIL, in ornithology. See PERDIX.

QUAIL-PIPES, or *quail-calls*, are made of a small leather purse, about two fingers wide, and four fingers long, in the shape of a pear; this is stuffed half full of horse-hair, and at the end of



it is placed a small whistle, made of the bone of a rabbit's leg, about two inches long, and the end formed like a flageolet, with a little soft wax. This is the end fastened into the purse; the other is closed up with the same wax, only a hole is opened with a pin, to make it give a distinct and clear sound. To make this sound, it must be held full in the palm of the hand, with one of the fingers placed over the top of the wax; then the purse is to be pressed, and the finger is to shake over the middle of it, to modulate the sound it gives into a sort of shake. This is the most useful call; for it imitates the note of the hen-quail, and seldom fails to bring a cock to the net if there be one near the place. The call that imitates the note of the cock, and is used to bring the hen to him, is to be about four inches long, and above an inch thick; it is to be made of a piece of wire turned round and curled, and covered with leather; and one end of it must be closed up with a piece of flat wood, about the middle of which there must be a small thread or strap of leather, and at the other end is to be placed the same sort of pipe, made of bone, as in the other call. The noise is made by opening and closing the spiral.

**QUAINT**, *adj.* } Fr. *coint*; of Lat. *comp-*  
**QUAINTLY**, *adv.* } *tus*. Nice; minutely ex-  
**QUAINTNESS**, *n. s.* } act; having petty ele-  
 gance; subtle; sly; fine-spun; affected: Spenser  
 uses it for quailed.

As clerkes been full subtle and *quaint*. *Chaucer*.  
 Each ear sucks up the words a true love scattereth  
 And plain speech oft, than *quaint* phrase framed is.

*Sidney.*

With such fair slight him Guyon failed:  
 Till at the last, all breathless, weary and faint,  
 Him spying, with fresh onset he assailed,  
 And kindling new his courage, seeming *quaint*,  
 Struck him so hugely, that through great constraint  
 He made him stoop. *Spenser.*

You were glad to be employed,  
 To shew how *quaint* an orator you are.

*Shakspeare.*

I never saw a better fashioned gown,  
 More *quaint*, more pleasing, or more commendable.

*Shakspeare.*

Breathe his faults so *quaintly*,  
 That they seem the taints of liberty,  
 The flash and outbreak of a fiery mind. *Id.*  
 When was old Sherewood's hair more *quaintly*  
 curled,  
 Or nature's cradle more enchased and purld?

*Ben Jonson.*

What's the efficient cause of a king? surely a  
*quaint* question; yet a question that has been moved.

*Holyday.*

He his fabrick of the heav'n's  
 Hath left to their disputes, perhaps to move  
 His laughter at their *quaint* opinions wide  
 Hereafter. *Milton's Paradise Lost.*  
 He spends some passages about two similitudes;  
 one of mine, and another *quainter* of his own.

*Stillingfleet.*

As my Buxom  
 With gentle finger, stroaked her milky care,  
 I *quaintly* stole a kiss. *Gay.*  
 There is a certain majesty in simplicity, which is  
 far above all the *quaintness* of wit. *Pope.*

To this we owe those monstrous productions,  
 which under the name of trips, spies, amusements,  
 and other conceited appellations, have overrun us;

and I wish I could say, those *quaint* foppeties were  
 wholly absent from graver subjects. *Swift.*

**QUAKE**, *v. n. & n. s.* Sax. *cpacan*; Lat. *qualto*  
 To shake; to tremble with cold or fear; to be  
 yielding; not solid or firm; a shudder.

The mountains *quake* at him, and the hills melt,  
 and the earth is burnt at his presence. *Nahum. i. 5.*

Dorus threw Pamela behind a tree, where she  
 stood *quaking* like the partridge on which the hawk  
 is ready to seize. *Sidney.*

Do such business as the better day  
 Would *quake* to look on. *Shakspeare. Hamlet.*

As the earth may sometimes shake,  
 For winds shut up will cause a *quake*;  
 So often jealousy and fear  
 Stol'n to mine heart, cause tremblings there.

*Suckling.*

The *quaking* powers of height stood in amaze.

*Cowley.*

In fields they dare not fight, where honour calls,  
 The very noise of wars their souls does wound,  
 They *quake* but hearing their own trumpets sound.

*Dryden.*

Next Smedley dived; slow circles dimpled o'er  
 The *quaking* mud, that clos'd and op'd no more.

*Pope.*

**QUAKERS.** See FRIENDS.

**QUALIFY**, *v. a. & v. n.* } Fr. *qualifier*;  
**QUALIFICATION**, *n. s.* } of Lat. *qualis* and  
*facere*. To fit or furnish; make capable of;  
 hence reduce; assuage; modify; abate: as a  
 verb neuter, fit one's self: qualification is, ac-  
 complishment; fitness; that which fits or quali-  
 fies; abatement; modification.

He balms and herbs thereto applied,  
 And evermore with mighty spells them charmed,  
 That in short space he has them *qualified*,  
 And him restored to health that would have dy'd.

*Spenser.*

That which ordinary men are fit for, I am *qualified*  
 in; and the best of me is diligence. *Shakspeare.*

I do not seek to quench your love's hot fire,  
 But *qualify* the fire's extreme rage,  
 Lest it should burn above the bounds of reason.

*Id.*

I have drunk but one cup to-night, and that was  
 craftily *qualified* too; and behold what innovation it  
 makes here. *Id.*

It hath so pleased God to provide for all living  
 creatures, wherewith he hath filled the world, that  
 such inconveniences as we contemplate afar off are  
 found by trial, and the witness of men's travels, to  
 be so *qualified*, as there is no portion of the earth  
 made in vain. *Raleigh's History of the World.*

Place over them such governors, as may be *quali-*  
*fied* in such manner as may govern the place.

*Bacon.*

They would report that they had records for twenty  
 thousand years, which must needs be a very great  
 untruth, unless we will *qualify* it, expounding their  
 years not of the revolution of the sun, but of the  
 moon. *Abbot.*

It hath no larinx or throttle to *qualify* the sound.

*Brown.*

So happy 'tis you move in such a sphere,  
 As your high majesty with awful fear  
 In human breasts might *qualify* that fire,  
 Which kindled by those eyes had flamed higher.

*Walter.*

Children should be early instructed in the true  
 estimate of things, by opposing the good to the  
 evil, and compensating or *qualifying* one thing with  
 another. *L'Estrange.*

Good *qualifications* of mind enable a magistrate to perform his duty, and tend to create a public esteem of him.

*Aterbury.*  
My proposition I have *qualified* with the word often; thereby making allowances for those cases, whereby men of excellent minds may, by a long practice of virtue, have rendered the heights and rigours of it delightful.

*Id.*  
It is in the power of the prince to make piety and virtue become the fashion, if he would make them necessary *qualifications* for preferment.

*Swift.*  
After mentioning the corporation and test acts, and some others which do not relate to the point under consideration, it is enacted that persons who, after the passing of the act, have omitted to *qualify* in the manner prescribed by those acts, and who shall properly *qualify* before the 25th of the ensuing December, shall be indemnified against all penalties, forfeitures, incapacities, and disabilities; and their elections, and the acts done by them, are declared to be good.

*Tomlin's Law Dictionary.*  
**QUALITY**, *n. s.* Fr. *qualité*; Lat. *qualitas*. Nature considered relatively; property; adjunct; disposition of mind or temper; qualification; rank: hence persons of high rank collectively considered.

These, being of a far other nature and *quality*, are not so strictly or everlastingly commended in scripture.

*Hooker.*  
It is with the clergy, if their persons be respected, even as it is with other men; their *quality* many times far beneath that which the dignity of their place requireth.

*Id.*  
In the division of the kingdom, it appears not which of the dukes he values most; for *qualities* are so weighed, that curiosity in neither can make choice of either's moiety.

*Shakespeare.*  
O, mickle is the powerful grace, that lies  
In plants, herbs, stones, and their true *qualities*.

*Id.*  
Let him be so entertained, as suits with gentlemen of your knowing to a stranger of his *quality*.

*Id. Cymbeline.*  
The attorney of the duchy of Lancaster partakes of both *qualities*, partly of a judge in that court, and partly of an attorney-general.

*Bacon.*  
The matter is, whether he be a man of such *quality* that the state allows him to have a dove-house.

*Selden.*  
He had those *qualities* of horsemanship, dancing, and fencing, which accompany a good breeder.

*Clarendon.*  
The masters of these horses may be admitted to dine with the lord lieutenant: this is to be done, what *quality* soever the persons are of.

*Temple.*  
One doubt remains, said I, the dames in green,  
What were their *qualities*, and who their queen?

*Dryden.*  
The power to produce any idea in our mind, I call *quality* of the subject, wherein that power is.

*Locke.*  
Since the event of an action usually follows the nature or *quality* of it, and the *quality* follows the rule directing it, it concerns a man, in the framing of his actions, not to be deceived in the rule.

*South.*  
I shall appear at the masquerade, dressed up in my feathers, that the *quality* may see how pretty they will look in their travelling habits.

*Addison.*  
People of *quality* are fine things, indeed, if they had but a little more money; but for want of that they are often forced to do things they are ashamed of.

*Vanburgh.*  
No sensible *qualities*, as light and color, heat and

sound, can be subsistent in the bodies themselves absolutely considered, without a relation to our eyes and ears, and other organs of sense: these *qualities* are only the effects of our sensation, which arise from the different motions upon our nerves from objects without, according to their various modification and position.

*Bentley.*  
Of all the servile herd, the worst is he,  
That in proud dullness joins with *quality*,  
A constant critick at the great man's board,  
To fetch and carry nonsense for my lord.

*Pope.*  
We, who are hearers, may be allowed some opportunities in the *quality* of standers-by.

*Swift.*  
To *quality* belongs the highest place,  
My lord comes forward; forward let him come!  
Ye vulgar! at your peril give him room.

*Young.*  
Nothing discovers the true *quality* and disposition of the mind more, than the particular kind of knowledge it is most fond of.

*Mason.*  
**QUALM**, *n. s.* } Sax. *cpealm*; Dan. and  
**QUALM'ISH**, *adj.* } Teut. *qualm*. A sudden fit of sickness; sudden seizure of languor: the adjective corresponding.

Some sudden *qualm* hath struck me to the heart,  
And dimmed mine eyes, that I can read no further.

*Shakespeare.*  
I am *qualmish* at the smell of leek.

*Id.*  
Compared to these storms, death is but a *qualm*,  
Hell somewhat lightsome, the Bermudas calm.

*Donne.*  
I find a cold *qualm* come over my heart, that I faint,  
I can speak no longer.

*Hovell.*  
All maladies  
Of ghastly spasm, or racking torture *qualms*  
Of heart-sick agony.

*Milton's Paradise Lost.*  
For who, without a *qualm*, hath ever looked  
On holy garbage, though by Homer cooked?

*Roscommon.*  
Thy mother well deserves that short delight,  
The nauseous *qualms* of ten long months and travail  
to delight.

*Dryden's Virgil.*  
You drop into the place,  
Careless and *qualmish* with a yawning face.

*Dryden.*  
They have a sickly uneasiness upon them, shifting  
and changing from one error, and from one *qualm*  
to another, hankering after novelties.

*L'Estrange.*  
The *qualms* or ruptures of your blood  
Rise in proportion to your food.

*Prior.*  
When he hath stretched his vessels with wine to their utmost capacity, and is grown weary and sick, and feels those *qualms* and disturbances that usually attend such excesses, he resolves that he will hereafter contain himself within the bounds of sobriety.

*Calamy.*  
**QUANGSEE**, a province of the south-western frontier of China, bordering on Tonquin. East and north it is flat, but fertile, and yields rice for export. The rest of the province consists of lofty mountains, covered with wood, and containing mines of gold, silver, copper, and tin, which have only of late been allowed to be worked on condition of their paying forty per cent. to the emperor, and five per cent to the officers and troops employed in superintending them. The gold mines, however, were retained by the emperor in his own hands. The *quanglang* tree, of the pith of which bread is made, is indigenous here; as well as a species of cinnam-

mon. Sir G. Staunton reckons the inhabitants at 10,000,000. The capital is called Kouelong or Queyling.

QUANTITY, *n. s.* } *Fr. quantité; Ital. quan-*  
 QUANTITATIVE, } *tita; Lat. quantitas.* Ex-  
 QUANTUM, *n. s.* } tent; bulk; bigness or  
 smallness of size or number; part; portion; a  
 large portion; measure of time in pronunciation:  
 quantitative is estimable by quantity: quantum,  
 amount; sum.

If I were sawed into quantities, I should make  
 four dozen of such bearded hermites staves as master  
 Shallow.

*Shakespeare.*

So varying still their moods, observing yet in all  
 Their quantities, their rests, their censures metrical.

*Draughton.*

This explication of rarity and density, by the com-  
 position of substance with quantity, may give little  
 satisfaction to such who are apt to conceive therein  
 no other composition or resolution but such as our  
 senses shew us, in compounding and dividing bodies  
 according to quantitative parts.

*Digby.*

The easy pronunciation of a mute before a liquid  
 does not necessarily make the preceding vowel, by  
 position, long in quantity; as patrem.

*Holder.*

Unskilled in hellebore, if thou shou'dst try

To mix it, and mistake the quantity,

The rules of physick wou'd against thee cry.

*Dryden.*

The warm antiscorbutical plants, taken in quan-  
 tities, will occasion stinking breath, and corrupt the  
 blood.

*Arbutnot.*

Quantity is what may be increased or diminished.

*Cheyne.*

The quantum of presbyterian merit, during the  
 reign of that ill-advised prince, will easily be com-  
 puted.

*Swift.*

QUANTITY.—To define what the ancient quan-  
 tity was, in the age when its nature was not  
 determinable merely from the mouldering manu-  
 scripts, or hieroglyphic symbols of our modern  
 copyists; but when the criteria for the ear, which  
 Quintilian declares cannot be imitated  
 except orally, were obtained from the only ef-  
 fectual source, the viva vox, is an arduous and  
 almost hopeless task. From the ashes, how-  
 ever, we have gleaned together with other anti-  
 quarians our quota; and from the scattered  
 fragments, imperfect records, and broken monu-  
 ments of the general ruin, have collected what  
 we call our rules.

It is clear that in the ancient elocution there  
 were not only fifteen vowel sounds, represented  
 by six letters, but each of these was again sus-  
 ceptible of one of the three accents, the acute,  
 the grave, or the circumflex. And though the  
 Greeks remedied this in part, by two additional  
 characters, yet to express the mere duration of  
 their syllables, there is still an obvious defi-  
 ciency. Every intelligent observer will admit  
 that elocution is nothing but a species of music,  
 since every thing implied by the duration of a  
 syllable, the mood or general time of delivery,  
 accent, emphasis, pause, tone, and cadence, are  
 properties which may be very adequately ex-  
 pressed on paper, in musical composition, or,  
 more completely, by a good organ. Hence the  
 duration of a syllable is perfectly analogous to  
 the relative difference between a minim and a  
 crotchet; the mood, to the general time, whether  
 quick or slow, observed in the whole compo-

sition; accent and emphasis, being an elevation  
 or depression of the voice, are actually the vari-  
 ation from one note to another; pause is, by  
 musicians, under the term a rest, only changed  
 in name; while tone, implying all that modu-  
 lation of the voice effected by the tranquil,  
 plaintive or impassioned mind, is what the  
 complete organ very nearly effects by its dia-  
 pason, sesquialter, principal, and occasionally  
 by the swell; and the cadence is but the return  
 of the air and notes to the same key to which  
 the whole composition is set. We now easily  
 perceive that of all that once gave eloquence to  
 the orations of Cicero, and harmony to the  
 strains of Virgil, we now retain but a concate-  
 nation of vowels and consonants, in fact, but a  
 lifeless syllabication. Notwithstanding, how-  
 ever, this latitude for doubt, and the difficulties  
 to which the question is liable, several with  
 little hesitation define the quantity of a syllable  
 to be the duration of the voice in pronouncing  
 it. But whilst this, on the one hand, renders  
 the whole poetic fabric consistent, it is, on the  
 other, not a little at variance with the customary  
 and established pronunciation of many who  
 are amongst the principal advocates of prosodial  
 orthoepy, as well as with the manner in which  
 the Latin language is frequently pronounced  
 among the moderns, and by the British nation.  
 To youth we prescribe the laws of quantity,  
 and we oblige them to pronounce the first syl-  
 lable of præfugus short, and that of cōpia long,  
 because the former is a tribrac, and the latter a  
 dactyl; but we not only allow them, but accus-  
 tom ourselves to pronounce nepos, fides, glōbus,  
 and conjūgium, as though these several syllables  
 were respectively long, and are accused by foreign-  
 ers not only of departing from the genuine sound  
 of the Greek and Latin vowels, but of violating  
 the quantity of these languages more than any  
 other European nation. The author of the Essay  
 on the Harmony of Languages gives us a detail of  
 the particulars by which this accusation is  
 proved, so accurate as to give it claim to cita-  
 tion here. 'The falsification of the harmony by  
 English scholars in their pronunciation of  
 Latin, with regard to essential points, arises  
 from two causes only: first, from a total inat-  
 tention to the length of vowel sounds, making  
 them long or short merely as chance directs;  
 and, secondly, from sounding doubled conso-  
 nants as only one letter. The remedy of the  
 last fault is obvious. With regard to the first,  
 we have already observed that each of our vowels  
 has its general long sound, and its general short  
 sound totally different. Thus, the short sound of  
 e lengthened is expressed by the letter a, and  
 the short sound of i lengthened is expressed by  
 the letter e. And with all these anomalies, usual  
 in the application of vowel characters to the  
 vowel sounds of our own language, we proceed  
 to the application of vowel sounds to the vowel  
 characters of the Latin. Thus, in the first syl-  
 lable of sidus and nōmen, which ought to be  
 long, and of miser and dñus, which ought to be  
 short, we equally use the common long sound  
 of the vowels; but, in the oblique cases, siederis,  
 nominis, miseri, oneris, &c., we use quite ano-  
 ther sound, and that a short one. These strange  
 anomalies are not in common to us with our

southern neighbours the French, Spaniards, and Italians. They pronounce *sidus*, according to our orthography, *seedus*, and in the oblique cases preserve the same long sound of the *i*. Nomen they pronounce as we do, and preserve, in the oblique cases, the same long sound of the *o*. The Italians also, in their own language, pronounce doubled consonants as distinctly as the two most discordant mutes of their alphabet. It is a matter of curiosity to observe with what regularity we use these solecisms in the pronunciation of Latin. When the penultimate is accented, its vowel, if followed but by a single consonant, is always long, as in Dr. Foster's examples. When the antepenultimate is accented, its vowel is, without any regard to the requisite quantity pronounced short, as in *mirabile*, *frigidus*; except the vowel of the penultimate be followed by a vowel, and then the vowel of the antepenultimate is, with a little regard to true quantity, pronounced long, as in *maneo*, *redeat*, *odium*, *imperium*. Quantity is, however, vitiated, to make *i* short, even in this case, as in *oblivio*, *vinea*, *virium*. The only difference we make in pronunciation between *vinea* and *venia*, is, that to the vowel of the first syllable of the former, which ought to be long, we give a short sound; to that of the latter, which ought to be short, we give the same sound, but lengthened. *U*, accented, is always, before a single consonant, pronounced long, as in *humerus*, *fugiens*. Before two consonants no vowel sound is ever made long, except that of the diphthong *au*, so that, whenever a doubled consonant occurs, the preceding syllable is short.

Mr. Pickbourn, the author of a Dissertation on the English Verb, justly observes (Monthly Magazine, No. 135), 'That scholars err in their pronunciation of, 1st, words of two syllables having the first short, as *eques*; 2dly, words of three syllables having the first long and the second short, as *sidera*; 3dly, polysyllables accented on the antepenultimate; as *juvenilibus*, *interea*, &c.; and, lastly, words ending in a long vowel, as *domini*, or in a long vowel and a single consonant, as *dominis*. These errors arise in part from the want of distinguishing between the long and short powers of the vowels, and, in part from the indistinct and confused notion which we have of accent. For, when it falls on a short syllable, we often make that syllable long; and, when it falls on a long one, we sometimes make it short. Accent does certainly affect quantity; that is, it makes the accented syllable a little longer than it would be without it. But its operation is never so great as to make a short syllable become long, nor does the privation of accent make a long syllable become short; for there are degrees of time both in long and short syllables. All short syllables are not equally short; nor are all long ones equally long.'

In justice to this part of the subject we may now offer a remark which we find in Dr. Valpy's excellent Greek Grammar. He differs in some degree from Mr. Pickbourn, when he observes, 'that the elevation of the voice does not lengthen the time of that syllable, so that accent and quantity

by the best critics are considered as perfectly distinct, and by no means inconsistent with each other. In our language the accent falls on the antepenultimate equally in the words *liberty* and *library*, yet, in the former, the tone only is elevated, in the latter the syllable is also lengthened. The same difference exists in *baron*, and *bacon*, in *lével* and *léver*. In words of two and of three short syllables the difference between the French and English pronunciation is striking. The former make iambics and anapæsts, the latter choreas and dactyls. The French say, *fugis*, *fugimús*; the English, *fugis*, *fugimus*. In many instances both are equally faulty; thus we shorten the long *is* in *fávus*, the plural of *fávus*; they lengthen the short *is* in *óris*, the genitive of *os*. Indeed both may be said to observe neither accent nor quantity.' We have thus stated at length the manner in which ancient quantity is violated by the moderns, and more particularly by the English.

Three methods present themselves to enable us to preserve the prosodial quantity. 1st. To allow every vowel its prescribed duration, without altering the customary division of syllables; as *nô-ta*, *lô-cus*, &c.; but this will oblige us to throw the accent on the second syllable, as *glô-bus*, contrary to the laconic canon of Sanctius:

'Accentum in se ipsa monosyllaba dictio ponit.  
Exacuit sedem dissyllabon omne priorem.  
Ex tribus extollit primam penultima curta.  
Extollit se ipsam quando est penultima longa.'

This will very frequently occasion the following vowel to be long; as, *té-né-o*, contrary to, 'Vocalis ante alteram in eadem dictione ubique brevis est.'

2dly. If, then, we must abandon the preceding method, we have the alternative left of uniting to the preceding vowel the succeeding consonant; as, *nôt-a*, *lôc-us*. But still some difficulty occurs, for, first, this method would in many instances occasion pronunciations very harsh to our customary prepossessions; as, *grád-us*, *cád-o*, *plíc-o*, *stüp-e-o*, *bôn-us*, *jüb-e-o*, *tén-e-o*, *mán-e-o*, *núm-e-rus*, *trib-us*, *hôn-os*, *fáv-or*, *füt-u-rus*, *jüg-um*, *fid-es*, *pét-o*, *tím-or*, *tím-e-o*, *víd-e-o*, 'Homines tuentur illum glôb-um.' 'Per-tæsum est con-jüg-ii, &c. But is this really an objection? Have not custom and long-established usage the power of warping the mind, and giving it prejudices against that which in its unbiassed state it would have adjudged to be agreeable and elegant? This from innumerable instances we are assured to be a fact. And we may very reasonably enquire, is all this harshness of pronunciation of which we appear to be so sensible actually chargeable on the ancients? Does it not arise rather from the mistaken ideas we have formed of the power of their vowels and consonants, which, if rectified, would render the harmony of pronunciation and prosodial quantity again consistent?

'E, in Latin, as well as Greek,' according to Ainsworth, 'was pronounced *æ*.' From the circumstance of their anciently writing *TEI* *ΑΓΑΘΕΙ* *ΤΥΧΕΙ* for *τη αγαθη τυχη*, it is to *η* that he attributes the power of *æ*. But since it is ambiguous, and the attempt inconclusive, to

explain the sound of one ancient vowel by another, the most satisfactory and decisive method, as far as it can be done, is to have recourse to the more immutable sounds of nature.

The learned authors of the Port Royal Greek Grammar, in order to convey the sound of the long Greek vowel  $\eta$ , tell us 'it is a sound between the  $e$  and  $a$ ; and that Eustathius, who lived towards the close of the twelfth century, says that  $\beta\eta$ ,  $\beta\eta$ , is a sound made in imitation of the bleating of a sheep; to this purpose they quote the following verse of an ancient writer, Cratinus:—

‘Οδ’ ἡλίθιος ὡσπερ τρόβατον, βῆ, βῆ, λεγων βαϊζι.ι.

‘Is fatuus perinde, ac ovis, bē, bē, dicens incedit.

‘He, like a silly sheep, goes crying baa.’

In a similar manner the sound of the long  $i$  is preserved to us by the word  $\pi\pi\iota\omicron$ , which signifies to pip like a chicken; and, since their note is nearly what we may express by pee-ep, the long power of that letter seems to have been equivocal to our  $ee$ . Eustathius likewise remarks on the 499th verse of Iliad I. that the word  $\beta\lambda\omicron\psi$  ἰστὶν ὁ τῆς κλεψύδρας ἤχος μμητικῶς κατὰ τὰς παλαιὰς βῆ ἔχει μίμησιν προβάτων φωνῆς. Κροτινος, i. e.  $\beta\lambda\omicron\psi$ , is, according to the ancients, an imitation of the sound of the clepsydra; et  $\beta\eta$  imitates the bleating of sheep. The clepsydra was an instrument to measure time by water; and, it should be particularly observed, was occasionally employed to measure time for the regulations of orators, and in other recitations. Abstracting the  $o$  in  $\beta\lambda\omicron\psi$  from the effect of position before  $\psi$ , it will, as we shall determine hereafter, have the power of our  $o$ ; and  $\beta\lambda\omicron\psi$  adequately imitates the noise of water running with intermissions out of a narrow-mouthed vessel; and, with the French pronunciation, with equal propriety, is signified by the word  $glouglou$ ; but not quite so happily by us, by the word  $guggle$ . Ainsworth seems to consider that the long sound of  $o$  was equal to  $u$ . To determine this, it may be useful to quote the word  $gl\omicron$ cio, to cluck as a hen (from  $\kappa\lambda\omega\zeta\omega$ ), particularly since this word, amongst many others will prove an irrefragable proof that  $c$ , amongst the ancients, was equivocal to  $z$ , or hard, since  $glouk$ ,  $glouk$ , is the sound produced by the hen after the period of incubation. The sound of the long  $u$  is no less sincerely preserved by Plautus in Menæch. page 622, edit. Lambin, in making use of it to imitate the cry of an owl:—

‘Men. Egon’ dedi? Pen. Tu, Tu, istic, inquam vin’ afferrī noctuam,

Que tu, tu, usque dicat tibi? nam nos jam nos defessi sumus.’

‘It appears here,’ says Mr. Forster, in his Defence of the Greek accents, page 129, that an owl’s cry was  $tu$ ,  $tu$ , to a Roman ear;  $tu$ ,  $tu$ , to a French; and  $too$ ,  $too$ , to an English one.’ Lambin, who was a Frenchman, observes on the passage, ‘Alludit ad noctuæ vocem  $tu$ ,  $tu$ , seu  $tu$ ,  $tu$ .’ On this Mr. Walker remarks, that the English have totally departed from this sound of the  $u$  in their own language, as well as their pronunciation of Latin. Ausonius confirms this power of  $u$ : ‘Cecropiis ignota sonis, feralē so-

nans U. Feralē idēn, quia refert feralē illam avem.’ This also explains the reason of the Latin word  $b\ddot{u}bulo$  expressing the cry of an owl. Aristophanes has handed down to us the pronunciation  $cf$  of the Greek diphthong  $\delta\upsilon$ ,  $\xi\upsilon$ , by making it expressive of the barking of a dog. This is what is exactly preserved by nurses and children to this day in bow, wow. This is the sound of the same letters in the Latin tongue, not only in proper names derived from Greek, but in every other word where this diphthong occurs. Most nations in Europe, perhaps all but the English, pronounce audio and laudo, as if written  $owdio$  and  $lowdo$ ; the diphthong sound like  $ou$  in loud.’

Since the long  $u$  has been so fully proved to have been equivocal to  $oo$ , which Dr. Carey confirms, by considering it equivalent to the Greek  $u$ , and to the sounds in the Italian  $pur$ , the French  $pour$ , and the English  $poor$ , we may suppose that the ancients pronounced  $lumen$ , according to our orthography,  $loomen$ , and allowed the power of the middle  $u$ , as in  $cube$ , to their short accented  $u$ , and that of  $\ddot{u}$ , as in  $cub$ , to their short unaccented  $u$ , i. e. when the accent rested on the following consonant. Hence, instead of being compelled to divide  $n\ddot{u}m$ -er-us,  $f\ddot{u}t$ -u-rus,  $st\ddot{u}p$ -e-o,  $j\ddot{u}b$ -e-o, so as to throw the accent on the latter consonant of the first syllable, we may adopt a distribution more reconcilable, at least with our habits, and by placing the accent on the first vowel instead of the following consonant, may give the short Roman accented  $u$  the sound of  $u$  in  $tube$ , and pronounce nearly as usual,  $n\ddot{u}$ -me-rus,  $f\ddot{u}$ -tu-rus,  $j\ddot{u}$ -be-o, &c. Relative to  $jugum$  and conjugium, we here avail ourselves of a remark from Dr. Carey. ‘The word, which in England we pronounce  $jugum$ , is in reality  $yugum$ , as the Germans, in fact, at this day, pronounce it. Of this, indeed, there is little doubt, since  $\text{Iak}\omega\beta$  was properly  $yak\ddot{o}b$ , and the Hebrew  $\text{י}^{\text{ו}}$ , before a vowel, had the power of  $y$ . Now by these remarks being warranted, first, to place the accent on the first vowel of the root  $j\ddot{u}$ -gum: secondly, to give the power of the middle  $u$  to the short Roman accented  $u$ ; and thirdly, that of  $y$  to  $j$  before a vowel, we may avoid nearly all the harshness for which these words would otherwise have been notorious; as  $y\ddot{u}$ -gum, con- $y\ddot{u}$ -gium. The same unpleasantness may be removed from  $gl\ddot{o}b$ -us, since the long Roman  $o$  is considered to have been equal to  $u$ , which is more exactly represented by our  $au$ ; for  $h\ddot{o}ra$  was probably pronounced  $haura$ , since it is borrowed from the Hebrew  $\text{אור}$ ,  $aur$ , and  $aur\ddot{o}ra$  from  $\epsilon\upsilon$ ,  $\text{אור}$  (propitious light), or  $owraura$ . Therefore the middle  $o$ , as in note, may be ceded to the short Roman accented  $o$ , and for  $gl\ddot{o}b$ -us, we may, more agreeably, say  $gl\ddot{o}$ -bus.

Many writers have undertaken to assign the syllables which constitute the seat of the accent, but few distinguish the accented vowel from the accented consonant. And here, perhaps, the solution of the whole may be found. It is evident, that  $m\ddot{u}$ -les has the accent on the first syllable, and on the vowel of that syllable: hence  $i$  is easily preserved long. And, it is equally obvious, that  $hon\ddot{o}rif\ddot{i}cus$  has the accent on the an

tepenultimate, and on the consonant *f* of that syllable; and, therefore, it more rapidly inclines to an increased brevity.

Another difficulty to which we are liable in our apprehension of the nature of ancient quantity arises from that which is said to be long by position. From this some have deduced an objection against the attempt to conform the present pronunciation to quantity; observing that, 'if we would be consistent and unexceptionable in our adherence to prosodial metre, we have to recollect that the same word is often both long and short; as *nĕc*, when single, or not followed by a consonant; which by position we find long, as *Fulgura nĕc diri toties arserē cometæ*. Then, if we invariably echo the quantity, we must, *pro re natā*, say *nĕc*, and *nĕc diri*, i. e. *neek*, and *neck diri*. And the improbability that the ancients were so ready on every occasion to pronounce the same word both long and short would incline us to infer that we have no idea of what they meant by quantity.'

This has given rise to the remarks in Mr. Walker's Treatise on Classical Pronunciation, which, if they are not in every instance the most decisive, are at least the most ingenious that we have seen on the question.

'The long quantity,' says he, 'of the ancients, must arise either from a prolongation of the sound of the vowel, or from the delay of the voice, which the pronunciation of two or more consonants in succession are supposed naturally to require. Now vowels were said to be either long by nature, or long by position. Those vowels which were long by position were such as were succeeded by two or more consonants; as the first *o* in sponsor. If the long quantity of the ancients was the same distinction of the sound of the vowel as we make in the words cadence and magic, then the *a* in *māter* and *pāter* must have been pronounced like our *a* in paper and matter; and those vowels which were long by position, as the *a* in *Bācchus* and *cāmpus*, must have been sounded by the ancients as we hear them in the words *bake* and *came*. But if the long quantity of the ancients was no more than a retardation of the voice on the consonants, or that duration of sound which an assemblage of consonants is supposed naturally to produce, without making any alteration in the sound of the vowel, of such long quantity as this an English ear has not the least idea. Unless the sound of the vowel be altered, we have not any conception of a long or short syllable; and the first syllables of *banish*, *banter*, and *banter*, have, to our ears, exactly the same quantity. The same may be observed of *senate*, *seminary*, *sentence*, and *sentiment*;' and if, as an ingenious enquirer into this subject has asserted, the ancients pronounce both the consonants in *callidus*, *fallo*, &c., this seems to shorten, rather than lengthen, the vowel of the first syllable. 'If, however, the quantity of the ancients lay only in the vowel, which was lengthened and shortened in our manner by altering the sound, how strange must have been their poetical language, and how different from the words taken singly! And, when these observations on the quantity of the ancients are collect-

ively considered, shall we wonder that the learned and ingenious author of the Elements of Criticism should go so far as to assert that the dactyls and spondees of hexameter verse, with respect to pronunciation, are merely ideal, not only with us, but that they were so with the ancients themselves? Few, however, will adopt an opinion which will necessarily imply that the Greek and Latin critics were utterly ignorant of the nature of their own language; and every admirer of those excellent writers will rather embrace any explanation of accent and quantity, than give up Dionysius of Halicarnassus, Cicero, Quinctilian, and Longinus. Suppose then, as a last refuge, we were to try to read a Greek or Latin verse, both by accent and quantity, and see what such a trial will produce.

'By quantity, let us suppose the vowel lengthened to express the long quantity; and by the acute accent the rising inflexion; thus:—

Tityre. tú pátula récubans súb tégmīnĕ fági,  
Sylvéstreem tĕnúi músam meditáris avéna.

Tityrĕ. tú pátula récubāns súb tégmīnĕ fági,  
Sylvéstrĕm tĕnúi músam mĕditáris avĕnā.

Teétyre too pátulee récubanes soób tégmīne fági,  
Seélvēestream tĕnúi móbsame meditáris avéna.

Μῆνιν αἰεῖδε θεῖα, Πηληϊάδεω Ἀχιλῆος  
Οὐλομένην, ἣ μυρὶ Ἀχαιοῖς ἄλγε ἔθηκεν.

Μῆνιν αἰεῖδ'ε θεῖα, Πηλῆϊάδew Ἀχιλῆος  
Οὐλόμένην, ἣ μύρι Ἀχαιούς ἀλγῆ ἐθήκεν.

Mĕn-en á-eye-de The-ây, Pei-lei-e-á-dyo A-kil-lel-ose.

Ow-lom-én-ein, heł moo-ré a-kay-oès al-ge éth-ei-kei.

'Now there are but four possible ways of pronouncing these verses, without going into a perfect song. One is, to pronounce the accented syllable with the falling inflexion, and the unaccented with the same inflexion in a lower tone; which is the manner in which we pronounce our own words, when we give them the accent with the falling inflexion. The second is to pronounce the accented syllable with the rising inflexion, and the unaccented syllables with the same inflexion in a lower tone; which we never hear in our own language. The third is to pronounce the accented syllable with the falling inflexion, and the unaccented syllables with the rising, in a lower tone. And the fourth to pronounce the accented syllable with the rising inflexion, and the unaccented with the falling, in a lower tone. None of these modes, but the first and last, do we ever hear in our own language; the second and third seem too difficult to permit us to suppose that they could be the natural current of the human voice in any language. The first leaves us no possible means of explaining the circumflex; but the last, by doing this, gives us the strongest reason to suppose that the Greek and Latin acute accent was the rising inflexion, and the grave the falling inflexion in a lower tone.'

Concerning the question whether the ancient poetry should be read chiefly according to accent or quantity, which has lately been much agitated, may we not then infer, that since the precise nature of accent does not seem to be determined,

and therefore if, in reading, either must give way to the other (for which, however, there is no absolute necessity), it is certainly better that what is in some degree uncertain should yield to that which is more accurately ascertained. By reading according to quantity is not, however, meant the breaking down, splitting, or destroying the words by attending to the feet only; but pronouncing the words of a verse so as to give, as much as possible, its due quantity, in real time, to every syllable. And as much as to this mode of reading, we can add an attention to accent, emphasis, tone, pause, and cadence, whether metrical or sentential, insomuch, doubtless, will the pronunciation be the more correct and harmonious.

The nature of quantity as observed in the English language is at once so simple, unique, and, in general, so well known, that any enlargement on this part of the subject is unnecessary. It is sufficient to observe that a vowel or syllable is, in the English language, long, and requires double the time of a short one, when the accent is on the vowel; which occasions it to be slowly joined in pronunciation with the following letters; as *fäll*, *bäle*, *höuse*, *fëature*. And that a syllable is short, and only of half the length of a long one, when the accent is on the consonant; which occasions the vowel to be quickly joined to the succeeding letters; as *ärt*, *bönnët*, *hünger*.

QUANTONG, an extensive, fertile, and populous province of Southern China, on the sea coast, which bounds it E.S.S. Northward it is bounded by a high ridge of mountains, which separate it from Kyangsi. It contains the important port of Canton, and is the most commercial of all the Chinese provinces. The mountains of the north frontier yield gold, copper, iron, and the timber called iron-wood: also a fine species of rose-wood and of osier. Southward, the country produces every kind of grain and fruits in profusion, and two crops in the year. A great number of ducks are bred in the waters. The governor resides at Chao-king, and has a considerable military and naval force on foot to suppress the piracy of the neighbouring seas, and keep in awe the rude mountain tribes. Sir George Staunton estimates the inhabitants at 21,000,000.

QUANTONG, a town of the province of Ava, in the Birman empire, on the south-east side of the Irrawaddy, and only twenty-five miles distant from the China frontier. The meaning of Quantong, or Canton, is, in Chinese, a port or mart; a number of such names, therefore, occur on the boundaries of the empire, to which foreign merchants are allowed to repair. It is probable this town was either built or named by the Chinese: it is still frequented by these merchants, who bring porcelain, tea, silks, fruit, &c., hither, and exchange them for emeralds, rubies, iron, and brown cotton.

QUARANTAIN, *n. s.* } French *quarantain*.  
 QUARANTINE. } The space of time which a ship, suspected of infection, is obliged to forbear intercourse or commerce.

Pass your *quarantine* among some of the churches round this town, where you may learn to speak, be-

fore you venture to expose your parts in a city con-  
*gregation.* *Swift.*

QUARANTINE may be ordered by the king, with advice of the privy council, at such times, and under such regulations, as he judges proper. Ships ordered on quarantine must repair to the place appointed, and must continue there during the time prescribed, generally six weeks; and must have no intercourse with the shore, except for necessary provisions, which are conveyed with every possible precaution. When the time is expired, and the goods opened and exposed to the air as directed, if there be no appearance of infection they are admitted to port. Persons giving false information to avoid performing quarantine, or refusing to go to the place appointed, or escaping, also officers appointed to see quarantine performed deserting their office, neglecting their duty, or giving a false certificate, suffer death as felons. Goods from Turkey, or the Levant, may not be landed without a licence from the king, or certificate that they have been landed and aired at some foreign port. See SANITARY LAWS.

QUARLES (Francis), the son of James Quarles, clerk to the board of green cloth, and purveyor to queen Elizabeth, was born in 1592. He was educated at Cambridge; became a member of Lincoln's Inn; and was for some time cup-bearer to the queen of Bohemia, and chronologer to the city of London. He went to Ireland as secretary to archbishop Usher; but the troubles in that kingdom forced him to return, and he died in 1644. His works both in prose and verse are numerous, and were formerly in great esteem, particularly his *Divine Emblems*.

QUARRE, *n. s.* Fr. *quarré*. A quarry. Not in use.

Behold our diamonds here, as in the *quarre* they stand. *Drayton.*

QUARREL, *n. s. & v. n.* } Fr. *querelle*;  
 QUARRELOUS, *adi* } Lat. *querela*. A  
 QUARRELSOME. } breach of concord; dispute; contest; cause of contest; ground of opposition or objection: Shakespeare uses it for a quarrelsome person: to quarrel is, to dispute; debate, squabble; scuffle; combat; disagree; object, urge frivolous objections: the adjectives correspond.

Herodias had a *quarrel* against him, and would have killed him, but she could not. *Mark vi. 19.*

Wine drunken with excess, maketh bitterness of the mind, with brawling and *quarrelling*. *Ecclesi.*

He thought he had a good *quarrel* to attack him. *Holinghed.*

The *quarrel* which, in this present part, striveth against the current and stream of laws, was a long while nothing feared. *Hooker.*

I love the sport well, but I shall as soon *quarrel* at it as any man. *Shakespeare.*

If I can fasten but one cup upon him, With that which he hath drank to night already, He'll be as full of *quarrel* and offence As my young mistress' dog. *Id. Othello.*

Better She ne'er had known pomp, though t' be temporal; Yet if that *quarrel*, fortune, do divorce It from the bearer, 'tis a suff'rance panging As soul and body's sev'ring. *Id. Henry VIII.*

Ready in gybes, quick answered, saucy, and  
As quarrelous as the weazel. *Id. Cymbeline.*

Wives are young men's mistresses, companions  
for middle age, and old men's nurses; so a man  
may have a quarrel to marry when he will. *Bacon.*

Cholerick and quarrelsome persons will engage one  
into their quarrels. *Id. Essays.*

If not in service of our God we fought,  
In meane quarrel if this sword were shaken,

Well might thou gather in the gentle thought,  
So fair a princess should not be forsaken. *Fairfax.*

You and I may engage in this question, as far as  
either of us shall think profitable, without any the  
least beginning of a quarrel, and then that will com-  
petently be removed from such, as of which you  
cannot hope to see an end. *Hammond.*

It were a matter of more trouble than necessity to  
repeat in this quarrel what has been alledged by the  
worthies of our church. *Holyday.*

To admit the thing, and quarrel about the name,  
is to make ourselves ridiculous.

Some things arise of strange and quarreling kind,  
The forepart lion and a snake behind. *Cowley.*

In a poem elegantly writ  
I will not quarrel with a slight mistake.

Beasts called sociable quarrel in hunger and lust;  
and the bull and ram appear then as much in fury  
and war, as the lion and the bear. *Temple.*

I quarrel not with the word, because used by Ovid.  
*Dryden.*

The same zeal and faithfulness continues in your  
blood, which animated one of your noble ancestors  
to sacrifice his life in the quarrel of his sovereign.

We are apt to pick quarrels with the world for  
every little foolery. *L'Estrange.*

There needs no more to the setting of the whole  
world in a flame than a quarrelsome plaintiff and  
defendant. *Id.*

I have no quarrel to the practice; it may be a di-  
verting way. *Felton on the Classics.*

I consider your very testy and quarrelsome people  
in the same light as I do a loaded gun, which may  
by accident go off and kill one. *Shenstone.*

QUARREL. *Fr. quadreau; Ital. quadrella,*  
of *Lat. quadrangula.* An arrow with a square  
head.

It is reported by William Brito that the arcuba-  
lista or arbalist was first skewed to the French by  
our king Richard I. who was shortly after slain by  
a quarrel thereof. *Camden.*

Twanged the string, out flew the quarrel long.  
*Fairfax.*

QUARRY, *n. s.* } *Fr. quarrè,* of *Lat. qua-*  
QUARRYMAN. } *dratus.* A square; an ar-  
row with a square head; a place where stones  
are roughly squared: a quarryman is one who  
works in a quarry.

The same is said of stone out of the quarry, to  
make it more durable. *Bacon's Natural History.*

The shafts and quarries from their engines fly,  
As thick as falling drops in April showers.

As hard and unrelenting she,  
As the new-crusted Niobe;

Or, what doth more of statue carry,  
A nun of the Platonick quarry. *Cleveland.*

Pyramids and towers  
From diamond quarries hewn, and rocks of gold.

He like Amphion makes those quarries leap  
into fair figures from a confused heap. *Waller.*

Could necessity infallibly produce quarries of stone,  
which are the materials of all magnificent structures!

For them alone the heavens had kindly heat  
In eastern quarries, ripening precious dew.

To take down a quarry of glass to scowre, sodder,  
band, and to set it up again, is three halpence a  
foot.

As long as the next coal-pit, quarry, or chalk-pit  
will give abundant attestation to what I write, to  
these I may safely appeal.

One rhomboidal bony scale of the needle-fish, out  
of Stunsfield quarry, the quarryman assured me was  
flat, covered over with scales, and three foot long.

QUARRY, *n. s. & v. a.* *Fr. querir,* to seek.  
Skinner. *Fr. curée,* from *Lat. curo.* Thomson.  
A prey; particularly the prey of the hawk: to  
prey upon.

She dwells among the rocks, on every side  
With broken mountains strongly fortified;

From thence whatever can be seen surveys,  
And stooping, on the slaughtered quarry preys.

Your wife and babes  
Savagely slaughtered; to relate the manner,  
Were on the quarry of these murdered deer  
To add the death of you.

So scented the grim feature, and up turned  
His nostrils wide into the murky air,  
Sagacious of his quarry.

They their guns discharge;  
This heard some ships of ours, though out of view,  
And swift as eagles to the quarry flew.

An hollow crystal pyramid he takes,  
In firmamental waters dipt above,  
Of it a broad extinguisher he makes,  
And hoods the flames that to their quarry strove.

Let reason then at her own quarry fly,  
But how can finite grasp infinity?

With cares and horrors at his heart, like the vulture  
that is day and night quarrying upon Prometheus's  
liver.

QUARRY, among hunters, is sometimes used  
for a part of the entrails of the beast taken, given  
by way of reward to the hounds.

QUARRY, or QUARREL, among glaziers, a pane  
of glass cut in a diamond form. Quarries are of  
two kinds, square and long; the acute angle in  
the square quarrels being 77° 19', and 67° 21' in  
the long ones.

QUARRYING, is the business of directing  
and conducting the sinking and management of  
the different kinds of quarries, pits, and shafts,  
as well as of the different sorts of work which  
are necessary to be undertaken, carried on, and  
performed in the several different descriptions of  
them; such as those of separating, getting up,  
and preparing the various sorts of materials for  
use in the arts, or in other ways. It is a practice  
which requires considerable knowledge and ex-  
perience, to be fully master of it in all its bear-  
ings and intentions.

Limestone, chalk, and building stone, are gene-  
rally found in strata either on or near the surface.  
When at a great depth it is not found worth while  
to work them. When stones of any kind are pro-  
cured by uncovering the earth, and then working  
them out, they are said to be quarried; but when



a pit or shaft is sunk, and the materials procured are worked under ground, they are said to be mined.

*Quarrying slates*, particularly those of the blue, green, and purple or blackish kinds, undergo several different sorts of preparation in the quarrying, according to the purposes to which they are to be afterwards applied. They are separated and divided into very thin pieces or slates, where light neat coverings are required, or in much demand; but for more strong and heavy coverings, in exposed situations, or other places, they are split into much thicker sheets, layers, or slates, and are, of course, more clumsy in their appearance. Each sort in the business of quarrying is wrought in a separate manner, and packed up by itself; the different sorts having appropriate names.

White or brown slates are never divided and prepared in so fine a way as the other kinds, but separated into much thicker flakes or laminæ, in this intention. The blue, green, and purple, or darkish sorts, are, for the most part, found capable of being split into very thin laminæ or sheets; but those of the white, or brownish free-stone kinds, can seldom be separated or divided in any very thin manner, as the layers of the large masses of the stones are of a much thicker nature, they consequently form heavy, strong, thick coverings, proper for buildings in exposed climates and situations, and of the more rough kinds, such as barns, stables, and other sorts of out-houses. In the different operations and processes of this sort of quarrying, slate knives, axes, bars, and wedges, are chiefly made use of in the different intentions of splitting and cleaning the slates, they being separated into proper thicknesses by the axe, bar, and wedge, and afterwards chipped into their proper forms and shapes by the knife. All the different inequalities which may appear upon any part of them are likewise removed by this last sort of implement.

In *quarrying stone* the work is usually performed in such a manner as to suit the different uses for which they are intended. Where flags are to be formed, they are split or riven into suitable thicknesses, and squared to different sizes, so as to be adapted to different applications. These operations are executed in rather a rough way, as they are afterwards to be finished by the stone-mason. When for steps they have the proper breadths and depths given to them in a sort of squaring manner, being left to be completed as they may be wanted for particular uses and applications. Gate-posts are, for the most part, quarried so as have from about a foot to a foot and a half or more in the square. Trough-stones have the quarrying performed so as to be formed into various proper-sized squares or other forms, in a rough manner, being left in these states to be afterwards hewn and hollowed out, in the intended parts, by the stone-masons. Stones for building purposes are usually raised and quarried out roughly into something of the square shape, being left in that state for the builders, who afterwards fit them so as to suit their own purposes and intentions.

The quarrymen commonly make use of large

hammers, with cutting ends on one side, the other being formed in a plain manner; strong sharp crowbars, and broad sharp iron wedges; by which means these matters are, from the constant practice of the men, split and torn into such forms as are wanted with great ease and facility.

*Quarry Cart* is a name given to that sort of cart which is principally employed in the work of quarries, and which is generally of a low, compact, strong kind, in its nature, form, and manner of construction, in order to sustain heavy weights, and receive them without difficulty, or the danger of being destroyed. Carts for this purpose should always be made of well-seasoned wood, be well put together, and have sufficient strength of timber in those parts where the main stress of the load is placed. Some quarry counties have well-formed carts of this nature, as many of those towards the northern boundaries of this kingdom.

*Quarry Waggon*, or truck, a small carriage of the low truck kind, which is much employed in the business of quarries, especially those of the slate kinds, for the purpose of holding and conveying the rough materials, which have been blown from the large massy rocks, or separated in other ways, out of or from the quarries and pits in which they are situated and contained, to the places where they are to receive their different preparations and shapes.

It is formed and constructed on a frame somewhat similar to that of the common barrow, and mounted on two low light iron wheels on the fore part, having two feet behind, projecting from the frame, bent something in the manner of the letter S, and of sufficient length to let it stand or rest in a horizontal position while it is in the act of being loaded. These feet are usually made of iron, but they may be formed of other materials. A sort of inclined plane is formed from the bottoms of the quarries or pits, up which it is forced with great ease and facility by the workmen, or small animals of the horse kind, after being filled with these sorts of heavy materials. It is a very useful and convenient machine in this application, being met with in most of the slate quarries in the northern part of Lancashire, as well as in those of many other districts of the kingdom.

*Quarryings* are the small pieces which are broken or chipped off from the different sorts of materials which are found and wrought in quarries, while they are undergoing their different preparations for various uses. These substances, where they are of the hard kind, such as those of the blue and lime-stone, as well as some other sorts, are extremely well calculated for the purpose of forming and repairing roads, as they are nearly, if not quite, in a state fit for immediate application in this way. Materials of these kinds ought, therefore, where they can be conveniently had, never to be neglected by those who have the care and management of roads, as they will save much expense and trouble, in a great number of instances.

*Draining of quarries.*—In order to accomplish this it will be necessary, in ascending from the quarry or pit, carefully to examine and ascertain

if, at any place higher on the declivity, any porous stratum, bed of rock, sand, or gravel, tails out, which may conduct and convey the water contained in it to the sand bed, which is below in the works; and, where any such bed is found, to cut or bore into it in such a manner as to form a drain that is capable of carrying away the whole or the greatest part of the water, and of course to clear or diminish the quantity contained in the quarry or pit, which would otherwise have continued to descend through such porous substrata or beds, and have continued to fill the sands, or quarries and pits.

But a sufficient quantity to injure, hinder, and inconvenience the working of the quarries or pits, may yet continue to drain and ooze from the sides of the sand-beds, notwithstanding they should happen to dip towards the lower ground, in which case, however, the water may readily and with great ease be drawn off at some particular point in it. In order to effect this, and thereby remove the inconvenience of this filtrating water, in descending from the quarries or pits along the declivity, it should be endeavoured to discover and ascertain at what particular point or place, in the low ground, the sand terminates or tails out, which is mostly best accomplished by means of proper levelling; and if there should be there any appearance of the water's having a natural outlet, it may, by means of making in it a deep drain, be far more readily and effectually drawn off and removed; as springs, for the most part, naturally pass and flow through narrow, winding, convoluted openings, or perforations; of course, whenever the orifices or passages are opened, enlarged, or made lower than before, the discharge of water becomes greater and more expeditious. Where, however, there happens to be a deep impervious layer or covering of clay, or other matter of a similar nature, placed above or upon the termination or tail of the sand, the drain need only be cut down to it or a little way into it, as by means of boring through it, or the remaining portion of it, a ready and easy outlet or passage may be given to the whole of the water that may be contained in the sand-bed or other porous stratum.

In regard to the removal of the water found and contained in the bottoms of such quarries, pits, or deep works, it must be drained off and got rid of in quite a different manner, as the level of the ground may probably be, or decline, nowhere lower than the mouths or openings of such quarries, pits, &c.; as it is solely and particularly on the supposition, and in such cases as where the direction of the different strata and sand-beds have a dipping position with the natural inclination of the surface of the land, or lie nearly horizontally, that the method of proceeding which is stated above is practicable. But should they, for instance, lie in a reverse or contrary direction, there is but little possibility or chance of accomplishing the object, the removal of the water, unless by discovering or hitting on their terminations, somewhere on the opposite sides of the hills or elevations, which in some cases may very nearly or exactly be found out, by ascertaining the precise inclination or direction of the materials of the quarries, pits, &c.,

and by a careful and exact use of the level. But this will be much better comprehended, and a more full and perfect notion of its nature be afforded, by the section figure in the plate on draining quarries, pits, &c., in agriculture, given by Mr. Elkington, in his work on this subject.

The water which is found in the bottoms of these different kinds of undertakings, or which proceeds from the rocks or their sides, or in other ways in the course of working them, is commonly got quit of by means of some sort of engine or pump, in order to assist in working of which the water gained by cutting the drains already noticed may be particularly useful, especially where the usual stream for that purpose is insufficient for that purpose, in saving the great expense of working such machinery by the power of steam. But without the aid of a natural stream, which is capable of being converted to this purpose, it is rarely possible to find, by means of drains, or in any other way, a quantity of water sufficient to drive weighty machinery, in a situation of proper height to have the full and necessary command of it.

It has been remarked in Mr. Elkington's work on draining, in these cases, that the duke of Buccleugh's coal-works, near Langholm, in the county of Dumfries, afford a striking example of the superior powers of water and machinery, when properly combined, where a command of the former can be had, and when the latter is constructed on proper principles, and conducted with that care and ingenuity which are requisite in such difficult undertakings.

Boring has been practised of late, with complete success, in the case of a colliery in the county of York, which had been wrought many years, and in which the water was raised about sixty yards by a steam-engine.

The actual working of quarries is an operation depending more on strength than skill. In quarrying sandstone, consisting of regular layers, the work is performed chiefly by means of the pick, wedge, hammer, and pinch or lever; recourse being seldom had to the more violent and irregular effects of gunpowder. But for some kinds of limestone, and for greenstone and basalt, blasting with gunpowder is resorted to; and some of the rocks called primitive, such as granite, gneiss, and sienite, could scarcely be torn asunder without it.

The burning of lime may be considered as belonging to the subject of quarrying. See our article LIME. The operation is performed in what are called draw-kilns, or perpetual kilns. These should always be close to or near the quarry, and either situated at a bank, or furnished with a ramp or inclined plane of earth for carting up the coal and lime to the top of the kiln. Lime-kilns may be built either of stone or brick; but the latter, as being better adapted to stand excessive degrees of heat, is considered as preferable. The outside form of such kilns is sometimes cylindrical, but more generally square. The inside should be formed in the shape of a hogshead, or an egg, opened a little at both ends, and set on the smallest; being small in circumference at the bottom, gradually wider towards the middle, and then contracting again towards

the top. In kilns constructed in this way, it is observed, fewer coals are necessary, in consequence of the great degree of reverberation created, above that which takes place in kilns formed in the shape of a sugar loaf reversed. Near the bottom, in large kilns, two or more apertures are made: these are small at the inside of the kiln, but are sloped wider, both at the sides and the top, as they extend towards the outside of the building. The uses of these apertures are for admitting the air necessary for supplying the fire, and also permitting the laborers to approach with a drag and shovel to draw out the calcined lime. From the bottom of the kiln within, in some cases, a small building called a horse is raised in the form of a wedge, and so constructed as to accelerate the operation of drawing out the burned limestone, by forcing it to fall into the apertures which have been mentioned above. In other kilns of this kind, in place of this building there is an iron grate near the bottom, which comes close to the inside wall, except at the apertures where the lime is drawn out. When the kiln is to be filled, a parcel of furze or faggots is laid at the bottom, over this a layer of coals, then a layer of limestone (which is previously broken into pieces, about the size of a man's fist), and so on alternately, ending with a layer of coals, which is sometimes, though seldom, covered with sods or turf, in order to keep the heat as intense as possible. The fire is then lighted in the apertures; and when the limestone towards the bottom is completely calcined, the fuel being considerably exhausted, the limestone at the top subsides. The laborers then put in an addition of limestone and coal at the top, and draw out at bottom as much as they find thoroughly burned; and thus go on, till any quantity required be calcined. When limestone is burned with coals, from two bushels and a half to three and a half, on a medium three bushels of calcined limestone, are produced for every bushel of coal used.

A lime-kiln, on an improved plan, has been erected at Closeburn in Dumfriesshire, by Monteith. Instead of the wide and shallow circular kiln, these kilns are elliptical and deep. Some parts are added to it which are found of most important use. The first is a kind of roof or cover. The disadvantage of the want of some contrivance to protect kilns in stormy weather, has been long felt, and many attempts have been made to apply some kind of cover, but, we believe, none with such success as that used at Closeburn. The next addition is having cast-iron doors below, at the opening where the kiln is drawn. There is a grating through which the ashes fall while drawing the kiln, which makes that operation a much less disagreeable employment than formerly; and the ashes and small lime thus separated are excellent for agricultural purposes. There is often a great loss of fuel, from allowing lime-kilns to cool when there is no demand; all that is necessary to be done is, to shut the cast-iron doors, above as well as below, and the dampers in the chimneys. The heat is thus preserved, and fuel saved, by keeping the kiln hot, to be ready for use as soon as wanted. Farmer's Magazine, vol. xvi. p. 134.

Booker's lime kiln (Dumfries Report, p. 594), is of an oval form, twenty-two feet high, two feet wide at the bottom, nine feet in the middle, and gradually contracted to three feet at top. It is lined with brick, and, instead of being covered with a dome, Booker adopts a cover of cast-iron with a vent in it, which cover is placed on a ring of three feet diameter, built into, and fixed on the top of the kiln. The cover, by moving on a pivot, is easily thrown off when the kiln is to be charged, and, being put on during the process of calcination, it both increases the draught of air through the kiln, and, by acting as a reverberatory furnace, is attended with a considerable saving of fuel.

QUART, *n. s.* Fr. *quart*, of Lat. *quartus*. The fourth part; a quarter; the fourth part of a gallon; a quart measure.

Albanact had all the northern part,  
Which of himself Albania he did call,  
And Camber did possess the western *quart*.

*Spenser.*

When I have been dry, and bravely marching, it  
hath served me instead of a *quart* pot to drink in.

*Shakespeare.*

You'd rail upon the hostess of the house,  
And say you would present her at the leet,  
Because she bought stone jugs and no sealed *quarts*.

*Id.*

You have made an order that ale should be sold  
at three halfpence a *quart*. *Swiss's Miscellanies.*

QUART, in English measure, the fourth part of the gallon, or two pints.

QUARTAN, *n. s.* Fr. *quartaine*; Lat. *quartana*. The fourth day ague.

Call her the metaphysics of her sex,  
And say she tortures wits, as *quartans* vex  
Physicians. *Cleaveland.*

It were an uncomfortable receipt for a *quartan*  
ague, to lay the fourth book of Homer's Iliads under  
one's head. *Brorue.*

A look so pale no *quartan* ever gave,  
Thy dwindled legs seem crawling to the grave.

*Dryden.*

QUARTATION, *n. s.* Lat. *quartus*. A chymical operation, defined below.

In *quartation*, which refiners employ to purify gold, although three parts of silver be so exquisitely mingled by fusion with a fourth part of gold, whence the operation is denominated, that the resulting mass acquires several new qualities; yet, if you cast this mixture into aqua fortis, the silver will be dissolved in the menstruum, and the gold, like a dark powder, will fall to the bottom. *Boyle.*

QUARTATION is an operation by which the quantity of one thing is made equal to a fourth part of the quantity of another thing. Thus, when gold alloyed with silver is to be parted, we are obliged to facilitate the action of the aquafortis by reducing the quantity of the former of these metals to one-fourth part of the whole mass; which is done by sufficiently increasing the quantity of the silver, if it be necessary. This operation is called *quartation*, and is preparatory to the parting; and even many authors extend this name to the operation of parting. See ASSAY.

QUARTER, <i>n. s. &amp; v. a.</i>	} Fr. <i>quartier</i> , of Lat. <i>quartus</i> . A fourth part; a part of the heavens con- sidered as divided into the cardinal
QUARTERAGE,	
QUARTER-DAY,	
QUARTER-DECK,	
QUARTERLY, <i>adj. &amp; adv.</i>	
QUARTER-MASTER, <i>n. s.</i>	

points: hence, region; district; division; station; abode: particularly military station, cantonment, or abode; hence a military cry for mercy, i. e. to be sent to the captors' quarters; mercy; friendship; kind treatment; a measure of eight bushels: to divide into four parts; divide in any way; station; lodge; diet; bear as an appendage to herald in arms, see below: quarterage is a quarterly allowance: quarter-day, one of the four days in the year on which rent is usually paid: quarter-deck, the short upper deck of a ship: quarterly, containing a fourth part; or once in a quarter: quarter-master, he who regulates soldiers' quarters.

No leaven shall be seen in thy quarters. *Exodus.*

It is an accustomed action with her to seem thus washing her hands; I have known her continue in this a quarter of an hour. *Shakspeare. Macbeth.*

I'll give thee a wind.

—I myself have all the other,

And the very points they blow,

And all the quarters that they know,

I' the shipman's card. *Id.*

Where is lord Stanley quartered?

—Unless I have mista'en his quarters much,

His regiment lies half a mile

South from the mighty power of the king.

*Shakspeare.*

Friends, all but now,

In quarter, and in terms like bride and groom

Divesting them for bed, and then, but now

Swords out, and tilting one at other's breasts. *Id.*

Mothers shall but smile when they behold

Their infants quartered by the hands of war. *Id.*

They do best, who, if they can but admit love, yet make it keep quarter, and sever it wholly from their serious affairs. *Bacon.*

The first, being compounded of argent and azure, is the coat of Beauchamp of Hack in the county of Somerset, now quartered by the earl of Hertford.

*Penham.*

The like is to be said of the populousness of their coasts and quarters there. *Abbot.*

They had settled here many ages since, and overspread all the parts and quarters of this spacious continent. *Heylin.*

The soil so fruitful that an acre of land well ordered will return 200 bushels or 25 quarters of corn. *Id.*

Thou canst defend as well as get,  
And never hadst one quarter beat up yet. *Cowley.*

He magnified his own clemency, now they were at his mercy, to offer them quarter for their lives if they gave up the castle. *Clarendon.*

His praise, ye winds! that from four quarters blow,  
Breathe soft or loud. *Milton's Paradise Lost.*

He fed on vermin;

And, when these failed, he'd suck his claws,

And quarter himself upon his paws. *Hudibras.*

He used two equal ways of gaining,

By hindring justice or maintaining;

To many a whore gave privilege,

And whipped for want of quarterage. *Id.*

However rarely his own rent-dayes occurred, the indigent had two and fifty quarter-dayes returning in his year. *Fell.*

The moon makes four quarterly seasons within her little year or month of consecution. *Holder.*

Observe what stars arise or disappear,

And the four quarters of the rolling year.

*Dryden.*

The quarters of the several chiefs they showed,  
Here Phenix, here Achilles, made abode. *Id.*

Discover the opinion of your enemies, which is commonly the truest; for they will give you no quarter, and allow nothing to complaisance. *Id.*

A bungling cobbler, that was ready to starve at his own trade, changes his quarter, and sets up for a doctor. *L'Estrange.*

When the cocks and lambs lie at the mercy of cats and wolves, they must never expect better quarter. *Id.*

Supposing only three millions to be paid, 'tis evident that to do this out of commodities, they must, to the consumer, be raised a quarter in their price; so that every thing, to him that uses it, must be a quarter dearer. *Locke.*

The quartermaster general was marking the ground for the encampment of the covering army. *Tutler.*

The sons of the church being so much dispersed, though without being driven, into all quarters of the land, there was some extraordinary design of divine wisdom in it. *Sprat.*

You have quartered all the foul language upon me that could be raked out of Billingsgate. *Spectator.*

When the winds in southern quarters rise,  
Ships, from their anchors torn, become their sport,  
And sudden tempests rage within the port.

*Addison.*

The usurer would be very well satisfied to have all the time annihilated that lies between the present moment and next quarter-day. *Id.*

Suppose the common depth of the sea, taking one place with another, to be about a quarter of a mile.

*Burnet.*

To the young, if you give any tolerable quarter, you indulge them in their idleness, and ruin them.

*Collier.*

From the obliquity of the ecliptick to the equator arise the diurnal differences of the sun's right ascension, which finish their variations in each quadrant of the ecliptick, and this, being added to the former inequality from eccentricity, makes these quarterly and seemingly irregular inequalities of natural days.

*Bentley.*

Mr. Wharton, who detected some hundreds of the bishop's mistakes, meets with very ill quarter from his lordship. *Swift.*

The quarter-deck is that above the upper-deck, reaching forward from the stern to the gangway, and supports the carronades, &c. *Falconer.*

QUARTER, in dry measure, is, eight bushels.

QUARTER, in heraldry, is applied to the parts or members of the first division of a coat that is quartered, or divided into four quarters.

QUARTER, FRANC, in heraldry, is a quarter single or alone; which is to possess one fourth part of the field. It makes one of the honorable ordinaries of a coat. See HERALDRY.

QUARTERS, WINTER, sometimes mean the space of time included between leaving the camp and taking the field; but more properly the places where the troops are quartered during the winter. The first business, after the army is in winter quarters, is to form the chain of troops to cover the quarters well; which is done either behind a river, under cover of a range of strong posts, or under the protection of fortified towns. Hussars are very useful on this service. It should be observed, as an invariable maxim, in winter quarters, that the regiments be disposed in brigades, to be always under the eye of a general officer; and, if possible, let the regiments

be so distributed as to be each under the command of its own chief.

**QUARTER BILL**, a roll or list, containing the different stations to which all the officers and crew of the ship are quartered in the time of battle, and the names of all the persons appointed to those stations.

**QUARTER OF A SHIP**, that part of the ship's side which lies towards the stern: or which is comprehended between the aftmost end of the main chains and the sides of the stern, where it is terminated by the quarter pieces. On the quarter may be defined an arch of the horizon, contained between the line prolonged from the ship's stern and any distant object, as land, ships, &c. Thus, if the ship's keel lies on an east and west line, the stern being westward, any distant object perceived on the north-west or south-west is said to be on the larboard starboard quarter.

**QUARTERS**, a name given at sea to the several stations where the officers and crew of a ship of war are posted in action. The number of men appointed to manage the artillery is always in proportion to the nature of the guns, and the number and condition of the ship's crew. The lieutenants are usually stationed to command the different batteries, and direct their efforts against the enemy. The master superintends the movements of the ship, and whatever relates to the sails. The boatswain, and a sufficient number of men, are stationed to repair the damaged rigging; and the gunner and carpenter wherever necessary, according to their respective offices. The marines are generally quartered on the poop and fore-castle, or gangway, under the direction of their officers; although, on some occasions, they assist at the great guns, particularly in distant cannonading.

**QUARTERS, HEAD, OF AN ARMY**, the place where the commander-in-chief has his quarters. The quarters of generals of horse are, if possible, in villages behind the right and left wings, and the generals of foot are often in the same place; but the commander-in-chief should be near the centre of the army.

**QUARTER GUNNER**, a petty officer under the direction of the gunner of a ship of war, whom he is to assist in every branch of his duty; as keeping the guns and their carriages in proper order, and duly furnished with whatever is necessary; filling the powder into cartridges; scaling the guns, and keeping them always in a condition for service. The number of quarter-gunners in any ship is always in proportion to the number of her artillery, one quarter-gunner being allowed to every four guns.

**A QUARTER MASTER**, in the army, is an officer, whose business is not only to look after the quarters of the soldiers, but their clothing, bread, ammunition, firing, &c. Every regiment of foot and artillery has a quarter-master, and every troop of horse one.

**QUARTER MASTERS**, in a ship of war, are petty officers appointed by the captain to assist in the several duties of the ship, as stowing the ballast and provisions in the hold, coiling the cables on their platforms, overlooking the steering of the ship, keeping the time by the watch-

glasses, and, in turn, overlooking the purser's steward in his delivery of provisions, &c.

**QUARTER MASTER GENERAL** is a considerable officer in the army; and should be a man of great judgment and experience, and well skilled in geography. His duty is to make the marches and encampments of an army; he should know the country perfectly, with its rivers, plains, marshes, woods, mountains, defiles, passages, &c. even to the smallest brook. Prior to a march, he receives the order and route from the commanding general, and appoints a place for the quarter-masters of the army to meet him next morning, with whom he marches to the next camp; where, having viewed the ground, he marks out to the regimental quarter-masters the ground allowed each regiment for their camp: he chooses the head quarters, and appoints the villages for the generals of the army's quarters: he appoints a proper place for the encampment of the train of artillery: he conducts foraging parties, as likewise the troops to cover them against assaults, and has a share in regulating the winter-quarters and cantonments.

**QUARTER NETTING**, a sort of net-work, extended along the rails on the upper part of a ship's quarter. In a ship of war these are always double. The interval is sometimes filled with cork, or old sails; but chiefly with the hammocks of the sailors, so as to form a parapet against the enemy's small arms in battle.

**QUARTER SESSIONS**, a general court held quarterly by the justices of peace of each county. This court is appointed by statute 2 Hen. V. c. 4, to be in the first week after Michaelmas day; the first week after the Epiphany; the first week after the close of Easter; and in the week after the translation of St. Thomas a Becket, or the 7th of July. This court is held before two or more justices of the peace, one of whom must be of the quorum. The jurisdiction of this court, by 34 Edw. III. c. 1, extends to the trying and determining of all felonies and trespasses whatsoever, though they seldom, if ever, try any greater offence than small felonies within the benefit of clergy, their commission providing, that if any case of difficulty arises, they shall not proceed to judgment, but in the presence of one of the justices of the courts of king's bench or common pleas, or one of the judges of assize. But there are many offences, and particular matters, which by particular statutes belong properly to this jurisdiction, as the smaller misdemeanors not amounting to felony, relating to the game, highways, alehouses, bastard children, the settlement and provision for the poor, vagrants, servants' wages, apprentices, &c. The records or rolls of the sessions are committed to the custody of a special officer, denominated the *custos rotulorum*. In most corporation towns there are quarter-sessions kept before justices of their own, within their respective limits, which have exactly the same authority as the general quarter-sessions of the county, except in a very few instances.

**QUARTER-STAFF**, *n. s.* Quarter and staff. A staff of defence: so called, perhaps, from one manner of using it; one hand being placed at the middle, and the other equaily between the

middle and the end. So says Dr. Johnson: Mr. Thomson, more probably, from quarter, a district, and staff; the quarterstaff being once a badge of authority amongst foresters.

His *quarterstaff*, which he could ne'er forsake,  
Hung half before, and half behind his back.

*Dryden.*

Immense riches he squandered away at *quarterstaff* and cudgel play, in which he challenged all the country.

*Arbutnot.*

**QUARTILE**, *n. s.* Lat. *quartus*. An aspect of the planets, when they are three signs or ninety degrees distant from each other, and is marked thus ☐.

Mars and Venus in a *quartile* move

My pangs of jealousy for Ariet's love. *Dryden.*

**QUARTO**, *n. s.* Lat. *quartus*. A book in which every sheet, being twice doubled, makes four leaves.

Our fathers had a just value for regularity and systems; then folios and *quartos* were the fashionable sizes, as volumes in octavo are now. *Watts.*

**QUARTO-DECIMANI**, an ancient sect in the Christian church, who taught that Easter should always be celebrated according to the custom of the Jews, on the fourteen day of the moon in the month of March, whensoever that day fell out. And hence they derived their name *quarto-decimani*.

**QUARTZ**, in mineralogy, a genus of siliceous earths, chiefly composed of silica. According to Kirwan, the quartz are in general the purest of the siliceous kind. Cronstedt gives the following characteristics of it:—1. It is generally cracked throughout, even in the rock itself, whereby, as well as by its own nature, it breaks into irregular and sharp fragments. 2. It cannot be easily made red hot, without cracking still more. 3. It never decays in the air. 4. Melted with potass, in a due proportion, it gives a more solid glass than any of the other siliceous stones. It is met with in clefts, fissures, and small veins in rocks; it seldom forms large veins, and still more rarely whole mountains, without a mixture of heterogeneous substances. M. Magellan remarks that quartz is one of the principal kinds of stone which contain metals. In some of the Hungarian veins the gold is so minutely dispersed that it cannot be discerned by the best microscopes before it is separated by pounding and washing. The width of the veins, some of which are half a fathom, and some still more, repay the trouble and expenses, which the small quantity of gold would not otherwise counterbalance. Near Lauterberg, upon the Hartz, are veins of this stone from one to three fathoms wide, consisting of a loose sand, in which they find the copper ore in nests.

Rock crystals are generally found upon or among quartz, and are to be met with in all parts of the world. The greatest numbers are furnished to the European countries from Mount St. Gothard, in Switzerland.

Professor Jameson divides this mineral genus into two species: rhomboidal quartz, and indivisible quartz.

1. Rhomboidal quartz contains fourteen subspecies. 1. Amethyst. 2. Rock crystal. 3. Milk quartz. 4. Common quartz. 5. Prase.

6. Cat's eye. 7. Fibrous quartz. 8. Iron flint. 9. Hornstone. 10. Flinty slate. 11. Flint. 12. Calcedony. 13. Heliotrope. 14. Jasper.

2. Indivisible quartz contains nine subspecies. 1. Float-stone. 2. Quartz sinter. 3. Hyalite. 4. Opal. 5. Menilite. 6. Obsidian. 7. Pitchstone. 8. Pearlstone. 9. Pumice-stone. See MINERALOGY.

**QUASH**, *v. a. & v. n.* French *casser*; Belg. *quassen*; Ital. *squacciare*, *quassare*; Lat. *quasso*. To crush; squeeze; subdue; annul; make void.

'Twas not the spawn of such as these  
That dyed with Punick blood the conquered seas  
And quashed the stern *A'acides*. *Ruocmmnon.*

The whales

Against sharp rocks, like reeling vessels quashed,  
Though huge as mountains, are in pieces dashed.

*Waller.*

A thin and fine membrane strait and closely adhering to keep it from *quashing* and shaking. *Ray.*

Our she confederates keep pace with us in *quashing* the rebellion, which had begun to spread itself among part of the fair sex. *Addison's Freeholder.*

The water in this dropsy, by a sudden jerk, may be heard to *quash*. *Sharp's Surgerj.*

**QUASI CONTRACT**, in the civil law, an act without the strict form of a contract, but yet having the force thereof. In a contract there must be the mutual consent of both parties, but in a quasi-contract one party may be bound or obligated to the other, without having given his consent to the act whereby he is obliged. For example: I have done your business, in your absence, without your procurement, and it has succeeded to your advantage. I have then an action against you for the recovery of what I have disbursed, and you an action against me to make me give an account of my administration, which amounts to a quasi contract.

**QUASSIA**, in botany, a genus of the monogynia order, and *decandria* class of plants; natural order *fourteenth*, *gruinales*. It was so named from Quassi, a negro slave, who discovered its virtues: *cal. pentaphyllous*; petals five; nectarium, *pentaphyllous*; there are from two to five seed cases, standing asunder, and monospermous. There are three species, the *amara*, *simaruba*, and *excelsa* or *polygama*.

1. *Q. amara* grows to the height of several feet, and sends off many strong branches. The wood is of a white color and light; the bark is thin and gray: the leaves are placed alternately on the branches, and consist of two pairs of opposite pinnæ, with an odd one at the end: all the leaflets are of an elliptical shape, entire, veined, smooth, pointed, sessile, on the upper pagina of a deep green color, on the under paler: the common foot-stalk is articulated, and winged, or edged, on each side with a leafy membrane, which gradually expands towards the base of the pinnæ: the flowers are all hermaphrodite, of a bright red color, and terminate the branches in long spikes: the bractæ or floral leaves are lance-shaped or linear, colored and placed alternately upon the peduncles; the calyx is small, persistent, and five toothed; the corolla consists of five lance-shaped equal petals, at the base of which is placed the nectary, or five roundish, colored, scales; the filaments are ten, slender, somewhat longer than the corolla, and crowned

with simple antheræ, placed transversely; the receptacle is fleshy and orbicular; the germen is ovate, divided into five parts, and supports a slender style, longer than the filaments, and terminating by a tapering stigma; the capsules are five, two celled, and contain globular seeds. It is a native of South America, particularly of Surinam, and also of some of the West Indian Islands. The root, bark, and wood, of this tree have all places in the materia medica. The wood is most generally used, and is said to be a tonic, stomachic, antiseptic, and febrifuge.

It has been found very effectual in restoring digestion, expelling flatulencies, and removing habitual costiveness, produced from debility of the intestines, and common to a sedentary life. Dr. Lettsom, whose extensive practice gave him an opportunity of trying the effects of quassia in a great number of cases, says, 'In debility, succeeding febrile diseases, the Peruvian bark is most generally more tonic and salutary than any other vegetable hitherto known; but in hysterical atony, to which the female sex is so prone, the quassia affords more vigor and relief to the system than the other, especially when united with the vitriolum album, and still more with the aid of some absorbent.' In dyspepsia, arising from hard drinking, and also in diarrhœas, the doctor exhibited the quassia with great success. But, with respect to the tonic and febrifuge qualities of quassia, he says, 'I by no means subscribe to the Linnæan opinion where the author declares, *'me quidem judice chinchinam longe superat.'* It is very well known that there are certain peculiarities of the air, and idiosyncrasies of constitution, unfavorable to the exhibition of Peruvian bark, even in the most clear intermissions of fever. In these cases quassia may often be substituted with success.'

2. *Q. excelsa*, or *Q. polygama*, was named by Sir Joseph Banks, Dr. Solander, and Dr. Wright, *pricrania amara*. It is now, however, always ranked under quassia. It is very common in the woodlands of Jamaica, is beautiful, tall, and stately, sometimes being 100 feet long, and ten feet in circumference, eight feet above the ground. The trunk is straight, smooth, and tapering, sending off its branches towards the top. The outside bark is pretty smooth, of a light gray or ash color, from various lichens. The bark of the roots is of a yellow cast, somewhat like the cortex *simaruba*. The inner bark is tough, and composed of fine flaxy fibres. The wood is of a yellow color, tough but not very hard. It takes a good polish, and is used as flooring. The leaves are sub-alternate; the small leaves are in pairs, from five to eight, standing opposite to each other on short stalks, and ending with an odd one. They are of an oblong oval shape, and pointed; the ribs reddish, and the young leaves are covered with a fine brownish down. The flowers come out in bunches or clusters from the lower part of the last shoot before the leaves, and stand on round foot-stalks. The flowers are small, of a yellowish green color, with a very small calyx. The male or barren tree has flowers nearly similar to the hermaphrodite, but in it there are only the rudiments of a style. The fruit is a smooth black drupa,

round shaped, and of the size of a pea. There is but little pulp, and the nut covers a round kernel. These drupæ are generally three, sometimes two, and often only one, attached sidewise to a roundish fleshy receptacle. It flowers in October and November, and its fruit is ripe in December and January. Except the pulp of the fruit, every other part of this tree has an intensely bitter taste. In taste and virtues it is nearly equal to the quassia of Surinam, and is sold in London for the quassia amara; and it may be safely used in all cases where that drug has been thought proper, whether as an antiseptic, or in cases of weakness in the stomach and bowels. It may either be given alone, or joined with the Jesuit's bark.

3. *Q. simaruba* is common in all the woodlands in Jamaica. It grows to a great height and considerable thickness. The trunks of the old trees are black and a little furrowed. Those of the young trees are smooth and gray, with here and there a broad yellow spot. The inside bark of the trunk and branches is white, fibrous, and tough. It tastes slightly bitter. On cutting or stripping off this bark, no milky juice issues, as has been mentioned by various authors. The wood is hard and useful for buildings. It splits freely, and makes excellent staves for sugar hogsheads. It has no sensible bitter taste. The branches are alternate and spreading. The leaves are numerous and alternate. On the upper side they are smooth, shining, and of a deep green color; on the under side they are white. The flowers appear about the beginning of April. They are of a yellow color, and placed on spikes beautifully branched. The fruit is of that kind called a drupa, and is ripe towards the end of May. It is of an oval shape, is black, smooth, and shining. The pulp is fleshy and soft; the taste a nauseous sweet. The nut is flattened, and on one side winged. The kernel is small, flat, and tastes sweet. The natural number of these drupæ is five on each common receptacle; but, for the most part, there are only two or three; the rest by various accidents prove abortive. The roots are thick, and run superficially under ground to a considerable distance. The bark is rough, scaly, and warted. The inside when fresh is a full yellow, but when dry paler. It has but little smell. The taste is bitter, but not very disagreeable. This is the true cortex *simarubæ* of the shops. This tree in Jamaica is called mountain damson, bitter damson, and stave wood. On examining the fructification, Dr. Wright found this tree to be a species of quassia. Under that name he sent it to Europe, and Linnæus adopted it into his system. There are male flowers on one tree and female flowers on another; and this is invariably the case in Jamaica. Most authors who have written on the *simaruba* agree that in fluxes it restores the lost tone of the intestines, allays their spasmodic motions, promotes the secretion by urine and perspiration, removes that lowness of spirits attending dysenteries, and disposes the patient to sleep; the gripes and tenesmus are taken off, and the stools are changed to their natural color and consistence. In a moderate dose it occasions no disturbance or uneasiness:

but in a large dose it produces sickness at stomach and vomiting. Negroes are less affected by it than white people. Dr. Cullen, however, says, 'We can perceive nothing in this bark but that of a simple bitter; the virtues ascribed to it in dysentery have not been confirmed by my experience, or that of the practitioners in this country; and, leaving what others are said to have experienced to be further examined and considered by practitioners, I can only at present say that my account of the effect of bitters will perhaps explain the virtues ascribed to the simaruba. In dysentery I have found an infusion of chamomile flowers a more useful remedy.'

**QUATER'NARY,** } Lat. *quaternarius, qua-*  
**QUATER'NION,** or } *ternio.* The number four.  
**QUATER'NITY.** }

Air and ye elements, the eldest birth  
 Of nature's womb, that in *quaternion* run  
 Perpetual circle, multiform, and mix  
 And nourish all things; let your ceaseless change  
 Vary to our great Maker still new praise. *Milton.*

The number of four stands much admired, not only in the *quaternity* of the elements, which are the principles of bodies, but in the letters of the name of God. *Browne.*

The objections against the *quaternary* of elements and ternary of principles, needed not to be opposed so much against the doctrines themselves. *Boyle.*

I have not in this scheme of these nine *quaternions* of consonants, distinct known characters, whereby to express them, but must repeat the same.

*Holder's Elements of Speech.*

**QUATRAIN,** *n. s.* Fr. *quatrain.* A stanza of four lines rhyming alternately: as,

I have writ my poem in *quatrains* or stanzas of four in alternate rhyme, because I have ever judged them of greater dignity for the sound and number, than any other verse in use. *Dryden.*

**QUATRE-BRAS,** a hamlet of the Netherlands, in the province of Namur, about seven miles west of Ligny, remarkable for the memorable conflict occurring here between the British and French, on the 16th of June, 1815. It derives its name from the meeting of four roads. See **WATERLOO.**

**QUATUORVIRI,** in antiquity, formerly written **IIII Viri**, Roman magistrates, who had the care of conducting and settling the colonies sent into the provinces. There were also *quatuorviri* appointed to inspect the high-ways, to take care of repairs, &c.

**QUAVER,** *v. n.* Sax. *cpavan.* To shake the voice; speak or sing with a tremulous voice; tremble.

Miso sitting on the ground with her knees up, and her hands upon her knees, tuning her voice with many a *quavering* cough, thus discoursed. *Sidney.*

The division and *quavering*, which please so much in musick, have an agreement with the glittering of light playing upon a wave. *Bacon.*

A membrane, stretched like the head of a drum, is to receive the impulse of the sound, and to vibrate or *quaver* according to its reciprocal motions. *Ray.*

Now sportive youth  
 Carol incondite rhythms with suiting notes,  
 And *quaver* inharmonious. *Philips.*  
 We shall hear her *quavering* them half a minute  
 after us, to some sprightly airs of the opera. *Addison.*

VOL. XVIII.

If the eye and the finger remain quiet, these colors vanish in a second minute of time, but if the finger be moved with a *quavering* motion, they appear again. *Newton's Opticks.*

**QUAVER,** in music, a measure of time equal to half a crochet, a fourth part of a minim, or an eighth part of a semibreve.

**QUAY,** *n. s.* Fr. *quai.* See below. A key; an artificial bank to the sea or river, on which goods are conveniently unladen.

Kay, key, or *quay*, is a wharf or place by the water side, in a sea-port, for the loading and unloading of merchandise. The verb *cajore*, in old writers, according to Scaliger, signifies to keep in or restrain; and hence came our term *kay*; the ground where keys are made being bound in with planks and posts. *Dr. A. Rees.*

**QUAY,** or **KEY,** a long wharf, usually built of stone, by the side of a harbour or river, and having several storehouses for the convenience of loading and discharging merchant ships; with posts and rings whereby they are secured; together with cranes, capsterns, and other engines, to lift the goods in or out of the vessels which tie along side.

**QUEA'CHY,** *adj.* Originally perhaps *quacky*, *quaggy*, or *quashy*. Unsound; boggy. Not in use.

The boggy mears and *queachy* fens below.

*Drayton.*

Godwin's *queachy* sand.

*Id.*

**QUEAN,** *n. s.* Sax. *cpæan, þoncpæn.* A low or worthless woman; a strumpet.

As fit as the nail to his hole, or as a scolding *quean* to a wrangling knave. *Shakspeare.*

This well they understand like cunning *queans*,  
 And hide their nastiness behind the scenes. *Dryden.*

Such is that sprinkling which some careless *quean*  
 Flirts on you from her mop. *Swift.*

Now Tam, O Tam; had they been *queans*  
 A' plump and strapping in their teens;  
 Their sarks, instead o' creeshie flannen,  
 Been snaw-white seventeen hunder linen! *Burns.*

**QUEASY,** *adj.* Of uncertain etymology. Goth. *kuesu*, is to sicken; sicken with nausea; fastidious; squeamish.

I, with your two helps, will so practise on Benedict, that, in despite of his quick wit and his *queasy* stomach, he shall fall in love with Beatrice. *Shakspeare.*

He, *queasy* with his insolence, already  
 Will their good thoughts call from him. *Id.*

Whether a rotten slate and hope of gain,  
 Or to disuse me from the *queasy* pain  
 Of being beloved and loving,  
 Out push me first. *Donne.*

The humility of Gregory the Great would not admit the style of bishop, but the ambition of Boniface made no scruple thereof, nor have *queasy* resolutions been harboured in their successors ever since. *Broune's Vulgar Errors.*

Without question,  
 Their conscience was too *queasy* of digestion. *Dryden.*

Men's stomachs are generally so *queasy* in these cases, that it is not safe to overload them.

*Government of the Tongue.*

Y



QUEBEC, the capital of Canada and of British America, is situated at the junction of Charles River with the St. Lawrence, and is divided into the Old and New, or Upper and Lower towns. The former is on a rocky promontory, named Cape Diamond, the summit of which is 350 feet above the level of the river. On the highest part of the promontory is the citadel, composed of a whole bastion, a curtain, and half bastion, with a ditch, counterguard, covered way, and glacis to the south-west, with many other works, so that the fortifications may be considered as impregnable, both by nature and art, and require 5000 men to defend them properly.

The castle of St. Louis was burned down in 1834; the public buildings chiefly remarkable for their solidity and beauty are, a Catholic church; the ancient Jesuits' College, now occupied as a barrack for the troops; a seminary for the education of the Catholic clergy; a Protestant church court-house; the *hôtel-dieu*, or civil hospital; a poor-house; a new jail; a convent of Ursulines, which has thirty-six sisters; a general hospital, &c. There are two market-places; a place d'armes, a parade, and an esplanade. The castle of St. Louis, situated on the summit of the rock, is a handsome stone building, seated near the edge of a precipice, something more than 200 feet high, and supported towards the steep by a solid work of masonry, rising nearly half the height of the edifice, and surmounted by a spacious gallery, whence there is a most commanding prospect over the basin, the island of Orleans, Point Levi, and the surrounding country. The whole pile is 162 feet long, by forty-five broad, and three stories high. This building has been repaired and improved on a grand scale. The new jail was completed in 1814, at an expense of £15,000.

The Lower Town is the principal place of commerce, and occupies the ground at the foot of the promontory, which has been gradually gained, either by mining, or running out wharfs: it is considered unhealthy. The streets of both towns are in general irregular, uneven, and narrow, and few of them paved: but some considerable improvements in the style of building have of late been made, as well as in the plan of the streets. The houses are of unequal heights, and often covered with boards, though the frequent fires have caused some to use tin or painted sheet iron. Next the river are very extensive warehouses, and vessels come close to the wharfs to discharge their cargoes; at some of them the vessels remain afloat at low water, at others, which are not carried so far out, or where the river does not deepen so suddenly, the vessels lie dry at low water. The communication from the Lower to the Upper Town is by a winding street, at the top of which is a fortified gate.

Mountain Street, where formerly the ascent was so steep as to make it difficult for a carriage, is now passable for all sorts of vehicles. John Street, Buade Street, Fabrique Street, and the greater part of Palace Street, may be considered as the mercantile part of the Upper Town, being inhabited chiefly by merchants, retail traders, artizans, and tavern-keepers. St.

Louis Street, running nearly parallel to St. John Street, is much more elevated, airy, and agreeable, and by far the pleasantest part of the town; as such, most of the superior officers of the provincial government, and people of the first rank reside here.

On the south shore of the river, opposite Cape Diamond, is Point Levi, which with the former cape narrows the river to three-quarters of a mile; but between these points and Orleans Island is a basin, five or six miles wide, capable of holding 100 sail of the line. The rise of tide at the equinoxes is twenty-five feet. Charles's River, which empties itself at the town, issues from a lake of the same name, twelve miles from Quebec, and is only navigable for boats.

At Quebec the river begins to freeze in December, and some years the ice becomes solid and stationary, and carriages and horses cross side to side. The ice usually begins to break up in April, when a sudden thaw comes on, and generally clears the river in a few days. The first breaking up is accompanied by a noise like that of a heavy cannonade; for the current being then increased, by the melting of the ice and snow, the masses of the former are driven against each other with great fury and noise. Between Quebec and Point Levi, on the opposite shore of the St. Lawrence, a great number of ferry-boats are continually passing. In the winter, when masses of ice are floating up and down with the tide, and often when there is a strong breeze, impelled at the rate of three or four knots an hour, this passage is singularly laborious; yet it is very rare that accidents happen. It is not an uncommon thing to see several large canoes, laden with provisions for the market, crossing the river as nearly in a line as they are able to keep. They are provided with strong poles, having iron hooks at the end for grappling hold of the ice, and drag ropes; the cargoes are generally secured by a strong lashing. When large sheets of ice oppose their progress, the men, by means of the poles and ropes, which they employ with uncommon ability, get the canoe upon it, and by main force drag it perhaps fifty or sixty yards, or until they find a convenient opening to launch it again among the smaller fragments. Quebec exports grain, flour, timber, lumber, ashes, &c. In return, all the manufactures of Europe are imported. The annual value of the exports and imports amount to about £1,000,000 sterling. Mr. Bouchette estimated the population of this city at 30,000 souls.

The French first chose the ground on which Quebec now stands for a settlement, in the year 1608. Its progress was slow, owing to the hostility of the natives. In 1629 it was taken by the English, but restored. In 1690 it was fortified, and from this period gradually improved. In 1711 an attempt was made by the English and Americans, under brigadier Hill, to surprise Quebec, but it proved abortive; and it remained in possession of the French till the memorable year 1759, when it was taken by the English, under the command of the brave Wolfe, who fell in the engagement: by the peace in 1763 it was ceded, with the rest of Canada, to this country. In 1775 the Americans made an

unsuccessful attempt against this city, with the loss of about 700 men, and their commander Montgomery.

Nothing can be more beautiful than the summer views between Quebec and Montreal, both banks of the river being thickly dotted with villages and farm-houses, the latter extremely neat; and in each of the former, however small, is a church.

**QUECK**, *v. n.* Sex. *γεπικαν*, to wince. To shrink; show pain; complain. Not in use.

The lads of Sparta were accustomed to be whipped at altars, without so much as *quecking*. *Bacon*.

**QUEDAH**, or **KIDDER**, a Malay principality in the peninsula of Malacca, on the west coast, along which it extends about 150 miles, between 5° and 8° N. lat., and immediately opposite Prince of Wales's Island. It presents a considerable plain, covered with close wood, through which winds a river navigable for small craft up to the foot of the mountains. From Trang to Purlis this coast is sheltered by many islands, the distance being twenty-four leagues, low, and covered with woods. The water is also remarkably shallow, ships being obliged to anchor a great distance from the shore. Along this tract eleven small rivers empty themselves into the sea. Inland this country is from twenty to thirty-five miles in breadth, but the cultivated land no where exceeds twenty miles from the shore.

The smaller rivers of Quedah are navigable for prows, and some of them for larger vessels. Qualla Mooda is a shallow rapid stream, convenient on account of its communication with the tin mines; the annual produce of which is about 1000 peculs, and might be much more. The country to the south, being supplied with abundant moisture, is extremely productive of rice, and abounds with buffaloes, bullocks, and poultry. The other articles of commerce are tin, elephants' teeth, wax, &c.; and the imports the same as at the other Malay ports, chiefly opium and Spanish dollars. It was a place of considerable trade before the establishment of Prince of Wales's Island.

The principal sea-port, called Quedah by strangers, and Quallah Batany by the natives, is in lat. 6° N. Its river is navigable for vessels of 300 tons; but the entrance is choked up by a mud bank; and the road, where ships of burden anchor, is above two leagues from the shore. At the mouth there was a small brick fort, now in ruins. Both shores are muddy, swampy, and covered with jungle. Seven miles up the river is Allistar, where the king resides, to which place all vessels can ascend whose draught of water permits to pass the bar.

In 1786 an agreement was entered into with the king of Quedah for the cession of Pulo Penang, now Prince of Wales's Island, to the British; and, in May 1792, a regular treaty of peace and amity, to continue as long as the sun and moon give light, was concluded; by this the East India Company engaged to pay the king 6000 dollars annually, while they remained in possession of the island. In 1802 a new arrangement was entered into, by the conditions of which Yeng de per Tuan, king of Quedah, agreed to

make over to the East India Company all that part of his sea-coast between Qualla Karrican and the river side of Qualla Moodah, and measuring inland from the sea sixty orlongs; which tract of country the company engaged to protect from all enemies and pirates. The king agreed to permit the free exportation of provisions, and other articles, to Prince of Wales's Island, and engaged not to permit any European to settle in his dominions. The treaty stipulated for the apprehension and delivery of insurgents, felons, debtors, and slaves; and, in consideration of the benefits accruing to the company, they agreed to pay his majesty of Queda 10,000 dollars annually.

**QUEDLINBURG**, a large town of Prussian Saxony, on the Bude, thirty miles S.S.W. of Magdeburg. It is surrounded by an earthen mound, and divided into the Old and New Town, which has three suburbs. The abbey church is handsome, but the others are only remarkable as antiquities. Until 1802 there was a Lutheran abbey for ladies in this neighbourhood, which was admitted to rank with the principalities of the empire. In that year it was secularised. Here are manufactures of woollen, a high school, and several hospitals; and the poet Klopstock was born here.

**QUEEN**, *n. s. & v. n.* Sax. *qpen*, a woman, a wife, the wife of a king; the wife or widow of a king; a female sovereign: to play the queen.

He was lapt

In a most curious mantle, wrought by the hand  
Of his queen mother. *Shakspeare. Cymbeline.*

A threepenny bowed would hire me,

Old as I am, to queen it. *Id. Henry VIII.*

Have I a queen

Past by my fellow rulers of the world?

Have I refused their blood to mix with yours,

And raise new kings from so obscure a race?

*Dryden.*

That queen Elizabeth lived sixty-nine, and reigned forty-five years, means no more than that the duration of her existence was equal to sixty-nine, and the duration of her government to forty-five annual revolutions of the sun. *Locke.*

The meekest hind in fair Scotland

May love their sweets among;

But I, the queen of a' Scotland,

Maun lie in prison strang.

*Burns.*

Within the garden's peaceful scene

Appeared two lovely toes

Aspiring to the rank of queen.

The Lily and the Rose.

*Cowper.*

**QUEEN**, in law. The queen of England is either queen regnant queen consort, or queen dowager. The queen regent, regnant, or sovereign, is she who holds the crown in her own right; as the first, and perhaps the second, queen Mary, queen Elizabeth, and queen Anne; and such a one has the same powers, prerogatives, rights, dignities, and duties, as if she had been a king. But the queen consort is the wife of the reigning king; and she, by virtue of her marriage, is participant of divers prerogatives above other women. She is a public person, distinct from the king; and not, like other married women, so closely connected as to have lost all legal or separate existence. For the queen is of ability to purchase lands, and to convey them, to make

leases, to grant copyholds, and do other acts of ownership, without the concurrence of her lord. She is also capable of receiving a grant from the king, which no other wife is from her husband. The queen of England has separate courts and officers, distinct from the king's, not only in matters of ceremony, but even of law; and her attorney and solicitor-general are entitled to a place within the bar of his majesty's courts, together with the king's counsel. She may likewise sue and be sued alone, without joining her husband. She may also have a separate property in goods as well as lands, and has a right to dispose of them by will. In short, she is in all legal proceedings looked upon as a feme sole, and not as a feme covert; as a single, not as a married woman. For which the reason given is this: Because the wisdom of the common law would not have the king (whose continual care and study is for the public, and circa ardua regni) to be troubled and disquieted on account of his wife's domestic affairs; and therefore it vests in the queen a power of transacting her own concerns, without the intervention of the king.

The queen has also many exemptions, and minute prerogatives. For instance: she pays no toll; nor is she liable to any amercement in any court. But in general, unless where the law has expressly declared her exempted, she is upon the same footing with other subjects; being, to all intents and purposes, the king's subject, and not his equal. Nevertheless, it is equally treason to compass or imagine the death of our lady the king's companion, as of the king himself: and to violate or defile the queen consort amounts to the same high crime; as well in the person committing the fact, as in the queen herself, if consenting. If, however, the queen be accused of any species of treason, she shall, whether consort or dowager, be tried by the peers of parliament.

The husband of a queen regnant, as prince George of Denmark was to queen Anne, is her subject; and may be guilty of high treason against her: but, in the instance of conjugal infidelity, he is not subjected to the same penal restrictions.

**QUEEN DOWAGER** is the widow of the king, and as such enjoys most of the privileges belonging to her as queen consort: but it is not high treason to violate her chastity, or conspire her death, because the succession is not endangered thereby; but no man can marry her without special license from the king, on pain of forfeiting his lands and goods.

**QUEEN ANN'S COUNTY**, a county of Maryland, bounded north by Kent; east by Delaware; south-east by Caroline county; south by Talbot county; and west by Chesapeake Bay. The chief town is Antreville.

**QUEEN-APPLE**, *n. s.* Queen and apple. A species of apple.

Her cheeks with kindly claret spread,  
Aurora-like new out of bed,

Or like the fresh *queen-apple's* side,

Blushing at sight of Phœbus' pride. *Sidney.*

The *queen-apple* is of the summer kind, and a good cyder-apple mixed with others. *Mortimer.*

The winter *queening* is good for the table. *Id.*

**QUEEN CATHERINE'S FORELAND**, the north-east point of Terra del Fuego, at the east entrance into the straits of Magellan, discovered by Frobisher in 1576.

**QUEEN CHARLOTTE'S FORELAND**, the south-east extremity of New Caledonia. Long. 167° 14' E., lat. 22° 15' N. Also the name of the south-west point of New Hanover, in the eastern seas; discovered by captain Carteret in 1767. It is a high bluff point, and the land around has a great number of little hummocks or hills. Long. 148° 27' E., lat. 2° 29' S.

**QUEEN CHARLOTTE'S ISLAND**, an island in the Pacific, about six miles long and one broad, discovered in 1767 by captain Wallis. He describes it as sandy and level, full of trees, without underwood, and abounding with scurvy-grass. The canoes appeared to be about thirty feet long, four feet broad, and three and a half deep. Two of these, being brought along-side of each other, were fastened at the distance of about three feet, by cross beams, passing from the larboard gunwale of one to that of the other, in the middle, and near to each end. The inhabitants were handsome, of a middle stature, and dark complexion, with long black hair. Long. 138° 4' W., lat. 19° 18' S.

**QUEEN CHARLOTTE'S ISLANDS**, a group in the North Pacific Ocean, of which we know very little, except that they lie off the west coast of North America; the largest being of a triangular form, about 170 miles long, and in some places sixty broad. These islands were observed by captain Cook, who imagined them to form part of the continent. They were first discovered to be islands by Dixon, in 1787. Being visited by captain Gray, of the United States, he called them Washington's Islands, and found several convenient harbours. Vancouver coasted along the shore, and observed that near the sea the land was elevated, but rose gradually into rugged and uneven mountains towards the interior of the principal island. He understood that the inhabitants cultivated a species of tobacco. Long. from 131° to 133° 7' W., lat. 52° to 54° 22' N.

**QUEEN CHARLOTTE'S ISLANDS**, another group discovered by captain Carteret in 1767, consisting of Egmont's Island or New Guernsey, Lord Howe's Island or New Jersey, and several others. Carteret sent a cutter, with the master and a party of men, on shore; when a quarrel ensued, respecting the cutting down of a cocoa-tree, in which many Indians were killed, and, on the side of the English, the master and three of the seamen were wounded, and soon after died. Captain Carteret, being desirous to get in some water, veered the ship close to the shore, but was himself induced to order several shots to be fired, by which several Indians seem to have been killed, before he could attain his purpose. These islands were discovered in 1595 by Mendana, the principal being called by him Santa Cruz. The others are very inconsiderable.

'The inhabitants of Egmont Island,' says Carteret, 'are extremely nimble, vigorous, and active, and seem to be as well qualified to live in the water as upon the land; for they were in and

out of their canoes almost every minute. The canoes that came out against us from the west end of the island might probably, upon occasion, carry about a dozen men, though three or four manage them with amazing dexterity; we saw, however, others of a large size upon the beach, with awnings or shades over them. We got two of their bows, and a bundle of their arrows, from a canoe; and with these weapons they do execution at an incredible distance. One of them went through the boat's washboard, and dangerously wounded a midshipman in the thigh. Their arrows were pointed with flint, and we saw among them no appearance of any metal. The country in general is woody and mountainous, with many valleys intermixed. Several small rivers flow from the interior part of the country into the sea, and there are many harbours upon the coast. Long. 163° 30' to 165° 10' E., lat. 9° 50' to 11° 20' S.

**QUEEN CHARLOTTE'S SOUND**, a northern bay of the south island of New Zealand, where captain Cook erected a post with a union flag, and took possession of the country in the name and for the use of king George III. In sailing either in or out with little wind, attention must be had to the tides, which flow about nine or ten o'clock at the full and change of the moon, and rise and fall between seven and eight feet. The variation of the compass was found, from good observation, to be 13° 5' E. The land about consists wholly of high hills and deep valleys, well stored with a variety of hard timber, fit for all purposes except masts. The sea abounds with fish; so that, without going out of the cove where they lay, the Endeavour's crew caught every day, with hooks and lines, a quantity sufficient to serve the ship's company: the inhabitants, amounting to about 400, had straggling houses along the shore. See **ZEALAND, NEW**.

**QUEEN'S COUNTY**, anciently called **Leix**, a shire in the province of Leinster and kingdom of Ireland, so named from queen Mary of England. It is about thirty miles in length by twenty-five in breadth, contains about 146,000 inhabitants, 25,000 houses, and its superficies measures 235,000 acres. Here are nine baronies, viz. Ballyadams, Cullinagh, Maryborough East, Maryborough West, Portenehinch, Slieumargue, Stradbally, Tinnehinch, and Upper Ossory. The ecclesiastical subdivision is made into twenty-nine parishes, and twenty-three parts of parishes. The chief towns are Ballynakill, Maryborough (so named also from Mary queen of England), the Assizes Town, Mountrath, part of the elegant town of Portarlington, Stradbally, and Mountmellick. There are here many noble seats, and many resident gentry. Much of the boggy districts has been reclaimed, by which both the climate and soil have benefited. Between the King's and Queen's counties is that great natural boundary, seventeen miles in length, called the Sliebh-bloom Range, or the Ard-narerin Mountains. The first appellation appears to signify the 'mountain dedicated to Beal's Day;' the second means 'The height of Ireland.' In the whole length of this great chain there is but one pass, called the Gap of Glandine, and even this a difficult one. A remarkable circumstance

relating to the Sliebh-Bloom mountains is, that the north side of the whole range is singularly fertile, while the south is completely barren. Here also are the sources of the only two rivers of consequence in the county, the Barrow and the Nore; the former rendered navigable by deepening and by lateral cuts, but the latter unmanageable from its rapidity and sudden floods. The Queen's County abounds in mineral productions; the great bed of coal, called the Leinster district, lies between the rivers Nore and Barrow, and rests upon limestone: this coal is of the non-flaming species called stone, and sometimes Kilkenny coal; the vein reaching this last district. The limestone of this region exhibits many remarkable appearances; such as great dislocations, parallel disturbances in the coal strata, and an apparent change in their nature; the occurrence of irregular beds and veins of siderocalcite, or brown spar, traversing the limestone; and, lastly, the vast caves discovered at or near the junction of the calcareous and coal strata. The soil of this county in general is gravelly, favorable for the growth of corn; and the pasture is found peculiarly adapted for the cheese farmer, who sometimes deceives the factor by imposing his cheese as English-made. Queen's-County cheese is held in high estimation at home. The ancient families of this district were the O'More's, Fitzpatrick's, and Wandesford's. Many beautiful specimens of military and ecclesiastical antiquities still survive, amongst which the celebrated fortified rock called 'Dunamaze' should not be omitted: this still interesting place, formerly the citadel of the O'More's of Leix, was occupied as a post of defence and security as early as the third century. The ruins now visible were erected by the chieftain O'More. Abbey Leix and Aghaboe are the most interesting of the monastic remains. Queen's County returns three members to the imperial parliament, two for the county, and one for the borough of Portarlington.

**QUEEN'S-COUNTY**, a county of New-York, in the west part of Long Island; bounded north by Long Island Sound; east by Suffolk county; south by the Atlantic; and west by King's county. Chief towns, Jamaica and North Hempstead.

**QUEENBOROUGH**, a post and market town, situate at the western extremity of the Isle of Sheppey, Kent, at the mouth of the Medway, forty-five miles east from London. The houses are neat, uniform, and regularly built. The church is a plain, ancient structure. Here is a small copperas manufactory; and in the town is a guildhall and a prison. This place is a distinct liberty, and it is governed by a mayor, four jurats, and two bailiffs. Its magistrates hold quarterly courts, and also general sessions every half year. It returned two members to parliament, the right of election being in the corporation and burgesses, the number about 150, but is now disfranchised. Market on Monday.

**QUEENSFERRY**, a royal borough and parish on the south bank of the Firth, where the river is not above two miles broad; nine miles west of Edinburgh. It was so named from the celebrated queen Margaret, wife of Malcolm

Canmore, who frequented this passage much, and patronised the town. It consists of one street, chiefly inhabited by seafaring people. Its chief manufacture is soap. This borough unites with Stirling, Dunfermline, Culross, and Inverkeithing, in electing a representative in the imperial British parliament. It is governed by a provost, three bailies, dean of guild, and town council. It has two piers on the east and west, and the coast abounds with cod, haddocks, whiting, skate, flounders, herrings, lobsters, oysters, crabs, &c.

QUEENSTOWN, a neat place of Upper Canada, on the Niagara, under the ridge called Queenstown Heights. It is the depot for the merchandise brought from Montreal and Quebec, for the Upper province, and is remarkable for the romantic beauty and grandeur of its situation. It has a good capacious harbour, a church, court-house, stores for government and for the Indian department, wharfs, and barracks. Much commercial activity is displayed during the season of navigation. Queenstown suffered much during the late war.

QUEER, *adj.* 'Of this word the original is not known,' says Dr. Johnson: 'a correspondent supposes a queer man to be one who has a quære to his name in a list.' But there is a Teut. *kuerh*, of this signification. Odd; strange; particular; churlish.

He never went to bed till two in the morning because he would not be a *queer* fellow; and was every now and then knocked down by a constable, to signalise his vivacity. *Spectator.*

QUELLING, or KOUEILING, a city of China, of the first rank, capital of QUANGSEE, (which see,) environed by mountains. Its name is derived from a species of oderiferous flower, abundant in the neighbourhood. A rapid river, but not navigable, flows under the walls. This city is fortified, but does not equal other Chinese capitals in wealth and population. Long. 109° 51' E., lat. 25° 12' N.

QUEIS, or QUEISS, a river of the Prussian states, which rises in Silesia, divides it from Lusatia, and falls into the Bober, above the town of Sagan. Its banks were, in September 1813, the scene of a battle between the French and Prussians.

QUELL, *v. a. & n. s.* } Sax. *cyellan*; Dan. }  
 QUELLER. } *quale*. To kill; }  
 crush; subdue: hence, as a noun-substantive, }  
 murder; violent death: a queller is a conqueror. }

What cannot we put upon  
 His spongy followers, who shall bear the guilt  
 Of our great *quell*? *Shakspeare. Macbeth.*

What avails  
 Valour or strength, though matchless, *quelled* with  
 pain,

Which all subdues, and makes remiss the hands  
 Of mightiest. *Milton's Paradise Lost.*

Hail, Son of the Most High,  
 Queller of Satan, on thy glorious work  
 Now enter. *Id. Paradise Regained.*

This *quelled* her pride, but other doubts remained,  
 That, once disdaining, she might be dislained.

*Dryden.*  
 He is the guardian of the publick quiet, appointed  
 to restrain violence, to *quell* seditions and tumults,  
 and to preserve that peace which preserves the world.

*Atterbury.*

QUELPAERT, an island in the eastern seas, south of the peninsula of Corea. It was made known to Europeans in 1635 by the wreck of a Dutch vessel here, called the Sparrow-hawk. The crew were carried to the capital of Corea, whence they with difficulty made their escape. The island was also coasted by La Perouse, in 1787. It is chiefly composed of a mountain, about 6000 feet high, whence the land slopes down to the sea. The jealous character of the nation prevents any considerable intercourse between it and Europeans. Long. 126° 35' E., lat. 33° 14' N.

QUELQUECHOSE. *n. s.* Fr. *quelquechose*. A trifle; a kickshaw. A word not adopted.

From country grass to comfitures of court,  
 Or city's *quelquechoses*, let not report  
 My mind transport. *Donne.*

QUENCH, *v. a. & v. n.* } Saxon *cpencan*; }  
 QUENCH'ABLE, *adj.* } Goth. *kuangwen*. }  
 QUENCH'ER, *n. s.* } To extinguish; cool; }  
 QUENCH'LESS, *adj.* } allay: hence to de- }  
 stroy: as a neuter verb, to grow cool; the ad- }  
 jectives and noun substantive corresponding. }

The fire had power in the water, forgetting his  
 own virtue; and the water forgot his own *quenching*  
 nature. *Wisd. m. xix. 20.*

Since stream, air, sand, mine eyes and ears con-  
 spire,  
 What hope to *quench*, where each thing blows the  
 fire? *Sidney.*

This is the way to kindle, not to *quench*.  
*Shakspeare.*

But if all aim but this be levelled false,  
 The supposition of the lady's death  
 Will *quench* the wonder of her infamy. *Id.*

Dost thou think, in time  
 She will not *quench*, and let instructions ente  
 Where folly now possesses? *Id. Cymbeline.*

Come, bloody Clifford, rough Northumberland,  
 I dare your *quenchless* fury to more rage.  
*Shakspeare.*

Milk *quencheth* wild-fire better than water, because  
 it entereth better. *Bacon's Natural History.*

When death's form appears, she feareth not  
 An utter *quenching* or extinguishment;  
 She would be glad to meet with such a lot  
 That so she might all future ill prevent. *Davies.*  
 The judge of torments, and the king of tears,  
 He fills a burnished throne of *quenchless* fire.

*Crashaw.*  
 Subdued in fire the stubborn metal lies;  
 One draws and blows reciprocating air;  
 Others to *quench* the hissing mass prepare.

*Dryden.*  
 You have already *quenched* sedition's brand,  
 And zeal, which burnt it, only warms the land.  
*Id.*

Covered with skin and hair keeps it warm, being  
 naturally very cold, and also to *quench* and dissipate  
 the force of any stroke, and retund the edge of any  
 weapon. *Ray.*

Beseech God, that he will inflame thy heart with  
 this heavenly fire of devotion; and, when thou hast  
 obtained it, beware that thou neither *quench* it by  
 any wilful sin, or let it go out again for want of  
 stirring it up and employing it. *Duty of Man.*

When your work is forged, do not *quench* it in  
 water to cool it, but throw it down upon the floor or  
 hearth to cool of itself; for the *quenching* of it in  
 water will harden it. *Moran's Mechanical Exercises.*

Every draught, to him that has *quenched* his thirst,

is but a further *quenching* of nature, a provision for  
 ibleum and diseases, a drowning of the spirits.

South.

His heart with wounds unnumbered riven,  
 His back to earth, his face to heaven,  
 Fallen Hassan lies—his unclosed eye  
 Yet lowering on his enemy,  
 As if the hour that sealed his fate,  
 Surviving left his *quenchless* hate.

Byron.

QUENTIN, (St.), a fine town in the north-east of France, and department of the Aisne, is situated on the Somme, and near the canals of Crozat and St. Quentin. It stands on an eminence, in a strong position, but its fortifications have been long neglected. It contains a public square, in which is situated the hotel de ville, and the ancient cathedral, both in the Gothic style. It has long been noted for its linen, thread, cambric, lawn, gauze, and latterly for its cottons. In these a surprising number of hands are employed, and a great export trade carried on with Holland, Germany, and other foreign countries. The French were defeated here in a general engagement by the Spaniards, in 1557. Population 11,000. Twenty-two miles south of Cambrai, forty south by east of Arras.

QUERCUS, the oak tree, a genus of the polyandria order and monœcia class of plants; natural order fiftieth, amentaceæ: CAL. nearly quinquefid: COR. none; the stamina are from five to ten in number: FEMALE CAL. monophyllous, very entire, and scabrous: COR. none; the styles are from two to five, and there is an ovate seed. Dr. Rees describes eighty-four species of quercus; the following are some of the most important.

Q. ægilops, the large prickly-cupped Spanish oak, grows seventy or eighty feet high, or more, with a very large trunk, and widely spreading head, having a whitish bark, large oblong-oval deeply serrated smooth leaves. The serratures bowed backwards, and large acorns placed in singularly large prickly cups. This is a noble species, nearly equal in growth to our common English oak.

Q. cerris, the smaller prickly-cupped Spanish oak, grows thirty or forty feet high, and has oblong, lyre-shaped, pinnatifid, transversely jagged leaves, downy underneath, and small acorns placed in prickly cups.

Q. coccifera, the scarlet or kermes oak, grows but fourteen or fifteen feet high, branching all the way, and of bushy growth; with large oval, undivided, indented, spinous leaves; and producing small glandular excrescences, called kermes or scarlet grain, used by the dyers. See COCCUS and KERMES.

Q. esculus, of Pliny, or the cut-leaved Italian oak, grows about thirty feet high, having a purplish bark, oblong deeply sinuated smooth leaves, and long slender close-sitting acorns in very large cups.

Q. gramuntia, the Montpellier holly-leaved evergreen oak, grows forty or fifty feet high; and has oblong-oval, close-sitting, sinuated spinous leaves, downy underneath, bearing a resemblance to the leaves of the holly.

Q. ilex, the common evergreen oak, grows forty or fifty feet high, having a smooth bark,

oval and oblong, undivided, serrated, petiolated leaves, downy and whitish underneath. The varieties are broad-leaved, narrow-leaved, and sometimes both sorts and other different shaped leaves on the same tree; also sometimes with sawed and prickly leaves.

Q. Moluccensis, Moluccan oak, commonly called American live oak, grows about forty feet high, having oval, spear-shaped, smooth, entire leaves, and small oblong eatable acorns.

Q. phellos, the willow-leaved American oak, grows forty or fifty feet high, having long narrow, smooth, entire leaves, like those of the willow. There is a variety called the dwarf willow-leaved oak.

Q. prinus, the chestnut-leaved American oak, grows fifty or sixty feet high; having large oblong-oval smooth leaves, pointed both ways, the edges sinuated serrated, with the sinuses uniformly round.

Q. robur, the common English oak, grows from about sixty or seventy to 100 feet high, with a prodigiously large trunk, and monstrous spreading head; oblong leaves, broadest towards the top, the edges acutely sinuated, having the angles obtuse. There is a variety, having the leaves finely striped with white. This species grows in great abundance all over England, in woods, forests, and hedge-rows.

The following are the dimensions of some of the finest oaks at Welbeck, as stated in a pamphlet by Hayman Rooke, esq., F. S. A.:—The Green Dale Oak is said to be 700 years old. Girth of the trunk above the arch thirty-five feet; height of the arch ten feet three inches; width six feet three inches; and height of the tree, to the top of the live stump, fifty-four feet. The Porters are two very large trees, and are so called from the circumstance of there formerly having been a gate placed between them. The first measures in circumference at the ground thirty-eight feet; at a yard high twenty-seven feet; at two yards twenty three feet; total height ninety-eight feet six inches; and solidity 848 feet! The other in girth at the surface thirty-four feet; at one yard high twenty-three feet; at two yards twenty feet; height eighty-eight feet; and solidity 744 feet. The Duke's Walking Stick, in girth at the ground twenty-one feet; at one yard high fourteen feet; stem seventy feet six inches; total height 111 feet; and solidity 440 feet. The Oak and Ash. Girth of both at the ground thirty-six feet; of the oak at one yard high eighteen feet; at two yards fifteen feet four inches, and height ninety-two feet. The ash is comparatively very small; it leaves the oak at a small distance above the ground, and unites again at eight or nine feet high; then branches out, and towers with it for some thirty or forty feet. Dr. Walker mentions an oak, at Loch Arkeg in Lochaber, which measured twenty-four feet six inches, at the height of four feet from the ground.

The English oak is as remarkable for its slowness of growth and longevity as for its bulk; the trunk has been often observed to have reached the size of not more than twenty inches, and sometimes not more than fourteen, in the space of fourscore years. In regard to bulk we have

an account of an oak belonging to lord Powis, growing in Broomfield wood, near Ludlow in Shropshire, in 1764, the trunk of which measured sixty-eight feet in girth, twenty-three in length, and which, reckoning ninety feet for the larger branches, contained in the whole 1455 feet of timber, round measure, or twenty-nine load and five feet, at fifty feet to a load. The Cowthorp oak, near Wetherby in Yorkshire, lays a claim to being the father of the forest. Dr. Hunter, who, in his edition of Evelyn, has given an engraving of it, says that within three feet of the surface it measures sixteen yards, and close to the ground twenty-six. In 1776, though in a ruinous condition, it was eighty-five feet high, and its principal limb extended sixteen yards from the bole. The foliage was very thin. If this measurement was taken as the dimensions of the real stem, the size of this tree would be enormous; but like most very large trees, its stem is short, spreading wide at the base, the roots rising above the ground like buttresses to the trunk, which is similar, not to a cylinder, but to the frustum of a cone. Mr. Marshman says, 'I found it in 1768 at four feet, forty feet six inches; at five feet, thirty-six feet six inches; and at six feet, thirty-two feet one inch.' In the principal dimensions it is exceeded by the Bentley oak, of which the same writer gives the following account:—'In 1759 the oak in Holt forest, near Bentley, was at seven feet, thirty-four feet. There is a large excrescence at five and six feet, that would render the measure unfair. In 1778 this tree was increased half an inch in ten years. It does not appear to be hollow, but by the trifling increase I conclude it not sound.' These dimensions, however, are exceeded by those of the Boddington oak, near the turnpike road between Cheltenham and Tewkesbury, in the vale of Gloucester. The stem is remarkably collected at the root, the sides of its trunk being much more upright than those of large trees in general; and yet its circumference at the ground is about twenty paces; measuring with a two foot rule it is more than eighteen yards. At three feet high it is forty-two feet, and where smallest, i. e. from five to six feet high, it is thirty-six feet. At six feet it swells out larger, and forms an enormous head, which has been furnished with huge, and probably extensive, arms. But time and the fury of the wind have robbed it of much of its grandeur, and the greatest extent of arm in 1783 was eight yards from the stem.

In the Gentleman's Magazine for May, 1794, we have an account of an oak tree growing in Penshurst Park in Kent, together with an engraving. It is called the bear or bear oak, from being supposed to resemble that which Camden thought gave name to the county of Berkshire. The dimensions of the tree are these:—

	Ft.	In.
Girth close to the ground . . .	35	6
Girth one foot from the ground . . .	27	6
Girth five feet from the ground . . .	24	0
Height taken by shadow . . .	73	0
Girth of lowest, but not largest, limb . . .	6	9

With respect to longevity, Linné gives an account of an oak 260 years old; but we have

had traditions of some in England (how far to be depended upon we know not) that have attained to more than double that age.

*Q. rubra*, the red Virginian oak, grows about sixty feet high, having a dark grayish bark, long obtusely sinuated leaves, with the sinuses terminated by bristly points, and have sometimes red spotted veins, but generally dyeing in autumn to a reddish color, remaining on the trees late in the season.

*Q. suber*, the cork tree, grows thirty or forty feet high, having a thick, rough, fungous, cleft bark, and oblong-oval, undivided, serrated leaves, downy underneath. This species furnishes that useful material cork; it being the bark of the tree, which becomes of a thick fungous nature, under which, at the same time, is formed a new bark, and, the old one being detached for use, the tree still lives, and the succeeding young bark becomes also of the same thick spongy nature in six or seven years, fit for barking, having likewise another fresh bark forming under it, becoming cork like the others in the like period of time; and in this manner these trees wonderfully furnish the cork for our use, of which are made the corks for bottles, bungs for barrels, and numerous other useful articles. The tree grows in great plenty in Spain and Portugal, and from these countries we receive the cork. The Spaniards burn it, to make that kind of light black we call Spanish black, used by painters. The Spaniards line stone walls with cork, which not only renders them very warm, but corrects the moisture of the air. All the above species of quercus produce flowers annually in the spring, about April or May, of a yellowish color, but make no ornamental appearance, and are males and females separated in the same tree; the males being in loose amentums, and the females sitting close to the buds in thick leathery hemispherical calyxes, succeeded by the fruit or acorns, which are oval nuts fixed by their base into rough permanent cups, and mostly sit quite close, and some on short foot-stalks, ripening in autumn, which in the common English oak are in great abundance, and often in tolerable plenty on some of the other sorts; those of all the kinds serve for propagating their respective species; they are also excellent food for swine and deer, the common acorns in particular. All the above species will prosper in any middling soil and open situation, though in a loamy soil they are generally more prosperous; however there are but few soils in which oak will not grow; they will even thrive tolerably in gravelly, sandy, and clayey land, as may be observed in many parts of this country of the common oak. Besides the grand purposes to which the timber is applied in navigation and architecture, and the bark in tanning of leather, there are other uses to which the different parts of this tree have been referred. The Highlanders use the bark to dye their yarn of a brown color, or, mixed with copperas, of a black color. The acorns are a good food to fatten swine and turkeys. See *OAK*.

*Q. marina*, the sea oak, in botany, the name of one of the broad-leaved dichotomous sea fucuses. It is not agreed among the late botanists, what was the sea oak of Theophrastus; Clusius and Cæsalpinus suppose it to have been a species of

the shrubby coralline; but Theophrastus says the sea oak had a long, thick, and fleshy leaf; whence we may conclude it to have been of the fucus class.

**QUERELE**, *n. s.* Fr. *querelle*; Lat. *querela*. A complaint to a court. See **QUARREL**.

A circumduction obtains not in causes of appeal, but in causes of first instance and simple *querelle* only. *Ayliffe*.

**QUERETARO**, a city in the intendency of Mexico, the largest after Mexico in this part of the republic. From north to south it is sheltered by a mountain; and thence begins its celebrated glen, irrigated by a large river, the waters being introduced by means of hidden aqueducts, which are reduced to twelve currents running from the mother stream. Thus the water is let in upon 2000 houses, to which are attached gardens, abounding in a thousand kinds of fruits and flowers, European and American. It has three grand squares, from which the streets extend to the four cardinal points. Here is also a celebrated aqueduct for carrying the water to the city, having forty arches of thirty-five yards high. The church is magnificent, and there are several convents. In this city are fabricated fine cloths, baizes, &c., and several tanneries. Humboldt also visited a great manufactory of cigars, in which 3000 people, including 1000 women were employed. Here are consumed 130 reams, and 2770 pounds of tobacco leaf. Queretaro is situated 6374 feet above the level of the sea. Humboldt estimates the population at 35,000. Ninety-five miles north-west of Mexico.

**QUERFURT**, a town of Prussian Saxony, in the government of Merseburg, on the river Quern. It was formerly the chief place of a principality. Population 2500. Fifteen miles west of Merseburg, and twenty-nine west of Leipsic.

**QUERIA**, in botany, a genus of the trigynia order, and triandria class of plants; natural order twenty-second, caryophillei: *CAL.* pentaphyllous; *COR.* none; *CAPS.* unilocular and trivalved, with one SEED. There are two species, viz.:—1. *Q. Canadensis*, and 2. *Q. Hispanica*.

**QUERIMBA**, the name of islands, extending along the eastern coast of Africa, to the south of Cape Delgado. When discovered by the Portuguese, they were inhabited by Arabs, who were nearly exterminated by their European visitors. The Querimbas have since been re-peopled by Portuguese and their slaves from Mosambique. The principal island is four or five miles long, containing about thirty farm houses, and a small fort. It was lately plundered by the pirates of Madagascar.

**QUERIMONIOUS**, *adj.* } Lat. *querimonia*.  
**QUERIMONIOUSLY**, *adv.* } Querulous; complaining: the adverb corresponding.

To thee, dear Thom, myself addressing,  
Most *querimoniously* confessing. *Denham*.

**QUERY**, *n. s. & v. a.* } Lat. *quere*. A question.  
**QUERIST**, *n. s.* } tion; matter of enquiry: an enquirer; proposer of questions.

I shall propose some considerations to my gentle *querist*. *Spectator*.

I shall conclude, with proposing only *some queries*, in order to a farther search to be made by others.

*Newton*.

This shews the folly of this *query*, that might always be demanded, that would impiously and absurdly attempt to tie the arm of omnipotence from doing any thing at all, because it can never do its utmost.

*Bentley*.

Three Cambridge sophs,  
Each prompt to *query*, answer, and debate. *Pope*.  
The juggling sea god when by chance trepanned  
By some instructed *querist* sleeping on the strand,  
Impatient of all answers, strait became  
A stealing brook. *Swift's Miscellanias*.

**QUERN**, *n. s.* Sax. *cpeorn*; Dan. *querno*; Swed. *quarne*. A hand-mill.

Skim milk, and sometimes labour in the *quern*,  
And bootless make the breathless huswife churn. *Shakespeare*.

Some apple coloured corn  
Ground in fair *querns*, and some did spindles turn. *Chapman*.

**QUERPO**, *n. s.* Span. *cuerpo*. A dress close to the body; a waistcoat.

I would fain see him walk in *querpo*, like a cased rabbit, without his holy fur upon his back. *Dryden*.

**QUERULOUS**, *adj.* } Lat. *querulus*. Mourn-  
**QUERULOUSLY**, *adv.* } ing; whining; complaining: the adverb corresponding.

Although they were a people by nature hard-hearted, *querulous*, wrathful, and impatient of rest and quietness, yet was there nothing of force to work the subversion of their state, till the time before-mentioned was expired. *Hooker*.

The pressures of war have cowed their spirits, as may be gathered from the very accent of their words, which they prolate in a whining kind of *querulous* tone, as if still complaining and crest-fallen.

*Howel's Vocal Forest*.

Though you give no countenance to the complaints of the *querulous*, yet curb the insolence of the injurious. *Locke*.

His wounded ears complaints eternal fill,  
As unoled hinges, *querulously* shrill. *Young*.

A *querulous* old woman's voice  
His humorous talent next employs;  
He scolds and gives the lie. *Cowper*.

**QUESNAY** (Francis), a French physician and writer on political economy, was born in 1694, near Montfort l'Amaury, in the isle of France. His father was a farmer, and he acquired the rudiments of his profession as a surgeon in the country, when, going to the metropolis, he became secretary to a society for the improvement of surgery. At length he obtained the situation of physician to madame de Pompadour, and through her interest became physician to the king. His simplicity of manners and disinterestedness are said to have formed a strong contrast with the characters of those around him; towards the latter part of life he became the leader of the political economists of France. Quesnay, however, by no means anticipated the result of his doctrines; and was much attached to the royal family, and especially to the king, who called him his thinker 'penseur.' He was author of a Philosophical Essay on the Animal Economy, 3 vols. 12mo.; and various surgical and medical works, besides articles in the Encyclopédie, and tracts on Physiocracy, or the Government most Advantageous to the Human Race, 1768, 8vo., &c.



**QUESNE** (Abraham marquis Du), admiral of the naval forces of France, was born in Normandy in 1610. He contributed to the defeat of the naval power of Spain before Gattari; was dangerously wounded before Barcelona in 1642, and on other occasions: he went into the service of the Swedes, and became vice-admiral; gave the Danes an entire defeat, killed their admiral, and took his ship. He was recalled into France in 1647, and commanded the squadron sent to Naples. The naval affairs of France being much fallen, he fitted out divers ships for the relief of the royal army that blocked up Bourdeaux; which was the principal cause of the surrender of the town. He was very fortunate in the last wars of Sicily, where he beat the Dutch thrice, and De Ruyter was killed. He also obliged the Algerines to sue for peace from France in a very humble manner. Asia, Africa, and Europe, felt the effects of his valor. He was a Protestant; nevertheless the king bestowed on him the land of Bouchet. He died in 1658.

**QUESNEL** (Pasquier), an able French divine, of the congregation of the Oratory, distinguished on account of the church dissensions to which his writings gave rise. He was born at Paris in 1634, and early devoted himself to literary studies. He gave offence to the court of Rome by an edition of the works of Leo the Great in 1675; but that which excited the greatest animosity was his New Testament, with moral reflections, in 8 vols. 8vo.; from which 101 propositions being extracted, they were condemned by the celebrated bull, Unigenitus, as favoring the doctrines of the Jansenists. Father Quesnel retired to Brussels, and afterwards to Amsterdam, where he died in 1719. His New Testament was translated into English by Mr. Russell, and published in 1729, 4 vols. 8vo. Dr. Adam Clarke strongly recommends it.

**QUESNOY**, a fortified town of French Flanders, having a population of 4000, besides a small garrison, and some trade in wood, silk, cottons, starch, and tobacco. It was taken by the Austrians in 1793, but retaken by the French in 1794. Twenty miles east by north of Cambray. It is also the name of another, but less remarkable town of French Flanders, on the Deule. Population 3700. Six miles north-west of Lisle.

**QUEST**, *n. s. & v. n.* } Fr. *queste*. Search; }  
**QUESTANT**, } enquiry; examination; }  
**QUESTMAN**, } act of seeking: those }  
**QUESTMONGER**, } who seek taken collec- }  
**QUESTRIST**. } tively: to go in search: }  
 a questant and questrist mean a seeker or searcher: a questman or questmonger, a starter of law-suits or prosecutions.

None but such as this bold ape unblest,  
 Can never thrive in that unlucky quest.

*Spenser.*

If lusty love should go in quest of beauty,  
 Where should he find it fairer than in Blanch?

*Shakspeare.*

What's my offence?

Where is the evidence that doth accuse me?  
 What lawful quest have given their verdict up  
 Unto the frowning judge? *Id. Richard III.*

O place and greatness! millions of false eyes  
 Are stuck upon thee; volumes of report

Run with these false and most contrarious *quests*  
 Upon thy doings. *Id. Measure for Measure.*

See, that you come

Not to woo honour, but to wed it; when  
 The bravest *questant* shrinks, find what you seek,  
 That fame may cry you loud. *Shakspeare.*

Six and thirty of his knights,

Hot *questrists* after him, met him at the gate,  
 Are gone with him tow'rd Dover. *Id.*

Their principal working was upon penal laws,  
 wherein they spared none, great nor small, but  
 raked over all new and old statutes, having ever a  
 rabble of promoters, *questmongers*, and leading jurors  
 at their command. *Bacon.*

Gad not abroad at every quest and call

Of an untrained hope or passion. *Herbert*

An aged man in rural weeds,

Following, as seemed, the quest of some stray ewe.  
*Milton.*

There's not an African,

That traverses our vast Numidian deserts

In quest of prey, and lives upon his bow,

But better practices these boasted virtues. *Addison.*

'Twould be not strange, should we find Paradise  
 at this day, where Adam left it; and I the rather  
 note this, because I see there are some so earnest in  
 quest of it. *Woodward.*

The insolence of his mistress quickly disgusted  
 him, and he went up to London in quest of more  
 suitable employment. *Johnson.*

**QUESTION**, *n. s., v. n. & v. a.* } French and }  
**QUESTIONABLE**, *adj.* } Span. *ques-* }  
**QUESTIONARY**, } tion; Ital. }  
**QUESTIONER**, *n. s.* } *questione;* }  
**QUESTIONLESS**, *adj.* } Lat. *questio.* }

Enquiry; interrogatory; examination; dispute;  
 matter of dispute or debate; controversy; judi-  
 cial trial; examination by torture; act of seek-  
 ing: to question is to enquire; debate by inter-  
 rogatory; and, as a verb active, examine one by  
 questions; doubt: questionable is, doubtful;  
 disputable; suspicious: questionary, enquiring;  
 questioner, he who enquires: questionless,  
 doubtless: clear; without or beyond enquiry.

There arose a *question* between some of John's  
 disciples and the Jews about purifying. *St. John.*

Suddenly out of this delightful dream

The man awoke, and would have *questioned* more;  
 But he would not endure the woful theme. *Spenser.*

If we being defendants do answer, that the cere-  
 monies in *question* are godly, comely, decent, pro-  
 fitable for the church, their reply is childish and un-  
 orderly to say, that we demand the thing in *question*.  
*Houker.*

Your accustomed clemency will take in good  
 worth the offer of these my simple labors, bestowed  
 for the necessary justification of laws heretofore made  
*questionable*, because not perfectly understood.  
*Id. Dedication.*

This is not my writing,

Though I confess much like the character

But out of *question* 'tis Maria's hand. *Shakspeare.*

As it more concerns the Turk than Rhodes,

So may he with more facile *question* bear it;

For that it stands not in such warlike brace

But altogether lacks the abilities

That Rhodes is dressed in. *Id.*

I pray you think you *question* with a Jew

You may as well use *question* with the wolf,

Why he hath made the ewe bleat for the lamb

But hark you, Kate,  
I must not have you henceforth *question me*  
Whither I go. *Id. Henry IV.*

Be thy advent wicked or charitable,  
Thou comest in such a *questionable* shape,  
That I will speak to thee. *Id. Hamlet.*

*Questionless* hence it comes that many were mis-  
taken. *Raleigh.*

He that *questioneth* much shall learn much, and  
content much; but especially if he apply his *ques-*  
*tions* to the skill of the persons whom he asketh.

*Bacon's Essays.*

Unreasonable subtility will still seem to be rea-  
soning; and at least will *question*, when it cannot  
answer. *Holyday.*

It is *questionable*, whether the use of steel springs  
was known in those ancient times. *Wilkins.*

This construction is not so indubitably to be re-  
ceived as not at all to be *questioned*. *Browne.*

That persons drowned float the ninth day, when  
their gall breaketh, is a *questionable* determination,  
both in the time and cause. *Id. Vulgar Errors.*

'Tis time for him to shew himself, when his very  
being is called in *question*, and to come and judge  
the world, when men begin to doubt whether he  
made it. *Tillotson.*

If it would purchase six shillings and three-pence  
weighty money, he had proved the matter in *question*.  
*Locke.*

*Questionless* duty moves not so much upon com-  
mand as promise; now that which proposes the  
greatest and most suitable rewards to obedience, and  
the greatest punishments to disobedience, doubtless is  
the most likely to enforce the one and prevent the  
other. *South.*

Such a presumption is only sufficient to put the  
person to the rack or *question*, according to the civ-  
il law, and not bring them to condemnation.

*Ayliffe's Parergon.*

O impotent estate of human life!

Where fleeting joy does lasting doubt inspire,  
And most we *question* what we most desire.

*Prior.*

Nor are these assertions that dropped from their  
pens by chance, but delivered by them in places  
where they profess to state the points in *question*.

*Atterbury's Preface.*

How easy is it for a man to fill a book with quo-  
tations, as you have done, that can be content with  
any thing, however foreign to the *question*!

*Waterland.*

Our own earth would be barren and desolate,  
without the benign influence of the solar rays, which  
without *question* is true of all the other planets.

*Bentley.*

I grow laconick even beyond laconicism; for  
sometimes I return only yes or no to *questionary*  
epistles of half a yard long. *Pope to Swift.*

In point of honour to be tried,

Suppose the *question* not your own. *Swift.*

It is *questionable*, whether Galen ever saw the  
dissection of a human body. *Baker.*

QUESTOR, or QUÆSTOR, in Roman antiquity,  
an officer who had the management of the public  
treasure. The questorship was the first office  
any person could bear in the commonwealth, and  
gave a right to sit in the senate. At first there  
were only two; but afterwards two others were  
created, to take care of the payment of the armies  
abroad, of the sale of the plunder, booty, &c., for  
which purpose they generally accompanied the  
consuls in their expeditions; on which account  
they were called peregrini, as the first and prin-  
cipal two were called urbani. The number of

questors was afterwards greatly increased. They  
had the care of the decrees of the senate; and  
hence came the two officers of questor principis,  
or augusti, sometimes called candidatus prin-  
cipis, whose office resembled in most respects  
that of our secretaries of state; and the questor  
palatii.

QUESTUARY, *adj.* Lat. *questus*. Studi-  
ous of profit.

Although lapidaries and *questuary* enquirers affirm  
it, yet the writers of minerals conceive the stone of  
this name to be a mineral concretion, not to be found  
in animals. *Browne.*

QUEVEDO DE VILLEGAS (Francis), a cele-  
brated Spanish poet, born at Madrid in 1570.  
He was descended from a noble family, and was  
made a knight of St. James; but was thrown  
into prison by order of count Olivarez, whose  
administration he satirized in his verses, and was  
not set at liberty till after that minister's dis-  
grace. Quevedo wrote some heroic, lyric, and  
facetious poems: he also composed several treat-  
ises on religious subjects, and translated some  
authors into Spanish. He died in 1645. His  
most celebrated works are, 1. The Spanish Par-  
nassus. 2. The Adventurer Buseon. 3. Vi-  
sions of Hell Reformed, &c. His youth was  
spent in the service of his country in Italy,  
where he distinguished himself by his sagacity  
and prudence.

QUIB'BLE, *n. s. & v. n.* } Lat. *quidlibet*.

QUIB'BLER. } A cavil; pun: to  
pun; to play on the sound of words.

The first service was neat's tongues sliced, which  
the philosophers took occasion to discourse and *quib-*  
*ble* upon in a grave formal way. *L'Estrange.*

This may be of great use to immortalize puns and  
*quibbles*, and to let posterity see their forefathers were  
blockheads. *Addison.*

Having once fully answered your *quibble*, you will  
not, I hope, expect that I should do it again and  
again. *Waterland.*

Quirks or *quibbles* have no place in the search after  
truth. *Watts.*

QUIBERON, a town of France, on a long  
and narrow peninsula of the same name, which,  
with some islands, forms a noble bay, having two  
harbours defended by batteries. A British force  
landed here in 1746, but was repulsed. In June  
and July, 1795, a number of the French emi-  
grants in England prevailed on the British gov-  
ernment to land them in this bay; but they  
were soon overpowered by the republican troops,  
suffered great loss in their flight, and those of  
their associates who were made prisoners under-  
went the sentence of the law against emigrants  
of being shot. Twelve miles north of Belle-  
Isle, twenty-three south-west of Vannes, and  
twenty-four S. S. E. of L'Orient.

QUICK, *adj. & n. s.* } Sax. *cpic*; Swed.

QUICKEN, *v. a.* } *quick*; Dan. and Belg.

QUICKENER, *n. s.* } *quik*; Goth. *kuik*. Alive;

living; a living animal or plant; living or pec-  
uliarly sensible parts: to quicken is to make  
alive; become living: quickener one who makes  
alive; the adjective is almost obsolete.

If there be *quick raw* flesh in the risings, it is an  
old leprosy. *Leviticus xiii. 10.*

All they that go down into the dust shall kneel before him; and no man hath quickened his own soul. *Psalm xxii. 30.*

Who shall judge the quick and the dead at his appearing. *St. Paul.*

They rub out of it a red dust, that converteth after a while into worms, which they kill with wine when they begin to quicken. *Saundy's Journey.*

Peeping close into the thick,

Might see the moving of some quick,

Whose shape appeared not;

But were it fairy, fiend, or snake,

My courage earned it to wake, *Spenser.*

And manful thereat shot.

These hairs which thou dost ravish from my chin will quicken and accuse thee; I'm your host; With robbers hands, my hospitable favour You should not ruffle thus. *Shakespeare. King Lear.*

This my mean task would be

As heavy to me, as 'tis odious; but

The mistress which I serve quickens what's dead,

And makes my labours pleasures. *Id. Tempest.*

If Stanley held that a son of king Edward had still the better right, it was to teach all England to say as much; and therefore that speech toucheth the quick. *Bacon.*

As the sun makes; here noon, there day, there night,

Melts wax, dries clay, makes flowers, some quick, some dead *Davies.*

Thence shall come,

When this world's dissolution shall be ripe, With glory and power to judge both quick and dead. *Milton.*

He throws

His influence round, and kindles as ne goes; Hence flocks and herds, and men and beasts and fowls With breath are quickened, and attract their souls. *Dryden.*

Seized with sudden smart,

Stung to the quick, he felt it at his heart. *Id.*

The heart is the first part that quickens, and the last that dies. *Ray on the Creation.*

For inclosing of land, the most usual way is with a ditch and bank set with quick. *Mortimer.*

The thought of this disgraceful composition so touches me to the quick that I cannot sleep. *Arbuthnot's John Bull.*

Scarifying gangrenes, by several incisions down to the quick, is almost universal, and with reason, since it not only discharges a pernicious ichor, but makes way for topical applications. *Sharp.*

QUICK, *adj. & adv.*

QUICK'EN, *v. a.*

QUICK'ENER, *n. s.*

QUICK'LY, *adv.*

QUICK'NESS, *n. s.*

QUICKSIGHT'ED, *adj.*

QUICKSIGHT'EDNESS, *n. s.*

From quick, alive. Vivacious; active; nimble; swift; sprightly; ready: as an adverb, nimbly; speedily: to quicken is to hasten; accelerate; sharpen; excite: quickener, the thing or person that quickens or actuates: quickly and quickness correspond with quick: and quicksighted means sharp of sight; of acute perception.

Though my senses were astonished, my mind forced them to quicken themselves; because I had learnt of him how little favour he is wont to shew in any matter of advantage. *Sidney.*

Prayers whereunto devout minds have added a piercing kind of brevity, thereby the better to express that quick and speedy expedition, wherewith ardent affections, the wings of prayer, are delighted to present our suits in heaven. *Hooker.*

Ready in gybes, quick answered, saucy, and As quarrellous as the weazle.

*Shakespeare. Cymbeline.*

Thou comest to use thy tongue: thy story quickly. *Shakespeare.*

Honour, that is gained and broken upon another, hath the quickest reflection, like diamonds cut with facets; and therefore let a man contend to excel any competitors of his in honour, in outshooting them, if he can, in their own bow. *Bacon.*

You may sooner by imagination quicken or slack a motion, than raise or cease it; as it is easier to make a dog go slower, than to make him stand still. *Bacon's Natural History.*

Others were appointed to consider of penal laws and proclamations in force, and to quicken the execution of the most principal. *Hayward.*

This shall your understanding clear,

Those things from me that you shall hear,

Conceiving much the quicker. *Drayton's Numphid.*

The best choice is of an old physician and a young lawyer; because, where errors are fatal, ability of judgment and moderation are required; but, where advantages may be wrought upon, diligence and quickness of wit. *Wotton.*

If passion work like a hot-reined horse,

'Twill quickly tire itself. *Massinger.*

What any invention hath in the strength of its motion is abated in the slowness of it; and, what it hath in the extraordinary quickness of its motion, must be allowed for in the great strength that is required unto it. *Wilkins.*

A man of great sagacity in business, and he preserved so great a vigour of mind, even to his death, when near eighty, that some, who had known him in his younger years, did believe him to have much quicker parts in his age than before. *Clarendon.*

Off he to her his charge of quick return

Repeated. *Milton's Paradise Lost.*

Love and enmity, aversion and fear, are not able whetters and quickeners of the spirit of life in all animals. *More.*

Thy generous fruits, though gathered ere their prime,

Still shewed a quickness; and maturing time But mellowed what we write to the dull sweets of rhyme. *Dryden.*

They gave those complex ideas, that the things they were continually to give and receive information about, might be the easier and quicker understood. *Locke.*

Though any commodity should shift hands never so fast, yet, if they did not cease to be any longer traffick, this would not at all make or quicken their vent. *Id.*

No body will deem the quickighted amongst them to have very enlarged views in ethicks. *Id.*

The ignorance that is in us no more hinders the knowledge that is in others, than the blindness of a mole is an argument against the quickightedness of an eagle. *Id.*

Ginger renders it brisk, and corrects its wildness, and juice of corinths, whereof a few drops tinge and add a pleasant quickness. *Mortimer.*

The animal, which is first produced of an egg, is a blind and dull worm: but that which hath its resurrection thence, is a quick-eyed, volatile, and sprightly fly. *Grew's Cosmologia.*

They endeavour by brandy to quicken their taste already extinguished. *Tatler.*

A man must have passed his noviciate in sinning before he comes to this, be he never so quick a proficient. *Swift.*

Joy, like a ray of the sun, reflects with a greater

ardour and *quickness*, when it rebounds upon a man from the breast of his friend. *Id.*

An argument of great force to *quicken* them in the improvement of those advantages to which the mercy of God had called them by the gospel. *Rogers.*

No article of religion hath credibility enough for them; and yet these same cautious and *quicksighted* gentlemen can swallow down this sottish opinion about percipient atoms. *Bentley.*

Sees by degrees a purer blush arise.

And keener lightnings *quicken* in her eyes. *Pope.*

The desire of fame hath been no inconsiderable motive to *quicken* you in the pursuit of those actions which will best deserve it. *Swift.*

**QUICK'LIME, n. s.** Lat. *calx viva*, quick and lime. Lime unquenched.

After burning the stone, when lime is in its perfect and unaltered state, it is called *quickslime*. *Hill.*

**QUICKLIME.** See **LIME** and **CHEMISTRY**.

**QUICKSAND, n. s.** Quick and sand. Moving sand; unsolid ground.

Undergirding the ship, and fearing lest they should fall into the *quicksands*, they strake sail, and so were driven. *Acts xxvii.*

What is Edward, but a ruthless sea?  
What Clarence, but a *quicksand* of deceit?

*Shakspeare.*

But when the vessel is on *quicksands* cast,  
The flowing tide does more the sinking haste.

*Dryden.*

I have marked out several of the shoals and *quicksands* of life, in order to keep the unwary from running upon them. *Addison.*

When ministry rests upon public opinion, it is not, indeed, built upon a rock of adamant; it has however some stability. But, when it stands upon private humour, its structure is of stubble, and its foundation is on *quicksand*. *Burke.*

**QUICKSET, v. a.** Quick and set. To plant with living plants.

In making or mending, as needeth thy ditch,  
Get set to *quicksset* it, learn cunningly which.

*Tusser.*

The batful pastures fenced, and most with *quicksset* mound.

*Drayton.*

A man may ditch and *quicksset* three poles a day, where the ditch is three foot wide and two foot deep.

*Mortimer.*

Plant *quickssets* and transplant fruit-trees towards the decrease. *Evelyn's Kalendar.*

Nine in ten of the *quicksset* hedges are ruined for want of skill. *Swift's Miscellanies.*

**QUICKSILVER, n. s.** } Quick and silver.

**QUICKSILVERED, adj.** } Mercury: overlaid with mercury.

Cinnabar maketh a beautiful purple like unto a red rose; the test was wont to be made in Libya, of brimstone and *quicksilver* burnt. *Peacham.*

Metal is more difficult to polish than glass, and is afterwards very apt to be spoiled by tarnishing, and reflects not so much light as glass *quicksilvered* over does; I would propound to use instead of the metal a glass ground concave on the foreside, and as much convex on the backside, and *quicksilvered* over on the convex side. *Newton's Opticks.*

Pleasures are few; and fewer we enjoy;  
Pleasure, like *quicksilver*, is bright and coy;  
We strive to grasp it with our utmost skill,  
Still it eludes us, and it glitters still:  
If seized at last, compute your mighty gains,  
What is it, but rank poison in your veins?

*Young.*

**QUICKSILVER, or mercury.** See **MERCURY**.

**QUID PRO QUO**, in law, what for what, denotes the giving one thing of value for another; or the mutual consideration and performance of both parties to a contract.

**QUID PRO QUO**, or **QUI PRO QUO**, is also used in physic to express a mistake in the physician's bill, where quid is written for quo, i. e. one thing for another; or of the apothecary in reading quid for quo, and giving the patient the wrong medicine. Hence the term is in general extended to all blunders or mistakes committed in medicine, either in the prescription, the preparation, or application of remedies.

**QUIDAM, n. s.** Lat. *quidam*. Somebody. Not used.

For envy of so many worthy *quidams*, which catch at the garland which to you alone is due, you will be persuaded to pluck out of the hateful darkness those so many excellent poems of yours which lie hid, and bring them forth to eternal light. *Spenser.*

**QUID'DIT, n. s.** } Fr. *que dit*, corrupted  
**QUID'DITY.** } from *quidlibet*; low Lat.  
*quidditas*. A subtilty; an equivocation: quiddity, essence; that which is a proper answer to the question, quid est?

Why may not that be the skull of a lawyer? where be his *quiddits* now? his quilletts? his cases? and his tricks? *Shakspeare.*

Misnomer in our laws, and other *quiddities*, I leave to the professors of law. *Camden's Remains.*

He could reduce all things to acts,  
And knew their natures and abstracts,  
Where entity and *quiddity*  
The ghosts of defunct bodies fly. *Hudibras.*

**QUIESCENCE, n. s.** } Lat. *quiesco*. Rest;  
**QUIESCENT, adj.** } repose; state of quiet: the adjective corresponding.

Whether the earth move or rest, I undertake not to determine: my work is to prove that the common inducement to the belief of its *quiescence*, the testimony of sense, is weak and frivolous. *Glanville.*

Though the earth move, its motion must needs be as insensible as if it were *quiescent*. *Id.*

The right side, from whence the motion of the body beginneth, is the active or moving side; but the sinister is the weaker or more *quiescent* side. *Browne's Vulgar Errors.*

Sight takes in at a greater distance and more variety at once, comprehending also *quiescent* objects, which hearing does not. *Holder.*

If it be in some part movent, and in some part *quiescent*, it must needs be a curve line, and so no radius. *Grew.*

Pression or motion cannot be propagated in a fluid in right lines beyond an obstacle which stops part of the motion, but will bend and spread every way into the *quiescent* medium, which lies beyond the obstacle. *Newton's Opticks.*

**QUI'ET, adj., n. s., &** } Fr. *quiet*; Span.  
**QUI'ETER, n. s.** [v. u.] } and Port. *quieto*; Ital.  
**QUI'ETISM,** } *quicto*; Lat. *quietus*.  
**QUI'ETLY, adv.** } At rest; still; peace-  
**QUI'ETNESS, n. s.** } able; smooth; mild:  
**QUI'ETSOME, adj.** } as a noun substantive,  
**QUI'ETUDE, n. s.** } rest; tranquillity;

peace; security: as a verb active, to calm; lull; pacify: quietism is tranquillity, real or affected, of the mind and temper: quietly and quietness corresponding with the senses of quiet, adjective: quietism is calm; still (obsolete): quietude, repose; stillness.

They laid wait for him, and were quiet all the night.

Let it be in the ornament of a meek and quiet spirit.

This cruel quietness neither returning to mislike nor proceeding to favour; gracious, but gracious still after one manner.

Breaking off the end for want of breath, And sliding soft, as down to sleep her laid, She ended all her woe in quiet death.

Let the night be calm and quiet some, Without tempestuous storms or sad affray. That which we move for our better instruction sake, turneth into anger and choler in them; they grow altogether out of quietness with it; they answer fumingly.

This life is best, If quiet life is best; sweeter to you, That have a sharper known.

Stop effusion of our christian blood, And establish quietness on every side.

Although the rebels had behaved themselves quietly and modestly by the way as they went; yet they doubted that would but make them more hungry to fall upon the spoil in the end.

What miseries have both nations avoided, and what quietness and security attained by their peaceable union!

The lowest degree of faith, that can quiet the soul of man, is a firm conviction that God is capable.

From the equal distribution of the phlegmatick humour, the proper alloy of fervent blood, will flow a future quietude and serenity in the affections.

Let no man for his own poverty become more oppressing in his bargain, but quietly, modestly, and patiently recommend his estate to God, and leave the success to him.

Justly thou abhorrest That son, who on the quiet state of man Such trouble brought.

What is called by the poets apathy or dispassion, by the sceptics indisturbance, by the Molinists quietism, by common men peace of conscience, seeras all to mean but great tranquillity of mind.

There fixed their arms, and there renewed their name, And there in quiet rules.

Putting together the ideas of moving or quieting corporeal motion, joined to substance, we have the idea of an immaterial spirit.

Indulgent quiet, power serene, Mother of peace, and joy, and love.

If we compare the quietness and chastity of the Bolognese pencil to the bustle and tumult that fills every part of a Venetian picture, without the least attempt to interest the passions, their boasted art will appear a mere struggle without effect.

**QUIETISTS**, a religious sect, famous towards the close of the seventeenth century. They were so called from a kind of absolute rest and inaction, which they supposed the soul to be in, when arrived at that state of perfection, which they called the unitive life; in which state they imagined the soul wholly employed in contemplating its God, to whose influence it was entirely submissive. In this state the soul no longer needs prayers, hymns, &c., being entirely occupied with the contemplation of the Deity. Molinos, a Spanish priest, is the reputed author

of Quietism; though the Illuminati in Spain had certainly taught something like it before. The most celebrated patroness of Quietism was madam De la Mothe Guyon, a lady of excellent character; whose sentiments were refuted in 1697 by Bossuet. She was defended by the celebrated archbishop Fenelon, whose book, however, was condemned by Innocent XII. and the archbishop himself obliged to read the sentence, though he retained his opinions to the last. The Quietists spread through Italy, France, and the Netherlands. A sect similar to this had appeared at Mount Athos in Thessaly, near the end of the fourteenth century, called Hesychasts. They were a branch of the mystics, or those more perfect monks, who, by long and intense contemplation, endeavoured to arrive at a tranquillity of mind free from every degree of tumult and perturbation.

**QUILL**, *n. s.* Goth. *koyle*, a writing reed, or Lat. *calamus*? The hard strong feather of which pens are made; dart of a porcupine; a reed of weavers and musicians.

The presumptuous damsel rashly dared The goddess' self to challenge to the field, And to compare with her in curious skill, Of works with loom, with needle, and with quill.

Birds have three other hard substances proper to them; the bill, which is of a like matter with the teeth, the shell of the egg, and their quills.

With her nimble quills his soul doth seem to hover, And eye the very pitch that lusty bird did cover.

I will only touch the duke's own department in that island, the proper subject of my quill. His flying fingers and harmonious quill Strike seven distinguished notes, and seven at once they fill.

Being rooted so little way in the skin, nothing near so deeply as the quills of fowls, they are the more easily ejaculated.

Those lives they failed to rescue by their skill, Their mute would make immortal with her quill.

Near these was the black prince of Monomotapa, by whose side was seen the quill-darting porcupine.

From him whose quills stand quivered at his ear, To him that notches sticks at Westminster.

**QUILLS** are denominated from the order in which they are fixed in the wing; the second and third quills being the best for writing, as they have the largest and roundest barrels. Crow-quills are chiefly used for drawing. To harden a quill that is soft, thrust the barrel into hot ashes, stirring it till it is soft, then, taking it out, press it almost flat upon your knee with the back of a penknife, and afterwards reduce it to a roundness with your fingers. If you have a number to harden, set water and alum over the fire, and while it is boiling dip the barrels of the quills for a minute, and then lay them by.

**QUILLET**, *n. s.* Lat. *quidlibet*. Subtily; nicety; fraudulent distinction; petty cant.

Why may not that be the skull of a lawyer? where be his quiddits now? his quilllets? his cases? and his tricks?

A great soul weighs in the scale of reason, what

it is to judge of rather than dwells with too scrupulous a diligence upon little *quillets* and niceties.

*Digby.*

Ply her with love letters and billets,  
And bait them well for quirks and *quillets*.

*Hudibras.*

**QUILLET** (Claude), an eminent Latin poet in the seventeenth century, born at Chinon, in Touraine. He practised physic there with reputation; but having declared against the pretended possession of the nuns of Loudun, in a MS. treatise, afterwards deposited in the library of the Sorbonne, he was obliged to retire into Italy, where he became secretary to the marshal d'Estrées, the French ambassador at Rome. In 1655 Quillet having published in Holland a Latin poem, entitled *Callipædia*, under the name of Galvidus Lætus, he there inserted some verses against cardinal Mazarine and his family; but retrenched what related to the cardinal in another edition, and dedicated it to him, Mazarine having, before it was printed, given him an abbey. He died in 1661, aged fifty-nine, after having given Menage all his writings, and 500 crowns to pay the expense of printing them; but the abbé took the money and papers, and published none of them. His *Callipædia* has been translated into English verse.

**QUILLOTA**, a province of Chili, bounded by Coquimbo on the north, on the east by Aconcagua, on the south by Melipilla, and on the west by the sea. It is twenty-five leagues in length, and sixteen in breadth. Its rivers are the Longotoma, Ligua, Aconcagua, and Limache, which flow down from the Cordillera west. This district is one of the most populous, and the most productive in gold of any in Chili. Its hemp and honey are also esteemed. It has a parish, with the churches of St. Dominic, St. Francis, St. Augustine, and a college formerly of the Jesuits. The province contains also the cities of Piazza, Plazilla, Ingenio, Casablanca, and Petrorca. Quillota contains likewise a number of ports, the most considerable of which are Papudo, Quintiro, l'Erradura, Concon, and Valparaiso. They cultivate in this province all kinds of grain and vines, and fabricate much rigging, cords, thread, and soap. Inhabitants 14,000.

**QUILLOTA**, the capital of the above province, is pleasantly situated in a valley, on the borders of the river Aconcagua. Long. 71° 18' W., lat. 32° 50' S.

**QUILOA**, a city and sea-port of Eastern Africa, capital of a country of the same name. It is built on an island situated close to the mainland. Long. 39° 47' E., lat. 8° 41' S.

**QUILT**, *n. s. & v. a.* Fr. *couette*; Ital. *coltre*; Belg. *kulcht*; Lat. *culcita*, *culcitra*. A cover made by stitching some soft substance between layers of cloth or silk: to stitch in this manner.

The sharp steel arriving forcibly  
On his horse neck before the quilted fell,  
Then from the head the body sundred quite.

*Spenser.*

Quilts of roses and spices are nothing so helpful,  
as to take a cake of new bread, and bedew it with a little sack.

*Bacon.*

A bag quilted with bran is very good, but it drieth too much.

*Id. Natural History.*

Entellus for the strife prepares,

Stripped of his quilted coat, his body bares,

Composed of mighty bone. *Druden's Æneis.*

In both tables the beds were covered with magnificent quilts amongst the richest sort. *Arbuthnot.*

She on the quilt sinks with becoming woe,

Wrapt in a gown, for sickness and for show. *Pope.*

**QUIMPER**, or **KIMPER CORENTIN**, a town of France, the capital of the department of Finisterre, is situated on the declivity of a hill, at the confluence of two navigable rivers, and divided into the Old and New Town. It is surrounded with a wall and towers, and is the see of a bishop. The objects of interest are the cathedral, exchange, public library, and botanical garden. The river is capable of receiving vessels of 200 tons, while those of greater burden find safe anchorage in the neighbouring road of Benaudet. It has manufactures of stone-ware, a good trade, and 7000 inhabitants. Thirty-four miles south-east of Brest, and 115 west of Rennes.

**QUIMPERLE**, a town of France, department of Finisterre, on the Isolle. It has two churches, manufactures of pottery, tobacco-pipes, and stone-ware, and 4200 inhabitants: also paper-mills and tanneries. Twelve miles north-west of L'Orient, and twenty-eight east by south of Quimper.

**QUIN** (James), a celebrated performer on the English stage, born at London in 1693. He was intended for the bar; but, on the death of his father, appeared on the stage at Drury-lane. In 1720 he exhibited his powers in Falstaff, and soon after appeared to great advantage in the character of Sir John Brute: but it was not until Booth's quitting the stage that Quin appeared to full advantage in the part of Cato. Garrick's eminence gradually withdrew the public attention from Quin, who observed that 'Garrick like Whitefield, was a new religion, but all would come to church again;' a remark which extorted a well-known epigram from his rival. He continued a favorite performer until 1748, when, on some disgust between him and Rich the manager, he retired to Bath, and only came up annually to act for the benefit of his friend Ryan. While Quin continued upon the stage he constantly kept company with the literati of the age, particularly Pope, Swift, and lord Chesterfield. His judgment in reading the English language was such that Frederick prince of Wales appointed him preceptor to his children, and George III. afterwards gave him a pension, though he stood in no need of it. He died of a fever in 1766.

**QUINARIUS** was a small Roman coin, equal to half the denarius, and consequently worth about three pence three farthings of our money. See **MONEY**. It was called *quinarius*, because it contained the value of five asses, in the same manner as the denarius was named from its containing ten.

**QUINARY**, *adj.* Lat. *quinarius*. Consisting of five.

This *quinary* number of elements ought to have been restrained to the generality of animals and vegetables.

*Boyle.*

**QUINAUT** (Philip), a celebrated French poet, born in Paris in 1635. He cultivated poetry

from his infancy, and sixteen dramatic pieces of his were acted between 1653 and 1666. He also studied the law, and made a fortune by marrying a rich widow. He died in 1688, after having enjoyed a handsome pension from Louis XIV. for many years.

QUINCE, *n. s.* Fr. *coin*; Teut. *quidden*, from Cydon, in Crete. A tree and its fruit. See below.

They call for *dats* and *quinces* in the pastry.  
*Shakspeare.*

A *quince*, in token of fruitfulness, by the laws of Solon, was given to the brides of Athens upon the day of their marriage.  
*Peacham on Drawing.*

The *quince* tree is of a low stature; the branches are diffused and crooked; the flower and fruit is like that of the pear tree; but, however cultivated, the fruit is sour and astringent, and is covered with a kind of down: of this the species are six.  
*Miller.*

QUINCE, in botany. See PYRUS.

QUINCH, *v. a.* The same with QUECK, which see. To stir; flounce; as in resentment or pain.

Bestow all my soldiers in such sort as I have, that no part of all that realm shall be able to dare to quinch.  
*Spectator.*

QUINCUNX, *n. s.* Lat. *quincunx*. A mode of planting trees, whereby they are disposed in a square, consisting of five trees, one at each corner, and a fifth in the middle, repeated; so that viewed through an angle of the square or parallelogram, they represent equal or parallel alleys.

Brown produces several examples in his discourses about the *quincunx*.  
*Ray on the Creation.*

Of a pentagon or *quincuncial* disposition, Sir Thomas Browne produces several examples in his discourses about the *quincunx*.  
*Id.*

He whose lightning pierced the Iberian lines,  
Now forms my *quincunx*, and now ranks my vines.  
*Pope.*

QUINCY, a post-town of Norfolk county, Massachusetts, eight miles south of Boston. It is a pleasant town, and contains a Congregational and an Episcopal church. The inhabitants are mostly engaged in agriculture, but large quantities of boots and shoes are manufactured here. This town is famous for being the residence of the honorable John Adams, late president of the United States.

QUINDECENVIRI, in Roman antiquity, a college of fifteen magistrates, whose business it was to preside over the sacrifices. They were also the interpreters of the Sybil's books; which, however, they never consulted but by an express order of the senate.

QUINDIU, a high and craggy range of mountains of South America, in the province of Popayan, Colombia. By these mountains there is a passage from the provinces of Popayan to Santa Fe, considered as one of the most difficult in the Andes. In the finest season it cannot be traversed in less than ten or twelve days, and consists chiefly of a thick uninhabited forest. Not even a hut is to be seen, nor are any means of subsistence to be found. Travellers always furnish themselves with a month's provisions, since it often happens that, by the melting of the snows, they can descend neither on the side

of Carthago, nor that of Ibaque. The highest point, the Garito del Paramo, is 11,489 feet above the level of the sea. The pathway, which forms the passage of the Cordillera, is only twelve or sixteen feet in breadth, and has the appearance in several places of an artificial gallery. See POPAYAN.

Humboldt and Bonpland traversed this mountain in October 1801, followed by twelve oxen, which carried their collections and instruments, amidst a deluge of rain.

QUININA, or QUININE, in chemistry, a vegetable alkali, obtained from pale cinchona (bark), by the following process:—A pound of bruised bark is boiled in about a gallon of water, to which three fluid drachms of sulphuric acid have been previously added. A similar decoction is repeated with about half the quantity of liquid, and so on till all the soluble matter is extracted. The decoctions are then mixed together, and strained; and powdered slaked lime is added in a proportion somewhat greater than necessary to saturate the acid; the precipitate that ensues (a mixture of quinine and sulphate of lime), is collected, dried, and boiled for some minutes in strong alcohol, which is then decanted off, while still hot, and fresh portions successively added for the repetition of the same operation, until it ceases to act on the residuum, which is then merely sulphate of lime. The different alcoholic solutions are then put into a retort or still, and considerably evaporated, during which, and especially on cooling, transparent plates of quinine are deposited. It is very insoluble in water, and its taste is very bitter. It unites with the acids, forming crystallisable salts. The sulphate is of a dull white color, silky and flexible: it is, like the alkali, soluble in alcohol; it burns away without leaving any residuum. According to Mons. Pelletier and Caventou, it is composed of

Quinine	. . . . .	100
Sulphuric acid	. . . . .	10·9147
but M. Baup describes a crystallised sulphate as well as a super-sulphate. The first consists of		
Quinine	. . . . .	1 prime 45
Sulphuric acid	. . . . .	5
Water	. . . . .	4·5

54·5

The acetate is remarkable for the manner in which it crystallises. Its crystals are flat needles, of a pearly lustre, grouped in silky bundles, or in stars.

Quinine is very soluble in ether. The sulphate of quinine, in doses of from six to twelve grains, has been found an effectual remedy against intermittent fevers. It is said that the red or yellow bark yields the most febrifuge quinine.

Quinine affords a large quantity of ammonia, when subjected to destructive distillation, and consequently contains azote as one of its elements. Analysed by Mr. Brande, it afforded,

Carbon	. . . . .	73·80
Azote	. . . . .	13·00
Hydrogen	. . . . .	7·65
Oxygen	. . . . .	5·55

100·00

According to Dumas and Pelletier,

Carbon . . . . .	74.14
Hydrogen . . . . .	6.77
Azote . . . . .	8.80
Oxygen . . . . .	10.76

M. Baup adopts 45 as the prime equivalent of quinine. He states its sulphate as follows:—

Supersulphate in rectangular prisms.	
1 atom 45 . . . . .	61.644
2 . . . . .	10 . . . . . 13.698
16 . . . . .	18 . . . . . 24.658

100.000

**QUINQUAGESIMA**, Latin *quingagesima*.

A Sunday, so called because it is the fiftieth day before Easter, reckoned by whole numbers: Shrove Sunday.

**QUINQUANGULAR**, *adj.* Lat. *quinque* and *angulus*. Having five corners.

Each talus, environed with a crust, conforming itself to the sides of the talus, is of a figure *quinquangular*. Woodward.

Exactly round, ordinately *quinquangular*, or having the sides parallel.

*More's Antidote against Atheism.*

**QUINQUARTICULAR**, *adj.* Latin *quinque* and *articulus*. Consisting of five articles.

They have given an end to the *quinquarticular* controversy, for none have since undertaken to say more. Sanderson.

**QUINQUATRIA**, or **QUINQUATRUS**, was a festival kept at Rome in honor of Minerva, which began on the 18th of March, or, as others will have it, on the 19th, and lasted five days. On the first day they offered sacrifices and oblations without the effusion of blood; the second, third, and fourth, were spent in shows of gladiators; and on the fifth day they went in procession through the city. Scholars had a vacation during the solemnity, and presented their masters at this time with a gift or fee called *Minerval*. Boys and girls used to pray to the goddess Minerva for wisdom and learning, of which she had the patronage. Plays were acted, and disputations held, at this feast, on the subjects of polite literature. The *quinquatria* were so called because they lasted five days. There seems to be a strong resemblance betwixt this festival and the *Panathæa* of the Greeks.

**QUINQUENNALIS**, in Roman antiquity, a magistrate in the colonies and municipal cities of that empire, who had much the same office as the *ædile* at Rome.

**QUINQUEREMIS**, in the naval architecture of the ancients, a name given to a galley which had five rows of oars. They divided their vessels in general into *monocrota*, and *polycrota*. The former had only one tire of rowers; the latter had several tires of them. The *quinqueremes* of the ancients had 420 men in each; 300 of whom were rowers, and the rest soldiers.

**QUINQUEVIRI**, in Roman antiquity, an order of five priests, peculiarly appointed for the sacrifices to the dead, or celebrating the rites of *Erebus*.

**QUIN'SY**, *n. s.* Corrupted from *SQUINANCY*, which see. A tumid inflammation in the throat, which sometimes produces suffocation.

VOL. XVIII.

The throttling *quinsy*, 'tis my star appoints,  
And rheumatisms I send to rack the joints. *Dryden*.  
Great heat and cold, succeeding one another, occasion pleurisies and *quinsies*. *Arbutnot on Air*.

**QUIN'SY**. See **MEDICINE**.

**QUINT**, *n. s.* Fr. *quint*. A set of five.

For state has made a *quint*

Of generals he's listed in't. *Hudibros*.

**QUINTAIN**, *n. s.* Fr. *quintain*. A tilting post for the game of *quintin*. See **QUINTIN**.

My better parts

Are all thrown down; and that, which here stands up,

Is but a *quintain*, a mere lifeless block. *Shakspeare*.

**QUINTAINE**, **QUINTIN**, an instrument used by the common people in the days of chivalry, to tilt against. It consisted of an upright post, on the top of which a cross-post turned upon a pivot; at one end of the cross-post was a broad board, and at the other a bag of sand. The practice was to ride against the board with a lance, and at such speed as to pass by before the sand-bag could strike the tilter on the back.

**QUINTANA**, in Roman antiquity, the fifth gate of the Roman camps, which were generally square, and had four other principal gates. The *quintana* was near the *questorium*. The soldiers were here instructed in the discipline of the *Palatia*. Upon the irruption of the *Istri* into the Roman camps, which they plundered, *Livy* says, 'Ad *Questorium* forum *quintanamque* *pervenerunt*.'

**QUINTE**, a bay and harbour on Lake Ontario, to the westward of Kingston. It is formed between the irregular peninsula of prince Edward county on the south, and the mainland of the midland district on the north. The length, through the various crooked turns it makes, is little short of fifty miles, but its breadth only between six and twelve miles. The isthmus formed between it and Lake Ontario, in the township of Murray, is not more than three furlongs broad. This inlet affords to vessels safe shelter from the heavy gales frequently of the lake.

**QUINTESENCE**, *n. s.* } Lat. *quinta es-*  
**QUINTESENTIAL**, *adj.* } *sentia*. A fifth  
being; see the extract from *Watts*; extract containing all the virtues of any thing, the adjective corresponding.

To me what is this *quintessence* of dust? man delights not me, nor woman neither. *Shakspeare*.

From their gross matter she abstracts the forms,  
And draws a kind of *quintessence* from things. *Davies*.

For I am a very dead thing,  
In whom love wrought new alchymy,  
For by his art he did express  
A *quintessence* even from nothingness,  
From dull privations and lean emptiness. *Donne*.

Venturous assertions as would have puzzled the authors to have made them good, specially considering that there is nothing contrary to the *quintessential* matter and circular figure of the heavens; so neither is there to the light thereof. *Hakewill*.

The ethereal *quintessence* of heaven  
Flew upward, spirited with various forms,  
That rolled orbicular and turned to stars. *Milton*.

Z



Paracelsus, by the help of an intense cold, teaches to separate the *quintessence* of wine. Boyle.

When the supreme faculties move regularly, the inferior passions and affections following, there arises a serenity and complacency upon the whole soul, infinitely beyond the greatest bodily pleasures, the highest *quintessence* and elixir of worldly delights.

South.

They made fire, air, earth and water, to be the four elements, of which all earthly things were compounded, and supposed the heavens to be a *quintessence* or fifth sort of body distinct from all these.

Watts's *Logick*.

QUINTILE, in astronomy, an aspect of the planets when they are 72° distant from one another, or a fifth part of the zodiac.

QUINTILIANS, a sect of ancient heretics, thus called from their prophetess Quintilia. In this sect the women were admitted to perform the sacerdotal and episcopal functions. They attributed extraordinary gifts to Eve, for having first eaten of the tree of knowledge. They added that Philip's four daughters, who were all prophetesses, were of their sect. In these assemblies the virgins entered in white robes, these personating prophetesses.

QUINTILIANUS, the father of the celebrated orator Marcus Quintilianus, was also an orator, and wrote many declamations. Ugolin of Parma published the first 136 in the fifteenth century; nine others were published in 1563 by Peter Ayraut, and afterwards by Peter Pithou in 1580. There have also been nineteen other declamations printed under the name of Quintilian the orator; but, in the opinion of Vossius, they were written neither by that orator nor his grandfather.

QUINTILIANUS (Marcus Fabius), a celebrated Latin orator, and the first critic of his age, was a native of Calagurris, or Calahorra, in Spain; and was the disciple of Domitius Afer, who died A. D. 59. He taught rhetoric at Rome for twenty years with great applause, and practised at the bar. Some imagine, with but little foundation, that he was consul; but it is certain that he was preceptor to the grandsons of Domitian's sister. There is still extant his excellent work, entitled *Institutiones Oratoriæ*, which is a treatise on rhetoric, in twelve books, justly admired. The work was found by Poggius in an old tower. There is also attributed to Quintilian a dialogue *De Causis corruptæ Eloquentiæ*; but it is more commonly ascribed to Tacitus.

QUINTIN, or QUINTAIN, *n. s.* Fr. *quintaine*. 'I know not whence derived.' Johnson.—Minsheu deduces it from Lat. *quintus*, and calls it a game celebrated every fifth year. Others trace it to Syr. *chanet*; Gr. *χοιρος*; which produced Lat. *contio quintana*. A tilting game. See QUINTAIN.

At *quintin* he,

In honour of his bridegates,  
Hath challenged either wide countess  
Come cut and long tail, for there be  
Six batchelors as bold as he,  
Adjuting to his company,  
And each one nath his livery. Ben Jonson.

QUINTIN MATSYS, also called the farrier of Antwerp, had been a blacksmith nearly twenty years; when, falling in love with a painter's daughter, who was very handsome, and disliked his trade, he betook himself to painting, in which

he made very uncommon progress. He was a diligent and careful imitator of ordinary life. His best known picture is that of the *Two Misers* in the gallery at Windsor. He died in 1529.

QUINTINIE (John De la), celebrated for his skill in horticulture, born at Poitiers in 1626. He was brought up to the law; and acquitted himself so well at the bar as to acquire the esteem of the chief magistrate. M. Tamboneau, president of the chamber of accounts, engaged him to undertake the preceptorship of his only son, which Quintinie executed to his satisfaction employing his leisure hours in the study of writers on agriculture. He gained fresh information with regard to his favorite pursuit by attending his pupil to Italy; for, all the gardens about Rome being open to him, he failed not to add practice to his theory. On his return to Paris M. Tamboneau gave up the management of his garden entirely to him; and Quintinie applied so closely to it that he became famous all over France. Louis XIV. erected a new office purposely for him, that of director of the royal fruit and kitchen gardens; and these gardens, while he lived, were the admiration of the curious. He twice visited London, and a paper of his was published in the *Philosophical Transactions*, on the culture of melons. In 1690 he published '*Instructions pour les Jardins Fruitiers et Potagers*,' which obtained great popularity, was frequently reprinted, and was translated into several modern languages. The last edition was the '*Parfait Jardinier*,' in 2 vols. 4to. The author died at Paris in the year 1700.

QUINTIUS FLAMINIUS, (Titus), a celebrated Roman general, who was consul A. U. C. 554. He acquired much military experience in the war against Hannibal; and was afterwards sent against Philip V. of Macedon, whom he totally defeated on the confines of Epirus, and made all Locris, Phocis, and Thessaly, tributary to Rome. Yet he not only granted peace to Philip, but proclaimed all Greece free and independent at the Isthmian games. This step rendered him very popular among the Greeks, and paved the way for the universal dominion of the Romans. He was afterwards sent to Prusias, king of Bithynia; who had given refuge to Hannibal, and by his address prevailed on the monarch to desert the greatest man of that age. Flaminius died suddenly.

QUINTUPLE, *adj.* Lat. *quintuplus*. Five-fold.

In the country, the greatest proportion of mortality, one hundred and fifty-six, is above *quintuple* unto twenty-eight the least.

Graunt's *Bills of Mortality*.

QUINTUS CALABER, a Greek poet, who wrote a large supplement to Homer's *Iliad*, in fourteen books, in which a relation is given of the Trojan war from the death of Hector to the destruction of Troy. He is supposed to have lived in the fifth century, but nothing certain can be collected either of his person or country. His poem was first made known by Cardinal Bessarion, who discovered it in St. Nicholas's church, near Otranto, in Calabria; whence the author was named Quintus Calaber. It was first published at Venice by Aldus.

**QUIP**, *n. s.* From *White*, to clean by rubbing, which see. A sharp jest; sarcasm.

*Quips*, and cranks, and wanton wiles,  
Nods, and becks, and wreathed smiles. *Milton.*

**QUIPOS**; a contrivance which supplied the place of writing among the Peruvians, at the time of the conquest of Peru by Pizarro, in the sixteenth century. It consisted of several threads of different colors attached to a cord, and tied in knots. Each color had its peculiar signification; and, if sense could not be conveyed by the colors, the knots were used. By this means calculations were carried on, enumerations of the population, historical documents and laws preserved, leagues and treaties indicated, &c. In each town there were officers whose duty it was to take care of the quipos. The defects of this species of writing were supplied by oral tradition and short poems. A similar contrivance was in use in Guiana.

**QUIRE**, *n. s. & v. n.* } Fr. *choeur*; Ital. *cho-*  
**QUIR'ISTER**. } *ro*. A body of singers;  
a chorus: the part of a church where the service  
is sung: to sing in concert: a chorister.

Myself have limed a bush for her.

And placed a *quire* of such enticing birds,  
That she will light to listen to their lays.

*Shakespeare.*

There's not the smallest orb which thou beholdest  
But in his motion like an angel sings,  
Still *quiring* to the young-eyed cherubims. *Id.*

I am all on fire,

Not all the buckets in a country *quire*  
Shall quench my rage. *Cleaveland.*

Begin the song, and strike the lively lyre.

Lo how the years to come, a numerous and well  
fitted *quire*,

All hand in hand do decently advance,  
And to my song with smooth and equal measures  
dance. *Cowley.*

At thy nativity a glorious *quire*

Of angels in the fields of Bethlehem sung  
To shepherds watching at their folds by night,  
And told them the Messiah now was born.

*Milton.*

As in beauty she surpassed the *quire*,  
So nobler than the rest was her attire. *Dryden.*

The fox obscene to gaping tombs retires,  
And wolves with howling fill the sacred *quires*.

*Pope.*

The coy *quiristers*, that lodge within  
Are prodigal of harmony. *Thomson's Spring.*

**QUIRE**, *n. s.* Fr. *quagur*, *cahir*; Ital. *quader-*  
*no*; Lat. *quaternio*. A bundle of paper contain-  
ing twenty-four sheets.

This operation is called parting, and is repeated  
two or three times for the best papers. The paper is  
now counted into *quires*, folded and packed up into  
reams for market. *Rees's Cyclopaedia.*

**QUIRIA**, a province of Immeretia, in Asia,  
on the shores of the Black Sea. It would appear  
to have been formerly flourishing. The residence  
of the prince is Titi Zighe, on the sea coast. The  
only considerable river is called Boas, passable  
for mules; but it is the custom for those who can  
afford it to be carried on men's backs, in a chair.  
Lat. 4° 26' N.

**QUIRINALIA**, in antiquity, a feast celebrated  
among the Romans in honor of Romulus.  
It was also called *stultorum feriae*, and was

celebrated on the 13th of the calends of March,  
our 17th of February.

**QUIRINI** (Angelo Maria), a learned cardinal,  
born in Venice in 1684. He was eminent as a  
philologist, historian, and antiquary. He was  
promoted to the cardinalate by Benedict XIII.  
He was a member of almost all the learned so-  
cieties in Europe; and wrote a great number of  
works. He died in 1755, and left his valuable  
library to the Vatican; to which an additional  
room was built to admit it.

**QUIRINUS**, the name given to Romulus  
after his deification.

**QUIRITES**, in Roman antiquity. In con-  
sequence of the agreement entered into by Ro-  
mulus and Tatius, king of the Sabines, Rome  
was to retain its name from Romulus; and the  
people were to be called Quirites, from Cures,  
the principal town of the Sabines, a name used  
in all public addresses to the Roman people.  
Dion. Hal. says that each particular citizen was  
to be called Romanus, and the collective body of  
them Quirites; yet it appears by this ancient  
form of words used at funerals, *Ollus Quiris*  
*letho datus est*, that each private citizen was also  
called Quiris. Quiris, according to Plutarch and  
others, signified, in the Sabine language, both a  
dart, and a warlike deity armed with a dart. This  
Quiris, or Quirinus, was either Mars or some  
other god of war; and the worship of Quiris con-  
tinued in Rome during the reign of Romulus;  
but after his death he was honored with the  
name Quirinus, and took the place of the god  
Quiris.

**QUIRK**, *n. s.* Of this word I can find no  
rational derivation.—Johnson. But see *QUEER*,  
and the Teut. *quirk*. Quick stroke; or fit;  
sharp saying; subtilty.

I've felt so many *quirks* of joy and grief,

That the first face of neither on the start,  
Can woman me unto't. *Shakespeare.*  
Some kind of men quarrel purposely on others to  
taste their valor; belike, this is a man of that *quirk*.

*Id.*

I may chance to have some odd *quirks* and rem-  
nants of wit broken on me. *Id.*

Most fortunately he hath achieved a maid,  
That paragon's description and wild fame,  
One that excels the *quirks* of blazoning pens. *Id.*  
Let a lawyer tell them he has spied some defect in  
an entail; how solicitous are they to repair that er-  
ror, and leave nothing to the mercy of a law *quirk*!

*Decay of Piety.*

There are a thousand *quirks* to avoid the stroke of  
the law. *L'Estrange's Fables.*

Now the chapel's silver bell you hear,

That summons you to all the pride of prayer;  
Light *quirks* of music, broken and uneven. *Pope.*

Conceits, puns, *quirks*, or quibbles, jests and re-  
partees may agreeably entertain, but have no place in  
the search after truth. *Watts on the Mind,*

**QUISQUALIS**, in botany, a genus of the  
monogynia order, and decandria class of plants;  
natural order thirty-first, *vepreculæ*: CAL. quin-  
quefid and filiform; petals five; FRUIT, a quin-  
queangular plum. One species only, *viz. Q.*  
*Indica*, a native of the Molucca Isles.

**QUIT**, *v. a.* } Fr. *quitter*; Ital.

**QUIT-RENT**, *n. s.* } *quetare*, *quietare*;

**QUIT-TANCE**, *n. s. & v. a.* } *barb. Lat. quittance.*

'To discharge an obligation; free; carry through; perform; repay; absolve; acquit; abandon; forsake; resign: a quit-rent is, a small reserved rent: quittance is, discharge from debt or obligation; recompense; repayment: to repay.

We will be *quit* of thine oath, which thou hast made us to swear. *Joshua ii. 20.*

He fair the knight saluted, louting low,  
Who fair him *quitted*, as that courteous was.

*Spenser.*

They both did fail of their purpose, and got not so much as to *quit* their charges; because truth, which is the secret of the most high God, whose proper handy-work all things are, cannot be compassed with that wit and those senses which are our own.

*Hooker.*

Enkindle all the sparks of nature,  
To *quit* this horrid act.

*Shakspeare. King Lear.*

Now I am remembered, he scorned at me!

But that's all one; omittance is no *quittance*. *Id.*

Mine eyes saw him in bloody state,  
Rend'ring faint *quittance*, wearied and out-breathed,  
To Henry Monmouth. *Id. Henry IV.*

Embrace me then this opportunity,  
As fitting best to *quittance* their deceit.

*Shakspeare.*

Nor further seek what their offences be,  
Guiltless I *quit*, guilty I set them free. *Fairfax.*

Far other plaints, tears, and laments,  
The time, the place, and our estates require,  
Think on thy sins, which man's old foe presents  
Before that judge that *quits* each soul his hire. *Id.*

For our reward,  
All our debts are paid; dangers of law  
Actions, decrees, judgments against us *quitted*.

*Ben Jonson.*

Never worthy prince a day did *quit*  
With greater hazard, and with more renown.

*Daniel.*

By this act, old tyrant,  
I shall be *quit* with thee. *Denham.*  
Thou art *quit* from a thousand calamities; therefore let thy joy, which should be as great for thy freedom from them as is thy sadness when thou feel'st any of them, do the same cure upon thy discontent. *Taylor.*

Samson hath *quit* himself  
Like Samson, and heroically hath finished  
A life heroic, on his enemies  
Fully revenged, hath left them years of mourning.

*Milton.*

One step higher  
Would set me highest, and in a moment *quit*  
The debt immense of endless gratitude. *Id.*

Iron works ought to be confined to certain places,  
where there is no conveyance for timber to places of  
vent, so as to *quit* the cost of the carriage. *Temple.*

Such a tax would be insensible, and pass but as a  
small *quit-rent*, which every one would be content to  
pay towards the guard of the seas. *Id.*

Still I shall hear and never *quit* the score,  
Stunned with hoarse Codrus' Theseid o'er and o'er.

*Dryden.*

Such variety of arguments only distract the understanding; such a superficial way of examining is to *quit* truth for appearance, only to serve our vanity.

*Locke.*

Does not the air feed the flame? and does not the  
flame at the same time warm and enlighten the air?  
and does not the earth *quit* scores with all the elements  
in the noble fruits that issue from it?

*South's Sermons.*

To John I owed great obligation;

But John, unhappily, thought fit

To publish it to all the nation;

Sure John and I are more than *quit*. *Prior.*

The prince, renowned in bounty as in arms,

With pity saw the ill-concealed distress,

*Quitted* his title to Campaspe's charms,

And gave the fair one to the friend's embrace. *Id.*

My old master, a little before his death, wished him joy of the estate which was falling to him, desiring him only to pay the gifts of charity he had left as *quit-rents* upon the estate. *Addison's Spectator.*

To *quit* you of this fear, you have already looked death in the face; what have you found so terrible in it? *Wake.*

QUIT-RENT (quietus redditus, i. e. quiet rent), is a certain small rent payable by the tenants of manors, in token of subjection, and by which the tenant goes quiet and free. In ancient records it is called white rent, because paid in silver money, to distinguish it from rent-corn, &c.

QUITCH'GRASS, *n. s.* Sax. *cpice.* Dog-grass.

They are the best corn to grow on grounds subject to *quitchgrass* or other weeds.

*Mortimer's Husbandry.*

QUITE, *adv.* From QUIT. Completely; perfectly; thoroughly.

He hath sold us, and *quite* devoured our money.

*Genesis xxxi.*

Those latter exclude not the former *quite* and clear as unnecessary. *Hooker.*

If some foreign ideas will offer themselves, reject them, and hinder them from running away with our thoughts *quite* from the subject in hand. *Locke.*

The same actions may be aimed at different ends, and arise from *quite* contrary principles. *Addison.*

QUITO, a presidency of Colombia, was originally an independent country, which remained distinct from all the neighbouring states, until a short time previous to the conquest of Peru by Francisco Pizarro; but its limits were not then exactly the same as at present. It is now bounded by Santa Fé on the north; on the east it extends to Maynas, Macas, and Quixos, which reach to the Portuguese frontiers; on the west the Great Pacific washes it from the gulf of Puna to the government of Atacames; and on the south the kingdom of Peru forms its boundary. Its length from north to south is about 600 miles, while its breadth exceeds 1800.

The chain of the Andes which pervades Quito, after having been divided near Popayan into three branches, unites in the district of Pastos, and stretches far beyond the equator. Its most lofty summits form two lines, separated by a series of valleys, from 10,600 to 13,900 feet in height, as far as the 3° of S. lat., in which the chief towns of Quito are situated. On the west side of this vale or plain rise the mountains of Casitagua, Pichincha, Atacazo, Corazon, Ilinissa, Carguirazo, Chimborazo, and Cunamhay; and on the east are the peaks of Cayambe, Guamani, Antisana, Passuchoa, Ruminari, Cotopaxi, Quelendama, Tunguragua, and cape Urcu, or the Altar—all of which, excepting three or four, are higher than Mont Blanc, but on account of the great elevation of the plain on which they rest, their appearance is not so lofty as may be imagined; the summit of Chimborazo

the most elevated, not being more than 11,959 feet above the plain of Tapia, which itself is 9481 feet above the level of the sea.

The temperature of the air is here so constant that the summits of those mountains which enter the region of perpetual snow have the line of congelation distinctly marked; and the road from Guayaquil to Quito leads along the northern declivity of Chimborazo, amid scenes of the most majestic nature, and near the regions of eternal frost. Chimborazo, the most lofty of the American summits, towers in the form of a dome over the conical peaks and heads of the adjacent mountains, to the altitude of 21,441 feet above the level of the sea. ПИЧИНЧА, which surmounts the city of Quito, was formerly a very active volcano; but since the conquest its eruptions have not been frequent. See that article. Humboldt supposes the bottom of the crater is on a level with the city of Quito. Its edges are always covered with snow; and flames rise from its surface amid columns of dark smoke.

But of all the American volcanoes Cotopaxi is the most noted. It is situated to the south-east of Quito, twelve leagues distant from that city, and five leagues north of Latacunga, between the mountains of Ruminavi, the summit of which is rugged and jagged with separate rocks, and Quelendama, whose peaks enter the regions of eternal frost. It has ejected such masses of scoria and immense pieces of rock, on the plain below, that they would of themselves, if heaped together, form an enormous mountain; and in a violent eruption in 1774 its roarings were heard at Honda, at the distance of 200 leagues. In 1768 it sent forth such a volume of ashes that the light of the sun was obscured at Hambato till three in the afternoon, and the people were forced to use lanterns; at the same time the cone was so heated that the mass of snow which covered it suddenly melted away; and at Guayaquil, 150 miles distant, its eruptions were audibly distinguished.

The volcano of Sangai, or Mecas, is the most southern mountain of Quito, and is covered with snow; but a continual fire issues from its summit, attended by explosions which are heard 120 miles distant, and when the wind is fair are audible even at Quito. The country adjacent to this volcano is totally barren, being covered with cinders. In this desert the river Sangay rises, and, joining the Upano, flows into the Marañon under the name of the Payra. Sangia is 17,131 feet above the level of the sea. The Altar, or El Altar, is on the eastern crest, in the district of Riobamba, joining itself by a high desert to another peak called Collanes. The Indians have a tradition that El Altar was formerly more lofty than Chimborazo, but that its summit suddenly fell in. By the latest observation it was found to be 17,256 feet above the level of the sea.

Tunguragua is seven leagues north of Riobamba. The figure of this volcanic mountain is conical, and very steep. Riobamba was destroyed by its dreadful eruptions. Some hot springs gush out through crevices in its sides, which has caused warm baths to be erected for the accommodation of invalids. Tunguragua is

16,500 feet above the level of the sea. Northwest of Riobamba is Carguirazo, which just enters the lower period of congelation. Near this mountain and Chimborazo is the road leading to Guayaquil, passing over such lofty deserts and such dangerous places, that many people perish in attempting to travel over it in bad weather, or in winter. The height of this mountain is 15,540 feet above the level of the sea.

In these mountainous regions the wind is often so violent that it tears off fragments of rocks. The French academicians, in measuring their oase, and taking the necessary angles, were often, it will be remembered, in danger of having their tents and huts blown over. In this immense extent the population, therefore, is chiefly confined to the valley, formed on the very ridge of the main chain of the Andes, by the parallel summits making a prolonged series of small narrow plains, extending from San Miguel de Ibarra to Loja, and to the country between those and Popayan, and from the western slope of the Cordillera to the ocean. The eastern governments are chiefly immense tracts, thinly scattered with missionary villages.

Quito Proper is subdivided from north to south into nine districts, viz. San Miguel de Ibarra, Otabalo, Quito, Latacunga, Riobamba, Chimbo, Guayaquil, Cuenca, and Loxa or Loja.

The jurisdiction of Quito contains, independently of the city, twenty-five villages, or parishes.

The lands are covered with plantations, in the plains, breaches or valleys, and up the sides of the mountains, as far as vegetation will reach, so as to be productive of any return to the cultivator. The valleys, being hot, grow sugar-canes and cotton; the plains, maize; and the higher regions, wheat, barley, &c. European grain was introduced into Quito by father Jose Rixi, a native of Ghent in Flanders, who sowed some near the convent of St. Francis; and the monks still show the vase in which the first wheat came from Europe, as a sacred relic. Above the regions which produce wheat, barley, potatoes, &c., are fed numerous flocks of sheep, which yield great quantities of wool; and cows are reared also in great numbers for the sake of cheese and butter. Most of the villages of Quito are inhabited by Indians.

The capital of this presidency is Quito. It is situated in long. 78° 10' 15" W., and lat. 0° 13' 27" S., on the eastern slope of the western branch of the equatorial Andes, thirty-five leagues distant from the coasts of the South Sea. The volcanic mountain Pichincha is the basis on which the celebrated city rests. Its crevices are so numerous in the environs that many of the suburban houses are built on arches; and from the acclivity of the ground the streets are very irregular and uneven. The city has in its vicinity the great plains Turubamba and Inna Quito, covered with country seats and cultivation; and the junction of these plains forms a neck of land, on which some of the streets are built. The height of Quito above the level of the sea is 9510 feet; and it is backed by the conical summit of Javirac, immediately under that of Pichincha,—Javirac being 10,239 feet above the ocean, consequently 729 feet higher than the city.

The temperature of the climate is such that neither heat nor cold is felt in extremes, though this may be experienced in a very short journey from it. The whole year is a perfect spring, with little or no variation; pleasant gales constantly waft the odors of the cultivated plains towards the town, and these are seldom known to fail or to become boisterous. The rain alone descends occasionally with impetuosity, and prevents the usual out-of-door avocations. With such a climate, and in the midst of plenty, the city is hourly liable to earthquakes, and its inhabitants are frequently occupied in noticing, with the most awful apprehensions, the slightest variations in the phenomena of the heavens; for from these they affect to judge of the approach of the subterraneous concussions which have so frequently destroyed the place. Of these a very destructive one was experienced in 1775. In 1797, on the 4th of February, the face of the whole district was changed, and in the space of a second 40,000 persons were hurled into eternity. During this tremendous scene the ground opened in all directions, and vomited out sulphur, mud, and water. This earthquake affected the temperature of the air, which is now commonly between 40° and 55°, whereas it was usually 66° or 68°; and since that time violent shocks have frequently been experienced.

Quito is plentifully supplied with water from several streams, which flow from the sides of the mountains, and are conducted into the town by means of conduits. Several of these brooks unite in one spot, and form the small river Machangara, which washes the south parts of the city, and is crossed by a stone bridge. The principal streets are all paved, and the houses are large and convenient, being mostly of one story in height, built of unburnt bricks and clay, and cemented by a sort of mortar which was made use of anciently by the Indians, and which becomes exceedingly solid. The principal square of Quito is ornamented with the cathedral, the bishop's palace, the town-hall, and the palace of the royal audience, and with a beautiful fountain in the centre. Four streets terminate at the angles of this square, which are broad, straight, and well built for about 400 yards, when the acclivities and breaches commence; on this account the luxury of wheel-carriages is not to be had. Besides the great square, there are two others of considerable size, and several small ones. In these are situate the churches and convents, which are generally fine buildings. The hospital is a fine structure; and there are several courts for the administration of justice, the exchequer, treasury, &c.

The population is estimated at 70,000 persons; among whom are many of high rank, descendants of the conquerors, or persons who came in the early periods from Spain. Notwithstanding the horror of earthquakes, and the constant state of anxiety they must feel, the inhabitants are gay, lively, and much addicted to pleasure, luxury, and amusement.

The clay and hot water vomited from the volcano diffuses much fertility in the vicinity, where a constant succession of fruits, flowers, and leaves appear during the whole year. Corn is

reaped and sown at the same time; and such is the goodness of the pasture that excellent mutton, beef, &c., are to be had here. Fine cheese is also made in the dairies, and so much is used, that 70,000 or 80,000 dollars' worth is annually consumed. Good butter is also found; and for the service of the table, whether in luxuries or necessities, nothing appears to be wanting.

In this province some cotton goods are manufactured. These are exported to Peru; for which gold, silver, laces, wine, brandy, oil, copper, tin, lead, and quicksilver, are returned. The wheat of Quito is exported to Guayaquil; and the coast of Guatemala sends indigo, iron, and steel, for which some of the products of Quito are returned by way of Guayaquil. The commerce of Quito is, however, mostly internal; and this province contains no metallic veins which are worked, though many rich ones are supposed to exist; and some mercury has been found between the villages of Cuenca and Azogue.

Quito is celebrated as having been the scene of the measurement of a degree of the meridian by the French and Spanish mathematicians, in the reign of Louis XV. The plain made choice of for the mensuration of the great base is 1592 feet lower than the city of Quito, and four leagues north-east of it, near the village Yuranqui, from which it has its name. It was in this desert valley, surrounded by the lofty summits of the central Andes, that these operations were carried on. In the church of the Jesuits is an alabaster slab, on which is engraven a Latin inscription, commemorating these labors, and enumerating the signals, angles, and other circumstances connected with the measurement performed in those years.

QUITTER-BONE. See VETERINARY ART: 'QUIVER, *n. s.* Goth. *koja, kofe*; Lat. *cavea*.

Corrupted from Fr. *couvrir*, or cover. A case or sheath for arrows.

As arrows are in the hand of a mighty man; so are children of the youth. Happy is the man that hath his quiver full of them. *Psalms cxxvii. 5.*

As Dianne hunted on a day.

She chanced to come where Cupid lay,

His quiver by his head.

*Sponser.*

Those works, with ease as much he did,

As you would ope and shut your quiver-lid.

*Chapman.*

Diana's nymphs would be arrayed in white, their arms and shoulders naked, bows in their hands, and quivers by their sides.

*Peacham on Drawing.*

'Tis chastity:

She that has that, is clad in compleat steel,

And like a quivered nymph with arrows keen,

May trace huge forests and unharboured heaths,

Infamous hills, and perilous sandy wilds. *Milton.*

Her sounding quiver on her shoulder tied,

One hand a dart, and one a bow supplied. *Dryden.*

The thousand loves that arm thy potent eye,  
Must drop their quivers, flag their wings and die.

*Prior.*

From him whose quills stand quivered in his ear,  
To him who notches sticks at Westminster. *Pope.*

QUIVER, *v. n. & adj.* Wel. *chwyffwr*; Span. *quebar*, or perhaps from quake. To quake; shiver; play with a tremulous motion: quick in motion; nimble.

When I heard, my belly trembled; my lips quivered at the voice. *Hab. iii. 16.*

Zelmae would have put to her helping hand, but she was taken with such a *quivering*, that she thought it more wisdom to lean herself to a tree and look on.

*Sidney.*

The birds chaunt melody on every bush,  
The green leaves *quicker* with the cooling wind.

*Shakespeare.*

There was a little *quiver* fellow, and he would manage you his piece thus; and he would about and about.

*Id.*

O'er the pommel cast the knight,  
Forward he flew, and pitching on his head,  
He *quicker* with his feet, and lay for dead.

*Dryden.*

With what a spring his furious soul broke loose,  
And left the limbs still *quivering* on the ground.

*Addison.*

Eurydice with *quie'ring* voice he mourned,  
And Heber's banks Eurydice returned.

*Gay.*

Dancing sun-beams on the waters played,  
And verdant alders formed a *quie'ring* shade.

*Pope.*

The dying gales that pant upon the trees,  
The lakes that *quiver* to the curling breeze.

*Id.*

**QUIXOS AND MACAS**, the most easterly province of the audience of Quito, is bounded on the north by Popayan and the plains; east by Portuguese Guiana; on the west it is separated from Latacunga and Ibarra by the Cordilleras of Cotopaxi, Cayambe, &c.; and on the south it is limited by Maynas and Bracamoros. It is extremely mountainous, full of ravines, and abounding in rivers, some of which are very large, and all running into the Maranon. Impassable, except on foot, it was traversed by the missionaries, who, at the expense of great labors and fatigues, entered Mainas. Its temperature is cold, but it produces much cotton and fine tobacco; the valleys and ravines are extremely fertile. In the south-west of Quixos is Los Canelos, a sort of spice resembling cinnamon growing there. The south part of Quixos is called Macas, and is separated into a distinct district, under that appellation, of which the chief town is Macas, or Sevilla de Oro.

**QUODLIBET**, *n. s.* Lat. *quod-libet*. A nice point; a subtilty.

He who reading on the heart,

When all his *quodlibets* of art

Could not expound its pulse and heat,

Swore, he had never felt it beat.

*Prior.*

**QUOJA**, a country of Africa, at the back of Sierra Leone, between 8° and 10° of W. long., and between 6° and 9° of N. lat. It is well cultivated, but has little trade. The monarch is despotic, and his nobles enjoy extraordinary respect. On the tombs of their masters, slaves are frequently sacrificed, and numerous subjects on that of the king.

**QUOIF**, *n. s. & v. a.* } Fr. *coeffe*. Any cap  
**QUOIFURE**. } with which the head is covered: to dress with a cap: *quoiffure* is, head-dress. See **COIF**.

Hence, thou sickly *quoif*,

Thou art a guard too wanton for the head,

Which princes, flushed with conquest, aim to hit.

*Shakespeare.*

She is always *quoiffed* with the head of an elephant, to shew that this animal is the breed of that country.

*Addison.*

The lady in the next medal is very particular in her *quoiffure*.

*Id. on Medals.*

**QUOIN**, *n. s.* Fr. *coin*. A corner; a wedge.

A sudden tempest from the desert flew  
With horrid wings, and thundered as it blew,  
Then, whirling round, the *quoins* together shook.

*Sandys.*

Build brick houses with strong and firm *quoins* or columns at each end.

*Mortimer's Husbandry.*

**QUOIN**, or **CORN**, on board a ship, a wedge fastened on the deck, close to the breach of the carriage of a gun, to keep it firm up to the ship's side. Cantic *quoins* are short three legged *quoins* put between casks to keep them steady.

**QUOINS**, in architecture, denote the corners of brick or stone walls. The word is particularly used for the stones in the corners of brick buildings. When these stand out beyond the brick-work, their edges being chamfred off, they are called rustic *quoins*.

**QUOIT**, *n. s., v. n. & v. a.* Belg. *coete, goedd*, thrown. Something thrown at a certain point or mark: to play at *quoits* or the *discus*; to throw.

He plays at *quoits* well. *Shakspeare. Henry IV.*

*Quoit* him down, Bardolf, like a shove-groat shilling.

*Shakspeare.*

Noble youths for mastership would strive,  
To *quoit*, to run, and steeds and chariots drive.

*Dryden.*

When he played at *quoits*, he was allowed his breeches and stockings.

*Arbutnot and Pope.*

**QUON'DAM**. Lat. *quondam*. Having been formerly. A ludicrous word.

This is the *quondam* king, let's seize upon him.

*Shakspeare.*

What lands and lordships for their owner know  
My *quondam* barber, but his worship now.

*Dryden.*

**QUOOK**. Preterite of quake. Obsolete.

Freely up those royal spoils he took,

Yet at the lion's skin he inly *quook*.

*Spenser.*

**QUORUM**, *n. s.* Lat. *quorum*. A bench of justices; such a number of officers as is sufficient to do business.

They were a parcel of mummings, and being himself one of the *quorum* in his own county, he wondered that none of the Middlesex justices took care to lay some of them by the heels.

*Addison.*

**QUORUM** is often mentioned in English statutes, and in commissions of justices of the peace and others. It is thus called from the words of the commission, *quorum A. B. unum esse volumus*: —e. g. where a commission is directed to seven persons, or to any three of them, whereof A. B. and C. D. are to be two; in this case, they are said to be of the *quorum*, because the rest cannot proceed without them; so a justice of the peace and *quorum* is one without whom the rest of the justices in some cases cannot proceed.

**QUOTA**, *n. s.* Lat. *quotus*. A share; an assigned proportion.

Scarce one in this list but engages to supply a *quota* of brisk young fellows, equip with hats and feathers.

*Addison.*

**QUOTE'**, *v. a.* } Fr. *quoter*; Ital. and Lat.

**QUOTA'TION**, } *costa*, a marginal note. To

**QUO'TER**. } cite an author or passage of an author; adduce the words of another by way of authority.

The second chapter to the Romans is here *quoted* only to paint the margent.

*Whitgift.*

St. Paul *quotes* one of their poets for this saying.

*Sillingleet.*

He, that has but ever so little examined the citations of writers, cannot doubt how little credit the quotations deserve, where the originals are wanting.

*Locke.*

He ranged his tropes, and preached up patience,  
Backed his opinion with quotations.

*Prior.*

He *quoted* texts right upon our Saviour, though he expounded them wrong.

*Atterbury.*

I proposed this passage entire, to take off the disguise which its *quoter* put upon it.

*Id.*

He will, in the middle of a session, *quote* passages out of Plato and Pindar.

*Swift's Miscellanies.*  
Some for renown on scraps of learning dote,  
And think they grow immortal as they *quote*,

To patchwork learned quotations are allied,  
Both strive to make our poverty our pride.

*Young.*

*Quotation*, sir, is a good thing; there is a community of mind in it: classical quotation is the parole of literary men all over the world.

*Johnson.*

**QUOTH**, *verb imperfect*. The only part of Sax. *croþan*; Teut. *queden*, to say, retained in English, and now only used in ludicrous language. It is used by Sidney irregularly in the second person. Quoth I, means, say I, or said I: quoth he, says he, or said he.

Enjoying, *quoth* you.

*Sidney.*

Shall we, *quoth* he, so basely brook

This paltry ass?

*Hudibras.*

**QUOTIDIAN**, *adj. & n. s.* Fr. *quotidien*; Lat. *quotidianus*. Daily; happening every day; a fever returning daily.

If I could meet that fancymonger, I would give

him counsel; for he seems to have the *quotidian* love.

*Shakspeare.*

*Quotidian* things, and equidistant hence  
Shut him for man in one circumference.

*Donne.*

Nor was this a short fit of shaking, as an ague,  
but a *quotidian* fever, always increasing to higher inflammation.

*King Charles.*

**QUOTIENT**, *n. s.* French *quotient*; Latin *quoties*. The resulting sum in division.

In arithmetick, *quotient* is the number produced by the division of the two given numbers the one by the other.

*Cocher.*

To make all the steps belonging to the same pair of stairs of an equal height, they consider the height of the room in feet and inches, and multiply the feet by twelve, whose product, with the number of odd inches, gives the sum of the whole height in inches, which sum they divide by the number of steps they intend to have in that height, and the *quotient* shall be the number of inches and parts that each step shall be high.

*Moxon.*

**QUO-WARRANTO**, in law, a writ which lies against a person or corporation that usurps any franchise or liberty against the king, in order to oblige them to show by what right and title he claims such franchise. This writ also lies for mis-user or non-user of privileges granted. The attorney-general may exhibit a quo-warranto in the crown office against any particular persons, or bodies politic or corporate, who use any franchise or privilege without having a legal grant or prescription for the same; and a judgment obtained upon it is final, as being a writ of right.

## R.

R is called the canine letter, because it is uttered with some resemblance to the growl or snarl of a cur; it has one constant sound in English; as, red, rose, more, muriatic; in words derived from the Greek, it is followed by an *h*, as rhapsody: *r* is never mute, unless the second *r* may be accounted mute, where two are used; as myrrh. R is a liquid consonant, being the seventeenth letter of our alphabet. Its sound is formed by a guttural extrusion of the breath vibrated through the mouth, with a sort of quivering motion of the tongue, drawn from the teeth and canulated with the tip a little elevated towards the palate. When not aspirated, it is always followed by a vowel at the beginning of words and syllables. R would seem to have a softer sound among the ancient Romans than among us, by its being frequently interposed to prevent the clashing of vowels; as in *rarus*, *apaucos*, *nurus* from *νυρος*, *murex* from *μυραξ*, *mus muris* from *μυς μυρος*; for Hetrusci they frequently wrote Thusci, and even Tuscii; and for *sursum susum*; *prorsus*, *prosus*. In fact there was that similarity between the sound of the *s* and *r*, that, as the Romans avoided the doubling of their consonants, they dropped the *r* in such words; the *s* supplying the place of both. Hence too it came to pass that, what they at first pronounced *asa*, *asena*, *casmen*, was afterwards *ara*, *arena*, *carmen*; and those first

named *Fusii* and *Valesii* were afterwards called *Furii* and *Valerii*. Cicero tells us, the *Papirii* were first called *Papisii*; and even fixes the time when the change was made, viz. in the year of Rome 415.

From the same softness of the sound of the *r*, it came to be used indifferently with the *l*, in many words; e. gr. *Latiarius* and *Latialis*, *Palilia* and *Parilia*, &c.; but it still more frequently degenerated into *l*; thus *remures* became changed into *lemures*; *interlego*, *perluceo*, into *intellego* and *pelluceo*; *frater* into *fratellus*, &c. As an abbreviation, in the notes of the ancients, R. or RO. signifies *Roma*; R. C. *Romana civitas*. See ABBREVIATION. In the prescriptions of physicians, R. stands for *recipe*, i. e. take. As a numeral, R. anciently stood for eighty; and with a dash over it, thus  $\bar{R}$ , for 80,000; but the Greek  $\rho$ , with a small mark over it, signified 100; with the same mark under it denoted  $1000 \times 100$ ; thus  $\rho$ , signified 100,000. In the Hebrew numeration  $\aleph$  denoted 200; and with two horizontal points over it  $\aleph$  denoted  $1000 \times 200$ ; thus  $\aleph$  = 200,000.

RAAB, a country of Hungary, on the Danube and Raab rivers, has an area of 600 square miles, with 78,000 inhabitants, of whom about 1000 are Jews. It contains a number of hills, on which

vine, are the culture, and produces corn and pasture.

RAAB, GYOR, or Nagy-Gyor, the capital, is a considerable town, situated in a fine plain, and nearly surrounded by the Danube, the Raab, and the Ilabnitz. It is fortified by nature and art; and has a large glacis and open space between the town and the suburbs. Most of the houses are of stone, and some of them very handsome. It is a bishop's see, and contains 11,000 inhabitants. The chief manufacture is cutlery, particularly knives and swords. A theological academy was erected here in 1750; here also the Lutherans have a college. Raab was a place of strength in the time of the Romans; but the present fortifications are modern. In the sixteenth and seventeenth centuries, when the Turks advanced into Hungary, it fell for a time into their hands and sustained a siege of some length from the French in 1809. Thirty-eight miles S. S. E. of Presburg; and sixty-six E. S. E. of Vienna.

RAAMSES, an ancient town of Egypt, said to have been built in the time of Joseph's ministry, as one of Pharaoh's store-houses.

RAASAY, or RAAZA, one of the Hebrides, lying between the mainland of Scotland and Skye, from which it is separated by a narrow sound. It is a rough, rocky, and indifferently fruitful island, with bold and dangerous shores, fifteen miles long by about two broad, and containing thirty-one square miles and a half. The west coast rises to a great height above the sea. Near the south end of it is Dunlan, a lofty hill, whence many rivulets descend.

RABATE, *v. n.* } Fr. *rabattre, rabat,*

RABA'TO, *n. s.* } *rabater*; Ital. *rabato.*

RAB'BET, *v. a. & n. s.* } To reduce; bring down; particularly to bring down or recover a hawk to the fist: the rabato is the old folding down collar of a shirt or shift: to rabbet, among carpenters, is to reduce or pare down wood so as to make a joint; and as a noun substantive the joint so made. In ship-carpentry, it signifies the letting in of the planks of the ship into the keel.

I think your other *rabato* were better. *Shakspeare.*

They set the *rabbets* of the door within the *rabbets* of the door post. *Moxen.*

RAB'BI, *n. s.* } Heb. רַבִּי. A doctor among  
RAB'BIN. } the Jews.

Be not ye called *rabbi*; for one is your master, even Christ, and all ye are brethren.

*Mat. xxiii. 18.*

The Hebrew *rabbins* say that nature hath given man, for the pronouncing of all letters, the lips, the teeth, the tongue, the palate, and throat.

*Camden's Remains.*

RABBIN, or RABBI, was a title which the doctors of the law among the Jews assumed, and literally signifies masters or excellents. There were several gradations before they arrived at the dignity of a rabbin; which was not conferred till they had acquired the profoundest knowledge of the law and the traditions. It does not, however, appear that there was any fixed age or previous examination necessary; but when a man had distinguished himself by his skill in the written and oral law, and passed through the

subordinate degrees, he was saluted a rabbin by the public voice. Among the modern Jews, the learned men retain no other title than that of rabbi or rabbins; they have great respect paid them, have the first places or seats in their synagogues, determine all matters of controversy, and frequently pronounce upon civil affairs: they have even power to excommunicate the disobedient.

RABBINISTS, among the modern Jews, an appellation given to the doctrine of the rabbins concerning traditions, in opposition to the Caraites; who reject all traditions. See KARAITES.

RAB'BIT, *n. s.* Belg. *robbe*; Swed. *rof*; of Goth. *rauf* (also a pole). An animal that lives on plants, and burrows in the ground.

I knew a wench married, as she went to the garden for parsley to stuff a *rabbit*. *Shakspeare.*

A company of scholars going to catch conies, carried one with them which had not much wit, and gave in charge that, if he saw any, he should be silent for fear of scaring of them; but he no sooner espied a company of *rabbits*, but he cried aloud, ecce multi cuniculi; which he no sooner said, but the conies ran to their burrows; and he, being checked by them for it, answered, Who would have thought that the *rabbits* understood Latin? *Bacon.*

RABBIT, in zoology. See LEPUS. The buck rabbits will kill the young ones if they can get at them; and the does in the warrens prevent this by covering their stocks, or nests, with gravel or earth, which they close so artificially up with the hinder part of their bodies, that it is hard to find them out. They never suckle their young ones at any other time than early in the morning, and late at night: and always, for eight or ten days, close up the hole at the mouth of the nest, in this careful manner when they go out. After this they begin to leave a small opening, which they increase by degrees; till at length, when they are about three weeks old, the mouth of the hole is left wholly open that they may go out, as they are then big enough to take care of themselves. Those who keep rabbits, breed them in hutches; but these must be kept very neat and clean, else they will be always subject to diseases. Care must be taken also to keep the bucks and does apart till the latter have just kindled; when they are to be turned to the bucks. In choosing tame rabbits, pick the largest and fairest; particularly the silver-haired ones, which sell better than any other. Their food may be colewort and cabbage leaves, carrots, parsnips, apple rinds, green corn, and vetches; also vine leaves, grass, fruits, oats, and oat-meal, milk thistles, sow thistles, and the like; but with these moist foods they must have a proportionable quantity of dry food, as hay, bread, oats, bran, &c., else they will grow pot-bellied, and die. Bran and grains mixed together are proper. In winter they will eat hay, oats, and chaff, and these may be given them three times a day; but, when they eat green things, they must not drink at all, else they will fall into a dropsy. At all other times little drink may be allowed, but it must always be fresh. When any green herbs or grass are cut for their food, care must be taken that there be no hemlock among it; as



it is poison to them. Rabbits are subject to two diseases; 1st, the rot, which is caused by too large a quantity of greens, or from giving them fresh gathered and wet with dew or rain. The greens therefore are always to be given dry; and a sufficient quantity of dry food mixed with them: the best food is the shortest and sweetest hay that can be got, of which one load will serve 200 couples a year; and, out of this stock of 200, 200 may be eaten in the family, 200 sold, and a sufficient number kept for breeding. The other disease is a sort of madness: this may be known by their wallowing and tumbling about with their heels upwards, and hopping in any odd manner into their boxes. This distemper is supposed to be owing to the rankness of their feeding; and the general cure is the keeping them low, and giving them the prickly herb called tare-thistle to eat. The general computation of males and females is, that one buck rabbit will serve for nine does; some allow ten to one buck. The wild rabbits are either to be taken by small cur dogs, or by spaniels bred up to the sport; and the places of hunting those who straggle from their burrows is under close hedges or bushes, or among corn fields and fresh pastures. The owners use to course them with small greyhounds. The common method is by nets called *purse nets*, and ferrets. The ferret is sent into the hole to fetch them out; but the purse net, being spread over the hole, takes them as they come out. The ferret's mouth must be muffled, and then the rabbit gets no harm. A hay net or two may also be put up at a small distance from the burrows that are to be hunted; thus very few will escape. Some who have not ferrets smoke the rabbits out of their holes with burning brimstone and orpiment; but this is very detrimental to the place, as no rabbit will for a long time afterwards come near it. See WARREN.

RAB'BLE, *n. s.* } Lat. *rabula*; barb. Lat.  
RAB'LEMENT. } *rabulari*; French *racaille*;  
Belg. *rapalje*, *rabbelan*. A tumultuous crowd;  
an assembly of low people; both nouns are thus  
applied.

A rude *rabblement*,  
Whose like he never saw, he durst not bide,  
But got his ready steed, and fast away 'gan ride,  
*Spenser.*

Countrymen will ye relent and yield to mercy,  
Or let a *rabble* lead ye to your deaths? *Shakespeare.*

Go bring the *rabble* here to this place. *Id.*  
The *rabblement* hooted, clapped their chopt hands,  
and uttered a deal of stinking breath. *Id.*

Of these his several ravishments, betrayings, and  
stealing away of men's wives, came in all those an-  
cient fables, and all that *rabble* of Grecian forgeries.  
*Raleigh.*

There will be always tyrants, murderers, thieves,  
traitors, and other of the same *rabblement*. *Camden.*

There is a *rabble* amongst the gentry, as well as  
the commonalty, a sort of plebeian heads, whose  
faucy moves with the same wheel as these men.  
*Sir T. Browne.*

The better sort abhors scurrility,  
And often censures what the *rabble* like. *Roscommon.*

That profane, atheistical, epicurean *rabble*, whom  
the whole nation so rings of, are not the wisest men  
in the world. *South.*

To gratify the barbarous audience, I gave them a  
short *rabble* scene, because the mob are represented by

Plutarch and Polybius with the same characters of  
baseness and cowardice. *Dryden.*

His enemies have only been able to make ill  
impressions upon the low and ignorant *rabble*, and to  
put the dregs of the people in a ferment.

*Addison's Freeholders.*

RABELAIS (Francis), a French writer of the  
sixteenth century, was born at Chinon, in Tou-  
raine about 1483. He was first a Franciscan  
friar, but quitting his religious habit studied phy-  
sician at Montpellier, where he took his degree of  
M. D. Some time after he came to Rome as  
physician in ordinary to cardinal John du Bel-  
lay, archbishop of Paris. On a second journey  
to Rome, he obtained, in 1536, a brief to qualify  
him for holding ecclesiastical benefices; and, by  
the interest of cardinal Du Bellay, was received  
as a canon in the abbey of St. Maur, near Paris.  
His knowledge in physic rendered him doubly  
useful; but, as he was a man of wit and humor,  
many ridiculous things are reported of him. He  
published several works; but his chief perform-  
ance is a strange incoherent romance, called the  
History of Gargantua and Pantagruel, a satire.  
He died about 1553.

RAB'ID, *adj.* Lat. *rabidus*. Fierce; furious;  
mad.

A woman had her coat torn by a mad dog, which  
she a considerable time after sewed up, and bit off  
the thread with her teeth, and some time after died  
*rabid* from biting off that thread. (Hildanus Obs.  
Chir.) Also a man only kissing his children to take  
his leave of them when he had the *rabies* upon him,  
they all soon after died *rabid*.

*Diseases of Barbadoes, p. 249.*

RABIRIUS (Caius), a Roman knight, who  
lent an immense sum of money to Ptolemy Au-  
letes, king of Egypt. The monarch afterwards  
not only refused to repay him, but confined him,  
and endangered his life. Rabirius escaped from  
Egypt with difficulty; but, on his return to Rome,  
he was accused by the senate of having lent mo-  
ney to an African prince for unlawful purposes.  
He was ably defended by Cicero, and acquitted  
with difficulty.

RABIRIUS, a Roman poet in the age of Augus-  
tus. He wrote a poem on the victory over An-  
tony at Actium. Seneca has compared him to  
Virgil for elegance and majesty; but Quintilian  
does not speak so favorably of him.

RABIRIUS, an architect in the reign of Domi-  
tian. He built a celebrated palace for the em-  
peror, of which the ruins are still seen at Rome.

RABNABAD, a low island in the bay of  
Bengal, formed by the debris of the river Ganges,  
and separated from the mainland by a narrow  
strait. It is fifteen miles in length, by five in  
breadth, and is covered with long grass and un-  
derwood, the habitation of deer and tigers. It  
is nearly inundated during the spring tides; and  
is not inhabited. Long. 90° 26' E., lat. 22° N.

RACE, *n. s.* Fr. *race*; Span. *raça*; Ital. *razza*,  
of Lat. *radix*, a root. A family; course of gene-  
rations; particular breed: also used for a taste of  
the root; hence a strong taste or flavor. See the  
extract from Temple, and RACY.

A *race* of youthful and unhandled colts,  
Fetching mad bounds.

*Shakespeare. Merchant of Venice. 1*



RAPHAEL L.



RABELAIS.



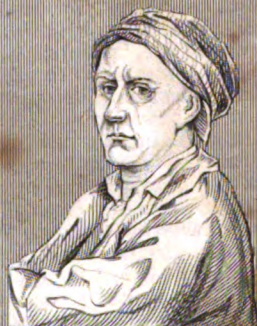
ST. J. REYNOLDS.



QUARLES.



ST. W. RALEIGH.



RAYNAL.



RACINE.



RADCLIFFE.



P. RAPIN.



The *race* of mules, fit for the plough is bred.

*Chapman.*

Of gardens there may be forms wholly irregular, that may have more beauty than of others; but they must owe it to some extraordinary dispositions of nature in the seat, or some great *race* of fancy or judgment in contrivance.

*Temple.*

He in a moment will create

Another world; out of man, a *race*

Of men innumerable, there to dwell. *Milton.*

Male he created thee, but thy consort

Female for *race*. *Id.*

Instead

Of spirits malign, a better *race* to bring  
Into their vacant room. *Id.*

High as the mother of the gods in place,  
And proud like her of an immortal *race*.

*Dryden.*

Hence the long *race* of Alban fathers come. *Id.*

In the *races* of mankind, and families of the world, there remains not to one above another the least pretence to have the right of inheritance.

*Locke.*

If they are all debased and willing slaves,  
The young but breathing to grow grey in bondage,  
And the old sinking to ignoble graves,  
Of such a *race* no matter who is king. *Murphy.*

RACE, *n. s. & v. n.* } Sax. *ræf*; Goth. Swed.  
RACE-HORSE, } and Isl. *ras*, of *rans*, *ren-*  
RA' CER. } *na*, to run.—Thomson.

Contest in running; match between running animals; course on the feet; progress; train: to run in a *race*: a *race*-horse or *racer* is a horse thus used: the latter is also applied to any animal that runs a *race*.

It suddenly fell from an excess of favour, which many examples have taught them never stopt his *race* till it came to a headlong overthrow. *Sidney.*

The flight of many birds is swifter than the *race* of many beasts. *Bacon.*

An offensive war is made, which is unjust in the aggressor; the prosecution and *race* of the war carrieth the defendant to invade the ancient patrimony of the first aggressor, who is now turned defendant; shall he sit down, and not put himself in defence? *Id.*

The *race* of this war fell upon the loss of Urbin, which he reobtained. *Id.*

To describe *races* and games  
Of tilting furniture. *Milton.*

My *race* of glory run, and *race* of shame. *Id.*

The great light of day yet wants to run  
Much of his *race* though steep. *Id.*

The reason Hudibras gives, why those who can talk on trifles speak with the greatest fluency, is, that the tongue is like a *race*-horse, which runs the faster the less weight it carries. *Addison.*

Stand forth ye champions, who the gauntlet wield,  
Or you, the swiftest *racers* of the field;  
Stand forth, ye wrestlers, who these pastimes grace,  
I wield the gauntlet, and I run the *race*. *Pope.*

A poet's form she placed before their eyes,  
And bad the nimblest *racer* seize the prize. *Id.*

He safe returned, the *race* of glory past,  
New to his friends' embrace. *Id. Odyssey.*

For every horse, mare, or gelding, *bonà* side, kept for the purpose of *rac*ing or running for any plate, prize, or sum of money, or other thing, or kept in training for any of the said purposes, whether in the stables of the proprietor or proprietors, or of any other person or persons, the sum of 2*l.* 8*s.*

45 *Geo. III. c. 13.*

A poet hurts himself by writing prose, as a *race*-horse hurts his motions by condescending to draw in a team. *Shenstone.*

Away went Gilpin—who but he!

His fame soon spread around,

He carries weight! he rides a *race*!

'Tis for a thousand pound!

*Compo.*

RACE, in general, signifies running with others in order to obtain a prize, either on foot, or on horseback, in chariots, &c. The *race* was one of the exercises among the ancient Grecian games, which was performed in a course containing 125 paces; and those who contended in these foot races were frequently clothed in armour. Chariot and horse races also made a part of these ancient games. Races were known in England in very early times. Fitz-Stephen, who wrote in the days of Henry II., mentions the great delight that the citizens of London took in the diversion, from a generous emulation of showing superior skill in horsemanship. Races appear to have been in vogue in the reign of queen Elizabeth, and to have been carried to such excess as to injure the fortunes of the nobility, though it is probable that the parsimonious queen did not approve of it. In king James's reign places were allotted for the sport: Croydon in the south, and Garterly in Yorkshire, were celebrated courses. Camden also says, that in 1607 there were races near York, and the prize was a little golden bell.

RACE-HORSES. In preparing the *race*-horse for running, it is first necessary to examine whether he be low or high in flesh; and whether he be dull and heavy, or brisk and lively abroad. If he appear dull and heavy, and there is reason to suppose it is owing to too hard riding, or, as the jockeys express it, to some grease that has been dissolved in hunting, and has not been removed by scouring, then the proper remedy is half an ounce of diapente given in a pint of good sack; this will at once remove the cause, and revive the animal's spirits. After this, for the first week, he is fed with oats, bread, and split beans; giving him sometimes the one, and sometimes the other as he likes best; and always leaving some in the locker, that he may feed at leisure when left alone. When the groom returns at the feeding time, whatever is left of this must be removed and fresh given; thus he will soon become high spirited, wanton, and playful. Every day he must be rode out an airing, and every other day it will be proper to give him a little more exercise; but not so much as to make him sweat much. The beans and oats in this case are to be put into a bag, and beaten till the hulls are all off, and then winnowed clean; and the bread is to have the crust clean cut off. If the horse be in good flesh and spirits when taken up for its month's preparation, the diapente must be omitted; and the chief business will be to give him good food, and so much exercise as will keep him in wind, without oversweating him or exhausting his spirit. When he takes large exercises afterwards, towards the end of the month, it will be proper to have some horses in the place to run against him. This will put him upon his mettle, and the beating them will give him spirits. This, however, is to be cautiously observed, that he has not a bloody heat given him for ten days or a fortnight before the plate is to be run for; and that the last heat that is given him the day before the *race*, must be in his clothes: this

will make him run with much more vigor when stripped for the race, and feeling the cold wind on every part. In the second week he should have the same food, and more exercise. In the last fortnight he must have dried oats, that have been hulled by beating. After this they are to be wetted in a quantity of whites of eggs, beaten up, and then laid out in the sun to dry; and when dry, as before, the horse is to have them. This sort of food is very light of digestion, and very good for his wind. The beans this time should be given more sparingly, and the bread should be made of three parts wheat and one part beans. If he should become costive under this course, he must then have some ale and whites of eggs beaten together; this will cool him, and keep his body moist. In the last week the mash is to be omitted, and barley water given him in its place: every day, till the day before the race, he should have his fill of hay; then he must have it given him more sparingly, that he may have time to digest it; and in the morning of the race-day he must have a toast or two of white bread soaked in sack, and the same just before he is let out to the field. This is an excellent method, because the two extremes of fullness and fasting are at this time to be equally avoided; the one hurting his wind, and the other occasioning faintness. After he has had his food, the litter is to be shaken up, and the stable kept quiet, that he may be disturbed by nothing till he is taken out to run.

The amusement of horse-racing gradually obtained its present celebrity. In 1599 private matches between gentlemen, who were their own jockeys and riders, were very common; and, in the reign of James I., public races were established at various places, when the discipline and mode of preparing the horses for running, &c., were much the same as now. The most celebrated races of that time were called bell courses, the prize of the conqueror being a bell: hence, perhaps, the phrase of bearing the bell, applied to excellence. In the end of Charles I.'s reign, races were performed in Hyde Park. Newmarket was also a place for the same purpose, though it was first used for hunting. Racing was revived soon after the Restoration, and much encouraged by Charles II., who appointed races for his own amusement at Datchet Mead, when he resided at Windsor. Newmarket, however, became the principal place. The king attended in person, established a house for his own accommodation, and entered horses in his own name. Instead of bells, he gave a silver bowl or cup, value 100 guineas; on which prize the exploits and pedigree of the successful horse were generally engraved. William III. added to the plates, and founded an academy for riding: and queen Anne continued the bounty, adding several plates herself. George I., towards the end of his reign, discontinued the plates, and gave in their room 100 guineas. An act was passed in the 13th of George II. for suppressing races by ponies and other small and weak horses, &c., by which all matches for any prize under the value of £50 are prohibited, under a penalty of £200 to be paid by the owner of each horse running, and £100 by such as advertise the plate; and by

which each horse entered to run, if five years old, is obliged to carry ten stone; if six, eleven; and if seven, twelve. It was also ordained that no person shall run any horse at a course, unless it be his own, nor enter more than one horse for the same plate, upon pain of forfeiting the horses; and also every horse-race must be begun and ended in the same day. Horses may run for the value of £50 with any weight, and at any place: 13 Geo. II. cap. 19; 18 Geo. II. cap. 34. *Be-renger's History and Art of Horsemanship.* A plaintiff shall not be allowed to recover a wager on such a horse-race as is illegal within the statute. 4 Term. Rep. 1. A match for £25 a side is a match for £50.

**RACEMATION**, *n. s.* Lat. *racemus*. Cluster, like that of grapes.

A cock will in one day fertilitate the whole *racemation* or cluster of eggs, which are not excluded in many weeks after. *Browne.*

**RACHORE**, a district of Hindostan in the province of Bejapore. It is bounded on the north by the Kistnah, and on the south by the Tungbudra, and is extremely fertile. Its chief towns are Rachore and Anamsagar.

**RACINE** (John), of the French academy, treasurer of Moulins, and secretary to Louis XIV., was born at Ferre-Milon in 1639. He produced his *Thebaide* when very young; and afterwards other pieces, which met with great success, though they appeared when Corneille was in his highest reputation. In his career, however, he did not fail to meet with opposition from envy and cabal. Owing to chagrin from this circumstance, and partly, it is said, from religious motives, he resolved to quit the theatre for ever, in his thirty-eighth year; he even formed a design of becoming a Carthusian friar, but at last married the daughter of the treasurer of Amiens, by whom he had seven children. He had been admitted a member of the French academy in 1673, and in 1677 he was nominated with Boileau, with whom he was ever in strict friendship, to write the history of Louis XIV. Boileau and Racine, after having for some time labored at this work, perceived that history was not their fort, and Racine spent the latter years of his life in composing an account of the house of Port-royal, the place of his education; which, though well drawn up, has not been published. Having drawn up a memorial upon the miseries of the people, and the means of relieving them, he one day lent it to madame de Maintenon, when the king, coming in, commended the zeal of Racine, but disapproved of his meddling with things that did not concern him. The king's displeasure is said to have so mortified the poet that it brought on a fever, of which he died the 22d of April, 1699. The king sent often to him in his illness; and after his death settled a handsome pension upon his family.—There is nothing in the French language written with more wit and elegance than his pieces in prose; and, besides his plays, several of his letters have been published. Racine's works were printed at Amsterdam in 1722, in 2 vols. 12mo., and a pompous edition was printed in 2 vols. 4to., in 1723.

**RACINESS**, *n. s.* From *racy*. The quality of being racy.

His images and descriptions of the scenes or operations of nature do not seem to be always copied from original form, nor to have the freshness, *raciness*, and energy of immediate observation. *Johnson.*

RACK, *n. s., v. a. & v. n.* } Belg. *rakke*, from  
 RACK'-RENT, *n. s.* } *rekken*, to extend,  
 RACK'-RENTER. } draw out, stretch;  
 Goth. *reckia*. An engine of torture by stretching the limbs; any instrument of extension; a trail of clouds as driven by the wind: Shakspeare uses it for wreck: torment; torture: to rack is to stream or extend out as clouds before the wind; to torment by the rack; torment in any way; screw; force; extend; defecate or draw off from the lees: rack-rent is rent stretched to the utmost: rack-renter, he who pays it.

The landlords there shamefully rack their tenants, exacting of them, besides his covenants, what he pleaseth. *Spenser.*

They, *racking* and stretching Scripture further than by God was meant, are drawn into sundry inconveniences. *Hooker.*

Vex not his ghost; O let him pass! he hates him That would upon the rack of this rough world Stretch him out longer. *Shakspeare. King Lear.*

The great globe itself,  
 Yea, all which it inherits, shall dissolve;  
 And, like this insubstantial pageant, faded,  
 Leave not a rack behind. *Id. Tempest.*

We often see against some storm,  
 A silence in the heavens, the rack stand still,  
 The bold winds speechless, and the orb below  
 As hush as death. *Id. Hamlet.*

Three glorious suns, each one a perfect sun,  
 Not separated with the *racking* clouds,  
 But severed in a pale clear-shining sky. *Shakspeare.*

The winds in the upper region, which move the clouds above, which we call the rack, and are not perceived below, pass without noise. *Bacon.*

It is common to draw wine or beer from the lees, which we call *racking*, whereby it will clarify much sooner. *Id.*

Did ever any man upon the rack afflict himself, because he had received a cross answer from his mistress? *Taylor.*

These bows, being somewhat like the long bows in use amongst us, were bent only by a man's immediate strength, without the help of any bender or rack that are used to others. *Wilkins.*

A fit of the stone puts a king to the rack, and makes him as miserable as it does the meanest subject. *Temple.*

The sisters turn the wheel,  
 Emptly the woolly rack, and fill the reel. *Dryden.*

As wintery winds contending in the sky,  
 With equal force of lungs their titles try;  
 They rage, they roar: the doubtful rack of heaven  
 Stands without motion, and the tide undriven. *Id.*

Let them feel the whip, the sword, the fire,  
 And in the tortures of the rack expire. *Id.*

He took possession of his just estate,  
 Nor *racked* his tenants with increase of rent. *Id.*  
 Hold, O dreadful sir,  
 You would not rack an innocent old man. *Id. and Lee.*

Unhappy most like tortured me,  
 Their joints new set to be new *racked* again. *Cowley.*

The' apostate angel, though in pain,  
 Vanishing aloud, but *racked* with deep despair. *Milton.*

The wisest among the heathens *racked* their wits, and cast about every way, managing every little argument to the utmost advantage.

*Tillotson's Sermons.*  
 Though this be a quarter of his yearly income, and the publick tax takes away one hundred, yet this influences not the yearly rent of the land, which the *rack-renter* or undertenant pays. *Locke.*

Some roll their cask about the cellar to mix it with the lees, and, after a few days resettlement, rack it off. *Mortimer.*

It was worth the while for the adversary to *rack* invention, and to call in all the succours of learning and critical skill to assail them, if possible, and to wrest them out of our hands. *Waterland.*

Have poor families been ruined by *rack-rents*, paid for the lands of the church? *Swift's Miscellanies.*

RACK, *n. s.* Sax. *pracca pruc*; Goth. *rygg*, the back-bone; Gr. *ραχις* (see RIDGE). Hence formerly a neck of mutton cut for the table; and (probably from its similarity of shape) the grate in which hay is placed for cattle, or on which bacon is dried: others derive this last word from Belg. *rak*; Swed. *racke*, range. See RANGE.

Their bulls they send to pastures far,  
 Or bill, or feed them at full racks within. *Mary's Virgil.*

The best way to feed cattle with it is to put it in racks, because of the great quantity they tread down. *Mortimer.*

He bid the nimble hours  
 Bring forth the steeds; the nimble hours obey:  
 From their full racks the generous steeds retire. *Addison.*

The RACK is an instrument of torture, furnished with pulleys, cords, &c., for extorting confession from criminals. The trial by rack is utterly unknown to the law of England; though once, when the dukes of Exeter and Suffolk, and other ministers of Henry VI. had laid a design to introduce the civil law into this kingdom as the rule of government; for a beginning they erected a rack for torture, which was called in derision the duke of Exeter's daughter, and still remains in the tower of London, where it was occasionally used as an engine of the state not of the law, more than once in the reign of queen Elizabeth. But when, upon the assassination of Villiers, duke of Buckingham, by Felton, it was proposed in the privy council to put the assassin to the rack, to discover his accomplices; the judges, being consulted, however, declared unanimously, to their own honor and that of the law, that no such proceeding was allowable by the laws of England. The marquis Beccaria (chap. 16) has proposed this problem, with a gravity and precision truly mathematical: 'The force of the muscles, and the sensibility of the nerves of an innocent person being given, it is required to find the degree of pain necessary to make him confess himself guilty of a given crime?'

RACK, a spirituous liquor made by the Tartars of Tongusia. This kind of rack is made of mare's milk, which is left to be sour, and afterwards distilled twice or thrice between two earthen pots closely stopped; whence the liquor runs through a small wooden pipe.

RACK (Edmund), a celebrated writer on agriculture, was born in Norfolk, and a Quaker. He

wrote many essays, poems, and letters, and some controversial tracts. He settled, about his fortieth year, at Bath in 1775, and was soon introduced to the most eminent literati of that place, among whom Dr. Wilson and Mrs. Macauley highly esteemed him for his integrity and abilities. In 1777 he published *Mentor's Letters*, a work which has run through many editions; and laid the plan of an agricultural society, which was soon adopted by four counties. He still further advanced his fame by his papers in the *Farmer's Magazine*, and his communications to the Bath Society's papers. His last engagement was in the History of Somersetshire, where he wrote the topographical parochial surveys. This work, in 3 vols. 4to., was published in 1791, by his colleague the Rev. Mr. Collinson. Mr. Rack died of an asthma in February 1787, aged fifty-two.

**RACKET**, *n. s.* Fr. *raquetta*; Teut. *racket*; Ital. *rachetta*. The instrument with which a ball is struck at tennis: the noise of a racket-court; hence any loud irregular noise.

That the tennis-court keeper knows better than I it is a low ebb of linen with thee, when thou keepest not racket there. *Shakespeare.*

When we have matcht our rackets to these balls, We will in France play a set, Shall strike his father's crown into the hazard. *Id.*

The body into which impression is made, either can yield backward or it cannot: if it can yield backward, then the impression made is a motion; as we see a stroke with a racket upon a ball makes it fly from it. *Digby on the Soul.*

He talks much of the motives to do and forbear, how they determine a reasonable man, as if he were no more than a tennis-ball, to be tossed to and fro by the rackets of the second causes.

*Bramhall against Hobbes.*

Ambition hath removed her lodging, and lives the next door to faction, where they keep such a racket that the whole parish is disturbed and every night an uproar. *Swift.*

**RACKOON**, *n. s.* Or racoon. A species of *URSUS*, which see.

The *racoon* is a New England animal, like a badger, having a tail like a fox, being clothed with a thick and deep fur: it sleeps in the day time in a hollow tree, and goes out at nights, when the moon shines, to feed on the sea side, where it is hunted by dogs. *Bailey.*

**RACONIGI**, or **RACONIS**, a town of Piedmont, Italy, in the province of Saluzzo, on the river Grana, near its junction with the Maira. It is surrounded with a wall, and contains several good churches, but its chief ornament is a magnificent castle and park belonging to the prince of Carignano. Population 10,500, employed for the most part in the manufacture of silk. Ten miles south of Carignano, and twenty south of Turin.

**RACONIN**, in zoology. See *URSUS*.

**RACY**, *adj.* Of *RACE*, a root, which see. Strongly flavored; tasting strongly of the root.

Rich racy verses in which we The soil, from which they come, taste, smell, and see. *Cowley.*

From his brain that Helicon distil, Whose racy liquor did his offspring fill. *Denham.*

The cyder at first is very luscious, but, if ground more early, it is more racy. *Mortimer's Husbandry.*

The hospitable sage, in sign Of social welcome, mixed the racy wine, Late from the mellowing cask restored to light, By ten long years refined, and rosy bright. *Pope.*

**RADCLIFFE** (Dr. John), an eminent English physician, born at Wakefield in Yorkshire in 1650. He was educated at Oxford, but recommended himself more by his ready wit and vivacity than by his acquisitions in learning. He began to practise at Oxford in 1675; but never paid any regard to established rules, which he censured with great acrimony; and, as this drew all the old practitioners upon him, he lived in a continual state of hostility with them. Yet his reputation increased so much that, before he had been two years in business, his practice was very extensive among persons of high rank. In 1684 he removed to London, and settled in Bow Street, Covent Garden, where in less than a year he had the first practice. In 1687 the princess Anne of Denmark made him her physician; yet, when she and her husband joined the prince of Orange, Radcliffe excused himself from attending them, on pretence of the multitude of his patients. Nevertheless he was often sent for to king William, and incurred censure for his treatment of queen Mary, who died of the small-pox; and soon after lost his place about the princess Anne by his attachment to the bottle. He also totally lost the favor of king William by his uncourtly freedom. In 1699, when the king showed him his swollen ancles, while the rest of his body was emaciated, and asked him what he thought of them? 'Why truly I would not have your majesty's two legs for your three kingdoms,' replied Radcliffe. He continued increasing in business and insolence as long as he lived, and was continually at war with his brethren the physicians; who considered him in no other light than that of an active ingenious empiric. He died in 1714; and, if he never attempted to write any thing himself, has perpetuated his memory by founding a fine library at Oxford.

**RADCLIFFE** (Ann), a modern female novelist, born in London, July 9th, 1764. Her father's name was Ward, and at the age of twenty-three she married William Radcliffe, esq., a student at law, which profession, however, he never followed, but became proprietor of the English Chronicle. Mrs. Radcliffe's first performance was a romance, entitled the Castles of Athlen and Dumblaine, and the next the Sicilian Romance; but the first of her works which attracted much attention was the Romance of the Forest, which was followed by the Mysteries of Udolpho, a very popular and well conceived tale. Her last work, the Italian, produced her, it is said, the sum of £1500. Besides these works she published a quarto volume of Travels through Holland and along the Rhine, in 1793. Mrs. Radcliffe suffered much in the latter part of her life from asthma, of which she died in London, January 9th, 1823.

**RADDOCK**, or **RUDDOCK**, *n. s.* From red. A bird; the red breast.

The raddock would With charitable bill bring thee all this. *Shakespeare.*

**RA'DIANCE**, *n. s.* } All of Lat. *radio*. Lustre; glitter of light: radiant is, shining; brilliant with rays; emitting rays: to radiate, to shine; emit rays; sparkle: radiated, adorned with rays, or emitting rays: radiation, emission of rays; emission from a centre; beamy lustre.

By the sacred radiance of the sun,  
By all the operations of the orbs,  
Here I disclaim all my paternal care.

*Shakspeare.*

There was a sun of gold radiant upon the top, and before, a small cherub of gold with wings displayed.

*Bacon.*

Sound paralleleth in many things with the light and radiation of things visible. *Id.* *Natural History.*

Should I say I lived darker than were true,  
Your radiation can all clouds subdue,  
But one; 'tis best light to contemplate you. *Donne.*

The sun

Girt with omnipotence, with radiance crowned.  
Of majesty divine. *Milton.*

I see the warlike host of heaven,  
Radiant in glittering arms and beamy pride,  
Go forth to succour truth below. *Id.*

Whether there be not too high an apprehension above its natural radiancy, is not without just doubt; however it be granted a very splendid gem, and whose sparkles may somewhat resemble the glances of fire.

*Browne's Vulgar Errors.*

Though with wit and parts their possessors could never engage God to send forth his light and his truth; yet now that revelation hath disclosed them, and that he hath been pleased to make them radiate in his word, men may recollect those scattered divine beams, and, kindling with them the topics proper to warm our affections, enflame holy zeal. *Boyle.*

Light radiates from luminous bodies directly to our eyes, and thus we see the sun or a flame; or it is reflected from other bodies, and thus we see a man or a picture. *Locke.*

A glory surpassing the sun in its greatest radiancy.

*Burnet.*

The radiated head of the phoenix gives us the meaning of a passage in Ausonius. *Addison.*

**RADICAL**, *adj.* } Fr. *radical*; Lat. *radix*.  
**RADICAL'ITY**, *n. s.* } Original; primitive; im-  
**RAD'ICALLY**, *adv.* } planted by nature; it has  
**RAD'ICATE**, *v. a.* } lately been used also in  
**RADICA'TION**, *n. s.* } the sense of effectual;  
**RAD'ICLE**. } penetrating to the root:

radicality is, origination: radically follows the senses of radical: to radicate is to plant or root firmly: radication, the act of taking root: radicle, that part of the seed which becomes the root.

The differences, which are secondary, and proceed from these radical differences, are, plants are all figurate and determinate, which inanimate bodies are not. *Bacon.*

Meditation will radicate these seeds, fix the transient gleam of light and warmth, confirm resolutions of good, and give them a durable consistency in the soul. *Hammond.*

They that were to plant a church, were to deal with men of various inclinations, and of different habits of sin, and degrees of radication of those habits; and to each of these some proper application was to be made to cure their souls. *Id.*

If the radical moisture of gold were separated, it might be contrived to burn without being consumed. *Wilkie.*

If the object stays not on the sense, it makes not impression enough to be remembered; but, if it be repeated there, it leaves plenty enough of those images behind it to strengthen the knowledge of the object: in which radicated knowledge, if the memory consist, there would be no need of reserving those atoms in the brain. *Glanville's Defence.*

There may be equivocal seeds and hermaphroditical principles, that contain the radicality and power of different forms; thus in the seeds of wheat there lieth obscurely the seminality of darnel.

*Browne's Vulgar Errors.*

Nor have we let fall our pen upon discouragement of unbelief, from radicated beliefs, and points of high prescription. *Browne.*

These great orbs thus radically bright,  
Primitive founts, and origins of light,  
Enliven worlds denied to human sight. *Prior.*

Radicle is that part of the seed of a plant which, upon its vegetation, becomes its root. *Quincy.*

The sunbeams render the humours hot, and dry up the radical moisture. *Arbuthnot.*

Such a radical truth, that God is, springing up together with the essence of the soul, and previous to all other thoughts, is not pretended to by religion. *Bentley.*

**RADICAL**. That which is considered as constituting the distinguishing part of an acid, by its union with the acidifying principle or oxygen, which is common to all acids. Thus, sulphur is the radical of the sulphuric and sulphurous acids. It is sometimes called the base of the acid, but base is a term of more extensive application.

**RADISH**, in botany. See **RAPHANUS**.

**RADIUS**, in anatomy. See **ANATOMY**.

**RADNOR**, **NEW**, or **MAESYFED-NEWYOLD**, a borough and market-town, the chief town of Radnorshire, situated on the river Sommergill, at the narrow entrance of a pass between two high pointed hills, is twenty-four miles north-west from Hereford, and 156 W. N. W. from London. The town was formerly defended by a strong castle, which has been destroyed. Owen Glyndower, in the reign of Henry IV., nearly burnt the place to the ground; and it now only consists of one irregularly built street. It was a borough by prescription, till the reign of queen Elizabeth, when a charter was granted it, with many privileges, together with a manor containing eleven townships, and a jurisdiction extending ten or twelve miles in circuit. The church stands on an eminence above the town, and is a very small edifice. The town-hall is a mean building. The corporation consists of a bailiff, twenty-five burgesses, &c., and, jointly with Rhaiaader and Knighton, sends one member to parliament, elected by about 300 voters. The borough has a court of pleas for all actions without limitation, but the assizes are held at Presteigne. In the neighbourhood is a cataract, called Water-break-neck, which precipitously descends into a vast hollow, surrounded by craggy declivities. Market on Saturday. Fair October 18th. It is a rectory, value £13, Patron, the king.

**RADNOR**, **OLD**, or **MAESYFED-FEN**, a parish two miles south-east from New Radnor, and sometimes called Pen-y-craig, from its situation on the summit of a rock. The church is a large stone building, consisting of a nave and chancel.



**RADNORSIIIRE**, a county of the principality, derives its name from Radnor the county town, but is called by the Welsh *Sir Vaes-ivid*. It is an inland county of South Wales, bounded by Herefordshire and a part of Shropshire on the east; by Brecknockshire on the south; by the same county and part of Montgomeryshire and Shropshire on the north, and is twenty-four miles in length from east to west, twenty-two in breadth from north to south, and about ninety miles in circumference. Radnorshire is divided into six hundreds, and fifty-two parishes.

This county was in the time of the Romans part of the country of the Silures, and contains several barrows; most of the mountains have cairns or large heaps of stones, probably intended as memorials of the dead. One of the most celebrated remains of antiquity in this county is part of a work called by the Welsh *Rlawdh Offa*, or *Offa's Dyke*, from its having been cut by Offa king of Mercia, as a boundary between the English Saxons and the ancient Britons. This dyke may be traced from the mouth of the Wye to that of the Dee, through the whole extent of the county. We are told that king Harold made a law that whatever Welshman should be found armed on the east side of the dyke should have his right hand cut off. There are the ruins of several castles, particularly those of Kevn Lyks, and of Tinbod, which last stood on the summit of a hill, and was destroyed in the year 1260 by Llewelyn, prince of Wales. The only religious house in this county was at Combeire, where Cadwathelan ap Madoc in 1143 founded a Cistercian abbey, which was dedicated to St. Mary; and, at the suppression of religious houses by Henry VIII., had a revenue of £28 17s. 4d. per annum.

The principal river of this county is the Wye, which skirts it from north-west to south-east, constituting the boundary between Brecknockshire and Radnorshire. The first tributary flood of any consequence that attends on its stream is Clargwen, with Clargwy, receiving as they do the Elain into their united channels before they join the Wye. This latter river in its progress is increased by the Ithor, drawing along with it the Dulas, the Clywedoc, and Cymran, all of which rise in Radnorshire; as do Edwy and Machwy, the last contributions the Wye derives from this county. The train of rivers which attend it from the Brecknockshire side is not so productive of interesting scenery and speculations connected with the mythological antiquities of the principality. The north-eastern and central parts of the county likewise abound in forests, which were once consecrated by all the natural awe of religious institutions, and as some say, by all the fictitious terrors of craftily pretended enchantment, though time has left few if any remains of the machinery, by the mouldering fragments of which we are enabled in some other places to weigh the credulity of the disciples against the wit and ingenuity of the instructors. The eastern part of Radnorshire is upon the whole a fine and beautiful country. The Lug is on this side the principal river. It rises in the interior of the county, and quits it for Herefordshire at Prestain. Afterwards at Lemster it takes

in the Arro, the source of which is likewise in Radnorshire. But the Lug is rather to be considered as a Herefordshire river, from its longer course through the north of that county, the superior plenteousness of its streams, and the many brooks it brings with it. Radnorshire, in a picturesque point of view, is generally considered as the least interesting of the Welsh counties. If this is to be understood as applying to it on the whole, it is undoubtedly true; for both its grandeur and beauty are, with a few exceptions, confined to its western side, on a narrow edge of the Wye, opposite Brecknockshire, and to that north-western nook which touches upon the counties of Montgomery and Cardigan, and participates in the irrefragable majesty of their character. But Radnorshire, independently of the Wye, has insulated scenes which vie with any thing to be found in the whole compass of the district that surrounds it. We need only mention the dingle through which the Machwy runs, the vale of Edwy, and the beauties of Cwm Elain, or the vale of Does, to illustrate the truth of these assertions. In the two last especially are realised those apparent contrarieties of luxuriance and barrenness, sylvan decoration and leafless horror, the blended description of which, in works of fancy, we are apt to criticise as out of nature. They certainly are so for the most part; and our poets, to say nothing of our painters, cannot easily be acquitted of dealing in them too profusely and indiscriminately. But they do exist as exceptions to a general rule, and here seem almost to introduce the traveller into fairy land; particularly if his spirits have become languid, and the elasticity of his expectations has been slackened by toiling over the eastern division of the county, where his imagination is neither kept alive by what is grand, nor his speculation as a philosopher or economist excited by the improvements of science, working on the capabilities of nature.

The proportion of mountain to vale is probably less here than in any county of Wales, except Pembrokeshire; and the quantity of land in cultivation, compared with that which is unbroken, is certainly greater than in most, on a fair estimate of their respective dimensions. The mountains of Radnorshire are for the most part low and broad crowned, so that they might be convertible to purposes of husbandry, if there was not already a larger proportion of ground in tillage than the confined knowledge and deficient activity of the natives can turn to a lucrative account. The appearance of the farms, therefore is in too many places impoverished and hungry; but this is injuriously attributed to nature; for the most intelligent and experienced inhabitants aver the quality of the soil to be generally good, though its tendency to fertility is kept down by slovenly management, local prejudice, and indolent habits. The inhabitants can live as their fathers have lived before them, and they have no desire to live better. The consequence of an agricultural system so imperfect is, that they depend principally on their sheep, for the wool of which they find a ready market at Lemster; and this, rather than any intrinsic difference, is the reason why the price of good land in the heart

of Radnorshire bears so very disproportionate a relation to the current price in the adjoining counties of Herefordshire and Shropshire. Cattle and sheep are such staple articles that the rate at which farms let is very much governed by their possessing or not possessing right of mountain: and, as the best land for tillage in general is not that which lies contiguous to these black and barren mountains, this circumstance occasions the apparent absurdity, that some of the best land in the county is let at a lower rent than some of the worst. Such discouragement to the occupation of the more even and fertile districts, arising from the difficulty of consulting the general interests of agriculture, without sacrificing local objects, to which long cherished opinions, confirmed by the experience of partial benefit, have attached importance, must continue to depress the improvement and consequent value of land below the average standard of the times, and of the country at large. But more extensive and unprejudiced views, a broader calculation of advantages and disadvantages, a less servile adherence to established maxims, and a less timid investigation of their merits, are making way, though slowly, in these regions.

The language of Radnorshire is almost universally English. In learning to converse with their Saxon neighbours, they have forgotten the use of their vernacular tongue. It is uncommon to meet with a peasant who understands Welsh, though it seems to have been generally spoken, even in the eastern parts of this county, so lately as the middle of the seventeenth century. The angle of the county beyond Rhayader, to the north-west, is however to be excepted, where the few scattered people speak nothing else. But the features and the character of this corner participate entirely in those of Cardiganshire; and, when we recollect how near Offa's Dyke approaches to this spot, we should perhaps rather wonder that the Welsh language has lost so little ground, and not been obliged to recede still farther. Nay, in the south-east part of the county, about Clyrow, Paine's Castle, and other places in that neighbourhood, even beyond Offa's Dyke, the Welsh language is still understood, and all are able to speak it, though they decidedly affect the English. About Presteign no native understands Welsh, but it is partially known to all or most in the places five or six miles to the westward. It may indeed be suspected that the people in the east of Radnorshire are not Welshmen, who by vicinity and intermarriages have gradually changed their speech for one more fashionable, but that they are the direct descendants of the English Marches, who, with their rapacious followers, occupied the limits between England and Wales, and were pouring in upon the natives of the Welsh shires from Hereford, Shropshire, and the English part, on every slight pretence of licentiousness, disaffection, or danger. By these means they might have driven the aboriginal Britons still further into the mountainous districts, and have established themselves in their seats. Radnorshire sends two members to the imperial parliament, viz. one for the shire, and one for the town of Radnor, which gives the title of earl to the family of Pleydell-Bouverie, and the village

Vol. XVIII

of Llandrindod the title of earl of March (derived from the Marches in South Wales) to that of Lennox.

RAE, an ancient and immense city of Persia, was formerly the capital of that country. Its ruins cover a vast extent of ground. They do not, however, present any remarkable objects; for having, like other Persian cities, been composed merely of bricks dried in the sun, it has crumbled into dust, and presents now only the appearance of mounds or hillocks of sand, covered with lacquered tile. In the centre stands a village, called Sheikh Abdul Azzeem, from a son of the seventh Imam, to whose memory a noble mosque and mausoleum have been erected. Rae was destroyed by the Tartars under Zinges Khan.

RAFF, *v. a.* } Sax. *neapian*; Isl.  
RAFFLE, *v. n. & n. s.* } *rifu*; Swed. *rifeva*;  
barb. Lat. *reffare*; Fr. *raffle*. To rob; sweep;  
huddle up, or huddle away. Spenser uses the  
participle passive *raff* for torn; rent: to raffle is  
to cast dice for a prize: as a noun substantive, a  
species of lottery of this description.

Their causes and effects I thus *raff* up together.

Carew.

Letters from Hamstead give me an account there is a late institution there, under the name of *raffing* shop.

Tatler.

The toy brought to Rome in the third triumph of Pompey, being a pair of tables for gaming, made of two precious stones, three foot broad, and four foot long, would have made a fine *raffle*.

Arbutnot on Coins.

RAFFAELLE. See RAPHAEL.

RAFFLES (Sir Thomas Stamford), LL. D., was the son of Benjamin Raffles, a captain in the West India trade, and born at sea in the ship Anne, off Port Morant in Jamaica, July 6th, 1781. His father placed him for education with Dr. Anderson, of Hammersmith, whence he removed to a clerkship in the India house. In 1805 the interest of Mr. secretary Ramsay procured him the situation of assistant secretary to the government of Pulo Penang, in the straits of Malacca, whither he accompanied governor Dundas. He here applied himself to the study of the Malay language; was soon after appointed Malay translator to the government; and, in 1807, became secretary to the council and registrar of the recorder's court; the following year he was compelled, by indisposition, to retire to Malacca. In 1810 his reputation procured him the appointment of agent of the governor-general with the Malay states; and the following year, on the reduction of Batavia and Java, he was nominated lieutenant-governor of the latter. Here he continued till 1816, having, in the interval, brought the hostilities commenced against the native chiefs to a successful termination. In 1816 he returned to England, bringing with him a Javaneze prince and a most extensive collection of specimens of the productions, &c., of the Eastern archipelago. The year following appeared his History of Java, in two thick quartos, with plates. He again sailed from Falmouth in the winter of 1817, having been nominated to the residency of Bencoolen in Sumatra, with the honor of knighthood and the lieutenant-governorship of Fort

2 A

Marlborough. On reaching his government, in March 1818, he set himself forthwith to remedy many abuses, and did much towards carrying into effect the abolition of slavery. He also distinguished himself by his arrangements with the Dutch commissioners in the interest of the sultan of Palembang, and by the occupation of the island of Singapore. On his last visit to the island, in 1823, he laid the foundation of the Anglo-Chinese college, but in the following year the impaired state of his constitution induced him to return to Europe. With this view he embarked on board the *Fame*, on the 2d of February 1824; but a fire breaking out in the ship, on the evening of the same day, the vessel and property of his own to the amount of nearly £30,000 with many valuable papers, were destroyed at sea; the crew and passengers saving their lives with difficulty, and landing in a state of utter destitution, about fifteen miles from Bencoolen. Of this calamity an account remains, in a letter written by Sir Thomas to a friend in England, dated the day after the accident. In April his family embarked again on board the *Mariner*, which landed them in London, in August. Sir Thomas, however, survived his return not quite two years, dying of an apoplectic attack in July 1826. In addition to the work alluded to, he left behind him a memoir of Singapore, in MS.; besides editing Finlayson's *Mission to Siam*, 8vo., and Dr. Leyden's *Malay Annals*.

**RAFFLESIA**, a gigantic flower, discovered not many years since in the island of Sumatra; it is there very rare, is parasitical, growing on the *Cissar Augustifolius*. It seems to consist of little else than flower and root. It is diœcious, and the female flowers are unknown. The calyx or corolla consists of a ventricose tube, crowned with a ring, and divided at the summit into five equal lobes. The stamens are very numerous. The stem, which hardly rises above the root, is fleshy and covered with very large obtuse imbricated bracts. The diameter of the flower is three feet, and some parts of the calyx or corolla are three quarters of an inch in thickness. No other flower in the vegetable kingdom approaches near to these dimensions. There is a second species of the same genus, with a much smaller flower.

**RAFT**, *n. s.* Dan. *rafte*; Swed. *raff*; Lat. *ratis*. A float of timber.

Where is that son

That floated with thee on the fatal raft? *Shakespeare*.

**RAFTS** are formed by various planks of timber, fastened together side by side, so as to be conveyed more commodiously to any short distance in a harbour or road than if they were separate. The timber and planks with which merchantships are laden, in the different parts of the Baltic sea, are attached together in this manner, in order to float them down the rivers and to the shipping.

**RAFTER**, *n. s.* } Sax. *rafter*; Belg. *raf*

**RAFTERED**, *adj.* } *ter*; Goth. *raftra*, or roof tree. The cross or secondary timber of a house: furnished with rafters.

From the east, a Belgian wind  
His hostile breath through the dry rafters sent;  
The flames impelled. *Dryden*.

No raftered roofs with dance and tabor sound,  
No noontide bell invites the country round. *Pope*.

The roof began to mount aloft,  
Aloft rose every beam and rafter,  
The heavy wall climbed slowly after.

*Swift's Miscellanies*.

**RAFTERS**, in building, are pieces of timber which, standing by pairs on the reason or railing piece, meet in an angle at the top, and form the roof of a building. See **ARCHITECTURE**.

**RAG**, *n. s.* } Sax. *pnac*, *pnacode*,  
**RAG'GED**, *adj.* } torn; Swed. *raca*; Gr.

**RAG'GEDNESS**, *n. s.* } *paçoc*. A piece of cloth torn from the rest; any thing torn or tattered; mean dress: the adjective and other noun substantive corresponding: ragged is also used for uneven; broken; rugged.

Worn like a cloth,

Gnawn into rags by the devouring moth. *Sandys*.

Fathers that wear rags,  
Do make their children blind;  
But fathers that bear bags,  
Shall see their children kind.

*Shakespeare. King Lear*.

That some whirlwind bear

Unto a ragged, fearful, hanging rock,  
And throw it thence into the raging sea.

*Shakespeare*.

Poor naked wretches, wheresoe'er you are,  
That bide the pelting of this pitiless storm!  
How shall your houseless heads and unfed sides,  
Your looped and windowed raggedness defend you?

*Id.*

They took from me

Both coats and cloaks, and all things that might be  
Grace in my habit; and, in place, put on  
These tattered rags. *Chapman*.

The earl of Warwick's ragged staff is yet to be  
seen pourtrayed in their church steeple. *Curew.*

Cowls, hoods, and habits, with their wearers tost,  
And fluttered into rags. *Milton*.

He had first matter seen undrest;

He took her naked all alone,

Before one rag of form was on. *Hudibras*

Content with poverty, my soul I arm;  
And virtue, though in rags, will keep me warm.

*Dryden*.

What shepherd owns those ragged sheep? *Id.*

Rugged; not smooth.

The wolf would barter away a ragged coat and a  
raw-boned carcass, for a smooth fat one.

*L'Estrange*.

Rags are a great improvement of chalky lands.

*Mortimer*.

The moon appears, when looked upon with a good  
glass, rude and ragged.

*Burnet*.

Dressed in tatters.

As I go in this ragged tattered coat, I am hunted  
away from the old woman's door by every barking  
cur. *Arbutnot*.

**RAGAMUFFIN**, *n. s.* From rag and 'I know not what else,' says Dr. Johnson. Query *muffin*, which pervades all the northern languages; from Goth. *hufa*, to conceal. A petty mean fellow.

I have led my ragamuffins where they were prepared; there's not three of my hundred and fifty left alive; and they are for the town's end to beg during life. *Shakespeare. Henry 11.*

Shall we brook that paltry ass

And feeble scoundrel, Hudibras,

With that more paltry ragamuffin,

Ralpho, vapouring and huffing? *Hudib 11*

Attended with a crew of *ragamuffins*, she broke into his house, turned all things topsy-turvy, and then set it on fire. *Swift.*

RAGE, *n. s. & v. n.* } Fr. *rage*, of Lat. *rabies*;  
RAGEFUL, *adj.* } Anger; fury, vehemence;  
eagerness: to rage is to be heated with anger;  
be in furious passion; ravage: the adjective  
corresponding.

Why do the heathen *rage*? *Psalms* ii. 1.  
Wine is a mocker, strong drink is *raging*; and  
whosoever is deceived thereby is not wise.

This courtesy was worse than a bastinado to Zel-  
mane; so that again with *rageful* eyes she bad him  
defend himself; for no less than his life would an-  
swer it. *Sidney.*

Desire not  
T' allay my *rages* and revenges with.  
Your cold reasons. *Shakespeare.*

A popular orator may represent vices in so formid-  
able appearances, and set out each virtue in so ami-  
able a form, that the covetous person shall scatter:  
most liberally his beloved idol, wealth, and the *rage*.  
*Hammond.*

Who brought green poesy to her perfect age,  
And made that art which was a *rage*. *Cowley.*

Torment, and loud lament, and furious *rage*.  
*Milton.*

The madding wheels of brazen chariots *raged*.  
*Id.*

Heart-rending news,  
That death should license have to *rage* among  
The fair, the wise, the virtuous. *Waller.*

After these waters had *raged* on the earth, they  
began to lessen and shrink, and, the great fluctua-  
tions of this deep being quieted by degrees, the  
waters retired. *Burnet.*

You purchase pain with all that joy can give,  
And die of nothing but a *rage* to live. *Pope.*

Then may his soul its free-born *rage* enjoy  
Give deed to will, and ev'ry pow'r employ.  
*Harte.*

The rose soon reddened into *rage*,  
And, swelling with disdain,  
Appealed to many a poet's page,  
To prove her right to reign. *Cowper.*

RAGGSTONE, in mineralogy, is a genus of  
stones belonging to the class of siliceous earths.  
It is of a gray color; the texture obscurely lam-  
inar, or rather fibrous; but the laminae or  
fibres consist of a congeries of grains of a quartz  
appearance, coarse and rough. The specific  
gravity is 2.729; it effervesces with acids, and  
strikes fire with steel. Kirwan found it to con-  
tain a portion of mild calcareous earth, and a  
small proportion of iron. It is used as a whet-  
stone for coarse cutting tools. It is found about  
Newcastle, and many other parts of England.

RAGMAN'S ROLL, Rectius Ragimund's roll,  
so called from one Ragimund a legate in Scot-  
land, who, calling before him all the beneficed  
clergyman in that kingdom, caused them on oath  
to give in the true value of their benefices; ac-  
cording to which they were afterwards taxed by  
the court of Rome; and this roll, among other  
records, being taken from the Scots by Edward  
I., was redelivered to them in the beginning of  
the reign of Edward III.

RAGOUT, *n. s.* Fr. *ragout*. Meat stewed  
and highly seasoned.

When art and nature join, th' effect will be  
Some nice *ragout*, or charming fricasy. *King.*

To the stage permit  
*Ragouts* for Tereus or Thyestes drest,  
'Tis task enough for thee t' expose a Roman feast.  
*Dryden*

No fish they reckon comparable to a *ragout* of  
snails. *Addison.*

RAGULED, or RAGGED, in heraldry, jagged  
or knotted. This term is applied to a cross  
formed of the trunks of two trees without their  
branches, of which they show only the stumps.  
Raguled differs from indented, in that the latter  
is regular, the former not.

RAGUSA, a town and district or Austrian  
Dalmatia, containing the territory of the republic,  
with the islands of Curzola, Lagosta, or  
Agosta, Mileda, Guipana, Mezzo, Calamata, &c.  
It is bounded by the Turkish frontier east, and  
by the Adriatic on the west. Its area is about  
700 square miles; population about 60,000. It  
contains no town of consequence, except the  
capital. Tracts along the banks of the Narenta  
are marshy and unhealthy; but in general the  
climate is good, and the soil fertile. The rivers  
are the Narenta, Drino, Ghiuta, and Ombla.

RAGUSA, the chief town of the above district,  
and an archbishop's see, is situated on a peninsula  
on the Adriatic. The peninsula on which it stands  
forms two commodious harbours, sheltered by a  
hill from the north winds, which are so pernicious  
in the Adriatic; and the attacks of an enemy  
by land are rendered difficult by almost inacces-  
sible rocks. The town itself is surrounded by  
a wall flanked with old towers; but the harbours  
are protected by strong modern works. The  
streets are narrow, with the exception of the  
principal one which extends from north to south.  
The mansion of the chief magistrate, the cathed-  
ral, and some of the churches, are worth notice.  
The inhabitants exhibit a heterogeneous  
mixture of northern and oriental dress and lan-  
guage, and their religious and other ceremonies  
are a combination of Catholic, Greek, and even  
Pagan rites. They weave silk and woollen  
stuffs, and build some shipping, and still carry  
on a traffic with the Levant and Italy.

This city was founded in the seventh century  
by fugitives from Epidaurus. Subject for some  
time to the Roman, afterwards to the Greek em-  
pire, it became independent; and, pursuing a  
pacific policy, paid a slight tribute to Venice  
and other maritime powers. It suffered severely  
from the great earthquake of 1767; but its com-  
merce continued nearly as before, though it has  
been long eclipsed by that of the larger states of  
the south of Europe. The republic did not lose  
its independence until the successes of Buona-  
parte, who gave to marshal Marmont the title of  
duke of Ragusa. Of the men of note born here  
the most remarkable was Roscovich. It is 278  
miles east by north of Rome, and ninety-four  
south-east of Spalatro.

RAGUSA, a populous town in the south part  
of the island of Sicily, in the Val di Noto,  
on the small river Ragusa. This town is said to  
contain 20,000 inhabitants, and the environs are  
very beautiful and fertile.

RAJA, or RAJAH, the title of the Indian black  
princes, the remains of those who ruled there  
before the Moguls.

**RAJA**, the ray fish, in ichthyology, a genus belonging to the order of chondropterygia. There are five spiracula below towards the peak; the body compressed; and the mouth is situated under the head. The most remarkable species are:—

1. *R. aspera*, the rough ray, is found in Loch Broon in Scotland. The length from the nose to the tip of the tail is two feet nine inches. The tail is almost of the same length with the body. The nose is very short. Before each eye is a large hooked spine; and behind each another, beset with lesser. The upper part of the body is of a cinereous brown mixed with white, and spotted with black; and entirely covered with small spines. On the tail are three rows of great spines; all the rest of the tail is irregularly beset with lesser. The fins and under side of the body are equally rough with the upper. The teeth are flat and rhomboidal.

2. *R. batis*, the skate. This species is the thinnest in proportion to its bulk of any of the genus, and also the largest, some weighing nearly 200 pounds. The nose, though not long, is sharp pointed; above the eyes is a set of short spines; the upper part is of a pale brown, sometimes streaked with black: the lower part is white, marked with great numbers of minute black spots. The jaws are covered with small granulated but sharp-pointed teeth. The tail is of a moderate length; near the end are two fins; along the top of it is one row of spines, and on the edges are irregularly dispersed a few others. It is remarked that in the males of this species the fins are full of spines. Skates generate in March and April; at which time they swim near the surface of the water, several of the males pursuing one female. They adhere so fast together in coition that the fishermen frequently draw up both together, though only one has taken the bait. The females begin to cast their purses, as the fishermen call them (the bags in which the young are included), in May, and continue doing it till September. In October they are exceedingly poor and thin; but in November they begin to improve, and grow gradually fatter till May, when they are in the highest perfection. The males go sooner out of season than the females.

3. *R. clavata*, the thornback, is easily distinguished from the others by the rows of strong sharp spines disposed along the back and tail. In a large one seen by Mr. Pennant were three rows on the back, and five on the tail, all inclining towards its end. On the nose, and on the inner side of the forehead, near the eyes, were a few spines, and the others were scattered without order on the upper part of the pectoral fins. The mouth was small, and filled with teeth; the upper part of the body was of a pale ash color, marked with short streaks of black, and the skin rough, with small tubercles like shagreen. The belly white, crossed with a strong semilunar cartilage beneath the skin: in general the lower part was smooth, having only a few spines on each side. The young fish have very few spines on them; their backs are often spotted with white, and each spot is encircled with black. This species frequent our sandy shores; they

are very voracious, and feed on all sorts of flat fish; are particularly fond of herrings and sand eels; and sometimes eat crustaceous animals, such as crabs. These sometimes weigh fourteen or fifteen pounds, but with us seldom exceed that weight. They begin to generate in June, and bring forth their young in July and August, which (as well as those of the skate), before they are old enough to breed, are called maids. The thornback begins to be in season in November, and continues so later than the skate: but the young of both are good at all times of the year.

4. *R. electrica*, the torpedo, cramp fish, or electric ray, is frequently taken in Torbay; has been once caught off Pembroke, and sometimes near Waterford in Ireland. It is generally taken, like other flat fish, with the trawl; but there is an instance of its taking the bait. It commonly lies in water of about forty fathoms depth; and in company with the congenerous rays. A gentleman of La Rochelle, on dissecting certain females of this species, on the 10th September, found in the matrices several of the fœtuses quite formed, and nine eggs in no state of forwardness: superfœtation seems therefore to be a property of this fish. The food of the torpedo is fish, such as plaice, surmulletts, &c. They will live twenty-four hours out of the sea, and but very little longer, even if placed in fresh water. They inhabit sandy places, and will bury themselves superficially in it, by flinging the sand over, by a quick flapping of all the extremities. In this situation the torpedo gives his most forcible snock, which throws down the astonished passenger who inadvertently treads upon him. In our seas it grows to a great size, and weighs above eighty pounds. The tail is thick and round; the caudal fin broad and abrupt. The head and body, which are indistinct, are nearly round; attenuating to extreme thinness on the edges; below the body the ventral fins form on each side a quarter of a circle. The two dorsal fins are placed on a trunk of the tail. The eyes are small, placed near each other; behind each is a round spiracle, with six small cutaneous rags on their inner circumference. Mouth small; teeth minute, spicular; five openings to the gills, as in others of this genus; the skin every where smooth; cinereous brown above, white beneath.

5. *R. fullonica*, the fuller, derives its Latin name from the instruments fullers make use of in smoothing cloth, the back being rough and spiny. The nose is short and sharp. At the corner of each eye are a few spines. The membrane of nictitation is fringed; teeth small and sharp. On the upper part of the pectoral fins are three rows of spines pointing towards the back, crooked like those on a fuller's instrument. On the tail are three rows of strong spines; the middle row reaches up part of the back. The tail is slender, and rather longer than the body. The color of the upper part of the body is cinereous, marked usually with numerous black spots; the lower part is white. This, as well as most other species of rays, vary a little in color according to age. It grows to a size equal to the skate. It is common at Scarborough, where it is called the white hane or gullet.

6. *R. pastinaca*, the sting ray, does not grow to the bulk of the others; the body is quite smooth, of shape almost round, and is of a much greater thickness and more elevated form in the middle than any other ray, but grows thin towards the edges. The nose is very sharp-pointed, but short; the mouth small, and filled with granulated teeth. The irides are of a gold color; behind each eye the orifice is very large. The tail is very thick at the beginning; the spine is placed about a third the length of tail from the body; is about five inches long, flat on the top and bottom, very hard, sharp-pointed, and the two sides thin, and closely and sharply bearded the whole way. The tail extends four inches beyond the end of the spine, and grows very slender at the extremity. These fishes shed their spines, and renew them annually; sometimes the new spine appears before the old one drops off; and the Cornish call this species cardinal trilost, or three-tailed, when so circumstanced. The color of the upper part of the body is a dirty yellow, the middle part of an obscure blue; the lower side white, the tail and spine dusky. The weapon with which nature has armed this fish has supplied the ancients with many tremendous fables relating to it, which the reader may find in the works of Pliny, Ælian, and Oppian.

7. *R. oxyrinchus*, the sharp-nosed ray, nearly seven feet long, and five feet two inches broad. When just brought on shore it makes a remarkable snorting noise. The nose is very long, narrow, and sharp-pointed, not unlike the end of a spoutoon. The body is smooth, and very thin in proportion to the size; the upper part ash-colored, spotted with numerous white spots, and a few black ones. The tail is thick; towards the end are two small fins; on each side is a row of small spines, with another row in the middle, which runs some way up the back. The lower part of the fish is quite white. The mouth is very large, and furnished with numbers of small sharp teeth bending inwards.

8. *R. squalicornia*, the shagreen ray, increases to the size of the skate; is fond of launces or sand eels, which it takes generally as a bait. The form is narrower than that of the common kinds; the nose long and very sharp; pupil of the eye saphirine, on the nose are two short rows of spines; on the corner of the eyes another of a semicircular form; on the tail are two rows, continued a little up the back, small, slender, and very sharp; along the sides of the tail is a row of minute spines, intermixed with innumerable little spiculæ. The upper part of the body is of a cinereous brown, covered closely with shagreen-like tubercles, resembling the skin of a dog-fish; the under side of the body is white; from the nose to the beginning of the pectoral fins is a tuberculated space. The teeth slender, and sharp as needles.

9. *R. Banksiana*, found often in the West Indian Seas, Sir Joseph Banks informs us, is sometimes so large that it requires seven pairs of oxen to drag it along the ground. A species of ray, probably the *Banksiana*, was killed on the coast of America, the capture of which is thus

described by Mr. Mitchell of New York, in a letter to the president of the New York Lyceum of Natural History:—

‘On the 9th day of September 1823 returned from a cruise off Delaware Bay the fishing smack *Una*. She had sailed about three weeks before from New York for the express purpose of catching an enormous fish, which had been reported to frequent the ocean a few leagues beyond cape Henlopen. The adventurers of this bold enterprise have been successful. The creature is one of the huge individuals of the family of raia, or, perhaps, may be erected, from its novelty and peculiarity, into a new genus, between the squalus and the acipenser. Its strength was such that, after the body had been penetrated by two strong and well formed gigs of the best tempered iron, the shank of one of them was broken off, and the other singularly bent. The boat containing the fishermen was connected, after the deadly instrument had taken hold, with the wounded inhabitant of the deep, by a strong warp or line. The celerity with which the fish swam could only be compared to that of the harpooned whale, dragging the boat after it with such speed as to cause a wave to rise on each side of the furrow in which he moved several feet higher than the boat itself. The weight of the fish after death was such that three pair of oxen, one horse, and twenty-two men, all pulling together, with the surge of the Atlantic wave to help, could not convey it far to the dry beach. It was estimated from this (a probable estimate) to equal four tons and a half, or perhaps five tons. The size was enormous; for the distance from the extremity of one wing or pectoral fin to the other, expanded like the wing of an eagle, measures eighteen feet; over the extremity of the back and on the right line of the belly sixteen feet; the distance from the snout to the end of the tail fourteen feet; length of the tail four feet; width of the mouth two feet nine inches. The operation of combat and killing lasted nine hours. The achievement was witnessed by crowds of citizens on the shores of New Jersey and Delaware, and by the persons on board the flotilla of vessels in the bay and offing. During the scuffle, the wings, side-flaps, or vast alated fins of the monster lashed the sea with such vehemence that the spray rained around to the distance of fifty feet.’

The following interesting account of the capture of the colossal skate or ray is by lieutenant Lamont of the ninety-first regiment:—

‘The first appearance of an animal of this species,’ says the lieutenant, ‘since I have been here (about eighteen months) was about two months ago, when I was called out to the beach by some of the inhabitants, whom I found, on going there, to be assembled in great numbers to see what they called the sea devil. I confess my curiosity was not less excited than theirs when I saw floating close to the surface of the water, about twenty yards from me, a large mass of living substance, of a dark color, but of the shape and size of which I could not, at the time, form any proper idea, it being so very different from any thing I had ever before seen or heard

of, farther than that I supposed it to have been many times the size of what I now believe it was. No time was lost in setting out in pursuit of him, with harpoons, &c.; and it was not long before he was come up with, and struck with one of the harpoons; when he made off with great velocity, towing the boat after him. As he seemed to incline chiefly to the surface of the water, six or seven more harpoons were, with the assistance of several canoes that had come up, successively plunged into him, and all the boats made fast to each other, which he was obliged to pull after him, with several people in each. Such, however, was the great strength of this animal, that, after being fast in the manner I have described for upwards of four hours, and taking the boats out to sea attached to him, to a distance of about ten miles from the harbour, and having been pierced with so many wounds, he was still able to defy every effort to bring him in. It had now got late, and was dark, and an attempt was made to force him up near enough to get another large harpoon into him: this was no sooner done than he darted off; and, by an almost unaccountable and seemingly convulsive effort, in a moment broke loose from all his fetters, carrying away with him eight or ten harpoons and pikes, and leaving every one staring at his neighbour in speechless astonishment, confounded at the power of an animal which could thus snatch himself from them at a time when they conceived him completely in their power.

‘Since then some of these animals have occasionally been heard of at a distance from the harbour; and a few days ago, in coming over from fort Augusta with another gentleman, we fell in with one of them, which allowed us to get so near him that it was determined to set out the next morning to look for him. We did so; and took with us several large harpoons, muskets, pikes, &c., determined, if it were possible, to bring him in. He was descried, about eight o’clock, towards the top of the harbour, as usual floating near the surface, and moving slowly about. Having allowed the boat to get very close to him, he was struck with a harpoon, which was thrown at him in a most dexterous manner by lieutenant St. John, of the royal artillery. He immediately set out towards the mouth of the harbour, towing the boat after him with such velocity that it could not be overtaken by any of the others; after going in this way for nearly an hour he turned back, which enabled the other boats to lay hold; and four of them were tied, one after the other, to the one in which he was harpooned, with four or five people in each of them. By this means we hoped to tire him out the sooner. In about an hour and a half after he was first struck, a favorable opportunity offering, a large five-pointed harpoon, made fast to a very heavy staff, was thrown at him with such an elevation that it should fall upon him with the whole weight of the weapon. This, having been as well directed as the first, was lodged nearly in the middle of his back. The struggle he made at this time to get away was truly tremendous,—plunging in the midst of the boats,—darting from the bottom to the surface alternately—dashing the water and foam on every side

of him,—and rolling round and round to extricate himself from the pole. This might be considered as having given him the coup de grace, although, at short intervals afterwards, he was struck with two more harpoons, and several musket-balls were fired into him. Still he was able to set out again, taking the four boats after him, which he carried along with the greatest ease. Having gone in this way for some time, he came to a stop, and laid himself to the bottom, when, with all the lines that were attached to him, it was quite impossible to move him. All expedients were nearly beginning to fail, when it was proposed to slacken the lines, which being done, had the desired effect, and he again set out. Having thus got him from the ground, inch by inch was gained upon him, till he was got near the surface, when he was struck with two large pikes. He now got rather faint; and, the boats closing on him on every side, the combat became general with pikes, muskets, and every weapon we had. In fact, to such a pitch were all excited on the occasion, that, had a cool spectator seen the affray, he would undoubtedly have imagined that it was his sable majesty himself that we had got amongst us. He was now towed ashore, being about five hours since he was first struck. This required all the boats to do, and then but very slowly. His appearance now showed the extraordinary tenacity of life of which this animal must be possessed, as his whole body was literally a heap of wounds, many of which were through and through, and he was not yet quite dead. This circumstance, with his great strength, is the cause of the name which has been given him by the fishermen here, as they have never been able to succeed in taking one of them, and were firmly of opinion that it was impossible to do so.

‘This monster is of the flat fish kind. On measurement it was found to be in length and breadth nearly the same, about fifteen feet, and in depth from three to four feet. It had the appearance of having no head, as there was no prominence at its mouth; on the contrary, its exterior margin formed, as it were, the segment of a circle, with its arc towards the animal’s body, and opening into a large cavity of about two feet and a half in width, without teeth, into which a man went with so much ease, that I do not exaggerate when I say that another might have done so at the same time. On each side of the mouth projected a mass of cartilaginous substance like horns, about a foot and a half long and capable of meeting before the mouth. These feelers moved about a great deal in swimming, and are probably of use in feeding. On looking on this animal as it lay on the ground with its back upwards, it might be said to be nearly of equal dimensions on every side, with the exception of the two lateral extremities, extending to a point about four feet from the body, and a tail about five feet long, four inches and a half in diameter at the root, and tapering to the point. Above the root of the tail was the dorsal fin, and on each side of it a flat and flabby substance lying close to the body, of the appearance of fins. There were no other distinct fins, and its sole propelling power seemed to be its two late-

ral extremities, which became very flat and thin towards the point. As it shows these much in swimming, it gives the spectator an extraordinary idea of its size, as, when imperfectly seen, the conclusion naturally is, if the breadth is so great, how much greater must the length be. This animal was a female, and viviparous. On opening it a young one, about twenty pounds weight, was taken out, perfectly formed, and which has been preserved. Wishing to know what it fed upon, I saw the stomach opened, which was round, about eight inches in diameter, and quite empty. It was closely studded over with circular spots of a muscular substance. Under the stomach was a long bag, with transverse muscular layers from end to end, and which contained nothing but some slime and gravel. This muscular appearance of the digestive organs would lead one to suppose that it fed upon other fish, as is the general opinion here, though its having no teeth does not support that idea. Its weight was so great that it was impossible to ascertain it at the time; but some idea may be formed of it, when I assure you that it was with difficulty that forty men, with two lines attached to it, could drag it along the ground. Its bones were soft, and, with the exception of the jaw bones, could be cut with a knife. One ridge of bone ran from the mouth to the middle of the back, where it was met by another running transversely, from the extremities of which there were two larger ones converging towards the tail.

**RAJABARY**, a considerable trading town of Bengal, district of Dacca, on the western bank of the majestic river Megna. Long.  $96^{\circ} 21' E.$ , lat.  $23^{\circ} 25' N.$  There are innumerable towns in Hindostan to which Rajah (a prince) is the præ-nomen.

**RAJAMUNDROOG**, a town and fortress of Hindostan, province of Bejapore, commands the entrance into the navigable river Mirjee. It was taken by the British troops under general Matthews in 1783, but afterwards ceded to Tippoo. Long.  $73^{\circ} 30' E.$ , lat.  $14^{\circ} 30' N.$

**RAJAMUNDRY**, an extensive district of Hindostan, province of the Circars, bounded on the north by Cicacole, on the south by Ellore, on the west by the territories of the Nizam, and on the east by the bay of Bengal. It is fertilised by the Godavery, which partly forms its southern boundary. At the distance of thirty-five miles from the sea it divides itself into two great branches, within which it forms the island of Nagur, comprehending a triangular space of 500 square miles. This district is celebrated for its sugar. The mountains also abound with teak timber. It contains a number of towns, the chief of which is Rajamundry; but the principal sea-port is Coringa. This district was ceded by the Nizam Salabut Jung in 1753 to the French; but was taken from them by the British in 1765, and now constitutes one of the five collectorships of the province. The rajahs of this country are mentioned in the Mahometan histories as early as the thirteenth century.

**RAJAMUNDRY**, the capital of the above-mentioned district, and residence of the British civil establishment, is situated on the north side of the Godavery, and formerly possessed a good brick

fort, now in ruins. Long.  $81^{\circ} 54' E.$ , lat.  $16^{\circ} 59' N.$

**RAIANIA**, in botany, a genus of the hexandria order, and dicecia class of plants; *natura*. order eleventh, sarmentacea: *MALE CAL. sexpartite*: *COR. none*: *FEMALE CAL., as in the male*: *COR. none*; there are three styles; the fruit is roundish with an oblique wing, inferior. There are three species:—

1. *R. cordata*.
2. *R. hastata*,—and
3. *R. quinquefolia*.

**RAJCHOHAN**, an extensive uncultivated district of Hindostan, province of Gundwaneh, situated between  $23^{\circ}$  and  $24^{\circ} N.$  lat. It produces little but rice and vegetables, but abounds with game. The greater part belongs to the rajah of Corair, a tributary of the Mahrattas. The chief town is Sonehut.

**RAJEMAL**, or **RAJEMAHAL**, an unproductive district of Bengal, situated on the western side of the river Ganges, about  $25^{\circ} N.$  lat. It is inhabited by a race of small people, probably the aborigines, who speak a distinct language, and, although idolaters, cannot be esteemed Hindoos. They have never been conquered; but about the year 1780 Mr. Cleveland subdued them by gentle measures. He formed a battalion of them, consisting of 300 men, who have proved exceedingly useful. It was in this district that the experiment was first tried of granting lands to the native invalid officers and soldiers; and the traveller now passes with as much safety from human foes in this district as in any other part of India. It still, however, shelters a vast number of tigers, bears, and wild beasts.

**RAJEMAHAL**, the royal residence, an ancient city of Bengal, on the western bank of the Ganges. The modern town consists only of one street, at the foot of a range of hills, and composed of stone houses, generally two stories in height, and the ruins of a palace. It carries on a small trade with the inhabitants of the hills, and quarries supply the neighbourhood with flags and millstones. An inundation of the Ganges formerly swept away a considerable part of it; a conflagration destroyed another portion; and the transfer of the seat of government to Decca completed its ruin.

Nothing can exceed the romantic prospect of Rajemahal, with the mountains at the back of the town, when a person, emerging from the Cossimbazar River and the flat country of Bengal, enters the Ganges at Sooty, and sails up that river. There is a tradition that this place was in very ancient times the seat of a Hindoo government, and was then called Raje Girhi, or Ghur. It was first noticed by the Mahometan historians, in the year 1576, under the name of Agmahel (the house of fire), probably in allusion to an early conflagration. In 1592 rajah Man Sing, governor of Bahar and Bengal, on the part of the emperor Akbar, fixed upon this place as the capital of the two provinces, and named it in compliment to his sovereign, Akbar-nagur Rajemahal. He in consequence erected a palace and a stone wall here, having bastions at the angles and gates; and, having drawn hither all the public offices, the city soon rose in



splendor. In 1608 the Mogul governor, Islam Khan, was induced, in consequence of the invasion of the south-east of Bengal by the Portuguese, to transfer the seat of authority to Dacca. But in 1639 Shujaa, the son of Shah Jehan, again restored Rajemahal to its former dignity, and built an elegant palace here, some of the rooms of which are standing. He also strengthened the fortifications, and spent large sums of money in rendering the city worthy of the royal residence: in the following year, however, nearly the whole was destroyed by a dreadful conflagration, in which many lives were lost, and the family of the prince with difficulty escaped. About the same time the Ganges changed its bed, and, pouring its torrents against the walls, washed away many of the edifices. In 1659 Aurungzebe took it after a short siege. After the expulsion of Shuja, the Mogul governor, Meer Joomla, fixed his residence at Dacca, since which period Rajemahal has steadily declined.

**RAIKES** (Robert), a printer and philanthropist of Gloucestershire, born in 1735. His father was proprietor of the Gloucester Journal, and the son succeeded him. Having realised a property, he employed it in relieving such objects as stood in need of his assistance; but is best known for his institution of Sunday schools, which he planned conjointly with the Rev. Mr. Stock in 1781. See EDUCATION. Mr. Raikes died at Gloucester in 1811.

**RAIL**, *n. s.* Belg. *ragle*. A kind of bird.

Of wild birds Cornwall hath quail, rail, partridge and pheasant.  
*Carew's Survey of Cornwall.*

**RAIL**, *v. n.* } Fr. *railler*; Belg. *rallen*;

**RAILER**, *n. s.* } Swed. *ralla*. To use reproach-

**RAIL'ERY**. } ful language; accuse; speak to or mention in opprobrious terms; formerly taking on now *at*: a railer is he who insultingly accuses or defames: railery, a diminutive of railing; slight satirical speech or manner.

Angels bring not railing accusation against them.

*2 Peter ii.*

What a monstrous fellow art thou! thus to rail on one that is neither known of thee, nor knows thee.

*Shakspeare.*

Till thou canst rail the seals from off my bone,  
Thou but offendest thy lungs to speak so loud. *Id.*

The plain the forests doth disdain:

The forests rail upon the plain. *Drayton.*

Let railery be without malice or heat.

*Ben Jonson.*

Thou art my blood, where Johnson has no part;  
Where did his wit on learning fix a brand,

And rail at arts he did not understand? *Dryden.*

If any is angry, and rails at it, he may securely.

*Locke.*

If I build my felicity upon my reputation, I am as happy as long as the railer will give me leave.

*South's Sermons.*

Studies employed on low objects; the very naming of them is sufficient to turn them into railery.

*Addison.*

To these we are solicited by the arguments of the subtle, and the raileries of the profane.

*Bentley's Sermons.*

Lesbia for ever on me rails,

To talk of me she never fails. *Swift.*

Let not presuming impious ruler tax  
Creative wisdom. *Thomson's Summer.*

**RAIL**, *n. s.* & *v. n.* Teut. *riegel*; Swed. *regel*. A cross beam fixed at the ends in posts; a series of rails; to enclose with rails; confine.

A man upon a high place without rails, is ready to fall. *Bacon.*

They were brought to London all railed in ropes, like a team of horses in a cart, and were executed some at London, and the rest at divers places. *Id.*

The hand is square, with four rounds at the corners; this should first have been planched over, and railed about with ballisters.

A large square table for the commissio... side being sufficient for those of either party, and a rail for others which went round. *Clarendon.*

If you make another square, and also a tennant, on each untenantted end of the stiles, and another mortess on the top and bottom rails, you may put them together. *Mozon.*

As the churchyard ought to be divided from other profane places, so it ought to be fenced in and railed. *Ayliff.*

Sir Roger has given a handsome pulpit-cloth, and railed in the communion table. *Addison.*

**RAIL ROADS**. These useful appendages to mining and various other works have been in use in the neighbourhood of Newcastle since the middle of the seventeenth century. They were first solely employed for transporting coals to a moderate distance from the pits, to the places where they could be shipped, being universally made of wood. 'And long,' says Dr. Anderson, 'had they been applied to this use, without any idea having been entertained that they could be employed for more general purposes.' By degrees they were, however, carried to a farther extent; and the scarcity of wood, and the expense of their repairs, suggested the idea of employing iron for the purpose of improving these roads. At the first, flat rods of bar-iron were nailed upon the original wooden rails, or, as they were technically called, sleepers; and this, though an expensive process, was found to be a great improvement. But, the wood on which these rested being liable to rot and give way, some imperfect attempts were made to make them of cast-iron, but these were found to be liable to many objections, until Mr. Outram, engineer, at Butterly Hall, Derbyshire, devoted his attention to this object. He contrived at the same time so far to diminish the expense, and improve the strength of the road, as to bring it to a degree of perfection that no one else had conceived possible. Having been carried into execution in a few cases, and found to answer, his plan has been improved upon and simplified by practice, till it is now evident that it admits of being carried much beyond even its present limits.

We cannot particularize the numerous existing rail-roads: but the chief lines that have been laid down are found in the neighbourhood of the river Wear, near Newcastle, in the coal and mining districts of Yorkshire and Lancashire, in Derbyshire, Staffordshire, and Shropshire; and in the great mining districts along the vale of the Severn. Here it was that the inclined plane was first brought in aid of inland navigation. In Surrey there is a railway of considerable extent, that presents one of the few attempts that have been made to adapt rail-roads to general use. It

has not, upon the whole, succeeded, and the original design of continuing it to Portsmouth has been for some time abandoned. In the great mining districts on the west of the Severn, including South Wales, the rail-roads are very numerous; and here, owing to the steepness and impracticable nature of the ground, they have been of essential utility in supplying the place of canals. In 1791 there was scarcely a single railway in all South Wales, and in 1811 the completed rail-roads connected with canals, collieries, iron, and copper-works in the counties of Monmouth, Glamorgan, and Caermarthen, amounted to nearly 150 miles in length, exclusive of a great extent within the mines, of which one company in Merthyr-Tydvil has thirty miles under ground. In Monmouthshire the Sirhoway railway forms one of the first in Britain in point of magnitude. It first extends thirteen miles from Pilgwell, near Newport, to the Sirhoway and Tredagar iron-works, whence it is continued five miles farther to the Trevil lime-works, in Brecknockshire, along with a branch to the west, to the Rumney and Union iron-works. This railway was made by the Monmouthshire Canal Company. A branch proceeds from Sirhoway eastwards to the Ebbwy works, and thence down the course of the Ebbwy to Crumlin Bridge, whence it joins the canal from Newport; and, from Sirhoway again, the Brinare railway is continued over the Black Mountain to the vale of the Uske at Brecon, and thence to Hay on the river Wye. In Glamorganshire the principal railways are the Cardiff and the Merthyr Tydvil, the Aberdare and the Swansea. In Caermarthenshire the principal railway is that which runs from Caermarthen to the lime-works near Llandeibie, a distance of fifteen miles. Such are the chief rail-ways in England and Wales.

In Scotland the duke of Portland's rail-road from Kilmarnock to Troin, a distance of ten miles, is the principal work of this kind yet executed; but round Glasgow, and in the coal fields of Mid Lothian and Fife, are several minor lines.

It is supposed that on a rail-way well constructed, and laid with a declivity of fifty-five feet in a mile, one horse will readily take down waggons containing from twelve to fifteen tons, and bring back the same waggons with four tons in them. This declivity, therefore, suits well, when the imports are only one-fourth part of what is to be exported. If the empty waggons only are to be brought back, the declivity may be made greater; or an additional horse applied on the returning journey will balance the increase of declivity. If the length of the rail-way were to be considered, it may, it is supposed, without much inconvenience, be varied from being level to a declivity of one inch in a yard, and by dividing the whole distance into separate stages, and providing the number of horses suitable for each portion of rail-way according to the distance and degree of declivity, the whole operation may be carried on with regularity and despatch. It is upon the whole believed that this useful contrivance may be varied so as to suit the surface of many difficult

countries, at a comparatively moderate expense. It may be constructed in a much more expeditious manner than navigable canals; it may be introduced into many districts where canals are wholly inapplicable; and in case of any change in the working of mines, pits, or manufactories, the rails may be taken up and laid down again in new situations at no very great expense or trouble.

In laying out a line of rail-way no further general rule can be laid down than that regard should in the first place be had to such a direction and such a declivity as may best suit the nature of the ground through which it passes, and the trade to be carried on upon it. If the trade be all or chiefly in one direction, the road should of course decline that way, so that the waggons, with their contents, may descend on this inclined plane as much as possible by their own weight. If the exports and imports be equal, the road should be on a level; and, where the ground will not permit that declivity or level best suited to the trade, the line should be varied, and the inequalities made up, so as to bring it as near as possible to the proper standard. If the inequalities are such as to render this impracticable, the only resource lies in inclined planes; for instance where the difference of level between the two extremities of the road is such as would render an equal declivity too steep, the road must then be carried either on a level or with the due degree of slope, as far as practicable, and then lowered by an inclined plane; on which the waggons are let gently down by means of a brake, are dragged up by means of an additional power to that which draws them along the road, or at once let down and drawn up by means of a roller or pulley.

The distance between the opposite rails of a road varies generally from three feet to four and a half feet, according as a long and narrow, or a broad short waggon is preferred. A breadth of from nine to twelve feet therefore will be sufficient for a single road, and from fifteen to twenty for a double one. The *sleepers* consist of solid blocks of stone, of the weight of one or two hundred-weight; the base must be broad, and the upper surface present an even basis for the rail. They are to be placed along each side of the road, about three feet distant from each other from centre to centre; the opposite ones being separated by the width between the opposite rails; the ground under them being rammed or beaten down to form a firm foundation; sometimes it is first laid with a coat of gravel or refuse metal. The space between them is also rammed or filled up with firm materials.

Two kinds of iron rails are in use, each of which has its warm advocates; the flat rail or tram plate, which being laid on its side, the waggon-wheels travel over the broad and flat surface, the other is termed an edge rail, the rails being laid edgewise, and the wheels travelling on their upper surfaces. The flat rail, or tram plate, consists of a plate of cast iron, about three feet long, from three to five inches broad, and from half an inch to an inch thick; extending from sleeper to sleeper, and having a flanche turn-up or crest on the inside, from two and a

half to four inches high. It bears on the sleepers at each end, where the rails are cast about half an inch thicker than in the middle, at least three inches, and as there is no intermediate bearing, except the surface of the road, the use of the flanche is to resist the transverse strain arising from the weight of the waggon; on this account it is often raised higher in the middle than at the sides, forming an arch, and, to strengthen the rail still farther, a similar flanche, arched inversely, is added below. The weight of each rail is from forty to fifty pounds. These rails are merely laid to each other, end to end, all along each side of the road; being kept in their places, and at the same time made fast to the sleepers, by an iron spike six inches long, driven through the extremity of each into a plug of oak fitted in the centre of each sleeper. This spike has no head, but the upper end of it forms an oblong square, about one inch broad, half an inch thick; and the hole in the rails, through which it passes, is formed by a notch, half an inch square, in the middle of the extremity of each rail; the opposite notches of each rail forming, when laid together, an oblong square of one inch by half an inch, and slightly dovetailed from top to bottom, so as to fit exactly the tapering head of the spike, which is driven clear below the upper surface of the rail. When the rails cross a road, the space between them and on each side must be paved up to the level of the top of the flanches, that the carriages on the road may be enabled to pass clear over the rails. In single railways it is also necessary to have a place at intervals where the empty waggons in returning may be conducted off the road and allow the loaded ones to pass. This place is termed a turn-out; and the waggons are directed into it by a moveable pointer or rail, fixed at the intersection between the principal rail and the turn-out, moving on its extremity, so as to open a way into the turn-out, and shut that along the road. This is also used whenever one line of rail-way crosses another. These flat or tram roads are universal in Wales, and the principal ones used in Scotland.

In the collieries of the north of England the flat has been almost entirely superseded by the edge rail, and the latter are admitted to be decidedly superior in case of draught, the edge of the bar presenting less friction, and being less liable to clog. The edge rail consists of a single rectangular bar of cast iron, three feet long, three or four inches broad, and from half an inch to an inch thick, set in its edge between the sleepers, and bearing on them at its ends. The upper side of the rail is flanché out to present a broad bearing surface for the wheels; the under side is also cast thicker than the middle. But the greatest strength is attained by casting the rail not rectangular, but deeper in the middle than at the ends, which may be safely reduced to nearly one-third of the depth in the middle. The rails are set in a cast iron socket or chair, attached firmly to the sleeper. This socket embraces the extremities of the adjacent rails, which are here made to overlap, and a pin is driven at once through the rails and through the socket, so as to bind the whole together. Malleable

iron has of late been used in the construction of these rails. Mr. Birkinshaw of the Bedlington Iron-works has obtained a patent for broad topped malleable rails of a wedge form. The peculiar shape is given them in the rolling of the metal, by means of grooves cut in the rollers corresponding with the requisite breadth and depth, and the curvature of the proposed rail. This seems a very great improvement.

The Westminster Review, No. VIII., assigns the merit of the invention of iron rail-ways to Mr. Curr an engineer of Sheffield. 'We yet expect,' continues the reviewer, 'to see them applied to some of the ordinary purposes of travelling. The first five miles of the Dover road are maintained at an annual expense of more than £1000 a mile, and this is chiefly caused by the sharp wheels of heavy stage-coaches. There would be no difficulty in giving rails to this class of carriages, at least, as their rapidity is equable and their times fixed. A separate rail might be applied to waggons which are equally regular in motion if not in speed; while an ordinary road might still be preserved for vehicles of irregular rates and times.'

**RAIMENT**, *n. s.* Abridged from **ARRAIMENT**. Vesture; clothes; dress; garment.

His *raiments*, though mean, received handsomeness by the grace of the wearer. *Sidney.*

O Protheus, let this habit make thee blush!

Be thou ashamed that I have took upon me

Such an immodest *raiment*.

*Shakspeare.*

Living both food and *raiment* she supplies.

*Dryden.*

You are to consider them as the servants and instruments of action, and so give them food, and rest, and *raiment*, that they may be strong and healthful to do the duties of a charitable, useful, pious life.

*Law.*

<b>RAIN</b> , <i>n. s., v. a., &amp; v. n.</i>	} Sax. <i>regon</i> , <i>nen</i> , Belg. and Teut. <i>regen</i> ; Goth.
<b>RAIN'BOW</b> , <i>n. s.</i>	
<b>RAIN-WATER</b> ,	
<b>RAINY</b> .	

*rain*. The water which falls in drops from the clouds; to fall in such drops; 'it rains,' signifying that the water falls in this way from the clouds; to pour down as rain: rainbow, the iris; the bow formed on the clouds by the sun in showery weather: rain-water, the water of the clouds; rainy, showery; wet; damp; likely to rain.

A continual dropping in a very rainy day, and a contentious woman, are alike.

*Proverbs xxvii. 15.*

Casting of the water in a most cunning manner, makes a perfect rainbow, not more pleasant to the eye than to the mind, so sensibly to see the proof of the heavenly iris.

*Sidney.*

When shall we three meet again,

In thunder, lightning, or in rain. *Shakspeare.*

That which serves for gain

And follows but for form,

Will pack when it begins to rain

And leave thee in the storm.

*Id. King Lear.*

Rain sacrificial whisperings in his ear,

Make sacred even his stirrup.

*Id. Timon of Athens.*

To add another hue unto the rainbow.

*Shakspeare.*

Court holy water in a dry house, is better than the rainwater out o' doors.

*Id. King Lear.*

Our gayness and our guilt are all besmirched,  
With *rainy* marching in the painful field.

*Shakspeare.*

The *rainbow* is drawn like a nymph with large wings spread in the form of a semicircle, the feathers of sundry colors.

*Peuchlam.*

They sat them down to weep; nor only tears  
*Rained* at their eyes, but high winds rose within.

*Milton.*

They could not be ignorant of the promise of God never to drown the world, and the *rainbow* before their eyes to put them in mind of it.

*Browne.*

The lost clouds pour  
Into the sea an useless shower,  
And the vexed sailors curse the *rain*,  
For which poor farmers prayed in vain.

*Waller.*

We took distilled *rain-water*.

*Boyle.*

Like a low hung cloud it *rains* so fast,

That all at once it falls. *Dryden's Knight's Tale.*

The wind is south-west, and the weather lowering, and like to *rain*.

*Locke.*

*Rain* is water by the heat of the sun divided into very small parts ascending in the air, till, encountering the cold, it be condensed into clouds, and descends in drops.

*Ray.*

*Rain-water* is to be preferred before spring-water.

*Mortimer.*

This *rainbow* never appears but where it rains in the sun-shine, and may be made artificially, by spouting up water, which may break aloft, and scatter into drops, and fall down like *rain*; for the sun shining upon these drops, certainly causes the bow to appear to a spectator standing in a true position to the rain and sun: this bow is made by refraction of the sun's light in drops of falling *rain*.

*Newton.*

The dome's high arch reflects the mingled blaze, And forms a *rainbow* of alternate rays.

*Pope.*

Gay *rainbow* silks her mellow charms infold,

And nought of Lyce but herself is old. *Young.*

**RAIN.** See METEOROLOGY.

**RAINBOW**, iris, is a meteor in form of a party-colored arch, or semicircle, exhibited in a rainy sky, opposite to the sun, by the refraction and reflection of his rays in the drops of falling rain. There is also a secondary, or fainter bow, usually seen investing the former at some distance. Among naturalists we also read of lunar rainbows, marine rainbows, &c.

This beautiful phenomenon has engaged the attention of all ages, and by some nations it has even been deified. The observations of the ancients and philosophers of the middle ages, concerning the rainbow, were such as could not have escaped the notice of the most illiterate husbandmen who gazed at the sky; and their various hypotheses deserve no notice. Maurolycus was the first who pretended to have measured the diameters of the two rainbows with much exactness; and he reports that he found that of the inner bow to be 45°, and that of the outer bow 56°; from which Descartes takes occasion to observe how little we can depend upon the observations of those who were not acquainted with the cause of the appearances. See OPTICS, INDEX. The moon sometimes exhibits the phenomenon of an iris or rainbow by the refraction of her rays in drops of rain. This phenomenon in the night-time is however very rare.

The marine or sea rainbow is a phenomenon which may be frequently observed in a much

agitated sea, and is occasioned by the wind sweeping part of the waves and carrying them aloft, which when they fall down are refracted by the sun's rays, painting the colors of the bow just as in a common shower. These bows are often seen when a vessel is sailing with considerable force, and dashing the waves around her, which are raised partly by the action of the ship and partly by the force of the wind, and, falling down, they form a rainbow; and they are also often occasioned by the dashing of the waves against the rocks on shore. The colors of the marine rainbow are less lively, less distinct, and of shorter continuance, than those of the common rainbow; there are scarcely more than two colors distinguishable, a dark yellow on the side next the sun, and a pale green on the opposite side; but they are much more numerous.

**RAINGUAGE.** See PLYVIOMETER.

**RAINOLDS** (John), D. D., an eminent English divine, born at Pinto in Devonshire in 1549, and sent to Merton College, Oxford, in 1562. He became fellow of Corpus Christi, where he took his degrees. In 1598 he was made dean of Lincoln, and in 1599 president of Corpus College. Queen Elizabeth offered him a bishopric, but he modestly refused it, saying in earnest, *Nolo episcopali*. He wrote and published a great number of works, and was one of the learned divines employed by James I. to translate the Bible. He was moderately inclined to puritanism. He died in 1607.

**RAINY RIVER**, a river of Illinois, which rises near the west border of Indiana, flows W. N. W., and joins the Illinois, long. 88° 5' W., lat. 41° 20' N.

**RAINY LAKE**, a lake of North America, divided by an isthmus near the middle into two parts. The west part is called the Great Rainy Lake, the east the Little Rainy Lake, being the least division. It is in general very shallow in its depth. The broadest part of it is not more than twenty miles; its length, including both, about 300 miles. In the west part the water is very clear and good, and some excellent fish are taken in it. A great many fowl resort here at the fall of the year. Moose deer are to be found in great plenty, and likewise the Carraboo, whose skin, for breeches or gloves, exceeds by far any other to be met with in North America.

**RAIRY**, a celebrated fortress of Hindostan, in Bejapore. It is situated on the top of a steep hill, and was the favorite residence of the Mah-ratta chief Sevajee.

**RAISE**, *v. a.* } Swed. *resa*; Dan. *reisa*.  
**RAISER**, *n. s.* } Teut. *reitzen*; Gr. *επειζω*?  
To lift; heave; erect; exalt; set up; advance; excite; irritate; rouse: he who raises.

*Raise* not a false report. *Exodus* xxiii. 1.

Take his carcase down from the tree, cast it at the entering of the gate, and *raise* thereon a heap of stones.

*Joshua* viii.

He *raiseth* the stormy wind. *Psalms* cvii. 28.

Then shall stand up in his estate a *raiser* of taxes.

*Daniel* xi.

They neither found me in the temple disputing with any man, neither *raising* up the people. *Acts*.

It is sown in dishonour, it is *raised* in glory; it is sown in weakness, it is *raised* in power.

1 *Corinthians* xv. 25

The spirits of the deceased, by certain spells and infernal sacrifices, were raised. *Sandys's Journey.*

That eyeless head of thine was first framed flesh,  
To raise my fortunes. *Shakspeare. King Lear.*

He first raised head against usurping Richard.

Counsellors may manage affairs, which nevertheless are far from the ability to raise and amplify an estate. *Bacon.*

They that are the first raisers of their houses are most indulgent towards their children. *Id.*

And drinke the dark-deepe water of the spring,  
Bright Arethusa, the most nourishing  
Raiser of heards. *Chapman.*

He that boasts of his ancestors, the founders and raisers of a family, doth confess that he hath less virtue. *Taylor.*

This gentleman came to be raised to great titles. *Clarendon.*

Thou so pleased,  
Canst raise thy creature to what height thou wilt  
Of union. *Milton.*

He might taint  
The' animal spirits, that from pure blood arise,  
Thence raise distemp'ered thoughts. *Id.*

God vouchsafes to raise another world  
From him. *Id.*

He out of smallest things could without end  
Have raised incessant armies. *Id.*

The common ferryman of Egypt, that wafted over the dead bodies from Memphis, was made by the Greeks to be the ferryman of hell, and solemn stories raised after him. *Browne.*

The plate pieces of eight were raised three-pence in the piece. *Temple's Miscellanies.*

*Aeneas* then employs his pains

In parts remote to raise the Tuscan swains. *Dryden.*

All gaze, and all admire, and raise a shouting sound. *Id.*

These are spectres the understanding raises to itself, to flatter its own laziness. *Locke.*

Miss Liddy can dance a jig, and raise paste. *Spectator.*

The Persians gazing on the sun,  
Admired how high 'twas placed, how bright it shone;  
But, as his power was known, their thoughts were raised,

And soon they worshipped what at first they praised. *Prior.*

I should not thus be bound,  
If I had means, and could but raise five pound. *Gay.*

Britain, once despised, can raise  
As ample sums, as Rome in *Cæsar's* days. *Arbutnot.*

Such a bulk as no twelve bards could raise,  
Twelve starveling bards in these degenerate days. *Pope.*

Gods encountering gods, Jove encouraging them  
with his thunders, and Neptune raising his tempests. *Id.*

Raiser of human kind! by nature cast,  
Naked and helpless. *Thomson's Autumn.*

Content if thus sequestered I may raise

A monitor's, though not a poet's praise,

And while I teach an art too little known,

To close life wisely, may not waste my own. *Cowper.*

RAISIN, *n. s.* Fr. *raisin*; Arab. *rasa*; Lat. *racemus*. A dried grape.

Raisins are the fruit of the vine suffered to remain on the tree till perfectly ripened, and then dried: grapes of every kind, preserved in this manner, are called raisins, but those dried in the sun are much

sweeter and pleasanter than those dried in ovens; they are called jar raisins, from their being imported in earthen jars. *Hill.*

Dried grapes or raisins, boiled in a convenient proportion of water, make a sweet liquor, which, being betimes distilled, affords an oil and spirit much like the raisins themselves. *Boyle.*

RAISINS. To obtain fine raisins tie two or three bunches of grapes together while yet on the vine, and dip them into a hot *lixivium* wood ashes, with a little of the oil of olives in it. This disposes them to shrink and wrinkle; after this they are left on the vine three or four days separated on sticks in an horizontal situation, and then dried in the sun at leisure, after being cut from the tree. The finest and best raisins are those called in some places *Damascus* and *Jube* raisins; which are distinguished from the others by their size and figure; they are flat and wrinkled on the surface, soft and juicy within, and nearly an inch long; and, when fresh and growing on the bunch, are of the size and shape of the large olive. The raisins of the sun are all dried by the heat of the sun; and these with the jar raisins are the sorts used in medicine. However all the kinds have much the same virtues; they are all nutritive and balsamic; they are allowed to be attenuant, are said to be good in nephritic complaints, and are an ingredient in pectoral decoctions: in which cases, as also in all others where astringency is not required of them, the stones should be carefully taken out.

RAKE, *n. s., v. a., & v. n.* Sax. *pace*; Belg.

RAKEHELL, *n. s.* } *racche*; Swedish

RAKE'HELLY, *adj.* } *raka* (to scrape);

RA'KISH. } Teut. *rechen*. An

instrument with teeth designed to collect or scrape things together; hence (Fr. *racaille*, the rabble) both a rake, a low worthless fellow, and rakehell, according to Skinner, of the same signification: to rake is to gather or clear with a rake; collect; and hence heap; scour; and, in nautical affairs, to fire so as to search a vessel: as a verb neuter, to search; grope; the adjectives both mean wild; dissolute.

At Midsummer down with the brembles and brakes,

And after abroad with thy forkes and thy rakes. *Tusser.*

Mow barlie, and rake it, and set it on cocks. *Id.*

When Pas hand reached him to take

The fox on knees and elbows tumbled down:

Pas could not stay, but over him did rake,

And crowned the earth with his first touching crown. *Sidney.*

Out of the frie of these rakehell horse-boys, growing up in knavery and villany, are their kern supplied. *Spenser.*

I scorn the rakehelly rout of our ragged rhimers, which without learning boast, without judgment jangle, and without reason rage and foam. *Id.*

An eager desire to rake together whatsoever might prejudice or any way hinder the credit of apocryphal books, hath caused the collector's pen so to run as it were on wheels, that the mind, which should guide it, had no leisure to think. *Hooker.*

What piles of wealth hath he accumulated!

How, i' th' name of thrift,

Does he rake this together? *Shakspeare. Henry VIII.*

If you hide the crown  
Even in your hearts, there will he *rake* for it.

*Shakespeare.*

The king, when he heard of Perkins' siege of Exeter, said in sport, that the king of *rakehells* was landed in the West, and that he hoped now to see him.

*Bacon.*

No breaking of windows or glasses for spight,  
And spoiling the goods for a *rakehelly* prank.

*Ben Jonson.*

The blazing wood may to the eye seem great,  
But 'tis the fire *raked* up that has the heat,

And keeps it long.

*Suckling.*

Harrows' iron teeth shall every where  
*Rake* helmets up.

*May's Virgil's Georgicks.*

A sport more formidable

Had *raked* together village rabble.

*Hudibras.*

O that thy bounteous deity would please

To guide my *rake* upon the chinking sound

Of some vast treasure hidden under ground.

*Dryden.*

Another finds the way to dye in grain ;

Or for the golden ore in rivers *rakes*,

Then melts the mass.

*Id. Persius.*

One is for *raking* in Chaucer for antiquated words,  
which are never to be revived, but when sound or  
significancy is wanting.

*Dryden.*

The Belgians tack upon our rear,  
And *raking* chase-guns through our sterns they send.

*Id.*

Ill-gotten goods are squandered away with as  
little conscience as they were *raked* together.

*L' Etrange.*

It is as offensive as to *rake* into a dunghill.

*South.*

He examines his face in the stream, combs his  
rueful locks with a *rake*.

*Garth.*

The next came with her son, who was the greatest  
*rake* in the place, but so much the mother's darling,  
that she left her husband for the sake of this grace-  
less youth.

*Addison.*

After having made essays into it, [as they do for  
coal in England, they *rake* into the most promising  
parts.

*Id.*

*Rakes* hate sober grave gentlewomen.

*Arbutnot.*

Men, some to business, some to pleasure take,

But every woman is at heart a *rake*.

*Pope.*

The statesman *rakes* the town to find a plot.

*Swift.*

A *rakehell* of the town, whose character is set off  
with excessive prodigality, prophaneness, intempe-  
rance, and lust, is rewarded with a lady of great  
fortune to repair his own, which his vices had almost  
ruined.

*Swift.*

As they *rake* the green appearing ground,

The russet hay-cock rises.

*Thomson.*

There seldom can be peculiarity in the love of a  
*rakish* heart.

*Clarissa.*

To dance at publick places, that fops and *rakes*  
might admire the fineness of her shape, and the  
beauty of her motions.

*Law*

**THE RAKE OF A SHIP** is all that part of her  
hull which hangs over both ends of her keel.  
That which is before is called the fore-rake, or  
*rake* forward, and that part which is at the set-  
ting on of the stern-post is called the *rake*-aft, or  
after-ward.

**TO RAKE A SHIP** is to cannonade her on the  
stern, or head, so as that the balls shall scour  
the whole length of her decks ; which is one of  
the most dangerous incidents that can happen in  
a naval action. This is frequently called *raking*  
fore and aft, and is similar to what is called by  
engineers enfilading.

**RALEIGH** (Sir Walte' 'ourth son of Wal-

ter Raleigh, esq., of Fardel, in the parish of  
Cornwood in Devonshire, was born in 1552.  
About 1568 he was sent to Ariel College Ox-  
ford, but next year he embarked for France,  
being one of the 100 volunteers, commanded  
by Henry Champernon, who, with other Eng-  
lish troops, were sent by queen Elizabeth to  
assist the queen of Navarre in defending the  
Protestants. In this service he continued five or  
six years ; after which he returned to London.  
In 1577 or 1578 he embarked for the Low  
Countries with the troops sent by the queen to  
assist the Dutch against the Spaniards. On his  
return to England, his half-brother, Sir Hum-  
phrey Gilbert, having obtained a patent to  
colonise some parts of North America, he em-  
barked in this adventure ; but meeting with a  
Spanish fleet, after a smart engagement, they re-  
turned without success in 1579. In 1580 Philip  
II. of Spain, having projected a conquest of Eng-  
land, sent troops to Ireland to assist the Des-  
monds in the Munster rebellion. Raleigh ob-  
tained a captaincy under lord Grey of Wilton,  
then deputy of Ireland, and embarked for that  
kingdom ; where he was greatly instrumental in  
putting an end to the war. He returned to  
England, and attracted the notice of queen  
Elizabeth, owing, as Naunton says, in his *Frug-  
menta Regalia*, to an accidental piece of gal-  
lantry. The queen taking a walk, being stopped  
by a muddy place in the road, our young gallant  
took off his new plush mantle and spread it on  
the ground. Her majesty trod gently over the  
foot-cloth, surprised and pleased with the ad-  
venture. He was a handsome man, and remark-  
able for his address. The queen admitted him  
to her court, and employed him first as an at-  
tendant on the French ambassador Simier, on  
his return home, and afterwards to escort the  
duke of Anjou to Ahtwerp. During this excu-  
sion he became personally known to the prince  
of Orange : from whom on his return he brought  
special acknowledgments to the queen. In  
1583 he embarked with his brother, Sir Hum-  
phrey, on a second expedition to Newfoundland,  
in a ship called the Raleigh, built at his own  
expense ; but was obliged to return on account  
of an infectious distemper on board. He then  
laid before the queen and council a proposal for  
exploring the continent of North America ; and  
in 1584 obtained a patent to possess such coun-  
tries as he should discover. Accordingly he  
fitted out two ships at his own expense, which  
sailed in April, and returned to England in Sep-  
tember, reporting that they had discovered a  
fine country called Windangocoa, to which the  
queen gave the name of Virginia. About this  
time he was elected member for Devon, and  
soon after was knighted ; and, to enable him to  
execute his plans, the queen granted him a  
patent for a licence on wine throughout the  
kingdom. In 1585 he sent a fleet of seven ships  
to Virginia, under his relation Sir Richard  
Grenville, who left a colony at Roanah of 107  
persons, under Mr. Lane ; and from this colony  
he first imported tobacco into England. He  
also obtained a grant of 12,000 acres of the for-  
feited lands in Cork, was made seneschal of  
Cornwall, and warden of the stanneries. In  
1587 he sent another colony of 150 men to Vir-

ginia, with a governor and twelve assistants. About this time he had the titles of captain of the queen's guards, and lieutenant-general of Cornwall. From this period to 1594 he was continually engaged in projecting new expeditions, sending succors to colonies abroad, defending the kingdom from the insults of the Spaniards, and transacting parliamentary business with equal ability and resolution. In 1594 he obtained from the queen a grant of the manor of Sherborne in Dorsetshire, where he built a magnificent house; but fell under the queen's displeasure on account of an intrigue with the daughter of Sir Nicholas Throgmorton, one of the maids of honor; he however married the lady. During his disgrace at court, he projected the conquest of Guiana in South America, and in 1595 sailed for that country; of which having taken possession, after defeating the Spaniards settled there, he returned to England and published an account of his expedition. In 1596 he was one of the admirals in the successful expedition against Cadiz, under the command of Howard and the earl of Essex; and in 1597 he sailed with them against the Azores. In 1600 he was sent on a joint embassy with lord Cobham to Flanders, and at his return made governor of Jersey. Queen Elizabeth died in 1603, and with her Raleigh's glory sunk. Upon the accession of James, Sir Walter lost his interest at court, was stripped of his preferments, and accused of a plot against the king. He was arraigned at Winchester, and on his trial shamefully insulted by Coke, the attorney-general, whose sophistical vociferations influenced the jury to convict him without the least proof of guilt. After a month's imprisonment, however, in daily expectation of his execution, he was reprieved, and sent to the Tower, his estates being given to Car, earl of Somerset, the king's favorite. During this confinement he wrote many of his most valuable pieces, particularly his History of the World. In March 1615, after sixteen years imprisonment, he obtained his liberty, and immediately began to prepare for another voyage to Guiana. In August 1616 the king granted him a very ample commission for that purpose; and in July 1617 he sailed from Plymouth; but the whole scheme was revealed to the Spaniards, and thus rendered abortive. He returned to England in 1618, where he was soon after seized, imprisoned, and beheaded; not for any pretended misdemeanor on the late expedition, but in consequence of his former attainder. The truth is, he was sacrificed by the pusillanimous monarch to appease the Spaniards; who, whilst Raleigh lived, thought every part of their dominions in danger. He was executed in Old Palace Yard, and buried in St. Margaret's adjoining, in his sixty-sixth year. His behaviour on the scaffold was manly, unaffected, cheerful, and easy. Being asked by the executioner which way he would lay his head, he answered, 'So the heart be right, it is no matter which way the head lies.' He was a man of unquestionable talents, extensive knowledge, undaunted resolution, and strict honor. He was the author of several works, which never have been printed

**RALEIGH**, a post town, the metropolis of North Carolina, in Wake county, ten miles from Wake court-house, twenty-seven north-west of Smithfield, the nearest point of navigation, sixty north of Fayetteville. It contains a state-house, a court-house, a jail, a governor's house, a market-house, a theatre, and state bank, two academies, one for males and one for females, two meeting-houses, and three printing offices, from each of which is issued a weekly newspaper. The situation of the town is pleasant and considerably elevated.

**RALLUS**, the rail, in ornithology a genus belonging to the order of gallæ. The beak is thickest at the base, compressed equal, acute, and somewhat sharp on the back near the point; the nostrils are oval; the feet have four toes, without any web; and the body is compressed. Latham enumerates twenty-four species, besides some varieties. They are chiefly distinguished by their color. 'These birds,' says Buffon, 'constitute a large family, and their habits are different from those of the other shore-birds, which reside on sands and gravels. The rails, on the contrary, inhabit only the slimy margins of pools and rivers, especially low grounds covered with flags and other large marsh plants. This mode of living is common to all the water rails. The land rail frequents meadows, and, from the disagreeable cry or rather rattling in the throat of this bird, is derived the generic name. In all the rails the body is slender, and shrunk at the sides; the tail extremely short; the head small; the bill like that of the gallinaceous kind, though much longer, and not so thick; a portion of the leg above the knee is bare; the three fore toes without membranes, and very long; they do not like other birds draw their feet under their belly in flying, but allow them to hang down; their wings are small and very concave, and their flight is short. They seem to be more diffused than varied; and they are dispersed over the most distant lands. Captain Cook found them at the Straits of Magellan; in different islands of the south hemisphere, at Anamoka, at Tanna, and at the isle of Norfolk. The principal species are:—

1. *R. aquaticus*, or water rail, is a bird of a long slender body, with short concave wings. It delights less in flying than running, which it does very swiftly along the edges of brooks, covered with bushes: as it runs, it every now and then flirts up its tail, and in flying hangs down its legs. Its weight is four ounces and a half. The length to the end of the tail is twelve inches; the breadth sixteen. The bill is slender, slightly incurvated, one inch and three quarters long: the upper mandible black, edged with red; the lower, orange-colored: the head, hind part of the neck, the back, and coverts of the wings and tail, are black, edged with an olive brown; the throat, breast, and upper part of the belly, are ash colored; the sides under the wings, as far as the rump, finely varied with black and white bars. The tail is very short, consists of twelve black feathers; the ends of the two middle tips with rust color; the feathers immediately beneath the tail white. The legs are placed far behind, and are of a dusky flesh-color. The toes very

ong, and divided to their very origin; though the feet are not webbed, it takes the water; will swim on it with much ease, but is often observed to run along the surface. 'Water rails,' says Buffon, 'are seen near the perennial fountains during the greatest part of the winter, yet, like the land rails, they have their regular migrations. The flesh of the water rail is not so delicate as that of the land rail, and has even a marshy taste, nearly like that of the gallinule. It continues the whole year in England.

2. *R. crex*, or corn-crake, has been supposed by some to be the same with the water-rail, and that it differs only by a change of color at a certain season of the year: this error is owing to inattention to their characters and nature, both which differ entirely. The bill of this species is short, strong, and thick; formed exactly like that of the water-hen, and makes a general distinction. It never frequents watery places; but is always found among corn, grass, broom, or furze. It quits the kingdom before winter; but the water-rail endures our sharpest seasons. They agree in their aversion to flight; and the legs, which are remarkably long for the size of the bird, hang down whilst they are on wing; they trust their safety to their swiftness on foot, and seldom are sprung a second time without great difficulty. The land rail lays from twelve to twenty eggs, of a dull white color, marked with a few yellow spots; notwithstanding this, they are very numerous in this kingdom. Their note is very singular; and like the quail it is decoyed into a net by the imitation of its cry, *crék crék crék*, by rubbing hard the blade of a knife on an indented bone. They are very numerous in Anglesea, where they appear about the 20th of April, supposed to pass over from Ireland, where they abound: at their first arrival it is common to shoot seven or eight in a morning. They are found in most of the Hebrides, and the Orkneys. On their arrival they are very lean, weighing only six ounces; but, before they leave this island, grow so fat as to weigh above eight. The feathers on the crown of the head and hind part of the neck are black, edged with bay color: the coverts of the wings of the same color, but not spotted; the tail is short, and of a deep bay; the belly white, the legs ash-colored.

3. *R. porzana*, the gallinule, is not very frequent in Great Britain, and is said to be migratory. It inhabits the sides of small streams, concealing itself among the bushes. Its length is nine inches, its breadth fifteen: its weight four ounces five drachms. The head is brown spotted with black; the neck a deep olive spotted with white: the feathers of the back are black next their shafts, then olive-colored, and edged with white; the scapulars are olive, finely marked with two small white spots on each web; the legs of a yellowish green. Their flesh is delicate, and much esteemed: those in particular which are caught in the rice fields in Piedmont are very fat, and of an exquisite flavor.

**RALLY, v. n.** Fr. *rallier*. To re-ally; bring disordered or dispersed troops together: as a verb neuter to come together with rapidity or into order.

Publick arguing serves to whet the wits of hereticks, and, by showing weak parts of their doctrines, prompts them to rally all their sophistry to fortify them with fallacy. *Decay of Piety.*

With rallied arms to try what may be yet Regained in heaven. *Milton.*

If God should show this perverse man a new heaven and a new earth, springing out of nothing, he might say, that innumerable parts of matter chanced just then to rally together, and to form themselves into this new world. *Tillotson.*

The Grecians rally, and their powers unite; With fury charge us. *Dryden's Æneis.*

Luther deters men from solitariness; but he does not mean from a sober solitude, that rallies our scattered strengths, and prepares us against any new encounters from without. *Att. bury.*

**RAL'LY, v. a.** Fr. *railler*; of Lat. *rioculus*, barb. Lat. *ridiculare*. To satirize; banter.

If, after the reading of this letter, you find yourself in a humour rather to rally and ridicule than to comfort me, I desire you would throw it into the fire. *Addison.*

Strephon had long confessed his amorous pain, Which gay Corinna rally'd with disdain. *Gay.*

**RALPH** (James), a political writer, born in America, and placed by his parents in a counting-house at Philadelphia. Fancying himself a poet, he deserted a wife and child, and accompanied Dr. Franklin to London, where he for some time lived at the expense of the latter. He attempted to get on the stage, offered to write for the booksellers, or copy for the law stationers, all without success. He then retired to a reclusive village in Berkshire, where he commenced school-master, borrowing his friend Franklin's name. Having finished his poem on Night, he returned to town; and, as it met with some little success, he began to be employed by the booksellers; but, having procured himself a niche in the Dunciad, they soon cast him off. He next began play-writing, and his plays, the Fashionable Lady, &c., kept him from absolute want. About 1735 he became, by some means, joint manager with Henry Fielding in the Haymarket theatre; but his emoluments do not seem to have raised him above poverty. His first political publication appeared in 1742, entitled *The other side of the question*, in answer to the duchess of Marlborough's Memoirs; and he was employed to write many others: about the end of Walpole's administration he was bought by a pension of £200 per annum, which at the death of George II. was increased by lord Bute to £600. Of the latter sum he did not enjoy above half a year's income, being cut off by the gout in 1761. He was the author of numerous works. Those most esteemed are his *Continuation of Guthrie's History of England*, and the *Review of the Reigns of Charles II. and James II.*

**RAM, n. s. & v. a.** } Saxon ram; Danish  
**RAMMER, n. s.** } ramme; Belg. ram; from Goth. *ramun*, robust. Thomson.—A male sheep; a tub; hence the sign Aries, and the ancient instrument made with a head like a ram for battering: as a verb active, to batter with such an instrument; drive violently; fill or choke by ramming: a rammer is any instrument used in ramming.



Judas calling upon the Lord, who without any *rams* or engines of war did cast down Jericho, gave a *force* assault against the walls. 2 *Mac.* xii. 15.

As when that devilish iron engine wrought  
In deepest hell, and framed by turies skill,  
With windy nitre and quick sulphur fraught,  
And *rammed* with bullet round ordained to kill.

*Spenser.*

The ewes, being rank, turned to the *rams*.

*Shakspeare.*

Let not the piece of virtue,  
Which is set as the cement of our love,  
To keep it builded, be the *ram* to batter  
The fortress of it. *Id.* *Antony and Cleopatra.*

*Ram* thou thy faithful tidings in mine ears,  
That long time have been barren. *Shakspeare.*

Having no artillery nor engines, and finding that  
he could do no good by *ramming* with logs of timber,  
he set one of the gates on fire. *Bacon.*

They mined the walls, laid the powder, and *rammed*  
the mouth, but the citizens made a countermine.

*Huyward.*

Much like a well growne bell weather, or feltred *ram*  
he shews. *Chapman.*

You may draw the bones of a *ram's* head hung  
with strings of beads and ribbands. *Peacham.*

The *ram* having passed the sea, serenely shines,  
And leads the year. *Creech's Manilius.*

This into hollow engines long and round,  
Thick *rammed* at the other bore with touch of fire  
Dilated and infuriate, shall send forth  
Such implements of mischief, as shall dash  
To pieces. *Milton's Paradise Lost.*

A *ram* their offering, and a *ram* their meat.

*Dryden.*

The master bricklayer must try the foundations  
with an iron crow or *rammer*, to see whether the  
foundations are sound. *Moxon.*

Here many poor people roll in vast balls of snow,  
which they *ram* together, and cover from the sun-  
shine. *Addison.*

A ditch drawn between two parallel furrows, was  
filled with some sound materials, and *rammed* to make  
the foundation solid. *Arbuthnot.*

A mariner loading a gun suddenly, while he was  
ramming in a cartridge, the powder took fire, and  
shot the *rammer* out of his hand. *Wiseman.*

**RAM**, in zoology. See **OVIS**.

**RAM**, **BATTERING**, in antiquity, a military  
engine used to batter down the walls of besieged  
places. See **ARTILLERY**.

**RAMA**, or **RAMLA**, a town of Palestine, de-  
scribed by the Arabian geographers in the mid-  
dle ages as the capital of that country. It is  
situated in one of the most fertile districts of  
the Holy Land, though during Dr. Clarke's visit  
it was almost deserted, in consequence of the  
ravages of the plague. It seems doubtful if this  
was the city described under that name in Scrip-  
ture. Rama and Lydda were the two first cities  
of the Holy Land which fell into the hands of  
the crusaders. The former was then in its  
greatest splendor, exceedingly populous, adorned  
with stately buildings, and well fortified. It is  
twenty-five miles W. N. W. of Jerusalem.

**RAMAH**, in ancient geography, a town of  
Benjamin, near Gibeah, called also Ramah of  
Saul (1 Sam. xxii.), six miles north of Jeru-  
salem; memorable for the story of the Levite  
and his concubine: taken and fortified by Baasah  
king of Israel, to annoy the kingdom of Judah.  
This Ramah his mentioned Isa. x. Jer. xxxi. and  
**Math.** ii. and is to be distinguished from

**RAMAH**, or Ramah of Samuel, 1 Sam. xix.  
called also Ramathaim Zophim, 1 Sam. i. 1,  
which lay a great way to the west towards Joppa,  
near Lydda, 1 Maccab. ii., the birth-place of  
Samuel; adjoining to the mountains of Ephraim,  
and the place of his residence, 1 Sam. xv. &c.—  
Josephus.

**RAMAZINI** (Bernardin), an Italian physi-  
cian, born at Carpi, near Modena, in 1633. He  
was professor of physic in the university of  
Modena for eighteen years; and in 1700 accept-  
ed an invitation from Padua, where he was  
made rector of the college; and died in 1714.  
His works were collected and published in Lon-  
don, 1716; of which his treatise *De Morbis*  
*Artificum* is much esteemed.

**RAM'BLE**, *v. n. & n. s.* } Swed. *ramb*;  
**RAM'BLER**. } Lat. *reambulo*. To  
wander; rove irregularly; a wandering excu-  
sion: a rambler is a rover.

This conceit puts us upon the *ramble up and down*  
for relief, till very weariness brings us at last to our-  
selves. *L'Estrange.*

Says the *rambler*, we must e'en beat it out. *Id.*

He that is at liberty to *ramble* in perfect darkness,  
what is his liberty better than if driven up and down  
as a bubble by the wind? *Locke.*

Shame contracts the spirits, fixes the *ramblings*  
of fancy, and gathers the man into himself. *South.*

Chapman has taken advantage of an immeasurable  
length of verse, notwithstanding which, there is  
scarce any paraphrase so loose and *rambling* as his.

*Pope.*

Never ask leave to go abroad, for you will be  
thought an idle *rambling* fellow. *Swift.*

She quits the narrow path of sense  
For a dear *ramble* through impertinence. *Id.*

O'er his ample sides, the *rambling* sprays  
Luxuriant shoot. *Thomson's Spring.*

**RAMBOUILLET**, a town in the department  
of the Seine and Oise, France, has an elegant  
royal castle, situated between two forests, and  
frequently resorted to by the Bourbon princes  
on hunting parties. Rambouillet is also re-  
markable for its breed of Merinos brought here  
in 1787. A canal has been dug from this place  
to Versailles. Population 2600. Thirty miles  
south-west of Paris.

**RAMEAU** (John Philip) a celebrated French  
musician, born at Dijon in 1683. He was made  
organist of the cathedral of Clermont, where he  
wrote most of his works; the chief of which is  
his *Demonstration du Principe de l'Harmonie*,  
1750. He was appointed manager of the opera  
at Paris, and raised to the rank of nobility. He  
died in Paris in 1764.

**RAMESES**, king of the Lower Egypt, who  
Jacob went thither with his family, about A.A.C.  
1706. Ancient authors mention several other  
kings of Egypt of the same name; and it is  
thought that one of those princes erected, in the  
temple of the sun at Thebes, the magnificent  
obelisk which the emperor Constantine caused  
to be removed to Alexandria in the year 334.

**RAMESES**, in ancient geography, a town built  
by the Israelites during their bondage in Egypt,  
and from which the Exodus took place, and  
which must have been towards, and not far from  
the Arabian Gulph, seeing in the third station the  
Israelites arrived on its shore

**RAMIFY** *v. a. & v. n.* } French *ramifier* ;  
**RAMIFICATION**, } Lat. *ramus* and  
**RAMOUS**, *adj.* } *facio*. To make or  
 separate into branches; be parted into branches :  
 ramification is, separation into branches, or the  
 branches separated considered collectively : ram-  
 ous, branchy.

By continuation of profane histories or other mo-  
 numents kept together, the genealogies and *ramifica-*  
*tions* of some single families to a vast extension may  
 be preserved. *Hale.*

The mint, grown to have a pretty thick stalk, with  
 the various and *ramified* roots, which it shot into the  
 water, presented a spectacle not unpleasant to be-  
 hold. *Boyle.*

Which vast contraction and expansion seems un-  
 intelligible, by feigning the particles of air to be  
 springy and *ramous*, or rolled up like hoops, or by  
 any other means than a repulsive power. *Newton.*

A *ramous* efflorescence, of a fine white spar, found  
 hanging from a crust of like spar, at the top of an old  
 wrought cavern. *Woodward.*

As the blood and chyle pass together through the  
*ramifications* of the pulmonary artery, they will be  
 still more perfectly mixed; but if a pipe is divided  
 into branches, and these again subdivided, the red  
 and white liquors, as they pass through the *ramifica-*  
*tions*, will be more intimately mixed; the more *rami-*  
*fications*, the mixture will be the more perfect. *Arlthud.*

Whoever considers the few radical positions which  
 the Scriptures afforded him, will wonder by what  
 energetic operation he expanded them to such ex-  
 tent, and *ramified* them to so much variety, restrained  
 as he was by religious reverence from licentiousness  
 of fiction. *Johnson.*

**RAMILLIES**, or **RAMELIES**, a village of the  
 Netherlands, in South Brabant, famous for the  
 victory obtained 23rd May 1706, by the allied  
 forces under the duke of Marlborough over the  
 French.

**RAMMISSERAM ISLE**, an island in the  
 straits between the continent of Hindostan and  
 Ceylon, eleven miles in length, by six in breadth.  
 It is naturally of little value; but forms the first  
 part of what is believed by the Hindoos to  
 have been a bridge, constructed by their god  
 Ram, for the purpose of conquering Ceylon. It  
 contains a large town called Panban; and a ce-  
 lebrated temple, the entrance to which is through  
 a lofty stone gateway, 100 feet in height. On  
 the stones, many of which are very large, are  
 carved in alto relievo figures of the Hindoo  
 deities. The temple is said to be built in the  
 same massy style, and the architecture resembles  
 the Egyptian; but no European has been permitted  
 to enter it. The image of Ram is bathed every  
 day with water brought 1000 miles from the  
 Ganges, and the concourse of pilgrims is prodig-  
 ious. The rajahs of Tanjore are said to have  
 expended £25,000 in some of their visits: each  
 pilgrim pays according to his ability; and the  
 revenue, after paying the expenses of the temple,  
 becomes the property of a family of Brahmins,  
 the chief of whom is called the pandaram. The  
 strait between the island and the shore is about  
 a mile wide, but is only passable by small ves-  
 sels. Early in the fourteenth century, the Ma-  
 hometans carried their arms into this island, and  
 erected a mosque. The island is now an appen-  
 dage to the district of Ramnad, and pays a small

Vol. XVIII

revenue to the ranee or queen of that place, one  
 of the British tributaries. Long. 79° 21' E.,  
 lat. 9° 17' N.

**RAMMOHUN ROY** (Raja), a Hindoo born  
 at Bourduan, in the presidency of Bengal, in  
 the year 1780, was the first of his nation of any  
 rank that not only abandoned the idolatries of  
 his ancestors, but actually translated portions of  
 the New Testament, and published his views of  
 Christianity at Calcutta. Having acquired much  
 notoriety, and excited a strong interest in the  
 western world, he determined on visiting En-  
 gland, where he met with a reception equal to  
 his most sanguine expectations. He there fully  
 explained his religious opinions, which inclined  
 to Unitarianism; but while he was wisely mind-  
 ful of the chief end of human existence, he was  
 feelingly alive to the best interests of his native  
 country, and pressed his advice for that purpose  
 upon those who had the ability of acting upon  
 it. After a few years passed in England, this  
 accomplished and remarkable person was at-  
 tacked by a fever, at Stapylton Grove, near  
 Bristol, and died, after an illness of but a few  
 days, on the 27th September, 1833.

**RAMNAD**, a trading town and district of the  
 south of India, and province of Marawar. It  
 is governed by a Hindoo family, tributary to the  
 British. The present ruler is a lady, styled the  
 ranee, a considerable part of whose revenue  
 arises from a tax laid upon every pilgrim passing  
 through her territories to the sacred temple of  
 Rammisseram.

**RAMP**, *v. n. & n. s.* } Fr. *ramper*; Ital. *ram-*  
**RAMPAL'LIAN**, *n. s.* } *pare*; Lat. *repo*. To  
**RAMP'ANCY**, } climb. To leap, climb,  
**RAMP'ANT**, *adj.* } or spring: a leap or  
 spring: rampallian is a low sordid wretch: ram-  
 pancy, prevalence; rampant, prevailing; passing  
 beyond restraint; exuberant; the heraldic use is  
 explained below.

They gape upon me with their mouth; as a *ramping*  
 and roaring lion. *Psalm xxii. 13.*

Foaming tarr, their bridles they would champ,  
 And trampling the fine element, would fiercely *ramp*.  
*Spenser.*

He is vaulting variable *ramps*,  
 In your despight, upon your purse. *Shakespeare.*

Away, you scullion, you *rampallion*, you fustilarian.  
*Id.*

Upon a bull, that deadly bellowed,  
 Two horrid lions *rampet*, and seized, and tugged.  
*Chapman.*

The bold Ascalonite  
 Fled from the lion *ramp*, old warriors turned  
 Their plated backs under his heel. *Milton's Agonistes.*

**RAMPANT**, in heraldry, a term applied to a  
 lion, leopard, or other beast that stands on its  
 hind legs, and rears up its fore feet in the pos-  
 ture of climbing, showing only half its face, one  
 eye, &c.

**RAMPART**, or } Fr. *rempart*; Ital.  
**RAM'PIRE**, *n. s. & v. a.* } *ripuro*. An embank-  
 ment or wall round a fortified place; to fortify  
 with such wall.

She felt it, when past preventing, like a river, no  
*rampires* being built against it, till already it have  
 overflowed. *Sidney.*

Set but thy foot  
 Against our *rampired* gates, and they shall ope.  
*Shakpeare.*  
 The marquis directed part of his forces to *rampart*  
 the gates and ruinous places of the walls.  
*Hayward.*  
 Yo' have cut a way for virtue, which our great  
 men  
 Held shut up, with all *ramparts*, for themselves.

*Ben Jonson.*  
 The son of Thetis, *rampire* of our host,  
 Is worth our care to keep. *Dryden.*  
 The Trojans round the place a *rampart* cast,  
 And palisades about the trenches placed. *Id.*  
 He who endeavours to know his duty, and practises  
 what he knows, has the equity of God to stand  
 as a mighty wall or *rampart* between him and dam-  
 nation for any infirmities. *South.*  
 No standards, from the hostile *ramparts* torn,  
 Can any future honours give  
 To the victorious monarch's name. *Prior.*

**RAMPART**, in fortification, an elevated bank  
 of earth raised around a place to resist the ene-  
 my's great shot, and cover the buildings. A  
 parapet is raised upon this bank or elevation,  
 which looks towards the country. It is gene-  
 rally about three fathoms high, and ten or twelve  
 thick; but this depends partly upon the quan-  
 tity of earth which may be taken out of the  
 ditch. A rampart with half moons has advan-  
 tages from being low, because the muskets of the  
 besieged can better reach the bottom of the  
 ditch; but care must be taken that it is not com-  
 manded by the covert-way. A rampart ought  
 to be sloped on both sides; that is, the mass of  
 earth which composes the rampart ought always  
 to be larger at bottom than at top; it should be  
 broad enough to allow the passing of waggons  
 and cannon, independent of the parapet which  
 is raised on it. See **FORTIFICATION**.

**RAMPIONS**, *n. s.* Lat. *rapunculus*. A  
 plant.

*Rampion* is a plant whose tender roots are eaten  
 in the spring, like those of radishes. *Mortimer.*

**RAMPOOR**, a city and extensive district of  
 Hindostan, situated on the banks of the Soosey  
 or Cossila River. It contains the palace of the  
 nabob Fyzoola Khan, and some other good  
 houses; but the greater part of the town contains  
 only sun burnt brick houses, with thatched or  
 tiled roofs. After the conquest of the Rohillas,  
 by the Nabob Shuja Addowla, and the British,  
 in the year 1774 this district, then valued at  
 fourteen lacs of rupees per annum, was ceded  
 to the Nabob Fyzoola Khan, son of Aly Mo-  
 hammed, as a jagier or fief: and under his  
 superintendence it doubled in population and  
 value. He died in 1794 and was succeeded  
 by his eldest son Mohammed Aly, who was very  
 shortly after assassinated by Ghoolaum Moham-  
 med his brother. A British force was in conse-  
 quence sent against him, and, after a severe con-  
 test, succeeded in compelling him to surrender.  
 After this, the jagier was curtailed, and the town,  
 with a revenue of ten lacs of rupees per annum,  
 assigned for the support of the orphan son of the  
 murdered prince. Ram being the name of one  
 of the Hindoo demigods, there are innumerable  
 places called after him.

**RAMSAY** (Allan), a Scottish pastoral poet,  
 was born at Peebles in 1696, and brought up as

a barber in Edinburgh. His songs are in univer-  
 sal esteem; and his dramatic performance, en-  
 titled the Gentle Shepherd, is allowed by the  
 best judges to be unrivalled. Lord Gardenstone  
 says, 'this excellent piece does honor to North  
 Britain. There is no pastoral in the English  
 language comparable to it, and I believe there is  
 none in any language superior.'

**RAMSAY** (Allan), a portrait painter, the son of  
 the preceding, was born at Edinburgh in 1709.  
 He studied at Rome, and on his return settled at  
 Edinburgh; but, after residing there some years,  
 removed to London, and was appointed painter  
 to the king. At the close of life he went to  
 Italy, and died, on landing at Dover, in 1784  
 He wrote a piece, entitled The Present State of  
 the Arts in England, and a volume of essays,  
 called The Investigator.

**RAMSAY** (Andrew Michael), commonly called  
 Chevalier Ramsay, a Scottish writer, born of a  
 good family in Ayr in 1686. He studied at  
 Edinburgh, where he became tutor to the earl of  
 Wemys's son. Travelling afterwards to Leyden,  
 he fell in with one Poiret a mystic divine; on  
 which he went to Paris to consult archbishop  
 Fenelon, who converted him from deism to the  
 Roman Catholic faith in 1709. By this  
 prelate's influence, he was appointed governor to  
 the duke of Chateau Thierry, and the prince of  
 Turenne; and was made a knight of the order of  
 St. Lazarus. He died at St. Germain in 1743  
 in the office of intendant to the duke of Bouil-  
 lon, prince de Turenne. His principal work is  
 the Travels of Cyrus, which has been several  
 times printed in English.

**RAMSAY** (Rev. James), was born at Fraser-  
 burgh, in Aberdeenshire, in 1733. Having stu-  
 died at King's College, Aberdeen, he was bound  
 apprentice to Dr. Findlay, a physician in Fraser-  
 burgh. He afterwards went to London; studied  
 two years under Dr. Macauley; passed the  
 usual trials at surgeons' hall; and then went on  
 board the Arundel, commanded by captain, af-  
 terwards Sir Charles, Middleton (now lord Bar-  
 ham), which was soon after met by a slave ship  
 from Guinea in great distress, an infectious  
 fever having carried off a great number of the  
 crew and slaves, besides the surgeon himself.  
 Ramsay was the only surgeon in the fleet who  
 would venture on board to prescribe for them,  
 and he very fortunately escaped the infection,  
 but broke his thigh bone in getting on board his  
 own ship: this rendered him lame for life. On  
 his return he was recommended to the bishop of  
 London, by whom he was admitted into orders,  
 and immediately sent out to St. Christopher's,  
 where the governor presented him to two recto-  
 ries worth £700 a year. He soon published his  
 Essay on the Treatment and Conversion of the  
 African Slaves in the British Sugar Colonies;  
 and in 1763 married Miss Rebecca Akers, the  
 daughter of a respectable planter. All his exer-  
 tions in favor of the slaves were, however, only  
 productive of opposition, calumny, and acrimo-  
 nious abuse from the planters. Vexed with such  
 unmerited persecution he returned to Britain in  
 1777, visited his native country, where his mo-  
 ther, on whom he had settled an annuity, had  
 died some time before. Being introduced to  
 lord George Germaine, he was, in 1778, ap-

pointed chaplain to admiral Barrington, and afterwards to admiral Rodney; under both of whom he was present at several engagements. After this he took his farewell of St. Christopher's, resigned his benefices, and returned to England in 1781; where he republished his *Essay above-mentioned*. He died July 20th 1789, in his friend Sir C. Middleton's house; leaving a widow and three daughters. He published also at an early period, *An Essay on the Duty and Qualifications of a Sea Officer*; 2. *A Treatise on Signals*; and 3. *A volume of Sea Sermons*. The profits of these works he devoted to the Magdalen and British lying in hospitals, and the marine society.

**RAMSAY** (David), an American physician and historical writer, was a native of Charlestown, South Carolina, and engaged in the practice of medicine at the place of his birth. He was a member of the congress of the United States from 1782 till 1785. Having gone to visit the patients in a lunatic asylum, in 1815, he was unfortunately killed by one of the insane inmates. Dr. Ramsay was the author of *A History of the American Revolution*, so far as respects the State of South Carolina, 1791, 2 vols. 8vo; *The Life of George Washington*, 1807, 8vo. A Discourse delivered on the Anniversary of American Independence, 1800; and, *A View of the Improvements made in Medicine during the Eighteenth Century*, 1802, 8vo.

**RAMSDEN** (Jesse), F. R. S., an eminent optician, was born at Halifax in Yorkshire in 1738, and came to London as an engraver. Having to delineate several mathematical instruments, he finally constructed them himself, and married a daughter of Mr. Dollond, the celebrated optician. He first opened a shop in the Haymarket, whence he removed to Piccadilly, where he remained until his death in 1800. Ramsden early obtained a premium from the board of longitude, for the invention of the curious machine for the division of mathematical instruments hereafter described: he also improved the construction of the theodolite, the pyrometer for measuring the dilatation of bodies by heat, the barometer for measuring the height of mountains, &c.; also the refracting micrometer and transit instrument and quadrant. He made great improvements also in Hadley's quadrant and sextant, and procured a patent for an amended equatorial. Such was his reputation, that his instruments were bespoken in every part of Europe; and ultimately, though he employed sixty men, to obtain the execution of an order was a high favor.

**RAMSDEN'S MACHINE FOR DIVIDING MATHEMATICAL INSTRUMENTS** is an invention of the last century, by which these divisions can be performed with exceedingly great accuracy. On discovering the method of constructing this machine, its inventor, Mr. Ramsden of Piccadilly, received £615 from the Board of Longitude; engaging himself to instruct a certain number of persons, not exceeding ten, in the method of making and using it from the 28th of October 1775 to 28th October 1777; also binding himself to divide all octants and sextants by the same engine, for as long time as

the commissioners should think proper. The following description of the engine is that given by Mr. Ramsden himself. 'This engine consists of a large wheel of bell-metal, supported on a mahogany stand, having three legs, which are strongly connected together by braces, so as to make it perfectly steady. On each leg of the stand is placed a conical friction-pulley, whereon the dividing-wheel rests; to prevent the wheel from sliding off the friction-pulleys, the bell-metal centre under it turns in a socket on the top of the stand. The circumference of the wheel is ratched or cut (by a method which Mr. Ramsden describes) into 2160 teeth, in which an endless screw acts. Six revolutions of the screw will move the wheel a space equal to one degree. Now a circle of brass being fixed on the screw arbor, having its circumference divided into sixty parts, each division will consequently answer to a motion of the wheel of ten seconds, six of them will be equal to a minute, &c. Several different arbors of tempered steel are truly ground into the socket in the centre of the wheel. The upper parts of the arbors that stand above the plane are turned of various sizes, to suit the centres of different pieces of work to be divided. When any instrument is to be divided, the centre of it is very exactly fitted on one of these arbors; and the instrument is fixed down to the plan of the dividing wheel, by means of screws, which fit into holes made in the radii of the wheel for that purpose. The instrument being thus fitted on the plane of the wheel, the frame which carries the dividing-point is connected at one end by finger-screws with the frame which carries the endless screw; while the other end embraces that part of the steel arbor which stands above the instrument to be divided, by an angular notch in a piece of hardened steel; by this means both ends of the frame are kept perfectly steady and free from any shake. The frame carrying the dividing point or tracer is made to slide on the frame which carries the endless screw to any distance from the centre of the wheel, as the radius of the instrument so divided may require, and may there be fastened by tightening two clamps; and the dividing-point or tracer, being connected with the clamps by the double-jointed frame, admits a free and easy motion towards or from the centre for cutting the divisions, without any lateral shake. From what has been said, it appears, that an instrument thus fitted on the dividing-wheel may be moved to any angle by the screw and divided circle on its arbor, and that this angle may be marked on the limb of the instrument with the greatest exactness by the dividing-point or tracer, which can only move in a direct line tending to the centre, and is altogether freed from those inconveniences that attend cutting by means of a straight edge. This method of drawing lines will also prevent any error that might arise from an expansion or contraction of the metal during the time of dividing. The screw frame is fixed on the top of a conical pillar, which turns freely round its axis, and also moves freely towards or from the centre of the wheel, so that the screw-frame may be entirely guided by the frame which connects it with the

centre; by this means any eccentricity of the wheel and the arbor would not produce any error in the dividing; and, by a particular contrivance, the screw when pressed against the teeth of the wheel always moves parallel to itself; so that a line joining the centre of the arbor and the tracer continued, will always make equal angles with the screw.

RAMSEY, a town of Huntingdonshire, sixty-eight miles north of London, and twelve north-east of Huntingdon. It was once famous for a very rich abbey, part of the gatehouse of which is still standing, and a neglected statue of Ailwin, the epitaph of whose tomb, which is reckoned one of the oldest pieces of English sculpture extant, styles him 'kinsman of the famous king Edward, alderman of all England, and the miraculous founder of this abbey.' It was dedicated to St. Dunstan, and its abbots were mitred, and sat in parliament; and so many kings of England were benefactors to it that its yearly rents, says Camden, were £7000. The town was then called Ramsey the Rich; but by the dissolution of the abbey it soon became poor, and even lost its market for many years, which is now held on Saturday. There is a charity school for poor girls.

RAMSEY, a town in the Isle of Man, on the north coast, with a noted and spacious haven.

RAMSGATE, a sea-port town of Kent, in the isle of Thanet, five miles south from Margate, with a very fine pier, seated near the Downs, between the North and South Foreland, ten miles north-east of Canterbury. It was formerly but an obscure fishing village, but since 1688 has been improved and enlarged by a successful trade to Russia and the Baltic, and has become a frequented bathing place. The harbour is very capacious, and was begun in 1750. It is formed by two piers; that to the east is built of Purbeck stone, and extends into the ocean nearly 800 feet before it forms an angle; its breadth on the top is twenty-six feet, including a strong parapet wall. The other, to the west, is constructed of wood as far as the low-water mark, but the rest is of stone. The angles, of which there are five in each pier, consist of 160 feet each, with octagons at the ends of sixty feet diameter, leaving an entrance of 200 feet into the harbour, the depth of which admits of a gradual increase of eighteen to thirty-six feet. It is defended by two batteries. It is now made a royal port in commemoration of his majesty's visit in 1821. After the piers were nearly finished, the deposition of sand within the harbour became so considerable as to threaten its complete destruction, when it was advised by Mr. Smeaton to construct a basin within the harbour, to retain the tide water, and, letting it out again at every ebb, to carry off any deposition by this artificial current. This was accordingly done, and the beneficial effects were such as even to exceed expectation; but as, notwithstanding these improvements, the harbour was found unsafe during easterly gales, an advanced pier was begun in 1787, the utility of which became apparent as the work advanced, and greatly facilitated the entrance of shipping in tempestuous weather. A military road was also completed under the cliff connecting the centre

and outward piers, for the embarkation of troops. About the same period a dry dock was erected, and storehouses for every necessary purpose. A new stone light-house has been since constructed on the head of the west pier, a handsome house for the business of the trustees, another for the residence of the harbour master, a watch-house, &c. From the light-house are displayed in the night, two lamps, with argand burners, when the water in the harbour is of the depth of ten feet; and in the day this notice is given by a flag-staff from Sion Hill. A large stone building has been erected for a dock-house, and a wet dock near the basin, for the repair of vessels; and no cost has been spared to render this harbour as useful as possible, in proportion to the dangerous navigation, in stormy weather, of the adjacent part of the channel. The pier forms the grand promenade. The bathing place, furnished with machines and accommodations in the same manner as at Margate, lies in front of a long line of high chalky rocks at the back of the pier. Warm salt-water, and also plunging and shower baths, are established here, with suitable conveniences. The assembly-room is a neat building, near the harbour; with coffee, tea, billiard, card, and other rooms; the whole being under the direction of the master of the ceremonies at Margate. Here are several good hotels, and numerous lodging-houses suited to every description of company. The libraries in the town are numerous, spacious, and valuable. It has a handsome chapel of ease, besides which there are several meeting-houses. The town is well paved, lighted, and watched, and has a court of requests for the recovery of small debts.

RAMUS, in general, denotes a branch of any thing, as of a tree, an artery, &c. In the anatomy of plants it means the first or lateral branches, which go off from the petiolum, or middle rib of a leaf. The subdivisions of these are called surculi; and the final divisions, into the most minute of all, are by some called capillamenta; but both kinds are generally denominated surculus.

RAMUS (Peter), one of the most celebrated professors of the sixteenth century, was born in Picardy in 1515. A thirst for learning prompted him to go to Paris when very young, and he was admitted a servant in the college of Navarre. Spending the day in waiting on his masters, and the greatest part of the night in study, he made such surprising progress, that when he took his degree of M. A., he offered to maintain a quite opposite doctrine to that of Aristotle. This raised him many enemies; and the two first books he published, *Institutiones Dialecticæ*, and *Aristotelicæ Animadversiones*, occasioned great disturbances in the university of Paris: and the opposition against him was not a little heightened by his deserting the Romish religion, and professing that of the Reformed. Being thus forced to retire from Paris, he visited the universities of Germany, and received great honors wherever he came. He returned to France in 1571, and lost his life miserably in the horrid massacre of St. Bartholemew's day. He published many works which Teissier enumerates.

Much is due to him for having with so much firmness and perseverance asserted the natural freedom of the human understanding. The logic of Ramus obtained great authority in the schools of Germany, Great Britain, Holland, and France; and long and violent contests arose between his followers and those of the Stagyrite, till his fame vanished before that of Descartes.'

**RANA**, the frog, in zoology, a genus belonging to the order amphibia reptilia. The body is naked, furnished with four feet, and without any tail. There are many species. The most remarkable are these :

1. *R. aquatica*, the water frog of Catesby has large black eyes, yellow irides, and long limbs; the upper part of the head and body is of a dusky green, spotted with black; and from each eye to the nose is a white line; and a yellow line along the sides to the rump. They frequent rivulets and ditches, which they do not quit for the dry land. They spring five or six yards at a leap.

2. *R. arborea*, the green tree frog of Catesby, is of a slender shape and bright green color, marked on each side with a line of yellow: the eyes are black; the irides yellow; they have four toes before and five behind; at the end of each toe there is a round membrane, concave beneath, and like the mouth of a leech. They lurk under the lower sides of leaves, even of the tallest trees, and adhere firmly, by means of the membranes at the ends of their toes sticking to the smoothest surface: a looking-glass was held before one, at four yards distance; it reached it at one leap, and stuck closely to it. At night these frogs make an incessant chirping, and leap from spray to spray in search of insects. This species is common to America and the warmer parts of Europe.

3. *R. bufo*, the toad. Ælian and other ancient writers tell many ridiculous fables of the poison of the toad. This animal was believed by some old writers to have a stone in its head fraught with great virtues medical and magical; it was distinguished by the name of the reptile, and called the toad-stone, bufonites, crapaudine, krottenstein. See *Bufo*.

The most full information concerning the nature and qualities of this animal is contained in letters from Mr. Arscott and Mr. Pittfield to Dr. Milles, communicated to Mr. Pennant; concerning a toad that lived above thirty-six years with them, was completely tame, and became so great a favorite that most of the ladies in the neighbourhood got the better of their prejudices so far as to be anxious to see it fed. Its food was insects, such as millepedes, spiders, ants, flies, &c., but it was particularly fond of flesh worms, which were bred on purpose for it. It never appeared in winter, but regularly made its appearance in spring, when the warm weather commenced, climbing up a few steps, and waiting to be taken up, carried into the house, and fed upon a table. Before it attacked the insects, it fixed its eyes on them, and remained motionless for a quarter of a minute, when it seized them by an instantaneous motion of its tongue darted on the insect, with such rapidity that the eye could not follow it,

whereby the insect stuck to the tip of its tongue, and was instantly conveyed to its mouth. This favorite toad at last lost its life, in consequence of being attacked by a tame raven, which picked out one of its eyes; and although the toad was rescued, and lived a year longer, it never recovered its health or spirit. Mr. Pennant's correspondent, among many other particulars, adds, that 'there are thirty males to one female, twelve or fourteen of whom I have seen clinging round a female: I have often disengaged her, and put her to a solitary male to see with what eagerness he would seize her. They impregnate the spawn as it is drawn out in long strings.'

4. *R. cinerea*, the cinereous frog, has a gibbous, cinereous, and smooth back; the belly is yellow and granulated; on each side, from the nose to the rump, there is a white line; and there is the same on the outside of the thighs and legs; the toes are bullated at their ends. They inhabit Carolina.

5. *R. esculenta*, the edible frog, differs from the common frog, in having a high protuberance in the middle of the back, forming a very sharp angle. Its colors are also more vivid, and its marks more distinct; the ground color being a pale or yellowish green, marked with rows of black spots from the head to the rump.

6. *R. ocellata*, the bull frog, a very large species, found in Pennsylvania, and some other parts of North America. The irides are of a dusky red, surrounded with a yellow ring. The auricles are covered with a thin circular skin, which forms a spot behind each eye. They have four toes on the fore feet, and five palmated toes behind. Their color is a dusky brown, mixed with yellowish green, and spotted with black. The belly is yellowish, and faintly spotted. These make a roaring noise like a bull, only more hoarse. Their size is superior to that of any other of the genus, and they can spring forward three yards at a leap; and thus will equal in speed a very good horse at its swiftest course. They live in ponds or bogs with stagnant water; but never frequent streams. In the day time they seldom make any great noise, unless the sky is covered; but in the night time they may be heard at the distance of a mile and a half. When they croak, they are commonly near the surface of the water, under the bushes, and have their heads out of the water. By going slowly, therefore, one may get up almost close to them before they go away. As soon as they are quite under water, they think themselves safe, though it be ever so shallow. These creatures kill and eat young ducklings and goslings, and sometimes carry off chickens that come too near the water; when beaten, they cry out almost like little children. As soon as the air begins to grow a little cool in autumn they hide themselves under the mud in the bottom of stagnant waters, and lie there torpid during the winter. As soon as the weather grows mild towards summer, they begin to get out of their holes and croak. They are supposed by the people of Virginia to be the purifiers of waters, and are respected as the genii of the fountains. Some of them were brought to England alive several years ago.

7. *R. pipal*, the Surinam toad, is more ugly than even the common one. The body is flat and broad; the head small; the jaws, like those of a mole, are extended, and evidently formed for rooting in the ground; the skin of the neck forms a sort of wrinkled collar; the color of the head is of a dark chestnut, and the eyes are small; the back, which is very broad, is of a lightish gray, and seems covered over with a number of small eyes, which are round, and placed at nearly equal distances. These eyes are very different from what they seem: they are the animal's eggs, covered with their shell, and placed there for hatching. These eggs are buried deep in the skin, and in the beginning of incubation but just appear; and are very visible when the young animal is about to burst from its confinement. They are of a reddish shining yellow color; and the spaces between them are full of small warts, resembling pearls. This is their situation previous to their coming forth; but nothing is so surprising as the manner of their production. The eggs, when formed in the ovary, are sent, by some internal canals, which anatomists have not hitherto described, to lie and come to maturity under the bony substance of the back; in this state they are impregnated by the male; the skin, however, is still apparently entire, and forms a very thick covering over the whole brood; but as they advance to maturity, at different intervals one after another, the egg seems to start forward from the back, becomes more yellow, and at last breaks; when the young one puts forth its head; it still, however, keeps its situation until it has acquired a proper degree of strength, and then it leaves the shell, but still continues to keep upon the back of the parent. In this manner the pipal is seen travelling with her wondrous family on her back, in all the different stages of maturity. Some of the strange progeny, not yet come to sufficient perfection, appear quite torpid, and as yet without life in the egg; others seem just beginning to rise through the skin; here peeping forth from the shell, and there having entirely forsaken their prison; some are sporting at large upon the parent's back, and others descending to the ground to try their own fortune below. The male pipal is every way larger than the female, and has the skin less tightly drawn round the body. The whole body is covered with pustules, resembling pearls; and the belly, which is of a bright yellow, seems as if it were sewed up from the throat to the vent, a seam being seen to run in that direction.

8. *R. rubeta*, the natter jack, frequents dry and sandy places; it is found on Putney common, and also near Revesby abbey, Lincolnshire. It never leaps, neither does it crawl with the slow pace of a toad, but its motion is more like running. Several are found commonly together, and, like others of the genus, they appear in the evenings. The upper part of the body is of a dirty yellow, clouded with brown, and covered with porous pimples of unequal sizes; on the back is a yellow line. The upper side of the body is of a paler hue, marked with black spots, which are rather rough. On the fore feet are four divided toes; on the hind five, a little

webbed. The length of the body is two inches and a quarter; the breadth one inch and a quarter; the length of the fore legs one inch and a sixth; of the hind legs two inches. This is the account given by Sir Joseph Banks.

9. *R. temporaria*, the common frog. This is an animal so well known that it needs no description; but some of its properties are very singular. Its spring, or power of taking large leaps, is remarkably great, and it is the best swimmer of all four-footed animals. Its limbs are finely adapted for those ends, the fore members of the body being very lightly made, the hind legs and thighs very long, and furnished with very strong muscles. While in a tadpole state, it is entirely a water animal; and, as soon as the frogs are released from their tadpole state, they immediately take to land; and if the weather has been hot, and there fall any refreshing showers, the ground for a considerable space is perfectly blackened by myriads of these animalcules, seeking for some secure lurking places. Some philosophers, not taking time to examine into this phenomenon, imagined them to have been generated in the clouds, and showered on the earth; but, had they but traced them to the next pool they would have found a better solution of the difficulty. As frogs adhere closely to the backs of their own species, so we know they will do the same by fish. That they will injure, if not entirely kill carp, is a well-known fact. Not many years ago, on fishing a pond belonging to Mr. Pitt of Encomb, Dorsetshire, great numbers of the carp were found each with a frog mounted on it, the hind legs clinging to the back, and the fore legs fixed to the corner of each eye of the fish, which were thin and greatly wasted, teased by carrying so disagreeable a load. These frogs Mr. Pennant supposes to have been males disappointed of a mate. The croaking of frogs is well known; and hence in fenny countries they are distinguished by ludicrous titles: thus they are stiled Dutch Nightingales, and Boston waites. Yet there is a time of the year when they become mute, neither croaking nor opening their mouths for a whole month; this happens in the hot season, and that is in many places known to the country people by the name of the paddock moon. These, as well other reptiles, feed but a small space of the year. Their food is flies, insects, and snails. During winter frogs and toads remain in a torpid state; the last of which will dig into the earth, and cover themselves with almost the same agility as the mole.

10. *R. terrestris*, the land frog of Catesby, has much the appearance of a toad; above it is gray or brown, spotted with dusky; below white, faintly spotted; the irides are red; and the legs short. They frequent the high lands, and are seen most frequently in wet weather and in the hottest time of the day; they leap, feed on insects, particularly the fire-fly and ant. Sometimes the Americans bake and reduce this species to powder, which, mixed with orrize-root, is taken as a cure for a tympany.

RANCAGUA, a province of Chili, between the rivers Maypo and Cachapual, and extending from the Andes to the sea. Its breadth is very unequal, being from seventeen to only eight

leagues. It contains the lakes Aculeu and Bucalemu, and the lands are very fertile in grain. But it is thinly peopled, and the inhabitants, amounting only to 12,000, widely dispersed. It has mines of gold of superior quality.

RANCAGUA, the capital of the above province, also called Santa Cruz de Triana, is situated on the north shore of the river Cachapuel, fifty-three miles south of Santiago.

RANCE (D. A. J. Bouthillier), a learned French writer, born in Paris in 1626. At the age of twelve, so rapid was his progress, he published an edition of Anacreon in Greek, with notes, in 8vo. Having taken his degrees at Sorbonne, he wrote several theological pieces, but gave himself up to dissipation; and at last retired into a monastery, where he died in 1700.

RANCH, *v. a.* Corrupted from wrench. To sprain; to injure with violent contortion. Dryden uses it for to tear.

Against a stump his tusk the monster grinds,  
And *ranch*ed his hips with one continued round.

*Dryden.*

Emeticks *ranch*, and keen catharticks scour.

*Garth.*

RAN'CID, *adj.* Lat. *rancidus*. Strong scented. See RANK.

The oil, with which fishes abound, often turns *rancid*, and lies heavy on the stomach, and affects the very sweat with a *rancid* smell. *Arbutnot.*

RAN'COR, *n. s.* } Old French *rancœur* ;  
RAN'COROUS, *adj.* } Teut. *ranken*. Invet-  
RAN'COROUSLY, *adv.* } rate malignity ; malice ;  
implacability : the adjective and adverb corresponding.

His breast full of *rancor* like canker to freat.

*Tusser.*

As two brave knights in bloody fight  
With deadly *rancor* he enraged found.

*Spenser.*

So flamed his eyen with rage and *rancorous* ire.

*Id.*

*Rancor* will out, proud prelate ; in thy face  
! see thy fury. *Shakspeare. Henry VI.*

Because I cannot

Duck with French nods and apish courtesy,

I must be held a *rancorous* enemy. *Shakspeare.*

Such ambush

Waited with bellish *rancor* imminent.

*Milton.*

No authors draw upon themselves more displeasure than those who deal in political matters, which is justly incurred, considering that spirit of *rancor* and virulence with which works of this nature abound. *Addison's Freeholder.*

Presbyterians and their abettors, who can equally go to a church or conventicle, or such who bear a personal *rancor* towards the clergy. *Swift.*

The most powerful of these were Pharisees and Sadducees ; of whose chief doctrines some notice is taken by the evangelists, as well as of their *rancorous* opposition to the gospel of Christ. *West.*

RANDIA, in botany, a genus of the monogynia order, and pentandria class of plants : CAL. monophyllous : cor. salver-shaped ; berry unilocular, with a capsular rind. There are two species, viz. 1. *R. aculeata* ; and 2. *R. mitis*.

RANDOLPH (Thomas), an eminent English poet of the seventeenth century, born in Northamptonshire in 1605. He was educated at Westminster and Cambridge, and was patronised

by some of the greatest men of his age ; particularly by Ben Jonson. He died in 1634. He wrote, 1. The Muses' Looking-glass, a comedy. 2. Amyntas, or the Impossible Dowry, a pastoral, acted before the king and queen. 3. Aristippus, or the Jovial Philosopher. 4. The Conceited Pedlar. 5. The Jealous Lovers, a comedy. 6. Hey for Honesty, down with Knavery, a comedy ; and several poems.

RANDOLPH (Sir Thomas), LL. D., was born in Kent in 1530. He was a student at Christ-Church, when Henry VIII. turned it into a cathedral. He became principal of Broad-gate Hall in 1549. Under queen Elizabeth he was employed in several embassies to Scotland, France, and Russia ; was knighted, and promoted to several considerable offices. He wrote An Account of his Embassy to the emperor of Russia, anno 1568 ; and Instructions for Searching the Sea and Border of the Coast, from the Pechora to the Eastwards, anno 1588. He died in 1590, aged sixty.

RANDOLPH (Thomas), D. D., was the son of a barrister, the recorder of the city of Canterbury, where he was born about the commencement of the last century ; and went upon the foundation to Corpus Christi College, Oxford, of which society he eventually became president in 1748. Besides the benefices of Petham, Waltham, and Saltwood, all in the immediate neighbourhood of his native city, his distinguished talents as a theologian raised him to the Lady Margaret divinity chair, and the archdeaconry of Oxford, to which latter dignity he was elevated in 1768. He acquired considerable reputation by his Vindication of the Doctrine of the Trinity, &c. A View of the Ministry of our Saviour Jesus Christ. 8vo. 2 vols ; The Christian's Faith a rational Assent ; Citations from the Old Testament contained in the New ; and a volume of Sermons, preached at St. Mary's, Oxford. He died in 1783, leaving behind him two sons.

RANDOLPH (right reverend John), the eldest, afterwards bishop of London, was born in 1749 ; became a student of Corpus Christi College, Oxford ; M. A. 1774 ; B. D. 1782 ; D. D. by diploma 1783 ; prælector of poetry 1776 ; proctor 1781 ; regius professor of Greek 1782 ; and, in the same year, a prebendary of Salisbury ; canon of Christ Church, regius professor of divinity, and rector of Ewelme, in 1783 ; elevated to the bishopric of Oxford in 1799 ; translated to that of Bangor in 1807 ; and thence to London in 1809. He was elected F. R. S. in 1811. He passed a great part of his life in the University of Oxford, and enjoyed a considerable reputation for learning, and it is generally understood that, when he was elevated to the see of Oxford, the university was complimented with the nomination by the crown. By some, however, it has been insinuated that his opinions were somewhat too high and determined, to succeed so very mild and conciliating a prelate as Dr. Porteus. His publications are—A Sermon preached at an Ordination at Christ Church, 1779, 1 Cor. xii. 31. Oxon. 1779, 4to. A Sermon preached at the Consecration of Dr. Lewis Bagot, in 1782, to the bishopric of Bristol, Acts ii. 42. Oxon, 1782, 4to. De Græcæ linguæ studio prælectio habita



in schola linguarum, Oxon. III. Non. Dec. A. D. MDCLXXXII. 1783, 4to. Conscio ad Clerum in Synodo Provinciali Cantuariensis Provinciæ, ad D. Pauli, die 26<sup>o</sup> Novembris, A. D. 1790. A Sermon preached before the Lords spiritual and temporal, in the Abbey Church of Westminster, March 12, 1800, being the day appointed for a general fast. A Sermon preached before the Society for the Propagation of the Gospel in foreign parts, 1803. A Charge delivered to the clergy of the diocese of Bangor, at his primary visitation in 1808, and published at the request of the Clergy. A Charge delivered to the Clergy of the diocese of London, at his Primary Visitation, 1810. The bishop died at Hardham, 28th July, 1813.

**RANDOLPH**, a post town of Orange county, Vermont, twelve miles W. S. W. of Chelsea, twenty-three south of Montpelier, and thirty-eight north of Windsor. This is a pleasant and valuable agricultural town, and has a small village, containing an academy, and a Congregational meeting-house. The town contains a large bed of iron ore. It is watered by the branches of White River, and has valuable mills and iron-works.

**RANDOLPH**, a county in the north-west part of Virginia, bounded north by Monongalia county, east and south-east by Pendleion county, south-west by Greenbrier and Kenhawa counties, and west by Harrison county. It is watered by the head waters of the Monongahela. Chief town, Beverly.

**RANDOLPH**, a county of the central part of New Carolina, a county of Ohio, and of Illinois.

**RAN'DOM**, *n. s. & adj.* Fr. *random*. Want of direction, rule, or method; chance; hazard: done by chance.

For, not to speake

At needy *random*; but my breathe to breake

In sacred oath, Ulysses shall return. *Chapman.*

The striker must be dense, and in its best velocity: the angle which the missive is to mount by, if we will have it go to its furthest *random*, must be the half of a right one; and the figure of the missive must be such as may give scope to the air to bear it.

*Digby.*

Thy words at *random* argue inexperience.

*Milton.*

Fond love his darts at *random* throws,  
And nothing springs from what he sows.

*Waller.*

Virtue borrowed but the arms of chance,  
And struck a *random* blow; 'twas fortune's work,  
And fortune take the praise.

*Dryden.*

In the days of old the birds lived at *random* in a lawless state of anarchy; but in a time they moved for the setting up of a king. *L'Estrange's Fables.*

Who could govern the dependence of one event upon another, if that event happened at *random*, and was not cast into a certain relation to some foregoing purpose to direct?

*South's Sermons.*

'Tis one thing when a person of true merit is drawn as like as we can; and another, when we make a fine thing at *random*, and persuade the next vain creature that 'tis his own likeness.

*Pope.*

Let fortune's gifts at *random* flee,  
They ne'er shall draw a wish frae me,  
Supremely blest wi' love and thee,

In the Birks of Aberfeldy. *Burns.*

Nor will you be sensible of any disadvantage attending it, excepting one, viz. its making you men-

sible of the weakness and ignorance of others, who are often talking in a *random*, inconsequential manner. *Mason.*

**RANDOM-SHOT**, in gunnery, is a shot made when the muzzle of a gun is raised above the horizontal line, and is not designed to shoot directly or point blank. The utmost *random* of any piece is about ten times as far as the bullet will go point-blank. The bullet will go farthest when the piece is mounted to nearly 45° above the level of the range. See **PROJECTILES**.

**RANGE**, *v. a., v. n.* Fr. *ranger*; Dan.

**RAN'GER**, *n. s.* [*& n. s.*] *range*; Welsh *rheng*. To order; place in rank; hence to course or rove over: and, as a verb neuter, rove at large; be placed in order, or in any particular direction: a rank; class; order; step; collection of steps or bars; hence a fire-grate: excursion; compass of excursion or course; hence extent of the course of a ball, in gunnery: a ranger, one that ranges, applied both to dogs and men.

As a roaring lion and a *ranging* bear, so is a wicked ruler over the poor people.

*Proverbs xxviii. 15.*

It was a vault ybuilt for great dispeance,

With many *ranges* reared along the wall,

And one great chimney. *Spenser.*

They walk not widely, as they were woot,

For fear of *raungers* and the great hoot,

But privily prolling to and fro. *Id. Pastoral.*

'Tis better to be lowly horn,

And *range* with humble livers in content,

Than to be perked up in a glistening grief,

And wear a golden sorrow.

*Shakspeare. Henry VIII.*

Cæsar's spirit *rangung* for revenge,

With Ate by his side come hot from hell,

Shall in these confines, with a monarch's voice,

Cry havoc, and let slip the dogs of war.

*Shakspeare.*

You fled

From that great face of war, whose several *ranges*

Frighted each other. *Id. Antony and Cleopatra.*

The implements of the kitchen are spits, *ranges*, cobirons, and pots. *Bacon's Physical Remains.*

Direct my course so right, as with thy hand to show,

Which way thy forests *range*, which way thy rivers flow. *Drayton.*

The buttery must be visible, and we need for our *ranges* a more spacious and luminous kitchen.

*Wotton's Architecture.*

The *range* and compass of Hammond's knowledge filled the whole circle of the arts. *Fell.*

He saw not the marquis till the battle was *ranged*.

*Clarendon.*

The liturgy, practised in England, would kindle that jealousy, as the prologue to that design, and as the first *range* of that ladder which should serve to mount over all their customs. *Id.*

Somewhat raised,

By false presumptuous hope, the *ranged* powers

Disband, and wandering each his several way

Pursues. *Milton.*

Other animals unactive *range*,

And of their doings God takes no account. *Id.*

The next *range* of beings above him are the immaterial intelligences, the next below him is the sensible nature. *Hale.*

Come, says the *ranger*, here's neither honour nor money to be got by staying. *L'Estrange.*

He was bid at his first coming to take off the *range*, and let down the cinders. *Id.*

Their father Tyrrheus did his fodder bring,  
Tyrrheus, chief *ranger* to the Latian king.

*Dryden.*

Men, from the qualities they find united in them,  
and wherein they observe several individuals to  
agree, *range* them into sorts for the convenience of  
comprehensive signs.

*Locke.*

He may take a *range* all the world over, and draw  
in all that wide circumference of sin and vice, and  
center it in his own breast.

*South's Sermons.*

Thanks to my stars, I have not *ranged* about  
The wilds of life, ere I could find a friend.

*Addison.*

From this walk you have a full view of a huge  
*range* of mountains, that lie in the country of the  
Grisons.

*Id.*

The light which passed through its several inter-  
stices, painted so many *ranges* of colours, which were  
parallel and contiguous, and without any mixture of  
white.

*Newton.*

To the copse thy lesser spaniel take,  
Teach him to *range* the ditch and force the brake.

*Guy.*

Let your obsequious *ranger* search around,  
Nor will the roving spy direct in vain,  
But numerous coveys gratify thy pain.

*Id.*

These *ranges* of barren mountains, by condensing  
the vapours and producing rains, fountains, and  
rivers, give the very plains that fertility they boast  
of.

*Bentley's Sermons.*

Far as creation's ample *range* extends,  
The scale of sensual, mental powers ascends.

*Pope.*

A certain form and order, in which we have long  
accustomed ourselves to *range* our ideas, may be best  
for us now, though not originally best in itself.

*Watts.*

**RANGE**, in gunnery, the path of a bullet, or  
the line it describes from the mouth of the  
piece to the point where it lodges. If the piece  
lie in a line parallel to the horizon, it is called  
the right or level range; if it be mounted to  
45°, it is said to have the utmost range; all others  
between 0° and 45° are called the intermediate  
ranges. See PROJECTILES.

**RANGER**, a sworn officer of a forest, appointed  
by the king's letters patent; whose business is to  
drive back the deer out of the purlieus, &c., and  
to present all trespasses within his jurisdiction at  
the next forest court.

**RANGOON**, a city and principal port of the  
Burmhan empire in the province of Pegu. It was  
formerly called Dagoon, and is much celebrated  
in the wars of the Burmhans and Peguers. Stand-  
ing on the north bank of the eastern branch of  
the Irrawaddy, at the distance of thirty miles  
from the sea, this town is almost wholly built of  
wood, and is about a mile in length by half a  
mile broad. At the river gate there is a battery  
erected, with a few pieces of cannon; but the  
place could not stand the fire of a frigate for an  
hour. The streets are narrow, but straight, and  
paved with brick. The houses are raised several  
feet from the ground; and those near the river  
are washed by spring tides. The under story of  
the others are kept clean by hogs, who wander  
about here without any owner. The population  
is said to amount to 30,000, composed of per-  
sons from all parts of the world, after the Burm-  
hans and Peguers. The Chinese are very nu-  
merous and are all carpenters, and obtain  
employment in the dock-yards. The river is

extremely commodious for the construction of  
ships. The spring tides rise twenty feet perpen-  
dicularly. The banks are flat and soft, so that there  
is little occasion for docks, and the shipwrights,  
being active and athletic, turn to good account  
their timber, which is the finest in the world. It  
grows several hundred miles up the country, and  
is cut down during the dry season, and split  
into very thick planks. It is then floated down  
the rivers. It is known that ships can be built  
at Rangoon much cheaper than at Calcutta or  
Bombay. It is therefore resorted to by Euro-  
peans, who, however, generally procure their  
iron work, masts, and capsterns, from other  
places. Vessels of 600 tons burden, however,  
are often entirely constructed at Rangoon. All  
kinds of European goods are imported, and a  
variety of cloths from different parts of India;  
here also are found tea, sugar-candy, and porce-  
lain from China. The exports are chiefly tim-  
ber, wax, and ivory. The police is very exact;  
and, after a certain hour of the night, ropes are  
drawn across the streets and a number of watch-  
men and firemen stationed in different places.  
Two miles and a half from the town stands the  
temple of Shoe Dagoon. In the vicinity are  
several convents, inhabited by the Rahaans, or  
priests, who in general are respectable people;  
and, as the Burmans allow universal toleration,  
there is both a Portuguese and Arminian church  
in the town, which serve for Christians of all  
denominations. Rangoon rose into celebrity on  
the ruin of Pegu in the middle of the last cen-  
tury. It is now the residence of the viceroy of  
the province, and his council, and is considered  
the second city in the Burmhes empire. It has  
frequently been injured by fire: and is the only  
port in the empire which Europeans are allowed  
to settle at or trade with. Long. 96° 9' E., lat.  
16° 47' N.

**RANK**, *n. s., adj. & v. n.* } Sax. nanc; Dar.  
**RANK'LE**, *v. n.* } Belg. and Swed.  
**RANK'LY**, *adv.* } *rank*, of Goth. *rakia*,  
**RANK'NESS**, *n. s.* } to extend.—Thom-  
son. Fr. *rance*; Lat. *rancidus*. High-growing;  
tall; luxuriant; fruitful; strong; str. ng of scent;  
ill-flavored; gross; coarse; festering: rankle is,  
to fester; be inflamed; breed corruption: rankly  
is, coarsely; grossly: rankness corresponding.

Seven ears came up upon one stalk, *rank* and  
good. *Genesis.*

Down with the grasse,  
That groweth in shadow so *ranke* and so stout.

*Tusser.*

Seven thousand broad-tailed sheep grazed on his  
downs;

Three thousand camels his *rank* pastures fed.

*Sandys.*

The storm of his own rage the fool confounds,  
And envy's *rankling* sting the' imprudent wounds.

*Sandys.*

*Rank* smelling rue, and cummin good for eyes.

*Spenser.*

As when two boars with *rankling* malice met,  
Their gory sides fresh bleeding fiercely fret.

*Id.*

It bringeth forth abundantly, through too much  
*rankness*, things less profitable, whereby that which  
principally it should yield, being either prevented in  
place, or defrauded of nourishment, faileth.

*Hooker.*

Who would be out, being before his beloved mistress?

—That should you, if I were your mistress, or I should think my honesty *ranker* than my wit.

*Shakespeare.*

In which disguise,

While other jests are something *rank* on foot,  
Her father hath commanded her to slip  
Away with Slender.

*Id. Merry Wives of Windsor.*

The ewes, being *rank*,  
In the end of Autumn turned to the rams.

*Shakespeare.*

For you, most wicked Sir, whom to call brother  
Would infect my mouth, I do forgive  
Thy *rankest* faults.

*Id. Tempest.*

Beware of yonder dog;  
Look, when he fawns, he bites; and, when he bites,  
His venom tooth will *rankle* to the death.

*Shakespeare.*

'Tis given out, that, sleeping in my garden,  
A serpent stung me: so the whole ear of Denmark  
Is, by a forged process of my death,  
*Rankly* abused.

*Id. Hamlet.*

Begin you to grow upon me; I will physick your  
*rankness*.

*Id. As You Like It.*

Hemp most hugely *rank*.  
Team lastly thither com'n with water is so *rank*,  
As though she would contend with Sabryn.  
Divers sea fowl taste *rank* of the fish on which  
they feed.

*Boyle.*

They fancy that the difference lies in the manner  
of appulse, one being made by a fuller or *ranker* ap-  
pulse than the other.

*Holder.*

This Epiphanius cries out upon as *rank* idolatry,  
and the device of the devil, who always brought in  
idolatry under fair pretences.

*Stillington.*

He the stubborn soil manured,  
With rules of husbandry the *rankness* cured;  
Tamed us to manners.

*Dryden.*

The crane's pride is in the *rankness* of her wing.

*L'Estrange.*

Such animals as feed upon flesh, because such  
kind of food is high and *rank*, quality it; the one by  
swallowing the hair of the beasts they prey upon,  
the other by devouring some part of the feathers of  
the birds they gorge themselves with.

*Ray.*

Where land is *rank*, 'tis not good to sow wheat  
after a fallow.

*Mortimer's Husbandry.*

I have endured the rage of secret grief,  
A malady that burns and *rankles* inward.

*Rowe.*

'Tis pride, *rank* pride, and haughtiness of soul;  
The Romans call it stoicism.

*Addison's Cato.*

The most plentiful season, that gives birth to the  
finest flowers, produces also the *rankest* weeds.

*Addison.*

The drying marshes such a stench convey,  
Such the *rank* steams of reeking Albula.  
Thou shalt feel, enraged with inward pains,  
The hydra's venom *rankling* in thy veins.

*Id.*

This power of the people in Athens, claimed as  
the undoubted privilege of an Athenian born, was  
the *rankest* encroachment, and the grossest degeneracy,  
from the form Solon left.

*Swift.*

Hircina, *rank* with sweat, presumes  
To censure Phillis for perfumes.

*Id. Miscellanies.*

Byzantium's hot-bed better served for use,  
The soil less stubborn, and more *rank* the juice.

*Harte.*

RANK, n. s., v. a. & v. n. Fr. *rang*; Armor.  
*renk*; Wel. *rhenc*. Row or order; line of men  
abreast: class; order; subordination: degree,

and hence high degree of excellence, dignity, or  
eminence: to range; place in any order or class-  
place methodically; be ranged.

West of this place down in the neighbour bottom,  
The *rank* of osiers, by the murmuring stream,  
Left on your right hand brings you to the place.

*Shakespeare.*

Fierce fiery warriors fight upon the clouds,  
In *ranks*, and squadrons, and right form of war,  
Which drizzled blood upon the capitol.

*Id.*

If sour woe delights in fellowship,  
And needly will be *ranked* with other griefs;  
Why followed not, when she said Tybalt's dead,  
Thy father or thy mother?

*Id.*

His horse-troupes, that the vanguard had, he  
strictly did command,  
To ride their horses temperately, to keep their *ranks*,  
and shun

Confusion,

*Chapman.*

Heresy is *ranked* with idolatry and witchcraft.

*Decay of Piety.*

Much is said touching the *ranking* of dignities as  
well temporal as spiritual.

*Selden.*

That state, or condition, by which the nature of  
any thing is advanced to the utmost perfection of  
which it is capable, according to its *rank* and kind,  
is called the chief end or happiness of such a thing.

*Wilkins*

A sylvan scene, and, as the *ranks* ascend  
Shade above shade, a woody theatre.  
In view stood *ranked* of seraphim another row.

*Milton.*

If she walk, in even *ranks* they stand,  
Like some well-marshalled and obsequious band.

*Waller.*

He could through *ranks* of ruin go,  
With storms above and rocks below.

*Dryden's Horace.*

Her charms have made me man, her ravished love  
In *rank* shall place me with the blessed above.

*Dryden.*

The wisdom and goodness of the maker plainly  
appears in the parts of this stupendous fabric, and  
the several degrees and *ranks* of creatures in it.

*Locke.*

He found many of the chief *rank* and figure over-  
whelmed in public and private vices.

*Davenant.*

From straggling mountaineers, for public good,  
Go *rank* in tribes, and quit the savage wood.

*Tate.*

These all are virtues of a meaner *rank*,  
Perfections that are placed in bones and nerves.

*Addison.*

The enchanting power of prosperity over private  
persons is remarkable in relation to great kingdoms,  
where all *ranks* and orders of men, being equally  
concerned in public blessings, equally join in spread-  
ing the infection.

*Atterbury.*

Lepidus's house, which in his consulate was the  
finest in Rome, within thirty-five years was not in  
the hundredth *rank*.

*Arbuthnot.*

'Mong the *ranker* grass

Cull each salubrious plant, with bitter  
Concoctive stored, and potent to allay  
Each vicious ferment.

*Somerville.*

Poets were *ranked* in the class of philosophers  
and the ancients made use of them as preceptors in  
music and morality.

*Broome.*

*Ranking* all things under general and special  
heads renders the nature or uses of a thing more  
easy to be found out, when we seek in what *rank* of  
being it lies.

*Watts's Logic*

Nor *rank* nor sex escapes the general frown,  
But ladies are ript up, and cits knocked down.

*Young.*

Though hereditary wealth, and the rank which goes with it, are too much idolized by creeping sycophants, and the blind adject admirers of power, they are too rashly slighted in shallow speculations of the petulant, assuming, shortsighted, coxcombs of philosophy. *Burke.*

**RANK**, is a straight line made by the soldiers of a battalion or squadron, drawn up side by side: this order was established for the marches, and for regulating the different bodies of troops which compose an army.

**RANK IN THE NAVY.** The admiral, or commander-in-chief of his majesty's fleet, has the rank of a field-marshal; admirals, with their flags on the main-top-mast-head, rank with generals of horse and foot; vice-admirals with lieutenant-generals; rear-admirals as major-generals; commodores, with broad pendants, as brigadier-generals; captains of post-ships, after three years from the date of their first commission, as colonels; other captains, as commanding post-ships, as lieutenant-colonels; captains, not taking post, as majors; lieutenants as captains.

**RANK OF ENGINEERS.** Chief as colonel; director as lieutenant-colonel; sub-director as major; engineer in ordinary, as captain; engineer extraordinary as captain-lieutenant; sub-engineer as lieutenant; practitioner-engineer as ensign.

**RAN'NY**, *n. s.* From run. The shrewmouse.

The mus areneus, the shrewmouse or *ranny*. *Browne.*

**RANSACK**, *v. a.* Sax. *pan*, and Swed. *saka*, to search for or seize.—Johnson. There is also a Goth. and Swed. *ransaka*, and Dan. *ransage*. To plunder; pillage; search; violate.

A covetous spirit,  
Warily awaited day and night,  
From other covetous fiends it to defend,  
Who it to rob and ransack did intend. *Spenser.*  
With greedy force he 'gan the fort assail,  
Whereof he weened possessed soon to be,  
And with rich spoil of ransacked chastity. *Id.*  
Their vow is made to ransack Troy. *Shakespeare.*

Men, by his suggestion taught,  
Ransacked the centre, and, with impious hands,  
Rifled the bowels of the earth. *Milton.*  
The ransacked city, taken by our toils,  
We left, and hither brought the golden spoils. *Druden.*

I ransack the several caverns, and search into the store-houses of water, to find out where that mighty mass of water, which overflowed the earth, is bestowed. *Woodward.*

**RAN'SOM**, *n. s. & v. a.* } Fr. *rançon*;  
**RAN'SOMLESS**, *adj.* } Ital. *ranzon*. Price of redemption from captivity or punishment: to redeem by purchase: ransomeless, without ransome or price.

I will ransom them from the grave, and redeem them from death. *Hosea xiii. 14.*

How is't with Titus Lartius?  
—Condemning some to death and some to exile,  
Hannoming him, or pitying, threat'ning the other. *Shakespeare.*

Ransomeless here we set our prisoners free. *Id.*  
By his captivity in Austria, and the heavy ransom that he paid for his liberty, Richard was hindered to pursue the conquest of Ireland. *Davies on Ireland.*

Has the prince lost his army or his liberty  
Tell me what province they demand for ransom. *Denham.*

Ere the third dawning light  
Return, the stars of morn shall see him rise,  
The ransom paid, which man from death redeems,  
His death for man. *Milton's Paradise Lost.*

To adore that great mystery of divine love, God's sending his only Son into this world to save sinners and to give his life a ransom for them, would be noble exercise for the pens of the greatest wits. *Tillotson.*

This as a ransom Albararle did pay,  
For all the glories of so great a life. *Id.*

**RANT**, *v. a. & n. s.* } Belg. *randen*, to rave,  
**RANT'ER**, *n. s.* } Sco. *ranter*, is a musician. To rave in violent or high sounding language: such language: a ranter, one who uses it  
Nay, an thou'lt mouth, I'll rant as well as thou. *Shakespeare.*

They have attacked me; some with piteous moans,  
Others grinning and only showing their teeth, others  
raunting and hectoring, others scolding and reviling. *Stillingfleet.*

This is a stoical rant, without any foundation in the nature of man or reason of things. *Atterbury.*

Dryden himself, to please a frantic age,  
Was forced to let his judgment stoop to rage;  
To a wild audience he conformed his voice,  
Comply'd to custom, but not erred through choice:  
Deem then the people's, not the writer's sin,  
Almansor's rage, and rants of Maximin. *Granville.*

**RAN'TIPOLE**, *adj. & v. n.* Wantonly formed from rant. Wild; roving; rakish: to rove about. A low word.

What, at years of discretion, and comport yourself at this rantipole rate? *Congreve's Way of the World.*

The eldest was a termagant imperious wench; she used to rantipole about the house, pinch the children, kick the servants, and torture the cats and dogs. *Arbutnot.*

**RANTZAN** (Josias), count, a brave officer, born in Holstein in the beginning of the seventeenth century. He was made a marshal of France and governor of Dunkirk by Louis XIII. He was raised to be commander in-chief of the Danish army, under Frederick I. and Christian III. and by his valor the liberties of his country were secured against the efforts of Christian II. After having lost an eye, an ear, an arm, and a leg, in various battles, he died in 1665.

**RAN'ULA**, *n. s.* Lat. *ranula*.

*Ranula* is a soft swelling, possessing the salivals under the tongue: it is made by congestion, and its progress filleth up the space between the jaws, and maketh a tumour externally under the chin. *Wiseman's Surgery*

**RANUNCULUS**, *n. s.* Fr. *ranuncule*. Crow-foot.

*Ranunculuses* excel all flowers in the richness of their colours: of them there is a great variety. *Mortimer.*

**RANUNCULUS**, crowfoot, a genus of the polygamia order and polyandria class of plants; natural order twenty-sixth, multisiliquæ: CAL. pentaphyllous; petals five, each with a melliferous pore on the inside of the beel; the seeds naked. There are upwards of sixty different species of

this genus, six or eight of which claim general esteem as flowery plants for ornamenting the gardens, and a great number are common weeds in the fields, waters, and pasture ground. Of the garden kinds the principal sort is the Asiatic or Turkey and Persian ranunculus, which comprises many hundred varieties of large, double, most beautiful flowers of various colors; but several other species, having varieties with fine double flowers, make a good appearance in a collection, though as those of each species consist only of one color, some white, others yellow, they are inferior to the Asiatic ranunculus, which is large, and diversified a thousand ways in rich colors, in different varieties. However, the garden kinds in general effect a very agreeable diversity in assemblage in the flower compartments, &c., and they being all very hardy, succeed in any open beds and borders, &c.

1. *R. Asiatica*. The Asiatic species in all its varieties will succeed in any light, rich, garden earth; but the florist often prepares a particular compost for the fine varieties, consisting of good garden mould or pasture earth, sward and all, with a fourth part of rotted cow dung, and the like portion of sea sand; and with this they prepare beds four feet wide and two deep: however, in default of such compost, use beds of any good light earth; or, it may be made light and rich with a portion of drift sand and rotten cow-dung; they will also thrive in beds of well wrought kitchen garden earth, and they often prosper in common flower borders. The seasons for planting the roots are in autumn and spring; the autumn plantings generally flower strongest and soonest by a month at least, and are succeeded by the spring planting in May and June. The autumnal planting is performed in October and early part of November. Some plant in the end of September to have a very early bloom; but those planted in that month and beginning of October often come up with rank leaves soon after, in winter, so as to require protection in hard frosts; those, however, planted about the middle or end of October, and beginning of November, rarely shoot up strong till towards spring, and will not require so much care of covering during winter; and the spring planting may be performed in the end of January or beginning of February as soon as the weather is settled; they will not require any covering. Thus by two or three different plantings may be obtained a succession of these beautiful flowers in constant bloom from April till the middle of June; but the autumnal plants, for the general part, not only flower strongest, but the roots increase more in size, and furnish the best off-sets for propagation. Prepare for the choicer sorts four-feet beds of light earth, and rake the surface smooth: then plant the roots in rows lengthwise the beds, either by drilling them in two inches deep, and six inches distance in the row, and the rows six or eight asunder; or plant them by bedding-in, or by dibble-planting, the same depth and distance. Those designed for the borders should be planted generally towards the spring, in little clumps or patches, three, four, or five roots in each, putting them in either with a dibble or trowel, two or three inches deep,

and three or four asunder in each patch, and the patches from about three to five or ten feet distance, placing them rather forward in the border. All the varieties of this species propagate abundantly by off-sets from the root, and new varieties are gained by seed. 1. By off-sets. The time for separating the off-sets is in summer, when the flower is past, and the leaves and stalks are withered: then, taking up all the roots in dry weather, separate the off-sets from each main root, and, after drying the whole gradually in some shady airy room, put them up in bags till the autumn and spring seasons of planting; then plant them as before, placing all the off-sets in separate beds: many of them will blow the first year, but in the second they will all flower in perfection. 2. By seed. Save a quantity of seed from the finest semi-double flowers, and sow it either in August, March, or April; it should be sowed in light rich mould, either in pots or in an east border, drawing very shallow flat drills five or six inches asunder, in which sow the seeds thinly, and cover them lightly with earth, giving frequent refreshments of water in dry weather, and in a month or six weeks the plants will rise with small leaves; continue the light waterings in dry weather, to preserve the soil moist during their summer's growth to increase the size of the roots; and in June, when the leaves decay, take up the roots and preserve them till the season for planting; then plant them in common beds, and they will flower the spring following, when all the doubles of good properties should be marked, and the singles thrown away. The juice of many species of ranunculus is so acrid as to raise blisters on the skin, and yet the roots may be eaten with safety when boiled.

RAP, *v. a. & n. s.* Sax. *ræppan*; Dan. and Swed. *rap*. To strike with a quick smart blow; utter hastily: a quick smart blow.

Knock me at this gate  
And rap me well, or I'll knock your knave's pate.  
*Shakspeare.*

With one great peal they rap the door,  
Like footmen on a visiting day. *Prior.*  
He was provoked in the spirit of magistracy, upon discovering a judge, who rapped out a great oath at his footman. *Addison.*

They that will not be counselled cannot be helped, and, if you will not hear reason, she will surely rap your knuckles. *Franklin.*

RAP, *v. a.* From Lat. *rapio*. To snatch away; seize; affect with rapture; strike with extasy.

These are speeches of men not comforted with the hope of that they desire, but rapped with admiration at the view of enjoyed bliss. *Hooker.*

He leaves the welkin way most beaten plain,  
And rapt with whirling wheels, inflames the skyen,  
With fire not made to burn, but fairly for to shyne.  
*Spenser.*

What thus raps you? are you well?  
*Shakspeare.*

The government I cast upon my brother,  
And to my state grew stranger, being transported  
And rapt in secret studies. *Id.*

The rocks that did more high their foreheads raise  
To his rapt eye. *Chapman.*

You may safe approve,  
How strong in instigation to your love  
Their rapting tunes are. *Chapman's Ulysey.*

**Adulterous Jour**, the king of Membrant, *raped*  
Fair Josian his dear love. *Drayton.*

Underneath a bright sea flowed  
Of jasper, or of liquid pearl, whereon  
Who after came from earth, sailing arrived  
Wasted by angels, or flew o'er the lake  
*Rapt* in a chariot drawn by fiery steeds.

*Milton.*

Their husbands robbed, and made hard shifts  
To' administer unto their gifts  
All they could *rap* and *rend* and pilfer,  
To scraps and ends of gold and silver. *Hudibras.*  
I'm *rapt* with joy to see my Mercia's tears.

*Addison's Cato.*

How comest thou to go with thy arm tied up? has  
old Lewis given thee a *rap* over thy fingers' ends?

*Arbutnot.*

It is impossible duly to consider these things,  
without being *rapt* into admiration of the infinite  
wisdom of the divine architect. *Cheyne.*

*Rapt* into future times, the bard begun,  
A virgin shall conceive, a virgin bear a son!

*Pope.*

**RAPA'CIOUS**, *adj.* } *Fr. rapace*; *Lat.*  
**RAPA'CIOUSLY**, *adv.* } *rapax*. Given to plun-  
**RAPA'CIOUSNESS**, *n. s.* } der or violence: the  
**RAPACITY**. } adverb and noun sub-

stantives corresponding.

Well may thy Lord, appeased,  
Redeem thee quite from death's *rapacious* claim.

*Milton.*

Any of these, without regarding the pains of  
churchmen, grudge them those small remains of an-  
cient piety which the *rapacity* of some ages has  
scarce left to the church. *Sprat.*

Soon heightened by the diamond's circling rays,  
On that *rapacious* hand for ever blaze? *Pope.*

**RAPE**, *n. s.* Sax. *pape*; Goth. and Swed *rep*.  
A bunch or cluster. See **ROPE**.

The juice of grapes is drawn as well from the *rape*,  
or whole grapes plucked from the cluster, and wine  
poured upon them in a vessel, as from a vat, where  
they are bruised. *Ray.*

**RAPE**, *n. s.* *Fr. rapt*; *Lat. raptus, rapio*.  
Act of taking away; violent defloration of cha-  
stity; something snatched or taken violently.

Where now are all my hopes! oh never more  
Shall they revive! nor death her *rapes* restore!

*Sandys.*

You are both decyphered  
For villains marked with *rape*.

*Shakspeare. Titus Andronicus.*

The parliament conceived that the obtaining of  
women by force into possession, howsoever afterwards  
assent might follow by allurements, was but a *rape*  
drawn forth in length, because the first force drew on  
all the rest. *Bacon's Henry VII.*

Pear grew after pear,  
Fig after fig came; time made never *rape*.  
Of any dainty there. *Chapman's Odyssey.*

Witness that night

In Gibeah, when the hospitable door  
Exposed a matron, to avoid worse *rape*. *Milton.*

Tell the Thracian tyrant's altered shape,  
And dire revenge of Philomela's *rape*.

*Roscommon.*

The haughty fair  
Who not the *rape* ev'n of a god could bear.

*Dryden.*

**RAPE OF WOMEN**, in English law, from *rapio*.  
An unlawful and carnal knowledge of a woman,  
by force, and against her will; which is felony

by the common and statute law. Co. Litt. 190  
The word *rapuit* (ravished) is so appropriated  
by law to this offence, that it cannot be ex-  
pressed by any other; even the word carnaliter  
cognovit, &c., without it, will not be sufficient.  
Co. Litt. 124. 2 Inst. 180.

Rape was punished by the Saxon laws, parti-  
cularly those of king Athelstan, with death; but  
this was afterwards thought too hard, and in  
its stead another severe, but not capital punish-  
ment was inflicted by William the Conqueror,  
viz. castration and loss of eyes; which contin-  
ued till after Bracton wrote, in the reign of  
Henry III. But, in order to prevent malicious  
accusations, it was then the law that the woman  
should immediately after 'dum recens fuerit  
maleficium,' go to the next town, and there  
make discovery to some credible persons of the  
injury she has suffered: and afterwards should  
acquaint the high constable of the hundred, the  
coroners, and the sheriff with the outrage. Af-  
terwards, by statute Westm. c. 13, the time of  
limitation was extended to forty days. At pre-  
sent there is no time of limitation fixed; for, as  
it is usually punished by indictment at the suit  
of the king, the maxim of law takes place that  
nullum tempus occurrit regi: but the jury will  
rarely give credit to a stale complaint. During  
the former period also it was held for law, that  
the woman (by consent of the judge and her  
parents) might redeem the offender from the  
execution of his sentence, by accepting him for  
her husband; if he also was willing to agree to  
the exchange, not otherwise. But this is now  
not held for law; and it is said that the election  
of the woman is taken away by the stat. Westm.  
2, making the rape felony, although she consent  
afterwards.

By stat. Westm. 1, 3 Ed. I. c. 13, the punish-  
ment of rape was much mitigated: the offence  
itself being reduced to a trespass, if not prose-  
cuted by appeal within forty days, and subject-  
ing the offender only to two years' imprison-  
ment, and a fine at the king's will. But, this  
lenity being productive of terrible consequences,  
it was soon found necessary to make the offence  
of forcible rape felony, which was accordingly  
done by stat. Westm. 2, 13 Ed. III. c. 34. And  
by stat. 18 Eliz. c. 7, it is made felony without  
benefit of clergy: as is also the abominable  
wickedness of carnally knowing and abusing  
any woman child under the age of ten years; in  
which case the consent or non-consent is immat-  
terial, as by reason of her tender years she is  
incapable of judgment and discretion.

Hale is of opinion that such profligate ac-  
tions committed on an infant under the age of  
twelve years, the age of female discretion by the  
common law, either with or without consent,  
amount to rape and felony; as well since as  
before the statute of queen Elizabeth, 1 Hal.  
P. C. 631. That law, however, has in general  
been held only to extend to infants under ten;  
though it should seem that damsels between ten  
and twelve are still under the protection of the  
stat. Westm. 1, the law with respect to their se-  
duction not having been altered by either of the  
subsequent statutes. 4 Comm. c. 15.

A male infant under the age of fourteen years

is presumed by law incapable to commit a rape; and, therefore, it seems, cannot be found guilty of it. For though in other felonies *malitia supplet etatem*, yet, as to this particular species of felony, the law supposes an imbecillity of body as well as mind. 1 Hal. P. C. 631. But it is no excuse or mitigation of the crime, that the woman at last yielded to the violence, and consented either after the fact or before, if such consent was forced by fear of death or duress; or that she was a common strumpet, for she is still under the protection of the law, and may be forced: but it was anciently held to be no rape to force a man's own concubine; and it is said by some to be evidence of a woman's consent, if at she was a common whore. Also, formerly, it was adjudged not to be a rape to force a woman, who conceived at the time; because it was imagined that, if she had not consented, she could not have conceived: though this opinion has been since questioned, by reason the previous violence is no way extenuated by such a subsequent consent: and if it were necessary to show the woman did not conceive, to make the crime, the offender could not be tried till such time as it might appear whether she did or not. 2 Inst. 190.

As to the facts requisite to be given in evidence and proved upon an indictment of rape, they are of such a nature, that though necessary to be known and settled, they are highly improper to be publicly discussed, except in a court of justice. And Mr. Peel has recently simplified the evidence necessary to be given there. Judge Hale observes that, though a rape is a most detestable crime, it is an accusation easily made, and hard to be proved; but harder to be defended by the man accused, although ever so innocent: and he mentions several instances of rapes, which at the time were apparently fully proved, but were afterwards discovered to have been malicious contrivances. 1 Hales's Hist. P. C. 625. 636. Aiders and abettors may be indicted as principal felons.

**RAPHAEL, RAFFAELLE, OR RAFFAELLO SANZIO**, the most eminent of modern painters, was born at Urbino in 1483, being the son of a painter of no great reputation. He however cultivated with care the talents which his son Raphael exhibited at an early age, and was soon repaid by the assistance which he afforded him in several of his pieces. But, finding that the talents of his son merited still more skilful instruction, he placed him under the care of Carvadini, better known by the name of Carnevale, till he was sufficiently advanced to be received into the school of Pietro Perugino.

This master was then in very high esteem, though his style was dry and meagre, in comparison with that of Masaccio, and others of the Florentine school. Raphael therefore soon became the rival, rather than the pupil of this artist. His aptitude enabled him quickly to acquire his master's manner in the most perfect degree. Vasari speaks of an Assumption of the Virgin, painted at this period by Raphael, as being wrought with extreme beauty, and precisely like the work of Perugino.

In 1499, being then only sixteen years of age,

he quitted Perugino, and began soon after to execute designs of his own for the churches, and private persons. Among those early productions of his genius are, the Crowning of the Virgin, in the convent of the Eremitani; the Crucifixion in the Dominican church, at Citta di Castello; and a Holy Family at Formio, in which the Virgin is represented as lifting a veil from the Infant who is asleep. About this time, his friend and fellow pupil, Pinturicchio, being employed by cardinal Piccolomini to ornament the library at Sienna, requested Raphael to become his co-adjutor in that work. He assented, and the two artists began there ten large pictures, illustrative of the history of Pope Pius II., and Raphael drew the sketches and cartoons for the whole work. Previous to the completion of these paintings, however, he visited Florence, where the performances of Masaccio and Lionardo da Vinci attracted his attention, and contributed considerably to his improvement. In this city he also became acquainted with Fra Bartolomeo di St. Marco, who instructed him in the principles of coloring, and the *chiaro-oscuro*, for which in return Raphael taught his friend the rules and practice of perspective. After a short stay at Florence, the death of his father obliged him to return to Urbino, where the duke engaged him to paint four pictures for his palace, which were much valued. In 1505 he removed to Perugia, being engaged there to paint the chapel of St. Severo; and a crucifixion in the Camaldolian monastery. The latter he executed himself, but the former work he left to be completed by his old master; in order that he might return to Florence, for the continuance of his studies, well persuaded that he had yet much to learn. He remained at Florence nearly two years, during which period he painted the Virgin with the Infant and St. John, for the ducal gallery; and the Entombing of Christ, for the Franciscan church of Perugia. The reputation which Raphael acquired by these productions having reached Rome, he was invited thither by pope Julius II., who was at that time engaged in ornamenting the Vatican. At the beginning of 1508, the young Raphael presented himself to the pontiff, by whom he was cordially received, and immediately employed in painting a superb suite of apartments called *La Segnatura*. Here he began a set of pictures emblematical of theology, philosophy, poetry, and jurisprudence, the design of which so much pleased the pope that he ordered all the paintings on the walls of his palace to be obliterated, and replaced by the productions of Raphael. The works of former masters accordingly disappeared, with the exception of one piece by Perugino, which was saved through the earnest intercession of Raphael, out of respect to his old friend and preceptor. He was also employed by the rich banker, Agostino Chigi, for whose family chapel he painted some of his most beautiful pieces; but his passion for a beautiful young woman, the daughter of a baker, who thence took the name of *La Bella Fornarina*, causing him to withdraw to her house, Chigi invited her to his palace, that the painter might continue his work without interruption. The painting of these rooms, which occupied nine years, was com-

pleted in 1517, and they obtained the name, which they still retain of the stanze of Raphael: he within the same period also painted the principal events in the history of Constantine; twelve whole length figures of the apostles; and several small pictures for the ceilings of the palace. He also found time to study architecture under his uncle Bramante, whom he succeeded in 1515, as superintendent of the building of St. Peter's church, with a salary of 300 gold crowns. The same year Raphael accompanied the pope to Florence, where he constructed a design for the façade of the church of St. Lorenzo: and another of a palace for the bishop of Troja. He also designed the Caffarelli palace at Rome, another for the marquis della Salticella; a villa for the cardinal Giulio de Medici; a set of stables for the prince Ghigi; and a chapel in the church of St. Mario del Popolo. When he had completed the painting of the three principal apartments of the Vatican, his powers were directed to the decoration of the arcades, now known by the name of the Loggie, the architecture of which, though begun by Bramante, was finished by his nephew. Here Raphael and his assistants painted thirteen ceilings, each containing four subjects taken from sacred history, the whole having been designed by himself. The entire series has been engraved, and is commonly known by the title of Raphael's Bible. About the same period he also designed the celebrated Cartoons for the tapestry hangings of the papal chapel. These designs, after having been wrought in Flanders, were bought by Charles I., and have long formed a part of the royal collections at Hampton Court. They have been engraved more than once, and recently in the first style by Mr. Holloway, after the laborious application of many years. Besides his works in the Vatican, Ra-

phael executed a number of frescoes, the Farnesina, where he painted the Triumph of Galatea, and designed a set of pictures of the Loves of Cupid and Psyche. Of his pieces in oil, the principal are a St. Cecilia, painted for the church of St. Giovanni in Monte, at Bologna; Christ carrying the Cross, which is, or was, in the royal collection at Madrid; St. Margaret and St. George now in the Louvre; St. John in the Desert; and a Holy Family, in the same repository; and a Virgin with the Child in her lap at Loretto. The last, and perhaps the greatest work of this celebrated artist is the Transfiguration of Christ, which he painted for the cardinal de Medici. At the foot of Mount Tabor is an assembled multitude, among whom are some of the disciples endeavouring in vain to relieve a youth from the dominion of an evil spirit. The various emotions of the different parties in this groupe are most characteristic; but the mind is soon carried beyond the touching scene below to the more sublime one above, where Christ appears elevated in the air, surrounded with glory, between Moses and Elias, while the three favored apostles kneel in devout astonishment on the ground. With this great work the labors and life of the painter terminated; for while engaged upon it he was attacked by a disease, which, for want of proper treatment, carried him off on Good Friday, April 7th, 1520, when he had just completed his thirty-seventh year. His body lay in state in the room where he had been accustomed to study, and the picture of the Transfiguration was placed near the bier. The funeral was conducted with great pomp at the Pantheon, and cardinal Bembo, by the desire of the pope, wrote the following inscription for the tomb, which was soon afterwards erected to the memory of Raphael:

D. O. M.

RAPHAELI SANCTIO JOAN. F. URBINATI,  
 PICTORI EMINENTISS. VETERUMQUE ÆMULO,  
 CUJUS SPIRANTEIS PROPE IMAGINEIS SI  
 CONTEMPLARE NATURÆ ATQUE ARTIS FŒDUS FACILE  
 INSPEXERIS.

JULII II. ET LEONIS X. PONT. MAX. PICTURÆ  
 ET ARCHITECT. OPERIBUS GLORIAM AUXIT.  
 VIXIT. A. XXXVII. INTEGER INTEGROS  
 QUO DIE NATUS EST, EO ESSE DESIIT.

VII. ID. APRIL. M.D.XX.

ILLE HIC EST RAPHAEL, TIMUIT QUO SOSPITE VINCI  
 RERUM MAGNA PARENS, ET MORIENTE MORI.

Raphael was of a mild and amiable character; but his immoderate attachment to his art induced him to decline matrimony, though cardinal Bibliena offered him one of his nieces. 'General opinion,' says Fuseli, 'has placed Raphael at the head of his art, not because he possessed a decided superiority over every other painter in every branch, but because no other artist ever united with his own peculiar excellence all the other parts of the art in an equal degree with him. The drama, or the representation of character in conflict with passion, was his sphere; to represent which, his invention in the choice of the moment, his composition in the arrangement of his actors, and his expres-

sion in the delineation of their emotions, were and perhaps ever will be, unrivalled. To this he added a style of design dictated by the subject, a color correspondent thereto, all the grace which propriety permitted or sentiment suggested, and as much chiaro-oscuro as was compatible with his desire of perspicuity. It is therefore only when he forsook the drama to make excursions into the pure epic or sublime, that his forms became inadequate, and inferior to those of Michael Angelo. It is only in subjects where color becomes the ruling principle that he is excelled by Titian; and he yields to Corregio only in that grace and chiaro-oscuro which is less the minister of propriety and sen-



timent than its charming abuse or voluptuous excess, and sacrifices to the eye what is claimed by the mind.'

**RAPHAÏM**, or **REPHAÏM**, a name mentioned by Moses, signifying Giants, as they really were, and an actual people too, situated in Basan or Batanea, beyond Jordan, separated from the Zanzummim by the river Jabkok. Also a valley near Jerusalem, Joshua x.

**RAPHANUS**, radish, a genus of the siliquosa order, and tetradynamia class of plants; natural order thirty-ninth, siliquosæ: CAL. close; the siliqua torose, or swelling out in knots, subarticulated, and round. There are two melliferous glandules between the shorter stamina and the pistil, and two between the longer stamina and the calyx. There is only one species, viz.

*R. sativus*, the common garden radish, of which there are several varieties. They are annual plants, which, being sowed in spring, attain perfection in two or three months, and shoot up soon after into stalk for flower and seed, which, ripening in autumn, the whole plant, root and top, perishes; so that a fresh supply must be raised annually from seed in the spring, performing the sowings at several different times, from about Christmas until May, to continue a regular succession of young tender radishes throughout the season: allowing only a fortnight or three weeks interval between the sowings; for one crop will not continue good longer than that space of time, before they will either run to seed, or become tough, sticky, and too hot to eat.

**RAPHELENGIUS** (Francis), a learned French orientalist, born at Laney, near Lisle, in 1539. He studied Greek and Hebrew at Paris; but, the civil wars breaking out, he came to England, and taught Greek at Cambridge. He afterwards went to the Netherlands, and corrected the press for the celebrated Plantin. He was afterwards appointed professor of Hebrew and Arabic in the university of Leyden. He published a Chaldaic Dictionary, an Arabic Lexicon, and a Hebrew Grammar, which are much esteemed. He died in 1597, aged fifty-eight.

**RAPHIDIA**, in entomology, a genus of insects of the neuroptera order. See ENTOMOLOGY. The most remarkable species is the

*R. ophiopsis*. It has an oblong head, shaped like a heart, with its point joined to the thorax, and the broad part before. It is smooth, black, flattened, continually shaking, with short antennæ, yellowish maxillæ, and four palpi. Towards the middle of the upper part of the head, between the eyes are, the three stemmata, placed to a triangle. The thorax, to which this head is fastened, is narrow, long, and cylindrical. The abdomen, broader, is black like the rest of the body, with the segments margined yellow. The feet are of a yellowish cast. The wings, which are fastigated, are white, diaphanous, veined, and as it were covered with a very fine network of black. This insect, in the figure of its head, resembles a snake. It is found but seldom, and in woods only.

**RAPHOE**, a dilapidated village of Ireland, in the county of Donegal, but an ancient episco-

pal see; the bishop of which is suffragan of Armagh. The cathedral was erected in the eleventh century. The episcopal castle was built in the reign of Charles I. at the expense of government. In the rebellion of 1641 it stood a long and vigorous siege; it has been since modernised. Twenty-one miles north-east of Donegal, and eleven south-west of Londonderry.

**RAP'ID**, *adj.* } Fr. *rapide*; Lat. *rapidus*.  
**RAP'IDLY**, *adv.* } Quick; swift: the adverb  
**RAPID'ITY**, *n. s.* } and noun substantive cor-  
**RAP'IDNESS**. } responding

Part shun the goal with *rapid* wheels.

*Milton.*

While you so smoothly turn and rowl our sphere,  
 That *rapid* motion does but rest appear. *Dryden.*

Where the words are not monosyllables, we make them so by our *rapidity* of pronunciation. *Addison.*

To the lascivious pipe and wanton song,  
 That charm down fear, they frolic it along,  
 With mad *rapidity* and unconcern,  
 Down to the gulf, from which is no return.

*Cowper.*

**RAP'IER**, *n. s.* } Fr. *rapiere*; Teut. *rapier*,  
**RAP'IER-FISH**. } so called from the quick-  
 ness of its motion. A small thrusting sword:  
 for rapier-fish see below.

I will turn thy falsehood to thy heart,  
 Where it was forged, with my *rapier's* point.

*Shakespeare.*

The *rapier-fish*, called xiphias, grows sometimes to the length of five yards: the sword, which grows level from the snout of the fish, is here about a yard long, at the basis four inches over, two-edged, and pointed exactly like a *rapier*: he preys on fishes, having first stabbed them with this sword. *Grew.*

A soldier of far inferior strength may manage a *rapier* or fire-arms so expertly as to be an overmatch for his adversary. *Pope.*

**RAPIER** formerly signified a long old fashioned sword, such as those worn by the common soldiers; but it now denotes a small sword, as contradistinguished from a broad sword.

**RAPIN** (Nicholas), an eminent French poet, born at Fontaney Le Comte, about 1540. He was made grand prevot by Henry III., displaced by the Leaguers, being a Protestant, but restored by Henry IV. Some of his best pieces are to be found in the *Delices des Poetes Latins de France*. He died at Fontaney in 1609.

**RAPIN** (Renatus), a Jesuit and eminent French writer, was born at Tours in 1621. He taught polite literature in the society of the Jesuits with great applause, and was justly esteemed one of the best Latin poets of his time. He died in Paris in 1687. He wrote, 1. A great number of Latin poems, which have rendered him famous throughout all Europe; among which are his *Hortorum Libri Quatuor*, reckoned his masterpiece. 2. *Reflections on Eloquence, Poetry, History, and Philosophy*. 3. *Comparisons between Virgil and Homer, Demosthenes and Cicero, Plato and Aristotle, Thucydides and Titus Livius*. 4. *The History of Jansenism*. 5. Several works on religious subjects. The best edition of his Latin poems is that of Paris in 1723, in 3 vols. 12mo.

**RAPIN DE THOYRAS** (Paul de), a celebrated historian, the son of James Rapin, lord of Thoyras, was born at Castres in 1661. After being educated under a tutor in his father's house, he was sent to Puy Laurens, and thence to Saumur. In 1669 he returned to his father, studied the law, and was admitted an advocate: but, reflecting that his being a Protestant would prevent his advancement at the bar, he resolved to quit the law, and apply himself to the sword; but his father would not consent to it. The revocation of the edict of Nantes in 1685, and the death of his father, which happened two months after, made him come to England; but he soon after went to Holland, and enlisted himself in the company of French volunteers at Utrecht, commanded by M. Rapin, his cousin-german. He attended the prince of Orange into England in 1688; and in 1689 lord Kingston made him an ensign in his regiment, with which he went into Ireland, where he gained the esteem of his officers at the siege of Carrickfergus, and had soon a lieutenant's commission. He was present at the battle of the Boyne, and was shot through the shoulder at the siege of Limerick. He was soon after captain of the company in which he had been ensign; but, in 1693, resigned it to one of his brothers, in order to be tutor to the earl of Portland's son. In 1699 he married Marianne Testard; but this neither abated his care of his pupil, nor prevented his accompanying him in his travels. Having finished his employment, he returned to his family, which he had settled at the Hague; and here he continued some years. But, as he found his family increase, he resolved to retire to some cheap country; and accordingly removed, in 1707, to Wesel, where he wrote his History of England, and some other pieces. Though he was of a strong constitution, yet seventeen years close application (in composing that history) entirely ruined his health. He died in 1725. He wrote in French, 1. A Dissertation on the Whigs and Tories. 2. His History of England, printed at the Hague in 1726 and 1727, in 9 vols., 4to., and reprinted at Trevoux in 1728, in 10 vols. 4to. This last edition is more complete than that of the Hague. It has been translated into English, and improved with notes, by the Rev. Mr. Tindal, in 2 vols. folio. Lord Gardenstone observes, that 'Mr. Hume has branded him as an author the most despicable both in style and matter.' 'The censure (adds his lordship) is invidious and unjust. His work contains an immense multitude of interesting circumstances wholly omitted by the Scottish author. From his situation, a classical composition was not to be expected. He wrote a more complete general history of England than had ever appeared in this country; and, whatever be his faults, it would be ungenerous to deny his uncommon merit.' *Gard. Miscell.* p. 203.

**RAPINE**, *n. s.* Fr. *rapine*; Lat. *rapina*. The act of plundering: violence; force.

If the poverty of Scotland might, yet the plenty of England cannot, excuse the envy and rapine of the church's rights. *King Charles.*

The logic of a conquering sword may silence, but convince it cannot; its efficacy rather breeds aver-

VOL. XVIII.—PART 2.

sion and abhorrence of religion, whose first address is in blood and rapine.

*Decay of Piety.*

**RAPP** (John), a modern French general, was born of an obscure family at Colmar in 1772, and entered upon a military life in 1788. Having become a lieutenant, in the tenth regiment of chasseurs, he served as aid-de-camp to Dessaix in the campaigns of 1796 and 1797, and afterwards in Egypt. After the battle of Marengo he became aid-de-camp to Buonaparte; and in 1802 was employed in the subjugation of Switzerland. Returning to Paris the following year, he accompanied Buonaparte into Belgium: at the battle of Austerlitz he defeated the Russian imperial guard, and took prisoner prince Reppin. In December 1805 he was a general of a division; and appointed governor of Dantzic in 1807. After the campaign of 1812 he commanded the garrison of that city, which he defended with great skill and valor, but he was at length obliged to capitulate. In 1814 he submitted to the Bourbons; but joined Napoleon on his return; and after all his vicissitudes died in 1823 in favor with Louis XVIII., and a member of the chamber of Peers. *Mémoires du General Rapp* appeared at Paris the same year, 8vo.

**RAPPAHANNOCK**, a navigable river of Virginia, which rises in the Blue Ridge, and runs E. S. E. about 130 miles. It flows into the Chesapeake, twenty-five south of Potomac. It passes by the towns of Falmouth, Fredericksburgh, Port Royal, Leeds, Tappahannock, and Urbanna: has four fathoms water to Hobb's Hole, and is navigable for vessels of 130 or 140 tons to Fredericksburgh, 110 miles from its mouth.

**RAPPORT**, *n. s.* Fr. *rappat*, *rappart*. Relation; reference; proportion. A word introduced by Temple, but not copied.

'Tis obvious what *rappart* there is between the conceptions and languages in every country, and how great a difference this must make in the excellence of books.

*Temple.*

**RAPTURE**, *n. s.* } Lat. *rapio*. See RAP.  
**RAPTURED**, *adj.* } Violent seizure; ecstasy;  
**RAPTUROUS**. } transport; violence of passion; rapidity: raptured is ravished; transported: rapturous, ecstatic; transporting.

And thicke into our ship he threw his flash:  
 That 'gainst a rocke, or flat, her keele did dash  
 With headlong rapture. *Chapman.*

Could virtue be seen it would beget love, and advance it not only into admiration, but rapture.

*Holyday.*

The wat'ry throng,  
 Wave rolling after wave, where way they found,  
 If steep, with torrent rapture; if through plain  
 Soft-ebbing; nor withstood them rock or hill.

*Milton.*

Musick, when thus applied, raises in the mind of the hearer great conceptions; it strengthens devotion, and advances praise into rapture. *Addison.*

Are the pleasures of it so inviting and rapturous? is a man bound to look out sharp to plague himself?

*Coltier.*

Nor will he be able to forbear a rapturous acknowledgment of the infinite wisdom and contrivance of the divine artificer.

*Blackmore.*

You grew correct, that once with rapture writ.

*Pope.*

2 C

He drew  
Such maddening draughts of beauty to the soul,  
As for awhile o'erwhelmed his raptur'd thought  
With luxury too daring. *Thomson's Summer.*  
But can they melt the glowing heart,  
Or chain the soul in speechless pleasure,  
Or through each nerve the rapture dart,  
Like meeting her, our bosom's treasure?

*Burns.*

All love, half languor, and half fire,  
Like saints that at the stake expire,  
And lift their raptur'd looks on high,  
As though it were a joy to die. *Byron.*

RARE, *adj.* Fr. *rare*; Lat. *rarius*.  
RA'REE-SHOW, *n. s.* Uncommon; unfre-  
RARELY, *adv.* quent; scarce; excel-  
RARENESS, *n. s.* lent; incomparable;  
RARITY, thin; subtle: a rare-  
show is a rare show corruptly pronounced, and  
therefore written: rarely corresponds with rare;  
as well as rareness and rarity, which are synony-  
mes.

This jealousy  
Is for a precious creature; as she's *rare*,  
Must it be great; and as his person's mighty  
Must it be violent. *Shakspeare. Winter's Tale.*  
Live to be the show and gaze o' the time;  
We'll have thee, as our *rarer* monsters are,  
Painted upon a pole. *Shakspeare.*  
Haw *rarely* does it meet with this time's guise,  
When a man was willed to love his enemies. *Id.*  
Sorrow would be a *rarity* must be loved,  
If all could so become it. *Id. King Lear.*  
They are of so tender and weak a nature, as  
they affect only such a *rare* and attenuate substance,  
as the spirit of living creatures.

Tickling is most it, the soles, arm-holes, and sides:  
the cause is the thinness of the skin, joined with the  
*rareness* of being touched there; for tickling is a  
light motion of the spirits, which the thinness of the  
skin, the suddenness and rareness of touch, doth  
further. *Bacon.*

To worthiest things;  
Virtue, art, beauty, fortune, now I see  
*Rareness* or use, not nature, value brings.

*Donne.*

Bodies, under the same outward bulk, have a  
greater thinness and expansion, or thickness and so-  
lidity, which terms, in English, do not signify fully  
those differences of quantity; therefore I will do it  
under the names of *rarity* and density. *Digby.*

On which was wrought the gods and giants fight,  
*Rare* work, all filled with terror and delight.

*Cowley.*

For the *rareness*, and *rare* effect of that petition,  
I'll insert it as presented. *Clarendon.*

The cattle in the fields and meadows green,  
Those *rare* and solitary, these in flocks  
Pasturing at once, and in broad herds upspring.

*Milton.*

So eagerly the fiend  
O'er bog or steep, through strait, rough, dense, or  
*rare*,  
With head, hands, wings, or feet, pursues his way.

*Id.*

His temperance in sleep resembled that of his  
meals; midnight being the usual time of his going  
to rest, and four or five, and very *rarely* six, the hour  
of his rising. *Fill.*

Above the rest I judge one beauty *rare*.

*Dryden.*

Of my heart I now a present make;  
Accept it as when early fruit we send,  
And let the *rareness* the small gift commend. *Id.*

Far from being fond of any flower for its *rarity*, if  
I meet with any in a field which pleases me, I give  
it a place in my garden. *Spectator.*  
I saw three *rarities* of different kinds, which  
pleased me more than any other shows of the place.

*Addison.*

It would be a *rarity* worth the seeing, could any one  
show us such a thing as a perfectly reconciled enemy.

*South.*

The dense and bright light of the circle will ob-  
scure the *rare* and weak light of these dark colours  
round about it, and render them almost insensible.

*Newton's Opticks.*

Of *raree-shows* he sung, and Punch's feats.

*Gau.*

This I do, not to draw any argument against them  
from the universal rest or accurately equal diffusion  
of matter, but only that I may better demonstrate  
the great *rarity* and tenuity of their imaginary chaos

*Bentley's Sermons.*

The fashions of the town affect us just like a *raree-*  
*show*; we have the curiosity to peep at them, and  
nothing more. *Pope.*

Vanessa in her bloom,  
Advanced like Atalanta's star,  
But *rarely* seen, and seen from far. *Swift.*

I cannot talk with civet in the room,  
A fine puss gentleman that's all perfume;  
The sight's enough—no need to smell a beau—  
Who thrusts his nose into a *raree-show*? *Cowper*

RARE, *adj.* Sax. *þræne*; Goth. *rar*. Under-  
done by the fire.

New-laid eggs, with Baucis' busy care,  
Turned by a gentle fire, and roasted *rare*.

*Dryden*

RARE AND SCARCE BOOKS. We are not bib-  
liomaniacs. See the article LIBRARY: and in un-  
dertaking what we have there promised, to fir-  
nish the reader with a few criteria of rare and  
scarce, as distinguished from useful books, we  
shall not, of course, detain him long.

Of the date of MSS. we have already given  
the general marks in the article of that name:  
printed books are rare according to the date or  
circumstances of their being printed; the materi-  
al on which they are printed; the manner in  
which their circulation has been interrupted by  
authority or accident; whether they are on large  
or small paper; and the manner in which they  
have been illustrated. These have been called  
marks of *absolute* rarity.

Books are said to be *comparatively* or relatively  
rare which are of the first editions of particular  
places; which have proceeded from the press of  
certain distinguished printers of the last three  
centuries, as the Aldi, the Stephenses, Elzevirs,  
Brindley, Baskerville, &c.; which have never  
been offered to sale or have been sold under  
different titles; and lastly which are local, or  
confined to particular classes of mankind in  
their interest; such as the topography of certain  
places and districts, books treating of exploded  
arts or sciences, the history of particular academi-  
cists, catalogues of libraries, &c.

Some bibliographers have further distinguished  
books into those simply *rare*; books *precious*  
but not rare; and books *both* rare and precious.  
The first are such as from any circumstances are  
difficult to be procured; their value therefore is  
often wholly adventitious, and idle clergymen and  
noblemen are adding to this important list every

year by printing one or two copies of an impression of a book on vellum; illustrating it in some particular way, diversifying the binding, &c. Books *precious*, we are told, are those which have been of very great expense in bringing out: such as splendid collections of architectural engravings; large collections of uniform works on antiquities, &c., and why not Encyclopædias?

Books both rare and precious are those which extend to an immense number of volumes on an important subject, or are executed with remarkable care or splendor, and are therefore seldom found perfect, as the Collections of Travels published by De Bry, the *basis* of which alone cost Mr. Grenville £240, and a copy of which was lately purchased, as Dr. Dibdin tells us, by the duke of Devonshire for £546. 'Ah! it makes our heart rejoice,' says our author (and we unite in this feeling with him, only his fear is our hope), 'to think of the 'good old times,' the *golden* days of the bibliomania, when colonel Stanley's copy was sold; days I fear which are gone, never to return: Ramusio, de Bry, Hakluyt, and Purchas, Caxton, De Worde, Pynson, and William Faques, were then contemplated and caressed as their beauties and merits entitle them to be!'

We add, as calculated to exhibit the earlier difficulties and gradual improvements in the art of printing, the following directions for ascertaining editions of the fifteenth century. 1. The texture and thickness of the *paper* is to be regarded: as printed books were at first imitations of MSS., they were made to imitate vellum as nearly as possible. 2. The unequal size and general clumsiness of the *type*. It was, however, soon improved in these respects. 3. The *absence* of title pages; printer's name and abode; date when printed; signatures or letters marking the sheet; and catchwords on the right hand page. Title-pages first began to be printed separately about 1470, some say 1480, but were very rare until the beginning of the sixteenth century. 4. The infrequency of *divisions*, and of capital letters at the beginning of divisions, chapters, &c. The plan was at first to leave these to be filled up by illuminators who ornamented them with the gold and fine colors that enrapture our bibliomaniacs. 5. The little *punctuation* that appears, and particularly the omission of commas and semi-colons. Books printed about the middle of the fifteenth century have no stops but periods. 8. The numerous *abbreviations*, as *neqz*, *quibz*, for neque and quibus; *Dns* for Dominus and many others less intelligible. See Jungendre. *Disertatio de Notis Characterist. Librorum à Typograph. Incurabulo ad Ann. M. D. impressorum*, Norimb. 1740. Dibdin's *Bibliomania*, Horne's *Introduction to Bibliography*, &c.

Finally, the reader may contrast the scarceness of books in the dark ages with their present abundance. 'Many circumstances,' says Dr. Robertson (Charles V. vol. i.) 'prove the scarcity of books during these ages. Private persons seldom possessed any books whatever. Even monasteries of considerable note had only one missal. Murat. Antiq. vol. ix. p. 739. Lupus, abbot of Ferrieres, in a letter to the pope, A. D.

855, beseeches him to lend him a copy of Cicero de Oratore, and Quintilian's Institutions; 'for,' says he, 'although we have parts of those books, there is no complete copy of them in all France.' Murat. Ant. v. iii. p. 835. The price of books became so high that persons of a moderate fortune could not afford to purchase them. The countess of Anjou paid for a copy of the Homilies of Haimon, bishop of Halberstadt, 200 sheep, five quarters of wheat, and the same quantity of rye and millet. Histoire Literaire de France, par des Religieux Benedictins, tom. vii. p. 3. Even so late as the year 1471, when Louis XI. borrowed the works of Rasis, the Arabian physician, from the faculty of medicine in Paris, he not only deposited in pledge a considerable quantity of plate, but was obliged to procure a nobleman to join with him as surety in a deed, binding himself, under a great forfeiture, to restore it. Gabr. Naudé Addit. à l'Histoire de Loyus XI. par Comines, edit. de Fresnoy, tom. iv. p. 281. Many curious circumstances, with respect to the extravagant price of books in the middle ages, are collected by that industrious compiler, to whom I refer such of my readers as deem this small branch of literary history an object of curiosity. When any person made a present of a book to a church or a monastery, in which were the only libraries during several ages, it was deemed a donative of such value that he offered it on the altar, pro remedio animæ suæ, in order to obtain the forgiveness of his sins. Murat. vol. iii. p. 836. Hist. Liter. de France, tom. vi. p. 6. Nouv. Trait. du Diplomate par deux Benedictins, 4to. tom. i. p. 481.' In these 'good old times,' to adopt Dr. Dibdin's phrase, we suppose the editor of an Encyclopædia would have been at least a cardinal!

RAREFY, *v. a. & n.* } Fr. *rarefier*; Lat. *rarus*  
 RAREFACTION. } and *factio*. To make thin  
 or subtle; become thin or rare; act of doing  
 this or becoming so: extension of the parts of a  
 body.

The water within being *rarefied*, and by *rarefaction* resolved into wind, will force up the smoke.

Wotton's Architecture

Earth *rarefies* to dew; expanded more  
 The subtle dew in air begins to soar.

Dryden.

When exhalations, shut up in the caverns of the earth by *rarefaction* or compression, come to be straitened, they strive every way to set themselves at liberty. Burnet.

To the hot equator crowding fast,  
 Where highly *rarefied* the yielding air  
 Admits their steam.

Thomson.

RARITAN, a river of New Jersey, formed by two branches, which unite about twenty miles above New Brunswick. It becomes navigable two miles above that city, at a place called Brunswick Landing. Flowing by New Brunswick and gradually becoming broader and deeper, it passes Amboy, and then widens into Raritan Bay, which is immediately connected with the ocean. It is navigable for sloops of eighty tons, as far as New Brunswick, seventeen miles. The general course of the Raritan is south of east. It is inclosed to connect this

river with the Delaware, by a canal which is to commence between New Brunswick and Washington, and join the Delaware at Crosswick's Creek. The distance is twenty-nine miles.

**RAS EL KHY MA**, the chief town of the Pirates on the Persian Gulf. There is a suburb of bamboo huts. Here are several castles, one the residence of the chief, and another for naval stores. In 1809 the depredations of the pirates induced the British authorities to fit out an expedition against them. On the 13th of November Ras el Khyma was taken by storm, the ships burned, and the guns spiked: the British loss consisted of only one killed, and four wounded. In the course, however, of a few years, the enemy had repaired the place and its defences, and had again become so formidable that a new expedition was sent against them, which effected its object with the same success. Long. 55° 30' E., lat. 25° 49' N.

**RASCAL**, *n. s.* } Sax. *parcal*. 'A lean  
**RASCALION**, } beast,' says Johnson: pro-  
**RASCALITY**, } perly a lean deer. See the  
**RASCALLY**, *adj.* } fine instance of its use so  
late as in Shakspeare, and the equivoque of Falstaff which can only be thus understood. A mean fellow; a scoundrel: rascalion is synonymous: rascality and rascally correspond.

For the *rascal* commons, lest he cared. *Spenser*.  
And when him list the *rascal* routs appal,  
Men into stones therewith he could transwear. *Id.*  
A little herd of England's humorous deer,  
Mazed with the yelping kennels of French curs!  
If we be English deer be then in blood,  
Not *rascal*-like, to fall down with a pinch;  
But rather moody-mad and desperate stags,  
Turn on the bloody hounds with heads of steel,  
And make the cowards aloof at bay.

*Shakspeare. Henry VI.*  
The *rascal* people, thirsting after prey,  
Join with the traitor. *Id.*  
DOL.—You muddy *rascal* is that all the comfort  
you give me?  
FAL.—You make fat *rascals* mistress Doll.

*Id. Henry IV.*  
Would'st thou not be glad to have the niggardly  
*rascally* sheep biter come by some notable shame?  
*Shakspeare.*

That proud dame  
Used him so like a base *rascalion*,  
That old Pig—what d' ye call him—malice,  
That cut his mistress out of stone,  
Had not so hard a hearted one. *Hudibras.*  
Pretended philosophers judge as ignorantly in their  
way, as the *rascality* in theirs. *Glanville.*  
Did I not see you, *rascal*, did I not,  
When you lay snug to snap young Damon's goat?  
*Dryden.*

I have sense, to serve my turn, in store,  
And he's a *rascal* who pretends to more. *Id.*  
Scoundrels are insolent to their superiors; but it  
does not become a man of honour to contest with  
mean *rascals*. *L'Estrange.*

Jeroboam having procured his people gods, the next  
thing was to provide priests; hereupon, to the  
calves he adds a commission, for the approving, try-  
ing, and admitting the *rascality* and lowest of the  
people to minister in that service. *South.*

The poor girl provoked told him he lyed like a  
*rascal*. *Swift.*

Our *rascally* porter is fallen fast asleep with the  
black cloth and sconces, or we might have been  
tacking up by this time. *Id.*

**RASCIANS**, or **RAITZEN**, a numerous and an-  
cient Slavonic tribe, inhabiting the south of  
Hungary. They are supposed to be the de-  
scendants of Christians who fled from the district  
of Rascia, in Servia and Bosnia, when they were  
invaded by the Turks. They came into Hungary  
early in the fifteenth century, and received parti-  
cular privileges. Some time after their arrival  
they were driven by the Turks farther north.  
They are found at present in considerable num-  
bers in the Bannat, in Sclavonia, and other parts  
of the south of Hungary. In Croatia they form  
a third of the population. They live in great  
simplicity, partly employed in agricultural and  
pastoral occupations, and partly in woollen and  
linen manufactures. Early marriage is customary  
among them, and their increase consequently con-  
siderable; but they have never exhibited, during  
three centuries, Mr. Malthus's fearful propensity  
to multiply. The Uscocks and Morlachians ap-  
pear to be of the same descent, but are behind  
the Rascians in civilisation. Each of these tribes  
calls itself by the name of Srbi, or Servians, and  
all speak dialects of the Illyrian language.

**RASE**, *v. a.* } Fr. *raser*, of Lat. *rasus*. 'I  
**RASURE**, *n. s.* } would write rase,' says John-  
son, 'when it signifies to strike slightly, per-  
stringere; and raze, when it signifies to ruin,  
deleere.' To skim; strike on the surface; blot  
out; overthrow: rasure is the mark made by  
blotting or rubbing out.

He certifies your lordship that this night  
He dreamt the boar had *razed* off his helm.

*Shakspeare*  
Though of their names in heav'nly records now  
Be no memorial, blotted out and *razed*. *Milton.*  
Was he not in the nearest neighbourhood to  
death? and might not the bullet, that *razed* his  
cheek, have gone into his head? *South.*  
Such a writing ought to be free from any vituperation  
of *rasure*. *Ayliffe's Parergon.*

**RASH**, *adj.* } Belg. and Teut. *rasch*;  
**RASHLY**, *adv.* } Swed. and Dan. *rask*.  
**RASHNESS**, *n. s.* } Hasty; violent; precipi-  
tate: the adverb and noun substantive corres-  
ponding.

Be not *rash* with thy mouth, and let not thine  
heart be hasty to utter any thing before God: for  
God is in heaven, and thou upon earth; therefore  
let thy words be few. *Eccles.*

This is to be bold without shame, *rash* without  
skill, full of words without wit. *Ascham.*

Who seeth not what sentence it shall enforce us  
to give against all chutches in the world: inasmuch  
as there is not one, but hath had many things estab-  
lished in it, which though the scripture did never  
command, yet for us to condemn were *rashness*.

*Hooder.*  
Blast her pride, O ye blest gods! so will you  
wish on me, when the *rash* mood is on me.

*Shakspeare. 1*  
This expedition was by York and Talbot  
Too *rashly* plotted. *Id. Henry VI.*  
Men are not *rashly* to take that for done which is  
not done. *Bacon.*

Nature to youth hot *rashness* doth dispense,  
But with cold prudence age doth recompence.  
*Denham.*

Her *rash* hand in evil hour,  
Forth reaching to the fruit, she plucked, she eat.  
*Milton.*

The vain Morat by his own rashness wrought,  
Too soon discovered his ambitious thought,  
Believed me his, because I spoke him fair. *Dryden.*  
He that doth any thing rashly, must do it will-  
ingly; for he was free to deliberate or not.

*L'Estrange.*

Declare the secret villain,

The wretch so meanly base to injure Phædra,  
So rashly brave to dare the sword of Theseus.

*Smith.*

In so speaking, we offend indeed against truth;  
yet we offend not properly by falsehood, which is a  
speaking against our thoughts; but by rashness,  
which is an affirming or denying, before we have suf-  
ficiently informed ourselves.

*South.*

RASH'ER, *n. s.* Lat. *rasura*. A thin slice of  
bacon.

If we grow all to be pork eaters, we shall not  
shortly have a *rasher* on the coals for money.

*Shakspeare. Merchant of Venice.*

White and black was all her homely cheer,  
And *rashers* of singed bacon on the coals.

*Dryden.*

Quenches his thirst with ale in nut-brown bowls,  
And takes the hasty *rasher* from the coals. *King.*

RASP, *v. a. & n. s.* } Fr. *rasper*; Ital. *raspare*;  
RASP'ATORY, *n. s.* } Span. *raspar*. To rub to  
powder with a rough file; the file used: a sur-  
geon's rasp.

Having prepared hard woods and ivory for the  
lathe with *rasping*, they pitch it between the pikes.

*Moxon.*

Case-hardening is used by file-cutters, when they  
make coarse files, and generally most *rasps* have  
formerly been made of iron and case-hardened.

*Moxon's Mechanical Exercises.*

Some authors have advised the *rasping* of these  
bones; but in this case it is needless.

*Wiseman.*

I put into his mouth a *raspatory*, and pulled away  
the corrupt flesh, and with cauteries burnt it to a  
crust.

*Id. Surgery.*

RASP, *n. s.* } Ital. *raspo*. A delicious berry  
RASP'BERRY. } that grows on a species of the  
bramble; a raspberr.

Set sorrel amongst *rasps*, and the *rasps* will be the  
smaller.

*Bacon.*

Raspberries are of three sorts; the common wild  
one, the large red garden raspberr, which is one of  
the pleasantest fruits, and the white, which is little  
inferior to the red.

*Mortimer's Husbandry.*

Now will the corinths, now the *rasps* supply  
Delicious draughts, when prest to vines. *Philips.*

RASPBERRY-TREE. See RUBUS.

RASTADT, a town of Baden, the capital of  
the district of Murg, and the seat of one of the  
four grand courts of the duchy. Here is an ex-  
cellent manufacture of fire arms; but the town  
is chiefly noted as having been, in 1714 and  
1798, the seat of diplomatic conferences. On  
this last occasion two of the French negociators,  
on their journey to Strasburg, were assassinated  
in a manner never fully explained, but supposed  
to have been the act of common robbers. In  
the campaign of 1796 the French obtained here  
an advantage over the Austrians. Twenty miles  
N. N. E. of Strasburg.

RASTALL (John), a printer and miscellaneous  
writer, born in London about the end of the  
fifteenth century, and educated at Oxford. He  
married the sister of Sir Thomas More, with  
whom he was very intimate, and whose writings

he strenuously defended. He died in 1536.  
Rastall was a zealous Papist. He wrote, 1. Na-  
tura Naturata. Pits calls it an ingenious comedy  
describing Europe, Asia, and Africa, with cuts  
2. The Pastyme of the People; the Cronycles  
of diverse Realmys, and most especially of the  
realm of England, fol. 3. Ecclesia Johannis  
Rastal, 1542; one of the prohibited books in the  
reign of Henry VIII. 4. Logum Anglicanarum  
vocabula explicata. French and Latin. Lon-  
don 1567, 8vo.

RAT, *n. s.* Sax. *ræt*; Fr. *rat*; Belg. *ratte*;  
Swed. and Span. *ratta*; *raton*. An animal of the  
mouse kind that infests houses and ships: to  
'smell a rat' is to suspect; be on the watch.

Our natures do pursue

Like *rats* that ravin down their proper banco.

*Shakspeare.*

I have seen the time, with my long sword I would  
have made you four tall fellows skip like *rats*. *Id.*

Quoth Hudibras, I smell a *rat*,

Ralpo, thou dost prevaricate. *Hudibras.*

Thus horses will knable at walls, and *rats* will  
gnaw iron. *Brown's Vulgar Errors.*

If in despair he goes out of the way like a *rat* with  
a dose of arsenick, why he dies nobly. *Dennis.*

RAT, in zoology. See MUS.

RATAFIA is prepared from the kernels, &c.  
of several other kinds of fruits. Ratafia of  
cherries is prepared by bruising the cherries, and  
putting them into a vessel, wherein brandy has  
been long kept; then adding to them the kernels  
of cherries with strawberries, sugar, cinnamon,  
white pepper, nutmeg, cloves; and to 20 lbs.  
of cherries ten quarts of brandy. The vessel is  
left open ten or twelve days, and then stopped  
close for two months before it is tapped. Ratafia  
of apricots is prepared two ways, viz. either by  
boiling the apricots in white wine, adding to the  
liquor an equal brandy, with sugar, cinnamon,  
mace, and the kernels of apricots; infusing the  
whole for eight or ten days; then straining the  
liquor, and putting it up for use: or else by in-  
fusing the apricots, cut in pieces, for a day or  
two, passing it through a straining bag, and then  
putting in the usual ingredients.

RATAN (*calamus*); a genus of palms, but  
widely differing in habit from the rest of that  
family, and, in this respect, somewhat re-  
sembling the grasses. The species have all pe-  
rennial, long, round, solid, jointed, unbranching  
stems, extremely tough and pliable, often as-  
cending among the branches of trees, but with-  
out prickles or tendrils. They grow in profu-  
sion along the banks of rivers in tropical Asia  
and the neighbouring islands. All the species  
are very useful, and are applied to various pur-  
poses: the fruit and young stems of all furnish  
nourishment, and a drink is obtained from the li-  
quid which flows from wounds made in the  
spadix. One species is even cultivated for its  
fruit, which is about the size of a walnut, and  
covered with scales. Certain species furnish  
cables, cords, and withes of exceeding strength;  
others are split into strips for making the seats  
and backs of chairs, baskets, and other light and  
elegant articles of furniture; those which are  
larger and firmer, and whose joints are more  
distant, afford elegant walking-sticks; in short,

the economical purposes to which the various species of ratans are applied, are very numerous, even in northern climates. A trade in ratans, to considerable extent, is carried on from several of the East India islands to China, which is the principal market for them.

RATE, *n. s.*, *v. a.* & *v. n.* } Old Fr. *rate*; Lat. *RATABLE*, *adj.* } *ratus*. Price fixed or allowance settled; tax; degree; value; principle of value; quantity; manner: to value at a price; make an estimate.

I am a spirit of no common *rate*;  
The summer still doth tend upon my state.

*Shakespeare.*

The Danes brought in a reckoning of money by *ores*, per *ore*; I collect out of the abbey-book of Burton, that twenty *ore* were *ratable* to two marks of silver.

*Camden's Remains.*

To which relation whatsoever is done agreeably, is morally and essentially good; and whatsoever is done otherwise is at the same *rate* morally evil.

*South.*

You seem not high enough your joys to *rate*,  
You stand indebted a vast sum to fate,  
And should large thanks for the great blessings pay.

*Dryden.*

RATE, *v. a.* Isl. and Goth. *reita*. To chide hastily and vehemently.

Go *rate* thy minions, proud insulting boy;  
Becomes it thee to be thus bold in terms  
Before thy sovereign?

*Shakespeare. Henry VI.*

RATE, the name of the classes into which ships of war are divided in the navy, according to their force and magnitude; thus the *first rate* comprehends all ships of 100 guns and upwards; *second rate* includes all ships carrying from 90 to 98 guns, upon three decks; *third rate* consists of ships from 64 to 80 cannon; *fourth rates* consist of ships from 50 to 60 guns, upon two decks and the quarter-deck. All vessels of war under the fourth *rate* are usually comprehended under the general names of *frigates*, and never appear in the line of battle. They are divided into two rates, viz. *fifth rates*, mounting from 32 to 40 or 44 guns; and *sixth rates*, of from 20 to 30 guns.

RATH, *n. s.* Goth. and Swed. *rad*. A hill. Out of use.

There is a great use among the Irish, to make great assemblies upon a *rath* or hill, there to parly about matters and wrongs between townships or private persons.

*Spenser.*

RATH, *adj.* } Sax. *rað*, soon. Early; be-  
RATHER, *adv.* } fore the usual time: rather, the comparative of Sax. *rað*, meaning sooner, is more willingly; with better liking.

This is he that I seide of, after me is comun a man, which was made before me, for he was *rather* than I.

*Wiclif. Jon i.*

Almighty God desireth not the death of a sinner, but *rather* that he should turn from his wickedness and live.

*Common Prayer.*

Thus is my summer worn away and wasted,  
Thus is my harvest hastened all to *ratha*,  
The ear, that budded fair, is burnt and blasted,  
And all my hoped gain is turned to scathe.

*Spenser.*

This is an art,  
Which does mend nature, change it *rather*, but  
The art itself is nature.

*Shakespeare. Winter's Tale*

You are come to me in a happy time,  
The *rather* for I have some sport in hand.

*Shakespeare.*

*Rath* ripe are some, and some of later kind,  
Of golden some, and some of purple rind. *May.*  
Bring the *rath* primrose that forsaken dies,  
The tufted crow-toe and pale jessamine. *Milton.*  
He sought through the world, but sought in vain.  
And, no where finding, *rather* feared her slain.

*Dryden.*

'Tis *rather* to be thought that an heir had no such right by divine institution, than that God should give such right, but yet leave it undetermined who such heir is.

*Loche.*

'Tis with reluctance he is provoked by our impetuosity to apply the discipline of severity; he had *rather* mankind should adore him as their patron and benefactor.

*Rogers.*

RATIFY, *v. a.* } Lat. *ratum facio*. To con-  
RATIFIER, *n. s.* } firm; settle: he who settles  
RATIFICATION. } or confirms: confirmation.

We have *ratified* unto them the borders of Judæa.

*I Mac.*

There must be zeal and fervency in him which proposeth for the rest those suits and supplications, which they by their joyful acclamations must *ratify*.

*Hooker.*

They cry, 'chuse we Laertes for our king:'  
The *ratifiers* and props of every word,  
Caps, hands, and tongues applaud it to the clouds.

*Shakespeare.*

By the help of these, with him above  
To *ratify* the work, we may again  
Give to our tables meat, sleep to our nights. *Id.*

Tell me, my friend, from whence hadst thou the skill,

So nicely to distinguish good from ill?  
And what thou art to follow, what to fly,  
This to condemn, and that to *ratify*?

*Dryden.*

God *ratified* their prayers by the judgment brought down upon the head of him whom they prayed against.

*South.*

RATIO, *n. s.* Lat. *ratio*. Proportion.

Whatever inclination the rays have to the plane of incidence, the sine of the angle of incidence of every ray, considered apart, shall have to the sine of the angle of refraction a constant *ratio*.

*Cheyne.*

RATIO, in arithmetic and geometry, is that relation of homogeneous things which determines the quantity of one from the quantity of another, without the intervention of a third. Two numbers, lines, or quantities, A and B, being proposed, their relation one to another may be considered under one of these two heads:—1. How much A exceeds B, or B exceeds A? And this is found by taking A from B, or B from A, and is called arithmetic *ratio*. 2. Or how many times, and parts of a time, A contains B, or B contains A? And this is called geometric reason or *ratio* (or, as Euclid defines it, it is the mutual habitude or aspect of two magnitudes of the same kind, according to quantity; that is, as to how often the one contains, or is contained in, the other), and is found by dividing A by B, or B by A. And here note, that that quantity which is referred to another quantity is called the antecedent of the *ratio*; and that to which the other is referred is called the consequent of the *ratio*; as, in the *ratio* of A to B, A is the antecedent, and B the consequent. Therefore any quantity, as antecedent, divided by any quantity is a consequent, gives the

ratio of that antecedent to the consequent. Thus the ratio of A to B is  $\frac{A}{B}$ , but the ratio of B to A is  $\frac{B}{A}$ ; and in numbers, the ratio of 12 to 4 is  $\frac{12}{4} = 3$ , or triple; but the ratio of 4 to 12 is  $\frac{4}{12} = \frac{1}{3}$ , or subtriple. And here note, that the quantities thus compared must be of the same kind; that is, such as by multiplication may be made to exceed one the other, or as these quantities are said to have a ratio between them, which, being multiplied, may be made to exceed one another. Thus a line, how short soever, may be multiplied, that is, produced so long as to exceed any given right line; and consequently these may be compared together, and the ratio expressed; but as a line can never, by any multiplication whatever, be made to have breadth, that is, to be made equal to a superficies, how small soever; these can therefore never be compared together, and consequently have no ratio or respect one to another.

**RATION**, in the army, a portion of ammunition, bread, drink, and forage, distributed to each soldier in the army, for his daily subsistence, &c. The horse have rations of hay and oats when they cannot go out to forage. The rations of bread are regulated by weight. The ordinary ration of a foot soldier is a pound and a half of bread per day. The officers have several rations, according to their quality, and the number of attendants they are obliged to keep. When the ration is augmented on occasions of rejoicing, it is called a double ration. The ships' crews have also their rations, or allowances of biscuit and water, proportioned according to their stock.

**RATIONAL**, *adj.* Latin *rationalis*.  
**RATIOCINATE**, *v. n.* Having reason; agree-  
**RATIOCINATION**, *n. s.* able to reason; wise: to  
**RATIOCINATIVE**, *adj.* ratiocinate (not used)  
**RATIONALIST**, *n. s.* means, to reason or  
**RATIONALITY**, argue, ratiocination  
**RATIONALLY**, *adv.* corresponding: ratiocinative is argumentative: rationalist is, one who reasons or proceeds upon reason: rationality, power of reason; or reasonableness: rationally follows the senses of rational.

He often used this comparison: the empirical philosophers are like to pismires; they only lay up and use their store: the *rationalists* are like to spiders; they spin all out of their own bowels: but give me a philosopher, who, like the bee, hath a middle faculty, gathering from abroad, but digesting that which is gathered by his own virtue. *Bacon.*

God decreed to create man after his own image, a free and *rational* agent. *Hammond.*

The discerning of that connexion or dependence which there is betwixt several propositions, whereby we are enabled to infer one proposition from another, which is called *ratiocination* or discourse. *Wilkins.*

What higher in her society thou findest  
 Attractive, humane, rational, love still. *Milton.*

Some consecutions are so intimately and evidently connected to, or found in the premises, that the conclusion is attained quasi per saltum, and without any thing of *ratiocinative* process, even as the eye sees his object immediately, and without any previous discourse. *Hale's Origin of Mankind.*

When the conclusion is deduced from the unerring

dictates of our faculties, we say the inference is *rational*. *Glauville's Sceptis.*

In human occurrences, there have been many well directed intentions, whose *rationalities* will never bear a rigid examination. *Broune's Vulgar Errors.*

Can any kind of *ratiocination* allow Christ all the marks of the Messiah, and yet deny him to be the Messiah? *South.*

Upon the proposal of an agreeable object, it may *rationally* be conjectured, that a man's choice will rather incline him to accept than to refuse it. *South.*

When God has made *rationality* the common portion of mankind, how came it to be thy enclosure? *Government of the Tongue.*

Such an inscription would be self-evident without any *ratiocination* or study, and could not fail constantly to exert its energy in their minds. *Bentley.*

If your arguments be *rational*, offer them in as moving a manner as the nature of the subject will admit; but beware of letting the pathetic part swallow up the *rational*. *Swift.*

If it be our glory and happiness to have a *rational* nature, that is endowed with wisdom and reason, that is capable of imitating the divine nature; then it must be our glory and happiness to improve our reason and wisdom, to act up to the excellency of our *rational* nature, and to imitate God in all our actions, to the utmost of our power. *Laws.*

**RATS'BANE**, *n. s.* Rat and bane. Poison for rats; arsenic.

When murder's out, what vice can we advance,  
 Unless the new-found pois'ning trick of France!  
 And when their art of *ratsbane* we have got,  
 By way of thanks, we'll send 'em o'er our plot. *Dryden.*

He would throw *ratsbane* up and down a house,  
 where children might come at it. *L'Etrange.*

I can hardly believe the relation of his being poisoned, but sack might do it, though *ratsbane* would not. *Swift to Pope.*

**RATISBON**, German Regensburg, an ancient city of Bavaria, long known as the place of meeting for the imperial diet. It is situated on the south bank of the Danube, opposite to the influx of the river Regen, from which its German name is derived, and is surrounded with an earthen mound, though not defensible against an army. It is built of stone, but the houses are very high and old; the streets narrow and crooked. The town-house partakes of the gloomy character of the rest of the town, and the apartment where the diet held its sittings is plain even to meanness. But the cathedral and the church of St. Emeran, the former a venerable Gothic pile and the latter containing a number of good paintings, are worth attention; and after these the episcopal residence, a palace belonging to the prince of Tour and Taxis; the Jesuits' college; the arsenal, and the Haidplatz, where tournaments were formerly given. Here is also a public drawing-school, two public libraries, and several hospitals.

When Ratisbon had the exclusive navigation of the Danube to Vienna, and upwards to Ulm, it was of course far more brisk as a trading town; but it possesses still a considerable share of traffic in timber, corn, and salt. The town has extensive dock-yards for the building of boats and lighters, and a number of breweries and distilleries, but few manufactures. It has long been a favorite residence of the respectable classes of so-



ciety; and formerly the presence of the diet, which assembled here habitually, from 1662, until the extinction of the body in 1805, contributed much to its support. The majority of the inhabitants are Catholics; and Ratisbon (reduced in 1817 to a bishopric) was long the see of an archbishop, who had a considerable territory, and was at the head of the abbey of St. Emeran, situated within the walls, and a small town of itself. In the river is an island, crossed by a bridge of great length, extending across the Danube, and connecting the city with its northern suburb, Stadtham Hof. In April 1809, this country was the scene of obstinate contests between the French and Austrians. Ratisbon is sixty-three miles N. N. E. of Munich, and 127 south-west of Prague. Population 20,000.

**RATTEEN**, *n. s.* Fr. *ratine*; Span. *ratina*. A kind of stuff.

We'll rig in Meath-street Egypt's haughty queen,  
And Antony shall court her in *ratteen*. *Swift*.

**RATTLE**, *v. n., v. a. & n. s.* } Belg. *rutelen*;  
**RATTLE-SNAKE**, *n. s.* } or a frequentative  
of Sax. *neotan*. To make a sharp, quick, or clattering noise; speak clamorously or eagerly; to move any thing so as to make a clatter; to stun or drive with noise; scold: the noise made; loud and empty talk; a child's toy: the rattlesnake is the genus *crotalus* of amphibia, serpents. See **CROTALUS**.

The quiver *rattlETH* against him. *Job xxxix. 23.*  
The noise of a whip, of the *rattling* of the wheels,  
of prancing horses, and of the jumping chariots.

*Nahum iii. 2.*  
Sound but another, and another shall,  
As loud as thine, *rattle* the welkin's ear,  
And mock the deep-mouthed thunder.

*Shakspeare.*  
The *rattles* of Isis, and the cymbals of Brasilea,  
nearly enough resemble each other. *Raleigh.*  
He should be well enough able to scatter the Irish  
as a flight of birds, and *rattle* away this swarm of  
bees with their king. *Bacon.*

They had, to affright the enemies horses, big *rattles*  
covered with parchment, and small stones within;  
but the *rattling* of shot might have done better service.

All this ado about the golden age is but an empty  
*rattle* and frivolous conceit. *Hobbes.*  
Opinions are the *rattles* of immature intellects, but  
the advanced reasons have outgrown them.

*Glanville's Scep sis.*  
She loses her being at the very sight of him, and  
drops plump into his arms, like a charmed bird into  
the mouth of a *rattlemake*. *More's Foundling.*

With jealous eyes at distance she hath seen  
Whispering with Jove the silver-footed queen;  
Then, impotent of tongue, her silence broke,  
Thus turbulent in *rattling* tone she spoke. *Dryden.*

Her chains she *rattles*, and her whip she shakes.  
*Id.*

They want no *rattles* for their froward mood,  
Nor nurse to reconcile them to their food. *Id.*

Hearing *Æsop* had been beforehand, he sent for  
him in a rage, and *rattled* him with a thousand traitors  
and villains for robbing his house. *L'Étrange.*  
The *rattlemake* is so called from the *rattle* at the  
end of his tail. *Grew's Museum.*

There she assembles all her blackest storms,  
And the rude hail in *rattling* tempest forms.  
*Addison.*

I'll hold ten pound my dream is out;  
I'd tell it you but for the *rattle*  
Of those confounded drums. *Pope*  
She that would sometimes *rattle* off her servants  
sharply, now, if she saw them drunk, never took  
notice. *Arbushnot.*

Farewel then, verse, and love, and every toy,  
The rhymes and *rattles* of the man or boy;  
What right, what true, what fit we justly call,  
Let this be all my care, for this is all. *Pope.*

He is a man of pleasure, and a free-thinker; he is  
an assessor of liberty and property; he *rattles* it out  
against popery. *Swift.*

**RATTLE-SNAKE.** See **CROTALUS**.

**RAVAGE**, *v. a. & n. s.* } Fr. *ravager*; barb.  
**RAVAGER**, *n. s.* } Lat. *brassiare*. To lay  
waste; ransack; pillage: the spoil or ruin thus  
made: ravager, he who makes it.

Some cruel pleasure will from thence arise,  
To view the mighty *ravage* of your eyes.

*Dryden.*  
Would one think 'twere possible for love  
To make such *ravage* in a noble soul? *Addison.*  
Those savages were not then what civilized man-  
kind is now; but without mutual society, without  
arms of offence, without houses or fortifications, an  
obvious and exposed prey to the *ravage* of devouring  
beasts. *Bentley.*

When that mighty empire was overthrown by the  
northern people, vast sums of money were buried to  
escape the plundering of the conquerors; and what  
remained was carried off by those *ravagers*. *Swift.*

His blasts obey, and quit the howling hill,  
The shattered forest, and the *ravaged* vale.

*Thomson.*  
Cambyses marched one army from Thebes, after  
having overturned the temples, *ravaged* the country,  
and deluged it with blood, to subdue Ethiopia: this  
army almost perished by famine, insomuch that they  
repeatedly slew every tenth man to supply the re-  
mainder with food. *Darwin.*

**RAUCITY**, *n. s.* Lat. *raucus*. Hoarseness;  
loud rough noise.

Inequality not stayed upon, but passing, is rather  
an increase of sweetness; as in the purling of a  
wreathed string, and in the *raucity* of a trumpet.

*Bacon's Natural History.*

**RAVE**, *v. n.* } Fr. *rêver*; Belg. *reux*;  
**RAVINGLY**, *adv.* } Lat. *rabo*. To be delirious;  
talk irrationally or incoherently; burst into furious  
exclamations.

Shall these wild distempers of thy mind,  
This tempest of thy tongue, thus *rave*, and find  
No opposition? *Sandy's Paraphrase on Job.*  
In this depth of muses, and divers sorts of dis-  
courses, would she *ravingly* have remained. *Sidney.*  
Our *ravings* and complaints are but like arrows  
shot up into the air, at no mark, and so to no purpose.  
*Temple.*

Another partiality is as fantastical and wild, at-  
tributing all knowledge to the ancients or the  
moderns; this *raving* upon antiquity, in matter of  
poetry, Horace has wittily exposed in one of his  
satires. *Locke.*

Her grief has wrought her into frenzy!  
The images her troubled fancy forms  
Are incoherent, wild; her words disjointed:  
Sometimes she *raves* for musick, light, and air;  
Nor air, nor light, nor musick calm her pains.  
*Smith.*

He swore he could not leave me,  
With ten thousand *ravings*.  
*Keac's Royal Court*

Wonder at my patience,  
Have I not cause to *rave*, and beat my breast,  
To rend my heart with grief, and run distracted ?

*Addison.*

Men who thus *rave*, we may conclude their brains  
are turned, and one may as well read lectures at  
Bedlam as treat with such.

*Government of the Tongue.*

It soon infecteth the whole member, and is ac-  
companied with watching and *raving*. *Wiseman.*

Revenge, revenge, thus *raving* through the streets,  
I'll cry for vengeance. *Southern's Spartan Dams.*

RAV'EL, *v. a. & v. n.* Belg. *ravelen*. To  
entangle; perplex; involve; entwine one with  
another; unweave; undo knit-work; to fall into  
perplexity or confusion; work in a perplexed  
state.

Sleep, that knits up the *raveled* sleeve of care.

*Shakspeare.*

As you unwind her love from him,  
lest it should *ravel*, and be good to none,

You must provide to bottom it on me. *Id.*

It will be needless to *ravel* far into the records of  
elder times; every man's memory will suggest many  
pertinent instances. *Decay of Piety.*

They but *ravel* it over loosely, and pitch upon  
disputing against particular conclusions, that, at the  
first encounter of them single, seem harsh to them.

*Digby.*

Give the reins to wandering thought,  
Regardless of his glory's diminution;  
Fill, by their own perplexities involved,  
They *ravel* more, still less resolved,  
But never find self-satisfying solution.

*Milton.*

If then such praise the Macedonian got,  
For having rudely cut the Gordian knot;  
What glory's due to him that could divide  
Such *raveled* interests, has the knot untied,  
And without stroke so smooth a passage made,  
Where craft and malice such obstructions laid!

*Waller.*

The humour of *ravelling* into all these mystical or  
intangled matters, mingling with the interest and  
passions of princes and of parties, and thereby  
heightened and inflamed, produced infinite disputes.

*Temple.*

RAVELIN, in fortification, was anciently a flat  
bastion placed in the middle of a curtain. See  
FORTIFICATION.

RA'VEN, *n. s., v. a. & v. n.* Saxon *ƿræfn*,

RA'VEOUS, *adj.* } *ƿræfian*, to rob;

RA'VEOUSLY, *adv.* } Belg. *raven*; Goth.

RA'VEOUSNESS, *n. s.* } and Swed. *rufn*.

A large black carnivorous fowl, whose cry is  
supposed ominous: to prey rapaciously: the ad-  
jective, &c., corresponding.

Benjamin shall *raven* as a wolf; in the morning he  
shall devour the prey, and at night he shall divide  
the spoil. *Genesis.*

They gaped upon me with their mouths, as a  
*ravening* and a roaring lion. *Psalms xxii. 13.*

The lion strangled for his lionesses, and filled his  
holes with prey, and his dens with *ravin*. *Nahum.*

The *raven* himself is hoarse

That crotches the fatal entrance of Duncan

Under my battlements. *Shakspeare. Macbeth.*

Thriftless ambition, that will *raven* up

hine own life's means. *Shakspeare.*

The cloyed will

That satiate yet unsatisfied desire, that tub

Both filled and running, *ravens* first the lamb,  
Longs after for the garbage. *Id. Cymbeline.*

Thy desires

Are wolfish, bloody, starved, and *ravenous*.

*Shakspeare.*

He made the greedy *ravens* to be Elias' caterers  
and bring him food. *King Charles.*

As when a flock

Of *ravenous* fowl, through many a league remote,  
Against the day of battle, to a field  
Where armies lie encamped come flying, lured  
With scent of living carcasses.

*Milton's Paradise Lost.*

To me, who with eternal famine pine,

Alike is hell, or paradise, or heaven;

There best, where most with *ravin* I may meet.

*Milton.*

The *ravenousness* of a lion or bear are natural to  
them; yet their mission upon an extraordinary occa-  
sion may be an *actus imperatus* of divine providence.

*Hale.*

I have seen a perfectly white *raven*, as to bill as  
well as feathers. *Boyle on Colours.*

On several parts a several praise bestows,

The ruby-lips, and well-proportioned nose,

The snowy skin, the *raven* glossy hair,

The dimpled cheek.

*Dryden's Cymon and Iphigenia.*

The more they fed, they *ravened* still for more,

They drained from Dan, and left Beersheba poor;

But when some lay preferment fell by chance,

The Gourmands made it their inheritance. *Dryden.*

They might not lie in a condition exposed to the  
*ravin* of any vermin that may find them, being unable  
to escape. *Ruy.*

What! the kind Ismena,

That nursed me, watched my sickness! oh she  
watched me,

As *ravenous* vultures watch the dying lion. *Smith.*

The *raven* once in snowy plumes was dress'd,

White as the whitest dove's unsullied breast,

His tongue, his prating tongue, had changed him  
quite

To sooty blackness from the purest white. *Addison.*

Convulsions rack man's nerves, and cares his  
breast,

His flying life is chased by *ravens* pains

Through all his doubles in the winding veins.

*Blackmore.*

Hence Gildon rails, that *raven* of the pit,

Who thrives upon the carcasses of wit. *Young.*

RAVEN, in ornithology. See CORVUS.

RAVENNA, a large town in the east of Italy,  
and states of the church, situated in a marshy  
district at the mouth of the Montone. In the  
time of the Lower empire it stood on a bay of  
the Adriatic, and had a considerable port, sepa-  
rated from the city by the Via Cæsaris; but this  
port is now filled up with mud, and the city,  
though still occupying its former site, as proved  
by the ancient monuments it contains, is now at  
a distance of three or four miles from the sea.  
The situation is pleasant, though unhealthy from  
the marshy nature of the ground. This has been  
partly remedied by carrying along the side of the  
town the rivers Montone and Ronco. In former  
times Ravenna was surrounded with lagunes: at  
present, though encircled with a mound, it is not  
a place of strength. Its streets are straight and  
broad, but gloomy; and the town has a deserted  
aspect. The most interesting objects are the mo-  
numents of antiquity, in particular the ruins of  
the palace of Theodoric, and the Porta Aurea, a  
splendid gate of marble. Smaller monuments,  
as mosaics, bas reliefs, and statues, are found in

all parts of the town. The cathedral is a fine modern edifice, having its nave supported by four ranges of columns of Grecian marble. The octagon church of St. Vitale, erected about the sixth century, is likewise supported by pillars of Grecian marble, brought from Constantinople. Another church, called the Rotonda, and situated outside of the town, was built in honor of Theodoric, by his daughter Amalasonda. Ravenna contains likewise the tomb of Dante. It was made a Roman colony by Augustus: Tiberius repaired its walls, and made other improvements; and the emperor Honorius made it the seat of his residence. Theodoric, king of the Ostrogoths, having, in the latter part of the fifth century, become master of Italy, fixed here the seat of his empire, and erected several buildings. Ravenna was also the residence of the imperial lieutenants in the reign of Justinian; and Longinus, the successor of Narses, took the title of exarch, borne by the governors of Italy during 175 years that they resided at Ravenna. The exarchate was brought to a close in the eighth century, by Pepin, father of Charlemagne, who made it over to the see of Rome. On Easter day, 1512, a battle was fought in the neighbourhood between the French and Spaniards, in which the former took Ravenna by assault, and plundered it in a manner which it never recovered. The town has given birth to several eminent men, and is still the see of an archbishop, and the residence of a papal legate. Its manufactures, chiefly of silk, are inconsiderable, but it has a great annual fair. Population 12,000. Forty miles east of Bologna, and seventy north-east of Florence.

RAVENNA (John de), otherwise called Malplaghino, was born in Ravenna in 1352. He studied under Donatus the grammarian. After a wandering life, for some years, he settled at Padua, where Sicco, one of his scholars, says he taught the Roman eloquence and moral philosophy, with applause and success beyond all the professors of that period. In 1397, his forty-fifth year, John was invited by the magistrates of Florence to settle in that city, where he taught many learned men. He died about 1418.

RAUGHT. The disused pret. and part. pass. of REACH. Snatched; reached; attained.

His tail was stretched out in wondrous length,  
That to the house of heavenly gods it *raught*,

And with extorted power and borrowed strength,  
The ever-burning lamps from thence it brought.

*Spenser.*

Gritus, furiously running in upon Schenden, violently *raught* from his head his rich cap of sables, and with his horsemen took him.

*Knolles.*

The hand of death has *raught* him.

*Shakespeare.*

RAVILLIAC (Francis), the assassin of Henry IV. of France, was a native of Angoulesme, and at the time of his execution about thirty-two years of age. Ravillac's parents lived upon alms. His father was an inferior retainer to the law, and his son had been bred up in the same profession. Ravillac had set up a claim to an estate, but the cause went against him, which affected his mind. He afterwards kept a school, and received gifts of small value from the parents of those whom he taught. When he was put to the torture, he broke out in horrid execrations,

but always insisted that he acted from his own impulse, and that he could accuse nobody. On the day of his execution, after he had made the amende honourable before the church of Notre Dame, he was carried to the Greve; and tied to a wooden engine in the shape of a St. Andrew's cross. His right hand, with the knife with which he did the murder fastened in it, was first burnt in a slow fire; then the fleshy parts of his body were torn with red-hot pincers, and melted lead, oil, pitch, and rosin poured into the wounds. The people refused to pray for him; and when, according to the sentence pronounced upon him, he came to be dragged to pieces by four horses, one of those that were brought appearing to be but weak, one of the spectators offered his own, with which the criminal was much moved: he is said to have then made a confession, which was so written by the greffier Voisin that not one word of it could ever be read. He was very earnest for absolution, which his confessor refused, unless he would reveal his accomplices; 'give it me conditionally,' said he, 'upon condition that I have told the truth,' which he did. His body was so robust, that it resisted the force of the four horses; and the executioner was at length obliged to cut him into quarters, which the people dragged through the streets. The house in which he was born was demolished, and a column of infamy erected; his father and mother were banished from Angoulesme, and ordered to quit the kingdom upon pain of being hanged, if they returned, without any form of process; his brothers, sisters, uncles, and other relations, were commanded to lay aside the name of Ravillac, and to assume some other. Such was the fate of this murderer, who, according to his own account, suffered himself to be impelled to the act by the seditious sermons and books of the Jesuits, whom Henry, rather out of fear than love, had recalled and caressed. Neither the dying words of Ravillac, nor so much of his process as was published, were credited, by his contemporaries. Various reports were circulated which it is unnecessary to recapitulate, as they were totally unsupported by any evidence. See FRANCE.

RAVISH, *v. a.* Fr. *ravir*; Ital. *rapire*; Lat. *rapio*. To constuprate by force; deflower by violence; take away violently; overcome the senses; hence transport with pleasure.

e thou *ravished* always with her love.

*Proverbs.*

They *ravished* the women and maidens.

*Lam. v. 11.*

They are cruel and bloody, common *ravishers* of women, and murderers of children.

*Spenser.*

They cut thy sister's tongue, and *ravished* her.

*Shakespeare.*

These hairs which thou dost *ravish* from my chin, Will quicken and accuse thee.

*Id. King Lear.*

Of his several *ravishments*, betrayings and stealing away of men's wives, came in all those ancient fables of his transformations and all that rabble of Grecian forgeries.

*Raleigh.*

As all the housewiferies of deities are

To hear a voice so *ravishingly* fair.

*Chapman.*

A *ravisher* must repair the temporal detriment to the maid, and give her a dowry, or marry her if she desire it.

*Taylor.*

Tell them ancient stories of the *ravishment* of chaste maidens.

*Id. Rule of Holy Living.*

What a *ravishment* was that, when, having found out the way to measure Hiero's crown, he leaped out of the bath, and, as if he were suddenly possest, ran naked up and down!

*Wilkins.*

Can any mortal mixture of earth's mould  
Breathe such divine enchanting *ravishment*?

*Milton.*

I owe myself the care,  
My fame and injured honour to repair;  
From thy own tent, proud man, in thy despite,  
This hand shall *ravish* thy pretended right.

*Dryden.*

Turn hence those pointed glories of your eyes;  
For if more charms beneath those circles rise,  
So weak my virtue, they so strong appear,  
I shall turn *ravisher* to keep you here.

*Id.*

I told them I was one of their knight errants that delivered them from *ravishment*.

*Id.*

But when in beauty's light  
She meets my *ravished* sight,  
When through my very heart  
Her beaming glories dart;

'Tis then I wake to life, to light, and joy.

*Burns.*

**RAVITZ**, or **RAWITSCH**, a fortified town of Prussian Poland, near the confines of Silesia. It has a wall and ditch; four gates; is regularly built, and the streets generally paved. Of the 8000 inhabitants 1200 are Jews; the rest chiefly Lutherans. It has manufactures of woollen, linen, hats, and leather. The town was erected by fugitives from Germany, during the thirty years' war. In 1704 Charles XII. of Sweden took up his winter quarters here; but in 1707 the Russians plundered and burned it down. In 1802 the greatest part was again burned by an accidental fire. Fifty-five miles south of Posen.

**RAUJESHY**, an extensive district of Bengal, situated principally between 24° and 25° of N. lat. It is intersected and watered in its whole length by the Ganges and other rivers. It produces four-fifths of the silk exported from Bengal, and contains Moorshudabad, Baulea, Commercolly, and Bogwangola, and 1,500,000 inhabitants. The zeminary of this district had been long possessed by a Hindoo family, the last of whom, dreading the tyranny of the nabob Moorshud Cooly Jaffier Khan, terminated his own existence, and the zeminary was transferred about the year 1722 to a person named Ramjeon, whose family still retain it.

**RAURICUM**, in ancient geography, a town of the Raurici, situated over against Abnoba, a mountain from which the Danube takes its rise. It was a Roman colony, led by Lucius Munatius Plancus, the scholar and friend of Cicero; called Colonia Rauriaca, by Pliny, Raurica, and Augusta Rauricorum. The town was destroyed in Julian's time.

**RAUVOLFIA**, a genus of the monogynia order, and pentandria class of plants; natural order thirtieth, cortortæ. It is named after the celebrated botanist Rauwolf.

**RAUWOLF** (Leonard), a learned physician and botanist of the sixteenth century, born in Augsburg. To acquire the knowledge of botany, he travelled through Syria, Arabia, and America. He published an Account of his Travels, which

was translated and printed in England in 1693. Being persecuted for his religious opinions, he retired to Linton, where he died in 1606. His *Flora Orientalis* was published at Leyden 1755.

**RAW**, *adj.*

**RAW BONED**, } *Belg. raco, rawo*; Goth. }  
**RAW HEAD**, *n. s.* } and *Swed. ra*. Uncooked;  
**RAWLY**, *adv.* } unwrought; bare or stripped  
**RAWNESS**, *n. s.* } of skin; sore; unripe; new; crude; bleak; chill: rawboned is having bones scarcely covered with flesh: raw-head, a supposed spectre or hobgoblin: the adverb and noun substantive following correspond with raw.

If there be quick *raw* flesh in the risings, it is an old leprosy.

*Leviticus* xiii. 50.

Full of great lumps of flesh, and goblets *raw*.

*Spenser.*

They carried always with them that weed, as their house, their bed, and their garment; and, coming lately into Ireland, they found there more special use thereof, by reason of the *raw* cold climate.

*Id. State of Ireland.*

All aloud the wind doth blow,

And coughing drowns the parson's saw;

And birds sit brooding in the snow,

And Marian's nose looks red and *raw*.

*Shakespeare.*

I have in my mind

A thousand *raw* tricks of these bragging jacks.

*Id.*

Youthful still in your doublet and hose, this *raw* rheumatick day.

*Id.*

Lean *rawboned* rascals! who would e'er suppose They had such courage?

*Id.*

Some crying for a surgeon, some upon the debts they owe, some upon their children *rawly* left.

*Id. Henry V.*

Why in that *rawness* left he wife and children, without leave taking?

*Id. Macbeth.*

Some people, very *raw* and ignorant, are very unworthily and unfitly nominated to places, when men of desert are held back and unpreferred.

*Raleigh's Essays.*

Distilled waters will last longer than *raw* waters.

*Bacon.*

Charles V., considering the *rawness* of his seamen established a pilot major for their examination.

*Hakewill.*

The fire digests the *rawness* of the night.

*Bp. Hall. Contemplation.*

Sails were spread to every wind that blew,  
*Raw* were the sailors and the depths were new.

*Dryden.*

Hence draw thy theme, and to the stage permit  
*Rawhead* and bloody bones, and hands and feet,  
Ragouts for Tereus or Thyestes drest.

*Id.*

The wolf was content to barter away a *rawboned* carcass for a smooth and fat one.

*L'Estrange.*

Servants awe children, and keep them in subjection, by telling them of *rawhead* and bloody bones.

*Lucho.*

People, while young and *raw*, and soft-natured, are apt to think it an easy thing to gain love, and reckon their own friendship a sure price of another man's; but, when experience shall have once opened their eyes, they will find that a friend is the gift of God.

*South.*

**RAWANKRAD**, a noted long and narrow lake in the mountains of Thibet, to the north of the great Himmaleh range. It is connected with the lake Mansorawar, and gives rise to the

Suttelege. It is divided by an island and fed by several small rivers, and by the melting of the snow, with which the neighbouring mountains are always covered. In its vicinity is to be seen Mount Cailas, a celebrated scene of Hindoo fable. It is situated about 31° of N. lat., and was visited in the year 1812 by Mr. Moorcroft.

RAWLEY (William), D. D., a learned divine, born at Norwich, about 1518. He studied at Benet College, Cambridge; took his degree of A. B. in 1604; A. M. in 1608; B. D. in 1615; and D. D. in 1621. In 1609 he was chosen fellow; took orders in 1611, and was appointed rector of Landbeach in 1616. Although he was chaplain to lord Verulam, and afterwards to king Charles I. and II., he never received any higher promotion. During the commonwealth he was ejected by the parliament; but survived their power, and was restored to his living, which he held till his death, June 18th, 1667. He was married and had a son

RAWLINS (Thomas), a dramatic writer, who was engraver for the mint under Charles I. and II. He wrote three plays, entitled Rebellion, Tom Essence, and Tunbridge Wells; and died in 1670.

RAWLINSON (Richard), LL.D., an eminent English antiquary, educated at St. John's College, Oxford, where he took his degrees in 1713 and 1719. He made large collections for the continuation of Wood's Athenæ Oxonienses, and History of Oxford; which, with notes of his own travels, he bequeathed to the university. He promoted the publication of many books of history and antiquities, with particular descriptions of several counties in England. In 1728 he translated and published Fresnoy's new mode of studying history, with a catalogue of the chief historians, 2 vols. 8vo. In 1750 he founded an Anglo-Saxon professorship at Oxford; and bequeathed to that university a large collection of books and medals, and also his heart in a marble urn. He died at Islington in 1755.

RAWLINSON (Christopher, esq.), of Clarkhall, in Lancashire, another learned antiquary, was born in 1677, and educated at Queen's College, Oxford. He became eminent for his skill in Saxon and northern literature; and published a beautiful edition of king Alfred's Saxon translation of Boethius de Consolatione, Oxford 1698, 8vo. He died January 8th, 1733, leaving a great collection of MSS.

RAWLINSON (Thomas), a learned collector of books, commemorated in Addison's Tatler, under the name of Tom Folio. He collected such a quantity of books that he took a large house on purpose for them. He died in 1725, aged forty-four, and the sale of his library lasted three months.

RAY (John), a celebrated botanist, was born at Black Notley in Essex, in 1628. He received the first rudiments of education at the grammar-school at Braintree; and in 1644 was admitted into Catharine Hall, Cambridge, whence he afterwards removed to Trinity College in that university. He took the degree of M. A. and became at length a senior fellow of the college; but his intense application to his studies having

injured his health, he was obliged to exercise himself by riding or walking in the fields, which led him to the study of plants. In 1660 he published his *Catalogus Plantarum circa Cantabrigiam nascentium*, and was ordained deacon and priest. In 1661 he made a tour through Britain along with Mr. Willughby, in search of rare plants; and in 1662 accompanied him in a tour through Holland, Germany, France, and Italy; and on his return was made F. R. S. In 1672 Mr. Willughby dying left Ray one of his executors, and tutor to his sons, with £60 a year for life. For their use he composed his *Nomenclator Classicus*, in 1672. In 1673 he married a daughter of Mr. Oakley, of Launton, Oxfordshire; and published his *Observations Topographical and Moral, &c.*, made in foreign countries; to which was added his *Catalogus Stirpium in Exteris Regionibus Observatarum*; and about the same time his *Collection of Unusual or local English Words*, which he had gathered up in his travels through the counties of England. In 1697 he published the *Wisdom of God manifested in the Works of the Creation*, 8vo. The rudiments of this work were read in some college lectures; and another collection of the same kind he enlarged and published under the title of *Three Physico-Theological Discourses, concerning the Chaos, Deluge, and Dissolution of the World*, 8vo. 1692. He died in 1705. He was modest, affable, and communicative; and was distinguished by his probity and piety. He wrote a great number of other works; the principal of which are, 1. *Catalogus Plantarum Angliæ*. 2. *Dictionariolum Trilingue secundum Locos Communes*. 3. *Historia Plantarum, Species hactenus Editas, aliasque insuper noviter multas Inventas et Descriptas, Complectens*, 3 vols. 4. *Methodus Plantarum Nova, cum Tabulis*, 8vo., and several other works on plants. 5. *Synopsis Methodica Animalium, Quadrupedum et Serpentinum Generis*, 8vo. 6. *Synopsis Methodica Avium et Piscium*. 7. *Historia Insectorum, Opus Posthumum*. 8. *Methodus Insectorum*. 9. *Philosophical Letters, &c.*

RAY, *n. s. & v. a.* Fr. *raie*; Span. *rago*; Ital. *raggio*; Lat. *radius*. A beam of light; any lustre, natural or artificial; a mental beam: as an obsolete verb active, to streak with ray-like lines.

Before a bubbling fountain low she lay,  
Which she increased with her bleeding heart,

And the clean waves with purple gore did *ray*.

*Spenser.*

His horse is *raied* with the yellows. *Shakespeare.*

These eyes that roll in vain

To find thy piercing *ray*, and find no dawn

*Milton.*

The least light, or part of light, which may be stopt alone, or do or suffer any thing alone, which the rest of the light doth not or suffers not, I call a *ray* of light.

*Newton.*

Sol through white curtains shot a tim'rous *ray*,  
And op'd those eyes that must eclipse the day.

*Pope.*

Then kneeling down, to Heaven's Eternal King,

The saint, the father, and the husband prays

Hope "springs exulting on triumphant wing,"

That thus they all shall meet in future days

There ever bask in uncreated *rays*,

No more to sigh, or shed the bitter tear,  
Together hymning their Creator's praise. *Burns.*

RAY, in optics. See LIGHT and OPTICS.

RAYS, INFLECTED, those rays of light which, on their near approach to the edges of bodies, in passing by them, are bent out of their course, being turned either from the body or towards it. This property of the rays of light is generally termed diffraction by foreigners, and Dr. Hooke sometimes called it deflection.

RAYS, PENCIL OF, a number of rays issuing from a point of an object, and diverging in the form of a cone.

RAYS, REFLECTED, those rays of light, which, after falling upon the body, do not go beyond the surface of it, but are thrown back again.

RAYS, REFRACTED, those rays of light which, after falling upon any medium, enter its surface, being bent either towards or from a perpendicular to the point on which they fell.

RAYNAL (William Thomas), the celebrated abbé, was born in 1712: educated among the Jesuits, and had even become a member of their order; but was expelled for denying the supreme authority of the church. He afterwards associated with Voltaire, D'Alembert, and Diderot, and was by them employed to furnish the theological articles for the Encyclopedie. In this, however, he received the assistance of the abbe Yvon, to whom he did not give above a sixth part of what he received; which being afterwards discovered, he was obliged to pay Yvon the balance. His most celebrated work is his Political and Philosophical History of the European Settlements in the East and West Indies; which has been translated into all the languages of Europe, and much admired. This work was followed in 1780 by another, entitled The Revolution of America, in which the abbé pleads the cause of the Americans with zeal. The French government commenced a prosecution against him for the former of these works; upon which he retired to Berlin, where Frederick the Great afforded him an asylum. The chief trait in Raynal's character was his love of liberty; but, when he saw the length to which the French revolutionists were going, he made one effort to stop them in their career. In May, 1791, he addressed a letter to the Constituent National Assembly, in which, after complimenting them upon the great things they had done, he cautioned them against the dangers of going farther. He lived not only to see his forebodings of public calamity realised, but to suffer his share of it. After being stripped of all his property, which was considerable, by the robbers of the revolution, he died in poverty, in March 1796, in the eighty-fourth year of his age. Besides the works above mentioned, he wrote, 1. A History of the Parliament of England. 2. A History of the Stadtholderate. 3. The History of the Divorce of Catharine of Arragon by Henry VIII. About the time of his death, he was preparing a new edition of all his works, with many alterations; and he is said to have left among his MSS. A History of the Revocation of the Edict of Nantes, in 4 vols; but during the bloody reign of Robespierre he burnt a great number of his MSS.

RAZE, *n. s.* Span. *rayz*, a root. A root of ginger. Written also *race*, but less properly.

I have a gammon of bacon and two *razes* of ginger to be delivered. *Shakspeare, Henry IV.*

RAZE, *v. a.* } Fr. *raser*; Lat. *rasus*. See  
RA'ZURE, *n. s.* } RASE. To overthrow; ruin;  
subvert; efface: razure, the act or mark of razing.  
Will you suffer a temple, how poorly built soever,  
but yet a temple of your deity, to be razed?

*Sidney.*  
It grieved the tyrant that so base a town should so long hold out, so that he would threaten to raze it.  
*Knolles.*

He yoaketh your rebellious necks,  
*Razeth* your cities, and subverts your towers.

Pluck from the memory a rooted sorrow,  
*Raze* out the written troubles of the brain. *Id.*

Oh! your desert speaks loud  
It well deserves with characters of brass  
A fortified residence, 'gainst the tooth of time  
And *razure* of oblivion. *Id.*

He in derision sets  
Upon their tongues a various spirit, to raze  
Quite out their native language; and instead  
To sow a jangling noise of words. *Milton.*  
Shed Christian blood, and populous cities raze;  
Because they're taught to use some different phrase.  
*Waller.*

We touched with joy  
The royal hand that *razed* unhappy Troy.

*Dryden.*  
The place would be *razed* to the ground, and its foundations sown with salt. *Addison's Spectator*

RA'ZOR, *n. s.* } Fr. *razoir*; Lat. *rasor*. A  
RA'ZORFISH. } knife used in shaving: a fish,  
so called from its shape.

Zeal, except ordered aright, useth the *razor* with such eagerness that the life of religion is thereby hazarded.

*Hooker.*  
These words are *razors* to my wounded heart.  
*Shakspeare.*  
New-born chins be rough and *rasourable*. *Id.*  
The sheath or *razorfish* resembleth in length and bigness a man's finger. *Carew.*

Those thy boisterous locks, not by the sword  
Of noble warrior, so to stain his honour,  
But by the barber's *razor* best subdued. *Milton.*  
*Razor* makers generally clap a small bar of Venice steel between two small bars of Flemish steel, and weld them together, to strengthen the back of the *razor*. *Moxon.*

As in smooth oil the *razor* best is whet,  
So wit is by politeness sharpest set,  
Their want of edge from their offence is seen;  
Both pain us least when exquisitely keen. *Young.*

REACCESS, *n. s.* Re and access. Renewed visit.

Let pass the quailing and withering of all things  
by the recess, and their reviving by the *reaccess* of  
the sun. *Hakevill.*

REACH, *v. a., v. n. & n. s.* Sax. *reacan*; Belg. *rekken*; Goth. *reckia*. To attain; penetrate or be adequate to; arrive at; touch, strike, or fetch, from a distance; hold out; give: as a verb neuter, be extended; penetrate; be far extended; endeavour: as a noun substantive reach is power of touching, taking, or compassing; limit of faculties; attainment; authority; range; extent; scheme; device; fetch.

He hath delivered them into your hand, and ye have slain them in a rage, that *reacheth* up unto heaven.  
*2 Chronicles xxviii.*

*Reach* hither thy finger, and behold my hands ;  
and *reach* hither thy hand, and thrust it into my  
side. *John* xx. 27.

He *reached* me a full cup. *2 Esdras* xiv. 39.

These kinds of goodness are so nearly united to  
the things which desire them, that we scarcely per-  
ceive the appetite to stir in *reaching* forth her hand  
towards them. *Hooker*.

We hold that the power which the church hath  
lawfully to make laws, doth extend unto sundry  
things of ecclesiastical jurisdiction, and such other  
matters whereto their opinion is, that the church's  
authority and power doth not *reach*. *Id.*

Great men have *reaching* hands. *Shakspeare*.

Strain not my speech

To grosser issues, nor to larger *reach*,

Than to suspicion. *Id. Othello*.

The duke of Parma had particular *reaches* and  
ends to his own underhand, to cross the design. *Bacon*.

Some, under types, have affected obscurity to  
amuse and make themselves admired for profound  
*reaches*. *Howel*.

Round the tree

They longing stood, but could not *reach*.

Thy desire leads to no excess that *reaches* blame. *Milton*.

Least he *reach* of the tree of life, and eat. *Id.*

The confines met of empyrean heaven,  
And of this world : and, on the left hand, hell

With long *reach* interposed. *Id. Paradise Lost*.

The new world *reaches* quite cross the torrid zone  
in one tropick to the other. *Boyle*.

The coast so long desired

Thy troops shall *reach*, but having *reached*, *repent*.

*Dryden*.

What remains beyond this, we have no more a  
positive notion of, than a mariner has of the depth  
of the sea ; where, having let down his sounding line,  
he *reaches* no bottom. *Locke*.

When men pursue their thoughts of space, they  
are apt to stop at the confines of body, as if space  
were there at an end too, and *reached* no farther. *Id.*

There may be in a man's *reach* a book containing  
pictures and discourses, capable to delight and in-  
struct him, which yet he may never have the will to  
open. *Id.*

Through such hands

The knowledge of the gods is *reached* to man. *Rowe*.

Here imprecations *reach* not to the tomb,  
They shut not out society in death. *Addison's Cato*.

What are riches, empire, power,  
But larger means to gratify the will ;

The steps by which we climb to rise and *reach*

Our wish, and, that obtained, down with a scaffolding

Of sceptres, crowns, and thrones : they've served

their end,

And there like lumber to be left and scorned ? *Congreve*.

The best accounts of the appearances of nature,  
which human penetration can *reach*, come short of  
its reality. *Cheyne*.

It must fall perhaps before this letter *reaches* your  
hands. *Pope*.

Be sure yourself and your own *reach* to know,  
How far your genius, taste, and learning go. *Id.*

The influence of the stars *reaches* to many events,  
which are not in the power of reason. *Swift*.

REACT, *v. a.* } Re and act. To return

REACTION, *n. s.* { an impulse or impression :  
the noun substantive corresponding.

Do not great bodies conserve their heat the longest,  
their parts heating one another ; and may not great,  
dense, and fixed bodies, when heated beyond a cer-  
tain degree, emit light so copiously as by the  
emission and *reaction* of its light, and the reflections  
and refractions of its rays within its pores, to grow  
still hotter till it comes to a certain period of heat,  
such as that of the sun ? *Newton's Opticks*.

The lungs being the chief instrument of sanguifica-  
tion, and acting strongly upon the chyle to bring it  
to an animal fluid, must be *reacted* upon as strongly. *Arbuthnot*.

Cut off your hand, and you may do

With t'other hand the work of two ;

Because the soul her power contracts,

And on the brother limb *reacts*. *Swift's Miscellanies*.

READ, *v. a., v. n. & n. s.* } Sax. *ræð* ; Teut.

READER, *n. s.* } *reden* ; Goth. *reda*,

READERSHIP, } *ruda*, to explain or

READING. } divine. To peruse ;

discover by marks or characters ; hence learn by  
observation of any kind ; to perform the act of  
reading ; be studious ; know by reading : as an  
obsolete noun substantive, counsel ; saying :  
a reader is he who reads ; who is studious ; or  
whose office it is to read in public : readership,  
his office : reading is public recital ; study ; varia-  
tion of copies.

It shall be with him, and he shall *read* therein,  
that he may learn to fear the Lord. *Deut.* xvii. 19.

Give attendance to *reading*, exhortation, and doc-  
trine. *1 Timothy*.

The man is blest that hath not lent

To wicked *read* his ear. *Sternhold*.

This *reade* is rife that oftentime

Great cumpers fall unsoft,

In humble dales is footing fast,

The trade is not so tickle. *Spenser*.

An armed corse did lye,

In whose dead face he *read* great magnanimity. *Id.*

The Jews had their weekly *readings* of the law. *Hooker*.

I have seen her take forth paper, write upon't,

*read* it, and afterwards seal it. *Shakspeare*.

O most delicate fiend !

Who is't can *read* a woman ?

As we must take the care that our words and  
sense be clear ; so, if the obscurity happen through  
the hearers or *readers* want of understanding, I am  
not to answer for them. *Ben Jonson*.

'Tis sure that Fleury *reads*. *Taylor*.

Virgil's shepherds are too well *read* in the philoso-  
phy of Epicurus. *Dryden*.

Basiris' altars, and the dire decrees

Of hard Euresatheus, every *reader* sees. *Id.*

Till a man can judge whether they be truths or no,  
his understanding is but little improved : and thus  
men of much *reading* are greatly learned, but may be  
little knowing. *Locke*.

We have a poet among us, of a genius as exalted  
as his stature, and who is very well *read* in Longinus,  
his treatise concerning the sublime. *Addison*.

That learned prelate has restored some of the  
*readings* of the authors with great sagacity. *Arbuthnot on Coins*.

The passage you must have *read*, though since  
slipt out of your memory. *Pope*.

Less *reading* than makes felons 'scape,

Less human genius than God gives an ape, *Id.*

Can make a Ciber. *Id.*

I have *read* of an eastern king, who put a judge to  
death for an iniquitous sentence. *Swift*.

He got into orders, and became a *reader* in a parish church at twenty pounds a year. *Id.*

When they have taken a degree, they get into orders, and solicit a *readership*. *Id. Miscellanies.*

Though *reading* and conversation may furnish us with many ideas of men and things, yet it is our own meditation must form our judgment.

*Watts on the Mind.*

**READEPTION**, *n. s.* Lat. *re* and *adeptus*. Recovery; act of regaining.

Will any say that the *readepcion* of Trevigi was matter of scruple? *Bacon.*

**READING**, a borough, market and county-town in the county of Berks, is thirty-nine miles west by south from the metropolis, on the high road from London to Bath. It is of considerable extent and importance, and is unquestionably of very great antiquity; but whether it is indebted for its origin to the Britons, the Romans, or the Saxons, is unknown. In 1389 a great council was held at Reading, at which the king and his barons were reconciled by John of Gaunt. Parliaments were held here in 1440 and 1451; in the former of which the order of viscounts was first established; and in the year following the parliament adjourned hither from Westminster, on account of the plague. Edward IV.'s marriage with Elizabeth, lady Grey, was first acknowledged at Reading, in 1464; on which occasion she made her public appearance at the abbey, conducted by the duke of Gloucester and the earl of Warwick. In 1466 parliament was a second time adjourned to Reading, to avoid the plague. King Henry VIII. frequently resided here at the dissolved abbey. His son, king Edward VI., visited the town in 1552, when he was met by the mayor and aldermen at Coley-Cross, and presented with two yokes of oxen. The same ceremony was repeated when Reading was visited by the bigotted Mary, and her husband, Philip of Spain. When, early in the reign of Charles I., the plague raged with great violence in the metropolis, all the great courts of law were held here. In 1642 Reading was a parliamentary post; but the garrison, wanting ammunition, quitted the town, without resistance, on the approach of the king's horse. In consequence of this event it became a royal garrison, and continued to be so till taken by Essex in April 1643, after a siege of eight days. The king, however, again recovered it in September, and held it till May 1644, when he ordered the works to be demolished. Reading was afterwards frequently occupied as the head quarters of the parliamentary army, and much impoverished by the contributions levied upon it. In 1688 the army of king James II. was quartered in this town, but quitted it on the approach of the prince of Orange. In 1700 queen Anne visited Reading, when she was received by the corporation in state, and presented with forty broad pieces of gold in an elegant purse.

The first monarch who conferred upon Reading the privilege of separate jurisdiction was Henry III. His charter was confirmed by all his successors, but without any material alterations, till the reign of Henry VI., when the corporation is first mentioned by the title of the mayor and burgesses. Charles I. authorised alder-

men to be elected, and invested them with ample powers for the government of the town. This charter was confirmed, after the restoration, by Charles II., and is the one now extant. By it the officers are declared to be a mayor, twelve aldermen, and the same number of capital burgesses; the mayor, and his deputy (the preceding mayor), the senior alderman, the bishop of Salisbury, and his chancellor, being justices of the peace for the borough, and empowered to hold sessions, and a court of record. Reading sent members to parliament from the time of the earliest records. Before 1716 the right of election was vested in the freemen not receiving alms, and in the inhabitants paying scot and lot; but in that year it was limited, by a decision of the house of commons, to the inhabitants paying scot and lot only. The number of voters is large, and the mayor is the returning officer.

The town is situated on both banks of the river Kennet, which here separates itself into several branches. It contains three parishes, St. Giles, St. Mary, and St. Lawrence. Formerly it was a place of great trade in woollens, but that manufacture fell to decay during the seventeenth century, and has never since revived. The principal support of the town arises from its water communications with London, Bath, and Bristol. The articles exported are flour, timber, bark, straight hoops, and a variety of minor articles. Many improvements have been lately made in the internal navigation of the district.

Its markets are held weekly, on Wednesday and Saturday, and there are four annual fairs. The houses are mostly of brick, and the streets regular, spacious, well lighted, and paved. Within the last few years the town has greatly increased in size, and a new town has sprung up to the westward of the old one. Along the Oxford and London roads, also, many well built rows of houses have been lately erected.

The principal public buildings and institutions in the town are the three churches of St. Lawrence, St. Mary, and St. Giles; a handsome episcopal chapel recently erected by the Rev. George Hulme; and several dissenting meeting-houses; the town-hall and free-school, blue-coat school, green-school, foundation school, the school of industry, Lancasterian school, school for national education, the theatre, and the county gaol.

The ruins of the ancient monastery are also an object of considerable attraction. The church of St. Lawrence was chiefly erected towards the close of the sixteenth century, and is partly constructed of materials taken from the buildings of the abbey. St. Mary's church is more ancient than that of St. Lawrence, and its tessellated tower is much admired. St. Giles's church was probably constructed at the commencement of the twelfth century. The tower only is modern, the ancient one having been demolished during the civil war. This church has recently undergone complete repair. The meeting-houses belong to the Independents, Baptists, Quakers, Methodists, Unitarians, and Catholics.

The town hall and free-school form one building; the free-school occupying the ground story, and the hall, court room, and offices, the floor above. The free-school was established in the



reign of Henry VII., by John Thorne, abbot of Reading, with the funds of a suppressed almshouse. The blue-coat school was founded in 1656 by Mr. Richard Aldworth, who bequeathed £4000 for the support of a master, lecturer, and twenty boys. The green school, situated in Broad-street, is appropriated for the education of the daughters of decayed tradesmen, residents in the town, and of orphans, who have been left unprovided for by their parents. The theatre of Reading is a neat and convenient building, erected under the act for regulating provincial theatres. The gaol is built on the site of some of the abbey ruins. It is a large edifice, and contains commodious apartments for the keeper, a neat chapel, an infirmary, and a room for the reception of the magistrates, in the centre.

Reading has given birth to several persons of eminence, among whom may be named Sir Thomas White, founder of St. John's College, Oxford; archbishop Laud; John Blagrove, the mathematician; Sir Thomas Holt; Sir John Bernard; James Merrick, the translator of the Psalms, &c. &c.

READING, a borough and capital of Berks county, Pennsylvania, on the Schuylkill, fifty-four miles north-west of Philadelphia. Population 3463. It is a very pleasant and flourishing town, and contains a court house, a jail, two banks, a large edifice for the public offices, and four houses of public worship: one for Lutherans, one for Calvinists, one for Roman Catholics, and one for Friends. It is chiefly settled by Germans.

READMIT, *v. a.* Re and admit. To let in again.

These evils I deserve,  
Yet despair not of his final pardon,  
Whose ear is ever open, and his eye  
Gracious to readmit the suppliant. *Milton.*

In an exhausted receiver, animals, that seem as they were dead, revive upon the readmission of fresh air. *Arbuthnot.*

After twenty minutes I readmitted the air. *Derham.*

READORN', *v. a.* Re and adorn. To decorate again, or anew.

The streams now change their languid blue,  
Regain their glory, and their fame renew,  
With scarlet honours readorn the tide. *Blackmore.*

READY, *adj., adv., & n. s.* } Saxon *ræd*;  
READILY, *adv.* } Goth. *rad* (apt,  
READINESS, *n. s.* } prompt.)

Prompt; prepared; fit; willing; eager; quick; nimble; hence, near; at hand; the adverb and noun-substantive corresponding: ready is also sometimes used as an adverb: see the extract from the book of Numbers; and as a noun-substantive, in colloquial discourse, for ready money.

We will go ready armed before the children of Israel. *Numbers.*

Trouble and anguish shall prevail against him, as a king ready to the battle. *Job xv. 24.*

He will shew you a large upper room; there make eady for us. *Mark xiv. 15.*

This mene I now by mighty Theseus,  
That for to huntun is so desirous,  
And namely at the grete hart in May,  
That in his bed ther dawth him ne day

That he n'is clad, and rede for to ride  
With hunte and borne and houndes him beside.

*Chaucer. Cant. Tales.*

Men, when their actions succeed not as they would, are always ready to impute the blame thereon unto the heavens, so as to excuse their own follies.

*Spenser's State of Ireland.*

Sometimes the readiest way which a wise man hath to conquer, is to fly. *Hooker's Preface.*

All things are ready, if our minds be so,  
Perish the man whose mind is backward now!

*Shakspeare.*

I am joyful to hear of their readiness. *Id.*  
He would not forget the readiness of their king in aiding him when the duke of Bretagne failed him.

*Bacon.*

A cloud that is more show than moisture; a cloud that is more ready to bestow his drops upon the sea, than on the land. *Holiday.*

They remained near a month, that they might be in readiness to attend the motion of the arm.

*Clarendon.*

Death ready stands to interpose his dart.

*Milton.*

My tongue obeyed, and readily could name  
Whate'er I saw. *Id.*

The race elect,  
Safe towards Canaan from the shore advance  
Through the wild desert, not the readiest way.

*Id.*

Nature has provided for the readiness and easiness of speech. *Holder.*

These commodities yield the readiest money of any in this kingdom, because they never fail of a price abroad. *Temple.*

He overlooked his hind; their pay was just  
And ready; for he scorned to go on trust.

*Dryden.*

One hand the sword, and one the pen employs  
And in my lap the ready paper lies. *Id.*  
Proud of their conquest, prouder of their prey,  
They leave the camp, and take the readiest way.

*Id.*

The imagination is always restless, and the will, reason being laid aside, is ready for every extravagant project. *Locke.*

I readily grant that one truth cannot contradict another. *Id.*

They who should have helped him to mend things, were readier to promote the disorders by which they might thrive than to set a-foot frugality. *Davenant.*

The ready way to be thought mad is to contend that you are not so. *Spectator.*

Their conviction grew so strong that they embraced the same truths, and laid down their lives, or were always in readiness to do it, rather than depart from them. *Addison.*

A pious and well-disposed mind, attended with a readiness to obey the known will of God, is the surest means to enlighten the understanding to a belief of Christianity. *South.*

Those very things which are declined as impossible, are readily practicable in a case of extreme necessity. *Id.*

Lord Strut was not flush in ready, either to go to law, or clear old debts. *Arbuthnot.*

Those, who speak in publick, are much better accepted, when they can deliver their discourse by the help of a lively genius and a ready memory, than when they are forced to read all. *Watts.*

For the most part there is a finer sense, a clearer mind, a readier apprehension, and gentler dispositions in that sex, than in the other. *Law.*

A ready consort often subjects a woman to contempt. *Id.*

**REAFFIRMANCE**, *n. s.* Re and affirmance.

A second confirmation.

Causes of deprivation are a conviction before the ordinary of a wilful maintaining any doctrine contrary to the thirty-nine articles, or a persisting therein without revocation of his error, or a *reaffirmance* after such revocation.

**REAGENTS**, in chemistry, are such substances as enable the experimenter to draw conclusions as to the nature of the bodies examined by means of the alterations produced by the reagent. In the experiments of chemical analysis, the component parts of bodies may either be ascertained in quantity as well as quality by the perfect operations of the laboratory, or their quality alone may be detected by the operations of certain tests or reagents. Thus the infusion of galls is a reagent, which detects iron by a dark purple or black precipitate; the prussiate of potash exhibits a blue with the same metal, &c. See **TESTS**.

**RE-AGGRAVATION**, in the Romish ecclesiastical law, the last monitory, published after three admonitions, and before the final excommunication. Before they proceed to excommunication, they always publish an aggravation, and a re-aggravation.

**REAL**, *adj.* Fr. *reel*; Lat. *realis*.

**REALITY**, *n. s.* } Genuine; true; intrinsic;  
**REALIZE**, *v. a.* } relating to things, not to  
**REALLY**, *adv.* } persons; in law relating to  
**REALGAR**, *n. s.* } things immoveable, as land, &c.; reality is truth; verity: something intrinsically important: to realise, to bring into act or being; sometimes to convert money into land; sometimes to convert other property into money: really corresponds with real: realgar is a mineral defined below.

Many are perfect in men's humours, that are not greatly capable of the *real* part of business; which is the constitution of one that hath studied men more than books.

Put *realgar* hot into the midst of the quicksilver, whereby it may be condensed as well from within as without.

Nothing properly is his duty but what is *really* his interest.

Of that skill the more thou knowest,  
The more she will acknowledge thee her head,

And to *realities* yield all her shows,

Made so adorn for thy delight the more. *Milton.*

We do but describe an imaginary world, that is but little akin to the *real* one. *Glanville's Scorpis.*

Thus we *realize* what Archimedes had only in hypothesis weighing a single grain against the globe of earth.

We shall at last discover in what persons this holiness is inherent *really*, in what condition it is inherent perfectly, and consequently in what other sense it may be truly and properly affirmed that the church is holy.

I am hastening to convert my small estate, that is personal, into *real*.

As a diocesan, you are like to exemplify and *realize* every word of this discourse.

There cannot be a more important case of conscience for men to be resolved in, than to know certainly how far God accepts the will for the deed, and how far he does not; and to be informed truly when men do *really* will a thing, and when they have *really* no power to do what they have willed.

When I place any imaginary name at the head of a

character, I examine every letter of it, that it may not bear any resemblance to one that is *real*.

I would have them well versed in the Greek and Latin poets, without which a man fancies that he understands a critick, when in *reality* he does not comprehend his meaning.

Imaginary distempers are attended with *real* and unfeigned sufferings, that enfeeble the body, and dissipate the spirits.

The whole strength of the Arian cause, *real* or artificial; all that can be of any force either to convince, or deceive a reader.

The best account of the appearances of nature, in any single instance human penetration can reach, comes infinitely short of its *reality* and internal constitution; for who can search out the Almighty's works to perfection?

I was *really* so diffident of it, as to let it lie by me these two years, just as you now see it.

These orators inflame the people, whose anger is *really* but a short fit of madness.

They even affect to be more pleased with dress, and to be more fond of every little ornament, than they *really* are.

Why *really* sixty-five is somewhat old.

My neck may be an idea to you, but it is a *reality* to me.

**REAL**, the name of a Spanish silver coin. See **COINS**.

**REAL** (Cæsar Vichard de St.), a French writer, who distinguished himself at Paris by several ingenious productions, and died at Chamberry in 1692, at an advanced age. A complete edition of his works was printed in Paris, in 3 vols. 4to., 1745, and another in 6 vols. 12mo.

**REAL** (Gaspard de), lord of Curban and grand seneschal of Forcalquier, was born at Sisteron, in 1682, and became distinguished for his political abilities. He wrote a Treatise on Government, in 8 vols. 4to., Paris, 1762, which was much esteemed. He died in Paris in 1752.

**REALGAR**, in chemistry and mineralogy, the native sulphuret of arsenic.

**REALISTS**, a sect of school philosophers formed in opposition to the nominalists. See **NOMINALISTS**. Under the realists are included the Scotists, Thomists, &c. Their distinguishing tenet is that universals are realities, and have an actual existence out of an idea or imagination; or, as they express it in the schools, a *parte rei*; whereas the nominalists contend that they exist only in the mind, and are only ideas, or methods of conception. Dr. Odo, or Ondard, a native of Orleans, afterwards abbot of St. Martin de Tournay, was the chief of the realists. He wrote three books of dialectics, where, on the principles of Boethius and the ancients, he maintained that the object of that art is things, not words.

**REALM**, *n. s.* Fr. *royaume*. A kingdom; a king's dominion.

Is there any part of that *realm*, or any nation therein, which have not yet been subdued to the crown of England?

They had gathered a wise council to them  
Of every *realm* that did debate this business.

A son whose worthy deeds  
Raise him to be the second in that *realm*.

Learn each small people's genius, policies,  
The ant's republick, and the realm of bees. *Pope.*  
When few from famines or from plagues survive,  
Or earthquakes swallow half the realm alive.

*Darwin.*

REALTY, *n. s.* Ital. *realty*; of Lat. *realitas*. Loyalty to kings.

O heaven, that such resemblance of the Highest  
Should yet remain, where faith and *realty*  
Remain not. *Milton's Paradise Lost.*

*Realty* means not in this place reality in opposition  
to show; but loyalty; for the Italian dictionary ex-  
plains the adjective *reale* by loyal. *Pearce.*

REAM, *n. s.* Sax. *ream*; Fr. *rame*; Belg.  
*riem*. A bundle of paper containing twenty  
quires.

All vain petitions mounting to the sky,  
With *reams* abundant this abode supply. *Pope.*

REANIMATE, *v. a.* Lat. *re* and *animus*.  
To revive; restore to life.

We are our *reanimated* ancestors, and antedate  
their resurrection. *Granville's Scepis.*

The young man left his own body breathless on  
the ground, while that of the doe was *reanimated*.  
*Spectator.*

REANNEX', *v. a.* Re and annex. To an-  
nex again.

King Charles was not a little inflamed with an  
ambition to repurchase and *reannex* that duchy.

*Bacon's Henry VII.*

REAP, *v. a. & v. n.* } Sax. *repan*; Belg.  
REAPER, *n. s.* } *reepen*; Swed. *repa*.  
REAPING-HOOK. } To cut corn at harvest;  
to obtain or gather; to harvest: the reaper is he  
who reaps; and the reaping-hook, his instru-  
ment.

When ye *reap* the harvest, thou shalt not wholly  
*reap* the corners of thy field. *Leviticus xix. 9.*

They that sow in tears, shall *reap* in joy.  
*Psalms.*

The hire of the labourers, which have *reaped* down  
your fields, is kept back by fraud. *James.*

From hungry *reapers* they their sheaves withhold.  
*Sundys.*

They that love the religion which they profess,  
may have failed in choice, but yet they are sure to  
*reap* what benefit the same is able to afford.

*Hooker.*

From Ireland come I with my strength,  
And *reap* the harvest which that rascal sowed.

*Shakspeare.*

What sudden anger's this? how have I *reaped* it?  
*Id.*

Our sins being ripe, there was no preventing of  
God's justice from *reaping* that glory in our calami-  
ties, which we robbed him of in our prosperity.

*King Charles.*

Some are bribed to vow it looks  
Most plainly done by thieves with *reapinghooks*.

*Dryden.*

Here Ceres' gifts in waving prospects stand,  
And nodding tempt the joyful *reaper's* hand.

*Pope.*

REAR, *n. s.* } Fr. *arriere*, of Lat. *retro*.  
REARWARD. } The hinder class; hinder  
troop of an army, or the hinder line of a fleet:  
rearward is also used in these senses.

The standard of Dan was the *rearward* of the  
camp. *Numbers.*

He from the beginning began to be in the *rear-  
ward*, and before they left fighting was too far off.

*Sidney.*

The *rear* admiral, an arch pirate, was afterwards  
slain with a great shot. *Knolles.*

Why followed not, when she said Tybalt's dead,  
Thy father or thy mother?

But with a *rearward* following Tybalt's death,  
Romeo is banished. *Shakspeare. Romeo and Juliet.*  
He was ever in the *rearward* of the fashion.

*Shakspeare.*

Coins I place in the *rear*, because made up of  
both the other. *Peacham.*

Snowy-headed winter leads,  
Yellow autumn brings the *rear*. *Waller.*

Argive chiefs

Fled from his well-known face, with woe'd fear,  
As when his thund'ring sword and pointed spear  
Drove headlong to their ships, and gleaned the  
*rear*. *Dryden.*

REAR, *v. a.* Sax. *aprepan*; Isl. *reira*. To  
raise up; move or life upwards; hence bring to  
maturity; breed; educate.

All the people shouted with a loud voice, for the  
*rearing* up of the house of the Lord. *1 Esdras.*

Down again she fell unto the ground,

But be her quickly *reared* up again. *Spenser.*

No creature goeth to generate, whilst the female  
is busy in sitting or *rearing* her young. *Bacon.*

In adoration at his feet I fell

Submit; he *reared* me. *Id.*

Who now shall *rear* you to the sun, or rank  
Your tribes. *Id.*

Into the naked woods he goes,

And seeks the tusky boar to *rear*,

With well-mouthed hounds and pointed spear.

*Dryden.*

They were a very hardy breed, and *reared* their  
young ones without any care.

*Mortimer's Husbandry.*

Charity decent, modest, easy, kind,  
Softens the high, and *rears* the abject mind. *Prior.*

They have in every town public nurseries, where  
all parents, except cottagers and labourers, are  
obliged to send their infants to be *reared* and edu-  
cated. *Swift.*

He wants a father to protect his youth,

And *rear* him up to virtue. *Southern.*

They flourished long in tender bliss, and *reared*  
A numerous offspring, lovely like themselves.

*Thomson.*

No flesh from market-towns our peasant sought;  
He *reared* his frugal meat, but never bought.

*Harte.*

REAR, *adj.* Sax. *hprepe*. Raw; half-roasted;  
early. A provincial word.

O'er yonder hill does scant the dawn appear,  
Then why does Cuddy leave his cot so *rear*? *Gay.*

REAR GUARD is that body of an army which  
marches after the main body. The old grand  
guards of the camp always form the rear guard  
of the army, and are to see that every thing ar-  
rives safe at the new camp.

REAR-MOUSE, *n. s.* Sax. *prepe mur*. The  
leather-winged bat.

Some war with *rearmice* for their leathern wings  
To make my small elves coats. *Shakspeare.*

Of flying fishes the wings are not feathers, but a  
thin kind of skin, like the wings of a bat or *rear-  
mouse*. *Abbot.*

REASCEND', *v. n. & v. a.* Re and ascend.  
To climb again; mount again.

When as the day the heaven doth adorn,

I wish that night the noyous day would end;

And when as night hath us of light forlorn,

I wish that day would shortly *reascend*. *Spenser.*

Taught by the heav'nly muse to venture down  
The dark descent, and up to *reascend*. Milton.  
When the god his fury has allayed,  
He mounts aloft, and *reascends* the skies. Addison.

REA'SON, *n. s., v. n. & v. a.* Fr. *raison*;  
REA'SONABLE, *adj.* Lat. *ratio*. The  
REA'SONABLENESS, *n. s.* } power by  
REA'SONABLY, *adv.* } which men de-  
REA'SONER, *n. s.* } duce conclu-  
REA'SONING, } sions from an  
REA'SONLESS, *adj.* } argument; rati-  
ocination; discursive art; hence cause, con-  
sidered logically; efficient or final cause;  
reasonable or just claim, account, or practice;  
moderation: to reason is to argue; hence to  
debate; discourse; make enquiry; argue rati-  
onally or correctly; and to examine rationally  
(a gallicism): reasonable, reasonableness, and  
reasonably, correspond with reason as a noun  
substantive: reasoner is he who uses the faculty  
of reason; an arguer: reasoning is argument;  
logic: reasonless, devoid of reason; causeless.

Stand still, that I may *reason* with you of all the  
righteous acts of the Lord. 1 Samuel xii. 7.  
Jesus perceiving their thoughts, said, What *reason*  
ye in your hearts? Luke v. 22.  
She perceived her only son lay hurt, and that his  
hurt was so deadly, as that already his life had  
lost use of the *reasonable* and almost sensible part.  
Sidney.

I was promised on a time,  
To have *reason* for my rhyme:  
From that time unto this season,  
I received nor rhyme nor *reason*. Spenser.  
*Reason* is the director of man's will, discovering  
in action what is good; for the laws of well-doing  
are the dictates of right *reason*. Hooker.  
I mask the business from the common eye  
For sundry weighty *reasons*. Shakespeare. Macbeth.

When valour preys on *reason*,  
It eats the sword it fights with. Shakspeare.  
Are you in earnest?  
—Ay, and resolved withal  
To do myself this *reason* and this right. Id.  
*Reason* with the fellow,  
Before you punish him, where he heard this. Id.  
Let all things be thought upon,  
That may with *reasonable* swiftness add  
More feathers to our wings. Id. Henry V.  
This proffer is absurd and *reasonless*. Shakspeare.  
That they wholly direct the *reasonless* mind, I am  
resolved; for all those which were created mortal,  
as birds and beasts, are left to their natural appetites.  
Raleigh's History of the World.

It was a *reasonable* conjecture, that those countries  
which were situated directly under the tropic, were  
of a *distemper* uninhabitable. Id.  
Spain is thin sown of people, partly by *reason* of  
the sterility of the soil, and partly their natives are  
exhausted by so many employments in such vast ter-  
ritories as they possess. Bacon.  
Some man *reasonably* studied in the law, should be  
persuaded to go thither as chancellor. Id.  
When she rates things, and moves from ground to  
ground,  
The name of *reason* she obtains by this;  
But when by *reason* she the truth hath found,  
And standeth fixt, she understanding is. Davies.  
The parliament was dissolved, and gentlemen fur-  
nished with such forces, as were held sufficient to  
hold in bridle either the malice or rage of *reasonable*  
people. Huyward.

A good way distant from the nigra rupes, there  
are four several lands of *reasonable* quantity.  
Abbot.

Such a benefit, as by the antecedent will of Christ  
is intended to all men living, though all men, by *rea-  
son* of their own demerits, do not actually receive the  
fruit of it. White.

What the apostles deemed rational and probable  
means to that end, there is no *reason* or probability  
to think should ever in any produce this effect.  
Hammond.

God brings good out of evil; and therefore it were  
but *reason* we should trust God to govern his own  
world, and wait till the change cometh, or the *reason*  
be discovered. Taylor.

Is it *reasonable* when I reprove any vicious person  
for dishonouring God, and dissuade him from his  
wicked courses, that he should tell me he will not  
be discouraged by my fine words, but if I will go to  
principles and first grounds he will hear me?  
Bp. Taylor.

By indubitable certainty, I mean that which doth  
not admit of any *reasonable* cause of doubting, which  
is the only certainty of which most things are capa-  
ble. Wilkins.

They thought the work would be better done, if  
those, who had satisfied themselves with the *rea-  
sonableness* of what they wish, would undertake  
the converting and disposing of other men.  
Clarendon.

Though brutish that contest and foul,  
When *reason* hath to deal with force; yet so  
Most *reason* is that *reason* overcome. Milton.  
Down *reason* then, at least vain *reasoning* down.  
Id.

These *reasons* in love's law have past for good,  
Though fond and *reasonless* to some. Id.

The passive *reason*, which is more properly *rea-  
sonableness*, is that order and congruity which is  
impressed upon the thing thus wrought; as in a  
watch, the whole frame and contexture of it car-  
ries a *reasonableness* in it, the passive impression of  
the *reason* or intellectual idea that was in the artist.  
Hale.

To render a *reason* of an effect or phenomenon is  
to deduce it from something else more known than  
itself. Boyle.

Virtue and vice are not arbitrary things, but there  
is a natural and eternal *reason* for that goodness  
and virtue, and against vice and wickedness.  
Tillotson.

When any thing is proved by as good arguments  
as a thing of that kind is capable of, we ought not  
in *reason* to doubt of its existence. Id.

If we can by industry make our deaf and dumb per-  
son *reasonably* perfect in the language and pronun-  
ciation, he may be also capable of the same privilege  
of understanding by the eye what is spoken.  
Holder's Elements of Speech.

Dim, as the borrowed beams of moon and stars  
To lonely, weary, wandering travellers,  
Is *reason* to the soul: and as on high,  
Those rolling fires discover but the sky,  
Not light us here; so *reason's* glimmering ray  
Was lent, not to assure our doubtful way,  
But guide us upward to a better day. Dryden.

Let it drink deep in thy most vital part;  
Strike home, and do me *reason* in thy heart. Id.  
Chaucer makes Arcite violent in his love, and un-  
just in the pursuit of it; yet when he came to die,  
he made him think more *reasonably*. Id.

The papists ought in *reason* to allow them all the  
excuses they make use of for themselves; such as an  
invincible ignorance, oral tradition, and authority.  
Sittingfleet.

*Reason*, in the English language, sometimes is taken for true and clear principles; sometimes for clear and fair deductions; sometimes for the cause, particularly the final cause. *Locke.*

Every man's *reasoning* and knowledge is only about the ideas existing in his own mind; and our knowledge and *reasoning* about other things is only as they correspond with those our particular ideas. *Id.*

By *reason* of the sickness of a reverend prelate, I have been over-ruled to approach this place. *Sprat.*

If we commemorate any mystery of our redemption, or article of our faith, we ought to confirm our belief of it, by considering all those *reasons* upon which it is built; that we may be able to give a good account of the hope that is in us. *Nelson.*

When they are clearly discovered, well digested, and well *reasoned* in every part, there is beauty in such a theory. *Burnet.*

No man, in the strength of the first grace, can merit the second; for *reason* they do not, who think so; unless a beggar, by receiving one alms can merit another. *South.*

The most probable way of bringing France to *reason*, would be by the making an attempt upon the Spanish West Indies, and by that means to cut off all communication with this great source of riches. *Addison.*

Love is not to be *reasoned* down, or lost

In high ambition. *Id.*

The terms are loose and undefined; and what less becomes a fair *reasoner*, he puts wrong and invidious names to every thing to colour a false way of arguing. *Id.*

Due reverence pay  
To learned Epicurus; see the way  
By which this *reasoner* of so high renown  
Moves through the ecliptick road the rolling sun. *Blackmore.*

Your *reasonings* therefore on this head, amount to what the schools call *ignoratio elenchi*; proving before the question, or talking wide of the purpose. *Waterland.*

In the lonely grove,  
'Twas there just and good he *reasoned* strong,  
Cleared some great truth, or raised some serious song. *Tickel.*

It would be well, if people would not lay so much weight on their own *reason* in matters of religion, as to think every thing impossible and absurd which they cannot conceive: how often do we contradict the right rules of *reason* in the whole course of our lives! *reason* itself is true and just, but the *reason* of every particular man is weak and wavering, perpetually swayed and turned by his interests, his passions, and his vices. *Swift.*

A law may be *reasonable* in itself, although a man does not allow it, or does not know the *reason* of the lawgivers. *Id.*

The church has formerly had eminent saints in that sex; and it may *reasonably* be thought that it is purely owing to their poor and vain education, that this honour of their sex is for the most part confined to former ages. *Law.*

On the whole it appears, and my argument shows  
With a *reasoning* the court will never condemn.  
That the spectacles plainly were made for the nose.

And the nose was as plainly intended for them. *Couper.*

**REASON** is that faculty or power of the mind whereby it distinguishes good from evil, truth from falsehood.

**REASSEMBLE**, *v. a.* Re and assemble. To collect anew.

There *reassembling* our afflicted powers,  
Consult how to offend our enemy. *Milton.*

**REASSERT**, *v. a.* Re and assert. To assert anew; to maintain after suspension or cessation. His steps I followed, his doctrine I *reasserted*. *Atterbury.*

Young Orestes grown  
To manly years should *reassert* the throne. *Pope.*

**REASSUME**, *v. a.* Lat. *reassumo*; re and assume. To resume; to take again.

Nor only on the Trojans fell this doom,  
Their hearts at last the vanquished *reassume*. *Denham.*

To him the Son returned  
Into his blissful bosom *reassumed*,  
In glory as of old. *Milton.*

After Henry VIII. had *reassumed* the supremacy, a statute was made, by which all doctors of the civil law might be made chancellors. *Ayliffe.*

For this he *reassumes* the nod,  
While Semele commands the god. *Prior.*

**REASSURE**, *v. a.* Fr. *reassurer*; re and assure. To restore from terror; free from fear.

They rose with fear,  
Till dauntless Pallas *reassured* the rest. *Dryden.*

**REATE**, *n. s.* A kind of long small grass that grows in water, and complicates itself together.

Let them lie dry six months to kill the water-weeds; as water-lillies, candocks, *reate*, and bul-rushes. *Walton.*

**REAVE**, *v. a.* Pret. *ref.* Sax. *reafian*; Dan. *ræve*. To take away by stealth or violence. See **BEREAVE**.

Dismounting from his lofty steed,  
He to him leapt, in mind to *reave* his life. *Spenser.*

Who can be bound by any solemn vow  
To do a murderous deed, to rob a man,  
To force a spotless virgin's chastity,  
To *reave* the orphan of his patrimony,  
And have no other reason for his wrong  
But that he was bound by a solemn oath? *Shakespeare.*

But these men knowing, having heard the voice  
Of God, by some meanes, that sad death hath *ref*  
The ruler heere; will never suffer left  
Their unjust wooing of his wife. *Chapman.*

Some make his meashy bed, but *reave* his rest. *Curru.*

**REAUMUR** (Renatus Anthony Ferchault, sieur de), a celebrated French philosopher, born at Rochelle in 1683. After the usual course of school education, in the place of his birth, he began a course of philosophy at Poitiers, and of civil law at Bourges; but soon relinquished the latter, to apply himself to mathematics, physics, and natural history. He repaired to Paris in 1703, and was received into the Academy of Sciences in 1708. From that hour he was wholly employed in natural history. The numerous discoveries he made in the various branches of science are too numerous to detail. He discovered the Turquois mines in the late province of Languedoc; and his improvement on the art of converting iron into steel was rewarded by a pension of 12,000 livres. It was owing to his endeavours that there were es-

tablished in France manufactures of tin plates and of porcelain in imitation of china-ware. We owe to him also a new thermometer, which bears his name, and is pretty generally used on the continent. Reaumur's is a spirit thermometer, having the freezing point at 0°, and the boiling point at 80°. He died in the seventy-sixth year of his age, on the 18th of October, 1757. He bequeathed to the Academy of Sciences his MSS., and his collection of natural productions. His chief works are, a number of Memoirs and Observations on different parts of Natural History; printed in the collections of the Academy of Sciences. A large work printed separately in 6 vols. in 4to., entitled A Natural History of Insects; which is much esteemed.

REAUMURIA, in botany, a genus of the pentagynia order and pentandria class of plants; natural order thirteenth, succulentæ: CAL. hexaphyllous; petals five: CAPS. unilocular, quinquevalved, and polyspermous. Species two only, annuals of Syria.

REBAPTIZE', *v. a.* Fr. *rebaptiser*; re and baptize. To baptize again.

In maintenance of *rebaptization*, their arguments are built upon this, that heretics are not any part of the church of Christ.

Understanding that the rights of the church were observed, he approved of their baptism, and would not suffer them to be *rebaptized*.

REBATE', *v. n.* Fr. *rebatre*. To blunt; beat to obtuseness.

He doth *rebate* and blunt his natural edge  
With profits of the mind, steady and fast.

The icy goat, the crab which square the scales;  
With those of aries trine consent to hate  
The scales of libra, and her rays *rebate*.

My flagging soul flies under her own pitch,  
My senses, too, are dull and stupified,  
Their edge *rebated*.

Their innocence unfeigned long joys afford  
To the honest nuptial bed, and, in the wane  
Of life, *rebate* the miseries of age.

REBATE, or REBATEMENT, in commerce, a term much used at Amsterdam, for discount allowed on the price of several commodities, when the buyer, instead of taking time, advances ready money.

REBEC, or REBECK, a Moorish word signifying an instrument with two strings played on with a bow. The Moors first brought the rebec into Spain, whence it passed into Italy, and, after the addition of a third string, obtained the name of rebecca; whence the old English rebec, or fiddle with three strings.

Rebec, ribibe, and ribible seem to be different names of the same instrument, and are often indiscriminately used by Gower, Chaucer, and the more ancient bards.

As the head, or scroll-work, of old viols and violins used to be curiously carved, so seems to have been that of the rebec. Chaucer compares the face of an old woman, an old trot, to the head of a rebec. See the example above.

REBECK, *n. s.* Fr. *rebec*; Ital. *ribecca*. A three-stringed fiddle.

Brother, quod he, here wonneth an old *rebeke*,  
That had almost as lefe to lese her nekke  
As for to geve a peny of hire good.

Chaucer. *Cant. Tales*.

When the merry bells ring round,  
And the jocund *rebecks* sound,  
To many a youth and many a maid,  
Dancing in the checkered shade.

Milton.

REBEL', *n. s. & v. n.* Fr. *rebelle*; Lat. *REBEL'LI'ON, n. s.* } *rebellis*. A revolter;  
REBEL'LI'OUS, *adj.* } one who opposes law-  
REBEL'LI'OUSLY, *adv.* } ful authority: to act  
REBEL'LI'OUSNESS, *n. s.* } in opposition to such  
authority: rebellion is the revolt or insurrection  
made: rebellious means opposed to lawful authority: the adverb and noun substantive corresponding.

From the day that thou didst depart out of Egypt,  
until ye came unto this place, ye have been *rebellious*  
against the Lord.

Deut. ix. 7.

This our son is stubborn and *rebellious*, he will  
not obey our voice.

Id. xxi. 20.

The merciless Macdonel  
Worthy to be a *rebel*; for to that  
The multiplying villainies of nature  
Do swarm upon him.

Shakspeare. *Macbeth*.

Boys, immature in knowledge,  
Pawn their experience to the present pleasure,  
And so *rebel* to judgment.

Shakspeare.

Such smiling rogues as these soothe every passion,  
That in the nature of their lords *rebels*;

Bring oil to fire.

Id. *King Lear*.

He was victorious in *rebellions* and seditious of  
people.

Bacon.

Where one shewed him where a nobleman, that  
had *rebelliously* borne arms against him, lay very  
honorably intombed, and advised the king to deface  
the monument; he said, no, no, but I would all the  
rest of mine enemies were as honourably intombed.

Camden.

Who could ever yet shew me a man *rebelliously*  
undutiful to his parents that hath prospered in him-  
self, and his seed?

Bp. Hall.

Armed with thy might, rid heaven of these *rebelled*.  
Milton.

Of their names in heavenly records now  
Is no memorial, blotted out and razed  
By their *rebellion* from the books of life.

Id.

Bent he seems  
On desperate revenge, which shall redound  
Upon his own *rebellious* head.

Id.

How could my hand *rebel* against my heart?  
How could your heart *rebel* against your reason?

Dryden.

Part of the angels *rebelled* against God, and  
thereby lost their happy state.

Locke.

Thou, with *rebel* insolence, didst dare  
To own and to protect that hoary ruffian;  
And, in despite even of thy father's justice,  
To stir the factious rabble up to arms.

Rowe.

This is not disobedience but *rebellion*; 'tis dis-  
claiming the sovereignty of Christ, and renouncing  
all allegiance to his authority.

Rogers.

Shall man from nature's sanction stray,  
A *rebel* to her rightful sway?

Felton.

REBELLION (rebellio), among the Romans, was where those who had been formerly overcome in battle, and yielded to their subjection, made a second resistance; but with us it is generally used for taking up arms traitorously against the king, whether by natural subjects, or others when once subdued; and the word rebel is sometimes applied to him who wilfully breaks a law. There is a difference between enemies and rebels. Enemies are those who are out of the king's allegiance: therefore subjects of the king, either in open war, or rebellion, are not the

king's enemies, but traitors. And David, prince of Wales, who levied war against Edward I., because he was said to be within the allegiance of the king, had sentence pronounced against him as a traitor and rebel. Private persons may arm themselves to suppress rebels, enemies, &c.

**REBELLIOUS ASSEMBLY** is a gathering together of twelve persons or more, intending unlawfully, of their own authority, to attempt any change in the law or statutes of the realm; or to destroy the enclosures of any ground, or banks of any fish pond, pool, or conduit, to the intent the same shall lie waste and void; or to destroy the deer in any park, or any warren of conies, dove-houses, or fish in ponds; or any house, barns, mills, or bays; or to burn stacks of corn; or abate rents, or prices of victuals, &c.

**REBELLOW**, *v. n.* Re and bellow. To bellow in return; echo back a loud noise.

He loudly brayed with beastly yelling sound,  
That all the fields *rebellowed* again. *Spenser.*  
The resisting air the thunder broke,  
The cave *rebellowed*, and the temple shook. *Dryden.*  
From whence were heard, *rebellowing* to the main,  
The roars of lions. *Id. Æneis.*

**REBOUND**, *v. n. v. a. & n. s.* Fr. *rebondir*. Re and bound. To spring back; be reverberated; fly back in consequence of motion impressed and resisted by a greater power; reverberate: a reverberation.

Whether it were a roaring voice of most savage wild beasts, or a *rebouncing* echo from the hollow mountains. *Wisdom xvii.*

I do feel,  
By the *rebound* of yours, a grief that shoots  
My very heart. *Shakspeare. Antony and Cleopatra.*  
If you strike a ball sidelong, not full upon the surface, the *rebound* will be as much the contrary way; whether there be any such resilience in echoes may be tried. *Bacon.*

It with *rebouncing* surge the bars assailed. *Milton.*  
All our invectives at their supposed errors fall back with a *rebounced* force upon our own real ones. *Decay of Piety.*

Silenus sung, the vales his voice *rebound*,  
And carry to the skies the sacred sound. *Dryden.*  
The weapon with unerring fury flew,  
At his left shoulder aimed: nor entrance found;  
But back, as from a rock, with swift *rebound*  
Harmless returned. *Id.*

Life and death are in the power of the tongue, and that not only directly with regard to the good or ill we may do to others, but reflexively with regard to what may *rebound* to ourselves. *Government of the Tongue.*

Flowers, by the soft South West  
Opened, and gathered by religious hands,  
*Rebound* their sweets from the odoriferous pavement. *Prior.*

Bodies which are absolutely hard, or so soft as to be void of elasticity, will not *rebound* from one another: impenetrability makes them only stop. *Newton's Opticks.*

She bounding from the shelfy shore,  
Round the descending nymph the waves *rebouncing*  
roar. *Pope.*

**REBUFF**, *n. s.* Fr. *rebuffade*, Ital. *rebuffo*. Repercussion; quick and sudden resistance.

By ill chance  
The strong *rebuff* of some tumultuous cloud,  
Instinct with fire and nitre, hurried him  
As many miles aloft. *Milton's Paradise Lost.*

**REBUILD**, *v. a.* Re and build. To re-edify; restore from demolition; repair.

The fines imposed there were the more questioned and repined against, because they were assigned to the *rebuilding* and repairing of St. Paul's church. *Clarendon.*

Fine is the secret, delicate the art,  
To raise the shades of heroes to our view,  
*Rebuild* fallen empires, and old time renew. *Tichel.*

**REBUKE**, *v. a. & n. s.* } Fr. *reboucher*, or  
**REBUKABLE**, *adj.* } Lat. *repungo*. To  
chide; reprehend; repress; censure: the ce-  
sure given: rebukable is worthy of rebuke.

Thy *rebuke* hath broken my heart. *Psalm lix.*  
The revolvers are profound to make slaughter,  
though I have been a *rebuker* of them all. *Hæc.*  
He was *rebuked* for his iniquity; the dumb ass,  
speaking with man's voice, forbad the madness of the prophet. *2 Peter.*

Why bear you these *rebukes*, and answer not? *Shakspeare.*  
I am ashamed; does not the stone *rebuke* me,  
For being more stone than it? *Id.*

*Rebukable*  
And worthy shameful check it were, to stand  
On mere mechanick compliment. *Id.*  
The proud he tamed, the penitent he cheered,  
Nor to *rebuke* the rich offender feared. *Dryden.*  
He gave him so terrible a *rebuke* upon the fore-  
head with his heel, that he laid him at his length. *L'Estrange.*

The *rebukes* and chiding to children, should be in grave and dispassionate words. *Locke.*

Shall Cibber's son, without *rebuke*,  
Swear like a lord? *Pope.*  
Should vice expect to escape *rebuke*,  
Because its owner is a duke? *Swift's Miscellanies.*

**REBUS**, *n. s.* Lat. *rebus*. A word represented by a picture.

Some citizens, wanting arms, have coined themselves certain devices alluding to their names, which we call *rebuses*; Master Jugg the *printer*, in many of his books, took, to express his name, a nightgale sitting in a bush with a scrole in her mouth, wherein was written juggle, juggle, juggle. *Peacham.*

The origin of the **REBUS** or name-device, as Camden styles it, is generally attributed to the priests of Picardy, who, it seems, anciently used to make certain libels, entitled de rebus quæ geruntur, being satires on the transactions and manners of the day; in which they made great use of these allusions, omitting and breaking words and supplying them with paintings. Camden tells us, the rebus was in great esteem among our forefathers; and that he was nobody who could not hammer out of his name an invention by this wit-craft, and picture it accordingly.

The Sieur des Accords has made an ample collection of the most famous rebuses de Picardie, and Camden has done something of the same kind in his Remains. Abel Druggier's device in Ben Jonson's Alchemist, and Jack of Newbury, in the Spectator, are known to every body. But the rebus, being once raised to signposts, grew out of fashion at court.

This fancy for representing the name by some device seems to have existed in the pure Augustan age: Cicero in a dedication to the gods, inscribed Marcus Tullius, with a little pea,

called by the Latins cicer, by us a chich pea. And Julius Cæsar, on some of his coins, used an elephant, called Cæsar in the Mauritanian tongue.

**REBUS**, in heraldry, a coat of arms which bears an allusion to the name of the person; as three castles, for Castleton; three cups for Butler; three conies, for Conijoy; bearings which are of great antiquity.

**REBUT**, *s. n.* *Fr. rebuter.* To retire back. Obsolete.

Themselves too rudely rigorous,  
Astonied with the stroke of their own hand,  
Do back *rebut*, and each to other yielded land.

*Spenser.*

**REBUTTER** (from the French *bouter*, to put back or bar) is the answer of defendant to plaintiff's surrejoinder; and plaintiff's answer to the rebutter is called a surrebutter. Rebutter is also where a man by deed or fine grants to warrant any land or hereditament to another; and the person making the warranty, or his heir, sues him to whom the warranty is made, or his heir or assignee, for the same thing; if he who is so sued plead the deed or fine with warranty, and pray judgment, if the plaintiff shall be received to demand the thing which he ought to warrant to the party against the warranty in the deed, &c., this is called a rebutter. And if I grant to a tenant to hold without impeachment of waste, and afterwards implead him for waste done, he may debar me of this action by showing my grant which is a rebutter.

**RECAL**, *v. a. & n. s.* Re and call. To call back; call again; revoke: revocation.

They who *recall* the church unto that which was at the first, must set bounds unto their speeches.

*Hooker.*

If Henry were *recalled* to life again,  
These news would cause him once more yield the ghost.

*Shakspeare.*

Other decrees  
Against thee are gone forth, without *recall*.

*Milton.*

'Tis done, and since 'tis done 'tis past *recall*;  
And, since 'tis past *recall*, must be forgotten.

*Dryden.*

Neglected long, she let the secret rest,  
Till love *recalled* it to her lab'ring breast. *Id.*  
It is strange the soul should never once *recall* over any of its pure native ideas, before it borrowed any thing from the body; never any other ideas, but what derive their original from that union. *Locks.*

To the churches, wherein they were ordained, they might of right be *recalled* as to their proper church, under pain of excommunication. *Ayliffe.*

If princes, whose dominions lie contiguous, be forced to draw from those armies which act against France, we must hourly expect having those troops *recalled* which they now leave with us in the midst of a siege. *Swift.*

It is necessary to *recall* to the reader's mind, the desire Ulysses has to reach his own country.

*Broom's Odyssey.*

**RECANATI**, the ancient Recinetum, a town of Italy, in the Ecclesiastical States, and delegation of Ancona. It is finely situated on an eminence near the Musone, four miles south-west of Loretto, and forms with that town the see of a bishop. Its only objects of interest are a monument in bronze, at the town-house, and an aque-

duct leading to Loretto. The country around is extremely fertile. Inhabitants 4000. Four miles south-west of Loretto, and thirteen south of Ancona.

**RECAN'T**, *v. a. & v. n.* } *Lat. recanto.* To  
**RECAN'TATION**, *n. s.* } retract; recall; con-  
**RECAN'TER**. } tradict; revoke a position: recantation and recanter corresponding. She could not see means to join this *recantation* to the former vow. *Sidney.*

He shall do this, or else I do *recant*  
The pardon that I late pronounced. *Shakspeare.*

The publick body, which doth seldom

Play the *recanter*, feeling in itself

A lack of Timon's aid, hath sense withal  
Of its own fall, restraining aid to Timon. *Id.*

How soon would ease *recant*

Vows made in pain as violent and void! *Milton.*  
The poor man was imprisoned for this discovery, and forced to make a publick *recantation*.

*Sillingfleet.*

If it be thought that the praise of a translation consists in adding new beauties, I shall be willing to *recant*.

*Dryden.*

That the legislature should have power to change the succession, whenever the necessities of the kingdom require, is so useful towards preserving our religion and liberty that I know not how to *recant*.

*Swift.*

**RECAPITULATE**, *v. a.* } *Fr. recapituler.*  
**RECAPITULATION**, *n. s.* } *Lat. re and capitulum.* To repeat  
**RECAPITULATORY**, *adj.* } again; the repetition made; repeating again.

He maketh a *recapitulation* of the christian churches; among the rest he addeth the isle of Eden by name.

*Raleigh.*

Hylobares judiciously and resentingly *recapitulates* your main reasonings. *More's Divine Dialogues.*

I have been forced to *recapitulate* these things, because mankind is not more liable to deceit, than it is willing to continue in a pleasing error.

*Dryden.*

Instead of raising any particular uses from the point that has been delivered, let us make a brief *recapitulation* of the whole.

*South.*

*Recapitulatory* exercises.

*Garretson.*

**RECAR'RY**, *v. a.* Re and carry. To carry back.

When the Turks besieged Malta or Rhodes, pigeons carried and *recarried* letters. *Walton.*

**RECCO**, a town of the Sardinian States, in the province of Genoa, on the sea coast. Inhabitants 2000. It carries on some traffic in linen; likewise in oil fruit, and other products of the country. Ten miles E. S. E. of Genoa.

**RECEDE'**, *v. n.* *Lat. recedo.* To fall back; retreat; desist.

I can be content to *recede* much from my own interests and personal rights. *King Charles.*

They hoped that their general assembly would be persuaded to depart from some of their demands; but that, for the present, they had not authority to *recede* from any one proposition. *Clarendon.*

A deaf noise of sounds that never cease,  
Confused and chiding, like the hollow roar  
Of tides *receding* from the insulted shore.

*Dryden.*

Ye doubts and fears!

Scattered by winds, *recede*, and wild in forests rove

*Prior.*

All bodies, moved circularly, have a perpetual endeavour to *recede* from the centre, and every



moment would fly out in right lines, if they were not violently restrained by contiguous matter.

*Bentley.*

RECEIVE, *v. a.* } Fr. *recevoir*; Lat. *re-*  
RECEIPT, *n. s.* } *cipio*. To obtain or take  
RECEIVEDNESS, } that which is due; take or  
RECEIVER. } obtain in any sense or  
way; embrace; admit; entertain: receipt is the  
act of receiving; reception; admission; wel-  
come; note of something received or to be  
taken, hence a medical or other prescription;  
place of receiving: receivedness is general al-  
lowance; custom: receiver follows all the senses  
of receive.

Let her be shut out from the camp seven days, and  
after that *received* in again. *Numbers* xii. 14.

What! shall we receive good at the hand of God,  
and shall we not *receive* evil? *Job* ii. 10.

Thou shalt guide me with thy counsel, and after-  
ward *receive* me to glory. *Psalms* lxxiii. 24.

Jesus saw Matthew sitting at the *receipt* of custom.

*Matthew.*

A certain nobleman went into a far country, to  
*receive* for himself a kingdom, and return. *Luke.*

He that doeth wrong, shall *receive* for the wrong  
done; and there is no respect of persons. *Colossians.*

The same words in my lady Philoclea's mouth  
might have had a better grace, and perchance have  
found a gentler *receipt*. *Sidney.*

This is a great cause of the maintenance of thieves,  
knowing their *receivers* always ready; for were there  
no *receivers*, there would be no thieves.

*Spenser's State of Ireland.*

It is of things heavenly an universal declaration,  
working in them, whose hearts God inspirith with the  
due consideration thereof, a habit or disposition of  
mind whereby they are made fit vessels, both for the  
*receipt* and delivery of whatsoever spiritual perfection.

*Hooker.*

Long *received* custom forbidding them to do as  
they did, there was no excuse to justify their act;  
unless in the scripture, they could show some law  
that did licence them thus to break a *received* custom.

*Id.*

Villain, thou did'st deny the gold's *receipt*,  
And told me of a mistress.

*Shakespeare. Comedy of Errors.*

On's bed of death  
Many *receipts* he gave me, chiefly one  
Of his old experience the only darling.

*Shakespeare.*

If by this crime he owes the law his life,  
Why, let the war *receive* it in valiant gore. *Id.*

To one of your *receiving*,

*Id.*

All the learnings that his time could make him *re-*  
*ceive* of, he took as we do air. *Id.*

Lest any should think that any thing in this num-  
ber eight creates the diapason; this computation of  
eight is rather a thing *receiv'd*, than any true com-  
putation. *Bacon.*

There is a *receiver*, who alone handleth the mo-  
nies. *Id.*

She from whose influence all impression came,  
But by *receivers'* impotencies lame. *Donne.*

*Jove* requite,

And all the immortal gods, with that delight  
Thou most desirest, thy kind *receite* of me;  
Of friend to humane hospitality. *Chapman.*

What was so mercifully designed, might have been  
improved by the humble and diligent *receivers* unto  
their greatest advantages. *Hammond.*

I'll teach him a *receipt* to make  
Words that weep, and tears that speak. *Cowley.*

The signification and sense of the sacrament dis-  
pose the spirit of the *receiver* to admit the grace of the  
spirit of God there consigned. *Taylor.*

Abundance fit to honour, and *receive*  
Our heavenly stranger. *Milton.*

That Medea could make old men young again, was  
nothing else, but that, from a knowledge of simples,  
she had a *receipt* to make white hair black.

*Broune's Vulgar Errors.*

Others will, upon account of the *receivedness* of the  
proposed opinion, think it rather worth to be ex-  
amined, than acquiesced in. *Boule.*

The joy of a monarch for the news of a victory  
must not be expressed like the ecstasy of a harle-  
quin, on the *receipt* of a letter from his mistress.

*Dryden.*

Wise leeches will not vain *receipts* obtrude,  
While growing pains pronounce the humours crude.

*Id.*

They lived with the friendship and equality of  
brethren; *received* no laws from one another, but  
lived separately. *Locke.*

The idea of solidity we *receive* by our touch. *Id.*

If one third of the money in trade were locked up,  
land-holders must *receive* one third less for their  
goods; a less quantity of money by one third being  
to be distributed amongst an equal number of *re-*  
*ceivers*. *Id.*

In all works of liberality, something more is to be  
considered, besides the occasion of the givers; and  
that is the occasion of the *receivers*. *Sprat.*

Gratitude is a virtue, disposing the mind to an  
inward sense, and an outward acknowledgement  
of a benefit *received*, together with a readiness to re-  
turn the same, as the occasions of the doer shall re-  
quire, and the abilities of the *receiver* extend to.

*Smith.*

These liquors which the wide *receiver* fill,  
Prepared with labour and refined with skill,  
Another course to distant parts begin. *Blackmore.*

Alkaline spirits run in veins down the sides of the  
*receiver* in distillations, which will not take fire.

*Arbutnot.*

Scribonius found the *receipt* in a letter wrote to Ti-  
berius, and was never able to procure the *receipt*  
during the emperor's life. *Id. on Coins.*

It must be done upon the *receipt* of the wound,  
before the patient's spirits be overheated. *Wiseman.*

The air that in exhausted *receivers* of air-pumps  
is exhaled from minerals, is as true as to elasticity  
and density of rarefaction, as that we respire in.

*Bentley.*

Some dryly plain, without invention's aid,  
Write dull *receipts* how poems may be made. *Pope.*

Wood's halfpence will be offered for six a penny,  
and the necessary *receivers* will be losers of two-thirds  
in their pay. *Suiff.*

Free converse with persons of different sects will  
enlarge our charity towards others, and incline us to  
*receive* them into all the degrees of unity and affec-  
tion, which the word of God requires. *Watts.*

RECEIPT, or RECEIT, in commerce, an acquit-  
tance or discharge, in writing, intimating that  
the party has received a certain sum of money,  
either in full for the whole debt, or in part,  
or on account. Receipts are subject to stamp  
duties.

RECEIVER, receptor or receptator, in law, is  
commonly used in a bad sense for such as know-  
ingly receive stolen goods from thieves, and con-  
ceal them. This crime is felony, and the punish-  
ment is transportation for fourteen years.

RECEIVERS, in chemistry, are vessels adapted  
to the necks or beaks of retorts, alembics, and

other distillatory vessels, to collect and contain the products of the distillation. They are made of glass, earthenware, and of metal. See LABORATORY.

**RECELEBRATE**, *v. a.* Re and celebrate. To celebrate anew.

French air and English verso here wedded lie :  
Who did this knot compose,  
Again hath brought the lily to the rose ;  
And with their chained dance  
*Recelebrates* the joyful match. *Ben Jonson.*

**RECENSIO** was an account taken by the censors, every lustrum, of all the Roman people. It was a general survey, at which the equites, as well as the rest of the people, were to appear. New names were put upon the censor's list, and old ones cancelled. In short, it was a more solemn and accurate sort of probatio, showing who were fit for military service.

**RECENSION**, *n. s.* Lat. *recensio*. Enumeration ; review.

In this *recension* of monthly flowers, it is to be understood from its first appearing to its final withering.

**RECENT**, *adj.* } Lat. *recens*. New ; not  
**RECENTLY**, *adv.* } of long existence : the  
**RECENTNESS**, *n. s.* } adverb and noun-substantive corresponding.

Among all the great and worthy persons, whereof the memory remaineth, either ancient or recent, there is not one that hath been transported to the mad degree of love. *Bacon.*

This inference of the *recentness* of mankind from the *recentness* of these apotheoses of gentile deities, seems too weak to bear up this supposition of the novitas humani generis. *Hale.*

The ancients were of opinion, that those parts, where Egypt now is, were formerly sea, and that a considerable portion of that country was recent, and formed out of the mud discharged into the neighbouring sea by the Nile. *Woodward.*

Those tubes which are most recently made of fluids are most flexible and most easily lengthened. *Arbuthnot.*

A schirrus in its *recency*, whilst it is in its augment, requireth milder applications than the confirmed one. *Wiseman.*

Ulysses moves  
Urged on by want, and recent from the storms,  
The brackish ouze his manly grace deforms. *Pope.*

**RECEPTACLE**, *n. s.* Lat. *receptaculum*. A vessel or place into which any thing is received. This had formerly the accent on the first syllable.

The county of Tipperary, the only county palatine in Ireland, is by abuse of some bad ones made a *receptacle* to rob the rest of the counties about it. *Spenser's State of Ireland.*

When the sharpness of death was overcome, he then opened heaven as well to believing gentiles as Jews ; heaven till then was no *receptacle* to the souls of either. *Hooker.*

As in a vault, an ancient *receptacle*,  
Where for these many hundred years the bones  
Of all my buried ancestors are packt. *Shakspere.*

The eye of the soul, or *receptacle* of sapience, and divine knowledge.

*Raleigh's History of the World.*  
Let paradise a *receptacle* prove

To spirits foul, and all my trees their prey. *Milton.*

Their intelligence put in at the top of the horn, shall convey it into a little *receptacle* at the bottom. *Addison.*

Though the supply from this great *receptacle* below be continual and alike to all the globe ; yet when it arrives near the surface, where the heat is not so uniform, it is subject to vicissitudes. *Woodward.*

These are conveniences to private persons ; instead of being *receptacles* for the truly poor, they tempt men to pretend poverty, in order to share the advantages. *Aterbury.*

**RECEPTIBILITY**, *n. s.* } All of Latin  
**RECEPTARY**, } *receptus*. Possibi-  
**RECEPTION**, } lity of receiving ;  
**RECEPTIVE**, *adj.* } *receptory* is the  
**RECEPTORY**. } thing received  
(obsolete) : reception, the act or manner of receiving ; admission ; and, in an obsolete sense, recovering : receptive is having the quality of admission : *receptory*, generally or commonly received.

The soul being, as it is, active, perfected by love of that infinite good, shall, as it is *receptive*, be also perfected with those supernatural passions of joy, peace and delight. *Hooker.*

He was right glad of the French king's *reception* of those towns from Maximilian. *Bacon.*

This succession of so many powerful methods being farther prescribed by God, have found so discouraging a *reception* that nothing but the violence of storming or battery can pretend to prove successful. *Hammond's Fundamentals.*

Causes, according still  
To the *reception* of their matter, act ;  
Not to the extent of their own sphere. *Milton.*  
All hope is lost

Of my *reception* into grace. *Id. Paradise Lost.*  
The pretended first matter is capable of all forms, and the imaginary space is *receptive* of all bodies. *Glanville.*

The peripatetic matter is a pure unacted power ; and this conceiv'd vacuum a mere *receptibility*. *Id.*

In this animal are found parts official unto nutrition, which, were its alinent the empty *reception* of air, provisions had been superfluous. *Broune.*

Although therein be contained many excellent things, and verified upon his own experience, yet are there many also *receptory*, and will not endure the test. *Id.*

They, which behold the present state of things, cannot condemn our sober enquiries in the doubtful appurtenances of arts and *receptaries* of philosophy. *Id.*

To advance the spiritual concerns of all that could in any kind become *receptive* of the good he meant them, was his unlimited designment and endeavour. *Fell.*

Both serve completely for the *reception* and communication of learned knowledge. *Holder.*

In some animals, the avenues, provided by nature for the *reception* of sensations, are few, and the perception, they are received with, obscure and dull. *Locke.*

**RECEPTACULUM**, in botany, one of the seven parts of fructification, defined by Linné to be the base which connects or supports the other parts. See BOTANY.

**RECESS**, *n. s.* } Lat. *recessus*. Retire-  
**RECESSION**. } ment ; retreat ; secession ;  
departure ; place of retreat or concealment ; secret part or drawer, hence, perhaps, papers or memoranda deposited there : *recession* is the act of retreating.

On both sides they made rather a kind of *recess*, than a breach of treaty, and concluded upon a truce.

*Bacon.*

What tumults could not do, an army must; my *recess* hath given them confidence that I may be conquered.

*King Charles.*

I conceived this parliament would find work with convenient *recesses* for the first three years. *Id.*

This happy place, our sweet

*Recess*, and only consolation left. *Milton.*

The great seraphic lords and cherubim,

In close *recess*, and secret conclave sat. *Id.*

In the *recess* of the jury, they are to consider their evidence.

*Hale.*

We come into the world, and know not how; we live in it in a self-nescience, and go hence again, and are as ignorant of our *recess*.

*Glanville.*

Whatsoever sign the sun possessed, whose *recess* or vicinity defineth the quarters of the year, those of our seasons were actually existent.

*Broune.*

In their mysteries, and most secret *recesses*, and adyta of their religion, their heathen priests betrayed and led their votaries into all the most horrid unnatural sins.

*Hammond.*

The deep *recesses* of the grove he gained.

*Dryden.*

Good verse, *recess* and solitude requires;

And ease from cares, and undisturbed desires. *Id.*

In the imperial chamber, the proctors have a florin taxed and allowed them for every substantial *recess*.

*Ayliffe.*

Fair Thames she haunts, and ev'ry neighbour bring grove,

Sacred to soft *recess* and gentle love.

*Prior.*

Every scholar should acquaint himself with a superficial scheme of all the sciences, yet there is no necessity for every man of learning to enter into their difficulties and deep *recesses*.

*Watts.*

**RECHABITES**, among the ancient Jews, a kind of religious order instituted by Jonadab the son of Rechab, comprehending only his own family and posterity. Their founder prescribed them three things: first, not to drink any wine; not to build any houses, but to dwell in tents; not to sow corn or plant vines. The Rechabites observed these rules with great strictness, as appears from Jer. xxxv. 6, &c. Whence St. Jerome, in his thirteenth epistle to Paulinus, calls them monachi, monks. Jonadab, their founder, lived under Jehoash, king of Judah, contemporary with Jehu king of Israel: his father Rechab, from whom his posterity were denominated, descended from Raguel or Jethro, father-in-law to Moses, who was a Kenite; whence Kenite and Rechabite are used as synonymous in Scripture. Serrurius distinguishes the ancient Rechabites descended from, and instituted by, Jethro, from the Rechabites of Jonadab. The injunction of Jonadab laid no obligation on the other Kenites, nor on the other descendants of Jethro. Benjamin de Tudela declares that he found this celebrated family still existing in the neighbourhood of Mecca: and the recent publication of the Travels of Mr. Wolff in the East seems to confirm the fact of their present existence.

The Rechabites were mentioned to him under the name of Hybarri both by the Jews and Mahometans of Yemen: and making enquiry respecting them of some Jews whom he found leading an Arab life in the desert, one of them exclaimed, 'See there is one of them,' and turning his eyes, as directed, he saw a man standing by his horse's head dressed like an Arab, but having a far more striking countenance than this race

have generally. He accepted thankfully a bible in Arabic and Hebrew (reading both); but answered all questions 'in a voice of thunder.' When asked who he was, he read aloud the whole of the thirty-fifth chapter of Jeremiah, saying at the close 'I am a son of Rechab.' He invited the missionary to visit his tribe who live in three caves near Mecca, and amount to 60,000 in number, and requested him to bring more bibles with him. Like their fathers, they dwell in huts, and neither sow the fields nor plant vineyards. They are circumcised, and profess pure Judaism; having among them the books of the Pentateuch, Samuel, and Kings: as well as the greater and lesser prophets. They all speak Arabic and read Hebrew. They attacked, as they state, Mahomet, in the name of the law of Sinai, but were defeated; and have a tradition that he was poisoned by a girl of their tribe. The Jews of the neighbourhood are persuaded that these Beni Rechab are intended for their powerful succor on their return to Judea. The Arabs spoke of them with great respect, and as admirable horsemen: one of these always appearing suddenly before the Mahometan caravan on its arrival in the vicinity of Mecca, to receive an accustomed tribute, or its refusal. In either case he vanishes again like lightning; but in the latter as the certain omen of a storm of well appointed cavalry, which bursts with resistless force on the heads of the Moslems.

**RECHANGE**, *v. a.* Fr. *rechanger*. Re and change. To change again.

Those endued with foresight, work with facility; others are perpetually changing and *rechanging* their work.

*Dryden.*

**RECHARGE**, *v. a.* Fr. *recharger*. Re and charge. To accuse in return; attack anew.

The fault that we find with them is, that they overmuch abridge the church of her power in these things: whereupon they *recharge* us, as if in these things we gave the church a liberty which hath no limits or bounds.

*Hooker.*

They charge, *recharge*, and all along the sea They drive, and squander the huge Belgian fleet.

*Dryden.*

**RECHEAT**, *n. s.* Re and cheat. Among hunters, a lesson which the huntsman winds on the horn, when the hounds have lost their game, to call them back from pursuing a counterscent.

That a woman conceived me, I thank her; but that I will have a *recheat* wind in my forehead, or hang my bugle in an invisible baldrick, all women shall pardon me.

*Shakspeare.*

**RECHERCHE ARCHIPELAGO**, a cluster of islands, stretching about 126 miles in the south coast of New Holland, between 33° and 34° S. lat. They are almost all small, and many of them naked rocks: from the banks and shoals interspersed, the access to this part of New Holland is dangerous.

**RECIDIVATION**, *n. s.* Lat. *recidivare*. Backsliding; falling again.

Our renewed obedience is still more indispensably required, though mixed with much of weakness, frailties, *recidivations*, to make us capable of pardon.

*Hammond's Practical Catechism.*

**RECTIPE**, *n. s.* Lat. *recipe*. A medical prescription.

I should enjoin you travel; for absence doth in a kind remove the cause, and answers the physician's

first *recipe*, vomiting and purging; but this would be too harsh.

*Suckling.*

The' apothecary train is wholly blind,  
From files a random *recipe* they take,  
And many deaths of one prescription make.

*Dryden.*

**RECIPIENT**, *n. s.* Lat. *recipiens*. A receiver; that to which any thing is communicated.

The form of sound words, dissolved by chymical preparation, ceases to be nutritive; and, after all the labours of the alembick, leaves in the *recipient* a fretting corrosive.

*Decay of Piety.*

Though the images, or whatever else is the cause of sense, may be alike as from the object, yet may the representations be varied according to the nature of the *recipient*.

*Glanville*

**RECIPROCAL**, *adj.* Lat. *reciprocus*;  
**RECIPROCALLY**, *adv.* Fr. *reciproque*. Al-  
**RECIPROCALNESS**, *n. s.* ternate; acting in vi-  
**RECIPROCATATE**, *v. n.* cissitude; mutual:  
**RECIPROCA'TION**, *n. s.* interchangeable mutu-  
ally: the adverb and nouns substantive corre-  
sponding: to reciprocate is to act interchangeably  
or alternately: reciprocation, alternation; action  
interchanged.

His mind and place

Infecting one another *reciprocally*. *Shakspeare.*

Corruption is *reciprocal* to generation; and they two are as nature's two boundaries, and guides to life and death.

*Bacon.*

The *reciprocalness* of the injury ought to allay the displeasure at it.

*Decay of Piety.*

What if that light,

To the terrestrial moon be as a star,  
Enlightening her by day, as she by night,  
This earth? *reciprocat*, if land be there,  
Fields and inhabitants.

*Milton.*

That Aristotle drowned himself in Euripus, as despairing to resolve the cause of its *reciprocatum* or ebb and flow seven times a day, is generally believed.

*Browne.*

Make the bodies appear enlightened by the shadows which bound the sight, which cause it to repose for some space of time; and *reciprocally* the shadows may be made sensible by enlightening your ground.

*Dryden.*

One brawny smith the puffing bellows plies,  
And draws, and blows *reciprocating* air.

*Id.*

Where there's no hope of a *reciprocal* aid, there can be no reason for the mutual obligation.

*L'Estrange.*

Where the bottom of the sea is owze or sand, it is by the motion of the water, so far as the *reciprocatum* of the sea extends to the bottom, brought to a level.

*Ray.*

From whence the quick *reciprocating* breath,  
The lobe adhesive, and the sweat of death.

*Sevel.*

If the distance be about the hundredth part of an inch, the water will rise to the height of about an inch; and, if the distance be greater or less in any proportion, the height will be *reciprocally* proportional to the distance very nearly: for the attractive force of the glasses is the same, whether the distance between them be greater or less; and the weight of the water drawn up is the same, if the height of it be *reciprocally* proportional to the height of the glasses.

*Newton's Optica.*

According to the laws of motion, if the bulk and activity of aliment and medicines are in *reciprocal* proportion, the effect will be the same.

*Arbuthnot on Aliments.*

In *reciprocal* duties, the failure on one side justifies not a failure on the other.

*Clarissa.*

These two rules will render a definition *reciprocal*

with the thing defined; which, in the schools, signifies, that the definition may be used in the place of the thing defined.

*Watts.*

**RECIPROCAL**, in arithmetic, algebra, &c., is the quotient arising from the division of unity by any number or quantity. Thus the reciprocal

of 2 is  $\frac{1}{2}$ , of 3 is  $\frac{1}{3}$ , and of  $a$  is  $\frac{1}{a}$ . Hence the

reciprocal of a vulgar fraction may be found, by barely making the numerator and the denominator mutually change places: thus the reciprocal

of  $\frac{1}{2}$  is  $\frac{2}{1}$  or 2; of  $\frac{2}{3}$  is  $\frac{3}{2}$ ; of  $\frac{a}{b}$  is  $\frac{b}{a}$ , &c. Hence

also, any quantity being multiplied by its reciprocal, the product is always equal to unity or 1; so  $\frac{1}{2} \times 2 = 1$ , and  $\frac{2}{3} \times \frac{3}{2} = 1$ , and  $\frac{a}{b} \times \frac{b}{a} = \frac{ab}{ab} = 1$ .

**RECIPROCAL FIGURES**, in geometry, those which have the antecedents and consequents of the same ratio in both figures.

**RECIPROCAL PROPORTION**, in arithmetic, is when, in four numbers, the fourth is less than the second, by so much as the third is greater than the first; and vice versa.

**RECIPROCAL TERMS**, among logicians, are those which have the same signification; and consequently are convertible, or may be used for each other.

**RECITE**, *v. a. & n. s.* Fr. *reciter*; Lat.

**RECIT'AL**, *n. s.* *recito*. To rehearse;

**RECITATION**, repeat; enumerate:

**RECITATIVE**, or, narrative (obsolete):

**RECITATI'VO**, recital and recitation

**RECIT'ER**, mean rehearsal; nar-

ration; repetition: recitative, or recitativo, a chaunt; a tuneful pronunciation: reciter, he who recites or repeats.

If menaces of scripture fall upon men's persons: if they are but the *recitations* and descriptions of God's decreed wrath, and those decrees and that wrath have no respect to the actual sins of men; why should terrors restrain me from sin, when present advantage invites me to it?

*Hammond.*

The last are repetitions and *recitals* of the first.

*Denham.*

This added to all former *recites* or observations of ong-lived races, makes it easy to conclude, that health and long life are the blessings of the poor as well as rich.

*Temple.*

He used philosophical arguments and *recitations*.

*Id.*

He introduced the examples of moral virtue, writ in verse, and performed in *recitative* music.

*Dryden.*

This often sets him on empty boasts, and betrays him into vain fantastic *recitals* of his own performances.

*Addison.*

While Telephus's youthful charms,  
His rosy neck, and winding arms,  
With endless rapture you *recite*,  
And in the tender name delight.

*Id.*

To make the rough *recital* aptly chime,  
Or bring the seam of Gallia's loss to rhyme,  
Is mighty hard.

*Prior.*

By singing poets upheld on either hand,  
Then thus in plain *recitativo* spoke.

*Dunciad.*

The thoughts of gods let Granville's verse *recite*,  
And bring the scenes of opening fate to light.

*Pope.*

**RECITATIVE**, or **RECITATIVO**, in music, a species of harmonious recitation, forming the medium between air and rhetorical declamation and

in which the composer or performer, rejecting the rigorous rules of time, imitates the inflexions, accent, and emphasis, of natural speech.

RECITATIVE, so called because its true province lies in narration and recital, was first introduced at Rome, in the year 1660, by Signor Emilia del Cavaliere, and was so powerfully recommended by its effect as to be speedily adopted in other parts of Italy, and, by degrees, through the rest of Europe. The beauty of this species of composition depends greatly on the character of the language in which it is used; as that is more or less accented and melodious, so the more or less natural and striking will be the effect of the recitative.

RECK, *v. n.* & *v. a.* } Sax. *reccan*; Swed. RECK'LESS, *adj.* } *reka*; Goth. *rekkia*. To RECK'LESSNESS, *n. s.* } value; care; heed; mind; care for: reckless is, careless; heedless: the noun substantive corresponding.

This son of mine, not *recking* danger, and neglecting the present good way he was in of doing himself good, came hither to do this kind office to my unspeakable grief. *Sidney.*

It made the king as *reckless* as them diligent. *Id.*  
Over many good fortunes began to breed a proud *recklessness* in them. *Id.*

Thou'st but a lazy loarde,  
And *recks* much of thy swinke,  
That with fond terms and witless words,  
To blear mine eyes dost think. *Spenser.*  
I *reck* as little what betideth me,  
As much I wish all good befortune you. *Shakespeare.*

Do not you as ungracious parsons do,  
Who shew the steep and thorny way to heaven;  
Yet like unthinking *reckless* libertine,  
That in the soft path of dalliance treads,  
*Recks* not his own rede. *Id.*  
Next this was drawn the *reckless* cities flame,  
When a strange hell poured down from heaven there came. *Cowley.*

With that care lost  
Went all his fear; of God, or hell, or worse,  
He *recked* not. *Milton.*  
Of night or loneliness it *recks* me not;  
I fear the dread events that dog them both,  
Lest some ill-greeting touch attempt the person  
Of our unowned sister. *Id.*

RECK'ON, *v. a.* & *v. n.* } Saxon *reccan*;  
RECK'ONER, *n. s.* } Belg. *reccenan*;  
RECK'ONING. } Teut. *reccen*. See  
RECK. To estimate as to value; number; count; esteem; assign in reckoning; to compute; calculate; charge to, or in account; taking *on, upon,* and *with*: a reckoner is a computer or calculator: reckoning, computation; account taken; esteem; estimate.

The priest shall *reckon* unto him the money according to the years that remain, and it shall be abated. *Leviticus xxvii. 18.*

There was no *reckoning* made with them of the money delivered into their hand. *2 Kings.*

To him that worketh is the reward not *reckoned* of grace, but of debt. *Romans iv. 4.*

Canst thou their *reck'nings* keep? the time compute  
When their swoln bellies shall enlarge their fruit! *Sandus.*

Where we cannot be persuaded that the will of God is, we should so far reject the authority of men, as to *reckon* it nothing. *Hooker.*

We shall not spend a large expence of time,  
Before we *reckon* with your several loves,  
And make us even with you. *Shakespeare.*  
His industry is up stairs and down; his eloquence  
the parcel of a *reckoning*. *Id. Henry IV.*  
*Reckoners* without their host must *reckon* twice. *Camden.*

I call posterity  
Into the debt, and *reckon* on her head. *Ben Jonson.*  
Varro's aviary is still so famous that it is *reckoned*  
for one of those notables which men of foreign na-  
tions record. *Wotton.*

Numb'ring of his virtues praise,  
Death lost the *reckoning* of his days. *Crashaw.*  
For him I *reckon* not in high estate;  
But thee, whose strength, while virtue was her mate,  
Might have subdued the earth. *Milton's Agonistes.*

God suffers the most grievous sins of particular persons to go unpunished in this world, because his justice will have another opportunity to meet and *reckon* with them. *Tillotson.*

You *reckon upon* losing your friends' kindness, when you have sufficiently convinced them, they can never hope for any of yours. *Temple's Miscellanies.*

The freezing of water, or the blowing of a plant, returning at equidistant periods, would as well serve men to *reckon* their years by, as the motions of the sun. *Locke.*

I *reckoned* above two hundred and fifty on the outside of the church, though I only told three sides of it. *Addison.*

A multitude of cities are *reckoned* up by the geographers, particularly by Ptolemy. *Arbuthnot.*

RECKONING, or a SHIP'S RECKONING, in navigation, is that account whereby at any time it may be known where the ship is, and on what course or courses she is to steer in order to gain her port; and that account taken from the log-board is called the dead reckoning. See NAVIGATION.

RECLAIM', *v. a.* } Lat. *reclamo*. To re- RECLAIM'ER, *n. s.* } form; correct; adjust; bring to a desired standard; tame: reclaimer is a contradicter.

He spared not the heads of any mischievous practices, but shewed sharp judgment on them for example sake, that all the meaner sort, which were infected with that evil, might, by terror thereof, be *reclaimed* and saved. *Spenser.*

This error whosoever is able to *reclaim*, he shall save more in one summer, than Themison destroyed in any autumn. *Broune.*

*Reclaim* your wife from strolling up and down  
To all assizes. *Dryden's Juvenal.*

The head-strong horses hurried Octavius, the trembling charioteer, along, and were deaf to his *reclaiming* them. *Dryden.*

Upon his fist he bore  
An eagle well *reclaimed*. *Id. Knight's Tale.*  
Are not hawks brought to the hand, and lions,  
tygers, and bears *reclaimed* by good usage? *L'Estrange.*

Minds she the dangers of the Lycian coast?  
Or is her tow'ring flight *reclaimed*,  
By seas from Icarus's downfal named?  
Vain is the call, and useless the advice. *Prior.*  
'Tis the intention of providence, in all the various expressions of his goodness, to *reclaim* mankind, and to engage their obedience. *Rogers's Sermons.*

Oh tyrant love!  
Wisdom and wit in vain *reclaim*,  
And arts but soften us to feel thy flame. *Pope.*

The penal laws in being against papists have been found ineffectual, and rather confirm than *reclaim* men from their errors. *Swift.*

**RECLAIMING**, in ancient English customs, was a lord's pursuing, prosecuting, and recalling his vassal, who had gone to live in another place without his permission.

**RECLAIMING** is also used for the demanding of a person or thing, to be delivered up to the prince or state to which it properly belongs; when, by any irregular means, it is come into another's possession.

**RECLAIMING**, in falconry, is taming a hawk, &c., and making her gentle and familiar. A partridge is said to reclaim, when she calls her young ones together, upon their scattering too much from her.

**RECLINE'**, *v. a., v. n. & adj.* Fr. *recliner*; Lat. *reclino*. To lean back, or sidewise; rest; repose: in a resting posture.

They sat *reclined*  
On the soft downy bank, damasked with flow'rs. *Milton.*

The mother  
*Reclined* her dying head upon his breast. *Dryden.*  
While thus she rested, on her arm *reclined*,  
The purling streams that through the meadows  
strayed,  
In drowsy murmurs lulled the gentle maid. *Addison.*

**RECLOSE'**, *v. a.* Re and close. To close again.

The silver ring she pulled, the door *reclosed*;  
The bolt, obedient to the silken cord,  
To the strong staple's inmost depth restored,  
Secured the valves. *Pope's Odyssey.*

**RECLUDE'**, *v. a.* Lat. *recludo*. To open. The ingredients absorb the intestinal superfluities, *reclude* opipulations, and mundify the blood. *Harvey.*

**RECLUSE'**, *adj. & n. s.* Fr. *reclus*; Lat. *reclusus*. Retired; shut up; a retired person.

This must be the inference of a mere contemplative; a *recluse* that converses only with his own meditations. *Decay of Piety.*

It seems you have not lived with an obstinate *recluse* from the disputes and transactions of men. *Hammond.*

I all the live-long day  
Consume in meditation deep, *recluse*,  
From human converse. *Philips.*

The nymphs  
Melissan, sacred and *recluse* to Ceres,  
Pour streams select, and purity of waters. *Prior.*

A **RECLUSE**, among the Roman Catholics, is a person shut up in a small cell of a hermitage or monastery, and cut off, not only from all conversation with the world, but even with the house. This is a kind of voluntary imprisonment, from a motive either of devotion or penance. The word is also applied to incontinent wives, whom their husbands procure to be thus kept in perpetual imprisonment in some religious house. Recluses were anciently very numerous. They took an oath never to stir out of their retreat; and, having entered it, the bishop set his seal upon the door; and the recluse had every thing necessary for the support of life conveyed through a window. If he was a priest, he was allowed a small oratory with a window, which looked into the church, through

which he might make his offerings at the mass, hear the singing, and answer those who spoke to him; but this window had curtains before it, so that he could not be seen. He was allowed a little garden, adjoining to his cell, in which he might plant a few herbs, and breathe a little fresh air. If he had disciples, their cells were contiguous to his, with only a window of communication, through which they conveyed necessities to him, and received his instructions. If a recluse fell sick, his door might be opened for persons to come in and assist him, but he himself was not to stir out.

**RECOAGULATION**, *n. s.* Re and coagulation. Second coagulation.

This salt, dissolved in a convenient quantity of water, does upon its *recoagulation* dispose of the aqueous particles among its own saline ones, and shoot into crystals. *Boyle.*

**REC'OGNIZE**, *v. a.* Lat. *recognosco*. To  
**REC'OGNISANCE**, *n. s.* } acknowledge; recover  
**RECOGNISEE'**, } or avow knowledge;  
**RECOGNISOR**, } review: recognisance  
**RECOGNITION**, } is, acknowledgment;  
badge; a legal bond described below: the  
recognisee is he in whose favor it is drawn; the  
recognisor, he who gives it: recognition is, acknowledgment; review.

Apparent it is, that all men are either christians or not; if by external profession they be christians, then are they of the visible church of Christ, and christians by external profession they are all whose mark of *recognizance* hath in it those things mentioned, yet although they be impious idolaters and wicked hereticks. *Hooker.*

She did gratify his amorous works  
With that *recognizance* and pledge of love,  
Which I first gave her; an handkerchief. *Shakspeare.*

The English should not marry with any Irish, unless bound by *recognizance* with sureties, to continue loyal. *Davies.*

The Israelites in Moses' days were redeemed out of Egypt; in memory and *recognition* whereof they were commanded to observe the weekly sabbath. *White.*

He brought several of them, even under their own hands, to *recognize* their sense of their undue procedure used by them unto him. *Fell.*

The British cannon formidably roars,  
While starting from his oozy bed,  
The asserted ocean rears his reverend head,  
To view and *recognize* his ancient lord. *Dryden.*  
Every species of fancy hath three modes: *recognition* of a thing, as present; memory of it, as past; and foresight of it, as to come. *Grew.*  
Christ will *recognize* them at a greater. *South.*

**RECOGNITION** is a term used in the English law books for the first chapter of the statute 1 Jac. I., by which the parliament acknowledged that, after the death of queen Elizabeth, the crown had rightfully descended to king James.

**RECOGNIZANCE**, in law, is an obligation of record, which a man enters into before some court of record or magistrate duly authorised, with condition to do some particular act; as to appear at the assizes, to keep the peace, to pay a debt, or the like. It is in most respects like another bond; the difference being chiefly this, that the bond is the creation of a fresh debt or obligation *de novo*, the recognizance is an acknowledgment of a former debt upon record;

the form whereof is, 'that A B doth acknowledge to owe to our lord the king, to the plaintiff, or to C D, or the like, the sum of £10,' with condition to be void on performance of the thing stipulated; in which case, the king, the plaintiff, C D, &c., is called the cognizee, is cui cognoscitur; as he that enters into the recognizance is called the cognizer, is cui cognoscit. This being certified to, or taken by, the officer of some court, is witnessed only by the record of that court, and not by the party's seal; so that it is not in strict propriety a deed, though the effects of it are greater than a common obligation; being allowed a priority in point of payment, and binding the lands of the cognizor from the time of enrolment on record.

RECOIL, *v. n. & n. s.* *Fr. reculer.* To rush or fall back; fail; shrink: a falling back.

Ye both forewearing be; therefore a while I read you rest, and to your bowers recoil. *Spenser.*

The very thought of my revenges that way Recoil upon me; in himself too mighty.

*Shakespeare.*

Who in deep mines for hidden knowledge toils, Like guns o'ercharged, breaks, misses, or recoils.

*Denham.*

Revenge, at first though sweet, Bitter ere long, back on itself recoils.

*Milton.*

My hand's so soft, his heart so hard, The blow recoils, and hurts me while I strike.

*Dryden.*

RECOIL, in gunnery, is the retrograde motion made by any piece of fire arms on being discharged. Cannon are always subject to a recoil, according to the sizes and the charge they contain, &c. Guns, whose vents are a little forward in the chase, recoil most. To lessen the recoil of a gun, the platforms are generally made sloping towards the embrasures of the battery. See PROJECTILES. The following is

A TABLE of the recoil of field guns on travelling carriages, on elm planks.

Nature.	Charge.	1 Shot	2 Shot	Case Shot at 3° 45' Elevation
		at 1° 30' Elevation.	at 1° 30' Elevation.	
	lbs. oz.	Feet.	Feet.	Feet.
12 Pr. Med.	4 0	12	25	8½
6 Pr. Heavy	2 0	7	11	7½
6 Pr. Light	1 8	12	21	10
3 Prs. Heavy	1 0	3	5	3½

The recoil of sea-service iron-guns, on ship-carriages, upon a horizontal platform, is as follows:—

Charge of Powder and Shot.	Elevation.	32	24	18
		pounders.	pounders.	pounders.
	Deg.	Ft. In.	Ft. In.	Ft. In.
½ of Powder and 1 Shot	2	11 0	11 0	10 6
½ of Powder and 2 Shot	4	19 6	18 6	18 0
½ of Powder and 2 Shot	7	11 6	12 0	12 0

Recoil of land service iron mortars, on iron beds.

		Ft. In.
13-inch with a charge of 6 lbs.		4 2½
10-inch	3 lbs.	2 10
2-inch	1 lb. 9 oz.	3 10

RECOIN, *v. a.* } Re and coin. To coin  
RECOINAGE, *n. s.* } over again: the act of coining anew.

The mint gained upon the late statute, by the recoinage of groats and half-groats, now twelvespences and sixpences.

*Bacon.*

Among the Romans, to preserve great events upon their coins, when any particular piece of money grew very scarce, it was often recoined by a succeeding emperor.

*Addison.*

RECOLLECT, *v. a.* } Lat. *recollectus.* To  
RECOLLECTION, *n. s.* } remember; recover to memory or reason; gather again; the noun substantive corresponding.

It did relieve my passion much;  
More than light airs and recollected terms  
Of these most brisk and giddy paced times.

*Shakespeare.*

Let us take care that we sleep not without such a recollection of the actions of the day as may represent any thing that is remarkable, as matter of sorrow or thanksgiving.

*Taylor.*

Finding the recollection of his thoughts disturb his sleep, he remitted the particular care of the composition.

*Fell.*

The Tyrian queen

Admired his fortunes, more admired the man;  
Then recollected stood.

*Dryden's Æneis.*

Recollection is when an idea is sought after by the mind, and with pain and endeavour found, and brought again in view.

*Locke.*

Recollect every day the things seen, heard, or read, which made any addition to your understanding.

*Watts's Logick.*

RECOMFORT, *v. a.* Re and comfort. To comfort or console again.

What place is there left, we may hope our woes to recomfort?

*Sidnev.*

Ne'er through an arch so hurried the blown tides,  
As the recomforted through the gates.

*Shakespeare.*

As one from sad dismay

Recomforted, and after thoughts disturbed,  
Submitting to what seemed remediless.

*Milton.*

RECOMMEND, *v. a.* } *Fr. recommander.*  
RECOMMENDABLE, *adj.* } Re and commend.  
RECOMMENDATION, *n. s.* } To praise earnestly;  
RECOMMENDATORY, *adj.* } make acceptable:  
RECOMMENDER, *n. s.* } commendable is,

worthy of praise; the act or mode of praising; that which secures preference; qualification: recommendatory, that which commends: recommender, he who commends.

They had been recommended to the grace of God.

*Acts xiv.*

Mæcenas recommended Virgil and Horace to Augustus, whose praises helped to make him popular while alive, and after his death have made him precious to posterity.

*Dryden.*

Poplicola's doors were opened on the outside, to save the people even the common civility of asking entrance; where misfortune was a powerful recommendation; and where want itself was a powerful mediator.

*Id.*

A decent boldness ever meets with friends,  
Succeeds, and even a stranger recommends.

*Pope.*

Verses *recomendatory* they have commanded me to prefix before my book. *Swift.*

**RECOMMIT**, *v. a.* Re and commit. To commit anew.

When they had bailed the twelve bishops, who were in the Tower, the house of commons expostulated with them, and caused them to be *recommitted*, *Clarendon.*

**RECOMPACT**, *v. a.* Re and compact. To join anew.

Repair

And *recompact* my scattered body. *Donne.*

**RECOMPENSE**, *v. a. & n. s.* Fr. *recompenser*; Lat *re* and *compenso*. To repay; requite; compensate; redeem: as a noun-substantive, reward; compensation; equivalent.

If the man have no kinsman to *recompense* the trespass unto, let it be *recompensed* unto the Lord. *Numbers v. 8.*

Hear from heaven, and requite the wicked, by *recompensing* his way upon his own head. *2 Chron.*

*Recompense* to no man evil for evil, *Rom. xii. 17.*  
Thou'rt so far before,

That swiftest wing of *recompense* is slow

To overtake thee. *Shakspeare.*

Wise men thought the vast advantage from their learning and integrity an ample *recompense* for any inconvenience from their passion. *Clarendon.*

He is long ripening, but then his maturity, and the complement thereof, *recompenseth* the slowness of his maturation. *Hale.*

Your mother's wrongs a *recompense* shall meet, I lay my sceptre at her daughter's feet. *Dryden.*

**RECOMPILEMENT**, *n. s.* Re and compilement. New compilement.

Although I had a purpose to make a particular digest or *recompilement* of the laws, I laid it aside. *Bacon.*

**RECOMPOSE**, *v. a.* } Fr. *recomposer*. Re  
**RECOMPOSITION**, *n. s.* } and *compose*. To

settle, quiet; or adjust anew; the noun-substantive corresponding.

Elijah was so transported, that he could not receive answer from God, till by musick he was *recomposed*. *Taylor.*

We produced a lovely purple, which we can destroy or *recompose* at pleasure, by severing or reapproaching the edges of the two irises. *Boyle.*

**RECONCILE**, *v. a.* } Fr. *reconciler*;  
**RECONCILEABLE**, *adj.* } Lat. *reconcilio*.

**RECONCILEABLENESS**, *n. s.* } To restore to  
**RECONCILEMENT**, } kindness or favor;  
**RECONCILER**, } restore to  
**RECONCILIATION**. } consistency;

make consistent: the adjective and first noun substantive corresponding: reconciliation is renewal of kindness or favor; agreement; and synonymous with reconciliation: a reconciler, he who effects reconciliation; a peace-maker.

So thou shalt do for every one that erreth and is simple, so shall ye *reconcile* the house. *Ezekiel.*

He might be a merciful and faithful high priest to make *reconciliation* for sin. *Hebrews ii. 17.*

Injury went beyond all degree of *reconciliation*. *Sidney.*

This noble passion,

Child of integrity, hath from my soul Wiped the black scruples, *reconciled* my thoughts To thy good truth and honour. *Shakspeare.*

What we did was against the dictates of our own conscience; and consequently never makes that act

*reconcilable* with a regenerate estate, which otherwise would not be so. *Hammond.*

Jarres concealed are half *reconciled*; which if generally known, 'tis a double task to stop the breach at home, and men's mouths abroad. *Faller.*

Many wise men who knew the treasurer's talent in removing prejudice, and *reconciling* himself to wavering affections, believed the loss of the duke was unseasonable. *Clarendon.*

Let him live before thee *reconciled*. *Milton.*

Creature so fair! his *reconciliation* seeking, Whom she had displeased. *Id. Paradise Lost.*

He not only attained his purpose of uniting distant parties unto each other, but, contrary to the usual fate of *reconcilers*, gained them to himself. *Fell.*

Part of the world know how to accommodate St. James and St. Paul, better than some late *reconcilers*. *Norris.*

Worldly affairs and recreations may hinder our attendance upon the worship of God, and are not *reconcilable* with solemn assemblies. *Nelson.*

Submit to Cæsar, And *reconcile* thy mighty soul to life. *Addison.*

The different accounts of the numbers of ships are *reconcilable*, by supposing that some spoke of the men of war only, and others added the transports. *Arbutnot.*

The bones, to be the most convenient, ought to have been as light as was *reconcilable* with sufficient strength. *Cheyne.*

On one side great reserve, and very great resentment on the other, have inflamed animosities, so as to make all *reconciliation* impracticable. *Swift.*

Contending minds to *reconcile*. *Id.*

**RECONDENSE**, *v. a.* Re and condense. To condense anew.

In the heads of stills and necks of colipiles, such vapours quickly are by a very little cold *recondensed* into water. *Boyle.*

**RECONDITE**, *adj.* Lat. *reconditus*. Secret; profound; abstruse.

A disagreement between thought and expression seldom happens, but among men of more *recondite* studies and deep learning. *Felton.*

**RECONDUCT**, *v. a.* Fr. *reconduit*; Lat. *reconductus*. Re and conduct. To conduct again.

Wanderest thou within this lucid orb, And strayed from those fair fields of light above, Amidst this new creation want'st a guide, To *reconduct* thy steps? *Dryden's State of Innocence.*

**RECONJOIN**, *v. a.* Re and conjoin. To join anew.

Some liquors, although colorless themselves, when elevated into exhalations, exhibit a conspicuous colour, which they lose again when *reconjoined* into a liquor. *Boyle.*

To **RECONNOITRE** [Fr.] in military affairs, implies to view and examine the state of things, in order to make a report thereof. Parties ordered to reconnoitre are to observe the country and the enemy: to remark the routes, conveniences, and inconveniences of the first; the position, march, or forces of the second. In either case they should have an expert geographer, capable of taking plans readily; he should be the best mounted of the whole, in case the enemy happen to scatter the escort, that he may save his plans and ideas.



**RECONQUER**, *v. a.* Fr. *reconquerir*. Re and conquer. To conquer again.

Chatterton undertook to *reconquer* Ogier. *Davies*.

**RECONVENE**, *v. a.* Re and convene. To assemble anew.

A worse accident fell out about the time of the two houses *reconvening*, which made a wonderful impression. *Clarendon*.

**RECONSECRATE**, *v. a.* Re and consecrate. To consecrate anew.

If a church should be consumed by fire, it shall, in such a case, be *reconsecrated*. *Ayliffe's Parergon*.

**RECONVEY**, *v. n.* Re and convey. To convey again.

As rivers lost in seas, some secret vein Thence *reconveys*, there to be lost again. *Denham*.

**RECORD**, *v. a. & n. s.* } Fr. *recorder*; Lat.

**RECORD'ER**, *n. s.* } *recorder*. To register; celebrate; recite: a register; authentic memorial; remembrance: a recorder is he whose business it is to keep records; the rolls of a city, &c.; also a kind of flute.

I call heaven and earth to *record* this day against you, that I have set before you life and death.

*Deut. xxx. 20.*

Those things that are *recorded* of him, and his impiety, are written in the chronicles. *I Esdras i.*

The shepherds went among them, and sung an eclogue, while the other shepherds, pulling out *recorders*, which possess the place of pipes, accorded their music to the others voice. *Sidney*.

He shall *record* a gift

Here in the court of all he dies possessed.

Unto his son Lorenzo. *Shakspeare*.

Is it upon *record*? or else reported

Successively, from age to age? *Id.*

I never shall have length of life enough,  
To rain upon remembrance with mine eyes,  
That it may grow and sprout as high as heaven  
For *recording* to my noble husband. *Id.*

I asked, what meant this wilful silence?

His answer was, the people were not used

To be spoke to except by the *recorder*. *Id.*

I but your *recorder* am in this,

Or mouth and speaker of the universe,

A ministerial notary; for 'tis

Not I, but you and fame that make the verse.

*Dunne..*

They longed to see the day, to hear the lark  
*Record* her hymns, and chaunt her carols blest.

*Fairfax.*

So even and morn *recorded* the third day.

An ark, and in the ark a testimony,

The *records* of his covenant. *Id.*

Of such a goddess no time leaves *record*,

Who burned the temple where she was adored.

*Dryden.*

If he affirms such a monarchy continued to the flood, I would know what *records* he has it from.

*Locke.*

Thy elder look, great Janus! cast

Into the long *records* of ages past;

Review the years in fairest action drest. *Prior.*

The office of *recorder* to this city being vacant, five or six persons are soliciting to succeed him. *Swift.*

**RECORD, TRIAL BY**, is where a matter of record is pleaded in any action, as a fine, a judgment, or the like; and the opposite party pleads, nul tiel record, that there is no such matter of record existing. Upon this, issue is tendered and joined in the following form, 'and this he prays may be enquired of by the record; and the other does the like;' and hereupon the

party pleading the record has a day given him to bring it in, and proclamation is made in court for him to 'bring forth the record by him in pleading alleged, or else he shall be condemned;' and, on his failure, his antagonist shall have judgment to recover. The trial, therefore, of this issue is merely by the record; for, as Sir Edward Coke observes, a record or enrolment is a monument of so high a nature, and importeth in itself such absolute verity, that if it be pleaded that there is no such record, it shall not receive any trial by witness, jury, or otherwise, but only by itself. Thus titles of nobility, as whether earl or not earl, baron or not baron, shall be tried by the king's writ or patent only, which is matter of record. Also, in case of an alien, whether alien, friend, or enemy, he shall be tried by the league or treaty between his sovereign and ours; for every league or treaty is of record. And also, whether a manor be held in ancient demesne or not, shall be tried by the record of doomsday in the king's exchequer.

The **RECORDER** is a person whom the mayor and other magistrates of a city or corporation associate with themselves, for their direction in matters of justice and proceedings in law; on which account this person is generally a counsellor well skilled in the law. No recorder of London is mentioned before 1304. He is the first officer in order of precedence that is paid a salary, which originally was no more than £10 sterling per annum, with some perquisites; but it has from time to time been augmented to upwards of £1000 per annum. This office has sometimes been executed by a deputy.

**RECORDE** (Robert), M. D., an English physician and antiquarian of the sixteenth century. He was educated at Cambridge, where he took his degrees, and was the first Englishman who wrote on Algebra. He was also well versed in the Saxon language, and collected many historical and other ancient MSS. His learning, however, unfortunately did not prevent his being imprisoned in the King's Bench prison for debt, where he died in 1558.

**RECOUCH**, *v. a.* Re and couch. To lie down again.

Thou mak'est the night to overvail the day;  
Then lions' whelps lie roaring for their prey,  
And at thy powerful hand demand their food;  
Who when at morn they all *recouch* again,  
Then toiling man till eve pursues his pain. *Wotton.*

**RECOVER**, *v. a. & v. n.* } Fr. *recouvrir*;  
**RECOVERABLE**, *adj.* } Lat. *recupero*. To

**RECOVERY**, *n. s.* } restore; repair;  
renew; regain; release: grow healthy or free from disease or evil: recoverable is, possible to be regained: recovery, restoration; act or power of regaining: in law, act of cutting off an entail.

Would my lord were with the prophet; for he would *recover* him of his leprosy. *2 Kings v. 3.*

The Spirit of the Lord is upon me, to preach the gospel to the poor, and *recovering* of sight to the blind. *Luke iv. 18.*

That they may *recover* themselves out of the snare of the devil, who are taken captive by him.

These Italians, in despite of what could be done, *recovered* Tiliaventum. *Annals.*

The forest is not three leagues off;  
If we recover that, we're sure enough. *Shakspeare.*

A prodigal's course

Is like the sun's, but not like his, *recoverable*, I  
fear. *Id.*

What should move me to undertake the *recovery* of  
this, being not ignorant of the impossibility? *Id.*

The spirit of wantonness is sure scared out of him;  
if the devil have him not in fee simple, with fine and  
*recovery*. *Id.*

Once in forty years cometh a pope, that casteth his  
eye upon the kingdom of Naples, to *recover* it to the  
church. *Bacon.*

They promised the good people ease in the matter  
of protections, by which the debts from parliament  
men and their followers were not *recoverable*.

*Clarendon.*

Adam, by this from the cold sudden damp  
*Recovering*, his scattered spirits returned. *Milton.*

The clouds dispelled, the sky resumed her light,  
And nature stood *recovered* of her fright. *Dryden.*

Any other person may join with him that is in-  
jured, and assist him in *recovering* from the offender  
so much as may make satisfaction. *Locke.*

The sweat sometimes acid, is a sign of *recovery*  
after acute distempers. *Arbutnot on Aliments.*

**RECOVERY, or COMMON RECOVERY**, in Eng-  
lish law. Common recoveries were invented by  
the ecclesiastics to elude the statutes of mort-  
main; and afterwards encouraged by the finesse  
of the courts of law, in order to put an end to  
all fettered inheritances, and bar not only estates-  
tail, but also all remainders and reversions ex-  
pectant thereon. A common recovery is a suit or  
action, either actual or fictitious; and in it the  
lands are recovered against the tenant of the  
freehold; which recovery, being a supposed ab-  
judication of the right, binds all persons, and  
vests a free and absolute fee-simple in the re-  
coverer. There must be three persons at least to  
make a common recovery, a recoverer, a recov-  
eree, and a vouchee. The recoverer is the  
plaintiff or demandant, that brings the writ of  
entry. The recoveree is the defendant or tenant  
of the land, against whom the writ is brought.  
The vouchee is he whom the defendant or tenant  
voucheeth or calls to warranty of the land in de-  
mand, either to defend the right, or to yield him  
other lands in value, according to a supposed  
agreement. And, this being by consent and per-  
mission of the parties, it is therefore said that a  
recovery is suffered.

The operation of this legal fiction not being  
generally well understood, judge Blackstone has  
endeavoured to explain it in detail.

'Let us,' says he, 'in the first place, suppose  
David Edwards to be tenant of the freehold, and  
desirous to suffer a common recovery, in order  
to bar all entails, remainders, and reversions,  
and to convey the same in fee-simple to Francis  
Golding. To effect this, Golding is to bring an  
action against him for the lands; and he accord-  
ingly sues out a writ, called a *præcipe quod  
reddat*, because those were its initials or most  
operative words, when the law proceedings were  
in Latin. In this writ the demandant, Golding,  
alleges that the defendant, Edwards (here called  
the tenant), has no legal title to the land; but  
that he came into possession of it after one Hugh  
Hunt had turned the demandant out of it.  
The subsequent proceedings are made up into a

Vol. XVIII

record or recovery roll, in which the writ and  
complaint of the demandant are first recited;  
whereupon the tenant appears, and calls upon  
one Jacob Moreland, who is supposed, at the  
original purchase, to have warranted the title to  
the tenant; and thereupon he prays that the  
said Jacob Moreland may be called in to defend  
the title, which he so warranted. This is called  
the voucher, vocatio, or calling of Jacob More-  
land to warranty; and Moreland is called the  
vouchee. Upon this, Jacob Moreland, the  
vouchee, appears, is impleaded, and defends the  
title. Whereupon Golding, the demandant,  
desires leave of the court to imparl, or confer  
with the vouchee in private; which is (as usual)  
allowed him. And soon afterwards the de-  
mandant, Golding, returns to court, but More-  
land the vouchee disappears, or makes the de-  
fault. Whereupon judgment is given for the  
demandant, Golding, now called the recoverer,  
to recover the lands in question against the ten-  
ant, Edwards, who is now the recoveree; and  
Edwards has judgment to recover of Jacob More-  
land lands of equal value, in recompense for the  
lands so warranted by him, and now lost by his  
default; which is agreeable to the doctrine of  
warranty. This is called the recompense, or re-  
covery in value. But Jacob Moreland having no  
lands of his own, being usually the cryer of the  
court (who, from being frequently thus vouched,  
is called the common vouchee) it is plain that  
Edwards has only a nominal recompense for the  
lands so recovered against him by Golding;  
which lands are now absolutely vested in the  
said recoverer by judgment of law, and seisin  
thereof is delivered by the sheriff of the county.  
So that this collusive recovery operates merely  
in the nature of a conveyance in fee-simple,  
from Edwards the tenant in tail, to Golding the  
purchaser.'

**RECOUNT, v. a.** } Fr. *reconter*. To relate  
**RECOUNTMENT.** } in detail; tell distinctly:  
relation; recital.

Bid him *recount* the fore-recited practices.

*Shakspeare.*

When from the first to last, betwixt us too,  
Tears our *recountments* had most finely bathed;  
As how I came into that desert place. *Id.*

Plato in Timæo produces an Egyptian priest, who  
*recounted* to Solon out of the holy books of Egypt the  
story of the flood universal, which happened long be-  
fore the Grecian inundation. *Raleigh.*

The talk of worldly affairs hindereth much, al-  
though *recounted* with a fair intention: we speak  
willingly, but seldom return to silence. *Taylor.*

Say from these glorious seeds what harvest flows,  
*Recount* our blessings, and compare our woes.

*Dryden.*

**RECOURSE, n. s.** } Fr. *recours*; Lat. *re-*  
**RECOURSE'UL, adj.** } *cursorus*. Frequent pas-  
sage; return; renewed attack or application;  
hence the common sense of application for help  
or protection; access: *recourseful* is, moving  
alternately.

The doors be lockt,

That no man hath *recourse* to her by night.

*Shakspeare.*

In that *recourseful* deep.

*Drayton.*

Thus died this great peer, in a time of great re-  
*course* unto him and dependance upon him, the house  
and town full of servants and suitors. *Hutton.*

2 E

Preventive physic, by purging noxious humours and the causes of diseases, preventeth sickness in the healthy, or the *recourse* thereof in the valetudinary.

*Broune's Vulgar Errors.*

The council of Trent commends the making *recourse*, not only to the prayers of the saints, but to their aid and assistance.

*Stillingfleet.*

All other means have failed to wound her heart, Our last *recourse* is therefore to our art.

*Dryden.*

REC'REANT, *adj.* Fr. *recreant*. Cowardly; meanspirited; subdued; fallen; apostate.

Let be that lady debonaire,

Thou *recreant* knight, and soon thyself prepare To battle.

*Spenser.*

Dost

Thou wear a lion's hide? doff it for shame, And hang a calf's skin on those *recreant* limbs.

*Shakspeare.*

Who for so many benefits received

Turned *recreant* to God, ingrate and false, And so of all true good himself despoiled.

*Milton.*

The knight, whom fate and happy chance shall grace

From out the bars to force his opposite,

Or kill, or make him *recreant* on the plain,

The prize of valour and of love shall gain.

*Dryden.*

REC'REATE, *v. n.* } Fr. *recreer*; Lat. *re-*

REC'REATION, *n. s.* } *creo*. To refresh; re-

REC'REATIVE, *adj.* } *vive*; to relieve after or avert weariness; delight: the noun-substantive and adjective corresponding.

The chief *recreation* she could find in her anguish was sometime to visit that place, where first she was so happy as to see the cause of her unhap.

*Sidney.*

I'll visit

The chapel where they lie, and tears shed there, Shall be my *recreation*.

*Shakspeare. Winter's Tale.*

Let the musick be *recreative*, and with some strange changes.

*Bacon.*

Take a walk to refresh yourself with the open air, which inspired fresh doth exceedingly *recreate* the lungs, heart, and vital spirits.

*Harvey.*

Let not your *recreations* be lavish spenders of your time; but choose such as are healthful, *recreative*, and apt to refresh you; but at no hand dwell upon them.

*Taylor.*

He walked abroad, which he did not so much to *recreate* himself, as to obey the prescripts of his physician.

*Fell.*

These ripe fruits *recreate* the nostrils with their aromatic scent.

*More's Divine Dialogues.*

The access these trifles gain to the closets of ladies seem to promise such easy and *recreative* experiments, which require but little time or charge.

*Boyle.*

You may have the *recreation* of surprising those with admiration who shall hear the deaf person pronounce whatsoever they shall desire, without your seeming to guide him.

*Holder's Elements of Speech.*

Nor is that man less deceived, that thinks to maintain a constant tenure of pleasure, by a continual pursuit of sports and *recreations*: for all these things, as they refresh a man when weary, so they weary him when refreshed.

*South.*

RECREATION ISLAND, a fertile island in the Southern Pacific Ocean, discovered in the year 1722 by Roggewin. It is twelve leagues in circuit, and some of the ship's company obtained a quantity of antiscorbutic herbs here, but venturing into the country, were assaulted by the natives, who stoned some of them to death, and wounded almost all. Many of the islanders were killed in return by their fire-arms. The

soil is elevated, and produces sugar-canes, cocoa-nuts, pomegranates, Indian figs, &c. The inhabitants are well-made, robust, and full of vivacity; their bodies were painted.

REC'REMENT, *n. s.* } Lat. *recrementum*.

REC'REMENTAL, *adj.* } Dross; spume; superfluity: drossy.

The vital fire in the heart requires an ambient body of a yielding nature, to receive the superfluous serosities and other *recrements* of the blood.

*Boyle.*

REC'RIMINATE, *v. n. & v. a.* } Fr. *recrimin-*

REC'RIMATION, *n. s.* } *ner*; Lat. *re* and *crimino*r. To return one accusation with another; the accusation made in return.

It is not my business to *recriminate*, hoping sufficiently to clear myself in this matter.

*Stillingfleet.*

How shall such hypocrites reform the state,

On whom the brothers can *recriminate*?

Did not Joseph lie under black intamy? he scorched so much as to clear himself, or to *recriminate* the stumpet.

*South.*

Public defamation will seem disobliging enough to provoke a return, which again begets a rejoinder, and so the quarrel is carried on with mutual *recreminations*.

*Government of the Tongue.*

RECRUIT, *v. a., v. n., & n. s.* Fr. *recruter*.

To repair; waste; supply an army; with new men; raise new soldiers; supply of any thing wasted. Pope has used it improperly for a substitute of something wanting; a new soldier.

He trusted the earl of Holland with the command of that army, with which he was to be *recruited* and assisted.

*Clarendon.*

Increase thy care to save the sinking kind, With greens and flow'rs *recruit* their empty hives, And seek fresh forage to sustain their lives.

*Dryden.*

The pow'rs of Troy

With fresh *recruits* their youthful chief sustain:

Not their's a raw and unexperienced train,

But a firm body of embattel'd men.

*Id.*

The French have only Switzerland besides their own country to *recruit* in; and we know the difficulties they meet with in getting thence a single regiment.

*Addison.*

He was longer in *recruiting* his flesh than was usual; but by a milk diet he recovered it.

*Wiseman.*

Her cheeks glow the brighter, *recruiting* their colour;

As flowers by sprinkling revive with fresh odour.

*Granville.*

RECTANGLE, *n. s.* Fr. *rectangle*; Lat. *ectangulus*. A figure which has one angle or more of ninety degrees: the adjective and adverb corresponding.

Bricks moulded in their ordinary *rectangular* form, if they shall be laid one by another in a level row between any supporters sustaining the two ends, then all the pieces will necessarily sink.

*Wotton.*

If all Athens should decree, that in *rectangle* triangle the square, which is made of the side that subtendeth the right angle, is equal to the squares which are made of the sides containing the right angle, geometers would not receive satisfaction without demonstration.

*Broune's Vulgar Errors.*

The mathematician considers the truth and properties belonging to a *rectangle*, only as it is in idea in his own mind.

*Loche.*

**RECTIFY**, *v. a.* } *Fr. rectifier*; *Lat. rectus*  
**RECTIFIABLE**, *adv.* } and *facio*. To make right;  
**RECTIFICATION**. } reform; improve by repeated distillation: rectifiable is, capable of being rectified: rectification, is rectifying; repeated distillation. See below.

That wherein unsouder times have done amiss, the better ages ensuing must *rectify* as they may.

*Hooker.*

It shall be bootless

That longer you defer the court, as well

For your own quiet, as to *rectify*

What is unsettled in the king. *Shakspeare.*  
 At the first *rectification* of some spirit of salt in a retort, a single pound afforded no less than six ounces of phlegm. *Boyle.*

The natural heat of the parts being insufficient for a perfect and thorough digestion, the errors of one concoction are not *rectifiable* by another. *Browne.*

The substance of this theory I mainly depend on, being willing to suppose that many particularities may be *rectified* upon further thoughts. *Burnet.*

If those men of parts, who have been employed in vitiating the age, had endeavoured to *rectify* and amend it, they needed not have sacrificed their good sense to their fame. *Addison.*

The false judgments he made of things are owned; and the methods pointed out by which he *rectified* them. *Atterbury.*

**RECTIFICATION** is in fact a second distillation, in which substances are purified by their more volatile parts being raised by heat carefully managed. Sometimes indeed the rectifier has recourse to a third and even a fourth distillation, when he wishes his spirits or goods, as they are technically called, to be very clean and pure.

The objects of distillation, considered as a trade, are chiefly spirituous liquors; and the distillation of compound spirits and simple water, or those waters that are impregnated with the essential oil of plants, is commonly called rectification.

Malt spirit, and indeed spirits from other substances, must be brought into the state of alcohol, before it is adapted to internal uses, after which it is said to be more fit for all the various internal uses than even French brandy, it being by this purification a more uniform, hungry, tasteless spirit, than any other spirits which are frequently esteemed much better. A quarter of malt, according to its goodness and the season of the year, will afford from eight to fourteen gallons of alcohol. The malt distiller always gives his spirit a single rectification per se to purify it a little, and in this state, though certainly not at all adapted to internal uses, it is frequently and at once distilled into gin or other ordinary compound liquors for the common people. The Dutch never give it any farther rectification than this:—They distil the wash into low wines, and then at once into full proof spirit, from which they manufacture their celebrated Hollands' geneva, which they export to foreign countries. Malt spirit, in its unrectified state, is usually found to have the common bubble proof, which makes it a marketable commodity, and which is obtained by mixing with it a certain portion of the gross oil of the malt; this indeed gives the rectifier much trouble if he require a very fine and pure spirit, but in gene-

ral he does not concern himself about this, but mixes it still stronger by alkaline salts, and disguises its taste by the addition of flavoring ingredients. The spirit loses in these processes the vinous character which it had when it came out of the hands of the malt distiller, and is in all respects inferior, except in the disguise of a mixed flavor. The alkaline salts used by the rectifier, destroying the natural vinosity of the spirit, it is necessary to add an extraneous acid to give it a new one, and this is frequently what is denominated in the shops 'spiritus nitri dulcis,' and the common method of applying it is the mixing it to the taste with rectified spirit; and it is said to be this that gives the English malt spirit a flavor something like brandy, which flavor is, however, very apt to fly off, and accordingly experienced manufacturers recommend the addition of a proper quantity of Glauber's strong spirit of nitre, to the spirit in the still. By this means the liquor comes over impregnated with it, the acid is more intimately mixed, and the flavor is retained. The action of the alkali is thus explained:—There is a greater attraction or affinity between the alkaline salt and the water than between the water and the spirit, of course the salt combines with the water contained in the spirit, and sinks with it to the bottom.

With the spirit-gauge of Messrs. Borie and Poujet, the different degrees of spirituousity are very easily ascertained by means of silver weights of various sizes; the heaviest is inscribed with the words Hollands' proof, and the lightest three-sevenths. The other weights serve to mark the intermediate degrees between these two terms. Thus, if you screw to the end of the beam of the spirit gauge the weight denoting Hollands'-proof, and plunge it into three-fifths, the instrument will descend in the liquid below the degree marked on the scale Hollands'-proof, but it returns to that point on the addition of two-fifths of water, so that three-fifths spirit is thus transformed into Hollands'-proof spirit. If, on the contrary, you screw on the three-fifths weight, and plunge the spirit gauge into Hollands'-proof, it will rise in the liquor above the latter mark, and it may be easily carried down to that degree by the addition of alcohol or spirit of wine. When spirits are distilled for the purpose of extracting alcohol, or spirit of wine, the balneum marie is generally employed. The heat is then more gentle and more equal, and the produce of the distillation of superior quality.

Alcohol, or spirit of wine diluted, is used as a beverage. It is the dissolvent of resins, and constitutes the basis of drying varnishes. Spirit of wine serves as a vehicle for the aromatic principle of plants, and is then called spirit of this or that plant. The apothecary likewise employs spirit of wine to dissolve resinous medicines. These dissolutions are denominated tinctures. It forms the base of almost all the different sorts of beverage called liquors. It is sweetened with sugar, or rendered aromatic with all kinds of substances of an agreeable taste or smell. Spirit of wine preserves vegetable and animal substances from fermentation or putrefaction. To

this end it is used for preserving fruits, vegetables, and almost all the objects and preparations relating to the natural history of animals. All the liquors produced by the fermentation of saccharine substances, yield alcohol. But the quantity and quality vary according to the nature of the substances.

It is chiefly in consequence of the ascent of bodies of greater lixivity with certain bodies of greater volatility that there is so much difficulty here of imitating the foreign vinous spirits of other countries, as, for example, French brandies, and West-Indian rums. All these are remarkable by the character of the essential oil that ascends with the spirit, and which gives it the peculiar flavor by which one spirit differs from another. Now we can obtain an essential oil from any of the vegetables that furnish these different spirits; but we cannot, as we have seen, readily obtain a spirit altogether tasteless, and destitute of some sort of essential oil still combining with it. Could we do this, we could manufacture to perfection an artificial Cogniac brandy or Jamaica rum; but, as we cannot wholly separate the inherent essential oil from the purest and most colorless and most insipid spirit we can obtain, when we add the essential oil with which we mean to flavor it, the union of the two oils gives us a different result, and betrays the artifice to those who are acquainted with the taste of the genuine material.

In order, then, to prepare the oil of wine, or of the grapes from which French brandies are distilled, which are generally the worst that the country affords; the best being selected for the process of wine itself, as yielding a far ampler profit; take some cakes of dry wine- lees, dissolve them in six or eight times their weight of water, distil the liquor with a slow fire, and separate the oil, reserving, for only the nicest uses, that which comes over first, the succeeding oil being coarser and more resinous. Having procured this fine oil of wine, it may be dissolved in alcohol; by which means it may be preserved a long time, fully possessed of all its flavor, but otherwise it will soon grow rancid. With a fine essential oil of wine, thus procured, and a pure and tasteless spirit, French brandies may be imitated to some degree of perfection. The essential oil, it should be observed, must be drawn from the same kind of lees as the brandy to be imitated was procured from; that is, in order to imitate Cogniac brandy, it will be necessary to distil the essential oil from Cogniac lees; and the same for any other kind of brandy. For as different brandies have different flavors, and as these flavors are entirely owing to the essential oil of the grape, it would be ridiculous to endeavour to imitate the flavor of Cogniac brandy with an essential oil procured from the lees of Bourdeaux wine. When the flavor of the brandy is well imitated, other difficulties are still behind. The flavor, though the essential part, is not the only one; the color, the proof, and the softness, must also be regarded, before a spirit that perfectly resembles brandy can be procured. With regard to the proof, it may be easily accomplished, by using a spirit rectified above proof; which, after being intimately

mixed with the essential oil of wine, may be let down to a proper standard with fair water; and the softness may, in a great measure, be obtained by distilling and rectifying the spirit with a gentle fire; and what is wanting of this criterion in the liquor when first made, will be supplied by time; for it is time alone that gives this property to French brandies, they being, at first, acrid, foul, and fiery. But, with regard to the color, a particular method is required to imitate it to perfection, which may be effected by means of treacle or burnt sugar.

The spirit distilled from molasses or treacle is tolerably pure. It is made from common treacle, dissolved in water, and fermented in the same manner as the wash for the common malt spirit. But if some particular art be not used in rectifying this spirit, it will not prove so vinous as malt spirit, but less pungent and acrid, though otherwise much cleaner-tasted, as its essential oil is of a less offensive flavor. Therefore, if good fresh wine- lees, abounding in tartar, be well fermented with molasses, the spirit will acquire a greater vinosity and briskness, and approach nearer to the nature of foreign spirits. Where the molasses spirit is brought to the common proof strength, if it be found not to have a sufficient vinosity, it will be very proper to add some dulcified spirit of nitre; and, if the spirit be clean worked, it may, by this addition only, be made to pass for French brandy. Great quantities of this spirit are used in adulterating foreign brandy, rum, and arrack. Much of it is also used in making cherry-brandy, and other cordials, by infusions; but in them all many persons prefer it to foreign brandies. Molasses, like all other spirits, is entirely colorless when first extracted; but rectifiers always give it as nearly as possible the color of foreign spirits.

In a similar manner we may imitate foreign spirits of all kinds. Thus, if Jamaica rum be our object instead of French brandy, it will only be necessary to procure some of the tops of the sugar canes, from which an essential oil being drawn and mixed with clear molasses spirit, will give it the real flavor; or at least a flavor as true as a spirit not totally divested of all essential flavor of its own can possibly communicate. The principal difficulty therefore must still lie in procuring a spirit totally, or nearly, free from all flavor of its own.

To rectify their spirit into Holland gin, the Dutch distillers add to every twenty gallons of spirit of the second extraction, about the strength of proof-spirit, three pounds of juniper-berries, and two ounces of oil of juniper, and distil with a slow fire, till the feints begin to ascend; then change the receiving-can. This produces the best Rotterdam gin. An inferior kind is made with a less proportion of berries, sweet fennel-seeds, and Strasburgh turpentine, without a drop of juniper-oil. This last is also a better sort, and though still inferior to that of Rotterdam, is produced in very large quantities at Welsoppe.

It is remarkable that no one method of combinatory rectification, that is, of the rectification performed by means of salt, and other additions, is suited to all the several kinds of spirits; scarcely indeed will any one way serve for any two;

out the method of simple and careful distillation is equally suited to all. Molasses spirit, cyder spirit, wine spirit, or brandy, rum, and arrack, are all improved by it; and all of them are then known to be perfectly rectified, when, in the state of alcohol, they not only prove totally inflammable in a little vessel floating upon cold waters, but when poured into the purest spring water they have not the least power of making any change in it, nor leave any marks of oiliness, or that unctuousity which, on the mixture of the less pure spirits, floats on the top, and in certain lights gives the rainbow colors. See **DISTILLATION**.

Fixed salts are rectified by calcination, dissolution, or filtration.

Metals are rectified, i. e. refined, by the coppel; and reguluses by repeated fusions, &c. In a word, all rectifications are founded upon the same principle; and consist in separating substances more volatile from substances less volatile; and the general method of effecting this is to supply only the degree of heat which is necessary to cause this separation.

**RECTIFIER**, in navigation, an instrument consisting of two circles, either laid one upon, or let into the other, and so fastened together in their centres, that they represent two compasses, one fixed, the other moveable; each of them divided into the thirty-two points of the compass, and 36°, and numbered both ways, from the north and south, ending at the east and west in 90°. The fixed compass represents the horizon, in which the north and all the other points of the compass are fixed and immovable. The moveable compass represents the mariner's compass; in which the north and all other points are liable to variation. In the centre of the moveable compass is fastened a silk thread, long enough to reach the outside of the fixed compass. But, if the instrument be made of wood, there is an index instead of the thread. Its use is to find the variation of the compass, to rectify the course at sea; having the amplitude or azimuth given.

**RECTILINEAR**, *adj.* } Fr. *rectitude*;  
**RECTILINEOUS**, } Latin *rectus* and  
**RECTITUDE**, *n. s.* } *linea*. Consisting of right lines: rectitude is, literally, straightness; hence, and more commonly, mental uprightness; integrity.

There are only three *rectilinear* and ordinate figures, which can serve to this purpose; and inordinate or unlike ones must have been not only less elegant, but unequal. *Ray.*

This image was oblong and not oval, but terminated with two *rectilinear* and parallel sides and two semicircular ends. *Newton.*

Calm the disorders of thy mind, by reflecting on the wisdom, equity, and absolute *rectitude* of all his proceedings. *Atterbury.*

**RECTOR**, *n. s.* } Fr. *recteur*; Lat. *rector*.  
**RECTORSHIP**, } Ruler; lord; governor;  
**RECTORY**, } parson of an unimpropriated parish: rectorship and rectory are both used for his office; and the latter for his residence also.

Had your bodies

No heart among you? or had your tongues no cry  
 Against the *rectorship* of judgment? *Shakspeare.*

A *rectory* or parsonage is a spiritual living, composed of land, tithe, and other oblations of the people, separate or dedicate to God in any congregation for the service of his church there, and for the maintenance of the governor or minister thereof, to whose charge the same is committed. *Spelman.*

God is the supreme *rector* of the world, and of all those subordinate parts thereof. *Hale.*

When a *rector* of a university of scholars is chosen by the corporation or university, the election ought to be confirmed by the superior of such university. *Ayliffe's Parergon.*

**RECTOR** is a term applied to several persons whose offices are very different: as, 1. The *rector* of a parish is a clergyman that has the charge and cure of a parish, and possesses all the tithes, &c. 2. The same name is also given to the chief elective officer in several foreign universities, particularly in that of Paris, and also in those of Scotland. 3. It is also applied to the head master of large schools in Scotland, as in the high school of Edinburgh. 4. *Rector* is also used in several convents for the superior officer who governs the house: and the Jesuits gave this name to the superiors of such of their houses as are either seminaries or colleges. 5. The head of Lincoln College, in Oxford, is also called *rector*.

**RECTUM**, in anatomy, the last of the large intestines. See **ANATOMY**.

**RECTUS**, in anatomy, a name common to several pairs of muscles, so called on account of the straightness of their fibres. See **ANATOMY**.

**RECUBATION**, *n. s.* } Lat. *recubo*. The  
**RECUMBENCY**, } act of lying or lean-  
**RECUMBENT**, *adj.* } ing: this both sub-  
 stantives signify, and the adjective corresponds.

Whereas our translation renders it sitting, it cannot have that illation, for the French and Italian translations express neither position of session or *recubation*. *Broune.*

When the mind has been once habituated to this lazy *recumbency* and satisfaction on the obvious surface of things, it is in danger to rest satisfied there. *Locke.*

The Roman *recumbent*, or more properly *accumbent*, posture in eating was introduced after the first Punic war. *Arbutnot.*

**RECUPERADORES**, among the ancient Romans, were commissioners appointed to take cognizance of private matters in dispute between the subjects of the state and foreigners, and to take care that the former had justice done them. It came at last to be used for commissioners, to whom the prætor referred the determination of any affair between one subject and another.

**RECUPERO** (Alexander), a learned numismatologist, was born about 1740 at Catania, of a noble family. He travelled, with the name of Alexis Motta, through the principal cities of Italy, and employed himself in forming a collection of the Roman consular medals. The examination and classification of these stores engaged him more than thirty years, in the course of which he seems to have obtained an unrivalled acquaintance with the family history of the Romans. His death took place at Rome, October, 1803. He wrote *Instituto Stemmatica, sive de Vera Stemmatum præsertim Romanorum Natura atque Differentia; Annales familiarum Romano-*

rum; and *Annales Gentium Historico-Numismaticæ, sive de Origine Gentium seu Familiarum Romanorum Dissertatio*: also treatises on the Roman weights, and manner of numbering. He was a member of the antiquarian academies of Veletra and Cortona.

**RECUPERO** (Joseph), brother of the preceding, was also a learned mineralogist. He embraced the ecclesiastical profession, and obtained a canonry in the cathedral of Catania. He distinguished himself by his researches concerning Etna, and some details which he communicated to our countryman Brydome, relative to the probable age of the mountain. See *ÆTNA*. He published an oryctographical chart of Etna; and left a work on the same subject in manuscript. His death took place in 1787.

**RECUR', v. n.** Fr. *recourir*; Lat. *recurro*. To come back to the thought; revive in the mind; have recourse to (from the Fr. word).

If to avoid succession in eternal existence, they recur to the punctum stans of the schools, they will thereby very little help us to a more positive idea of infinite duration. *Locke.*

In this life the thoughts of God and a future state often offer themselves to us; they often spring up in our minds, and when expelled, recur again.

The second cause we know, but trouble not ourselves to recur to the first. *Walc.*

When any word has been used to signify an idea, that old idea will recur in the mind when the word is heard. *Watts.*

**RECURE', v. a.** Re and cure. To recover from sickness or labor. Not in use.

Through wise handling and fair governance, I him recured to a better will,  
Purged from the drugs of foul intemperance. *Spenser.*

*Phæbus pure*  
In western waves his weary wagon did recure. *Id.*  
Whatsoever fell into the enemies' hands, was lost without recure: the old men were slain, the young men led away into captivity. *Knolles.*

Thy death's wound  
Which he who comes thy Saviour shall recure,  
Not by destroying Satan, but his works  
In thee and in thy seed. *Milton's Paradise Lost.*

**RECURRENT, adj.** Fr. *recurrent*; Lat. *recurrens, n. s.* } *recurrens.* Returning  
**RECURRENCY,** } from time to time:  
**RECURRENCE,** } return; this last is the  
**RECURRENCE,** }  
sense of all the noun substantives.

Next to lingering durable pains, short intermittent or swift recurrent pains precipitate patients unto consumptions. *Harvey.*

Although the opinion at present be well suppressed, yet, from some strings of tradition and fruitful recurrence of error, it may revive in the next generation. *Brown's Vulgar Errors.*

One of the assistants told the recurrences of the other pendulum hanging in the free air. *Boyle.*

**RECURRENCE,** in anatomy, a name given to several large branches of nerves sent out by the par vagum from the upper part of the thorax to the larynx. See *ANATOMY*.

**RECURRING DECIMALS** are those which repeat in the same order, at certain intervals. Thus, the fraction  $\frac{1}{7}$  is expressed by the recurring decimal 06666, &c.

It is curious that all fractions whose denominator is 7 are expressed by compound recurring

decimals which have the same effective figures, though varied in their position. Thus,

- 1/7 = .142857142857, &c.
- 2/7 = .285714285714, &c.
- 3/7 = .428571428571, &c.
- 4/7 = .571428571428, &c.
- 5/7 = .714285714285, &c.
- 6/7 = .857142857142, &c.

**RECURVIROSTRA,** in ornithology, a genus belonging to the order of grallæ of Linnæus, and that of palmipedes of Pennant and Latham. The bill is long, subulated, bent back, sharp, and flexible at the point. The feet are webbed, and furnished with three toes forwards, and a short one behind. Latham notes of this genus three species, viz. the alba, the Americana, and the avosetta, or the one commonly known.

1. *R. alba*, or *scolopax alba*, is about fourteen inches and a quarter long, its color white, the inferior covers of its wings dusky, its bill orange, its legs brown. Edwards remarks that the bill of this bird is bent upwards, as in the avoset; it is black at the tip, and orange the rest of its length; all the plumage is white, except a tint of yellowish on the great quills of the wing and the tail. Edwards supposes that the whiteness is produced by the cold climate of Hudson's Bay, from which he received it, and that they resume their brown feathers during the summer. It appears that several species of this bird have spread further into America, and have even reached the southern provinces: for Sloane found this species in Jamaica; and Fernandez seems to indicate two of them in New Spain, by the names *chiquatototl* and *elotototl*; the former being like our woodcock, and the latter lodging under the stalks of maize.

2. *R. Americana*, the American avoset, is rather larger and longer than the avoset. The bill is similar, and its color black: the forehead is dusky white: the head, neck, and upper part of the breast, are of a deep cream color: the lower parts of the neck behind white: the back is black, and the under parts from the breast pure white: the wings are partly black, partly white, and partly ash-colored. These birds inhabit North America, and were found by Dampier on the coast of New Holland.

3. *R. avosetta* is about the size of a lapwing in body, but has very long legs. The substance of the bill is soft, and almost membranous at its tip: it is thin, weak, slender, compressed horizontally, and incapable of defence or effort. These birds are variegated with black and white, and during the winter are frequent on the eastern shores of Great Britain. They visit also the Severn, and sometimes the pools of Shropshire. They feed on worms and insects, which they scoop out of the sand with their bills. They lay two eggs, white, with a greenish hue, and large spots of black: these eggs are about the size of a pigeon's. They are found also in various parts of the continent of Europe, in Russia, Denmark, and Sweden, but they are not numerous. They are also found in Siberia, but oftener about the salt lakes of the Tartarian desert, and about the Caspian Sea. They do not appear to wander farther south in Europe than

Italy. Whether from timidity or address, the avoset shuns snares, and is not easily taken.

RECUR'VOUS, *adj.* } Lat. *recurvus*. Bent  
 RECUR'VATION, or } backward: the noun  
 RECUR'VITY, *n. s.* } substantive correspond-  
 ing.

Ascending first into a capsular reception of the breast bone by a serpentine *recurvation*, it ascendeth again into the neck. *Browne.*

I have not observed tails in all; but in others I have observed long *recurvus* tails, longer than their bodies. *Derham.*

RECUSANTS, in law, are such persons, whether papists or other, who refuse to go to church and to worship God after the manner prescribed by the Church of England. Popish recusants are papists who so refuse; and a popish recusant convict is a Catholic convicted of such offence. See ROMAN CATHOLICISM.

RECUSE', *v. n.* Fr. *recuser*; Lat. *recuso*. To refuse. A juridical word.

All that are *recusants* of holy rites. *Holyday.*

The humility, as well of understanding as manners of the fathers, will not let them be troubled when they are *recused* as judges. *Digby.*

They demand of the lords, that no *recusant* lord might have a vote in passing that act. *Clarendon.*

A judge may proceed notwithstanding my appeal, unless I *recuse* him as a suspected judge.

*Ayliffe.*

RED, *adj.* } Saxon *reð*; Welsh  
 RED'BREAST, *n. s.* } *rhud*; Dan. *rad*; Belg.  
 RED'COAT, } *rood*; Goth. *riod*; from  
 RED'DEN, *v. a. & v. n.* } the Greek *ερυθρος*. Of  
 RED'DISH, *adj.* } the color of blood:  
 RED'DISHNESS, *n. s.* } one of the primitive  
 RED'HOT, *adj.* } colors, which is sub-

divided into many; as scarlet, vermilion, crimson: the redbreast is a bird named from its color: redcoat, a contemptuous name for a soldier: to *redde* is to make or grow red: reddish, somewhat red: the noun substantive corresponding: red-hot is heated to redness.

His eyes shall be *red* with wine, and his teeth white with milk. *Genesis xlix. 12.*

A bright spot, white and somewhat *reddish*. *Leviticus.*

Look I so pale?

—Ay, and no man in the presence,  
 But his *red* colour hath forsook his cheeks.

*Shakspeare.*

Bring me the fairest creature northward born,  
 To prove whose blood is *reddest*. *Id.*

There was a pretty *redness* in his lips. *Id.*

Iron *redhot* burneth and consumeth not. *Bacon.*

The angelick squadron turned fiery *red*. *Milton.*

In the Red Sea most apprehend a material *redness*, from whence they derive its common denomination. *Browne.*

Two parts of copper and one of tin, by fusion brought into one mass, the whiteness of the tin is more conspicuous than the *reddishness* of the copper. *Boyle.*

ne fearful passenger, who travels late,  
 Shakes at the moonshine shadow of a rush,  
 And sees a *redcoat* rise from every bush. *Dryden.*

In a heaven serene, refulgent arms appear  
*Reddening* the skies, and glittering all around,  
 The tempered metals crash. *Id. Æneid.*

With shame they *reddened*, and with spight grew pale. *Id. Juvenal.*

The glowing *redness* of the berries vies with the verdure of their leaves. *Spectator.*

Turn upon the ladies in the pit,  
 And, if they *redde*n, you are sure 'tis wit.

*Addison.*

The sixth *red* was at first of a very fair and lively scarlet, and soon after of a brighter colour, being very pure and brisk, and the best of all the *reds*. *Newton's Optics.*

Is not fire a body heated so hot as to emit light copiously? for what else is a *redhot* iron than fire? and what else is a burning coal than *redhot* wood? *Id.*

For me the balm shall bleed, and amber blow,  
 The coral *redde*n, and the ruby glow. *Pope.*

The *redhot* metal hisses in the lake. *Id.*

Why heavenly truth,  
 And moderation fair, were the *red* marks  
 Of superstition's scourge. *Thomson's Winter.*

The *redbreast*, sacred to the household gods,  
 Pays to trusted man his annual visit. *Thomson.*

And, instant, lo, his dizzy eye-ball swims  
 Ghastly, and *reddening* darts a threatful glare:  
 Pain with strong grasp distorts his writhing limbs,  
 And Fear's cold hand erects his bristling hair! *Beattie.*

RED is one of the colors called simple or primary: being one of the shades into which the light naturally divides itself, when refracted through a prism.

RED BREAST. See MOTACILLA.

RED LAKE, a lake of North America, a comparatively small lake for this neighbourhood, but at the head of a branch of the Bourbon or Red River. Its form is nearly circular, about sixty miles in circumference. On one side is a tolerably large island. It is almost south-east from Lake Winnipeg, and south-west of the Lake of the Woods. Long. 95° 10' W., lat. 47° 40' N.

RED RIVER, or Natchitoches, a large river of Louisiana, North America, which derives its name from the rich fat earth or marl of that color, borne down by its floods. It rises about long. 105° W., lat. 35° N., and flows into the Mississippi, 240 miles above New Orleans, in Long. 91° 48' W., lat. 31° 15' N. The navigation of the Red River is interrupted at a place called Rapide, 135 miles from its mouth, by a ledge of soft rock of the consistence of pipe-clay, which extends across the river, but might be easily removed. No difficulty, however, is experienced except in low water. About 500 miles from its mouth the voyager meets with a more serious obstacle, namely, the natural bridges or rafts formed by the accumulation of drift wood, under which the current of this great river passes for several miles. They have remained unbroken for so long a period that they have acquired a soil and a growth of timber similar to the surrounding country.

The RED SEA (Sinus Arabicus), is a gulf of the Sea of Arabia, 500 leagues in length and seventy-five in its greatest breadth. It is entered from the gulf of Socotra by a channel, ten leagues wide, in which is the little island of Perim, or Mehan, three miles and a half distant from the Arabian shore, the channel between being the proper strait of Babelmandeb, or the Gate of Tears, alluding to its difficult navigation, and which is the most used, as it is without



danger, and has good anchorage, while the broad passage between the coast of Africa and Perim has too great a depth of water, and, the current usually setting strong into the Bay of Zeila, it is dangerous to be caught here in a calm.

The denomination of Red, given to this sea, is differently accounted for. Buffon accords with the idea that it received it from the color of the coral with which it abounds; but this substance is in general whitish. Others derive it from Edom or Idumea, the ancient names of Upper Egypt washed by the sea, which, signifying red, they suppose to have been given it from the reddish color of the shore. The modern Arabian name is Bahr Suph, Sea of Algæ, from the quantity of these plants that cover the rocks.

Of the sea of Arabia called by the ancients *Mare Erythræum*, Quintus Curtius, after observing that the Ganges empties itself into it, adds, '*Mare certe quo (India) aluitur ne colore quidem abhorret a ceteris. Ab Erythra rege inditum est nomen: propter quod ignari rubere aquas credunt.*' Lib. viii. chap. 9. 'The sea washing India varies not from other seas. It derived its name from king Erythros; on which account the ignorant believe the water to be red.' Pratt's translation. The weed named *suph* by the Hebrews is of a red hue between scarlet and crimson; it abounds in the gulf of Suez. And it is remarkable that the name by which the Arabian Gulf at large is designated throughout the Old Testament is that preserved in the Arab. *Bater Souf*. By the septuagint the original word is rendered *θαλασσα Σιφ*, the Sea of Zeph; *Ερυθρα θαλασσαν*, the Erythrean Sea, and *εσατην θαλασσαν*, the further sea.

At its head the Red Sea forms two gulfs: the western is named the Gulf of Suez, the *Heropolites sinus* of the ancients, and the *Bahr-el-Kolzum*, or *Bahr-el-Suez*, of the Arabs. The eastern gulf of Akaba is the ancient *Elanites sinus*, and the *Bahr-el-Ailah* of the Arabs. The tract which separates these gulfs is named the Desert of Sinai, into which Moses led the children of Israel.

It seems certain that the Red Sea formerly extended several miles farther to the north than it does at present; it now heads about four miles above Suez, and beyond this, running ten miles to the north, is a depressed tract, the level of which is thirty-five feet below that of the sea, and which is only kept from being overflowed by an elevated ridge of sand. The soil of this sunk basin is sea sand and shells; and it has several shallow ponds of salt water. The desiccation of this basin is accounted for by supposing the waves to have accumulated a bar of sand, which, at length, rising above the level of the sea, a lake was formed, the waters of which have been carried off by evaporation. It is generally thought also that the Red Sea is thirty-four feet more elevated than the Mediterranean; hence it would follow, that if the Isthmus of Suez was cut through, the waters of the Red Sea would rush with rapidity into the Mediterranean, while those of the Atlantic running in through the Strait of Gibraltar, an accumulation and concussion would take place, the consequences of which are incalculable. And even supposing

the levels of the two seas to be the same, as there is no tide in the Mediterranean, and a very strong one in the Red Sea, this would alone cause a great body of water to flow from the latter into the former, if the isthmus was broken.

The tides in the Red Sea are considerable from its entrance facing the east, and there being no rivers to counteract the stream. The winds considerably affect these tides; and it is not uncommon, in strong north westers, for the bottom to be left entirely dry on the ebb, between Suez and the opposite shore. The monsoons, which are strong and regular in the open sea of Arabia, are subject to variations in approaching the land. In the gulf of Socotra their direction is usually from the east between October and May, and from the west the other six months; while, within the Red Sea, they blow directly up and down, but with this variation, that the south-east winds blow without intermission in the lower part of the sea, from October to June, when the northerly winds begin and continue for four months. Towards the head of the sea, i. e. the gulf of Suez, northerly winds, on the contrary, prevail for nine months, and blow with great violence. The causes of these variations are evidently the positions of the sea of Arabia and the Mediterranean, with respect to the Red Sea. Thus the monsoon, which is from the east in the gulf of Socotra, changes to the south-east and S. S. E. in the Red Sea, from this sea lying in a direction south-east and north-west; and is of longer continuance, from the atmosphere of the sea of Arabia being for a great part of the year colder than that of the Red Sea. For a similar reason north-west winds are of longest duration at the head of the sea; for the denser air of the Mediterranean is almost constantly flowing towards the more rarified atmosphere of the desert of Suez and Red Sea, and this cause is strongest in the months of June, July, and August, when the presence of the sun has most raised the temperature of these latter; hence north-west winds blow with great violence towards the head of the sea during these months. Though these monsoon winds prevail with great regularity in the middle of the sea, close to the shores, there are, throughout the year, land and sea breezes; but they cannot be taken advantage of in navigating this sea, by reason of the reefs which line the shores, obliging ships to keep at too great a distance during the night to profit by the land wind. The currents mostly run with the wind.

We have no knowledge of a single stream of fresh water reaching the Red Sea. The river Farat, laid down in the charts on the African coast, nearly opposite Judda, is probably only a creek. The Arabian coast is lined by a chain of mountains throughout its whole extent, whose base is from ten to thirty leagues from the sea; the intermediate space being an arid sea sand, totally deprived of fresh water, and naturally producing only a few herbaceous plants, such as the mesembryanthem, euphorbia, stapelia, colquintia, &c. This barren waste, however, abounds with antelopes and other game; and immediately beyond it the scene suddenly changes to an exuberant vegetation, and a profusion of spring water.

The *climate* of the Red Sea differs essentially at its extremities. At Mocha, with the exception of a few light showers about Christmas, rain is unknown; and the thermometer, in July and August, rises to 112° during the day, and never descends below 90° at night. The dews are, throughout the year, extremely heavy.

The African coast of the Red Sea is divided into Abyssinia, Baza, and Upper Egypt. The coast of Abyssinia, being generally avoided by ships navigating in this sea, was very imperfectly known until the visit of lord Valentia in 1804. It is now found to possess several good ports, but also to be of dangerous approach in several places from reefs and islands. From Ras Firmah, the north point of Asab Bay, on which is the negro town of Asab (Sabæ), to Ras Rattah or the Sister Hills, there are several curvatures and good anchorage.

Suez is a modern and a poor place, being ruined by the cessation of commerce during the occupation of Egypt by the French. It is situated on an inlet filled with banks, which dry at half tide, and crossed by a bar two miles and a half below the town, with but ten or eleven feet high water: inside the depths between the banks are eight and nine feet at low, and fifteen to sixteen feet high water springs. This forms a kind of inner harbour, in which the country vessels lay when they require careening, which is done in a cove or basin at the back of the town. The water used by the inhabitants and shipping is brought on camels from wells to the east of the town at a considerable distance. The ruins of Clysmæ are visible in a mound of rubbish south of Suez, now called Kolzum. In 1817 a small fleet of English ships arrived here direct from Bombay, in consequence of the desire of the pacha of Egypt to open a direct trade between India and that country.

The Arabian coast of the Red Sea includes Yemen or Tehama, and Hejaz. The coast from Cape Babelmandeb, at the entrance of the strait, to Mocha is clean and bold-to; but from this to the north it is lined with reefs within, and through which the Arab vessels sail by day only.

Niebuhr thinks this was the point at which the Israelites crossed the Red Sea: it is a passage of twenty-fours to Tor on the opposite side; but as he observes, and as we have noticed, there can be no doubt the sea formerly extended much farther north.

The natives point out the valley of Bedeah, and other points of the coast further southward, opposite Ayoun Mousa and the Hammam Faraoun. Dr. Shaw objects, against the opinion which fixes the passage opposite Ayoun Mousa, that there is not sufficient depth of water there to drown so many Egyptians,—an objection which would seem to apply with still greater force to the opinion of Niebuhr and others, who fix upon Suez as the point at which they crossed. But the fact is, that the waters have retired, and the coral shoals have increased so much in every part of the gulf that no decisive argument can be built on the present shallowness of the water. In former times, ships entered the harbour of Kolsoum, which stood higher up than Suez, but, in consequence of the retreat of the waters, that

harbour was deserted, and Suez, which was not in existence towards the end of the fifteenth century, rose on its ruins. Niebuhr crossed the creek at low water on his camel, near the supposed ruins of Kolsoum, and the Arabs, who attended him on foot, were only up to their knees; but no caravan, he says, could pass here without great inconvenience, and certainly not dry-foot. Nor could the Israelites, he remarks, have availed themselves of any coral rocks, as they are so sharp that they would have cut their feet. Moreover, if we suppose that the agency of the tides was employed by divine providence in favoring the passage of the Israelites, the east wind which, blowing all night, divided the waters of the gulf in the middle, preserving a body of water above and below, and laying bare the channel between the walls,—was clearly supernatural. The wind here constantly blows six months north and six months south. And, as this unprecedented ebb of the waters must have been preternatural, not less so was the sudden tempestuous reflux by which the Egyptians were overwhelmed. Perhaps a thick fog, it is suggested, might hasten their destruction. The depth at high water now does not exceed from eight to ten feet, but the same causes which have enlarged the land on the eastern shore, have rendered the gulf shallower. The winds, blowing the sands of Arabia into the Red Sea, are constantly forming shallows among the rocks, and threaten in time to fill up the gulf. Dr. Shaw, however, displays his usual learning and ingenuity in fixing the passage of the Israelites opposite the desert of Shur. Supposing Rameses to have been Cairo, there are two roads, he remarks, by which the Israelites might have been conducted to Pihahhiroth on the coast; the one through the valleys of Jendily, Rumeleah, and Baideah, which are bounded on each side by the mountains of the Lower Thebais; the other, more to the northward, having these mountains for several leagues on the right, and the desert on the left, till it turns through a remarkable breach or ravine in the northernmost range, into the valley of Baideah. The latter he presumes to have been the road taken by the Israelites. Succoth, the first station, signifies only a place of tents; and Etham, the second station, he considers as probably on the edge of the mountainous district of the Lower Thebais. Here the Israelites were ordered to turn (from their line of march), and encamp before Pihahhiroth, i. e. the mouth of the gullet or defile, betwixt Migdol and the sea. This valley he supposes to be identified with that of Baideah, which signifies miraculous, and it is also still called Tiah Beni Israel, the road of the Israelites. Baal-tzephon, over against which they encamped, is supposed to be the mountain still called Jebel Attakkah, the mountain of deliverance. Over against Jebel Attakkah, at ten miles distance, is the desert of Sdur, or Shur, where the Israelites landed. This part of the gulf would, therefore, be capacious enough to cover a numerous army, and yet might be traversed by the Israelites in a night; whereas, from Corondel to Tor, the channel is ten or twelve leagues broad, which is too great a distance to have been travelled by a multitude

with such incumbrances, and the passage from Suez appears as much too short. Having once entered this valley, it might well be said that the wilderness had 'shut them in,' inasmuch as the mountains of Mokattem would deny them a passage to the southward; those in the neighbourhood of Suez would be a barrier to the northward, towards the land of the Philistines; the Red Sea was before them to the east, while Pharaoh with his army closed up the defile behind them. The valley ends in a small bay formed by the eastern extremities of the mountains.

Dennis Bay, in about  $14^{\circ} 35'$ , is according to the French a safe road with a watering place. Hodeida is a considerable town and the sea port of Betelfakie, whence a great quantity of coffee is shipped. Cape Israel is a long projecting point, with a bay on the north sheltered by the island of Camaran. Loheia is at the north extremity of this bay, and is a large town without walls, but with several towers guarded by soldiers; some of the houses are of stone, but the greater number are of mud thatched. The shore is here so shoal that ships cannot anchor nearer than two leagues to the town, and even boats cannot approach it at low water; it has, however, a share of the coffee trade. Ghesan and Attui are towns further north. Camfida (Hejaz) is a considerable town, ten leagues north of which is Bender Dodja, where there is said to be good water. From hence to Cape Ibrahim the land is high with some small towns little known to Europeans.

Judda, the sea-port of Mecca, which is forty miles inland, is a large town with an extensive trade, as well with Europeans from India as with other parts of the Red Sea, particularly Cossire, Suez, and Tor. The harbour is formed by a great number of reefs, and the anchorage is three miles from the town. The town is tolerably built, and is governed by a vizier from Mecca.

The places in succession from Judda, of which we have any knowledge, are Yambo (Jambia), by the Arabs called Jembo el Bahr; it is the port of Medina, a day's journey inland, and is a considerable town, but partly in ruins, with a harbour between two reefs, but very contracted. The land over it is extremely high and rugged. It is a general rendezvous of the Arab vessels bound to and from Egypt, but is never visited by European ships, the natives being treacherous and inhospitable. Bareedy harbour, also formed by shoals, is fourteen leagues farther north.

Ras Abou Mahomet (Pharan promont.) is the extremity of the peninsula that separates the gulfs of Akaba and Suez; it is a very low sandy point, but with deep water close to it, and behind the point a chain of high hills runs through the peninsula to Mount Sinai. Before the centre of the entrance of the Gulf of Akaba, and north of Cape Mahomet, is the island Tiran, elevated in the middle. On the east shore of the entrance of the gulf is Calai el Moatloah (Phenicum oppidum), a large town, whose inhabitants have the name of great robbers, and this gulf is infested by pirates. Near its head is Calaat el Akaba (Elana), whence the gulf has received its name. El Akaba, i. e. the end (of the sea), Vol-

ney thinks it may be the Atslum Gaber of the Bible, which, as well as Ailah on the same gulf, which still retains its name, was a celebrated mart in the time of Solomon. Being in the possession of the Bedouin Arabs, who have no idea of commerce, they are never visited. El Akaba is said to be a Turkish fort, and to possess good water.

The gulf of Suez is entered between Ras Mahomet and the island of Shadwan, the channel being four leagues wide. Tor, the Elim of the Scripture, and the Phenicon of the Romans, is now a wretched village, inhabited by about 100 Greeks, and a few Arab fishermen. The ruins of a well built Turkish fort denote it to have formerly been of more consequence. The description of this place given in the Bible perfectly answers to its appearance at this day, except that three only of the twelve wells are now to be seen, about 200 yards from the beach, and the only verdure is two small clumps of date trees. The water of the wells is less brackish than that of Mocha or Judda, but is in very small quantity, and is only freshened by filtration through the sand of the beach. There are no kind of refreshments except fish, and they are far from abundant, to be procured here. The foot of the ridge of hills which runs through the peninsula is about a day's journey, or six leagues from Tor. Amongst them Mount Sinai raises its lofty head in two peaks, and to the religious mind recalls the scenes described by the sacred historian; it is a vast mass of red granite with white spots. In the little dispersed spots of soil, almonds, figs, and vines, are cultivated, and numerous rills of excellent water gush from the crevices, and wander among these little gardens; at its foot is a monastery of Greek monks. The coasts of this peninsula are lined with coral reefs, and covered with petrifications. The road or harbour of Tor is perfectly safe, being sheltered by reefs running off from the points of a semi-circular bay, having a channel a mile and a half wide. Cape Jehan is eight or nine leagues north-west of Tor.

A mere enumeration of the vast number of islands and reefs, above and under water, scattered throughout the Red Sea, would be equally useless and tedious, we shall therefore confine ourselves to the notice of those which are most conspicuous and best known.

On the African shore are Dhalac Island, seven leagues long, with many islands and reefs near it. St. John's Island, five or six leagues south-east of Emerald Island, has a high hill at the south-east end. Shadwan, at the entrance of the gulf of Suez, is a large and high island.

Nearest to the Arabian shore is the island Rabelmandeb, Perim, or Mehun, anciently Diodiri, three miles and a half from Cape Rabelmandeb, and forming the lesser strait. It is four miles in circuit, of little elevation, but highest in the middle; it is covered with large loose masses of black stone, except in some spots where a thin sea sand covers a coral rock, and exceeds even in sterility the neighbouring continent, a few aromatic plants, and a prickly and leafless shrub of the milky tribe, being the only vegetables: and even these are in so small a quantity, that if

the whole were collected they would not make a fire sufficient to dress a dinner. The attempts of the English to procure fresh water on the island, by digging wells, were fruitless. A few small lizards are the only stationary animals found on the island, but in the season of incubation it is resorted to by vast numbers of gulls to breed; its beaches are also frequented by green turtles in December and January. Though no vestige of habitations is seen on the island, it was evidently once resorted to, a cistern to hold water, built of stone and coated with mortar, still remaining perfect: it is possible this was a work of the Portuguese, when in 1513 they made an unsuccessful attack on Aden. A great number of granite bullets were also discovered by the English, in the water near the island. On the north-west side of the island is a very snug harbour, nearly land-locked, for about four ships. The Arroas are north-west eleven leagues from Mocha, nearly midway between the Arabian and Abyssinian coasts; the great Arroa is elevated. Gebel Zeghir, five leagues north of the Arroa, and six leagues from the Arabian coast, is high, with three small islands on its north side. The Sabugar islands extend from lat. 15° to 15° 10'; they are high, rocky, and barren: the largest, named Gebel Zebayr, has two conical hills. Gebel Tar is of considerable height, as its name denotes (Gebel, mountain—Tar, high), with a volcanic peak. Doohorab, a small low island in 16° 15', covered with trees.

In their persons the Arabs of this neighbourhood exceed the middle size, but are generally thin; they are excellent horsemen, expert in the use of the lance and matchlock, and generally brave. The wandering tribes, named Bedouins, are robbers by profession, and honestly avow their trade, while the Arab of cities, less candid, is equally a robber by extortion. The Arabs, however, possess the virtue of hospitality to strangers who demand their protection, and the eating together is the seal of safety from the Bedouin to his guest. The towns of the Arabs are built of stone or sun-dried bricks. The houses have two stories, with terraced roofs; the front is occupied by the men and the back by the females, who are strictly guarded from the eyes of strangers, for which purpose the tent of the Bedouin is divided by a screen. The Arabs are abstemious in their diet, the common class making only one meal a day of doura, a species of millet, with milk or oil.

**REDAR'GUE**, *v. a.* Lat. *redarguo*. To re-fute. Not in use.

The last wittily *redargues* the pretended finding of coin, graved with the image of Augustus Cæsar, in the American mines. *Hakewill on Providence.*

**REDDITIO**, was the third part of the sacrifice of the heathens, and consisted of the solemn act of putting in again the entrails of the victims, after they had been religiously inspected. See **SACRIFICE**.

**REDDITION**, *n. s.* From Lat. *reddo*. Res-titution.

She is reduced to a perfect obedience, partly by voluntary *reddition* and desire of protection, and partly by conquest. *Howel.*

**RED'DLE**, *n. s.* From red. A sort of mineral.

*Reddle* is an earth of the metal kind, of a tolerably close and even texture: its surface is smooth and somewhat glossy, and it is soft and unctuous to the touch, staining the fingers very much: in England we have the finest in the world. *Hill.*

**REDDLE**, a soft, heavy, red marle, of great use in coloring; and being washed and freed from sand, is often sold by our druggists under the name of bole armeniac.

**REDE**, *n. s. & v. a.* Sax. *næð*. Counsel; advice. Not used.

*I rede thee hence to remove,  
Lest thou the price of my displeasure prove.*

*Spenser.*

Do not as some ungracious pastors do,  
Shew me the steep and thorny way to heaven;  
Whilst he a puffed and reckless libertine,  
Himself the primrose path of dalliance treads,  
And reckes not his own *rede*. *Shakspeare. Hamlet.*

**REDE** (William), a learned English prelate of the fourteenth century, who became bishop of Chichester in 1369. He was the first mathematician of his age. He erected the first library of Merton College, and built the castle of Amberley.

<b>REDEEM'</b> , <i>v. a.</i>	} Lat. <i>redimo</i> . To ransom; buy off from captivity or slavery; pay the penalty of; free by paying any atone-ment or price: hence to compensate; recom-pense; and, in a theological sense, to buy again something that had been devoted to God; deli-ver from the bondage of sin; save time by self-denial: redeemable is capable of redemp-tion; the noun substantive that follows cor-responding: redeemer, he who ransoms or re-deems; the Saviour of the world: redemption, the act of redeeming; price paid; actual delivery of the redeemed: redemptory, adjective, paid for ransom.
<b>REDEEM'ABLE</b> , <i>adj.</i>	
<b>REDEEM'ABLENESS</b> , <i>n. s.</i>	
<b>REDEEM'ER</b> ,	
<b>REDEMP'TION</b> ,	
<b>REDEMP'TORY</b> , <i>adj.</i>	

The firstling of an ass thou shalt *redeem* with a lamb. *Exodus.*  
The kinsman said, I cannot *redeem* it for myself, lest I mar mine inheritance. *Ruth iv. 6.*  
*Redeem* Israel, O God, out of all his troubles. *Psalms xxv.*  
Christ *redeemed* us from the curse. *Gal. iii. 13.*  
The time *redeeming*. *Ephes. v. 16.*  
The Almighty from the grave  
Hath me *redeemed*; he will the humble save. *Sandy.*

She inflamed him so  
That he would algates with Pyrocles fight,  
And his *redeemer* challenged for his foe,  
Because he had not well maintain'd his right. *Spenser.*

How if, when I am laid into the tomb,  
I awake before the time that Romeo  
Come to *redeem* me? there's a fearful point. *Shakspeare.*

This feather stirs, she lives; if it be so,  
It is a chance which does *redeem* all sorrows  
That ever I have felt. *Id. King Lear.*

I every day expect an embassy  
From my *redeemer* to *redeem* me hence;  
And now in peace my soul shall part to heaven. *Shakspeare.*

I every day expect an embassy  
From my *redeemer* to *redeem* me hence;  
And now in peace my soul shall part to heaven. *Shakspeare.*

I every day expect an embassy  
From my *redeemer* to *redeem* me hence;  
And now in peace my soul shall part to heaven. *Shakspeare.*

I every day expect an embassy  
From my *redeemer* to *redeem* me hence;  
And now in peace my soul shall part to heaven. *Shakspeare.*

I every day expect an embassy  
From my *redeemer* to *redeem* me hence;  
And now in peace my soul shall part to heaven. *Shakspeare.*

I every day expect an embassy  
From my *redeemer* to *redeem* me hence;  
And now in peace my soul shall part to heaven. *Shakspeare.*

I every day expect an embassy  
From my *redeemer* to *redeem* me hence;  
And now in peace my soul shall part to heaven. *Shakspeare.*

I every day expect an embassy  
From my *redeemer* to *redeem* me hence;  
And now in peace my soul shall part to heaven. *Shakspeare.*

I every day expect an embassy  
From my *redeemer* to *redeem* me hence;  
And now in peace my soul shall part to heaven. *Shakspeare.*

I charge you, as you hope to have *redemption*,  
That you depart, and lay no hands on me. *Id.*  
Omega sings the exequies,  
And Hector's *redemptory* price.

*Chapman's Iliad.*

Which of you will be mortal to *redeem*  
Man's mortal crime ? *Milton.*  
Man's friend, his Mediator, his designed  
Both ransom and *Redeemer* voluntary. *Id.*  
Utter darkness his place  
Ordnained without *redemption*, without end. *Id.*

When saw we thee any way distressed, and relieved  
thee ? will be the question of those to whom heaven  
itself will be at the last day awarded, as having mi-  
nistered to their *Redeemer*. *Boyle.*

*Redeem* from this reproach my wandering ghost.  
*Druden.*

The Saviour son be glorified,  
Who for lost man's *redemption* died. *Id.*  
The salvation of our souls may be advanced, by  
firmly believing the mysteries of our *redemption*, and  
by imitating the example of those primitive patterns  
of piety. *Nelson.*

REDELIVER, *v. a.* Re and deliver. To de-  
liver back.

I have remembrances of yours,  
That I have longed long to *redeliver*. *Shakspeare.*  
Instruments judicially exhibited are not of the acts  
of courts ; and therefore may be *redelivered* on the  
demand of the person that exhibited them.

*Ayliffe's Parergon.*

REDEMAND', *v. a.* Fr. *redemander*. Re  
and demand. To demand back.

Threescore attacked the place where they were  
kept in custody, and rescued them : the duke *rede-*  
*mands* his prisoners, but receiving excuses resolves to  
do himself justice. *Addiam.*

REDEMPTION, in theology, denotes the reco-  
very of mankind from sin and death, by the obe-  
dience and sacrifice of Christ, who on this  
account is called the Redeemer of the world.  
See THEOLOGY.

REDEMPTION, in law, a right of re-entering  
upon lands, &c., that have been sold and as-  
signed, upon reimbursing the purchase-money,  
with legal costs.

REDENS, REDANS, OR REDANT, in fortifica-  
tion, a kind of indented work in form of the  
teeth of a saw, with salient and re-entering an-  
gles ; to the end that one part may flank or de-  
fend another. See FORTIFICATION.

REDFORD, EAST. See RETFORD, EAST.

REDI (Francis), an Italian physician and  
naturalist, born at Arezzo in Tuscany in 1626.  
His learning recommended him to the office of  
first physician to Ferdinand II. duke of Tuscany ;  
and he contributed towards compiling the Dic-  
tionary of La Crusca. He wrote upon vipers  
and upon the generation of insects. All his  
works are in Italian ; and his language is so  
pure that the authors of the Dictionary of La  
Crusca have often cited them as standards of  
perfection. He died in 1697.

REDI (Thomas), an eminent Italian painter,  
born in Florence in 1685. His historical pictures  
adorn the churches in Etruria. He had also an  
excellent style of painting portraits. He died in  
1726.

REDICULUS, a deity of the Romans, whose  
name is derived from *redire*, to return. The Ro-  
mans erected a temple to this imaginary deity on

the spot where Hannibal retired, when after ap-  
proaching Rome to besiege it, he set out on his  
return.

REDINTEGRATE, *adj.* Lat. *redintegratus*.  
Restored ; renewed ; made new.

Charles VIII. received the kingdom of France in  
flourishing estate, being *redintegrate* in those prin-  
cipal members which anciently had been portions of  
the crown, and were after dissevered ; so as they re-  
mained only in homage, and not in sovereignty.

*Bacon.*

He but prescribes a bare chymical purification of  
nitre, what I teach as a philosophical *redintegration*  
of it. *Boyle.*

REDNITZ, a river of Franconia, formed of  
the Upper and Lower Retzat, which unite five  
miles south of Roth. Joined by the Pegnitz,  
near Furth, it falls into the Maine below Bam-  
berg, being navigable in the lower part of its  
course. It has long been in view to effect a  
communication between this river and the Alt-  
muhl, and by this means to unite the Danube  
with the Rhine. Charlemagne, during his war  
with the Avari, actually ordered this plan to be  
begun upon ; but his attention was soon after  
drawn from it by an invasion of the Saxons ; but  
the remains of his works are still to be seen at a  
village in Pappenheim.

REDOLENT, *adj.* Lat. *redolens*. Sweet of  
scent.

Thy love excels the joys of wine ;  
Thy odours, O how *redolent* !

*Sandys's Paraphrase.*

We have all the *redolence* of the perfumes we burn  
upon his altars. *Boyle.*

Their flowers attract spiders with their *redolency*.  
*Mortimer.*

REDONES, a nation of ancient Gaul, men-  
tioned by Cæsar (De Bell. Gall.), among the  
Armorici ; who inhabited that part of the coun-  
try, now called Rennes and St. Malo, in the ci-  
devant province of Brittany.

REDOUB'LE, *v. a. & v. n.* Fr. *redoubler*.  
Re and double. To repeat in return, or often ;  
to become twice as much.

So ended she ; and all the rest around  
To her *redoubled* that her undersong. *Spenser.*

They were

As cannons overcharged with double cracks,  
So they *redoubled* strokes upon the foe.

*Shakspeare. Macbet*

If we consider that our whole eternity is to take  
its colour from those hours which we here employ in  
virtue or vice, the argument *redoubles* upon us, for  
putting in practice this method of passing away our  
time. *Addison's Spectator.*

REDOUBT', *n. s.* } Fr. *reduit, redout* ;  
REDOUBTABLE, *adj.* } Ital. *ridotta*. The out-  
REDOUBTED. } work of a fortification ;  
a fortress : *redoubtable* is formidable : *redoubted*,  
dreaded ; awful.

So far be mine my most *redoubted* lord,  
As my true service shall deserve your love.

*Shakspeare.*

Every great ship is an impregnable fort, and our  
safe and commodious ports are as *redoubts* to secure  
them. *Bacon.*

The enterprising Mr. Linton, the *redoubtable* rival  
of Mr. Tonson, overtook me. *Pope.*

REDOUBT, in fortification. See FORTIFICA-  
TION.

**REDOUND**, *v. n.* Lat. *redundo*. To be sent back by reaction; hence, reaction or accumulated action generally: and hence to conduce to an end.

The evil, soon Driven back, *redounded*, as a flood on those From whom it sprung. *Milton's Paradise Lost.*

Nor hope to be myself less miserable, By those I seek, but others to make such As I, though thereby worse to me *redound*. *Milton.*  
As both these monsters will devour great quantities of paper, there will no small use *redound* from them to that manufacture. *Guardian.*

The honour done to our religion ultimately *redounds* to God the author of it. *Rogers's Sermons.*

**REDRESS**, *v. a. & n. s.* } Fr. *redresser*. To }  
**REDRESSIVE**, *adj.* } set right; amend; }  
relieve: relief; amendment: the adjective corresponding.

She felt with me, what I felt of my captivity, and straight laboured to *redress* my pain, which was her pain. *Sidnev.*

To seek reformation of evil laws is commendable, but for us the more necessary is a speedy *redress* of ourselves. *Hooker.*

No humble suitors press to speak for right; No, not a man comes for *redress* to thee. *Shakspeare.*

In yonder spring of roses, Find what to *redress* till noon. *Milton.*  
Grief, finding no *redress*, ferment and rage, Nor less than wounds immedicable, Rankle, and fester, and gangrene To black mortification. *Id.*

Lighter affronts and injuries Christ commands us not to *redress* by law, but to bear with patience. *Kettlewell.*

A few may complain without reason; but there is occasion for *redress* when the cry is universal. *Davenant.*

In countries of freedom, princes are bound to protect their subjects in liberty, property, and religion, to receive their petitions, and *redress* their grievances. *Swift.*

The generous band, Who, touched with human woe, *redressive* searched Into the horrors of the gloomy jail. *Thomson.*

**REDRUTH**, a market town and parish of Cornwall, four miles west of Truro, and 263 W. S. W. of London; being situate in the midst of many productive mines. Besides the church of St. Uny, without the town, it has several meeting-houses, and two good charity schools. Markets are held on Tuesday and Friday.

**RED'SEAR**, *v. n.* Red and sear. A term of workmen.

If iron be too cold, it will not feel the weight of the hammer, when it will not batter under the hammer; and, if it be too hot, it will *redsear*, that is, break or crack under the hammer. *Moxon.*

**RED'SHANK**, *n. s.* Red and shank. A contemptuous appellation for some of the people of Scotland; perhaps, however, soldiers with red hose.

He sent over his brother Edward with a power of Scots and *redshanks* unto Ireland, where they got footing. *Spenser.*

**RED-SHANK**. See **SCOLOPAX**.

**RED-START**. See **MOTACILLA**.

**RED-STREAK**, *n. s.* Red and streak. An apple.

There are several sorts of *redstreak*: some sorts of them have red veins running through the whole fruit, which is esteemed to give the cyder the richest tincture. *Mortimer.*

*Redstreak* he quaffs beneath the Chianti vine, Gives Tuscan yearly for thy Scudmore's wine. *Smith.*

**REDUCE**, *v. a.* } Fr. *reuire*; Lat. }  
**REDUCEMENT**, *n. s.* } *reduco*. To bring }  
**REDUCER**, } back; bring to a }  
**REDUCIBLE**, *adj.* } former state; hence }  
**REDUCIBLENESS**, *n. s.* } restore to order or }  
**REDUCTION**, } dominion; sub- }  
**REDUCTIVE**, *n. s. & adj.* } due; bring into a }  
**REDUCTIVELY**, *adv.* } lower state; de- }  
grade; impair: reduction is the act of reducing; as is reduction: the latter being also the name of a well-known arithmetical rule: a reducer is he who reduces: reducible, possible to be reduced: the noun substantive corresponding: reductive, having the power of reducing; something possessed of this power (see the second extract from Hale): the adverb corresponding.

They could not learn to digest that the man, which they had so long used to mask their own appetites, should now be the *reducer* of them into order. *Sidney.*

Abate the edge of traitors, gracious lord! That would *reduce* these bloody days again. *Shakspeare.*

The navy received blessing from Pope Sixtus, and was assigned as an apostolical mission for the *reduction* of this kingdom to the obedience of Rome. *Bacon.*

If they be our superiors, then 'tis modesty and reverence to all such in general, at least *reductively*. *Hammond.*

It were but just And equal to *reduce* me to my dust, Desirous to resign and render back All I received. *Milton.*

Under thee, as head supreme, Thrones, princedom, powers, dominions, I *reduce*. *Id.*

Left desert utmost hell, *Reduced* in careful watch round their metropolis. *Id.*

Some will have these years to be but months; but we have no certain evidence that they used to account a month a year; and, if we had, yet that *reduction* will not serve. *Hale.*

Thus far concerning these *reductives* by inundations and conflagrations. *Id. Origin of Mankind.*

Every thing visibly tended to the *reduction* of his sacred majesty, and all persons in their several stations began to make way and prepare for it. *Fell.*

A diaphanous body, *reduced* to very minute parts, thereby acquires many little surfaces in a narrow compass. *Boule.*

Spirits of wine, by its pungent taste, and especially by its *reducibility*, according to Helmont, into alkali and water, seems to be as well of a saline as a sulphureous nature. *Id.*

There is nothing so bad but a man may lay hold of something about it that will afford matter of excuse; nor nothing so excellent but a man may fasten upon something belonging to it whereby to *reduce* it. *Tillotson.*

Other niceties, though they are not matter of conscience, singly and apart, are yet so *reductively*; that is, though they are not so in the abstract, they become so by affinity and connection. *L'Estrange.*

The ordinary smallest measure is looked on as an unit in number, when the mind by division would reduce them into less fractions. *Locke.*

Actions that promote society and mutual fellowship, seem reducible to a proneness to do good to others, and a ready sense of any good done by others. *South.*

The most prudent part was his moderation and indulgence, not reducing them to desperation. *Arbuthnot on Coins.*

REDUCTION OF EQUATIONS, in algebra, is the clearing them from all superfluous quantities, bringing them to their lowest terms, and separating the known from the unknown, till at length only the unknown quantity is found on one side, and known ones on the other. The reduction of an equation is the last part of the resolution of the problem. See ALGEBRA.

REDUNDANT, *adj.* Lat. *redundans.* Superabundant; exuberant; superfluous.

The cause of generation seemeth to be fulness; for generation is from *redundancy*: this fulness ariseth from the nature of the creature, if it be hot, and moist and sanguine; or from plenty of food. *Bacon.*

His head,  
With burnished neck of verdant gold, erect  
Amidst his circling spires, that on the grass  
Floated *redundant.* *Milton's Paradise Lost.*

I shall show our poet's *redundance* of wit, justness of comparisons, and elegance of descriptions. *Garth.*

Labour ferments the humours, casts them into their proper channels, and throws off *redundancies.* *Addison.*

Where the author is *redundant*, mark those paragraphs to be retrenched; when he trifles, abandon those passages. *Watts.*

REDUPLICATE, *v. a.* } Re and duplicate.  
REDUPLICATION, *n. s.* } To double: the act  
REDUPLICATIVE, *adj.* } of doubling: double.

This is evident when the mark of exclusion is put; as when we speak of a white thing, adding the *reduPLICATION*, as white; which excludes all other considerations. *Digby.*

Some logicians mention *reduuplicative* propositions; as men, considered as men, are rational creatures; i. e. because they are men. *Watts's Logick.*

RED-WING. See TURDUS.

REE, *v. a.* Belg. *ree, rede.* To riddle; sift. After malt is well rubbed and winnowed, you must then *ree* it over in a sieve. *Mortimer's Husbandry.*

REECHO, *v. n.* Re and echo. To echo back.

Around we stand, a melancholy train,  
And a loud groan *reechoes* from the main. *Pope.*

REECHY, *adj.* Corruptly formed from REEK, which see. Smoky; sooty; tanned by smoke.

Let him, for a pair of *reechy* kisses,  
Make you to ravel all this matter out. *Shakspeare.*

The kitchen malkin pins  
Her richest lockram 'bout her *reechy* neck. *Id.*

REED, *n. s.* } Sax. *neod*; Belg. *ried*;  
REED'ED, *adj.* } Teut. *riet.* A hollow knotted  
REED'EN, } stalk or cane which grows in  
REED'Y. } wet grounds: hence a small  
pipe or arrow: reeded, reeden, and reedy, mean consisting of, or covered with, reeds.

Where houses be *reeded*,  
Now pare off the moss, and go beat in the *reed.* *Tussor.*

Youths toomed before their parents were,  
Whom foul Cocytus' *reedless* banks enclose. *May.*  
I'll speak between the change of man and boy  
With a *reed* voice. *Shakspeare.*

Arcadian pipe, the pastoral *reed*  
Of Hermes. *Milton.*  
The knotty bulrush next in order stood,  
And all within of *reeds* a trembling wood. *Dryden.*

Honey in the sickly hive infuse  
Through *reeded* pipes. *Id. Virgil's Georgicks.*  
When the Parthian turned his steed,  
And from the hostile camp withdrew;  
With cruel skill the backward *reed*  
He sent; and as he fled, he flew. *Prior.*  
The' adjoining brook, now fretting o'er a rock,  
Now scarcely moving through a *reedy* pool. *Thomson.*

REED, in botany. See ARUNDO and BAMBOO. There are two sorts of reeds, says Hasselquist, growing near the Nile. One of them has scarcely any branches; but is furnished with numerous leaves, which are narrow, smooth, channelled on the upper surface; and the plant is about eleven feet high. The Egyptians make ropes of the leaves. They lay them in water like hemp, and then make them into good strong cables. These, with the bark of the date trees, form almost the only cable used in the Nile. The other sort is a small reed, about two or three feet high, full-branched, with short, sharp, lancet-shaped leaves. The roots, which are thick at the stem, creep and mat themselves together to a considerable distance.

REED, a term in the west of England for the straw used by thatchers, which is wheat straw finely combed, consisting of stiff, unbruised, and unbroken stalks of great length, carefully separated from the straw used for fodder by the thrasher, and bound in sheaves or nitches, each of which weighs twenty-eight pounds, and are sold from 21s. to 31s. per hundred nitches according to the season.

REED (Isaac), a late ingenious English critic, was a native of London, and born in 1742. He was educated for the law, and in the earlier part of his life practised as a conveyancer, but eventually gave himself up entirely to the cultivation of general literature, and was the author of a History of the English Stage, prefixed to his edition of the Biographia Dramatica; the Repository, a collection of humorous and miscellaneous pieces, 4 vols. 1783; besides superintending the publication of lady Mary Wortley Montagu's poetical effusions, and an improved edition of Dodsley's Old Plays. He is, however, most advantageously known as superintending splendid editions of Shakspeare, in 10 and subsequently in 21 vols. 8vo., of which the latter is considered the most perfect extant. As a book collector, also, he displayed considerable judgment, and had amassed a library of classical and miscellaneous literature inferior to few private ones. It occupied thirty-nine days in its disposal by public auction on his death. In addition to these literary labors, the miscellany known by the name of the European Magazine, of which he was

partly the owner, was for many years carried on by him. His death took place in the commencement of 1807.

REED-GRASS. See ARUNDO.

REED'IFY, *v. a.* Fr. *reedifier*, re and edify. To rebuild; build again.

The Æolians, who re-peopled, *reedified* Ilium.  
*Sandys.*

The ruined walls he did *reedify*. *Spenser.*

This monument five hundred years hath stood,  
Which I have sumptuously *reedified*. *Shakspeare.*

REEF, in nautical affairs, a certain portion of a sail, comprehended between the top or bottom, and a row of eyelet holes parallel thereto. The intention of the reef is to reduce the surface of the sail in proportion to the increase of the wind; for which reason there are several reefs parallel to each other in the superior sails, whereby they may be still farther diminished, in order to correspond with the several degrees of the gale. Thus the top-sails of ships are usually furnished with four reefs, and there are always three or four reefs, parallel to the bottom on those main-sails and fore sails, which are extended upon booms. The topsails are always, and the courses generally, reefed with points, which are flat braided pieces of cordage, whose lengths are nearly double the circumference of the yard. These, being inserted in the eyelet-holes, are fixed in the sail by means of two knots in the middle. In order to reef the top-sails with more facility and expedition, they are lowered down and made to shiver in the wind; the extremities of the reef are then drawn up to the yard arms by the reef-tackle, where they are securely fastened by the earings. The space of sail comprehended in the reef is then laid smoothly over the yard, in several folds, and the whole is completed by tying the points about the yard, so as to bind the reef close up to it.

In reefing a course, the after end of the point should be thrust forward between the head of the sail and the yard; and the fore end of the same point should come aft over the head of the sail, and also under the yard; and, thus crossed over the head of the sail, the two ends should be tied on the upper side of the yard as tight as possible. When a sail is reefed at the bottom, it is generally done with knittles in the room of points; or in large sails, such as the mainsails of cutters, pieces of line termed reef hanks are fixed in the eyelet holes.

Captain Malcolm Cowan, R. N. made an improvement both in the construction and the reefing of sails, which renders the operation of reefing the courses more easy and expeditious, with a less number of men than the old method requires.

REEF is also a name given to the perpendicular banks of coral so often met with in the South Seas.

REEK, *n. s.* } Sax. *reke*; Belg. *reuke*; Teut.

REEK'Y. } *rauch*. Smoke; steam; vapor: reeky is smoky; tanned.

'Tis as hateful to me as the reek of a lime kiln.

*Shakspeare.*

Dying like men, though buried in your dunghills,

They shall be famed, for there the sun shall greet them,

And draw their honours *reeking* up to heaven. *Id.*

Shut me in a charnel house,  
O'ercovered quite with dead men's rattling bones,  
With *reeky* shanks and yellow chapless skulla. *Id.*

I found me laid

In balmy sweat; which with his beams the sun  
Soon dried, and on the *reeking* moisture fed.

*Milton.*

Nor barns at home, nor *reeks* are reared abroad.

*Dryden.*

The covered *reek*, much in use westward, must needs prove of great advantage in wet harvests.

*Mortimer.*

Love one descended from a race of tyrants,  
Whose blood yet *reeks* on my avenging sword.

*Smith.*

REEL, *v. n., v. a., & n. s.* Sax. *neol*; Isl. *rala*; Swed. *rasla*; Scot. *rele*. To roll; stagger; roll in walking: as a verb active, take yarn off the spindle: a turning frame, upon which yarn is wound into skeins from the spindle.

They *reel* to and fro, and stagger like a drunken man.

*Palms.*

Grope in the dark, and to no seat confine  
Their wandering feet, and *reel* as drunk with wine.

*Sandys.*

Him when his mistress proud perceived to fall,  
While yet his feeble feet for faintness *reeled*,  
She 'gan call, help Orgoglio!

*Spenser.*

What news in 'this our tottering state?

—It is a *reeling* world,

And I believe will never stand upright.

I'll Richard wear the garland. *Shakspeare*

It is amiss to sit

And keep the turn of tipling with a slave,  
To *reel* the streets at noon.

*Id.*

It may be useful for the *reeling* of yarn. *Wilkins.*

He with heavy fumes oppress,

*Reeled* from the palace, and retired to rest. *Pope.*

Should he hide his face,

The' extinguished stars would loosening *reel*

Wide from their spheres. *Thomson.*

My heart turned sick, my brain grew sore,

And throbb'd awhile, then beat no more:

The skies spun like a mighty wheel;

I saw the trees like drunkards *reel*. *Byron.*

REELECTION, *n. s.* Re and election. Repeated election.

Several acts have been made, and rendered ineffectual, by leaving the power of *reelection* open.

*Swift.*

REELING, in the manufactories, the winding of silk cotton, &c. into a skain, or upon a button, to prevent its entangling. It is also used for the charging or discharging of bobbins, or quills, to use them in the manufacture of different stuffs, as thread, silk, cotton, &c.

REENACT', *v. a.* Re and enact. To enact anew.

The construction of ships was forbidden to senators, by a law made by Claudius the tribune, and *reenacted* by the Julian law of concessions.

*Arbutnot.*

REENFORCE', *v. a.* Re and enforce. To strengthen with new assistance or support.

The French have *reinforced* their scattered men.

*Shakspeare.*

Alone he entered

The mortal gate o' the city, which he painted



With shunless destiny; aidless came off.  
And with a sudden reenforcement struck  
Corioli like a planet. *Id. Coriolanus.*  
They used the stones to reenforce the pier.  
*Hayward.*

What reenforcement we may gain from hope.  
*Milton.*

The presence of a friend raises fancy, and reen-  
forces reason. *Collier.*

The words are a reiteration or reenforcement of a  
corollary. *Ward.*

REENJOY', *v. a.* Re and enjoy. To enjoy  
anew or a second time.

The calmness of temper Achilles reenjoyed is  
only an effect of the revenge which ought to have  
preceded. *Pope.*

REENTER, *v. a.* Re and enter. To enter  
again; to enter anew.

With opportune excursion, we may chance  
Reenter heaven. *Milton.*

The fiery sulphureous vapours seek the centre from  
whence they proceed; that is, reenter again.  
*Mortimer's Husbandry.*

REENTHRONE', *v. a.* To replace in a  
throne.

He disposes in my hands the scheme  
To reenthrone the king. *Southern.*

REENTRANCE, *n. s.* Re and entrance.  
The act of entering again.

Their repentance, although not their first entrance,  
is notwithstanding the first step of their reentrance  
into life. *Hooker.*

The pores of the brain, through the which the spi-  
rits before took their course, are more easily opened  
to the spirits which demand reentrance.  
*Glanville's Scepis.*

REEPHAM, a parish and market town of Nor-  
folk seated on the river Eyne, thirteen miles north-  
west from Norwich, and 113 north by east from  
London. It is remarkable for having had an-  
ciently three churches, one in Reepham, another  
in Whitwell, and another in Hacton, two villages  
adjoining, all in one church-yard; the two for-  
mer were long ago demolished, and the latter was  
burnt down, together with the greater part of the  
town, about the year 1500. The chief trade of  
this little town is in malt, and the market is held  
on Saturday.

REES (Abraham), D.D., F.R.S., and F.L.S. a  
late dissenting clergyman of distinguished literary  
and scientific rank, was the son of a nonconformist  
minister of the principality, and was born at, or in  
the neighbourhood of, Montgomery, in 1743. He  
was first placed under Dr. Jenkins of Carmarthen,  
and afterwards at the Hoxton Academy founded  
by Mr. Coward, where his progress was so rapid  
that in his nineteenth year he was appointed  
mathematical tutor to the institution, and soon  
after resident tutor, in which capacity he con-  
tinued upwards of twenty-two years. In 1768  
he became pastor of the presbyterian congrega-  
tion of St. Thomas's Southwark, and continued  
in that situation till 1783, when he accepted an  
invitation to become minister of a congregation  
in the Old Jewry, with which he remained till his  
death. On the establishment of the New Dis-  
senting College at Hackney, in 1786, Dr. Rees,  
who had seceded from Hoxton two years before,  
was elected to the situation of resident tutor in  
the natural sciences, which he held till the dis-

solution of the academy, on the death of Dr.  
Kippis. But Dr. Rees, though esteemed through-  
out his long life, as an able and learned Arian  
divine, was principally and most advantageously  
known in his literary capacity. In 1776 he was  
applied to by the proprietors of Chambers's  
Cyclopædia as the person best qualified to super-  
intend a new and enlarged edition of that compila-  
tion, which, after nine years' labor, he completed  
in four folio volumes. After this the proprietors  
and our author projected a much improved  
edition; and he had the satisfaction to see the  
Cyclopædia, now generally known by his name,  
proceed with credit from the publication of its first  
volume in 1802 to its completion in forty-five  
volumes, 4to. His other works are, *Economy*  
*Illustrated and Recommended*, 1800; *Antidote*  
*to the Alarm of Invasion*, 1805; *Practical Ser-*  
*mons*, 2 vols. 8vo., 1809—1812; *The Principles*  
*of Protestant Dissenters stated and vindicated*;  
and a variety of occasional Sermons. Dr. Rees,  
we are told, obtained his diploma from the uni-  
versity of Edinburgh at the express recommen-  
dation of Dr. Robertson the historian. His  
death took place June 9th, 1825.

REESTABLISH, *v. a.* Re and establish.  
To establish anew.

To reestablish the right of lineal succession to pa-  
ternal government is to put a man in possession of  
that government which his fathers did enjoy. *Locke.*

Peace, which hath for many years been banished  
the christian world, will be speedily reestablished.  
*Smalridge.*

The Jews made such a powerful effort for their  
reestablishment under Barchocab, in the reign of  
Adrian, as shook the whole Roman empire.  
*Addison.*

REEVE, *n. s.* Sax. *gerefa*. A steward.  
Obsolete.

The reeve, miller, and cook, are distinguished.  
*Dryden.*

REEVE (Clara), an ingenious modern autho-  
ress, was born at Ipswich in 1738. She pos-  
sessed considerable learning, which she displayed  
in a translation of Barclay's Latin Romance of  
Argenis, published under the title of the Phœnix,  
or the History of Polyarchus and Argenis, 4 vols.  
12mo., 1772; and the Progress of Romance.  
Her other works are, *The Old English Baron*;  
*The Two Mentors*, a modern Story; *The Exile*;  
*The School for Widows*; *A Plan of Education*,  
and *Memoirs of Sir Roger de Clarendon*, 4 vols.  
She died at Ipswich in 1806.

REEXAM'INE, *v. a.* Re and examine. To  
examine anew.

Spend the time in reexamining more duly your  
cause. *Hooker.*

RE-EXCHANGE, in commerce, a second  
payment of the price of exchange, or rather the  
price of a new exchange due upon a bill of ex-  
change that is protested, and refunded the bearer  
by the drawer or indorser.

REFECT, *v. a.* } Lat. *refectus*. To re-  
REFECTORY, *n. s.* } fresh; to restore after  
hunger or fatigue: an eating-room. Not in use.

A man in the morning is lighter in the scale. be-  
cause in sleep some pounds have perspired; and is  
also lighter unto himself, because he is refected.

*Broune's Vulgar Errors.*

After a draught of wine, a man may seem lighter in himself from sudden *refection*, though he be heavier in the balance, from a ponderous addition.

*Browne.*

He cells and *refectories* did prepare.  
And large provisions laid of winter fare.

*Dryden.*

Fasting is the diet of angels, the food and *refection* of souls, and the richest aliment of grace.

*South.*

For sweet *refection* due,  
The genial viands let my train renew.

*Pope.*

REFECTION, among ecclesiastics, is a spare meal or repast, for the support of life: hence the hall in convents, and other communities, where the monks, nuns, &c., take their refectious or meals in common, is called the refectory.

REFEL', *v. a.* Lat. *refello*. To refute; to repress.

Friends, not to *refel* ye  
Or any way quell ye,  
Ye aim at a mystery,

Worthy a history. *Ben Jonson's Gypsies.*

It instructs the scholar in the various methods of discovering and *refelling* the subtle tricks of sophisters.

*Watts.*

REFER', *v. a. & v. n.* Fr. *referer*; Lat. REFEREE', *n. s.* } *refero*. To send for REFERENCE, } information or decision; REFERENDARY. } on; reduce to a class REFER'RIBLE, *adj.* } or end; as a verb-neuter, to respect; appeal: a referee is one to whom reference is made: as also is (obsolete) referendary; reference is dismissal or deference to another tribunal; relation; respect: referrible, capable of reference.

The knowledge of that which man is in *reference* unto himself, and other things in relation unto man, I may term the mother of all those principles which are decrees in that law of nature, whereby human actions are framed.

*Hooker.*

The heir of his kingdom hath *referred* herself unto a poor but worthy gentleman.

*Shakespeare.*

Jupiter was the son of *Æther* and *Dies*; so called, because the one had *reference* to his celestial conditions, the other discovered his natural virtues.

*Raleigh's History of the World.*

You profess and practise to *refer* all things to yourself.

*Bacon.*

In suits it is good to *refer* to some friend of trust; but let him chuse well his *referendaries*.

*Bacon's Essays.*

Unto God all parts of mine are alike, unto whom none are more *referrible*, and all things present, unto whom nothing is past or to come, but who is the same yesterday, to-day, and to-morrow.

*Browne.*

The salts, predominant in quicklime, we *refer* rather to lixiviate, than acid.

*Boyle on Colours.*

Christian religion commands sobriety, temperance, and moderation, in *reference* to our appetites and passions.

*Tillotson.*

*Referees* and arbitrators seldom forget themselves.

*L'Estrange.*

Of those places that *refer* to the shutting and opening the abyss, I take notice of that in Job.

*Burnet.*

It passed in England without the least *reference* hither.

*Swift.*

REFERMENT', *v. a.* Re and ferment. To ferment anew.

The' admitted nitre agitates the flood,  
Revives its fires, and *referments* the blood.

*Blackmore.*

REFINE', *v. a. & v. n.* } Fr. *raffiner*. To  
REFINEDLY, *adv.* } purify; clear;  
REFINEMENT, *n. s.* } make subtle, ele-  
REFINER. } gant, or accurate:

as a verb neuter, to improve in accuracy or delicacy; grow pure; affect nicety or scrupulousness: the adverb and noun substantives corresponding.

I will *refine* them as silver is *refined*, and will try them as gold is tried.

*Zechariah xiii. 9.*

The *refiners* of iron observe that that iron stone is hardest to melt which is fullest of metal; and that easiest which has most dross.

*Bacon.*

Queen Elizabeth's time was a golden age for a world of *refined* wits, who honoured poesy with their pens.

*Peacham.*

Love *refines* the thought, and hath his seat  
In reason.

*Milton.*

Chaucer *refined* on Boccace, and mended his stories.

*Dryden.*

Will any dog

*Refinedly* leave his bitches and his bones

To turn a wheel?

*Id.*

The red Dutch currant yields a rich juice to be diluted with a quantity of water boiled with *refined* sugar.

*Mortimer.*

The more bodies are of kin to spirit in subtlety and *refinement*, the more diffusive are they.

*Norris.*

The pure limpid stream, when foul with stains,

Works itself clear, and as it runs *refines*.

*Addison.*

The firts about town had a design to leave us in the lurch, by some of their late *refinements*.

*Id.*

No men see less of the truth of things, than these great *refiners* upon incidents, who are so wonderfully subtle, and over-wise in their conceptions.

*Id. Spectator.*

The rules religion prescribes are more successful in public and private affairs than the *refinements* of irregular cunning.

*Rogers.*

He makes another paragraph about our *refining* in controversy, and coming nearer still to the church of Rome.

*Atterbury.*

Let a lord but own the happy lines;

How the wit brightens, how the sense *refines*!

*Pope.*

The same traditional sloth which renders the bodies of children, born from wealthy parents, weak, may perhaps *refine* their spirits.

*Swift.*

From the civil war to this time, I doubt whether the corruptions in our language have not equalled its *refinements*.

*Id.*

Some *refiners* pretend to argue for the usefulness of parties upon such a government as ours.

*Id.*

The religion of the gospel is only the *refinement* and exaltation of our best faculties.

*Lau.*

She judges of *refinement* by the eye,

He by the test of conscience, and a heart

Not soon deceived; aware that what is base

No polish can make sterling.

*Cowper.*

REFINING, in metallurgy, is the purifying metals from any accidental alloys with which they may be mixed.

Gold, having the property which no other metal has of resisting the action of sulphur, antimony, nitrous acid, and muriatic acid, may be purified by these agents from all other metallic substances.

These operations are distinguished by proper names, as purification of gold by antimony, parting, concentrated parting, dry parting. See ASSAYING and PARTING.

As silver has also the property, which the less valuable metals have not, of resisting the action of nitre, it may be refined by this salt: but the term *refining* is chiefly applied to the purification of

2 1'

gold and silver by lead in the cupel. This is performed by the destruction, vitrification, and scorification, of all the extraneous and destructible metallic substances with which they are alloyed. As gold and silver alone can resist the combined action of air and fire, there is a possibility of purifying gold and silver from all alloy of the other metals merely by the action of fire and air; only by keeping them fused till all the alloy be destroyed; but this purification would be very tedious and expensive, from the great consumption of fuel. Silver alloyed with copper has been exposed above sixty hours to a glass-house fire without being perfectly refined: the reason is, that, when a small quantity only of other metal remains united with gold or silver, it is protected from the action of the air, which is necessary for its combustion. This refining of gold and silver merely by the action of fire, which was the only method anciently known, was very tedious, difficult, expensive, and imperfect; but a much shorter and more advantageous method has been long practised. This consists in adding to the alloyed gold and silver a certain quantity of lead, and in exposing this mixture to the action of fire. The vessel in which the refining is performed is hollowed, but shallow, that the matter which it contains may present to the air the greatest surface possible. This form resembles that of a cup, and hence it is called a cupel. The surface ought to be vaulted, that the heat may be applied upon the surface of the metal during the whole time of the operation. Upon this surface a crust of dark colored pellicle is continually forming. In the instant when all the other metals are destroyed, the surface of the gold and silver is seen, and appears clean and brilliant. By this mark the metal is known to be refined. If the operation be so conducted that the metal sustains only the precise degree of heat necessary to keep it fused before it be perfectly refined, it fixes or becomes solid all at once in the very instant of the coruscation; because a greater heat is required to keep gold or silver in fusion when they are pure than when alloyed with lead. The operation of refining may be performed in small or in large quantities, upon the same principles, but only with some differences in the management. As the refining of small quantities of gold and silver is performed in the same manner as these metals are assayed, the assay being only a very accurate refining, we refer to the articles ASSAYING and METALLURGY.

REFIT', *v. a.* Fr. *refait*. Re and fit. To repair; to restore after damage.

Permit our ships a shelter on your shores,  
*Refitted* from your woods with planks and oars.

*Dryden.*

He will not allow that there are any such signs of art in the make of the present globe, or that there was so great care taken in the *refitting* of it up again at the deluge.

*Woodward.*

REFLECT *v. a. & v. n.* Lat. *reflecto*. To  
REFLECT'ENT, *adj.* } throw or bend back;  
REFLECTION, *n. s.* } throw back light;  
REFLECTIVE, *adj.* } bend back; throw  
REFLECTOR, *n. s.* } back thought; con-  
sider; throw reproach or censure: reflectent is

bending or flying back; reproachful: reflection, the act of reflecting in any way; that which is reflected; consideration; censure: reflective, throwing back; applied both to literal images and thought: reflector, he who reflects or considers.

In dead men's skulls, and in those holes,  
Where eyes did once inhabit, there were crept,  
As 'twere in scorn of eyes, *reflecting* gems.

*Shakspeare.*

The eye sees not itself,

But by *reflection* from other things.

*Id.*

She shines not upon fools, lest the *reflection* should hurt her.

*Id.*

We, his gathered beams

*Reflected*, may with matter sere foment.

*Milton.*

The imagination casts thoughts in our way, and forces the understanding to *reflect* upon them.

*Duppa.*

The ray descendant, and the ray *reflectent*, flying with so great a speed that the air between them cannot take a formal play any way, before the beams of the light be on both sides of it; it follows, that, according to the nature of humid things, it must first only swell.

*Digby on the Soul.*

In every action *reflect* upon the end; and, in your undertaking it, consider why you do it.

*Taylor.*

Who saith, who could such ill events expect?

With shame on his own counsels doth *reflect*.

*Denham.*

The three first parts I dedicate to my old friends, to take off those melancholy *reflections* which the sense of age, infirmity, and death may give them.

*Id.*

There is scarce any thing that nature has made, or that men do suffer, whence the devout *reflector* cannot take an occasion of an aspiring meditation.

*Boyle on Colours.*

Bodies close together *reflect* their own colour.

*Dryden.*

Errors of wives *reflect* on husbands still.

*Id.*

This dreadful image so possessed her mind,

She ceased all farther hope; and now began

To make *reflection* on the unhappy man.

*Id.*

When the weary king gave place to night,

His beams he to his royal brother lent,

And so shone still in his *reflective* light.

*Id.*

When men are grown up, and *reflect* on their own minds, they cannot find any thing more ancient there than those opinions which were taught them before their memory began to keep a register of their actions.

*Locke.*

*Reflection* is the perception of the operations of our own minds within us, as it is employed about the ideas it has got.

*Id.*

This delight grows and improves under thought and *reflection*; and, while it exercises, does also endear itself to the mind; at the same time employing and inflaming the meditations.

*South's Sermons.*

It is hard that any part of my land should be settled upon one who has used me so ill; and yet I could not see a sprig of any bough of this whole walk of trees, but I should *reflect* upon her and her severity.

*Addison's Spectator*

Into myself my reason's eye I turned;

And, as I much *reflected*, much I mourned.

*Prior.*

He died; and oh! may no *reflection* shed

Its poisonous venom on the royal dead.

*Id.*

In the *reflective* stream the sighing bride,

Viewing her charms impaired, abashed shall hide

Her pensive head.

*Id.*

Inanimate matter moves always in a straight line, and never *reflects* in an angle, nor bends in a circle, which is a continual *reflection*, unless either by some

external impulse, or by an intrinsic principle of gravity.

*Bentley's Sermons.*

What wounding reproaches of soul must he feel, from the *reflections* on his own ingratitude. *Rogers.*

Job's *reflections* on his once flourishing estate did at the same time afflict and encourage him.

*Atterbury.*

If the sun's light consisted but of one sort of rays, there would be but one colour, and it would be impossible to produce any new by *reflections* or *refractions*.

*Cheune.*

Neither do I *reflect* in the least upon the memory of his late majesty, whom I entirely acquit of any imputation.

*Swift.*

REFLECTING TELESCOPES. See OPTICS and TELESCOPES.

REFLECTION OF LIGHT. See OPTICS.

REFLECTING CIRCLE, an instrument for measuring angles to a very great degree of accuracy. It was invented by Mayer of Gottingen, principally with a view to do away the errors of the divisions of the limb; and has since been much improved by the Chevalier de Borda, and M. J. H. de Magellan. See NAVIGATION.

REFLEX, *adj. & n. s.*

Lat. *reflexus.*

REFLEXIBILITY, *n. s.*

Backward; back-

REFLEXIBLE, *adj.*

ward direction:

REFLEXIVE, *adj.*

reflexibility is the

REFLEXIVELY, *adv.*

quality of being

reflexible; capable of being thrown back: reflexive, thrown backwards: the adverb corresponding.

There was no other way for angels to sin, but by *reflex* of their understandings upon themselves.

*Hooker.*

I'll say you gray is not the morning's eye,

'Tis but the pale *reflex* of Cynthia's brow.

*Shakspeare.*

That assurance *reflexive* cannot be a divine faith, but at the most an human, yet such as perhaps I may have no doubting mixed with.

*Hammond.*

The motions of my mind are as obvious to the *reflex* act of the soul, or the turning of the intellectual eye inward upon its own actions, as the passions of my sense are obvious to my sense; I see the object, and I perceive that I see it.

*Hale.*

Solomon tells us life and death are in the power of the tongue, and that not only directly in regard of the good or ill we may do to others, but *reflexively* also in respect of what may rebound to ourselves.

*Government of the Tongue.*

*Reflexibility* of rays is their disposition to be reflected or turned back into the same medium from any other medium, upon whose surface they fall; and rays are more or less *reflexible* which are turned back more or less easily.

*Newton.*

The order and beauty of the inanimate parts of the world, the discernible ends of them, do evince by a *reflex* argument that it is the workmanship, not of blind mechanism or blinder chance, but of an intelligent and benign agent.

*Bentley.*

Sir Isaac Newton has demonstrated, by convincing experiments, that the light of the sun consists of rays differently refrangible and *reflexible*; and that those rays are differently *reflexible* that are differently refrangible.

*Cheyne.*

REFLOAT, *n. s.* Re and float. Ebb; reflux.

The main float and *refloat* of the sea is by consent of the universe, as part of the diurnal motion.

*Bacon.*

REFLOURISH, *v. a.* Re and flourish. To flourish anew.

Virtue given for lost

Revives, *reflourishes*, then vigorous most,  
When most unactive deemed. *Milton's Agonistes.*

REFLUENT, *adj.* Lat. *refluens.* Running back; flowing back.

Tell, by what paths,

Back to the fountain's head the sea conveys

The *refluent* rivers, and the land repays. *Blackmore.*

The liver receives the *refluent* blood almost from all parts of the abdomen.

*Arbuthnot.*

REFLUX, *n. s.* Fr. *reflux*; Lat. *refluxus.* Backward course.

Besides

Mine own that bide upon me, all from me

Shall with a fierce *reflux* on me redound. *Milton.*

The variety of the flux and *reflux* of Euripus, or whether the same do ebb and flow seven times a day, is incontrovertible.

*Broune.*

REFORM, *v. a. & v. n.* } Fr. *reformer*;  
REFORMATION, *n. s.* } Lat. *reformatio*. T  
REFORMER. } form on a better

model; change from worse to better: reformation is the act of so changing; applied particularly to the religious change of several European nations from popery in the sixteenth century: a reformer is one who effects a beneficial change of things or persons; one who particularly promoted the Protestant Reformation.

A sect in England, following the very same rule of policy, seeketh to *reform* even the French *reformation*, and purge out from thence all dregs of popery.

*Hooker.*

Never came *reformation* in a flood  
With such a heady current, scowering faults;  
Nor ever Hydra-headed wilfulness  
So soon did lose his seat, as in this king.

*Shakspeare.*

Our first *reformers* were famous confessors and martyrs all over the world.

*Bacon.*

Public *reformers* had need first practise that on their own hearts which they purpose to try on others.

*King Charles.*

May no such storm

Fall on our times, where ruin must *reform*.

*Denham.*

Seat worthier of Gods was built

With second thoughts, *reforming* what was old.

*Milton.*

Now lowering looks presage approaching storms,  
And now prevailing love her face *reforms*.

*Dryden.*

Satire lavishes vice into *reformation*.

*Id.*

One cannot attempt the perfect *reforming* the languages of the world, without rendering himself ridiculous.

*Locke.*

The complaint is more general than the endeavours to redress it: abroad every man would be a *reformer*, how very few at home!

*Sprat.*

It was honour enough to behold the English churches *reformed*; that is, delivered from the *reformers*.

*South.*

The pagan converts mention this great *reformation* of those who had been the greatest sinners, with that sudden and surprising change which the Christian religion made in the lives of the most profligate.

*Addison.*

Was his doctrine of the mass struck out in this conflict? or did it give him occasion of *reforming* in this point?

*Atterbury.*

The burden of the *reformation* lay on Luther's shoulders.

*Atterbury.*

The example alone of a vicious prince will corrupt an age; but that of a good one will not *reform* it.

*Swift.*

## R E F O R M A T I O N .

**REFORMATION.** Amid the corruptions of the Christian church, from its first aberration from the simplicity of the gospel down to the council of Trent, there have ever been those who exhibited 'the faith and patience of the saints:' and to these persons, who amid persecution, and contempt, and neglect, were indeed the salt of the earth, we are indebted, under God, for those efforts which, after many conflicts and trials, terminated in the reformation of the Christian profession in the sixteenth century; and divested it of that gorgeousness, extravagance, and ceremonial formality, by which its purity and spirituality had been long obscured, and well nigh obliterated. The conflicts between truth and error, light and darkness, had endured, with more or less of violence and alternate success, from the time of Paulinus of Apulia to that of Wickliff; and thence down to those of the great Luther. It is true the powers of ignorance and of a corrupt religion held the minds of mankind in the deepest thralldom; and few, comparatively, were those who felt their moral degradation, and sighed after a holier and a more pure faith: yet were these few 'valiant for the truth,' 'not counting their lives dear unto themselves.' Of these many who adhered to the gospel, and remained uncorrupted amidst the growth of superstition; who deplored the miserable state to which Christianity was reduced by the alteration of its divine doctrines, and the vices of its profligate ministers; opposed with vigor the tyrannical ambition both of the lordly pontiff and the aspiring bishops; and in some provinces privately, in others openly, attempted the reformation of a corrupt and idolatrous church, and of a barbarous and superstitious age. This was, indeed, bearing witness to the truth in the noblest manner.

Before, however, we enter on a review of the various attempts which were thus made to correct the abuses of the Roman church, it will be necessary to take a survey of its actual state, at the period to which we refer. That authority, to which the church could lay no claim for the purity of its members, was supported by its arrogant pretensions; availing itself of all notions, accidents, practices, and frauds, from which any advantage could be derived, till the whole monstrous accumulation assumed a coherent form, which well deserves to be called 'the mystery of iniquity.' The scriptures, even in the Latin version, had long become a sealed book to the people: and the Roman see, in proportion as it extended its supremacy, discouraged or proscribed the use of such vernacular versions as existed. This it did, not lest the ignorant and half-informed should mistake the sense of Scripture, nor lest the presumptuous and the perverse should deduce new errors in doctrine, and more fatal consequences in practice, from its distorted language; but in the secret and sure consciousness that what was now taught as Christianity was not to be found in the written word of God. In maintenance of the dominant system, tradition,

or the unwritten word, was set up. This had been the artifice of the earliest heretics, who, when they were charged with holding doctrines not according to scripture, affirmed that some things had been revealed which were not committed to writing, but were orally transmitted. The pharisees before them pleaded the same supposititious authority for the formalities which they superadded to the law, and by which they sometimes superseded it, 'making the word of God of none effect,' as our Saviour himself reproached them; upon this ground the Romish clergy justified all the devices of man's imagination with which they had corrupted the ritual and the faith of the western churches.

At one time relics, or entire bodies, used to be carried about the country and exhibited to the credulous multitude; but this gainful practice gave occasion to such scandalous impostures that it was at length suppressed; but what is still encouraged is sufficiently disgraceful to the Romanists.

*I. State of the Romish church.*—A review of the then existing state of the Romish faith and practice will, at once, justify the efforts of those who sought to reform their abuses and restore the purity of its doctrine and discipline. The bodies of the saints were, at times, exposed in their churches, some dried and shrivelled, others reduced to a skeleton, clothed either in religious habits or in the most gorgeous garments;—a spectacle as ghastly as the superstition itself is degrading! The poor fragments of mortality, a skull, a bone, or the fragment of a bone, or tooth, or a tongue, were either set or mounted, according to the size, in gold or silver; deposited in costliest shrines of the finest workmanship, and enriched with the most precious gems. Churches soon began to vie with each other in the number and variety of these imaginary treasures, which were sources of real wealth to their possessors: the instruments of our Lord's crucifixion were shown (the spear and the cross having, so it was pretended, been miraculously discovered); the clothes wherein he was wrapt in infancy; the manger in which he was laid; the vessels in which he converted water into wine at the marriage feast; the bread which he brake at the last supper; his vesture, for which the soldiers cast lots. Such was the impudence of Romish fraud, that portions were produced of the burning bush, of the manna which fell in the wilderness, of Moses's and Samson's honeycomb, of Tobit's fish, of the blessed Virgin's milk, and of our Saviour's blood! Enormous prices were paid by sovereigns for such relics; it was deemed excusable, not to covet merely, but to steal them; and if the thieves were sometimes miraculously punished they were quite as often enabled by miracle to effect the pious robbery, and bring the prize in triumph to the church for which it was designed. In the rivalry of deceit which the desire of gain occasioned, it often happened that the head of the same saint was

shown in several churches, each church insisting that its own was genuine, and all appealing to miracles as the test. Sometimes the dispute was accomplished in a more satisfactory manner, by asserting a miraculous multiplication, and three whole bodies of one person have been shown; the dead saint having tripled himself to terminate a dispute between three churches at his funeral! The catacombs at Rome were an inexhaustible mine of relics.

With the reverence which was paid to relics, arising thus naturally at first, and converted by crafty priests into a source of lucre, saint worship grew up. If such virtue resided in their earthly and perishable remains, how great must be the power wherewith their beatified spirits were invested in heaven! The Greeks and Romans attributed less to their demigods than the Catholic church has done to those of its members who have received their apotheosis. They were invoked as mediators between God and man; individuals claimed the peculiar protection of those whose names they had received in baptism; and towns, and kingdoms, chose each their tutelary saint. But, though every saint was able to avert all dangers and heal all maladies, each was supposed to exert his influence more particularly in some specific one, which was determined by the circumstances of his life or martyrdom, the accidental analogy of a name, or by chance and custom if these shadows of a cause were wanting. The virtue which they possessed they imparted to their images, in which, indeed, it was affirmed that they were really and potentially present, partaking of ubiquity in their beatitude. Church vied with church, and convent with convent, in the reputation of their wonder-working images, some of which were pretended to have been made without hands, and some to have descended from heaven! But the rivalry of the monastic orders was shown in the fictions wherewith they filled the histories of their respective founders and worthies. While the monastic orders contended with each other in exaggerating the fame of their deceased patriarchs, each claimed the Virgin Mary for its especial patroness. Some peculiar favor she had bestowed upon each; she had appointed their rule of life, or devised the pattern of their habits, or enjoined them some new practice of devotion, or granted them some singular privilege. She had espoused their founder with a ring, or fed him like a babe at her breast. All therefore united in elevating her to the highest rank in the mythology of the Romish church—for so, in strict truth, must this enormous system of fable be designated. They traced her in types throughout the Old Testament: She was the tree of life; the ladder which Jacob had seen leading from heaven to earth; the rod which brought forth buds and blossoms, and produced fruit; the ever burning bush; the ark of the covenant; the fleece upon which alone the dew of heaven descended. And though, indeed, being subject to death, she paid the common tribute of mortality; yet, having been born without sin, she expired without suffering, and her most holy body, too pure a thing to see corruption, was translated immediately to heaven, there to be glorified. Her image was to be found in every church through-

out Christendom; and she was worshipped under innumerable appellations, \* \* \* devotees believing that the one which they particularly affected was that to which the object of their adoration most willingly inclined her ear. By such representations and fables, the belief of the people became so entirely corrupted that Christ, instead of being regarded as our mediator and Redeemer, appeared to them in the character of a jealous God, whom it behoved them to propitiate through the mediation of his virgin mother; for through her alone could mercy and salvation be obtained. The pantheon, which Agrippa had dedicated to Jupiter and all the gods, was by the pope, who converted it into a church, inscribed to the blessed Virgin, and all the saints. The consequence of this persuasion brought into full view the weakness and strength of human nature; in some respects they degraded it below the beasts. The dearest and holiest ties of nature and society were set at nought by those who believed that the way to secure their own salvation was to take upon themselves the obligations of a monastic life. They regarded it as a merit to renounce all intercourse with their nearest friends and kin; and, being by profession dead to the world, rendered themselves, by a moral suicide, dead in reality to its duties and affections. For the sake of saving their own souls, or of attaining a higher seat in the kingdom of heaven, they sacrificed, without compunction, the feelings, and, as far as depended upon them, the welfare and happiness of a wife, parent, or child; yet when the conversion of others was to be promoted, these very persons, it is but justice to add, were ready to encounter any danger and to offer up their lives, not in doing good to others, but in inflicting the greatest possible quantity of discomfort and actual suffering upon themselves. It was deemed meritorious to disfigure the body by neglect and filth, to attenuate it by fasting and watchfulness, to lacerate it with stripes, and to fret the wounds with cilices of horse hair. Linen was proscribed among the monastic orders; and the use of the warm bath, which, being not less conducive to health than to cleanliness, had become general in all the Roman provinces, ceased throughout Christendom; because, according to the morality of the monastic school, cleanliness itself was a luxury, and to procure it by pleasurable means was a positive sin. There were some saints who never washed themselves, and made it a point of conscience never to disturb the vermin who were the proper accompaniments of such sanctity; in as far as they occasioned pain while burrowing; or, at pasture, were increasing the stock of the aspirant's merits. The act of eating they made an exercise of penance, by mingling whatever was most nauseous with their food. They bound chains round the body which ate into the flesh; or fastened graters upon the breast and back; or girded themselves with bandages of bristles intermixed with points of wire. Cases of horrid self-mutilation were sometimes discovered; and many perished by a painful and lingering suicide, believing that, in the torments which they inflicted upon themselves, they were offering an acceptable sacrifice to their Creator. Some became famous for the number of their daily ge-

reflections; others for immersing themselves to the neck in cold water during winter while they recited the psalter. Thus there was created a large and accumulating fund of good works, which, though supererogatory in the saints, were nevertheless not to be lost. The redemption which had been purchased for fallen man was held to be from external punishment only; sin was not, therefore, to go unpunished, even in repentant sinners who had confessed and received absolution. The souls of baptised children, it was held, passed immediately to heaven: but for all others, except the few who attained to eminent holiness in their lives, purgatory was prepared; a place, according to the popular belief, so near the region of everlasting torments, though separated from it, that the same fire pervaded both; acting indeed to a different end, and in different degrees, but even in its mildest effect inflicting sufferings more intense than heart could think or tongue express, and enduring for a length of time which was left fearfully indefinite. Happily for mankind, the authority of the pope extended over this dreadful place. The works of supererogation were at his disposal, and his treasure was inexhaustible, because it contained an immeasurable and infinite store derived from the atonement. One drop of the Redeemer's blood being sufficient to redeem the whole human race, the rest which had been shed during the passion was given as a legacy to be applied in mitigation of purgatory, as the popes in their wisdom might think fit. So they in their infallibility declared, and so the people believed! The popes were liberal of this treasure.

If they wished to promote a new practice of devotion, or encourage a particular shrine, they granted to those who should perform the one or visit the other an indulgence, that is a dispensation for so many years of purgatory; sometimes for shorter terms, but often by centuries, or thousands of years, and in many cases the indulgence was plenary—a toll ticket entitling the soul to pass scot free. All persons, however, could not perform pilgrimages; and even the accommodating device of the church, which promised large indulgences for saying certain prayers before the engraved portrait of a miraculous image, was liable in numerous instances to be frustrated. The picture might not find its way to remote places, the opportunity of acquiring it might be neglected, or it might remain in the possession of its unthinking owner, a forgotten thing. The Romish church, in its infinite benevolence, considered this, and therefore sold indulgences, making the act of purchasing them, and thus contributing to its wants, a merit of itself sufficient to deserve so inestimable a reward. It was taught, also, that merits were transferable by gift or purchase: under this persuasion large endowments were bestowed upon convents, on condition that the donor should partake in the merits of the community; and few persons, who had any property at their own disposal, went out of the world without bequeathing some of it to the clergy for saying masses, in number proportioned to the amount of the bequest, for the benefit of their souls. The wealthy founded chantries, in which service was to be performed

for ever, to this end. Thus were men taught to put their trust in riches; their wealth, being thus invested, became available to them beyond the grave; and in whatever sins they indulged, provided they went through the proper forms and obtained a discharge, they might purchase a free passage through purgatory, or, at least, an abbreviation of the term and a mitigation of its torments while they lasted. But purgatory was not the only invisible world over which the authority of the church extended; for to the pope, as to the representative of St. Peter, it was pretended that the keys of heaven and hell were given; a portion of this power was delegated to every priest, and they inculcated that the soul which departed without confession and absolution, bore with it the weight of its deadly sins to sink it to perdition.

Of all the practices of the Romish church this is the one which has proved most injurious to religion and morals; and, if it be regarded in connexion with the celibacy of the clergy, the cause will be apparent why the state of morals is generally so much more corrupt in Catholic than in Protestant countries. Tables were actually set forth, by authority, in which the rate of absolution for any imaginable crime was fixed, and the most atrocious might be committed with spiritual impunity for a few shillings. The church of Rome appears to have delighted in inting as well as in abusing human credulity, and to have pleased herself with discovering how far it was possible to subdue and degrade the human intellect, as an eastern despot measures his own greatness by the servile prostration of his subjects. If farther proof than has already appeared were needful, it would be found in the prodigious doctrine of transubstantiation. Strange as it may appear, the doctrine had become popular—with the people for its very extravagance—with the clergy because they grounded upon it their loftiest pretensions; for if there were in the sacrament this actual and entire sole presence, which they denoted by the term transubstantiation, it followed that divine worship was something more than a service of prayer and thanksgiving—an actual sacrifice was performed in it, wherein, they affirmed, the Saviour was again offered up, in the same body which had suffered on the cross, by their hands. The priest, when he performed this stupendous function of his ministry, had before his eyes, and held in his hands, the maker of heaven and earth; and the inference which they deduced from so blasphemous an assumption was, that the clergy were not to be subject to any secular authority, seeing that they could create God their Creator! Let it not be supposed that the statement is in the slightest part exaggerated: it is delivered faithfully in their own words. If, then, such were the power of the clergy, even of the meanest priest, what must be attributed to their earthly head, the successor of St. Peter? They claimed for him a plenitude of power; and it has been seen that he exercised it over the princes of Christendom in its fullest meaning. According to the canons the pope was as far above all kings as the sun is greater than the moon. He was king of kings and lord of lords, though he subscribed himself the servant of ser

vants. The immediate and sole rule of the whole world belonged to him, by natural, moral, and divine right; all authority depending upon him. As supreme king, he might impose taxes upon all Christians; and the popes declared it was to be held as a point necessary to salvation, that every human creature is subject to the Roman pontiff. That he might lawfully depose kings was averred to be so certain a doctrine that it could only be denied by madmen, or through the instigation of the devil; it was more pernicious and intolerable to deny it than to err concerning the sacraments. All nations and kingdoms were under the pope's jurisdiction; for to him had God delivered over the power and dominion in heaven and earth. Nay, he might take away kingdoms and empires, with or without cause, and give them to whom he pleased, though the sovereign whom he should depose were, in every respect, not merely blameless but meritorious. It was reason enough for the change that the pope deemed it convenient. The spouse of the church was vice-God: men were commanded to bow at his name, as at the name of Christ; the proudest sovereigns waited upon him like menials, led his horse by the bridle, and held his stirrup while he alighted; and there were ambassadors who prostrated themselves before him, saying, 'O thou that takest away the sins of the world, have mercy upon us!' The advocates of the papal power proclaimed that any secular laws which might be passed, against a decree of the Roman Pontiff, were in themselves null and void: and that all pontifical decrees ought for ever to be observed, by all men, like the word of God; to be received as if they came from the mouth of St. Peter himself, and held like canonical scripture. Neither the Catholic faith, nor the four evangelists, could avail those who rejected them, this being a sin which was never to be remitted. Christ had bestowed upon the pope, when he spake as such, the same infallibility which resided in himself. And were he utterly to neglect his duty, and by his misconduct draw down innumerable souls to hell with him, there to be eternally tormented, no mortal man might presume to reprove him for his faults.

Even this monstrous proposition was advanced, that, although the Catholic faith teaches all virtue to be good and all vice evil, nevertheless if the pope, through error, should enjoin vices to be committed, and prohibit virtues, the church would be bound to believe that vices were good and virtues evil, and would sin in conscience were it to believe otherwise. He could change the nature of things, and make injustice justice. Nor was it possible that he should be amenable to any secular power; for he had been called God by Constantine, and God was not to be judged by man: under God, the salvation of all the faithful depended on him, and commentators even gave him the blasphemous appellation of 'our Lord God the pope!' It was disputed in the schools whether he could not abrogate what the apostles had enjoined; determine an opinion contrary to theirs, and add a new article to the creed; whether he did not, as God, participate both natures with Christ: and whether he were

not more merciful than Christ, inasmuch as he delivered souls from the pains of purgatory, whereas we do not read that this was ever done by our Saviour. Lastly, it was affirmed that he might do things unlawful, and thus could do more than God. All this was certain, because the church was infallible. Where this fallibility resided the Romanists have differed among themselves, some vesting it in the pope, others requiring the concurrence of a general council. Infallible, however, it was determined that the Roman Catholic church must be, and thus the keystone was put to this prodigious structure of imposture and wickedness. No one acquainted with ecclesiastical history will consider this view of the morals and conditions of the Roman church as exaggerated or incorrect. We will therefore turn to a more grateful subject, and briefly trace the various efforts which were made to correct this lamentable state of things, and to bring back the church to its original purity and discipline.

II. *The early efforts at reform.*—As early as the reign of Charlemagne, Paulinus, a royal favorite, and the bishop of Aquila, employed his voice and his pen to arrest the progress of these and similar corruptions. In the year 804 his honorable career was terminated, and in a few years later it devolved on the celebrated Claude of Turin to check the same abuses, to advocate the same truth, and to scatter more widely the seeds of future opposition and reform. The sovereignty of the Redeemer in his church was so maintained by this prelate as virtually to annihilate the ambitious pretensions of the Roman see. The worship of images he denounced as gross idolatry; the childish veneration of relics he exposed to its deserved contempt: and, discarding prayer for the dead as the device of man, his zeal bowed to no authority in religion, opposed to the obvious meaning of the sacred Scriptures. Explaining the doctrine of justification by faith alone, with a force and perspicuity not unworthy of Luther, the papal scheme of merit was greatly broken and impeded by his labors. More than twenty years of his life were devoted to this warfare against the prevailing superstitions, and to the cause of Christian truth, as embraced by its earliest disciples.

The episcopal authority of Turin extended over the valleys of Piedmont, and that the faith defended by Claude was preserved on that locality through the ninth and tenth centuries is the testimony of Catholic writers. Before the close of this period the fires of persecution were kindled in that favored diocese, in the hope of consigning both the name and the doctrine of its distinguished reformer to oblivion. But in the hour of trial the disciple was often found to be worthy of his master; while the zeal of such as were expelled their home increased by a natural process with the increase of suffering, never failing to convert the fact of their dispersion into the means of imparting a more extended influence to their obnoxious creed. It was in the century commencing with the year following that in which the poem of the Troubadours, entitled *La Nobla Leyczon*, was completed, that Peter de Brugs, became distinguished in Provence and



Languedoc, as the intrepid advocate of certain reformed opinions; and his zeal, after the labor of twenty years, sustained the trial of martyrdom. On his decease his place was more than supplied by the learning and the invincible ardor of Henry the founder of the sect called Henricians. But, if Henry imbibed the zeal of his predecessor, he had also to share in his reward. The invective in which these preachers indulged on the manners of their age, and especially on the vices of the clergy, was not to be patiently endured. It roused the displeasure of the pontiffs and of their court; and, in the name of Eugenius III., the person of Henry was seized and committed to prison, where, after a brief interval, his life was the sacrifice incurred by his unshaken integrity. Such are the measures which have been long and widely adopted to crush the leaders of reform, and experience has shown how little they are suited to diminish either the number or the ardor of its advocates. But if the Petrobrussians and Henricians were sufficiently numerous to excite the alarm of the church, it is certain they were but few and feeble when compared with their opponents.

It was towards the close of the century, in the former half of which they had flourished, that the ear of Europe became familiar with the name of Arnold of Brescia, as that of a more daring opponent of clerical ambition. This extraordinary man had suddenly risen from the lowest rank in the church, and there are facts included in his history which impart to it an unusual interest. He studied under the famous Abelard, and had probably adopted some of the speculations which exposed the lover of Eloise to the frown of the church. But with the skill of the master the disciple associated an independence and hardihood peculiar to himself. In the garb of a monk, and with a countenance which bespoke his decision and capacity, but which had already become marked with many cares, Arnold commenced his stormy career, as a preacher in the streets of Brescia. Arraigned before the prefect of the city, the reformer was condemned to die; and, deserted (perhaps of necessity) by his more powerful adherents, he perished at the stake, amid the idle gazings of the Roman populace. His ashes were given to the Tiber; but his opinions were not so easily consigned to oblivion. But ten years from that period had scarcely passed, when Peter Waldo, an opulent merchant of Lyons, became known in that city as an opponent of the Romish superstition, and a zealous advocate of what has since been designated the reformed faith. Waldo had witnessed the sudden decease of a friend at his table, and a disposition already favorable to religion was much confirmed by the affecting incident. Often scandalised by the manners of the clergy, his superior education had enabled him to consult the Latin Version of the Scriptures. From that source he derived the instruction which taught him to separate from communion with the papal church. His morals had ever defied the breath of calumny; from this period his wealth ministered largely to the comforts of the poor; and if his opposition to vice and error exposed him to the malice of interested men, his fearless

enforcement of the truths of the Gospel won the applause and the grateful attachment of multitudes. For a season he found his protection in his rank, in the influence of his connexions, and in the number of his followers. But the inroads of his zeal which had thus eluded every hostile purpose of the local authorities were, at length, deemed so serious an innovation as to require the most formal interference of the papacy. In a council convened by Alexander III. Peter Waldo and his numerous disciples were presumed to be convicted of heresy, and until signs should be given of repentance they were cut off from all communion with the faithful. This sentence would probably have been little regarded, had it not, through the ferocity of the times, become no less destructive of civil than of religious communion. The Lyonese, who were not fully prepared to brave the wrath of the church, were constrained to refuse the hated sectaries even the remotest intercourse of social life. That flourishing city was, in consequence, deserted by a large, and by the most valuable, portion of its inhabitants; but like the Hebrew tribes they were not to be lost in their dispersion. Waldo continued to publish his doctrine with great success, through Dauphiny, Picardy, and various of the German states, concluding a labor of twenty years in a province of Bohemia. His disciples, every where harassed by the hand of persecution, are still found associated with almost every continental sect, and by a benevolent arrangement of providence they were preserved as witnesses for the truth until the age of Luther. Aware of the assistance which he had derived from the Scriptures, and of the principles which assert them to be the property of the people no less than of the priest, it had been an object of early solicitude with Waldo to confer upon his followers a vernacular translation of the inspired volume. It was a novelty in modern Europe, and contributed much to his unprecedented success in the work of reformation. The *Noble Lesson*\* had long since supplied the devout with a valuable summary of Scripture history, and of the doctrines and the duties of the Gospel; but such was the impulse given to the mind of multitudes by the possession of the Scriptures, that the numerous sectaries, however poor and despised, were generally capable of vindicating their peculiarities of custom or opinion by an appeal to that authority; it was even their boast that there was scarcely a man or woman among them who was not far better read in the Bible than the doctors of the church. Waldo finished his career in 1179, and it was two years later that the pontiff, Lucian III., issued his memorable decree, condemning all manner of heresy, by whatever name denominated. By the haughty Innocent III. every motive which superstition could supply was employed to arm the princes and the people of Europe against the pacific disciples of the Gospel. To extirpate

\* *La Noble Leyczon*, or *The Noble Lesson*, is a poem in the language of the Troubadours; the depository of opinions, and an expression of feelings, not unworthy of the professors of the Gospel in the most favored period of its history.

them by fire and by the sword was the object distinctly proposed; and the indulgences so impiously connected with the crusades into Asia were now as freely bestowed on such as became devoted to this murderous cause. Under the impulse of such motives towns were taken in succession, and their inhabitants slaughtered with an atrocity which spared neither age nor sex.

A volume might be occupied in detailing these atrocities, but it must be sufficient to observe, in the language of Mr. Gibbon, 'that pope Innocent III. surpassed the sanguinary fame of Theodore. It was in cruelty alone her soldiers could equal the heroes of the crusades, and the cruelties of her priests were far excelled by the founders of the inquisition, an office more adapted to confirm than to confute the belief of an evil principle.' The interval between the former half of the thirteenth century, with which these crusades were connected, and the middle of the following, in which Wycliffe appeared, is one of unusual gloom in the history of true religion. The efforts of the Waldenses and Albigens to restore its purity, and which has not been improperly designated the first reformation, appeared as a total failure, and through nearly 300 succeeding years the good which it was designed to confer on the nations of the western empire was effectually resisted. And not only so, the machinery of despotism appeared to become every day more matured, and every struggle of its victims but to place them more completely beneath it.

III. *Rise and progress of Wickliffe's doctrines in England.*—The manifold and complicated evils of popery, however, reached their highest pitch about the thirteenth or fourteenth century. That astonishing system of spiritual tyranny, for instance, had now drawn within its vortex almost the whole government of England. The pope's haughty legate, spurning at all law and equity, made even the ministers of justice to tremble at its tribunal; parliaments were overawed, and sovereigns obliged to temporise, while the lawless ecclesiastics, entrenched behind the authority of councils and decrees, set at nought the civil power, and opened an asylum to any, even the most profligate, disturbers of society. In the mean time the taxes collected, under various pretences, by the agents of the see of Rome, amounted to five times as much as the taxes paid to the king. The insatiable avarice and insupportable tyranny of the court of Rome had given such universal disgust, that a bold attack, made about this time, on the authority of that court, and the doctrine of the church, was, at first, more successful than could have been expected in that dark and superstitious age. This attack was made by the famous John Wickliffe, who was one of the best and most learned men of the age in which he flourished. His reputation for learning, piety, and virtue, was so great, that archbishop Islip appointed him the first warden of Canterbury College, Oxford, in 1365. The lectures in divinity which he read in that university were much admired, though in these lectures he treated the clergy, and particularly the mendicant friars, with no little freedom and severity. A discourse which he published against

the pope's demand of homage and tribute from Edward III., for the kingdom of England, recommended him so much to that prince that he bestowed upon him several benefices, and employed him in several embassies. Edward III. had refused that homage to which King John had subjected his successors, and Urban V. threatened that if it were not performed he would cite him to Rome, there to answer for the default. A sovereign of Edward's ability and renown was not thus to be intimidated; the feeling of the country was with him, and the parliament, affirming that what John had done in this matter was a violation of his coronation oath, declared that, if the pope proceeded in any way against the king, he and all his subjects should with all their power resist him. The papal claims were defended by a monk, who ventured to challenge Wickliffe upon the subject, who coming forward with superior ability, and in a better cause, produced a conclusive reply; in reward for which, when an appeal concerning the wardenship was decided against him, he was appointed professor of divinity, and, as a further mark of favor, the living of Lutterworth in Leicestershire was given him. Two years after his appointment to the divinity chair he was named, with other ambassadors, to meet the pope's representative at Bruges, and resist his pretensions to the presentation of benefices in England, an injurious practice, against which several statutes had been passed. The negotiation lasted nearly two years, and it is probable that what he then had opportunities of discovering convinced him that the system of the papal court and its doctrines were equally corrupt. For on his return he attacked it in the boldest manner, maintained that the Scriptures contained all truths necessary to salvation, and that the perfect rule of Christian practice was to be found in them only; denied the authority of the pope in temporal matters; proclaimed that he was that man of sin, the son of perdition, whom St. Paul prophetically denounces, 'sitting as God in the temple of God, showing himself that he is God;' and denounced him as anti-christ. These opinions he openly preached and published, appealing to the Scriptures for their truth; and they were propagated by his disciples, who attacked the friars in their own manner, preaching to the people, and going about, as he himself did, barefoot, and in plain fringe gowns. It was not long before he was accused of heresy, and orders came to Sudbury the primate, and Courtney the bishop of London, to have him arrested, and kept in close custody till they should receive further instructions. But the duke of Lancaster, John of Gaunt, who was then governing the kingdom during the latter days of his father, protected him with a high hand; and he was still so popular in Oxford that, when a nuncio was sent thither, requiring the university, under pain of the severest penalties, to deliver him up for justice, the threat was disregarded. The archbishop, finding it impossible to proceed in the summary manner which the pope ordered, summoned him to appear within thirty days before him and the bishop of London, at a synod held in St. Paul's; and Wickliffe, confident in his cause and in his protectors, hesitated not to

obey. It is not, however, likely that any protection could long have upheld him against the ecclesiastical authority, if a schism had not at this juncture occurred to weaken the papal power, and shake its very foundations. Wickliffe seized the advantage which was thus afforded him, and set forth a tract upon the schism, exposing the absurdity of ascribing infallibility to a divided church. While the doctrines of Wickliffe were propagated and opposed with much zeal at Oxford, and at other places, he being in a declining state of health resided, during the two last years of his life, at his living of Lutterworth, in Leicestershire, employed in finishing his translation of the Bible and other works. Being seized with a stroke of the palsy, which deprived him of his speech December 28th, 1384, he expired on the last day of that year.

The invention of printing had, at this time, created facilities for the diffusion of knowledge, unknown before; and the struggle between the elements of darkness and the principles of light resembled, for a while, the smothering vapor which precedes the burst and the radiance of a clear and steady flame. Thousands were prepared by these antecedent causes to receive the truth in all its holy purity, and sacred influence. Already the rays of truth were emanating from the sacred volume in all directions; and men were beginning to start as from the slumbers of a dream, or the reveries of a distempered imagination. It must not, however, be supposed that this change of opinion escaped the notice of the dominant church; or that it was negligent of that strong arm of power which it possessed, in order to suppress the growing heresy. Henry IV., at the instigation of the clergy, passed a statute, forbidding the propagation of the new doctrine by preaching, writing, teaching, or discourse; and demanding of all persons the renunciation of their errors, on pain of being condemned for heresy, and burnt alive.

William Sautre, the parish priest of St. Osithes, in London, and formerly of St. Margaret's, at Lynn, in Norfolk, was the first victim under this new statute, and the first martyr for the reformation in England. The single question with which he was pressed was, whether the sacrament of the altar, after the pronouncing of the sacramental words, remained material bread or not. It was not sufficient for him to declare a firm belief that it was 'the bread of life which came down from heaven;' he was required to acknowledge that it ceased to be bread. Finding it in vain to protest that he attempted not to explain what is inexplicable, his final answer was that the bread, after consecration, remained very bread as it was before. He was then pronounced to be judicially and lawfully convicted as a heretic, and as a heretic to be punished; and being, moreover, a relapsed heretic, to be degraded, deposed, and delivered over to the secular arm.

This being the first condemnation of the kind in England, Arundel was punctual in all its forms, that they might serve for an exact precedent in future. They were, probably, derived from the practice of the accursed inquisitors in Languedoc; and they were well devised for pro-

longing an impression of horror upon the expectant and awed spectators. Sautre was brought before the primate and six other bishops, in the cathedral of St. Paul's; they were in their pontifical attire, and he appeared in priestly vestments with the paten and chalice in his hands. Arundel stood up, and, in the name of the Father, and of the Son, and of the Holy Spirit (thus profaned in this inhuman progress), degraded him, first from his priestly order, and, in sign of that degradation, took from him the paten and chalice, and plucked the priestly casule from his back. The New Testament was then put into his hands, and taken from him; the stole being at the same time pulled off, to degrade him from the office of deacon. By depriving him of the alb and maniple, his deprivation from the order of subdeacon was effected. The candlestick, taper, and urceole, were taken from him as an acolyte; and the book of exorcisms, as exorcist; the lectionary, as reader; he then remained in a surplice as sexton, and, with the key of the church door: these also were taken from him; the priest's cap was then to be laid aside, the tonsure rased away, so that no outward mark whatever of his orders might remain; the cap of a layman was placed upon his head, and Arundel then delivered him, as a secular person, to the secular court of the high constable and marshal of England, there present, beseeching the court to receive favorably the said William Sautre, unto them thus committed! For with this hypocritical recommendation to mercy the Romish church always delivered over its victims to be burnt alive. Sautre accordingly suffered martyrdom at the stake; leaving a name which is still slandered by the Romanists, but which the church of England will ever hold in deserved respect.

At this time twelve inquisitors of heresy, for this dreadful name had been introduced in England, were appointed at Oxford, to search out heretics and heretical books. They presented as heresies 246 conclusions, deduced, some truly and some falsely, from the writings of Wickliffe's followers, and of the Lollards; and they represented that Christ's vesture without seam could not be made whole again, unless certain great men, who supported the disciples of Wickliffe, were removed; particularising Sir John Oldcastle, who, in right of his wife, was lord Cobham, a man of high birth, and at that time in favor with Henry V. Him they accused to the king of holding heretical opinions concerning the sacrament, penance, pilgrimages, the adoration of images, and the authority of the Romish church, declaring their intention of proceeding against him as a most pernicious heretic.

In better reliance upon a good cause than upon popular favor and his own means of resistance, he wrote a paper, which he entitled the Christian belief of the lord Cobham; and with this he went to the king, trusting, it is said, to find mercy and favor at his hand. The writing began with the Apostle's creed, to which a larger declaration of his faith was added. Like Wickliffe, he expressed an opinion that the church was divided into three parts, the saints in heaven, the souls in purgatory, and the faithful on earth;

but he qualified this admission of a purgatory, by saying if any such place be in the Scriptures: the duty of the priests was that, secluded from all worldliness, they should conform their lives to the examples of Christ and his apostles, evermore occupied in preaching and teaching the Scriptures purely, and in giving wholesome examples of good living to the other degrees; more modest also, more loving, gentle, and lowly in spirit should they be than any other people. The duty of the people was, 'to bear their good minds and true obedience to the foresaid ministers of God, their king, civil governors, and priests; justly to occupy every man his faculty, be it merchandise, handicraft, or the tilth of the ground, and so one to be helper to another. He then professed his full belief that the body and blood of Christ were verily and indeed contained in the sacrament of the altar under the similitudes of bread and wine; that the law of God was most true and perfect, and that they which did not so follow it in their faith and works (at one time or other) could not be saved; 'whereas he that seeketh it in faith, accepteth it, learneth it, delighteth therein, and performeth it in love, shall taste for it the felicity of everlasting innocency. Finally, that God will ask no more of a Christian believer, in this life, than to obey the precepts of this most blessed law. If any prelate require more, or any other kind of obedience than this, he contemneth Christ, exalteth himself above God, and so becometh an open antichrist.' He required that the king would cause this his confession of faith to be justly examined by the wisest and most learned men in the realm; and that, if it were found in all parts agreeing to the truth, it might be so allowed, and he himself thereupon holden for none other than a true Christian; or that it might be utterly condemned if it were found otherwise, provided always that he were taught a better belief by the word of God, which word he would, at all times, most reverently obey.

When the king allowed him in his presence to be personally cited, lord Cobham perceived that his destruction was determined on, and, rejecting the archbishop as his judge, appealed from him to the pope; this appeal being disallowed he was immediately committed to the tower, till the day appointed for his examination. On that day at the Dominican convent within Ludgate, many canonists and friars, the heads and leading persons of their respective orders, were convened to sit in judgment on him; while a number of priests, monks, canons, and friars, with a rabble of underlings, who were collected as spectators, insulted him as he came, for a horrible heretic, and a man accused before God. These preparations, and the certainty of what was to ensue, could not shake the constancy of his resolved mind. But the taunts and mockery of the brutal audience who came there as to a spectacle, and anticipated with exultation the inhuman catastrophe, disturbed that equanimity which he had hitherto preserved; and moved him, not to an unseemly anger, nor to aught unworthy of himself, but to an emotion than which nothing nobler in its kind hath been imagined in fiction, or recorded in history. For when Arundel began the

tragedy, by offering him absolution and mercy, if he would humbly desire it, in due form and manner, as the church ordained.—'Nay, forsooth, will I not,' he replied, 'for I never trespassed against you, and therefore I will not do it!' Then kneeling on the pavement, and holding up his hands toward heaven, he exclaimed, 'I shrive me here unto Thee, my eternal, living God, that in my youth I offended thee, O Lord, most grievously in pride, wrath, and gluttony; in covetousness, and in lechery! Many men have I hurt in mine anger, and done many other horrible sins! Good Lord, I ask Thee mercy!' He wept while he uttered this passionate prayer; then, standing up, said with a mighty voice, 'Lo, good people, lo! for the breaking of God's law and his commandments, they never yet cursed me! but for thine own laws and traditions most cruelly do they handle both me and other men. And, therefore, both they and their laws, by the promise of God, shall utterly be destroyed!'

When they had recovered from the surprise which this awful appeal produced, they began to examine him concerning his belief. He replied with the same intrepid spirit, 'I believe fully and faithfully in the universal laws of God. I believe that all is true which is contained in the Holy Scriptures of the Bible. Finally, I believe all that my Lord God would I should believe.' They pressed him with the murderous question concerning material bread. He made answer, 'The Scriptures make no mention of this word material, and therefore my faith hath nothing to do therewith. But this I say, and believe, that it is Christ's body and bread.' They exclaimed against this with one voice; and one of the bishops stood up and said, 'It was a heresy manifest, to say that it is bread after the sacramental words were spoken.' The noble martyr replied, 'St. Paul was, I am sure, as wise as you, and more godly learned, and he called it bread, 'the bread that we break,' saith he, 'is it not the partaking of the body of Christ?' And as for that virtuous man, Wickliffe, I shall say here, both before God and man, that before I knew that despised doctrine of his I never abstained from sin. But, since I learned therein to fear my Lord God, it hath otherwise, I trust, been with me, so much grace could I never find in all your glorious instructions! One pope hath put down another, one hath poisoned another, one hath cursed another, and one hath slain another, and done much more mischief, as all the chronicles tell. Let all men consider well this, that Christ was meek and merciful; the pope is proud and a tyrant—Christ was poor and forgave; the pope is rich, and a malicious manslayer, as his daily acts do prove him. Rome is the very nest of antichrist, and out of that nest cometh all the disciples of him, of whom prelates, priests, and monks are the body, and these piled friars are the tail! Though he judge my body, which is but a wretched thing, yet am I certain and sure that he can do no harm to my soul, no more than could Satan upon the soul of Job. He who created that, will, of his infinite will and promise, save it; I have therein no manner of doubt. And, as concerning these articles before rehearsed, I will stand to them, even to the very death, by the

grace of my eternal God !' Turning to the spectators then, he spread his hands, and spake with a louder voice, 'Good Christian people, for God's love be well ware of these men! for they will else beguile you, and lead you blinding into hell with themselves. For Christ saith plainly unto you, If one blind man leade another, they are like both to fall into the ditch!' Then, kneeling down before them, he prayed for his enemies: 'Lord God eternal! I beseech thee, of thy great mercy's sake to forgive my pursuers, if it be thy blessed will!' Being committed to the Tower, whence he escaped, a large reward was offered for taking lord Cobham, alive or dead; so faithfully, however, was he sheltered, notwithstanding all who harboured him incurred the same danger with himself, that he eluded his persecutors for four years, until he was discovered, by means of lord Powis, in Wales. He now stood resolutely upon his defence, and would probably not have been taken alive, if a woman had not broken his legs with a stool. In this condition he was carried to London in a horse litter; and there, being hung by the middle in chains, was consumed in the flames praising God.

IV. *The Bohemian reformers.*—The historians of the Reformation too generally represent that great revolution to originate exclusively with Luther and his friends; in Germany, however, as well as in England, the pure sentiments, the holy lives, and the triumphant deaths of the martyrs, from the twelfth to the fifteenth centuries, paved the way for their successors of the sixteenth. Before we enter on the history of the rupture between the German princes and the papacy, we shall briefly notice that of the Bohemian reformers. Bohemia partook of the general corruption, and was immersed in darkness and superstition, when Waldo and his friends sought an asylum in that kingdom, and in the year 1176 formed a colony at Saltz and Laun, on the river Eger. These Waldenses found the Bohemians scarcely less superstitious than the members of the church of Rome; but subsequently introduced among them the knowledge of the Christian faith in its purity, according to the word of God. On the introduction, however, of popery, through the influence of Charles IV., ignorance, profligacy, and corruption of manners, began to prevail among all orders of the people; the inquisition was introduced for the purpose of enforcing despotism in the civil government, and uniformity of opinion in matters of religion. The consequence was, that multitudes withdrew themselves from the public places of worship, and followed the dictates of their own consciences, by worshipping God in private houses, woods, and caves. Here they were persecuted, dragooned, drowned and killed; and thus matters went on until the appearance of John Huss and Jerome of Prague. John Huss, who had been a student in the university of Prague, where he had taken his degrees, and become a zealous disciple of Wickliff, was born in the village of Hussinetz, in 1373, of parents not in affluent circumstances. He was a person of eminent abilities, and of still more eminent zeal; his talents were popular, his life irreproachable, and his manners the most affable and engaging. He was the idol of the

populace; but, in proportion as he attracted their esteem and regard, he drew upon himself the execration of the priests. The introduction of Wickliff's writings into the university of Prague gave great offence to the archbishop of Prague, who issued a decree that every person who was in possession of them should bring the books to him, in order that such as contained any thing heretical might be burnt. Huss, and the members of the university, entered a protest against these proceedings, and on the 25th of June, 1410, appealed from the sentence of the archbishop to the court of Rome. The affair was carried before pope John XXIII., who granted a commission to cardinal Colonna to cite Huss to appear personally before him at Rome, there to answer the accusations laid against him of preaching both errors and heresies. Huss desired to be excused a personal appearance, and so greatly was he favored in Bohemia, that king Wenceslaus, his queen, the nobility, and the university at large, joined in a request to the pope that he would dispense with such an appearance; and, moreover, that he would not suffer the kingdom of Bohemia to be subject to the imputation of heresy, but permit them to preach the gospel with freedom in their places of worship, and that he would send legates to Prague to correct any presumed abuses, the expense of which should be defrayed by the Bohemians. Three proctors were despatched to Rome to tender Huss's apology to his holiness; but the excuses alleged were deemed insufficient, and Huss, being declared contumacious, was accordingly excommunicated. This excommunication extended also to his disciples and friends; he himself was declared a promoter of heresy, and an interdict was pronounced against him. Urban VI., who had succeeded to the pontificate on the death of Gregory XI., A. D. 1378, having rendered himself odious in the eyes of his subjects, the cardinals so resented his conduct that they set aside his election, and chose Clement VII. in his room. The adherents of both pontiffs were indefatigable in their exertions to support their respective pretensions, and much human blood was spilt in the contest. To terminate this disgraceful schism, a third pope, Alexander V., was elected, in the hope of inducing the resignation of the others. Neither of them, however, would give up his power; and the world now saw three popes ruling at one and the same time. With a view to heal the fatal schisms, and repair the disorders that had sprung up during their continuance, as well as to bring about a reformation of the clergy, which was now loudly and generally called for, in the year 1414 the emperor Sigismund convened the council of Constance.

Hither, from all parts, princes and prelates, clergy and laity, regulars and seculars, flocked together (November 16th, 1414), to determine the dispute between the three contending factions for the papacy; and thither Huss was cited to appear, in order to justify his conduct and writings. The emperor Sigismund, brother of Wenceslaus, encouraged Huss to obey the summons, and, as an inducement to his compliance sent him a passport with assurance of safe conduct, permitting him to come freely to the council, and pledging himself for his safe return

Huss consented; but no sooner had he arrived within the pope's jurisdiction, than, regardless of the emperor's passport, he was arrested and committed close prisoner to a chamber in the palace. This violation of common law and justice was noticed by the friends of Huss, who had, out of the respect they bore his character, accompanied him to Constance. They urged the imperial safe conduct; but the pope replied that he never granted any safe conduct, nor was he bound by that of the emperor.

Jerome of Prague was the intimate friend and companion of Huss; inferior to him in age, experience, and authority, but his superior in all liberal endowments. He was born at Prague, and educated in that university. Having finished his studies he travelled into many countries of Europe. The universities of Prague, of Paris, of Cologne, and of Heidelberg, conferred upon him the degree of M. A.; and, having made the tour of the continent, he visited England, where he obtained access to the writings of Wickliffe, which he copied out, and returned with them to Prague. As Jerome had distinguished himself by an active co-operation with Huss in all his opposition to the abominations of the times, he was cited before the council of Constance on the 17th April 1415, at the time his friend Huss was confined in a castle near that city. Arriving shortly afterwards in Constance, or the neighbourhood, he learned how his friend had been treated, and what he himself had to expect; on which he prudently returned to Ibergingen, an imperial city, whence he wrote to the emperor and council, requesting a safe conduct; but, not obtaining one to his satisfaction, he was preparing to return into Bohemia, when he was arrested at Kirschaw, and conveyed to Constance. Every one knows the fate of these two eminent men. They were both condemned by the council to be burnt alive, and the sentence was carried into effect. Huss was executed on the 7th July 1415; and Jerome on the 20th of May 1416.

*V. The reformation in Germany.*—If, in the following sketch of the circumstances which preceded and produced the Reformation we seem to look principally to the efforts of the German reformer, it must be remembered that the great work, then generally designated, was begun in Germany, and that, although political and personal circumstances apparently produced the rupture between England and Rome, the minds of men had been previously prepared for a thankful embrace of it, by the writings of Luther; that the political causes were only accidental ones, providentially concurring with those of a moral nature; and that, so far from being considered as independent and isolated events, the Reformation both in England and Germany was one and the same event under different appearances and modifications.

With this caution we now proceed to state what to us appear to have been the more proximate causes of the Reformation, first begun in the early part of the sixteenth century.

In the first instance it was not against the Catholic dogmata, but against the abuses and the corruption of the papal court, as 'in the case of

indulgences,' that Luther and others directed their zeal. Our intrepid reformer does not appear at all to have originally contemplated an attack against transubstantiation, purgatory, praying for the dead, the use of images and pictures, the veneration of relics, tradition as a rule of faith, the invocation of saints, or even against the use and sale of indulgences. It was not against all or any of these Catholic tenets that the reformers, in the first instance, protested. The extreme laxity and even profligacy of the clergy had long been the source of painful regret to the wise and good, and of sarcasm, impious pleasure, and contempt, to the wicked and the vain. Cardinal Bellarmine, a writer, as all the world knows, but seldom disposed to say a syllable in disparagement of the church or the Roman court, confesses that, 'for some years before the Lutheran and Calvinistic heresies,' as he expresses it, 'were published, there was not, as contemporary authors testify, any severity in ecclesiastical judicatories, any knowledge of sacred literature, any reverence for divine things; there was not almost any religion remaining.' Had the moral conduct of the head, and ministers of religion, been such as became their holy office, it is more than probable that no particular outcry would have been raised against the Catholic doctrines at that time. No, it was the base conduct of the clergy that first sounded the tocsin of religious war. This depravity had, naturally enough, become the subject of public ridicule, of reproach, and at last of contempt and open opposition. The universal cry was 'Reform!' and when this cry was rejected another still more powerful and dreadful was raised of 'Destruction!'

The holiness of the church became the first object of general attack; and, unfortunately for herself, that which should have been her strongest hold was the most vulnerable part in the whole fortress. The outcry was not against the host, but against him by whom it was elevated. Holy images, pictures, relics, and shrines, were never despised till they were abused and profaned by those to whose custody they had been previously consigned. The growing pride of the church of Rome, naturally engendered by the union of the spiritual and temporal power, was one of the strong symptoms of approaching revolt. Every prince bore the insolence and ambition of the Roman pontiff with a greater or less degree of impatience. Some of them dared to oppose it openly, and the university of Paris had more than once been made the organ of sovereign power to answer the menaces of Rome, they had the courage to appeal to a future council, which they, without ambiguity, deemed superior to the pope. The eyes of men began to open. The impolitic violence of some popes; the scandalous lives of others; the seventy years captivity at Avignon; the schism of forty other years which followed it, in which two and sometimes three popes appeared, each having a party, abusing and excommunicating each other, loading each other with the most revolting insults, and reproaching each other with the lowest vices—unexpected discoveries which covered both rivals with ignominy at the same time; all these will

surely account for the hatred and contempt which every where lurked secretly against the Romish hierarchy. Complaints and murmurs arose on every hand; thousands of voices united in demanding a reformation of the church in its head and in its members, in its faith and in its manners. Next to the lordly pride of the Roman court we may reckon among the proximate causes of the Reformation the luxury, extravagance, and religious indifference of Leo X.

About the period of Luther's first attack on the religion of the Catholics, Rome was in profound peace; and this interval of repose Leo X. occupied in expensive schemes for aggrandizing the family of the Medici; in expending the splendor of the papal see; and in lavishing presents on authors, artists, profane wits, and buffoons. To support the enormous expenses to which these propensities subjected the supreme pontiff required far greater resources than the now almost exhausted papal treasury supplied. Yet at no time was the Roman court in greater splendor, nor did the vicars of Christ ever exhibit a magnificence so imposing as that displayed during the pontificate of Leo X. Every decoration that art could suggest; every wish that the most voluptuous appetite could engender; and every refinement that an unbounded love of science and literature could devise; found a patron in that luxurious prince. This profusion and magnificence in the supreme pontiff was amply copied by the chiefs and the princes of the Roman court, who vied with each other in the grandeur and sumptuousness of their palaces, and the prodigality and gaiety of their entertainments; nor did it deduct from the pressure to which this extravagance exposed the subjects of the papal dominion, that a considerable portion of the riches which were drained from the labor or the purses of the poor was lavished without discrimination on artists, painters, and sculptors. Divine providence, intending on the one hand to chastise the church for her profligacy of manners, and on the other to free the gospel of Christ from the errors and corruptions which had grown upon it, seems to have lulled the supreme pontiff to a fatal security, and to have struck with blindness those whom it designed to punish.

An admirer of the fine arts, from which he only sought fame and gratification, a crafty but presuming politician, prepossessed with contempt for the German rudeness of manners, under which he was unable to discover that strength and manliness of character, all the energy of which he had to encounter, Leo X. was not qualified to enter the lists with Luther; and the arrogant weakness of the one opened numberless advantages to the intrepid firmness of the other. Whoever considers the characteristic national differences between the Italians and Saxons will perceive that divine providence had been secretly but effectually preparing for that great Reformation in the church. The Italians adhered strongly to a religion which captivated their senses, and permitted indulgence of their vices. A taste for luxury, pomp, and voluptuousness, with that of the fine arts, was all their enjoyment; always oppressed, they were naturally deceitful, cunning, dissimulating; and self-

ish; every thing conducive to the enjoyment of taste, every thing flattering to the sensibility, physical and moral, had become the object of Italian activity. But the calm, equal, persevering activity of the Saxons was directed to the abstract sciences, to philosophy, to historical researches. When the Reformation burst forth, there was not a single theologian of Italy capable of encountering those of Saxony; some of them had the presumption to attempt it,—a presumption always the associate of ignorance; they were defeated and covered with confusion; in revenge Italy boasted loudly of her poets and her painters; they had not produced a Luther, but Saxony had not produced an Ariosto.

The recent invention of the art of printing operated in a very powerful manner to bring into circulation those principles which, at length, produced the Reformation. The revival of literature about this period under the especial patronage of Leo gave a stimulus to every effort of intellect. Hence the reproaches so profusely cast on the conduct of the clergy were carried by means of the press to every cottage, and were read with eagerness by both the pious and the profane; by those who saw the decay of devotion in the people, and the licentiousness of the clergy, with sentiments of sorrow, and a wish to have them reformed; and also by those who saw these evils with a malicious pleasure, and a secret desire for the ruin of the Roman court, and the destruction of the papal hierarchy.

The ill use which Tetzel and others made of the sale of indulgences is a cause of the Reformation which has been repeated by every writer on the subject since the days of Luther. The splendor and magnificence of the papal see have been already stated; but we deferred to notice the enormous expenses to which the Roman government was subjected, in the completion of the astonishing fabric begun during the pontificate of Julius II., the church of St. Peter at Rome. To accomplish this stupendous undertaking large supplies were become indispensably needful; and Leo X., as almost a last resource, resorted to a measure which had been applied to as early as A. D. 1100, when Urban II. granted a plenary indulgence and remission of sins to all such persons as should join in the crusades to liberate the holy sepulchre from the hands of the infidels. In thus reviving an ancient practice Leo X. was not introducing any new mode of taxation; yet he took no pains to secure the church from the disgrace which she subsequently sustained by the improper use of this extraordinary species of traffic. But the mere act of vending remittances of holy discipline was not all. The commissioners in this noble traffic were not chosen from among the ranks of wise, prudent, and honest men. John Tetzel, a Dominican friar, of the most depraved habits and vicious principles, was appointed by Albert, archbishop of Mentz, to dispose of these dishonorable wares to the credulous and deluded people. Being determined to extend the benefit of his commerce as much as possible, he scrupled not to exceed the bounds of his commission, nor to extol his merchandise as abounding with every virtue that the most meritorious

sacrifice or service could confer. To such an impious length did this agent of iniquity extend his blasphemies as to declare that these indulgences would atone for every vice,—past, present, or to come,—and remit every punishment, both in this life and in the next, to which the most profligate wretch could be exposed!

This blasphemous and most ridiculous fraud was played off upon the people in every possible shape, while the infamous fabricator and vender wallowed in every species of luxury, debauchery and wickedness; an abuse so flagrant could not but cause the honest indignation of every thinking person. Accordingly, when a knowledge of these practices came to the ear of Martin Luther, all the greatness of his soul was called into action, and he inveighed not, at first, against indulgences themselves, but against that torrent of corruption which Tetzel's abuse of them was bringing into Christendom. But it is not to be supposed that an institution of so long standing, ingrafted on so many prejudices and interests, and supported by such an extraordinary weight of power and influence, could be overturned by any of the aforementioned causes, unless those causes had been called into action by some bold and intrepid spirit; some daring soul, impatient of the crown of martyrdom, and indifferent to every consideration that contributed not to advance the glory of his character, the immortality of his memory, and, above all, the interests of that religion to which he was devoted. Inspired by a zeal which could consume the most obdurate prejudice, and a courage that could brave the most potent authority, Luther carried every thing before him that retarded his designs. He knew when to advance, and when to make good a safe retreat; when to trust the energies of his own mind, and when to profit by the advice of others.

The Europeans, who till this time had been confined within the limits of the old world, had just launched beyond it; the road to India and America had been lately discovered. While enterprising navigators were in this manner subduing an ocean that had been unconquerable, every mind seemed also desirous of being liberated from the narrow circle of ideas within which it had been confined for ages. The human race advanced perceptibly towards the point of maturity of a new epoch. A change in the order of things, an approaching commotion, seemed at hand: a rumbling was heard in the bowels of the volcano; ardent vapors burst forth and streamed through the obscurity. Such was the menacing fermentation which appeared in the political state of nations from the commencement of the sixteenth century. The minds of men had undergone a great change; worship had become the business of the senses and religion a mythology; splendid ceremonies had superseded simple prayers; saints and images became the intercessors with an almost forgotten God, and the immediate objects of devotion. The populace and the ignorant adhered very strongly to this system of superstition, which captivated their senses and lulled all their vices. But he who began to think and to examine would perceive, amid all this pomp and ceremonial observance,

only the work of man's hand; he would at once, and entirely, reject a system in which he could no longer discover any trace of true religion.

Advancing to the period of the German reformation we find that the first attack on the church of Rome commenced in 1517 on the part of Martin Luther, who, on the 30th of September, delivered ninety-five propositions, in which he censured, in the boldest manner, the extravagant conduct and extortion of the papal commissioners for the sale of indulgences. These propositions were promulgated at Wittemberg, at the college of which he was doctor. Ignorant of a stipulation made between Leo X. and Albert of Brandenburg, by which the latter should retain one half of the profits arising from the sale of these indulgences, Luther addressed a letter of remonstrance to this elector; but, as might naturally have been supposed, no regard was paid to his complaints. Exasperated by this neglect, he next published to the world the propositions he had read in the church in Wittemberg. They contained many censures on the pope himself, but were rendered as palatable as possible by repeated expressions of obedience to the papal authority and the doctrines and decisions of the church. On the first appearance of these propositions Tetzel, the principal vender of the indulgences by the appointment of the elector of Mentz, endeavoured to defend a traffic in which he had so much personal interest. To effect this purpose, he published a set of counter propositions, and then publicly burned those by Luther. The friends of Luther, in a similar spirit, rejoined, by burning 800 copies of Tetzel's propositions in one of the public squares of Wittemberg. This conduct Luther had the moderation or good sense to lament; and he affirmed that it was adopted without his knowledge.

Leo X., confiding in the professions of Luther, who had declared to him 'that he would regard whatever came from him as delivered by Christ himself,' took no immediate steps to curb the zeal of the reformers, nor to remove the cause of their just complaints. At length, however, the indolent pontiff was roused from his danger; and, in 1518, he summoned Luther to appear before him at Rome, within sixty days, there to answer the questions which should be proposed to him by Prierio, his virulent opponent. It required no extraordinary degree of penetration to perceive what must be the issue of the trial, wherein the judge and the plaintiff were one and the same person. Accordingly Luther made sufficient interest to have his cause heard in Germany. Tomaso de Vio, cardinal of Gaeta, the pope's legate at the diet of Augsburg, was empowered to summon Luther before him; and, if he should persist in his errors, to hold him in custody till farther instructions should be sent from Rome. It was of small consequence to Luther whether his cause should be heard before the prejudiced and interested Prierio at Rome or by the equally interested Dominical cardinal of Gaeta, in Germany. Whatever might have been the lenient principles at first cherished by the pope, this precipitate and rash determination gave great and just cause of offence to Luther and his friends. No alternative, however, re-



mained; and Luther, having obtained with great difficulty and delay a safe conduct from the emperor, repaired to Augsburg. Previously, however, to this, and after the pope had sent his monitory to the cardinal of Gaeta, a power had been delegated to that cardinal to hear his defence, and, in case of penitence and submission, again to receive him to the communion of the faithful. Encouraged by several powerful and determined patrons, Luther contemned the authority of the legate; and refused to make any concessions, or to violate his conscience, as he termed it, by disavowing what he knew to be the truth. He yielded, however, so far as to consent that his opinions should be submitted to such universities as he should name; and promised in future to desist from impugning the discipline of indulgences, provided his adversaries were likewise to be silent concerning them. Luther, after different meetings, was permitted to depart; when his friends judging from the bold or rash manner of his proceeding, and the known authority of his adversaries, that it would not be prudent for him to remain any longer in danger, advised a secret flight from Augsburg. Prior, however, to his departure, he published a solemn appeal from the supreme pontiff prejudiced and misled to the same pontiff when better informed. The abrupt departure of Luther from Augsburg naturally awakened the resentment of the cardinal, and he immediately addressed a letter to the elector of Saxony, to whose protection Luther fled, expressing his surprise and indignation at his conduct, at the same time requesting that, if he should continue to hold and defend his opinions, he might be sent to Rome, or at least banished from the elector's dominions. Frederick, the elector, replied in a respectful manner to the legate's letter, but refused to condemn Luther before his opinions were proved to be erroneous. Every day increased the danger to which Luther was exposed by his intrepid zeal and perseverance; but the power claimed by Leo X., in a bull he had just issued, reduced him to this most difficult alternative—either openly to acknowledge, as he had ever done, his perfect obedience to the holy see, by submitting his judgment to the decisions of the pope; or at once renounce obedience to the vicar of Christ, and declare open war against the whole Christian world. With a boldness unparalleled, he resolved on the latter, and immediately appealed from the pope to a general council. He was then at Wittemberg. To justify himself in this measure, he truly declared that general councils 'are superior in power to the pope, who, being a fallible man, might err, as St. Peter, the most perfect of his predecessors, had erred.' He further remarked that the prophet forbids us to put our trust or confidence in man, even in princes, to whose judgment nothing ought less to be committed than the words of God; protesting, however, at the same time, that he had no intention to speak any thing against the holy catholic and apostolic church, nor against the authority of the holy see. Leo X., still unwilling or afraid to push matters to extremities against this unruly son of the church, addressed a conciliatory message to the elector of Saxony. This was accompanied by

a present which a very short time before would have had the most pleasing effects on the mind of the elector: it was the consecrated rose, which the pontiff had been in the habit of sending annually to those princes for whom he professed a more than usual affection and regard. This sacred and honorable present came too late. The rose had lost its fragrance with the half reformed elector.

VI. *Decisive progress of the Reformation in Germany.*—About this period Andrew Bodenstein, called by himself Carlostadt, from the place of his birth, having embraced the opinions of Luther, published a thesis in their defence. This called forth the learning and powerful abilities of Eckius. To enter into a detail of the disputes at Leipsic between Eckius, Carlostadt, and Luther, would neither edify the reader nor illustrate the history. As usual both sides claimed the victory: before they entered upon the debate, which was conducted in the hall of the castle at Leipsic, in the presence of George, duke of Saxony, and a large concourse of other eminent persons, Eckius proposed to appoint suitable judges. Luther, with his characteristic boldness and impetuosity, replied that all the world might be the judge. If, however, these disputes had but little effect, while they were carried on by both parties in propria persona, when they were renewed in writing they called forth the efforts of many learned and eminent scholars; amongst whom were Melancthon and Erasmus, whose various publications awakened the spirit of enquiry, and forwarded, in a very powerful manner, the cause of the Reformation. After the fruitless disputes at Leipsic, Luther returned to Wittemberg, where Miltitz renewed his efforts to reconcile Luther to the pope and the church; and prevailed upon him, by calling in the assistance of the society of the Augustine monks, to which Luther belonged to write again to the pope, with a further and more explicit account of his conduct. Under the pretext of obedience, respect, and even affection for the pontiff, Luther conveyed the most determined opposition, the most bitter satire, and the most marked contempt; insomuch that it is scarcely possible to conceive a composition more replete with insult and offence than that which Luther affected to allow himself to be prevailed on to write by the representations of his own fraternity. After justifying the asperity with which he had commented on the misconduct of his adversaries, by the example of Christ and of the prophets and apostles, he thus proceeds: 'I must, however, acknowledge my total abhorrence of your see, the Roman court, which neither you nor any man can deny is more corrupt than either Babylon or Sodom, and according to the best of my information is sunk in the most deplorable and notorious impiety. For what has Rome poured out for many years past (as you well know) but the desolation of all things, both of body and soul, and the worst examples of all iniquity. It is indeed as clear as daylight to all mankind that the Roman church, formerly the most holy of all churches, is become the most licentious den of thieves, the most shameless of all brothels, the kingdom of sin, of death, and of

hell: the wickedness of which not antichrist himself could conceive. The fate of the court of Rome is decreed; the wrath of God is upon it; advice it detests; reformation it dreads; the fury of its impiety cannot be mitigated, and it has now fulfilled that which was said of its mother: 'We have medicined Babylon and she is not healed; let us therefore leave her.' It was the office of you and your cardinals to have applied a remedy; but the disorder derides the hand of the physician, 'nec audit curus habenas.'

Had the friends of the Roman court viewed this in the light in which some protestants have considered it, and not in fact completing 'the measure of his offences' against the pope and the holy Catholic church, the bull of excommunication which Leo X. unwillingly issued against the author of it, would never have been put in force. Luther and his adherents are conjured in it to return to their duty, and renounce their errors; assuring them, that if they give manifest proof of their obedience, by destroying and disavowing their writings within six days, they should be graciously received to the bosom and protection of the church; but that, should they persist in their errors and contumacy, after the time specified, they should be proceeded against immediately as obstinate and perverse heretics, and receive the punishment which the law, in such cases, has provided. The bull of Leo X., instead of allaying these tumults, called forth all the zeal and energy of Luther, and his powerful and numerous friends. To such a pitch of exasperation did this measure raise the intrepid and daring innovator, that he threw off, in the most unequivocal manner, all forms of respect, and even decency, towards the pope, the councils and the Catholic church. Refusing to appear to the pope's citation, he boldly exclaimed, 'I defer my appearing there until I am followed by 5000 horse and 20,000 foot; then will I make myself believed.' No epithet of a severe and offensive nature was spared in representing the character and conduct of the pope and his whole court. He once more appealed to a general council, and hesitated not to call the supreme pontiff, the lord, whose authority he had lately declared as inferior only to that of Jesus Christ, a tyrant, a heretic, an apostate, and antichrist, himself. He even summons the pope and his cardinals to repent of their sins and renounce their errors, or he would otherwise deliver over both them and their bull, with all their decretals, to Satan, that by the destruction of the flesh, their souls may be liberated in the coming of our Lord.

Not being in a capacity to carry his threat into execution in any other way, 'on the 10th of December 1520, he caused a kind of funeral pile to be erected without the walls of Wittemberg, surrounded by scaffolds, as for a public spectacle; and, when the places thus prepared were filled by the members of the university and the inhabitants of the city, Luther made his appearance with many attendants, bringing with him several volumes containing the decrees of Gratian, the decretals of the popes, the constitutions called the *Extravagants*, the writings of Eckius, and of Emser, another of his antagonists, and,

Vol. XVIII.

finally, a copy of the bull of Leo X. The pile being then set on fire, he, with his own hands, committed the books to the flames, exclaiming at the same time, 'Because ye have troubled the holy of the Lord, ye shall be burnt with eternal fire.' That there might be no mistake respecting the real sentiments of these zealous reformers, on the following day Luther mounted the pulpit and openly declared that the conflagration they had just seen was a matter of small importance; that it would be more to the purpose if the pope himself, or, in other words, the vernal see, were also burnt.

Every one must allow to Luther the merit of uncommon fortitude, zeal, and constancy. This was manifested in a conspicuous manner at the diet of Worms, which was assembled early in the year 1521, by the emperor Charles V. To this assembly Luther was summoned to appear, and he did not hesitate promptly to obey the summons, declaring to his friends, who were alarmed for his safety should he comply, that were he sure to encounter there as many devils as there were tiles on the houses, he would not disobey the call. He arrived at the city of Worms on the 16th of April, attended by a numerous and splendid retinue, and was conducted to the diet on the following day by the marshal count Pappenhem, who informed him that he would not be permitted to address the assembly, but must give unequivocal answers to such questions as should be put to him. Being asked whether the books published in his name, the titles whereof were recited to him, were indeed his own publications; and, also, if they were, whether he was prepared to retract what had been condemned by the pope's bull in them: He replied, that certainly the books were his, and that he should never deny them; but that with respect to retracting any thing he had advanced in those books, it was a matter of such importance, that he requested a little time to consider before he gave his answer. Accordingly he was allowed till the following day to deliver a verbal and decided resolution. Encouraged by the plaudits and the advice of numerous friends, and urged on to constancy by the admiration of the populace, he again appeared before the diet at the time appointed. He delivered a very long and eloquent oration, in which he declared that some of his writings being published purely for the promotion of piety and good morals, he could not be expected to condemn what both friends and enemies allowed to be useful and innocent;—that others being directed principally against the tyranny of the papistical doctrines, which had given such general offence, he could not retract them without betraying the cause of liberty and truth, which he had hitherto resolved to support;—but that with respect to the third portion of his writings, which were those written directly against his various adversaries, he would confess he might have departed from that strict line of mildness and decorum which he ought to have observed; and that as he made no extraordinary pretensions to sanctity, and was rather disposed to defend his doctrines than his manners, he should only reply in the words of the Saviour, 'If I have spoken evil, bear witness of the evil.'

2 G

This was the only concession he appeared disposed to make, except that, if any of his doctrines could be proved to be opposed to the holy Scriptures, he himself would be the first to commit them to the flames. Addressing himself immediately to the emperor and the other princes who were present, he said that the true doctrine, when publicly acknowledged, was, at all times, to be regarded as a divine blessing; but that to reject it would infallibly bring upon them many serious calamities. This harangue not being deemed a satisfactory answer, it was demanded of him to say, simply and unequivocally, whether he would or would not retract his opinions and writings. Now it was that all the native greatness and dignity of his soul became manifest, and he boldly replied in the following terms, as translated by Mr. Roscoe:—'Since your majesty, and the sovereigns now present, require a simple answer, I shall reply thus, without evasion and without vehemence. Unless I be convinced by the testimony of Scripture, or by evident reason (for I cannot rely on the authority of the pope and councils alone, since it appears they have frequently erred and contradicted each other), and unless my conscience be subdued by the word of God, I neither can nor will retract any thing, seeing that to act against my own conscience is neither safe nor honest.' After which he added, in his native German, for he had previously spoken in Latin, 'Hier stehe; ich gan nicht anders; Gott helff mir, Amen.' 'Here I take my stand; I can do no other; God be my help! Amen.' Never through his whole life did Luther appear to so much advantage as on this memorable occasion. The answer which Luther had given to the diet seemed to have placed the matter beyond all further dispute, and that nothing remained but to put the law against heretics in force upon him; yet, through much persuasion, the emperor was induced to allow him to remain three days longer at Worms, and in the mean time several persons were permitted to use their best efforts in private to persuade him to obedience. But, every mild and lenient method proving abortive, he was commanded to depart from the city and not to be found within the emperor's dominions after the expiration of twenty days. Some persons even advised the emperor to disregard the safe conduct which had been granted, and, imitating the council of Constance, to destroy at once so dangerous a heretic; but to the eternal honor of Charles V. he replied, that he would not give himself occasion to blush as the emperor Sigismund had done, in the case of John Huss. In thus nobly refusing to depart from the spirit of his religious profession, he was encouraged by Louis, the elector count Palatine, who declared that such an act would brand the German name with perpetual infamy; and added that it was intolerable that the empire should be for ever disgraced and reproached for not keeping the public faith merely to gratify the resentment of a few priests. Luther left the city of Worms on the 26th of April, accompanied by the imperial herald. He was met at the gate of the city by a numerous body of his friends, from whom he received the warmest congratulations and applause; he then proceeded on his jour-

ney to Wittemberg. On the 26th of May, one month after his departure, the emperor, after repeated solicitations, issued a decree of the diet against him, in which he is represented 'as the devil in the semblance of a man, and the dress of a monk;' and all the subjects of the imperial dominions are required to seize upon him and his adherents, to destroy their property, and burn their books and writings; and all printers are forbid to publish any of their works without the consent of the ordinary. Luther, however, escaped the rage of his enemies, by a very fortunate and unlooked-for circumstance. Passing through a wood on his way to Wittemberg, with but a small band of attendants, he was seized by several persons in masks, employed by the elector of Saxony, and forcibly carried to the castle of Wartburg, where he remained in privacy for the space of nine or ten months, during which Leo X. died, and was succeeded by Adrian VI. This master piece of policy and humanity in Frederick was attended by several beneficial effects. During this retreat Luther employed himself in composing many of those works which have since become, in a manner, the ground-work of the Reformation. Here, also, he translated a great part of the New Testament into the German language, and wrote numerous letters to various parts; so that the work of the Reformation went on with a rapidity equal to his most sanguine wishes, notwithstanding the opposition it met with from the apostolic nuncios and others.

From this period the Reformation may properly be said to have taken effectual root. The subject which now chiefly engaged public attention was the expected call of a general council. The reformed party was solicitous for the measure, in the hope of reducing the prerogative of the pontiff; while the moderate and well-intentioned part of the Catholics looked to it as the means of stopping the farther progress of schism. After many delays the unsteady and irresolute Clement had at last declared his assent to the long expected convocation. Whether he was sincere in this declaration, or as is more probable meant only an apparent concession to the wish of the German diet, the occurrence of his death, in the midst of the negotiation, has left a matter of uncertainty. Alexander Farnese, to whom Clement had, in a manner, bequeathed the pontificate, succeeded him without opposition, and assumed the name of Paul III.

Paul proceeded, or affected to proceed, on the plan of making arrangements for the convocation of a council. But, as the reformed were now too numerous to be refused access to the council, Paul determined, as a preliminary step, to despatch a confidential person to confer with their leading men. His nuncio in Germany, Peter Paul Verger, a native of Istria, and a favorite of Paul's predecessor, was chosen for this commission. This person proceeded to Wittemberg to meet Luther. The interview was terminated, as might be expected, without any beneficial result. The pope now ordered his legate to declare to the diet of Spires, assembled in 1542, that he would, according to the promise he had already made, assemble a general council, and that Trent should be the place of its meeting, if the diet had no

objection to that city. Ferdinand and the princes who adhered to the cause of the pope gave their consent to this proposal; but it was vehemently opposed by the protestants, both because the council was summoned by the authority of the pope only, and also because the place was within his jurisdiction, while they desired a free council, which should not be biased by the dictates nor awed by the proximity of the pontiff. But this protestation produced no effect. Paul III. persisted in his purpose, and issued out his circular letters for the convocation of the council with the approbation of the emperor.

The emperor labored to persuade the protestants to consent to the meeting of the council of Trent; but, when he found them fixed in their opposition to this measure, he began to listen to the sanguinary measures of the pope, and resolved to terminate the disputes by force of arms. The elector of Saxony and Landgrave of Hesse, who were the chief supporters of the protestant cause, upon this took proper measures to prevent their being surprised and overwhelmed by a superior force. But, before the horrors of war commenced, the great reformer Luther died in peace at Eisleben, his native place, February 14th, 1546. He had travelled to Eisleben from Wittemberg in the midst of winter, to endeavour to effect a reconciliation between the counts of Mansfield. Soon after entering Eisleben, he suffered an access of extreme debility, a circumstance not unusual with him in engaging in a matter of deep interest. But this attack was more serious than on former occasions. He recovered, however, and seemed to enjoy the hospitality which his friends were anxious to show him. His time was passed in attention to his customary hours of daily prayer; in the transaction of the business which had called him to Eisleben; and in cheerful and good humored conversation. He partook twice of the Lord's Supper, and preached three or four times before the progressive advance of his malady led to the exhaustion of his frame; after passing nearly three weeks at Eisleben, his illness was productive of a fatal termination, Luther expired, surrounded by friends, and placing the fullest trust in Him to the promotion of whose cause he had zealously and constantly devoted his powers. To the eternal honor of Luther we may add, that after having refused the offers of the court of Rome; after having been so many years the father and almost the founder of a new church; after having been the friend, the adviser, the spiritual father of so many princes, who, through the Reformation, had been enriched with all the possessions of the clergy, of which he might if desirous have obtained a rich share, he lived and died in a state bordering on poverty, and left to his wife and children only the esteem due to his name. In the diet of Augsburg, which was soon after called, the emperor required the protestants to leave the decisions of these religious disputes to the wisdom of the council which now met at Trent. See TRENT.

A plague which broke out, or was said to do so, in the city of Trent, caused the greater part of the bishops to retire to Bologna; by which means the council was in effect dissolved, nor

could all the entreaties and remonstrances of the emperor prevail upon the pope to reassemble it without delay.

In the year 1549 Paul III. died, and was succeeded by Julius III., who, at the repeated solicitations of the emperor, consented to the reassembling of a council at Trent. A diet was again held at Augsburg under the cannon of an imperial army, and Charles laid the ecclesiastical affairs before the princes of the empire. On the dissolution of this meeting, in 1551, the emperor Charles V., being defeated at Inspruck, concluded a treaty with Maurice, elector of Saxony at Passau, which is considered by the protestants as the basis of their religious liberty. By this treaty it was provided that another diet should be called with a view to an amicable adjustment of all matters in dispute, and that until such adjustment the contending parties should enjoy the free and undisturbed exercise of their religion. Various circumstances delayed the promised meeting of the diet; at length, however, it met at Augsburg, where it was opened by Ferdinand in the name of the emperor, and terminated those deplorable calamities which had so long desolated the empire. After various debates the following resolutions were agreed to on the 25th of September 1555; that the protestants who followed the confession of Augsburg should be, for the future, considered as entirely free from the jurisdiction of the Roman pontiff, and from the authority and superintendance of the bishops; that they were left at perfect liberty to enact laws for themselves relating to their religious sentiments, discipline, and worship; that all the inhabitants of the German empire should be allowed to judge for themselves in religious matters, and to join themselves to that church whose doctrine and worship they thought the most pure and consonant to the true spirit of Christianity; and that all those who should injure or persecute any person under religious pretences, and on account of their opinions, should be declared and proceeded against as public enemies of the empire, invaders of its liberty, and disturbers of its peace. Thus was the Reformation established in several of the states of the German empire, where it continues to this day; nor have the efforts of the papacy been since able to suppress it, or even to prevent its growth.

VII. *Progress of the Reformation in England.*—Turning from Germany the cradle of the Reformation, and from those holy men to whom under God we owe the first revival of truth and science on the continent, the pious and Christian mind will delight to contemplate the various causes which were preparing the way in England for a religious revolution not less remarkable nor less beneficial than that effected by Luther. The growing cruelty, oppression, and ignorance of the clergy had already excited the just hatred of the people to no small extent; but the enemies whom the wealth of the church tempted to assail it were far more dangerous than those who opposed its corrupt doctrines and superstitious practices. When, however, its wealth had once become an object of cupidity to the government, the enemies whom its corruption

had provoked, and its cruelties incensed, were ready to league with any allies against it, and reform and spoliation went hand in hand. The accession of Henry VIII. to the throne of England promised to the world a reign of splendor, popularity, and peace. With every advantage of person, he united a high degree of bodily and mental accomplishment; his understanding was quick and vigorous; and his learning such as might have raised him to distinction, had he been born in humble life. Among the passions of Henry must be reckoned that which he had for the writings of St. Thomas Aquinas. His veneration for this vigorous champion of the Roman orthodoxy was carried so far that, Luther having contradicted St. Thomas with acumen, Henry thought himself bound to enter the lists and defend his master. He, therefore, wrote a Treatise, or Assertion of the Seven Sacraments, against Luther, who admitted with all the reformed churches of no more than two. The latter treated his new adversary as his equal, and ridiculed him; but the pope, who perhaps really laughed at the book as much as Luther did, appeared so much delighted with his literary efforts in his favor, that he bestowed on Henry the title of 'defender of the faith.' Little did the world imagine that Henry was so soon to become one of the most potent enemies of the papacy; and that the Reformation under his auspices would be introduced into England. A speech of the court fool upon that occasion has been preserved: 'O, good Harry, let thou and I defend one another, and let the faith alone to defend itself.' Henry had now been married eighteen years to Catherine of Arragon, who had been brought over from Spain to marry his eldest brother, prince Arthur, who died some months after his cohabitation with her. Henry had three children by this lady, one of whom was still living, while she herself was esteemed for her virtue and the gentleness of her disposition. It happened at length, that among the maids of honor that then waited on the queen, his attention was attracted by Anna Bullen, the daughter of a gentleman of distinction, though not of the nobility. The king, who never restrained one passion which he desired to gratify, saw and loved her; but, after several efforts to induce her to comply with his criminal passion, he found that without marriage he could have no hopes of succeeding. This obstacle, therefore, he undertook to remove; his own queen was now become hateful to him, and, in order to procure a divorce, he pretended his conscience rebuked him for having so long lived in incest with his present queen, formerly his brother's wife. In this perplexity, therefore, he applied to Clement VII., who owed him obligations, and from whom he expected a ready compliance, to dissolve the bull of the former pope, who had given him permission to marry Catherine, and to declare it was contrary to all laws both divine and human. Clement was now in the utmost perplexity. Queen Catherine was aunt to the emperor, who had lately made him a prisoner, and whose resentment he dreaded to rekindle, by thus injuring so near a relation; besides he could not, in honor, declare

the bull of the former pope illicit, for this would be entirely destroying the papal infallibility. On the other hand, Henry was his protector and friend, the dominions of England were the chief source of his finances; and the king of France, some time before, had got a bill of divorce in somewhat similar circumstances. In this exigence he thought the best method was to spin out the affair by negotiation; whilst it depended, he was sure of two great friends, but, when it should be decided, of one great foe: and thus he argued, temporised, promised, recanted, and disputed, hoping that the king's passion would never hold out during the tedious course of an ecclesiastical controversy, or that the not improbable death of the queen, or some other of those accidents to which human affairs are subject, might extricate him from his embarrassment. During the negotiations, on which Henry's happiness seemed to depend, he expected, in his favorite Wolsey, a warm defender, and a steady adherent; but Wolsey seemed to be in almost as great a dilemma as the pope himself. On the one hand he was to please his master, the king, from whom he had received a thousand marks of favor; on the other hand he could not disoblige the pope, whose servant he more immediately was, and who had power to punish his disobedience. The king's resentment was consequently excited against the cardinal, who died soon after, in all the pangs of repentance and remorse.

Henry, by the advice of Cranmer, had the legality of his present marriage canvassed in the different universities of Europe. Almost all the colleges of Italy and France declared his present marriage against all law, divine and human; and that, therefore, it was not, at first, in the power of the pope to grant a dispensation. Among the places where it was most warmly opposed were Cambridge and Oxford; but, at last, they also concurred in the same opinion. Thus fortified, the king was resolved to oppose even the pope himself, for his passion could by no means brook the delays and subterfuges of the holy see; being therefore supported by his clergy, and authorised by the universities; having seen the pope formerly degraded by a lay monarch, and Luther's doctrine followed by thousands; and yet still further instigated by the king of France, he, without further dispensation, annulled his marriage with queen Catherine; and Cranmer, now become an archbishop, pronounced the decree.

The pope now thought himself obliged to hold no measures with the king; and, therefore, published a sentence declaring queen Catherine alone to be Henry's lawful wife, and requiring him to take her again, with a denunciation of censures in case of refusal. Henry, enraged that the pope should dare to thwart his passion, declared himself at once head of the church of England, and prohibited all intercourse with Rome; the tribute of Peter-pence, and the interference of the pope in the collation to benefices. The people came into the king's proposal with joy, and took an oath, called the oath of supremacy; all the credit of the pope, that had subsisted for ages, was now at once over-

thrown, and few, except those who held to the religious houses, seemed dissatisfied. In this manner began the Reformation of England, and by such surprising methods providence brought about its designs.

Henry was very sensible that the parliament was, even from motives of interest, entirely devoted to him, and therefore he was resolved to make use of the opportunity, and render himself absolute. Being empowered to act as he thought proper, he went vigorously to work in the suppression of monasteries, colleges, and religious houses. To reconcile the people to these proceedings, Henry took care to have the counterfeit reliques exposed, the scandalous lives of the friars and nuns made public, and all their debaucheries detected. Whatever had served to engage the people in superstition, was publicly burnt; but what grieved the people most to see, were the bones of Thomas Becket, the saint of Canterbury, burnt in public, and his rich shrine, in which there was a diamond of great value, confiscated among the common plunder. But, though the king had entirely separated himself from Rome, yet he was by no means willing to be a follower of Luther. The invocation of saints was not yet abolished by him, but only restrained; he ordered the Bible to be translated into the vulgar tongue, but not put into the hands of the laity. The publication of Tindal's Translation of the Bible was at this time, in its effects upon this nation, the most important volume that ever issued from the press. Under the patronage of Humphrey Monmouth, a wealthy and benevolent citizen, Tindal travelled into Germany, where he conferred with Luther and others of the great protestant divines, and then settling at Antwerp, as the best place for printing his book and securing its transmission to England, completed the New Testament. Tindal had perceived, he said, that it was impossible to establish the people in any truth, except the Scriptures were plainly laid before them in their mother tongue, that they might see the process, order, and meaning of the text. The Romanists understood perfectly well how little the practice of their church was supported by Scripture; and that, if the ark of the covenant was admitted, Dagon must fall. No sooner therefore was it discovered that copies of this translation were industriously dispersed in England than it was prohibited, as being corrupted with articles of heretical pravity, and opinions erroneous, pernicious, pestilent, and scandalous; tending to seduce persons of simple and unwary dispositions; but a spirit had now been roused which no persecution could suppress; the book was therefore eagerly sought for and widely dispersed.

It was a capital crime to believe in the pope's supremacy, and yet equally heinous to be of the reformed religion, as practised in Germany. Henry's opinions in religion were delivered in a law, which, from its horrid consequences, was termed the bloody statute, by which it was ordained that whoever, by word or writing, denied transubstantiation, that whoever maintained that the communion in both kinds was necessary, or that it was lawful for priests to marry,

or that vows of chastity could innocently be broken, or that private masses were unprofitable, or that auricular confession was unnecessary, should be burnt or hanged as the court should determine. The kingdom, at that time, was in some measure divided between the followers of Luther and the adherents to the pope; this statute, with Henry's former decrees, in some measure excluded both, and therefore opened a wide field for persecution. Children were now compelled to accuse their parents and parents their children, wives their husbands and husbands their wives, unless they would share the same fate. The poor wretches, who saved their lives by abjuration, were, under the name of perpetual penance, condemned to perpetual bondage, being distributed to monasteries beyond the precincts of which they were never to pass, and where by their labor they were to indemnify the convent for their share of such food as was regularly bestowed as charity at the gate. The mark of the branding iron they were never to conceal; they were to bear a faggot at stated periods, and once at the burning of a heretic; for which every one who contributed a faggot was rewarded with forty days indulgence.

Among the martyrs of those days, Thomas Bilney is one whose name will ever be held in deserved reverence. He had been brought up from a child at Cambridge, where, laying aside the profession of both laws, he entered upon what was then the dangerous study of divinity; and being troubled in mind repaired to priests, who enjoined him masses, fasting, watching, and the purchase of indulgences, till his scanty purse and feeble constitution were both well nigh exhausted. At this time hearing the New Testament, which Erasmus had just published, praised for its Latinity, he bought it for that inducement only; and opened it upon a text, which finding his heart open, rooted itself there: 'This is a faithful saying and worthy of all acceptance, that Christ Jesus came into the world to save sinners, of whom I am chief.' The comfort which these words conveyed was confirmed by the frequent perusal of a book which now became sweeter than honey, or the honeycomb; and he began to preach, as he had learnt, that men should seek for righteousness by faith. It was not long before he was accused before Cuthbert Tonstal, then bishop of London, a man of integrity and moderation, though compelled to bear a part in proceedings which were utterly abhorrent to his natural disposition. The main accusations against him were, that he asserted Christ was our only mediator, not the Virgin Mary, nor the saints; that pilgrimages were useless; and that offerings to images were idolatry. Of these doctrines he was found guilty; the sheriff, to whose custody he was delivered, happened to be one of his friends, and therefore treated him with every kindness which could be afforded during his imprisonment. The night before he was to suffer some friends who visited him found him at supper eating heartily, and with a cheerful countenance; and one of them saying he was glad to see him refresh himself thus so shortly before he was to undergo so painful a death, he replied, 'I follow

the example of those, who, having a ruinous house to dwell in, hold it up by props as long as they may:’ another observed that his pains would be short, and the spirit of God would support him in them, and reward him afterwards with everlasting rest. Bilney, upon this, put his finger into the candle, which was burning before him more than once. ‘I feel,’ said he, ‘by experience, and have long known by philosophy, that fire is naturally hot; yet I am persuaded by God’s holy word, and by the experience of some saints of God therein recorded, that in the flames they may feel no heat, and in the fire no consumption. And I constantly believe that, however the stubble of this my body shall be wasted by it, yet my soul and spirit shall be purged thereby—a pain for the time,—whereon followeth joy unspeakable;’ and then he repeated the words of Scripture: ‘Fear not, for I have redeemed thee, and called thee by thy name; thou art mine own; when thou goest through the water, I will be with thee, and the strong floods shall not overflow thee. When thou walkest in the fire, thou shalt not be consumed, and the flame shall not burn thee; for I am the Lord thy God, the Holy One of Israel, thy Saviour.’ This text he applied to himself and those who were present, some of whom, remembering the words as a legacy of a blessed martyr, had them fairly written on tables, or in little books, and derived comfort from them till their dying day. On the following morning he was led to execution, one of his friends exhorting him at the prison door, with few and secret words, to take his death patiently and constantly. Bilney answered, ‘When the mariner is tossed upon the troubled sea, he beareth his perils better, in hope that he shall yet reach his harbour; so, whatever storms I shall feel, my ship will soon be in its quiet haven; thereof, I doubt not, by the grace of God,—and I entreat you, help me with your prayers, to the same effect.’ The place of execution was a low valley, surrounded with rising ground, without the bishop’s gate. Having put off the layman’s gown, in which after his degradation he had been clad, he knelt upon the sledge, and prayed with deep and quiet devotion, ending with the 143d Psalm, in which he thrice repeated the verse, ‘Enter not into judgment with thy servant, O Lord, for in thy sight shall no man living be justified.’ He then put off his jacket and doublet, and remained in his hose and shirt, and so was chained to the stake. The dry reeds were kindled; and in a few minutes Bilney, triumphing over death, rendered up his soul, in the fullness of faith, and entered into his reward.

Those who adhered to the pope, or those who followed Luther, were now equally the objects of royal vengeance and ecclesiastical persecution. In the houses of parliament, parties were nearly equally divided; there were on both sides men of great learning, ability, and address. After long consultation and debate certain articles were at length set forth in the king’s name as head of the church of England; it being in the preamble stated, ‘among the chief cares appertaining to his princely office, diligently to provide that unity and concord in religious opi-

nions should increase and go forward; and all occasion of dissent and discord, touching the same, be repressed and utterly extinguished.’ The articles were such as could satisfy neither party, both having struggled to introduce their own opinions, and each with considerable success, though on the whole to the manifest advantage of the reformers. The Bible and the three creeds were made the standards of faith, no mention being made of tradition, nor of the decrees of the church. Three sacraments—those of baptism, penance, and the altar—were said to be necessary to salvation—four being thus pretermitted; but the corporal presence was declared, and the necessity of auricular confession. Images were allowed as useful, but they were not to be worshipped; and saints might laudably be addressed as intercessors, though it was asserted that Christ is our only sufficient mediator. The existing rites and ceremonies were to be retained as good and laudable; not as having power to remit sin, but as useful in stirring and lifting up our minds unto God, by whom only our sins can be forgiven. Lastly, prayers for the dead were advised as good and charitable; though the question of purgatory was said to be uncertain by Scripture, and the abuses which under that belief had arisen were to be put away. Thomas Cromwell, raised by the king’s caprice from a blacksmith’s son to be a royal favorite, and Cranmer, now become archbishop of Canterbury, with all their might assisted the Reformation. The pope had long threatened to issue a bull of deposition, but had hitherto delayed it because of the displeasure which he knew it would occasion to other sovereign princes. The manner in which Becket had been uncanonised put an end to this suspension; and the bull was now fulminated, requiring the king and his accomplices to appear at Rome, and there give an account of their actions on pain of excommunication and rebellion, otherwise the pope deprived him of his crown, and them of their estates, and both of Christian burial. He interdicted the kingdom; absolved his subjects and their vassals from all oaths and obligations to them; and offered his dominions to the king of Scotland, if he would go and take them. But the throne of England was no longer to be shaken by such thunders. Even the Romish bishops joined in the declaration which Henry set forth, that Christ had forbidden his apostles or their successors to take to themselves the power of the sword, or the authority of kings; and if the bishop of Rome, or any other bishop, assumed any such power, he was a tyrant and usurper of other men’s rights, and a subverter of the kingdom of Christ.

At length so many hundred persons were thrown into prison upon the six articles, that Henry himself thought it better to grant a general pardon, than to proceed against them all; and this bloody act slept till his determination to put away Anne of Cleves, and marry Catherine Howard, drew on the fall of Cromwell, whom the duke of Norfolk, uncle to the bride elect, mortally hated. Now the six articles were enforced with extreme severity; and Henry as if to show his impartiality while he executed as

heretics those reformers who went beyond the limits which he had laid down, put to death as traitors those Romanists who refused to acknowledge his supremacy.

The alterations in the reign of Henry were rather separations from the pope than a reformation of religious abuses: in the reign of his successor, Edward VI., the errors of Rome, in reality, began to be reformed. It was left to people's choice to go to confession, which had hitherto been deemed an indispensable duty, or to neglect that practice. It was ordered that all images should be taken out of churches; priests were allowed to marry; the old mass was abolished; and a new liturgy drawn up, which retrenched several abuses in the service of the church, and which is the same with that now used, excepting a few alterations. Gardiner and Bonner, refusing their consent to these momentous changes, were deprived of their sees and imprisoned; but no rigor was used towards them, nor did the protestants in any instance abuse their triumph by retaliating upon the papists for the persecution which they had endured. Immediately upon the death of the young king, two competitors put up for the crown; Mary relying upon the justness of her pretensions, and the lady Jane Grey supported by the duke of Northumberland, her father-in-law. Mary was strongly bigoted to the popish superstitions. Her zeal had rendered her cruel, and she was not only blindly attached to her religious opinions, but even to the popish clergy who maintained them. On the other hand, Jane Grey was attached to the reformers; though yet but sixteen, her judgment had obtained such a degree of perfection as few enjoy in their more advanced age. Queen Mary, however, obtained possession of her rightful throne without the loss of a single life; so completely did the nation acknowledge her claim, whilst an after insurrection rashly planned, and worse conducted, served only to hasten the destruction of the lady Jane and her husband. Mary began by giving orders for the suppression of all married bishops and priests; the mass was directed to be restored; the pope's authority was re-established with some restrictions; the laws against heretics were renewed; and the church and its privileges put on the same foundation in which they were before the alteration of Henry VIII. This was kindling up the fires of persecution anew; at the head of these measures were Gardiner bishop of Winchester, and Bonner bishop of London. Gardiner began this bloody scene with Hooper and Rogers. Hooper had been bishop of Gloucester; Rogers was a clergyman who had shone among the most distinguished of the protestants. He was prebendary of St. Pauls, and refused all submission to the church of Rome, which he looked upon as antichristian. They were both condemned by the commissioners appointed by the queen, with the chancellor at the head of them. Rogers suffered in Smithfield. When he was brought to the stake he had it in his power to save himself, by recanting his opinions; but neither hopes nor fears could prevail on him to desert his religion. When the faggots were placed around him he seemed no

way daunted at the preparation, but cried out, 'I resign my life with joy, in testimony of the doctrine of Jesus;' and washing his hands in the flames, as they blazed around him, took his death with so calm and resolute a patience, that many who were present blessed God for the support which had been vouchsafed him. Hooper had his pardon offered him upon the same terms, but he refused it with equal indignation. This old martyr, who was executed at Gloucester, was three-quarters of an hour in torment; the fire either from malice or neglect had not been sufficiently kindled, so that his legs and thighs were first burnt, and one of his hands dropped off before he expired; yet the voice with which he called upon his Redeemer was not that of one impatient, or overcome with pain; he remained still and calm, we are told, to the last; and at length, in the words of Fox, 'died as quietly as a child in his bed.' No father in his household, no gardener in his garden, no husbandman in his vineyard, was ever more employed than Hooper had been in his diocese among his flock, going about the towns and villages teaching and preaching to the people there.

Saunders and Taylor, two other clergymen, whose zeal had been distinguished in carrying on the Reformation, were the next that suffered. And now Ridley bishop of London, and the venerable Latimer bishop of Worcester, were to receive the martyr's crown. Ridley was one of the ablest champions of the Reformation: his piety, learning, and solidity of judgment, were admired by his friends and dreaded by his enemies. The night before his execution he invited the mayor of Oxford and his wife to see him die; and when he saw them melted into tears he himself appeared quite unmoved. When he came to the stake where he was to be burnt, he found his old friend Latimer there before him, and began to comfort him in his sufferings, while Latimer was as ready to return the kind office. Ridley distributed such trifles as he had about him to those who were near him; and many pressed about him to obtain something as a relic. They then undressed for the stake; and Latimer, when he had put off his prison dress, remained in a shroud which he had put on, instead of a shirt, for that day's office. When the fire was brought Latimer said, 'Be of good comfort, master Ridley, and play the man! we shall this day light such a candle, by God's grace, in England, as I trust shall never be put out!' The venerable old man received the flame as if embracing it; and having, as it were, bathed his hands in the fire, and stroked his face with them, died apparently without pain. Ridley endured a long martyrdom, and fell at Latimer's feet. As the bodies were consumed the quantity of blood which gushed from Latimer's heart astonished the beholders.

As soon as Cranmer perceived what course events were likely to take, after king Edward's death, he gave orders that all his debts should be paid to the uttermost farthing, and cancelled the bills which were due to him from persons who were not in a condition to discharge them. This being done, he said he was his own man, and, with God's help, able to answer all the world



and all worldly adversities. Those adversities soon came upon him; he was attainted of treason, and adjudged guilty of it. Accordingly he was arraigned for blasphemy, incontinency, and heresy, before the same commissioners who condemned his fellow-prisoners: but he was dealt with very differently from any of the former sufferers; being removed to the house of the dean of Christ Church, and treated there rather as a guest than a prisoner. We have noticed the success of this treatment on a mind naturally timid. See our article CRANMER. He signed a recantation of his former opinions, and concluded it with a protestation that he had done it freely and only for the discharge of his conscience. The queen, however, was resolved to make him a sacrifice to her resentments. She said it was good for his own soul that he repented; but, since he had been the chief spreader of heresy over the nation, it was necessary to make him a public example; so the writ was sent down to burn him: and, after some stop had been made in the execution of it, new orders came for doing it suddenly. This seems to have been kept from Cranmer's knowledge. He, however, was gradually prepared by a better influence for the worst; and on being carried to St. Mary's where Dr. Cole vindicated the queen's justice in condemning Cranmer while he magnified his conversion and ascribed it to the workings of God's Spirit, the conduct of the archbishop far more surprised his enemies. A Romanist who was present, and who thought that his former life and wretched end deserved a greater misery, if greater had been possible, was yet, in spite of his opinions, touched with compassion at beholding him in a bare and ragged gown, exposed to universal contempt. 'I think,' said he 'that there was none that pitied not his case, and bewailed not his fortune, and feared not his own chance, to see so noble a prelate, so grave a counsellor, of so long continued honor, after so many dignities, in his old years to be deprived of his estate, adjudged to die, and in so painful a death to end his life.' In this hour of utter humiliation, and severe repentance, he certainly possessed his soul in patience; never had his mind been more clear and collected, never had his heart been so strong. At the stake no cry was heard from him, save the exclamation of the proto-martyr Stephen, 'Lord Jesus, receive my Spirit!' He stood immovable as the tree to which he was bound, his countenance raised, looking to heaven, and anticipating that rest into which he was about to enter.

Bonner now seemed not satisfied with single deaths, but sent men in whole companies to the flames; even women were not spared; and in Guernsey, when a woman condemned for heresy was delivered of a child in the midst of the flames, and some of the spectators humanely snatched it out, the magistrate, who was a papist, ordered it to be thrown in again, and it was consumed with the mother! During the four years that this persecution continued, it appears by authentic records that 280 persons were burnt alive; the number of those who perished in prison is unknown. The loss of property in London alone, consequent upon the arrest or flight of

substantial citizens, and the general insecurity, was estimated at £300,000. Nor was it in wealth alone that the kingdom suffered; the spirit of the nation sunk; and the character, and with it the prosperity, of the English would have been irrecoverably lost, if God in his mercy had not cut short this abominable tyranny. Mary was supposed to be with child; but those appearances, which had so far deceived the queen herself that the cradle was made ready, proved to be the indications of a mortal disease. Not a week before her death three women and two men were burnt at Canterbury.

Elizabeth, immediately on her accession, made greater approaches to toleration than any prince who had hitherto reigned on any throne in Europe. Indulgence and forbearance, such as that age had never seen, were freely extended to all; neither were there any violations of this unknown and unthought of generosity till repeated acts of treason endangered the safety both of her person and her throne. When the parliament met, the keeper of the great seal, Sir Nicholas Bacon, was directed, with a moderation at that time very unusual, to entreat the members to reunite all classes of the people by avoiding the extremes of both parties. In consequence of this advice, and in accordance with the known wishes of the queen, public worship was appointed in the vulgar tongue—the supremacy of the queen was restored—the acts of Edward, concerning religion, were renewed and confirmed. No laws were made to punish the Romanist persecutors of the former reign—no retaliation was attempted—no censure was passed—no disapprobation expressed.

The first act of the new queen was to take Sir William Cecil into her council, and appoint him her principal secretary. When the bill for restoring the supremacy to the crown was debated in parliament, it was opposed by the bishops. Heath said, that, as concerning temporal government, the house could give her highness no further authority than she already had by right and inheritance, not by their gift, but by the appointment of God, she being their sovereign lord and lady, their king and queen, their emperor and empress. But spiritual government they could not grant, neither could she receive.

The bishop of Chester, speaking upon the same subject, asked of whom those men, who in this and other points dissented from the Catholic church, learned their doctrine? 'They must needs answer, said he, 'that they learned it of the Germans. Of whom did the Germans learn it? Of Luther. Well, then, of whom did Luther learn it? He shall answer himself: he saith, that such things as he teacheth against the mass, and the blessed sacrament of the altar, he learned of Satan, the devil; at whose hands, it is like, he did also receive the rest of his doctrines.' The infamous persecutor, Story, went beyond this in the house of commons. He boasted of the part he had taken; related with exultation how he had thrown a faggot in the face of an earwig, as he called him, who was singing psalms at the stake, and how he had thrust a thorbush under his feet to prick him: wished that he had

done more; and said he only regretted that they should have labored at the 'young and little twigs, when they ought to have struck at the root;' words by which it was understood that he meant the queen. Even this unreasonable insolence did not provoke the government to depart from the temperate course which it had laid down. The measures adopted by the pope were, at this time, not less impolitic than cruel and wicked. It is possible that Elizabeth would have been content to have allowed the people to retain their faith so long as her crown was independent. The measures of the pope, and the dissensions he fomented, however, gradually kindled in Elizabeth's mind the most anxious apprehensions for her individual safety as well as that of her throne. The insurrection of Northumberland and Westmoreland was sanctioned by the pope, who, in his letters, exhorts them 'to persevere in the work, not doubting but that God would grant them assistance; and that if they should die in asserting the Catholic faith, and the authority of the see of Rome, it were better for them, with the advantage of a glorious death, to purchase eternal life, than by ignominiously living, with the loss of their souls, shamefully to obey the will of an ungovernable woman.'—Pii. V. Epist. p. 290. Soon after this pious exhortation the pope, in the thirteenth year of the reign of Elizabeth, fulminated the Bull of Excommunication 'out of the fulness of his apostolic power,' declaring the queen to be a heretic, and a favorer of heretics. 'We declare her,' said the pope, 'to be deprived of her pretended title to the kingdom aforesaid, and of all dominions, dignity, and privilege whatsoever: and also the nobility, subjects, and people of the said kingdoms, and all which have in any sort sworn unto her, to be for ever absolved from every such oath, and all manner of duty, of dominion, of allegiance, and obedience. We also command and interdict all and every the noblemen, subjects, and people, aforesaid, that they presume not to obey her, or her monitions, mandates, and laws, and those which shall do to the contrary we do likewise anathemise.' Irritated by this presumptuous and scandalous decree Elizabeth procured an act declaring it to be high treason to affirm that the queen was not a lawful sovereign, or to bring bulls, indulgences, or absolutions from the pope. Matters now threatened so complete a separation of England from Rome that the pope declared it would be of so much benefit to Christendom that Elizabeth should be destroyed, that he was ready to aid in person, to spend the whole revenue of the apostolic see, all the chalices and crosses of the church, and even his very clothes, to procure her destruction, &c. A public disputation was at this time appointed, not, as in Mary's reign, to be concluded by burning those who differed in opinion from the ruling party, but with full liberty of speech, and perfect safety for the Romish disputants. Upon Heath's motion, the queen ordered it should be managed in writing, as the best means to avoid vain altercation; but, when it came to the point, the Romanists, upon some difference concerning the manner of proceeding, refused to dispute at all. For this contempt of the privy council, in whose presence

they had met, they were fined. Without delay Elizabeth then deprived the refractory bishops, Kitchen of Llandaff being the only one who conformed: there were but fourteen living, many having died in the great mortality at the close of the preceding reign. The vacant sees were filled by Parker, Grindal, Cox, Sands, Jewel, Parkhurst, Pilkington, and others; men worthy to be held in lasting remembrance and honor, who had either escaped, during the Marian persecution, by retiring to the continent or secreting themselves at home. Thus was gradually established, never more, we trust, to be subverted, the separation of England and all the members of her hierarchy from the domination of Rome.

VIII. *The Reformation in Denmark, France, &c.*—In Denmark the Reformation was introduced as early as the year 1521, in consequence of the ardent desire of Christiern II. to have his subjects instructed in the doctrines of Luther. His uncle Frederick, duke of Holstein and Sleswick, being appointed his successor, conducted the Reformation with much greater prudence than his predecessor. He permitted the Protestant doctors to preach publicly the sentiments of Luther, but did not venture to change the established government and discipline of the church. However, he procured the publication of a famous edict, by which every subject of Denmark was declared free either to adhere to the tenets of the church of Rome, or to the doctrine of Luther; and the papal tyranny was totally destroyed by his successor Christiern III., who began by suppressing the despotic authority of the bishops, and restoring to their lawful owners a great part of the wealth and possessions which the church had acquired. This was followed by a plan of religious doctrine, worship, and discipline, laid down by Bugenhagen, whom the king had sent for from Wittemberg; and, in 1539, an assembly of the states at Odensee gave a solemn sanction to all these transactions, and settled that form of church government which has since been retained.

The first dawn of the Reformation in France appeared, as we have before noticed, in the preaching of Waldo, who, in the twelfth century, brought to light some truths which had been long hidden amidst the ignorance and superstition of the Romish church; and, though persecution soon attended his steps, it served but to scatter his principles, and disperse his followers over the face of Europe. Waldo himself appears to have proclaimed his opinions in various parts of the continent. The Albigenses, so called from the country about Toulouse, where they dwelt, embraced in a body the doctrine of reform. It was carried into Calabria, Bohemia, Germany, Flanders, Poland, Spain, and even the dominions of the grand sultan.

Calvin was born at Noyon, in Picardy, early in the sixteenth century; when twenty years of age, he first preached the doctrines of the Reformation to his countrymen; and, seven years afterwards (in 1536), printed his Institutes, which contain a full, and certainly a very able, statement of his opinions. This work was dedicated, in a preface written with remarkable elegance of style, to Francis I.; but it does not

seem to have produced much effect on the mind of that monarch. In 1553 Calvin edited an edition of Olivitan's translation of the Bible, which proved of great benefit to the church. In 1557, however, an attempt was made to establish an inquisition at Paris, after the plan of that in Spain, to put down heretical opinions; but it did no effectual mischief. The king of Navarre, who was also a prince of the blood, and through whom the title to the crown of France afterwards descended to his son Henry IV., became about this time a convert to the reformed doctrines. In 1562 the ever-memorable Charles IX. succeeded to his brother. As he was only nine years of age at that time, the government remained in the hands of Catherine. Two years after this period Calvin died. It does not appear that this great man, except at an early period of his life, took directly any personal part in prosecuting the Reformation in France; but it grew up under his inspection; and his authority was the acknowledged human standard of faith and duty. In 1571 the Protestant church in France had reached its highest point of prosperity. A synod was held at Rochelle, where the queen of Navarre, Jean D'Albert, her son, afterwards Henry IV., and two princes of the royal family, attended. At that time the protestants had 2150 churches, some of which contained 10,000 members. The deepest aversion, however, to the views of the Protestants had long dwelt in the minds of all connected with the court, except the few members of their own body; and a plot for getting rid of the reformed religion had long been meditated. To the queen-mother, one of the family of Guise, the atrocious contrivance is due, of the means by which it was to be attempted. On the occasion of the marriage of Henry, with the sister of Charles IX., the whole body of Protestants were enticed to Paris. After the admiral De Coligny, the champion of the reformed cause, as he was really the head of the party, was fairly in the toils, the minds of the populace were exasperated against the Protestants by the contrivance of the Duc de Guise; and, by the command of the king, they were all given up to slaughter. The proclamation for their destruction was made on the night of St. Bartholomew; and, at two o'clock in the morning, the work of death began. The king himself is said to have shot from a gallery many of the fugitives; and neither age, rank, nor character, afforded any protection to the unfortunate victims. Henry of Navarre, the brother-in-law of Charles, the prince De Conde his uncle, and the king's physician, were alone exempted from destruction. Henry and De Conde were hurried from their beds, and dragged, not without danger, before the king, who, when they refused to be converted, as the phrase ran, broke out into an excessive rage, declaring that he would be obeyed as the vicegerent of God; that they must teach others to submit by their acquiescence; and that it became them no longer to hold themselves in opposition to the holy mother. They were in consequence obliged to attend mass. The massacre was continued without cessation for three days, till the king became aghast at his own act, and his conscience

was so haunted with images of murder and death, that he directed it should cease. Charles IX. survived this event only one year; he lived, however, to repent of his crimes, and to suffer for them. His death was of that kind which it has pleased God often to inflict upon eminent persecutors of his church. He was tormented in mind and body; and sank into his untimely grave unhonored even by his former friends, and unregretted by every lover of his country. During the concluding period of this reign, the reformed church was at a very low ebb. There could be no security that the anniversary of St. Bartholomew would not be celebrated with a recurrence of the same disasters. The heads of the church were gone. Henry of Navarre himself seemed to have been in a sort of imprisonment, and the remainder of the scattered flock could scarcely be collected together. It was not till the year 1578 that another synod was held, and then no formal notice was taken of the late events. Henry III. succeeded his brother in 1574. During his reign the great conflict for independence and religious liberty was being carried on in the Low Countries; and the successful issue of it gave respect and consideration to the Protestant cause wherever its supporters were found.

At length, in 1589, Henry IV. ascended the throne. Never had a prince been nurtured amidst greater dangers, concerned in more critical enterprises, or come to a throne more encompassed with difficulties. He had been well educated by his excellent mother, whose prudence and power he inherited, but not her piety. In the year 1572 he married Margaret, sister of Charles IX., from whom he was divorced. He married a second time Mary of Medicis. This was the first step by which he allied himself to the Catholics; and it was doubted by some whether to it may not be traced another great error of his life, his abjuration of the Protestant faith, which took place in the year 1592. In the year 1598 he granted all his subjects full liberty of conscience by the famous edict of Nantes, and the Reformation seemed to be established throughout his dominions. During the minority of Louis XIV., however, this edict was revoked by cardinal Mazarine; since which time the Protestants have often been cruelly persecuted; nor has the profession of the reformed religion in France been at any time so safe as in most other countries of Europe.

In the other parts of the continent the cause of the Reformation made a considerable, though secret, progress. Some countries threw off the Romish yoke entirely; and in others a prodigious number of families embraced the principles of the reformed religion. It is certain indeed, and some Roman Catholics themselves do not hesitate to acknowledge it, that the papal doctrines and authority would have fallen into ruin in all parts of the world at once, had not the force of the secular arm been employed to support the tottering edifice. In several places the pope put a stop to the progress of the Reformation, by letting loose the inquisitors; who spread dreadful marks of their barbarity through the greatest parts of Europe. These formidable ministers of

superstition put so many to death, and perpetrated such horrid acts of cruelty and oppression, that most of the reformed consulted their safety by a voluntary exile; while others returned to the religion of Rome, at least in external appearance. The political results of the Reformation are thus summarily stated by Villiers:— 'Europe, plunged for several centuries in a stupor and apathy interrupted only by wars, or rather by incursions and robberies, without any beneficial object to humanity, received at once a new life and a new activity; a universal and deep interest agitated the nations, their powers were developed, their minds expanded by new political ideas. Former revolutions had only exercised men's arms; this employed their heads. The people, who before had been only estimated as flocks passively subject to the caprice of their leaders, now began to act for themselves, and to feel their importance and ability. Those who embraced the reform made common cause with their princes for liberty; and hence arose a closer bond, a community of interests and of action, between the sovereign and his subjects. Both were for ever delivered from the excessive and burdensome power of the clergy, as well as from the struggle, so distressing to all Europe, between the popes and the emperors, for supreme power. Social order was now regulated and brought nearer to perfection. In one part of Europe the church ceased to form an extraneous state within the state; from which it was easy to foretell that this change would one day be effected through the whole of it, and that its head would be reduced to the simple spiritual primacy. At length the Catholic clergy reformed

their conduct on the example of the Protestants, and gained in manners, knowledge, and esteem, as much as they lost in power and riches. Nor has science been less a gainer. It is little more than two centuries since Galileo, having discovered and collected incontestable proofs of the true motion of the earth, was condemned, as a heretic, to perpetual imprisonment, by the tribunal of the inquisition. The ancient system of Roman Catholicism was diametrically opposite to the progress of knowledge; the Reformation, which has contributed to free the human mind from such an adversary, must ever be considered as one of the most fortunate epochs in the intellectual culture of modern nations. The opposite system of liberality, of examination, of free criticism, established by the Reformation, has become the ægis under which the Galileos of subsequent ages have been enabled securely to develop their exalted conceptions.'

The moral effects of the Reformation on the opinions and conduct of mankind must not be overlooked. The intention of the Reformers was, in principle, to free themselves from the despotism and infallibility of the popes; to depend only on the Sacred Writings for the grounds of their belief; and, in short, to overthrow the scholastic divinity, which was become the soul of the Roman theology, and the firm support of the hierarchy. Hence it follows that the Reformation, in its essence, must have had an immediate and powerful influence on the liberty of men's opinions, judgment, and actions. It at once stimulated them to think for themselves, and handed to them a perfect standard of faith and morals.

**REFRACT**, *v. a.* } Lat. *refractus*; Fr. *re-*  
**REFRACTION**, *n. s.* } *fraction*. To break the  
**REFRACTIVE**, *adj.* } natural course of rays:  
the noun substantive and adjective corresponding.

*Refraction*, in general, is the incurvation or change of determination in the body moved, which happens to it whilst it enters or penetrates any medium: in dioptricks, it is the variation of a ray of light from that right line, which it would have passed on in, had not the density of the medium turned it aside.

*Harris.*

The image of the sun should be drawn out into an oblong form, either by a dilatation of every ray, or by any other casual inequality of the *refractions*.

*Newton.*

Those superficies of transparent bodies reflect the greatest quantity of light, which have the greatest *refracting* power; that is, which intercede mediums that differ most in their *refractive* densities.

*Id. Optics.*

If its angle of incidence be large, and the *refractive* power of the medium not very strong to throw it far from the perpendicular, it will be *refracted*.

*Cassini's Philosophical Principles.*

Rays of light are urged by the *refracting* media.

*Cheyne.*

*Refracted* from yon eastern cloud,

The grand æthereal bow shoots up. *Thomson.*

**REFRACTION** is chiefly used with regard to the rays of light, and is an inflection or deviation of the rays from their rectilinear course on passing

obliquely out of one medium into another of a different density.

That a body may be refracted, it is necessary that it should fall obliquely on the second medium: in perpendicular incidence there is no refraction. Yet Vossius and Snellius imagined they had observed a perpendicular ray of light undergo a refraction; a perpendicular object appearing in the water nearer than it really was: but this was attributing that to a refraction of the perpendicular rays, which was owing to the divergency of the oblique rays after refraction, from a nearer point. Yet there is a manifest refraction even of perpendicular rays found in island crystal. Rohault adds, that though an oblique incidence be necessary in all other mediums we know of, yet the obliquity must not exceed a certain degree; if it do, the body will not penetrate the medium, but will be reflected instead of being refracted. Thus, cannon-balls, in sea engagements, falling very obliquely on the surface of the water, are observed to bound or rise from it, and to sweep the men from off the enemy's decks. And the same thing happens to the little stones with which children make their ducks and drakes along the surface of water.

The ancients confounded refraction with reflection; and it was Newton who first taught the true difference between them. He shows however that there is a good deal of analogy

between them, and particularly in the case of light.

The laws of the refraction of the rays of light in mediums differently terminated, i. e. whose surfaces are plane, concave, and convex, make the subject of dioptrics. By refraction it is that convex glasses, or lenses, collect the rays, magnify objects, burn, &c., and hence the foundation of microscopes, telescopes, &c. And by refraction it is that all remote objects are seen out of their real places; particularly that the heavenly bodies are apparently higher than they are in reality. The refraction of the air has many times so uncertain an influence on the places of celestial objects near the horizon, that, wherever refraction is concerned, the conclusions deduced from observations that are much affected by it will always remain doubtful, and sometimes too precarious to be relied on. See OPTICS.

The true law of refraction, viz. that the ratio of the sines of the angles made by the perpendicular (to the plane bounding the mediums) with the incident and refracted rays, is a constant and fixed ratio, was first discovered by Willebrord Snell, professor of mathematics, at Leyden. From this law it follows that one angle of inclination, and its corresponding refracted angle, being found by observation, the refracted angles corresponding to the several other angles of inclination are thence easily computed. Now Zahnus and Kircher have found that, if the angle of inclination be  $70^\circ$ , the refracted angle out of air into glass will be  $38^\circ 50'$ ; on which principle Zahnus has constructed a table of these refractions for the several degrees of the angle of inclination; a specimen of which here follows:—

Angle of Inclination.	Refracted angle.			Angle of Refraction.		
°	°	'	"	°	'	"
1	0	40	5	0	19	55
2	1	20	6	0	39	54
3	2	0	4	0	59	56
4	2	40	5	1	19	55
5	3	20	3	1	39	57
10	6	39	16	3	20	44
20	13	11	35	6	48	25
30	19	29	29	10	30	31
45	28	9	19	16	50	41
90	41	51	40	48	8	20

Hence it appears that, if the angle of inclination be less than  $20^\circ$ , the angle of refraction out of air into glass is almost one-third of the angle of inclination; and therefore a ray is refracted to the axis of refraction by almost a third part of the quantity of its angle of inclination. And on this principle it is that Kepler, and most other dioptrical writers, demonstrate the refractions in glasses; though, in estimating the law of these refractions, he followed the example of Alhazen and Vitello, and sought to discover it in the proportion of the angles, and not in that of the sines, or cosecants, as discovered by Snell, as mentioned above.

REFRACTION OF ALTITUDE is the arc or portion of a vertical circle, by which the altitude of a star is increased by the refraction of light.

REFRACTION OF ASCENSION AND DESCENSION is an arc of the equator, by which the ascension and descension of a star, whether right or oblique, is increased or diminished by the refraction.

REFRACTION OF DECLINATION is an arc of a circle of declination, by which the declination of a star is increased or diminished by the refraction.

REFRACTION OF LATITUDE is an arc of a circle of latitude, by which the latitude of a star is increased or diminished by the refraction.

REFRACTION OF LONGITUDE is an arc of the ecliptic, by which the longitude of a star is increased or diminished by the refraction.

REFRACTION, TERRESTRIAL OF ATMOSPHERICAL, is that by which terrestrial objects appear to be raised higher than they really are, in observing their altitudes. The quantity of this refraction is estimated by Dr. Maskelyne at one-tenth; by Le Gendre at one-fourteenth; by De Lambre at one-eleventh, and by others at the twelfth of the distance of the object observed, expressed in degrees of a great circle. But there can be no fixed quantity of this refraction, as it depends on the state of the atmosphere, which is very variable. Some very singular effects of this are related in the Philosophical Transactions for 1798, by W. Latham, esq., F. R. S. and A. S.

Many curious effects of atmospherical refraction have been noticed by ingenious men; for which see Dr. Hutton's Dictionary, and the papers of Vince, Huddart, Latham, &c., in the Philosophical Transactions. For more on the theory of atmospherical refraction, the reader may consult the treatises on astronomy by Vince, Gregory, Biot, Woodhouse, and Prony's Architectural Hydraulic. See also our article ASTRONOMY.

REFRACTORY, *adj.* } French *refractaire*;  
 REFRACTORINESS, *n. s.* } Lat. *refractorius*. It is sometimes accented on the first syllable, but by Shakspeare on the second; sullen; obstinate; perverse: sullenness; obstinacy.

There is a law in each well-ordered nation,  
 To curb those raging appetites that are  
 Most disobedient and refractory. *Shakspeare.*

A rough hewn seaman, being brought before a wise justice for some misdemeanor, was by him ordered to be sent away to prison, and was refractory after he heard his doom, insomuch as he would not stir a foot from the place where he stood; saying, it was better to stand where he was, than go to a worse place. *Bacon's Aphorisms.*

I did never allow any man's refractoriness against the privileges and orders of the houses. *King Charles.*

It maketh them indocile and intractable, averse from better instruction, pertinacious in their opinions, and refractory in their ways. *Barrow.*

Great complaint was made by the presbyterian gang, of refractoriness to obey the parliament's order. *Saunderson.*

Refractory mortal! if thou wilt not trust thy friends, take what follows; know assuredly, before next full moon, that thou wilt be hung up in chains. *Arbuthnot's History of John Bull.*

These atoms of theirs may have it in them, but they are refractory and sullen; and therefore, like men of the same tempers, must be hanged and buried into reason. *Bentley.*

**REFRAIN'**, *v. a.* & *v. n.* Fr. *refrener*; Lat. *re* and *fratum*. To hold back; to keep from action: to forbear; to abstain.

Hold not thy tongue, O God, keep not still silence; *refrain* not thyself. *Psalm lxxxiii. 1.*

My son, walk not thou in the way with them, *refrain* thy foot from their path. *Proverbs i. 15.*

For my name's sake will I defer mine anger, and *refrain* for thee, that I cut thee not off. *Isaiah.*

In what place, or upon what consideration soever it be, they do it, were it in their own opinion of no force being done, they would undoubtedly *refrain* to do it. *Hooker.*

Nor from the holy one of heaven *Refrained* his tongue. *Milton.*

That they fed not on flesh, at least the faithful party before the flood, may become more probable, because they *refrained* therefrom some time after. *Browne's Vulgar Errors.*

Neptune atoned, his wrath shall now *refrain*,  
Or thwart the synod of the gods in vain. *Pope.*

**REFRAN'GIBLE**, *adj.* } Lat. *re* and *fram-*  
**REFRANGIBIL'ITY**, *n. s.* } *go.* Capable of, or  
tending to, refraction: the noun substantive cor-  
responding.

As some rays are more *refrangible* than others, that is, are more turned out of their course, in passing from one medium to another; it follows that, after such refraction, they will be separated, and their distinct colour observed. *Locke.*

*Refrangibility* of the rays of light is their disposition to be refracted or turned out of their way, in passing out of one transparent body or medium into another. *Newton.*

**REFRANGIBILITY OF LIGHT** is chiefly applied to the disposition of rays to produce different colors. See **OPTICS**.

**REFRESH**, *v. a.* } Fr. *refraischer*, *refres-*  
**REFRESH'ER**, *n. s.* } *cher*; Lat. *refrigero*. To  
**REFRESH'MENT**. } revive; recreate; relieve;  
improve; refrigerate: a refresher is that which  
refreshes: refreshment, relief, or that which gives relief.

A dew coming after heat *refresheth*. *Ecc. xliii. 22.*  
Service shall with steel sinews toil;  
And labour shall *refresh* itself with hope. *Shakspeare.*

The rest *refresh* the scaly snakes, that fold  
The shield of Pallas, and renew their gold. *Dryden.*

If you would have trees to thrive, take care that no plants be near them, which may deprive them of nourishment, or hinder *refreshings* and helps that they might receive. *Mortimer.*

Such honest *refreshments* and comforts of life, our christian liberty has made it lawful for us to use. *Sprat.*

His meals are coarse and short, his employment warrantable, his sleep certain and *refreshing*, neither interrupted with the lashes of a guilty mind, nor the aches of a crazy body. *South.*

He was full of agony and horror upon the approach of a dismal death, and so had most need of the *refreshments* of society, and the friendly assistance of his disciples. *South.*

The kind *refresher* of the summer heats. *Thomson.*

**REFRIG'ERATE**, *v. a.* } Lat. *refrigero*.  
**REFRIG'ERANT**, *adj.* } To cool; refrige-  
**REFRIGERA'TION**, *n. s.* } rant and refrige-  
**REFRIG'ERATIVE**, *adj.* } rative, as well as  
**REFRIG'ERATORY**, *adj.* & *n. s.* } refrigeratory, ad-  
**REFRIG'ERIUM**, *n. s.* } jective, mean

cooling, or having the power to cool: refrigeration, the act of cooling, or state of being cooled: refrigeratory, noun substantive, the part of old distilling vessels that was placed about the head of a still, and filled with water to cool the condensing vapors; any thing internally cooling: refrigerium, cool refreshment; refrigeration.

In the cure of gangrenes, you must beware of dry heat, and resort to things that are *refrigerant*, with an inward warmth and virtue of cherishing. *Bacon.*

The great breezes, which the motion of the air in great circles, such as the girdle of the world produceth, do *refrigerate*; and therefore in those parts noon is nothing so hot, when the breezes are great, as about ten of the clock in the forenoon. *Id.*

Divers do stut; the cause may be the *refrigeration* of the tongue, whereby it is less apt to move. *Id.*

If the mere *refrigeration* of the air would fit it for breathing, this might be somewhat helped with bellows. *Wilkins.*

Whether they be *refrigerated* inclinatoryly or somewhat equinoxially, though in a lesser degree, they discover some veracity. *Browne.*

A delicate wine, and a durable *refrigeratory*. *Mortimer.*

It must be acknowledged, the ancients have talked much of annual *refrigeriums*, respites or intervals of punishment to the damned; as particularly on the festivals. *South.*

If it arise from an external cause, apply *refrigerants*, without any preceding evacuation. *Wiseman.*

**REFT**, *part. pret.* of REAVE, which see. Deprived; taken away. Obsolete.

Thus we well left, he better *reft*,  
In heaven to take his place,  
That like by life and death, at last,  
We may obtain like grace. *Ascham's Schoolmaster.*

About his shoulders broad he threw  
An hairy hide of some wild beast, whom he  
In savage forest by adventures slew,  
And *reft* the spoil his ornament to be. *Spenser.*  
Another ship had seized on us,  
And would have *reft* the fishers of their prey. *Shakspeare.*

Our dying hero from the continent  
Ravished whole towns, and forts from Spaniards *reft*,  
As his last legacy to Britain left. *Waller.*

**REF'UGE**, *n. s.* & *v. a.* French *refuge*; Ital. Port. and Span. *refugio*; Lat. *refugium*. Shelter or protection from danger or distress; expedient: to shelter: a refugee is one who seeks a refuge.

They shall be your *refuge* from the avenger of blood. *Joshua.*

The Lord will be a *refuge* for the oppressed, a *refuge* in times of trouble. *Psalm ix. 9.*

This last old man,  
Whom with a cracked heart I have sent to Rome,  
Loved me above the measure of a father:  
Their latest *refuge* was to send him. *Shakspeare.*

Silly beggars,  
Who, sitting in the stocks, *refuge* their shame  
That many have, and others must, sit there. *Id.*  
Light must be supplied, among graceful *refuges*  
by terracing any story in danger of darkness. *Wotton.*

Rocks, dens, and caves, but I in none of these  
Find place or *refuge*. *Milton's Paradise Lost.*

The young vipers supposed to break through the belly of the dam, will, upon any fright, for protection run into it; for then the old one receives them in at her mouth, which way, the fright being past, they

will return again ; which is a peculiar way of *refuge*.  
*Bruins.*

Poor *refugees*, at first they purchase here ;  
And, soon as denized, they domineer. *Dryden.*

Dreads the vengeance of her injured lord ;  
Even by those gods, who *refuged* her, abhorred. *Id.*

This is become more necessary in some of their  
governments, since so many *refugees* settled among  
them. *Addison.*

Those, who take *refuge* in a multitude, have an  
Arian council to answer for. *Atterbury.*

REFUGE, CITIES OF, were places provided as  
asyla, for such as against their will should happen  
to kill a man. Of these cities there were three  
on each side Jordan ; on this side were Kedesh  
of Nephtali, Hebron, and Schechem ; beyond  
Jordan were Bezer, Golan, and Ramoth-Gilead.  
When any of the Hebrews, or strangers that  
dwelt in their country, happened accidentally to  
kill a man, they might retire thither, to be out of  
the reach of the relations of the deceased, and to  
prepare for their defence and justification before  
the judges. The manslayer underwent two trials :  
first before the judges of the city of refuge to  
which he had fled ; and secondly before the  
judges of his own city. If found guilty, he was  
put to death. If acquitted, he was not immedi-  
ately set at liberty ; but, to inspire a degree of  
horror against even involuntary homicide, he was  
reconducted to the place of refuge, and obliged  
to continue there in a sort of banishment till the  
death of the high priest. If, before this time, he  
ventured out, the avenger of blood might freely  
kill him ; but after the high priest's death he was  
at liberty to go where he pleased without molest-  
ation. The cities of refuge were to be well sup-  
plied with water and necessary provisions ; to be  
of easy access ; to have good roads leading to  
them, with commodious bridges where there was  
occasion. The width of the roads was to be  
thirty-two cubits or forty-eight feet at least. At  
all cross roads direction posts were erected, with  
an inscription pointing out the road to the cities  
of refuge. The 15th of Adar, which answers to  
our February, was appointed for the city magis-  
trates to see that the roads were in good condi-  
tion. No persons in any of these cities were  
allowed to make weapons, lest the relations of  
the deceased should be furnished with the means  
of gratifying their revenge.

REFULGENT, *adj.* } Latin *refulgens*.

REFULGENTLY, *adv.* } Bright ; shining ; glit-  
tering : the adverb corresponding.

He neither might, nor wished to know

A more *refulgent* light. *Waller.*

So conspicuous and *refulgent* a truth is that of  
God's being the author of man's felicity, that the  
dispute is not so much concerning the thing, as con-  
cerning the manner of it. *Boyle.*

Agamemnon's train,

When his *refulgent* arms flashed through the shady  
plain,

Fled from his well-known face. *Dryden's Æneis.*

REFUND', *v. a.* Lat. *refundo*. To pour or  
give back ; repay ; restore.

A governor that had pillaged the people, was, for  
receiving of bribes, sentenced to *refund* what he had  
wrongfully taken. *L'Entrange.*

Were the humours of the eye tinged with any  
colour, they would *refund* that colour upon the ob-

ject, and so it would not be represented as in itself  
it is. *Ray.*

Such wise men as himself account all that is past  
to be also gone ; and know that there can be no  
gain in *refunding*, nor any profit in paying debts.

*South.*

How to Icarus, in the bridal hour,

Shall I, by waste undone, *refund* the dowry ?

*Pope.*

REFUSE', *v. a., adj., &* } Fr. *refuser* ; Ital.  
REFU'SAL, *n. s.* } [*n. s.*] *recusare* ; Lat. *recu-*  
REFU'SER. } *so*. To deny that

which is requested or demanded ; reject ; not to  
accept or comply : the adjective, which as well  
as the noun substantive has its accent on the  
first syllable, means refused ; left when the rest is  
taken : the noun substantive, something so left :  
refusal is, the act of refusing ; denial ; preemp-  
tion ; option : refuser, he who refuses.

Every thing vile and *refuse* they destroyed. *Samuel.*

We dare not disgrace our worldly superiors with  
offering unto them such *refuse*, as we bring unto  
God himself. *Hooker.*

If he should offer to chuse, and chuse the right  
casket, you should *refuse* to perform your father's  
will, if you should *refuse* to accept him.

*Shakspeare.*

Many kinds have much *refuse*, which countervails  
that which they have excellent. *Bacon.*

Having most affectionately set life and death be-  
fore them, and conjured them to chuse one, and  
avoid the other, he still leaves unto them, as to  
free and rational agents, a liberty to *refuse* all his  
calls, to let his talents lye by them unprofitable.

*Hammond.*

Some few others are the only *refusers* and con-  
demners of this catholick practice. *Taylor.*

Wonder not then what God saw for you good

If I *refuse* not, but convert, as you,

To proper substance. *Milton.*

He never had vexatious law-disputes about his  
dues, but had his tithes fully paid, and not of the  
most *refuse* parts, but generally the very best. *Fell.*

Down with the falling stream the *refuse* run,

To raise with joyful news his drooping son.

*Dryden.*

Common experience has justly a mighty influence  
on the minds of men, to make them give or *refuse*  
credit to any thing proposed. *Loche.*

Please to bestow on him the *refuse* letters ; he  
hopes by printing them to get a plentiful provision.

*Spectator.*

This humourist keeps more than he wants, and  
gives a vast *refuse* of his superfluities to purchase  
heaven. *Addison.*

I know not whether it be more shame or wonder,  
to see that men can so put off ingenuity, as to de-  
scend to so base a vice ; yet we daily see it done,  
and that not only by the scum and *refuse* of the  
people. *Government of the Tongue.*

Women are made as they themselves would  
choose ;

Too proud to ask, too humble to *refuse*. *Garth.*

God has borne with all his weak and obstinate *re-*  
*fusals* of grace, and has given him time day after day.

*Rogers.*

When employments go a begging for want of  
hands, they shall be sure to have the *refusal*. *Swift.*

REFUTE', *v. a.* } Fr. *refuter* ; Span. and  
REFUTATION, *n. s.* } Port. *refutar* ; Lat. *refuto*.

To prove false or erroneous : the noun substantive  
corresponding.

**Self-des ruccion sought, refuses**

That excellence thought in thee. *Milton.*

He knew that there were so many witnesses in these two miracles, that it was impossible to *refute* such multitudes. *Addison.*

'Tis such miserable absurd stuff, that we will not honour it with especial *refutation*. *Bentley.*

**REGAIN'**, *v. a.* Fr. *regagnar*; re and gain. To recover; gain anew.

Hopeful to *regain*

Thy love, from thee I will not hide  
What thoughts in my unquiet breast are risen. *Milton.*

We've driven back

These heathen Saxons, and *regained* our earth,  
As earth recovers from an ebbing tide. *Dryden.*

As soon as the mind *regains* the power to stop or continue any of these motions of the body or thoughts, we then consider the man as a free agent. *Locke.*

**REGAL**, *adj. & n. s.* } Fr. Span. and Ital.

**REGALITY**, *n. s.* } *regal*; Latin *regalis*.

Royal; kingly: a kind of organ: regality is the noun substantive corresponding with regal as an adjective.

Behold the image of mortality,  
nd feeble nature clothed with fleshy 'tire,

When raging passion with fierce tyranny  
Robs reason of her due *regality*. *Spenser.*

Edward, duke of York,

Usurps the *regal* title and the seat  
Of England's true anointed lawful heir. *Shakespeare.*

The sounds that produce tones are ever from such bodies as are in their parts and parts equal; and such are in the nightingale pipes of *regals* or organs. *Bacon.*

He neither could nor would yield to any diminution of the crown of France, in territory or *regality*. *Id.*

The majesty of England might hang like Mahomet's tomb by a magnetick charm, between the privileges of the two houses, in airy imagination of *regality*. *King Charles.*

With them comes a third of *regal* port,  
With faded splendour wan, who by his gait  
And fierce demeanour seems the prince of hell. *Milton.*

When was there ever a better prince on the throne than the present queen? I do not talk of her government, her love of the people, or qualities that are purely *regal*; but her piety, charity, temperance, and conjugal love. *Swift.*

**REGALE'**, *v. a.* } Fr. *regaler*; Ital. *re-*

**REGALEMENT**, *n. s.* } *galare*. To refresh; entertain; the entertainment given.

I with warming puff *regaled* chilled fingers. *Philips.*

The muses still require  
Humid *reglement*, nor will aught avail  
Imploing Phœbus with unmoistened lips. *Id.*

**REGALIA** is also used for the apparatus of a coronation; as the crown, the sceptre with the cross, that with the dove, St. Edward's staff, the globe, and the orb with the cross, &c. See **CORONATION**.

**REGARD'**, *v. a. & n. s.* } Fr. *regarder*; Ital.

**REGARD'ABLE**, *adj.* } *riguardo*. To es-

**REGARD'ER**, *n. s.* } teem; value; no-

**REGARD'FUL**, *adj.* } tice; attend to;

**REGARD'FULLY**, *adv.* } observe: observe

**REGARD'LESS**, *adj.* } religiously; as a

**REGARD'LESSLY**, *adv.* } noun substantive,

**REGARD'LESSNESS**, *n. s.* } attention; respect;

account; relation; look; aspect: *regardable* is, observable; worthy of notice: *regarder*, he who pays attention or regard: *regardful*, observant; attention: the adverb corresponding: *regardless*, heedless; negligent; devoid of attention or care: the adverb and noun substantive corresponding.

He that observeth the wind shall never sow, and he that *regardeth* the clouds shall never reap.

*Proverbs.*

To him they had *regard*, because long he had bewitched them. *Acts* viii. 11.

He that *regardeth* the day, *regardeth* it unto the Lord; and he that *regardeth* not the day, to the Lord he doth not *regard* it. *Romans* xiv. 6.

It is peninsula, which *regardeth* the mainland. *Sandys.*

Mac Ferlagh was a man of meanest *regard* amongst them, neither having wealth nor power. *Spenser.*

He likeliest is to fall into mischance, *Id.*

That is *regardless* of his governance. *Id.*  
Change was thought necessary, in *regard* of the great hurt which the church did receive by a number of things then in use. *Hooker.*

This aspect of mine,

The best *regarded* virgins of our clime  
Have loved. *Shakespeare. Merchant of Venice.*

If much you note him,

You offend him; feed, and *regard* him not. *Shakespeare.*

Throw out our eyes for brave Othello,  
Even till we make the main and the aerial blue  
An indistinct *regard*. *Id. Othello.*

Is this the Athenian minion, whom the world  
Voiced so *regardfully*? *Id. Timon of Athens.*

Bryan was so *regardful* of his charge, as he never disposed any matter, but first he acquainted the general. *Hayward.*

Tintoger, more famous for his antiquity than *regardable* for his present estate, abutteth on the sea. *Carew.*

He denies

To know their God, or message to *regard*. *Milton.*  
How best we may

Compose our present evils, with *regard*  
Of what we are and where. *Id.*

*Regardless* of the bliss wherein he sat,  
Second to thee, offered himself to die  
For man's offence. *Id. Paradise Lost.*

I cannot discover this difference of the badger's legs, although the *regardable* side be defined, and the brevity by most imputed unto the left. *Brown.*

He, surprised with humble joy, surveyed  
One sweet *regard*, shot by the royal maid. *Dryden.*

Let a man be very tender and *regardful* of every pious motion made by the spirit of God to his heart. *South.*

The nature of the sentence he is to pronounce, the rule of judgment by which he will proceed, requires that a particular *regard* be had to our observation of this precept. *Atterbury.*

Their business is to address all the ranks of mankind, and persuade them to pursue and persevere in virtue, with *regard* to themselves; in justice and goodness with *regard* to their neighbours; and piety towards God. *Watts.*

We must learn to be deaf and *regardless* of other things, besides the present subject of our meditation. *Id.*

**REGARDANT**, in heraldry, signifies looking behind, and is applied to beasts represented on coats of arms, as in the annexed figure.





**REGARDER**, an ancient officer of the king's forest, sworn to make the regard of the forest every year; that is, to take a view of its limits, to enquire into all offences and defaults committed by the foresters within the forest, and to observe whether all the officers executed their respective duties.

**REGATA**, or **REGATTA**, a kind of boat race, formerly annually held at Venice, when that city was the capital of an independent republic. The race was performed in gondolas by gondoliers. The competitors were chosen from the families of the first rank; and no competitors at the ancient Olympic Games were ever more anxious for success. The course was about four miles. The gondolas, after starting, passed through the great winding canal, which divides the city into two parts, turned round a picket, and returning the same way, seized the prize, which was fixed at the acutest angle of the great canal, where it was visible by the spectators on both sides. On such occasions both the gondolas and the gondoliers were decorated in the most elegant and superb manner. Regattas, in imitation of the Venetian, have been often given on the Thames, and are still continued.

**REGEN**, a river in the interior of Germany, which rises on the southern frontier of Bohemia, unites with the Little Regen, and falls into the Danube, near Ratisbon.

**REGEN, CIRCLE OF THE**, is a province of Bavaria, adjacent to Bohemia, having the circle of the Upper Maine on the north-west, and that of the Lower Danube on the south-west. It has an area of 3800 square miles. This province is hilly and woody, including part of the districts called the Fichtelberg and Bohemian forest; yet it has several plains of considerable extent. The sale of timber and working in wood are considerable occupations. The fields also abound in game, and have mines of iron. Ratisbon, in the south of the circle, is the seat of the provincial administration; and Amberg, in the north, that of the high court of justice. Inhabitants, of whom the great majority are Catholics, 358,000.

**REGENERATE**, *v. a. & adj.* } Lat. *rege-*  
**REGENERATION**, *n. s.* } *neros*. Re and  
generate. To reproduce; beget or create anew: as an adjective reproduced; born anew to the Christian life: regeneration corresponding.

He saved us by the washing of *regeneration*, and renewing of the Holy Ghost. *Titus* iii. 5.

Thou! the earthly author of my blood,  
Whose youthful spirit, in me *regenerate*,  
Doth with a twofold vigour lift me up,  
To reach at victory. *Shakespeare. Richard II.*  
Albeit the son of this earl of Desmond, who lost his head, were restored to the earldom; yet could not the king's grace *regenerate* obedience in that degenerate house, but it grew rather more wild.

*Davies.*  
For from the mercy seat above,  
Prevenient grace descending, had removed  
The stony from their hearts, and made new flesh  
*Regenerate* grow instead. *Milton.*  
No sooner was a convert initiated, but by an easy figure he became a new man, and both acted and looked upon himself as one *regenerated* and born a second time into another state of existence. *Addison.*

Through all the soil a genial ferment spreads,  
*Regenerates* the plants, and new adorns the meads. *Blackmore.*

An alkali, poured to that which is mixed with an acid, raiseth an effervescence, at the cessation of which, the salts, of which the acid is composed, will be *regenerated*. *Arbutnot.*

If you fulfil this resolution, though you fall sometimes by infirmity; nay, though you should fall into some greater act, even of deliberate sin, which you presently retract by confession and amendment, you are nevertheless in a *regenerate* estate, you live the life of a Christian here, and shall inherit the reward that is promised to such in a glorious immortality hereafter. *Wake.*

**REGENT**, *adj. & n. s.* } Fr. *regent*; Lat. *re-*  
**REGENCY**, *n. s.* } *gens*. Governing; rul-  
**REGENTSHIP**. } ing; governor or ruler: one exercising vicarious royalty: regency and regentship, his office or station.

As Christ took manhood, that by it he might be capable of death, whereunto he humbled himself: so because manhood is the proper subject of compassion and feeling pity, which maketh the sceptre of Christ's *regency* even in the kingdom of heaven amiable. *Hooker.*

Lord *regent*, I do greet your excellence  
With letters of commission from the king. *Shakespeare.*

If York have ill demeaned himself in France,  
Then let him be denied the *regentship*. *Id.*

Regions they passed, the mighty *regencies*  
Of seraphim. *Milton.*

He together calls the *regent* powers  
Under him *regent*. *Id. Paradise Lost.*

The operations of human life flow not from the corporeal molds, but from some other active *regent* principle that resides in the body, or governs it, which we call the soul. *Hale.*

This great minister, finding the *regency* shaken by the faction of so many great ones within, and awed by the terror of the Spanish greatness without, durst begin a war. *Temple.*

But let a heifer with gilt horns be led  
To Juno, *regent* of the marriage bed. *Dryden.*

Men have knowledge and strength to fit them for action: women affection, for their better compliance: and herewith beauty to compensate their subjection, by giving them an equivalent *regency* over men. *Grew.*

**REGENT**, one who governs a kingdom during the minority or absence of the king. In England the methods of appointing this guardian or *regent* have been so various, and the duration of his power so uncertain, that from hence it might almost be collected that his office is unknown to the common law; and therefore, according to Sir Edward Coke, the surest way is to have him appointed by authority of the great council in parliament. The earl of Pembroke, by his own authority, assumed the regency of Henry III., who was then only nine years old, but was declared of full age by the pope at seventeen, confirmed the great charter at eighteen, and took upon him the administration of the government at twenty. A guardian and councils of regency were named for Edward III. by the parliament which deposed his father; the young king being then fifteen, and not assuming the government till three years after. When Richard II. succeeded, at the age of eleven, the duke of Lan-

caster took upon him the management of the kingdom till the parliament met, which appointed a nominal council to assist him. Henry V. on his death bed named a regent and a guardian for his infant son Henry VI., then nine months old: but the parliament altered his disposition, and appointed a protector and council, with a special limited authority. Both these princes remained in a state of pupilage till the age of twenty-three. Edward V., at the age of thirteen, was recommended by his father to the care of the duke of Gloucester; who was declared protector by the privy council. The statutes 25 H. VIII. c. 12, and 28 H. VIII. c. 7, provided that the successor, if a male and under eighteen, or if a female and under sixteen, should be till such age in the governance of his or her natural mother (if approved by the king), and such other counsellors as his majesty should by will or otherwise appoint: and he accordingly appointed his sixteen executors to have the government of his son Edward VI., and the kingdom, which executors elected the earl of Hartford protector. And during the illness of George III. in the end of 1788, there were repeated debates in parliament, respecting a regency, the mode of settling it, and the most proper persons to fill it; but his majesty's recovery rendered it totally unnecessary. These debates were renewed in the end of 1810, and a limited regency for a year was committed to the prince of Wales, who, in consequence of the continued indisposition of his royal father, became regent with full power on the 18th of February 1812, till his father's death in 1820.

**REGENT** also signifies a professor of arts and sciences in a college, having pupils under his care; but it is generally restrained to the lower classes, as to rhetoric, logic, &c.: those of philosophy being called professors. In the English universities it is applied to masters of arts under five years standing, and to doctors under two.

**REGGERMINATION**, *n. s.* Re and germination. The act of sprouting again.

**REGGIO**, Regium Julii, a large town in the south of Naples, and capital of Calabria Ultra, at the extremity of which it is situated, on the Faro di Messina, or strait which separates Sicily from the main land. It stands on an eminence, and its environs are delightful, abounding in the fruits of a tropical climate. It is the see of an archbishop, and several of the houses are constructed of the remains of ancient buildings. Its public edifices consist of a cathedral, eleven churches, seven convents, and two colleges. Many of the inhabitants are employed in the manufacture of silk, partly raised in the environs, and partly procured from the pinna marina: it is made into gloves, stockings, and other small articles of extreme fineness. Wine, oil, and fruit are likewise objects of export. Reggio was almost destroyed by the dreadful earthquake of February 1783. Population 16,500. Six miles south-east of Messina, in Sicily, and thirty-three north by west of Nicotera.

**REGGIO**, anciently Regium Lepide, a town in the north of Italy, the capital of a small duchy of the same name, belonging to Modena. It is surrounded with a rampart, and situated in a

delightful track on the Tessino. The streets are bordered with arcades or piazzas, and the houses tolerably built. The public edifices of interest are the cathedral with its paintings, the church of St. Prospero, that of the Augustine friars, the town house, the theatre, the Porta Nuova, the library of 30,000 volumes, and a museum of natural history, formerly belonging to Spallanzani. The trade is trifling, but it has a considerable yearly fair. It was the birth place of Ariosto, and Buonaparte gave the title of duke of Reggio to marshal Oudinot. Population 13,000. Twelve miles W. N. W. of Modena, and fifteen south-east of Parma.

**REG'ICIDE**, *n. s.* Lat. *regicida*, *regicidium*. A murderer of his king; the murder of a king.

Were it not for this amulet, how were it possible for any to think they may venture upon perjury, sacrilege, murder, *regicide*, without impeachment to their saintship?  
*Decay of Piety.*

I through the mazes of the bloody field  
Hunted your sacred life; which that I missed  
Was the propitious error of my fate,  
Not of my soul: my soul's a *regicide*. *Dryden.*

Did fate or we, when great Atrides died,  
Urge the bold traitor to the *regicide*?  
*Pope's Odyssey.*

**REGIFUGIUM** was a feast celebrated at Rome on the 24th of February in commemoration of the expulsion of Tarquin II., and the abolition of regal power. It was also performed on the 26th of May, when the Rex Sacrorum, king of the sacrifices, offered bean flour and bacon, in the place where the assemblies were held. The sacrifice being over, the people hastened away with all speed, to denote the precipitate flight of Tarquin.

**REGILLÆ**, or **REGILLUM**, an ancient town of Italy, in the country of the Sabines, famous for a battle fought near it, A. U. C. 258, between 24,000 Romans and 40,000 Etrurians, headed by the Tarquins. The Romans obtained so complete a victory that hardly 10,000 of the Etrurians escaped.—Livy.

**REGILLIANUS** (Q. Nonius), a Dacian, who entered into the Roman army, and was promoted to the highest military honors under Valerian. He was elected emperor by the people in opposition to Gallienus, but was soon after murdered by the soldiers, A. D. 262.

**REGILLUS**, in ancient geography, a lake of Italy, in Latium, which had a communication with the Anio, east of Rome. Posthumius, the dictator, defeated the Latins near it.—Livy.

**REG'IMEN**, *n. s.* Lat. *regimen*. Care in diet and living.

Yet should some neighbour feel a pain,  
Just in the parts where I complain,  
How many a message would he send!  
What hearty prayers, that I should mend!  
Enquire what *regimen* I kept,  
What gave me ease, and how I slept? *Swift.*

**REGIMEN**, in medicine. See **MEDICINE**.

**REG'IMENT**, *n. s.* } Old Fr. *regiment*;  
**REGIMEN'TAL**, *adj.* } Ital. and Port. *regimento*.  
Established government; polity; a body of soldiers under a colonel: belonging to a regiment.

The corruption of our nature being presupposed.

we may not deny but that the law of nature doth now require of necessity some kind of *regiment*.

*Hooker.*

Higher to the plain we'll set forth,  
In best appointment, all our *regiments*. *Shakspeare.*

They utterly damn their own consistorian *regiment*, for the same can neither be proved by any literal texts of holy scriptures, nor yet by necessary inference out of scripture.

*White.*

The *regiment* of the soul over the body is the *regiment* of the more active part over the passive.

*Hale.*

The elder did whole *regiments* afford,  
The younger brought his conduct and his sword.

*Waller.*

Now thy aid

Eugene, with *regiments* unequal preat,  
Awaits.

*Philips.*

**REGIMENT**, in military affairs, a term applied to any body of troops, which, if cavalry, consists of one or more squadrons, commanded by a colonel; and, if infantry, of one or more battalions, each commanded in the same manner. The squadrons in cavalry *regiments* are divided, sometimes into six, and sometimes into nine troops. The battalions of British infantry are generally divided into ten companies, two of which are called the flanks; one on the right consisting of grenadiers, and another on the left formed of light troops. There is not, however, any established rule on this head; as both cavalry and infantry *regiments* differ according to the exigencies of service in time of war, or the principles of economy in time of peace.

**REG'ION**, *n. s.* French *region*; Latin *regio*. Tract of land; country; space; place; rank.

All the *regions*

Do seemingly revolt; and, who resist,

Are mocked for valiant ignorance. *Shakspeare.*

The bow is bent and drawn, make from the shaft.  
—Let it fall rather, though the fork invade

The *region* of my heart.

*Id. King Lear.*

The gentleman kept company with the wild prince and Poiias; he is of too high a *region*; he knows too much.

*Shakspeare.*

The upper *regions* of the air perceive the collection of the matter of tempests before the air below.

*Bacon.*

Thus raged the goddess, and with fury fraught,  
The restless *regions* of the storms she sought.

*Dryden.*

**REG'ISTER**, *n. s. & v. a.* } Fr. *registre*; Lat.

**REG'ISTRY**. } *registrum*. A regul-

lar account of any thing; he who keeps it: to record or enrol in a register: registry is the act of doing so; the series of entries; or the place where they are kept.

Joy may you have and everlasting fame,

Of late most hard achievement by you done,

For which inrolled is your glorious name

In heavenly registers above the sun. *Spenser.*

Sir John, as you have one eye upon my follies, as you hear them unfolded, turn another into the register of your own.

*Shakspeare.*

This island, as appeareth by faithful registers of those times, had ships of great content.

*Bacon.*

Such follow him, as shall be registered;

Part good; part bad; of bad the longer scowl.

*Milton.*

A little fee was to be paid for the *registry*. *Graunt.*

Of these experiments our friend, pointing at the register of this dialogue, will perhaps give you more particular account.

*Boyle.*

I wonder why a *registry* has not been kept in the college of physicians of things invented. *Temple.*

For a conspiracy against the emperor Claudius, it was ordered that Scribonianus's name and consulate should be effaced out of all public registers and inscriptions.

*Addison.*

The Roman emperors registered their most remarkable buildings, as well as actions. *Id.*

A REGISTER is a public book, in which are entered and recorded memoirs, acts, and minutes, to be had recourse to occasionally for knowing and proving matters of fact. Of these there are several kinds; as, 1. Register of deeds in Yorkshire and Middlesex, in which are registered all deeds, conveyances, wills, &c., that affect any lands or tenements in these counties, which are otherwise void against any subsequent purchasers or mortgages, &c.: but this does not extend to any copyhold estate, nor to leases at a rack-rent, or where they do not exceed twenty-one years. The registered memorials must be engrossed on parchment, under the hand and seal of some of the granters or grantees, attested by witnesses who are to prove the signing or sealing of them and the execution of the deed. But these registers, which in England are confined to two counties, are in Scotland general. Of these there are two kinds; the one general, fixed at Edinburgh, under the direction of the lord register; and the other is kept in the several shires, stewardries, and regalities, the clerks of which are obliged to transmit the registers of their respective courts to the general register. 2. Parish registers are books in which are registered the baptisms, marriages, and burials of each parish.

Among dissenters who admit of infant baptism, the minister is generally supposed to keep a register of the several children baptized by him. But as these are frequently lost, by the succession of new ministers to the same congregation; or at best do not give an account of the date of the births, which may have happened many weeks or months before baptism, it is now generally the custom among dissenters of all denominations to register the births of their children at the library in Redcross Street, Cripplegate, for which the charge is 1s. This register is admitted in the courts of law.

REGISTERS were kept both at Athens and Rome, in which were inserted the names of children, as soon as they were born. Marcus Aurelius required all free persons to give an account of their children, within thirty days after the birth, to the treasurer of the empire, in order that they might be deposited in the temple of Saturn, where the public acts were kept. Officers were also appointed as public registers in the provinces, that recourse might be had to their list of names, for settling disputes, or proving any person's freedom.

REGISTERS, in chemistry, are holes, with stopples, contrived in the sides of furnaces, to regulate the fire; that is, to make the heat more intense or remiss, by opening them to let in the air, or keeping them close to exclude it.

REGISTRY OF A SHIP is a printed instrument, containing the names of the owner and master, the name and exact description of the vessel, the place to which she belongs, when and where

built or captured, and, if a prize-ship, the date of condemnation, whether British, foreign, or British plantation built, her precise dimensions, tonnage, and the port at which she was registered.

REGIUM, REGIUM LEPIDI, or REGIUM LEPIDIUM, in ancient geography, a town of Cisalpine Gaul, on the Via Emilia, so called from Æmilius Lepidus, who was consul with Caius Flaminius. It is now called Reggio.

REGIUS (Urban), a learned writer of the sixteenth century, born at Langenargen. He studied at Basil, and read lectures at Ingoldstadt. Being afterwards involved by some friends in debt, he was obliged to sell his books and enlist as a soldier. From this situation he was rescued and restored to literature by professor Eccius; and he obtained the poetical and oratorical crown from the emperor Maximilian. He afterwards became a protestant, and took refuge at Zell, where he died in 1541.

REGIUS PROFESSOR, in universities, a professor appointed by royal authority.

REGLEMENT, *n. s.* Fr. *reglement*. Regulation. Not used.

To speak of the reformation and *reglement* of usury, by the balance of commodities and discommodities thereof, two things are to be reconciled.

*Bacon's Essays.*

REGNANT, *adj.* Fr. *regnant*. Reigning; having sovereign authority; predominant.

Princes are shy of their successors, and there may be reasonably supposed of queens *regnant* a little proportion of tenderness that way, more than in kings.

*Watton.*

The law was *regnant*, and confined his thought, Hell was not conquered when the poet wrote.

*Waller.*

His guilt is clear, his proofs are pregnant.  
A traitor to the vices *regnant*. *Swiss's Miscellanies.*

REGNARD (John Francis), a French comic poet, was born at Paris, February 8th, 1655. Having received a good education he went to Italy in 1676, or 1677. Being fond of play, and very fortunate, he was returning home with a considerable sum of money, when he was captured by an Algerine corsair, and being sold for a slave was carried to Constantinople. His skill in cookery here rendered him a favorite; but at length he was ransomed, and returned to France. He did not however remain; for in April 1681 he set off on a journey to Lapland, and returned through Sweden, Poland, and Germany. He then retired to Dourdan, eleven leagues from Paris, where he died in September 1709. He wrote an account of his Northern Tour; a number of dramatic pieces, poems, and other works, which have been often published.

REGNAULT (Noel), a learned French Jesuit, born at Arras, in 1683. He wrote, 1. *Entretiens Physiques*, 3 vols. 12mo. 2. *Origine Ancienne de la Physique nouvelle*, 3 vols. 12mo. 3. *Entretiens Mathematiques*, 3 vols. 12mo. 4. *Logique*, 12mo.

REGNER, surnamed Lodbrog, a king of Denmark, who flourished in the ninth century. He was also a warrior, a poet, and a painter. His poems are extant, but savour of the wildness and fanaticism of the age in which he lived.

REGNI, an ancient people of South Britain, who inhabited the country now called Surrey, Sussex, and the coast of Hampshire, and resided next to the Cantii, the ancient inhabitants of Kent.—Camden.

REGNIER (Mathurin), a French poet, was born at Chartres in 1573. He was brought up to the church, for which his debaucheries rendered him very unsuitable. Yet he obtained a canonry in the church of Chartres, with other benefices; and died in 1613. There is a neat Elzevir edition of his works, 12mo. 1652, Leyden; but the most elegant is that with notes by M. Brossette, 4to. 1729, London.

REGNIER DES MARETS (Francis Seraphin), a French poet, born at Paris in 1632. He distinguished himself early by his poetical talents, and in 1684 was made perpetual secretary to the French Academy on the death of Mezeray; when he drew up the papers against Furetiere; the king gave him the priory of Grammont, and an abbey. He died in 1713. His works are French, Italian, Spanish, and Latin poems, 2 vols.; a French grammar; and an Italian translation of Anacreon's Odes, with some other translations.

REGNUM, in ancient geography, a town of South Britain, the capital of the Regni (Camden), situated by the Itinerary numbers, on the confines of the Belgæ, in a place now called Ringwood, in Hampshire, on the Avon, about ten miles from the sea.

REGORGE, *v. a.* Re and gorge. To vomit up; throw or swallow back; swallow largely.

It was scoffingly said, he had eaten the king's goose; and did then *regorge* the feathers.

*Haycard.*

Drunk with wine,  
And fat *regorged* of bulls and goats. *Milton.*  
As tides at highest mark *regorge* the flood,  
So fate, that could no more improve their joy,  
Took a malicious pleasure to destroy. *Dryden.*

REGRAFT, *v. a.* Fr. *regreffir*. Re and graft. To graft again.

Of *regrafting* the same cions, may make fruit greater. *Bacon.*

REGRANT, *v. a.* Re and grant. To grant back.

He, by letters patent, incorporated them by the name of the dean and chapter of Trinity church a Norwich, and *regranted* their lands to them.

*Ayliffe's Physico-Theology.*

REGRATE, *v. a.* From GRATE, which see. To offend; shock; also, from the French *regrater*, to engross; forestall.

Neither should they buy any corn, unless it were to make malt thereof; for by such engrossing and *regrating*, the dearth, that commonly reigned in England, hath been caused. *Spenser.*

The clothing of the tortoise and viper rather *regrate*th than pleaseth the eye.

*Derham's Physico-Theology.*

REGREET, *v. a.* Re and greet. To resalute; greet a second time.

And shall these hands, so newly joined in love,

Take this seizure, and this kind *regreet*?

Play fast and loose with faith? *Shakespeare.*

REGRESS, *n. s.* & *v. n.* } Fr. *regress*; Lat.  
REGRES'SION, *n. s.* } *regressus*. Passage

back; power of passing back : to go back, or return; act of going back.

All being forced unto fluent consistencies, naturally regress into their former solidities. *Broune.*

To desire there were no God, were plainly to un-wish their own being, which must needs be annihilated in the subtraction of that essence which substantially supporteth them, and restrains from regression into nothing. *Id.*

'Tis their natural place which they always tend to : and from which there is no progress nor regress. *Burnet.*

REGRET, n. s. & v. a. Fr. *regret. regreter*; Ital. *regrettare*, of low Lat. *regrevito*. Vexation at some past event or action; bitter reflection; grief; sorrow; aversion : to grieve at; bemoan; be uneasy at. The last senses of both the noun-substantive and verb active are, however, improper.

I never bare any touch of conscience with greater regret. *King Charles.*

A passionate regret at sin, a grief and sadness at its memory, enters us into God's roll of mourners. *Decay of Piety.*

Is it a virtue to have some ineffective regrets to damnation, and such a virtue too as shall balance all our vices? *Id.*

Never any prince expressed a more lively regret for the loss of a servant, than his majesty did for this great man; in all offices of grace towards his servants, and in a wonderful solicitous care for the payment of his debts. *Clarendon.*

Those, the impiety of whose lives makes them regret a deity, and secretly wish there were none, will greedily listen to atheistical notions. *Glanville.*

I shall not regret the trouble my experiments cost me, if they be found serviceable to the purposes of respiration. *Boyle.*

Though sin offers itself in never so pleasing a dress, yet the remorse and inward regrets of the soul, upon the commission of it, infinitely overbalance those faint gratifications it affords the senses. *South's Sermons.*

That freedom which all sorrows claim,  
She does for thy content resign;  
Her piety itself would blame,  
If her regrets should waken thine. *Prior.*

Calmly he looked on either life, and here  
Saw nothing to regret, or there to fear;  
From nature's temperate feast rose satisfied,  
Thank'd heaven that he had liv'd, and that he died. *Pope.*

REGUERDON, n. s. Re and guerdon.  
Reward; recompense.

Stoop, and set your knee again my foot;  
And in *reguerdon* of that duty done,  
I gird thee with the valiant sword of York. *Shakespeare.*

Long since we were resolved of your truth,  
Your faithful service, and your toil in war;  
Yet never have you tasted of your reward,  
Or been *reguerdoned* with so much as thanks. *Id.*

REGULAR, adj. & n. s. } Fr. *regulier*;  
REGULARITY, n. s. } Port. and Spanish  
REGULARLY, adv. } *regular*; Ital. *re-*  
REGULATE, v. a. } *gulare*; low Lat.  
REGULATION, n. s. } *regularis*. Ac-  
REGULATOR. } cording to rule;

or prescribed mode; initiated; orderly : in geometry, a regular body is a solid whose surface is composed of regular and equal figures, and whose solid angles are all equal, and of which there are, and can be, but five sorts : as a noun-

substantive, an order of Romish clergy: regularly and regularity follow the senses of the adjective : to regulate is to adjust or direct by rule or method, the noun-substantives corresponding.

I restrained myself to so regular a diet, as to eat flesh but once a day, and little at a time, without salt or vinegar. *Temple.*

So bold, yet so judiciously you dare,  
That your least praise is to be regular. *Dryden.*  
Even goddesses are women; and no wife  
Has power to regulate her husband's life. *Id.*

Nature, in the production of things, always designs them to partake of certain, regulated, established essences, which are to be the models of all things to be produced; this, in that crude sense, would need some better explanation. *Locke.*

Being but stupid matter, they cannot but continue any regular and constant motion, without the guidance and regulation of some intelligent being. *Flau.*

Regularity is certain, where it is not so apparent, as in all fluids; for regularity is a similitude continued. *Crew.*

The regularity of corporeal principles sheweth them to come at first from a divine regulator. *Id.*

The common cant of critics is, that though the lines are good, it is not a regular piece. *Guardian.*

The ways of heaven are dark and intricate;—  
Our understanding traces them in vain,—  
Nor sees with how much art the windings run,  
Nor where the regular confusion ends. *Addison.*

In the Romish church, all persons are said to be regulars, that do profess and follow a certain rule of life, in Latin styled regula. *Ayliffe's Parergon.*

With one judicious stroke  
On the plain ground Apelles drew  
A circle regularly true. *Prior.*  
He was a mighty lover of regularity and order;  
and managed all his affairs with the utmost exactness. *Atterbury.*

Regulate the patient in his manner of living. *Wiseman.*

There is no universal reason, not confined to human fancy, that a figure, called regular, which hath equal sides and angles, is more beautiful than any irregular one. *Bentley.*

So when we view some well-proportioned dome,  
No monstrous height or breadth or length appear;  
The whole at once is bold and regular. *Pope.*

Strains that neither ebb nor flow,  
Correctly cold and regularly low. *Id.*  
More people are kept from a true sense and taste of religion, by a regular kind of sensuality and indulgence, than by gross drunkenness. *Law.*

A REGULAR FIGURE, in geometry, is one whose sides, and consequently angles, are equal; and a regular figure with three or four sides is commonly termed an equilateral triangle or square, as all others with more sides are called regular polygons.

REGULBIUM, or REGULVIUM, an ancient town of the Cantii in Britain, mentioned in the Notitia Imperii, now called Reculver.

REGULUS (M. Attilius), a Roman consul during the first Punic war. He reduced Brundisium, and, in his second consulship, took sixty-four and sunk thirty galleys of the Carthaginian fleet, on the coasts of Sicily. Afterwards he landed in Africa; and so rapid was his success, that in a short time he made himself master of about 200 important places on the coast. The Carthaginians sued for peace, but he refused to grant it; and soon after he was de-

feated by Xantippus, and 30,000 of his men were killed, and 15,000 taken prisoners. Regulus himself was also taken, and carried in triumph to Carthage. He was then sent to Rome, to propose an accommodation; and, if his commission was unsuccessful, he was bound by the most solemn oaths to return to Carthage. When he came to Rome, Regulus dissuaded his countrymen from accepting the terms which the enemy proposed; and, when his opinion had influenced the senate, Regulus returned to Carthage agreeable to his oaths. The Carthaginians, hearing that their offers of peace had been rejected at Rome through the influence of Regulus, prepared to punish him with the greatest severity. His eye-lids were cut off, and he was exposed for some days to the excessive heat of the meridian sun, and afterwards confined in a barrel, whose sides were stuck with iron spikes, till he died in the greatest agonies. His sufferings being heard of at Rome, the senate permitted his widow to inflict whatever punishment she pleased on some of the most illustrious captives of Carthage, who were in their hands. She confined them in presses filled with sharp iron points; and was so exquisite in her cruelty that the senate at length interfered, and stopped her barbarity. Regulus died about A. A. C. 251.

REGULUS (Memmius), a Roman, made governor of Greece by Caligula. While Regulus governed this province, the emperor wished to bring the celebrated statue of Jupiter Olympius by Phidias to Rome; but this was supernaturally prevented, according to ancient authors, the ship which was to convey it being destroyed by lightning.

REGULUS, in chemistry, diminutive of rex, a king: so called because the alchemist expected to find gold, the king of metals, collected at the bottom of the crucible after fusion. The name regulus was given by chemists to metallic matters when separated from other substances by fusion. It was afterwards applied to the metal extracted from the ores of the semi-metals, which formerly bore the name that is now given to the semi-metals themselves. To procure the regulus or mercurial parts of metals, &c., flux powders were formerly used, as nitre, tartar, &c., to purge the sulphureous part adhering to the metal, by attracting it to themselves, and absorbing it.

REGURGITATE, *v. a. & v. n.* } Fr. *regor-*  
REGURGITATION, *n. s.* } *ger*: Latin  
*re* and *gurgēs*. To throw back; pour back: be poured back: the act of resorption or swallowing back.

The inhabitants of the city remove themselves into the country so long, until for want of receipt and encouragement, it *regurgitates* and sends them back.  
*Graunt.*

Nature was wont to evacuate its vicious blood, out of these veins, which passage being stopt, it *regurgitates* upwards to the lungs.  
*Harvey on Consumptions.*

*Regurgitation* of matter is the constant symptom.  
*Sharp.*

Arguments of divine wisdom, in the frame of animate bodies, are the artificial position of many valves, all so situate as to give a free passage to the

blood in their due channels, but not permit them to *regurgitate* and disturb the great circulation.

REHEAR', *v. a.* } Re and hear. To hear  
REHEARSE, *v. a.* } again; repeat; recite;  
REHEARSAL, *n. s.* } relate: rehearsal is the act of repetition or recital; recital previous to a public exhibition.

*Bentley.*  
*Rehearse* not unto another that which is told. *Æclus.*  
Twice we appoint that the words which the minister pronounceth the whole congregation shall repeat after him; as first in the public confession of sins, and again in rehearsal of our Lord's prayer after the blessed sacrament.  
*Hooker.*

What dream'd my lord? tell me, and I'll requite it  
With sweet rehearsal of my morning's dream.  
*Shakspeare.*

The chief of Rome,  
With gaping mouths to these rehearsals come.  
*Dryden.*

Great master of the muse! inspired  
The pedigree of nature to *rehearse*,  
And sound the Maker's work in equal verse. *Id.*  
What respected their actions as a rule or admonition, applied to yours, is only a *rehearsal*, whose zeal in asserting the ministerial cause is so generally known.  
*South.*

My design is to give all persons a *rehearing*, who have suffered under my unjust sentence. *Addison.*

Of modest poets be thou just,  
To silent shades repeat thy verse,  
Till fame and echo almost burst,  
Yet hardly dare one line *rehearse*. *Swift*  
But a' your doings to *rehearse*,  
Your wily snares an fechtin fierce,  
Sin' that day Michael did you pierce

Down to this time,  
Wad ding a' Lallan tongue or Erse,  
In prose or rhyme. *Burns.*

The lover, in melodious verses,  
His singular distress *rehearses*,  
Still closing with a rueful cry,  
Was ever such a wretch as I! *Couper.*

REHER, a district of Delhi, Hindostan, situated between lat. 28° and 29°. It formerly was the northern limit of Kuttaher or Rohilcund, and was ceded to the British by the nabob of Oude. It is bounded on the west by the Ganges, and watered by several other rivers. The principal towns are Reher, Nijibabad, and Darnagur.

REHER, a town of Hindostan, formerly the capital of the above district, became in 1774 the property of a chief named Nijif Khan, who removed the seat of government to Nijibabad, in consequence of which Reher has declined. The town and district are now included in the British collectorship of Bareilly. Long. 78° 44' E., lat. 29° 23' N.

REHOBOAM, the son of Solomon, king of Israel, succeeded his father about A. M. 3029. By his folly, in totally refusing the people any redress of grievances, he occasioned the revolt of the ten tribes. See 1 Kings xii. 1—24. After an unfortunate reign of seventeen years, during which his capital was invaded and the temple plundered of its treasures by Shishak, or Sesacus, king of Egypt, he died A. M. 3046.

REJANG, a country of Sumatra, divided to the north-west from the kingdom of Anak Sunger by the river Uri, near that of Kattaun; which last, with the district of Labun, bounds it on the

north side. The country of Musi is its limit to the eastward. Bencoolen River confines it on the south-east.

**REICHENBACH**, one of the four governments of Prussian Silesia. It is in the west of that province, and comprises the county of Glatz, the principalities of Munsterberg, Brieg, and Schweidnitz, and a considerable part of the Jauer. Its area is 2500 square miles. It is divided into the circles of Frankenstein, Glatz, Hirschberg, Jauer, Nimptsch, Munsterberg, Reichenbach, Schweidnitz, Striegau, and Bolkenhain-Landshut. Population 470,000.

This province is hilly, particularly in the county of Glatz; but has also many plains, fertile in corn, fruits, hops, and occasionally mulberry-trees. Among the mountains wood forms an article of export. In general this is the most active part of Silesia, and consequently of the Prussian states. The chief manufactures are linen, glass, and hardware. The number of villages is very great. The province being very populous, it is necessary to import corn. In the county of Glatz, and the principality of Munsterberg, the Catholics form the majority; but throughout the rest the Protestants.

**REICHENBACH**, the chief town of the above government, is eleven miles south-east of Schweidnitz, and thirty south-west of Breslau. It has manufactures of cotton, canvas, starch, and a trade in woollens. A convention was concluded here in 1790 between Prussia and Austria. Inhabitants 3300. Long. 16° 36' 37" E., lat. 50° 39' 15" N.

**REICHENBACH**, a town of Saxony, in the Vogtland. Its inhabitants, about 3000, are employed chiefly in the manufacture of woollens. Their mode of dyeing scarlet is much esteemed. This town suffered much from fire in 1681 and 1720. Thirteen miles N. N. E. of Plauen.

**REICHENBACH**, a river of the canton of Berne, Switzerland, in the district of Oberland. It is small, but, when swelled by the melted snow of the Alps, pours a large mass of water over a tremendous precipice.

**REICHENBERG**, a thriving town of Bohemia, in the northern circle of Buntzlau, on the Neisse; the chief place of a lordship belonging to the count of Clam-Galla. It has three churches, and great manufacturing establishments for woollens, with fulling-mills and dye-houses. The value of the woollen, linen, and stockings, annually made, is estimated at more than half a million; there is also a traffic in wool and yarn. In the neighbourhood are found precious stones of the finer and semi-transparent kinds. On the 21st of April, 1757, the Prussians, under the duke of Brunswick, obtained a victory here over the Austrians. Inhabitants 12,000. Fifty-two miles N. N. E. of Prague, and twenty-five N. N. E. of Jurg Buntzlau.

**REICHENHALL**, a town in the south-east of Bavaria, on the Sala, sixty-five miles E. S. E. of Munich, and eleven S. S. W. of Salzburg. It is of great importance on account of its salt-works, at which 16,000 tons of that mineral are annually produced.

**REID** (Thomas), D. D., a late eminent Scottish writer, was the son of the Rev. Lewis Reid.

He was born at Strachan in April, 1710, and educated first at the parish school of Kincardine O'Neil, whence he was sent to the Marischal college, Aberdeen, in his 12th year; where he took his degree of M. A. and studied theology. After obtaining his license he cultivated mathematics under professor John Stuart, whose place he often supplied in his absence. After this he was preferred to the church of New Machar, and soon overcame the popular prejudice against him, on account of that patronage. On the 22d Nov. 1751, he was appointed professor of philosophy in King's College, Aberdeen; an office for which he was peculiarly qualified. Soon after this he wrote his *Essay on Quantity*, published in the *Philosophical Transactions*, vol. 45; which is esteemed the finest specimen of metaphysical mathematics extant. About this time, too, he was made D. D., and published his celebrated *Enquiry into the Human Mind*, on the principles of Common Sense. On the death of Dr. Adam Smith, he was called to be professor of moral philosophy in the university of Glasgow, on the eleventh of June, 1764. In 1773 appeared in lord Kames's *Sketches of the History of Man*, a brief Account of Aristotle's *Logic*, with Remarks by Dr. Reid; which is esteemed the best analysis yet given of that philosopher's writings. In 1785 he published *Essays on the Intellectual Powers of Man*, dedicated to Dr. Gregory and professor Stewart of Edinburgh; and, in 1788, *Essays on the active Powers of Man*; both in 4to. He died in October 1796, aged eighty-seven. He had been married, and left one daughter. See **METAPHYSICS**.

**REICHSTADT** (duke of). The emperor, Francis I., bestowed the title of duke of Reichstadt on his grandson Napoleon Francis Joseph Charles (born March 20, 1811), son of Napoleon and Maria Louisa, daughter to Francis I. and duchess of Parma. The letters patent (of July 22, 1818) granted the young prince the dignity of serene highness, with a rank next after the princes of the blood, and a particular coat of arms. The revenue of the lordship, consisting of the fourteen Tuscan estates, is about 400,000 guilders, or about 160,000 dollars. Whenever Lucca passed into the possession of the grand-duke of Tuscany, this lordship was to fall to the duke. The duke of Reichstadt resided at Vienna. Previously to his birth he was designated as king of Rome; and a few days after his baptism he received the homage of the different authorities, whom the countess of Montesquieu, as governess of France, answered in his name. After the fall of Napoleon, he was placed under the care of his grandfather, who, at first, destined him for the church, but afterwards gave him a military education. He had excellent teachers, as, for instance, Von Hammer. In Austrian and other German official papers, his name is given as Francis Joseph Charles only. After much suffering from a lingering consumption, he died almost unremembered by the French nation, of which he had once been the idol, on the 22nd of July, 1832.

**REJECT**, *v. a.* †. Lat. *reicio, rejectus*. To REJECTION, *n. s.* † dismiss without complacence; refuse; cast off: the act of casting off or aside.

**REIGLE**, *n. s.* *Fr. regle.* A hollow cut to guide any thing.

A flood gate is drawn up and let down through the *reigles* in the side posts. *Carew.*

**REIGN**, *v. n. & n. s.* *Fr. regner*; *Span. and Port. reyne*; *Ital. and Lat. regno.* To exercise sovereign authority; obtain power; be predominant: royal authority; sovereignty; power

And he schal *regne* in the hous of Jacob withouten ende, and of his rewme schal be noon ende. *Wiclif. Luk. 1.*

A king shall *reign* in righteousness, and princes rule in judgment. *Isaiah xxxi. 1.*

That, as sin *reigned* unto death, even so might grace *reign*, through righteousness, unto eternal life by Jesus Christ. *Romans.*

This, done by them, gave them such an authority, that, though he *reigned*, they in effect ruled, most men honouring them, because they only deserved honour. *Sidney.*

Tell me, shall Banquo's issue ever

*Reign* in this kingdom? *Shakspeare. Macbeth.*  
More are sick in the summer, and more die in the winter, except in pestilent diseases, which commonly *reign* in summer or autumn. *Bacon.*

The year againe

Was turning round; and every season's *raigne* Renewed upon us. *Chapman.*  
Did he not first seven years, a life-time *reign*? *Cowley.*

Great secrecy *-eigns* in their publick councils. *Addison.*

Saturn's sons received the threefold *reign* Of heaven, of ocean, and deep hell beneath. *Prior.*

The following licence of a foreign *reign*, Did all the dregs of bold Socinus drain. *Pope.*

That wrath which hurled to Pluto's gloomy *reign*, The souls of mighty chiefs untimely slain. *Id.*

Russel's blood

Stained the sad annals of a giddy *reign*. *Thomson.*

This right arm shall fix

Her seat of empire; and your son shall *reign*. *A. Philips.*

**REIMBODY**, *v. n.* *Re* and *imbody*. To embody again.

Quicksilver, broken into little globes, the parts brought to touch immediately *reimbody*. *Boyle.*

**REIMBURSE'**, *v. a.* *Fr. re, in, and bourse* a purse. To repay; repair loss or expense.

If any person has been at expence about the funeral of a scholar, he may retain his books for the *reimbursement*. *Ayliffe.*

Hath he saved any kingdom at his own expences to give him a title of *reimbursing* himself by the destruction of ours? *Swift.*

**REIMPREG'NATE**, *v. a.* *Re* and *impregnate*. To impregnate anew.

The vigour of the loadstone is destroyed by fire, nor will it be *reimpregnated* by any other magnet than the earth. *Browne.*

**REIMPRES'SION**, *n. s.* *Re* and *impression*. A second or repeated impression.

Religion, of which the rewards are distant, and which is animated only by faith and hope, will glide by degrees out of the mind, unless it be invigorated and *-eimpres'sed* by external ordinances, by stated calls to worship, and the salutary influence of example. *Johnson.*

**REIN**, *n. s. &* *Fr. resnes*; *Ital. redeni.*

**REINS**. [*v. a.*] The part of a bridle which governs the horse's head; used metaphorically

for any instrument of government: 'to give the reins' is to give licence: to rein, to govern; restrain: reins, always in the plural, are from *Lat. renes*, *Gr. pesu*, the kidneys.

Whom I shall see for myself, though my *reins* be consumed. *Job.*

Every horse bears his commanding *rein*, And may direct his course as please himself. *Shakspeare.*

The hard *rein*, which both of them have borne Against the old kind king. *Id. King Lear.*

Being once chaf't, he cannot

Be *reined* again to temperance; then he speaks What's in his heart. *Id. Coriolanus.*

He mounts and *reins* his horse. *Chapman.*  
War to disordered rage, let loose the *reins*. *Milton.*  
He, like a proud steed *reined*, went haughty on. *Id.*

Take you the *reins*, while I from cares remove, And sleep within the chariot which I drove. *Dryden.*

His son retained

His father's art, and warrior steeds he *reined*. *Id.*  
With hasty hand the ruling *reins* he drew; He lashed the coursers, and the coursers flew. *Pope.*

When to his lust *Ægisthus* gave the *rein*, Did fate or we the adultrous act constrain? *Id.*  
Strip them of those false colours that so often deceive us; correct the sallies of the imagination, and leave the *reins* in the hand of reason. *Mason.*

**REINDEER**. See **CERVUS**.

**REINECCIUS** (*Reinier*), a learned German of the sixteenth century, born at Steinheim. He taught the belles lettres in the universities of Frankfort and Helmstadt. He published *Historia Julia*, and *Historia Orientalis*; with some other tracts. He died in 1595.

**REINESIUS** (*Thomas*), a learned German physician and philosopher, born at Gotha in Thuringia in 1587. He settled as a physician at Altemberg, where he was elected a burgo-master. He was afterwards appointed counsellor to the elector of Saxony, and resided at Leipsic. He wrote some tracts on medicine, but his chief works are on philology and criticism. His most celebrated work is *Variarum Lectionum Libri Tres*; 4to. He died at Leipsic in 1587.

**REINHOLD** (*Erasmus*), a learned German astronomer and mathematician, born at Salfeldt in Upper Saxony in 1511. He wrote several mathematical and astronomical works; and died in 1535.

**REINSPIRE'**, *v. a.* *Re* and *inspire*. To inspire anew.

Time will run

On smoother, till Favonius *reinspire* The frozen earth, and cloath in fresh attire The lily and rose. *Milton.*

The mangled dame lay breathless on the ground, When on a sudden, *reinspired* with breath, Again she rose. *Dryden.*

**REINSTAL'**, *v. a.* *Re* and *instal*. To seat again.

Thy father

Levied an army, weening to redeem, And *reinstal* me in the diadem. *Shakspeare.*

That alone can truly *reinstall* thee In David's royal seat, his true successor. *Milton.*

**REINSTATE'**, *v. a.* *Re* and *instate*. To put again in possession.



David, after that signal victory which had preserved his life, *reinstated* him in his throne, and restored him to the ark and sanctuary; yet suffered the loss of his rebellious son to overwhelm the sense of his deliverance. *Government of the Tongue.*

Modesty *reinstates* the widow in her virginity. *Addison.*

The *reinstating* of this hero in the peaceable possession of his kingdom was acknowledged. *Pope.*

**REINTEGRATE**, *v. a.* Fr. *reintegrer*; Lat. *re* and *integer*. To renew with regard to any state or quality; repair; restore.

This league drove all the Spaniards out of Germany, and *reintegrated* that nation in their ancient liberty. *Bacon.*

The falling from a discord to a concord hath an agreement with the affections, which are *reintegrated* to the better after some dislikes.

*Id. Natural History.*

**REJOICE'**, *v. n. & v. a.* } Fr. *rejouir*, To  
**REJOICER**, *n. s.* } be glad; exult; re-  
ceive pleasure from something past; exhilarate; make glad: the noun substantive corresponding.

Let them be brought to confusion that *rejoice* at mine hurt. *Psalms xxxv. 26.*

I will comfort them, and make them *rejoice* from their sorrow. *Jeremiah xxxi. 13.*

This is the *rejoicing* city that dwelt carelessly, that said, there is none beside me. *Zephaniah ii. 15.*

Whatsoever faith entertains, produces love to God; but he that believes God to be cruel, or a *rejoicer* in the unavoidable damnation of the greatest part of mankind, thinks evil thoughts concerning God. *Taylor's Rule of Holy Living.*

They *rejoice* each with their kind. *Milton.*

We should particularly express our *rejoicing* by love and charity to our neighbours. *Nelson.*

Alone to thy renown, 'tis given,

Unbounded through all worlds to go;

While she great saint *rejoices* heaven,

And thou sustains't the orb below. *Prior.*

I should give Cain the honour of the invention; were he alive, it would *rejoice* his soul to see what mischief it had made. *Arbuthnot.*

**REJOIN'**, *v. a. & v. n.* } Fr. *rejoindre*. To  
**REJOIN'DER**, *n. s.* } join or meet again; to  
reply to an answer: rejoinder is the reply made.

Injury or chance rudely beguiles our lips  
Of all *rejoindure*. *Shakespeare. Troilus and Cressida.*  
The quality of the person makes me judge myself obliged to a *rejoinder*. *Glanville to Albion.*

The grand signior conveyeth his galleys down to Grand Cairo, where they are taken in pieces, carried upon camels' backs, and *rejoined* together at Suez.

*Browne's Vulgar Errors.*

It will be replied that he receives advantage by this lopping of his superfluous branches; but I *rejoin*, that a translator has no such right. *Dryden.*

Thoughts, which at Hyde-park-corner I forgot,  
Meet and *rejoin* me in the pensive groat. *Pope.*

**REJOINER**, in law, is the defendant's answer to the plaintiff's replication or reply. Thus, in the court of chancery, the defendant puts in an answer to the plaintiff's bill, which is sometimes also called an exception; and the plaintiff's answer to that is called a replication, and the defendant's answer to that a rejoinder.

**REJOLT'**, *n. s.* Fr. *rejaillir*. Shock; succussion.

The sinner, at his highest pitch of enjoyment, is not pleased with it so much, but he is afflicted more; and, as long as these inward *rejolts* and recoilings of

the mind continue, the sinner will find his accounts of pleasure very poor. *South.*

**REISKE** (John James), M. D., a celebrated oriental scholar and critic, born in 1706, at a town in the duchy of Anhalt. After the usual school education he went, in 1733, to Leipsic, where he studied five years, acquired the Arabic language, and translated and published a book in it. He next travelled on foot to Leyden, where he was employed in arranging the Arabian MSS. though but poorly compensated for it. He next translated from the German and French into Latin various Essays sent him by Dorville, whom he had visited in his journey, and who inserted these in the *Miscellanea Critica*. At Dorville's desire he also translated the whole of the *Chariton* from the Greek, and *Abulfeda's Geography* from the Latin. He continued eight years in Leyden, and received his degree in it, but left it on account of calumnies excited against him by Peter Burnan, whose translation of *Petronius Arbiter* he had criticised. He then travelled through Germany, and settled at Leipsic, where he was made professor of Arabic, and continued for twelve years, writing for the booksellers. The *Acta Eruditorum* were greatly indebted to him. On the death of *Haltansius*, in 1756, he was made rector of the Academy at Leipsic, which placed him above want. Previously to this he had published his *Animadversiones in Auctores Græcos*, in five vols, a work of deep erudition. In 1764 he married *Ernestina Christina Muller*, a woman of extraordinary abilities, whose learning, particularly in Greek, was hardly inferior to his own. She assisted him in all his literary labors, especially in his immortal work of the *Édition of the Greek Orators*: in 12 vols, 8vo. Thus *Reiske* spent the remainder of his life; and died in 1774, universally respected. The number of his publications is very great. The principal are those above-mentioned and the following: *Dionysius Halicarnassensis*, seven vols; *Plutarch*, nine vols.; *Theocritus*, &c.

**REITERATE**, *v. a.* } Fr. *reiterer*; Lat. *re*  
**REITERATION**, *n. s.* } and *itero*. To repeat  
again and again: repetition.

You never spoke what did become you less  
Than this, which to *reiterate* were sin. *Shakespeare.*

With *reiterated* crimes he might

Heap on himself damnation. *Milton.*

It is useful to have new experiments tried over again; such *reiterations* commonly exhibiting new phenomena. *Boyle.*

Although Christ hath forbid us to use vain repetitions when we pray, yet he hath taught us that to *reiterate* the same requests will not be vain.

*Smaltridge.*

The words are a *reiteration* or reinforcement of an application, arising from the consideration of the excellency of Christ above Moses.

*Ward of Infidelity.*

**REJUDGE'**, *v. a.* Re and judge. To re-examine; review; re-try.

The muse attends thee to the silent shade;  
'Tis her's the brave man's latest steps to trace,  
*Rejudge* his acts, and dignify disgrace. *Pope.*

**REIZ**, or **REITZ** (*Frederic Wolfgang*), a German philologist, was born in Franconia, in 1733, and, after having completed his studies at Leipsic

sic, became a private tutor, and then a corrector of the press in the printing-office of Breitkopf. He held the professorships of philosophy, Latin and Greek, and poetry, and was director of the library belonging to the university of Leipsic. He died February 2, 1790. Reiz is principally known as the editor of Herodotus; but he published editions of other classics, and two Dissertations on Prosody.

**REKINDLE**, *v. a.* Re and kindle. To set on fire again.

These disappearing, fixed stars, were actually extinguished, and would for ever continue so, if not *rekindled*, and new recruited with heat and light.

*Cheyne's Philosophical Principles.*

*Rekindled* at the royal courts,  
Tumultuous love each beating bosom warms. *Pope.*

**RELAND** (Adrian), an eminent Orientalist, born at Rtyp, in North Holland, in 1676; and educated three years under Surenhusius, from whom he acquired the Hebrew, Syriac, Chaldee, and Arabic languages. In 1701 he was, by the recommendation of king William, appointed professor of Oriental languages and ecclesiastical antiquities in the university of Utrecht; and died of the small-pox in 1718. He was distinguished by his modesty, humanity, and learning; and carried on a correspondence with the most eminent scholars of his time. His works are written in Latin; viz. An excellent description of Palestine. Five dissertations on the Medals of the ancient Hebrews, and several other dissertations on different subjects. An Introduction to the Hebrew Grammar. The Antiquities of the Ancient Hebrews. On the Mahometan Religion.

**RELAPSE**, *v. n. & n. s.* Lat. *relapsus*. To slip back; slide or fall back; particularly from good to ill: relapse is regression; falling back into evil; return.

It was even as two physicians should take one sick body in hand; of which, the former would purge and keep under the body, the other pamper and strengthen it suddenly; whereof what is to be looked for, but a most dangerous *relapse*. *Spenser.*

Mark a bounding valour in our English;  
That being dead like to the bullet's grazing,  
Breaks out into a second course of mischief,  
Killing in *relapse* of mortality.

*Shakespeare. Henry V.*

The oftener he hath *relapsed*, the more significations he ought to give of the truth of his repentance.

*Taylor.*

This would but lead me to a worse *relapse*  
And heavier fall. *Milton.*

We see in too frequent instances the *relapses* of those, who under the present smart, or the near apprehension of the divine displeasure, have resolved on a religious reformation. *Rogers.*

He was not well cured, and would have *relapsed*.

*Wiseman.*

**RELATE**, *v. a. & v. n.* } Lat. *relatus*. To  
**RELATER**, *n. s.* } tell; recite; utter;  
**RELATION**, *n. s.* } give vent by words  
**RELATIVE**, *adj. & n. s.* } (a sense only used by  
**RELATIVELY**, *adv.* } Bacon); ally by kin-  
**RELATIVENESS**, *n. s.* } dred or marriage: as

a verb neuter, have reference or respect: a *relater* is, a narrator; historian: *relation*, narration; tale; connexion; manner of connexion, or of belonging to a person or thing; respect; reference; alliance; kindred; person related by birth or

marriage: *relative* is, respecting; considered as belonging to, or regarding, something else: as a noun substantive, somewhat respecting something else; the pronoun that answers to an antecedent; a kinsman or kinswoman: the adverb and noun substantive following correspond with *relative* as an adjective.

Learn the right joining of substantives with adjectives, and the *relative* with the antecedent.

*Ascham's Schoolmaster.*

Your wife and babes  
Savagely slaughtered; to *relate* the manner,  
Were to add the death of you.

*Shakespeare. Macbeth.*

I'll have grounds  
More *relative* than this. *Id.*

A man were better *relate* himself to a statue, than suffer his thoughts to pass in smother. *Bacon.*

Though capable it be not of inherent holiness, yet it is often *relative*. *Holyday.*

'Tis an evil dutifulness in friends and *relatives* to suffer one to perish without proof. *Taylor.*

Here I could frequent  
With worship place by place, where he vouchsafed  
Presence divine; and to my sons *relate*. *Milton.*

Her husband, the *relater*, she preferred  
Before the angel. *Milton's Paradise Lost.*

*Relations* dear, and all the charities  
Of father, son, and brother, first were known.

*Milton.*

We shall rather perform good offices unto *truth*, than any disservice unto their *relaters*. *Browne.*

Under this stone lies virtue, youth,

Unblemished probity and truth;

Just unto all *relations* known,

A worthy patriot, pious son, *Waller.*

All those things that seem so foul and disagreeable in nature are not really so in themselves, but only *relatively*. *Moss.*

Confining our care either to ourselves and *relatives*. *Fell.*

The drama presents to view, what the poem only does *relate*. *Dryden.*

I have been importuned to make some observations on this art, in *relation* to its agreement with poetry. *Id.*

Be kindred and *relation* laid aside,  
And honour's cause by laws of honour tried. *Id.*

All negative or privative words *relate* to positive ideas, and signify their absence. *Locke.*

*Relation* consists in the consideration and comparing of one idea with another. *Id.*

Not only simple ideas and substances, but modes are positive beings; though the parts of which they consist are very often *relative* one to another. *Id.*

When the mind so considers one thing that it sets it by another, and carries its own view from one to the other, this is *relation* and respect; and the denominations given to positive things, intimating that respect, are *relatives*. *Id.*

As other courts demanded the execution of persons dead in law; this gave the last orders *relating* to those dead in reason. *Tatler.*

Are we not to pity and supply the poor, though they have no *relation* to us? No *relation*! that cannot be: the gospel stiles them all our brethren; nay, they have a nearer *relation* to us, our fellow-members; and both these from their *relation* to our Saviour himself, who calls them his brethren. *Sprat.*

These being the greatest good or the greatest evil, either absolutely so in themselves, or *relatively* so to us; it is therefore good to be zealously affected for the one against the other. *Id.*

In an historical *relation*, we use terms that are most proper.

*Burnet's Theory of the Earth.*  
The ecclesiastical, as well as the civil governour, has cause to pursue the same methods of confirming himself; the grounds of government being founded upon the same bottom of nature in both, though the circumstances and *relative* considerations of the persons may differ.

So far as service imports duty and subjection, all created beings bear the necessary *relation* of servants to God.

The author of a just fable must please more than the writer of an historical *relation*.

Wholesome and unwholesome are *relative*, not real qualities.

Avails thee not,

To whom *related*, or by whom begot;

A heap of dust alone remains.

The best English historian, when his style grows antiquated, will be only considered as a tedious *re-later* of facts.

A she-cousin, of a good family and small fortune, passed months among all her *relations*.

Consider the absolute affections of any being as it is in itself, before you consider it *relatively* or survey the various *relations* in which it stands to other beings.

Our necessary *relations* to a family, oblige all to use their reasoning powers upon a thousand occasions.

Dependants, friends, *relations*,

Savaged by woe, forget the tender tie.

Our intercession is made an exercise of love and care for those amongst whom our lot is fallen, or who belong to us in a nearer *relation*: it then becomes the greatest benefit to ourselves, and produces its best effects on our own hearts.

Of the eternal *relations* and fitnesses of things we know nothing; all that we know of truth and falsehood is, that our constitution determines us in some cases to believe, in others to disbelieve.

**RELATIVE PRONOUNS**, in grammar, are those which answer to some other word foregoing, called the antecedent; such are the Latin pronouns *qui, quæ, quod, &c.*: in English, who, which, what, &c. The word answering to these relatives is often understood, as, I know whom you mean, for I know the person whom you mean.

**RELAX**, *v. a. & v. n.* } Lat. *relaxo*. To  
**RELAXATION**, *n. s.* } slacken; to make less tense; remit; ease; to be mild; remiss: the noun-substantive corresponding.

They childishly granted, by common consent of their whole senate, under their own seal, a *relaxation* to one Bertelier, whom the eldership had excommunicated.

The sinews, when the southern wind bloweth, are more *relaxed*.

Cold sweats are many times mortal; for that they come by a *relaxation* or forsaking of the spirits.

Adam, amazed,

Astonished stood, and black, while horror chill  
Ran through his veins, and all his joints *relax'd*.

It served not to *relax* their serried files.

The sea is not higher than the land, as some imagined the sea stood upon heap higher than the shore; and at the deluge, a *relaxation* being made, it overflowed the land.

In the book of games and diversions, the reader's mind may be supposed to be *relaxed*.

*Addison's Spectator.*

As God has not so devoted our bodies to toil, but that he allows us some recreation; so doubtless he indulges the same *relaxation* to our minds.

*Government of the Tongue.*

If in some regards she chose  
To curb poor Paulo in too close;  
In others she *relaxed* again,

And governed with a loose rein. *Prior.*  
Many who live healthy in a dry air, fall into all the diseases that depend upon *relaxation* in a moist one.

The statute of mortmain was at several times *relaxed* by the legislature.

The *relaxation* of the statute of mortmain is one of the reasons which gives the bishop terrible apprehensions of popery coming on us.

Nor praise *relax*, nor difficulty fright.

*Vanity of Wishes.*

**RELAY**, *n. s.* Fr. *relais*. Horses on the road to relieve others.

**RELEASE**, *v. a.* Fr. *relascher, relaxer*, of Lat. *relaxo*. To set free from confinement, servitude, pain, or penalty; free from obligation; quit; let go; relax: the noun-substantive corresponding.

Every creditor that lendeth aught unto his neighbour shall *release* it.

The king made a great feast, and made a *release* to the provinces, and gave gifts.

Pilate said, Whom will ye that I *release* unto you?

It may not seem hard, if in cases of necessity, certain profitable ordinances sometimes be *released*, rather than all men always strictly bound to the general rigour thereof.

The king would not have one penny abated, of what had been granted by parliament; because it might encourage other countries to pray the like *release* or mitigation.

Too secure, because from death *released* some days.

You *released* his courage, and set free

A valour fatal to the enemy.  
Why should a reasonable man put it into the power of fortune to make him miserable, when his ancestors have taken care to *release* him from her?

He had been base, had he *released* his right,  
For such an empire none but kings should fight.

O fatal search! in which the lab'ring mind,  
Still pressed with weight of woe, still hopes to find  
A shadow of delight, a dream of peace,  
From years of pain, one moment of *release*.

If solitude succeed to grief,

*Release* from pain is slight relief;

The vacant bosom's wilderness

Might thank the pang that made it less.

**RELEASE**, in law, is a discharge or conveyance of a man's right in lands or tenements, to another that hath some former estate in possession. The words generally used therein are, 'remised, released, and for ever quit-claimed.' And these releases may enure, either, 1. By way of enlarging an estate, as, if there be tenant for life or years, remainder to another in fee, and he in remainder releases all his right to the particular tenant and his heirs, this gives him the estate in fee. But in this case the releasee must be in possession of some estate for the release to work upon; for, if there be a lessee for years, and, before he enters and is in possession, the lessor releases

to him all his right in the reversion, such release is void for want of possession in the relessee. 2. By way of passing an estate, as, when one of two coparceners releaseth all his right to the other, this passeth the fee-simple of the whole. In both these cases there must be a privity of estate between the releasor and relessee; that is, one of their estates must be so related to the other as to make but one and the same estate in law. 3. By way of passing a right, as if a man be disseised, and releaseth to his disseisor all his right; hereby the disseisor acquires a new right, which changes the quality of his estate, and renders that lawful which before was tortious. 4. By way of extinguishment: as if my tenant for life makes a lease to A for life, remainders to B and his heirs, and I release to A; this extinguishes my right to the reversion, and shall enure to the advantage of B's remainder as well as of A's particular estate. 5. By way of entry and feoffment: as if there be two joint disseisors, and the disseisee releases to one of them, he shall be sole seised, and shall keep out his former companion; which is the same in effect as if the disseisee had entered, and thereby put an end to the disseisin, and afterwards had enfeoffed one of the disseisors in fee. When a man has in himself the possession of lands, he must at the common law convey the freehold by feoffment and livery, which makes a notoriety in the country: but if a man has only a right or a future interest he may convey that right or interest by a mere release to him that is in possession of the land: for the occupancy of the relessee is a matter of sufficient notoriety already.

**RELEGATION**, *n. s.* Fr. *relegation*; Lat. *relegatio*. Exile; judicial banishment.

According to the civil law, the extraordinary punishment of adultery was deportation or *relegation*.

*Ayliffe.*

**RELENT**, *v. n. & v. a.* } Fr. *relentir*. To  
**RELENTLESS**, *adj.* } soften; grow less  
 rigid or hard; melt; as a verb neuter, to  
 slacken; remit; mollify, but rarely used: the  
 adjective corresponds with the verb active.

I have marked in you a *relenting* truly, and a  
 slacking of the main career, you had so notably be-  
 gun, and almost performed. *Sidney.*

Apace he shot, and yet he fled apace,  
 And oftentimes he would *relent* his pace,  
 That him his foe more fiercely should pursue.

*Spenser.*

Can you behold  
 My tears, and not once *relent*?

*Shakespeare. Henry VI.*

In some houses, sweetmeats will *relent* more than  
 in others. *Bacon.*

Crows seem to call upon rain, which is but the  
 comfort they seem to receive in the *relenting* of  
 the air. *Id.*

The workmen let glass cool by degrees in such *re-*  
*lentings* of fire, as they call their healing heats, lest  
 it should shiver in pieces by a violent succeeding of  
 air. *Digby on Bodies.*

Undoubtedly he will *relent* and turn  
 From his displeasure. *Milton.*

Only in destroying, I find ease  
 To my *relentless* thoughts. *Id. Paradise Lost.*

Salt of tartar brought to fusion, and placed in a  
 cellar, will in a few minutes begin to *relent*, and  
 have its surface softened by the imbibed moisture of

the air, wherein, if it be left long, it will totally be  
 dissolved. *Boyle.*

Why should the weeping hero now  
*Relentless* to their wishes prove? *Prior.*

All nature mourns, the skies *relent* in showers,  
 Hush'd are the birds, and closed the drooping flow'rs;  
 If Delia smile, the flowers begin to spring,  
 The skies to brighten, and the birds to sing. *Pope.*

He sung, and hell consented

To hear the poet's prayer;  
 Stern *Proserpine* *relented*,

And gave him back the fair. *Id.*

**RELHAM** (Richard), F. R. S. and L. S., a re-  
 spectable divine and naturalist, was educated at  
 Cambridge, and became a fellow of King's Col-  
 lege. In 1791 he obtained the rectory of Hun-  
 ningsby, in Lincolnshire. His works are, *Flora*  
*Cantabrigensis*, in which he describes his dis-  
 covery of a new species of lichen and of the  
*athamanta libanotis*; and *Tacitus de Moribus*  
*Germanorum et de Vita Agricola*, 8vo.

**REL'ANCE**, *n. s.* From **RELY**, which see.

**REL'IC**, or **FR. RELIQUE**; Lat. *reliquia*.

**REL'ICK**, *n. s.* } Strictly that which remains;

**REL'ICLY**, *adv.* } that which is left after the  
 loss or decay of the rest: often applied to the  
 body after death, and to any thing kept as a re-  
 ligious memento.

Up dreary dame of darkness queen,

Go gather up the *reliques* of thy race,

Or else go them avenge. *Spenser.*

The fragments, scraps, the bits, and greasy *re-*  
*liques*,

Of her o'createn faith are bound to Diomedea.

*Shakespeare.*

Thrifty wench scrapes kitchen stuff,  
 And barrelling the droppings and the snuff  
 Of wasting candles, which in thirty year,

*Relickly* kept, perhaps buys wedding cheer. *Donne.*

What needs my Shakespeare for his honoured  
 bones,

The labour of an age in piled stones?

Or that his hallowed *reliques* should be hid

Under a starrypointed pyramid? *Milton.*

Nor death itself can wholly wash their stains,

But long contracted filth even in the soul remains;

The *relics* of inveterate vice they wear,

And spots of sin. *Dryden's Fneis.*

This church is very rich in *relics*; among the rest,  
 they show a fragment of Thomas à Becket, as indeed  
 there are very few treasuries of *relics* in Italy that  
 have not a tooth or a bone of this saint.

*Addison on Italy.*

Shall our *relics* second birth receive?

Sleep we to wake, and only die to live? *Prior.*

Thy *relics*, Rowe, to this fair shrine we trust,

And sacred place by Dryden's awful dust;

Beneath a rude and nameless stone he lies,

To which thy tomb shall guide enquiring eyes.

*Pope.*

**RELICS**, in the Romish church, the remains  
 of the bodies or clothes of saints or martyrs,  
 and the instruments by which they were put to  
 death, devoutly preserved, in honor of their me-  
 mory: revered, and carried in procession. The  
 respect which was due to the martyrs and teachers  
 of the Christian faith in a few ages increased  
 almost to adoration. Relics, therefore, were, and  
 still are preserved on the altars of the Romanists  
 whereon mass is celebrated. The city of Colo-  
 gne was famous for its relics. Many precious  
 relics were also discovered and exposed to ridi-

cule in England, upon abolition of the monasteries; such as the parings of St. Edmund's toes, the girdle of the Virgin Mary, &c. The honoring the relics of saints, on which the church of Rome afterwards founded the superstitious and lucrative use of them, as objects of devotion, as a kind of charms or amulets, principally appears to have originated in the very ancient custom of assembling at the cemeteries or burying-places of the Christian martyrs, for the purpose of commemorating them, and of performing divine worship. The practice of depositing relics of saints and martyrs under the altars in churches, was at last thought of such importance, that St. Ambrose would not consecrate a church because it had no relics; and the council of Constantinople in Trullo ordained, that those altars should be demolished under which there were found no relics. The rage for procuring relics for this and similar purposes became so excessive that, in A. D. 300, Theodosius the Great was obliged to pass a law, forbidding the people to dig up the bodies of the martyrs, and to traffic in their relics. Such was the origin of that respect for sacred relics which was afterwards perverted, and became the occasion of innumerable processions, pilgrimages, &c. In the end of the ninth century, it was not sufficient to reverence departed saints, and to confide in their intercessions and succours, to believe them endued with a power of healing diseases, working miracles, and delivering from all sorts of calamities and dangers; their bones, their clothes, the apparel and furniture they had possessed during their lives, the very ground which they had touched, or in which their carcases were laid, were treated with veneration, and supposed to retain the virtue of healing disorders both of body and mind, and of defending such as possessed them against the assaults and devices of the devil. In consequence of this, a new and lucrative trade was opened both in Europe and in the east. Public credulity was imposed upon, and relics of saints were multiplied without number; while the Greeks found a rich prey in the superstition of the Latin relic-hunters. The Roman Catholics in Great Britain do not acknowledge any worship to be due to relics, but merely a high veneration and respect, by which means they profess to honor God, who, they say, has often wrought very extraordinary miracles by them. Relics are forbidden to be used or brought into England by several statutes; and justices of peace are empowered to search houses for popish relics, which, when found, are to be defaced and burnt, &c.

**RELICT**, *n. s.* Old Fr. *relicte*; Lat. *relicta*. A widow; a wife desolate by the death of her husband.

If the fathers and husbands were of the household of faith, then certainly their *relicts* and children cannot be strangers in this household.

*Chaste relict!*

Honoured on earth, and worthy of the love  
Of such a spouse as now resides above. *Garth.*

**RELIEF** (Relevamen; in Domesday, Relevatio, Relevium), signifies a certain sum of money,

which the tenant holding by knight's service, grand serjeantry, or other tenure (for which homage or legal service is due), and being at full age at the death of his ancestor, paid unto his entrance.

**RELIEF, CHURCH OF, OR RELIEF, PRESBYTERY** OF, a set of Presbyterians, in Scotland, who differ from the established church only as to the submission to the law of patronage. See **ADVOWSON, PATRONAGE, AND PRESENTATION**. Many violent settlements, as they are called, of unpopular clergymen in various parishes in Scotland, had repeatedly taken place, in consequence of the rigorous exercise of the law of patronage, which was always a very unpopular measure among strict Presbyterians; and some of these presentees had been so exceedingly unpopular that they were obliged to be settled in their churches and benefices by the force of military power. Grievances of this kind had repeatedly taken place, and been often complained of, before any attempt was made for relief from them, till 1752; when the Rev. Mr. Thomas Gillespie, minister of Garnock, in Fifeshire, was deposed by the General Assembly of the Church of Scotland, and for no other fault, but merely, from a scruple of conscience, refusing to have any hand in a violent settlement of this kind, where the presentee was to be settled in opposition to the inclination of the parishioners. This disobedience to the supreme ecclesiastical court was punished with a formal and solemn deposition. Mr. Gillespie was soon after joined in communion by Mr. Thomas Boston of Jedburgh, and several other clergymen of the Church of Scotland, particularly the Rev. James Baine, minister of Paisley, who was settled in a relief church of Edinburgh; all of whom differed from the established church in nothing but the rigorous exercise of the law of patronage, which the church holds to be lawful and expedient, and their opponents to be highly criminal. On this principle these dissenting clergymen constituted themselves into a society, with Presbyterian powers, under the name of the Presbytery of Relief; and being soon followed by great numbers of people, who considered patronage as a piece of unjustifiable ecclesiastical, or rather civil tyranny, imposed on the church of Scotland by a tory party in the reign of queen Anne, merely to be avenged of the Presbyterian Whigs for their zeal against the house of Stuart; they, in a few years, erected churches of Relief (meaning thereby relief from the oppression of patronage) in a great number of parishes throughout Scotland. For farther particulars respecting this sect, we refer the reader to a treatise entitled *Historical Sketches of the Church*, published in 1774, by the Rev. James Smith, who succeeded Mr. Gillespie in the Relief Church at Dunfermline, but who afterwards returned to the established church, and died minister of a chapel in connexion with the establishment in Dundee.

**RELIEVE**, *v. a.* } Fr. *relief, reliever*; Span.  
**RELIEVABLE**, *adj.* } *relievar*; Ital. *relievo*; Lat.  
**RELIEF**, *n. s.* } *relevo*. To raise up; re-  
**RELIEVER**, *n. s.* } vive; support; succor;  
**RELIEVO**. } ease; free from pain, or  
painful duty; hence change a military guard; to

right legally; recommend or set off by interposition: the adjective and noun substantives corresponding: relieve is (from the Italian) the prominence of a figure or picture.

For this *relief*, much thanks; 'tis bitter cold,  
And I am sick at heart. *Shakespeare. Hamlet.*

Honest soldier, who hath *relieved* you?  
—Bernardo has my place. Give you good night.

*Shakespeare.*

Thoughts in my unquiet breast are risen,

Tending to some *relief* of our extremes. *Milton.*

Neither can they, as to reparation, hold plea of things, wherein the party is *relievable* by common law.

*Hale.*

Parallels, or like relations, alternately *relieve* each other; when neither will pass asunder, yet are they plausible together. *Browne.*

He found his designed present would be a *relief*, and then he thought it an impertinence to consider what it could be called besides. *Fell.*

So should we make our death a glad *relief*

From future shame. *Dryden's Knight's Tale.*

A convex mirror makes the objects in the middle come out from the superficies: the painter must do so in respect of the lights and shadows of his figures, to give them more *relievo* and more strength.

*Dryden.*

From thy growing store

Now lend assistance, and *relieve* the poor;

A pittance of thy land will set him free. *Id.*

*Relieve* the sentries that have watched all night. *Id.*

As the great lamp of day,

Through different regions does his course pursue,

And leaves one world but to revive a new;

While, by a pleasing change, the queen of night  
*Relieves* his lustre with a milder light. *Stepney.*

The figures of many ancient coins rise up in a much more beautiful *relief* than those on the modern; and the face sinking by degrees in the several declensions of the empire, till about Constantine's time, it lies almost even with the surface of the medal.

*Addison.*

Since the inculcating precept upon precept will prove tiresome, the poet must not encumber his poem with too much business; but sometimes *relieve* the subject with a moral reflection. *Id.*

He is the protector of his weakness, and the *reliever* of his wants. *Rogers's Sermon.*

Not with such majesty, such bold *relief*,

The forms august of kings, or conquering chief,

E'er swelled on marble, as in verse have shined,

In polished verse, the manners, and the mind. *Pope.*

To **RELIEVE THE SENTRIES** is to put fresh men upon that duty from the guard, which is generally done every two hours, by a corporal who attends the relief; to see that the proper orders are delivered to the soldier who relieves.

To **RELIEVE THE TRENCHES** is to relieve the guard of the trenches, by appointing those for that duty who have been there before.

**RELIEVO**, or **RELIEF**, in sculpture, &c., is the projecture of a figure from the ground or plane on which it is formed; whether that figure be cut with the chisel, moulded, or cast. There are three kinds or degrees of relievo, viz. alto, basso, and demi-relievo. The alto relievo, called also haut-relief, or high relievo, is when the figure is formed after nature, and projects as much as the life. Basso relievo, bass-relief, or low relievo, is when the work is raised a little from the ground, as in medals, and the frontis-

pieces of buildings; and particularly in the histories, festoons, foliages, and other ornaments of friezes. Demi relievo is when one half of the figure rises from the plane. When, in a basso-relievo, there are parts that stand clear out, detached from the rest, the work is called a demi-basso. In architecture, the relievo of the ornaments ought always to be proportioned to the magnitude of the building it adorns, and to the distance at which it is to be viewed.

**RELIEVO**, or **RELIEF**, in painting, is the degree of boldness with which the figures seem, at a due distance, to stand out from the ground of the painting. The relievo depends much upon the depth of the shadow, and the strength of the light; or on the height of the different colors, bordering upon one another; and particularly on the difference of the color of the figure from that of the ground; thus, when the light is so disposed as to make the nearest part of the figure advance, and is well diffused on the masses, yet insensibly diminishing, and terminating in a large spacious shadow, brought off insensibly, the relievo is said to be bold, and the clair obscure well understood.

**RELIGHT**, *v. a.* Re and light. To light anew.

His power can heal me, and *relight* my eye. *Pope.*

**RELIG'ION**, *n. s.* } *Fr. religion; Lat*

**RELIG'IOUS**, *adj. & n. s.* } *religio. See below.*

**RELIG'IOUSLY**, *adv.* } *Virtue, as founded*

upon piety and the expectation of future rewards and punishments; a system of revealed faith and worship: a religionist, a bigot; a religious person: the adjective and adverb corresponding in sense with religion: religious is also used for exact; strict: and, as a noun substantive, for a man professedly devoted to religion.

It is a matter of sound consequence, that all duties are by so much the better performed, by how much the men are more *religious*, from whose abilities the same proceed. *Hooker.*

When holy and devout *religious* christians  
Are at their beads, 'tis hard to draw them from  
thence;

So sweet is zealous contemplation! *Shakespeare.*

These are their brethren whom you Goths behold

Alive and dead, and for their brethren slain

*Religiously* they ask a sacrifice. *Id.*

The privileges, justly due to the members of the two houses and their attendants, are *religiously* to be maintained. *Bacon.*

For, who will have his work his wished end to win,

Let him with hearty prayer *religiously* begin.

*Drayton.*

He that is void of fear, may soon be just,

And no *religion* binds men to be traitors.

*Ben Jonson.*

He God doth late and early pray,

More of his grace than gifts to lend;

And entertains the harmless day

With a *religious* book or friend. *Wotton.*

Certain fryars and *religious* men were moved with some zeal, to draw the people to the christian faith.

*Abbot.*

Equity in law is the same that spirit is in *religion*, what every one pleases to make it: sometimes they go according to conscience, sometimes according to law, sometimes according to the rule of court.

*Selden.*

By *religion*, I mean that general habit of reverence towards the divine nature, whereby we are enabled and inclined to worship and serve God after such a manner as we conceive most agreeable to his will, so as to procure his favour and blessing.

*Wilkins.*

One spake much of right and wrong,  
Of justice, of *religion*, truth, and peace  
And judgment from above.

*Milton.*

Their lives

*Religious* titled them the sons of God. *Id.*

The christian *religion*, rightly understood, is the deepest and choicest piece of philosophy that is.

*More.*

If we consider it as directed against God, it is a breach of *religion*; if as to men, it is an offence against morality.

*South.*

France has vast numbers of ecclesiasticks, secular and *religious*.

*Addison's State of the War.*

What the protestants would call a fanatick is in the Roman church a *religious* of such an order; as an English merchant in Lisbon, after some great disappointments in the world, resolved to turn capuchin.

*Addison.*

By her informed, we best *religion* learn,  
Its glorious object by her aid discern. *Blackmore.*

The lawfulness of taking oaths may be revealed to the quakers, who then will stand upon as good a foot for preferment as any other subject; under such a motley administration, what pullings and hawlings, what a zeal and bias there will be in each *religionist* to advance his own tribe, and depress the others.

*Swift.*

*Religion* or virtue, in a large sense, includes duty to God and our neighbour; but, in a proper sense, virtue signifies duty towards men, and *religion* duty to God.

*Watts.*

Her family has the same regulation as a *religious* house, and all its orders tend to the support of a constant regular devotion.

*Law.*

But I am staggered when I consider that a case may happen in which the established *religion* may be the *religion* of a minority of the people, that minority, at the same time, possessing a majority of the property, out of which the ministers of the establishment are to be paid.

*Bp. Watson.*

**RELIGION.** Religion is, according to Cicero, derived from *relegere*, to reconsider; but according to Servius, and most modern grammarians, from *religare*, to bind fast. The reason assigned by the Roman orator for deducing the term from *relego* is given in these words, 'qui autem omnia, quæ ad cultum deorum pertinent, diligenter retractarent, et tanquam relegerent, sunt dicti religiosi ex relegendo.' The reason given by Servius for his derivation of the word is 'quod mentem religio religet.' If Cicero's etymology be the true one, the word religion will denote the diligent study of whatever pertains to the worship of the gods; but according to the other derivation, which we prefer, it denotes that obligation which we feel on our minds from the relation in which we stand to some superior power. Religion is sometimes distinguished from theology, in that the former chiefly regards a number of practical duties, and the latter a system of doctrinal truths. But theology, fully considered, embraces both doctrine and practice. Mankind are distinguished from the brutal tribes, and elevated to a higher rank, by the rational and moral faculties with which they are endowed; but they are still more widely distin-

guished from the inferior creation, and more highly exalted above them, by being made capable of religious notions and sentiments. The slightest knowledge of history is sufficient to inform us that religion has ever had a powerful influence in moulding the sentiments and manners of men. It has sometimes dignified, and sometimes degraded, the human character. In one region or age it has been favorable to civilisation and refinement; in another it has occasionally cramped the genius, depraved the minds, and deformed the morals of men. The varieties of religion in this general view of the term are almost innumerable; and the members of every distinct sect must view all who differ from them as more or less mistaken with respect to the most important concerns of man: wherever, however, human society consists, we are certain of finding religious opinions and sentiments. The great variety of religions that have been established among mankind may be reduced to four classes, viz. the Jewish, the Christian, the Pagan, and the Mahometan.

The first two claim our attention as the great divisions of Revealed Theology. See THEOLOGY. The last two are treated of in this work under the articles POLYTHEISM and MAHOMETANISM.

**RELINQUISH**, *v. a.* } Lat. *relinquo*. To  
**RELINQUISHMENT**, *n. s.* } forsake; abandon;  
leave; desert: the noun substantive corresponding.

Government or ceremonies, or whatsoever it be which is popish, away with it: this is the thing they require in us, the utter *relinquishment* of all things popish.

*Hooker.*

The English colonies grew poor and weak, though the English lords grew rich and mighty; for they placed Irish tenants upon the lands *relinquished* by the English.

*Davies.*

The habitation there was utterly *relinquished*.

*Abbot.*

The ground of God's sole property in any thing is, the return of it made by man to God; by which act he *relinquishes* and delivers back to God all his right to the use of that thing, which before had been freely granted him by God.

*South's Sermons.*

That natural tenderness of conscience which must first create in the soul a sense of sin, and from thence produce a sorrow for it, and at length cause a *relinquishment* of it, is took away by a customary repeated course of sinning.

*South.*

**RELISH**, *n. s., v. a., &* } Fr. *relecher*, to lick  
**RELISHABLE**. [ *v. n.* } again. Minsheu and  
Skinner. Taste; the effect of any thing on the palate; used particularly of a pleasing taste; liking; delight; sense: to relish is, to give a taste; to taste; have a liking; have a pleasing taste or flavor; give pleasure.

The king-becoming graces  
As justice, verity, temperance, stablesness,  
Devotion, patience, courage, fortitude;

I have no *relish* of them. *Shakspeare. Macbeth*

I love the people;

Though it do well, I do not *relish* well

Their loud applause. *Shakspeare.*

Had I been the funder-out of this secret, it would not have *relied* among my other discredits. *Id.*

The ivory feet of tables were carved into the shape of lions, without which, their greatest dainties would not *relish* to their palates.

*Hakewill on Providence.*

Much pleasure we have lost, while we abstained  
From this delightful fruit, nor known till now  
True *relish*, tasting. *Milton.*

How will dissenting brethren *relish* it ?

What will malignants say ? *Hudibras.*  
Under sharp, sweet, and sour, are abundance of  
immediate peculiar *relishes* or tastes, which expe-  
rienced palates can easily discern. *Boyle on Colours.*

On smoking lard they dine ;  
A sav'ry bit that served to *relish* wine. *Dryden.*  
Could we suppose their *relishes* as different there as  
here, yet the manna in heaven suits every palate.

*Locke.*  
We have such a *relish* for faction, as to have lost  
that of wit. *Addison's Freeholder.*  
Some hidden seeds of goodness and knowledge  
give him a *relish* of such reflections as improve the  
mind, and make the heart better. *Addison.*

When liberty is gone,  
Life grows insipid, and has lost its *relish*. *Id.*  
A theory which, how much soever it may *relish* of  
wit and invention, hath no foundation in nature.

*Woodward.*  
He knows how to prize his advantages, and *relish*  
the honours which he enjoys. *Atterbury.*  
It preserves some *relish* of old writing. *Pope.*  
The pleasure of the proprietor, to whom things be-  
come familiar, depends, in a great measure, upon  
the *relish* of the spectator. *Seed.*

You are to nourish your spirit with pious readings,  
and holy meditations, with watching, fastings, and  
prayers, that you may taste, and *relish*, and desire  
that eternal state which is to begin when this life  
ends. *Law.*  
Men of nice palates would not *relish* Aristotle, as  
dress up by the schoolmen. *Baker.*

RELIVE', *v. n.* Re and live. To revive; to  
live anew. Not used.  
The thing on earth, which is of most avail,  
Any virtue's branch and beauty's bud,  
*Reliven* not from any good. *Spenser.*

RELOVE', *v. a.* Re and love. To love in  
return. Not used.  
To own for him so familiar and levelling an af-  
fection as love, much more to expect to be *relieved* by  
him, were not the least saucy presumption man could  
be guilty of, did not his own commandments make it  
a duty. *Boyle.*

RELUC'CENT, *adj.* Lat. *relucens*. Shining ;  
transparent ; pellucid.  
In brighter mazes, the *relucens* stream  
Plays o'er the mead. *Thomson's Summer.*

RELUCT', *v. a.* Latin *reluctor*. To  
struggle again or hard-  
RELUCT'ANCE, or }  
RELUCT'ANCY, *n. s.* } ly : the noun-substan-  
RELUCT'ANT, *adj.* } tive means repugnance ;  
RELUCT'ATE, *v. n.* } resistance ; unwilling-  
RELUCT'ATION, *n. s.* } ness : reluctant ; unwill-  
ing : reluctate, to resist ; struggle against.

The king prevailed with the prince, though not  
without some *reluctation*. *Bacon's Henry VII.*  
Adam's sin, or the curse upon it, did not deprive  
him of his rule, but left the creatures to a rebellion  
or *reluctation*. *Bacon.*

We, with studied mixtures, force our *relucting*  
appetites, and, with all the spells of epicurism, con-  
jure them up, that we may lay them again.

*Decay of Piety.*  
In violation of God's patrimony, the first sacrilege  
is looked upon with some horror, and men devise  
colours to delude their *reluctating* consciences ; but,  
when they have once made the breach, their scrupu-  
losity soon retires. *Id.*

It savours

*Reluctance* against God, and his just yoke  
Laid on our necks. *Milton.*

*Reluctant* ; but in vain ! a greater power  
Now ruled him. *Id. Paradise Lost.*

A little more weight added to the lower of the  
marbles, is able to surmount their *reluctancy* to sepa-  
ration, notwithstanding the supposed danger of  
thereby introducing a vacuum. *Boyle.*

Bear witness, heaven, with what *reluctancy*  
Her helpless innocence I doom to die. *Dryden.*  
Many hard stages of discipline must he pass  
through, before he can subdue the *reluctances* of his  
corruption. *Rogers.*

How few would be at the pains of acquiring such  
an habit, and of conquering all the *reluctancies* and  
difficulties that lay in the way towards virtue.  
*Atterbury.*

Some refuge in the muse's art I found ;  
*Reluctant* now I touched the trembling string,  
Bereft of him who taught me how to sing. *Tickel.*

If therefore you find in yourself a secret disincli-  
nation to any particular action or duty, and the mind  
begins to cast about for excuses and reasons to jus-  
tify the neglect of it,—consider the matter well : go  
to the bottom of that *reluctance* ; and search out  
what it is that gives the mind this aversion to it.  
*Mason.*

RELUME', *v. a.* } To light anew ; rekin-  
RELUMINE. } dle.

Once put out thy light ;  
I know not where is that Promethean heat,  
That can thy light *relumine*. *Shakspeare. Othello.*  
*Relumine* her ancient light, nor kindle new. *Pope.*

RELY', *v. n.* } Re and lie. To lean  
REL'ANCE, *n. s.* } upon with confidence ; put  
trust in ; depend upon ; with on ; the noun-sub-  
stantive corresponding.

His days and times are past,  
And my *reliance* on his fracted dates  
Has smit my credit. *Shakspeare. Timon.*  
Thus Solon to Pisistratus replied,  
Demanded, on what succour he *relied*,  
When with so few he boldly did engage ?  
He said he took his courage from his age. *Denham.*

Go in thy native innocence ! *rely*  
On what thou hast of virtue ; summon all !  
For God towards thee has done his part, do thine. *Milton.*

Egypt does not on the clouds *rely*,  
But to the Nile owes more than to the sky. *Waller.*  
Fear *relies* upon a natural love of ourselves, and is  
complicated with a necessary desire of our own pre-  
servation. *Tillotson.*

Such variety of arguments only distract the under-  
standing that *relies* on them. *Locke.*

Though reason is not to be *relied upon* as univer-  
sally sufficient to direct us what to do ; yet it is ge-  
nerally to be *relied upon* and obeyed, where it tells  
us what we are not to do. *South.*

That pellucid gelatinous substance, which he  
pitches upon with so great *reliance* and positiveness,  
is chiefly of animal constitution. *Woodward.*

They afforded a sufficient conviction of this truth,  
and a firm *reliance* on the promises contained in it.  
*Rogers.*

No prince can ever *rely* on the fidelity of that man  
who is a rebel to his Creator. *Id.*

The pope was become a party in the cause, and  
could not be *relied upon* for a decision. *Atterbury.*

Resignation in death, and *reliance* on the divine  
mercies, give comfort to the friends of the dying.  
*Clarissa.*



**REMAIN'**, *v. n., v. a. & n. s.* } Lat. *remaneo*.  
**REMAINDER**, *adj. & n. s.* } To be left out  
of a larger quantity or number; continue; not  
to be comprised: to await; be left to: as a noun-  
substantive, relic; memento; the body as left  
by the soul (generally used in the plural): re-  
mainder, refuse left; that which is left; reman-  
nant: in law, the last chance of inheritance.

Bake that which ye will bake to-day; and that  
which *remaineth* over lay up until the morning.

*E.rodus xvi. 23.*

That that *remains* shall be buried in death.

*Job xxvii. 15.*

If what you have heard shall *remain* in you, ye  
shall continue in the Son. *1 John ii. 24.*

Such end had the kid; for he would weaned be  
Of craft, coloured with simplicity;  
And such end, pardie, does all them *remain*  
That of such falsers friendship shall be fain.

*Spenser.*

Now somewhat sing, whose endless souvenance  
Among the shepherds may for aye *remain*. *Id.*

A most miraculous work in this good king,  
Which often since my here *remain* in England,  
I've seen him do. *Shakspeare. Macbeth.*

His brain

Is as dry as the *remainder* basket

After a voyage. *Id. As You Like It.*

The gods protect you,

And bless the good *remainders* of the court!

*Shakspeare.*

Shew us

The poor *remainder* of Andronicus. *Id.*

A fine is levied to grant a reversion or *remainder*,  
expectant upon a lease that yieldeth no rent.

*Bacon.*

It may well employ the *remainder* of their lives to  
perform it to purpose, I mean the work of evangeli-  
cal obedience. *Hammond.*

Mahomet's crescent by our feuds encrease,  
Blasted the learned *remainders* of the East.

*Denham.*

The easier conquest now

*Remains* thee, aided by this host of friends,

Back on thy foes more glorious to return. *Milton.*

He for the time *remained* stupidly good. *Id.*

Childless thou art, childless *remain*. *Id.*

There are two restraints which God hath put upon  
human nature, shame and fear; shame is the weaker,  
and hath place only in those in whom there are some  
*remainders* of virtue. *Tillotson.*

What madness moves you, matrons to destroy  
The last *remainders* of unhappy Troy! *Dryden.*

That a father may have some power over his chil-  
dren is easily granted; but that an elder brother has  
so over his brethren *remains* to be proved. *Locke.*

Could bare ingratitude have made any one so  
diabolical, had not cruelty come in as a second to  
its assistance, and cleared the villain's breast of all  
*remainders* of humanity! *South.*

If he, to whom ten talents were committed, has  
squandered away five, he is concerned to make a  
double improvement of the *remainder*. *Rogers.*

If these decoctions be repeated till the water comes  
off clear, the *remainder* yields no salt. *Arbuthnot.*

I grieve with the old, for so many additional in-  
conveniences, more than their small *remain* of life  
seemed destined to undergo. *Pope.*

But fowls obscene dismembered his *remains*,

And dogs had torn him. *Id. Odyssey.*

Of six millions raised every year, for the service of  
the publick, one third is intercepted through the  
several subordinations of artful men in office, before  
the *remainder* is applied to the proper use. *Swift.*

**REMAINDER**, in law, is an estate limited in  
lands, tenements, or rents, to be enjoyed after  
the expiration of another particular estate. As  
if a man seised in fee simple grants lands  
to A for twenty years, and, after the determina-  
tion of the said term, then to B and his heirs for  
ever: here the former is tenant for years, re-  
mainder to the latter in fee. In the first place,  
an estate for years is created out of the fee, and  
given to A, and the residue and the remainder  
of it is given to B. Both their interests are in  
fact only one estate; the present term of years,  
and the remainder afterwards, when added to-  
gether, being equal only to one estate in fee.  
Blackstone.

The word remainder is no term of art, nor is it  
necessary in passing a remainder. Any words  
sufficient to show the intent of the party, will  
create a remainder; because such estates take  
their denomination of remainder from the man-  
ner of their existence after they are limited. See  
Ferne on Remainders.

There is this difference between a remainder  
and a reversion: in case of a reversion the estate  
granted, after the limited time, reverts to the  
grantor or his heirs; but by a remainder it goes  
to some third person, or a stranger.

## REMAINS (ORGANIC).

**REMAINS, ORGANIC.** One of the first observa-  
tions which were made after the distinction of  
rocky masses, in reference to their component  
parts, was the almost invariable order of relative  
position which the different species maintain with  
respect to each other. Different rocks are seen  
piled upon one another in mountain ranges; and,  
in digging into the depths of the earth, a perpetual  
and varying succession of strata is discovered.  
But no change of place has been found between  
the upper and lower orders of the series. The  
lines of junction of the different species, and the  
strata into which they are individually divided,  
are parallel to one another. From hence the  
conclusion seems striking; first, that their com-

ponent parts must formerly have been in a state  
of fluidity; and, secondly, that the lower rocks  
in position must have been the first in formation.  
Their division, therefore, into two grand classes,  
distinguished no less by their relative position  
than by the obvious characters of their composi-  
tion, is scientific. A crystalline texture, and the  
absence of extraneous fossils, mark the series  
which is lowest in position, and justify the name  
of primordial; while the earthy composition of  
the higher series, and the different bodies which  
they envelope, from fragments of the preceding  
class to remains of organised bodies, authorise  
no less for these the appellation of secondary.  
Both these divisions of rocks are traversed by

fissures which are filled with matters wholly foreign to their constitution. These veins are allowed by all to be of posterior formation to the masses between which they are interposed. Sometimes veins of different substances cut through each other, and in this case it is obvious that the one which is cut must have been of older formation than the one which traverses it. The disorder and various degrees of inclination of the planes of the strata point to some great revolution which must have broken their surfaces by the elevation of the upper or the depression of the lower ridge. Geologists all agree in this unavoidable inference, though they differ from each other as to the nature of the cause.

In the science of geology, of late, observation has certainly greatly superseded useless speculation, and the classification of the different formations of the earth's surface, the distinction and description of different individuals of a series, the analysis of minerals, and the investigation of their properties, have taken the place of useless cavils about remoter causes. It is by such gradual means that we may hope to penetrate the secrets of time; step by step to unravel the long series of past events; to harmonise philosophy with history.

There is not a more interesting or important department of this science than that which involves the consideration of organic remains; varying as much in regard to the state in which they are found as in their respective species. Sometimes the most delicate bodies are little changed by the processes which they have undergone; sometimes they are completely impregnated with stony matter; and often exhibit mere casts of the original substance. Uniting perhaps in himself more extensive knowledge of every department of nature than any other existing individual, it has been the arduous undertaking of M. Cuvier not only to class the different species, and compare them with their existing analogues, but carefully to ascertain the superpositions of the strata in which their remains occur, and their connexion with the different animals and plants which they enclose.

He has particularly illustrated the fossil remains of quadrupeds; and the highest degree of importance attaches to this class of fossils. They indicate more clearly than others the nature of the revolutions they have undergone. The important fact of the repeated irruptions of the sea upon the land is by them placed beyond a doubt. The remains of shells and of other bodies of marine origin might merely indicate that the sea had once existed where these collections are found. Thousands of aquatic animals may have been left dry by a recess of the waves, while their races may have been preserved in more peaceful parts of the ocean. But a change in the bed of the sea, and a general irruption of its waters, must have destroyed all the quadrupeds within the reach of its influence. Thus entire classes of animals, or at least many species, must have been utterly destroyed. Whether this actually has been the case we are more easily able to determine from the greater precision of our knowledge with respect to the quadrupeds, and the smaller limits of their number. It may be decided at

VOL. XVIII.

once whether fossil bones belong to any species which still exists, or to one that is lost; but it is impossible to say whether fossil testaceous animals, although unknown to the zoologist, may not belong to genera yet undiscovered in the fathomless depths of the sea.

This indefatigable observer of nature, from a mature consideration of the subject, after a display of the most complete knowledge of the osteology of comparative anatomy, and after a learned comparison of the description of the rare animals of the ancients, and the fabulous products of their imaginations, draws the following instructive conclusion:—'None of the larger species of quadrupeds, whose remains are now found imbedded in regular rocky strata, are at all similar to any of the known living species. This circumstance is by no means the mere effect of chance, or because the species to which these fossil bones have belonged are still concealed in the desert and uninhabited parts of the world, and have hitherto escaped the observation of travellers, but this astonishing phenomenon has proceeded from general causes, and the careful investigation of it affords one of the best means for discovering and investigating the nature of those causes.'

The method of observation adopted is susceptible, he contends, of the utmost accuracy. 'Every organised individual forms an entire system of its own, all the parts of which mutually correspond and concur to produce a certain definite purpose by reciprocal re-action, or by combining towards the same end. Hence none of these separate parts can change their forms without a corresponding change on the other parts of the same animal, and consequently each of these parts taken separately indicates all the other parts to which it has belonged. Thus, if the viscera of an animal are so organised as only to be fitted for the digestion of recent flesh, it is also requisite that the jaws should be so constructed as to fit them for devouring their prey; the claws must be constructed for seizing and tearing it to pieces; the teeth for cutting and dividing its flesh; the entire system of the limbs, or organs of motion, for pursuing and overtaking it; and the organs of sense for discovering it at a distance. Hence any one who observes merely the print of a cloven foot, may conclude that it has been left by a ruminant animal; and regard the conclusion as equally certain with any other in physics or in morals. Consequently, this single foot-mark clearly indicates to the observer the forms of the teeth, of the jaws, of the vertebræ, of all the leg bones, thighs, shoulders, and of the trunk of the body of the animal that left the mark.'

It is from this connexion of all the different parts of an animal that the smallest piece of bone may become the sure index of the class and species of the animal to which it has belonged; and it is from an indefatigable and ingenious application of this rule that our author has been enabled to class the fossil remains of seventy-eight different quadrupeds, of which forty-nine are distinct species, hitherto unknown to naturalists. The bones are generally dispersed, seldom occurring in complete skeletons, and

2 I

still more rarely is the fleshy part of the animal preserved.

But one of the most important and interesting of the observations for which we are indebted to the precision of the French naturalist is the distinction of two different formations amongst secondary strata. These consist of alternate deposits from salt and fresh water; and are characterised by the nature of the shells which are found imbedded in them. The country about Paris is founded upon chalk. This is covered with clay and a coarse limestone, containing marine petrifications. Over this lies an alternating series of gypsum and clay, in which occur the remains of quadrupeds, birds, fish, and shells, all of land or fresh water species. Above this interesting stratum lie marl and sandstone, containing marine shells, which are covered with beds of limestone and flint, which again contain petrifications of fresh water remains. The upper bed of all is of an alluvial nature, in which trunks of trees, bones of elephants, oxen, and rein-deer, intermingled with salt water productions, seem to suggest that both salt and fresh water have contributed to its accumulation. This alternate flux and reflux of the two fluids is a most extraordinary phenomenon, and promises to lead to an important conclusion respecting the general theory of the earth. We are inclined to think that something analogous to the process which produced these changes may be perceived in operations which are going on in our own time, and in gradual alterations which have been effected within the memory of one generation.

The following extract from the accurate descriptions of the indefatigable De Luc will better explain our ideas. We have selected one from among many instances which are afforded by an attentive examination of our own coasts. 'Slapton Lee occupies the lower part of a combe, which at first formed a recess in the bay, but, the sea before it being shallow, the waves brought up the gravel from the bottom along the coast, and the beach thus produced passed at length quite across this recess, which it closed: since then, the fresh water proceeding from the combe has almost entirely displaced the salt water within this space, because the former arriving there freely, and passing through the gravel of the beach, repels the small quantity of the sea water which filtrates into it. Slapton Lee, which is about two miles in length and a quarter of a mile in its greatest breadth, is a little brackish, on account of its communications with the sea water, as well through the gravel in common seasons, as when there is any opening in the beach; however, it contains fresh water fish, carp, tench, and pike. The sediments of the land waters are tending to fill up this basis, and wherever the bottom is sufficiently raised the reeds are beginning to grow.'

Such may have been the process which formed a fresh water deposit upon a marine basis. By extending the analogy further, we can have little difficulty in conceiving that the barrier thus raised by the action of the waves may have been easily destroyed again, even by an extraordinary exertion of the same power which raised it, or by some other of those violent revolutions whose

effects are marked upon the face of the whole earth. Thus a way was opened for the return of the waters of the ocean, which again deposited their sediments and the remains of their living tribes, and thus gave rise to the upper salt water strata. The same causes again acting excluded once more the waves of the sea, and gave time for the deposit of the upper fresh water formation. Such an explanation appears to us simple and satisfactory. It accounts for the phenomena of nature by nature's laws. But, however this may be, the sagacity which first pointed out the distinction cannot be too much praised. The discovery has already stimulated the exertions of others, and there is reason to suppose that the phenomenon is not only not confined to the environs of Paris, but is of pretty general occurrence in secondary countries. A similar formation has been observed in the Isle of Wight; and has been most scientifically described and compared with the French strata by a member of the Geological Society.

It is remarkable that those coarse limestone strata which are chiefly employed at Paris for building, are the last formed series which indicate a long and quiet continuance of the water of the sea above the surface of the continent. About them indeed there are found formations containing abundance of shells and other productions of the sea, but these consist of alluvial materials, sand, marl, sand-stone, or clay, which rather indicate transportations that have taken place with some degree of violence than strata formed by quiet depositions; and, where some regular rocky strata of inconsiderable extent and thickness appear above or below these alluvial formations, they generally bear the marks of having been deposited from fresh water. All the known specimens of the bones of viviparous land quadrupeds have either been found in these formations from fresh water, or in the alluvial formations; whence there is every reason to conclude that these animals have only begun to exist, or at least to leave their remains in the strata of our earth since that retreat of the sea which was next before its last irruption. It has also been clearly ascertained, from an attentive consideration of the relation of the different remains with the strata in which they have been discovered, that oviparous quadrupeds are found in much older strata than those of the viviparous class. Some of the former have been observed in and even beneath the chalk. Dry land and fresh waters must therefore have existed before the foundation of the chalk strata. No bones of mammiferous quadrupeds are to be found till we come to the newer formations, which lie over the coarse limestone strata incumbent on the chalk. Determinate order may also be observed in the succession of these. The genera which are now unknown are the lowest in position: unknown species of known genera are next in succession: and lastly, the bones of species, apparently the same with those which are now in existence, are never found but in the latest alluvial depositions.

The more we learn respecting the secondary strata of the globe, the more interesting becomes the investigation. The bold outline of the pre-

native ranges, their cloud-capt summits and majestic forms, are calculated to rivet the attention; but they rather force the fancy to speculate upon their formation than lead the judgment by internal evidences to their origin. It is in the curious observations above recited that we seem to approach the history of our own state. The study of secondary formations is as yet scarcely commenced. The labors of Cuvier have thrown a new light upon their high importance; already by his exertions has the history of the most recent changes been ascertained, in one particular spot, as far as the chalk formation. This, which has hitherto been conceived to be of very modern origin, is shown to have owed its deposition to causes connected with the revolution and catastrophe before the last general irruption of the waters over our present habitable world. Our author well observes that these posterior geological facts, which have hitherto been neglected by geologists, furnish the only clue by which we may hope, in some measure, to dispel the darkness of the preceding times. 'It would certainly be exceedingly satisfactory to have the fossil organic productions arranged in chronological order, in the same manner as we now have the principal mineral substances. By this the science of organization itself would be improved; the development of animal life; the succession of its forms; the precise determinations of those which have been first called into existence, the simultaneous production of certain species and their gradual extinction;—all these would perhaps instruct us fully as much in the essence of organisation as all the experiments that we shall ever be able to make upon living animals: and man, to whom only a short space of time is allotted upon the earth, would have the glory of restoring the history of thousands of ages which preceded the existence of the race, and of thousands of animals which never were contemporaneous with his species.'

In the present state of science respecting them we cannot, we conceive, assist the geological student better than by presenting to him an ample classification of existing organic remains. We depend in the first instance largely on the abstract of Cuvier's researches furnished in the notes of Mr. Jameson to M. Kerr's translation of the Essay on the Earth:

#### CLASS I.—MAMMALIA.

##### Order I.—DIGITATA.

##### Family.—*Glires*.

*Cavia*.—The slaty limestone of Oeningen, near Schaffhausen, affords remains of a species of this genus. Cuvier conjectures it to belong to the *cavia porcellus* or Guinea pig, or more likely to an unknown species of this tribe, or of that entitled *arvicola*.

*Mus, mouse*.—In the slaty limestone rocks at Walsch, in the circle of Saatz, Bohemia, there are fossil remains of a species of this tribe nearly allied to the *mus terrestris*; smaller remains occur in alluvial strata at Kostritz, in Germany, and in the limestone of Corsica.

*Lagomys*.—Occurs in fissures of the third se-

condary limestone in the rock of Gibraltar and Corsica. It nearly resembles the *l. alpinus* of Siberia.

*Lepus, hare*.—Two species occur in fissures of the limestone rocks of Cette; one of them bears a strong resemblance to the common rabbit, the other is one-third less.

##### Family.—*Feræ*

*Ursus, bear*.—2. *U. Spelæus*.—The size of a horse, and different from any of the present existing species. 2. *U. Arctoideus*.—A smaller species, also extinct. Both species are fossil, and remains of them are found in great abundance in limestone caves in Germany and Hungary. The caves vary much in magnitude and form, and are more or less deeply incrustated with calcareous sinter, which assumes a great variety of singular and often beautiful forms. The bones occur nearly in the same state in all these caves: detached, broken, but never rolled; they are somewhat lighter and less compact than recent bones, but slightly decomposed, contain much gelatine, and are never mineralised. They are generally enveloped in an indurated earth, which contains animal matter; sometimes in a kind of alabaster or calcareous sinter, and by means of this mineral are sometimes attached to the walls of the caves. It is worthy of remark that these bones occur in an extent of upwards of 200 leagues.

Cuvier thinks that rather more than three-fourths of the bones in the caves of Gaylenreuth, Bavaria, belong to species of bears now extinct; one-half, or two-thirds of the remaining fourth belong to a species of hyæna, which occurs in a fossil state in other situations. A very small number of these remains belong to a species of the genus lion or tiger; and another to animals of the dog or wolf kinds; and, lastly, the smallest portion belongs to different species of smaller carnivorous animals, as the fox and pole-cat. Cuvier is inclined to conjecture that the animals to which they belonged must have lived and died peaceably on the spot where we now find them. This opinion is rendered highly probable from the nature of the earthy matter in which they are enveloped, and which, according to Laugier, contains an intermixture of animal matter with phosphate of lime, and probably also phosphate of iron. Remains of the fossil bear also occur in limestone caves in England.

*Canis, hyæna, and wolf*.—Several species occur in the caves already mentioned; one very closely resembles the Cape hyæna, and is about the size of a small brown bear; another species is allied to the dog or wolf; and a third species is almost identical with the common fox. A fossil species also resembling the common fox has been found in the gypsum quarries near Paris; and in the same formation there are fossil remains of a genus intermediate between *canis* and *viverra*. Remains of the wolf were found at Cannstadt in Germany, along with those of the elephant, rhinoceros, hyæna, horse, deer, and hare. In the alluvial deposits there are remains of the hyæna. Blumenbach has described the remains of a fossil hyæna, nearly resembling

the *canis crocuta*, which was found in marl along with the remains of the lion and the elephant, between Osterode and Herzberg in Hanover. Professor Buckland's account of the Kirkdale cave of hyænas will be found in our article GREAT BRITAIN, vol. x. p. 596.

Bones of hyænas have been found in similar caves in other parts of Great Britain, viz. at Crawly Rocks near Swansea, in the Mendip Hills at Clifton, at Wirksworth in Derbyshire, and at Oreston, near Plymouth. In some of these there is evidence of the bones having been introduced by beasts of prey; but in that of Hutton Hill, in the Mendips, which contains rolled stones, it is probable they were washed in.

*Felis, tiger*.—One species occurs in the limestone caves of Germany, and appears to be nearly allied to the jaguar; another species, nearly allied to the tiger, is found in alluvial soil along with fossil remains of the elephant, rhinoceros, hyæna, and mastodon.

*Viverra, weasel*.—Two species occur in the German limestone caves; the one is allied to the common pole-cat, and the other to the zorille, a pole-cat belonging to the cape of Good Hope. Another species allied to the ichneumon, but double its size, occurs in the gypsum quarries around Paris.

#### Family.—*Bruta*.

*Bradypus, sloth*.—Two fossil species have been described, which are nearly allied not only to the two living species, but also to the myrmecophaga, or ant eater. They are the following:—  
1. *Megalonix*.—This remarkable fossil animal appears to have been the size of an ox. Its remains were first discovered in limestone caves in Virginia in the year 1796.  
2. *Megatherium*.—This species is the size of the rhinoceros, and its fossil remains have hitherto been found only in South America. The first, and most complete skeleton, was sent from Buenos Ayres by the marquis Loretto, in the year 1789. It was found in digging an alluvial soil, on the banks of the river Luxan, a league south-east of the village of that name, about three leagues W. S. W. of Buenos Ayres. Plate I. fig. 1, REMAINS, ORGANIC, gives a faithful representation of this remarkable skeleton, which is now preserved in the Royal Cabinet of Madrid. A second skeleton of the same animal was sent to Madrid from Liua, in the year 1795; and a third was found in Paraguay. Thus it appears that the remains of this animal exist in the most distant parts of South America. It is very closely allied to the megalonix, and differs from it principally in size, being much larger. Cuvier is of opinion that the two species, the megalonix and megatherium, may be placed together, as members of the same genus, and should be placed between the sloths and ant-eaters, but nearer to the former than to the latter. It is worthy of remark that the remains of these animals have not been hitherto found in any other quarter of the globe besides America, the only existing country which affords them.

#### Order II.—*MARSUPIALIA*.

*Didelphis, opossum*.—One species of this extraordinary tribe has been found in a fossil state in the gypsum quarries near Paris. It does not

belong to any of the present existing species, and is therefore considered as extinct. Cuvier remarks that, as all the species of this genus are natives of America, it is evident that the hypothesis advanced by some naturalists, of all the fossil organic remains of quadrupeds having been flooded from Asia to northern countries, is erroneous.

#### Order III.—*SOLIDUNGULA*.

*Equus adamaticus, equus caballus*?—Fossil teeth of a species of horse are found in alluvial soils associated with those of the elephant, rhinoceros, hyæna, mastodon, and tiger? These teeth are larger than those of the present horse, and to all appearance belong to a different species which inhabited the countries where they are now found, as Great Britain, along with elephants, rhinoceroses, &c.

#### Order IV.—*BISULCA*.

*Cervus, deer*.—1. *Fossil elk of Ireland*.—This, the most celebrated of all the fossil ruminating animals, is certainly of a different species from any of those that at present live on the earth's surface, and may therefore be considered as extinct. It was first found in Ireland, where it generally occurs in shell marl and in peat-bogs. It has also been found in superficial alluvial soil in England, Germany, and France.

In plate I. fig. 2, we have given a drawing of the head and horns of this animal. It was dug out of a marl pit at Dardisdoun, near Drogheda, in Ireland. Dr. Molyneux, in the Philosophical Transactions, informs us that its dimensions were as follows:—

	Ft. In.
From the extreme tip of each horn . . . . . a. b.	10 10
From the tip of the right horn to its root . . . . . c. d.	5 2
From the tip of one of the inner branches to the tip of the opposite branch . . . . . e. f.	3 7½
The length of one of the palms, within the branches . . . . . g. h.	2 6
The breadth of the palm, within the branches . . . . . i. k.	1 10½
The length of the right brow antler . . . . . d. l.	1 2
The beam of each horn at some distance from the head, in diameter . . . . . m.	0 2½
in circumference, . . . . .	0 8
The beam of each horn, at its root, in circumference . . . . . d.	0 11
The length of the head, from the back of the skull to the extremity of the upper jaw, . . . . . n. o.	2 0
Breadth of the skull . . . . . p. q.	1 0

We saw a fine specimen of the horns of this animal in the summer of 1828 at Knole, the seat of the duke of Dorset. It is exalted among the trophies of the chase in the hall of his grace, but not claiming we suppose to have been hunted by a duke of Dorset. A splendid and nearly perfect skeleton of this animal has been lately dug out of a marl pit in the Isle of Man, and is now preserved in the Regium Museum of Edinburgh.

2. *Fossil deer of Scania*.—Found in a peat-

Fig. 1. SKELETON of the MEGATHERIUM  
Dug out of Alluvial Strata near Buenos Ayres



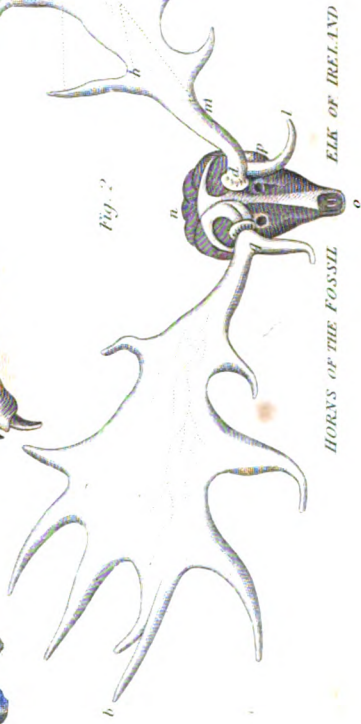
TOOTH of the GREAT MASTODON



TOOTH of the AMERICAN ELANDIA



Fig. 2.



HORNS of the FOSSIL ELK of IRELAND

London: Published by Thomas Agnew & Sons, (Theopside).



moss in Scania. It appears from the description of the horns to be an extinct, or at least, an unknown species.

3. *Fossil deer of Somme*.—The horns, the only parts hitherto discovered, show that this animal, although nearly allied to the fallow-deer, must have been much larger than the fallow-deer. The horns occur in loose sand in the valley of Somme in France, and in Germany.

4. *Fossil deer of Etampes*.—Allied to the reindeer, but much smaller, not exceeding the roe in size. The bones were found in abundance near Etampes in France, imbedded in sand.

5. *Fossil roe of Orleans*.—Found in the vicinity of Orleans. It occurs in limestone, along with bones of the palæotherium. It is the only instance known of the remains of a living species having been found along with those of extinct species. But Cuvier enquires, May not the bones belong to a species of roe, of which the distinctive characters lie in parts hitherto undiscovered?

6. *Fossil roe of Somme*.—Very nearly allied to the roe. Found in the peat of Somme.

7. *Fossil red deer or stag*.—Resembling the red deer or stag. Its horns are found in peat-bogs, or sand pits in Scotland, England, France, Germany, and Italy.

8. *Fossil fallow deer*.—Found in peat-bogs and sand pits in Scotland and France.

*Bos, ox*.—1. *Aurochs*.—Cuvier considers this as distinct from the common ox, and it differs from the present varieties in being larger. Skulls and horns of this species have been found in alluvial soil in England, Scotland, France, Germany, and America.

2. *Common ox*.—The skulls of this species also differ from those of the present existing races, in being larger, and the direction of the horns being different. They occur in alluvial soil in many different parts of Europe, and are considered by Cuvier as belonging to the original race of the present domestic ox.

3. *Large buffalo of Siberia*.—The skull of this animal is of great size, and appears to belong to a species not at present known. It is not the common buffalo, nor can it be identified with the large buffalo of India, named arnee. Cuvier conjectures that it must have lived at the same time with the fossil elephant and rhinoceros, in the frozen regions of Siberia.

4. *Fossil ox, resembling the musk ox of America*.—More nearly resembling the American musk ox than any other species, and have hitherto been found only in Siberia.

These fossil remains of deer and oxen may be distinguished into two classes, the unknown and the known ruminants. In the first class Cuvier places the Irish elk, the small deer of Etampes, the stag of Scania, and the great buffalo of Siberia; in the second class he places the common stag, the common roe-buck, the fallow deer, the aurochs, the ox which seems to have been the original of the domestic ox, the buffalo with approximated horns, which appears to be analogous to the musk ox of Canada; and there remains a dubious species, the great deer of Somme, which much resembles the common fallow-deer.

‘From what has been ascertained in regard to the strata,’ says Mr. Jameson, in which these remains have been found, it would appear that the known species are contained in newer beds than the unknown. Further, that the fossil remains of the known species are those of animals of the climate where they are now found: thus the stag, ox, aurochs, roe-deer, fallow deer, now dwell, and have always dwelt, in cold countries; whereas the species which are regarded as unknown appear to be analogous to those of warm countries: thus the great buffalo of Siberia can only be compared with the buffalo of India, the arnee. M. Cuvier concludes that the facts hitherto collected seem to announce, at least as plainly as such imperfect documents can, that the two sorts of fossil ruminants belong to two orders of alluvial deposits, and consequently to two different geological epochs; that the one have been, and are now, daily becoming enveloped in alluvial matter; whereas, the others have been the victims of the same revolution which destroyed the other species of the alluvial strata; such as mammoths, mastodons, and all the multungula, the genera of which now exist only in the torrid zone.

#### Order V.—MULTUNGULA.

*Rhinoceros antiquitatis*.—Only one fossil species has hitherto been discovered, which differs from the five living species, not only in structure, but in geographical distribution. It was first noticed in the time of Grew, in alluvial soil near Canterbury. Sir E. Hone describes, in the Philosophical Transactions for 1817, a nearly perfect head of this species, which was found in a cave in limestone, near Plymouth. Similar remains have been found in many places of Germany, France, and Italy. In Siberia, not only single bones and skulls, but the whole animal, with the flesh and skin, have been discovered.

*Hippopotamus*.—Two fossil species have been ascertained by Cuvier. The one, which is the largest, is so very nearly allied to the species at present living on the surface of the earth, that it is difficult to determine whether or no it is not the same. Its fossil remains have been found in alluvial soil in France and Italy. The second fossil species, and the smallest, not being larger than a hog, is well characterised, and is entirely different from any of the existing species of quadrupeds.

*Tapir*.—The tapir, until lately, was considered as an animal peculiar to the new world, and confined to South America; but the recent discovery of a new species in Sumatra proves that it also occurs in the old world. Two fossil species of this genus have been discovered in Europe. The one is named the small, the other the gigantic tapir, and both have been found in different parts of France, Germany, and Italy.

*Elephas jubatus, or primigenus, elephant or mammoth*.—Of this genus two species are at present known as inhabitants of the earth. The one, which is confined to Africa, is named the African elephant; the other, which is a native of Asia, is named the Asiatic elephant. Only one fossil species has hitherto been discovered. It is the mammoth of the Russians. It differs from



both the existing species, but agrees more nearly with the Asiatic than the African species. It appears to have been clothed in fur, and provided with a mane. Its bones have been found in many different parts of this island; as in the alluvial soil around London, in the county of Northampton, at Gloucester, at Trenton, near Stafford, near Harwich, at Norwich, in the island of Sheppy, in the river Medway, in Salisbury Plain, and in Flintshire in Wales; and similar remains have been dug up in the north of Ireland. Bones of this animal have been dug up in Sweden, and Cuvier conjectures that the bones of supposed giants, mentioned by the celebrated bishop Pontoppidan as having been found in Norway, are remains of the fossil elephant. Toræus mentions a head and tooth of this animal dug up in the island of Iceland. In Russia, in Europe, Poland, Germany, France, Holland, and Hungary, teeth and bones of this species of elephant have been found in abundance. Humboldt found teeth of this animal in North and South America. But it is in Asiatic Russia that they occur in greatest abundance. Pallas says, that from the Don or the Tanais to Tichutskoinoss, there is scarcely a river the bank of which does not afford remains of the mammoth; and these are frequently imbedded in, or covered with alluvial soil containing marine productions. The bones are generally dispersed, seldom occurring in complete skeletons, and still more rarely do we find the fleshy part of the animal preserved. One of the most interesting instances on record of the preservation of the carcase of this animal is thus given by M. Cuvier:—

‘In the year 1799, a Tungusian fisherman observed a strange shapeless mass projecting from an ice-bank, near the mouth of a river in the north of Siberia, the nature of which he did not understand, and which was so high in the bank as to be beyond his reach. He next year observed the same object, which was then rather more disengaged from among the ice, but was still unable to conceive what it was. Towards the end of the following summer, 1801, he could distinctly see that it was the frozen carcase of an enormous animal, the entire flank of which, and one of its tusks, had become disengaged from the ice. In consequence of the ice beginning to melt earlier, and to a greater degree than usual in 1803, the fifth year of this discovery, the enormous carcase became entirely disengaged, and fell down from the ice craig on a sand-bank forming part of the coast of the Arctic Ocean. In the month of March of that year the Tungusian carried away the two tusks, which he sold for the value of fifty rubles; and at this time a drawing was made of the animal of which I possess a copy.

‘Two years afterwards, or in 1806, Mr. Adams went to examine this animal, which still remained on the sand bank where it had fallen from the ice, but its body was then greatly mutilated. The Jukuts of the neighbourhood had taken away considerable quantities of its flesh to feed their dogs; and the wild animals, particularly the white bears, had also feasted on the carcase; yet the skeleton remained quite entire,

except that one of the fore legs was gone. The entire spine, the pelvis, one shoulder-blade, and three legs, were still held together by their ligaments, and by some remains of the skin; and the other shoulder-blade was found at a short distance. The head remained, covered by the dried skin, and the pupil of the eye was still distinguishable. The brain also remained within the skull, but a good deal shrunk and dried up; and one of the ears was in excellent preservation, still retaining a tuft of strong bristly hair. The upper lip was a good deal eaten away, and the under lip was entirely gone, so that the teeth were distinctly seen. The animal was a male, and had a long mane on its neck.

‘The skin was extremely thick and heavy, and as much of it remained as required the exertions of ten men to carry away, which they did with considerable difficulty. More than thirty pounds weight of the hair and bristles of this animal were gathered from the wet sand-bank, having been trampled into the mud by the white bears while devouring the carcase. Some of the hair was presented to our Museum of Natural History by M. Targe, censor in the Lycæum of Charlemagne. It consists of three distinct kinds. One of these is stiff black bristles, a foot or more in length; another is thinner bristles, or coarse flexible hair, of a reddish-brown color; and the third is a coarse reddish-brown wool, which grew among the roots of the long hair. These afford an undeniable proof that this animal had belonged to a race of elephants inhabiting a cold region, with which we are now unacquainted, and by no means fitted to dwell in the torrid zone. It is also evident that this enormous animal must have been frozen up by the ice at the moment of its death. Mr. Adams, who bestowed the utmost care in collecting all the parts of this animal, proposes to publish an exact account of its osteology, which must be an exceedingly valuable present to the philosophical world. In the mean time, from the drawing I have now before me, I have every reason to believe that the sockets of the teeth of this northern elephant have the same proportional lengths with those of other fossil elephants, of which the entire skulls have been found in other places.’

*Sus proavitus, hog.*—Only single bones and teeth of this tribe have been hitherto met with; some of these appear to belong to the *sus scrofa*, or common hog; while others are of a dubious nature. They are found in loam, along with the remains of the elephant and rhinoceros, and even imbedded in peat mosses.

*Mastodon. Mammoth of Blumenbach.*—This is entirely a fossil genus, no living species having hitherto been discovered in any part of the world. It is more nearly allied to the elephant than to any other animal of the present creation; it appears to have been an herbivorous animal; and the largest species, the great mastodon of Cuvier, was equal in size to the elephant.

Five species are described by Cuvier. 1. Great mastodon, mammoth ohioiticum of Blumenbach.—This species has been hitherto found in greatest abundance in North America, near the river Ohio, and remains of it have been dug up

in Siberia. It has been frequently confounded with the mammoth or fossil elephant, and in North America it is named mammoth. In plate II. we have given an engraving of one of the grinding teeth of this animal. 2. Mastodon with narrow grinders.—The fossil remains of this species have been dug up at Simorre and many other places in Europe, and also in America. 3. Little mastodon with small grinders.—This species is much less than the preceding, and was found in Saxony and Montabusard. 4. Mastodon of the cordilleras.—This species was discovered in South America by Humboldt. Its grinders are square, and it appears to have equalled in size the great mastodon. 5. Humboldtien mastodon.—This, which is the smallest species of the genus, was found in America by Humboldt.

All the fossil species of quadrupeds we have just enumerated have been found in the alluvial soil which covers the bottoms of valleys, or is spread over the surface of plains. All of them are strangers to the climate where these bones now rest.

*Palaotherium*, i. e. ancient large animal or beast. A new and entirely fossil genus found by Cuvier in the rocks around Paris. The following are the characters of the genus and the species:—

- Dentes 44. Primores utrinque 6.  
Laniarii 4, acuminati paulo longiores, tecti.  
Molares 28, utrinque 7. Superiores quadrati; inferiores bilunati.  
Nasus productior, flexilis.  
Palmæ et plantæ tradactylæ.
1. P. Magnum. Statura Equi.
  2. P. Medium. Statura Suis; pedibus strictis, subelongatis.
  3. P. Crassum. Statura Suis; pedibus latis, brevioribus.
  4. P. Curtum. Pedibus ecurtatis patulis.
  5. P. Minus. Statura Ovis; pedibus strictis, digitis lateralibus minoribus.

Besides these five species found in the gypsum quarries around Paris, remains of others have been discovered in other parts of France, either imbedded in the fresh-water limestone, or in alluvial soil. Cuvier enumerates and describes the following species:—

6. P. Giganteum. Statura rhinocerotis.
7. P. Tapiroides. Statura bovis; molarium inferiorum colliculis fore rectis, transversis.
8. P. Buxovillanum. Statura suis; molaribus inferioribus extus sub gibbosis.
9. P. Aurelianensi. Statura suis; molarium inferiorum angulo intermedio bicorni.
10. P. Occitanum. Statura ovis; molarium inferiorum angulo intermedio bicorni.

*Anoplotherium*, i. e. beast without weapons, referring to its distinguishing character, the want of canine teeth. This also is another fossil genus first discovered by Cuvier. The following are its characters:—

- Dentes 44, seria continua.  
Primores utrinque 6.  
Laniarii primoribus similes, ceteris non longiores.

Molares 28, utrinque 7. Anteriores compressi. Posteriores superiores quadrati. Inferiores bilunati.

Palmæ et plantæ didactylæ, ossibus metacarpi et metatarsi discretis; digitis accessoriis in quibusdam.

1. A. Commune. Digito accessorio duplo breviori, in palmis tantum; cauda corporis longitudine crassissima.  
Magnitudo asini aut equi minoris.  
Habitus elongatus et depressus lutræ.  
Versimiliter natatorius.
2. A. Secundarium. Similis præcedenti, sed statura suis. E tibia et molaribus aliquot cognitum.
3. A. Medium. Pedibus elongatis, digitis, accessoriis nullis.  
Magnitudo et habitus elegans Gazellæ.
4. A. Minus. Dinito accessorio utrinque, in palmis et plantis, intermedios fere æquante.  
Magnitudo et habitus leporis.
5. A. Minimum. Statura cavæ cobayæ, e maxilla tantum cognitum.  
Habitatio omnium, olim in regione ubi nunc Lutetia Parisiorum.

#### Order VI.—PALMATA.

##### Family. *Glires*.

*Castor, beaver*.—Two species are found in alluvial soil of different kinds:—the one, which is the castor fiber, or common beaver, has been found in marl pits and peat bog, in Perthshire and Berwickshire, in Scotland, and also in France; the other (on the shores of the sea of Azof by M. Fischer) differs from the former and is named castor trogontherium.

##### Family. *Feræ*.

*Phoca, seal*.—A species of seal nearly three times the size of the common seal, or phoca vitulina, has been found in the coarse marine limestone of the department of the Maine and Loire. Another species of this genus, but somewhat less than the common, is also described by Cuvier.

##### Family. *Bruta*.

*Lamantin*.—Two species have been found imbedded in the coarse marine limestone of the department of the Maine and Loire.

#### CLASS II.—AVES.

*Sturnus, starling*.—Occurring in the formations around Paris.

*Coturnix, quail*.—Bones of this tribe have been also found in the strata near Paris.

*Sterna, tern*.—Bones of terns are occasionally found along with those of the quail.

*Grallæ, wadders*.—Bones of birds resembling those of the order grallæ have been found near Paris in the solid rocks.

*Pelicanus' pelican*.—Bones resembling those of the pelican tribe occur in the Paris formations. Fossil remains of birds are also said to have occurred in the limestone of Solenhoff and Pappenheim.

## CLASS III.—AMPHIBIA.

## Order.—REPTILIA.

*Testudo, tortoise*.—Remains of this genus are met with in different parts of Europe; and tortoises, of unknown species, are found imbedded in coarse marine limestone in the environs of Brussels: also in the coarse chalk or limestone of the hill of Saint Peter, near Maestricht. They are irregularly distributed throughout the masses of the rock, along with different marine productions, and bones of the gigantic monitor. All of them are remains of sea-tortoises, named *chelonii* by French zoologists; but of different species from those at present known. An unknown species of tortoise has been found in the limestone slate of Glaris; and remains of unknown species have been dug out of the rocks of the vicinity of Aix. Fossil fresh-water species have also been found in the gypsum quarries near Paris.

*Crocodylus, crocodile*.—Two extinct species of fossil crocodiles, nearly allied to the gavia (Lat. gangeticus), or gangetic crocodile, occur in a pyritical bluish-gray compact limestone, at the bottom of the cliffs of Honfleur and Havre: one of these species at least is found in other parts of France. It would also appear that the skeleton of a crocodile, discovered at the bottom of a cliff of pyritical slate, about half a mile from Whitby, by captain William Chapman, belongs to one of these species. Fragments of heads of crocodiles found in the Vicentine may be referred to the same species. The remains of an unknown species of fossil crocodile was found near Newark, in Nottinghamshire, by Dr. Stukely. The supposed crocodiles found along with fish in the copper slate, or bituminous marl slate, of Thuringia, are reptiles of the genus monitor. All these fossil remains of oviparous quadrupeds belong to old flætz strata, far older than the flætz rocks that contain unknown genera of true quadrupeds, such as the palæotheriums and anoplotheriums; which opinion, however, does not oppose the finding of the remains of crocodiles with those of these genera, as has been done in the gypsum quarries.

*Monitor*.—In the quarries of Maestricht there occur remains of a large fossil monitor. This, which is one of the most celebrated of all the fossil species of oviparous quadrupeds, occurs in a soft limestone which contains flint, and the same kinds of petrifications as are observed in the chalk near Paris. It had engaged the attention of enquirers in 1766, and up to the present day has not ceased to be an object of discussion and investigation. Some have described it as a crocodile, others as a whale; and it has even been arranged along with fishes. Cuvier, after a careful study of its osteology, ascertained that it must have formed an intermediate genus between those animals of the lizard tribe which have a long and forked tongue, and those which have a short tongue and the palate armed with teeth. The length of the skeleton appears to have been nearly twenty-four feet. The head is a sixth of the whole length of the animal; a proportion approaching very near to that of the crocodile, but differing much from that of the monitor, the

head of which animal forms hardly a twelfth part of the whole length. The tail must have been very strong, and its width at its extremity must have rendered it a most powerful oar, and have enabled the animal to have opposed the most agitated waters. From this circumstance, and from the other remains which accompany those of this animal, Cuvier is of opinion that it must have been an inhabitant of the ocean.

*Salamandra, salamander*.—In the valley of Altmühl, near Aichsted and Pappenheim, and at Aeningen, there is a formation of calcareous slate, belonging to the Paris formation, rich in petrifications. One of the most remarkable of these is that described by Scheuchzer, under the name *homme fossile*, and which some naturalists, as Gesner, maintained to be the *siluris glanis* of Linnæus, but which is, in reality, nothing more than an unknown and probably extinct species of salamander or proteus. It was found imbedded in the limestone of Aeningen.

*Bufo, toad*.—Remains of an animal of this tribe occur in the slaty limestone of Aeningen. Dr. Karg, who has published a long description of the Aeningen quarries, is of opinion, that this petrification is that of a common toad; whereas Cuvier is inclined to refer it to some species nearly allied to the *bufo calamita*.

*Fossil saurus of Cuvier*.—Only one specimen of this remarkable fossil animal has hitherto been found, and is now in the cabinet of the king of Bavaria. In regard to this specimen, it may be remarked, that some naturalists have taken it for a bird, others for a bat, but Cuvier is of opinion that it belongs to the class amphibia. Its true nature is still unascertained, although it appears more nearly allied to the class mammalia than to any of the others in the system.

## CLASS IV.—PISCES.

‘The accuracy of La Cèpede’s list of the fossil fishes of Bolca, Aeningen, and Hestia, has been much questioned by naturalists,’ says Mr. Jameson, ‘and Cuvier has hitherto paid but little attention to this branch of geology. He only enumerates in a very general way the few met with in the gypsum quarries around Paris. Five species are mentioned. The first described belongs to a new genus allied to that named *amia*, and is conjectured to be a fresh-water species. The second is nearly allied to two fresh-water genera, viz. the *mormyrus* of La Cèpede, natives of the river Nile, and the *pæcilia* of Bloch, natives of the fresh waters of Carolina. The third appears to be a species of *sparus*, different from any of the present species. The fourth and fifth are very dubious. The bituminous marl slate of Germany abounds in fossil fishes. Schlottheim mentions a fossil fish found in this rock, as being five feet in length, and six inches broad, which he conjectures to belong to the genera *cyprinus* or *Salmo*. Petrified specimens, supposed of the *salmo arcticus*, are found in a bluish-gray clay in West Greenland. Single bones, as vertebræ, teeth, also scales of fishes, are found in the shell limestone, chalk, and in the rocks of the Paris formation.

Fig. 1.  
*Ornithocephalus longirostris*.  
In the Limestone of Eichelstadt.

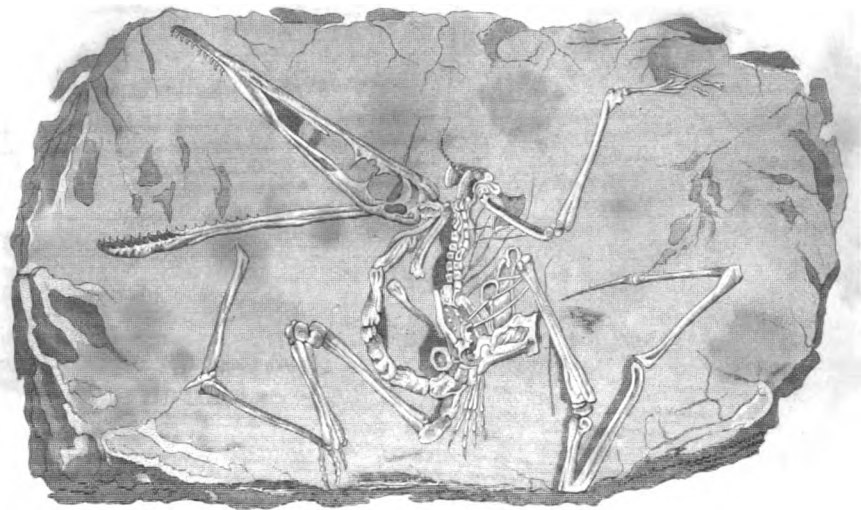


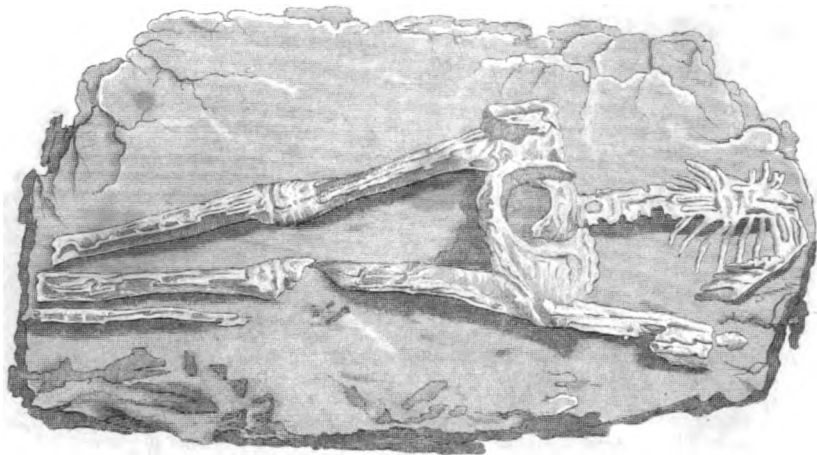
Fig. 2.

*Ornithocephalus  
brevirostris*



PAGE 303.

Fig. 3.  
*Fossil Human Skeleton*





Thus far we have travelled with the able translation of Cuvier's Essay edited by Mr. Jameson, and have only to regret that he did not complete the catalogue of existing remains in that work. Two or three important classes must be gleaned from other sources.

#### CLASS V.—AVES.

The remains of birds are rarely found in a fossil state. Bones, which may be considered as referrible to this class, are, however, imbedded in the calcareous schist of Oeningen, and in the oolitic schist of Stonesfield. The foot of a bird has been found incrustated in gypsum, near Montmartre; Blumenbach describes the bones of a water-fowl in the Pappenheim stone; and Faujas St. Fond has figured two feathers found in the calcareous stone of Vestena Nuova.

Cuvier, however, has not only ascertained the existence of fossil remains of this class, but has furnished the student with information to aid him in his investigations with respect to these fossils. The foot, he observes, in birds, has a single bone in the place of the tarsal and metatarsal bones. Birds, too, form the only class in which the toes all differ as to the number of joints, and in which this number, and the order of the toes which have them, is nevertheless fixed. The great toe has two; the first toe, reckoning on the inside, three; the middle, five; and the outermost five. The crocodile has the same number of phalanges; but, as these have a tarsal and metatarsal bone, they cannot be mistaken. Some birds have no great toes, but, in these, the other toes preserve the usual order: the ostriches and cassowars have three toes. Although the crocodile has the same number of phalanges, yet, as every one of the toes is supported by a particular metatarsal bone, the distinction is easily made. From an attention to the specific characters, Cuvier ascertained the existence of the remains of five or six different species of birds in the plaster quarries near Paris. Among these are the bones of a pelican, less than pelicanus onocratulus, and larger than *P. carbo*; of one of the larger curlews, with a naked neck (*Tantalus*, Gmelin); of a woodcock, a starling, and a sealark (*Alouette de Mer*). He also describes and figures a bird, found in the quarries of Montmartre, which appears to have fallen on its belly on the newly-formed gypsum, without having been quite involved in it; and having, probably whilst in this state, been deprived of its head and the whole of the right leg. The result of a careful examination of this fossil is, that it belongs to some exotic quail, rather larger than the one known in France.

And here perhaps we may best introduce the *ornithocephalus*, although naturalists are not agreed as to its correct place. It is entirely a fossil genus. Cuvier refers it to the amphibia; others, as Blumenbach, to birds; Collini describes it as a fish; while Sömmering arranges it, as a bat, with the mammalia. The skull is enormous in proportion to the skeleton, the jaws themselves being longer than the body, and furnished with sharp incurvated teeth. The head of the *O. longirostris* resembles that of the curlew tribe, while the *brevirostris* more nearly resembles the bat, particularly the *vespertilio*

murinus. The orbits of the eyes are disproportionately large, and hence it is thought probable that, like the bat, it was a nocturnal animal, while, from the size of its jaws, it is likely that it fed on small flying insects. There are four legs (the hinder ones being of considerable length), and a distinct tail. There are no tarsal bones, only metatarsal bones and claws. Two species are described by Sömmering, the largest about a foot long, named *O. longirostris*; the other, which is less, *O. brevisrostris*. See plate II. figs. 1 & 2.

#### CLASS VI.—INSECTA.

Insects also are of rare occurrence as fossils. Scheweigga mentions a perfect scorpion, different from the common genus, found in a piece of amber; ants of the present species have also been found in amber: supposed larvæ of the *libellula* and *ephemera* genera have likewise been mentioned, and the elytra of coleopterous insects as occurring in the Stonesfield slate.

#### CLASS VII.—RELIQUA OCEANA.

We are compelled to rank under this general head all the crustacea, mollusca, radiaria, and polypi of authors. Of the first the mutilations are so great, and they are so enclosed, that often nothing is to be seen but parts of the thorax or upper surface of the body: the antennæ and feet are commonly broken and separated from the body; while the under surface, or numerous pieces of the plastron, or sternum, giving attachment to feet composed of many articulations, present also the external parts of the mouth. The want of the antennæ and feet induced Desmarest to restrict the distinctions to characters obtained from the shell or thorax. The various prominences of the latter, he continues, are not irregular and accidental; on the contrary, in all the genera the disposition of these inequalities is constant, and subjected to certain laws. We have been the more inclined, he remarks, to admit these relations, that it is known at a certain period of the year all the crustacea, after having lost their old solid envelope, are covered with a delicate skin, which hardens in its turn, and at the end of a few days changes into a crust equally resisting with that which it substitutes; and we might presume that in the first moments the new skin moulded itself to a certain point upon the internal organs, and that its ossification was subsequently influenced by the motions peculiar to these organs, or by the greater or less development of each of them. He describes on this plan twenty genera, and a considerable number of species from different parts of Europe, Asia, and Africa. Many occur in Great Britain, principally in England, in the chalk formations, as well as in the plastic clay of Sheppey and other places.

*Mollusca*.—Fossil shells are perhaps the most abundant of all organic remains: and occur from the size of several feet in diameter to microscopic objects. They are divided into univalve, bivalve, and multivalve shells.

Univalve shells with but one chamber are called *unilocular*, and of these between seventy and eighty genera have been specified; while of the *multilocular*, or many chambered univalves, not more

than twenty-five occur. Dr. Montfort, author of an important work, *Conchyliologie Systematique*, has, indeed, with much discrimination separated the multilocular univalves into many more genera: the microscopic shells into sixty; and those which are within the power of the naked eye, being those which had been included in nautilus, ammonites, belemnites, orthoceratites, spirula, scaphites, nummulites, and siderolites, into forty genera; forming almost every shell, marked by a slight difference, into a distinct genus. These separations, although perhaps founded on accurate discrimination, appear, as Mr. Parkinson observes, to be too frequent; their multiplicity bears too much on the memory, and deprives it of the aid which it seeks to derive from classification. A more intimate knowledge of their nature and characteristics seems to be necessary before an appropriate arrangement of them can be adopted. The larger tribe has been separated into twenty-two genera, all of which have been found in a fossil state: whilst one genus only, nautilus, is known to exist in a recent state. Two opinions are entertained respecting this great disproportion between the number of fossil and of recent shells of this tribe. Some suppose that those genera, of which only fossil shells are found, have become extinct; whilst others believe that these shells are still existing in a recent state: but are pelagian shells, their inhabitants constantly residing at the bottom of the deep. This opinion is entertained by some of the latest French writers.

An examination of these shells proves, however, according to Mr. Parkinson, that, so far from their inhabitants having been destined to a constant residence at the bottom of the ocean, they possessed, beyond all other testaceous animals, the power of rising up to, and remaining at, the surface of the sea. Supposing them still to live, they would occasionally, as the nautilus is, be seen at the surface; but, not a single instance being known of a shell of these genera having been thus seen, their existence may be reasonably doubted. The apparatus enabling the animal to raise or sink himself at pleasure is plainly discoverable in the fossil shell of the nautilus: but the most important part of this organ, the continuous siphuncle, is not discoverable in the dried specimens of the recent shell. The shell is formed of a number, more or less, of chambers, divided by pierced septa. The animal resides in the largest and last formed chamber; an elastic tube, proceeding from the animal, passes through the pierced septa and the several chambers, and terminates in the first. Now, assuming that the office of this tube is analogous with that of the swimming bladder of fishes, it is by no means difficult to conceive how the required changes of situation may be produced. The weight of the shell is so counterbalanced by the empty chambers, that the siphuncle passing through these chambers, accordingly as it is dilated with gaseous or with aqueous fluids, will alter the specific gravity of the whole mass, and cause it either to swim or to sink. Supposing

the animal to be lying at the bottom of the sea, saturated with food, and the siphuncle filled with a fluid; as the food is digested and decomposed, detached gas may pass into the siphuncle, and gradually take the place of the water; when, in proportion as the specific gravity of the whole mass is thus diminished, it will rise, probably into that region of the waters in which the food of the animal most abounds. Here, on obtaining sufficient food, or on alarm from an enemy, the animal admits water into the siphuncle, and immediately sinks. In all the other genera of this tribe, an apparatus, formed of vacant chambers and a membranous siphuncle, exists, capable of producing similar effects with those produced by that of the nautilus; but necessarily differing in some respects, from variety of modification of the form and structure peculiar to each genus. The siphuncle is often very well displayed in sections of the orthoceratite, and in these this tube will be found to have been capable of being dilated to a very considerable extent.

With the nautilus agree in general at a ratio the orthoceratite, the belemnite, and the baculite species: other abundant tribes of multivalves are the ammonites and nummulites; the former being the vulgar petrified serpents; and whole masses of limestone being entirely made up of the latter: as, for instance, that with which the pyramids of Egypt are built.

Bivalve fossils are so varied in their forms that we can only refer the reader for a description of them to Mr. Parkinson's Introduction, or some other of the various treatises on fossil conchology. The multivalves are of unfrequent occurrence.

*Radiaria*.—Of the echinus, or sea urchin family, a great variety is met with in several of the newer rocks. Some of the species resemble those at present met with in our seas. The asterias or sea star family, from their delicacy and frail structure, are rarely met with. The crinoidea, or encrinite family, abound in many strata, and in vast abundance, but very rarely in a living state. Blumenbach first conjectured their affinity to the radiaria; and Miller, in his late work on the crinoidea, has removed every doubt as to their true place in the system. The entrochites and encrinites belong to this family.

*Polypi*.—We may include under this head the different kinds of simple animals named polypi, and their coverings, termed polyparia. The corals are polyparia, and many of these occur in a fossil state. The alcyonia and sponges are likewise to be included. In the fresh state the former are nearly as soft as sponge, but have openings on the surface, through which polypi project. They occur frequently in flints. Sponges are composed of horny fibres connected together by means of an animal jelly, but no distinct polypi have been detected in them. They occur in a fossil state, and are abundant in the flint and chalk formations. We add from Mr. Parkinson's work

A TABLE OF BRITISH FOSSIL SHELLS.

Each Genus and each Species being placed in the order of the Strata in which they occur

Genera.	Species.	Strata.
PRODUCTUS.	longispinus	MOUNTAIN LIMESTONE.
	Flemingii	ditto
	spinulosus	ditto
	scoticus	ditto
	spinosus	ditto
	aculeatus	Limestone rock (coal measures).
	scabriculus	ditto
	aculeatus	ditto
CONULARIA.	quadrisulcata	MOUNTAIN LIMESTONE.
	teres	ditto
AMPLEXUS.	coralloides	MOUNTAIN LIMESTONE.
PENTAMERUS.	Knightii	MOUNTAIN LIMESTONE.
	lævis	ditto
	Aylesfordii	ditto
ORTHOcera.	annulata	MOUNTAIN LIMESTONE.
	circularis	ditto
	striata	ditto
	gigantea	ditto
	cordiformis	ditto
	undulata	Gray limestone (coal measures).
	Breynii	Limestone shale.
	Steinhaurii	Coal shale.
	conica	Alum shale.
	NAUTILUS.	discus
pentagonus		ditto
bilobatus		ditto
tuberculatus		ditto
complanatus		Slaty limestone.
truncatus		Blue lias.
striatus		ditto.
intermedius		Blue lias and crag.
lineatus		Lower oolite.
sinuatus		ditto
obesus		ditto
simplex		Green sand.
undulatus		ditto
inæqualis		Chalk marl
elegans		ditto
Comptoni		ditto
imperialis		London clay
centralis		ditto
ziczac		ditto
AMMONITES.		striatus
	sphæricus	ditto
	Walcotii	ditto
	Henslowi	Alum shale. Lower oolite. Upper oolite.
	Listeri	Gray limestone, Isle of Man.
	annulatus	Coal shale.
	ellipticus	Alum shale. Lower oolite.
	planicosta	White lias clay.
	communis	{ Upper lias clay. Marston or lias marb'le.
	armatus	? Chalk marl.
	angulatus	White lias clay.
	Bucklandii	Lias clay.
	Coneybeari	ditto



Genera.	Species.	Strata
<b>AMMONITES.</b>	Greenoughi	Blue lias
	fimbriatus	ditto
	obtusus	ditto
	Henleyi	ditto
	Loscombi	ditto
	Birchi	ditto
	Brooki	ditto
	Bechei	ditto
	Brongniarti	<b>Lower oolite.</b>
	Banksii	ditto
	Blagdeni	ditto
	Brocchii	ditto
	Sowerbii	ditto
	Browni	ditto
	Gervillii	ditto
	Strangewaysi	ditto
	falcifer	ditto
	nodosus	Clay under the lower oolite.
	discus	Cornbrash.
	Calloviensis	Kelloway rock.
	Koenigi	ditto
	Duncani	Clunch clay under coral rag, or Oxford clay.
	excavatus	Calcareous grit beneath coral rag.
	vertebralis	ditto
	plicatilis	ditto
	splendens	Coral rag. Chalk marl.
	jugosus	Clay under the lower oolite.
	elegans	ditto
	concavus	ditto
	cordatus	Kentish rag.
	rotundus	Kimmeridge clay.
	Lamberti	ditto
	Leachi	ditto
	omphaloides	ditto
	triplicatus	Portland freestone.
	stellaris	ditto
	giganteus	ditto
	Goodhalli	Green sand, Devon.
	Nutfieldiensis	Green sand.
	monile	ditto
	inflatus	ditto
	auritus	ditto
	rostratus	Chalk marl.
	minutus	ditto
	varians	ditto
	Mantelli	ditto
	rusticus	Lower chalk.
	biplex	Blue clay, Suffolk.
	decipiens	ditto.
	acutus	Blue clay, Sheppey.
	binus	Crag.
	quadratus	ditto
	serratus	ditto
<b>NAUTELLIPSITES.</b>	ovatus	<b>MOUNTAIN LIMESTONE.</b>
<b>AMMONELLIPSITES.</b>	funatus	ditto
	compressus	<b>MOUNTAIN LIMESTONE.</b>
<b>EUOMPHALUS.</b>	pentangulus	ditto
	catillus	ditto
	nodosus	ditto
	discors	ditto
	rugosus	ditto
	angulosus	ditto

Genera.	Species.	Strata.
CIRRUS.	acutus	MOUNTAIN LIMESTONE.
	nodosus	ditto
	leachi	Lower oolite.
	plicatus	Chalk marl.
PLANORBIS.		ditto
	æqualis	MOUNTAIN LIMESTONE.
	euomphalus	ditto
	radiatus	{ Lower oolite. Green sand. Above the London
	hemistoma	clay.
	lens	Green sand.
SPIRIFER.	cylindricus	London clay.
	obtusus	Above the London clay.
		ditto
		ditto
		MOUNTAIN LIMESTONE.
		ditto
TEREBRATULA.	cuspidatus	ditto
	trigonalis	ditto
	oblatus	ditto
	glaber	ditto
	obtusus	ditto
	striatus	ditto
	pinguis	ditto
	Mantiæ	MOUNTAIN LIMESTONE.
	Wilsoni	ditto
	lateralis	ditto
biplicata	Mountain limestone. Clay of upper oolite.	
crumena	Mountain limestone. Green sand. Chalk marl.	
punctata	Coal shale. Blue lias marble (Marston).	
subrotunda	Marly sandstone of lower oolite.	
ornithocephala	Ditto. Cornbrash. Chalk marl.	
acuta	Upper lias clay. Cornbrash.	
resupinata	Lower oolite.	
lampas	ditto	
digona	ditto	
obovata	Lower oolite. Oxford clay. Cornbrash.	
intermedia	Cornbrash.	
obsoleta	Cornbrash. Green sand.	
concinna	Cornbrash. Crag.	
media	Clay in oolite.	
tetraëdra	ditto	
carnea	ditto	
inconstans	Great oolite. Upper chalk.	
dimidiata	Kimmeridge clay.	
ovata	Green sand, Devon.	
pectinata	Green sand	
lyra	ditto?	
semiglobosa	Green sand.	
subundata	Chalk marl.	
plicatilis	Upper chalk.	
octoplicata	ditto	
obliqua	ditto	
ovoides	ditto	
lata	Green sandstone in alluvium.	
GRYPHÆA		ditto
		MOUNTAIN LIMESTONE.
CARDIUM.	incurva	Blue lias. Kelloway stone. Crag.
	dilatata	{ Under oolite. Clunch clay.
		{ Portland freestone. London, clay, alluvia.
	MOUNTAIN LIMESTONE.	
	ditto	
	ditto	
	Green sand, Devon.	
	ditto	
	ditto	
	London clay.	
	ditto	
	Crag	

Genera.	Species.	St. etc.
HELIX.		{ 4th LIMESTONE, above the MOUNTAIN. { LIMESTONE.
	carinatus	ditto
	Gentii	Green sand.
LINGULA.	globosus	Above the London clay.
	mytilloides	COAL SHALE.
	tenuis	ditto
UNIO.	ovalis	London clay
	acutus	Crag.
	uniformis	COAL SHALE.
	subconstrictus	ditto
	hybridus	ditto
	Listeri	Coal shale, alluvial clay.
	crassissimus	Magnesian limestone.
	crassiusculus	Magnesian limestone. Crag.
PLAGIOSTOMA.		Lias. Portland freestone.
	gigantea	London clay.
	pectinoides	LIAS.
	punctata	White lias. Blue lias.
	ovalis	Blue lias.
	cardiiformis	ditto
	obscura	Fullers' earth.
	rigida	Upper oolite.
	spinosa	Kelloway rock.
TROCHUS.		Portland freestone.
	anglicus	Lower chalk. Upper chalk.
	abbreviatus	LIAS.
	concauus	Blue lias
	dimidiatus	Under oolite.
	duplicatus	ditto
	elongatus	ditto
	punctatus	ditto
	agglutinaus	ditto
	Benettie	London clay.
	lævigatus	ditto
	similis	Crag.
MODIOLA.		ditto
	lævis	LIAS.
	depressa	ditto
	elegans	Alum shale. London clay.
	parallela	ditto
	pallida	Upper oolite
MELANIA.		Green sand.
	striata	LIAS.
	Heddingtonensis	ditto
	sulcata	Upper oolite.
HELICINA.		London clay.
	compressa	LIAS.
CARDITA.		ditto
	lirata	LIAS.
	obtusa	Lias. Cornbrash.
	similis	Under oolite.
	lunulata	ditto
	producta	ditto
	abrupta	Ditto. Cornbrash
	striata	Great oolite.
	deltoidea	ditto
	tuberculata	Cornbrash, Kelloway stone.
MYA.		Green sand.
	scripta	LIAS.
	angulifera	Lias. Kelloway rock.
	literata	Fullers' earth bed, near Bath.
	mandibula	Gray limestone, near Scarborough.
	plana	Green sand.
	intermedia	Sand under London clay.
	subangulata	London clay.
	lata	ditto
		Crag.

Genera.	Species.	Strata.	
<b>PECTEN.</b>	<i>fibrosus</i>	UNDER OOLITE.	
	<i>barbatus</i>	Under oolite. Cornbrash. Kelloway rock.	
	<i>equivalvis</i>	ditto	
	<i>obscura</i>	ditto	
	<i>lens</i>	Stonesfield slate.	
	<i>similis</i>	Cornbrash.	
	<i>rigida</i>	Forest marble.	
	<i>arcuata</i>	ditto	
	<i>lamellosa</i>	Coral rag.	
	<i>orbicularis</i>	Chicks Grove limestone. Green sand.	
	<i>quadricostata</i>	Green sand.	
	<i>quinquecostata</i>	ditto	
	<i>Beaveri</i>	ditto	
	<i>cornea</i>	Chalk marl.	
	<b>ASTARTE.</b>	<i>lurida</i>	London clay.
		<i>elegans</i>	UNDER OOLITE.
		<i>excavata</i>	ditto
<i>lineata</i>		ditto	
<i>cuneata</i>		{ Oaktree clay over Sussex marble, or Kimmeridge clay.	
<i>planata</i>		Portland stone.	
<i>plana</i>		Indurated marl at Gunton.	
<i>obliquata</i>		Crag.	
<b>TRIGONIA</b>	<i>costata</i>	ditto	
	<i>striata</i>	ditto	
	<i>clavellata</i>	ditto	
	<i>gibbosa</i>	Tisbury limestone.	
	<i>duplicata</i>	ditto	
	<i>dædalea</i>	Green sand, Devon.	
	<i>spinosa</i>	ditto	
	<i>eccentrica</i>	ditto	
	<i>affinis</i>	ditto	
	<b>CUCULLEA.</b>	<i>oblonga</i>	UNDER OOLITE.
<i>decussata</i>		ditto	
<i>carinata</i>		ditto	
<i>fibrosa</i>		Green sand, Devon.	
<i>glabra</i>		ditto	
<b>NERITA.</b>	<i>lævigata</i>	Green sand.	
	<i>sinuosa</i>	UNDER OOLITE.	
<b>LUTRARIA</b>	<i>gibbosa</i>	ditto	
	<i>ambigua</i>	Chilmarsh, near Tisbury.	
	<i>ovalis</i>	MIDDLE OF GREAT OOLITE.	
	<i>lirata</i>	Middle oolite	
<b>MYTILUS.</b>	<i>amplus</i>	Cornbrash.	
	<i>pectinatus</i>	Cornbrash. Upper oolite.	
	<i>antiquorum</i>	Limestone at Norton edge.	
	<i>alæformis</i>	MIDDLE OOLITE.	
<b>OSTREA.</b>	<i>acuminata</i>	ditto	
	<i>Marshii</i>	Kimmeridge clay.	
	<i>palmetta</i>	Crag.	
	<i>deltoidea</i>	ditto	
	<i>gregaria</i>	GREAT OOLITE.	
	<i>expansa</i>	{ Fullers' earth of great oolite. Clay over oolite,	
	<i>undulata</i>	{ and on Wooburn sand.	
	<i>Meadii</i>	Cornbrash.	
	<i>caniliculata</i>	Oxford clay.	
	<i>tener</i>	{ Oxford clay. Kimmeridge clay. Clay over Sussex marble.	
	Coral rag. Green sand.		
	Tisbury limestone.		
	Farley, near Salisbury.		
	Somersetshire.		
	Upper chalk.		
	Charlton.		

Genera.	Species.	Strata.
OSTREA.	gigantea	London clay.
	pulchra	London clay and gravel.
	flabellula	ditto
** Fossil oysters occur also in the lias formation.		
VENUS.	varicosa	CORNBRASH.
	lineolata	ditto
	planus	Green sand.
	angulata	ditto
	equalis	ditto
	incrassata	Green sand. Crag.
	margaritacea	London clay.
	gibbosa	ditto
	rustica	Crag.
ISOCARDIA.	lentiformis	ditto
	turgida	ditto
	minima	CORNBRASH.
	tener	ditto
PINNA.	rostrata	Kelloway stone.
	sulcata	Upper oolite.
		London clay (only a single individual).
VERMICULARIA.	lanceolata	CORNBRASH.
	margaritacea	Neighbourhood of Scarborough.
		London clay.
SOLARIUM.	ovata	UPPER OOLITE.
	concava	ditto
	umbonata	Green sand.
	crassa	Chalk marl.
HAMITES.	conoideum	London clay.
	discoideum	ditto
	patulum	ditto
	spinulosus	GREEN SAND, DEVON.
CHAMA.	tenuis	ditto
	rotundus	Chalk marl.
	attenuatus	ditto
	compressus	ditto
	adpressus	ditto
	maximus	ditto
	intermedius	ditto
	gibbosus	ditto
	armatus	ditto
	spiniger	ditto
	nodosus	ditto
	tuberculatus	ditto
	turgidus	ditto
	plicatulus	ditto
CORBULA.	canaliculata	GREEN SAND, DEVON.
	haliotidea	ditto
	recurvata	ditto
	conica	ditto
	digitata	ditto
ARCA.	levigata	GREEN SAND, DEVON.
	globosa	ditto
	pisum	ditto
	gigantea	London clay.
ARCA.	revoluta	ditto
	carinata	GREEN SAND.
	subacuta	ditto
	Branderi	Chalk marl.
appendiculata	Crag.	
	ditto	

Genera	Species.	Strata.
PERNA.	aviculoides	GREEN SAND. Blue marl under green sand.
VIVIPARA.	extensa ?	GREEN SAND.
	fluviorum	ditto
	lenta	Sussex marble.
	concinna	London clay.
	suboperta	ditto
DIANCHORA.	striata	Crag.
	lata	GREEN SAND. ditto
TURRILITES.	costata	Lower chalk.
	obliqua	GREEN SAND.
	tuberculata	Green sand. Chalk marl.
	undulata	Green sand.
SCAPHITES.	equalis	Chalk marl.
	obliquus	ditto
NUCULA.	pectinata	GREEN SAND.
	minima	ditto
	similis	Chalk marl.
	Cobboldia	CHALK MARL.
	lanceolata	ditto
	laevigata	London clay.
MAGAS.	pumilis	ditto
INFUNDIBULUM.	echinulatum	Crag.
	obliquum	ditto
	rectum	Chalk.
	tuberculatum	Upper chalk.
	spinulosum	LONDON CLAY, SAND UNDER.
	rectum	ditto
PECTUNCULUS.	plumstediensis	ditto
	costatus	ditto
	decussatus	ditto
EMARGINULA.	crassa	LONDON CLAY.
	reticulata	ditto
CYPRÆA.	oviformis	London clay. Crag.
OLIVA.	Branderi	LONDON CLAY.
	Salisburyana	ditto
ANCILLA.	aveniformis	ditto
	turritella.	ditto
CASSIS.	striata	LONDON CLAY.
	carinata	ditto
	bicatenatus	Crag.
AMPULLARIA.	acuta	LONDON CLAY.
	patula	ditto
	sigaretina	ditto
NATICA.	glaucinoïdes	ditto
	similis	ditto
	depressa	Crag.
ROSTELLARIA.	lucida	LONDON CLAY.
	rimosa	ditto
	macroptera	ditto

Genera.	Species.	Strata.
SCALARIA.	semicostata	LONDON CLAY.
	acuta	ditto
	similis	ditto
TEREBELLUM.		Crag.
SERAPHS.	fusiforme	LONDON CLAY.
		ditto
PLEUROTOMA.	convolutus	LONDON CLAY.
		ditto
	attenuata	ditto
	exorta	ditto
	rostrata	ditto
	acuminata	ditto
	comma	ditto
CERITHIUM.	semicolon	ditto
	colon	ditto
		LONDON CLAY.
	melanoides	ditto
	geminatum	ditto
	pyramidale	ditto
	funatum	ditto
	funiculatum	ditto
	intermedium	ditto
	dubium	ditto
cornucopiæ	ditto	
FUSUS.	giganteum	ditto
		LONDON CLAY.
	longævus	ditto
	bifasciatus	ditto
	acuminatus	ditto
	asper	ditto
VOLUTA.	rugosus	ditto
	bulbiformis	ditto
		LONDON CLAY.
	magorum	ditto
	luctator	ditto
MUREX	ambigua	ditto
	spinosa	ditto
	costata	ditto
	magorum	ditto
	Lamberti	ditto
		London clay. Crag.
		LONDON CLAY
	latus	ditto
	Bartonensis	ditto
	trilineatus	ditto
	coniferus	ditto
	regularis	ditto
	carinella	ditto
fistulosus	ditto	
gradatus	ditto	
tuberosus	ditto	
minax	ditto	
tubifer	ditto	
cristatus	ditto	
coronatus	ditto	
rugosus	ditto	
curtus	ditto	
striatus	ditto	
contrarius	Crag.	
rugosus	ditto	
corneus	ditto	
costellifer.	ditto	
echinatus	ditto	
VENERICARDIA.		LONDON CLAY.
	planicosta	ditto
	delloidea	ditto
	carinata	ditto
	senili	Crag.

Genera.	Species.	Strata.
SANGUINOLARIA.	Hollowaysii	LONDON CLAY. ditto
SOLEN.	affinis	LONDON CLAY. ditto
TEREDO.	antennatae	LONDON CLAY. ditto
BALANUS.	tesselatus crassus	LONDON CLAY. ditto ditto
BUCCINUM.	elongatum granulatum rugosum reticosum	CRAG. ditto ditto ditto ditto
EBURNA.	glabrata O. R. III.	CRAG. ditto
TELLINA.	obliqua ovata obtusa	CRAG. ditto ditto ditto
PHOLAS.	cylindricus	CRAG. ditto
PHASIANELLA	orbicularis minuta angulosa	SAND above LONDON CLAY. ditto ditto ditto
LYMNEA.	fusiformis minima	SAND above LONDON CLAY. ditto ditto
CYCLAS.	deperdita? cuneiformis obovata.	SAND above LONDON CLAY. ditto ditto ditto.

## CLASS VIII.—VEGETABLE FOSSIL REMAINS.

Mr. Parkinson thus ably traces not only the geology but genealogy of these remains. When vegetable matter is accumulated in so large a quantity that the compactness of the mass may in a great degree exclude the atmospheric air from the internal parts of the mass, a considerable and peculiar change is effected: the vegetable matter soon loses its green and acquires a brownish color; its flavor and odor are changed, and heat is to be produced, terminating, unless air is freely admitted, in combustion. The vegetable matter, thus changed into hay, acquires, among its other new properties, that of powerfully resisting any further change upon exposure to the atmosphere. But, should vegetable matter be thus accumulated in a situation in which moisture has almost constant access to it, a very different result ensues. Another process takes place, by which the vegetable matter, as the process goes on, loses its original forms, and becomes a soft magma, of a dark color and peculiar appearance; no traces of its former mode of existence being discoverable, except in the accidental presence of such vegetable matter as shall not have undergone a complete conversion. When dried, it forms a readily combustible substance, of a reddish-brown color, readily absorbing and tenaciously retaining water, and yielding, whilst burning, a strong bituminous odor. This is the substance termed peat, immense accumulations of which are formed in various parts, fa-

vorable to the collection of water and the growth of the sphagnum palustre, a plant by the conversion of which the supply of this substance is chiefly supported. In the peat-bogs or mosses, as the natural magazines of this substance are called, trunks of trees are often found imbedded, and partaking of the nature of the surrounding bituminous mass. This change is effected in different degrees; the deeper in the mass, and consequently the longer exposed to the process of bituminisation, the more perfect is the conversion. Some pieces are found to have nearly lost their ligneous appearance, their respective lines and markings having been molten down in different degrees during their bituminisation; whilst others, in which the nature of the substance is also entirely altered, are found still to retain almost all their characteristic markings. This substance has long been known by the designation of bituminous wood.

Wood of a very different character, called moss fir, is also frequently found in the peat mosses or bogs. It much resembles, in its color and general external appearance, ordinary decayed fir-wood; but on examination it appears that the fibre of the wood is strongly imbued with resin, and that all its interstices are filled with resinous matter. It is so highly inflammable as to be employed, by the poor of the districts in which it is found, not only as fuel, but as torches. As the real nature of this substance is not perhaps known, it would be very desirable that further enquiries might be made respecting it; it



might then be determined whether the opinion which is here offered be correct or not. From its retaining the color and appearance of decayed wood, it is conjectured to be wood which, by exposure to the atmosphere, had sustained the abstraction of all its constituent parts, except the resin and ligneous fibre impregnated therewith; and, from its having been thus rendered almost an entirely resinous mass, it has not been affected by the bituminising process. Subterranean collections of bituminised wood and other vegetable matter are found at various depths in different parts of the world. The substance thus found is generally a compact, light, glossy, combustible substance; of a dark brown color, and frequently almost black; splitting longitudinally into plates of various thicknesses, breaking transversely with an imperfect conchoidal fracture, with a shining resinous lustre, and sometimes yielding the appearance of the markings of wood. This is the suturbrand of Iceland, the Bovey coal of this country, and the common brown coal of Thomson.

The fossil wood, now described, may be said to pass into jet, which is found, especially in the neighbourhood of Whitby in Yorkshire, in a state very nearly approximating to that of Bovey coal. It exists in plates, generally from half an inch to about an inch in thickness, between which a film of carbonate of lime, with pyrites, is disposed: excepting that it more frequently shows marks of ligneous texture, its characters may be said to be those of jet; its color, velvet black; internal lustre, shining, resinous; fracture perfect, large, conchoidal; fragments, sharp edged, soft, rather brittle; easily frangible; very light. Jet is found in other situations, in a different form; resembling in its shape, and the markings of its surface, parts of the branches or trunks of trees, but rarely possessing, internally, any marks of vegetable origin; a circumstance easily accounted for, if its previous softening be admitted.

*Cannell coal* is said to differ from jet chiefly in its holding a greater portion of earth in intimate mixture with it. It never manifests internally any traces of vegetable structure, but sometimes bears on its surface evident marks of impressions formed on it whilst in a soft state.

*Common coal* is composed of a similar bituminous matter, divided by films of calcareous spar mingled with pyrites, intersecting each other nearly at right angles: its fracture is thus rendered small grained, and uneven, and its fragments mostly cubical or trapezoidal. By this division and enclosure of the inflammable bituminous matter in combustible septa, the ascension and combustion of this substance are rendered more slow, and better adapted to the purposes for which it is destined. Traces of vegetable structure are very rarely discoverable in coal, except in the impressions of cactuses and of various dorsiferous and succulent plants.

But professor Jameson, speaking of the coal found in the neighbourhood of Edinburgh, says, 'the coal, which is black coal, occurs in beds, seldom more than a few inches in thickness, and is generally contained in the bituminous shale or slate clay, rarely in the sandstone. By the gra-

dually increasing mixture of clayey matter, it passes into bituminous shale. The accompanying bituminous shale and slate clay contain impressions of ferns, a fact which has been adduced in support of the opinion which maintains the vegetable origin of black coal. We are inclined to call in question the supposed vegetable origin of this kind of coal, and are rather disposed to consider it as an original chemical formation; and that the occurrence of vegetable impressions in the adjacent rocks no more proves its vegetable origin, than the existence of fossil quadrupeds in the gypsum of Paris proves that rock to have been formed from the debris of animals of the class mammalia.

To these opinions it may be sufficient to oppose the following deductions of Dr. McCulloch, from his experiments on certain products obtained from the distillation of wood, &c. The Dr. considers himself as authorised to state that, 'examining the alteration produced by water on common turf, or submerged wood, we have all the evidence of demonstration that its action is sufficient to convert them into substances capable of yielding bitumen on distillation. That the same action having operated through a longer period has produced the change in the brown coal of Bovey is rendered extremely probable by the geognostic relations of that coal. From this to the harder lignites, suturbrand and jet, the transition is so gradual that there seems no reason to limit the power of water to produce the effect of bituminisation in all these varieties; nor is there aught in this change so dissonant from other chemical actions as to make us hesitate in adopting this cause.' Satisfied that jet, the bituminous lignite which approaches the nearest to coal in its chemical characters, is the result of the action of water on vegetable matter, Dr. McCulloch was induced to try if this substance could, by heat under pressure, be converted into coal; the result of his experiment was, that the produce exhibited the true characters of coal, having not merely the color and inflammability, but the fracture of coal and its odor on burning. These experiments and observations, taken with those of Mr. Hatchett, appear to be sufficient to set the question, as to the vegetable origin of coal, at rest. The vegetable origin of naphtha, petroleum, and asphaltum, is not yet positively ascertained.

Amber, from its being found generally in beds of fossil wood; the blue clay resin, found at Highgate and at Sheppey among the pyritified wood; and the retinasphaltum of Mr. Hatchett, discovered among the Bovey coal, may either owe their origin to the changes effected in vegetable matter during its subterraneous deposition, or may be vegetable resins, the original product of the trees which they accompany, and which, from their resinous nature, may have resisted the bituminizing process. The argillaceous ironstone nodules which accompany coal, contain, with the remains of many other unknown vegetables, parts of various cryptogamous plants, the recent analogues of a very few of which have been said to be found in some of the tropical regions. On these nodules being broken, the preserved remains are generally discovered on each

of the broken sides of the nodule; not, as might be expected, displaying different sides of the vegetable, but the same side of the leaf: for instance, on each broken surface; in one, in alto—in the other in basso relievo. The explanation of this curious circumstance, which long puzzled the oryctologists, is found in the vegetable matter, during its passing through the bituminous change, having become softened, and having filled its own mould with its melted and softened substance; the nodule, on being broken, showing on one side the surface of the adherent bituminous cast, and, on the other, the corresponding mould. In the argillaceous and bituminous slate forming the floors and roofs of coal mines are vast collections of the black bituminized remains of gramina, junci, cryptogami, and of numerous other plants, agreeing in their general characters with those of succulent plants, but differing from the recent ones known in Europe by their vast magnitude, and by the richness of the ornamental markings which appear on their trunks.

‘Description,’ says Mr. Parkinson, ‘cannot succeed in an attempt to give an idea of the beauty and varieties of the figures which are displayed on the surface of many of those fossils, and which have been supposed to owe their markings to the bark of different trees of supposed antediluvian existence. Some are ornamented by regularly disposed straight plain ribs, disposed longitudinally or transversely over their whole surface; some by the decussation of nearly straight lines obliquely disposed; and many by the alternate contact and receding of gently waving lines, forming areas regularly, but most singularly varying in their forms, and having in their centres tubercles and depressions from which spines, or setæ, have in all probability proceeded. In others, lines obliquely disposed intersect each other at angles, varying in their acuteness in different specimens, in, it would seem, an almost endless variety; forming surfaces apparently covered with squamæ disposed in an imbricated manner, and frequently in quin-cunx order.’

Accounts have been given of the trunks of trees whose cortical markings were entirely unknown, having been found in the sandstones of Staffordshire, Derbyshire, Lancashire, and indeed in all those parts in which the coal formations have been explored. Having been favored, says Mr. Parkinson, with the opportunity of examining several specimens of this nature, through the kindness of Thomas Botfield, esq., of Bewdley in Worcestershire, I am enabled to say that these are not generally the remains of trees, but of succulent plants, the firm cortical parts of which, having been converted by the bituminating process into jet, have formed that firm tube which is often found, in these instances, filled with sandstone, agreeing with that of the general matrix, and possessing the space left by the waste of the internal succulent part of the plant. The description of the last announced fossil of this kind, found in the neighbourhood of Glasgow, agrees exactly with the general account of these supposed fossil trees, and will, it is presumed, corroborate the opinion which has

been just advanced. In a quarry of sandstone belonging to the coal formation on which Glasgow is built, and in the neighbourhood of that city, it is stated that ‘the quarrymen came upon the cast of a tree in situ just as it had been growing. The trunk is about twenty-six inches in diameter, not quite round but somewhat oval, so that the north and south diameter is several inches longer than the east and west diameter. The body of the tree itself is composed of sandstone precisely similar to the rest of the quarry; but the bark has been converted into perfect cherry coal, which adheres firmly to the tree, and renders it easy to remove the rock with which it is incrustated. About three feet of the bottom part of the tree has been uncovered; this portion is situated about forty feet below the surface of the earth in a solid quarry of sandstone. The upper part of the trunk and branches has not been discovered: indeed, it is some time since the upper portion of the quarry was removed. The roots may be seen dipping down into the earth precisely as the roots of living trees do. Four very large roots may be seen issuing from the trunks, and extending, some of them, about a foot before they are lost in the surrounding stone. There is nothing to indicate the species of tree of which the mould has been here preserved. From the appearance of the roots it is obvious that it was not a fir; it had more resemblance to a beech: the bark has been so completely bituminised, that its usual characters are effaced. The petrification, however, is not without its value; it demonstrates that the sandstone has been formed at a period posterior to the existence of large trees, and that the water-worn appearance of the quartz pebbles of which the sandstone is composed is not a deceitful indication.’ Hence the ingenious observer is led to observe, that ‘if the sandstone, which constitutes so great a proportion of the coal beds, be a formation posterior to the earth being covered with wood, we can entertain no doubt that this is the case also with the slate clay and the coal which alternate with this sandstone. Indeed, if the coal formation exists as a portion of the old red sandstone, we can entertain no reasonable doubt that the old red sandstone itself has been formed after the earth was covered with wood.’ *Annals of Philosophy*, Nov. 1820.

‘The size which these fossil plants have attained, compared with that of the cactuses known in Europe, must, as in the fossil last mentioned, lead to a doubt as to this opinion of their agreement with the recent cactus. But, to be enabled to form a correct judgment on this point, it is necessary to know the state in which these plants exist where the soil and climate are such as to allow them to develop themselves in their native luxuriance. The researches of the celebrated Humboldt, in the equinoctial regions, supply us on this head with the most appropriate and satisfactory information. The following detached observations of that philosopher will show not only the size to which these plants may arrive, but the vast tracts which, under favorable circumstances, they may overrun, as well as the great probability of their having been the first vegetable clothing of the earth. ‘The hill of calcareous

breccia, which we have just regarded as an island in the ancient gulph, is covered with a thick forest of columnar cactus and opuntia, some thirty or forty feet high, covered with lichens, and divided into several branches in the form of candelabras, wearing a singular appearance. Near Maniquarez, and Punta Araya, we measured a cactus, the trunk of which was four feet nine inches in circumference. The European, acquainted only with the opuntia in our hot-houses, is surprised to see the wood of this plant become so hard from age, that it resists for centuries both air and water, and that the Indians of Cumana employ it in preference for hords and doorposts. Cumana, Coro, the island of Margareta, and Curacao, are the places in South America that abound most in the plants of the family of the nopals. There, only, a botanist can compose a monography of the genus cactus, the species of which vary not only in their flowers and fruits, but in the form of their articulated stem, the number of costæ, and the disposition of the thorns: the divisions of property are marked by hedges formed of the agave and cactus. At San Fernando, S. A., the soil abounds in aquatic plants with sagittate leaves, and he remarks that some of these succulent plants are from eight to ten feet high. In Europe their assemblage would be considered a little wood.' He also mentions a kind of bamboo which the Indians call jagua, which is found near San Fernando, more than forty feet in height. These, he observes, cannot but remind the admirer of fossils of the vast fossil bamboos which are found in the sandstones accompanying coal. Speaking of a rock of considerable height and magnitude, he observes, 'Euphorbium, calalia, kleinia, and cactus, which are become wald in the Canary Islands, as well as in the south of Europe and the whole continent of Africa, are the only plants we see on this arid rock, being plants which draw their nourishment rather from the air than from the soil in which they grow.' He also remarks, 'it is not, in general, by mosses and lichens that vegetation in the countries near the tropics begins. In the Canary Islands, as well as in Guinea and in the rocky coasts of Peru, the first vegetables that prepare the mould for others are the succulent plants.'

We now follow Mr. Parkinson's description of I. CALCAREOUS VEGETABLE FOSSILS.—Lime is not very frequently the mineralising matter of vegetable fossils; it is however sometimes found introduced into the remains of wood in the form of spar, and sometimes it becomes, in the form of limestone, the internal substance of fossil reefs and of various succulent plants.

1. *Calcareous spathose wood previously decayed*.—Color light brown, surface rough and dull, but susceptible of polish; fracture dull, uneven, and rather spicular; interstices filled with nearly colorless spar. The line being removed from this fossil, by muriatic acid, a considerable portion of light-colored flocculent substance is deposited. Found in alluvia and in the oolite formation.

2. *Calcareous spathose wood previously bituminous*.—Color darkish red brown; surface commonly rough, but partially glossy; fracture dull,

uneven, and rather spicular, veined with spar of a lightish brown color. Found in the clay of bituminous slate accompanying the lias. The lime being removed, by the muriatic acid, a considerable volume of dark brown powder remains, which, when dried, is remarkably combustible, burning with a flame resembling that of some of the pyrophori. On the brown spar being subjected to the action of diluted muriatic acid, the bituminous matter with which it is colored rises in a film to the surface of the solution. The polished surface of both these fossils being examined with a lens, the spathose substance is seen to have permeated the minutest woody fibres in all their directions. The powder deposited during the solution of both these fossils is undoubtedly the woody fibre reduced to this state of minute division, in consequence of its penetration in every direction by the spathose crystallisation.

II. SILICEOUS VEGETABLE FOSSILS.—The mineralisation of vegetable substances is most frequently effected by those impregnations in which siliceous is the principal constituent; the fossils thus formed being remarkable for the correctness with which their forms and markings have been preserved.

1. *Siliceous wood*.—Its color is generally grayish and yellowish white, thence passing into ash gray, grayish black, and different shades of brown. Its internal lustre is glistening, its fracture more or less perfect conchoidal, showing the ligneous texture. The fragments sharp-edged and translucent. It is harder than opal, and easily frangible.

It is found in many parts of the world, but some of the finest specimens are obtained in the neighbourhood of Schemnitz and at Telkabanya in Hungary.

It is frequently found in this island in the diluvian detritus, and in almost the whole of the green sand formation. Very large fragments are found in the Portland stones, the interstices of which are often beautifully sprinkled with quartz crystals. Interesting specimens are also discovered in the gritstone of the same formation in the blackdown pits of Devonshire, which are frequently rendered very interesting by the delicate amianthine form in which the siliceous is disposed. Specimens are also found in the sands of Bedfordshire. It is but rarely found in chalk; it however forms the nucleus of a flint nodule which is said to have been obtained in Berkshire.

The varieties of siliceous wood depend not only on the nature of the combinations forming the lapideous matter of which it is chiefly constituted, but also, as has been already observed, on the state of the wood previous to its petrification. When the fossil is light colored, and of a shivery texture, the wood may be presumed to have been previously in a decayed state, or, as it is termed, rotten wood; and when close, compact, and dark-colored, it may have suffered previous bituminisation.

A. *Chalcheldonic wood*.—In the most common form in which this variety appears, the color is of a yellowish-white, the substance resembling that of withered wood. The surface rough and

splintery, the splinters frequently so minute as to be wafted with the slightest breath. The internal part solid, chiefly formed of the translucent siliceous matter, which fills the interstices and such cavities as may have been formed by the teredines and other insects, and also sometimes invests the ends of the specimen in a mammillated or stalagmitic form. Specimens occur in which previous bituminisation also appears to have taken place, and in which the clear siliceous substance appears as if it had transuded into the cavities, and had exuded at the ends of the specimens. Hither must be referred those amorphous specimens which possess a rough surface, scarcely any lustre, with patches of apple-green color and of a quartzose hardness, intermixed with others of a light or light gray color, considerably softer. When cut and polished, the white parts display evident marks of vegetable texture; either that of very fine grained woods, or of some of the palms or reeds, the spaces between being filled with siliceous matter, either translucent or of an apple-green color.

B. *Jasperine wood* displays all the colors and appearances belonging to common jasper, so disposed as to mark the existence of ligneous texture, and frequently so varied as to give the resemblance of different woods. It is usually opaque, but sometimes translucent at the edges, and sometimes in patches, where it appears as jasper agate. Its fracture passes from conchoidal to flat and earthy; its internal lustre is generally dull, but sometimes approaching to resinous; its interstices are frequently set with minute crystals. The texture of the wood is discoverable in some very rare specimens of heliotrope, or bloodstone.

C. *Opaline wood* occurs in pieces of a yellowish or yellowish-white color, passing into different shades of brown: surface generally marked by the ligneous structure, and possessing a resinous lustre. The fracture more or less approaching to perfect conchoidal, showing the ligneous marking and a glistening lustre. Fragments sharp-edged, and somewhat translucent: the surface sometimes dull, like wood, and the internal substance transparent. It is considered by Dr. Thomson as consisting of wood penetrated by opal, and as being so intimately connected with opal that it would perhaps be better to unite them.

D. *Pitchstone wood*.—Specimens of fossil wood, evidently showing its original texture, and answering to the characters of pitchstone, are frequently seen: its colors are yellow, brown, reddish brown, red, black, white, and gray, with various intermediate shades; fracture is flattish, imperfectly large conchoidal; lustre varying between dull, vitreous, and resinous. The woody texture is to be traced also in numerous lapideous substances bearing the intermingled characters of pitchstone, opal, jasper, chalcedony, jasper-agate, &c.

### III. ALUMINOUS VEGETABLE FOSSILS.

1. *Bituminous slate, schistus, and shale, containing vegetable remains*, are frequently met with in the neighbourhood of coal. These remains, as have been already mentioned, are of various gramina, cryptogami, and succulent plants. On allowing some of these bodies to remain in water,

their substance becomes softened down, and is resolved into a mass in which the vegetable matter is obvious.

2. *Aluminous wood*.—The wood which has been thus named by different authors, by its proneness to combustion, and by the other properties which they describe it to possess, should be considered as pyritous wood, having obtained its change in the ferruginous clay in which it has been imbedded. The mineralising matter of metallic fossil vegetables is most commonly the pyrites or sulphurets and carbonates of iron, copper, zinc, or lead.

#### I. FERRUGINOUS FOSSIL WOOD.

1. *Pyritical*.—In this fossil the sulphuret of iron pervades the charcoal into which the vegetable matter has been converted. When first found it generally possesses metallic brilliancy, is sufficiently hard to scratch glass, emits sparks on collision with steel, and displays the forms and markings pointing out its vegetable origin; but it soon begins to suffer from decomposition, when its characters change, and it finally resolves into a saline flocculent substance.

2. *Carbonated*.—In these specimens, which are of different shades of brown color, and generally of a uniform substance, the marks of the vegetable origin are easily observable, although not so distinct as in the specimens of the preceding species before the commencement of the decomposition.

#### II. FERRUGINOUS FOSSIL SEEDS, &c.

Innumerable seeds, seed-vessels, &c., have been found by Mr. Crow and others, in the blue clay of Sheppey in the state of pyrites. Most of these belong to plants unknown to our botanists; the existing plants, to which the others seem to approximate, are some of those of the warmer climates.

#### III. CUPREOUS FOSSIL WOOD.

1. *Pyritical*.—This fossil is distinguishable from the ferruginous pyritical wood, by the pyrites being of rather a darker color, but chiefly by the blue, or green color which partially pervades the fossil. In some specimens, in which the general appearance is that of bituminous wood, the metallic impregnation can only be detected by the weight of the fossil and the blue or green hue on its surface.

2. *Wood converted into carbonate and hydrate of copper*.—Cupreous wood in this state forms very beautiful specimens, displaying, not only on its surface, but in its substance, mingled with the charred wood, the most vivid blue and green colors, with patches of the carbonate in the state of malachite. The finest specimens of cupreous wood are obtained from the copper mines of Siberia.

3. *Wood mineralised by lead*.—Specimens of wood containing galena, the sulphuret of lead, have been chiefly discovered in Derbyshire. The leaves of plants, except those of gramina, junci, and of the cryptogamia, are seldom found in a mineralised state. The lobes and pinnulæ of ferns, as has been before mentioned, are frequently found in a bituminised state in nodules of ironstone, and in immense quantities with the remains of gramina and succulent plants in the schistose and slaty coverings of coal.

Among the numerous remains of plants very few are found which agree in their specific characters with any known species, and many indeed differ so much as to render it difficult to determine even the genus under which they should be placed. The leaves of trees are only found in substances which appear to be of modern formation. Among these are said to have been found those of the willow, the pear-tree, mulberry-tree, and of several others. These have been found in fossil calcareous stone, chiefly in that of Oeningen, and in the calcareous tufa bordering those lakes and rivers which abound in calcareous matter. Leaves are sometimes found in sandstone which somewhat resemble those of trees, but which most probably have belonged to aquatic plants. In the gray chalk, small white ramose forms are found, which pervade the chalk, and have the appearance of being of vegetable origin. Wood and other vegetable substances are frequently found in clay and limestone in the state of charcoal. It cannot always be ascertained by what means this change has been effected; but in that which is found in the blue clay, and in other situations in which pyrites prevail, the change may safely be attributed to the decomposition of the pyrites with which those substances had been impregnated.

*Mosses, Conifers, &c.*—Rounded pebbles, called moss agates, are frequently found on the coast of the North Riding of Yorkshire: and Dr. M'Culloch describes them as having been found on the shore at Duglas in Scotland, containing substances which have the appearance of vegetables.

Daubenton and Blumenbach had expressed their conviction of the vegetable origin of these substances; still many considered them as entirely mineral: but Dr. M'Culloch, pursuing this enquiry with his usual zeal and acuteness, observes, that deception is very likely to arise in these specimens, from the well known metallic arborizations emulating the vegetable forms, becoming blended with the real vegetable; and from the actual investment of the whole plant with carbonate of iron; but the most common source of deception and obscurity, in the Dr.'s opinion, 'will be found in the whimsical and fibrous disposition occasionally assumed by chlorite, its color often imitating the natural hue of a plant as perfectly as its fibrous and ramified appearance does the disposition and form of one.' All the plants that have been discovered in this state of envelopment in quartz appear to belong to certain species of the cryptogamia class, chiefly byssi, confervæ, jungermanniæ, and the mosses. The stones found at Duglas, Dr. M'Culloch observes, 'contain remains of organized substances of an epocha at least equally ancient with that in which the vegetable remains found in the floetz strata existed. As the species ascertained by Daubenton have, in all probability, been preserved in recent formations of chalcedony,' so the Dr. thinks that 'those which he describes have been preserved in the chalcedonies of former days.' The moss agates of the Yorkshire coast appear to be of the ancient, whilst other specimens prove the correctness of Dr. M'Culloch's opinion, that some of these fossils are of recent formation.

The remarks of Dr. M'Culloch on the mode in which these curious investments were accomplished, deserve particular attention:—'The remains are, in fact (if I may use such an expression), embalmed alive. To produce this effect, we can only conceive a solution of silicic acid in water, so dense as to support the weight of the substance involved, a solution capable of solidifying in a short space of time, or capable at least of suddenly gelatinizing previously to the ultimate change by which it became solidified into stone.' Dr. M'Culloch describes and figures a series of tubuli contained in an oriental agate: similar substances are found in the pebbles on the Yorkshire coast.

A knowledge of the vegetable fossils peculiar to the different strata will, in all probability, open to us considerable stores of instruction; we may thereby learn, not only the nature of the several vegetable beings of the earlier ages of this planet, but may ascertain the order in which the several tribes were created: and, reckoning upon the considerable advance which has been made in our knowledge of the structure of the earth, and upon the eagerness with which enquiries respecting the organic remains of former periods are pursued, the attainment of such knowledge, it may be presumed, is not far distant. At present we know of no vegetable remains of earlier formation; and these appear to be chiefly derived from various grasses and reeds, and plants of the cryptogamous and succulent tribes, many of which are not known to exist on the surface of the earth at present. From the latter of these the coal itself appears to have chiefly proceeded. In the mountain limestone above the coal, and in the different members of this formation existing between this and the blue lias, vegetable remains appear to be of but rare occurrence; so that particulars of such as have been discovered in these situations may furnish much useful information, and especially with respect to those fossils which are supposed to have derived their origin from wood.

It has been assumed that wood, or parts of trees, have been found in coal and in the accompanying coal-measures, but some confirmation of these accounts seems to be required. The description of these fossils has seldom been so particular and exact as to yield positive evidence of their original nature; and, as has been already shown, the instances are by no means infrequent in which the traces, and even the remains, of cactuses and other succulent plants, had given rise to the belief of the existence of fossil trees in these strata. This opinion may therefore have obtained seeming confirmation from the lincous hardness which large plants of this kind might have acquired, and which, perhaps, might be traced in their mineralised remains. The earliest stratification in which fossil wood exists is not perhaps at present determined; but it seems that the earliest appearance in this island of fossil wood, which by its uniformity of character appears to belong to a particular bed, is the spathose bituminous wood of the blue lias, as found at Lyme in Dorsetshire, and in the neighbourhood of Bath. In the next formation, and

particularly in that of the green sand, siliceous fossil wood occurs frequently. Very delicate specimens are found in the sandstone, the whetstone of the Blackdown hills of Devonshire. The specimens of fossil wood found in the Portland stone are frequently of very considerable size, and bear all the characteristic marks of wood: these are also siliceous, and are often beautifully sprinkled on their interior surfaces with quartz crystals. Siliceous fossil wood is also found in other situations, as in the sands of Wooburn in Bedfordshire: it also occurs at Folkstone in Kent, in that part of the green sand where it approximates to the superincumbent marl, in which it is also found. Traces of wood are hardly ever discovered in the chalk itself, and so rarely in the accompanying flint nodules, that the knowledge of but one specimen, an instance of this occurrence, is known to the writer of these pages. But in the blue clay, incumbent upon this immense accumulation of chalk, fossil wood, pierced with teredines, and impregnated with calcareous spar, is exceedingly abundant: and in almost every sunken part of this bed, and even of the whole surface of this island, the remains are discoverable of vast forests which have suffered little other change than that of having undergone different degrees of bituminisation.

By these facts, concludes Mr. Parkinson, we learn that, at some very remote and early period of the existence of this planet, it must have abounded with plants of the succulent kind, and, as it appears from their remains, in great variety of form and luxuriance of size. These, from what is discoverable of their structure, beset with setæ and spines, were not formed for the food of animals; nor, from the nature of the substances of which they were composed, were they fitted to be applied to the various purposes to which wood, the product of the earth at a subsequent period, has been found to be so excellently adapted, by man. Their remains, it must also be remarked, are now found in conjunction with that substance which nature has, in all probability, formed from them; and which, by the peculiar economical modification of its combustibility, is rendered an invaluable article of fuel. If this be admitted to be the origin of coal, a satisfactory cause will appear for the vast abundance of vegetable matter with which the earth must have been stored in its early ages: this vast, and in any other view useless, creation, will thus be ascertained to have been a beneficent arrangement by Providence for man, the being of a creation of a later period.

#### CLASS IX.—HOMO.

Remains of the *human species* are not found in secondary strata; but in the clay of the fissures of rocks they are not infrequent, and they have been found in alluvial soil at Köestretz in Germany. Mr. König's account of the most celebrated fossile skeleton yet discovered (and which is now in the British Museum) is thus introduced:—

'All the circumstances under which the known depositions of bones occur,' says this gentleman, 'both in alluvial beds and in the caverns and fissures of flötz limestone tend to prove, that

the animals to which they belonged met their fate in the very places where they now lie buried. Hence it may be considered as an axiom, that man, and other animals, whose bones are not found intermixed with them, did not co-exist in time and place. The same mode of reasoning would further justify us in the conclusion, that, if those catastrophes which overwhelmed a great proportion of the brute creation were general, as geognostic observations in various parts of the world render probable, the creation of man must have been posterior to that of those genera and species of mammalia which perished by a general cataclysm, and whose bones are so thickly disseminated in the more recent formations of rocks.

'The human skeletons from Guadaloupe are called Galibi by the natives of that island; a name said to have been that of an ancient tribe of Caribs of Guiana, but which, according to a plausible conjecture, originated in the substitution of the letter *l* instead of *r*, in the word Caribbee. No mention is made of them by any author except general Ernouf, in a letter to M. Faujas St. Fond, inserted in vol. v. 1805 of the *Annales du Muséum*; and by M. Lavoisier, in his *Voyage à la Trinidad, &c.*, published in 1813. The former of these gentlemen writes, that, on that part of the windward side of the Grande-Terre called La Moule, skeletons are found enveloped in what he terms 'Masses de madrépores pétrifiées,' which being very hard, and situated within the line of high water, could not be worked without great difficulty, but that he expected to succeed in causing some of these masses to be detached, the measurements of which he states to be about eight feet by two and a half.

'The block brought home by Sir Alexander Cochrane exactly answered this account with regard to the measurements; in thickness it was about a foot and a half. It weighed nearly two tons; its shape was irregular, approaching to a flattened oval, with here and there some concavities, the largest of which, as it afterwards appeared, occupying the place where the thigh bone had been situated, the lower part of which was therefore wanting. Except the few holes evidently made to assist in raising the block, the masons here declared, that there was no mark of a tool upon any part of it; and, indeed, the whole had very much the appearance of a huge nodule disengaged from a surrounding mass. The situation of the skeleton in the block was so superficial, that its presence in the rock on the coast had probably been indicated by the projection of some of the more elevated parts of the left fore-arm.

'The skull is wanting; a circumstance which is the more to be regretted as this characteristic part might possibly have thrown some light on the subject under consideration, or would, at least, have settled the question, whether the skeleton is that of a Carib, who used to give the frontal bone of the head a particular shape by compression; which had the effect of depressing the upper, and protruding the lower edge of the orbits, so as to make the direction of their opening nearly upwards, or horizontal, instead

of vertical. The vertebræ of the neck were lost with the head. The bones of the thorax bear all the marks of considerable concussion, and are completely dislocated. The seven true ribs of the left side, though their heads are not in connexion with the vertebræ, are complete; but only three of the false ribs are observable. On the right side only fragments of these bones are seen; but the upper part of the seven true ribs of this side are found on the left, and might at first sight be taken for the termination of the left ribs. The right ribs must therefore have been violently broken, and carried over to the left side, where, if this mode of viewing the subject be correct, the sternum must likewise lie concealed below the termination of the ribs. The small bone dependent above the upper ribs of the left side appears to be the right clavicle. The right os humeri is lost; of the left nothing remains except the condyles in connexion with the fore-arm, which is in the state of pronation; the radius of this side exists nearly in its full length, while of the ulna the lower part only remains, which is considerably pushed upwards. Of the two bones of the right fore-arm the inferior terminations are seen. Both the rows of the bones of the wrists are lost, but the whole metacarpus of the left hand is displayed, together with part of the bones of the fingers: the first joint of the fore finger rests on the upper ridge of the os pubis, the two others, detached from their metacarpal bones, are propelled downwards, and situated at the inner side of the femur, and below the foramen magnum ischii of this side. Vestiges of three of the fingers of the right hand are likewise visible, considerably below the lower portion of the fore-arm, and close to the upper extremity of the femur. The vertebræ may be traced along the whole length of the column, but are in no part of it well defined. Of the os sacrum the superior portion only is distinct: it is disunited from the last vertebra and the ilium, and driven upwards. The left os ilium is nearly complete; but shattered, and one of the fragments depressed below the level of the rest: the ossa pubis, though well defined, are gradually lost in the mass of the stone. On the right side the os innominatum is completely shattered, and the fragments are sunk; but, towards the acetabulum, part of its internal cellular structure is discernible.

‘The thigh bones and the bones of the leg of the right side are in good preservation, but, being considerably turned outwards, the fibula lies buried in the stone, and is not seen. The lower part of the femur of this side is indicated only by a bony outline, and appears to have been distended by the compact limestone that fills the cavities both of the bones of the leg and thigh, and to the expansion of which these bones probably owe their present shattered condition. The lower end of the left thigh bone appears to have been broken and lost in the operation of detaching the block; the two bones of the leg, however, on this side are nearly complete: the tibia was split almost the whole of its length a little below the external edge, and the fissure, being filled up with limestone, now presents

itself as a dark colored straight line. The portion of the stone which contained part of the bones of the tarsus and metatarsus was unfortunately broken; but the separate fragments are preserved.

‘The whole of the bones, when first laid bare, had a mouldering appearance, and the hard surrounding stone could not be detached, without frequently injuring their surface; but, after an exposure for some days to the air, they acquired a considerable degree of hardness. Sir H. Davy, who subjected a small portion of them to chemical analysis, found that they contained part of their animal matter, and all their phosphate of lime. Here follows an exact description of the rock, in which the fossile skeleton is found. The attention of geologists being now directed towards this object, it may be expected that a scientific examination of the circumstances under which this limestone occurs will not fail ere long to fix its age, and assign to it the place it is to occupy in the series of rocks. All our present information respecting the Grande Terre of Guadaloupe amounts to this, that it is a flat limestone country, derived principally from the detritus of zoophytes, with here and there single hills (mornes) composed of shell limestone; while Guadaloupe, properly so called, separated from the upper part by a narrow channel of the sea, has no traces of limestone, and is entirely volcanic.’ See plate II. fig. 3.

Since the above has been prepared we have happened of the accounts of an old acquaintance, Mr. Trimmer, of some organic remains found near Brentford, Middlesex; the spot mentioned will be familiar to many of our readers. He is describing in order the remains of two fields, not contiguous.

‘The first,’ he says, ‘is about half a mile north of the Thames at Kew Bridge; its surface is about twenty-five feet above the Thames at low water. The strata here are, first, sandy loam from six to seven feet, the lowest two feet slightly calcareous. Secondly, sandy gravel, a few inches only in thickness. Thirdly, loam slightly calcareous, from one to five feet: between this and the next stratum peat frequently intervenes in small patches, of only a few yards wide and a few inches thick. Fourthly, gravel containing water; this stratum varies from two to ten feet in thickness, and is always the deepest in the places covered by peat; in these places the lower part of the stratum becomes an heterogeneous mass of clay, sand, and gravel, and frequently exhales a disagreeable muddy smell. Fifthly, the main stratum of blue clay, which lies under this, extends under London and its vicinity; the average depth of this clay has been ascertained, by wells that have been dug through it, to be about 200 feet under the surface of the more level lands, and proportionally deeper under the hills, as appears from lord Spencer’s well, at Wimbledon, which is 567 feet deep. This stratum, besides figured fossils, contains pyrites and many detached nodules; at the depth of twenty feet there is a regular stratum of these nodules, some of which are of very considerable size.

‘In the first stratum, as far as my observation

has extended, no remains of an organised body has ever been found, and, as my search has not been very limited, I may venture to say it contains none. In the second stratum snail shells, and the shells of river fish have been found, and a few bones of land animals, but of inconsiderable size, and in such a mutilated state that it cannot be ascertained to what class they belong. In the third stratum the horns and bones of the ox, and the horns, bones, and teeth of the deer, have been found, and also, as in the second stratum, snail shells, and the shells of river fish. In the fourth stratum were found teeth and bones of both the African and Asiatic elephants, teeth of the hippopotamus, bones, horns, and teeth of the ox. A tusk of an elephant measured, as it lay on the ground, nine feet three inches, but, in attempting to remove it, it broke into small pieces. When this stratum dips into the clay, and becomes a mixed mass, as before stated, it is seldom without the remains of animals. In the fifth stratum, namely, the blue clay, the extraneous fossils are entirely marine, with the exception of some specimens of fruit and pieces of petrified wood, the latter of which may be considered as marine, because, when of sufficient size, they are always penetrated by terebines. The other fossils from this stratum are nautili, oysters, *pinnae marinæ*, crabs, teeth and bones of fish, and a great variety of small marine shells; this stratum has been penetrated hitherto in this field only to the depth of thirty feet, throughout which the specimens found were dispersed without any regularity.

The second field is about one mile to the westward of the former, one mile north of the Thames, and a quarter of a mile to the eastward of the river Brent; its height above the Thames at low water is about forty feet. The strata are, first, sandy loam, eight or nine feet, in the lowest three feet of which it is slightly calcareous. Secondly, sand, becoming coarser towards the lowest part, and ending in sandy gravel from three to eight feet. Thirdly, sandy loam highly calcareous, having its upper surface nearly level, but gradually increasing in thickness, from a feather-edge to nine feet. Below this are two strata of gravel and clay, as in the other field; but, as these strata have been only occasionally penetrated in digging for water, nothing therefore is known with respect to them but that they exist there. In the first stratum, as in the other field, no organic remains have been observed. In the second, but always within two feet of the third stratum, have been found the teeth and bones of the hippopotamus, the teeth and bones of the elephant, the horns, bones, and teeth of several species of deer, the horns, bones, and teeth of the ox, and the shells of river fish.

The remains of hippopotami are so extremely abundant, that, in turning over an area of 120 yards in the present season, parts of six tusks have been found of this animal, besides a tooth and part of the horn of a deer, part of a tusk, and part of a grinder of an elephant, and the horns, with a small part of the skull, of an ox. One of these horns I had an opportunity of measuring as it lay on the ground, and found it to be four feet and a half in length, and five

inches in diameter at the large end; it was found impracticable to move it otherwise than in fragments, which I have preserved, and have hopes of being able to put a considerable part of it together. The immense size of this horn is rendered more remarkable by another horn from the same spot, which measures but six inches in length. Though this stratum is so extremely productive of the remains of animals, yet there are but few good cabinet specimens from it, owing, it is presumed, to their having been crushed at the time they were buried, and to the injury they have since received from moisture. It is necessary to remark that the gravel-stones in this stratum do not appear to have been rounded in the usual way by attrition, and that the bones must have been deposited after the flesh was off, because, in no instance have two bones been found together which were joined in the living animal; and further, that the bones are not in the least worn, as must have been the case had they been exposed to the wash of a sea-beach.

In the third stratum, viz. calcareous loam, have been found the horns, bones, and teeth of the deer, the bones and teeth of the ox, together with snail-shells, and the shells of river-fish.

Brentford, in the neighbourhood of which are the fields I have mentioned, is situated on the north bank of the Thames, and is six miles west of London. The fall of the Thames from Brentford to its mouth at the Nore is estimated at seven feet.—*Philosophical Transactions*.

We close with a late ingenious speculation of baron Humboldt's on the occurrence of tropical animals and plants, in a fossile state, in the frozen regions of the earth.

Speaking of the heat of the body of our planet he says, 'It is perhaps in the internal heat of the earth, a heat which is indicated by experiments made with the thermometer, and the phenomena of volcanoes, that the cause of one of the most astonishing phenomena which the knowledge of petrifications presents to us resides. Tropical forms of animals, arborescent ferns, palms and bamboos, occur imbedded in the frozen regions of the north. The primitive world every where discloses to us a distribution of organic forms, which is in opposition to the presently existing state of climates. To solve so important a problem, recourse has been had to a great number of hypotheses, such as the approach of a comet, the change of obliquity of the ecliptic, the increase of intensity of the solar heat. None of these hypotheses has been able to satisfy at the same time the astronomer, the natural philosopher, and the geologist. As to my own opinion on the subject, I leave the earth's axis in its position, I admit no change in the radiation of the solar disk, a change by which a celebrated astronomer thought he could explain the good and bad harvests of our fields; but I imagine that in each planet, independently of its relations to a central body, and independently of its astronomical position, there exist numerous causes of development of heat, whether by the chemical processes of oxidation, or by the precipitation and changes of capacity of bodies, or by the augmentation of the electro-magnetic



intensity, or the communication between the internal and external parts of the globe.

‘When, in the primitive world, the deeply fissured crust of the earth exhaled heat by these apertures, perhaps during many centuries, palms, arborescent ferns, and the animals of warm climates, lived in vast expanses of country. According to this system of things, which I have already indicated in my work entitled *Essai Geognostique sur le Gisement des Roches dans les deux Hemispheres*, the temperature of volcanoes is the same as that of the interior of the earth, and the same cause which now produces such frightful ravages would formerly have made the richest vegetation to spring in every zone, from the newly oxidised envelope of the earth, and from the deeply fissured strata of rocks. If, in order to account for the distribution of the tropical forms that occur buried in

the northern regions of the globe, it is assumed that elephants covered with long hair, now immersed in the polar ice, were originally natives of those climates, and that forms resembling the same principal type, such as that of lions and lynxes, may have lived at the same time in very different climates, such a mode of explanation would yet be inapplicable to the vegetable productions. For reasons which vegetable physiology discloses, palms, bananas, and arborescent monocotyledonous plants, are unable to support the cold of the northern countries; and, in the geognostical problem which we are here examining, it appears to me difficult to separate the plants from the animals; the same explanation ought to embrace the two forms.’ (*Tableaux de la Nature*), as quoted in the *Edinburgh Philosophical Journal*, September, 1828.

**REMAKE**, *v. a.* Re and make. To make anew.

That, which she owns above her, must perfectly remake us after the image of our maker. *Glanville.*

**REMAND**. *Lat. re* and *mando*. To send back; call back.

The better sort quitted their freeholds and fled into England, and never returned, though many laws were made to *remand* them back. *Davies.*

Philoxenus, for despising some dull poetry of Dionysius, was condemned to dig in the quarries; from whence being *remanded*, at his return Dionysius produced some other of his verses, which as soon as Philoxenus had read, he made no reply, but, calling to the waiters, said, Carry me again to the quarries. *Government of the Tongue.*

**REM'ANENT**, *n. s.* Old Fr. *remanant*; *Lat. remanens*. Now contracted to remnant. The part remaining.

Her majesty bought of his executrix the *remanent* of the last term of three years. *Bacon.*

**REMARK**, *v. a. & n. s.* } *Fr. remarquer*, or  
**REMARK'ABLE**, *adj.* } perhaps re and mark.  
**REMARK'ABLENESS**, *n. s.* } To note; observe  
**REMARK'ABLY**, *adv.* } particularly; distinguish:  
**REMARK'ER**, *n. s.* } the note or observation made or taken: remarkable is, worthy of note; observable: the noun substantive and adverb corresponding: remarker, an observer.

So did Orpheus plainly teach that the world had beginning in time, from the will of the most high God, whose *remarkable* words are thus converted.

*Raleigh.*  
 They signify the *remarkableness* of this punishment of the Jews, as signal revenge from the crucified Christ. *Hammond.*

The prisoner Samson here I seek.  
 —His manacles *remark* him, there he sits. *Milton.*  
 It is easy to observe what has been *remarked*, that the names of simple ideas are the least liable to mistakes. *Locke.*

'Tis *remarkable* that they  
 Talk most who have the least to say. *Prior.*  
 He cannot distinguish difficult and noble speculations from trifling and vulgar *remarks*. *Collier.*

Such parts of these writings as may be *remarkably* stupid should become subjects of an occasional criticism. *Watts.*

If the *remarker* would but once try to outshine the author, by writing a better book on the same subject, he would soon be convinced of his own insufficiency. *Id.*

**REMBANG**, a large town on the north coast of Java, containing many good houses, and advantageously situated close to the sea, which washes the walls of a fort. Formerly the Dutch built their principal vessels and kept a considerable garrison here. A quantity of sea salt is produced in the neighbourhood.

**REMBRANDT** (Van Ryn). This celebrated painter was the son of a miller, and was born at a village near Leyden in 1606. He obtained the name of Van Ryn, from his having spent the youthful part of his life on the borders of the Rhine. He was at first placed under Jacob Van Zwanenburg, with whom he continued three years; and after this studied under Peter Lastman, with whom, however, he staid only six months. For the same length of time he was the scholar of Jacob Pinas; from whom he acquired that taste for strong contrasts of light and shadow which he ever after so happily cultivated. He, however, formed his own style entirely, by studying and imitating nature, and his amazing power in representing every object with truth, force, and life, has never since been equalled. By the advice of a friend, Rembrandt was prevailed on to carry one of his early performances to the Hague; where a dealer instantly gave him 100 florins for the picture. This incident not only served to make the public acquainted with his abilities, but contributed to make him more sensible of his own talents. He soon after this settled in Amsterdam, that he might follow his profession with more advantage. Business crowded on him immediately, so as scarcely to allow him time to gratify the demand for his paintings; and he had such a number of pupils that wealth flowed in plentifully. He received from each of his scholars 100 florins a-year for their instruction; and he also raised a considerable sum by the sale of the copies they made after his pictures and designs; which he always retouched in several parts, to increase their value, and to make purchasers believe them his own. By this traffic, and an artful manage

ment of the sale of his etchings, he gained at least every year 2500 florins. His style of painting, in the first years of his practice, was very different from that of his latter time; his early performances being highly finished, with a neat pencil, resembling those of Hieris; while his latter style of coloring and handling was strong, bold, and with a degree of force, in which he has not been excelled by any artist; a picture of his maid servant, placed at the window of his house in Amsterdam, is said to have deceived the passengers for several days. De Piles, when he was in Holland, not only ascertained the truth of this fact, but purchased the portrait, which he esteemed one of the finest ornaments in his cabinet. Rembrandt's local colors are extremely good; he perfectly understood the principles of the chiaro-oscuro; and it is said that he generally painted in a chamber so contrived as to admit but one ray of light, and that from above. The lights in his pictures were painted with a body of color unusually thick, as if it were his intention rather to model than to paint; but he knew the nature and property of each particular tint so thoroughly that he preserved them in full freshness, beauty, and lustre.

His genuine works are rarely to be met with, and afford incredible prices. Many of them, however, are in the collections of our English nobility. The etchings of Rembrandt are exceedingly admired, and collected with great care and expense for the cabinets of the curious in most parts of Europe; but it is remarked that none of his prints are dated earlier than 1628, nor later than 1659, though there are several of his paintings dated in 1660, and particularly the portrait of a Franciscan Friar. There is, perhaps, no branch of collectorship that exhibits more caprice than that of prints in general, or those of Rembrandt in particular. Instances of this may be adduced in the Juno without the crown; the Coppenol with a white back ground; the Joseph with the face unshaded, and the good Samaritan, with the horse's tail white, which are regarded as inestimable; whilst the same subjects, without these distinctions, are considered as of little comparative value. Strutt says that, in consequence of a commission from an eminent collector, he bid forty-six guineas for the Coppenol, with the white back ground, that is, in its unfinished state; though at the same sale he bought a beautiful impression of that plate in a perfect condition, for fourteen guineas and a half. Rembrandt is supposed to have taken advantage of this humor in collectors, by altering and obliterating parts of his plates to render them objects of enquiry. He also suffered himself to be solicited before he would consent to part with his work; and it is a fact that the print of Christ healing the sick, usually denominated the 'hundred guilders,' was so called because he refused to sell it under that price. At present a good impression is worth from fifty to sixty guineas. The rarest and most expensive of Rembrandt's portraits are those of Uttenbogard, called the Gold Weigher, and, in France, the Banker; Van Tol, the advocate, and burgomaster Six, each of which is estimated at fifty guineas. This great artist died at Amsterdam

in 1674, or according to some accounts in 1688. His personal character was far from amiable; he was avaricious, and not very scrupulous in his means of getting money. He was also fond of low company, by which his taste and principles became degraded.

REMEDIOS, NUESTRA SENORA DE LOS, a reduced city of New Granada, and capital of the province of Rio-del Hacha, has a good parish church, and is defended by a castle of regular construction. It was taken and sacked by Francis Drake in 1596. Seventy-three miles east by north of Santa Martha, and 104 north west of Maracaibo. It was formerly famous for its pearl fisheries.

REM'EDY, *n. s. & v. a.* } *Fr. remede; Ital. REM'EDIABLE, adj.* } *Span. and Port. remedio; Lat. remedium. Antidote; agent*  
 REM'EDIATE, }  
 REM'EDILESS, } *or instrument of*  
 REM'EDILESSNESS, *n. s.* } *cure; medicine; that which counteracts any evil; taking of, for, or against, before the object; reparation: to cure or heal; repair or remove mischief: remediable is capable of renewing; remediate, medicinal: remediless, cureless; admitting no remedy: the noun substantive corresponding.*

In the death of a man there is no *remedy*.  
*Wisdom ii. 1.*

Sad Æsculapius

Imprisoned we in chains *remediless*. *Spenser.*

Sorry we are that any good and godly mind should be grieved with that which is done; but to *remedy* their grief lieth not so much in us as in themselves.  
*Hooker.*

All you, unpublished virtues of the earth,  
 Spring with my tears; be aidant and *remediate*  
 In the good man's distress. *Shakspeare. King Lear.*

Things, without all *remedy*,  
 Should be without regard. *Id. Macbeth.*

The war, grounded upon this general *remediless* necessity, may be termed the general, the *remediless*, or the necessary war. *Raleigh.*

What may be *remedy* or cure  
 To evils, which our own misdeeds have wrought  
*Milton.*

We, by rightful doom *remediless*,

Were lost in death, till he that dwelt above  
 High-throned in secret bliss, for us frail dust  
 Emptied his glory. *Id.*

Here hope began to dawn; resolved to try,  
 She fixed on this her utmost *remedy*. *Dryden.*

There is no surer *remedy* for superstitious and desponding weakness, than first to govern ourselves by the best improvement of that reason which providence has given us for a guide; and then, when we have done our own parts, to commit all cheerfully, for the rest, to the good pleasure of heaven, with trust and resignation. *L'Estrange.*

Civil government is the proper *remedy* for the inconveniences of the state of nature. *Locke.*

Flatter him it may, as those are good at flattering who are good for nothing else; but, in the mean time, the poor man is left under a *remediless* delusion.  
*South*

O how short my interval of woe!

Our griefs how swift, our *remedies* how slow. *Prior.*

The difference between poisons and *remedies* is easily known by their effects; and common reason soon distinguishes between virtue and vice. *Swift.*

REMEMBER, *v. a.* } Old Fr. *rememberer* ;  
 REMEMBERER, *n. s.* } Ital. *remembrare* ; Lat.  
 REMEMBRANCE, } *rememoror*. To keep  
 REMEMBRANCER. } or bear in mind ; pre-  
 serve from forgetfulness ; put in mind ; mention :  
 a rememberer is one who remembers : remem-  
 brance, memory ; retentiveness of memory ; re-  
 collection ; reminiscence ; memorial ; memento ;  
 note of something past or absent ; honorable  
 memory : remembrancer, one who reminds ; an  
 officer of his majesty's exchequer.

*Remember* not against us former iniquities.

*Psalm lxxix. 8.*

He having once seen and *remembered* me, even  
 from the beginning began to be in the rierward.

*Sidney.*

*Remember* thee !

Ay, thou poor ghost, while memory holds a place  
 In this distracted brain. *Remember* thee !

*Shakespeare.*

Joy, being altogether wanting,

It doth *remember* me the more of sorrow. *Id.*

Though Cloten then but young, time has not worn  
 him

From my *remembrance*. *Id. Cymbeline.*

A sly knave, the agent for his master,

And the *remembrancer* of her, to hold

The hand fast to her lord. *Id.*

Rosemary and rue keep

Seeming and savour all the winter long ;

Grace and *remembrance* be unto you both.

*Shakespeare.*

Keep this *remembrance* for thy Julia's sake. *Id.*

Let your *remembrance* still apply to Banquo ;

Present him eminence, both with eye and tongue. *Id.*

All are digested into books, and sent to the re-  
*membrancer* of the exchequer, that he may make pro-  
 cesses upon them. *Bacon.*

It grieves me to be *remembered* thus

By any one, of one so glorious. *Chapman.*

A brave master to servants, and a *rememberer* of  
 the least good office ; for his flock he transplanted  
 most of them into plentiful soils. *Wotton.*

If ever we have found any word or act of God cor-  
 dial to us, it is good to fetch it forth oft to the eye.  
 The renewing of our sense and *remembrance* makes  
 every gift of God perpetually beneficial.

*Bp. Hall's Contemplations.*

I would only *remember* them in love and preven-  
 tion, with the doctrine of the Jews, and the example  
 of the Grecians. *Holyday.*

God is present in the consciences of good and bad ;  
 he is there a *remembrancer* to call our actions to  
 mind, and a witness to bring them to judgment. *Taylor.*

Had memory been lost with innocence,  
 We had not known the sentence nor the offence ;  
 'Twas his chief punishment to keep in store  
 The sad *remembrance* what he was before. *Denham.*

These petitions, and the answer of the common  
 council of London, were ample materials for a con-  
 ference with the lords, who might be thereby *remem-  
 bered* of their duty. *Clarendon.*

He brings them back,

*Remembering* mercy and his covenant sworn. *Milton.*

I hate thy beams,

That bring to my *remembrance* from what state

I fell ; how glorious once above thy sphere. *Id.*

Thee I have heard relating what was done,

Ere my *remembrance*. *Id.*

Cry unto God ; for you shall be *remembered* of  
 him. *Barclay.*

Those proceedings and *remembrances* are in the  
 Tower, beginning with the twentieth year of Ed-  
 ward I. *Hals.*

Would I were in my grave ;  
 For, living here, you're but my cursed *remem-  
 brancers* :

I once was happy. *Otway's Venice Preserved.*

Sharp *remembrance* on the English part,

And shame of being matched by such a foe,

Rouse conscious virtue up in every heart. *Dryden.*

This is to be *remembered*, that it is not possible  
 now to keep a young gentleman from vice by a total  
 ignorance of it ; unless you will all his life mew him  
 up. *Locke.*

*Remembrance* is when the same idea recurs, with-  
 out the operation of the like object on the external  
 sensory. *Id.*

A citation ought to be certain, in respect of the  
 person cited ; for, if such certainty be therein omit-  
 ted, such citation is invalid, as in many cases here-  
 after to be *remembered*. *Ayliffe.*

This ever grateful in *remembrance* bear,

To me thou owest, to me the vital air. *Pope.*

We are said to *remember* any thing when the idea  
 of it arises in the mind with a consciousness that we  
 have had this idea before. *Watts.*

Sorrows *remembered* sweeten present joy. *Pollok.*

REMEMBRANCERS, anciently called clerks of  
 the remembrance, certain officers of the exche-  
 quer, whereof three are distinguished by the  
 names of the king's remembrancer, the lord trea-  
 surer's remembrancer, and the remembrancer of  
 the first fruits. The king's remembrancer enters  
 in his office all recognizances taken before the  
 barons for any of the king's debts, for ap-  
 pearances or observing of orders ; he also takes  
 all bonds for the king's debts, and makes out  
 processes thereon. He likewise issues processes  
 against the collectors of the customs, excise, and  
 others, for their accounts ; and informations upon  
 penal statutes are entered and sued in his office,  
 where all proceedings in matters upon English  
 bills in the exchequer chamber remain. He  
 makes out the bills of compositions upon penal  
 laws, takes the statement of debts, and into his  
 office are delivered all kinds of indentures and  
 other evidences which concern the assuring any  
 lands to the crown. He every year in crastino  
 animarum reads in open court the statute for  
 election of sheriffs ; and likewise openly reads in  
 court the oaths of all the officers, when they are  
 admitted. The lord treasurer's remembrancer  
 is charged to make out processes against all  
 sheriffs, escheators, receivers, and bailiffs, for  
 their accounts. He also makes out writs of fieri  
 facias, and extent for debts due to the king,  
 either in the pipe or with the auditors ; and pro-  
 cess for all such revenue as is due to the king on  
 account of his tenures. He takes the account or  
 sheriffs ; and also keeps a record, by which it  
 appears whether the sheriffs or other accountants  
 pay their proffers due at Easter and Michaelmas ;  
 and at the same time he makes a record, whereby  
 the sheriffs or other accountants keep their pre-  
 fixed days ; there are likewise brought into his  
 office all the accounts of customers, comptrollers,  
 and accountants, to make entry thereof on re-  
 cord ; also all estreats and amercements are cer-  
 tified here, &c. The remembrancer of the first  
 fruits takes all compositions and bonds for the

payment of first fruits and tenths; and makes out process against such as do not pay the same.

REMER'CIÉ, *v. a.* Fr. *remercier*. To thank. Obsolete.

Offering his service and his dearest life For her defence, against that earle to fight; She him *remercied*, as the patron of her life.

*Spenser.*

REMIGRATE, *v. n.* } Lat. *remigro*. To  
REMIGRA'TION, *n. s.* } remove back again: removal back again.

The Scots, transplanted hither, became acquainted with our customs, which, by occasional *remigrations*, became diffused in Scotland. *Hale.*

Some other ways he proposes to divest some bodies of their borrowed shapes, and make them *remigrate* to their first simplicity. *Boyle.*

REMIND', *v. a.* Re and mind. To put in mind; to force to remember.

When age itself, which will not be defied, shall begin to arrest, seize and *remind* us of our mortality by pains and dulness of senses; yet then the pleasure of the mind shall be in its full vigour. *South.*

The brazen figure of the consul, with the ring on his finger, *reminded* me of Juvenal's majoris pondera gemmæ. *Addison.*

REMINIS'CENCE, *n. s.* } Lat. *reminiscens*.  
REMINIS'CENTIAL, *adj.* } Recollection; recovery of ideas; relating to memory.

I cast about for all circumstances that may revive my memory or *reminiscence*.

*Hale's Origin of Mankind.*

Would truth dispense, we could be content with Plato, that knowledge were but remembrance, that intellectual acquisition were but *reminiscential* evocation. *Browne.*

For the other part of memory, called *reminiscence*, which is the retrieving of a thing at present forgot, or but confusedly remembered, by setting the mind to ransack every little cell of the brain; while it is thus busied, how accidentally does the thing sought for offer itself to the mind! *South.*

REMIREMONT, a town in the north-east of France, situated on the Moselle, among the Vosges mountains. It is the centre of the traffic of a large mountain district, and has some cotton manufactures and iron works. It had formerly a celebrated abbey for ladies of superior birth. The environs produce cherries and timber. Inhabitants 4000. Fourteen miles south-east of Epinal.

REMISS', *adj.* } Fr. *remis*; Lat. *remissus, remitto*. Slack;  
REMISS'IBLE, } negligent; not intense  
REMISS'ION, *n. s.* } or earnest; not strict:  
REMISS'LY, *adv.* } remissible is, admitting  
REMISS'NESS, *n. s.* } of forgiveness: remis-  
REMIT', *v. a. & v. n.* } sion is, relaxation;  
REMIT'TANCE, *n. s.* } abatement; the giving  
REMIT'TOR. } back or relapse of a disease; release; forgive-  
ness: the adverb and noun substantive follow  
the sense of remiss as negligent; lax: to remit  
is, to relax; resign; defer; forgive; send back;  
send money to a distance: as a verb neuter, to  
slacken; abate: remittance, the act of sending  
money to a distance; the sum of money sent: a  
remittor, he who sends it; and, in law, a restitu-  
tion to the possession of lands by a more an-  
cient title.

He that blasphemeth agens the Holy Gost, hath not *remission* into withoute ende, but he schal be gilti of everlastyng trespass. *Wiclif. Mark 3.*

Whose soever sins ye *remit*, they are *remitted* unto them; and whose soever sins ye retain, they are retained. *John xx. 23.*

How should it then be in our power to do it coldly or *remissly*? so that our desire being natural, is also in that degree of earnestness whereunto nothing can be added. *Hooker.*

Mad ire and wrathful fury makes me weep,  
That thus we die, while *remis* traitors sleep. *Shakspeare.*

My pittance is to call Lucetta back,  
And ask *remission* for my folly past. *Id.*

Or new, or by *remissness* new conceived,  
Are now to have no successive degrees. *Id.*

At my lovely Tamora's intreats,  
I do *remit* these young men's heinous faults. *Id.*  
Error misclaim, and forgetfulness do now and then  
become suitors for some *remission* of extreme rigour. *Bacon.*

The bishop had certain proud instructions in the front, though there were a pliant clause at the foot, that *remitted* all to the bishop's discretion. *Id.*

In grievous and inhuman crimes, offenders should be *remitted* to their prince to be punished in the place where they have offended. *Hayward.*

You said, if I returned next size in Lent,  
I should be in *remitter* of your grace;  
In the' interim my letters should take place  
Of affidavits. *Donne.*

Many believe the article of *remission* of sins, but they believe it without the condition of repentance, or the fruits of holy life. *Taylor.*

No great offenders 'scape their dooms;  
Small praise from lenity and *remissness* comes. *Denham.*

There was not an equal concurrence in the prosecution of this matter among the bishops; or some of them proceeding more *remissly* in it. *Clarendon.*

So willingly doth God *remit* his ire  
That plea *Milton.*

With God or man will gain thee no *remission*. *Id.*  
These nervous, bold, those languid and *remis*;  
Here cold salutes, but there a lover's kiss. *Roscommon.*

If when by God's grace we have conquered the first difficulties of religion, we grow careless and *remiss*, and neglect our guard, God's spirit will not always strive with us. *Tillotson.*

Your candour in pardoning my errors, may make me more *remis* in correcting them. *Dryden.*

With suppliant prayers their powers appease;  
The soft Napæan race will soon repent  
Their anger, and *remit* the punishment. *Id.*

The' Egyptian crown I to your hands *remit*;  
And, with it, take his heart who offers it. *Id.*

This bold return with seeming patience heard,  
The prisoner was *remitted* to the guard. *Id.*

This difference of intension and *remission* of the mind in thinking, every one has experimented in himself. *Locke.*

The magistrate can often, where the public good demands not the execution of the law, *remit* the punishment of criminal offences by his own authority, but yet cannot *remit* the satisfaction due to any private man. *Locke.*

As, by degrees, they *remitted* of their industry, loathed their business, and gave way to their pleasures, they let fall those generous principles, which had raised them to worthy thoughts. *South.*

Not only an expedition, but the *remission* of a

duty or tax, were transmitted to posterity after this manner. *Addison.*

A compact among private persons furnished out the several remittances. *Id. on Italy.*

I remit me to themselves, and challenge their natural ingenuity to say, whether they have not sometimes such shiverings within them?

*Government of the Tongue.*

n September and October these diseases do not abate or remit in proportion to the remission of the sun's heat. *Woodward.*

The great concern of God for our salvation is so far from an argument of remissness in us, that it ought to excite our utmost care. *Rogers's Sermons.*

Jack, through the remissness of constables, has always found means to escape. *Arbutnot.*

Another ground of the bishop's fears is the remission of the firstfruits and tenths. *Swift.*

When our passions remit, the vehemence of our speech remits too. *Broome's Notes on the Odyssey.*

**REMNANT, n. s. & adj.** Corrupted from **REMANENT**, which see. Residue; that which is left; or that remains; remaining.

Poor key-cold figure of a holy king!

Thou bloodless remnant of that royal blood,

Be't lawful that I invoke thy ghost? *Shakspeare.*

It seems that the remnant of the generation of men were in such a deluge saved. *Bacon.*

I was intreated to get them some respite and breathing by cessation, without which they saw no probability to preserve the remnant that had yet escaped. *King Charles.*

The remnant of my tale is of a length

To tire your patience. *Dryden's Knight's Tale.*

A feeble army and an empty senate,  
Remnants of mighty battles fought in vain.

*Addison.*

It bid her feel

No future pain for me; but instant wed

A lover more proportioned to her bed;

And quiet dedicate her remnant life

To the just duties of an humble wife. *Prior.*

See the poor remnants of these slighted hairs;  
My hands shall read what even thy rapine spares.

*Pope.*

The frequent use of the latter was a remnant of popery, which never admitted scripture in the vulgar tongue. *Swift.*

**REMO (St.)**, a sea-port of the Sardinian states, in the Genoa territory. It is built on an eminence rising gently from the Mediterranean. The gardens of orange and lemon trees with which it is surrounded render it a most delightful spot. The cathedral churches and college, are the only public edifices worth notice. The port is shallow, and admits only small vessels. In 1745, this place was bombarded by the British. Population 7500. Twenty-two miles east by north of Nice, and sixty-six south-east of Genoa.

**REMOLTEEN, part.** Re and molt. Melted again.

It were good to try in glass works, whether the crude materials, mingled with the glass already made and remolten, do not facilitate the making of glass with less heat. *Bacon.*

**REMONSTRATE, v. n.** } Fr. *remonstrer*;  
**REMONSTRANCE, n. s.** } Latin *remonstro*.

To represent strongly; show reason in strong terms; show; discovery (not in use); strong representation.

The same God which revealeth it to them, would also give them power of confirming it unto others, either

with miraculous operation, or with strong and invincible remonstrance of sound reason. *Hooker.*

You may marvel why I would not rather  
Make rash remonstrance of my hidden power,  
Than let him be so lost. *Shakspeare.*

A large family of daughters have drawn up a remonstrance, in which they set forth that, their father having refused to take in the Spectator, they offered to abate the article of bread and butter in the tea table. *Addison's Spectator.*

Importunate passions surround the man, and will not suffer him to attend to the remonstrances of justice. *Rogers.*

**REMORA, n. s.** Lat. *remora*. A let or obstacle: a fish or worm that sticks to ships, and retards their passage.

Of fishes you shall find in arms the whale, bearing, roach, and remora. *Peucham on Blazoning.*

The remora is about three-quarters of a yard long; his body before three inches and a half over; thence tapering to the tail end; his mouth two inches and a half over: his chops ending angularly; the nether a little broader, and produced forward near an inch; his lips rough with a great number of little prickles. *Grew.*

**REMORA**, the sucking fish, a species of **ECHENEIS**, which see.

**REMORSE, n. s.** } Fr. *remords*; Lat. *re-*  
**REMORSEFUL, adj.** } *morsus*. Pain of guilt;  
**REMORSELESS.** } reproach of conscience:  
hence tenderness; pity: the adjective corresponding.

Many little esteem of their own lives, yet for remorse of their wives and children, would be withheld. *Spenser.*

The rogues slighted me into the river, with as little remorse as they would have drowned a bitch's blind puppies. *Shakspeare.*

O Eglamour, think not I flatter,  
Valiant and wise, remorseful, well accomplished.

*Id.*

Eurylochus straight hasted the report  
Of this his fellows most remorseful fate. *Chapman.*  
Not that he believed they could be restrained from that impious act by any remorse of conscience, or that they had not wickedness enough to design and execute it. *Clarendon.*

Where were the nymphs, when the remorseless deep  
Closed o'er the head of your lov'd Lycidas? *Milton.*

Curse on the unpardoning prince, whom tears can draw

To no remorse; who rules by lion's law. *Dryden.*  
O the inexpressible horror that will seize upon a sinner, when he stands arraigned at the bar of divine justice! when he shall see his accuser, his judge, the witnesses, all his remorseless adversaries! *South's Sermons.*

**REMOTE, adj.** } Lat. *remotus*. Distant;  
**REMOTELY, adv.** } alien; abstracted; fo-  
**REMOTENESS, n. s.** } reign: the adverb and noun substantive corresponding.

Their rising all at once was as the sound  
Of thunder heard remote. *Milton.*  
An unadvised transiency from the effect to the remotest cause. *Glanville.*

It is commonly opinioned that the earth was thinly inhabited, at least not remotely planted before the flood. *Browne.*

The joys of heaven are like the stars, which by reason of our remoteness appear extremely little. *Boyle.*

Titian employed brown and earthly colours upon the forepart, and has reserved his greater light for *rem. teness* and the back part of his landscapes.

*Dryden.*

Two lines in Mezentius and Lausus are indeed *remotely* allied to Virgil's sense, but too like the tenderness of Ovid.

*Id.*

In this narrow scantling of capacity, it is not all *remote* and even apparent good that affects us.

*Locke.*

If the greatest part of bodies escape our notice by their *remoteness*, others are no less concealed by their minuteness.

*Id.*

How, while the fainting Dutch *remotely* fire, And the famed Eugene's iron troops retire, In the first front amidst a slaughtered pile, High on the mound he died.

*Smith.*

*Remote* from men, with God he passed his days; Prayer all his business; all his pleasure, praise.

*Parnel.*

His obscurities generally arise from the *remoteness* of the customs, persons, and things he alludes to.

*Addison.*

In quiet shades, content with rural sports, Give me a life *remote* from guilty courts.

*Granville.*

REMOVE', v. a., v. n., &	} Fr. <i>remuer</i> ; Lat. <i>removeo</i> . To put from its place; place at a distance: as a verb neuter, to change place; to go from place to place: as a noun substantive <i>remove</i> is synonymous with removal, and means change of place; state of being removed; departure; act of changing place or putting away; step in a scale of gradation; a small distance: <i>remotion</i> also is the act of removing, or state of being removed: removed, removedness, and remover, correspond with <i>remove</i> verb active: removable is such as may be removed.
REMOTION, n. s.	
REMOVABLE, adj.	
REMOVAL, n. s.	
REMOVED', adj.	
REMOVEDNESS, n. s.	

REMOVER.

place to place: as a noun substantive *remove* is synonymous with removal, and means change of place; state of being removed; departure; act of changing place or putting away; step in a scale of gradation; a small distance: *remotion* also is the act of removing, or state of being removed: removed, removedness, and remover, correspond with *remove* verb active: removable is such as may be removed.

He *removeth* away the speech of the trusty, and taketh away the understanding of the aged.

*Job xii. 20.*

The Irish bishops have their clergy in such subjection that they dare not complain of them; for knowing their own incapacity, and that they are therefore *removeable* at their bishop's will, they yield what pleaseth him.

*Spenser.*

By which *removal* of one extremity with another, the world, seeking to procure a remedy, hath purchased a mere exchange of the evil before felt.

*Hooker.*

All this safety were *remotion*, and thy defence absence.

*Shakespeare.*

Good God *remove*

The means that makes us strangers! *Id.*

Rosaline, this favour thou shalt wear; Hold, take you this, my sweet, and give me thine, So shall Biron take me for Rosaline:

And change your favours too; so shall your loves Woo contrary, deceived by these *removes*.

*Id.*

Your accent is something finer than you could purchase in so *removed* a dwelling.

*Id.*

I have eyes under my service, which look upon his *removedness*.

*Id.*

Let him, upon his *removes* from one place to another, procure recommendation to some person of quality residing in the place whither he *removeth*.

*Bacon's Essays.*

Hasty fortune maketh an enterpriser and *remover*, but the exercised fortune maketh the able man.

*Bacon.*

To heare, from out the high-haired oak of Jove, Counsaile from him, for means to his *remove* To his loved country.

*Chapman.*

He longer in this paradise to dwell Permits not; to *remove* thee I am come, And send thee from the garden forth to till The ground.

*Milton's Paradise Lost.*

This place should be both school and university, not needing a *remove* to any other house of scholarship.

*Milton.*

What is early received in any considerable strength of impress, grows into our tender natures; and therefore is of difficult *remove*.

*Glancville's Scepis.*

The consequent strictly taken, may be a fallacious illation, in reference to antecedency or consequence; as to conclude from the position of the antecedent unto the position of the consequent, or from the *remotion* of the consequent to the *remotion* of the antecedent.

*Browne's Vulgar Errors.*

So looked Astrea, her *remove* designed, On those distressed friends she left behind.

*Waller.*

A short exile must for show precede; The term expired, from Candia they *remove*, And happy each at home enjoys his love.

*Dryden.*

The sitting still of a paralytick, whilst he prefers it to a *removal*, is voluntary.

*Locke.*

They are farther *removed* from a title to be innate, and the doubt of their being native impressions on the mind, is stronger against these moral principles than the other.

*Id.*

In all the visible corporeal world, quite down from us, the descent is by easy steps, and a continued series of things, that in each *remove* differ very little one from the other.

*Id.*

If the *removal* of these persons from their posts has produced such popular commotions, the continuance of them might have produced something more fatal.

*Addison.*

A freeholder is but one *remove* from a legislator, and ought to stand up in the defence of those laws.

*Id.*

In such a chapel, such curate is *removeable* at the pleasure of the rector of the mother church.

*Ayliffe.*

How oft from pomp and state did I *remove*, To feed despair!

*Prior.*

The fiercest contentions of men are between creatures equal in nature, and capable, by the greatest distinction of circumstances, of but a very small *remove* one from another.

*Rogers.*

The *removal* of such a disease is not to be attempted by active remedies, no more than a thorn in the flesh is to be taken away by violence.

*Arbuthnot.*

You, who fill the blissful seats above!

Let kings no more with gentle mercy sway, But every monarch be the scourge of God, If from your thoughts Ulysses you *remove*, Who ruled his subjects with a father's love.

*Pope.*

Whether his *removal* was caused by his own fears or other men's artifices, supposing the throne to be vacant, the body of the people was left at liberty to chuse what form of government they pleased.

*Swift.*

His horse wanted two *removes*, your horse wanted nails.

*Id.*

REMOUNT, v. n. Fr. *remonter*. To mount again.

Stout Cymon soon *remounts*, and cleft in two His rival's head.

*Dryden.*

The rest *remounts* with the ascending vapours, or is washed down into rivers, and transmitted into the sea.

*Woodward.*

**REMPIAN**, an idol or Pagan god, whom St. Stephen says the Israelites worshipped in the wilderness as they passed from Egypt to the land of promise.—Acts vii. 43. That the martyr here quotes the words of the prophet Amos (ch. v. 26), all commentators are agreed. But, if this coincidence between the Christian preacher and the Jewish prophet be admitted, it follows that Chiun and Remphan are names of the same deity. Selden and other critics concluded that Chiun, and of course Remphan, is the planet Saturn; because Chiun is written Ciun, Cevan, Ceuan, Chevin; all of which are modern oriental names of that planet. But others, and particularly the late learned Dr. Doig, by various etymological arguments (which we need not quote), render it much more probable, that it was the *αστρακων* or *σείπιος* of the Greeks, the canis or stella canicularis of the Romans, and the dog-star of modern Europe. What confirms his interpretation is, that the idol consecrated by the Egyptians to Sothis, or the dog-star, was a female figure with a star on her head; and hence the prophet upbraids his countrymen with having borne the star of their deity.

**REMS AND FILS**, one of the twelve departments of the kingdom of Wurtemberg, to the east of that of the Rothenberg. Its area is 540 square miles; population 126,000. It is divided into the five bailiwicks of Gemund, Goppingen, Schorndorf, Lorch, and Geislingen. The chief town is Goppingen.

**REMUNERATE**, *v. a.* } Fr. *remunerer*;  
**REMUNERATION**, *n. s.* } Latin *remunero*. To  
**REMUNERATIVE**, *adj.* } reward; repay; re-  
 quite; recompense: the noun substantive and  
 adjective corresponding.

Is she not then beholden to the man,  
 That brought her for this high good turn so far?  
 Yes; and will nobly *remunerate*. *Shakespeare.*

Money the king thought not fit to demand, because he had received satisfaction in matters of so great importance; and because he could not *remunerate* them with any general pardon, being prevented therein by the coronation pardon. *Bacon.*

Bear this significant to the country maid Jaquenetta; there is *remuneration*; for the best ward of nine honour is rewarding my dependants.

*Shakespeare.*  
 He begets a security of himself, and a careless eye on the last *remunerations*.

*Browne's Vulgar Errors.*

The knowledge of particular actions seems requisite to the attainment of that great end of God, in the manifestation of his punitive and *remunerative* justice. *Boyle.*

A collation is a donation of some vacant benefice in the church, especially when such donation is freely bestowed without any prospect of an evil *remuneration*. *Ayliffe.*

**REMURIA**, festivals established at Rome by Romulus to appease the manes of his brother Remus. They were afterwards called *lemuria*, and celebrated yearly.

**REMURMUR**, *v. a.* Re and murmur. To utter back in murmurs; repeat in low hoarse sounds.

Her fellow nymphs the mountains tear  
 With loud laments, and break the yielding air;

The realms of Mars *remurmured* all around,  
 And echoes to the Athenian shores rebound.

*Dryden.*

His untimely fate, the Angitian woods  
 In sighs *remurmured* to the Fucine floods. *Id.*

Her fate is whispered by the gentle breeze,  
 And told in sighs to all the trembling trees;  
 The trembling trees, in every plain and wood.  
 Her fate *remurmur* to the silver flood. *Pope.*

**REMUS**, the twin brother of Romulus, was exposed together with his brother by the cruelty of his grandfather. In the contest which happened between the two brothers, about building a city, Romulus obtained the preference, and Remus, for ridiculing the rising walls, was put to death by his brother's orders, or by Romulus himself. See **ROMULUS**. The Romans were afflicted with a plague after this murder, upon which the oracle was consulted, and the manes of Remus appeased by the institution of *Remuria*.

**REMY** (Sr.) a town of France, in the department of the mouths of the Rhone, situated in a fertile plain, covered with meadows and gardens. It is chiefly remarkable for its circular promenade, and, about a mile from the town, there are a Roman triumphal arch and a mausoleum, both of remote antiquity, and in tolerable preservation. The environs produced formerly a vast quantity of olive oil. At present the chief article of trade is the wine supplied by the vines on the neighbouring hills. Marle is also found in the environs. Inhabitants 5100. Forty-two miles north-west of Marseilles.

**RENAIN**, or **ROXSE**, a large inland town of the Netherlands, in East Flanders. It has extensive woollen manufactures, and a considerable commercial intercourse; but the only public buildings of interest are a magnificent chateau, an hospital, and three churches. Inhabitants 10,000. Seven miles south of Oudenarde, and twenty-two south by west of Ghent.

**REN'ARD**, *n. s.* Fr. *renard*, a fox. The name of a fox in fable.

Before the break of day,  
*Renard* through the hedge had made his way.

*Dryden.*

**RENAUDOT** (Theophrastus), M. D., an eminent French physician, born in London in 1583. He settled in Paris, became first physician to the dauphin, and was the first who published a gazette in France. He also wrote the lives of the celebrated prince of Condé, of marshal Gassion, and of cardinal Mazarin. He died in Paris in 1653.

**RENAUDOT** (Eusebius), grandson of the doctor, was born in Paris in 1646. He was educated under the Jesuits, and at Harcourt College; and became famous for his skill in oriental history and languages. In 1700 he attended cardinal Noailles to Rome, where Clement V. made him prior of Fossay. He wrote many learned dissertations, published in the *Memoirs of the Academy of Inscriptions*, of which he was a member, as well as of the French Academy, and the Academy de la Crusca. He died in 1720.

**RENCOUNTER**, *n. s. & v. n.* Fr. *rencontre*. Clash; collision; to clash; encounter.

Virgil's friends thought fit to alter a line in Venus's speech that has a relation to the *rencounter*.

*Addison.*

You may as well expect two bowls should grow sensible by rubbing, as that the *rencounter* of any bodies should awaken them into perception.

*Collier.*

So when the trumpet sounding gives the sign,  
The jostling chiefs in rude *rencounter* join:  
So meet, and so renew the dextrous fight;  
Their clattering arms with the fierce shock resound.

*Granville.*

**RENCONTRE**, in single combats, is used by way of contradistinction to duel. When two persons quarrel and fight on the spot, without having premeditated the combat, it is called a *rencounter*.

**RENCONTRE**, in heraldry, an epithet applied to an animal whose face stands right forward as if coming to attack the person, as in the annexed figure:—



**REND**, *v. a. pret. and part. pass. rent.* Sax. *renban*; Goth. *renna*. To tear with violence; lacerate.

He *rent* a lion as he would have rent a kid, and he had nothing in his hand. *Judges xiv. 4.*

I will not *rent* away all the kingdom, but give one tribe to thy son. *1 Kings xi. 13.*

Will you hence

Before the tag return, whose rage doth *rend*  
Like interrupted waters, and o'erbear  
What they are used to bear? *Shakespeare.*

This council made a schism and *rent* from the most ancient and purest churches which lived before them. *White.*

By the thunderer's stroke it from the root is *rent*,  
So sure the blows which from high heaven are sent. *Cowley.*

What you command me to relate,  
Renews the sad remembrance of our fate,  
An empire from its old foundations *rent*. *Dryden.*

Thou viper

Hast cancelled kindred, made a *rent* in nature,  
And through her holy bowels gnawed thy way,  
Through thy own blood to empire. *Id.*

Look round to see

The lurking gold upon the fatal tree;  
Then *rend* it off. *Id. Æneis.*

Is it not as much reason to say, when any monarchy was shattered to pieces, and divided amongst revolted subjects, that God was careful to preserve monarchical power, by *rending* a settled empire into a multitude of little governments? *Locke.*

He who sees this vast *rent* in so high a rock, how the convex parts of one side exactly tally with the concave of the other, must be satisfied that it was the effect of an earthquake. *Addison.*

When its way the impetuous passion found,  
I *rend* my tresses, and my breast I wound. *Pope.*

**REN'DER**, *v. a. & n. s.* Fr. *rendre*; Span. *rendir*. To return; pay back; restore; give on demand; give generally; yield; surrender; exhibit a surrender.

Will ye *render* me a recompense? *Joel iii. 4.*

The sluggard is wiser in his own conceit than seven men that can *render* a reason. *Proverbs.*

I heard him speak of that same brother,  
And he did *render* him the most unnatural  
That lived 'mongst men. *Shakespeare.*

Newness

Of Cloten's death, we being not known, nor mustered  
Among the bands, may drive us to a *render*. *Id.*

My *rendering* my person to them, may engage their affections to me. *King Charles.*

Saint Augustine *renders* another reason, for which the apostles observed some legal rites and ceremonies for a time. *White.*

One, with whom he used to advise, proposed to him to *render* himself upon conditions to the earl of Essex. *Clarendon.*

Let him look into the future state of bliss or misery, and see there God, the righteous judge, ready to *render* every man according to his deeds. *Locke.*

*Render* it in the English a circle; but 'tis more truly *rendered* a sphere.

*Burnet's Theory of the Earth.*

Because the nature of man carries him out to action, it is no wonder if the same nature *renders* him solicitous about the issue. *South's Sermons.*

Hither the seas at stated times resort,  
And shove the loaden vessels into port;  
Then with a gentle ebb retire again,  
And *render* back their cargo to the main. *Addison.*  
Logick *renders* its daily service to wisdom and virtue. *Watts.*

Love

Can answer love, and *render* bliss secure.

*Thomson.*

Would he *render* up Hermione,  
And keep Astyanax, I should be blest! *A. Philips.*

Mr. Hook, in his *Philos. Exper.* p. 306, imagines this to be a dilatable or compressible tube, like the air bladders of fish, and that, by contracting or permitting it to expand, it *renders* its shell buoyant or the contrary. *Darwin.*

**RENDEZVOUS'**, *n. s. & v. n.* Fr. *rendezvous*. Assembly; meeting appointed; appointed sign of meeting; to meet at any appointed place.

A commander of many ships should rather keep his fleet together than have it severed far asunder; for the attendance of meeting them again at the next *rendezvous* would consume time and victual.

*Raleigh's Apology.*

The philosopher's-stone and a holy war are but the *rendezvous* of cracked brains, that wear their feather in their head instead of their hat. *Bacon.*

The king appointed his whole army to be drawn together to a *rendezvous* at Marlborough.

*Clarendon.*

This was the general *rendezvous* which they all got to, and, mingling more and more with that oily liquor, they sucked it all up. *Burnet.*

**RENEALMIA**, in botany, wild pine-apple, a genus of the monogymia order, and monandria class of plants: cor. trifid; nectarium oblong; CAL. monophyllous; anthera sessile, opposite to the nectarium; the berry fleshy. Species one only, a native of Surinam.

**RENEGADE'**, *n. s. & v. n.* Fr. *renegat*; Span. *RENEGA'DO*. } *renegado*. An apostate; a revolter.

Some straggling soldiers might prove *renegadoes*, but they would not revolt in troops.

*Decay of Piety.*

There lived a French *renegado* in the same place where the Castilian and his

If the Roman government would have had *renegade* so enough.

**RENEGE'**, *v. a.* Lat. Obsolete.



RENEW, *v. a.* } Re and new; Lat. *re-*  
 RENEWABLE, *adj.* } *novus*. To renovate; re-  
 RENEWAL, *n. s.* } store; repeat: the adject-  
 tive and noun substantive corresponding.

The body percussed hath, by reason of the percus-  
 sion, a trepidation wrought in the minute parts, and  
 so *reneweth* the percussion of the air. *Bacon.*

In such a night  
 Medea gathered the enchanted herbs,  
 That did *renew* old Æson. *Shakespeare.*

The last great age, foretold by sacred rhymes,  
*Renews* its finished course, Saturnian times  
 Roll round again. *Dryden's Virgil Pastorals.*

*Renewed* to life, that she might daily die,  
 I daily doomed to follow *Dryden.*

RENFREW [Gael. Rein Froach, i. e. the heath division], an ancient royal borough of Scotland, the capital of Renfrewshire, and the seat of the sheriff's court, and of a presbytery. It is seated on the Cathcart, which runs into the Clyde five miles above Glasgow. King Robert II. had a palace in it. The town consists of one narrow street, half a mile long, with some small lanes. It was made a royalty by king Robert, and has charters from king James VI. and queen Anne. It is governed by a provost, two bailies, and sixteen counsellors; who send a delegate to join with those from Glasgow, Dumbarton, and Rutherglen, in electing a representative in the imperial parliament. It has a salmon fishery on the Clyde, from Scotstown to Kelly bridge. Its chief manufactures are, a soap and candle work; a bleachfield, and about 200 looms are employed in muslins for Paisley. It formerly stood on the banks of the Clyde, and vessels of considerable burden were built close to the town; but the river, changing its course nearly opposite to Scotstown, took a semicircular direction, leaving King's Inch on the north, and came into its present course above the ferry. To supply this deficiency a large canal has been made along the old bed of the river, from the Clyde to the town, by which large vessels come up and unload at spring tides. It is three miles north of Paisley, six west of Glasgow, and forty-five east of Edinburgh.

RENFREW, or RENFREWSHIRE, a county of Scotland, about twenty-eight miles long from east to west, and from ten to twenty-four broad, bounded on the east by Lanarkshire, south by Ayrshire, west by the Clyde, which separates it from Dumbartonshire, and north by Cunningham. The surface is beautifully variegated with hills and valleys, woods and rivers, populous towns, villages, and gentlemen's seats. A considerable part of the soil is moorish and barren; but along the banks of the Clyde, the Gryfe, the White and Black Carts, it is fertile. The general scenery is romantic and delightful. It abounds with coals, iron-stone, and other minerals. Its chief towns are Paisley, Greenock, Port Glasgow, and Renfrew. It is divided into seventeen parishes. This county is sometimes called the barony, because it was anciently the inheritance of the royal house of Stuart; and still affords the title of baron to the prince of Wales.

RENI (Guido or Guy), an illustrious Italian painter, born at Bologna in 1595. He first studied under Denis Calvert, and afterwards under the Caracci. He imitated Lewis Caracci, but afterwards formed a peculiar style of his own, that secured him the admiration of his contemporaries and of posterity. He was much honored, and lived in splendor; but afterwards ruined himself by gaming. He died in 1642. There are several of his designs in print, etched by himself.

RENITENT, *adj.* Lat. *renitens*. Acting against any impulse elastically.

RENNEL, (John), was born in 1742, and, at thirteen, was sent on board a ship-of-war as a midshipman, and served in India. In 1766, he entered into the East India company's military service, and was afterwards appointed surveyor-general of Bengal. He soon after gave to the world his Bengal Atlas, and an Account of the Ganges and Burrampooter. He returned to England in 1782, and published a Map of India, accompanied by a memoir. Besides the works already mentioned, he was the author of Memoir on the Geography of Africa, with a map (1790); the Marches of the British Army in the Peninsula of India (1792); Elucidation of African Geography (1793); a second and third Memoir of the Geography of Africa (1799); the Geographical System of Herodotus explained (4to, 1800); Observations on the Topography of the Plain of Troy. He died in 1830.

RENNELL (Thomas), B.D., F.R.S., son of Dr. Rennell, dean of Winchester, master of the temple, &c., and grandson, by the mother's side, of Sir William Blackstone, was born at Winchester in 1787. At an early age he was placed at Eton, where he distinguished himself by his progress in classical literature, and obtained Dr. Buchanan's prize for the best Greek Sapphic ode on the Propagation of the Gospel in India. He joined at this period three of his contemporaries in the publication of a series of essays, under the name of the Miniature, which went through two editions. In 1806 he removed to King's College, Cambridge, and gave additional proof of his literary attainments, by gaining, in 1808, Sir William Browne's annual Greek medal for an ode entitled Veris Comites, as well as by his contributions to the Museum Criticum. Having taken orders, he became assistant preacher to his father at the Temple church, and in 1811 published his Animadversions on the Unitarian Translation of the New Testament, under the designation of A Student in Divinity, and about the same time became editor of the British Critic. In 1816 he was elected Christian advocate in the university of Cambridge, and the bishop of London conferred on him in the same year the vicarage of Kensington. In the former capacity he produced his Remarks on Scepticism as it is connected with the subjects of Organization and Life. Mr. Rennell was the rather induced to enter into this inquiry as he had himself made no slight progress in the study of anatomy. It was first printed in 1819, and went rapidly through six editions. His last work, undertaken in the same character, was entitled Proofs of Inspiration, or the Grounds of Distinction

between the New Testament and the Apocryphal Volume. In 1823 he obtained the mastership of St. Nicholas' hospital, with a stall in Salisbury cathedral; and in the same year a pamphlet appeared from his pen addressed to H. Brougham, esq., M. P., on the subject of a speech made by that gentleman at Durham, taken in connexion with some articles in the Edinburgh review. In the autumn of this year he married a Miss Delafield of Kensington; not many weeks after which a violent attack of fever terminated in a gradual decline, which carried him off in June the following year, just as he had completed his new translation of Munter's Narrative of the Conversion of Count Struensee. In private life he was highly esteemed.

RENNES, a large town of France, the former capital of Brittany, and now of the department of the Ille and Vilaine, is situated in a large plain, at the confluence of these two rivers. The latter divides the town into two parts, connected by bridges. That built on the left bank of the river, and called the Lower Town, is almost on a level with the surface of the water, and subject consequently to inundations. The Upper Town, on the right bank, stands on an eminence, and forms the most considerable part of the city. Since a dreadful fire in 1720, by which nearly 900 houses were consumed, Rennes has been rebuilt on a regular plan; but a few of the narrow streets and high antiquated houses remain; and in the suburbs there is a number of wooden structures. The square called the Palais de Justice was constructed on the model of the Place Vendome at Paris, and had once a bronze statue of Louis XIV. Of the Place d'armes the Hotel de Ville forms the western façade; this, as well as the Place de la grande Cohue, and the Place de la Pompe, are all worth notice. The principal promenades are the Cours and the Tabor; the former nearly a mile long.

The principal public edifices are the cathedral, dedicated to St. Peter; the building, formerly the house of meeting for the parliament of Brittany; the town-hall, arsenal, and a college formerly belonging to the Jesuits. Here is also a small university, famous for the study of law; also a society of arts and sciences. It has besides a college royal, an academy, a school of medicine and surgery, and a drawing school; a public library, museum, physical cabinet, chemical laboratory, botanical garden, &c. The trade is promoted by the Vilaine being navigable for large vessels towards its mouth, and for barges of considerable burden to this place. The objects of commerce are corn, cattle, hemp, flax, and timber; lead, wax, and butter. The manufactures consist of blankets, sail-cloth, hats, thread, stockings, gloves, and hardware. Rennes is the see of a bishop, and the seat of a court of appeal for four adjoining departments. It has likewise criminal and commercial courts. Inhabitants 30,000. Eighty miles north of Nantes, and 220 west of Paris.

REN'NET, *n. s.* } Properly Fr. *rainette*, a  
REN'NETING. } little queen. A kind of  
apple.

A golden *rennet* is a very pleasant and fair fruit,

of a yellow flush, and the best of bearers for all sorts of soil; of which there are two sorts, the large sort and the small.

Ripe pulpy apples, as pippins and *rennetings*, are of a syrupy tenacious nature.

REN'NET, *n. s.* See RUNET, and below.

A putredinous ferment coagulates all humours, as milk with *rennet* is turned.

*Floyer on the Humours.*

RENNET, in rural economy, a term applied to the coagulum prepared from the stomach of a young calf for the purpose of making cheese. See DAIRY.

RENNIE (John), F. R. S., the celebrated engineer, was born near Linton in East Lothian, in 1760, and was the son of a respectable farmer, who placed him with an eminent mill-wright. After serving out his articles, he commenced business on his own account, but in 1783 was induced to remove to London, where he distinguished himself by the construction of the Albion mill. His next work of magnitude was the erection of machinery in Whitbread's brewery. His reputation from this time increased, until he was regarded as standing at the head of the English civil engineers. Among his works may be mentioned Ramsgate harbour, Waterloo and Southwark bridges (as to construction), the Breakwater at Plymouth, and the Bell Rock light-house. No one has effected greater performances in the difficult branches of his profession. Although in some respects a self-taught man, he acquired the respect of the most distinguished men of science and learning in his day. His death took place at his house in Stamford Street, Blackfriars, October 4th, 1821, in his sixty-first year, and he was buried with the respect due to his eminent talents in St. Paul's cathedral.

REN'OVATE, *v. a.* } Lat. *renovo*. To renew;  
REN'OVATION, *n. s.* } restore to the first state:  
the noun substantive corresponding.

Sound continueth some small time, which is a *renovation*, and not a continuance; for the body percussed hath a trepidation wrought in the minute parts, and so reneweth the percussion of the air.

*Bacon's Natural History.*

To second life

Waked in the *renovation* of the just,

Resigns him up, with heaven and earth renewed.

*Milton.*

All nature feels the *renovating* force  
Of winter, only to the thoughtless eye  
In ruin seen.

*Thomson's Winter.*

RENOUNCE', *v. a. & v. n.* } Fr. *renoncer*;  
RENOUNCEMENT, *n. s.* } Lat. *renuncio*. To  
RENUNCIATION. } disown; abne-  
gate; abjure: Dryden's use of the word, as a verb  
neuter, has never been followed: the noun sub-  
stantive corresponding.

This world I do *renounce*; and in your sights  
Shake patiently my great affliction off. *Shakespeare.*

I hold you as a thing enskied and sainted;

By your *renouncement*, an immortal spirit. *Id.*  
Pride and passion, and the opinions of the world  
must not be our counsellors; for we *renounced* them  
at our baptism. *Kettlewell.*

From Thebes my birth I own; and no disgrace  
Can force me to *renounce* the honour of my race.

*Dryden*

On this firm principle I ever stood ;  
 He of my sons, who fails to make it good,  
 By one rebellious act renounces to my blood. *Id.*  
 He that loves riches, can hardly believe the doctrine of poverty and renunciation of the world.

*Taylor.*

RENOWN', *n. s. & v. a.* Fr. *renommée*; Lat. *renomem*. Fame; celebrity; praise widely spread; to make famous.

These were the *renowned* of the congregation,  
 princes of the tribes, heads of thousands. *Numbers.*  
*She*

Is daughter of this famous duke of Milan,  
 Of whom so often I have heard *renown*. *Shakespeare.*

Let us satisfy our eyes

With the memorials and the things of fame,  
 That do *renown* this city. *Id.*

That thrice *renowned* and learned French king,  
 finding Petrarch's tomb without any inscription,  
 wrote one himself; saying, Shame it was that he  
 who sung his mistress's praise seven years before her  
 death, should twelve years want an epitaph.

*Peacham.*

The rest were long to tell, though far *renowned*.

*Milton.*

'Tis of more *renown*

To make a river, than to build a town. *Waller.*  
 Nor envy we

Thy great *renown*, nor grudge thy victory. *Dryden.*

Soft elocution does thy style *renown*,  
 Gentle or sharp according to thy choice, *Id.*  
 To laugh at follies or to lash at vice.

*Ilva,*

An isle *renowned* for steel and unexhausted mines.

*Id.*

In solemn silence stand

Stern tyrants, whom their cruelties *renown*  
 And emperors in Parian marble frown. *Addison.*  
 A bard, whom piller'd pastorals *renown*. *Pope.*

Nor far beneath her in *renown* is she  
 Who, through good breeding, is ill company;  
 Whose manners would not let her larum cease,  
 Who thinks you are unhappy when at peace.

*Young.*

And when recording History displays

Feats of *renown*, though wrought in ancient days;  
 Tells of a few stout hearts, that fought and died,  
 Where duty placed them, at their country's side;  
 The man that is not moved with what he reads,  
 That takes not fire at their heroic deeds,  
 Unworthy of the blessings of the brave,  
 Is base in kind, and born to be a slave. *Cowper.*

RENSSLAER, a county of New York, United States, bounded north by Washington county, east by Vermont and Massachusetts, south by Colombia county, and west by the Hudson. The eastern part is hilly, and in some parts mountainous: indeed the general character of the country is broken and hilly; but the valleys are extensive, and the alluvial flats of considerable extent, warm and fertile. The wet uplands are covered with a luxuriant growth of lofty white pine, variously intermixed with hemlock, maple ash, cherry, beech, and birch; and the skilful farmer finds all the varieties of soil which these contrarities of forest vegetation would indicate. It sends four members to the house of assembly. The chief towns are Troy and Lansinburgh.

RENT, *v. n.* [now written rant, yet probably from rend]. To roar; to bluster: we still say, a tearing fellow.

He ventured to dismiss his fear,  
 That partings went to rent and tear,  
 And give the desperatest attack  
 To danger still behind his back. *Hudibras.*

RENT, *v. a. & n. s.* } Fr. *rente*; Ital. *rendita*;  
 RENTER. } low Lat. *reddendum*. Re-  
 venue; annual payment; to hold as a tenant.  
 See below: a renter is he who pays rent.

Idol ceremony,

What are thy *rents*? what are thy comings in?  
 O, ceremony, shew me but thy worth! *Shakespeare.*  
 Such is the mould, that the blest tenant feeds  
 On precious fruits, and pays his *rent* in weeds.

*Waller.*

The estate will not be let for one penny more or less to the *renter*, amongst whomsoever the *rent* be pays be divided. *Locke.*

When a servant is called before his master, it is often to know, whether he passed by such a ground, if the old man who *rents* it is in good health.

*Addison's Spectator.*

I bought an annual *rent* or two,  
 And live just as you see I do. *Pope.*

Folks in mudwall tenement,  
 Present a peppercorn for *rent*. *Prior.*

Anticipated *rents*, and bills unpaid,  
 Force many a shining youth into the shade,  
 Not to redeem his time, but his estate,  
 And play the fool, but at a cheaper rate. *Cowper.*

RENTS are classed by Blackstone among incorporeal hereditaments. The word *rent* or *render*, redditus, according to him, signifies a compensation or return, it being in the nature of an acknowledgment, given for the possession of some corporeal inheritance. See 1 Inst. 144. It is defined to be a certain profit issuing yearly out of lands and tenements corporeal. It must be a profit; yet there is no occasion for it to be, as it usually is, a sum of money: for spurs, capons, horses, corn, and other matters may be rendered, and frequently are rendered, by way of *rent*. It may also consist in services or manual operations; as, to plough so many acres of ground, to attend the king or the lord to the wars, and the like; which services, in the eye of the law, are profits. This profit must also be certain; or that which may be reduced to a certainty by either party. It must also issue yearly; though there is no occasion for it to issue every successive year; but it may be reserved every second, third, or fourth year: yet, as it is to be produced out of the profits of lands and tenements as a recompense for being permitted to hold or enjoy them, it ought to be reserved yearly, because those profits do annually arise, and are annually renewed. It must issue out of the thing granted, and not be part of the land or thing itself; wherein it differs from an exception in the grant, which is always of part of the thing granted. Plowd. 13: 8 Rep. 71. It must, lastly, issue out of lands and tenements corporeal; that is, from some inheritance whereunto the owner or grantee of the *rent* may have recourse to distrain. Therefore a *rent*, strictly speaking, cannot be reserved out of an advowson, a common, an office, a franchise, or the like; but a grant of such annuity or sum (e.g. by a lessee of tithes, or other incorporeal hereditament) may operate as a personal contract, and oblige the grantor to pay the money reserved, or subject him to an action of

debt for the amount of the rent agreed upon; though it doth not affect the inheritance, and is no legal rent in contemplation of law. And the king might always reserve a rent out of incorporeal hereditaments; the reason of which is, that he, by his prerogative, can distrain on all the lands of his lessee. 1 Inst. 47, a. in n.

1. *Of the different kinds of rent.*—There are, at common law, three kinds of rent: rent-service, rent-charge, and rent-seck.

*Rent-service* is so called, because it hath some corporeal service incident to it; as, at the least, fealty, or the feudal oath of fidelity. 1 Inst. 142. For, if a tenant holds his land by fealty, and 10s. rent; or by the service of ploughing the lord's land and 5s. rent; these pecuniary rents, being connected with personal services, are therefore called rent-service. And for these, in case they be behind, or arriere, at the day appointed, the lord may distrain of common right, without reserving any special power of distress; provided he hath in himself the reversion, or future estate of the lands and tenements, after the lease or particular estate of the lessee or grantee is expired. The services are of two sorts, either expressed in the lease or contract, or raised by implication of law. When the services are expressed in the contract, the quantum must be either certainly mentioned, or be such as, by reference to something else, may be reduced to a certainty; for, if the lessor's demands be uncertain, it is impossible to give him an adequate satisfaction or compensation for them, as the jury cannot determine what injury he has sustained. Co. Litt. 96, a: Stil. 397: 2 Ld. Raym. 1160.

A *rent-charge* is where the owner of the rent has no future interest, or reversion expectant, in the land; as where a man, by deed, maketh over to others his whole estate in fee simple, with a certain rent payable thereout; and adds to the deed a covenant or clause of distress, that if the rent be arriere, or behind, it shall be lawful to distrain for the same. In this case the land is liable to the distress, not of common right, but by virtue of the clause in the deed: and therefore it is called a rent-charge, because in this manner the land is charged with a distress for the payment of it. 1 Inst. 143. A clear rent-charge must be free from the land-tax. Doug. 602.

Where a man, seised of lands, grants by deed-poll, or indenture, a yearly rent to be issuing out of the same land, to another in fee, in tail, for life or years, with a clause of distress; this is a rent-charge, because the lands are charged with a distress by the express grant or provision of the parties, which otherwise it would not be. So, if a man make a feoffment in fee, reserving rent, and if the rent be behind, that it shall be lawful for him to distrain; this is a rent charge, the word 'reserving' amounting to a grant from the feoffee. Litt. § 217: Co. Litt. 170 a: Plowd. 134.

An annuity is a thing very distinct from a rent-charge, with which it is frequently confounded: a rent-charge being a burden imposed upon and issuing out of lands; whereas an annuity is a yearly sum chargeable only upon the person of the grantor. Therefore if a man by deed grant to another the sum of £20 per

annum, without expressing out of what lands it shall issue, no land at all shall be charged with it; but it is a mere personal annuity: which is of so little account in the law, that, if granted to an eleemosynary corporation, it is not within the statutes of mortmain; and yet a man may have a real estate in it, though his security is merely personal. 2 Comm. c. 3. See 1 Inst. 144.

*Rent-seck*, *redditus siccus*, or barren rent, is in effect nothing more than a rent reserved by deed, but without any clause of distress. A rent-seck is so called because it is unprofitable to the grantee; as, before seisin had, he can have no remedy for recovery of it; as where a man seised in fee grants a rent in fee for life or years, or where a man makes a feoffment in fee or for life, remainder in fee reserving rent, without any clause of distress, these are rent-seck; for which, by the policy of the ancient law, there was no remedy, as there was no tenure between the grantor and grantee, or feoffor and feoffee; consequently, no fealty could be due. Litt. § 215, 218: Cro. Car. 520: Kelw. 104: Cro. Eliz. 656.

Though a rent is an incorporeal hereditament it is susceptible of the same limitations as other hereditaments. Hence it may be granted or devised for life, or in tail, with remainders or limitations over. But there is this difference between an entail of lands, and an entail of rent; that the tenant in tail of lands, with the immediate reversion in fee in the donor, may, by a common recovery, bar the entail and reversion: See title *Recovery*. Whereas the grantee in tail of the rent *de novo*, without a subsequent limitation of it in fee, requires, by a common recovery only a base fee, determinable upon his decease, and failure of the issues in tail: but if there is a limitation of it in fee, after the limitation in tail, the recovery of the tenure in tail gives him the fee-simple. The reason of this difference is, that it would be unjust that the conveyance of a grantee of a rent should give a longer duration, or existence to the rent, than it had in its original creation. It is true that the barring of an estate-tail in land is equally contrary to the intention of the grantor. But a rent differs materially from land. The old principles of the feudal law looked upon every modification of landed property, which was considered to be against common right, with a very jealous eye. Now a rent-charge was supposed to be against common right; the grantee of the rent-charge being subject to no feudal services, and being a burden on the tenant who was to perform them. Upon this principle the law, in every instance, avoided giving, by implication, a continuation to the rent, beyond the period expressly fixed for its continuance. Thus, if a tenant in tail of land die without issue, his wife is entitled to dower for her life out of the land, notwithstanding the failure of the issue; but the widow of a tenant in tail of rent is not entitled to her dower against the donor. So if a rent is granted to a man and his heirs, generally, and he dies without an heir, the rent does not escheat, but sinks into the land. It is upon this principle that, when there is not a limitation over in fee, a tenant in tail of

rent acquires by his recovery no more than a base fee; as has been already stated: but if there is a limitation in fee; after the particular limitation in tail, the grantor has substantially limited the rent in fee; and, therefore, it is doing him no injustice, that the recovery should give the donee who suffers it an estate in fee simple. 1 Inst. 298, a. in n.

There are also other species of rents, which are reducible to these three. Rents of assize are the certain established rents of the freeholders and ancient copyholders of a manor, which cannot be departed from or varied. 2 Inst. 19. Those of the freeholders are frequently called chief rents, *redditus capitales*; and both sorts are indifferently denominated quit-rents, *quieti redditus*, because thereby the tenant goes quit and free of all other services. When these payments were reserved in silver or white money, they were anciently called white-rents, or blanch-farms, *redditus albi*; in contradistinction to rents reserved in work, grain, or baser money, which were called *redditus nigri*, or black mail. 2 Inst. 19. Rack-rent is only a rent of the full value of the tenement, or near it. A fee-farm rent is a rent-charge issuing out of an estate in fee; of at least one-fourth of the value of the lands, at the time of its reservation: for a grant of lands, reserving so considerable a rent, is indeed only letting lands to farm in fee simple, instead of the usual methods for life or years. 1 Inst. 143. It seems that the quantum of the rent is not essential to create a fee-farm. See 1 Inst. 145 b. n. 5: And also, whether a fee-farm must necessarily be a rent-charge; or may not also be a rent-seck; and Doug. 605. These are the general divisions of rent; but the difference between them (in respect to the remedy for recovering them) is now totally abolished; and all persons may have the like remedy by distress for rents-seck, rents of assize, and chief-rents (if paid for three years within twenty years preceding the act, or if created since), as in case of rents reserved upon lease. Stat. 4 Geo. II. c. 28 § 5.

*II. Modes of recovering rent.*—By stat. 8 Ann. cap. 14. No goods, upon any tenements leased, shall be taken by any execution, unless the party, at whose suit the execution is sued out, shall, before the removal of such goods, pay to the landlord of the premises, or his bailiff, all money due for rent for the premises; provided the arrears do not amount to more than one year's rent: and, in case the arrears shall exceed one year's rent, then the party, paying the said landlord, or his bailiff, one year's rent, may proceed to execute his judgment: and the sheriff is required to levy and pay to the plaintiff, as well the money paid for rent, as the execution money. § 1. The act contains a proviso to prevent prejudice to the crown, in recovering and seizing debts, fines, and forfeitures. § 8. See *Ogilvy, v. Wingate*, Parl. Cas.

It shall be lawful for any person having rent due on any lease for life, years, or at will, determined to distrain for such arrears after determination of the leases: provided, That such distress be made within six calendar months after the determination of such lease, and during the continuance of such landlord's title, and during

the possession of the tenant from whom such arrear became due. Stat. 8, Ann. c. 14, sec. 6, 7. The above clauses were made to remedy the defect of the common law, under which the power of distress ceased with the tenure. 1 Inst. 162, b in n.

By stat. 4 Geo. II., cap. 28, in case any tenant for life or years, or other person who shall come into possession of any lands, &c., under or by collusion of such tenant, wilfully hold over, after the determination of such term, and after demand made in writing for delivering possession, such person holding over shall pay double the yearly value of the lands, &c., so detained, sec. 1.

In all cases between landlord and tenant, on half a year's rent being in arrear, the landlord having a right by law to re-enter for non-payment, may without any formal demand or re-entry, serve a declaration in ejectment; and in case of judgment or non-suit for not confessing lease, entry, and ouster, it shall appear that half a year's rent was due before a declaration served, and no sufficient distress to be found; and that the lessor in ejectment had power to re-enter; the lessor in ejectment shall recover judgment. Sec. 2. Lessees, &c., filing a bill in equity, shall not have an injunction against proceedings at law, unless they shall, within forty days after answer filed, bring into court such money as the lessors in their answer shall swear to be in arrear, over and above all just allowances, and costs taxed, there to remain till the hearing of the cause, or to be paid to the lessors on good security, subject to the decree of the court; and in case such bill shall be duly filed, and execution executed, the lessors shall be accountable for only so much as they shall really make of the premises from the time of their re-entry; and, if the same shall happen to be less than the usual rent reserved, the lessees shall not be restored to the possession until they shall make up the deficiency to the lessors. Sec. 3. If the tenant, at any time before trial, tender or pay into court all arrears with costs, proceedings on ejectments shall cease. Sec. 4.

Previous to the above statute, the courts, both of law and equity, had exercised a discretionary power of staying the lessor from proceeding at law, in cases of forfeiture for non-payment of rent, by compelling him to take the money really due to him.

By stat. 11 Geo. II., c. 19, it shall be lawful for the landlord, where the agreement is not by deed, to recover a reasonable satisfaction for the tenements occupied by defendants, in an action on the case, for the use and occupation of what was held; and if, in evidence on the trial, any parol demise or agreement, not by deed, whereon a certain rent was reserved, shall appear, plaintiff may make use thereof as an evidence of the quantum of the damages. Sec. 14.

If any tenant holding tenements at a rack-rent, or where the rent reserved be full three-fourths of the yearly value of the premises, who shall be in arrear for one year's rent, desert the premises, and leave the same uncultivated or unoccupied, so as no sufficient distress can be had to countervail the arrears; it shall be lawful for two justices of the peace (having no interest in the premises) to go upon and view the same, and to affix, on the mos

notorious part, notice in writing, what day (at the distance of fourteen days at least) they will return to take a second view; and if, on such second view, the tenant, or some person on his behalf, shall not appear and pay the rent in arrear, or there shall not be sufficient distress on the premises, the justices may put the landlord in possession, and the lease to such tenants as to any demise therein contained only shall become void. Sec. 16. In case any tenant give notice of his intention to quit, and shall not accordingly deliver up the possession at the time in such notice contained, the tenant, his executors, or administrators, shall pay to the landlord double the rent which he should otherwise have paid. Sec. 18.

By stat. 11 Geo. II. c. 19, above quoted, landlords are empowered to follow goods fraudulently and clandestinely removed off the premises within thirty days: but this applies to the goods of the tenant only, and not to those of a stranger. See the statutes 56 Geo. III. c. 88, and 58 Geo. III. c. 39, to amend the law of Ireland respecting the recovery of tenements from absconding, overholding, or defaulting tenants, and for protection of the tenant from undue distress, by which many provisions of the English acts are extended to Ireland.

The general remedy for rent is by distress, under the restrictions and directions of the statutes: but there are also other remedies particularised by Blackstone, 3 Comm. c. 15, which it will be sufficient here to notice in a summary manner.

By action of debt, for the breach of the express contract. This is the most usual remedy, when recourse is had to any action at all for the recovery of pecuniary rents: to which species of render almost all free services are now reduced since the abolition of the military tenures: But for a freehold rent, reserved on a lease for life, &c., no action of debt lay, by the common law, during the continuance of the freehold, out of which it issued; for the law would not suffer a real injury to be remedied by an action that was merely personal. 1 Roll. Abr. 595. But by stat. 8 Ann. c. 14, sec. 4, an action of debt is given for rents on leases for life or lives, as upon a lease for years: and by stat. 5 Geo. III. c. 17, which enables ecclesiastical persons to lease tithes and other incorporeal inheritances, action of debt is given (by sec. 3) for recovery of rent on such leases; and perhaps the first of these statutes extends to leases of incorporeal hereditaments. See 1 Inst. 47, *a in n*.

The rent in a lease must be reserved to the lessor, or his heirs, &c., and not to a stranger. See 1 Inst. 213, *b*. The principle which gave rise to this rule is, that rent is considered as a contribution for the land, and is therefore payable to those who would otherwise have had the land. It is to be observed that remainder men in a settlement, being at first view neither feoffors, donors, lessors, nor the heirs of feoffors, donors, or lessors, there seems to have been, for some time after the statute of Uses, a doubt whether the rents of leases, made by virtue of powers contained in settlements, could be reserved to them. In Chudleigh's case, 1 Rep. 159, it is

positively said, that if a feoffment in fee be made to the use of one for life, remainder to another in tail with several remainders over, with a power to the tenant for life to make leases, reserving the rent to the reversionsers, and the tenant for life accordingly make leases; neither his heirs, nor any of the remainder-men, shall have the rent. But, in *Harcourt v. Pole*, 1 Anders. 273, it was adjudged that the remainder-men might distrain in these cases: and in *T. Jones* 35, the dictum in Chudleigh's case is denied to be law. The determination in *Harcourt v. Pole* will appear incontrovertibly right, if we consider that both the lessees and remainder-men derive their estate out of the reversion or original inheritance of the settler; and therefore the law, to use Coke's expression in *Whitlock's case*, 8 Rep. 71, will distribute the rent to every one to whom any limitation of the use is made. 1 Inst. 214, *a in n*; and see *Id.* 213, *b in n*.

III. *Respecting the demand of rent.*—With respect to the necessity of demanding rent, there is a material difference between a remedy by re-entry, and a remedy by distress, for non-payment of the rent; for, where the remedy is by way of re-entry for non-payment, there must be an actual demand made, previous to the entry, otherwise it is tortuous; because such condition of re-entry is in derogation of the grant, and the estate at law being once defeated, is not to be restored by any subsequent payment: and it is presumed that the tenant is there residing on the premises, in order to pay the rent for preservation of his estate, unless the contrary appears by the lessor's being there to demand it. Therefore, unless there be a demand made, and the tenant thereby, contrary to the presumption, appears not to be on the land ready to pay the rent, the law will not give the lessor the benefit of re-entry, to defeat the tenant's estate, without a wilful default in him; which cannot appear without a demand has been actually made on the land. So, if there had been a *nomine pænæ* given to the lessor for non-payment, the lessor must demand the rent before he can be entitled to the penalty.

Where the remedy for recovery of rent is by distress, there needs no demand previous to the distress; though the deed says that if the rent be behind, being lawfully demanded, that the lessor may distrain; but the lessor, notwithstanding such clause, may distrain when the rent becomes due. So it is, if a rent-charge be granted to A, and if it be behind, being lawfully demanded, that then A shall distrain; he may distrain without any previous demand.

But this general distinction must be understood with these restrictions:—That if the king makes a lease, reserving rent, with a clause of re-entry for non-payment, he is not obliged to make any demand previous to his re-entry; but the tenant is obliged to pay his rent for the preservation of his estate, because it is beneath the king to attend his subject to demand his rent.

But this exception is not to be extended to the duchy lands, though they be in the hands of the king; for the king must make a demand before he can re-enter into such lands, by the stat. 1 Hen. IV. c. 18, which provides, that, when the duchy lands come to the king, they shall not be

under such government and regulations as the demesnes and possessions belonging to the crown. Moor 149, 160. So, if a prebendary make a lease, rendering rent, and if the rent be in arrear and demanded, that it shall be lawful for the prebendary to re-enter; if the reversion in this case comes to the king, the king must in this case demand the rent, though he shall be by his prerogative excused of an implied demand: for the implied demand is the act of the law, the other the express agreement of the parties, which the king's prerogative shall not defeat. Therefore, in case of the king, if he makes a lease reserving rent, with a proviso, if the rent be in arrear for such a time (being lawfully demanded, or demanded in due form), that then the lease shall be void; it seems that not only the patentee of the reversion in this case, but also the king himself, whilst he continues the reversion in his own hands, is obliged to make an actual demand by reason of the express agreement for that purpose. Dyer 87, 210. But if the king, in cases where he need not make a demand, assigns over the reversion, the patentee cannot enter for non-payment, without a previous demand, because the privilege is inseparably annexed to the person of the king.

Another exception is, where the rent is payable at a place off the land, with a clause that if the rent be behind, being lawfully demanded at the place off the land, or where the clause is, if the rent be behind, being lawfully demanded of the person who is to pay it, that then he may distrain; in these cases, though the remedy be by distress only, yet the grantee cannot distrain without a previous demand: because here the distress and demand being not complicate, but different acts, to be performed at different places and times, the demand must be previous to the distress; for distress is an act of grace, not of common right, and therefore must be used in the manner that it is given.

And there seems to have been formerly another exception admitted, that where the remedy was by way of entry, for non-payment, yet there needed no demand, if the rent were made payable at any place off the land; because they looked on the money payable off the land to be in nature of a sum in gross, which the tenant had at his own peril undertaken to pay; but this opinion has been entirely exploded, for the place of payment does not change the nature of the service, but it remains in its nature a rent, as much as if it had been made payable on the land; therefore, the presumption is, that the tenant was there to pay it, unless it be overthrown by the proof of a demand; and without such demand, and a neglect or refusal, there is no injury to the lessor, consequently the estate of the lessee ought not to be defeated. But when the power of re-entry is given to the lessor for non-payment, without any further demand, there it seems that the lessee has undertaken to pay it, whether it be demanded or not; and there can be no presumption in his favor in this case; because by dispensing with the demand he has put himself under the necessity of making an actual proof that he was ready to tender and pay the rent. Dyer 68.

There is another exception, when the remedy is by distress, and that is, when the tenant was ready on the land to pay the rent at the day, and made a tender of it; there it seems there must be a demand previous to the distress; because, where the tenant has shown himself ready on the day by the tender, he has done all that in reason can be required of him; for it would put the tenant to endless trouble to oblige him every day to make a tender; it being altogether uncertain when the lessor will come for his rent, when he has omitted to receive it the day he appointed by the lease for payment and receipt; wherefore as the lessee must expect the lessor, and be ready to pay it at the day appointed, or else the lessor may distrain for it without any demand; so where the lessor has lapsed the day of payment, and was not on the land to receive it, he must give the tenant notice to pay it before he can distrain; for the tenant shall be put to no trouble where it appears that he has omitted nothing on his part. And where the tender was made by a tenant on the land at the day, there a demand on the land is sufficient to justify a distress after the day; because the demand in such case is of equal notoriety with the tender. But if the tenant had tendered the rent on the day to the person of the lessor, and he refused it, it seems, by the better opinion, that the lessor cannot distrain for that rent, without a demand of the person of the tenant; because the demand ought to be equally notorious to the tenant, as the tender was to the lessor. Hob. 207: 2 Roll. Abr. 427. So, if the services by which the tenant holds be personal, as homage, fealty, &c., the demand must be of the person of the tenant; because this service is only performable by the very person of the tenant, therefore a demand, where he is not, would be improper. Hut. 13: Hob. 207.

Again, if the rent be rent-seck, and the tenant be ready at the last instant of the day of payment to pay the rent, and the granter is not there to receive it, he must afterwards demand it of the person of the tenant on the lands, before he can have his assise; but in the case of a rent-charge, after such tender of the tenant on the land, the grantee may afterwards demand the rent on the land, because he has his remedy by distress, which is no more than a pledge for the rent; but in this case, if the grantee cannot find the tenant on the land to demand the rent, he may, on the next feast on which the rent is payable, demand all the arrears on the land; and, if the tenant is not there to pay it, he has failed of his duty, and is guilty of wilful default which amounts to a denial; and, that denial being a disseisin of the rent, the grantee may have his assise, and by that shall recover the arrears.

If a lease be made, reserving rent, and a bond given for performance of covenants and payment of the rent, the lessor may sue the bond without demanding the rent. If there be several things demised in one lease, with several reservations, with a clause, that, if the several yearly rents reserved be behind or unpaid in part, or in all, by the space of one month, after any of the days on which the same ought to be paid, that then it shall be lawful for the lessor, into such of the

premises, whereupon such rents, being behind, is or are reserved, to re-enter; these are in the nature of distinct demises, and several reservations; consequently there must be distinct demands on each demise to defeat the whole estate demised. Also, as to the necessity of a demand of the rent, there is a difference between a condition and a limitation; for instance, if tenant for life (as the case was by marriage settlement with power to make leases for twenty-one years, so long as the lessee, his executors, or assigns, shall duly pay the rent reserved) make a lease pursuant to the power; the tenant is at his peril obliged to pay the rent without any demand of the lessor; because the estate is limited to continue only so long as the rent is paid; therefore, for non-performance, according to the limitation the estate must determine; as if an estate be made to a woman dum sola fuerit, this is a word of limitation which determines her estate on marriage.

IV. *Of the time and place of demanding rent.*—Rent is regularly due and payable upon the land whence it issues, if no particular place is mentioned: but, in case of the king, the payment must be either to his officers at the exchequer, or to his receiver in the country. And, strictly, the rent is demandable and payable before the time of sun-set of the day whereon it is reserved; though perhaps not absolutely due till midnight. If the lessor dies before sun is set on the day upon which the rent is demandable, it is clearly settled that the rent unpaid is due to his heir, and not to his executor: but if he dies after sun-set, and before midnight, it seems to be the better opinion that it shall go to the executor, and not to the kin. 1 P. Wms. 178.

There is a material difference between the reservation of a rent payable on a particular day, or within a certain time after; and the reservation of a rent payable at a certain day, with a condition that, if it be behind, by the space of any given time, the lessor shall enter; in both cases a tender on the first or last day of payment, or on any of the intermediate days, to the lessor himself, either upon or out of the land, is good: but, in the former case it is sufficient, if the lessee attends on the first day of payment at the proper place; and, if the lessor does not attend there to receive the rent, the condition is saved. In the latter case, to save the lease it is not sufficient that the lessee attends on the first day of payment, for he must equally attend on the last day.

The other effects of this question of the time of the rent becoming due are now in equal measure superseded by the statute regulations already alluded to. But the following determinations on the subject may, notwithstanding, be requisite to be known. 1. The time for payment of rent, and consequently for a demand, is such a convenient time before the sun-setting of the last day as will be sufficient to have the money counted; but if the tenant meet the lessor on the land at any time of the last day of payment, and tenders the rent, that is sufficient tender, because the money is to be paid indefinitely on that day, therefore a tender on the day is sufficient. 2. If a lease is made, rendering rent at Michaelmas, between the hours of one and five

in the afternoon, with a clause of re-entry, and the lessor comes at the day, about two in the afternoon, and continues to five, this is sufficient. Cro. Eliz. 15.: The demand may be by attorney. 4 Leon. 479. But the power must be special, for such land and of such tenant: demand must be proved by witnesses, and must be made of the precise sum due. 3. If a lease be made, reserving rent on condition that if the rent be behind at the day, and ten days after (being in the mean time demanded), and no distress to be found upon the land, that the lessor may re-enter; if the rent be behind at the day, and ten days after, and a sufficient distress be on the land till the afternoon of the tenth day, and then the lessee takes away his cattle, and the lessor demands the rent at the last hour of the day, and the lessee does not pay it, and there is not any distress on the land; yet the lessor cannot enter, because he made no demand in the mean time between the day of payment, and the ten days, which by the clause he was obliged to do. 4. As to the place of demanding rent, there is a difference between a remedy by re-entry and distress; for when the rent is reserved, on condition that, if it be behind, that the lessor may re-enter, in such case the demand must be upon the most notorious place on the land; therefore, if there be a house on the land, the demand must be at the fore door thereof, because the tenant is presumed to be there residing, and the demand being required to give notice to the tenant that he may not be turned out of possession, without a wilful default, such demand ought to be in the place where the end and intention will be best answered. 5. And it seems the better opinion that it is not necessary to enter the house, though the doors be open, because that is a place appropriated for the peculiar use of the inhabitant, into which no person is permitted to enter without his permission; and it is reasonable that the lessor shall go no further to demand his rent than the tenant should be obliged to go, when he is bound to tender it; and a tender by the tenant at the door of the house of the lessor is sufficient, though it be open, without entering; therefore, by parity of reason, a demand by the lessor at the door of the tenant, without entering, is sufficient. But when the demand is only in order for a distress, there it is sufficient, if it be made on any notorious part of the land, because this is only to entitle him to his remedy for his rent; therefore, the whole land being equally debtor, and chargeable with the rent, a demand on it, without going to any particular part of it, is sufficient. Co. Litt. 153.

RENTING, in the manufactories, is the same with fine-drawing. It consists in sewing two pieces of cloth edge to edge, without doubling them, so that the seam scarcely appears; and hence it is denominated fine-drawing. It was originally a French word derived from the Latin *retrahere*, because the seam is drawn in or covered. In the East Indies, if a piece of fine muslin be torn, and afterwards mended by the fine-drawers, it will be impossible to discover where the rent was. In this country the dexterity of the fine drawers is not so great, but it is still such as to enable them to defraud the



revenue, by fastening a head or slip of English cloth on a piece of Dutch, Spanish, or other foreign cloth; or a slip of foreign cloth on a piece of English, so as to pass the whole as of a piece; and thus avoid the duties, penalties, &c. The trick was first discovered in France by M. Savary.

**RENTERING**, in tapestry, is the working new warp into a piece of tapestry damaged by rats or otherwise, and on this warp to restore the ancient pattern or design. The warp is to be of woollen, not linen. Among the titles of the French tapestry makers is included that of *renterers*.

**REORDAIN'**, *v. a.* } Fr. *reorderer*. Re  
**REORDINATION**, *n. s.* } and ordain. To ordain again: the noun-substantive corresponding. He proceeded in his ministry without expecting any new mission, and never thought himself obliged to a *reordination*. *Atterbury.*

**REPA'CIFIFY**, *v. n.* Re and pacify. To pacify again.

Henry, who next commands the state,  
 Seeks to *repacify* the people's heat. *Daniel.*

**REPAIR'**, *v. a., v. n., & n. s.* } Fr. *reparer* ;  
**REPAIR'ER**, *n. s.* } Latin *reparo* ;  
**REP'ARABLE**, *adj.* } Ital. *reparare* ;  
**REP'ARABLY**, *adv.* } To restore or  
**REPARA'TION**, *n. s.* } amend after in-  
**REPARA'TIVE**. } jury ; supply  
 loss ; revisit : as a noun-substantive, the supply or restoration made ; resort ; abode : reparation is the act of repairing : the other derivatives correspond.

Let the priests *repair* the breaches of the house.  
*2 Kings.*

Before the curing of a strong disease,  
 Ev'n in the instant of *repair* and health,  
 The fit is strongest. *Shakspeare. King Lear.*  
 May all to Athens back again *repair*. *Shakspeare.*  
 The parts in man's body easily *reparable*, as spirits,  
 blood, and flesh, die in the embracement of the parts  
 hardly *reparable*, as bones, nerves, and membranes.  
*Bacon.*

The king should be able, when he has cleared  
 himself, to make him *reparation*. *Id.*  
 He saw Ulysses ; at his ships *repair*,  
 That had been brusht with the enraged aire.  
*Chapman.*

New preparatives were in hand, and partly *repa-*  
*ratives* of the former beaten at sea. *Wotton.*

An adulterous person is tied to restitution of the  
 njury, so far as is *reparable*, and can be made to the  
 wronged person ; to make provision for the children  
 begotten in unlawful embraces. *Taylor.*

All automata need a frequent *repair* of new  
 strength, the causes whence their motion does pro-  
 ceed being subject to fail. *Wilkins.*

The fines imposed were the more repined against,  
 because they were assigned to the rebuilding and *repa-*  
*ir*ing of St. Paul's church. *Clarendon.*

The king sent a proclamation for their *repair* to  
 their houses, and for a preservation of the peace.  
*Id.*

Heaven soon *repaired* her mural breach. *Milton.*  
 To be revenged,

And to *repair* his numbers thus impaired. *Id.*  
 He cast in his mind for the *repair* of the cathedral  
 church. *Fell.*

When its spirit is drawn from wine, it will not by  
 the re-union of its constituent liquors be reduced to  
 its pristine nature ; because the workmanship of nature,  
 in the disposition of the parts was too elabo-

rate to be imitable, or *reparable* by the bare appo-  
 sition of those divided parts to each other. *Boyle.*

Suits are unlawfully entered, when they are vin-  
 dictive, not *reparative* ; and begun only for revenge,  
 not for *reparation* of damages. *Kettlewell.*

Temperance, in all methods of curing the gout, is  
 a regular and simple diet, proportioning the daily  
*repairs* to the daily decays of our wasting bodies.  
*Temple's Miscellanies.*

Depart from hence in peace,  
 Search the wide world, and where you please *repair*.  
*Druden.*

So 'scapes the insulting fire his narrow jail,  
 And makes small outlets into open air ;  
 There the fierce winds his tender force assail,  
 And beat him downward to his first *repair*. *Id.*  
 O sacred rest !

O peace of mind ! *repairer* of decay,  
 Whose balms renew the limbs to labours of the day.  
*Id.*

He that governs well, leads the blind, but he that  
 teaches, gives him eyes ; and it is a glorious thing to  
 have been the *repairer* of a decayed intellect.  
*South's Sermons.*

When the organs of sense want their due repose  
 and necessary *reparations*, the soul exerts herself in  
 her several faculties. *Addison.*

Antoninus Philosophus took care of the *reparation*  
 of the highways. *Arbutnot on Coins.*  
 'Tis fix'd ; the irrevocable doom of Jove :  
 Haste then, Cyllenius, through the liquid air,  
 Go mount the winds, and to the shades *repair*. *Pope.*

**REPAN'DOUS**, *adj.* Lat. *repandus*. Bent  
 upwards.

Though they be drawn *repandous* or convexedly  
 crooked in one piece, yet the dolphin that carrieth  
 Arion is concavously inverted, and hath its spine  
 depressed in another. *Browne.*

**REPARTEE'**, *n. s. & v. a.* French *repartie*.  
 Smart reply or saying : to make smart replies.

The fools overflowed with smart *repartees*, and  
 were only distinguished from the intended wits by  
 being called coxcombs. *Dryden.*

Cupid was as bad as he ;  
 Hear but the youngster's *repartee*. *Prior.*  
 High fights she had, and wit at will,  
 And so her tongue lay seldom still :  
 For in all visits, who but she,  
 To argue, or to *repartee*? *Id.*

**REPASS'**, *v. a. & v. n.* Fr. *repasser*. To pass  
 again ; pass or travel back : go back.

Well we have passed, and now *repassed* the seas,  
 And brought desired help. *Shakspeare. Henry VI.*

We shall find small reason to think that Abraham  
 passed and *repassed* those ways more often than he  
 was enforced so to do, if we consider that he had no  
 other comforter in this wearisome journey than the  
 strength of his faith in God. *Raleigh.*

Five girdles bind the skies, the torrid zone  
 Glows with the passing and *repassing* sun. *Dryden.*  
 If his soul hath winged the destined flight,  
 Homeward with pious speed *repass* the main,  
 To the pale shade funereal rites ordain. *Pope.*

**REPAST**, *n. s. & v. n.* } Fr. *repas* ; Lat. *re*  
**REPASTURE**. } and *pastus*. A meal ;  
 act of taking food ; food taken ; entertainment.

Go, and get me some *repast* ;  
 I care not what, so it be wholesome food.  
*Shakspeare.*

To his good friends I'll ope my arm,  
 And, like the kind life-rendering pelican,  
*Repast* them with my blood. *Id.*

He from forage will incline to play ;  
But if thou strive, poor soul, what art thou then ?  
Food for his rage, *repasture* for his den. *Id.*

Sleep, that is thy best *repast*,  
Yet of death it bears a taste  
And both are the same thing at last. } *Denham.*  
From dance to sweet *repast* they turn  
Desirous ; all in circles as they stood,  
Tables are set. *Milton's Paradise Lost.*  
What neat *repast* shall feast us, light and choice,  
Of Attick taste, with wine. *Milton.*

The day  
Had summoned him to due *repast* at noon. *Dryden.*  
Keep regular hours for *repast* and sleep. *Arbuthnot.*

REPAY', v. a. } Fr. *repayer*. Re and pay.  
REPAY'MENT, n. s. } To pay back ; requite ; re-  
venge: the act of paying back in any way.

According to their deeds he will *repay* recompense  
to his enemies ; to the islands he will *repay* recom-  
pense. *Isaiah lix. 18.*  
The poorest service is *repaid* with thanks. *Shakspeare.*

If you *repay* me not on such a day,  
Such sums as are expressed in the condition,  
Let the forfeit be an equal pound of your fair flesh. *Id.*

The false honour, which he had so long enjoyed,  
was plentifully *repaid* in contempt. *Bacon.*  
He clad

Their nakedness with skins of beasts, or slain ;  
Or as the snake with youthful coat *repaid*. *Milton.*  
I have fought well for Persia, and *repaid*

The benefit of birth with honest service. *Rowe.*  
The centesima usura it was not lawful to exceed ;  
and, what was paid over it, was reckoned as a *repay-  
ment* of part of the principal. *Arbuthnot.*

Fav'ring heav'n *repaid* my glorious toils  
With a sacked palace and barbarick spoils. *Pope.*

REPEAL', v. a. & n. s. Fr. *rappeller* ; Lat.  
*re* and *appello*. To recall (out of use) ; abro-  
gate : a revocation.

Laws that have been approved, may be again *re-  
pealed*, and disputed against by the authors them-  
selves. *Hooker's Preface.*

I will *repeal* thee, or be well assured,  
Adventure to be banished myself. *Shakspeare.*

If the time thrust forth  
A cause for thy *repeal*, we shall not send  
O'er the vast world to seek a single man. *Id.*

The king, being advertised that the over-large  
grants of lands and liberties made the lords so insol-  
ent, did absolutely resume all such grants ; but the  
earl of Desmond above all found himself grieved  
with this resumption or *repeal* of liberties, and de-  
clared his dislike. *Davies on Ireland.*

Adam soon *repealed*

The doubts that in his heart arose. *Milton.*  
Statutes are silently *repealed* when the reason  
ceases for which they were enacted. *Dryden.*

If the presbyterians should obtain their ends, I  
could not be sorry to find them mistaken in the  
point which they have most at heart, by the *repeal*  
of the test ; I mean the benefit of employments. *Swift*

REPEAT', v. a. } Lat. *repeto*, *repetere*.  
REPEATEDLY, adv. } To iterate ; use again ; do  
REPEATER, n. s. } or try again ; recite : re-  
REPEITION. } peatedly is, over and  
over ; more and more ; more than once : repeater,  
a particular kind of watch, see WATCH-MAKING :  
in a general sense corresponding, as well as re-  
petition, with the verb.

The psalms, for the excellency of their use, de-  
serve to be oftener *repeated* ; but that their multitude  
permitteth not any oftener *repetition*. *Hooker.*

These evils thou *repeatest* upon thyself,  
Have banished me from Scotland. *Shakspeare.*  
If you conquer Rome, the benefit,  
Which you shall thereby reap, is such a name,  
Whose *repetition* will be dogged with curses. *Id.*

He, though his power  
Creation could *repeate*, yet would be loth  
Us to abolish. *Milton.*  
He *repeated* some lines of Virgil, suitable to the  
occasion. *Waller's Life.*

Neglecting for Creusa's life his own,  
*Repeats* the danger of the burning town. *Waller.*  
Beyond this place you can have no retreat ;  
Stay here, and I the danger will *repeat*. *Dryden.*

Where sudden alterations are not necessary, the  
same effect may be obtained by the *repeated* force of  
diet with more safety to the body. *Arbuthnot.*

The frequent *repetition* of aliment is necessary for  
repairing the fluids and solids. *Id.*  
And are not these vices, which lead into damna-  
tion, *repeatedly*, and most forcibly cautioned against ?  
*Stephens.*

REPEL', v. a. & v. n. } Lat. *repello*. To  
REPEL'LENT, n. s. } drive back any thing  
or person ; resist force by force : that which has  
repelling power.

Neither doth Tertullian bewray this weakness in  
striking only, but also in *repelling* their strokes with  
whom he contendeth. *Hooker.*

Stand fast ; and all temptation to transgress *repel*.  
*Milton.*

Your foes are such as they, not you, have made,  
And virtue may *repel*, though not invade. *Dryden.*  
From the same *repelling* power it seems to be, that  
flies walk upon the water without wetting their feet.  
*Newton.*

In the cure of an erysipelas, whilst the body  
abounds with bilious humours, there is no admitting  
of *repellents*, and by discutients you will encrease the  
heat. *Wiseman.*

With hills of slain on every side,  
Hippomedon *repelled* the hostile tide. *Pope.*

REPENT', v. n. & v. a. } Fr. *repentir* ; Ital.  
REPENT'ANCE, n. s. } *pentir*, of Lat. *peni-  
REPENT'ANT, adj. } teo*. To think on any  
thing past with sorrow ; regret ; bemoan sin ;  
change the mind from fear or conviction of  
error ; change the mind generally ; to remember  
with sorrow : the adjective and noun substantive  
corresponding.

God led them not through the land of the Philis-  
tines, lest peradventure the people *repent* when they  
see war, and they return. *Ezodus xiii. 17.*

Judas, when he saw that he was condemned, *re-  
pent*ed himself. *Matthew xxvii. 3.*

Nineveh *repented* at the preaching of Jonas.  
*Id. xii. 41.*

In regard of secret and hidden faults, unless God  
should accept of a general *repentance* for unknown  
sins, few or none at all could be saved. *Perkins.*

*Repentance* so altereth a man through the mercy  
of God, be he never so defiled, that it maketh him  
pure. *Whitgifts.*

Poor Enobarbus did before thy face *repent*.  
*Shakspeare.*

I *repent* me that the duke is slain.  
Who by *repentance* is not satisfied,  
Is not of heaven nor earth ; for these are pleased ;  
By penitence the' Eternal's wrath's appeased. *Id.*

After I have interred this noble king,  
And wet his grave with my repentant tears,  
I will with all expedient dirty see you. *Id.*

*Repentance* is a change of mind, or a conversion from sin to God: not some one bare act of change, but a lasting durable state of new life, which is called regeneration. *Hammond.*

Thou, like a contrite penitent  
Charitably warned of thy sins, dost *repent*  
These vanities and giddinnesses: lo  
I shut my chamber-door; come, let us go. *Donne.*  
Nor had I any reservations in my own soul, when  
I passed that bill; nor *repentings* after. *King Charles.*

I will clear their senses dark  
What may suffice, and soften stony hearts  
To pray, *repent*, and bring obedience due. *Milton.*  
Thus they, in lowliest plight, *repentant* stood. *Id.*  
His late follies he would late *repent*. *Dryden.*

My father has *repented* him ere now,  
Or will *repent* him, when he finds me dead. *Id.*  
Upon any deviation from virtue, every rational creature so deviating, should condemn, renounce, and be sorry for every such deviation; that is, *repent* of it. *South.*

This is a confidence, of all the most irrational; for upon what ground can a man promise himself a future *repentance*, who cannot promise himself a futurity? *Id.*

Each age sinned on;  
Till God arose, and great in anger said,  
Lo! it *repenteth* me that man was made. *Prior.*  
Relentless walls! whose darksome round contains  
*Repentant* sighs and voluntary pains. *Pope.*  
Still you may prove the terror of your foes;  
Teach traitors to *repent* of faithless leagues. *A. Philips.*

The first step towards a woman's humility, seems to require a *repentance* of her education. *Law.*

**REPEOPLE, v. a.** Re and people; Fr. *re-peupler*. To stock anew with people.

An occurrence of such remark, as the universal flood and the *repeopling* of the world, must be fresh in memory for about eight hundred years; especially considering that the peopling of the world was gradual. *Hale's Origin of Mankind.*

**REPERCUSS', v. a.** } Lat. *repercutio*, re-  
**REPERCUS'SION, n. s.** } *percussus*. To beat  
**REPERCUS'SIVE, adj.** } back; drive back: act of driving back; rebound; the adjective corresponding.

Air in ovens, though it doth boil and dilate itself, and is *repercussed*, yet it is without noise. *Bacon.*

In echoes there is no new elision, but a *repercussion*. *Id.*

And *repercussive* rocks renewed the sound. *Pattison.*

By *repercussion* beams ingender fire,  
Shapes by reflection shapes beget;  
The voice itself when stopped does back retire,  
And a new voice is made by it. *Cowley.*

They various ways recoil, and swiftly flow  
By mutual *repercussions* to and fro. *Blackmore.*  
Amid Carnarvon's mountains rages loud  
The *repercussive* roar, with mighty crush  
Tumble the smitten cliffs. *Thomson.*

**REPINE, v. n.** Re and pine. To fret; vex oneself; be discontented: taking at and against. *Of late,*

When corn was given them gratis, you *repined*. *Shakspeare.*

The fines imposed were the more *repined* against because they were assigned to the rebuilding of St. Paul's church. *Clarendon.*

If you think how many diseases, and how much poverty there is in the world, you will fall down upon your knees, and, instead of *repining* at one affliction, will admire so many blessings received at the hand of God. *Temple.*

The ghosts *repine* at violated night,  
And curse the' invading sun, and sicken at the sight. *Dryden.*

**REPLACE, v. a.** Fr. *replacer*, re and place. To put again in a former place; place anew.

The earl being apprehended, upon examination cleared himself so well, as he was *replaced* in his government. *Bacon.*

The bowls, removed for fear,  
The youths *replaced*; and soon restored the cheer. *Dryden.*

**REPLANT, v. a.** Fr. *replanter*; re and plant. To plant anew.

Small trees being yet unripe, covered in autumn with dung until the spring, take up and *replant* in good ground. *Bacon.*

**REPLAIT, v. a.** Re and plait. To fold one part often over another.

In Raphael's first works, are many small foldings often *replaited*, which look like so many whipcords. *Dryden.*

**REPLENISH, v. a. & v. n.** Old Fr. *repleni*; Lat. *repleo*, from *re* and *plenus*. To stock; fill; consummate; recover fulness.

Multiply and *replenish* the earth. *Genesis i. 28.*  
We smothered

The most *replenished* sweet work of nature,  
That from the prime creation e'er she framed. *Shakspeare.*

The humours in men's bodies encrease and decrease as the moon doth; and therefore purge some day after the full; for then the humours will not *replenish* so soon. *Bacon.*

The woods *replenished* with deer, and the plains with fowl. *Heylin.*

The waters  
With fish *replenished*, and the air with fowl. *Milton.*

**REPLETE, adj.** } Fr. *replete*; Lat. *repletus*.  
**REPLETION, n. s.** } Full; filled completely, or to exuberance: the noun substantive corresponding.

The world's large tongue  
Proclaims you for a man *replete* with mocks;  
Full of comparisons and wounding flouts. *Shakspeare.*

The tree had too much *repletion*, and was oppressed with its own sap; for *repletion* is an enemy to generation. *Bacon.*

His words, *replete* with guile,  
Into her heart too easy entrance won. *Milton.*  
All dreams

Are from *repletion* and complexion bred;  
From rising fumes of undigested food. *Druden.*  
In a dog, out of whose eye, being wounded, the aqueous humour did copiously flow, yet in six hours the bulb of the eye was again *replete* with its humour, without the application of any medicines. *Ray.*

The action of the stomach is totally stopped by too great *repletion*. *Arbuthnot on Aliments.*

How each would trembling wait the mournful sheet,  
On which the press might stamp him next to die,  
And, reading here his sentence, how *replete*  
With anxious meaning, Heavenward turn his eye.

**REPLEVIN, v. a. }** Low Lat. *replegio*, of **REPLEVY.** } *re* and *plevir*, or Fr. *plegir*, to give a pledge. To take back or set at liberty, upon security, any thing seized.—A legal term.

That you're a beast, and turned to grass,  
Is no strange news, nor ever was;  
At least to me, who once, you know,  
Did from the pound *replevin* you. *Hudibras.*

**REPLEVIN**, in law, a remedy granted on a distress, by which the first possessor has his goods restored to him again on his giving security to the sheriff that he will pursue his action against the party distraining, and return the goods or cattle if the taking them shall be adjudged lawful. In a *replevin* the person distrained becomes plaintiff; and the person distraining is called the defendant or avowant, and his justification an avowry. At the common law *replevins* are by writ, either out of the king's bench or common pleas; but by statute they are by plaint in the sheriff's court, and court baron, for a person's more speedily obtaining the goods distrained. If a plaint in *replevin* be removed into the court of king's bench, &c., and the plaintiff make default and become nonsuit, or judgment is given against him, the defendant in *replevin* shall have the writ of *retorno habendo* of the goods taken in distress.

**REPLEVY**, in law, is a tenant's bringing a writ of *replevin*, or *replegiari facias*, where his goods are taken by distress for rent; which must be done within five days after the distress, otherwise at the five days' end they are to be appraised and sold.

**REPLICATION, n. s.** Lat. *replico*. Rebound; repercussion. Not in use. Reply.

Tyber trembled underneath his banks  
To hear the *replication* of your sounds  
Made in his concave shores. *Shakspeare.*

To be demanded of a sponge, what *replication* should be made by the son of a king? *Id.*

This is a *replication* to what Menelaus had before offered, concerning the transplantation of Ulysses to Sparta. *Broome.*

**REPLY, v. n., v. a. & n. s. }** Fr. *repliquer*. **REPLIER, n. s.** } To answer; make a return to an answer; return for answer; the return made: replier, he who answers.

O man! who art thou that *repliest* against God?  
*Romans ix.*

If I sent him word it was not well cut, he would send me word he cut it to please himself; if again, it was not well cut, this is called the *reply* churlish. *Shakspeare.*

At an act of the commencement, the answerer gave for his question, that an aristocracy was better than a monarchy: the *replyer* did tax him, that, being a private bred man, he would give a question of state. *Bacon's Apophthegms.*

Perplexed  
The tempter stood, nor had what to *reply*. *Milton.*  
His trembling tongue invoked his bride;  
With his last voice Eurydice he cried:  
Eurydice the rocks and river-banks *replied*. *Druden.*

Would we ascend higher to the rest of these lewd persons, we should find what reason Castalio's painter had to *reply* upon the cardinal, who blamed him for putting a little too much colour into St.

Peter and Paul's faces: that it was true in their lifetime they were pale mortined men, but that since they were grown ruddy, by blushing at the sins of their successors. *Atterbury's Sermons.*

To whom, with sighs, Ulysses gave *reply*;  
Ah, why ill-suited pastime must I try? *Pope.*  
One rises up to make *replies* to establish or confute what has been offered on each side of the question. *Watts.*

**REPOLISH, v. a.** Fr. *repolir*; re and polish. To polish again.

A sundred clock is piecemeal laid  
Not to be lost, but by the maker's hand  
*Repolished*, without error then to stand. *Donne.*

**REPORT, v. a. & n. s. }** Fr. *rapporter*. To give **REPORTER, n. s.** } back; noise by popu-  
**REPORTINGLY, adv.** } larumor; give report; the report or account given; sound; repercussion: a reporter is a relater; one who gives an account: the adverb corresponding with the verb.

*Report*, say they, and we will *report* it. *Jeremiah.*  
There is a king in Judah; and now shall it be *re-*  
*ported* to the king. *Nehemiah vi. 7.*  
Timotheus was well *reported* of by the brethren. *Acts xvi.*

Approving ourselves as the ministers of God, by honour and dishonour, by evil *report* and good *report*. *2 Corinthians iv.*

Is it upon record? or else *reported* successively from age to age? *Shakspeare. Richard III.*

My body's marked  
With Roman swords; and my *report* was once  
First with the best of note. *Id. Cymbeline.*  
There she appeared; or my *reporter* devised well for her. *Shakspeare.*

Others say, thou dost deserve; and I  
Believe it better than *reportingly*. *Id.*  
In Ticinum is a church with windows only from above, that *reporteth* the voice thirteen times, if you stand by the close end wall over against the door. *Bacon.*

The stronger species drowneth the lesser: the *report* of an ordinance the voice. *Id. Natural History.*

Rumours were raised of great discord among the nobility; for this cause the lords assembled gave order to apprehend the *reporters* of these surmises. *Hayward.*

Sea nymphs enter with the swelling tide;  
From Thetis sent as spies to make *report*,  
And tell the wonders of her sovereign's court. *Waller.*

The lashing billows make a long *report*,  
And beat her sides. *Dryden's Ceyx and Alcyone.*

If I had known a thing they concealed, I should never be the *reporter* of it. *Pope.*

After a man has studied the general principles of the law, reading the *reports* of adjudged cases will richly improve his mind. *Watts.*

**REPOSE, v. a. & v. n. }** Lat. *repono*. To **REPOSAL, n. s.** } lay to rest; lodge; place as in confidence; to rest; sleep: the rest or sleep taken; confidence placed; cause of rest

reposal, the act of reposing.

Dost thou think,  
If I would stand against thee, would the *reposal*  
Of any trust, virtue, or worth in thee,  
Make thy words faith'd? *Shakspeare.*

Rome's readiest champions, *repose* you here,  
Secure from wordly chances and mishaps;  
Here lurks no treason, here no envy swells. *Id.*  
And, for the ways are dangerous to pass,

I do desire thy worthy company,  
 Upon whose faith and honour I repose. *Id.*  
 Within a thicket I reposed; when round  
 I ruffled up fall'n leaves in heap; and found,  
 Let fall from heaven, a sleep interminate. *Chapman.*  
 I say nothing of thy hid treasures, which thy wis-  
 dom hath reposed in the bowels of the earth and sea.  
*Bp. Hall.*

Have ye chosen this place,  
 After the toil of battle, to repose  
 Your wearied virtue? *Milton's Paradise Lost.*  
 I repose upon your management, what is dearest  
 to me, my fame. *Dryden's Preface to Annus Mirab.*  
 After great lights must be great shadows, which  
 we call reposes; because in reality the sight would  
 be tired, if attracted by a continuity of glittering ob-  
 jects. *Id. Dufresnoy.*

I all the livelong day  
 Consume in meditation deep, recluse  
 From human converse; nor at shut of eve  
 Enjoy repose. *Philips.*  
 Pebbles, reposed in those cliffs amongst the earth,  
 being not so dissoluble and more bulky, are left be-  
 hind. *Woodward.*

That prince was conscious of his own integrity in  
 the service of God, and relied on this as a founda-  
 tion for that trust he reposed in him, to deliver him  
 out of his distresses. *Rogers.*

REPOSITE, *v. a.* } Lat. *repositus*. To lay  
 REPOSIT'ION, *n. s.* } up; lodge as in a place  
 REPOS'ITORY. } of safety; act of so-  
 lodging or of replacing; the place of deposit.

The mind of man not being capable of having  
 many ideas under view at once, it was necessary to  
 have a repository to lay up those ideas. *Locke.*

He can take a body to pieces, and dispose of them,  
 to us not without the appearance of irretrievable  
 confusion, but with respect to his own knowledge  
 into the most regular and methodical repositories.  
*Rogers's Sermons.*

Others reposit their young in holes, and secure  
 themselves also therein, because such security is  
 wanting, their lives being sought. *Derham.*

REPOSSESS', *v. a.* Re and possess. To  
 possess again.

How comes it now, that almost all that realm is  
 repossessed of them? *Spenser's State of Ireland.*  
 Her suit is now to repossess those lands,  
 Which we in justice cannot well deny. *Shakspeare.*  
 Nor shall my father repossess the land,  
 The father's fortune never to return.  
*Pope's Odyssey.*

REPHEHND', *v. a.* } Lat. *repre-*  
 REPHEHND'ER, *n. s.* } *hendo*. To re-  
 REPHEHNS'IBLE, *adj.* } prove; chide;  
 REPHEHNS'IBLENESS, *n. s.* } blame; detect or  
 REPHEHNS'IBLY, *adv.* } charge with fault;  
 REPHEHNS'ION, *n. s.* } the derivatives  
 REPHEHNS'IVE, *adj.* } all correspond-

ing.  
 All as before his sight, whose presence to offend  
 with any the least unseemliness, we would be surely  
 as loth' as they, who most reprehend or deuide that  
 we do. *Hooker.*

These fervent reprehenders of things, established  
 by public authority, are always confident and bold-  
 spirited men. *Id.*

Pardon me for reprehending thee,  
 For thou hast done a charitable deed. *Shakspeare.*

They like dumb statues stared;  
 Which when I saw, I reprehended them;  
 And asked the mayor, what meant this wilful si-  
 lence? *Id.*

This color will be reprehended or encountered, by  
 imputing to all excellencies in compositions a kind of  
 poverty. *Bacon.*

To a heart fully resolute, council is tedious, but  
 reprehension is loathsome. *Id.*

He could not reprehend the fight, so many strewed  
 the ground. *Chapman.*

The admonitions, fraternal or paternal, of his fel-  
 low christians, or the governors of the church; then  
 more public reprehensions and increpations.  
*Hammond.*

I nor advise, nor reprehend the choice  
 Of Marclely-hill. *Philips.*

What effect can that man hope from his most ze-  
 alous reprehensions, who lays himself open to recrimi-  
 nation? *Government of the Tongue.*

REPRESENT', *v. a.* } Fr. *représenter*; Lat  
 REPRESENT'ATION, } *represento*. To exh-  
 REPRESENTATIVE, } bit; describe; show;  
 REPRESENT'ER, } a representative is one  
 REPRESENTMENT. } bearing a delegated  
 character or power: the other derivatives cor-  
 responding with the verb.

One of his cardinals admonished him against that  
 unskilful piece of ingenuity, by representing to him,  
 that no reformation could be made, which would not  
 notably diminish the rents of the church.

When it is blessed, some believe it to be the na-  
 tural body of Christ; others, the blessings of Christ,  
 his passion in representation, and his grace in real  
 exhibition. *Decay of Piety.*  
*Taylor.*

Before him burn  
 Seven lamps, as in a zodiac representing  
 The heavenly fires. *Milton's Paradise Lost.*

Where the real works of nature, or veritable acts  
 of story, are to be described, art being but the imi-  
 tator or secondary representer, must not vary from the  
 verity. *Broune.*

We have met with some, whose reals made good  
 their representations. *Id. Vulgar Errors.*

If images are worshipped, it must be as gods,  
 which Celsus denied, or as representations of God;  
 which cannot be, because God is invisible and incor-  
 poreal. *Stillingfleet.*

Difficulty must cumber this doctrine, which sup-  
 poses that the perfections of God are the representa-  
 tives to us of whatever we perceive in the creatures.  
*Locke.*

This bank is thought the greatest load on the  
 Genoese, and the managers of it have been repre-  
 sented as a second kind of senate. *Addison.*

A statue of rumour whispering an idiot in the ear,  
 who was the representative of credulity.  
*Id. Freeholder.*

They relieve themselves with this distinction, and  
 yet own the legal sacrifices, though representative, to  
 be proper and real. *Atterbury.*

This council of four hundred was chosen, one  
 hundred out of each tribe, and seems to have been a  
 body representative of the people; though the people  
 collective reserved a share of power. *Swift.*

My muse officious ventures  
 On the nation's representers. *Id.*

REPRESS', *v. a. & n. s.* } Lat. *repressus*;  
 REPRES'SION, *n. s.* } Fr. *reprimer*. To  
 REPRES'SIVE, *adj.* } crush; put down;  
 subdue: act of repressing; repressive is the bet-  
 ter word for this last sense.

Discontents and ill blood having used always to  
 repress and appease in person, he was loth they  
 should find him beyond sea. *Bacon's Henry VII.*

Some, taking dangers to be the only remedy against

dringers, endeavoured to set up the sedition again; but they were speedily repressed, and thereby the sedition suppressed wholly. *Huyward.*

No declaration from myself could take place, for the due repression of these tumults. *King Charles.*

How can I

Repress the horror of my thoughts, which fly  
The sad remembrance? *Denham.*

Such kings

Favour the innocent, repress the bold.

Aud, while they flourish, make an age of gold.

*Waller.*

Loud outcries of injury, when they tend nothing to the repress of it, is a liberty rather assumed by rage and impatience than authorised by justice.

*Government of the Tongue.*

Thus long succeeding critics justly reigned,

Licence repressed, and useful laws ordained:

Learning and Rome alike in empire grew. *Pope.*

REPRIEVE, *v. a. & n. s.* Fr. *reprendre*, *re-primis*; Lat. *re* and *privo*. To respite; to give a respite; particularly from a sentence of death: the respite given.

He cannot thrive,

Unless her prayers, whom heaven delights to hear,  
And loves to grant, repress him from the wrath  
Of greatest justice. *Shakspeare.*

I hope it is some pardon or reprieve

For Claudio. *Id. Measure for Measure.*

All that I ask is but a short reprieve,

Till I forget to love, and learn to grieve. *Denham.*

The morning Sir John Hotham was to die, a reprieve was sent to suspend the execution for three days. *Clarendon.*

Company, though it may reprieve a man from his melancholy, yet cannot secure him from his conscience. *South.*

Having been condemned for his part in the late rebellion, his majesty had been pleased to reprieve him, with several of his friends, in order to give them their lives. *Addison.*

He reprieves the sinner from time to time, and continues and heaps on him the favours of his providence, in hopes that, by an act of clemency so undeserved, he may prevail on his gratitude and repentance. *Rogers's Sermons.*

REPRIEVE, in criminal law (from Fr. *reprendre*, *i. e.* to take back), is the withdrawing of a sentence for an interval of time; whereby the execution is suspended. This, says judge Blackstone, may be, first, *ex arbitrio judicis*, either before or after judgment: as, where the judge is not satisfied with the verdict, or the evidence is suspicious, or the indictment is insufficient, or he is doubtful whether the offence be within clergy; or sometimes if it be a small felony, or any favorable circumstances appear in the criminal's character, to give time to apply to the crown for either an absolute or conditional pardon. These reprieves may be granted or taken off by the justices of gaol-delivery, although their session be finished, but this rather by usage than of right. Reprieves may also be *ex necessitate legis*: as where a woman is capitally convicted, and pleads her pregnancy. Though this is no cause to stay judgment, yet it is to respite the execution till she be delivered. This is a mercy dictated by the law of nature, in *favorem prolis*; and therefore no part of the bloody proceedings in the reign of queen Mary I. hath been more justly detested than the cruelty exercised in the

VOL. XVIII.

island of Guernsey, of burning a woman big with child; and when, through the violence of the flames, the infant sprang forth at the stake, and was preserved by the by-standers, after some deliberations of the priests who assisted at the sacrifice, they cast it into the fire as a young heretic: a barbarity which they never learned from the laws of ancient Rome; which direct, with the same humanity as our own, *quod pregnantis mulieris damnata pena differatur quoad pariat*: which doctrine has also prevailed in England as early as the first memorials of the English law will reach. When this plea is made, in stay of execution, the judge must direct a jury of twelve matrons or discreet women to enquire into the fact; and if they bring in their verdict quick with child (for barely with child, unless it be alive in the womb, is not sufficient), execution shall be staid generally till the next session; and so, from session to session, till either she is delivered, or proves by the course of nature not to have been with child at all. But if she once hath had the benefit of this reprieve, and been delivered, and afterwards becomes pregnant again, she shall not be entitled to the benefit of a farther respite for that cause. For she may now be executed before the child is quick in the womb; and shall not, by her own incontinence, evade the sentence of justice. Another cause of regular reprieve is, if the offender become non compos between the judgment and the award of execution: for regularly, though a man be compos when he commits a capital crime, yet, if he become non compos after, he shall not be indicted; if after indictment, he shall not be convicted; if after conviction, he shall not receive judgment; if after judgment, he shall not be ordered for execution; for *furiouso solo furore punitur*; and the law knows not but he might have offered some reason, if in his senses, to have stayed these respective proceedings. It is therefore an invariable rule when any time intervenes between the attainer and the award of execution, to demand of the prisoner what he hath to allege why execution should not be awarded against him; and, if he appears to be insane, the judge in his discretion may and ought to reprieve him. Or the party may plead, in bar of execution, either pregnancy, the king's pardon, an act of grace, or diversity of person, viz. that he is not the same that was attainted. In this last case a jury shall be impelled to try the identity of his person; and not whether guilty or innocent, for that has been decided before. And in these collateral issues the trial shall be instanter; and no time allowed the prisoner to make his defence or produce his witnesses, unless he will make oath that he is not the person attainted: neither shall any peremptory challenges of the jury be allowed the prisoner, though formerly such challenges were held to be allowable whenever a man's life was in question. If neither pregnancy, insanity, non-identity, nor other plea, will avail to avoid the judgment, and stay the execution consequent thereupon, the last and surest resort is in the king's most gracious pardon; the granting of which is the sole prerogative of the crown. See PARDON.

REPRIMAND, *v. a. & n. s.* Fr. *repriman-*

2 M

*der*; Lat. *reprimō*. To chide; check; reprehend; to reprove: reproof given.

He enquires how such an one's son and wife do, whom he has not seen at church; which is understood as a secret *reprimand* to the person absent.

*Addison's Spectator.*

Germanicus was severely *reprimanded* by Tiberius, for travelling into Egypt without his permission.

*Arbutnot.*

They saw their eldest sister once brought to her tears, and her perverseness severely *reprimanded*.

*Law.*

**REPRINT**, *v. a.* Re and print. To print again; to renew the impression of any thing.

The business of redemption is to rub over the defaced copy of creation, to *reprint* God's image upon the soul, and to set forth nature in a second and a fairer edition.

*South.*

My bookseller is *reprinting* the Essay on Criticism.

*Pope.*

**REPRISE**, *n. s.* } Fr. *reprise*. The act of **REPRI'SAL**. } taking something in retaliation of injury: the thing taken.

The English had great advantage in value of *reprisals*, as being more strong and active at sea.

*Hayward.*

Your care about your banks infers a fear Of threatening floods and inundations near; If so, a just *reprise* would only be Of what the land usurped upon the sea.

*Dryden.*

Sense must sure thy safest plunder be, Since no *reprisals* can be made on thee.

*Dorset.*

**REPRISAL**, or **RECAPTION**, is a species of remedy allowed to an injured person. This happens when any one hath deprived another of his property in goods or chattels personal, or wrongfully detains one's wife, child, or servant: in which case the owner of the goods, and the husband, parent, or master, may lawfully claim and retake them, wherever he happens to find them; so it be not in a riotous manner, or attended with a breach of the peace. The reason is, that it may often happen that the owner may have this only opportunity of doing himself justice: his goods may be afterwards conveyed away or destroyed, and his wife, children, or servants, concealed or carried out of his reach, if he had no speedier remedy than the ordinary process of law. If therefore he can gain possession of his property again, without force or terror, the law will justify his proceeding. But, as the public peace is a superior consideration to any one man's private property, it is provided that this natural right of recaption shall never be exerted where such exertion must occasion strife and bodily contention, or endanger the peace of society. In such cases the loser must have recourse to an action at law.

**REPROACH**, *v. a. & n. s.* } Fr. and Span. **REPROACH'ABLE**, *adj.* } *reproche*, of Lat. **REPROACH'FUL**, } *reprobatio*. To **REPROACH'FULLY**, *adv.* } censure opprobriously; upbraid: the adjectives and noun substantive corresponding.

I will that the younger women marry, and give none occasion to the adversary to speak *reproachfully*.

1 *Timothy* v. 14.

If ye be *reproached* for the name of Christ, happy are ye.

1 *Peter* iv. 14.

With his *reproach* and odious menace, The knight emboiling in his haughty heart, Knit all his forces.

*Spenser.*

If black scandal or foul-faced *reproach* Attend the sequel of your imposition, Your mere enforcement shall acquaintance me.

*Shakspeare.*

O monstrous! what *reproachful* words are these!

*Id.*

Shall I then be used *reproachfully*?

*Id.*

To make religion a stratagem to undermine government is contrary to this superstructure, most scandalous and *reproachful* to Christianity.

*Hammond.*

That shame

There sit not, and *reproach* us as unclean.

*Milton.*

Thy punishment

He shall endure, by coming in the flesh

To a *reproachful* life and cursed death.

*Id.*

The French writers do not burthen themselves too much with plot, which has been *reproached* to them as a fault.

*Dryden.*

An advocate may be punished for *reproachful* language in respect of the parties in suit.

*Auliffe.*

The very regret of being surpassed in any valuable quality, by a person of the same abilities with our selves, will *reproach* our own laziness, and even shame us into imitation.

*Rogers.*

To be idle and to be poor have always been *reproaches*, and therefore every man endeavours with his utmost care to hide his poverty from others, and his idleness from himself.

*Johnson.*

**REPROBATE**, *adj., n. s., &* } Lat. *repro-*

**REPROBATION**, *n. s.* } [*v. a.* & *bus.* Lost to

virtue or to grace; abandoned: the noun substantive corresponding.

They profess to know God, but in works deny him, being abominable, and to every good work *reprobate*.

*Titus* i. 16.

What if we omit

This *reprobate*, till he were well inclined!

*Shakspeare.*

This sight will make him do a desperate turn, Yea curse his better angel from his side, And fall to *reprobation*.

*Id. Othello.*

I acknowledge myself for a *reprobate*, a villain, a traitor to the king, and the most unworthy man that ever lived.

*Raleigh.*

What should make it necessary for him to repent and amend, who either without respect to any degree of amendment is supposed to be elected to eternal bliss, or, without respect to sin, to be irreversibly *reprobated*?

*Hammond.*

All the saints have profited by tribulations; and they that could not bear temptations became *reprobates*.

*Taylor.*

God, upon a true repentance, is not so fatally tied to the spindle of absolute *reprobation* as not to keep his promise, and seal merciful pardons.

*Maine.*

Strength and art are easily outdone

By spirits *reprobate*.

*Milton.*

You are empowered to give the final decision of wit, to put your stamp on all that ought to pass for current, and set a brand of *reprobation* on clipt poetry and false coin.

*Dryden.*

A *reprobated* hardness of heart does them the office of philosophy towards a contempt of death.

*L' Estrange.*

God forbid, that every single commission of a sin, though great for its kind, and withal acted against conscience for its aggravation, should so far deprave the soul, and bring it to such a *reprobate* condition, as to take pleasure in other men's sins.

*South.*

Such an answer as this is *reprobated* and disallowed of in law; I do not believe it, unless the deed appears. *Ayliffe.*

Drive him out

To *reprobated* exile round the world, A cautive vagabond, abhorred, accursed. *Southern.*  
If there is any poor man or woman, that is more than ordinarily wicked and *reprobate*, Miranda has her eye upon them. *Law.*

REPROBATION, in theology, is applied to that decree or resolve which God hath taken from all eternity to punish sinners who shall die in impenitence. This opinion was adopted by St. Augustine and other fathers; as well as by Calvin and most of his followers. The church of England, in the thirty-nine articles, teaches something like it; and the church of Scotland, in the confession of faith, maintains it. Reprobation respects angels as well as men, and respects the latter either fallen or unfallen. See PREDESTINATION.

REPRODUCE, *v. a.* } Fr. *reproduire*; re  
REPRODUCTION, *n. s.* } and produce. To produce again or anew: the act of doing so, or thing produced.

If horse dung *reproduceth* oats, it will not be easily determined where the power of generation ceaseth. *Browne.*

am about to attempt a *reproduction* in vitriol, in which it seems not unlikely to be performable. *Boyle.*

Those colours are unchangeable, and, whenever all those rays with those their colours are mixed again, they *reproduce* the same white light as before. *Newton's Opticks.*

REPROVE, *v. a.* } Fr. *reprover*; re and  
REPROVABLE, *adj.* } prove. To refute; con-  
REPROVER, *n. s.* } vince; blame to the face;  
REPROOF. } reprehend; blame for:  
reprovable is, culpable; blameable: reprove, he who reproves: reproof, blame to the face; reprehension; censure.

For Crist pleside not to hymself as it is writun, the *reproves* of men, dispisyng the felden on me. *Wiclif. Romaynes.*

I will not *reprove* thee for thy sacrifices. *Psalm 1. 8.*

He shall *reprove* the world of sin and of righteousness. *St. John.*

*Reprove*, rebuke, exhort. 2 *Tim. iv. 2.*

This is the sin of the minister, when men are called to *reprove* sin, and do not. *Perkins.*

What if they can better be content with one that can wink at their faults, than with him that will *reprove* them? *Whitgift.*

There is no slander in an allowed fool, though he do nothing but rail; nor no railing in a known discreet man, though he do nothing but *reprove*. *Shakspeare.*

My lords,  
*Reprove* my allegation if you can. *Id.*

Good Sir John, as you have one eye upon my follies, turn another into the register of your own, that I may pass with a *reproof* the easier. *Id. Merry Wives of Windsor.*

You *reprove* one of laziness, they will say, dost thou make idle a coat? that is, a coat for idleness. *Carew.*

Next to the not deserving a *reproof* is the well taking of it. *Bp. Hall's Contemplations.*

If thou dost find thy faith as dead after the reception of the sacrament as before, it may be thy faith was not only little, but *reprovable*. *Taylor.*

What if thy son

Prove disobedient, and, *reproved*, retort,  
Wherefore didst thou beget me? *Milton.*

This shall have from every one, even the *reprovers* of vice, the title of living well. *Locke.*

Let the most potent sinner speak out, and tell us, whether he can command down the clamours and revilings of a guilty conscience, and impose silence upon that bold *reprover*? *South.*

Fear not the anger of the wise to raise;  
Those best can bear *reproof*, who merit praise. *Pope.*

He *reproves*, exhorts, and preaches to those, for whom he first prays to God. *Law.*

Let my obedience then excuse

My disobedience now,

Nor some *reproof* yourself refuse

From your aggrieved Bow-wow. *Cowper.*

REPRUNE, *v. a.* Re and prune. To prune a second time.

*Reprune* apricots and peaches, saving as many of the young likeliest shoots as are well placed. *Evelyn's Kalendar.*

REPS, a district of Transylvania; inhabited by ancient Saxon families, and lying adjacent to the north-east corner of Fogaras. Its area is 210 square miles; population about 26,000. It is adapted partly for corn and partly for pasture; other tracts are covered with forests. The chief river is the Aluta.

REPS, or Kohalom, the chief place of the above district, a small neat town with 2200 inhabitants. Sixteen miles north of Fogaras.

REPTILE, *adj. & n. s.* Lat. *reptile*. Creeping upon many feet; an animal that so creeps. In Gay's lines reptile is confounded with serpent.

Terrestrial animals may be divided into quadrupeds or *reptiles* which have many feet, and serpents which have no feet. *Locke.*

Holy retreat! sithence no female hither,  
Conscious of social love and nature's rites,  
Must dare approach, from the inferior *reptile*,  
To woman, form divine. *Prior.*

Cleanse baits from filth, to give a tempting gloss,  
Cherish the sully'd *reptile* race with moss. *Gay.*

Ye proud and wealthy, let this theme

Teach humbler thoughts to you,

Since such a *reptile* has its gem,  
And boasts its splendour too. *Cowper.*

It is as if the dead could feel

The icy worm around them steal,

And shudder, as the *reptiles* creep

To revel o'er their rotting sleep,

Without the power to scare away

The cold consumers of their clay. *Byron.*

REPTILES, in zoology, the modern name among naturalists for the class of animals principally described by Linnæ as AMPHIBIA. See that article. The objections to this classification of the great Swedish naturalist seem well sustained. If we regard as amphibia all aquatic animals which are able to live for a time on land, or those land animals which can remain for a time under water, all animals are amphibious; for even man and most of the mammalia can dive. If, on the other hand, the word amphibious be taken etymologically, and understood to denote an equal power of subsisting in air and water, it is applicable to no class of animals. Although reptiles can remain longer under water than the mammalia, or birds, they are obliged, as their



respiratory organs are only calculated for breathing air, to come sooner or later to the surface; and they are drowned, like any warm-blooded animal, if detained in the water beyond that time. To enable an animal to exist equally in air and water it should have lungs and gills; that is, it should have the power of breathing air, like the mammalia and birds, and of breathing water, like fishes; and it should be able to use either of these methods, to the exclusion of the other. But we know of no such animals. The larvæ of frogs and salamanders, the proteus anguinus, and the siren lacentina, have indeed branchiæ and lungs; but, as far as our knowledge hitherto goes, none of these could live wholly out of water. The lungs of the tadpole, and of the larvæ of salamanders, are designed for the service of those animals in their subsequent stage of existence; but do not give them the power of living in air: and the lungs, either of the proteus or siren, do not seem sufficient to enable them to dispense with the office of the branchial appendages. Among his amphibia Linnæus places reptiles that never go into the water, and some fishes which never quit it. He could not fail to experience great difficulties in naming so ill-conceived a class: the genera comprehended are too ill-assorted to admit of their having a common name. Daubenton first divided them into two classes, naming one oviparous quadrupeds, and the other serpents. Lacépède adopted these two classes, and placed between them a third, that of oviparous bipeds. Hermann, in his *Tabulæ affinitatum Animalium*, proposed to substitute, for the term amphibia, that of cryerozoa. Cuvier rejects the Linnæan term for that of reptiles. See *ZOOLOGY*.

REPTON (Humphrey), a private gentleman, distinguished by his skill in the art of gardening, was a native of Bury, in Suffolk, where he was born in 1752. Having acquired the friendship of the late Mr. Windham, he in 1783 accompanied that gentleman to Ireland, and obtained a lucrative situation in the castle of Dublin: this, however, he shortly after gave up. On his return to London he applied himself to the improvement of gardens and pleasure grounds professionally, and published several works on landscape gardening. He died in 1818, leaving several sons, one of whom was married to a daughter of the earl of Eldon.

REPUBLIC, *n. s.* } Fr. *republique*;  
 REPUBLICAN, *adj. & n. s.* } Lat. *respublica*.  
 Commonwealth; common interest; state in which the power is lodged in more than one: republican, governed by the people; a person who holds the eligibility of this form of government.

Those that by their deeds will make it known,  
 Whose dignity they do sustain;  
 And life, state, glory, all they gain,  
 Count the *republic's*, not their own. *Ben Jonson*.

These people are more happy in imagination than the rest of their neighbours, because they think themselves so; though such a chimerical happiness is not peculiar to *republicans*. *Addison*.

They are indebted many millions more than their whole *republic* is worth. *Id. State of the War*.

REPUBLIC, or commonwealth a popular

state of government, or a nation where the people have the government in their own hands.

REPU'DIATE, *v. a.* Fr. *repudier*; Lat. *repudio*. To divorce; reject; put away.

Let not those that have *repudiated* the more inviting sins, shew themselves plighted and bewitched by this. *Government of the Tongue*.

It was allowed by the Athenians, only in case of *repudiation* of a wife. *Arbutnot on Coins*.

Here is a notorious instance of the folly of the atheists, that while they *repudiate* all title to the kingdom of heaven, merely for the present pleasure of body, and their boasted tranquillity of mind, besides the extreme madness in running such a desperate hazard after death, they unwittingly deplete themselves here of that very pleasure and tranquillity they seek for. *Bentley's Sermons*.

REPUGNANT, *adj.* } Fr. *repugnant*; Lat.  
 REPUGNANCY, *n. s.* } *repugnans*. Disobedi-  
 REPUGNANTLY, *adv.* } ent; contrary; oppo-  
 site; inconsistent: the noun substantive and ad-  
 verb corresponding.

But, where difference is without *repugnancy*, that which hath been can be no prejudice to that which is. *Hooker*.

There is no breach of a divine law, but is more or less *repugnant* unto the will of the law-giver, God himself. *Perkins*.

His antique sword,  
 Rebellious to his arm, lies where it falls,  
*Repugnant* to command. *Shakspeare. Hamlet*.

Why do fond men expose themselves to battle,  
 And let the foes quietly cut their throats,  
 Without *repugnancy*? *Id. Timon*.

They speak not *repugnantly* thereto. *Browne*.  
 That which causes us to lose most of our time,  
 is the *repugnance* which we naturally have to labour. *Dryden*.

Thus did the passions act without any of their present jars, combats, or *repugnancies*, all moving with the beauty of uniformity and the stillness of composure. *South's Sermons*.

Why I reject the other conjectures, is, because they have not due warrant from observation, but are clearly *repugnant* thereto. *Woodward*.

Your way is to wrest and strain some principles maintained both by them and me, to a sense *repugnant* with their other known doctrines. *Waterland*.

It is no affront to omnipotence, if, by reason of the formal incapacity and *repugnancy* of the thing, we aver that the world could not have been made from all eternity. *Bentley*.

REPU'LLULATE, *v. n.* Fr. *repulluler*; Lat. *re* and *pullulo*. To bud again.

Though tares *repullulate*, there is wheat still left in the field. *Hovel's Vocal Forest*.

REPULSE', *v. a. & n. s.* } Fr. *repulse*; Lat.  
 REPULSION, } *repulsio*. To beat  
 REPULSIVE, *adj.* } or drive back; the  
 being driven off or back from any attempt: *repulsion* is the act or power of repelling; the adjective corresponds.

The christian defendants still *repulsed* them with greater courage than they were able to assail them. *Knolles*.

This fleet, attempting St. Minoes, were *repulsed*, and, without glory or gain—returned unto England. *Hayward*.

My *repulse* at Hull seemed an act of so rude disloyalty, that my enemies had scarce confidence enough to abet it. *King Charles*.

By fate repelled and with repulses tired. *Denham.*  
 Man complete to have discovered and repulsed  
 Whatever wiles of foe or seeming friend. *Milton.*

The parts of the salt or vitriol recede from one another, and endeavour to expand themselves, and remove as far asunder as the quantity of water, in which they float, will allow; and does not this endeavour imply, that they have a repulse force by which they fly from one another, or that they attract the water more strongly than one another?

*Newton's Optics.*

Air has some degree of tenacity, whereby the parts attract one another; at the same time, by their elasticity, the particles of air have a power of repulsion or flying off from one another. *Arbuthnot.*

REPULSION, in physics, is that property of bodies whereby they recede from each other, and, on certain occasions, mutually avoid coming into contact. This, as well as attraction, has been considered as one of the primary qualities of all matter, and been much used in explaining the phenomena of nature; thus the particles of air, fire, steam, electric fluid, &c., have all been said to have a repulsive power with respect to one another; because, when they are compressed into a small space, they expand with great force; but as to fire, light, and electricity, our experiments fail; nay, the supposition of a repulsive power among the particles of the electric fluid is at least a moot point. See ELECTRICITY. Even in those fluids air and steam, where a repulsive power manifestly exists, it is demonstrable that the repulsion cannot be a primary quality, since it can be increased to a great degree by heat, and diminished by cold; but it is impossible that a primary quality of matter can be increased or diminished by any external circumstances whatever. The repulsion of electrified bodies is explained under the article ELECTRICITY; that of others is less subject to investigation; and the most that can be said of it is, that in many cases it seems to be the consequence of a modification of heat, as in others of electricity.

REPURCHASE, *v. a.* Re and purchase. To buy again.

Once more we sit on England's royal throne,  
 Repurchased with the blood of enemies;  
 What valiant foe-men, like to autumn's corn,  
 Have we mowed down in top of all their pride!

*Shakspeare.*

If the son alien those lands, and repurchase them again in fee, the rules of descents are to be observed, as if he were the original purchaser. *Hale.*

REPUTE', *v. a. & n. s.* } *Fr. repeter; Lat.*  
 REPUTABLE, *adj.* } *reputo.* To hold;  
 REPUTABLENESS, *n. s.* } think; account; es-  
 REPUTABLY, *adv.* } teem: hence, as a  
 REPUTATION, *n. s.* } noun substantive,  
 REPUTE'LESS, *adj.* } character; establish-  
 ed character or opinion; credit; honor: the last, or the meaning of repute, noun substantive, being also that of reputation: reputable, is of good repute; honorable: the noun substantive and adverb following corresponding: reputeless, disreputable; disgraceful.

The king was reputed a prince most prudent.

*Shakspeare.*

Reputation is an idle and most false imposition; oft got without merit, and lost without deserving:

you have lost no reputation at all, unless you repute yourself such a loser. *Id.*

Opinion, that did help me to the crown,

Had left me in reputeless banishment,

A fellow of no mark nor livelihood. *Id.*

Men, such as chuse

Law practice for mere gain, boldly repute

Worse than embrothel'd strumpets prostitute. *Donne.*

He who reigns

Monarch in heaven, till then, as one secure,

Sat on his throne, upheld by old repute. *Milton.*

If the great vizier be so great, as he is reputed, in politics, he will never consent to an invasion of Hungary. *Temple.*

Versoy, upon the lake of Geneva, has the reputation of being extremely poor and beggarly. *Addison.*

If ever any vice shall become reputable, and be glorified in as a mark of greatness, what can we then expect from the man of honour, but to signalize himself! *Rogers's Sermons.*

To many such worthy magistrates, who have thus reputably filled the chief seats of power in this great city, I am now addressing my discourse. *Atterbury's Sermons.*

A third interprets motions, looks, and eyes;

At every word a reputation dies. *Pope.*

In the article of danger, it is as reputable to elude an enemy as defeat one. *Broome.*

REQUENA, a trading town of Cuença, in Spain, on the border of Valencia. Its inhabitants, about 6000, are largely engaged in the manufacture of silks.

REQUEST', *n. s. & v. a.* *Fr. requeste; Lat. requisitus.* Petition; entreaty; solicitation; demand; state of being desired; hence repute; credit: to request is to ask; entreat; solicit.

Haman stood up to make request for his life to Esther. *Ether.*

It was to be requested of Almighty God, by prayer, that those kings would seriously fulfil all that hope of peace. *Knolles.*

But ask what you would have reformed,  
 I will both hear and grant you your requests. *Shakspeare.*

Aufidius will appear well in these wars, his great opposer Coriolanus being now in no request of his country. *Id.*

Ask him to lend

To this, the last request that I shall send,

A gentle ear. *Denham.*

All thy request for man, accepted son!

Obtain; all thy request was my decree. *Milton.*

Whilst this vanity of thinking, that men are obliged to write either systems or nothing, is in request, many excellent notions are suppressed. *Boyle.*

Knowledge and fame were in as great request as wealth among us now. *Temple.*

In things not unlawful great persons cannot be properly said to request, because, all things considered, they must not be denied. *South's Sermons.*

REQUESTS, COURT OF (curia requisitionum), was a court of equity, of the same nature with the court of chancery, but inferior to it; principally instituted for the relief of such petitioners as in conscionable cases addressed themselves by supplication to his majesty. Of this court the lord privy-seal was chief judge, assisted by the masters of request. It began about the 9 Hen. VII., according to Sir Julius's Cæsar's trac-

tate upon this subject; though Mr. Gwyn asserts that it began from a commission first granted by Henry VIII. This court having assumed great power to itself, so that it became burthen-some, Mich. Anno 40 and 41 Eliz. in the court of common pleas it was adjudged upon solemn argument, that the court of requests was no court of judicature, &c., and by statute 16 & 17 Car. I. c. 10, it was taken away. There are still however courts of requests, or more properly courts of conscience, constituted in London and other trading and populous districts for the recovery of small debts. The first of these was established in London at so early a period as the reign of Henry VIII. by an act of their common council; which, however, was certainly insufficient for that purpose, and illegal, till confirmed by stat. 3 Jac. I. c. 15, which has since been explained and amended by stat. 14 Geo. II. c. 10. The constitution is this: two aldermen and four commoners sit twice a week to hear all causes of debt not exceeding the value of 40s., which they examine in a summary way, by the oath of the parties or other witnesses, and make such order therein as is consonant to equity and good conscience. The time and expense of obtaining this summary redress are very inconsiderable, which makes it a great benefit to trade; and thereupon divers trading towns and other districts have obtained acts of parliament for establishing in them courts of conscience upon nearly the same plan as that of London. By 25 Geo. III. c. 45, which is confined to prosecutions in courts of conscience in London, Middlesex, and the borough of Southwark, and by 26 Geo. III. c. 38, which extends the provisions of the former act to all other courts instituted for the recovery of small debts, it is enacted that, after the 1st day of September 1786, no person whoseever being a debtor or defendant, and who has been or shall be committed to any gaol or prison by order of any court or commissioners authorised by any act or acts of parliament for constituting or regulating any court or courts for the recovery of small debts, where the debt does not exceed 20s., shall be kept or continued in custody, on any pretence whatsoever, more than twenty days from the commencement of the last mentioned act; or from the time of his, her, or their commitment to prison; and, where the original debt does not amount to or exceed the sum of 40s., more than forty days from the commencement of the said act, or from the time of his, her, or their commitment as aforesaid; and all jailers are thereby required to discharge such persons accordingly. And by sect. 2, if it shall be proved to the satisfaction of the court that any such debtor has money or goods, which he has wilfully and fraudulently concealed, the court shall have power to enlarge the aforesaid time of imprisonment for debts under 20s. to any time not exceeding thirty days, and for debts under 40s. to any time not exceeding sixty days; which said ground of farther detention shall be specified in the said commitment. And that (by sect. 3) at the expiration of the said respective times of imprisonment, every such person shall immediately be discharged, without paying any sum of money, or other reward or gratuity what-

soever, to the jailer of such jail on any pretence whatsoever; and every jailer demanding or receiving any fee for the discharge of any such person, or keeping any such person prisoner after the said respective times limited by the said act, shall forfeit £5, to be recovered in a summary way before two justices of the peace; one moiety hereof to be paid to the overseers of the poor of the parish where the offence shall be committed, and the other to the informer.

**REQUICK'EN, v. a.** Re and quicken. To reanimate.

By and by the din of war 'gan pierce  
His ready sense, when straight his doubled spirit  
*Requickened* what in flesh was fatigate,  
And to the battle came he. *Shakspeare. Coriolanus.*

**RE'QUIEM, n. s.** Lat. *requiem*. A hymn in which they implore rest for the dead.

The midwife kneeled at my mother's throes,  
With pain produced and nursed for future woes;  
Else had I an eternal *requiem* kept,  
And in the arms of peace for ever slept. *Sandys.*

We should profane the service of the dead,  
To sing a *requiem* and such peace to her,  
As to peace-parted souls. *Shakspeare.*

**REQUIRE, v. a.** } Fr. *requirer*; Lat.  
**REQUIR'ABLE, adj.** } *requiro, requisitus.*  
**RE'QUISITE, adj. & n. s.** } To demand; ask  
**RE'QUISITELY, adv.** } as of right; enjoin;  
**RE'QUISITENESS, n. s.** } make or show necessary; need: the adjective corresponding to requisite is, necessary; needful; naturally required: the adverb and noun substantive corresponding.

The king's business *required* haste. *1 Samuel.*  
Ye me *requires*

A thing without the compass of my wit;  
For both the lineage and the certain sire,  
From which I sprung, are from me hidden yet. *Spenser.*

We do *require* them of you, so to use them,  
As we shall find their merits. *Shakspeare.*  
Cold calleth the spirits to succour, and therefore  
they cannot so well close and go together in the  
head, which is ever *requiute* to sleep. *Bacon.*

This the very law of nature teacheth us to do,  
and this the law of God *requireth* also at our hands. *Spelman.*

This implied

Subjection, but *required* with gentle sway. *Milton.*  
High from the ground, the branches would *require*  
Thy utmost reach. *Id.*

It contains the certain periods of times, and all circumstances *requirable* in a history to inform. *Hals.*

Discerning how exquisitely the several parts of scripture are fitted to the several times, persons, and occurrences intended, we shall discover not only the sense of the obscurer passages, but the *requisiteness* of their having been written so obscurely. *Boyle.*

Of our alliance other lands desired,  
And what we seek of you, of us *required*. *Dryden*  
But why, alas! do mortal men complain?

God gives us what he knows our wants *require*,  
And better things than those which we desire. *Id.*  
Res non parva labore, sed relicta, was thought by a poet to be one of the *requisites* to a happy life. *Id.*

God, when he gave the world in common to mankind, commanded man also to labour; and the penalty of his condition *required* it. *Locke.*

When God new-modelled the world by the introduction of a new religion, and that in the room of

one set up by himself, it was *requisite* that he should recommend it to the reasons of men with the same authority and evidence that enforced the former.

*South.*

God on his part has declared the *requisites* on ours; what we must do to obtain blessings is the great business of us all to know.

*Wake.*

**REQUIRE', v. a.** } *Fr. requirer.* To repay; **REQUITAL, n. s.** } retaliate; recompense: requital is, return of any good or bad office; retaliation; reward.

When Joseph's brethren saw that their father was dead, they said, Joseph will *requite* us all the evil we did.

*Genesis.*

An avenger against his enemies, and one that shall *requite* kindness to his friends.

*Eccles.*

Should we take the quarrel of sermons in hand, and revenge their cause by *requital*, thrusting prayer in a manner out of doors under colour of long preaching?

*Hooker.*

Since you

Wear out your gentle limbs in my affairs,  
Be bold, you do so grow in my *requital*,  
As nothing can unroot you.

*Shakspeare.*

If he love me to madness, I shall never *requite* him.

*Id.*

I have ta'en a cordial,  
Sent by the king of Haly in *requital*  
Of all my miseries, to make me happy.

*Denham.*

He asked me for a song,  
And in *requital* op'd his leathern scrip,  
And shewed me simples of a thousand names,  
Telling their strange and vigorous faculties.

*Milton.*

Him within protect from harms;  
He can *requite* thee for he knows the charms  
That call fame on such gentle acts as these.

*Id.*

No merit their aversion can remove,  
Nor ill *requital* can efface their love.

*Waller.*

In all the light that the heavens bestow upon this lower world, though the lower world cannot equal their benefaction, yet with a kind of grateful return it reflects those rays, that it cannot recompense; so that there is some return however, though there can be no *requital*.

*South's Sermons.*

Great idol of mankind we neither claim  
The praise of merit, nor aspire to fame!  
'Tis all we beg thee to conceal from sight  
Those acts of goodness which themselves *requite*:  
O let us still the secret joy partake,  
To follow virtue ev'n for virtue's sake.

*Pope.*

Unhappy Wallace,  
Great patriot hero! ill *requited* chief!

*Thon son.*

**RESALE', n. s.** Re and sale. Sale at second hand.

Monopolies and coemption of wares for *resale*, where they are not restrained, are great means to enrich.

*Bacon.*

**RESALUTE', v. a.** *Fr. resaluer*; *Lat. resaluto.* To salute or greet anew.

We drew her up to land,  
And trod ourselves the *resaluted* sand.

*Chayman.*

To *resalute* the world with sacred light,  
Leucothea waked.

*Milton.*

**RESAIL', v. n.** Re and sail. To sail back.  
From Pyle *resailing*, and the Spartan court,  
Horrid to speak! in ambush is decreed.

*Pope.*

**RESCIND', v. a.** } *Fr. rescinder*; *I. at. rescission, n. s.* } *scindo.* To cut off; abrogate: the act of cutting off; abrogation.

If any infer *rescission* of their estate to have been for idolatry, that the governments of all idolatrous nations should be also dissolved, it followeth not.

*Bacon.*

It is the imposing a sacramental obligation upon him, which being the condition, upon the performance whereof all the promises of endless bliss are made over, it is not possible to *rescind* or disclaim the standing obliged by it.

*Hammond.*

I spake against the test, but was not heard;  
These to *rescind*, and peerage to restore.

*Dryden.*

**RESCOUS, or RESCUE (RESCUSSUS), in law,** an illegal taking away, and setting at liberty, a distress taken, or a person arrested, by process, or course of law. This is properly a *rescous* in fact. If one distrains beasts for damage feasant in his ground, and, as he drives them along the highway towards the pound, they enter into the owner's house, and he withholds them there, and will not deliver them upon demand; this detainer is a *rescous* in law. For a *rescous*, or the taking of goods by force, when, in a distress, they are in the custody of the law, is considered as an atrocious injury. The distrainer may bring an action on the case for this injury, and shall therein, if the distress were taken for rent, recover treble damages. In case of the forcible delivery of a person arrested from the officer who is taking him to prison, the plaintiff has a similar remedy by action on the case, or of *rescous*; or, if the sheriff makes a return to such *rescous* to the court out of which the process issued, the rescuer will be punished by attachment.

**RESCRIBE', v. a.** } *Fr. rescrire*; *Lat. rescript, n. s.* } *scribo.* To write back, or return in writing; transcribe: a *rescript* is an edict of some sovereign authority.

One finding a great mass of money digged under ground, and, being somewhat doubtful, signified it to the emperor, who made a *rescript* thus: Use it.

*Bacon's Apophthegms.*

Calling for more paper to *rescribe* them, he shewed him the difference betwixt the ink-box and the sand-box.

*Hewel.*

Whenever a prince on his being consulted *rescribes* or writes back *Toleramus*, he dispenses with that act otherwise unlawful.

*Auliffé's Parergon.*

The popes, in such cases where canons were silent, did, after the manner of the Roman emperors, write back their determinations, which were stiled *rescripts* or decretal epistles, having the force of laws.

*Id.*

**RESIPT, in the civil law,** is a judgment delivered by an emperor or pope on some difficult question or point of law, to serve as a decision thereof for the future. The papal *rescripts* never obtained either in England or France, when contrary to the liberties of the English and Gallican churches; but were declared abusive. Among the ancient Romans the contending parties, and even the magistrates themselves, frequently consulted the emperor on the measures they were to take in certain difficult cases; and the answers returned by the emperor on such consultations were called *rescripts*. These had not, indeed, the full force of laws; but they were deemed a strong prejudice or presumption: and in succeeding ages they had the force of perpetual laws.

Justinian has inserted a great number of *rescripts* in the code; and by that means given them the authority they would otherwise want. The author of the life of the emperor Macrinus observes, of that prince, that he would have his officers judge by laws, not by *rescripts*; esteem-

ing it absurd to admit the wills of ignorant men, such as Commodus and Caracalla, for rules of judging; and Trajan never gave any rescripts at all, being loth to countenance a custom, where what was frequently granted as a favor, in particular cases, might be afterwards pleaded as a precedent.

**RESCUE**, *v. a. & n. s.* Old Fr. *rescorre*; Lat. *re exarsus*? To set free from violence, restraint, or danger: deliverance from a state of this kind.

Sir Scudamore, after long sorrow, in the end met with Britomartis, who succoured him and *reskewed* his love. *Spenser.*

My uncles both are slain in *rescuing* me. *Shakspeare.*

We're beset with thieves;  
*Rescue* thy mistress, if thou be a man. *Id.*

How comes it, you  
Have help to make this *rescue*? *Id.*

He that is so sure of his particular election as to resolve he can never fall, if he commit those acts against which scripture is plain that they that do them shall not inherit eternal life, must necessarily resolve that nothing but the removing his fundamental error can *res:ue* him from the superstructure.

*Hammond's Fundamentals.*

Dr. Bancroft understood the church excellently, and had almost *rescued* it out of the hands of the Calvinian party. *Clarendon.*

Who was that just man, whom had not heaven  
*Rescued*, had in his righteousness been lost? *Milton.*

Riches cannot *rescue* from the grave,  
Which claims alike the monarch and the slave. *Dryden.*

We have never yet heard of a tumult raised to *rescue* a minister whom his master desired to bring to a fair account. *Davenant.*

**RESEARCH**, *n. s. & v. n.* Fr. *recherche*. Enquiry; search: to examine; enquire.

It is not easy to *research* with due distinction, in the actions of eminent personages, both how much they may have been blemished by the envy of others, and what was corrupted by their own felicity.

*Wotton's Buckingham.*

By a skilful application of those notices, may be gained in such *researches* the accelerating and bettering of fruits, emptying mines, and draining fens.

*Glanville's Scopsis.*

I submit those mistakes, into which I may have fallen, to the better consideration of others, who shall have made *research* into this business with more felicity. *Holder.*

A felicity adapted to every rank, such as the *researches* of human wisdom sought for, but could not discover. *Rogers.*

**RESEAT**, *v. a.* Re and seat. To seat again.

When he's produced, will you *reseat* him  
Upon his father's throne? *Dryden.*

**RESEDA**, dyer's-weed, yellow-weed, weld, or wild woad; a genus of the order of trigynia, and dodecandria class of plants; natural order fifty-fourth, miscellaneous: *CAL.* monophyllous and partite: petals lancinated: *CAPS.* unilocular, and opening at the mouth. There are fourteen species, of which the most remarkable is the—

*R. luteola*, or common dyer's weld, growing naturally in waste places in many parts of Britain. The young leaves are often undulated; the stalk is a yard high, or more, terminated with a long naked spike of yellowish-green

flowers; the plant is cultivated and much used for dyeing silk and wool of a yellow color. It will grow with very little trouble, without dung, and on the very worst soils. It is therefore commonly sown with, or immediately after, barley or oats, without any additional care, except drawing a bush over it to harrow it in. The reaping of corn does it little or no hurt, as it grows but little the first year; and the next summer it is pulled and dried like flax. Much care and nicety, however, are requisite so as not to injure either the seed or stalk; or, which sometimes happens, damaging both, by letting it stand too long, or pulling it too green. To avoid these inconveniences a better method of culture has been devised. This new method is to plough and harrow the ground very fine, without dung, as equally as possible, and then sowing a gallon of seed upon an acre some time in August. In about two months it will be high enough to hoe, which must be carefully done, and the plants left about six inches asunder. In March it is to be hoed again, and this labor is to be repeated a third time in May. About the close of June, when the flower is in full vigor, and the stalk is become of a greenish-yellow, it should be pulled; a sufficient quantity of stems being left growing for seed till September. By these means the flower and stalk, both of them being carefully dried, will sell at a good price to the dyers, who employ it constantly, and in large quantities; add to this, that the seed being ripe, and in perfect order, will yield a very considerable profit. In a tolerable year, when the seasons have not been unfavorable, the advantages derived from this vegetable will answer very well; but if the summer should be remarkably fine, and proper care is taken in getting it in, there will be a very large produce upon an acre. The crop being, as has been shown, so early removed, the ground may be conveniently prepared for growing wheat the next year. Upon the whole it is in its nature a very valuable commodity in many respects, as it serves equally for woollen, linen, or silk; dyeing not only a rich deep yellow, but also, properly managed, all the different shades of yellow with brightness and beauty; and, if these be previously dipped blue, they are by the weld changed into a very pleasing green, which our artists can also diversify into a great variety of shades.

**RESEIZER**, *n. s.* One that seizes again.

**RESEIZURE**, *n. s.* Re and seizure. Repeated seizure; seizure a second time.

Here we have the charter of foundation; it is now the more easy to judge of the forfeiture of *remsuit*; deface the image, and you divest the right. *Bacon.*

**RESEND**, *v. a.* Re and send. To send back; to send again. Not in use.

I sent to her, by this same coxcomb,  
Tokens and letters, which she did *resend*.

*Shakspeare.*

**RESEMBLE**, *v. a.* } Fr. *resembler*. To compare  
**RESEMBLANCE**, *n. s.* } pare; exhibit or represent as like something else; be like: resemblance is, likeness; similitude.

These sensible things, which religion hath allowed, are *resemblances* formed according to things spiritual.

whereunto they serve as a hand to lead, and a way to direct. *Hooker.*

The torrid parts of Africk are resembled to a libbard's skin, the distance of whose spots represents the disperseness of habitations. *Brerewood.*

Most safely may we resemble ourselves to God, in respect of that pure faculty which is never separate from the love of God. *Raleigh.*

Fairest resemblance of thy Maker fair,  
Thee all things living gaze on. *Milton.*

One main end of poetry and painting is to please; they bear a great resemblance to each other. *Dryden's Dufresnoy.*

The quality produced hath commonly no resemblance with the thing producing it; wherefore we look on it as a bare effect of power. *Locke.*

They are but weak resemblances of our intentions, faint and imperfect copies, that may acquaint us with the general design, but can never express the life of the original. *Addison.*

I cannot help remarking the resemblance betwixt him and our author in qualities, fame, and fortune. *Pope.*

So chymists boast they have a power,  
From the dead ashes of a flower,  
Some faint resemblance to produce,  
But not the virtue. *Swift's Miscellanies.*

But deep this truth impressed my mind—  
Through all his works abroad,  
The heart, benevolent and kind,  
The most resembles God. *Burns.*

My dog! what remedy remains,  
Since, teach you all I can,  
I see you, after all my pains,  
So much resemble Man? *Couper.*

RESEN, a town of Assyria on the Tigris, mentioned by Moses as having been built by Nimrod; thought to be the Larissa of Xenophon. It is probable that the Greeks asking of what city those were the ruins of which they saw, the Assyrians might answer Laresen, Of Resen; which word Xenophon expressed by Larissa, a more familiar sound to a Greek ear.

RESENIUS (Peter John), a learned Danish counsellor and professor, born at Copenhagen in 1623. He studied four years at Leyden, was made counsellor of the German nation at Padua, and syndic of the university. On his return to Denmark he was made president of Copenhagen, counsellor justice, and counsellor of state, and ennobled. He wrote several works, the chief of which is his Edda Islandorum. He died in 1588.

RESENT, *v. a.* } *Fr. resentir.* To take  
RESENT'ER, *n. s.* } well or ill; to take ill is  
RESENT'FUL, *adj.* } the common usage: a  
RESENT'FULLY, *adv.* } resenter is one who  
RESENT'INGLY, } deeply feels an injury;  
RESENT'MENT, *n. s.* } resentful, malignant;  
soon provoked to anger, and long retaining it: the adverb corresponding: resentingly means with deep sense or impression; with malignity: resentment, strong perception of good or ill; deep feeling of anger.

A serious consideration of the mineral treasures of his territories, and the practical discoveries of them by way of my philosophical theory, he then so well resented, that afterwards, upon a mature digestion of my whole design, he commanded me to let your lordships understand how great an inclination he hath to further so hopeful a work. *Bacon.*

The earl was the worst philosopher, being a great resenter, and a weak dissembler of the least disgrace. *Wotton.*

Thou with scorn  
And anger would'st resent the offered wrong. *Milton.*

What he hath of sensible evidence, the very grand work of his demonstration is but the knowledge of his own resentment; but how the same things appear to others, they only know that are conscious to them; and how they are in themselves, only he that made them. *Glanville's Scepis.*

To be absent from any part of publick worship he thus deeply resented. *Fell.*

Hylobares judiciously and resentingly recapitulates your main reasonings. *More's Divine Dialogues.*

He retains vivid resentments of the more solid morality. *More.*

Can heavenly minds such high resentment show,  
Or exercise their spite in human woe? *Dryden.*

Such proceedings have been always resented, and often punished in this kingdom. *Davenant.*

I cannot, without some envy, and a just resentment against the opposite conduct of others, reflect upon that generosity wherewith the heads of a struggling faction treat those who will undertake to hold a pen in their defence. *Swift.*

Though it is hard to judge of the hearts of people, yet, where they declare their resentment and uneasiness at any thing, there they pass their judgment upon themselves. *Law.*

RESERVE', *v. a. & n. s.* } *Fr. reserver;*  
RESERVA'TION, *n. s.* } *Lat. reservo.* To  
RESERV'ATORY, } keep; save; re-  
RESERVED', *adj.* } tain; lay up in  
RESERV'EDLY, *adv.* } store: reservation  
RESERV'EDNESS, *n. s.* } is, the act of so do-  
RESERVOIR'. } ing; custody; state  
of being treasured up, or the thing treasured; place in which any thing is reserved: the adjective, adverb, and noun substantive corresponding: reservoir (from old *Fr. reservoir*) is a synonyme of reservatory.

David houghed all the chariot horses, but reserved of them for an hundred chariots. *2 Samuel.*

Will he reserve his anger for ever? will he keep it to the end? *Jeremiah.*

I could add many probabilities of the names of places; but they should be too long for this, and I reserve them for another. *Spenser.*

Reserve thy state, with better judgment check  
This hideous rashness. *Shakespeare.*

Ourself by monthly course,  
With reservation of an hundred knights,  
By you to be sustained, shall our abode  
Make with you by due turns. *Id.*

He willed me,  
In heedful'st reservation, to bestow them  
As notes, whose faculties inclusive were  
More than they of note. *Id.*

Observe their gravity  
And their reservedness, their many cautions  
Fitting their persons. *Ben Jonson's Catiline.*  
By formality, I mean something more than ceremony and compliment, even a solemn reservedness, which may well consist with honesty. *Wotton.*

Nor had I any reservations in my own soul when I passed that bill, nor repentings after. *King Charles.*

The breach seems like the scissures of an earthquake, and threatens to swallow all that attempt: to close it and reserves its cure only for omnipotence. *Decay of Piety.*

We swear with Jesuitical equivocations and mental reservations. *Sanderson against the Covenant.*

There was great wariness and reservedness, and so great a jealousy of each other that they had no mind to give or receive visits. *Clarendon.*

Flowers

Reserved from night, and kept for thee in store.

*Milton.*

This is academical reservation in matters of easy truth, or rather sceptical infidelity against the evidence of reason. *Browne.*

The virgins, besides the oil in their lamps, carried likewise a reserve in some other vessel for a continual supply. *Tillotson.*

Nothing reserved or sullen was to see,

But sweet regards.

*Dryden.*

The assent may be withheld upon this suggestion, that I know not yet all that may be said: and therefore, though I be beaten, it is not necessary I should yield, not knowing what forces there are in reserve behind. *Locke.*

To all obliging, yet reserved to all, None could himself the favour'd lover call. *Walsh.*

Dissimulation can but just guard a man within the compass of his own personal concerns, which yet may be more effectually done by that silence and reservedness that every man may innocently practise. *South's Sermons.*

However any one may concur in the general scheme, it is still with certain reserves and deviations, and with a salvo to his own private judgment.

*Addison's Freeholder.*

There is not a spring or fountain, but are well provided with huge cisterns and reservoirs of rain and snow-water. *Addison.*

Ere guardian thought cou'd bring its scattered aid, My soul surprized, and from herself disjointed, Left all reserve, and all the sex behind. *Prior.*

How I got such notice of that subterranean reservoir as to make a computation of the water now concealed therein, peruse the propositions concerning earthquakes. *Woodward.*

I must give only short hints, and write but obscurely and reservedly, until I have opportunity to express my sentiments with greater copiousness and perspicuity. *Id.*

Each has some darling lust, which pleads for a reserve, and which they would fain reconcile to the expectations of religion. *Rogers.*

He speaks reservedly, but he speaks with force; Nor can a word be changed but for a worse. *Pope.*

Who sees pale Mammon pine amidst his store, Sees but a backward steward for the poor;

This year a reservoir, to keep and spare; The next, a fountain spouting through his heir. *Id.*

Conceal your esteem and love in your own breast, and reserve your kind looks and language for private hours. *Swift.*

Fame is a bubble the reserved enjoy, Who strive to grasp it, as they touch, destroy.

*Young.*

RESERVE, or CORPS DE RESERVE, in military affairs, the third or last line of an army, drawn up for battle; so called because they are reserved to sustain the rest as occasion requires, and not to engage but in case of necessity.

A RESERVOIR is chiefly used for a place where water is collected and reserved, in order to be conveyed to distant places through pipes, or supply a fountain, or jet d'eau.

RESETTLE, *v. a.* Re and settle. To settle again.

Some roll their cask to mix it with the lees, and, after a resettlement, they rack it. *Merrimer.*

To the quieting of my passions, and the resettlement of my discomposed soul, I consider that grief is the most absurd of all the passions. *Norris.*

Will the house of Austria yield the least article, even of usurped prerogative, to resettle the minds of those princes in the alliance, who are alarmed at the consequences of the emperor's death? *Swift.*

RES'SIANT, *adj.* } Fr. *resseant*. Resident;  
RES'ANCE, *n. s.* } present in a place.

Solyman was come as far as Sophia, where the Turks' great lieutenant in Europe is always resident, before that the Hungarians were aware. *Knolles.*

The king forthwith banished all Flemings out of his kingdom, commanding his merchant adventurers, which had a residence in Antwerp, to return.

*Bacon's Henry VII.*

The Allobroges here resident in Rome.

*Ben Jonson.*

RESIDE', *v. n.* } Fr. *resider*; Lat. *resido*,  
RES'IDENCE, *n. s.* } *resideo*. To have abode;  
RES'IDENT, } live; dwell; also (from  
RES'IDENTIARY. } *resido*) to sink; subside:  
the derivatives follow both senses.

Within the infant rind of this small flower,  
Poison hath residence, and medicine power.

*Shakspeare. Romeo and Juliet.*

Separation is wrought by weight, as in the ordinary residence or settlement of liquors. *Bacon.*

How can God with such reside?

*Milton.*

Something holy lodges in that breast,

And with these raptures moves the vocal air,

To testify his hiduen residence. *Id.*

There was a great familiarity between the confessor and duke William; for the confessor had often made considerable residences in Normandy.

*Hale's Law of England.*

Our clearest waters, and such as seem simple unto sense, are much compounded unto reason, as may be observed in the evaporation of water, wherein, besides a terreous residence, some salt is also found.

*Browne's Vulgar Errors.*

Wasps and hornets will fly about, and use their wings, a good part of an hour after they have lost their heads; which is to be imputed to the residence of their soul in them still, and the intireness of the animal spirits not easily evaporating through their crustaceous bodies.

*More. The Immortality of the Soul, b. ii. ch. xi.*

Christ was the conductor of the Israelites into the land of Canaan, and their residentiary guardian.

*More.*

Oil of vitriol and petroleum, a drachm of each, turn into a mouldy substance; there residing in the bottom a fair cloud and a thick oil on the top.

*Boyle.*

In no fixed place the happy souls reside;  
In groves we live, and lie on mossy beds. *Dryden.*

I am not concerned in this objection, not thinking it necessary that Christ should be personally present or resident on earth in the millenium.

*Burnet's Theory of the Earth.*

Caprea had been the retirement of Augustus for some time, and the residence of Tiberius for several years. *Addison.*

The pope fears the English will suffer nothing like a resident or consul in his kingdoms. *Id.*

He is not said to be resident in a place who comes thither with a purpose of retiring immediately; so also he is said to be absent who is absent with his family. *Ayliffe's Parergon.*

RESIDUE, *n. s.* Fr. *residu*; Lat. *residuum*. The remaining part; that which is left.

'Tis enough to lose the legacy, or the *residuary* advantages of the estate left him by the deceased.

*Ayliffe.*

The causes are all such as expel the most volatile parts of the blood, and fix the *residue*.

*Arbutnot on Aliments.*

**RESIEGE'**, *v. a.* Fr. *re* and *siege*. To seat again. Obsolete.

In wretched prison long he did remain,  
Till they outreigned had their utmost date,

And then therein *resieged* was again,  
And ruled long with honourable state. *Spenser.*

**RESIGN'**, *v. a.* } Fr. *resigner*; Lat.  
**RESIGNATION**, *n. s.* } *resigno*. To give up  
**RESIGNMENT**, } a claim or possession;  
yield; submit; give up confidence: the noun substantives corresponding.

*Resign*

Your crown and kingdom indirectly held. *Shakespeare.*

I'll to the king, and signify to him  
That thus I have *resigned* to you my charge. *Id.*

Do that office of thine own good will;  
The *resignation* of thy state and crown. *Id.*

He intended to procure a *resignation* of the rights of the king's majesty's sisters and others, entitled to the possession of the crown. *Hayward.*

*Phœbus resigns* his darts, and Jove  
His thunder, to the god of love. *Denham.*

Desirous to *resign* and render back  
All I received. *Milton.*

What more reasonable than that we should in all things *resign up* ourselves to the will of God?

*Tillotson.*

Happy the man who studies nature's laws,  
His mind possessing in a quiet state,  
Fearless of fortune, and *resigned* to fate. *Dryden.*

Those, who always *resign* their judgment to the last man they heard or read, truth never sinks into those men's minds; but, *cameleon-like*, they take the color of what is laid before them, and as soon lose and *resign* it to the next that comes in their way. *Locke.*

There is a kind of sluggish *resignation*, as well as poorness and degeneracy of spirit, in a state of slavery, that very few will recover themselves out of it. *Addison.*

Ev'ry Ismena would *resign* her breast;  
And ev'ry dear Hippolytus be blest. *Prior.*

A firm, yet cautious, mind,  
Sincere, though prudent; constant, yet *resigned*. *Pope.*

Thou Power Supreme, whose mighty scheme  
These woes of mine fulfil,  
Here, firm, I rest, they must be best,  
Because they are Thy will.  
Then all I want (Oh! do thou grant  
This one request of mine!)

Since to enjoy thou dost deny,  
Assist me to *resign*. *Burns.*

And with one prayer to Mary Mother,  
And, it may be, a saint or two,  
As I *resigned* me to my fate,  
They led me to the castle gate. *Byron.*

**RESILIENCE**, *n. s.* } Lat. *resilio*. The  
**RESILIENCY**, *n. s.* } act of starting or leaping back.

If you strike a ball sidelong, the rebound will be as much the contrary way; whether there be any such *resilience* in echoes, that is, whether a man shall hear better if he stand aside the body re-percussing, than if he stand where he speaketh, may be tried. *Bacon's Natural History.*

**RES'IN**, *n. s.* } Fr. *resine*; Lat. *resina*.  
**RES'INOUS**, *adj.* } The fat sulphurous parts of vegetables: resinous, containing resin; consisting of resin.

Those vegetable substances that will dissolve in water are gums, those that will not dissolve and mix but with spirits or oil are *resins*. *Quincy.*

*Resinous* gums, dissolved in spirit of wine, are left fall again if the spirit be copiously diluted. *Boyle on Colours.*

**RESIN**, in natural history, a viscid juice oozing either spontaneously, or by incision, from several trees, as the pine, fir, &c. Resins are distinguished from gums by being inflammable, and soluble only in ardent spirits.

**RESIN**. The name resin is used to denote solid inflammable substances, of vegetable origin, soluble in alcohol, usually affording much soot by their combustion. They are likewise soluble in oils, but not at all in water; and are more or less acted upon by the alkalis.

All the resins appear to be simple volatile oils, rendered concrete by their combination with oxygen. The exposure of these to the open air, and the decomposition of acids applied to them, evidently lead to this conclusion.

There are some among the known resins which are very pure, and perfectly soluble in alcohol, such as the balsam of Mecca and of capivi, turpentine, elemi, &c.; others are less pure, and contain a small portion of extract, which renders them not totally soluble in alcohol; such are mastic, sandarach, guaiacum, labdanum, and dragon's blood.

What is most generally known by the name of resin simply, or sometimes of yellow rosin, is the residuum left after distilling the essential oil from turpentine. If this be urged by a stronger fire, a thick balsam, of a dark reddish color, called balsam of turpentine, comes over; and the residuum, which is rendered blackish, is called black resin, or colophony. See CHEMISTRY, Index.

Resins are employed for many purposes in the arts. The cheapest are used for torches, and to cover the outsides of ships and boats. The fine transparent resins compose varnishes. Some of them are employed medicinally, and enter into the composition of ointments and plasters; or internally, as the resins of scammony and jalap, which are purgative. Other resins, as benjamin and storax, are employed as perfumes.

They all become harder by exposure to a moderate heat; and it is upon this that the art of the japanner depends. If the surface to be japanned be covered with common tar only, and exposed to the temperature of 300° for a length of time, the coating becomes hard and infusible. At the same temperature, any other resin, applied in the same way, would assume a similar hardness.

**RESIST'**, *v. a. & n. s.* } Fr. *resister*; Lat.  
**RESIST'ANCE**, or  
**RESIST'ENCE**, *n. s.* } *resisto*. To oppose;  
**RESISTIBILITY**, *n. s.* } act against: make  
**RESIST'IBLE**, *adj.* } opposition: resist-  
**RESIST'LESS**. } ance, or resistance, is  
the quality or power of resisting: the adjective corresponding.



Submit to God, *resist* the devil, and he will flee.

*James ix.*

Demetrius, seeing that the land was quiet, and that no resistance was made against him, sent away all his forces.

*1 Mac.*

All the regions  
Do seemingly revolt; and, who *resist*,  
Are mocked for valiant ignorance,

And perish constant fools. *Shakespeare. Coriolanus.*  
Our own eyes do every where behold the sudden  
and *resistless* assaults of death.

*Raleigh.*

The *resistance* of bone to cold is greater than of  
flesh; for that the flesh shrinketh, but the bone *re-*  
*sisteth*, whereby the cold becometh more eager.

*Bacon.*

It is from corruption, and liberty to do evil, meet-  
ing with the *resistibility* of this sufficient grace, that  
one *resists* it.

*Hammond.*

To do ill our sole delight,

As being the contrary to his high will

Whom we *resist*.

*Milton.*

All at once to force *resistless* way.

*Id.*

That is irresistible; this, though potent, yet is in  
its own nature *resistible* by the will of man; though  
it many times prevails by its efficacy.

*Hale's Origin of Mankind.*

Whether the *resistibility* of Adam's reason did not  
equivalence the facility of Eve's seduction, we refer  
unto schoolmen.

*Browne.*

Music so softens and disarms the mind,

That not an arrow does *resistance* find.

*Waller.*

She changed her state;

*Resistless* in her love as in her hate.

*Dryden.*

The idea of solidity we receive by our touch, and  
it arises from the *resistance* which we find in body to  
the entrance of any other body into the place it pos-  
sesses.

*Locke.*

The name body, being the complex idea of exten-  
sion and *resistibility*, together, in the same subject,  
these two ideas are not exactly one and the same.

*Id.*

But that part of the *resistance* which arises from  
the vis inertæ is proportional to the density of the  
matter, and cannot be diminished by dividing the  
matter into smaller parts, nor by any other means  
than by decreasing the density of the medium.

*Newton's Optics.*

Though thine eyes *resistless* glances dart,

A stronger charm is thine, a generous heart.

Some forms, tho' bright, no mortal man can bear,  
Some none *resist*, though not exceeding fair.

*Young.*

RESOLVE', *v. a., v. n. & n. s.* Lat. *resolvo.*

RESOLVEDLY, *adv.* } To inform; free

RESOLVEDNESS, *n. s.* } from doubt

RESOLVENT, *n. s.* } or difficulty;

RESOLVER. } solve; clear;

*fix*; dissolve; melt; reduce: as a verb neuter, to  
determine; be settled or dissolved: resolve is  
fixed determination: the derivatives correspond  
with these senses.

In all things then are our consciences best *resolved*,  
and in most agreeable sort unto God and nature *re-*  
*solved*, when they are so far persuaded as those  
grounds of persuasion will bear.

*Hooker.*

Give me some breath,

Before I positively speak in this;

I will *resolve* your grace immediately.

*Shakespeare.*

Long since we were *resolved* of your truth,

Your faithful service, and your toil in war.

*Id.*

Have I not hideous death within my view!

Retaining but a quantity of life,

Which bleeds away, even as a form of wax

*Resolveth* from its figure 'gainst the fire?

*Id.*

I'm glad you thus continue your *resolve*,

To suck the sweets of sweet philosophy.

*Id.*

He always bent himself rather judiciously to *re-*  
*solve*, than by doubts to perplex a business.

*Hayward.*

I *resolve* the riddle of their loyalty, and give them  
opportunity to let the world see they mean not what  
they do, but what they say.

*King Charles.*

This *resolvedness*, this high fortitude in sin, can  
with no reason be imagined a preparative to its re-  
mission.

*Decay of Piety.*

Good or evil actions, commanded or prohibited by  
laws and precepts simply moral, may be *resolved* into  
some dictates and principles of the law of nature,  
imprinted on man's heart at the creation.

*White.*

Thy resolutions were not before sincere; conse-  
quently God, that saw that, cannot be thought to  
have justified that unsincere *resolver*, that dead faith.

*Hammond.*

When he sees

Himself by dogs, and dogs by men pursued,

He strait revokes his bold *resolves*, and more

Repents his courage, than his fear before.

*Denham.*

Good proof

This day affords, declaring thee *resolved*

To undergo with me one guilt.

*Milton.*

The effect is wonderful in all, and the causes best  
*resolvable* from observations made in the countries  
themselves, the parts through which they pass.

*Browne's Vulgar Errors.*

Into what can we *resolve* this strong inclination of  
mankind to this error? it is altogether unimaginable  
but that the reason of so universal a consent should  
be constant.

*Tillotson.*

Three is not precisely the number of the distinct  
elements whereinto mixt bodies are *resolvable* by fire.

*Boyle.*

*Resolve* me, strangers, whence and what you are?

*Dryden.*

I run to meet the alarms,

*Resolved* on death, *resolved* to die in arms.

*Id.*

Ye immortal souls, who once were men,

And now *resolved* to elements again.

*Id.*

Let men *resolve* of that as they please: this every  
intelligent being must grant, that there is something  
that is in himself that he would have happy.

*Locke.*

A man may be *resolvedly* patient unto death; so  
that it is not the mediocrity of resolution which  
makes the virtue; nor the extremity which makes the  
vice.

*Grew.*

Pride is of such intimate connection with ingrati-  
tude, that the actions of ingratitude seem directly *re-*  
*solvable* into pride, as the principal reason of the same.

*South.*

Cæsar's approach hath summoned us together,

And Rome attends her fate from our *resolves*.

*Addison.*

Happiness, it was *resolved* by all, must be some  
one uniform end, proportioned to the capacities of  
human nature, attainable by every man, independent  
of fortune.

*Rogers.*

As the serum of the blood is *resolvable* by a small  
heat, a greater heat coagulates it, so as to turn it  
horny like parchment.

*Arbuthnot.*

*Resolving* is bringing a fluid, which is now con-  
creted, into the state of fluidity again.

*Id.*

When the blood stagnates in any part, it first co-  
agulates, then *resolves* and turns alkaline.

*Id.*

Lactescent plants, as lettuce and endive, contain  
wholesome juice, *resolvent* of the bile, anodyne and  
cooling.

*Id.*

No man condemn me who has never felt

A woman's power, or tried the force of love;

All tempers yield and soften in those fires,  
Our honours, interests, *resolved* down,  
Run in the gentle current of our joys. *Southern*.  
In the beginning of inflammation they require re-  
pellents; and, in the increase, somewhat of *resolvants*  
ought to be mixed. *Wiseman*.

The decreets turn upon this point, and *resolve* all  
into a monarchical power at Rome. *Baker*.

**RESOLUTE**, *adj.* } Fr. *resolu*. Firm;  
**RESOLUTELY**, *adv.* } determined; fixed;  
**RESOLUTENESS**, *n. s.* } constant: the adverb  
**RESOLUTION**. } and noun substantives

corresponding: resolution is also the act of clear-  
ing or analysing difficulties; dissolution.

The rest of the Helots, which were otherwise scatter-  
ed, bent thitherward with a new life of *resolution*;  
as if their captain had been a root, out of which their  
courage had sprung. *Sidney*.

Be bloody, bold, and *resolute*; laugh to scorn  
The power of man; for none of woman born  
Shall harm Macbeth. *Shakespeare*.

I' the' progress of this business,

Ere a determinate *resolution*.

The bishop did require a respite. *Id.*

O Lord, *resolutions* of future reforming do not al-  
ways satisfy thy justice, nor prevent thy vengeance  
for former miscarriages. *King Charles*.

In the hot springs of extreme cold countries, the  
first heats are unsufferable, which proceed out of the  
*resolution* of humidity congealed. *Digby*.

They, who governed the parliament, had the *reso-  
lution* to act those monstrous things. *Clarendon*.

What reinforcement we may gain from hope,  
If not what *resolution* from despair. *Milton*.

To the present impulses of sense, memory, and in-  
stinct, all the sagacities of brutes may be reduced;  
though witty men, by analytical *resolution*, have  
chymically extracted an artificial logick out of all  
their actions. *Hale*.

In matters of antiquity, if their originals escape  
due relation, they fall into great obscurities, and  
such as future ages seldom reduce into a *resolution*.  
*Browne*.

We *resolutely* must,

To the few virtues that we have, be just.

*Roscommon*.

All that my *resoluteness* to make use of my ears,  
not tongue, could do, was to make them acquiesce.

*Boyle*.

A man, who lives a virtuous life, despises the  
pleasures of sin; and, notwithstanding all the al-  
lurements of sense, persists *resolutely* in his course.  
*Tillotson*.

The unravelling and *resolution* of the difficulties  
that are met with in the execution of the design, are  
the end of an action. *Dryden*.

We spend our days in deliberating, and we end  
them without coming to any *resolution*. *L'Estrange*.

How much this is in every man's power, by  
making *resolutions* to himself, is easy to try. *Locke*.

The mode of the will, which answers to dubita-  
tion, may be called suspension; that which answers to  
invention, *resolution*; and that which, in the phan-  
tastick will, is obstinacy, is constancy in the intel-  
lectual. *Crew*.

Some of those facts he examines, some he *reso-  
lutely* denies; others he endeavours to extenuate,  
and the rest he distorts with unnatural turns.

*Swift*.

**RESOLUTION**, in medicine and surgery, the  
disappearing of any tumor without coming to  
suppuration, or forming an abscess.

**RESOLUTION BAY**, a bay on the west coast of

St. Christina, one of the Marquesas Islands, in  
the South Pacific, has sometimes been called the  
Port of Mendana. It was discovered by that  
Spanish circumnavigator in 1595; and, as well  
as the islands, received his name. It obtained  
the name of Resolution Bay, in consequence of  
captain Cook's anchoring there the 7th of April,  
1774, in his second voyage. The country is well  
inhabited. Along the top of the hill to the north,  
which seems steep, appear villages enclosed by  
palisadoes. The valleys in this bay are full of  
trees. Long. 139° 8' W., lat. 9° 55' S.

**RESONANCE**, *n. s.* Lat. *resono*. Sound;  
resound.

His volant touch

Fled and pursued transverse the *resonant* fugue.

*Milton*.

An famous musician informed me that there were  
some famous lutes that attained not their full season-  
ing and best *resonance*, till they were about fourscore  
years old. *Boste*.

**RESORT**, *v. n. & n. s.* Fr. *ressortir*; *Qu.*  
Lat. *sortior*, to decide by lot? To have re-  
course; appeal; hence go or repair to; fall back  
to: act of visiting; concourse; assembly.

A little lowly hermitage it was,  
Downe in a dale, hard by a forest's side,  
Far from *resort* of people that did pass

In travail to and froe. *Spenser*. *Fuerie Queene*.

Join with me to forbid him her *resort*. *Shakespeare*.

Some know the *resorts* and falls of business, that  
cannot sink into the main of it. *Bacon*.

In the very time of Moses' law, when God's spe-  
cial commandments were most of all required, some  
festival days were ordained, and duly observed among  
the Jews, by authority of the church and state, and  
the same was not superstitious; for our Saviour him-  
self *resorted* unto them. *White*.

The king thought it time to *resort* to other coun-  
sels, and to provide force to chastise them, who had  
so much despised all his gentler remedies.

*Clarendon*.

The sons of light

Hasted, *resorted* to the summons high. *Milton*.

The inheritance of the son never *resorted* to the  
mother or to any of her ancestors, but both were  
totally excluded from the succession. *Hale*.

In fortune's empire blindly thus we go,

We wander after pathless destiny,

Whose dark *resorts* since prudence cannot know,  
In vain it would provide for what shall be.

*Dryden*.

Hither the heroes and the nymphs *resort*. *Pope*.

The like places of *resort* are frequented by me  
out of place. *Swift*.

**RESOUND**, *v. a.* Fr. *resonner*; Lat. *resono*.  
To echo; sound back; return as sound, or cele-  
brate in sound; be echoed back.

The sweet singer of Israel with his psaltery loudly  
*resounded* the innumerable benefits of the Almighty  
Creator. *Peachment*.

With other echo late I taught your shades,

To answer and *resound* far other song. *Milton*.

The sound of hymns, wherewith thy throne

Incompassed, shall *resound* thee ever blest. *Id.*

What *resounds* in fable or romance of Uther's sons.

*Id.*

What is common fame, which sounds from all  
quarters of the world, and *resounds* back to them  
again, but generally a loud, rattling, impudent lye.

*South*.

And Albion' cliffs *resound* the rural lay. *Pope*

The man for wisdom's various arts renowned,  
Long exercised in woes, oh muse! *resound*. *Id.*

**RESOURCE**, *n. s.* Fr. *ressource*; Skinner derives it from Fr. *resoudre*, to spring up; Lat. *re* and *sors*. Thomson. Some new or unexpected means that offer; resort; expedient.

Pallas viewed  
His foes pursuing, and his friends pursued;  
Used threatenings, mixed with prayers, his last *re-  
source*;

With these to move their minds, with those to fire  
their force. *Dryden.*

**RESOW**, *v. a.* Re and sow. To sow anew.  
Over wet at sowing time breedeth much dearth,  
insomuch as they are forced to *resow* summer corn.

**RESPEAK**, *v. n.* Re and speak. To an-  
swer.

The great cannon to the clouds shall tell,  
And the king's rowse the heaven shall bruit again,  
*Respeaking* earthly thunder. *Shakspeare. Hamlet.*

<b>RESPECT</b> , <i>v. a. &amp; n. s.</i>	} French <i>respecter</i> ; Lat. <i>respectus</i> . To regard; have rela- tion to; look to- ward; regard with esteem or reve- rence: as a noun- substantive, atten- tion; regard; honor; consideration; relation; venerated character: respectable, venerable: re- specter, one who has partial respect or regard; respectful, attentive; ceremonious; manifesting a degree of reverence: the adverb and noun substantive corresponding: <i>respective</i> , particu- lar; relative; worthy of reverence; careful (the last two senses obsolete): and the adverb cor- responding.
<b>RESPECTABLE</b> , <i>adj.</i>	
<b>RESPECTER</b> , <i>n. s.</i>	
<b>RESPECTFUL</b> , <i>adj.</i>	
<b>RESPECTFULLY</b> , <i>adv.</i>	
<b>RESPECTFULNESS</b> , <i>n. s.</i>	
<b>RESPECTIVE</b> , <i>adj.</i>	

**RESPECTIVELY**, *adv.*

The Lord had *respect* unto Abel and his offering.  
*Genesis.*

It is not good to have *respect* of persons in judg-  
ment. *Proverbs.*

There is nothing more terrible to a guilty heart  
than the eye of a *respected* friend. *Sidney.*

Whatsoever secret *respects* were likely to move  
them, for contenting of their minds, Calvin returned.  
*Hooker.*

*Respective* and wary men had rather seek quietly  
their own, and wish that the worst may go well, so  
it be not long of them, than with pain and hazard  
make themselves advisers for the common good.  
*Id.*

Among the ministers themselves, one being so far  
in estimation above the rest, the voices of the rest  
were likely to be given for the most part *respectively*  
with a kind of secret depen ency. *Id.*

Claudio, I quake,  
Lest thou should'st seven winters more *respect*  
Than a perpetual honour. *Shakspeare.*

You have too much *respect* upon the world;  
They lose it that do buy it with much care. *Id.*

Many of the best *respect* in Rome,  
Groaning under this age's yoke,  
Have wished that noble Brutus had his eyes. *Id.*

Since that *respects* of fortune are his love,  
shall not be his wife. *Id. King Lear.*

What should it be, that he *respects* in her,  
But I can make *respective* in myself? *Shakspeare.*  
Honest Flaminius, you are very *respectively* wel-  
come. *Id.*

If there had been no other choice, but that Adam  
had been left to the universal, Moses would not then

have said, eastward in Eden, seeing the world hath  
not East nor West, but *respectively*. *Raleigh.*

He was exceedingly *respective* and precise. *Id.*  
In orchards and gardens we do not so much *re-  
spect* beauty, as variety of ground for fruits, trees,  
and herbs. *Bacon.*

You must use them with fit *respects*, according to  
the bonds of nature; but you are of kin to their  
persons, not errors. *Id.*

The impressions from the objects of the senses do  
mingle *respectively* every one with his kind.

*Bacon's Natural History.*  
The blest gods do not love  
Ungodly actions; but *respect* the right,  
And in the works of pious men delight. *Chapman.*

The duke's carriage was to the gentlemen of fair  
*respect*, and bountiful to the soldier, according to any  
special value which he spied in any.

*Wotton's Buckingham.*  
There have been always monsters amongst them, in  
*respect* of their bodies. *Wilkins.*

Palladius adviseth, the front of his house should  
so *respect* the South, that in the first angle it receive  
the rising rays of the winter sun, and decline a little  
from the winter setting thereof. *Brownie.*

I have represented to you the excellency of the  
Christian religion, in *respect* of its clear discoveries  
of the nature of God, and in *respect* of the perfection  
of its laws. *Tillotson.*

In judgment-seats, not men's qualities, but causes  
only ought to be *respected*. *Kettleworth.*

To your glad genius sacrifice this day,  
Let common meats *respectfully* give way. *Dryden.*

*Aeneas* must be drawn a suppliant to Dido, with  
*respect* in his gestures, and humility in his eyes.

*Id. Dufresnoy.*  
He that will have his son have a *respect* for him,  
must have a great reverence for his son. *Locke.*

Whoever tastes, let him with grateful heart  
*Respect* that ancient loyal house. *Philips.*

The same men treat the Lord's Day with as little  
*respect*, and make the advantage of rest and leisure  
from their worldly affairs only an instrument to pro-  
mote their pleasure and diversions. *Nelson.*

Good and evil are in morality, as the East and  
West are in the frame of the world, founded in and  
divided by that fixed and unalterable situation which  
they have *respectively* in the whole body of the uni-  
verse. *South's Sermons.*

The principles of those governments are *respectively*  
disclaimed and abhorred by all men of sense and  
virtue in both parties. *Addison.*

I found the king abandoned to neglect;  
Seen without awe, and served without *respect*.  
*Prior.*

Will you be only, and for ever mine?  
From this dear bosom shall I ne'er be torn?  
Or you grow cold, *respectful*, or forsorn? *Id.*

The medium intended is not an absolute, but a  
*respective* medium; the proportion recommended to  
all is the same: but the things to be desired in this  
proportion vary. *Rogers.*

I always loved and *respected* Sir William. *Swift.*  
Neither is any condition more honourable in the  
sight of God than another; otherwise he would be a  
*respector* of persons; for he hath proposed the same  
salvation to all. *Id.*

**RESPIRE**, *v. n.* Fr. *respirer*; Lat. *respiro*.  
To breathe; catch breath: hence to pause;  
rest.

Till breathless both themselves aside retire,  
Where foaming wrath, their cruel turks they whet,  
And trample the' earth the wiles they may *respi-*  
*Spenser*

Apollonius of Tyana affirmed that the ebbing and flowing of the sea was the *respiration* of the world, drawing in water as breath, and putting it forth again. *Bacon.*

Syrups or other expectoratives do not advantage in coughs, by slipping down between the epiglottis; for, as I instanced before, that must necessarily occasion a greater cough and difficulty of *respiration*. *Harveu on Consumptions.*

I, a prisoner chained, scarce freely draw  
The air imprisoned also, close and damp,  
Unwholesome draught; but here I feel amends,  
The breath of heaven fresh blowing, pure, and sweet,  
With day-spring born; here leave me to *respire*. *Milton.*

Till the day

Appear of *respiration* to the just,  
And vengeance to the wicked. *Id.*

The ladies gasped, and scarcely could *respire*;  
The breath they drew no longer air but fire. *Dryden.*

The author of nature foreknew the necessity of rains and dews to the present structure of plants, and the uses of *respiration* to animals; and therefore created those correspondent properties in the atmosphere. *Bentley's Sermons.*

Hark! he strikes the golden lyre;  
And see! the tortured ghosts *respire*,  
See shady forms advance. *Pope's St. Cecilia.*

**RESPIRATION.** See ANATOMY and PHYSIOLOGY.—Though the muscles of *respiration*, having a mixed motion, are in some measure dependent on the will, yet no human being, after having once respired, can live many moments without it. In an attempt to hold one's breath, the blood soon begins to distend the veins, which cannot empty their contents into the heart, and we are able only during a very little time to resist the stimulus to inspiration. In drowning, the circulation seems to be stopped upon this principle; and, in hanging, the pressure made on the jugular veins co-operates with the stoppage of *respiration* in bringing on death. Amphibious animals *respire* by means of lungs; but they can suspend their motion even whilst they are in the air; as has been observed with regard to frogs, which stop their *respiration* at pleasure. See **PHYSIOLOGY.**

**RES'PITE**, *n. s.* & *v. a.* Fr. *respit*. Reprieve; suspension of a capital sentence; pause: to suspend; delay; relieve by delay.

The fox then counselled the ape for to require  
*Respite* till morrow to answer his desire. *Spenser.*

This customary war, which troubleth all the world,  
giveth little *respite* or breathing time of peace, doth usually borrow pretence from the necessity, to make itself appear more honest. *Raleigh.*

Some pause and *respite* only I require,  
Till with my tears I shall have quenched my fire. *Denham.*

An act passed for the satisfaction of the officers of the king's army, by which they were promised payment in November following; till which time they were to *respite* it, and be contented that the common soldiers and inferior officers should be satisfied upon their disbanding. *Clarendon.*

I had a hope to spend  
Quiet, though sad, the *respite* of that day,  
That must be mortal to us both. *Milton.*

In what bower or shade  
Though find'st him, from the heat of noon retired,  
To *respite* his day-labour with repast,  
Or with repose. *Id. Paradise Lost.*

Wisdom and eloquence in vain would plead  
One moment's *respite* for the learned head;  
Judges of writings and of men have died. *Prior.*

**RESPLENDENT**, *adj.* } Latin *resplendens*.  
**RESPLENDENTLY**, *adv.* } Bright; shining;  
**RESPLENDENCY**, *n. s.* } lustrous: the noun  
substantive corresponding.

There all within full rich arrayed he found,  
With royal arras and *resplendent* gold. *Spenser.*  
The ancient electrum had in it a fifth of silver to the gold, and made a compound metal, as fit for most uses as gold, and more *resplendent*. *Bacon.*  
Rich in commodities, beautiful in situation, *resplendent* in all glory. *Camden's Remains.*

Son! thou in whom my glory I behold  
In full *resplendence*, heir of all my might. *Milton.*

Empress of this fair world, *resplendent* Eve! *Id.*  
To neglect that supreme *resplendency* that shines in God, for those dim representations of it in the creature, is as absurd as it were for a Persian to offer his sacrifice to a parhelion instead of adoring. *Boyle.*

Every body looks most splendid and luminous in the light of its own colour; cinnaber in the homogeneous light is most *resplendent*, in the green light it is manifestly less *resplendent*, in the blue light still less. *Newton's Opticks.*

*Resplendent* brass and more *resplendent* dames. *Pope.*

**RESPOND'**, *v. v.* } French *respondre*;  
**RESPON'DENT**, *n. s.* } Lat. *respondeo*. To  
**RESPONSE'**, } answer; correspond:  
**RESPON'SIBLE**, *adj.* } a respondent is he  
**RESPON'SIBLENESS**, *n. s.* } who formally or legally  
**RESPON'SION**, } answers in a  
**RESPON'SIVE**, *adj.* } recitation dispute or  
**RESPON'SORY**. } suit: response, the  
answer made: responsible is, answerable; accountable; capable of giving answer or satisfaction; pecuniarily competent: the noun-substantive corresponding: response, the act of answering (not used): responsive, making answer; corresponding: responsory, containing answer.

The oracles, which had before flourished, began to droop, and, from giving *responses* in verse, descended to prose, and within a while were utterly silenced. *Hammond.*

Heathens, who have certainly the talent of natural knowledge, are *responsible* for it. *Id.*

How becomingly does Philopolis exercise his office, and seasonably commit the opponent with the *respondent*, like a long practised moderator? *More.*

The necessity of a proportion of money to trade depends on money as a pledge, which writing cannot supply the place of; since the bill I receive from one man will not be accepted as security by another, he not knowing that the bill is legal, or that the man bound is honest or *responsible*. *Locke.*

In giving an answer, the *respondent* should be in court, and personally admonished by the judge to answer the judge's interrogation. *Ayliffe's Parergon.*

A certificate is a *responsive* letter, or letter by way of answer. *Id.*

Mere natural piety has taught men to receive the *responses* of the gods with all possible veneration. *Government of the Tongue.*

He as much satisfies the itch of telling news; he as much persuades his hearers; and all this while he has his retreat secure, and stands not *responsible* for the truth of his relations. *Id.*

To make his parishioners kneel and join in the  
prayers, he gave every one of them a hassock and  
common prayer book. *Addison.*

Sing of love and gay desire,  
*Responsive* to the warbling lyre. *Fenton.*

Be there Demodocus the bard of fame,  
Taught by the gods to please, when high he sings  
The vocal lay *responsive* to the strings. *Pope.*

To every theme *responds* thy various lay ;  
Here rolls a torrent, there meanders play.

Let the *respondent* not turn opponent ; except in  
retorting the argument upon his adversary after a direct  
*response* ; and even this is allowed only as a confirmation  
of his own *response*. *Watts.*

RESSIUS (Rutger), a learned professor of  
Greek at Louvain, of the sixteenth century.  
Erasmus gives him a high character. He published  
many works, particularly a correct edition of the  
Aphorisms of Hippocrates. He died in 1545.

REST, *n. s., adj., v. a., &* Sax. *reƿt*; Dan.  
RESTFUL, *adj.* [*v. n.*] *rust*; Belg. *rust*.  
RESTLESS, *adj.* } Quiet ; stillness ;  
RESTLESSLY, *adv.* } repose ; sleep ; ces-  
sation from toil ; that on which any thing rests ;  
remainder ; place of repose ; hope : as an ad-  
jective, others ; those not previously includ-  
ed : as a verb neuter, to be quiet, or in slumber ;  
be acquiescent ; lean ; sleep ; be asleep ; cease  
from labor ; die ; be left or remain : as a verb ac-  
tive, to lay to rest ; place as a support : the ad-  
jectives and adverb following correspond with the  
common senses of rest.

Six days shalt thou do thy work, and on the se-  
venth day thou shalt rest. *Exodus xxiii. 12.*

The ark went before to search out a resting place  
for them. *Numbers x. 33.*

There the weary be at rest. *Job ili. 17.*  
He will not rest content, though thou givest many  
gifts. *Proverbs.*

Learn of me, for I am meek and lowly in heart ;  
and you shall find rest unto your souls. *Matthew.*

Is not my arm of length,  
That reacheth from the restful English court,  
As far as Calais to my uncle's head ? *Shakspeare.*

Putrefaction asketh rest ; for the subtle motion,  
which putrefaction requirerh, is disturbed by any  
agitation. *Bacon.*

A man may think, that a musket may be shot off  
as well upon the arm, as upon a rest ; but when all  
is done, good counsel setteth business straight. *Id.*

There resteth the comparative ; that is, its being  
granted, that it is either lawful or binding, yet whether  
other things be not preferred before it, as extirpa-  
tion of heresies. *Id.*

Forth pricked Clorinda from the throng,  
And 'gainst Tancredie set her spear in rest. *Fairfax.*

He was stout of courage, strong of hand,  
Bold was his heart, and restless was his spright. *Id.*

Let him keep the rest,  
But keep them with repining *restlessness* !  
Let him be rich and weary, that at least,  
If goodness lead him not, yet weariness  
May toss him to my breast. *Herbert.*

The root cut off, from whence these tumults rose,  
He should have rest, the commonwealth repose. *Daniel.*

*Restlessness* and intermission from sleep, grieved  
persons are molested with, whereby the blood is  
dried. *Huxley.*

Where can a frail man hide him ? in what arms  
Shall a short life enjoy a little rest ? *Fanshawe.*

When you enter into the regions of death, you  
rest from all your labours and your fears. *Taylor.*

Could we not wake from that lethargick dream,  
But to be restless in a worse extreme ? *Denham.*

This answer would render their counsels of less  
reverence to the people, if upon those reasons, they  
should recede from what they had, with that confidence  
and disdain of the house of peers, demanded of the  
king ; they therefore resolved to set up their rest upon  
that stake, and to go through it, or perish in the at-  
tempt. *Clarendon.*

What cause moved the Creator, in his holy rest,  
So late to build ? *Milton.*

Sustained by him with comforts, till we end  
In dust, our final rest and native home. *Id.*

All things retired to rest.  
Mind us of like repose, *Id.*

Over the tent a cloud shall rest by day. *Id.*  
From work

Resting, he blessed the seventh day. *Id.*  
Fal'n he is ; and now

What rests, but that the mortal sentence pass  
On his transgression ? *Id. Paradise Lost.*

Ease to the body some, none to the mind  
From restless thoughts, that like a deadly swarm  
Of hornets armed, no sooner found alone,  
But rush upon me thronging, and present  
Times past, what once I was, and what I'm now. *Milton.*

The trembling *restlessness* of the needle, in any  
but the north point of the compass, manifests its in-  
clination to the pole ; which its wavering and its rest  
bear equal witness to. *Boyle.*

As the vexed world, to find repose, at last,  
Itself into Augustus' arms did cast ;  
So England now doth, with like toil oppress.  
Her weary head upon your bosom rest. *Waller.*

Religion gives part of its reward in hand, the pre-  
sent comfort of having done our duty ; and, for the  
rest, it offers us the best security that heaven can  
give. *Tillotson.*

Plato, and the rest of the philosophers, acknow-  
ledged the unity, power, wisdom, goodness, and pro-  
vidence of the supreme God. *Stillingfleet.*

Oft with holy hymns he charmed their ears ;  
For David left him, when he went to rest,  
His lyre. *Dryden's Persius.*

With what a load of vengeance am I prest,  
Yet never, never, can I hope for rest ;  
For when my heavy burden I remove,  
The weight falls down, and crushes her I love. *Dryden.*

Their vizors closed, their lances in the rest  
Or at the helmet pointed, or the crest ;  
They speed the race. *Id. Knight's Tale.*

The power in glory shone,  
By her bent bow and her keen arrows known,  
The rest a huntress. *Id.*

Armed like the rest, the Trojan prince appears.  
And by his pious labour urges theirs. *Druden.*

There yet survives the lawful heir  
Of Sancho's blood, whom, when I shall produce,  
I rest assured to see you pale with fear. *Id.*

On him I rested,  
And, not without consid'ring, fixed my fate. *Id.*  
He's proud, fantastic, apt to change,  
*Restless* at home, and ever prone to range. *Id.*

Every creature has a share in the common bless-  
ings of providence ; and every creature should rest  
well satisfied with its proportion in them. *L'Esrange.*

All things past are equally and perfectly at rest ;  
and to this way of consideration of them are all

one, whether they were before the world, or but yesterday.

Sometimes it *rests* upon testimony, when testimony of right has nothing to do; because it is easier to believe, than to be scientifically instructed. *Id.*

Take the handle in your right hand, and, clasping the blade of it in your left, lean it steady upon the *rest*, holding the edge a little aslant over the work, so as a corner of the thin side of the chissel may bear upon the *rest*, and the flat side of the chissel may make a small angle with the *rest*. *Maxon.*

The Christian chuseth for his day of *rest* the first day of the week, that he might thereby profess himself a servant of God, who on the morning of that day vanquished Satan. *Nelson.*

Like the sun, it had light and agility; it knew no *rest* but in motion, no quiet but in activity.

To urge the foe to battle; Prompted by blind revenge and wild despair, Were to refuse th' awards of providence, And not to *rest* in heaven's determination. *Addison.*

What tongue can speak the *restless* monarch's woes,

When God and Nathan were declared his foes?

Upon so equal terms did they all stand, that no one had a fairer pretence of right than the *rest*.

We find our souls disordered and *restless*, tossed and disquieted by passions, ever seeking happiness in the enjoyments of this world, and ever missing what they seek.

The protestants, having well studied the fathers, were now willing to *rest* their cause, not upon scripture only, but fathers too; so far at least as the three first centuries.

My tost limbs are wearied into *rest*. I sought my bed, in hopes relief to find, But *restlessness* was mistress of my mind.

Here *rests* his head upon the lap of earth, A youth to fortune and to fame unknown.

But hawks will rob the tender joys That bless the lintwhite's nest;

And frost will blight the fairest flowers, And love will break the soundest *rest*.

**REST**, in military affairs, an instrument in the shape of a fork, formerly used to support the old heavy musket, when the men were ordered to present and fire. Sometimes these rests were armed with a weapon called a swine's feather, which was a sort of sword blade that issued from the staff of the rest, at the head; this being placed before the musketeers when loading, served, like the stakes placed before the archers and the lancers, to keep off the cavalry. Rests were of different lengths, according to the heights of the men who were to use them; and, when the musket was shouldered on the march, were carried in the right hand, or hung upon it, by means of a loop.

**RESTAG'NATE**, *v. n.* } Re and stagnate.  
**RESTAG'NANT**, *adj.* } To stand without flow: remaining without flow or motion.

Upon the tops of high mountains, the air, which bears against the *restagnant* quicksilver, is less pressed by the less ponderous incumbent air.

The blood returns thick, and is apt to *restagnate*.

**RESTAURATION**, *n. s.* Lat. *restauro*. The act of recovering to the former state.

Adam is in us an original cause of our nature,

and of that corruption of nature which causeth death, Christ as the cause original of *restauration* to life.

O my dear father! *restauration* hang Thy medicine on my lips; and let this kiss Repair those violent harms, that my two sisters Have in thy reverence made.

Spermatical parts will not admit a regeneration, much less will they receive an integral *restauration*.

**RESTEM'**, *v. a.* Re and stem. To force back against the current.

How they *restem* Their backward course, bearing with frank appearance

Towards Cyprus.

**RESTIFF**, *adj.* } Fr. *restef*; Ital. *restivo*.  
**RES'TIVENESS**, *n. s.* } Or from **REST**. Unwilling  
**RES'TY**, *adj.* } to stir; resolute against

going forward; stubborn; being at *rest*: the noun substantive corresponding; and *resty* being a synonyme of *restiff*.

Come, our stomachs Will make what's homely savoury, weariness Can snore upon the flint, when *resty* sloth

Finds the down pillow hard.

Overt virtues bring forth praise; but secret virtues bring forth fortune; certain deliveries of a man's self, which the Spanish name *disemboltura* partly expresseth, where there be not stands nor *restiveness* in a man's nature; but the wheels of his mind keep way with the wheels of his fortune.

That it gave occasion to some men's further *restiveness* is imputable to their own depraved tempers.

Palsies oftenest happen upon the left side; the most vigorous part protecting itself, and protruding the matter upon the weaker and *restive* side.

All, who before him did ascend the throne, Labour'd to draw three *restive* nations on.

Some, with studious care, Their *restiff* steeds in sandy plains prepare.

This *restiff* stubbornness is never to be excused under any pretence whatsoever.

Have not other hands been tried and found *resty*? but we stick at nothing.

Men of discretion, whom people in power may with little ceremony load as heavy as they please, find them neither *resty* nor vicious.

Every great genius seems to ride upon mankind, like Pyrrhus on his elephant; and the way to have the absolute ascendant of your *resty* nag, and to keep your seat, is, at your first mounting, to afford him the whip and spurs plentifully; after which you may travel the rest of the day with great alacrity. Once kick the world, and the world and you live together at a reasonable good understanding.

**RESTIO**, in botany, a genus of the triandria order, and diœcia class of plants: MALE CAL. an ovate spike of membranaceous scales: COR. proper, hexapetalous, and persistent: FEMALE CAL. and cor. as in the male; the germ roundish, and sex-fulcated; styles, three erect and persistent: CAPS. roundish, with six plaits, and is rostrated and trilocular: SEEDS oblong and cylindrical. Twenty-eight species, all natives of the Cape, several resembling rushes, and used in making ropes, &c.

**RESTITUTION**, *n. s.* Lat. *restitutio*. The act of restoring what is lost or taken away; or of restoring a former state.

He *restitution* to the value makes;  
Nor joy in his extorted treasure takes. *Sandys*.  
To subdue an usurper should be no unjust enter-  
prise or wrongful war, but a *restitution* of ancient  
rights unto the crown of England, from whence they  
were most unjustly expelled and long kept out.

*Spenser on Ireland.*

He would pawn his fortunes  
To hopeless *restitution*, so he might  
Be called your vanquisher. *Shakspeare. Coriolanus*.  
Whosoever is an effective real cause of doing a  
neighbour wrong, by what instrument soever he does  
it, is bound to make *restitution*. *Taylor*.  
In case our offence against God hath been com-  
plicated with injury to men, it is but reasonable we  
should make *restitution*. *Tillotson*.  
In the woody parts of plants, which are their  
bones, the principles are so compounded as to make  
them flexible without joints, and also elastick; that  
so their roots may yield to stones, and their trunks  
to the wind, with a power of *restitution*. *Grew*.  
A great man, who has never been known willingly  
to pay a just debt, ought not all of a sudden to be  
introduced, making *restitution* of thousands he has  
cheated: let it suffice to pay twenty pounds to a  
friend who has lost his note. *Arbutnot*.

**RESTITUTED MEDALS, or COINS**, is a term  
used by antiquaries for such coins and medals  
as were struck by the emperors, to retrieve the  
memory of their predecessors. Hence, in several  
medals, we find the letters *REST*. This practice  
was first begun by Claudius, by his striking  
afresh several medals of Augustus. Nero did  
the same; and Titus struck restitutions of most  
of his predecessors. Gallienus struck a general  
*restitution* of all the preceding emperors on two  
medals; the one bearing an altar, the other an  
eagle, without the rest.

**RESTITUTOR**, in numismatology, was a title  
very frequently applied to the emperors on coins,  
by the people to whom they restored any privi-  
leges, or on whom they conferred any political  
favours. In such cases, the emperor is commonly  
represented in the act of  
lifting up a figure sym-  
bolic of the country that  
has received the benefit,  
as in the annexed figure,  
where the female with  
the ears of corn in her  
hand is symbolical of  
Africa, who is raised up  
by the emperor Adrian.



**RESTORE**, *v. a.*  
**RESTORABLE**,  
**RESTORATION**, *n. s.*  
**RESTORATIVE**, *n. s. & adj.* } Fr. *restaurer* ;  
 } Ital. *restorare* ;  
 } Lat. *restauro*. To  
give or bring back  
what has been lost or taken away; retrieve;  
cure: the derivatives corresponding.

*Restore* the man his wife. *Genesis xx. 7.*  
He shall *restore* in the principal, and add the fifth  
part more. *Leuiticus vi. 5.*

I will kiss thy lips;  
Haply some poison yet doth hang upon them,  
To make me die with a *restorative*. *Shakspeare*.  
These artificial experiments are but so many  
essays, whereby men attempt to *restore* themselves  
from the first general curse inflicted upon their  
labours. *Wilkins's Mathematical Magick*.

Their tastes no knowledge works, at least of evil;  
But life preserves, destroys life's enemy,  
Hunger, with sweet *restorative* delight. *Milton*.

Loss of Eden, till one greater man  
*Restore* it, and regain the blissful seat. *Id.*  
Next to the Son

Destined *restorer* of mankind, by whom  
New heaven and earth shall to the ages rise. *Id.*  
Hail, royal Albion, hail to thee,  
Thy longing people's expectation!

Sent from the gods to set us free  
From bondage and from usurpation.  
Behold the different climes agree,  
Rejoicing in thy *restoration*. *Dryden's Albion*.

She lands him on his native shores,  
And to his father's longing arms *restores*. *Dryden*.  
I foretel you, as the *restorer* of poetry. *Id.*

Asses' milk is an excellent *restorative* in consump-  
tions. *Mortimer*.

God saw it necessary by such mortifications to  
quench the boundless rage of an insatiable intem-  
perance, to make the weakness of the flesh the phys-  
ick and *restorative* of the spirit. *South's Sermons*.

In his *Odyssey*, Homer explains, that the hardest  
difficulties may be overcome by labour, and our for-  
tune *restored* after the severest afflictions. *Prior*.

The change is great in this *restoration* of the man,  
from a state of spiritual darkness to a capacity of  
perceiving divine truth. *Rogers*.

He prescribes an English gallon of asses' milk,  
especially as a *restorative*. *Arbutnot*.  
Garth, faster than a plague destroys, *restores*.

*Graveille*.  
By cutting turf without any regularity great quan-  
tities of *restorable* land are made utterly desolate.

*Swift*.  
The Athenians, now deprived of the only person  
that was able to recover their losses, repent of their  
rashness, and endeavour in vain for his *restoration*.

*Id.*  
Here are ten thousand persons reduced to the ne-  
cessity of a low diet and moderate exercise, who are  
the only great *restorers* of our breed, without which  
the nation would in an age become one great hospi-  
tal. *Id.*

**RESTORATION**, a small island in the South  
Pacific, on the east coast of New Holland, dis-  
covered by captain Bligh in 1789. It is about  
a league in circuit; the trees are small, and the  
soil scanty. Oysters are plentiful, and it abounds  
in water.

**RESTORATION COVE**, a bay visited by Van-  
couver, on the north-west coast of North America,  
in Burke's Canal, not far from Fitzhugh's Sound.  
It was discovered on the 29th May, 1792, the  
anniversary of the Restoration. The breadth at  
the entrance, in a north and south direction, is  
about a mile and a quarter, and its depth from  
the centre of the entrance, in a north-east direc-  
tion, three-quarters of a mile. The soundings,  
though deep, are regular, from sixty fathoms at  
the entrance, to five and ten fathoms close to the  
shore. The land on the opposite side of the  
arm is about two miles and a half distant. Skins  
were here offered for sale of the animal whence  
the wool is procured of which the garments  
made by the inhabitants of North-west America  
are formed. They appeared too long to belong  
to any animal of the canine race; and were, ex-  
clusively of the head or tail, fifty inches long,  
and thirty-six inches broad, exclusively of the  
legs. The wool seemed to be afforded princi-

pally on the back, and towards the shoulders, where a kind of crest is formed by long bristly hairs, that protrude themselves through it; and the same sort of wool forms an outer covering to the whole animal, entirely hiding the fine wool, which is short, and of a very different description. All the skins seen by Vancouver were white, or rather of a cream color; the felt was thick, and appeared of a strong texture.

Vancouver was here visited by the inhabitants, in great numbers; and they appeared in general to be a friendly race of people, disposed for traffic, and honest. They discovered great vivacity in their manners. The women wore a hideous wooden appendage in an incision of the underlip.

**RESTORATIVE**, in medicine, is a remedy proper for restoring and retrieving the strength and vigor both of the body and animal spirits. All under this class, says Quincy, are rather nutrimental than medicinal; and are more administered to repair the wastes of the constitution than to alter and rectify its disorders.

**RESTRAIN'**, *v. a.* } *Fr. restreindre*; *Lat. restringo*. To withhold;  
**RESTRAIN'ABLE**, *adj.* }  
**RESTRAINED'LY**, *adv.* } keep or pull in; repress;  
**RESTRAIN'ER**, *n. s.* } hinder; abridge; limit;  
**RESTRAINT'**, } restrainable is, governable; capable of restraint: restrainedly, with restraint or latitude: restrainer, he who withholds or restrains: restraint, the act of withholding; repression; limitation; prohibition.

There is no *restraint* to the Lord to save, by many or by few. 1 Samuel xiv. 6.

We *restrain* it to those only duties, which all men, by force of natural wit, understand to be such duties as concern all men. Hooker.

If she *restrained* the riots of your followers,  
 'Tis to such wholesome end as clears her. Shakespeare.

Merciful powers!  
*Restrain* in me the cursed thoughts, that nature Gives way to in repose. Id. Macbeth.  
 His horse with a half checked bit, and a head stall of sheep's leather, which being *restrained* to keep him from stumbling, hath been often burst, and now repaired with knots. Shakespeare.

She will well excuse,  
 Why at this time the doors are barred against you. Depart in patience.  
 And about evening come yourself alone,  
 To know the reason of this strange *restraint*. Shakespeare.

That Christ's dying for all is the express doctrine of the scripture is manifested by the world, which is a word of the widest extent, and although it be sometimes used more *restrainedly*, yet never doth signify a far smaller disproportionable part of the world. Hammond.

What moved our parents to transgress his will  
 For one *restraint*, lords of the world besides? Milton.

Therein we must not deny a liberty; nor is the hand of the painter more *restrainable* than the pen of the poet. Browne.

If nothing can relieve us, we must with patience submit unto that *restraint*, and expect the will of the restrainer. Browne's Vulgar Errors.

If all were granted, yet it must be maintained within any bold *restraints*, far otherwise than it is received. Browne.

The law of nature would be in vain, if there were nobody that, in the state of nature, had a power to execute that law, and thereby preserve the innocent and *restrain* offenders. Locke.

It is to no purpose to lay *restraints* or give privileges to men, in such general terms, as the particular persons concerned cannot be known. Id.

Upon what ground can a man promise himself a future repentance, who cannot promise himself a futurity; whose life depends upon his breath, and is so *restrained* to the present that it cannot secure to itself the reversion of the very next minute. South.

I think it a manifest disadvantage, and a great *restraint* upon us. Felton on the Classics.

Not only a metaphysical or natural, but a moral universality also is to be *restrained* by a part of the predicate; as all the Italians are politicians; that is, those among the Italians, who are politicians, are subtle politicians; i. e. they are generally so. Watts's Logic.

**RESTRICT**, *v. a.* } *Lat. restrictus*. To  
**RESTRICT'ION**, *n. s.* } limit; confine: the  
**RESTRICT'IVE**, *adj.* } derivatives corre-  
**RESTRICT'IVELY**, *adv.* } sponding.

The two latter indicate phlebotomy for revulsion, *restringents* to stench, and *incrassatives* to thicken the blood. Harvey.

They who would make the *restrictive* particle belong to the latter clause, and not to the first, do not attend to the reason. Skillingsfleet.

Iron manufacture, of all others, ought the least to be encouraged in Ireland; or, if it be, it requires the most *restriction* to certain places. Temple.

This is to have the same *restrictions* with all other recreations, that it be made a divertimento, not a trade. Government of the Tongue.

All speech, tending to the glory of God or the good of man, is aright directed; which is not to be understood so *restrictively*, as if nothing but divinity, or necessary concerns of life, may lawfully be brought into discourse. Id.

Each other gift, which God on man bestows,  
 Its proper bounds and due *restriction* knows;  
 To one fixed purpose dedicates its power. Prior.

Celsus's rule, with the proper *restrictions*, is good for people in health. Arbuthnot.

I applied a plaster over it, made up with my common *restrictive* powder. Wiseman's Surgery.

I'll no say men are villains a';  
 The real hardened wicked,  
 Wha hae nae check but human law,  
 Are to a few *restricted*. Burns.

**RESUBLIME'**, *v. a.* Re and sublime. To sublime another time.

When mercury sublimate is *resublimed* with fresh mercury, it becomes mercurius dulcis, which is a white tasteless earth, scarce dissolvable in water, and mercurius dulcis *resublimed* with spirit of salt returns into mercury sublimate. Newton.

**RESULT'**, *v. a. & n. s.* } *Fr. resulter*; *Lat.*  
**RESULT'ANCE**, *n. s.* } *resulto*. To fly or  
 come back; follow as a consequence: resili-  
 ence; consequence; the act of resulting.

Rue prospers much, if set by a fig-tree; which is caused, not by reason of friendship, but by extraction of a contrary juice; the one drawing juice fit to *result* sweet the other bitter. Bacon's Natural History.

Sound is produced between the string and the air, by the return or the *result* of the string, which was strained by the touch to his former place. Bacon.

Such huge extremes, when nature doth unite,  
 Wonder from thence *results*, from thence delight. Denham.



Pleasure and peace do naturally *result* from a holy and good life. *Tillotson's Sermons.*

Buying of land is the *result* of a full and satiated gain : men in trade seldom lay money out upon land, till their profit has brought in more than trade can employ. *Locke.*

Upon the dissolution of the first earth, this very face or things would immediately *result*. *Burnet.*

These things are a *result* or judgment upon fact. *South.*

The horror of an object may overbear the pleasure *resulting* from its greatness. *Addison.*

With many a weary step, and many a groan,  
Up the high hill he heaves a huge round stone ;  
The huge round stone, *resulting* with a bound,  
Thunders impetuous down, and smokes along the ground. *Pope's Odyssey.*

Rude, passionate, and mistaken *results* have, at certain times, fallen from great assemblies. *Swift.*

Their effects are often very disproportionable to the principles and parts that *result* from the analysis. *Baker.*

RESUME', *v. a.* } Lat. *resumo*. To take  
RESUMABLE, *adj.* } back or again : resumable,  
RESUMPTION, *n. s.* } recoverable ; what may be  
taken back : resumption, the act of taking back.

That opportunity,

Which then they had to take from's, to *resume*  
We have again. *Shakespeare. Cymbeline.*

Wearied, forsaken, and pursued at last,

All safety in despair of safety placed,

Courage he thence *resumes*, resolved to bear

All their assaults, since 'tis in vain to fear.

*Denham.*

If there be any fault, it is the *resumption* or the swelling too long upon his arguments. *Id.*

He'll enter into glory and *resume* his seat.

*Milton.*

This was but an indulgence, and therefore *resumable* by the victor, unless there intervened any capitulation to the contrary. *Hale*

At this, with look serene, he raised his head,  
Reason *resumed* her place, and passion fled.

*Druden.*

They *resume* what has been obtained fraudulently, by surprise, and upon wrong suggestions. *Davenant.*

The universal voice of the people seeming to call for some kind of *resumption*, the writer of these papers thought it might not be unseasonable to publish a discourse upon grants. *Id.*

RESURVEY', *v. a.* Re and survey. To review ; survey again.

I have, with cursory eye, o'er glanced the articles ;  
Appoint some of your council presently  
To sit with us, once more with better heed  
To *resurvey* them. *Shakespeare. Henry V.*

RESURRECTION, *n. s.* Fr. *resurrection* ; Span. and Port. *resurecion* ; Lat. *resurrectio*. Revival from the dead ; return from the grave.

The Sadducees were grieved, that they taught and preached through Jesus the *resurrection* from the dead. *Acts iv. 2.*

Nor after *resurrection* shall he stay

Longer on earth, than certain times t' appear  
To his disciples. *Milton.*

Perhaps there was nothing ever done in all past ages, and which was not a publick fact, so well attested as the *resurrection* of Christ. *Watts.*

RESURRECTION, in theology, is that event the belief of which constitutes one of the principal articles in the Christian creed : and of which the wisest of the heathen philosophers had not the

most distant conception. Among the Jews, the belief of a future and separate existence for a long time was deemed no essential article of their creed ; but from different passages in Isaiah, Daniel, Ezekiel, and Job, many inferred the reality of a general resurrection. This resurrection appears to have been a general opinion among the Pharisees ; for although the Sadducees believed that there was no resurrection, neither angel nor spirit, yet the Pharisees confessed both. This resurrection of the dead to judgment is now generally, and almost universally, maintained by Christians. Numberless fanciful conjectures have been made respecting the manner in which the resurrection is to be accomplished ; the identity of the matter of the bodies raised, with that of those which died ; the place and state of the souls during their separation from the body, &c. ; but, as no decisive opinion can be formed on these subjects, we think it totally unnecessary to take up room with mere unsupported hypotheses. See THEOLOGY.

RESUSCITATE, *v. a.* } Lat. *resuscito*. To  
RESUSCITATION, *n. s.* } stir up anew ; revive :  
the noun substantive corresponding.

We have beasts and birds for dissections, though divers parts, which you account vital, be perished and taken forth, *resuscitating* of some that seem dead in appearance. *Bacon.*

Your very obliging manner of enquiring after me, at your *resuscitation*, should have been sooner answered ; I sincerely rejoice at your recovery. *Pope.*

RESUSCITATION, in medicine. See DROWNING.

RETAIL, *v. a. & n. s.* } Fr. *retailer* ; Ital. *re-*  
RETAILER, *n. s.* } *tuglio*. To redive ;  
sell in small quantities ; detail : such sale or division ; a retailer is a dealer in goods by retail.

He is furnished with no certainties,

More than he haply may *retail* from me.

*Shakespeare.*

From these particulars we may guess at the rest, as *retailers* do of the whole piece, by taking a view of its ends. *Hakewill.*

All encouragement should be given to artificers : and those who make should also vend and *retail* their commodities. *Locke.*

The author, to prevent such a monopoly of sense, is resolved to deal in it himself by *retail*. *Addison.*

The sage dame,

By names of toasts, *retails* each battered jade.

*Pope.*

We force a wretched trade by beating down the sale,

And selling basely by *retail*. *Swift's Miscellanies.*  
History, which ought to record truth and to teach wisdom, often sets out with *retailing* fictions and absurdities. *Robertson. History of Scotland.*

RETAIN', *v. a. & v. n.* } Fr. *retenir* ; Span. *re-*  
RETAINER, *n.* } *tener* ; Ital. *ritenere* ;

Lat. *retineo*. To keep as a possession ; keep in use, in service, or in pay : as a verb neuter, to belong to ; depend on : a retainer is an adherent ; dependent ; act of keeping dependents.

As they did not like to *retain* God in their knowledge, God gave them over to a reprobate mind. *Romans i. 22.*

Receive him that is mine own bowels ; whom I would have *retained* with me. *Philemon xii. 13.*

Where is the patience now,  
That you so oft have boasted to *retain*? *Shakespeare.*

You now are mounted,  
Where powers are your retainers. *Id.*

By another law, the king's officers and farmers  
were to forfeit their places and holds, in case of un-  
lawful *retainer*, or partaking in unlawful assemblies.  
*Bacon's Henry VII.*

Though the' offending part felt mortal pain,  
The' immortal part its knowledge did retain. *Denham.*

Be obedient, and retain  
Unalterably firm his love entire. *Milton.*

In animals many actions depend upon their living  
form, as well as that of mixtion, and, though they  
wholly seem to *retain* to the body, depart upon dis-  
union. *Browne.*

Although they *retain* the word mandrake in the  
text, yet they retract it in the margin. *Id.*

These betray upon the tongue no heat nor cor-  
rosiveness, but coldness, mixed with a somewhat  
fanguid relish *retaining* to bitterness. *Boyle.*

The vigour of this arm was never vain ;  
And that my wonted prowess I retain,  
Witness these heaps of slaughter. *Dryden.*

Whatever ideas the mind can receive and contem-  
plate without the help of the body, it is reasonable  
to conclude it can *retain* without the help of the  
body too. *Loeke.*

A Benedictine convent has now *retained* the most  
learned father of their order to write in its defence.  
*Adison.*

A combination of honest men would endeavour to  
extirpate all the profligate immoral *retainers* to each  
side, that have nothing to recommend them but an  
implicit submission to their leaders. *Id.*

One darling inclination of mankind affects to be a  
*retainer* to religion ; the spirit of opposition, that  
lived long before christianity, and can easily subsist  
without it. *Swift.*

RETAINING FEE, the first fee given to a serjeant  
or counsellor at law, in order to prevent his  
pleading on the contrary side.

RETAKE', *v. a.* Re and take. To take  
again.

A day should be appointed, when the remonstrance  
should be *retaken* into consideration. *Clarendon.*

RETALIATE, *v. a.* } *Lat. re and talio.* To  
RETALIATION. } return by giving like  
for like ; repay ; requite ; requital.

They thought it no irreligion to prosecute the se-  
verest *retaliation* or revenge ; so that at the same time  
their outward man might be a saint, and their inward  
man a devil. *South.*

God, graciously becoming our debtor, takes what  
is done to others as done to himself, and by promise  
obliges himself to full *retaliation*. *Calamy's Sermons.*

It is very unlucky to be obliged to *retaliate* the in-  
juries of authors, whose works are so soon forgotten  
that we are in danger of appearing the first aggressors.  
*Swift.*

RETARD', *v. a.* *Fr. retarder ; Lat. retardo.*  
To hinder ; to obstruct in swiftness of course.

Out of this a man may devise the means of altering  
the colour of birds, and the *retardation* of hoary  
hairs. *Bacon.*

This disputing way of enquiry is so far from ad-  
vancing science that it is no inconsiderable *retarder*.  
*Glanville.*

Some years it hath also *retarded*, and come far  
later than usually it was expected. *Browne.*

Nor kings nor nations  
One moment can *retard* the' appointed hour.  
*Dryden.*

RETCH'LESS, *adj.* Written *wretchless*,  
properly also *RECKLESS*, which see. *Careless* :

He struggles into breath, and cries for aid ;  
Then helpless in his mother's lap is laid :  
He creeps, he walks, and, issuing into man,  
Grudges their life from whence his own began ;  
*Retchless* of laws affects to rule alone. *Dryden.*

RETECTION, *n. s.* *Lat. retectus.* The act  
of discovering to view.

This is rather a restoration of a body to its own  
colour, or a *retection* of its native colour, than a  
change. *Boyle.*

RETENTIVE, *adj.* } *Fr. retentif ; Lat.*  
RETEN'TIVENESS, *n. s.* } *retentus.* Having the  
RETENTION. } power of retaining  
or withholding ; having memory : the noun sub-  
stantive corresponding.

It keepeth sermons in memory, and doth in that  
respect, although not feed the soul of man, yet help  
the *retentive* force of that stomach of the mind.  
*Hooker.*

No woman's heart  
So big to hold so much ; they lack *retention*.  
*Shakspeare.*

I sent the old and miserably king  
To some *retention* and appointed guard. *Id.*

Have I been ever free, and must my house  
Be my *retentive* enemy, my gaol ? *Id.*

To remember a song or tune, our souls must be in  
harmony continually running over in a silent whisper  
those musical accents, which our *retentive* faculty is  
preserver of. *Glanville.*

*Retention* is the keeping of those simple ideas,  
which from sensation or reflection the mind hath re-  
ceived. *Locke.*

The backward learner makes amends another way  
expiating his want of docility with a deeper and a  
more rooted *retention*. *South.*

In Tot'nam fields the brethren with amaze  
Prick all their ears up, and forget to graze ;  
Long Chancery-lane *retentive* rolls the sound,  
And courts to courts return it round and round.  
*P'ope*

RETFORD, EAST, a borough, market town,  
and parish of Nottinghamshire, near the river  
Idle, seven miles north from Tuxford, and 141  
north by west from London. The town is well  
built, has a free grammar-school, a hospital, and  
an alms-house ; also a town-hall, in which the  
sessions for the town are held. The county as-  
sises are held here, alternately with Nottingham.  
The church, called the Corporation, is a neat  
Gothic building, with a handsome square tower.  
The environs of this town abound in hop planta-  
tions, and a canal to the Trent passes near it.  
The manufactures are chiefly those of hats and  
sail-cloth. It is incorporated under two bailiffs,  
a steward, and twelve aldermen, and sends two  
members to parliament ; the right of election is  
in the corporation and freemen. The market on  
Saturday is well supplied with hops, corn, malt,  
and provisions.

RETIARI, in antiquity, gladiators who  
fought in the Roman amphitheatre. They were  
dressed in a short coat, having a fuscina or tri-  
dent in the left hand, and a net in the right.  
With this they endeavoured to entangle their ad-  
versaries, that they might then with their trident  
despatch them : on their heads they wore only a  
hat, tied under the chin with a broad riband.

RETICULA, or RETICULE. in astronom

is a contrivance for measuring the exact quantity of eclipses. This instrument, introduced by the Academy of Sciences at Paris, is a little frame consisting of thirteen fine threads, parallel and equidistant from each other, placed in the focus of the object-glasses of telescopes; that is, in the place where the image of the luminary is painted in its full extent; consequently the diameter of the sun or moon is hereby seen divided into twelve equal parts or digits; so that, to find the quantity of the eclipse, there is nothing to do but to number the luminous and the dark parts. As a square reticule is only proper for the diameter, not for the circumference, of the luminary, it is sometimes made circular by drawing six concentric equidistant circles. This represents the phases of the eclipse perfectly. See **ASTRONOMY**.

**RETICULATED**, *adj.* Latin *reticulatus*. Made of network; formed with interstitial vacancies.

The intervals of the cavities, rising a little, make a pretty kind of *reticulated* work.

*Woodward on Fossils.*

**RETICULUM**, Lat., i. e. a little or casting net, was applied by the Romans to a particular mode of constructing their buildings. In the city of Salino are still to be seen remains of some walls, evidently of Roman origin from the reticulum. This structure consists of small pieces of baked earth cut lozengewise, and disposed with great regularity on the angles, so as to exhibit to the eye the appearance of cut diamonds; and was called reticular from its resemblance to fishing nets. The Romans always concealed it under a coating.

**RETIFORM**, *adj.* Lat. *retiformis*. Having the form of a net.

The uveous coat and inside of the choroides are blackened, that the rays may not be reflected backward to confound the sight; and, if any be by the *retiform* coat reflected, they are soon choked in the black inside of the uvea. *Ray.*

**RETIMO**, sometimes called Rhetzmo, a seaport of Candia, situated on the north coast of the island, about forty miles west of the town of Candia. It extends a considerable way along the shore, and has still a citadel, on a sharp projecting rock, built, as well as a fort at the other end of the town, for the protection of the harbour. The latter is now in ruins, and the port itself almost blocked up with sand. The population amounts to about 6000, employed for the most part in agriculture and the culture of the vine, or in making soap from olive oil. Long. 24° 21' E., lat. 35° 20' N.

**RETINA**, in anatomy, the expansion of the optic nerves over the bottom of the eye, where the sense of vision is first received. See **ANATOMY** and **OPTICS**.

**RETINUE**, *n. s.* Fr. *retenue*; Ital. *ritenuti*, of Lat. *retinco*. A number attending upon a principal person; a train.

Not only this your ill-licensed fool,

But other of your insolent *retinue*,

Do hourly carp and quarrel.

What followers, what *retinue* can'st thou gain,  
Or at thy heels the dizzy multitude,  
Longer than thou can'st feed them on thy cost

*Milton.*

There appears

The long *retinue* of a prosperous reign,

A series of successful years.

*Dryden.*

**RETRADE**, in fortification, a kind of re-trenchment made in a body of a bastion, or other work, which is to be disputed inch by inch after the defences are dismantled. It usually consists of two faces, which make a re-entering angle. When a breach is made in a bastion, the enemy may also make a *retirade* or new fortification behind it.

**RETIRE**, *v. a., v. n. & n. s.*

**RETIRE'DNESS**, *n. s.*

**RETIRE'MENT**.

retreat; go off; leave company; take away: as a noun substantive (obsolete), retreat; recession; place of privacy: retiredness corresponding: retirement is the act of withdrawing; private abode or habit; state of being withdrawn.

Set up the standard towards Zion, *retire*, stay not.

*Jeremiah.*

He brake up his court, and *retired* himself, his wife, and children into a forest thereby.

*Sidney.*

He, our hope, might have *retired* his power  
And driven into despair an enemy's hate.

*Shakspeare.*

I heard his praises in pursuit,

But ne'er, till now, his scandal of *retire*.

*Id.*

There may be as great a variety in *retiring* and withdrawing men's conceit in the world, as in obtruding them.

*Bacon.*

The battle and the *retire* of the English succours were the causes of the loss of that dutchy.

*Id.*

The mind contracts herself, and shrinketh in,

And to herself she gladly doth *retire*.

*Davies.*

The parliament dissolved, and gentlemen charged to *retire* to their country habitations.

*Hayward.*

Like one, who in her third widowhood doth profess

Herself a nun, ty'd to *retiredness*,

So affects my muse now a chaste fallowness.

*Donne.*

Language most shews a man; speak that I may see thee; it springs out of the most *retired* and inmost parts of us.

*Ben Jonson.*

After some slight skirmishes, he *retired* himself into the castle of Farnham.

*Clarendon.*

My *retirement* there tempted me to divert those melancholy thoughts.

*Denham's Dedication.*

Thou open'st wisdom's way,

And giv'st access, though secret she *retire*.

*Milton.*

Eve, who unseen

Yet all had heard with audible lament,

Discovered soon the place of her *retire*.

*Id.*

Short *retirement* urges sweet return.

*Id.*

Hydra-like, the fire

Lifts up his hundred heads to aim his way;

And scarce the wealthy can one-half *retire*,

Before he rushes in to share the prey.

*Dryden.*

Some, accustomed to *retired* speculations, run natural philosophy into metaphysical notions and the abstract generalities of logic.

*Locke.*

While you, my lord, the rural shades admire,

And from Britannia's publick posts *retire*,

Me into foreign realms my fate conveys.

*Addison.*

Caprea had been the *retirement* of Augustus for some time, and the residence of Tiberius for many years.

*Id.*

The old fellow scuttled out of the room, and *retired*.

*Arbutnot.*

How could he have the leisure and *retiredness* of the cloister, to perform all those acts of devotion in,

when the burthen of the reformation lay upon his shoulders?

Performed what friendship, justice, truth require,  
What could he more, but decently retire? *Swift.*

An elegant sufficiency, content,  
*Retirement*, rural quiet, friendship, books,  
Progressive virtue, and approving heaven.

He has sold a small estate that he had, and has  
erected a charitable *retirement*, for ancient poor people  
to live in prayer and piety.

RETOLD, *part. pass.* of retell. Related or  
told again.

Upon his dead corpse there was such misuse  
By those Welchwomen done, as may not be  
Without much shame *retold* or spoken of.

RETORT, *v. a. & n. s.* } *Lat. retortus.* To  
RETORTER, *n. s.* } throw or curve back;  
RETORTION. } rebound; return in  
argument or censure: the censure or repartee;  
a chemical vessel. See below. All the noun-  
substantives correspond.

His virtues, shining upon others,  
Heat them, and they *retort* that heat again  
To the first giver.

I said his beard was not cut well, he was in the  
mind it was; this is called the *retort* courteous.

It would be tried how the voice will be carried in  
an horn, which is a line arched; or in a trumpet,  
which is a line *retorted*; or in some pipe that were  
sinuous.

His proof will easily be *retorted*, and the contrary  
proved.

He passed through hostile scorn;  
And with *retorted* scorn his back he turned.  
Recent urine distilled yields a limpid water; and  
what remains at the bottom of the *retort* is not acid  
nor alkaline.

The respondent may shew how the opponent's argu-  
ment may be *retorted* against myself.

When, by repeated evaporations, the whole of the  
soda and neutral salts are separated, remove the re-  
maining liquor to a tubulated glass *retort*, adapt a re-  
ceiver to it, and, when this is properly luted, pour some  
concentrated sulphuric acid upon the liquor within  
the *retort*, and proceed to distillation.

*Parker's Chemical Catechism.*

RETORTS, in chemistry, are vessels em-  
ployed for many distillations, and most fre-  
quently for those which require a degree of heat  
superior to that of boiling water. This vessel is  
a kind of bottle with a long neck, so bent that it  
makes, with the belly of the retort, an angle of  
about sixty degrees. From this form they have  
probably been named retorts. The most capacious  
part of the retort is called its belly. Its upper  
part is called the arch or roof of the retort, and  
the bent part is the neck. They differ in form  
and materials: when pierced with a little hole in  
their roof, they are called tubulated retorts.  
They are made of common glass, stone-ware, and  
iron. See CHEMISTRY and LABORATORY. In  
the Transactions of the Society for Encourage-  
ment of Arts, we find a paper containing a  
method for preventing stone retorts from break-  
ing; or stopping them when cracked, during  
any chemical operation, without removing any  
of the contents. 'I have always found it neces-  
sary,' says the writer, 'to use a previous coating  
for filling up the interstices of the earth or stone,

which is made by dissolving two ounces of  
borax in a pint of boiling water, and adding to  
the solution as much slaked lime as will make it  
into a thin paste; this, with a common painter's  
brush, may be spread over several retorts, which,  
when dry, are then ready for the proper pre-  
serving coating. The intention of this first  
coating is, that the substances thus spread over,  
readily vitrifying in the fire, may prevent any of  
the distilling matters from pervading the retort,  
but do in no wise prevent it from cracking. When-  
ever I want to use any of the above coated re-  
torts, after I have charged them with the sub-  
stance to be distilled, I prepare a thin paste,  
made with common linseed oil and slaked lime  
well mixed, and perfectly plastic, that it may be  
easily spread: with this let the retorts be covered  
all over, except that part of the neck which is to  
be inserted into the receiver; this is readily done  
with a painter's brush: the coating will be suf-  
ficiently dry in a day or two, and they will then  
be fit for use. With this coating I have for  
several years worked my stone retorts, without  
any danger of their breaking, and have frequently  
used the same retort four or five times; observing  
particularly to coat it over with the last men-  
tioned composition every time it is charged with  
fresh materials: before I made use of this ex-  
pedient, it was an even chance, in conducting  
operations in stone and earthen retorts, wheth-  
er they did not crack every time, by which means  
great loss has been sustained. If at any time  
during the operation the retort should crack,  
spread some of the oil composition thick on the  
part, and sprinkle some powder of slaked lime  
on it, and it immediately stops the fissure, and  
prevents any of the distilling matter from per-  
vading; even phosphorus will not penetrate  
through it. It may be applied without any  
danger, even when the retort is red hot; and,  
when it is made a little stiffer, is more proper  
for luting vessels than any I ever have tried; be-  
cause, if properly mixed, it will never crack,  
nor will it indurate so as to endanger the break-  
ing the necks of the vessels when taken off.'

RETOSS, *v. a.* Re and toss. To toss back.  
Tossed and *retoss* the ball incessant flies.

RETOUCH, *v. a.* Fr. *retoucher*. To touch  
anew; improve by new touches.

He furnished me with all the passages in Aristotle  
and Horace, used to explain the art of poetry by  
painting; which, if ever I *retouch* this essay, shall  
be inserted.

Lintot, dull rogue! will think your price too  
much;

'Not, Sir, if you revise it and *retouch*.'

RETRACE, *v. a.* Fr. *retracer*. To trace  
back; or again.

Then if the line of Turnus you *retrace*,  
He springs from Inachus of Argive race.

RETRACT, *v. a. & v. n.* } Fr. *retracter*;  
RETRACT'ION, *n. s.* } Lat. *retractus*. To  
RETRACT'ION. } recall; recant; to

take back; resume; to unsay: retractation is,  
change of declared opinion; recantation: *retraction*,  
act of withdrawing a declared opinion or  
claim; a change of measures; declaration of  
change.

There came into her head certain verses, which i

she had had present commodity, she would have adjoined as a *retraction* to the other. *Sidney.*

Were I alone to pass the difficulties,  
Paris should ne'er *retract* what he hath done,  
Nor faint in the pursuit. *Shakespeare.*

If his subtilities could have satisfied me, I would as freely have *retracted* this charge of idolatry, as I ever made it. *Stillingfleet.*

These words are David's *retraction*, or laying down of a bloody and revengeful resolution. *South.*

They make bold with the deity, when they make him do and undo, go forwards and backwards by such countermarches and *retractions* as we do not repute to the Almighty. *Woodward.*

She will, and she will not, she grants, denies, Consents, *retracts*, advances, and then flies. *Granville.*

**RETREAT,** *n. s. & v. a.* French *retraite*. [Written formerly *retract* and *retrait*.] Act of retiring; state or place of retirement or security: to go back; go to a private abode.

Upon her eyelids many graces sat,  
Under the shadow of her even brows,  
Working bellgards and amorous *retraite*,  
And every one her own with grace endows. *Spenser.*

The earl of Lincoln, deceived of the country's concourse unto him, and seeing the business past *retract*, resolved to make on where the king was, and give him battle. *Bacon.*

This place our dungeon, not our safe *retreat*  
Beyond its potent arm. *Milton.*

None thought of flight,  
None of *retreat*. *Id.*

Others more mild  
*Retreated* in a silent valley, sing  
Their own heroic deeds. *Id.*

That pleasing shade they sought, a safe *retreat*  
From sudden April showers, a shelter from the heat. *Dryden.*

He built his son a house of pleasure, and spared no cost to make a delicious *retreat*. *I. Estrange.*

There is no such way to give defence to absurd doctrines, as to guard them round with legions of obscure and undefined words; which yet make these *retreats* more like the dens of robbers, than the fortresses of fair warriors. *Locke.*

Holy *retreat*, sithence no female thither  
Must dare approach from the inferiour reptile  
To woman, form divine. *Prior.*

Having taken her by the hand, he *retreated* with his eye fixed upon her. *Arbuthnot and Pope.*

But beauty's triumph is well-timed *retreat*,  
As hard a science to the fair as great. *Pope.*

**RETREAT**, in a military sense. An army or body of men are said to retreat when they turn their backs upon the enemy, or are retiring from the ground they occupied: hence every march in withdrawing from the enemy is called a retreat. That which is performed in sight of an active enemy, who pursues with a superior force, is the most important; and is a manœuvre the most calculated to display the prudence, courage, and address, of an officer who commands. The most famous retreat in ancient history was that of Xenophon.

**RETREAT** is also a beat of the drum, at the firing of the evening gun; at which the drum-major, with all the drums of the battalion, except such as are upon duty, beats from the camp-colors on the right to those on the left, on the parade of the encampment: the drums of all the

guards beat also, the trumpets at the same time sounding at the head of their respective troops. This is to warn the soldiers to forbear firing, and the sentinels to challenge, till the break of day that the reveille is beat. The retreat is likewise called setting the watch.

**RETRENCH,** *v. a. & v. n.* } Fr. *retrancher*.  
**RETRENCHMENT,** *n. s.* } To cut off; pare away; confine; live within narrow limits, as to expense: the act of lopping away; entrenchment.

The pruner's hand must quench  
Thy heat, and thy exuberant parts *retrench*. *Denham.*

Nothing can be added to the wit of Ovid's *Metamorphoses*; but many things ought to have been *retrenched*. *Dryden.*

In some reigns they are for a power and obedience that is unlimited; and in others are for *retrenching*, within the narrowest bounds, the authority of the princes, and the allegiance of the subject. *Addison's Freeholder.*

The want of vowels in our language has been the general complaint of our politest authors, who nevertheless have made these *retrenchments*, and consequently increased our former scarcity. *Addison.*

We ought to *retrench* those superfluous expenses to qualify ourselves for the exercise of charity. *Atterbury.*

Can I *retrench*? yes, mighty well,  
Shrink back to my paternal cell,  
A little house, with trees a-row,  
And, like its master, very low. *Pope.*

**RETRENCHMENT**, in the art of war, any kind of work raised to cover a post, and fortify it against the enemy.

**RETRIBUTÉ,** *v. a.* } Fr. *retribuer*; Lat.  
**RETRIB'UTER,** *n. s.* } *retribuo*. To pay  
**RETRIBUT'ION,** } back; make repay-  
**RETRIB'UTOR,** *adj.* } ment of; all the deri-  
**RETRIBUTIVE.** } vatives corresponding.

The king thought he had not remunerated his people sufficiently with good laws, which evermore was his *retribution* for treasure. *Bacon's Henry VII.*

In good offices and due *retributions*, we may not be pinching and niggardly: it argues an ignoble mind, where we have wronged to higgel and dodge in the amends. *Hall.*

All who have their reward on earth, the fruits  
Of painful superstition, and blind zeal,  
Nought seeking but the praise of men, here find  
Fit *retribution*, empty as their deeds. *Milton.*

Both the will and power to serve him are his upon so many scores, that we are unable to *retribute*, unless we do restore; and all the duties we can pay our Maker are less properly requitals than restitutions. *Boyle.*

There is no nation, though plunged into never such gross idolatry, but has some awful sense of deity, and a persuasion of a state of *retribution* to men after this life. *South.*

It is a strong argument for a state of *retribution* hereafter, that in this world virtuous persons are very often unfortunate, and vicious persons prosperous. *Addison's Spectator.*

Something strangely *retributive* is working. *Clarissa.*

**RETRIEVE,** *v. a.* Fr. *retrouver*. To recover; restore; repair; regain.

With late repentance now they would *retrieve*  
The bodies they forsook, and wish to live. *Dryden.*

Philomela's liberty *retrieved*,  
Cheers her sad soul. *Philips.*

O reason! once again to thee I call;  
Accept my sorrow, and retrieve my fall. *Prior.*  
If one, like the old Latin poets, came among  
them, it would be a means to retrieve them from their  
cold trivial conceits, to an imitation of their prede-  
cessors. *Berkeley to Pope.*

**RETROCESSION**, *n. s.* Lat. *retrocessum*.  
The act of going back.

These bursts of light, and involutions of darkness,  
these transient and involuntary excursions and re-  
trocessions of invention, having some appearance of  
deviation from the common train of nature, are  
eagerly caught by the lovers of a wonder. *Johnson.*

**RETROCOPULATION**, *n. s.* Retro and  
copulation. Postcoition.

From the nature of this position, there ensueth a  
necessity of retrocopulation. *Broune.*

**RETROGRADE**, *adj. & v. n.* } Fr. *retro-*  
**RETROGRESSION**, *n. s.* } *grade*; Lat.  
*retro* and *gradior*. Going backward; opposite  
or contrary; to go backward: the act of doing  
so.

Your intent

In going back to school to Wittenberg,  
It is most retrograde to our desire. *Shakspeare.*  
Princes, if they use ambitious men, should handle  
it so, as they be still progressive, and not retrograde.

*Bacon.*

Their wand'ring course, now high, now low, then  
hid,

Progressive, retrograde, or standing still,  
In six thou seest. *Milton's Paradise Lost.*

The account, established upon the rise and descent  
of the stars, can be no reasonable rule unto distant  
nations, and by reason of their retrogression, but  
temporary unto any one. *Broune.*

Two geomantick figures were displayed;  
One when direct, and one when retrograde.

*Dryden.*

As for the revolutions, stations, and retrogradations  
of the planets, observed constantly in most certain  
periods of time, it sufficiently demonstrates, that their  
motions are governed by counsel. *Ray.*

**RETROMINGENCY**, *n. s.* } Latin *retro*  
**RETROMINGENT**, *adj.* } and *mingo*.  
The quality of staling backwards: the adjective  
corresponding.

The last foundation was retromingency, or pissing  
backwards; for men observing both sexes to urinate  
backwards, and aversly between their legs, they might  
conceive there were feminine parts in both.

*Broune's Vulgar Errors.*

By reason of the backward position of the femi-  
nine parts of quadrupeds, they can hardly admit the  
substitution of masculine generations, except it be  
in retromingents. *Broune.*

**RETROSPECT**, *n. s.* } Lat. *retro* and *spe-*  
**RETROSPECTION**. } *cio*. Look throun  
**RETROSPECTIVE**, *adj.* } upon things behind  
or things past: act or faculty of looking back;  
looking backwards.

As you arraign his majesty by retrospect, so you  
condemn his government by second sight.

*Addison's Freeholder.*

In vain the grave, with retrospective eye,  
Would from the' apparent what conclude the why.

*Pope.*

Can'st thou take delight in viewing  
This poor isle's approaching ruin,  
When thy retrospection vast  
Sees the glorious ages past?

Happy nation were we blind,  
Or had only eyes behind.

*Sayst.*

**RETUND**, *v. a.* Lat. *retundo*. To blunt;  
turn.

Covered with skin and hair keeps it warm,  
being naturally a very cold part, and also to quench and  
dissipate the force of any stroke that shall be dealt  
it, and retund the edge of any weapon. *Ray.*

**RETURN**, *v. n., v. a., &* } Fr. *retourner*;  
**RETURNABLE**, *adj.* [*n. s.*] } re and turn. To  
**RETURNER**, *n. s.* } come or go back;  
**RETURNLESS**, *adj.* } come again; come

again to the beginning of a series; retort; re-  
cognate; answer: to repay; give or send back;  
transmit; give account of: as a noun substan-  
tive, the act of coming, going, restoring, or paying  
back; revolution; retrogression; profit; advan-  
tage; remittance: returnable is, in law, allowed  
to be reported back: returner, he who pays  
money: returnless, not admitting return.

Return him a trespass offering. 1 Samuel vi. 3.  
Thy Lord shall return thy wickedness upon thine  
own head. 1 Kings ii. 44.

At the return of the year, the king of Syria will  
come up. Id. xx. 22.

Whoso rolleth a stone, it will return upon him.  
*Proverbs xxvi.*

I am in blood

Step't in so far, that, should I wade no more,  
Returning were as tedious as go o'er. *Shakspeare.*

The thing of courage,

As roused with rage, with rage doth sympathize;  
And, with an accent tuned in self-same key,  
Returns to chiding fortune. *Id.*

The king of France so suddenly gone back!  
—Something since his coming forth is thought of,  
That his return was now most necessary. *Id.*

Within these two months, I do expect return  
Of thrice three times the value of this bond. *Id.*

Weapons hardly fall under rule; yet even they  
have returns and vicissitudes; for ordnance was  
known in the city of the Oxidraes in India, and is  
what the Macedonians called thunder and lightning.

*Bacon's Essays.*

As for any merchandise you have bought, ye shall  
have your return in merchandise or gold. *Bacon.*

As to roots accelerated in their ripening, there is  
the high price that those things bear, and the swift-  
ness of their returns; for, in some grounds, a radish  
comes in a month, that in others will not come in  
two, and so make double returns. *Id.*

But well knew the troth

Of this thine own returne, though all my friends,  
I knew as well should make returnesse ends.

*Chapman.*

The fruit, from many days of recreation, is very  
little; but from these few hours we spend in prayer,  
the return is great. *Taylor.*

Instead of a ship, he should levy money, and re-  
turn the same to the treasurer for his majesty's use.

*Clarendon.*

On their embattled ranks the waves return.

*Milton.*

With the year

Seasons return, but not to me returns  
Day, or the sweet approach of even or morn. *Id.*

When answer none returned, I set me down. *Id.*  
Reject not then what offered means; who knows  
But God hath set before us, to return thee  
Home to thy country and his sacred house? *Id.*

Probably one fourth part more died of the plague  
than are returned. *Gravum's Bills of Mortality.*

It may be decided in that court where the verdict is *returnable*. *Hals.*

If you are a malicious reader, you *return* upon me that I affect to be thought more impartial than I am. *Dryden.*

When forced from hence to view our parts he mourns;

Takes little journies, and makes quick *returns*. *Id.*

A flaw is in thy ill-baked vessel found;

'Tis hollow, and *returns* a jarring sound. *Id.*

If they *returned* out of bondage, it must be into a state of freedom. *Locke.*

Brokers cannot have less money by them than one twentieth part of their yearly *returns*. *Id.*

The chapmen, that give highest for this, can make most profit by it, and those are the *returners* of our money. *Id.*

Either of the adjoining sides of the front of an house or groundplot is called a *return* side. *Hoxon's Mechanical Exercises.*

The other ground of God's sole property in any thing is the gift, or rather the *return* of it made by man to God. *South.*

Ungrateful lord!

Would'st thou invade my life, as a *return*

For proffered love? *Rowe.*

He shall have an attachment against the sheriff, directed to the coroner, and *returnable* into the king's bench. *Ayliffe.*

*Returns*, like these, our mistress bids us make, When from a foreign prince a gift her Britons take. *Prior.*

Since these are some of the *returns* which we made to God, after obtaining our successes, can we reasonably presume that we are in the favour of God? *Atterbury.*

This is breaking into a constitution to serve a present expedient; the remedy of an empirick, to stifle the present pain, but with certain prospect of sudden *returns*. *Swift.*

He said; and thus the queen of heaven *returned*, Must I, oh Jove, in bloody wars contend? *Pope.*

The all of thine that cannot die

Through dark and dread Eternity,

*Returns* again to me,

And more thy buried love endears

Than ought, except its living years. *Byron.*

RETURN, RETURNA, or RETOURNA, in law, is used in divers senses. 1. Return of writs by sheriffs and bailiffs is a certificate made by them to the court, of what they have done in relation to the execution of the writ directed to them. This is written on the back of the writ by the officer, who thus sends the writ back to the court whence it issued, to be filed. 2. Return of a commission, a certificate or answer sent to the court whence the commission issues, concerning what has been done by the commissioners. 3. Returns, or days in bank, are certain days in each term, appointed for the return of writs, &c.

RETZAT, the name of two rivers and a creek of Bavaria: the latter has an area of 3400 square miles, and 520,000 inhabitants. The capital is Anspach.

RETZIA, in botany, a genus of the monogynia order, and pentandria class of plants, natural order twenty-ninth, campanacæ: caps. bilocular: cor. cylindrical, villous without, stigma bifid.

REU, the son of Peleg, father of Serug, and great-grandfather of Abraham. He was born

about the time of the division of the earth, and died in his 207th year.

REUCHLIN, or CAPNIO (John), LL. D. a learned German, born at Pforzheim, in 1450. He went to Paris with the bishop of Utrecht, where he studied grammar under John de Lapide, rhetoric under Gaguinus, Greek under Tiphernus, and Hebrew under Wesselus. He became doctor of philosophy at Basil in 1749, and LL.D. of Orleans; where he taught Greek, and published a grammar, lexicon, and vocabularies, in that language. He next went to Rome, where Hermolaus Barbarus persuaded him to change his name to Capnio, which in Greek means the same as Reuchlin in German, i. e. smoke. He was made ambassador to Frederick III., who granted him many favors, but after that emperor's death he was banished, and went to Worms, where the elector palatine employed him to defend his cause at Rome, where he made a celebrated oration before the pope on the rights of the German princes and churches. He revived the study of Hebrew, and died in 1522. The *Epistolæ Obscurorum Virorum* are ascribed to him.

REVE, *n. s.* Sax. *gerefa*, a governor. The bailiff of a franchise or manor.

The *reve*, the miller, and the mincing lady *priores*, speak in character. *Dryden.*

REVEAL, *v. a.* } Fr. *reveler*; Lat. *revelo*.  
REVEAL'ER, *n. s.* } To show; discover; lay  
REVELA'TION. } open: the noun substantives corresponding.

The sufferings of this life are not to be compared with the glory which shall be *revealed* in us. *Romans* viii. 18.

Be ashamed: speaking again that which thou hast heard, and *revealing* of secrets. *Ecclus.* xli. 23.

The habit of faith in divinity is an argument of things unseen, as a stable assent unto things inevitable, upon authority of the divine *revealer*.

*Broune's Vulgar Errors.*

Light was the wound, the prince's care unknown, She might not, would not, yet *reveal* her own. *Wallier.*

He brought a taper; the *revealer* light Exposed both crime and criminal to sight. *Dryden.*

Thy throne is darkness in the abyss of light, A blaze of glory that forbids the sight; O teach me to believe thee thus concealed, And search no further than thyself *revealed*. *Id.*

The answer to one who asked what time was, si non rogas intelligo—that is, the more I think of time, the less I understand it—might persuade one, that time, which *reveals* all other things, is itself not to be discovered. *Lacine.*

When the divine *revelations* were committed to writing, the Jews were such scrupulous reverers of them, that they numbered even the letters of the Old Testament. *Decay of Piv.*

As the gospel appears in respect of the law to be a clearer *revelation* of the mystical part, so it is a far more benign dispensation of the practical part. *Sprat.*

The lives of the *revealers* may be justly set *over* against the *revelation*, to find whether they agree. *Atterbury.*

REVEILLE, a beat of drum about break of day, to give notice that it is time for the *soldiers* to arise, and that the sentries are to forbear *challenging*.

REV'EL, v. n. } Skinner derives it from  
 REV'ELLER, n. s. } Fr. *reveiller*, to awake; Lye  
 REV'ELRY, } from Belg. *raveelen*, to rove  
 REVEL-ROUT. } loosely about, which is  
 countenanced by the old phrase, revel-rout.  
 Perhaps all are from Lat. *re* and *vigilia*. To  
 feast with clamorous merriment: and (of Lat.  
*revellō*), to drive back: revelry is, jollity; mirth:  
 reveller, one who indulges in revels: revel-rout,  
 a tumult; tumultuous festivity.

My honey love,  
 Will we return unto thy father's house,  
 And *revel* it as bravely as the best. *Shakspeare.*  
 We shall have *revelling* to-night;  
 I will assume thy part in some disguise. *Id.*  
 Let them pinch the unclean knight,  
 And ask him, why, that hour of fairy *revel*,  
 In their so sacred paths he dares to tread? *Id.*  
 Fairies, black, grey, green, and white,  
 You moonshine *revellers*, attend your office. *Id.*  
 Forget this new-fallen dignity,  
 And fall into our rustic *revelry*. *Id.*  
 Were the doctrine new,  
 That the earth moved, this day would make it true;  
 For every part to dance and *revel* goes,  
 They tread the air, and fall not where they rose. *Donne.*

He can report you more odd tales  
 Of our outlaw Robin Hood,  
 That *revelled* here in Sherewood,  
 Though he ne'er shot in his bow. *Ben Jonson.*  
 Those who miscarry escape by their flood *revel-*  
*ling* the humours from their lungs. *Harvey.*  
 There let Hymen oft appear  
 In saffron robe with taper clear,  
 And pomp, and feast and *revelry*,  
 With mask and antick pageantry. *Milton.*  
 For this his minion, the *revel-rout* is done. *Rowe.*  
 Venesection in the left arm does more immediate  
*revel*, yet the difference is minute.

*Friend's History of Physic.*  
 Unwelcome *revellers*, whose lawless joy  
 Pains the sage ear, and hurts the sober eye. *Pope.*  
 While youth's hot wishes in our red veins *revel*,  
 We know not this—the blood flows on too fast;  
 But as the torrent widens towards the ocean,  
 We ponder deeply on each past emotion. *Byron.*

REVEL, a town of France, in the depart-  
 ment of the Upper Garonne, is situated not far  
 from the great canal of Languedoc. It has a  
 population of 3800, who manufacture woollens,  
 linen, stockings, and caps. During the civil  
 wars of the sixteenth century it was taken and  
 fortified by the Calvinists, but afterwards dis-  
 mantled. Thirty miles south-east of Toulouse.

REVELATION is the act of revealing or making  
 a thing public that was before unknown; it is  
 also used for the discoveries made by God to  
 his prophets, and by them to the world; and  
 more particularly for the books of the Old and  
 New Testament. See BIBLE, CHRISTIANITY,  
 MIRACLE, PROPHECY, RELIGION, and THEO-  
 LOGY. The principal tests of the truth of any  
 revelation are, the tendency of its practi-  
 cal doctrines; its consistency with itself, and  
 with the known attributes of God; and some  
 satisfactory evidence that it cannot have been  
 derived from a human source. In every reve-  
 lation confirmed by this evidence many doc-  
 trines are to be looked for which human reason  
 cannot fully comprehend; and these are to be

believed on the testimony of God, and suffered  
 to produce their practical consequences. This  
 kind of belief has place in arts and sciences, as  
 well as in religion. Whoever avails himself of  
 the demonstrations of Newton, Bernoulli, and  
 others, respecting the resistance of fluids, and  
 applies their conclusions to the art of ship-  
 building, is as implicit a believer, if he under-  
 stand not the principles of fluxions, as any  
 Christian; and yet no man will say that his faith  
 is not productive of important practical con-  
 sequences.

This is a subject respecting which we have  
 felt a strong desire to be at once plain and  
 copious in the present work; and, for reasons  
 which will appear at the close, what may  
 seem briefly discussed in this article will be  
 resumed in that of THEOLOGY. As a country  
 we are recovering—and but recovering—in  
 common with the other nations of Europe from  
 the storm of infidelity and every sort of discord  
 which began in revolutionary France. During  
 its progress not only new and excellent expo-  
 sitions and defences of the evidences of our faith  
 have appeared in England and placed the whole  
 subject in renewed and living light, but one of  
 the greatest moral experiments upon infidelity  
 that was ever tried, or that perhaps ever can be  
 tried, may be said to have been completed.  
 Lardner and Paley and Porteus and Watson  
 (to say nothing of existing writers) must on the  
 other hand have lived in vain, if the evidences  
 of Christianity may not be popularised with  
 more facility, and left to their own fair effect  
 upon the minds of men with more confidence  
 than ever; while on the other hand it will in-  
 deed appear that nations are never to profit by  
 experience, if the international history of Eu-  
 rope for the last thirty years shall not give new  
 scope to the arguments for Christianity, and show  
 the true tendencies of atheism.

Connected with these great facts, and by no  
 means inferior to any other consideration in our  
 view of its importance, is the interesting situa-  
 tion of this country at the present period, with  
 regard to education and the circulation of the  
 Bible. How mightily calculated to act upon  
 each other are the noble engines which are every-  
 where at work to promote these objects! But  
 the more we attempt to educate all classes, and  
 especially those neglected groupes of society to  
 whom education and all its advantages are no-  
 velties, the more in all the ardor of novelty must  
 we expect to see the spirit of enquiry rising  
 about us—and the real taste of truth mingling  
 with much of the pride of supposed discoveries  
 in morals and religion. Each class of society,  
 too, will act strongly, and, on the whole, bene-  
 ficially on every other; while all classes will be  
 stimulated more than ever to discuss every thing  
 they have believed or are taught to believe. The  
 cultivation of the mind educes enquiry: but sorry  
 we are to add that some distinguished promoters  
 of liberal enquiry have been, at any rate, im-  
 agined, to be indisposed to religion; and to  
 slight its evidences. Here arises therefore a  
 double reason for the plain and full exhibition  
 of them: it is due at once to science and  
 religion.



We should state the *presumption* in favor of revealed religion (to trace the argument fairly from its origin) in the following way. There is a God and He is infinitely benevolent. In the boundless heavens, the teeming earth, the cheerful seas, He has opened volumes of truth and wisdom inviting every eye. We have read them with attention, we claim the privilege of thinking and reasoning about them with impartiality and independence of mind; and whether by the light of science we search the arcana of nature, or confine ourselves to those observations on her works which may be as easily made by the ploughman as by the philosopher, no *one* truth is supported by such variety of proof as the being of a beneficent Author of all: springs of happiness, evidently designed, open every where at our feet, and supply the unquestionable sources of natural religion.

One thing however is left unsatisfied—the human mind. Nature teaches us to ask questions about her God which she cannot answer. This is an anomaly. Every thing seems to lead up to man: he has a more exquisitely finished form than any creature of his size, and a power of reflection, and therefore of anticipation, possessed by no other creature: he arrives at the position with which we have commenced; he finds it the capital truth of nature, without which all the conclusions of science are half-truths only, but he cannot proceed. The very being of nature's God seems to include a hearty determination in God to make his creatures happy, by adapting an object to every faculty of enjoyment; and all their senses are faculties of enjoyment. But here is an appetite for truth unprovided for; either therefore this must remain an inexplicable mystery, or rather a contradiction to the whole series of facts that argue a benevolent designer in the works of nature, or nature herself suggests the highest probability of a further revelation from God; and here we rest the connexion between natural and revealed religion. We have some hope of all who 'desire to retain God in their knowledge,' and would reason with all who avow that desire. The Bible professes to contain that revelation from God which every consistent deist must be enquiring for—it demands 'a reasonable service' only, from its most devout admirers, and can therefore have nothing to fear from an investigation of its claims. *He who hates a man for not being a Christian is not himself a Christian*, lord Littleton has well said. Weak Christians and violent sceptics are each likely to be improperly affected by the revival of the deistical controversy,—the former by undue apprehensions, the latter by a premature exultation; but, whether the triumphs of the one or the fears of the other are to be realised, we deem it a paramount duty to request both, as much as possible, to suppress mere emotions, and in the spirit of untrembling deliberation to allow the arena to be cleared and the conflict to be fairly and openly decided.

But to return:—By revealed, as distinguished from natural religion, we are to understand that knowledge of religion which was originally communicated in a supernatural way. A revelation

of this kind must either be by an *immediate* infallible inspiration, or illumination of every particular person, for informing and directing him with regard to the knowledge and practice of religion; or by God's making an extraordinary discovery of himself and of his will to some person or persons, who should be commissioned to communicate it to others. In the former case it could not be properly called extraordinary or supernatural revelation; for if it were a universal infallible light, imparted to every single person in every nation and every age, from the beginning of the world, it would be as common and familiar to every one as the common light of reason, and by being universal would cease to be extraordinary. Whereas, if there be such a thing as revealed religion, or if it has pleased God to make discoveries of his will to mankind with respect to religious truth and duty, in a way of extraordinary revelation, the most natural mode of doing it, and that which is best accommodated to the present state of mankind, seems to be that the revelation should be communicated to some person or persons, to be by them communicated to others in his name; at the same time furnishing them with sufficient proofs and credentials, to show that they were indeed sent and inspired by him, and that the doctrines and laws which are the matter of such revelation, and which they are authorised to publish to the world in his name, were really and originally communicated by revelation from him. This method admits of *sufficient proof* being given to satisfy well-disposed minds, and of provision being made for instructing men, unless it be their own fault, in the knowledge of religion, and engaging them to the practice of the duties which it requires; and at the same time there is room for the exercise of reason in examining the nature of the evidence, and the trial of men's sincerity and diligence, of their impartial love of truth, and their openness to receive it.

Two principal questions present themselves to our consideration with regard to this kind of revelation. Its usefulness and expediency, and even the necessity of it in the present state of mankind, and its proofs and evidences.

It is acknowledged by lord Bolingbroke, a writer of distinguished rank among the opposers of revelation (Works vol. ii. p. 468, ed. 4to.), 'that an extraordinary action of God upon the human mind, which the word 'inspiration' is now used to denote, is not more inconceivable than the ordinary action of mind upon body, or body on mind;' and 'that it is impertinent to deny the existence of any phenomena, merely because we cannot account for it.' Moreover as God can, if he thinks proper, communicate his will to mankind, he can also do it in such a manner as to give to those to whom it is originally and immediately made a full and certain assurance of its being a true divine revelation. Besides, God can commission those to whom he has made an extraordinary revelation of his will to communicate to others what they have received from him; and can furnish them with such credentials of their divine mission as are sufficient to prove that he sent them, and that the

doctrines and laws which they deliver in his name were indeed received from God. He can also undoubtedly, if he thinks fit, enable such persons to perform the most wonderful works in his name, as a proof that he sent them; works of such a nature and so circumstanced as manifestly to transcend all human power, and bear the evident marks of a divine interposition. He can also endue them with supernatural gifts, and enable them to deliver express predictions of future contingent events, which no human sagacity could foresee, and which yet shall be accomplished in the proper season. See PROPHECY. It should also be further observed, upon this subject, that not only they who live in the age when the revelation was first published to the world may have such proofs of it as may be sufficient to convince them of its divine authority and original, but that it may be transmitted with such evidence to those who live in succeeding ages as may lay them under an obligation to receive and submit to it as a revelation from God. Although oral tradition is not a very sure conveyance, yet it is undeniable that writings may be transmitted with such a degree of evidence as to leave no room for reasonable doubt. Such is the fact with regard to the revelation contained in the holy scriptures; nor is it difficult to prove that we have greater evidence of the safe transmission of these sacred writings, without any general and material corruption and alteration, than we have concerning other books, the genuineness of which is universally acknowledged. To this kind of argument it can only be objected that moral evidence is uncertain, and historical human testimony fallible; but to the objection the reply is obvious, that this kind of evidence may be, and frequently is, so circumstanced, that the man would scarcely be thought in his senses who should seriously deny or doubt of it. It is by moral evidence, and the testimony of fallible men, capable of deceiving and of being deceived, that a man who has never been at Paris or Rome knows that there are such cities, and yet he can no more reasonably doubt of it than if he had seen them with his own eyes. It is by moral evidence that we have all our laws and records, and the assurance of any past facts.

The great subject of present consideration, the usefulness and advantage of divine revelation, and the necessity of it in the present state of mankind, for supporting and promoting the interests of religion and virtue in the world, may thus be stated:—Such a revelation will be of great use even with regard to those truths and principles which lie at the foundation of all piety, or are common to what is called natural and revealed religion. Such are the truths which relate to the excellent and unparalleled nature, the perfections and attributes of the one supreme God. A divine revelation may also be very useful in establishing the belief of the providence of God, and in communicating instruction to all those who allow that some kind of religious worship and homage should be rendered to him. What kind of worship will be most acceptable to the Supreme Being, and what rites are most proper to be used in his service? are questions

which unassisted reason cannot positively and with certainty determine. The doctrine of the immortality of the soul, and of a future state of retribution, is unquestionably of very great importance to mankind; and the natural and moral arguments to prove it have certainly great weight; but they are assailed by difficulties and objections which weaken the evidence, and may occasion suspicion and doubt, if natural reason be our only guide and umpire. Accordingly some of the most eminent ancient philosophers either denied this doctrine, or expressed themselves doubtfully concerning it. If then God himself should, by a well-attested revelation, assure us that death shall not put an utter end to our being; that the present life is only the first stage of our existence; that we shall be raised again from the dead; and that God will call all men to an account, and reward or punish them in a future state according to their behaviour in this; and should also signify to us the nature of those rewards and punishments, and the qualifications of the persons on whom they should be conferred or inflicted; this must needs be of high advantage, and tend to give us satisfaction in a point of considerable importance, for encouraging men in the practice of virtue, and delivering them from vice and wickedness. Moreover, we are led by the light of nature and reason to entertain some hope that God will show mercy to sinners upon their repentance and amendment; but how far this mercy shall extend, whether he will pardon sins of every kind, even the most heinous, frequently repeated, and long persisted in, merely upon repentance and amendment; and whether his pardon in this case will be only a mitigation or remission of the threatened penalty, without a full restitution to grace and favor, and how far he will reward an obedience attended with failures and defects:—these things might create anxious doubts and perplexities in all thoughtful minds; especially when it is further considered that reason leads us to regard God as just as well as merciful, a wise and righteous governor, who will therefore exercise his pardoning mercy in such a way as seemeth most fit to his rectoral wisdom, and will best answer the ends of moral government. A revelation from God satisfying mankind, and especially anxious penitents, with regard to these interesting questions, and assuring them by express promise, as well as by its representations of the placability of God, and of the provision which he has made for the pardon of repenting transgressors, in perfect consistency with all the attributes of his nature and laws of his government, must be a very great benefit to the world. The assistance promised and certified by revelation to those who use their own earnest endeavours in the performance of their duty must further evince its importance and utility. The benefits and uses of a divine revelation further extend to those laws and duties which we owe to God, our neighbours, and ourselves, and which are comprehended under the class of moral obligations. But though revelation is thus eminently useful, and even necessary, it is not designed to supersede the use of our own reason, or to render the exercise of it needless, but to

guide, improve, and perfect it. Revelation, so far from discarding or weakening any argument that can be justly brought from reason, in proof of any truths relating to religion or morality, adds to them the attestation of a divine authority or testimony, which is of great weight. This too gives us a farther degree of certainty with regard to those things which are in some degree discoverable by the light of reason, and also furnishes us with a sufficient ground of assent with respect to those things which mere unassisted reason, if left to itself, would not have discovered, and which yet it may be of the highest importance for us to know.

This leads us to the next subject of enquiry proposed:—What are the proofs and evidences by which it may be known that such a revelation has been actually communicated to mankind? In general we may observe that it has been the sense of mankind, in all ages and nations, that God has made a revelation of his will to man; and this prevalent opinion has been probably derived from a tradition of some extraordinary revelation or revelations, communicated in the earliest times to the first ancestors of the human race, though in process of time it has been in a great measure corrupted and lost: or at least we may hence conclude that men have generally thought that a revelation from God to man was both possible and probable; and that this was agreeable to the ideas they had formed of the wisdom and goodness of God, and of his concern for mankind. It would lead us far beyond our present limits particularly to state the proofs that have been alleged for the divine authority of the Jewish and Christian revelation; both of which refer to and confirm the original revelation made to mankind. See the article THEOLOGY.

Of the Christian revelation, however, we may here remark, cursorily, that it is founded on a part of the Jewish, and has been opposed by the Jewish race: that is, the Messiah promised in the one revelation is declared to have come in the other. All the rest of the Jewish revelation, or that which related peculiarly to the Jewish people, is set aside; and only that part of it in which the world in general was interested, and that relating to the advent, offices, and character of the Messiah, are retained. It must be owned indeed that the Jews ever looked on this to be as peculiar to themselves as any of the rest: the Messiah was promised to them; he was to be their deliverer, their restorer, &c., and under this character he actually appeared. But, upon this new revelation taking place, a new scene was opened, different from what many of them apprehended, because they misinterpreted the prophecies relating to the Messiah. The ceremonial part of their institution, local and temporary in its establishment and use, was abolished; and the Messiah appeared, not as they erroneously imagined, to be the restorer of their civil sovereignty and liberties, which were now fallen into the hands of the Romans, but to restore and re-establish mankind in general, who had lost their original righteousness, and were become slaves of sin; to preach repentance and remission; and at last to suffer death, that all

who believed in him might not perish, but have everlasting life.

Now here it must be remembered that the Jewish infidel *quoad* Christianity establishes and advocates our faith in the old and more ancient scriptures. Between us and him, our most inveterate opponent, as to the evidences of Christianity, there is no difference, either as to the authenticity or inspiration of the greater part of our holy books. It is at most only a difference of interpretation. While the expansive character of the Christian dispensation opens it to new and far more comprehensive and irresistible arguments from reason and the general benevolence of providence.

REVELATION OF ST. JOHN. See APOCALYPSE.

REVEL, or Kolyvan, a town of European Russia, the capital of Esthonia, is situated on a small bay of the gulf of Finland, and has an excellent harbour, defended by the works of the town, and by batteries on some islands at its mouth. The town is further fortified by a mound and ditch, as well as by a citadel on a rock, and divided into three parts, called the town, suburb, and Domberg. The houses are of brick, and tolerably well built; but the streets are narrow and irregular. Of the churches, thirteen in number, six are for the Greek faith, and the others for the Lutheran. These churches, and several of the other ancient edifices, bear Danish inscriptions and coats of arms. Here is a military academy, a public library, and several schools, infirmaries, and poor houses. A small palace adjacent to the shore has gardens open to the public.

The population, about 13,000, are descended from German and Russian settlers, Swedes, Finns, and Esthonians. The average number of merchantmen that arrive in a year is about 200. The exports are corn, timber, hemp, and spirituous liquors from the interior. The imports bay salt, sugar, coffee, and British manufactures. Some glass and leather are made on the spot. Revel was founded by the Danes in 1218, conquered at a subsequent date by the Swedes, and taken from the latter, in 1710, by the Russians. It is 200 miles west of St. Petersburg, and 180 west by north of Riga.

REVELLO, a town of Piedmont, situated on a mountain, and fortified both by nature and art. It contains 5000 inhabitants, and has several well built churches, a palace and an old ruined castle. Nine miles north-west of Saluzzo.

REVENGE, *n. s.* } Fr. *revenger*, *revenger*  
 REVEN'GER, } *cher*; Span. *venger*:  
 REVENGEFUL, *adj.* } Ital. *vindicare*, of Lat.  
 REVENGEFULLY, *adv.* } *vindico*. To return  
 REVENGE'MENT, *n. s.* } or recompense an in-  
 REVEN'GINGLY, *adv.* } jury; wreak one's  
 wrongs on the wrong doer: the passion of vengeance; return of an injury. Dr. Johnson suggests a correct rather than an established distinction when he says, 'revenge is an act of passion: vengeance of justice. Injuries are revenged; crimes are avenged.' A revenger is, a vindictive person; one who wreaks vengeance: revengeful, vindictive; malicious: the adverb corresponding: revengement, an old synonyme of revenge, *non* substantive: revengingly, vindictively.

I will make mine arrows drunk with blood; from the beginning of *revenges* upon the enemy.

*Deut.* xxxiii. 42.

O Lord, visit me, and *revenge me* of my persecutors.

*Jeremiah.*

Edom hath *revenged himself* upon Judah.

*Ezekiel* xxv. 12

Who shall come to stand against thee, to be *revenged* for the unrighteous men? *Wisdom* xii. 12.

So shall the great *revenger* ruinate

Him and his issue by a dreadful fate. *Sandys.*

They often tread destruction's horrid path, And drink the dregs of the *revenger's* wrath. *Id.*

May be, that better reason will assuage The rash *revenger's* heat; words well disposed Have secret power to appease inflamed rage.

*Spenser.*

It may dwell

In her son's flesh to mind *revengement*, And be for all chaste dames an endless monument.

*Id.*

Come, Antony and young Octavius, *Revenge yourselves* alone on Cassius. *Shakspeare.*

It is a quarrel most unnatural,

To be *revenged* on him that loveth thee. *Id.*

*Revenges* burn in them; for their dear causes

Would to the bleeding and the grim alarm, Excite the mortified man. *Id. Macbeth.*

May my hands

Never brandish more *revengeful* steel Over the glittering helmet of my foe. *Shakspeare.*

I do not know,

Wherefore my father should *revengers* want, Having a son and friends. *Id.*

I've belied a lady,

The princess of this country; and the air on't *Revengingly* enfeebles me. *Id. Cymbeline.*

By the perclose of the same verse, vagabond is understood for such a one as travelleth in fear of *revengement*. *Raleigh.*

Deformed persons are commonly even with nature; for, as nature has done ill by them, so they do by nature; being void of natural affection, they have their *revenge* of nature. *Bacon.*

What had this been but to thrust themselves into the hands of the *revenger* of all wicked insolencies.

*Bp. Hall.*

Moses will not *revenge* this wrong, God will; yet will he not deal with them himself, but he sends the fiery serpents to answer for him. *Id.*

Into my borders now Jarbas falls, And my *revengeful* brother scales the walls.

*Denham.*

What will not ambition and *revenge* descend to? *Milton.*

Morocco's monarch

Had come in person, to have seen and known The injured world's *revenger* and his own. *Waller.*

If our hard fortune no compassion draws, The gods are just, and will *revenge* our cause.

*Dryden.*

Your fury of a wife,

Not yet content to be *revenged* on you, The' agents of your passion will pursue. *Id.*

The satyr in a rage

Forgets his business is to laugh and bite, And will of death and dire *revenges* write. *Id.*

Repenting England, this *revengeful* day,

To Philip's manes did an offering bring; He smiled *revengefully*, and leaped

Upon the floor: thence gazing at the skies, His eye-balls fiery red, and glowing vengeance; Gods, I accuse you not. *Id. and Lee's Oedipus.*

What government can be imagined without judicial proceedings? and what methods of judicature

without a religious oath, which supposes an omniscient being, as conscious to its falsehood or truth, and a *revenger* of perjury? *Bentley.*

Not unappeased, he passed the Stygian gate, Who leaves a brother to *revenge* his fate. *Pope.*

Draco, the Athenian lawgiver, granted an impunity to any person that took *revenge* upon an adulterer. *Broom.*

REVENUE, *n. s.* Fr. *revenu*; Lat. *reventus*. Income; annual profits.

They privily send over unto them the *revenues* wherewith they are there maintained. *Spenser.*

She bears a duke's *revenues* on her back, And in her heart scorns our poverty. *Shakspeare.*

Only I retain

The name and all the' addition to a king; The sway, *revenue*, beloved sons, be yours. *Id.*

Many offices are of so small *revenue*, as not to furnish a man with what is sufficient for the support of his life. *Temple.*

If the woman could have been contented with golden eggs, she might have kept that *revenue* on still. *L'Estrange.*

His vassals easy, and the owner blest,

They pay a trifle and enjoy the rest:

Not so a nation's *revenues* are paid;

The servant's faults are on the master laid. *Swift.*

When men grow great from their *revenue* spent, And fly from bailiffs into parliament. *Young.*

REVENUE, in law, is properly the yearly rent which accrues to any man from his lands and possession; but is generally used for the revenues or profits of the crown.

The fiscal prerogatives of the king, or such as regard his revenue, that is, those which the constitution has vested in the royal person, in order to support his dignity and maintain his power, are very learnedly treated of by Blackstone, in the eighth chapter of the first volume of his Commentaries. It will be sufficient to observe here that almost the whole of these were, in the late king's reign, consolidated and taken as the property of the country: his late majesty, soon after his accession, having accepted the limited sum of £800,000 per annum for the support of his civil list (charged also with three life-annuities, to the princess of Wales, the duke of Cumberland, and the princess Amelia, to the amount of £77,000), the hereditary and other revenues being made a part of the aggregate fund, which was charged with the payment of the whole annuity to the crown. The expenses formerly defrayed by the civil list were those that in any shape relate to civil government: as the expenses of the household; all salaries to officers of state, to the judges, and each of the king's servants; the appointments to foreign ambassadors; the maintenance of the queen and royal family; the king's private expenses, or privy purse; and other very numerous outgoings, as secret service money, pensions, and other bounties; which sometimes have so far exceeded the revenues appointed for that purpose that application has been made to parliament to discharge the debts contracted on the civil list; as particularly in 1724, when 1,000,000 was granted for that purpose by the statute 11 Geo. I. c. 17; and in 1769 and 1777, when 1,500,000 and £600,000 were appropriated to the like use, by the statutes 9 Geo. III. c. 34, and 17 Geo. III. c. 47. Many of these expenses are now charged on the

consolidated fund, and the civil list comprehends the support of his majesty's household. The civil list is, indeed, properly the whole of the king's revenue in his own distinct capacity; the rest being rather the revenue of the public, or its creditors, though collected and distributed again in the name and by the officers of the crown. See ENGLAND.

REVENUE, in hunting, a fleshy lump formed chiefly by a cluster of whitish worms on the head of the deer, supposed to occasion the casting of their horns by gnawing them at the root.

REVERB', *v. a.*  
 REVERBERANT, *adj.*  
 REVERBERATE, *v. a. & v. n.*  
 REVERBERATION, *n. s.*  
 REVERBERATORY, *adj.*

Fr. *reverberer*;  
 Latin *reverbero*.  
 To resound; beat  
 back: reverberate  
 is the more usual  
 verb, and signifies also to heat so that the flame  
 is reverberated upon the matter to be melted or  
 cleaned: reverberation is the act of beating or  
 driving back: reverberatory, driving back.

Reserve thy state, with better judgment check  
 This hideous rashness:  
 The youngest daughter does not love thee least;  
 Nor are those empty hearted whose loud sound  
 Reverbs no hollowness. *Shakspeare. King Lear.*  
 Hollow your name to the reverberate hills,  
 And make the babbling gossip of the air  
 Cry out Olivia. *Id. Twelfth Night.*

## Start

And echo with the clamour of thy drum,  
 And even at hand a drum is ready braced,  
 That shall reverberate all as well as thine.

*Shakspeare.*

As the sight of the eye is like a glass, so is the ear  
 a sinuous cave, with a hard bone, to stop and reverberate  
 the sound. *Bacon.*

To the reflection of visibles small glasses suffice;  
 but to the reverberation of audibles are required  
 greater spaces. *Id.*

The rays of royal majesty reverberated so strongly  
 upon Villerio that they dispelled all clouds.

*Hovel.*

Crocus martis, that is, steel corroded with vinegar  
 or sulphur, and after reverberated with fire, the loadstone  
 will not attract. *Broune.*

Good lime may be made of all kinds of flints, but  
 they are hard to burn, except in a reverberatory kiln.

*Moxon.*

The first repetitions follow very thick; for two  
 parallel walls beat the sound back on each other,  
 like the several reverberations of the same image from  
 two opposite looking-glasses. *Addison.*

As we, to improve the nobler kinds of fruits, are  
 at the expence of walls to receive and reverberate the  
 faint rays of the sun, so we, by the help of a good  
 soil, equal the production of warmer countries.

*Swift.*

REVERBERATORY FURNACE. See CHEMISTRY  
 and LABORATORY.

REVERE', *v. a.*  
 REVERENCE, *n. s. & v. a.*  
 REVERENCER, *n. s.*  
 REVEREND, *adj.*  
 REVERENT,  
 REVERENTIAL,  
 REVERENTIALLY, *adv.*  
 REVERENTLY,  
 REVERER, *n. s.*

Fr. *reverer*; Lat.  
*revereor*. To venerate;  
 regard with honor or awe:  
 reverence is, veneration;  
 respect; act of courtesy  
 or obeisance, bow: a title  
 that has been given both  
 to the clergy and to fathers:  
 to reverence seems

synonymous with to revere: a reverencer, or reverer, one who feels or manifests reverence: reverend is, venerable; deserving or commanding respect; an honorary epithet of the clergy: reverent is, humble; testifying reverence or submission: reverential, proceeding from, or expressive of, reverence: the adverbs corresponding.

And afterward we hadden fadres of our fleische techeris, and we with reverence dreden hem.

*Wiclif. Ebrewis xii.*

Onias, who had been high priest, reverend in conversation, and gentle in condition, prayed for the Jews. *2 Mac. xv. 12.*

Now lies he there,

And none so poor to do him reverence. *Shakspeare.*

Many now in health

Shall drop their blood, in approbation

Of what your reverence shall incite us to. *Id.*

O my dear father! let this kiss

Repair those violent harms that my two sisters

Have in thy reverence made. *Id.*

Those that I reverence, those I fear, the wise;

At fools I laugh, not fear them. *Id.*

Reverend and gracious senators. *Id.*

Chide him for faults, and do it reverently. *Id.*

All this was ordered by the good discretion

Of the right reverend cardinal of York.

*Id. Henry VIII.*

When quarrels and factions are carried openly it  
 is a sign the reverence of government is lost.

*Bacon's Essays.*

His disciples here,

By their great master sent to preach him every where,

Most reverently received. *Drayton.*

That oaths made in reverential fear

Of love and his wrath may any forswear. *Donne.*

He led her easily forth,

Where Godfrey sat among his lords and peers;

She reverence did, then blushed as one dismayed.

*Fairfax.*

In your prayers use reverent postures, and the  
 lowest gestures of humility, remembering that we  
 speak to God, in our reverence to whom we cannot  
 exceed. *Taylor.*

Higher of the genial bed,

And with mysterious reverence I deem. *Milton.*

While they pervert pure nature's healthful rules

To loathsome sickness, worthily since they

God's image did not reverence in themselves. *Id.*

A reverend sire among them came,

Who preached conversion and repentance. *Id.*

They forthwith to the place

Repairing, where he judged them, prostrate fell

Before him reverent. *Id. Paradise Lost.*

The Jews, reverentially declining the situation of  
 their temple, place their beds from north to south.

*Broune.*

To nearest ports their shattered ships repair,

Where by our dreadful cannon they lay awed;

So reverently men quit the open air,

When thunder speaks the angry gods abroad.

*Dryden.*

A poet cannot have too great a reverence for  
 readers. *Id.*

Upstarts the beldam,

And reverence made, accosted thus the queen. *Id.*

A parish priest was of the pilgrim train,

An awful, reverend, and religious man,

His eyes diffused a venerable grace,

And charity itself was in his face. *Id.*

The least degree of contempt weakens religion; it  
 properly consisting in a reverential esteem of things  
 sacred. *South*

When the divine revelations were committed to writing, the Jews were such scrupulous *reverers* of them that it was the business of the Masorites, to number not only the sections and lines, but even the words and letters of the Old Testament.

*Government of the Tongue.*

An emperor often stamped on his coins the face or ornaments of his colleague, and we may suppose Lucius Verus would omit no opportunity of doing honour to Marcus Aurelius, whom he rather *reversed* as his father, than treated as his partner in the empire.

*Addison's Remarks on Italy.*

Then down with all thy boasted volumes, down ;  
Only reserve the sacred one :

Low, *reverently* low,

Make thy stubborn knowledge bow :

To look to heav'n be blind to all below.

*Prior.*

Jove shall again *reverse* your power,

And rise a swan, or fall a shower. *Id.*

The reason of the institution being forgot, the after-ages perverted it, supposing only a *reverential* gratitude paid to the earth as the common parent.

*Woodward's Natural History.*

The fear acceptable to God is a filial fear ; an awful *reverence* of the divine nature, proceeding from a just esteem of his perfections, which produces in us an inclination to his service, and an unwillingness to offend him.

*Rogers.*

Rev'-end old man ! lo here confest he stands.

*Pope.*

Meet then the senior, far renowned for sense.

With *rev'rent* awe, but decent confidence.

*Id.*

All look up, with *reverential* awe,

At crimes that 'scape, or triumph o'er the law. *Id.*

The Athenians, quite sunk in their affairs, had little commerce with the rest of Greece, and were become great *reverencers* of crowned heads.

*Swift.*

He presents every one so often before God in his prayers that he never thinks he can esteem, *reverence*, or serve those enough, for whom he implores so many mercies of God.

*Law.*

With deep-struck *reverential* awe,

The learned sire and son I saw,

To Nature's God and Nature's law

They gave their lore,

This all its source and end to draw,

That to adore. *Burns.*

That had been just replied the *reverend* bard,

But done, fair youth, thou ne'er hadst met me here,

I ne'er had seen yon glorious throne in peace.

*Pollok.*

REVERSE', *v. a., v. n.,* Latin *reversus.*

REVER'SAL, *n. s.* [*& n. s.*] To turn complete-

REVER'SIBLE, *adj.* ly over, or upside

REVER'SION, *n. s.* down ; turn back ;

REVER'SIONARY, *adj.* put one thing in

the place of another ; subvert ; hence to contradict ; repeal ; turn to the contrary ; recal ; re-new (obsolete) : as a verb neuter, to return : as a noun-substantive, change ; vicissitude ; an opposite ; that side of a coin on which the head is not placed : reversible is, capable of being reversed or changed : reversion, right of succession ; state of being to be possessed after the death of a present possessor : the adjective corresponding.

Well knowing true all he did rehearse,

And to his fresh remembrance did *reverse*

The ugly view of his deformed crimes. *Spenser.*

Better it was, in the eye of his understanding, that sometimes an erroneous sentence definitive should prevail, till the same authority, perceiving such oversight, might afterwards correct or *reverse* it,

VOL. XVIII.

than that strifes should have respite to grow, and not come speedily unto some end. *Hooker's Preface.*

As were our England in *reversion* his,  
And he our subjects next degree in hope.

*Shakspeare.*

The king, in the *reversal* of the attainders of his partakers, had his will.

*Bacon's Henry VII.*

As the Romans set down the image and inscription of the consul, afterward of the emperor, on the one side, so they changed the *reverse* always upon new events.

*Camden.*

A decree was made that they had forfeited their liberties ; and albeit they made great moans, yet could they not procure this sentence to be *reversed*.

*Hayward.*

A life in *reversion* is not half so valuable as that which may at present be entered on.

*Hammond.*

He was very old, and had out-lived most of his friends ; many persons of quality being dead who had for recompence of services, procured the *reversions* of his office.

*Clarendon.*

Michael's sword staid not ;

But with swift wheel *reverse*, deep ent'ring shared  
Satan's right side.

*Milton.*

Our guard upon the royal side ;

On the *reverse* our beauty's pride.

*Waller.*

A pyramid *reversed* may stand upon his point, if balanced by admirable skill.

*Temple's Miscellanies.*

The strange *reverse* of fate you see ;

I pitied you, now you may pity me.

*Dryden.*

So many candidates there stand for wit,

A place at court is scarce so hard to get ;

In vain they crowd each other at the door ;

For ev'n *reversions* are all begg'd before.

*Id.*

Those seem to do best, who, taking useful hints from facts, carry them in their minds to be judged of, by what they shall find in history to confirm or *reverse* these imperfect observations.

*Locke.*

Though grace may have *reversed* the condemning sentence, and sealed the sinner's pardon before God, yet it may have left no transcript of that pardon in the sinner's breast.

*South.*

Count Tariff appeared the *reverse* of Goodman Fact.

*Addison.*

Several *reverses* are owned to be the representations of antique figures.

*Id. on Ancient Medals.*

With what tyranny custom governs men ! it makes that reputable in one age, which was a vice in another, and *reverses* even the distinctions of good and evil.

*Rogers.*

There are multitudes of *reversionary* patents and *reversionary* promises of preferments.

*Arbuthnot.*

These now controul a wretched people's fate ;

These can divide, and these *reverse* the state.

*Pope.*

Fame's a *reversion* in which men take place,

O late *reversion* ! at their own decease.

*Young.*

By a strange *reverse* of things, Justinian's law, which for many ages was neglected, does now obtain, and the Theodocian code is in a manner antiquated.

*Baker.*

Whoever feels pain in hearing a good character of his neighbour will feel a pleasure in the *reverse*. And those who despair to rise in distinction by their virtues are happy if others can be depressed to a level with themselves.

*Franklin.*

REVERSAL OF JUDGMENT, in law. A judgment may be falsified, reversed, or voided, in the first place, without a writ of error, for matters foreign to or dehors the record, that is, not apparent upon the face of it ; so that they cannot be assigned for error in the superior court, which can only judge from what appears in the record itself ; and therefore, if the whole record be not certified, or not truly certified, by the inferior

2 O

court, the party injured thereby in both civil and criminal cases may allege a diminution of the record, and cause it to be rectified. 2dly, A judgment may be reversed by writ of error, which lies from all inferior criminal jurisdictions to the court of king's bench, and from the king's bench to the house of peers, and may be brought for notorious mistakes in the judgment or other parts of the record. The effect of falsifying or reversing an outlawry is, that the party shall be in the same plight as if he had appeared upon the *capias*: and, if it be before pleaded, he shall be put to plead to the indictment; if, after conviction, he shall receive the sentence of the law; for all the other proceedings, except only the process of outlawry for his non-appearance, remain good and effectual as before. But, when judgment pronounced upon conviction is falsified or reversed, all former proceedings are absolutely set aside, and the party stands as if he had never been at all accused, restored in his credit, his capacity, his blood, and his estates; with regard to which last, though they be granted away by the crown, yet the owner may enter upon the grantee, with as little ceremony as he might enter upon a disseisor. But he still remains liable to another prosecution for the same offence: for, the first being erroneous, he never was in jeopardy thereby.

REVERSION, in the law of England, has two significations: the one of which is an estate left, which continues during a particular estate in being; and the other is the returning of the land, &c., after the particular estate is ended; and it is further said to be an interest in lands, when the possession of it fails, or where the estate which was for a time parted with returns to the granters, or their heirs. But, according to the usual definition of a reversion, it is the residue of an estate left in the grantor, after a particular estate granted away ceases, continuing in the grantor of such an estate. The difference between a remainder and a reversion consists in this, that the remainder may belong to any man except the grantor; whereas the reversion returns to him who conveyed the lands, &c.

REVERT, *v. a., v. n., & n. s.* Lat. *revertor*. To change; turn to the contrary; reverberate; return; fall back: as a musical term, recurrence; reverte; returnable.

My arrows,  
Too slightly timbered for so loud a wind,  
Would have *reverted* to my bow again.

*Shakespeare.*

If his tenant and patentee should dispose of his gift, without his kingly assent, the lands shall *revert* to the king.

*Bacon.*

Hath not musick her figures the same with rhetoric? what is a *revert* but her antistrophe?

*Peachment on Muzick.*

Wretched her subjects, gloomy sits the queen,  
Till happy chance *revert* the cruel scene;  
And apish folly, with her wild resort  
Of wit and jest, disturbs the solemn court.

*Prior.*

The stream boils

Around the stone, or from the hollowed bank  
*Reverted* plays in undulating flow.

*Thomson.*

REVERIE, or } French *reverie*. Loose  
REVERY, *n. s.* } musing; irregular thought.

*Revery* is when ideas float in our mind, without any reflection or regard of the understanding.

*Locke.*

If the minds of men were laid open, we should see but little difference between that of the wise man and that of the fool; there are infinite *reveries* and numberless extravagancies pass through both.

*Addison.*

I am really so far gone as to take pleasure in *reveries* of this kind.

*Pope.*

REVEST, *v. a.* Fr. *revestir. revêtir*; Lat. *revestio*. To clothe again.

Her nathless,

The' enchanter finding fit for his intents,  
Did thus *revest*, and deckt with due habiliments.

*Spenser.*

The effectual power of words the Pythagoreans extolled; the impious Jews ascribed all miracles to a name, which was engraved in the *revestiary* of the temple.

*Camden's Remains.*

When thou of life renewest the seeds,  
The withered fields *revest* their cheerful weeds.

*Walton.*

REVICTION, *n. s.* Lat. *revictum*. Return to life.

If the Rabines' prophecy succeed, we shall conclude the days of the phenix, not in its own, but in the last and general flames, without all hope of *reviction*.

*Brown.*

REVICTUAL, *v. a.* Re and victual. To stock anew with victuals.

It hath been objected, that I put into Ireland, and spent much time there, taking care to *revictual* myself, and none of the rest.

*Ruleigh's Apology.*

REVIEW, *v. a. & n. s.* } Re and view. To  
REVIEWER, *n. s.* } look back; see or consider again; retrace; in modern literature to give a public character of a book after having examined it more or less: the noun substantive corresponding.

I shall *review* Sicilia; for whose sight

I have a woman's longing.

*Shakespeare.*

So swift he flies, that his *reviewing* eye  
Has lost the chasers, and his ears the cry.

*Denham.*

He with great indifference considered his *reviews* and subsequent editions.

*Fell.*

Segrais says, that the *Æneis* is an imperfect work, and that death prevented the divine poet from *reviewing* it; and, for that reason he had condemned it to the fire.

*Dryden.*

We make a general *review* of the whole work, and a general *review* of nature; that, by comparing them, their full correspondency may appear.

*Burnet's Theory of the Earth.*

The works of nature will bear a thousand *views* and *reviews*; the more narrowly we look into them, the more occasion we shall have to admire.

*Atterbury's Sermons.*

Shall I the long laborious scene *review*,

And open all the wounds of Greece anew.

*Pope.*

I did not suspect, till the *reviewers* told me so, that you are made up of artifice and design, and that your ambition is to delude your hearers.

*Couper's Private Correspondence.*

REVIEW, in military affairs, is the drawing out all or part of the army in line of battle, to be viewed by the king, or a general, that they may know the condition of the troops.

**REVIEW, COMMISSION OF**, is a commission sometimes granted in extraordinary cases, to revise the sentence of the court of delegates, when it is apprehended they have been led into a material error. This commission the king may grant, although the statutes 24 and 25, Henry VIII., declare the sentence of the delegates definitive: because the pope, as supreme head by the canon law, used to grant such commission of review; and such authority as the pope heretofore exerted is now annexed to the crown, by statutes 26 Henry VIII. c. 1, and Eliz. c. 1. But it is not matter of right, which the subject may demand *ex debito justitiæ*; but merely a matter of favor, and which therefore is often denied.

**REVILE**, *v. a. & n. s.* } Re and vile. To  
**REVIL'ER**, } reproach; vilify: the  
**REVIL'INGLY**, *adv.* } reproach given: the  
other noun substantive and the adverb corresponding.

Fear not the reproach of men, neither be afraid of their *revilings*. *Isaiah li. 7.*

Asked for their pass by every squire,  
That list at will them to *revile* or snib. *Spenser.*  
I read in 's looks

Matter against me; and his eye *reviled*  
Me as his abject object. *Shakspeare. Henry VIII.*

I heard thee in the garden, and of thy voice  
Afraid, being naked, hid myself,—to whom  
The gracious Judge, without *revile*, replied. *Milton.*

The bitterest *revilers* are often half-witted people.  
*Government of the Tongue.*

She still beareth him an invincible hatred, *revileth*  
him to his face, and railleth at him in all companies.  
*Swift.*

**REVILLA GIGEDO**, a large island on the coast of north-west America, first circumnavigated by Vancouver, and so called in honor of Conde de Revilla Gigedo, viceroy of New Spain. It is about fifty miles in length, and twenty-five in breadth. Here Vancouver was, before he was aware, surrounded by the natives in their canoes, and in imminent danger of being murdered. After various fruitless efforts to conciliate the inhabitants, he at length gave the order to fire, when they all immediately fled, but two British sailors were badly wounded with spears. Long. 228° 27' to 229° 15' E., lat. 55° 6' to 55° 55' N.

**REVILLA GIGEDO, CANAL DE**, a channel on the north-west coast of North America, so called by Vancouver, and formed by the island of Revilla Gigedo on the west, and by the continental shore of North America and the island of Gravina on the east.

**REVISE**, *v. a. & n. s.* } Lat. *revisus*. To  
**REVIS'AL**, *n. s.* } review; overlook: a  
**REVIS'ION**. } review or re-examination: this is also the general sense of *revisal*: revision is the act of revising.

His sending them sheet by sheet when printed, and surveying the *revises*. *Fell.*

The *revisal* of these letters has been a kind of examination of conscience to me; so fairly and faithfully have I set down in them the undisguised state of the mind. *Pope.*

Lintot, dull rogue! will think your price too much:

Not, Sir, if you *revise* it, and retouch.' *Id.*

**REVISIT**, *v. a.* Fr. *revisiter*; Lat. *revisto* *revisito*. To visit again.

Thee I *revisit* safe,  
And feel thy sovereign vital lamp; but thou  
*Re-visitest* not these eyes, that rowl in vain,  
To find thy piercing ray, and find no dawn.

*Milton.*  
Let the pale sire *revisit* Thebes, and bear  
These pleasing orders to the tyrant's ear. *Pope.*

**REVIVE**, *v. n. & v. a.* } Fr. *revivre*; Lat.  
**REVIV'ER**, *n. s.* } *revivo, re* and *vivifico*  
**REVIV'IFICATE**, *v. a.* } To return to life, vi-  
**REVIVIFICATION**, *n. s.* } gor, or activity; to  
**REVIVIS'ENCY**. } renew; to quicken;  
rouse: to *revivificate* is to call to life: *revivifica-*  
*tion*, the act of doing so: *reviviscency*, renewal  
of life.

The Lord heard Elijah, and the soul of the child  
came unto him again, and he *revived*.  
*1 Kings xvii. 22.*

God lighten our eyes, and give us a little *reviving*  
in our bondage. *Exra ix. 8.*

Noise of arms, or view of martial guise,  
Might not *revive* desire of knightly exercise.

*Spenser.*  
I should *revive* the soldiers' hearts;  
Because I ever found them as myself. *Shakspeare.*

So he dies;  
But soon *revives*: death over him no power  
Shall long usurp. *Milton.*

I *revive*  
At this last sight, assured that man shall live. *Id.*

What first *Æneas* in this place beheld  
*Revived* his courage, and his fear expelled. *Dryden.*

The memory is the power to *revive* again in our  
minds those ideas which after imprinting have been  
laid aside out of sight. *Locke.*

As long as an infant is in the womb of its parent,  
so long are these medicines of *revivification* in pre-  
paring. *Spectator.*

Scripture makes mention of a restitution and  
*reviviscency* of all things at the end of the world.  
*Burnet.*

He'll use me as he does my betters,  
Publish my life, my will, my letters,  
*Revive* the l'els born to die,  
Which Pope must bear as well as I. *Swift.*

**REUNITE**, *v. a.* } Re and unite. To join  
**REUN'ION**, *n. s.* } again; make one a second  
time; join what is divided: the noun substan-  
tive corresponding.

By this match the line of Charles the Great  
Was *reunited* to the crown of France. *Shakspeare.*

She, that should all parts to *reunion* bow,  
She that had all magnetick force alone,  
To draw and fasten sundry parts in one. *Donne.*

**REVOKE**, *v. a.* } Fr. *revoquer*; Span  
**REVO'CALE**, *adj.* } and Port. *revocar*;  
**REVO'CALENESS**, *n. s.* } Lat. *revoco*. To re-  
**REVOCA'TION**, } peal; reverse; re-  
**REVOKE'MENT**. } peal; draw back:

*revocable* is that which may be recalled or re-  
pealed: the noun substantive corresponding:  
*revocation*, the act of recalling, or state of being  
recalled; *repeal*: *revokement* (disused) is its  
synonyme.

What reason is there, but that those grants and  
privileges should be *revoked*, or reduced to the first  
intention? *Spenser.*

She strove their sudden rages to *revoke*,  
That at the last suppressing fury mad,  
They 'gan abstain. *Id.*

When we abrogate a law as being ill made, he



whole cause for which it was made still remaining, do we not herein *revoke* our very own deed, and upbraid ourselves with folly, yea all that were makers of it with oversight and error? *Hooker.*

One, that saw the people bent for the *revocation* of Calvin, gave him notice of their affection. *Id.*

Let it be noised,

That through our intercession, this *revokement* And pardon comes. *Shakspeare, Henry VIII.*

Howsoever you shew bitterness, do not act any thing that is not *revocable*. *Bacon's Essays.*

Seas are troubled, when they do *revoke* Their flowing waves into themselves again. *Davies.*  
A law may cease to be in force, without an express *revocation* of the lawgiver. *White.*

His successor, by order, nullifies Many his patents, and did *revoate* And re-assume his liberalities. *Daniel's Civil War.*  
Elaiana's king commanded Chenandra to tell him that he had received advice of his *revocation*.  
*Howel's Vocal Forest.*

Without my Aurengzebe I cannot live;

*Revoke* his doom, or else my sentence give.

*Dryden.*

If a grievance be inflicted on a person, he may appeal; it is not necessary to pray a *relocation* of such a grievance. *Ayliffe.*

**REVOLT**, *v. n.* } *Fr. revolter*; *Ital. revol-*  
**REVOLTER**, *n. s.* } *tare*; of *Lat. re* and *voluto*.  
To fall off from one to another; change: a desertion; rebellion: *Shakspeare* uses it for *revolter*.

This people hath a *revolting* and a rebellious heart; they are *revolted* and gone. *Jeremiah v. 53.*  
All will *revolt* from me, and turn to him.

*Shakspeare.*

You are already love's firm votary,  
And cannot soon *revolt* and change your mind. *Id.*

You ingrate *revolts*,

You bloody Neros, ripping up the womb

Of your dear mother England. *Id.*

Our daughter hath made a gross *revolt*. *Id.*

He was greatly strengthened, and the enemy as much enfeebled by daily *revolts*. *Raleigh.*

Thou single hast maintained

Against *revolted* multitudes the cause of truth.

*Milton.*

Fair honour that thou dost thy God, in trusting  
He will accept thee to defend his cause,  
A murderer, a *revolter*, and a robber. *Id.*

If all our levies are made in Scotland or Ireland, may not those two parts of the monarchy be too powerful for the rest, in case of a *revolt*?

*Addison's State of the War.*

He was not a *revolter* from the truth which he had once embraced. *Atterbury's Sermons.*

Those who are negligent or *revolters* shall perish.

*Swift.*

**REVOLVE**, *v. n. & v. a.* } *Lat. revolve.*

**REVOLUTION**, *n. s.* } To roll in a circle;  
fall back; roll any thing round; consider; meditate on: revolution is the act of revolving; course of, or space measured by, that which revolves; rotation; backward motion; change in the government of a country. Used among us particularly for the change produced by the admission of king William and queen Mary.

You may *revolve* what tales I told you

Of courts, of princes, of the tricks of war.

*Shakspeare.*

Then in the east her turn she shines,

*Revoluted* on heaven's great axis.

*Milton.*

On their orbs impose

Such restless *revolution*, day by day

Repeated.

*Id. Paradise Lost.*

**FEAR**

Comes thund'ring back with dreadful *revolution*

On my defenceless head.

*Milton.*

Meteors have no more time allowed them for their mounting, than the short *revolution* of a day.

*Dryden.*

The late *revolution*, justified by its necessity, and the good it had produced, will be a lasting answer.

*Davenant.*

On the desertion of an appeal, the jurisdiction does ipso jure *revolve* to the judge a quo.

*Ayliffe's Parergon.*

The Persian wept over his army, that within the *revolution* of a single age, not a man would be left alive.

*Waks.*

They do not *revolve* about any common centre.

*Cheyne.*

Each *revolving* year,

The teeming ewes a triple offspring bear. *Pope.*

If the earth *revolve* thus, each house near the equator must move a thousand miles an hour.

*Watts's Improvement of the Mind.*

They will be taught: the diurnal *revolution* of the heavens.

*Watts.*

Winds of the north! restrain your icy gales,  
Nor chill the bosom of these happy vales!

Hence in dark heaps, ye gathering clouds, *revolve!*

Disperse, ye lightnings! and ye mists dissolve!

*Darwin.*

**REVOMIT**, *v. a.* *Fr. revomir.* Re and vomit. To vomit again.

They might cast it up, and take more, vomiting and *revomiting* what they drink. *Hakewell.*

**REUS**, a considerable town of Catalonia, Spain, situated in a fertile plain, six miles from the sea. The harbour is near a village called Salon, and is joined to the town by a canal. It is one of the two towns of Spain that have risen into importance in modern times. Manufactures of silk, cottons, leather, hats, brandy and liquors, have been progressively established; and the population now exceeds 20,000. Eight miles west from Tarragona.

**REUSS**, a principality of Upper Saxony, divided into two parts, of which the one adjoins Prussia, the other Bavaria. The area of the whole is about 600 square miles; general hilly, and better adapted for pasture than tillage. The hills are productive of copper and lead; also a few of iron, silver, alum, and vitriol. The more extensive manufactures are woollen and linen, the smaller cottons, leather, and hardware. The chief town is Gera. The north-east corner of this principality is watered by the Elster, the south-west by the Saale. The princes of Reuss are of an old family, repeatedly divided and subdivided. At present it consists of two principal lines, the elder and younger; the latter having an income of £40,000 sterling, the elder of about £13,000. They both have votes in the diet of the Germanic confederation; and there exists a deliberative body in this petty principality under the name of states. The prevailing religion is the Lutheran. Population 85,000.

**REUSS**, one of the largest rivers of Switzerland, issues from the lake Luzendro, in Mount St. Gotthard, and flows through the Waldstadtersee, passing by Lucerne, until it falls into the

**Aar, near Bruck.** It has a great number of waterfalls, and receives mountain streams in rapid succession. Below the valley of Urseren on this stream is the Devil's Bridge, consisting of a single arch, of eighty feet span, at a spot where the water has a fall of 100 feet. It abounds in fine salmon, and becomes navigable at Lucerne.

**REUTLINGEN,** an ancient town of Wirtemberg, Germany, on the river Echetz, nineteen miles south by east of Stutgard. After being long a free town, it was incorporated with the dominions of Wirtemberg and its population about 8000.

**REVULSION, n. s.** } Fr. *revulsion*; Lat. *REVULSIONARY, adj.* } *revulsus*. The act of drawing the blood or humors from remote parts of the body: having the power of revulsion.

There is a way of *revulsion* to let blood in an adverse part. *Bacon's Natural History.*

His flux of blood breaking forth again with greater violence than it had done before, was not to be stopped by outward applications, nor the *revulsives* of any kind. *Fell.*

I had heard of some strange cures of frenzies, by casual applications of fire to the lower parts, which seems reasonable enough, by the violent *revulsion* it may make of humours from the head. *Temple.*

Derivation differs from *revulsion* only in the measure of the distance, and the force of the medicines used: if we draw it to some very remote or contrary part, we call it *revulsion*; if only to some neighbouring place, and by gentle means, we call it derivation. *Wiseman of Tumours.*

**REWARD, v. a. & n. s.** } Re and award.—  
**REWARD'ABLE, adj.** } Skinner. To give  
**REWARD'ER, n. s.** } in return; repay; recompense; the recompense given; used sometimes, but not frequently, for a recompense of evil: rewardable is worthy of reward: rewarder, he who bestows recompense.

Thou hast rewarded me good, whereas I have rewarded thee evil. *1 Sam. xxiv. 17.*

They rewarded me evil for good. *Psal. xxv. 12.*

Rewards and punishments do always presuppose something willingly done well or ill; without which respect, though we may sometimes receive good, yet then it is only a benefit and not a reward. *Hooker.*

Men's actions are judged, whether in their own nature rewardable or punishable. *Id.*

A liberal rewarder of his friends. *Shakespeare.*

God rewards those that have made use of the single talent, that lowest proportion of grace which he is pleased to give; and the method of his rewarding is by giving them more grace. *Hammond.*

The action that is but indifferent, and without reward, if done only upon our own choice, is an act of religion, and rewardable by God, if done in obedience to our superiors. *Taylor.*

There is no more reason to reward a man for believing that four is more than three, than for being hungry or sleepy; because these things do not proceed from choice, but from natural necessity. A man must do so, nor can he do otherwise. *Wilkins.*

To judge th' unfaithful dead, but to reward His faithful, and receive them into bliss. *Milton.*

Men have consented to the immortality of the soul and the recompenses of another world, promising to themselves some rewards of virtue after this life. *Tillotson.*

To myself I owe this due regard,  
Not to make love my gift, but my reward. *Dryden.*

As the Supreme Being is the only proper judge of our perfections, so is he the only fit rewarder of them. *Addison.*

Ill judges, as well as rewarders, have popular assemblies been, of those who best deserved from them. *Swift.*

The Supreme Being rewards the just, and punishes the unjust. *Broome on the Odysey.*

**REWORD, v. a.** Re and word. To repeat in the same words.

Bring me to the test,  
And I the matter will reword; which madness  
Would gambol from. *Shakespeare. Hamlet.*

**REYES,** a city of the Caraccas, Colombia. The inhabitants carry on a lucrative trade in cacao, tobacco, and in neat cattle. Forty miles S. S. W. from Caraccas. It is also the name of several other settlements in South America.

**REYN (John de),** an eminent historical and portrait painter, born at Dunkirk in 1610. He was a disciple of Vandyke, and was so attached to his master that he followed him to London, where it is thought he continued as long as he lived. In Britain he is mostly known by the name of Lang Jan. He died in 1678. The scarcity of his works is said to be occasioned by so many of them being imputed to Vandyke.

**REYNEAU (Charles Rene),** a member of the French Academy, and an eminent mathematician, born at Bressac, in Anjou, in 1650. He taught philosophy at Toulon, and became professor of mathematics at Algiers, in 1683. He published a famous work, entitled *Analyses Demonstrated*, in which he reduced into a body the theories of Newton, Descartes, Leibnitz, &c. He died in 1722, aged seventy-two.

**REYNER (John),** a learned divine, born a Lincoln, and educated at Emanuel College, Cambridge, of which he was a fellow. He was ejected from his living for nonconformity in 1662; and died at Nottingham, where he had practised physic. His writings are chiefly theological.

**REYNOLDS (Sir Joshua),** an eminent English painter, born at Plympton, his father being master of the grammar school of that town. At an early age he evinced a fondness for drawing, which induced his father finally to place him at the age of seventeen with Hudson, then the first portrait painter in London. He remained with him only three years, and then upon some trifling disagreement returned into Devonshire. One of his first performances, at this period, was the picture of a boy reading by a reflected light, which was sold fifty years afterwards for thirty-five guineas. He now practised at Plymouth Dock, and, while there, obtained an introduction to the noble family of Mount Edgecumbe, and became acquainted with captain, afterwards admiral lord Keppel. That officer being about to sail in 1749, for the Mediterranean, offered to take Reynolds thither, which invitation he gladly accepted. While at Minorca he was much employed in painting portraits, by which means he increased his finances sufficiently to enable him to visit Rome, in which capital and in other parts of Italy he remained about three years. At the latter end of 1752 he returned to London, and the first specimen he then gave of his

improvements was the head of his pupil, Giuseppe Marchi, painted in a Turkish dress. The picture attracted so much notice that Hudson came to see it, and, after examining it for some time, he said, 'Reynolds, you don't paint so well as you did when you left England.' Notwithstanding this invidious remark, and the depreaved state of public taste, Reynolds quickly rose into high reputation as a portrait painter, and the whole length of his friend, commodore Keppel, gained him great popularity. Soon after this, he added to his celebrity, by his picture of Miss Greville and her brother, as Psyche and Cupid, executed in a style which had not been seen in England since the days of Vanduyck. He rapidly acquired opulence, and, being universally regarded as at the head of his profession, he kept a splendid table, which was frequented by the first company in the kingdom. In 1762 he produced his celebrated picture of Garrick between tragedy and comedy, for which the earl of Halifax paid 300 guineas. On the institution of the Royal Academy, in 1768, the presidentship was unanimously conferred on Reynolds, who, at the same time, received the honor of knighthood. Although it was no prescribed part of his duty to read lectures, yet his zeal for the advancement of the fine arts induced him to deliver annual or biennial discourses before the academy on the principles and practice of painting. Of these he pronounced fifteen, from 1769 to 1790, which were published in two sets, and form a standard work. In 1775 Sir Joshua Reynolds was chosen a member of the Imperial Academy at Florence, on which occasion he sent his portrait, drawn in his academical dress, to be placed in the gallery of painters in that city. In the summer of 1781, Sir Joshua, accompanied by a friend, made a tour in Holland and the Netherlands, chiefly with a view to examine the works of the celebrated masters of the Dutch and Flemish schools. Two years afterwards, on the suppression of some of the religious houses in the Low Countries, he again visited Flanders, where he purchased some pictures by Rubens. In 1784 he succeeded Allan Ramsay, as painter to the king, and, in the autumn of the next year, Sir Joshua again paid a visit to Flanders, to attend a sale of pictures collected from the dissolved monasteries; of which, particularly those of Rubens, he purchased many of great value. About the same time he was employed on a commission from the empress of Russia, to paint for her an historical picture, the subject of which being left to himself, he chose that of the infant Hercules strangling the serpents. In return for this piece, the empress sent him 1500 guineas, and a gold box, with her picture set in diamonds. He continued to follow his profession, of which he was enthusiastically fond, till in 1789 he lost the sight of one of his eyes. An unhappy difference soon after arose between him and the members of the Royal Academy, in consequence of which he resigned not only his presidentship but also his place as a member. He was afterwards however induced by the mediation of the king to resume his post. He was a distinguished member of the celebrated club which contained

the names of Johnson, Garrick, Burke, and others of the first rank of literary eminence, and seems to have been universally loved and respected by his associates. He was also a member of the London Antiquarian and Royal Societies, and of several other literary institutions abroad. In 1791 he partly lost the sight of his remaining eye, which exceedingly depressed him. He was not, however, a prey to lingering illness, being carried off by a disease in the liver in 1792, in his sixtieth year. He died unmarried, and was interred in St. Paul's cathedral. He formed a splendid collection of works of art, which, after his death, was sold for £16,947 7s. 6d., and the whole of his property amounted to about £80,000, the bulk of which he left to his niece, who married lord Inchiquin, afterwards marquis of Thomond. As a writer he obtained great credit by his Discourses, which are elegant and agreeable compositions, although sometimes vague and inconsistent. He also added notes to Dufresnoy's Art of Painting, and gave three papers on painting to the Idler. The whole of The Literary Works of Sir Joshua Reynolds were edited by Mr. Malone in 2 vols. 4to., 1797, with a Life of the Author.

REYS, POINT OF CAPE DE LOS, a conspicuous promontory on the west coast of North America, which from the north or south, at the distance of five or six leagues, appears insulated. Its highest part terminates in steep cliffs, nearly perpendicular to the sea, which ceats against them with great violence. Long. 237° 24' E., lat. 38° 36' N.

REZZONICO (Gaston Della Torre), count, was born at Parma, in 1740. He made early acquisitions in literature, was admitted a member of the academy of Arcadi, and was appointed by the duke of Parma president of a new academy of fine arts, which he had established. He was afterwards however deprived of his places; and he left Parma, and travelled through France, England, and other parts of Europe. He wrote several works both in prose and poetry, but the latter are most admired, and rank him among the best Italian poets. He died in Rome, in 1798. A collection of his poems was printed at Parma, in 2 vols.

RHABARBARATE, *adj.* Lat. *rhabarbara* Impregnated or tinctured with rhubarb.

The salt humours must be evacuated by the senate, *rhabarbarate* and sweet manna purgers, with acids added, or the purging waters. *Flower.*

RHABDOLOGY, or RABDOLOGY, in arithmetic, a name given by Napier to a method of performing some of the more difficult operations of that science by means of certain square rods. Upon these are inscribed the simple numbers; and by shifting them, according to certain rules, these operations are performed by simply adding or subtracting the numbers as they stand upon the rods. See Napier's Rhabdologia, printed in 1617. See also the article NAPIER'S RODS.

RHABDOMANCY, *n. s.* Greek, *ραβδος* and *μαντεια*. Divination by a wand.

Of peculiar *rhabdomancy* is that which is used in mineral discoveries, with a forked hazel, commonly

called Moses a rod, which, freely held forth, will stir and play if any mine be under it.

*Browne's Vulgar Errors.*

**RHADAMANTHUS**, in fabulous history, the son of Jupiter and Europa, born in Crete. He became king of Lydia, and reigned over the Cyclades, and several Greek cities of Asia, with so much justice and impartiality that the poets make him one of the three judges of hell. According to Plato, Æacus judged the Europeans; and Rhadamanthus, who had left Crete, and fixed his residence in Asia, the Asiatics, among whom were also comprehended the Africans. The stern Rhadamanthus superintends in Tartarus the execution of the sentences which his brother Minos pronounces, after shaking the fatal urn in which are contained the destinies of all mortals. His office is described by Virgil, *Æneid*, lib. iv:—

‘Gnosius hæc Rhadamanthus habet durissima regna  
Castigatque auditque dolos, subigitque fateri,  
Quæ quisque apud superos, furto lætatus inani  
Distulit in seram commissa piaculum mortem.’

**RHÆTI**, or **RÆTI**, an ancient warlike nation of Italy, in Etruria. They were driven from their country by the Gauls.

**RHÆTIA**, in ancient geography, a country in the north of Italy, between the Alps and the Danube. Its chief towns were Coria, Tridentum (now Trent), Belunum, and Feltria. It was divided into two parts, called Rhætia Prima, which extended from the sources of the Rhine to those of the Licus, a small river which runs into the Danube, and Rhætia Secunda, or Rhætia Vindelicia, which extended from the Licus to the Oenus, another small river towards the east. The ancient inhabitants of Rhætia rendered themselves formidable to the Romans, by their frequent invasions; but were at last conquered by Drusus the brother of Tiberius, and others under the succeeding emperors. *Strab.* iv. *Plin.* iii. c. 20.

**RHAMA**, or **RAMA**, an incarnate deity of the first rank, in the Hindoo mythology. Sir William Jones believes he was the son of Cush, grandson of Ham, and the first monarch in that part of Asia; and that he was the Dionysos of the Greeks, whom they named Bugenes, when they represented him horned, as well as Lyaos and Eleutherios the deliverer, and Triambos, or Dithyrambos, the triumphant. ‘Most of those titles,’ says Sir William, ‘were adopted by the Romans.’ The festival of Rhama is held on the ninth day of the new moon of Chaitra, on which the war of Lauca is dramatically represented, concluding with an exhibition of the fire ordeal by which the victor’s wife Sita gave proof of her connubial fidelity. There are three Rhamas mentioned in the Indian mythology, who are described as youths of perfect beauty. The third Rhama is the eighth Avatar. Like all the Avatars, Rhama is painted with gemmed Ethiopian or Parthian coronets; with rays encircling his head; jewels in his ears, two necklaces, one straight and one pendant on his bosom, with dropping gems; garlands of well-disposed many-colored flowers, or collars of pearl, hanging down below his waist, &c. It is Rama Chandra, and his lovely Sita, who are the favorite subjects of he-

roic and amatory poetry: he is described in the *Ramayana* as Rama ‘of ample shoulders; brawny arms, extending to the knee; neck shell-formed; chest circular and full, with auspicious marks; body hyacinthine; with eyes and lips of sanguine hue; the lord of the world; a moiety of Vishnu himself; the source of joy to Ikshwaku’s race.’ His faithful wife Sita is one of the most interesting females in Hindoo poetry. Rama is also called Raghava, or son of Raghu. Kaka-paksha-dara, or crow-winged, is an epithet given to the Ramas, and to other warriors, from a certain mode of shaving the head, leaving the hair over the ears only, resembling crow’s wings. Shyamula, or blue-bodied, is an appellation of Rama, as well as of Krishna, and of their common prototype, Vishnu; all being represented of hyacinthine hue. It may be here remarked, that several incidents in the *Sri-Bhagavat* (a history of Krishna), and in the *Ramayana*, told similarly of their several heroes, seem to mix or approximate, though perhaps scarcely to identify, the characters of Krishna and Rama. Each won a wife by bending an unyielding bow, a story not very unlike that of Ulysses. Each is described as overcoming the demon Kumbakarna, and others. Krishna descended into hell; so did Sita, the sakti, or energy of Rama.

**RHAMNUS**, in ancient geography, a town of Attica, famous for a temple of Amphiaras, and a statue of Nemesis, thence called Rhamnusia. This statue was made by Phidias, out of a block of fine Parian marble, which the Persians had brought to erect as a monument of their expected conquest of Greece. *Paus.* i. *Plin.* 36.

**RHAMNUS**, the buckthorn, in botany, a genus of the monogynia order and pentandria class of plants; natural order forty-third, *dumosæ*: *CAL.* tubulose, with five minute scales surrounding the stamina: *COR.* none: the fruit is a berry. There are thirty species; of which the most remarkable are,

1. *R. alaternus*, the common alaternus, is an evergreen, a native of the south of Europe. There are several varieties, the most remarkable are the broad-leaved and the jagged-leaved alaternus, which have all been confounded with the phillyrea.

2. *R. alpinus*, rough-leaved frangula, or berry-bearing alder, is also a deciduous shrub, and native of the Alps. It differs in no respect from the common sort, except that it has no thorns, and that it will grow to be rather taller, with tough, large, and doubly lacinated leaves. The smooth-leaved Alpine frangula is a variety of this species, with smooth leaves, and of a lower growth.

3. *R. catharticus*, or common purging-buckthorn, growing naturally in some parts of Britain. This grows to the height of twelve or fourteen feet, with many irregular branches at the extremities. The leaves are oval-lanceolate, finely serrated on the edges, their nerves converging together. The flowers grow in clusters, one on each foot-stalk, white, and in this species divided into four segments; the fruit is a round black berry, containing four seeds. The juice of the berries is a strong purgative, and is made use of for making the common syrup of buckthorn kept in

the shops. The bark is emetic; the juice of the unripe berries, with alum, dyes yellow, of the ripe ones a fine green; the bark also dyes yellow. The green color yielded by the berries, called verde vessie, is much esteemed by miniature painters. Of this species there are two varieties, viz. the dwarf buckthorn, a shrub of about a yard high, of a greenish color but little show; and the long-leaved dwarf buckthorn, which is a larger shrub, with leaves somewhat larger, but in other respects very similar to the dwarf buckthorn.

4. *R. frangula*, or berry-bearing alder, is a deciduous shrub, a native of England and most of the northern parts of Europe, and affords several varieties.

5. *R. insectorius*, or narrow-leaved buckthorn, is an evergreen shrub or tree, and native of Spain. It grows to ten or twelve feet and sends forth several branches from the bottom to the top. They are covered with a blackish or dark-colored bark, and each of them is terminated by a long sharp thorn. The fruit continues on the trees all winter, making a beautiful appearance among the narrow-clustered leaves at that season.

6. *R. lotus*, the Lybian lotus, has the leaves, prickles, flowers, and fruit, of the zizyphus; only with this difference that the fruit is here round, smaller, and more luscious, and at the same time the branches, like those of the paliurus, are neither so much jointed nor crooked. It is proper, however, to distinguish between these shrubs and a herb often mentioned by the ancients under the name of lotus, which, Homer says, was the food of the horses of Achilles, and Virgil mentions as proper to increase the milk of sheep. See *Lotus*.

7. *R. oleoides*, the olive-leaved buckthorn, is an evergreen shrub, a native of Spain, and grows to eight or ten feet. It sends forth numerous branches, each of which is terminated by a long sharp spine. The flowers are small, of a whitish green color, and are succeeded by round black berries.

8. *R. paliurus*, or thorn of Christ, is a deciduous shrub or tree, a native of Palestine, Spain, Portugal, and Italy. It will grow to nearly the height of fourteen feet, and is armed with sharp thorns, two of which are at each joint, one of which is about half an inch long, straight and upright; the other is scarcely half that length, and bent backward; and between them is the bud for next year's shoot. June is the time of flowering, and the flowers are succeeded by a small fruit, surrounded by a membrane. 'This plant,' says Hanbury, 'is probably the sort of which the crown of thorns for our Blessed Saviour was composed. The branches are very pliant, and the spines of it are at every joint strong and sharp. It grows naturally about Jerusalem, as well as in many parts of Judea; and the ancient pictures of our Saviour's crucifixion confirm this.'

9. *R. zizyphus*, or jujub, is the species in which the lac insect forms its cells, and produces the wax called gum lac.

**RHAMPHASTOS**, in ornithology, the toucan, a genus belonging to the order of picæ.

The bill is very large, and serrated outwardly. The nostrils are situated behind the base of the beak; and in most of the species the feet are toed, with two toes forward, and two backwards. The tongue is long, narrow, and feathered on the edges. Mr. Latham enumerates fifteen different species. We can only afford room for a description of the red beaked toucan, which will serve as a type of the rest. This bird is about the size of a jackdaw, and of a similar shape, with a large head to support its monstrous bill. This bill, from the angles of the mouth to its point, is six inches and a half in length, and its breadth in the thickest part is a little more than two. Its thickness near the head is one inch and a quarter; and it is a little rounded along the top of the upper chap, the under side being rounded also; the whole of the bill extremely slight, and but little thicker than parchment. The upper part is of a bright yellow, except on each side, which is of a fine scarlet color; as is also the lower part, except at the base, which is purple. Between the head and the bill there is a black line of separation all round the base of the bill; in the upper part of which the nostrils are placed, and almost covered with feathers; which has occasioned some to say that the toucan has no nostrils. Round the eyes, on each side of the head, is a space of bluish skin, void of feathers; above which the head is black, except a white spot on each side joining to the base of the upper part of the bill. The hinder part of the neck, the back, wings, tail, belly, and thighs, are black. The under side of the head, throat, and the beginning of the breast, are white. Between the white on the breast, and the black on the belly, is a space of red feathers, in the form of a new moon, with its horns upwards. The legs, feet, and claws, are of an ash color; and the toes stand like those of parrots, two before and two behind. It is said that this bird, though furnished with so formidable a beak, is harmless and gentle, being easily made tame so as to sit and hatch its young in houses. It feeds on vegetables, and prefers pepper. Its bill is hollow, and very light, so that it cannot peck or strike smartly therewith. Its tongue is long, thin, and flat; and is moved up and down, and often extended five or six inches from the bill. It is of a flesh color, and fringed on each side with very small filaments, exactly resembling a feather. It is probable that this long tongue has greater strength than the thin hollow beak that contains it. This bird builds its nest in holes of trees, which have been previously scooped out for this purpose. No bird secures its young better from injury than the toucan. It has not only birds, men, and serpents, to guard against, but a numerous tribe of monkeys. The toucan, however, scoops out its nest into the hollow of a tree, leaving only a hole large enough to go in and out at. There it sits, with its great beak, guarding the entrance; and, if a monkey ventures a visit, the toucan gives him such a welcome that he is glad to escape. The toucan is only found in the warm climates of South America, where it is in great request, both for the delicacy of its flesh, which is tender and nourishing, and for the beauty of its plumage, particularly the feathers of the breast.

**RHAMPSINITUS**, an opulent king of Egypt, who succeeded Proteus. He built a large stone tower at Memphis, where he deposited his riches, of which he was robbed by the artifice of the architect.—Herodotus.

**RHAMSES**, or **RAMISES**, a powerful king of Egypt, who, with an army of 700,000 men, conquered Ethiopia, Libya, Persia, and other eastern kingdoms. Pliny says Troy was taken in his reign. Some suppose him the same with Sesostris.

**RHAPIS**, in botany, a genus of the monogynia order, and hexandria class of plants; natural order first, palmæ: CAL. monophyllous; trifid spatha: COR. monopetalous and trifid. There are two species, viz.—*R. arundinacea*, simple leaved rhaps, a native of Carolina; and *R. flabelliformis*, or ground ratan, a native of China.

**RHAPSODI**, or **RHAPSODISTS**, in antiquity, persons who travelled from place to place, singing parts of Homer's poems. They were clothed in red when they sung the Iliad, and in blue when they sung the Odyssey. They performed in the theatres, and sometimes strove for prizes in contests of poetry, singing, &c. After the two antagonists had finished their parts, the two pieces or papers they were written in were joined together again: whence the name, viz. from *ραπτω*, suo, to sew, and *ωδη*, canticum, a song. But there seem to have been other rhapsodi of higher antiquity than these, who composed heroic poems, or songs in praise of heroes and great men, and sung their own compositions from town to town, for a livelihood; of which profession, it is said, was Homer himself. Hence some critics, instead of the former origin, derive the word rhapsodist from *ραβδω αδειν*, to sing with a laurel-rod in the hand, which, it seems, was the badge of the primitive rhapsodi. Philochorus, again, derives the word from *ραπτειν τας ωδας*, q. d. *συντιθεναι*, to compose songs or poems; as if they were the authors of the poems they sung. This opinion, to which Scaliger inclines, reduces these rhapsodi to the second kind. It is probable that these rhapsodists were all of the same class, whatever distinction some authors may imagine among them; and that their business was to sing or rehearse poems, either of their own or other people's composition, as might best serve their purpose, which was gaining a pecuniary advantage by them.

**RHAPSODOMANCY**, an ancient kind of divination, performed by taking a passage of a poet at hazard, and reckoning it as a prediction of what was to come to pass. There were various ways of practising this rhapsodomancy. Sometimes they wrote several papers or sentences of a poet on so many pieces of wood or paper, shook them together in an urn, and drew out one which was accounted the lot; sometimes they cast dice on a table whereon verses were written, and that whereon the die lodged contained the prediction. A third method was by opening a book, and taking some verse at first sight. This method they particularly called the *sortes Prænestinæ*; and afterwards made use of *sortes Homericae*. *sortes Virgilianæ*, &c.

**RHAPSODY**, *n. s.* } *Gr. ραψωδια; ραπτω,*  
**RHAPSODIST.** } to sew, and *ωδη*, a song.  
 Any number of parts joined together, without necessary or due connexion: a writer in this unconnected way.

Such a deed, as sweet religion makes  
 A rhapsody of words. *Shakspeare. Hamlet.*

This confusion and rhapsody of difficulties was not to be supposed in each single sinner.

*Hammond.*

He that makes no reflections on what he reads only loads his mind with a rhapsody of tales fit for the entertainment of others.

*Locke.*

The words slide over the ears, and vanish like a rhapsody of evening tales.

*Watts on the Mind.*

Ask our rhapsodists, if you have nothing but the excellence and loveliness of virtue to preach, and no future rewards or punishments, how many vicious wretches will you ever reclaim?

*Watts.*

**RHAYADER-GWY**, or **Goww**, a market-town of Radnorshire, on the river Wye. It is divided into four streets in the form of a cross, and anciently had a very considerable castle, part of the foundations of which may be still traced. In the centre of the town stands the hall, a handsome square building of stone, erected in 1768. The church is a respectable modern structure, in the form of an oblong square, with a quadrangular stone tower and turrets. At the upper end of the town, near the parsonage house, is a new-built free-school, and there is also a meeting-house for dissenters. The town is governed by a bailiff, and joins with New Radnor in sending a member to parliament. In the town is a small manufacture of coarse cloth. Market on Wednesday.

**RHAZIS**, or **RHEASES**, a celebrated Arabian physician and chemist, of great learning and experience, born at Rhei, in Chorosana, in 852. Dr. Mead translated his work on the Small-Pox; the rest of his works were printed in folio, in 1548.

**RHEA**, in the mythology, the daughter of Coelus and Terra, sister and wife of SATURN; the same with CYBELE or OFS. See these articles.

**RHEA AMERICANA**, in ornithology, the American ostrich, is very little smaller than the common one: the bill is sloped like that of a goose, being flat on the top and rounded at the end: the eyes are black, and the lids furnished with hairs: the head is rounded, and covered with downy feathers; the neck is two feet eight inches long, and feathered; from the tip of one wing to that of the other extended, the length is eight feet; but from the want of continuity of the webs of the feathers, and their laxity of texture, the bird is unable to raise itself from the ground; it is, however, capable of greatly assisting itself by their motion in running, which it does very swiftly. The legs are stout, bare of feathers above the knees, and furnished with three toes, all placed forwards, each having a straight and stout claw as in the cassowary; on the heel is a callous knob, serving as a back toe. The general color of plumage is dull gray mixed with white, inclining to the latter on the under parts; the tail is very short and not conspicuous, being entirely covered with long, loose, and floating feathers, originating from the lower part of the back

and rump, and entirely covering it; the bill and legs are brown. Molina says the body in some is white, in others black. It is fond of flies, which it catches with great dexterity, and will also, like the common ostrich, swallow bits of iron, and any other trash offered to it. In common with the ostrich of the old world, it lays a number of eggs, from forty to sixty, in the sand, each of them holding a quart; but it differs from that bird in many particulars, especially in wanting the callosity on the sternum, and spurs on the wing. With these last the common ostrich is known to defend itself; in defect of them this one uses the feet with such address as to become at once a furious and dangerous antagonist. The female calls its young ones together with a kind of whistling note somewhat similar to that of a man: when young it is very tame, frequently following the first creature it meets with. The flesh is said to be very unpalatable. They are found in various parts of South America, from Patagonia to Guiana.

RHEEDE (N.), esq., an eminent botanist of the sixteenth century. He was governor of Malabar, and published a well known work, entitled *Hortus Malabaricus*. We have seen no memoir of him.

RHEEDIA, in botany, a genus of the monogynia order, and polyandria class of plants: cor. tetrapetalous: CAL. none: the fruit is a trispermuous berry.

RHEGIUM, in ancient geography, a very ancient city of Italy. It was a city of the Brutti, a colony of Chalcidians from Eubœa, surnamed Julium, from a fresh supply of inhabitants sent thither by Augustus, after driving Sextus Pompeius out of Sicily (Strabo); and thus was in part a colony, retaining still the right of a municipium. Virgil (l. iii. v. 414) thus describes it:—

Hæc loca, vi quondam, et vastâ convulsa ruinâ  
(Tantum ævi longinqua valet mutare vetustas)  
Dissiluisse ferunt, cum protinus utraque tellus  
Una foret; venit medio vi pontus, et undis  
Hesperium Siculo latus abscedit; arvaque et urbes  
Littore diductas angusto interluit æstu.

RHEIMS, or REIMS (anciently Remi), a large city of France, in the department of the Marne. It stands in a fine plain, on the banks of the Vesle, surrounded by a chain of low hills, covered with vineyards. The space enclosed by the walls is very large, but a large part of it, particularly on the south-west side, is occupied by gardens. The form of the city is oblong, having its length from south-east to north-west, and it is surrounded with a ditch and earthen mound, planted on both sides with double rows of trees; the fortifications of the city were levelled in 1812. The closely built part is a regular oval, of which the square called the Place Royale may be considered the centre. The streets in general are wide and straight; in the old quarters, however, they are often winding and narrow. One of the finest leads in a straight line, across the whole width of the town, from the eastern to the western gate, passing through the centre of the royal square. The Place St. Remy, at the southern extremity of the town, though of an irregular shape, is pleasant. The houses throughout Rheims want in general height; hence there is little that is striking in their appearance. But

the city has six fine gates. Two of them, viz the *Porte de Ceres*, and the *Porte de Mars*, have retained their Roman names. The town is supplied with water by pipes from the Vesle. The cathedral, a vast Gothic edifice of the twelfth century, is one of the finest specimens of that kind of architecture in France. The portal is a chef d'œuvre, except that the frontispiece is loaded with a profusion of indifferent sculptures. In this church the ceremony of anointing or consecrating the kings of France formerly took place. A second object of interest formerly was the church of St. Nicaise, with its arch and pillar, said to shake on the ringing of one of the bells. In that of St. Reme was deposited the holy oil of the French kings; brought from heaven, it is said, by a dove; and preserved through the feuds of the Revolution by at least an equal miracle. The episcopal palace is a fine building; as also the Hotel de Ville. Here are traces of an amphitheatre, and the remains of a Roman triumphal arch: three hospitals; a small university; a royal college, and a high school. The archbishop is primate of France. Inhabitants 35,000. The manufactures are cotton, woollens, and hats. It was the birth place of Colbert.

RHEINFELS, or RHINFELS, a fortress of the Prussian grand duchy of the Lower Rhine, stands on an island in the Lower Rhine, at St. Goar, between Coblenz and Bacharach. It was besieged by the French in 1672, but without success: in 1794 it was taken and dismantled by them. Over against it stands New Catzenelnbogen, a very strong castle on a high rock.

RHEINGAU, or RHINGAU, a district of the duchy of Nassau, Germany, on the north bank of the Rhine. It extends from Biberach to Rudesheim, and is about twelve miles long and four broad, producing the best quality of Rhenish wine.

RHEINTHAL, i. e. the Valley of the Rhine, a district of the canton of St. Gall, Switzerland, lying along the Rhine, from the lake of Constance to the lordship of Sax. It is about sixteen miles long and four broad, having in the immediate neighbourhood of the Rhine a gravelly soil, and the population thin; but at a greater distance flax, vines, fruit, and maize, are all raised with success. The chief employment consists in spinning and weaving cotton and flax. The majority are Calvinists, but there are a good many Catholics, and both sects in many places use the same church. The chief town is Rheineck. Inhabitants 15,000. This is also the name of a small track in Baden, extending along the right bank of the Rhine, near Rheinfelden.

RHENANUS (Beatus), a learned German, born at Scelestat in 1485, whence he removed to Basil, where he corrected the press with Frobenius, and contracted a friendship with Erasmus. He wrote *The Life of Erasmus*: Notes upon Tertullian, and other classics; but his chief work is his *Res Germaniæ*, in 2 vols. folio. He died at Strasburg in 1547.

RHENE, in ancient geography, a small island in the Ægean Sea, about 200 yards from Delos, whence it is sometimes called Delos Minor. It is about eighteen miles in circumference.—Thucyd. 3. Strabo x.

**RHENUS**, in ancient geography, the Rhine, a large river of Germany, celebrated in ancient history. It rises among the Alpes Leponticæ, or Grisons; and, first traversing the Lacus Acronius, divides the Rhæti and Vindelicii from the Helvetii, and then the Germani from the Gauls and Belgæ; and running from south to north for the greater part of its way, and at length bending its course west, it empties itself by three mouths into the German Ocean, viz. the western, or Helias; the northern, or Fleuvus; and the middle between both these, which retains the original name, Rhenus (Pliny and Ptolemy). Mela and Tacitus mention two channels, and as many mouths, the right and left; the former running by Germany, and the latter by Gallia Belgica: and thus also Asinius Pollio, and Virgil; the trench of Drusus not being made in their time, whereby the middle channel was much drained and reduced, and therefore overlooked by Tacitus and Mela. See **RHINGE**.

**RHESE** (John David), M.D., was born in the isle of Anglesea, in 1534, and elected fellow of Christ Church College, Oxford, in 1555. He took his degree at Sienna, and was so complete a master of the Italian language as to be appointed moderator of the school at Pistoia, in Tuscany. He died at Brecknock about 1609.

**RHESUS**, in fabulous history, king of Thrace, son of the Strymon by the Muse Terpsichore, or, according to some, of Eioneus and Euterpe. After many warlike exploits in Europe, he went to assist Priam, king of Troy, against the Greeks. The Trojans were anxious for his arrival, as an oracle had declared that Troy should never be taken if the horses of Rhesus drank the waters of the Zanthus, and ate the grass of Troy. Diomedes and Ulyssus were therefore sent to intercept Rhesus: they entered his camp in the night, killed him, and carried off his horses.—Homer.

**RHETICUS** (George), a learned German astronomer, born at Feldkirk, in the Tyrolese, in 1514. He became professor at Wirtemberg, but left his chair to improve himself under Copernicus; after which he resumed his chair. He went to Poland, and afterwards to Cassaria, in Hungary, where he died in 1576.

**RHETORES**, amongst the Athenians, were ten orators elected by lot to plead public causes. The orators at Rome were not unlike the Athenian rhetores.

**RHETORIANS**, a sect of heretics in Egypt, so denominated from Rhetorius, their leader.

**RHETORIC**, *n. s.* } Fr. *rhetorique* ;  
**RHETORICAL**, *adj.* } Gr. *ῥητορικη* .  
**RHETORICALLY**, *adv.* }  
**RHETORICATE**, *v. n.* } The art of speaking with elegance; and the power of persuasion; oratory. See **ORATORY**. Rhetorical and rhetorician, adjective, mean, pertaining to, or befitting this art: the adverb corresponding: to rhetoricate is, to play the orator; address the passions: a rhetorician, one who teaches or practises rhetoric.

**RHETORIC** is the art of clothing the thoughts in the most agreeable and suitable form, to produce persuasion, to excite the feelings, to communicate pleasure. Speech is addressed to the understanding, the will, and the taste; it treats

of the true, the beautiful, and the good; and is, therefore, didactic, critical, and pathetic or practical. These different objects are often united in the same work, which, therefore, partakes of all the three characters above mentioned, but, at the same time, one or the other character so far prevails as to give a predominant temper to the whole. In a narrower sense, *rhetoric* is the art of persuasive speaking, or the art of the orator, which teaches the composition and delivery of discourses intended to move the feelings or sway the will of others. These productions of the rhetorical art are designed to be pronounced, in the presence of hearers, with appropriate gesture and declamation; and they often, therefore, require a different style of composition and arrangement from those works which are intended for readers, or simply to be read and not oratorically declaimed, and which are embraced in the jurisdiction of rhetoric in its widest sense. The Romans distinguished three kinds of eloquence—the demonstrative, occupied with praise or blame, and addressed to the judgment; the deliberative, which acts upon the will and the inclinations by persuasion or dissuasion; and the judicial or forensic, which is used in defending or attacking. The Greeks divided discourses according to their contents as relating to precepts (*λογος*), manners (*ἦθη*), and feelings (*παθη*), and as, therefore, calculated to instruct, to please, and to move—a division easily reconcileable with the former. The Romans had, also, a corresponding division into the *genus dicendi tenue, mediocre* and *sublime*. Another division of eloquence, founded on the subject to which it relates, is into academical, sacred (pulpit eloquence), and political. The two latter only allow of the lofty flights of eloquence. In the wider sense, as above explained, rhetoric treats of prose composition in general, whether in the form of historical works, philosophical dissertations, practical precepts, dialogues, or letters, and, therefore, includes the consideration of all the qualities of prose composition, purity of style, structure of sentences, figures of speech, &c.; in short, of whatever relates to clearness, preciseness, elegance, and strength of expression. In the narrower sense of rhetoric, as the art of persuasive speaking, it treats of the invention and disposition of the matter. The latter includes the arrangement of the parts, which are the exordium or introduction, narration (when necessary), proposition and division, proof or refutation, and conclusion or peroration, and the elocution, which relates to the style, and requires eloquence, purity, and precision. The delivery, or pronunciation, also falls here. Aristotle, Cicero, and Quintilian are the principal writers on rhetoric among the ancients; and the most valuable English works on this subject are, Campbell's Philosophy of Rhetoric, Blair's Lectures on Rhetoric, and the Elements of Rhetoric by Holmes.

**RHEUM**, *n. s.* } Fr. *rheume*; Gr. *ῥευμα*. The **RHEUM**'s, *adj.* } thin watery matter about the mouth, eyes, &c.: abounding in rheum.

**RHEUM**, in botany, rhubarb, a genus of the monogynia order, and enneandria class of plants; natural order twelfth, holoracæ; **CALL.** none:



cor. sexfid and persistent: and there is one triquetrous seed. There are five species, viz.

1. *R. Arabicum*, the currant rhubarb of Mount Libanus, has a thick fleshy root, very broad leaves, full of granulated protuberances, and with equal foot-stalks, and upright firm stems three or four feet high, terminated by spikes of flowers, surrounded by a purple pulp.

2. *R. compactum*, the Tartarian rhubarb, with a large, fleshy, branched root, yellow within; crowned by very large, heart-shaped, somewhat lobated, sharply indented, smooth leaves, and an upright large stem, five or six feet high, garnished with leaves singly, and branching above; having all the branches terminated by nodding panicles of white flowers. This has been supposed to be the true rhubarb; which, however, though of superior quality to some sorts, is accounted inferior to the rheum palmatum.

3. *R. palmatum*, palmated-leaved true Chinese rhubarb, has a thick fleshy root, yellow within; crowned with very large palmated leaves, being deeply divided into accumulated segments, expanded like an open hand; upright stems, five or six feet high or more, terminated by large spikes or flowers. This is the true foreign rhubarb, the purgative quality of which is well known.

4. *R. rhaponticum*, common rhubarb, has a large, thick, fleshy, branching, deeply-striking root, yellowish within; crowned by very large, roundish, heart-shaped smooth leaves, on thick, slightly furrowed foot-stalks; and an upright strong stem, two or three feet high, adorned with leaves singly, and terminated by thick close spikes of white flowers. It grows in Thrace and Scythia, but has been long in the English gardens. Its root affords a gentle cathartic. It is, however, of inferior quality to the Chinese. The young stalks of this plant, in spring, are cut and peeled, and used for tarts.

5. *R. undulatum*, the undulated, or waved-leaved Chinese rhubarb, has a thick, branched deep-striking root, yellow within; crowned with large, oblong, undulate, somewhat hairy leaves, having equal foot-stalks, and an upright firm stem, four feet high; garnished with leaves singly, and terminated by long loose spikes of white flowers. All these plants are perennial in root, and the leaves and stalks are annual. The roots being thick, fleshy, and generally divided, strike deep into the ground; are of a brownish color without, and yellow within: the leaves rise in the spring, generally come up in a large head folded together, gradually expanding themselves, having thick foot-stalks; and grow from one to two feet high, or more, in length and breadth, spreading all around; amidst them rise the flower stems, which are garnished at each joint by one leaf, and are of strong and expeditious growth, attaining their full height in June, when they flower; and are succeeded by large triangular seeds, ripening in August. Some plants of each sort merit culture in gardens for variety; they afford a contrast by their luxuriant foliage, spikes, and flowers: and, as medical plants, they demand culture both for private and public use. They are propagated by seeds sown in autumn, soon after they are ripe, or early in spring, in an open

bed of deep light earth. Those for medical use should be sown where they are to remain, that the roots may grow large. Scatter the seeds thinly, either by broad-cast, or in drills one foot and a half distant. The plants will rise in spring, but not flower till the second or third year. When they are two or three inches high, thin them to eight or ten inches: those designed to stand, should be hoed out to one foot and a half or two feet distant. Keep the ground clean between them; and in autumn, when the stalks decay, cut them down, and dig between the rows. The roots remaining increase in size annually; and in the second or third year, will shoot up stalks, flowers, and perfect seeds. In three or four years the roots will be large; but the oldest are preferred. Rhubarb is a mild cathartic. See MEDICINE and PHARMACY.

RHEUMATISM, *n. s.* } Fr. *rheumatisme*;  
RHEUMAT'IC, *adj.* } Lat. *rheumatismus*;  
Gr. *ρευματισμος*. A distemper supposed to proceed from acrid humors: partaking of rheumatism or proceeding from rheum.

The moon, the governess of floods,  
Pale in her anger, washes all the air,  
That rheumatic diseases do abound. *Shakspeare.*

The throting quinsey, 'tis my star appoints,  
And rheumatism I send to rack the joints. *Dryden.*

*Rheumatism* is a distemper affecting chiefly the membrana communis musculorum, which it makes rigid and unfit for motion; and it seems to be occasioned almost by the same causes, as the mucilaginous glands in the joints are rendered stiff and gritty in the gout. *Quincy.*

The blood taken away looked very sily or rheumatic. *Fuycer.*

RHEUMATISM. See MEDICINE, Index.

RHEXIA, in botany, a genus of the monogynia order, and octandria class of plants; natural order seventeenth, calycanthymæ: CAL. quadrifid with four petals inserted into it; antheræ declining: CAPS. quadrilocular, within the belly of the calyx. Species seven, natives of America and the West Indies.

RHIANUS, an ancient Greek historian and poet of Thrace, originally a slave; who flourished about A. A. C. 200. He wrote an account of the war between Sparta and Messenia, which lasted twenty years; and a history of the principal events and revolutions in Thessaly. Of this work only a few verses are extant.

RHIGAS, or RIGAS (M.), a modern Greek patriotic author, was born in 1753, at Velestini, a town of Thessaly. He studied in the colleges of his country, and was early distinguished for his acquirements. Early in life he was sent to Bucharest, and resided there till 1790, partly engaged in commercial pursuits. He first conceived the project of a secret society, in opposition to the Turks, and associated among the discontented chiefs. He now went to Vienna, where he met with a number of rich Greek merchants; and, extending his correspondence to other parts of Europe, commenced a Greek journal, translated the Travels of Anacharsis the younger, and other French works; and composed a treatise on military tactics, and another on natural philosophy; he likewise drew up a grand chart of all Greece, in twelve divisions, noting not only the

present, but also the ancient names of all celebrated places. At length he was denounced by one of his associates to the Austrian government as a conspirator against the state; arrested at Trieste, and ordered to be delivered up to the Ottoman Porte: but he was, with his companions, drowned in the Danube, his conductors fearing the vengeance of Passwan Oglou. This took place in May 1798, when Rhigas was about five-and-forty years of age.

**RHINANTHUS**, in botany, elephant's head, a genus of the angiospermia order, and didymamia class of plants; natural order fortieth, personatæ: CAL. quadrifid, ventricose: CAPS. bilocular, obtuse, and compressed. Species ten, natives of the Cape, the Levant, and of Egypt.

**RHINE**, one of the greatest rivers of Europe, and the next in rank after the Danube and the Wolga, has its source in the central and highest part of Switzerland, on the north-east of Mount St. Gothard. Striking off to the north-east, it first receives the two rivers called by the Germans the Middle and Hither Rhine. The united waters now pass the town of Coire or Chur, become navigable, and hold a northern course to the lake of Constance, which they traverse. Issuing hence with a copious stream the Rhine flows to the west, and receives the Aar, the Reuss, and the Linmat, whose waters combine all the chief streams of West and Central Switzerland. It now continues to flow to the west, until it reaches Bâle, when it takes a northern direction, and receives the Neckar and Main on the side of Germany, and the Moselle from France. Entering the kingdom of the Netherlands, it turns suddenly to the west, and divides into two great branches, of which the southern takes the name of Waal, receives the Maese, and flows into the German Ocean by Dort, Rotterdam, and Williamstadt. The northern, or less considerable branch, divides first above, and afterwards below Arnheim; and the name of Rhine is finally retained only by a small slow stream, which passes Utrecht and Leyden in its way to the sands near Catwyk, through which it reaches the sea. From its source to Mentz this great river is known as the Upper Rhine, and from Mentz to Holland as the Lower Rhine. Its course altogether is about 700 miles.

Its waters are of a beautiful limpid green: its stream, rapid in the early part of its course, becomes afterwards deep and tranquil. In Switzerland and the scenery of its banks is often sublime; and below Schaffhausen it forms a cascade, which, though not the highest, is in mass of waters the largest in the southern part of Europe. From Bâle to Strasburg, and even to Gernersheim, a number of islands appear in the river; but at Mentz the banks of the Rhine assume a most beautiful aspect. From that city to Cologne they penetrate the finest part of Germany: castles, towns, and villages embellish every part of the prospect; hills rise from the banks, covered with vineyards to their summits; while towers and forts, the remains of remote ages, are frequently reflected by the water.

By the Rhine the timber of Suabia is conveyed to the Netherlands, and colonial produce transported from the coast to the interior of Germany

and Switzerland, and the passage-boats up and down afford a very commodious conveyance. The navigation is sometimes difficult, but seldom hazardous. At Cologne vessels from 100 to 150 tons burden, generally drawn by horses, are seen; but they use their sails when the wind is favorable. A spirited beginning has also been made on this river in steam navigation.

**RHINE, THE CIRCLE OF**, is a province of Bavaria, situated to the west of the river of this name, between Weissemburg on the south and Worms on the north. It consists of a tract of territory on the Upper Rhine, ceded by France in 1814, assigned by the congress of Vienna to Austria, and made over by the latter to Bavaria. Its form approaches to a square; the area being about 1800 square miles, intersected by branches of the Vosges mountains. The more favorable aspects exhibit vineyards, while the rugged summits are often romantically crowned with the ruins of castles. The province contains mines of quicksilver, iron, and coal, a few hardware manufactures, extensive pastures, and in the valleys wheat, oats, and barley. It is divided into four districts, of which the chief towns are Frankenthal, Landau, Kaiserslautern, and Deux Ponts. The Rhine is its eastern boundary. Of the other rivers the chief are the Queich and Lauter. Population 308,000.

The **RHINE** also gives name to a province of the grand duchy of Hesse, situated to the north of the Bavarian circle of the Rhine. Its area is about 1000 square miles. The valleys and small plains produce corn, flax tobacco, and vines: and the hills contain in certain parts mines of iron and salt; in others very good pasturage. The manufactures are of linen, cotton, and leather, which give rise to a brisk traffic.

**RHINE, LOWER**, the Prussian grand duchy of, is composed of territories taken in 1814 from France and the grand duchy of Berg, and assigned by the congress of Vienna. Justice has been since administered by the laws of France; but the provincial administration is that of the Prussian dominions. This duchy is bounded on the north by the province of Cleves and Berg, on the east by Nassau and Hesse-Darmstadt, on the south by the French, on the west by the Dutch frontier. It lies between 6° 0' and 8° 37' of E. long., and between 49° 20' and 51° 8' N. lat., having an area of 5700 square miles, and 950,000 inhabitants, and is included in the same military division as Westphalia. It is divided into the governments of Aix-la-Chapelle, Coblenz, and Treves. The capital is Aix-la-Chapelle.

This country is hilly, and the climate has sufficient warmth for vines in particular situations; but in the elevated tracts of the Hundsruock, the Eiffel, and Westerwald, the cold checks the growth of every thing but wood. The wine is best along the banks of the Rhine, Aar (or Ahr), and Moselle. On the whole, though it has extensive valleys, this duchy has no great extent of fertile soil. The lower ranks subsist, in a great measure, on potatoes. The other products are hops, tobacco, flax, potash, and in the hilly districts minerals. Grazing is followed more on the east than on the west of the Rhine. The manufactures of coarse woollens, leather, and

tobacco, are chiefly confined to the districts around Aix-la-Chapelle and Neuwied. On the east of the Rhine mining, and the preparing of metals, afford employment.

**RHINE, CIRCLE OF THE LOWER**, was one of the ten former circles of the German empire. Its figure was very irregular. The princes who chiefly had possessions here were the electors of Mentz, Treves, and Cologne, and the elector palatine. It is now divided among the states of Baden, Bavaria, Hesse-Darmstadt, Nassau, Prussia, and Hanover.

**RHINE, CIRCLE OF THE UPPER**, another abolished division of the German empire. It was cut in two by the circle of the Lower Rhine, and like it was very irregular in its outline. The area of the two circles exceeded 20,000 square miles. The members of the imperial body who had possessions in the circle of the Upper were more numerous than those in the Lower Rhine. The western half, contiguous to Alsace, was repeatedly invaded by the French, and remained in their hands from 1794 to 1814. Since that period this circle has been divided between Bavaria, Hesse-Cassel, Hesse-Darmstadt, &c.

**RHINE, LOWER (Bas Rhin)**, a considerable department of France, consisting of the north part of Alsace, and forming an oblong track, extending from north to south. The eastern side is formed by the Rhine, the western by the Vosges Mountains, which are nearly parallel to the course of the river. The surface, about 1900 square miles, is diversified with hills, forests, and small valleys, all pretty well cultivated. On the mountains, and in the vicinity of the Rhine, the soil is bare and stony, and in some places marshy; but in general it is fertile, and the average produce of corn exceeds the consumption. The products are wheat, barley, oats, flax, hemp, tobacco, madder, and rapeseed. In the mountains are mines of iron, copper, coal, and salt. The pastures are extensive, and vines are cultivated in some parts. The chief manufactures are hardware and linen. Cotton has been introduced since the close of the eighteenth century, and there are likewise fabrics of pottery, glass, china-ware, paper, &c. Situated to the east of the Vosges, the natural limit of France, this department is principally inhabited by Germans, and French is spoken only in the large towns. The Lutherans are computed at 160,000, the Calvinists at 25,000, and the rest, with the exception of the Jews, are Catholics. The department is divided into four arrondissements, viz. Strasburg the capital, Saverne, Bar, and Weissemburg. The treaty of Paris in 1815 curtailed it of Landau, and of a tract to the north of Weissemburg. Inhabitants 440,000.

**RHINE, UPPER (Haut Rhin)**, another department of the north-east of France, of an oblong form, the Rhine flowing along its eastern limit, and the long chain of the Vosges extending on its western side. Its extent is about 1700 square miles. It contains the southern division of Alsace, and has a stony soil on the mountains, but the plains and valleys are fertile. Its chief rivers, after the Rhine, are the Ill, the Laber, the Lauch, and the Largue. It has likewise several canals, and two lakes. Corn, hemp, flax, rape-

seed, wines, and tobacco, are raised in large quantities. Cherries are so abundant that the liquor called cherry water forms a considerable export. The mineral products are iron, coal, and, to a small extent, copper, lead, and antimony. Of coal, the quantity annually produced is about 1000 tons; of iron about 5000 tons. Linen, woollen, and lately cottons, are the manufactures; and, on a small scale, paper, leather, and glass. The inhabitants (in number 320,000) are almost all of German descent. The Protestant part are computed at 57,000; the Jews at 10,000; the Baptists at 3000; Catholics at 250,000. The department is divided into the arrondissements of Colmar, Altkirch, Neufbrisach, and Befort.

**RHINOCEROS, n. s.** Fr. *rhinocerot*; Gr.  $\rho\upsilon\nu$  and  $\kappa\epsilon\rho\alpha\varsigma$ . A beast of the East, armed with a horn on his nossel.

Approach thou like the rugged Russian bear,  
The armed *rhinoceros*, or Hyrcanian tyger;  
Take any shape but that, and my firm nerves  
Shall never tremble. *Shakspeare. Macbeth.*

If you draw your beast in an emblem, shew a landscape of the country natural to the beast; as to the *rhinoceros* an East Indian landscape, the crocodile, an Egyptian. *Peacham.*

**RHINOCEROS**, in zoology, a genus of quadrupeds belonging to the order of belluæ. The name is entirely Greek; but Aristotle takes no notice of them, nor any other Greek writer till Strabo, nor Roman till Pliny. It is probable they did not frequent that part of India into which Alexander had penetrated, since it was nearly 300 years after that Pompey first brought them to Europe. From this time till the days of Heliogabalus they were frequently exhibited in the Roman spectacles, and have often been transported into Europe in more modern times; but they were long very ill represented, and very imperfectly described, till some that arrived in London in 1739 and 1741 were inspected; by which the errors and caprices of former writers were detected. There are two species, viz.

1. *R. bicornis*, long known in Europe only by the double horns which were preserved in various cabinets. Dr. Sparman, in his voyage to the Cape of Good Hope, killed two of these animals, which he dissected and very minutely describes. The horns, he says, in the live animal are so mobile and loose, that, when it walks carelessly along, one may see them waggle about, and hear them clash and clatter against each other. In the Philosophical Transactions we have a description of the double-horned rhinoceros of Sumatra, by Mr. Bell, surgeon in the service of the East India Company at Bencoolen. It was a male; the height at the shoulder was four feet four inches; at the sacrum nearly the same: from the tip of the nose to the end of the tail eight feet five inches. From the appearance of its teeth and bones it was but young, and probably not near its full size. The shape was much like that of the hog. The general color was a brownish ash: under the belly, between the legs and folds of the skin, a dirty flesh-color. The head much resembles that of the single-horned rhinoceros; the eyes were small, of a brown color, the membrana nictitans thick and strong: the skin sur-

rounding the eyes was wrinkled; the nostrils were wide; the upper lip was pointed, and hanging over the under. There were six molares, or grinders, on each side of the upper and lower jaw, becoming gradually larger backward, particularly in the upper; two teeth in the front of each jaw; the tongue was quite smooth; the ears were small and pointed, lined and edged with short black hair, and situated like those of the single-horned rhinoceros. The horns were black, the larger was placed immediately above the nose, pointing upwards, and was bent a little back; it was about nine inches long. The small horn was four inches long, of a pyramidal shape, flattened a little, and placed above the eyes, rather a little more forward, standing in a line with the larger horn immediately above it. They were both firmly attached to the skull, nor was there any appearance of joint or muscles to move them. The neck was thick and short, the skin on the under side thrown into folds, and these folds again wrinkled. The body was bulky and round, and from the shoulder ran a line, or fold, as in the single-horned rhinoceros, though it was but faintly marked. There were several other folds and wrinkles on the body and legs; and the whole gave rather the appearance of softness; the legs were thick, short, and remarkably strong; the feet armed with three distinct hoofs, of a blackish color, which surrounded half the foot, one in front, the others on each side. The soles of the feet were convex, of a light color, and the cuticle on them not thicker than that on the foot of a man who is used to walking; the testicles hardly appeared externally; the penis was bent backward and opened about eighteen inches below the anus. The whole skin of the animal is rough, and covered very thinly with short black hair. The animal had not that appearance of armor which is observed in the single-horned rhinoceros.

2. *R. unicornis*, the length of which, says Buffon, from the extremity of the muzzle to the origin of the tail, is at least twelve feet, and the circumference of the body is nearly the same. Their food in a natural state is thistles and thorny shrubs, which they prefer to the soft pasture of meadows; but they are fond of the sugar cane, and eat grain of all kinds. 'The rhinoceros,' says Buffon, 'at the age of two years, is not taller than a young cow that has never produced. But his body is very long and very thick. His head is disproportionally large. From the ears to the horn there is a concavity, the two extremities of which, namely, the upper end of the muzzle, and the part near the ears, are considerably raised. The horn is black, smooth at the top, but full of wrinkles directed backward at the base. The nostrils are situated very low, being not above an inch from the opening of the mouth. The under lip is pretty similar to that of the ox; but the upper lip has a greater resemblance to that of the horse, with this advantageous difference, that the rhinoceros can lengthen this lip, move it from side to side, roll it about a staff, and seize with it any object he wishes to carry to his mouth. The tongue of the young rhinoceros is soft, like that of a calf. His eyes, in figure, resemble those of the hog, but

situated lower, or nearer the nostrils, than in any other quadruped. His ears are large, thin at the extremities, and contracted at their origin by a kind of angular rugosity. The neck is very short, and surrounded with two large folds of skin. The shoulders are very thick, and at their juncture there is another fold of skin, which descends upon the fore legs. The legs are round, thick, strong, and their joint bent backwards. This joint, which, when the animal lies, is covered with a remarkable fold of the skin, appears when he stands. The tail is thin, and proportionally short. It becomes a little thicker at the extremity, which is garnished with some short, thick, hard hairs. The female exactly resembles the male in figure and grossness of body. The skin is every where covered more or less with incrustations in the form of galls or tuberosities, which are pretty small on the top of the neck and back, but become larger on the sides. The largest are on the shoulders and crupper, are still pretty large on the thighs and legs, upon which they are spread all round, and even on the feet. But between the folds the skin is penetrable, delicate, and as soft to the touch as silk, while the external part of the fold is equally hard with the rest. This tender skin between the folds is of a light flesh color; and the skin of the belly is nearly of the same color and consistency. These galls or tuberosities should not be compared, as some authors have done, to scales. They are only simple indurations of the skin, without any regularity in their figure or symmetry in their respective positions. The flexibility of the skin in the folds enables the rhinoceros to move with facility his head, neck, and members. The whole body, except at the joints, is inflexible, and resembles a coat of mail. Dr. Parson remarks that this animal listened with a deep and long continued attention to any kind of noise; and that, though he was sleeping or eating, he raised his head, and listened till the noise ceased. These animals never assemble or march together in troops like elephants. Being of a more solitary and savage disposition, they are more difficult to hunt and to overcome. They never attack men, however, except when they are provoked, when they are very furious and formidable; but as they see only before them, and as they turn with great difficulty, they may be easily avoided. The skin of these animals is so extremely hard as to resist sabres, lances, javelins, and even musket balls, the only penetrable parts being the belly, the eyes, and about the ears. Hence the hunters generally attack them when they lie down to sleep. Their flesh is considered as excellent by the Indians and Africans, but especially by the Hottentots; and, if they were trained when young, they might be rendered domestic, in which case they would multiply more easily than the elephant. They inhabit Bengal, Siam, Cochinchina, the isles of Java and Sumatra, Congo, Ethiopia, and the country as low as the Cape. They love shady forests, the neighbourhood of rivers, and marshy places. They wallow in the mire like hogs, and thus give shelter in the folds of their skins to scorpions, centipedes, and other insects. Buffon and Edwards deny this; but it is generally



thought to be true. They bring forth only one young at a time, about which they are very solicitous. Their skin, flesh, hoofs, teeth, and even dung, are used in India medicinally. The horn, especially that of a virgin rhinoceros, is considered as an antidote against poison. This species is supposed to be oryx or Indian ass of Aristotle; and the bos unicornis or fera monoceros of Pliny. Many writers also consider it as the unicorn of scripture.

**RHIZOBALUS**, in botany, a genus of the tetragynia order, and polyandria class of plants; natural order twenty-third, trihilatæ: CAL. monophyllous, fleshy, and downy: COR. consisting of five petals, which are round, concave, fleshy, and much larger than the calyx; the stamina are very numerous, filiform, and longer than the corolla; the styli are four, filiform, and of the length of the stamina; the pericarp has four drupæ, kidney-shaped, compressed with a fleshy substance inside, and in the middle a flat large nut containing a kidney-shaped kernel. Of this there is only one species.

**R. pekia**. The nuts which are sold in the shops as American nuts are flat, tuberculated, and kidney-shaped, containing a kernel of the same shape, which is sweet and agreeable.

**RHIZOPHORA**, the mangrove, or candle of the Indians, in botany, a genus of the monogynia order, and dodecandria class of plants; natural order twelfth, holoracæ: CAL. quadripartite: COR. partite: SEED one very long, and carnosous at the base. These plants are natives of the East and West Indies, and often grow forty or fifty feet high. They grow only in water, and on the banks of rivers, where the tide flows up twice a day. They preserve the verdure of their leaves throughout the year. From the lowest branches issue long roots, which hang down to the water, and penetrate into the earth. In this position they resemble so many arcades, from five to ten feet high, which serve to support the body of the tree, and even to advance it daily into the bed of the water. The most natural way of propagating these trees is to suffer the several slender small filaments which issue from the main branches, to take root in the earth. The most common method, however, is that of laying the small lower branches in baskets of mould or earth till they have taken root. The bark is very brown, smooth, pliant when green, and generally used in the West India Islands for tanning of leather. Below this bark lies a cuticle or skin, which is lighter, thinner, and more tender. The wood is nearly of the same color as the bark; hard, pliant, and very heavy. It is frequently used for fuel. The wood is compact; almost incorruptible; never splinters; is easily worked; and, were it not for its enormous weight, would be commodiously employed in almost all kinds of works. To the roots and branches of mangroves that are immersed in the water oysters frequently attach themselves. The red mangrove grows on the sea-shore, and at the mouth of large rivers; but does not advance, like the former, into the water. It generally rises to the height of twenty or thirty feet, with crooked, knotty branches, which proceed from all parts of the trunk. The bark is slender, of a brown color, and, when

young, is smooth, and adheres very closely to the wood; but, when old, appears quite cracked, and is easily detached from it. Under this bark is a skin as thick as parchment, red, and adhering closely to the wood, from which it cannot be detached, till the tree is felled and dry. The wood is hard, compact, heavy, of a deep red, with a very fine grain. The pith or heart of the wood being cut into small pieces, and boiled in water, imparts a very beautiful red to the liquid, which communicates the same color to wool and linen. From the fruit of this tree, which when ripe is of a violet color, and resembles some grapes in taste, is prepared an agreeable liquor, much esteemed by the inhabitants of the Caribbee Islands. This species is generally called rope mangrove, from the use to which the bark is applied by the inhabitants of the West Indies. This bark, which, by reason of the great abundance of sap, is easily detached when green, from the wood, is beaten or bruised betwixt two stones, until the hard and woody part is totally separated from that which is soft and tender. This last, which is the true cortical substance, is twisted into ropes of all sizes, which are exceedingly strong, and not apt to rot in the water.

**RHODANUS**, a river of Gallia Narbonensis, rising in the Rhætian Alps, and falling into the Mediterranean Sea, near Marseilles. It is now called **RHONE**, which see.

**RHODE ISLAND**, or, more properly, **RHODE ISLAND AND PROVIDENCE PLANTATIONS**, one of the United States of North America, is bounded north and east by Massachusetts, south by the Atlantic, and west by Connecticut. Long. 71° 6' to 71° 52' W., lat. 41° 17' to 41° 42' N.; forty-nine miles long, and twenty-nine broad; containing 1580 square miles.

The counties, number of towns, population, and chief towns, are exhibited in the following Table:—

Counties.	Towns.	Popul.	Chief Towns.
Bristol . .	3	5,466	Bristol.
Kent . .	4	12,784	East Greenwich.
Newport .	7	16,534	Newport.
Providence	10	47,014	Providence.
Washington	7	15,414	South Kingston.
	31	97,212	

The most considerable towns are Providence, Newport, Bristol, Warren, South Kingston, East Greenwich, Smithfield, and the villages of Pawtucket, and Pawtuxet. The harbours are Newport, Providence, Wickford, Pawtuxet, Bristol, and Warren. There are thirty-one banks in this state.

There is a college at Providence, and a large Friends' boarding school recently established at the same place. There are seven academies in the state, at Bristol, Cumberland, East Greenwich, Newport, Smithfield, South Kingston, and Wickford. Public and private schools are supported in a greater or less degree, in various places. But public schools are not supported by law in Rhode Island, as in the other New England States. The number of congregations of

the several denominations of Christians in this state is stated as follows:—Baptists fifty-seven; Friends eighteen; Congregationalists eleven; Episcopalians five; Moravians one; Jews one.

The legislature is composed of a council of twelve, including the governor and lieutenant-governor, all chosen annually, and a house of representatives, consisting of seventy-two members, chosen twice a year; viz. on the third Wednesday in April, and on the fourth Tuesday in August. Judges and other civil officers are appointed yearly. The legislature meets at Newport twice a year, at Providence once, and once a year alternately at East Greenwich and South Kingston. This state sends two representatives to congress.

The rivers are Pawtucket, Providence, Pawtuxet, Pawcatuck, and Wood River. Narraganset Bay extends up from south to north between the mainland on the east and west, and embosoms many pleasant and fertile islands; among which are Rhode Island, from which the state derives its name, Canonicut, Prudence, Patience, Hope, Dyer's and Hog Islands. Block Island, off the coast in the Atlantic, is the most southerly land belonging to the state.

The face of the country is mostly level, except in the north-west part, which is hilly and rocky. The soil is generally better adapted to grazing than tillage. A large proportion of the western and north-western part of the state has a thin and lean soil; but the islands and the country bordering on Narraganset Bay are of great fertility, and are celebrated for their fine cattle, their numerous flocks of sheep, and the abundance and excellence of their butter and cheese; cedar, rye, barley, oats, grasses, and culinary roots and plants are in great abundance and perfection. The rivers and bays swarm with a variety of excellent fish. Iron ore is found in large quantities in several parts, and some copper; there is also an abundance of limestone, particularly in the county of Providence.

The manufactures of Rhode Island are extensive. They consist chiefly of iron, cotton, woollen, paper, and hats. The exports consist chiefly of flax-seed, lumber, horses, cattle, beef, pork, fish, poultry, onions, butter, cheese, barley, grain, spirits, and cotton and linen goods. They amounted, in 1816, to 612,794 dollars. The climate of this state is as healthy as that of any part of America; and it is more temperate than the climate of any of the other New England states, particularly on the islands, where the breezes from the sea have the effect not only to mitigate the heat in summer, but to moderate the cold in winter. The summers are delightful, especially on the island of Rhode Island.

RHODE ISLAND, Indian name Aquedneck Island, from which the state takes its name, situated in Narraganset Bay. Long. 71° 20' W., lat. 41° 25' N. It is about fifteen miles from north to south, and three and a half wide, and is divided into three townships, Newport, Portsmouth, and Middletown. It is a noted resort for invalids from southern climates. The island is exceedingly pleasant and healthful. Travellers, with propriety, call it the Eden of America. It suffered much by the revolutionary war.

Vol. XVIII.

Some of its most ornamental country seats were destroyed; and their fine groves, orchards, and fruit trees, wantonly cut down. The soil is of a superior quality. Between 30,000 and 40,000 sheep are fed on the island, besides neat cattle and horses. There is a valuable coal mine on the north-west part of the island.

RHODES, a celebrated island in the Archipelago, the largest and most easterly of the Cyclades, was known in ancient times by the names of Asteria, Ophiusa, Æthrea, Trinacria, Corymbia, Poessa, Attabyria, Marcia, Oloessa, Stadia, Telchinis, Pelagia, and Rhodus. In latter ages, the name of Rhodus, or Rhodes, prevailed, from the Greek word rhodon, a rose: the island abounding very much with these flowers. It is about twenty miles distant from the coasts of Lycia and Caria, and 120 miles in compass.

Pliny and several other ancient authors assert that Rhodes was formerly covered by the sea, but gradually raised its head above the waves, and became an island. Philo ascribes this event to the decrease of the waters of the ocean. If his conjecture be not without foundation, most of the isles of the Archipelago, being lower than Rhodes, must have had a similar origin. But it is much more probable that the volcanic fires which in the fourth year of the 135th Olympiad raised Therasia and Thera, known at present by the name of Santorin, from the depths of the sea, and have in our days thrown out several small islands adjacent, also produced in some ancient era Rhodes and Delos. The first inhabitants of Rhodes, according to Diodorus Siculus, were called the Telchinæ, who came originally from the island of Crete. These, by their skill in astrology, perceiving that the island was soon to be deluged, left their habitations, and made room for the Heliades, or descendants of Phœbus, who took possession of the island, and excelled all other men in learning, invented navigation, &c. In after ages, however, being infested with great serpents which bred in the island, they consulted the oracle in Delos, which advised them to admit Phorbus, a Thessalian, with his followers into Rhodes. This was done, and Phorbus, having destroyed the serpents, was, after his death, honored as a demigod. Afterwards a colony of Cretans settled in the island, and, a little before the Trojan war, Tlepolemus the son of Hercules was made king of it, and governed with great justice. After the Trojan war all the ancient inhabitants were driven out by the Dorians, who continued to be masters of the island for many ages.

A little before the expedition of Xerxes into Greece a republican form of government prevailed here; during which the Rhodians applied themselves to navigation, and became very powerful by sea, planting several colonies in distant countries. In the time of the Peloponnesian war the republic of Rhodes was rent into two factions, one of which favored the Athenians, and the other the Spartans; but at length, the latter prevailing, democracy was abolished, and aristocracy introduced. About 351 B. C. we find the Rhodians oppressed by Mausolus king of Caria, and at last reduced by Artemisia his widow. In

2 P

this emergency they applied to the Athenians; by whose assistance they regained their liberty.

From the period above-mentioned to that of Alexander the Great the Rhodians enjoyed uninterrupted tranquillity. To him they voluntarily submitted; and were on that account highly favored by him: but no sooner did they hear of his death than they drove out the Macedonian garrisons, and once more became a free people. About this time happened a dreadful inundation at Rhodes; which, being accompanied with violent storms of rain, and hailstones of an extraordinary size, beat down many houses, and killed numbers of the inhabitants. As the city was built in the form of an amphitheatre, and no care had been taken to clear the pipes and conduits which conveyed the water into the sea, the lower parts were instantly laid under water. Many of the inhabitants fled to their ships. But the wall on a sudden bursting, we are told, asunder, and the water discharging itself into the sea, they were delivered from all farther danger. The Rhodians soon retrieved their losses by trade.

During the wars among the successors of Alexander, they observed a strict neutrality; whereby they enriched themselves so much that Rhodes became one of the most opulent states of the age; insomuch that they undertook the piratic war, and, at their own charge, cleared the seas of the pirates who had for many years infested the coasts of Europe and Asia. But, as the most advantageous branches of their commerce were derived from Egypt, they were more attached to Ptolemy, than to any of the neighbouring princes. When therefore Antigonus, having engaged in a war with Ptolemy about Cyprus, demanded succors of them, they intreated him not to compel them to declare war against their ancient ally. Antigonus immediately ordered one of his admirals to sail with his fleet to Rhodes, and seize all the ships that came out of the harbour; but the Rhodians, equipping a number of galleys, fell upon the enemy, and obliged them to retire with great loss. Hereupon Antigonus threatened to besiege their city with his whole army; and the only terms of accommodation to which he would hearken were, that the Rhodians should declare war against Ptolemy, and admit his fleet into their harbour. The Rhodians now sent ambassadors to all their allies, and to Ptolemy in particular, imploring their assistance; and the preparations on both sides were immense. Antigonus, being near eighty years of age, committed the management of the war to his son Demetrius, surnamed Polioretetes, or the taker of towns, who appeared before Rhodes with 200 ships and 170 transports, having on board 40,000 men, and 1000 other vessels laden with provisions and warlike engines; so that the whole sea between the continent and the island was covered with vessels.

Having landed his troops beyond the reach of the enemy's machines, Demetrius detached several small bodies to lay waste the country, employing the timber to fortify his camp with strong ramparts. The Rhodians, on their part, prepared for a vigorous defence. Many commanders, who had signalised themselves on other occasions, came to Rhodes to try their skill against Deme-

trius. The besieged taking an account of those who were capable of bearing arms, found that the citizens amounted to 6000, and the foreigners to 1000. Liberty was promised to all the slaves who should distinguish themselves by any glorious action, and the public engaged to pay the masters their ransom. A proclamation was likewise made, declaring, that whoever died in defence of his country should be buried at the public expense; that his parents and children should be maintained out of the treasury; that fortunes should be given to his daughters; and his sons should be crowned at the great festival of Bacchus. Demetrius, having planted his engines, began to batter with incredible fury the walls on the side of the harbour; but was for eight days successively repulsed, and the besieged set fire to some of the most powerful of his engines. He now, therefore, ordered a general assault to be made; but this also was repulsed with great slaughter. In a similar assault, next day, he was again forced to retire, after having lost a great number of men, and some officers. Having seized and fortified an eminence, near the city, Demetrius caused several batteries to be erected, which incessantly discharged against the walls stones of 150 lbs. weight; so that the towers began to totter, and several breaches were opened: but the Rhodians, unexpectedly sallying out, drove the enemy from this post, and overturned their machines. Their enterprising foe now ordered a scalade by sea and land at the same time; the attack was commenced with great fury; but the besieged defended themselves with the greatest intrepidity and success. After the combat had lasted many hours, with great slaughter on both sides, Demetrius retired: but soon returned with new vigor to attack the fortifications which defended the harbour. Here he caused a vast quantity of burning torches and firebrands to be thrown into the Rhodian ships; and at the same time galled them with showers of darts, arrows, and stones. However, the Rhodians put a stop to the fire; and having, with great expedition, manned three strong ships, drove with such violence against the vessels on which the enemy's machines were planted that they were shattered in pieces, and thrown into the sea. Excestus, the Rhodian admiral, encouraged by this success, now attacked the enemy's fleet, and sunk many vessels, but was himself taken prisoner. Demetrius on this ordered a machine of a new invention to be built, which was thrice the height and breadth of those he had lost. But as it was entering the harbour, a dreadful storm arising, drove it against the shore, with the vessel on which it had been reared. The besieged, while the tempest was still raging, made a sally against the post of the Demetrians; and, though repulsed several times, carried it, obliging 400 of them to lay down their arms.

After this victory Demetrius framed the famous engine called *helepolis*, much larger than any military engine hitherto invented. See *HELEPOLIS*. It was moved upon eight strong and large wheels, whose fellies were strengthened with strong iron plates. To facilitate and vary its movements, castors were placed under it, whereby it was turned in an instant to that side

which the workmen and engineers desired. From each of the four angles a large pillar of wood was carried to about the height of 100 cubits, inclining to each other; the machine consisting of nine stories, whose dimensions gradually lessened. The first story was supported by forty-three beams, and the last by no more than nine. Three sides of the machine were plated over with iron, to prevent its being damaged by fire. In the front of each story were windows defended with shutters covered with skins stuffed with wool. This machine was moved forwards by 3000 of the strongest men of the whole army; but the art with which it was built greatly facilitated the motion. Demetrius caused likewise to be made several testudoes or penthouses, to cover his men while they advanced to fill up the trenches and ditches, and invented a new sort of galleries, through which those that were employed at the siege might pass and repass. He employed all his seamen in levelling the ground over which the machines were to be brought up, to the space of four furlongs. The number of workmen employed amounted to 30,000.

The Rhodians, observing these formidable preparations, raised a new wall within that which the enemy intended to batter. To accomplish this, they pulled down the wall of their theatre, the neighbouring houses, and even some temples, after having solemnly vowed to build more magnificent structures in honor of the gods, if the city were preserved. At the same time they sent out nine of their best ships to seize such of the enemy's as they could meet with, and thereby distress them for want of provisions. As these were commanded by their bravest sea-officers, they soon returned with an immense booty, and many prisoners. Among other vessels, they took a galley richly laden, on board of which they found a great variety of valuable furniture, and a royal robe, which Phila herself had wrought and sent as a present to her husband Demetrius. The Rhodians sent the furniture, the royal robe, and the accompanying letter, to Ptolemy, which highly exasperated Demetrius. The statues of Antigonus and his son Demetrius, however, were still allowed to remain in the city. Mining and countermining were now tried: and one Athenagoras, a Milesian, who had been sent to the assistance of the Rhodians by Ptolemy, promised to betray the city to the Demetrians. But this was only to ensnare them; for Alexander, a Macedonian whom Demetrius had sent with a body of troops to take possession of a post agreed on, no sooner appeared but he was taken prisoner by the Rhodians, who were waiting for him under arms. Athenagoras was crowned by the senate with a crown of gold, and presented with five talents of silver. Demetrius now placed all his hopes of reducing the city on his battering engines. Having therefore levelled the ground, he brought up his helepolis, with four testudoes on each side. Two others of an extraordinary size, bearing battering rams, were likewise moved forwards by 1000 men. Each story of the helepolis was filled with engines for discharging stones, arrows, and darts. When all things were ready his men assaulted the city on all sides. But, in the heat of the attack, am-

bassadors arrived from Cnidus, soliciting Demetrius to suspend further hostilities, and giving him hopes that they should prevail upon the Rhodians to submit to a capitulation. A momentary suspension of arms took place; but, the Rhodians refusing the conditions offered, the attack was renewed. At this crisis a fleet which Ptolemy had freighted with 300,000 measures of corn and pulse arrived very seasonably. A few days after came in safe two other fleets: one sent by Cassander, with 100,000 bushels of barley; the other by Lysimachus, with 400,000 bushels of corn, and as many of barley. The Rhodian troops now suddenly sallied out, and set fire to the enemy's batteries; built a third wall in the form of a crescent, which took in all that part that was most exposed to the enemy; and drew a deep trench behind the breach. They also detached a squadron of their best ships under Amyntas, who, meeting with some privateers commissioned by Demetrius, took both the ships and the men, among whom were Timocles, the chief of the pirates, and several officers of distinction of the fleet of Demetrius. These were soon followed by a numerous fleet of small vessels loaded with corn and provisions, sent them by Ptolemy, with 1500 men, under Antigonus, a Macedonian of great experience. While the Rhodians were thus signaling themselves in the defence of their country, a second embassy arrived from Athens and the other cities of Greece, soliciting Demetrius to make a peace. A cessation of arms was agreed upon, but, the terms offered by Demetrius being once more rejected by the Rhodians, hostilities were renewed; and Demetrius formed a detachment of 1500 of his best troops, under Alcimus and Mancius, two officers of experience, ordering them to enter the breach at midnight, and possess themselves of the strong posts about the theatre. To facilitate the execution of so dangerous an undertaking, he amused the enemy with false attacks by sea and land. Accordingly the detachment entered the breach, and fell upon those who defended the ditch with such vigor that, having slain the most part of them, they advanced to the theatre, and seized on the post adjoining. The darkness of the night prevented the Rhodians from dislodging the enemy. Next day they fought like men in despair, the enemy defending their post several hours without giving ground. At length the Rhodians, breaking into the enemy's battalion, and killing both their commanders, the rest were easily put into disorder, and all to a man either killed or taken prisoners. The Rhodians also lost many of their best commanders; and among the rest Damotetis, their chief magistrate. Demetrius was making preparations for a new assault, when he received letters from his father, enjoining him to conclude a peace with the Rhodians upon the best terms he could obtain: at the same time ambassadors arrived from the Ætolian republic, soliciting the contending parties to put an end to the war. Demetrius, however, was preparing once more to bring forward his helepolis, when a Rhodian engineer rendered it altogether useless. He undermined the tract of ground over which it was to pass; and when it came to the place it sunk so deeply into the



this emergency they applied to the Athenians ; by whose assistance they regained their liberty.

From the period above-mentioned to that of Alexander the Great the Rhodians enjoyed uninterrupted tranquillity. To him they voluntarily submitted ; and were on that account highly favored by him : but no sooner did they hear of his death than they drove out the Macedonian garrisons, and once more became a free people. About this time happened a dreadful inundation at Rhodes ; which, being accompanied with violent storms of rain, and hailstones of an extraordinary size, beat down many houses, and killed numbers of the inhabitants. As the city was built in the form of an amphitheatre, and no care had been taken to clear the pipes and conduits which conveyed the water into the sea, the lower parts were instantly laid under water. Many of the inhabitants fled to their ships. But the wall on a sudden bursting, we are told, asunder, and the water discharging itself into the sea, they were delivered from all farther danger. The Rhodians soon retrieved their losses by trade.

During the wars among the successors of Alexander, they observed a strict neutrality ; whereby they enriched themselves so much that Rhodes became one of the most opulent states of the age ; inasmuch that they undertook the piratic war, and, at their own charge, cleared the seas of the pirates who had for many years infested the coasts of Europe and Asia. But, as the most advantageous branches of their commerce were derived from Egypt, they were more attached to Ptolemy, than to any of the neighbouring princes. When therefore Antigonus, having engaged in a war with Ptolemy about Cyprus, demanded succors of them, they intreated him not to compel them to declare war against their ancient ally. Antigonus immediately ordered one of his admirals to sail with his fleet to Rhodes, and seize all the ships that came out of the harbour ; but the Rhodians, equipping a number of galleys, fell upon the enemy, and obliged them to retire with great loss. Hereupon Antigonus threatened to besiege their city with his whole army ; and the only terms of accommodation to which he would hearken were, that the Rhodians should declare war against Ptolemy, and admit his fleet into their harbour. The Rhodians now sent ambassadors to all their allies, and to Ptolemy in particular, imploring their assistance ; and the preparations on both sides were immense. Antigonus, being near eighty years of age, committed the management of the war to his son Demetrius, surnamed Poliorcetes, or the taker of towns, who appeared before Rhodes with 200 ships and 170 transports, having on board 40,000 men, and 1000 other vessels laden with provisions and warlike engines ; so that the whole sea between the continent and the island was covered with vessels.

Having landed his troops beyond the reach of the enemy's machines, Demetrius detached several small bodies to lay waste the country, employing the timber to fortify his camp with strong ramparts. The Rhodians, on their part, prepared for a vigorous defence. Many commanders, who had signalised themselves on other occasions, came to Rhodes to try their skill against Deme-

trius. The besieged taking an account of those who who were capable of bearing arms, found that the citizens amounted to 6000, and the foreigners to 1000. Liberty was promised to all the slaves who should distinguish themselves by any glorious action, and the public engaged to pay the masters their ransom. A proclamation was likewise made, declaring, that whoever died in defence of his country should be buried at the public expense ; that his parents and children should be maintained out of the treasury ; that fortunes should be given to his daughters ; and his sons should be crowned at the great festival of Bacchus. Demetrius, having planted his engines, began to batter with incredible fury the walls on the side of the harbour ; but was for eight days successively repulsed, and the besieged set fire to some of the most powerful of his engines. He now, therefore, ordered a general assault to be made ; but this also was repulsed with great slaughter. In a similar assault, next day, he was again forced to retire, after having lost a great number of men, and some officers. Having seized and fortified an eminence, near the city, Demetrius caused several batteries to be erected, which incessantly discharged against the walls stones of 150 lbs. weight ; so that the towers began to totter, and several breaches were opened : but the Rhodians, unexpectedly sallying out, drove the enemy from this post, and overturned their machines. Their enterprising foe now ordered a scalade by sea and land at the same time ; the attack was commenced with great fury ; but the besieged defended themselves with the greatest intrepidity and success. After the combat had lasted many hours, with great slaughter on both sides, Demetrius retired : but soon returned with new vigor to attack the fortifications which defended the harbour. Here he caused a vast quantity of burning torches and firebrands to be thrown into the Rhodian ships ; and at the same time galled them with showers of darts, arrows, and stones. However, the Rhodians put a stop to the fire ; and having, with great expedition, manned three strong ships, drove with such violence against the vessels on which the enemy's machines were planted that they were shattered in pieces, and thrown into the sea. Excestus, the Rhodian admiral, encouraged by this success, now attacked the enemy's fleet, and sunk many vessels, but was himself taken prisoner. Demetrius on this ordered a machine of a new invention to be built, which was thrice the height and breadth of those he had lost. But as it was entering the harbour, a dreadful storm arising, drove it against the shore, with the vessel on which it had been reared. The besieged, while the tempest was still raging, made a sally against the post of the Demetrians ; and, though repulsed several times, carried it, obliging 400 of them to lay down their arms.

After this victory Demetrius framed the famous engine called helepolis, much larger than any military engine hitherto invented. See HELEPOLIS. It was moved upon eight strong and large wheels, whose fellies were strengthened with strong iron plates. To facilitate and vary its movements, castors were placed under it, whereby it was turned in an instant to that side

the Rhodians on the continent. This castle he took by assault; and hence conveyed his land forces, under Fannius and Lentulus, over into the island. His fleet consisted of eighty ships of war and above 200 transports. The Rhodians no sooner saw it appear, but they went out again to meet the enemy. The second engagement was far more bloody than the first; many ships were sunk, and great numbers of men killed on both sides. But victory once more declared for the Romans, who immediately blocked up the city of Rhodes both by sea and land. As the inhabitants had not had time to furnish the city with sufficient provisions for a siege, some of them fearing that, if it were taken either by assault or by famine, Cassius would put all the inhabitants to the sword, as Brutus had lately done at Xanthus, privately opened the gates, and put him in possession of the town, which he nevertheless treated as if it had been taken by assault. He commanded fifty of the chief citizens to be brought before him, and sentenced them to die; others to the number of twenty-five, who had commanded the fleet or army, because they did not appear when summoned, he proscribed, and commanded the Rhodians to deliver up to him all their ships, and whatever money they had in the public treasury. He then plundered the temples; and is said not to have left one statue in the whole city, except that of the sun; boasting, at his departure, that he had stripped the Rhodians of all they had. From private persons he extorted above 8000 talents.

On the death of Cassius, Marc Antony restored the Rhodians to their ancient rights and privileges, bestowing upon them the islands of Andros, Naxos, Tenos, and the city of Myndus. But these the Rhodians so oppressed with taxes that Antony, though a great friend to the republic, was obliged to divest her of the sovereignty. From this time to the reign of the emperor Claudius we find no mention made of the Rhodians. That prince, as Dion informs us, deprived them of their liberty for having crucified some Roman citizens. However, he soon restored them to their former condition. Tacitus adds, that they had been as often deprived of, or restored to, their liberty, by way of punishment or reward for their different behaviour, as they had obliged the Romans with their assistance in foreign wars, or provoked them with their seditions at home. Pliny, who wrote in the beginning of Vespasian's reign, styles Rhodes a beautiful and free town. But Vespasian obliged it to pay a yearly tribute, and reduced the whole island to a Roman province. The pretor who governed it resided at Rhodes, as the chief city under his jurisdiction.

The island continued subject to the Romans till the reign of the emperor Andronicus; when Villaret, grand master of the knights of Jerusalem, then residing at Cyprus, finding himself much exposed to the attacks of the Saracens, resolved to exchange that island for Rhodes. Andronicus the eastern emperor possessed little more in it than a castle: nevertheless he refused to grant the investiture of the island to Villaret. The latter, therefore, without spending time in fruitless negotiations, sailed directly for Rhodes,

where he landed his troops, provisions, and war-like stores, in spite of the opposition made by the Saracens, who then united against the common enemy. As Villaret foresaw that the capital must be taken before he could reduce the island, he instantly laid siege to it. The inhabitants defended themselves obstinately; upon which the grand master thought proper to turn the siege into a blockade; but soon found himself so closely surrounded by the Greeks and Saracens that he could get no supply either of forage or provisions. But having at length obtained this by means of large sums borrowed of the Florentines, he came out of his trenches and attacked the Saracens, with a full resolution either to conquer or die. A bloody conflict ensued, in which a great number of the bravest knights were killed; but at length the Saracens gave way, and fled to their ships; upon which the city was immediately attacked and taken. The Greeks and other Christians had their lives and liberties given them, but the Saracens were all cut to pieces. The reduction of the capital was followed by that of all the other places of inferior strength throughout the island; and, in four years after their landing, the whole was subjugated, and the conquerors took the title of the Knights of Rhodes.

For many years those knights continued the terror of the Saracens and Turks, and sustained a severe siege from Mahomet II., who was compelled to abandon the enterprise; but at length the Turkish sultan Solyman resolved at all events to drive them from it. He attacked the city with a fleet of 400 sail, and an army of 140,000 men. The trenches were soon brought close to the counterscarp, and a strong battery raised against the town; which, however, did but little damage. Unfortunately for the besieged, their continual fire caused such a consumption of gunpowder that they began to feel the want of it; the perfidious d'Amaral, whose province it had been to visit the magazines, having amused the council with a false report that there was more than sufficient to maintain the siege. Solyman therefore thought it now advisable to set his numerous pioneers at work, digging of mines, and, ashamed and exasperated at his ill success, called a general council, in which he made some stinging reflections on his vizier, for having represented the reduction of Rhodes as a very easy enterprise. To avoid the effects of the sultan's resentment, Mustapha proposed a general assault on several sides of the town at once. This was immediately approved of, and the time appointed for the execution of it was on the 24th. Accordingly the town was assaulted at four different parts, after having suffered a continual fire for some time from their artillery. But the Rhodians were no less diligent in repulsing them with their cannon and other fire arms, melted lead, boiling oil, &c. The Turks at last, alike beset by the fire of the artillery and the arms of the Rhodian knights, were forced to abandon the attack with a considerable loss. In these attacks there fell about 15,000 of Solyman's best troops, besides several officers of distinction. Solyman was so discouraged by his ill successes that he was on the point of raising the siege, and would have ac-

tually done so, had he not been diverted from it by intelligence that the far greater part of the knights were either killed or wounded. This having determined him to try his fortune once more, the command of his forces was turned over to the bashaw Achmed, with orders to push the attack with all imaginable vigor. Achmed instantly obeyed, raised a battery of seventeen large cannon against the bastion of Italy, and quickly after made himself master of it, obliging the garrison to retire into the city. The grand master was now forced to demolish two of the churches, to prevent the enemy's seizing on them; and, with their materials, caused some new works and entrenchments to be made. The Turks, however, gained ground every day: at length, on the 30th of November, the last assault was to be given. The bashaw Pyrrus, who commanded it, led his men directly to the entrenchments, and this attack would have proved one of the most desperate that had yet been made, had not a vehement rain intervened, which carried away all the earth which the enemy had reared to serve them as a rampart; so that being now exposed to a continual fire they fell in such great numbers that the bashaw could no longer make them stand their ground. This last repulse threw the sultan into such a fury that none of his officers dared to come near him; and the shame of his having now spent nearly six whole months with a numerous army before the place, and having lost such myriads of his brave troops with so little advantage, had made him quite desperate. Pyrrus at length, having given it time to cool, ventured to propose offering the town a capitulation. This being relished by the sultan, letters were immediately despatched in his name, exhorting the city to submit, and threatening the knights with the most dreadful effects of his resentment if they persisted in their obstinacy. Other agents were employed in different places: to all of whom the grand master ordered his men to return this answer, that his order never treated with infidels but with sword in hand. At last, however, he called a council of all the knights, and informed them himself of the condition of the place. These all agreed, particularly the engineer Martinengo, that it was no longer defensible, and that no other resource was left but to accept the sultan's offers. These were in fact so advantageous that they immediately exchanged hostages; and Achmed, the sultan's minister, who knew his master's impatience to have the affair concluded, finally agreed with them upon the following terms: 1. That the churches should not be profaned. 2. That the inhabitants should not be forced to part with their children to be made janissaries. 3. That they should enjoy the free exercise of their religion. 4. That they should be free from taxes during five years. 5. That those who had a mind to leave the island should have free leave to do so. 6. That, if the grand master and his knights had not a sufficient number of vessels to transport themselves and their effects into Candia, the sultan should supply that defect. 7. That they should have twelve days allowed them, from the signing of the articles, to send all their effects on board. 8. That they should have the liberty of carrying away

their relics, chalices, and other sacred utensils belonging to the great church of St. John, together with all their ornaments and other effects. 9. That they should likewise carry with them all the artillery with which they were wont to arm the galleys of the order. 10. That the islands belonging to it, together with the castle of St. Peter, should be delivered up to the Turks. 11. That, for the more easy execution of these articles, the Turkish army should be removed at some miles distance from the capital. 12. That the aga of the janissaries, at the head of 4000 of his men, should be allowed to go and take possession of the place. From this time the island of Rhodes has been subject to the Turks; and, like other countries subject to that tyrannical yoke, has lost all its former importance.

Rhodes is separated from the south-west extremity of Anatolia by the channel of Rhodes, from three to four leagues wide. The north coast is low, but rises inland to a high mountain, flat at top. The soil is in general sandy, but well watered and tolerably fertile, producing corn, wine, oil, fruits, honey, &c. The island abounds with hares, woodcocks, partridges, snipes, and wild ducks. The climate is mild and healthy, the winter having neither frost nor snow, and the summer heats are tempered by the westerly sea breezes in that season.

The chief town, of the same name, is situated on the north-east point of the island, and built amphitheatrically on the side of a hill; it is surrounded by thick walls with towers, which give it an appearance of much greater strength than it possesses. The streets are narrow and crooked, and the houses mean. It has two ports; the smallest, named Dasca, has its entrance from the east, and is covered by several rocks, leaving only a channel for one vessel at a time; it has also jetties, but is filling up daily, and at present can only receive small merchant vessels. The second port, named Rhodes, faces the west, on which side it is sheltered, but is open to the north and north-east. It receives vessels of eighteen feet draft, and here Turkish vessels of war have been built of the pines the island affords.

The other places of any note are Lindo, on the east, at the head of a deep bay and at the foot of a high mountain, on the site of the ancient Lindus, celebrated for its temple of Minerva, of which some remains are still to be seen on the summit of the hill behind the town. On the south side of the bay is good anchorage, in eight to twelve fathoms, opposite a little village named Massary, where is shelter from the south-west winds, which often blow with violence during winter. Uxitcho is on the south-east. Cape Tranquille is the south point of the island. Off it is the isle of St. Catherine. Limonia (Teutlussa), Karki (Chalce), Piscopia (Telos), Nisari (Nysirus), and Madona, are between Rhodes and Stancho. Nisari, the most considerable, produces wheat, cotton, and wine, and has warm springs.

In the centre of the island of Rhodes rises mount Artemira, the ancient Atabyrus, a steep and lofty summit, commanding a most extensive view, not only over the island, but over all the surrounding seas and coasts. It is, in fact, a

pinnacle of a range of mountains, on which grow those forests of pine which supplied the ancient navies of the Rhodians, and were long sent in great quantities to the arsenal at Constantinople. They are now, however, greatly thinned. Beneath this range rises a tract of lower hills, which still produce some of that perfumed wine so much prized by the ancients. This culture might easily be greatly extended, as a great part of the hills fitted for it are at present neglected. The tract beneath, forming the greater portion of the island, slopes gradually down to the sea, and being watered by numerous streams, descending from the higher regions, is capable, under proper cultivation, of producing luxuriant crops. Rhodes, which might be the granary of the neighbouring islands, was very lately obliged to import a considerable portion of the grain which it consumes. The pacha, having assumed the monopoly of this article, found it his interest to perpetuate the poverty on which it depended. The consequence is, that a great part of the island is almost entirely waste. 'In travelling over it,' says Savary, 'you have the mortification of passing through several fine valleys, unadorned with either cottage or hamlet, and discovering no marks of cultivation. Wild roses hang around the foot of the rocks; beds of flowering myrrh perfume the air; tufts of laurel roses adorn the banks of the rivulets with their gaudy flowers. The husbandman here suffers the earth to waste her strength in pouring forth a profusion of weeds and useless plants, without taking pains to direct her fertility, and to enjoy her favors. Besides corn, there is a deficiency of olives for the consumption; and the quantity of cotton raised is barely sufficient for the supply of the island. The exportation of wine, figs, and other fruit, is, however, considerable.

Savary found the capital inhabited chiefly by the Turks; and five towns and forty-one villages inhabited by Greeks. The families in the island are stated at 4700 Turks, 2500 Greeks, and 100 Jews, making in all 7300 families, which, at five persons to each family, would amount to 36,500. Mr. Turner, a more recent traveller, calculates the whole number at 20,000. The Greeks, he says, inhabit forty-two villages, containing, in the whole, 14,000 of that nation. The rest of the population, consisting entirely of Turks and Jews, reside in the capital. But see our article GREECE, vol. x. 640.

**RHODIGINUS** (*Lucius Cœlius*), a learned Venetian, born at Rovigo, in 1450. He was the instructor of the celebrated Julius Cæsar Scaliger. He wrote many works, the chief of which is *Antiquæ Lectiones*, first printed at Basil. He died in Padua in 1525, aged seventy-five.

**RHODIOLA**, rose wort, in botany, a genus of the octandria order and diœcia class of plants, natural order thirteenth, succulentæ: **MALE CAL.** quadripartite: **COR.** tetrapetalous: **FEMALE CAL.** quadripartite: **COR.** none; nectaria four; pistils four; and there are four polyspermous capsules. There are two species,

1. *R. minor*, a native of the Alps, has purple flowers, which come out later than those of the *rhodiola rosea*; it is also of a smaller size.

2. *R. rosea* grows naturally in the clefts of the

rocks and rugged mountains of Wales, Yorkshire, and Westmoreland. It has a very thick fleshy root, which, when cut or bruised, sends out an odor like roses. It has thick succulent stalks like those of orpine, about nine inches long, closely garnished with thick succulent leaves indented at the top. The stalk is terminated by a cluster of yellowish herbaceous flowers, which have an agreeable scent, but are of short continuance. Both species are easily propagated by parting their roots, and require a shady situation, and dry undunged soil. The fragrance of the second species, however, is greatly diminished by cultivation.

**RHODIUM**, in chemistry, a metal first discovered by Dr. Wollaston among the grains of crude platinum. The mode of obtaining it in the state of a triple salt combined with muriatic acid and soda has been given under the article **PALLADIUM**. This may be dissolved in water, and the metal precipitated by zinc in the shape of a black powder. This powder exposed to heat continues black; but with borax it acquires a white metallic lustre, though it remains infusible. Sulphur and arsenic, however, render it fusible, and may afterwards be expelled by continuing the heat. The button, however, is not malleable. Its specific gravity appears not to exceed 11.

Rhodium unites easily with every metal that has been tried, except mercury. With gold or silver it forms a very malleable alloy, not oxidised by a high degree of heat, but becoming incrustated with a black oxide when slowly cooled. One-sixth of it does not perceptibly alter the color of gold, but renders it much less fusible. Neither nitric nor nitro-muriatic acid acts on it in either of these alloys; but if it be fused with three parts of bismuth, lead, or copper, the alloy is entirely soluble in a mixture of one part nitric acid with two parts of muriatic.

The oxide was soluble in every acid Dr. Wollaston tried. The solution in muriatic acid did not crystallise by evaporation. Its residuum formed a rose-colored solution with alcohol. Muriate of ammonia and of soda, and nitrate of potash, occasioned no precipitate in the muriatic solution, but formed with the oxide triple salts, which were insoluble in the alcohol. Its solution in nitric acid likewise did not crystallise, but silver, copper, and other metals precipitated it. The solution of the triple salt with muriate of soda was not precipitated by muriate, carbonate, or hydrosulphuret of ammonia, by carbonate or ferropussiate of potash, or by carbonate of soda. The caustic alkalis, however, throw down a yellow oxide, soluble in excess of alkali; and a solution of platinum occasions in it a yellow precipitate.

The title of this product to be considered as a distinct metal was at first questioned; but the experiments of Dr. Wollaston have since been confirmed by Descotils.

**RHODIUS** (John), an ancient Danish physician, born at Copenhagen in 1587. He published *Notes on Scribonius Largus*, and other works; and died in Padua in 1659.

**RHODODENDRON**, dwarf rose-bay, in botany, a genus of the monogynia order, and decandria class of plants, natural order eighteenth,

bicornes: CAL. quinquepartite: COR. funnel-shaped; stamina declining; CAPS. quinquelocular. There are ten species; the most remarkable are,

1. *R. chamæcistus*, or ciliated-leaved dwarf rose-bay, a low deciduous shrub, a native of Germany. It grows to the height of about three feet; the branches are numerous, produced irregularly, and covered with a purplish bark. The leaves are oval, spear-shaped, small, and in the under surface of the color of iron. The flowers are produced at the end of the branches in bunches, are of a wheel-shaped figure, pretty large, of a fine crimson color, and handsome appearance. They appear in June, and are succeeded by oval capsules containing ripe seeds in September.

2. *R. chrysanthemum*, a new species, discovered by professor Pallas in his tour through Siberia. In Siberia this species is used with great success in gouty and rheumatic affections.

3. *R. Dauricum*, the Daurian dwarf rose-bay, is a low deciduous shrub, and native of Dauria. Its branches are numerous, and covered with a brownish bark. The flowers are wheel-shaped, large, and of a beautiful rose-color: they appear in May, and are succeeded by oval capsules full of seeds, which in England do not always ripen.

4. *R. ferrugineum*, with smooth leaves, hairy on their under side, is a native of the Alps and Appennines. It rises with a shrubby stalk nearly three feet high, sending out many irregular branches covered with a purplish bark, and closely garnished with smooth spear-shaped entire leaves, whose borders are reflexed backward; the upper side is of a light lucid green, their under side of an iron color. The flowers are produced at the ends of the branches, are funnel-shaped, cut into five segments, and of a pale rose color. These plants are propagated by seeds; but, being natives of barren rocky soils and cold situations, they do not thrive in gardens, and for want of their usual covering of snow in the winter are often killed by frost in this country.

5. *R. hirsutum*, with naked hairy leaves, grows naturally on the Alps and several mountains of Italy. It is a low shrub, which seldom rises two feet high, sending out many ligneous branches, covered with a light brown bark, garnished closely with oval spear-shaped leaves, sitting pretty close to the branches. They are entire, having a great number of fine iron-colored hairs on their edges and under side. The flowers are produced in bunches at the end of the branches in May, having one funnel-shaped petal cut into five obtuse segments, and of a pale-red color. They make a good show, and are succeeded by oval capsules, containing ripe seeds, in August.

6. *R. maximum*, the American mountain laurel, is an ever-green shrub, and a native of Virginia, where it grows naturally on the highest mountains, and on the edges of cliffs, precipices, &c., where it reaches the size of a moderate tree, though with it seldom rises higher than six feet. The flowers continue by succession sometimes more than two months, and are succeeded by oval capsules full of seeds.

7. *R. ponticum*, the pontic dwarf rose-bay, is an evergreen shrub, a native of the east, and of most shady places near Gibraltar. It grows to the height of four or five feet. The leaves are spear-shaped, glossy on both sides, acute, and placed on short foot-stalks on the branches; the flowers, which are produced in clusters, are bell-shaped, and of a fine purple-color. They appear in July, and are succeeded by oval capsules containing seeds, which in this climate seldom attain to maturity.

**RHODOMAN** (Laurence), a learned German, born at Sasserwerf, in Upper Saxony, in 1546. He studied at the college of Ilfeld six years; and became an eminent Greek scholar. He wrote Greek verses, which are much admired. He translated the Greek poem of Quintus Calaber into Latin. He also translated Diodorus Siculus into Latin. He became professor of history in the university of Wirtemberg; and published several other works. He died in 1606 at Wirtemberg.

**RHODOPE**, a high mountain of Thrace, extending across the country, in an east direction, nearly to the Euxine Sea.

**RHODOPE**, in fabulous history, the wife of Hamus king of Thrace; who, preferring herself to Juno in beauty, was metamorphosed into the above mountain. Ovid vi. 87, &c.

**RHODOPE**, a celebrated Grecian courtesan, who was fellow servant with Æsop at the court of the king of Samos. She was carried to Egypt by Xanthus, and purchased by Charaxes of Mitylene, the brother of Sappho, who married her. She afterwards sold her favors at such a price that she collected a sum of money, with which she built one of the pyramids. Ælian says that one day, as she was bathing, an eagle carried away one of her sandals, and dropped it near king Psammeticus at Memphis, on which he made enquiry after the owner, and married her.

**RHODUS**. See **RHODES**.

**RHOE**, two of the Shetland Isles of Scotland, thus distinguished: Little Rhoe, lies near Mickle Rhoe, and contains about fourteen inhabitants, whose sole employment is fishing. Mickle Rhoe lies on the south of Mainland, and belongs to the parish of Delting. It is about twenty-four miles in circumference, and its inhabitants are chiefly employed in cultivating the fertile spots of the island, and in fishing. They also rear a number of sheep and black cattle, which have excellent pasture among the heath.

**RHOECUS**, in fabulous history: 1. One of the giants, killed by Bacchus in the war against the gods; 2. A centaur, who attempted to offer violence to Atalanta: also killed by Bacchus, at the marriage of Pirithous. Ovid. Met. xii. 301.

**RHOMB**, *n. s.* } Fr. *rhombe*; Lat. *rhombeus*;  
**RHOMBIC**, } Gr. *ρῶμβος*. A quadrangle figure, formed by two equal and right cones joined together at their base: rhombic is, shaped as a rhomb: rhomboid, a figure approaching that shape.

See how in warlike muster they appear,  
 In rhombs and wedges; and half moons and wings.

Many other sorts of stones are regularly figured. The asteria in form of a star, and they are of a rhombic figure.

Many other sorts of stones are regularly figured ; and they are of a *rhombick* figure ; talk, of such as are *rhomboid*. *Grew.*

Another *rhomboidal* selenites, of a compressed form, had many others infixed round the middle of it.

*Woodward.*

**RHOMBOID**, in geometry, a quadrilateral figure whose opposite sides and angles are equal, but which is neither equilateral nor equiangular.

**RHOMBOIDES**, in anatomy, a thin, broad, and obliquely square fleshy muscle, situated between the basis of the scapula and the spina dorsi, so called from its figure. Its general use is to draw backward and upward the subspinal portion of the basis scapule.

**RHOMBUS**, in geometry, an oblique-angled parallelogram, or quadrilateral figure whose sides are equal and parallel, but the angles unequal, two of the opposite ones being obtuse and two acute.

**RHONE**, an important river of the south of Europe, rising in the central and highest part of Switzerland, at the foot of Mount Furca, and about five miles from the source of the Rhine. It flows in a western direction through the Swiss canton of the Valais, here called the valley of the Rhone, after which, swelled by numerous mountain streams, its turbid waters mingle with those of the lake of Geneva. Issuing in a purer stream, the Rhone now flows southward, and forms the boundary between France and Savoy, until approaching Chambery, it turns to the west and north, and, reaching Lyons, is joined by the Saone, a river of equal length of course, but of less copious stream. From Lyons the Rhone holds a south course, all the way to the Mediterranean, receiving a number of streams east and west : the largest of these are the Isere and Durance. After a course of nearly 500 miles, the Rhone discharges itself, by three mouths, into the gulf of Lyons. It is the most rapid river in Europe : between Geneva and Lyons its channel in some parts is extremely narrowed by rocks, and at one place, about sixteen miles below Geneva, it loses itself underground for the space of sixty paces. Though not so long in its course as the Loire, it exceeds it and all the other rivers in France in size. The navigation down the stream takes place with great ease ; the upward can be performed only by draught or steam. It deposits so large a quantity of earth at its mouth that a light-house, built on the shore in 1737, is now three miles distant from it.

**RHONE**, a department of France, including the former provinces of Beaujalois and Lyonnais, and bounded by those of the Saone and Loire, the Ain, the Isere, and the Loire. It has a superficial extent of 1050 square miles, somewhat mountainous, and, owing to the vicinity of the Alps, the climate is more inclined to cold than heat. But the southern part, along the Rhone, furnishes excellent fruit, and wine, called from the exposure of many of the vineyards, *cote-rotie*. North-east part, along the borders of the Saone, there are extensive meadows ; and in the central part corn is produced. The inhabitants of the mountainous districts are employed in spinning and weaving of cotton. The manufactures, particularly in Lyons and its vicinity, are

extensive. This department belongs to the diocese and jurisdiction of the royal court of Lyons, and is divided into two arrondissements, Lyons the capital, and Villefranche. Inhabitants 330,000.

**RHONE, MOUTHS OF THE, Bouches du Rhone**, a department of France, formed of a part of Provence, and bounded by the Mediterranean and the departments of the Gard, the Vaucluse, and the Var. Its superficial extent is about 2000 square miles, traversed by a branch of the Alps, and for the most part an undulating plain, watered by the Rhone, the Durance, and other rivers. The climate is mild, producing wine, fruit, olives, soda, sumach, and silk-worms ; along the coast are made quantities of salt. The wine made, though large in quantity, is used chiefly for home consumption. The culture of the olive was formerly extensive ; but the winter of 1788 and 1789 destroyed a vast number of trees, and reduced the produce of the department to a fourth of its former amount. Silk is exported annually to the amount of £40,000, and wool to the value of £30,000. The department has pasture for sheep, but little for large cattle. Butter is almost unknown ; there is likewise a deficiency of wood, and of corn. It belongs to the diocese and jurisdiction of the royal court of Aix ; and is divided into the arrondissements, viz. Marseilles the capital, Aix, and Tarascon. Population 293,000.

**RHOPIUM**, in botany, a genus of the triandria order and gynandria class of plants : *cal.* monophyllous and *sexpartite* : *cor.* none, and no stamina ; the three antheræ are each attached to one of the styli : *caps.* trilocular and *sexlocular*, each cell containing two seeds. Species one only, viz. *R. meborea*, a native of Guiana. This is a shrub rising about three or four feet in height. The flowers grow in the form of a corymbus ; they are of a yellowish-green color ; the capsules are black.

**RHOPOLA**, in botany, a genus of the monogynia order and tetandria class of plants : *cal.* none ; petals four, oblong, obtuse, and narrowing at the base ; stamina four, inserted in the corolla, and having large antheræ ; unilocular, and containing one seed. There is only one species, viz. *R. montana*, a shrubby plant growing in Guiana, and remarkable for the great number of branches sent off from its trunk in every direction, and for the fetid smell of its wood and bark.

**RHOTAS**, an extensive district of Hindostan, province of Bahar. It is chiefly situated between the rivers Soane and Caramassa. The southern part is hilly and covered with wood ; but the northern parts level, well watered, and fertile. The principal towns are Sassaram, Serris, Bogwanpore, and Rhotas.

**RHOTAS**, a fortress of Hindostan, the capital of the district of this name, province of Punjab. It is situated on the western side of the Jhylum or Hydaspes, and is said to be very strong ; it has not been visited by any European, but was seen at a distance by Mr. Elphinstone, in the year 1809. Long. 72° 55' E., lat. 31° 55' N.

**RHOTAS, OR ROTASGAR**, a celebrated fortress of Hindostan, in Bahar, on the top of a table

mountain. The only entrance is a very narrow road, cut through a steep ascent of two miles, and defended by three gates at a distance from each other. The edge of the mountain is surrounded by a parapet, at the back of which are collected heaps of stones, for the purpose of rolling down on the assailants. The surface is ten miles square, containing a town, and several reservoirs of water, to irrigate the fields, were it requisite; but, as the climate is considered unhealthy, they are abandoned, and the fortifications are falling to decay.

**RHOTENAMER** (John), an eminent Italian painter, born in 1564. He studied after Tintoret, and settled at Venice. His works are remarkable for brilliant coloring and high finishing.

**RHOXALANI**, an ancient nation who resided on the north bank of the Palus Mæotis, between Europe and Asia, on the confines of both.

**RHU'BARB**, *n. s.* Lat. *rhabarbara*. A medicinal root, referred by botanists to the dock.

What *rhubarb*, senna, or what purgative drug  
Would scour these English hence? *Shakspeare.*  
Having fixed the fontanel, I purged him with an  
infusion of *rhubarb* in small ale. *Wiseman.*

**RHUBARB**. See **RHEUM**.

**RHUMB**, in navigation, a vertical circle of any given place, or intersection of such a circle with the horizon; in which last sense rhumb is the same with a point of the compass.

**RHUMB LINE**, the line which a ship describes when sailing in the same collateral point of the compass, or oblique to the meridians.

**RHUNKEN**, or **RHUNKENIUS** (David), a celebrated German critic, was born at Stolpen in Pomerania, in 1723. Intended for the clerical profession, he passed some time at the university of Königsberg, devoting himself to classical literature; he then removed to Wittemberg, where he took the degree of LL. D., and afterwards to Leyden, where Hemsterhuis procured him the situation of a tutor, and through his advice he published an edition of the Greek Lexicon of Timæus. He subsequently went to Paris, and in 1757 became assistant to Hemsterhuis at Leyden: and in 1761 he succeeded Oudendorp as professor of Latin and of history. He died much regretted in 1798. His chief works are a eulogium on his friend Hemsterhuis; an edition of Rutilius Lupus on Rhetoric; and of the history of Velleius Paterculus.

**RHUS**, sumach, in botany, a genus of the trigynia order and pentandria class of plants; natural order forty-third, dumosæ: CAL. quinquepartite; petals five; berry monospermous. Species thirty-five, of which the most remarkable are,

1. **R. Canadensis**, with winged spear-shaped leaves, grows naturally in Canada, Maryland, and several other parts of North America. It has smooth branches of a purple color, covered with a gray pounce. The leaves are composed of seven or eight pairs of lobes, terminated by an odd one; the lobes are spear-shaped, sawed on their edges, of a lucid green on their upper surface, but hoary on their under, and are smooth. The flowers are produced at the end of the branches in large panicles, composed of

several smaller, each standing upon separate foot-stalks; they are of a deep red color, and the whole panicle is covered with a gray powder.

2. **R. Carolinianum**, with winged leaves grows naturally in Carolina. This is by the gardeners called the scarlet Carolina sumach; it rises commonly to the height of seven or eight feet, dividing into many irregular branches, which are smooth, of a purple red color, and covered over with a grayish powder, as are also the foot-stalks of the leaves. The leaves are composed of seven or eight pairs of lobes, terminated by an odd one; these are not always placed exactly opposite on the midrib, but are sometimes alternate. The upper side of the lobes is of a dark green, and their under hoary but smooth. The flowers are produced at the end of the branches in very close panicles, which are large and of a bright red color.

3. **R. copallinum**, the narrow leaved sumach, grows naturally in most parts of North America, where it is called beach sumach, probably from the place where it grows. This is of humble growth, seldom rising above four or five feet high in Britain, dividing into many spreading branches, which are smooth, of a light brown color, closely garnished with winged leaves, composed of four or five pairs of narrow lobes, terminated by an odd one; they are of a light green on both sides, and in autumn change to purplish. The mid rib, which sustains the lobes, has on each side a winged or leafy border, which runs from one pair of lobes to another, ending in joints at each pair, by which it is easily distinguished from the other sorts. The flowers are produced in loose panicles at the end of the branches, of a yellowish herbaceous color. The resin called gum copal is produced from this shrub. See **COPAL**.

4. **R. coriaria**, the elm leaved sumach, grows naturally in Italy, Spain, Turkey, Syria, and Palestine. The branches are used instead of oak bark for tanning of leather; and it is said that the Turkey leather is all tanned with this shrub. It has a ligneous stalk, which divides at bottom into many irregular branches, rising eight or ten feet; the bark is hairy, of an herbaceous brown color; the leaves are winged, composed of seven or eight pairs of lobes, terminated by an odd one, bluntly sawed on their edges, hairy on their under side, of a yellowish green color, and placed alternately on the branches: the flowers grow in loose panicles on the end of the branches, which are of a whitish herbaceous color, each panicle being composed of several spikes of flowers sitting close to the foot-stalks. The leaves and seeds are used in medicine, and esteemed very astringent and styptic.

5. **R. typhinum**, Virginian sumach, or vinegar plant, grows naturally in almost every part of North America. It has a woody stem, with many irregular branches, which are generally crooked and deformed. The young branches are covered with a soft velvet-like down, resembling greatly that of a young stag's horn, both in color and texture, whence it has the appellation of stag's horn; the leaves are winged, composed of six or seven pairs of oblong heart-shaped lobes, terminated by an odd one, ending in acute

points, hairy on their under side, as is also the mid rib. The flowers are produced in close tufts at the ends of the branches, and are succeeded by seeds, enclosed in purple woolly succulent covers; so that the bunches are of a beautiful purple color in autumn; and the leaves, in autumn, change to a purplish color at first, and before they fall to feuillemort. This plant has been long cultivated in the north of Germany, and is lately introduced into Russia. It has obtained the name of the vinegar plant from the double reason of the young germen of its fruit, when fermented, producing either new, or adding to the strength of old weak vinegar, whilst its ripe berries afford an agreeable acid, which might supply the place, when necessary, of the citric acid. The powerful astringency of this plant in all its parts recommends it as useful in several of the arts. The ripe berries boiled with alum make a good dye for hats. The plant in all its parts may be used as a succedaneum for oak bark in tanning, especially for the white glove leather. It will likewise answer to prepare a dye for black, green, and yellow colors; and with martial vitriol it makes a good ink. The milky juice that flows from incisions made in the trunk of branches, makes, when dried, the basis of a varnish little inferior to the Chinese. Bees are remarkably fond of its flowers; and it affords more honey than any of the flowering shrubs. The natives of America use the dried leaves as tobacco.

These five species of rhus are hardy plants, and will thrive in the open air here. The second and fourth sorts are not quite so hardy as the others, so must have a better situation, otherwise their branches will be injured by severe frost in the winter. They are easily propagated by seeds, which if sown in autumn the plants will come up the following spring; but, if sown in spring, they will not come up till the next spring; they may be either sown in pots or the full ground. If they are sown in pots, in autumn, the pots should be placed under a common frame in winter, where the seeds may be protected from hard frost; and in spring, if the pots are plunged into a very moderate hot-bed, the plants will soon rise, and have thereby more time to get strength before winter. When the plants come up they must be gradually hardened to bear the open air, into which they should be removed as soon as the weather is favorable, placing them where they may have the morning sun; in the summer they must be kept clean from weeds, and in dry weather watered. Toward autumn it will be proper to stint their growth by keeping them dry, that the extremity of their shoots may harden; for, if they are replete with moisture, the early frosts in autumn will pinch them, which will cause their shoots to decay almost to the bottom if the plants are not screened from them. If the pots are put under a common frame in autumn it will secure the plants from injury; for, while they are young, and the shoots soft, they will be in danger of suffering, if the winter prove very severe; but in mild weather they must always enjoy the open air, therefore should never be covered but in frost. The spring following, just before the plants begin to shoot, they should be shaken out

of the pots, and carefully separated, so as not to tear the roots; and transplanted into a nursery, in rows three feet asunder, and one foot distance in the rows. In this nursery they may stand two years to get strength, and then may be transplanted where they are to remain.

6. *R. vernix*, the toxicodendron, poison tree, or poison ash grows naturally in Virginia, Pennsylvania, New England, Carolina, and Japan, rising with a strong woody stalk to the height of twenty feet and upwards; though in this country it is seldom seen above twelve, the plants being extremely tender. The bark is brown, inclining to gray; the branches are garnished with winged leaves composed of three or four pairs of lobes terminated by an odd one. The lobes vary greatly in their shape, but for the most part they are oval and spear-shaped. The foot-stalks become of a bright purple towards the latter part of summer, and in autumn all the leaves are of a beautiful purple before they fall off. All the species of sumach abound with an acrid milky juice, which is reckoned poisonous; but this property is most remarkable in the vernix. The most distinct account of it is to be found in professor Kalm's Travels in North America. 'An incision,' says he, 'being made into the tree, a whitish yellow juice, which has a nauseous smell, comes out between the bark and the wood. The tree is not known for its good qualities, but greatly so for the effect of its poison; which, though it is noxious to some people, yet does not in the least affect others. And therefore one person can handle the tree as he pleases, cut it, peel off its bark, rub it or the wood upon his hands, smell at it, spread the juice upon his skin, with no inconvenience to himself: another dares not meddle with the tree while its wood is fresh; nor can he venture to touch a hand which has handled it, nor even to expose himself to the smoke of a fire made with this wood, without soon feeling its bad effects; for the face, the hands, and frequently the whole body, swell excessively, and are affected with a very acute pain. Sometimes bladders or blisters arise in great plenty, and make the sick person look as if infected by a leprosy. In some people the cuticle peels off in a few days, as when a person has scalded or burnt any part of his body. The leaves of this tree have been used medicinally in paralysis and herpetic affections. Dr. Fresnoi was the first who attempted its use in these diseases; and, in order that others should not suffer by his experiments, he began upon himself by taking an infusion of one of the three leaflets of which each leaf consists; and as this dose produced no sensible effect, he increased the number to twelve. His urine and perspiration were increased in quantity, and he had some pains in his belly. He relates seven cases, in which he cured herpetic disorders, and five of paralysis. The natives distinguish this tree in the dark by its extreme coldness to the touch. The juice of some kinds of sumach, when exposed to the heat of the sun, becomes so thick and clammy that it is used for bird lime, and the inspissated juice of the poison ash is said to be the fine varnish of Japan. A cataplasm made with the fresh juice of the poison ash, ap-



plied to the feet, is said to kill the vermin called by the West Indians chigers.

RHYME, *n. s.* } Fr. *rhythme* ; Gr. *ρυθμος*.  
 RHY'MER, } An harmonical succession  
 RHYM'STER, } of sounds, particularly at  
 RHYTH'MICAL, *adj.* } the close of lines or  
 verses ; poetry ; the rhyming word ; to agree or  
 harmonize in sound : make verses : a rhymers, one  
 who makes them ; rhythmical is, harmonious.

All his manly power it did disperse,  
 As he were warmed with enchanted *rhymes*,  
 That oftentimes he quaked. *Faerie Queene.*

I was promised on a time,  
 To have reason for my *rhyme* ;  
 But from that time unto this season,  
 I had neither *rhyme* nor reason. *Spenser.*  
 Scall'd *rhymers* will ballad us out o' tune. *Shakespeare.*

The guiltiness of my mind drove the grossness of  
 the foppery into a received belief, in despite of the  
 teeth of all *rhyme* and reason, that they were fairies.

*Id.*  
 It was made penal to the English to permit the  
 Irish to graze upon their lands, to entertain any of  
 their minstrels, *rhimers*, or news-tellers.

*Davies on Ireland.*  
 The youth with songs and *rhimes* :  
 Some dance, some hale the rope. *Denham.*  
 Who would not sing for Lycidas ? he knew  
 Himself to sing, and build the lofty *rhyme*. *Milton.*  
 For *rhyme* the rudder is of verses,  
 With which like ships they steer their courses.

*Hudibras.*  
 He was too warm on picking work to dwell,  
 But fagotted his notions as they fell,  
 And, if they *rhimed* and rattled, all was well. *Dryden.*

Milton's *rhime* is constrained at an age, when the  
 passion of love makes every man a *rhimer* though  
 not a poet. *Id.*

Now sportive youth,  
 Carol incondite *rhythms* with suiting notes,  
 And quaver inharmonious. *Philips.*

If Cupid throws a single dart,  
 We make him wound the lover's heart ;  
 But, if he takes his bow and quiver,  
 'Tis sure he must transfix the liver ;  
 For *rhime* with reason may dispense,  
 And sound has right to govern sense. *Prior.*

I speak of those who are only *rhimsters*. *Dennis.*  
 There marched the bard and blockhead side by  
 side,

Who *rhymed* for hire, and patronized for pride. *Pope.*

What wise means to gain it hast thou chose ?  
 Know, fame and fortune both are made of prose.  
 Is thy ambition sweating for a *rhyme*,  
 Thou unambitious fool, at this late time ? *Young.*

RHYMER (Thomas the), was a native of the  
 parish of Earlstown in Berwickshire. His real  
 name and title were Sir Thomas Learmouth.  
 He lived at the west end of Earlstown in the  
 thirteenth century, and was contemporary with  
 one of the earls of March, who lived in the same  
 place.

RIAL, or RYAL. See COINS.

RIAZAN, a large province of European Rus-  
 sia, lying to the south of the government of Vla-  
 dimir, and to the east of that of Moscow, extend-  
 ing from lat. 53° 40' to 55° 0' N., and from long.  
 36° 25' to 41° 45' E. Its area is above 13,000 square  
 miles, and level country, with a few elevations.

The north contains a number of woods and  
 marshes, but the rest of the country produces  
 wheat, oats, barley, and other corn ; hemp and  
 flax. The number of cattle is rather below the  
 average proportion in Russia, but the breed of  
 horses is good, and great attention is paid to  
 bees. Woollen and linen are made for domestic  
 use, and a few iron, glass, and leather articles  
 for export. The imports are also very lim-  
 ited, the only one of importance being salt.  
 In former times an independent duchy, this  
 government became a province of the empire,  
 under the name of Pereslavl-Riasanskoï, and re-  
 ceived its present name from Catherine II. It  
 is divided into twelve circles. Population  
 1,000,000.

RIAZAN, the capital of the above government,  
 is situated on the Oka, 123 miles S. S. E. of  
 Moscow. It is the see of a Greek bishop, and  
 has an unusual number of churches. The epis-  
 copal palace was formerly that of the dukes ; but  
 the best building of the town is that for the go-  
 vernment offices and courts of justice. Here are  
 manufactures of iron, linen, woollen, leather  
 needles, and glass ; but the town is small. In-  
 habitants 5000. It is one of the most ancient  
 towns of Russia.

RIB, *n. s. & v. a.* Sax. *rubbe* ; Dan. *Swed.*  
 and Belg. *rib* ; Teut. *ribbe* ; Goth. *rif*. A bone  
 in the side of the body ; a side timber of a ship :  
 to furnish with ribs.

Was I by rocks engendered ; *ribbed* with steel ;  
 Such tortures to resist, or not to feel ? *Sundys.*

Why do I yield to that suggestion,  
 Whose horrid image doth unfix my hair,  
 And make my seated heart knock at my ribs,  
 Against the use of nature ! *Shakespeare. Macbeth.*

Remember  
 The nat'ral brav'ry of your isle, which stands  
 As Neptune's park, *ribbed* and paled in  
 With rocks unscaleable, and roaring waters.

*Shakespeare.*  
 The ships with shatter'd *ribs* scarce creeping from  
 the seas. *Drayton.*

It was a happy change to Adam, of a *rib* for a  
 helper. *Bp. Hall.*

He opened my left side, and took  
 From thence a *rib*, with cordial spirits warm  
 And life-blood streaming fresh. *Milton.*

Sure he, who first the passage tried,  
 In hardened oak his heart did hide,  
 And *ribs* of iron armed his side. *Dryden.*

The *ribs* are of two sorts ; the seven upper are  
 called true *ribs*, because their cartilaginous ends are  
 received into the sinus of the sternum : the five lower  
 are called false *ribs*, because they are softer and  
 shorter, of which only the first is joined to the ex-  
 tremity of the sternum, the cartilaginous extremities  
 of the rest being tied to one another, and thereby  
 leaving a greater space for the dilatation of the sto-  
 mach and entrails : the last of these short *ribs* is  
 shorter than all the rest ; it is not tied to them, but  
 sometimes to the musculus obliquus descendens.

*Quincy.*  
 Hung on each bough a single leaf appears,  
 Which shrivelled in its infancy remains,  
 Like a closed fan, nor stretches wide its veins,  
 But, as the seasons in their circle run,  
 Opens its *ribbed* surface to the nearer sun. *Gay.*  
 At thy firmest age  
 Thou hadst within thy bole solid contents,

That might have *ribbed* the sides and planked the deck  
Of some flagged admiral. *Cowper.*

RIBS. See ANATOMY.

RIBADENEIRA (P'ter), a Spanish Jesuit, born in 1527. He wrote with purity of style in his native tongue. His most valuable work is his Account of the writers among the Jesuits. He died at Madrid in 1611, aged eighty-four.

RIB'ALD, n. s. } Fr. *ribauld*; Ital. *ribaldo*;

RIB'ALDRY. } Goth. *ribaulder* means a camp follower. A loose, mean, or brutal wretch: ribaldry is the talk of such wretches.

That lewd *ribald*, with vile lust advanced,  
Laid first his filthy hands on virgin clean,  
To spoil her dainty corse so fair and sheen.

*Spenser.*

You *ribauld* nag of Egypt,

The breeze upon her, like a cow in June,

Hoists sails, and flies. *Shakespeare.*

Mr. Cowley asserts that obscenity has no place in wit; Buckingham says, 'tis an ill sort of wit which has nothing more to support it than barefaced *ribaldry*. *Dryden.*

In the same antique loom these scenes were wrought,

Embellished with good morals and just thought,

True nature in her noblest light you see,

Ere yet debauched by modern gallantry

To trifling jests and fulsome *ribaldry*. *Granville.*

Ne'er one sprig of laurel graced these *ribalds*,

From slashing Bentley down to piddling Tibbalds.

*Pope.*

If the outward profession of religion were once in practice among men in office, the clergy would see their duty and interest in qualifying themselves for lay-conversation, when once they were out of fear of being choaked by *ribaldry* or profaneness. *Swift.*

RIB'AND, n. s. Fr. *rubande*, *ruban*. Generally now written ribbon. A fillet of silk, worn for ornament.

Quaint in green, she shall be loose enrobed,  
With *ribbands* pendant, flaring 'bout her head.

*Shakespeare.*

A *ribband* did the braided tresses bind,

The rest was loose. *Dryden's Knight's Tale.*

See! in the list they wait the trumpet's sound;

Some love device is wrought in ev'ry sword,

And ev'ry *ribband* bears some mystick word.

*Granville.*

No dimness of eye, and no cheek hanging low,

No wrinkle, or deep-furrowed frown on the brow!

Her forehead indeed is here circled around

With locks like the *ribband* with which they are bound. *Cowper.*

So playful love on Ida's flowery sides

With *riband-roses* the indignant lion guides:

Pleased on his brindled back the lyre he rings,

And shakes delirious rapture from the strings.

*Darwin.*

RIBAND-MAKING. See SILK MANUFACTURE.

RIBERA, a Spanish poet, called the Scarron of Spain, from the humor and ludicrous scenes with which his writings abound. His works were published at Madrid, in 1648.

RIBES, the currant and gooseberry tree, a genus of the monogynia order and pentandria class of plants; natural order thirty-sixth, pomaceæ. There are five petals, and stamina inserted into the calyx; the style is bifid; the berry polyspermous, inferior. The currant and gooseberry were long considered each as a separate genus: *ribes* the currant, and *grossularia* the

gooseberry; but they are now joined together, the *grossularia* being made a species of *ribes*; all the currant kinds having inermous or thornless branches, and racemous clusters of flowers and fruit; and the gooseberry spinous branches, and flowers and fruit for the most part singly.

1. *R. cynosbati*, the prickly fruited gooseberry tree, has a shrubby stem and branches armed with spines, mostly at the axillas, and prickly fruit in clusters.

2. *R. grossularia*, the common gooseberry tree, rises with a low shrubby stem, dividing low into a very branchy bushy head, armed with spines; trilobate smallish leaves, having hairy ciliated foot-stalks, and small greenish flowers, succeeded by hairy berries. It consists of many varieties of different sizes and colors.

3. *R. nigra*, the black currant tree, has a shrubby stem dividing low into many branches, forming a bushy head five or six feet high; broad trilobate leaves of a strong smell, and having racemose clusters of oblong greenish flowers, succeeded by thin clusters of blackberries. The fruit of this species being of a strong flavor is not generally liked; it is, however, accounted very wholesome: there is also made of it a syrup of high estimation for sore throats and quinsies. There is a variety called the Pennsylvania black currant, having smaller shoots and leaves, not scented, and small fruit, but of little value; the shrub is esteemed only for variety and shrubberies. All the varieties of currants bear fruit both in old and young wood all along the sides of the branches and shoots, often upon a sort of small sprigs and snags, the berries hanging in numerous long pendulous clusters.

4. *R. reclinata*, the reclined broad-leaved gooseberry tree, rises with a low shrubby stem, and reclinated somewhat prickly branches, trilobate broadish leaves, and small greenish flowers, having the pedunculi furnished with triphyllous bractea.

5. *R. rubra*, common red currant tree, &c., has a shrubby stem, dividing low into many branches, forming a bushy head, five or six feet high or more, without thorns; broad trilobate leaves, and smooth pendulous clusters of plane greenish flowers, succeeded by small clusters of berries. It grows naturally in woods and hedges in most parts of Europe, and comprises all sorts of red and white currants; as, common small red currant—large bunched red currant—Champagne pale red currant—common small white currant—large white Dutch currant—yellow blotched leaved currant—silver striped leaved—gold striped leaved—gooseberry leaved. All these sorts are varieties of the common red currant; it being the parent from which all the others were first obtained from the seed, and improved by culture. They all flower in the spring, and the fruit ripens in June and July, and by having the trees in different situations and modes of training, such as plantations of standard in the open quarters for the general supply, others trained against walls or pales of different aspects, the fruit may be continued ripe in perfection from about the middle of June until November, provided the later crops are defended with mats or nets from the birds.

6. *R. uva crisa*, the smooth gooseberry, has a shrubby stem, and branches armed with spines; trilobate leaves; pedicles having monophyllous bractea, and smooth fruit. All the above species, both currant and gooseberry kinds, and their respective varieties, are very hardy shrubs, that prosper almost any where, both in open and shady situations, and in any common soil; bearing plentifully in any exposure, though in open and sunny situations they produce the largest and fairest fruit, ripening to a rich vinous flavor. It is eligible to plant them in different situations and aspects, to have the fruit as early and late as possible. They are commonly planted in the kitchen garden as dwarf standards, in open quarters; sometimes in rows, eight or ten feet by six asunder, and sometimes in single ranges round the outward edge of the quarters, eight feet asunder; often in single cross rows; in all of which methods they should be trained up to a single stem a foot high, then suffered to branch out all around into bushy heads, keeping the middle open, and the branches moderately thin, to admit the sun and free air. They are likewise trained against walls or palings, like other wall trees, when they will produce fine large fruit; but it is proper to plant a few both against south, north, east, and west walls, to obtain the fruit ripe both early and late. Both currants and gooseberries are of an acid and cooling nature, and as such are sometimes used in medicine, especially the juice reduced to a jelly by boiling with sugar. From the juice of currants also wine is made.

**RIB'ROAST**, *v. a.* Rib and roast. To beat soundly. A burlesque word.

That done, he rises, humbly bows,  
And gives thanks for the princely bows;  
Departs not meanly proud, and boasting  
Of his magnificent *ribrasting*.

*Butler.*

I have been pinched in flesh, and well *ribrasted*  
under my former masters; but I'm in now for skin  
and all. *L'Étrange.*

**RICARDO** (David), M. P. and F. R. S., the late celebrated writer on political economy, was of Jewish extraction, and born in London, April 12th, 1772. His father was a Dutch Jewish stockbroker; and the son was early sent to Holland for education. He offended his friends while young, it is said, by uniting himself in marriage with Miss Wilkinson, a quakeress, and was thus, with few resources, left to achieve his own fortune. He soon however established a character for probity and talent; and, becoming a member of the Stock Exchange, gradually accumulated a large property. In 1810 he appeared as a writer in the *Morning Chronicle*, on the subject of the depreciation of the currency; and afterwards embodied his ideas in a distinct work, the leading ideas of which he had the satisfaction to see adopted and confirmed in the Report of the Bullion Committee. He now published *An Essay on Rent*, in which he advocated the Malthusian principles, concerning population; he also entered on an examination of the affairs of the Bank of England, and suggested a plan for an economical currency. But his most important production was his treatise on *Political Economy and Taxation*, which has been ranked by Mi

M'Culloch and other writers with the celebrated work of Dr. Adam Smith. See our article *POLITICAL ECONOMY*. In 1819 Mr. Ricardo obtained a seat in parliament for the borough of Portarlington, and displayed as a senator that sound good sense which generally distinguishes his published works. He died of inflammation of the brain, arising from an abscess in the ear, at his seat, Gatcomb Park, near Minchin Hampton in Gloucestershire, September 11th, 1823. Mr. Ricardo is said to have adopted the religious principles of Unitarianism, but usually attended the established church. We have, on the other hand, heard from a near connexion of Mr. Ricardo's that he suggested, among other improvements, a sort of intermediate faith between Judaism and Christianity; holding that Jesus Christ was a worthy man and an excellent teacher, whose precepts should therefore be regarded with great respect; but that 'he assumed too much' in his pretension to be the son of God: and therefore that the blame of his unhappy catastrophe was to be divided between his enemies and himself.

**RICAUT**, or **RYCAUT** (Sir Paul), an eminent English traveller, of the date of whose birth we find no account; but in 1661 he was appointed secretary to the earl of Winchelsea, who was sent ambassador extraordinary to the Ottoman Porte. During his continuance in that station, he wrote, *The present State of the Ottoman Empire*, in 3 books: London, fol. 1670. He afterwards resided eleven years as consul at Smyrna, where, by order of Charles II., he composed *The present state of the Greek and Armenian Churches*, anno Christi 1678. On his return, lord Clarendon, being appointed lord-lieutenant of Ireland, made him his principal secretary for Leinster and Connaught; James II. knighted him, and made him one of the privy council in Ireland, and judge of the court of admiralty; all which he held to the Revolution. He was employed by king William as resident at the Hanse Towns in Lower Saxony, where he continued ten years; but, being worn out with age and infirmities, he obtained leave to return in 1700, and died the same year. He continued Knolles's *History of the Turks*, and also Platina's *Lives of the Popes*.

**RICCATI** (Vincent), a celebrated Italian Jesuit, born at Castel Franco, in the Trevisan, in 1707. He became a professor of mathematics at Bologna; and published a learned work on the *Integral Calculus*, in 3 vols. 4to. He died in 1775, aged sixty-eight.

**RICCI** (Laurence), a learned Italian Jesuit, born in Florence, in 1703, of a distinguished family. He was chosen general of the order in 1758, but had the misfortune to be the last person who ever held that office; as the order was abolished in 1773. Ricci and some others were immediately sent to the castle of St. Angelo in Rome, where he died in 1775.

**RICCI** (Matthew), another learned Italian Jesuit, born at Macerata, in 1552. He went to the East Indies when young, and was sent as a missionary to China, where he acquired the Chinese language, and was favored by the emperor so much that he was allowed to build a church at Peking. He died in that city in 1610; and left

some curious Memoirs respecting China behind him.

**RICCI** (Sebastian), an eminent Italian painter, born at Belluno, in 1659. The imperial court employed him to adorn the palace of Schoenbrunn; after which he came to London, where he was much employed, and amassed money: but he returned to Venice, where he died in 1734. Mark Ricci his nephew was also eminent in painting history, architecture, and landscapes. He died in 1730.

**RICCIA**, in botany, marsh liverwort, a genus of the natural order of algæ, and cryptogamia class of plants: *cal.* none, but a vesicular cavity within the substance of the leaf: *cor.* none: the antheræ are cylindrical, and sessile, placed on the germen, which is turbinated; the style is filiform, perforating the anthera; and the seed case is spherical, crowned with the withered antheræ; the *SEEDS* are hemispherical and pedicelled. Species eleven, five of which are indigenous to our own country.

**RICCOBONI** (Lewis), an Italian dramatic writer, and actor, born at Modena, in 1677. He wrote several comedies; besides a work entitled *Reflexions Historiques et Critiques sur les Theatres de L'Europe*; 1738, 8vo. He died in 1753, aged seventy-six.

**RICE**, *n. s.* Lat. *oryza*; Gr. *ορυζα*; Sans. *riz*; Arab. *urooz*. One of the esculent grains, cultivated in most eastern countries.

*Rice* is the food of two-thirds of mankind; it is kindly to human constitutions, proper for the consumptive, and those subject to hæmorrhages.

If the snuff get out of the snuffers, it may fall into a dish of *ri* & milk. *Arbuthnot.*  
*Swift.*

**RICE**. See **ORYZA**. This plant is cultivated in many parts of the east, in South Carolina, in America, and also in Spain, Italy and Piedmont. It is a plant that grows to the height of about two feet and a half, with a stalk not unlike that of wheat, but fuller of joints, and with leaves resembling that of the leek. It branches out into several stems, at the top of which the grain grows in clusters, and each of them is terminated with an ear or beard, and enclosed in a yellow rough husk. When stripped of this, they appear to be of an oval shape, of a shining white color, and almost transparent. It is probably a plant that cannot be reared in this climate. The following is the Chinese method of cultivating it:—  
\* Much of the low grounds in the middle and southern provinces of the empire is appropriated to the culture of this grain. It constitutes, in fact, the principal part of the food of the inhabitants. A great portion of the surface of the country is well adapted for the production of rice, which, from the time the seed is committed to the soil till the plant approaches to maturity, requires to be immersed in a sheet of water. Many and great rivers run through the several provinces of China: the low grounds bordering on those rivers are annually inundated, by which means a rich mud or mucilage is brought upon their surface that fertilises the soil. The periodical rains which fall near the sources of the Yellow and the Kiang Rivers, not very far distant from those of the Ganges and the Burum-

pooter, among the mountains bounding India to the north, and China to the west, often swell those rivers to a prodigious height, though not a drop of rain should have fallen on the plains through which they afterwards flow. After the mud has lain some days upon the plains in China preparations are made for planting them with rice. For this purpose, a small spot of ground is enclosed by a bank of clay; the earth is ploughed up; and an upright harrow, with a row of wooden pins in the lower end, is drawn lightly over it by a buffalo. The grain, which had previously been steeped in dung diluted with animal water is then sown very thickly on it. A thin sheet of water is immediately brought over it, either by channels leading to the spot from a source above it, or when below it by means of a chain pump, of which the use is as familiar as that of a hoe to every Chinese husbandman. In a few days the shoots appear above the water. In that interval, the remainder of the ground intended for cultivation, if stiff, is ploughed, the lumps broken by hoes, and the surface levelled by the harrow. As soon as the shoots have attained the height of six or seven inches, they are plucked up by the roots, the tops of the blades cut off, and each root is planted separately, sometimes in small furrows turned with the plough, and sometimes in holes made in rows by a drilling stick for that purpose. The roots are about six inches asunder. Water is brought over them a second time. For the convenience of irrigation, and to regulate its proportion, the rice fields are subdivided by narrow ridges of clay, into small enclosures. Through a channel, in each ridge, the water is conveyed at will to every subdivision of the field. As the rice approaches to maturity, the water by evaporation and absorption disappears entirely; and the ripe crop covers dry ground. The first crop or harvest, in the southern provinces particularly, happens towards the end of May or beginning of June. The instrument for reaping is a small sickle, dentated like a saw, and crooked. Neither carts nor cattle are used to carry the sheaves off from the spot where they are reaped; but they are placed regularly in frames, two of which, suspended at the extremities of a bamboo pole, are carried across the shoulders of a man, to the place intended for disengaging the grain from the stems which had supported it. This operation is performed, not only by a flail, as is customary in Europe, or by cattle treading the corn in the manner of Orientalists, but sometimes also by striking it against a plank set upon its edge, or beating it against the side of a large tub scolloped for that purpose; the back and sides being much higher than the front to prevent the grain from being dispersed. After being winnowed, it is carried to the granary. To remove the skin or husk of rice, a large strong earthen vessel, or hollow stone, in form somewhat like that which is used elsewhere for filtering water, is fixed firmly in the ground; and the grain placed in it is struck with a conical stone fixed to the extremity of a lever, and cleared, sometimes indeed imperfectly, from the husk. The stone is worked frequently by a person treading upon the end of the lever. The same object is attain-

also by passing the grain between two flat stones of a circular form, the upper of which turns round upon the other, but at such a distance from it as not to break the intermediate grain. The operation is performed on a large scale in mills turned by water; the axis of the wheel carrying several arms, which, by striking upon the ends of levers, raise them in the same manner as is done by treading on them. Sometimes twenty of these levers are worked at once. The straw from which the grain has been disengaged is cut chiefly into chaff, to serve as provender for the very few cattle employed in Chinese husbandry. The labor of the first crop being finished, the ground is immediately prepared for the reception of fresh seeds. The first operation undertaken is that of pulling up the stubble, collecting it into small heaps, which are burnt, and the ashes scattered upon the field. The former processes are afterwards renewed. The second crop is generally ripe late in October or early in November. The grain is treated as before; but the stubble is no longer burnt. It is turned under with the plough, and left to putrefy in the earth. This, with the slime brought upon the ground by inundation, is the only manure employed in the culture of rice.

**RICH**, *adj.* Fr. *riche*; Ital. *ricco*; Sax. **RICH'ED**, *n. s.* } *rica*. Ric is also a common northern affix, denoting rich, **RICH'LY**, *adv.* } as in Alaric, Frederic, &c. **RICH'NESS**. } Wealthy; abounding in money or possessions; opulent; plentiful: all the derivatives corresponding.

The rich shall not give more, and the poor no less.

*Exodus.*

Of virtue you have left proof to the world;  
And virtue is grateful with beauty and richness adorned.

*Sidney.*

I am as rich in having such a jewel,  
As twenty seas, if all their sand were pearl.

*Shakespeare.*

In Belmont is a lady richly left,  
And she is fair, of wondrous virtues.

*Id.*

Of all these bounds,  
With shadowy forests, and with champaigns riched,  
With plenteous rivers and wide skirted meads,  
We make thee lady.

*Id. King Lear.*

The instrumentalness of riches to charity has rendered it necessary by laws to secure propriety.

*Hammond.*

Women richly gay in gems

*Milton.*

Earth, in her rich attire,

Consummate lovely smiled.

*Id.*

Groves whose rich trees wept odorous gums and balm.

*Id.*

The gorgeous East with richest hand  
Pours on her sons barbaric pearl and gold.

*Id.*

In animals, some smells are found more richly than in plants.

*Bronn's Vulgar Errors.*

So we the Arabian coast do know  
At distance, when the spices blow,  
By the rich odour taught to steer,  
Though neither day nor star appear.

*Waller.*

Rich was his soul, though his attire was poor,  
As heaven had clothed his own ambassador.

*Dryden.*

The lively tincture of whose gushing blood  
Should clearly prove the richness of his food.

*Id.*

Several nations of the Americans are rich in land, and poor in all the comforts of life.

*Locke.*

Riches do not consist in having more gold and sil-

ver, but in having more in proportion than our neighbours, whereby we are enabled to procure to ourselves a greater plenty of the conveniences of life than comes within their reach, who, sharing the gold and silver of the world in less proportion, want the means of plenty and power, and so are poorer. *Id.*

There are who fondly studious of increase,  
Rich foreign mold on their ill-natured land  
Induce.

*Philips.*

Chemists seek riches by transmutation and the great elixir.

*Sprat.*

I amused myself with the richness and variety of colours in the western parts of heaven.

*Spectator.*

This town is famous for the richness of the soil.

*Addison.*

There is such licentiousness among the basest of the people, that one would not be sorry to see them bestowing upon one another a chastisement which they so richly deserve.

*Addison.*

If life be short, it shall be glorious,  
Each minute shall be rich in some great action.

*Rove.*

He may look upon the rich as benefactors, who have beautified the prospect all around him.

*Sead.*

What riches give us, let us first enquire;  
Meat, fire, and cloaths; what more? meat, cloaths, and fire.

*Pope.*

After a man has studied the laws of England, the reading the reports of adjudged cases will richly improve him.

*Watts.*

Matilda never was meanly dressed in her life; and nothing pleases her in dress but that which is very rich and beautiful to the eye.

*Law.*

Sauces and rich spices are fetched from India.

*Baker.*

Can all the wealth of India's coast

Atone for years in absence lost?

Return, ye moments of delight,  
With richer treasures bless my sight!

*Burns.*

**RICH** (John), a pantomimic actor of the last century, attracted general admiration in his youth by the performance of Harlequin. In expressing the feelings of the mind by dumb show, his power was inimitable, and superseded much of the necessity of vocal language. He rendered pantomime so fascinating that, with the assistance of an indifferent company, he secured a large share of the public attention, though opposed by the dramatic genius of Garrick. In 1733 he removed his company from Lincoln's-inn-fields to Covent Garden, where he was manager till his death, in December 1761, during the run of a grand spectacle. His education had been so neglected that he could neither write nor speak with common propriety. Among other peculiarities he had a habit of addressing persons to whom he was speaking, by the appellation of 'Mister,' and, on his applying this to Foote, the latter angrily asked him, why he could not call him by his name? 'Don't be offended,' Rich replied, 'I sometimes forget my own name.' 'Indeed!' said Foote, 'I knew you could not write your own name; but I could not have supposed you should forget it.'

**RICHARD OF CIRENCESTER**, thus named from his birth-place, was a Benedictine and an English historian of the fourteenth century. No traces remain of his history; except that he became a monk of the abbey of St. Peter, Westminster, in 1350, and that his name occurs in various documents of that monastery in 1387, 1397, and 1399. Towards the close of his life

he visited Rome; but returned to Westminster, and died there in 1401. He wrote *Historia ab Hengista ad an. 1348*, in two parts, still remaining a MS.; his principal work is a *Description of Britain*, first published in Latin at Copenhagen, in 1767, and more recently in Latin and English, with a commentary and maps by Mr. Hatcher, 1809, 8vo.

**RICHARD** (Louis Claude Marie), one of the most eminent modern botanists, was born at Versailles September 4th, 1754, and the son of the keeper of the royal gardens at Auteuil. He studied at the college of Vernon, and the Mazarin College, Paris. Here he partly supported himself by making drawings for architects, and at the same time assiduously applied himself to botany, anatomy, and zoology. While very young, he presented several memoirs to the Academy, which attracted the notice of Jussieu, who gave him the use of his library and cabinet. In 1781 he sailed from France on a voyage of research to French Guyana with the title of naturalist to the king, and returned in 1789, bringing with him a herbal of 1000 plants, most of which were newly discovered, beside other collections in natural history. During the political disturbances of the period his labors were neglected; but, when the school of medicine was established, he was appointed professor of botany; and, on the formation of the Institute, he was a member of the first class in the section of zoology. He was also a corresponding member of the Royal Society of London, and of the legion of honor. He died June 7th, 1821. The researches of Richard were chiefly directed to the comparative anatomy of plants, on which he published a number of valuable Memoirs, besides which he was the author of *Demonstrations Botaniques, ou Analyse du Fruit considéré en general*, 1803, 8vo.

**RICHARDIA**, in botany, a genus of the monogynia order, and hexandria class of plants; natural order forty-seventh, stellata: cal. sextipartite: cor. monopetalous, and subcylindrical; and there are three seeds. Species one only, a herb of Vera Cruz.

**RICHARDS** (Nathaniel), a dramatic writer in the reign of Charles I., and a fellow of Caius College, Cambridge, where he took his degree of A. B. in 1634. He wrote a tragedy entitled *Messalina*, published in 1640, which was acted with applause. He also wrote some poems, published in 1645.

**RICHARDSON** (Jonathan), a celebrated painter of heads, was born about 1665, and was placed by his father-in-law apprentice to a scrivener, with whom he lived six years; when, obtaining his freedom by the death of his master, he at twenty years old became the disciple of Reilly; with whom he lived four years, whose niece he married, and of whose style he acquired enough to maintain a solid and lasting reputation even during the lives of Kneller and Dahl, and to remain at the head of the profession when they died. He died suddenly at his house in Queen's square on May 28th, 1745, in the eightieth year of his age. His son was also a man of learning, as appears from the works they published conjointly. The father, in 1719, published two discourses: 1. *An Essay on the Art of*  
Vol. XVIII.

Criticism as it relates to painting; 2. *An Argument in behalf of the Science of a Connoisseur*, bound in 1 vol. 8vo. In 1722 came forth *An Account of some of the statues, bas-reliefs, drawings, and pictures, in Italy, &c.*, with Remarks by Mr. Richardson, senior and junior. The son made the journey; and from his notes, letters, and observations, they both at his return compiled this work. In 1734 they published a very thick 8vo., containing explanatory notes and remarks on Milton's *Paradise Lost*, with the life of the author, and a treatise on the poem. Besides his pictures and commentaries, we have a few etchings by his hand, particularly two or three of Milton, and his own head. The sale of his collection of drawings, in February 1747, lasted eighteen days, and produced about £2060.

**RICHARDSON** (Samuel), a celebrated English novel writer, born in 1688. He was educated as a printer, and, though he is said to have understood no language but his own, yet he acquired great reputation by his three novels, entitled *Pamela*, *Clarissa*, and *Sir Charles Grandison*. A stroke of the palsy carried off Mr. Richardson, after a few days' illness, upon the 4th of July 1761. Besides the works above-mentioned, he is the author of an *Æsop's Fables*, a *Tour through Britain*, 4 vols., and a volume of *Familiar Letters upon business and other subjects*. The most eminent writers, both of our own and of other countries, have paid their tribute to the transcendent talents of Mr. Richardson, whose works have been published in almost every language and country of Europe. Dr. Johnson, in his introduction to the ninety-seventh number of the *Rambler*, which was written by Mr. Richardson, observes that the reader was indebted for that day's entertainment to an author, 'from whom the age has received greater favors; who has enlarged the knowledge of human nature, and taught the passions to move at the command of virtue.' In his life of Rowe, he adds, 'It was in the power of Richardson alone to teach us at once esteem and detestation; to make virtuous resentment overpower all the benevolence which wit, and elegance, and courage, naturally excite; and to lose at last the hero in the villain.'

**RICHELET** (Cæsar Peter), a French writer, born in 1631, at Chemin in Champagne. He was the friend of Patru and Ablancourt. He compiled a dictionary of the French language, of which the best edition is that of Lyons, 3 vols. folio, 1728. He also collected a small dictionary of rhymes. He died in 1698.

**RICHELIEU** (John Armand du Plessis de), cardinal of Richelieu and Fronsac, bishop of Lucon, &c., was born at Paris in 1585. At the age of twenty-two he obtained a dispensation to enjoy the bishopric of Lucon in 1607. Returning to France, he applied himself to preaching; and his reputation procured him the office of almoner to the queen Mary de Medicis. His abilities in the management of affairs advanced him to be secretary of state in 1616: and the king soon gave him the preference to all his other secretaries. On the death of the marquis of Ancre Richelieu retired to Avignon, where he employed himself in composing various theological.

works. The king having recalled him to court, he was made a cardinal in 1622, and two years after first minister of state, and grand master of the navigation. In 1626 the Isle of Rhe was preserved by his care, and Rochelle taken, having stopped up the haven by the famous dike which he ordered to be made there. He accompanied the king to the siege of Casal, and contributed to the raising of it in 1629. He also obliged the Huguenots to the peace of Alets, which proved the ruin of that party: he took Pomerai, and succored Casal, when besieged by Spinola. In the mean time the nobles found fault with his conduct, and endeavoured to persuade the king to discard him. The cardinal, however, instead of being disgraced, from that moment became more powerful than ever, and obtained a greater ascendancy over the king's mind; and he now resolved to humble the excessive pride of the house of Austria. For that purpose he concluded a treaty with Gustavus Adolphus king of Sweden to carry the war into the heart of Germany. He also entered into a league with the duke of Bavaria; secured Lorrain; raised a part of the princes of the empire against the emperor; treated with the Dutch to continue the war against Spain; favored the Catalans and Portuguese till they shook off the Spanish yoke; and, after having carried on the war with success, was about to conclude it by a peace, when he died in Paris on the 4th of December, 1642, aged fifty-eight. He was interred in the Sorbonne, where a magnificent mausoleum was erected to his memory. This great politician made the arts and sciences flourish; formed the botanical garden at Paris, called the king's garden; founded the French Academy; established the royal printing-house; erected the palace afterwards called Le Palais Royal, which he presented to the king; and rebuilt the Sorbonne with a magnificence that appears truly royal. Besides his books of controversy and piety, there go under the name of this minister *A Journal*, in 2 vols. 12mo.; and a *Political Testament*, 12mo.; all treating of politics and state affairs. Cardinal Mazarine pursued Richelieu's plan, and completed many of the schemes which he had begun, but left unfinished.

**RICHLIEU, CHAMBLY**, or Sorel River, a river of Lower Canada, which flows from Lake Champlain in a northerly course, and joins the St. Lawrence.

**RICHLIEU ISLANDS**, a cluster of islands in the St. Lawrence, situated at the south-west entrance of Lake St. Peter, nearly 100 in number. Several of them are cleared, and afford good pasturage for cattle. They lie very low, and abound in wild fowl.

**RICHMOND**, a market town, borough, and parish of Yorkshire, pleasantly situate on the river Swale, which encompasses nearly half the town. It sends two members to the imperial parliament. It has a market on Saturday, two churches, and many handsome houses of stone. It had anciently a castle, built by Alan, earl of Richmond, one of the followers of William the Conqueror. It is forty-four miles north-west of York, sixty south-east of Lancaster, and 234 N. N. W. of London.

**RICHMOND**, a rich, populous, and elegant village of England, in Surrey, seated on the bank of the Thames. It was anciently called Sheen, which in the Saxon signifies resplendent. It had a royal palace, in which Richard II. and Edward I., II., and III. resided, and the latter died in it. In 1497 it was burnt, but Henry VII. rebuilt it in 1501, and gave the place its present name, from his title of earl of Richmond, before he was king. He and his grand-daughter queen Elizabeth died in it. Richmond is famous for its beautiful royal gardens, which in summer are open to the public every Sunday; as well for its elegant and extensive park. It has also a fine observatory. An elegant stone bridge of five arches was here erected over the Thames in 1777. It is nine miles W. S. W. of London.

**RICHMOND**, a county of Virginia, bounded on the north by Westmoreland county, on the north-east by Westmoreland and Northumberland counties, on the south-east by Lancaster county, and on the south-west by the Rappahannock.

**RICHMOND**, a city, port of entry, and the metropolis of Virginia, in Henrico county, on the north side of James River, between fifty and sixty miles, by the course of the river, above City Point, and 150 miles from its mouth, immediately below the falls, at the head of tide water, and opposite Manchester, with which it is connected by two bridges: twenty-five miles north of Petersburg. The city was formerly divided into two sections, the upper or western part, called Shockoe Hill, and the lower part Richmond, separated by Shockoe Creek, a small rivulet; but these distinctions are now going out of use, and the sections are united together. The situation is highly picturesque, beautiful, and healthy; and Richmond is one of the most flourishing, wealthy, and commercial cities in the United States.

It contains about 800 houses built of brick, many of them elegant, and about 600 built of wood; a glass-house, a sugar refinery, an iron foundry, a rolling and slitting mill, a cotton manufactory, eight tobacco warehouses, two insurance offices, three banks, including a branch of the United States bank; a capitol, or state-house, a house for the governor, an armory, a penitentiary, a court house, a jail, an alms house, two market houses, a public library containing about 3000 volumes, a museum, a Lancasterian school, and eight houses of public worship; two for Episcopalians, one for Presbyterians, one for Baptists, two for Methodists, one for Friends, and a Jews' synagogue.

The falls extend nearly six miles, in which distance the river descends eighty feet. A canal with three locks is cut on the north side of the river, terminating at the town in a basin of about two acres. Few cities, situated so far from the sea, possess better commercial advantages than Richmond, being at the head of tide water, on a river navigable for batteaux 220 miles above the city, and having an extensive and fertile back country, abundant in the production of tobacco, wheat, corn, hemp, coal, &c. It has an extensive inland trade, and its foreign commerce is considerable. The shipping owned here, in 1810, amounted to 9943 tons. James River is navi-

gable to Warwick for vessels drawing fifteen or sixteen feet water, and to Rockets, just below Richmond, for vessels drawing ten feet. The exports of the city consist of tobacco, flour, coal, and various articles of produce.

The Virginia armory is an extensive establishment, and there are annually manufactured in it upwards of 4000 stands of arms, 300 rifles, and 1000 cavalry swords and pistols. The penitentiary is under good regulations, and contained, in 1818, 170 prisoners. The new court house is a very spacious and elegant edifice. The capitol is built on a commanding situation on Schockoe Hill, and is a very conspicuous object to the surrounding country. The design was taken from La Maison Quarée at Nismes, and the model was obtained by Mr. Jefferson, while minister there. The edifice, however, falls greatly short of the model. Richmond is at present in a very flourishing and improving state. In 1811, on the 26th of December, the theatre at Richmond took fire during an exhibition, and, in the conflagration, seventy-two persons lost their lives, among whom were George William Smith, esq., governor of the state, and other persons of respectability. An elegant Episcopal church of brick, styled the Monumental Church, has since been erected on the spot, with a monument in front, commemorative of the melancholy event.

**RICHTER** (Otto Frederick Von), an oriental traveller of modern times, was born in Livonia, in 1792. He went to Moscow at the age of sixteen to study modern Greek, and afterwards to Heidelberg, where he applied himself to the Arabic and Persian. He then travelled in Switzerland and Italy, and continued his studies under the celebrated Hammer, at Vienna. He now went with Lindemann, the secretary to the Swedish embassy, to Egypt, where they were well received by Mohamed Ali; and, having travelled up the Nile as far as Ibrim, returned to Alexandria with a rich collection of drawings, &c. At Cairo, in August, 1815, they narrowly escaped destruction during a mutiny of Ali's troops. They then proceeded by sea to Jaffa, and thence to Acre, where they separated, and Richter alone travelled through Palestine, Syria, Asia Minor, and the Isles, and then went to Constantinople to deposit his collections. Having done so, he re-embarked, and, arriving at Smyrna, was there seized with a fever, which terminated his life, August 13th, 1816. M. Ewers, his tutor, published O. F. Von Richter's Wallfahrten im Morgenlande, Berlin, 1822, 8vo, with a folio atlas.

**RICINUS**, or palma Christi, in botany, a genus of the monodelphia order and monœcia class of plants; natural order thirty-eighth, tri-cocceæ: **MALE CAL.** quinquepartite: **COR.** none: the stamina numerous: **FEMALE CAL.** tripartite: **COR.** none: but three bifid styles: **CAPS.** trilocular, and a single **SEED.** There are six species. The most remarkable are these:

1. **R. Americanus** grows as tall as a small tree, and deserves a place in every curious garden. It expands into many branches; the leaves are sometimes two feet in diameter, and the stem as large as a middle-sized broom staff; towards the top of the branch it has a cluster of flowers,

something resembling a bunch of grapes; the flowers are small and staminate, but on the body of the plant grow bunches of rough triangular husks, each containing three speckled seeds, generally somewhat less than horse beans; the shell is brittle, and contains white kernels of a sweet, oily, and nauseous taste. Of the ricinus there are many varieties; all of them fine majestic plants, annual, or at most biennial, in this country; but in their native soil they are said to be perennial both in root and stem. They are propagated by seeds sown on a hot-bed, and require the same treatment as other tender exotics.

2. **R. communis**, or common palma Christi. This tree is of speedy growth, as in one year it arrives at its full height, which seldom exceeds twenty feet. The trunk is subligneous; the pith is large; the leaves broad and palmated; the flower spike is simple, and thickly set with yellow blossoms in the shape of a cone; the capsules are triangular and prickly, containing three smooth gray mottled seeds. When the bunches begin to turn black, they are gathered, dried in the sun, and the seeds picked out. They are afterwards put up for use as wanted, or for exportation. Castor oil is obtained either by expression or by decoction. A large iron pot or boiler is first prepared, and half filled with water. The nuts are then beaten in parcels in deep wooden mortars, and after a quantity is beaten it is thrown into the iron vessel. The fire is then lighted, and the liquor is gently boiled for two hours, and kept constantly stirred. About this time the oil begins to separate, and swims on the top, mixed with a white froth, and is skimmed off till no more rises. The skimmings are heated in a small iron pot, and strained through a cloth. When cold, it is put up in jars or bottles for use. Castor oil, thus made, is clear and well flavored, and if put into proper bottles will keep sweet for years. The expressed castor oil soon turns rancid, because the mucilaginous and acrid parts of the nut are squeezed out with the oil. On this account the preference is given to well prepared oil by decoction. An English gallon of the seeds yields about two pounds of oil. This oil is fit for all the purposes of the painter, or for the apothecary in ointments and plasters. As a medicine, it purges without stimulus, and is so mild as to be given to infants soon after birth, to purge off the meconium. All oils are noxious to insects, but the castor oil kills and expels them. See **PHARMACY** and **MATERIA MEDICA.**

**RICIUS** (Paul), a converted Jew, who flourished in the sixteenth century, and taught philosophy at Pavia with great reputation. The emperor Maximilian appointed him one of his physicians. He is famous for his dispute with Eckius upon the nature of celestial bodies.

**RICK**, *n. s.* See **REEK.** A pile of corn or hay regularly heaped up and sheltered.

Mice and rats do great injuries in the field, houses, barns, and corn ricks. *Mortimer's Husbandry.*

In the North they bind them up in small bundles, and make small ricks of them in the field. *Id.*

An inundation  
O'erflowed a farmer's barn and stable;

2 Q 2



Whole *ricks* of hay and stacks of corn  
Were down the sudden current born. *Swift.*

**RICKETS**, *n. s.* Lat. *rachitis*, of Gr. *ραχις*,  
the spine. A disorder of the spine.

In some years, liver-grown, spleen, and *rickets* are  
put together, by reason of their likeness.

*Graunt's Bills of Mortality.*  
O were my pupil fairly knocked o' th' head,  
I should possess the estate, if he were dead;  
He's so far gone with the *rickets* and the evil,  
That one small dose will send him to the devil.  
*Dryden.*

So when at school we first declaim,  
Old Busby walks us in a theme,  
Whose props support our infant vein,  
And help the *rickets* in the brain;  
But when our souls their force dilate,  
Our thoughts grow up to wit's estate. *Prior.*

The *rickets* is a distemper in children, from an un-  
equal distribution of nourishment, whereby the joints  
grow knotty, and the limbs uneven; its cure is per-  
formed by evacuation and friction. *Quincy.*

In a young animal, when the solids are too lax,  
the case of *rickety* children, the diet should be gently  
astringent. *Arbutnot.*

**RICKETS.** See **MEDICINE.**

**RICKMANSWORTH**, a market town and  
parish of Herts, situate on the river Colne, two  
miles and a half west from Watford, and seven-  
teen north-west from London. The number of  
rivulets in and about the town are employed to  
turn several flour, silk, cotton, and paper mills,  
and many of the females of the town manufac-  
ture straw bonnets for London. The church is  
a spacious building, and there is also a charity  
school and two almshouses. The town is gov-  
erned by two constables and two headboroughs.  
Market-day, Saturday.

**RICOCHET**, in gunnery, is when guns, how-  
itzers, or mortars, are loaded with small charges,  
and elevated from five to twelve degrees, so that,  
when fired over the parapet, the shot or shell  
rolls along the opposite rampart. This is called  
ricochet firing, and the batteries ricochet batte-  
ries. At the battle of Rosbach, in 1757, Frederick  
king of Prussia had several six-inch mortars  
made with trunnions, and mounted on travelling  
carriages, which fired obliquely on the enemy's  
lines, and amongst their horse, loaded with eight  
ounces of powder, and at an elevation of one  
degree fifteen minutes, which did great execution;  
for the shells rolling along the lines, with burn-  
ing fuzes, the soldiers did not dare preserve  
their ranks for fear of their bursting.

The first gun in a ricochet battery should be  
so placed as to sweep the whole length of the  
rampart of the enemy's work, at three or four  
feet from the parapet, and the rest should form  
as small an angle with the parapet as possible.  
For this purpose the guns should be pointed  
about four fathoms from the face of the work  
toward the interior. In the ricochet of ordnance  
in the field, the objects to be fired at being prin-  
cipally infantry and cavalry, the guns should  
seldom be elevated above three degrees, as oth-  
erwise the ball would be apt to bound too high,  
and defeat the object intended. See **FORTIFI-  
CATION.**

**RICOTIA**, in botany, a genus of the siliquosa  
order and tetradynamia class of plants; natural  
order thirty-ninth, siliquosæ. The siliqua is

uniocular, oblong, and compressed, with plain  
valvules.

**RID**, *v. a.* } Sax. *prebban*. In the  
**RID'DANCE**, *n. s.* } preterite ridded or rid; in  
the passive participle rid. To set free; redeem;  
clear; hence drive away; despatch: the noun  
substantive corresponding.

I will bring you out from under their burthens  
and *rid* you out of their bondage. *Erodus vi. 6.*

*Rid* me, and deliver me out of great waters.  
*Psalm cxliv.*

They were not before so willing to be *rid* of their  
learned pastor, as now importunate to obtain him  
again from them, who had given him entertainment.  
*Hooker.*

Deliverance from sudden death, *riddance* from all  
adversity, and the extent of saving mercy towards all  
men. *Id.*

I must *rid* all the seas of pirates. *Shakspeare.*  
Having the best at Barnet field,  
We'll thither straight; for willingness *rids* away. *Id.*

Ah deathsmen! you have *rid* this sweet young  
prince. *Id.*

I have too grieved a heart  
To take a tedious leave: thus losers part.  
—A gentle *riddance*. *Id.*

Upon the word stept forth  
Three of thy crew, to *rid* thee of that care.  
*Ben Jonson.*

I can put on  
Thy terrors, as I put thy mildness on,  
Image of thee in all things, and shall soon,  
Armed with thy might, *rid* heaven of these rebelled.  
*Milton.*

Those blossoms, and those dropping gums,  
That lie bestrown, unsightly and unsmooth,  
Ask *riddance*, if we mean to tread with ease. *Id.*

Did saints for this bring in their plate?  
For when they thought the cause had need on't,  
Happy was he that could be *rid* on't. *Hudibras.*

The god, uneasy till he slept again,  
Resolved at once to *rid* himself of pain. *Dryden.*  
By this the cock had a good *riddance* of his rival.  
*L'Estrange.*

The greater visible good does not always raise  
men's desire, in proportion to the greatness it ap-  
pears to have; though every little trouble *moves* us,  
and sets us on work to get *rid* of it. *Locke.*

The ladies asked, whether we believed that the  
men of any town would, at the same conjuncture,  
have loaden themselves with their wives; or rather,  
whether they would not have been glad of such an  
opportunity to get *rid* of them? *Addison.*

**RID'DLE**, *n. s., v. a., &* } Danish *ride*;  
**RID'DLINGLY**, *adv.* [ *v. n.* } Swed. *rida*; Goth.  
*reida*; Sax. *riæbel*, from *riæban*, to divine. An  
enigma; puzzle; puzzling question: to solve a  
riddle; speak enigmatically: in the manner of  
a riddle.

How did you dare  
To trade and traffic with Macbeth,  
In *riddles* and in charms of death? *Shakspeare.*

Be plain good son, and homely in thy drift;  
*Riddling* confession finds but *riddling* shift. *Id.*

Though like the pestilence and old fashioned love  
*Riddlingly* it catch men, and doth remove  
Never, till it be starved out, yet their state is poor.  
*Lunne.*

The Theban monster that proposed  
Her *riddle*, and him who solved it not devoured;  
That once found out, and solved, for grief and spite  
Cast herself headlong from the Ismenian steep.  
*Milton.*

'Twas a strange *riddle* of a lady;  
Not love, if any loved her: hey day!  
So cowards never use their might,  
But against such as will not fight.

Hudibras.

*Riddle* me this, and guess if you can,  
Who bears a nation in a single man?

Dryden.

It was the maxim of a very wise prince, that 'he who knows not how to dissemble, knows not how to reign:' and I desire that you would receive it as mine, that he who knows not how to *riddle*, knows not how to live.

Fitzosborne's Letters.

RIDE, *v. n. & v. a.* } Sax. *riðan*; Dan. *Riðer*, *n. s.* } *ride*; Swed. *rida*; Goth. *reida*.

To travel on horseback; or be drawn by horses; manage a horse; be borne in a vehicle or vessel; be supported by something subservient; to set on so as to be borne; to manage at will: a rider is the party carried, or who manages a horse.

The horse and his *rider* hath he thrown into the sea.

Exodus.

Am not I thine ass, upon which thou hast *ridden*?

Numbers.

Skill to *ride* seems a science,  
Proper to gentle blood; some others feign  
To manage steeds, as did this vaunter; but in vain.

Spenser.

The sea was grown so rough that the admiral was not able longer to *ride* it out with his galleys; but was enforced to slip his anchors, and run his galleys on ground.

Knolles.

Brutus and Cassius  
Are *rid*, like madmen, through the gates of Rome.

Shakspeare.

Were you but *riding* forth to air yourself,

Such parting were too pretty.

Id.

Infected be the air whereon they *ride*.

Id.

The horses I saw well chosen, *ridden*, and furnished.

Id.

On the western coast

*Rideth* a puissant army.

Id.

They were then in a place to be aided by their ships, which *rode* near in Edinburgh Frith.

Hayward.

They *ride* the air in whirlwind.

Milton.

Waiting him his royal fleet did *ride*,

And willing winds to their low'r sails denied.

Dryden.

Men once walked where ships at anchor *ride*.

Id.

Inspired by love, whose business is to please,  
He *rode*, he fenced, he moved with graceful ease.

Id.

Through storms of smoke and adverse fire he *rides*,  
While ev'ry shot is levelled at his sides.

South.

I would with jockies from Newmarket dine,  
And to rough *riders* give my choicest wine.

Bramstone.

Upon this chaos *rid* the distressed ark, that bore the small remains of mankind.

Burnet.

It is provided by another provincial constitution, that no suffragan bishop shall have more than one *riding* apparitor, and that archdeacons shall not have so much as one *riding* apparitor, but only a foot passenger.

Ayliffe's Parergon.

The strong camel and the gen'rous horse,  
Restrained and awed by man's inferior force,  
Do to the *rider's* will their rage submit,  
And answer to the spur, and own the bit.

Prior.

Humility does not make us servile or insensible nor oblige us to be *ridden* at the pleasure of every coxcomb.

Collier.

Good housewives all the winter's rage despise,  
Defend'd by the *ridinghood's* disguise.

Gay.

The palliolum was like our *ridinghoods*, and served both for a tunic and a coat.

Arbutnot.

Let your master *ride* on before, and do you gallop after him.

Swift's Directions to the Groom.

The nobility could no longer endure to be *ridden* by bakers, cobblers, and brewers.

Swift.

RIDGE, *n. s.* } Sax. *რიგს*; Dan. *rig*; Teut. *Rið'gy*, *adj.* } *rugge*, the back. The top of the back; any protuberance, or mound: to form a ridge: rising in a ridge.

Thou visitest the earth; thou waterest the *ridges* thereof abundantly; thou settlest the furrows thereof.

Psalm lxx. 10.

As when a vulture on Imaus bred,  
Whose snowy *ridge* the roving Tartar bounds,  
Dislodges from a region scarce of prey.

Milton.

Part rise in crystal wall, or *ridge* direct,  
For haste.

Id.

Thou from heaven

Feign'dst at thy birth was given thee in thy hair,  
Where strength can least abide, though all thy hairs,  
Were bristles ranged like those that *ridge* the back  
Of chafed wild boars, or ruffled porcupines.

Id.

He thought it was no time to stay;

But in a trice advanced the knight

Upon the bare *ridge* bent upright.

Hudibras.

About her coasts unruly waters roar,  
And, rising in a *ridge*, insult the shore.

Dryden.

Far in the sea, against the foaming shore,  
There stands a rock, the raging billows roar  
Above his head in storms; but, when 'tis clear,  
Uncurl their *ridgy* backs, and at his feet appear.

Id.

The highest *ridges* of those mountains serve to the maintenance of cattle for the inhabitants of the vallies.

Ray.

Wheat must be sowed above furrow fourteen days before Michaelmas, and laid up in round high warm *ridges*.

Mortimer.

*Ridge* tiles or roof tiles, being in length thirteen inches, and made circular breadthways like an half cylinder, whose diameter is about ten inches or more, and about an inch and half a quarter in thickness, are laid upon the upper part or *ridge* of the roof, and also on the hips.

Moron.

The body is smooth on that end, and on this 'tis set with *ridges* round the point.

Woodward.

Then holding the spectacles up to the court—

Your lordship observes they are made with a straddle

As wide as the *ridge* of the nose is; in short,  
Designed to sit close to it, just like a saddle.

Couper.

RID'ICULE, *n. s. & v. a.* } Fr. *ridicule*;

RID'ICULER, } Lat. *ridiculum*.

RID'ICULOUS, *adj.* } Wit or banter that

RID'ICULOUSLY, *adv.* } provokes laugh-

RID'ICULOUSNESS, *n. s.* } ter: a ridiculer,

one who ridicules: the adjective, adverb, and noun substantive corresponding.

Thus was the building left

*Ridiculous*; and the work confusion named.

Milton.

What sport do Tertullian, Minucius, and Arnobius make with the image consecrated to divine worship! from the meanness of the matter they are made, the casualties of fire, and rottenness they are subject to, on purpose to represent the *ridiculousness* of worshipping such things.

Stillingfleet.

I wish the vein of *-ridiculing* all that is serious and good may have no worse effect upon our state, than knight errantry had on theirs.

Temple.

Epicurus's discourse concerning the original of

the world is so *ridiculously* merry, that the design of his philosophy was pleasure and not instruction.

*South.*

He often took a pleasure to appear ignorant, that he might the better turn to *ridicule* those that valued themselves on their books.

*Addison.*

Sacred to *ridicule* his whole life long,  
And the sad burden of some merry song.

*Pope.*

Those, who aim at *ridicule*,  
Should fix upon some certain rule,  
Which fairly hints they are in jest.

*Swift.*

The *ridiculer* shall make only himself *ridiculous*.  
*Earl of Chesterfield.*

RIDING on horseback. See HORSEMANSHIP.

RIDING, in geography. Yorkshire is divided into three ridings, viz. the east, west, and north ridings. In all indictments in that county, both the town and riding must be expressed.

RIDING, in naval affairs, is the state of a ship's being retained in a particular station, by means of one or more cables with their anchors, which are for this purpose sunk into the bottom of the sea, &c., in order to prevent the vessel from being driven at the mercy of the wind or current. A rope is said to ride, when one of the turns by which it is wound about the capstern or windlass lies over another, so as to interrupt the operation of heaving.

RIDING ATHWART, the position of a ship which lies across the direction of the wind and tide, when the former is so strong as to prevent her from falling into the current of the latter.

RIDING BETWEEN THE WIND AND TIDE, the situation of a vessel at anchor, when the wind and tide act upon her in direct opposition, in such a manner as to destroy the effort of each other upon her hull; so that she is in a manner balanced between their reciprocal force, and rides without the least strain on her cables. When a ship does not labor heavily, or feel a great strain when anchored in an open road or bay, she is said to ride easy. On the contrary, when she pitches violently into the sea, so as to strain her cables, masts, or hull, it is called riding hard, and the vessel is termed a bad roader. A ship is rarely said to ride when she is fastened at both the ends, as in a harbour or river, she being then moored.

RIDLEY (Nicholas), bishop of London, was descended of an ancient family, and born in the beginning of the sixteenth century, at Wilmontswick, in Northumberland. From the grammar school at Newcastle-upon-Tyne he was sent to Pembroke Hall in Cambridge, in 1518, where he was supported by his uncle Dr. Robert Ridley, fellow of Queen's College. In 1522 he took his degree of A. B.; two years after was elected fellow, and in 1525 he commenced M. A. In 1527, having taken orders, he was sent by his uncle for further improvement to the Sorbonne at Paris; thence he went to Louvain, and continued abroad till 1529. On his return to Cambridge he was chosen under treasurer of the university; and, in 1533, was elected senior proctor. He afterwards proceeded B. D., and was chosen chaplain of the university, orator, and magister glomeræ. At this time he was much admired as a preacher and disputant. He lost his uncle in 1536, but was soon after

patronised by Cranmer, archbishop of Canterbury, who made him his domestic chaplain, and presented him to the vicarage of Herne in east Kent. In 1540, having commenced D. D., he was made king's chaplain, and elected master of his new college in Cambridge. Soon after he was collated to a prebend in the church of Canterbury; but was afterwards accused in the bishop's court, by Bishop Gardiner, of preaching against the doctrine of the six articles. The matter being referred to Cranmer, Ridley was acquitted. In 1545 he was made a prebendary of Westminster Abbey; in 1547 he was presented by the fellows of Pembroke Hall to the living of Soham, in the diocese of Norwich; and was consecrated bishop of Rochester. In 1540 he was translated to the see of London; in which year he was one of the commissioners for examining bishop Gardiner, and concurred in his deprivation. In 1552, returning from Cambridge, he unfortunately paid a visit to the princess, afterwards queen Mary; to whom, prompted by his zeal for reformation, he expressed himself with too much freedom; and she was scarcely seated on the throne when Ridley was doomed a victim to her revenge. He was burnt alive with Latimer at Oxford, on the 16th of October, 1555. He wrote, 1. A Treatise concerning Images in Churches. 2. A Brief Declaration of the Lord's Supper. 3. Certain Godly and Comfortable Conferences between Bishop Ridley and Mr. Hugh Latimer, during their Imprisonment. 4. A Comparison between the Comfortable Doctrine of the Gospel, and the Traditions of the Popish Religion, and other works.

RIDLEY (Dr. Gloster), was of the same family with the bishop, and was born at sea in 1702, on board the Gloucester East Indiaman, educated at Winchester school, and thence elected to a fellowship of New College, Oxford, where he proceeded B. C. L. April 29th, 1729. During a vacancy, in 1728, he joined with Mr. Thomas Fletcher (afterwards bishop of Kildare), Mr. (afterwards Dr.) Eyre, Mr. Morrison, and Mr. Jennens, in writing a tragedy called *The Fruitless Redress*, each undertaking an act on a plan previously concerted. When they delivered in their several proportions, few readers would have known that the whole was not the production of a single hand. This tragedy, which was offered to Mr. Wilks, but never acted, is still in MS. with another called *Jugurtha*. Dr. Ridley in his youth was much addicted to theatrical performances. Midhurst, in Sussex, was the place where they were exhibited; and the company of gentlemen actors to which he belonged consisted chiefly of his coadjutors in the above tragedy. For a great part of his life he had no other preferment than the small college living of Westow in Norfolk, and the donative of Poplar in Middlesex, where he resided. To these his college added the donative of Romford in Essex. In 1740 and 1741 he preached *Eight Sermons at Lady Moyer's Lecture*, which were published in 1742, 8vo. In 1763 he published the *Life of Bishop Ridley*, in 4to. by subscription. In 1765 he published his *Review of Philip's Life of Cardinal Pole*; and in 1768,

in reward for his labors in this controversy, and in another which The Confessional produced, he was presented by archbishop Secker to a golden prebend in the cathedral church of Salisbury. He died in 1774, leaving a widow and four daughters.

**RIE**, *n. s.*, or **RYE**, which see. An esculent grain, differing from wheat in having a flatter spike, and the corn larger and more naked.

August shall bear the form of a young man of a fierce aspect, upon his head a garland of wheat and *rie*. *Peucham.*

**RIEGO** (Raphael del), a modern Spanish patriot, was of a noble family, in Asturias. He entered early into the army, and served during the invasion of Spain by Buonaparte. Being taken prisoner, the constitutional general Abisbal on his liberation gave him a staff appointment; and, when his chief betrayed the cause of independence, Riego retired from the service. In 1820 he proclaimed at the head of a battalion the Spanish constitution, and, traversing a large extent of country, shut himself up in a fortress with a small number of troops. Aware however of the danger of delay, he sallied forth from the Isle of Leon with a few hundred followers, made his way through the forces that opposed him, visited several large towns, fought obstinately, lost the greater part of his troops, and retired to the mountains. At last the provinces ranged themselves under his banners, and he was ultimately appointed a deputy to the Cortes of 1822, of which assembly he became president, displaying in this arduous post both a firmness and a conciliatory spirit which did him honor. When Ferdinand refused to maintain the constitution, Riego again appeared in arms to assert the liberty of his country; but was taken prisoner after the surrender of Cadiz to the French, and, being conveyed to Madrid, was executed as a traitor, October 7th, 1823. His widow sought refuge in England, and died at Chelsea, June 19th, 1824.

**RIENZI** (Nicholas Gabrini de), was born at Rome. Though his father was a vintner, and his mother a laundress, they gave their son a liberal education; and to a good natural understanding he joined great assiduity, and made considerable proficiency in ancient literature. He had a strong memory: and retained much of Cicero, Valerius Maximus, Livy, the two Senecas, and Cæsar. He passed whole days among the inscriptions in Rome, and soon was esteemed a great antiquary. He also insinuated himself into the favor of the administration, and was nominated one of the deputies sent to pope Clement VI., who resided at Avignon. The intention of this deputation was to make Clement sensible how prejudicial his absence was to the interest of Rome. While employed in this embassy he took the liberty to tell the pope that the grandees of Rome were avowed robbers, thieves, adulterers, and profligates; who authorised the most horrid crimes. To them he attributed the desolation of Rome; of which he drew so lively a picture that the pope, incensed against the Roman nobility, made Rienzi his apostolic notary, and sent him back loaded with favors. Having returned to

Rome, he began to execute the functions of his office; and by affability, candor, assiduity, and impartiality in the administration of justice, he attained a high degree of popularity. But he still continued his invectives against the vices of the great; till at last he was severely reprimanded and displaced. From this time it was his constant endeavour to inspire the people with a fondness for their ancient liberties; for which purpose he caused to be hung up in the most public places emblematic pictures, expressive of the former splendor and present decline of Rome, and to these he added frequent harangues upon the same subject. Having by these means collected a number of followers, he at last resolved to seize the supreme power. 'The 20th of May, being Whitsunday, he fixed upon to sanctify his enterprise; and asserted that all he acted was by particular inspiration of the Holy Ghost. About nine he came out of the church bare-headed, accompanied by the pope's vicar, surrounded by 100 armed men. A vast crowd followed him with acclamations. The conspirators carried three standards before him, on which were wrought devices, intimating that his design was to reestablish liberty, justice, and peace. In this manner he proceeded directly to the Capitol, where he mounted the rostrum; and expatiated on the miseries to which the Romans were reduced: telling them 'that the happy hour of their deliverance was at length come, and that he was to be their deliverer, regardless of the dangers to which he was exposed for the service of the Holy Father and the people's safety.' After which he ordered the laws of what he called the good establishment to be read; 'assured that the Romans would resolve to observe these laws, he engaged in a short time to reestablish them in their ancient grandeur.' These laws promised plenty and security, and the humiliation of the nobility, who were deemed common oppressors. Such laws could not fail of being agreeable to the people, and enraptured with the pleasing ideas of a liberty to which they had long been strangers, and the hope of gain, they entered most zealously into the fanaticisms of Rienzi. They resumed the authority of the Romans; they declared him sovereign of Rome; and granted him the power of life and death, of rewards and punishments, of enacting and repealing the laws, and treating with foreign powers; in a word, they gave him full and supreme authority in all the territories of the Romans. Rienzi, arrived at the summit of his wishes, pretended to be very unwilling to accept of their offers, except upon two conditions: the first that they should nominate the pope's vicar (the bishop of Orvieto) his copartner; the second that the pope's consent should be granted. The people granted his request, but paid all the honors to him; the bishop appeared a mere shadow, Rienzi was seated in his triumphal chariot. He seized upon the palace, where he continued after he had turned out the senate; and, the same day, he began to dictate his laws from the Capitol.' This election, though not very pleasing to the pope, was ratified by him; nevertheless, Rienzi, as he owed his elevation to the people, chose the title of tribune, as their

magistrate. It was conferred on him and his copartner, with the addition of deliverers of their country. His behaviour in his elevation was at first such as commanded esteem and respect, not only from the Romans, but from the neighbouring states. The troubles of a throne few but princes can properly appreciate, and Rienzi soon found that his exalted station only rendered him a more easy mark for the shafts of envy and hatred, and of distrust. The pope conceived his designs to be contrary to the interests of the holy see; and the nobles conspired against him; they succeeded, and Rienzi was forced to quit an authority he had possessed little more than six months, and to make a precipitate flight. He now went to Prague, to Charles king of the Romans, whom the year before he had summoned to his tribunal, and who, he foresaw, would deliver him up to a pope highly incensed against him. He was accordingly soon after sent to Avignon, and there thrown into prison, where he continued three years. The disturbances in Italy, occasioned by the number of petty tyrants that had established themselves in the ecclesiastical territories, and even in Rome, occasioned his enlargement. Innocent VI., who succeeded Clement, sensible that the Romans still entertained an affection for Rienzi, thought him a proper instrument to assist him in reducing these petty tyrants; and therefore not only gave him his liberty, but appointed him governor and senator of Rome. He met with many obstacles to the assumption of this newly granted authority; all which however he overcame. But giving way to his passions, which were immoderately warm, and attempting to revenge himself on some of his former enemies, he excited a general resentment against him, and he was murdered, October 8th, 1354. 'Such was the end of Nicholas Rienzi, one of the most renowned men of the age; who, after forming a conspiracy apparently the most extravagant, and executing it in the sight of almost the whole world; after causing plenty, justice, and liberty, to flourish among the Romans; after protecting potentates, and terrifying sovereign princes; after re-establishing the ancient majesty and power of the Roman republic, and filling all Europe with his fame during the seven months of his first reign; after having compelled his masters themselves to confirm him in the authority he had usurped against their interests—fell at the end of his second, which lasted not four months, a sacrifice to the nobility, whose ruin he had vowed, and to those vast projects which his death prevented him from putting into execution.'

**RIESENGEBIRGE**, i. e. the Giants' Mountains, a name under which is comprehended all that part of the great Sudetic chain which begins on the borders of Lusatia, and separates Bohemia and Moravia from Silesia, till it joins the Carpathians. This term however is properly confined to that part of the range which lies between the sources of the Neisse and the Bober; a track of no great length, but containing the loftiest mountains of the north or central part of Germany, being almost every where about 3000 feet in height. Of these, the Schneeburge has a height of 5270 English feet; the

great Sturmhaube of 5030, and the lesser Sturmhaube nearly as much. From the top of the first, Breslau (distant seventy miles to the north-east) and Prague (at nearly the same distance to the south-west) are visible. The valleys are picturesque, and produce the finest Alpine plants, but are not well adapted to corn, and the inhabitants are miserably poor.

**RIFEI**, an old town of Italy, in the States of the church, the capital of a delegation of the same name, and situated on the Velino. It is not well built, but is the see of a bishop, and has, besides its cathedral, a number of churches and convents. It has some manufactures of woollens, and in the environs the culture of woad for dyeing is much followed. In 1785 this town was much damaged by an earthquake. Inhabitants 6500. Twenty-five miles S. S. E. of Spoleto, and thirty-seven N. N. E. of Rome.

**RIFE**, *adj.* } Saxon *ryfe*; Belg. *rijf*;  
**RIFELY**, *adv.* } Swed. *ref*. Prevalent; a-  
**RIFEENESS**, *n. s.* } bounding: the adverb and noun-substantive corresponding: used of epidemical distempers.

While those restless desires, in great men *rife*,  
 To visit so low folks did much disdain.  
 This while, though poor, they in themselves did reign. *Sidney.*

Given closely did await  
 Advantage; while his foe did rage most *rife*;  
 Sometimes athwart sometimes he strook him straight,  
 And falsed off his blows. *Spenser.*

The plague was then *rife* in Hungary. *Knolles.*  
 It was *rifely* reported that the Turks were coming  
 in a great fleet. *Id. History.*

Blessings then are plentiful and *rife*,  
 More plentiful than hope. *Hebert.*  
 Space may produce new worlds; whereof so *rife*  
 There went a fame in heaven, that he ere long  
 Intended to create. *Milton's Paradise Lost.*

Before the plague of London, inflammations of the  
 lungs were *rife* and mortal. *Arbutnot on Air.*  
 He ascribes the great *rifeness* of carbuncles in the  
 summer, to the great heats. *Id.*

Secure beneath the storm  
 Which in Ambition's lofty land is *rife*,  
 Where peace and love are cankered by the worm  
 Of pride, each bud of joy industrious to deform.  
*Beattie.*

**RIFLE**, *v. a.* } Fr. *rifler*; *ryfler*; Belg. *rijfe*-  
**RIFLER**, *n. s.* } *len*; Swed. *rifla*. To rob;  
 pillage; plunder; take away.

Stand, Sir, and throw us what you have about  
 you; if not, we'll make you, Sir, and *rife* you.  
*Shakspeare.*

Men, by his suggestion taught,  
 Ransacked the centre, and with impious hands  
 Rifled the bowels of their mother earth.  
 For treasures better hid. *Milton's Paradise Lost.*  
 You have *rifled* my master; who shall maintain  
 me? *L'Estrange.*

A commander in the parliament's rebel army *rifled*  
 and defaced the cathedral at Litchfield. *South.*  
 Mine is thy daughter, priest, and shall remain,  
 And prayers, and tears, and bribes shall plead in  
 vain.

Till time shall *rifle* every youthful grace. *Popc.*

**RIFLE**, in military affairs, a kind of gun, which has the inside of its barrel cut with from three to nine or ten spiral grooves, so as to make it resemble a female screw, varying from a common screw only in this, that its grooves or rifles

are less deflected, and approach more to a right line, it being usual for the grooves with which the best rifled barrels are cut, to take about one whole turn in a length of thirty inches. The number of these grooves differs according to the size of the barrel and fancy of the workman; and their depth and width are not regulated by any invariable rule. There are also different methods of charging pieces of this kind, but the usual one is as follows:—After the powder is put in, a leaden bullet, somewhat larger than the bore of the gun, is taken, and it, having been well greased, is laid on the mouth of the piece, and rammed down with an iron rammer. The softness of the lead giving way to the violence with which the bullet is impelled, that zone of the bullet which is contiguous to the piece, varies its circular form, and acquires the shape of the inside of the barrel, so that it becomes the part of a male screw, exactly fitting the indents of the rifle. And hence it happens that, when the piece is fired, the indented zone of the bullet follows the sweep of the rifles, and thereby, besides its progressive motion, acquires a circular one round the axis of the barrel, which motion will be continued to the bullet after its separation from the piece; by which means a bullet discharged from a rifled barrel is constantly made to whirl round an axis which is coincident with the line of its flight.

In Germany and Switzerland, an improvement is made in the above method, by cutting a piece of very thin leather in a circular shape, larger than the bore of the barrel. This circular piece being greased on one side is laid upon the muzzle with its greasy side downwards, and the bullet, being placed upon it, is then forced down the barrel with it: by which means the leather encloses the lower half of the bullet, and by its interposition between the rifles, prevents the lead from being cut by them. But in those barrels where this method is practised, the rifles are generally shallow, and the bullet ought not to be too large. The rifle-barrels, which have been made in England, where they are not very common, are contrived to be charged at the breech, the piece being, for this purpose, made larger there than in any other part. The powder and bullet are put in through the side of the barrel by an opening, which, when the piece is loaded, is filled up with a screw. By this means, when the piece is fired, the bullet is forced through the rifles, and acquires the same spiral motion as in the former kind of pieces; but these are neither safe nor so certain as the others.

To enable these pieces to be loaded with greater expedition, it has been proposed to have the balls cast with projections to them, by making corresponding hollows round the zone of the bullet-mould; by this means the balls may be fitted so accurately to the rifles as to leave scarcely any windage; while the friction will be less than it is either when the ball is put in at the breech, or forced in at the muzzle. And, to render them in this respect still more complete, the sweep of the rifles should be in each part exactly parallel to each other; for then, after the bullet is once put in motion, it will slide out of the barrel without any shake, and with a much

smaller degree of friction than if the threads of the rifles have not all of them the same degree of incurvation. The foreigners are so exact in this respect that they try their pieces in the following manner:—They first pour melted lead into them, and, letting it cool, they procure a leaden cylinder of perhaps two or three diameters in length, exactly fitted to one part of the inside of the piece; then if this leaden cylinder, being gently pushed by the rammer, will pass from one end of the barrel to the other, without any sensible strain or effort, they pronounce the piece perfect; but if it any where sticks, or moves hard, they esteem it defective.

RIFLEMEN, marksmen armed with rifles. They formed the most formidable enemies during the war in America, being posted along the American ranks, and behind hedges, &c., for the purpose of picking off the British officers; many of whom fell by the rifle in our contest with that country. Most of these were hunters and back woodsmen, who could hit a dollar at eighty paces, and were not therefore likely to miss their aim. In the attack of New Orleans, a band of these men posted behind a breached redoubt rendered it perfectly impregnable. One of these men having claimed the honor of killing a British officer, another asserted that he himself had shot him in the breast. 'I am sure I hit him in the head,' replied the other, and on examination he was found shot through both in the breast and head, though the British troops never approached nearer the rampart than 150 yards. This has been called murderous practice, and some persons have questioned how far it ought to be admitted in civilised warfare; but is not war itself a murderous practice? A citizen of Boston being asked, after the affair at Lexington, 'how he dared to take aim at a British officer as he would at a mad dog?' replied that, 'having made up his mind to fight, he thought he had better take aim to prevent waste of time and ammunition.' Our infantry, on the contrary, never take aim, but, like the heroes of Chalk Farm, generally fire over their opponents' heads. 'The musket in such hands,' observes colonel James, 'is by no means so formidable a weapon as the old English bow. A brigade of rifles has indeed been added to our war establishment, but it is through the line that the system of firing is defective.'

RIFT, *n. s. v. a., & v. n.* Goth. *rifft*. From RIVE. A cleft; breach; opening: to cleave; to burst.

He plucked a bough, out of whose rift there come  
Small drops of gory blood. *Spenser.*

She did confine thee  
Into a cloven pine, within which rift  
Imprisoned, thou didst painfully remain.

*Shakspeare.*

To the dread rattling thunder  
Have I given fire, and rifled Jove's stout oak  
With his own bolt. *Id. Tempest.*

I'd shriek, that even your ears  
Should rift to hear me. *Id. Winter's Tale.*

In St. James's fields is a conduit of brick, unto which joineth a low vault; at the end of that is a round house, with a small slit or rift; and in the conduit a window: if you cry out in the rift, it makes a fearful roaring at the window. *Bacon.*

Some trees are beat for ship-timber, as oaks that

grow in moist grounds ; for that maketh the timber tough, and not apt to *rust* with ordnance.

*Bacon's Natural History.*

Either tropick

'Gan thunder, and both ends of heaven ; the clouds  
From many a horrid *rust* abortive poured  
Fierce rain, with lightning mixt. *Milton.*

At sight of him the people with a shout

*Rifted* the air. *Id. Agonistes.*

Some pick out bullets from the vessels' sides,  
Some drive old oakum through each seam and *rust*.  
*Dryden.*

On *rusted* rocks, the dragon's late abodes,

The green reed trembles. *Pope's Messiah.*

RIG, *v. a.* } From rig or ridge, the back.

RIG'GING, *n. s.* } To dress ; accoutre ; fit with  
tackle : the tackle of a ship : ' cloaths are pro-  
verbially said to be for the back, and victuals  
for the belly.' *Johnson.*

My minde for Egypt stooode ;

When nine faire ships I *rigged* forth for the flood.  
*Chapman.*

He bids them *rig* the fleet. *Denham.*

To plow the deep.

To make fit *rigging*, or to build a ship. *Creech.*

He, like a foolish pilot, hath shipwrecked

My vessel gloriously *rigged*. *Milton's Agonistes.*

His battered *rigging* their whole war receives,

All bare, like some old oak with tempests beat,

He stands, and sees below his scattered leaves.  
*Dryden.*

Jack was *rigged* out in his gold and silver lace,

with a feather in his cap ; and a pretty figure he made  
in the world. *L'Estrange.*

The sinner shall set forth like a ship launched

into the wide sea, not only well built and *rigged* ;

but also carried on with full wind. *South.*

He *rigged* out another small fleet, and the Achæans

engaged him with theirs. *Arbutnot.*

RIGA, the capital of Livonia, European Russia, is situated in a large plain on the Dwina or Duna, nine miles from the sea. It was, in a commercial sense, the second city of Russia, until the rapid increase of Odessa. The port is both spacious and safe ; and the town stands on the right, the suburbs on the left bank of the river. Without being a regular fortress, Riga has considerable strength : the entrance of the river is guarded by the fortress of Dunamunde. The principal public buildings are the town-house, exchange, house of assembly for the states of Livonia, the arsenal, the hospital of St. George, and the Catharinenhof. The church of St. Peter is remarkable for its fine tower. The Baltic being frozen during winter, vessels are laid up in dock here during several months. The Dwina is crossed by a bridge of pontoons, which rise and fall with the tide. Its breadth is forty feet, but its length less than 2600 feet, forming in summer a fashionable promenade. At the beginning of winter the pontoons are removed, and the piles being raised by the frost, are drawn on shore where they remain till spring, the river being, during this interval, passed on the ice. The shipping in the river indicates great activity. The export trade is chiefly managed by English and Scotch houses, whose principal articles of commerce are timber, flax, hemp, and corn. The majority of the inhabitants are Germans and Livonians, the Russians being comparatively few. Canals are the grand desiderata of Russian sea-ports, and a new one is now excavating here

for communication with the interior. The average number of vessels arriving yearly at Riga, is between 700 and 800 ; the computed value of the exports £1,000,000 sterling, of which fully the half are sent to British ports. The manufactures are insignificant, being confined to starch, sugar, and small articles. The imports, if not equal in value to the exports, are more varied, comprising groceries, printed cottons, woollens, silk, and wine, bay-salt and fish. Bay salt, imported chiefly from Spain, is sent up the Dwina. In respect to religion, the majority are Lutherans, or members of the Greek church. There is here a lyceum or academy ; a high school, with a provision for maintaining and educating poor children ; a public library, a cabinet of natural history, and a literary society, all recently formed. Riga has suffered much both by fire and sieges.

The GULF of RIGA is a considerable bay of the Baltic, between Courland, Livonia, and Esthonia. It is also called the Gulf of Livonia.

RIGALTIUS (Nicolas), an ingenious French author, the son of a physician, born in Paris 1577. He was educated among the Jesuits. His first work, *Funus Parasiticum*, printed in 1596, procured him the friendship of Thomas who, when he died in 1617, appointed him a tutor to his children. He was appointed to arrange the royal library along with Isaac Casaubon, whom he succeeded as librarian. He was next made procureur-general of the supreme court of Nancy, counsellor of the parliament of Metz, and intendant of that province. He wrote many learned works, but is chiefly valued for his critical notes upon Cyprian and Tertullian. He died in 1654.

RIGAUD (Hyacinth), an eminent French painter, born at Perpignan, in 1663, and generally called the Vandyck of France. He was director of the Academy of Paintings, and died in 1743.

RIGBY (Richard), esq., an eminent political character, born about 1722. His father was a woollen-draper in London ; and having been appointed factor of the South Sea Company, under the assiento contract with Spain, had accumulated a fortune, and purchased the estate of Mistle Hall in Essex, worth £1100 a-year. Dying, in 1730, he was succeeded by his only son, Richard ; who, on becoming of age, was returned for Sudbury, after a most expensive election, and was soon courted by both parties in parliament. He became attached to the death of Bedford, who, being appointed lord lieutenant of Ireland, took Mr. Rigby with him as his secretary. Under the duke's administration the affairs of Ireland were managed so much to the satisfaction of the king, that he appointed Rigby to the lucrative sinecure place of master of the rolls. The duke, at his death, left him one of his executors, with a large legacy. On the 20th of April, 1763, Mr. Rigby was made a privy counsellor of Great Britain, under the duke of Grafton. On the 6th January, 1768, he was appointed one of the vice-treasurers of Ireland, a sinecure of £3000 a-year, but he soon resigned for the office of paymaster-general of the forces, a place worth £16,000 a-year.

which he held from June 14th, 1768, till March 1732; so that for fourteen years, his annual income was not less than £20,000. The dissolution of lord North's administration put an end also to Mr. Rigby's political existence. He avoided farther interference with all parties, but this did not prevent his being called upon by both to give an account of his administration of the public money. Mr. Rigby compromised matters, and paid £10,000 for the interest of the unsettled balance, a circumstance totally without precedent. He died April 6th, 1788, leaving only one natural daughter.

**RIGGING OF A SHIP**, a general name given to all the ropes employed to support the masts, and to extend or reduce the sails, or arrange them to the disposition of the wind. The former, which are used to sustain the masts, remain usually in a fixed position, and are called standing rigging; such are the shrouds, stays, and back-stays. The latter, whose office is to manage the sails, by communicating with various blocks or pulleys situated in different places of the masts, yards, shrouds, &c., are comprehended in the general term of running rigging; such are the braces, sheets, haliards, clue-lines, brails, &c. See SHIPS.

**RIG GISH**, *adj.* From rig, an old word for a whore. Johnson. Wanton: whorish.

Vilest things

Become themselves in her, that the holy priests  
Bless her, when she is *riggish*.

*Shakespeare.*

<b>RIGHT</b> , <i>adj., adv., interj., n. s.,</i>	} Sax. <i>riht</i> ; Belg. <i>recht</i> ; Teut. <i>recht</i> ; Ital. <i>retto</i> ; Lat. <i>rectus</i> . Fit; proper; just; true; becoming; preferred
<b>RIGHT'EOUS</b> , <i>adj.</i>	
<b>RIGHT'EOUSLY</b> , <i>adv.</i>	
<b>RIGHT'EOUSNESS</b> , <i>n. s.</i>	
<b>RIGHT'FUL</b> , <i>adj.</i>	
<b>RIGHT'FULLY</b> , <i>adv.</i>	
<b>RIGHT'FULNESS</b> , <i>n. s.</i>	
<b>RIGHT'LY</b> , <i>adv.</i>	

(hence the 'right hand'); convenient: as an adverb, direct; according to rule; in a great degree: as a noun-substantive, justice; truth; correctness; just claim; interest; property; immunity: 'to rights' is, to a right or proper position: to right, to do justice to: righteous, just; honest; equitable: the adverb and noun-substantive corresponding: rightful, having the right or a just claim: the adverb and noun-substantive corresponding: rightly, according to right or to justice; exactly: rightness corresponding.

And he took hym by the *right hand* and heuyde hym up.

*Wiclif. Dedis. 3.*

That be far from thee, to slay the *righteous* with the wicked; and that the *righteous* should be as the wicked.

*Genesis.*

The Lord God led me in the *right way*.

*Id. xxiv. 48.*

The people passed over *right* against Jericho.

*Joshua iii. 16.*

Their heart was not *right* with him, neither were they stedfast in his covenant.

*Psalms lxxviii. 37.*

A thousand shall fall at thy side, and ten thousand at thy *right hand*; but it shall not come nigh thee.

*Id. xci. 7.*

Ye shall be driven out *right* forth, and none shall gather up him that wandereth.

*Jeremiah xlix. 5.*

We wish one end; but differ in order and way, that leadeth *rightly* to that end.

*Ascham.*

But still although we fail in perfect *rightfulness*,  
Seek we to tame these superfluities,  
Nor wholly wink though void of purest *sightfulness*.

*Sidney.*

Nor would, for gold or fee  
Be won, their *rightful* causes down to tread.

*Spenser.*

The scripture, ascribing to the persons of men *righteousness*, in regard of their manifold virtues, may not be construed, as though it did thereby clear them from all faults.

*Hooker.*

The proud tyrant would many times say, that whatsoever belonged unto the empire of Rome, was of *right* his, for as much as he was possessed of the imperial scepter, which his great grandfather Mahomet had by law of arms won from Constantine.

*Knolles.*

You are *right*, justice, and you weigh this well;  
Therefore, still bear the balance and the sword.

*Shakespeare.*

The citizens,  
Let them but have their *rights*, are ever forward  
In celebration of this day with shews.

*Id.*

How will this grieve you,  
When you shall come to clearer knowledge, that  
You thus have published me! gentle, my lord,  
You scarce can *right* me thoroughly.

*Id.*

*Right* noble princes,  
I'll acquaint our duteous citizen.

*Id.*

I cannot joy, until I be resolved  
Where our *right* valiant is become.

*Id.*

Some will mourn in ashes, some coal black,  
For the deposing of a *rightful* king.

*Id.*

The rank of osiers, by the murmuring stream,  
Left on your *right-hand* brings you to the place.

*Id.*

Let my jealousies be your dishonour;  
You may be *rightly* just, whatever I shall think.

*Id.*

The Roman citizens were, by the sword, taught to acknowledge the pope their lord, though they knew not by what *right*.

*Raleigh.*

Insects have voluntary motion, and therefore imagination; for ants go *right* forward to their hills, and bees know the way from a flowery heath to their hives.

*Bacon.*

Persons of noble blood are less envied in their rising; for it seemeth but *right* done to their birth.

*Id.*

Sounds move strongest in a *right* line, which nevertheless is not caused by the *rightness* of the line but by the shortness of the distance.

*Id. Natural History.*

When I had climbed a height  
Rough and *right* hardly accessible; I might  
Behold from Circe's house, that in a grove  
Set thicke with trees stood, a bright vapour move.

*Chapman.*

The senate will smart deep  
For your upbraidings: I should be *right* sorry  
To have the means so to be venged on you,  
As I shall shortly on them.

*Ben Jonson.*

I mention the *right* honourable Thomas Howard,  
lord high marshal.

*Peacham on Drawing.*

His faith perhaps in some nice tenets might  
Be wrong; his life I'm sure was in the *right*.

*Cromley.*

If the injured person be not *righted* every one of them is wholly guilty of the injustice, and bound to restitution.

*Taylor.*

Their only thoughts and hope was to defend their own *rights* and liberties, due to them by the law.

*Clarendon.*

On his *right*

The radiant image of his glory sat,  
His only Son.

*Milton*



This way, right down to Paradise descend. *Id.*  
 One rising, eminent  
 In wise deport, spake much of right and wrong,  
 Of justice, of religion, truth, and peace,  
 And judgment from above. *Id. Paradise Lost.*

Subdue by force, all who refuse  
 Right reason for their law; and for their king  
 Messiah, who by right of merit reigns. *Milton.*  
 Each of his reign allotted, *rightlier* called  
 Powers of fire, air, water, and earth beneath. *Id.*  
 Descend from heaven, Urania! by that name  
 If *rightly* thou art called. *Id. Paradise Lost.*

Right many a widow his keen blade,  
 And many fatherless hath made. *Hudibras.*  
 It is not with certainty to be received concerning  
 the right and left hand, that men naturally make  
 use of the right, and that the use of the other is a  
 digression. *Browne.*

You, with strict discipline instructed right,  
 Have learned to use your arms before you fight.  
*Roscommon.*

I could not expedient see,  
 On this side death, to right our family. *Waller.*  
 God hath a sovereign right over us, as we are his  
 creatures, and by virtue of this right, he might,  
 without injustice, have imposed difficult tasks: but  
 in making laws, he hath not made use of this right.  
*Tillotson.*

Some seeking unto courts, and judicial endeavours  
 to right ourselves, are still innocent. *Kettleworth.*  
 Our calendar wants to be reformed, and the equi-  
 nox *rightly* computed; and, being once reformed and  
 set right, it may be kept so, by omitting the additional  
 day at the end of every hundred and thirty-four  
 years. *Holder on Time.*

The custom of employing these great persons in  
 all great offices passes for a right. *Temple.*  
 The left foot naked, when they march to fight,  
 But in a bull's raw hide they sheathe the right.  
*Dryden.*

Take heed you steer your vessel right, my son,  
 This calm of heaven, this mermaid's melody,  
 Into an unseen whirlpool draws you fast,  
 And in a moment sinks you. *Id.*

The pris'ner freed himself by nature's laws,  
 Born free, he sought his right. *Id.*

Make my father known,  
 To right my honour, and redeem your own. *Id.*

Kill my rival too, for he no less  
 Deserves; and I thy *righteous* doom will bless. *Id.*

Here wretched Phlegias warns the world with  
 cries,

Could warning make the world more just or wise;  
 Learn *righteousness*, and dread the avenging deities.  
*Id.*

My right to it appears,  
 By long possession of eight hundred years. *Id.*

Descriptions, figures, and fables, must be in all  
 heroic poems; every poet hath as much right to  
 them, as every man hath to air. *Id.*

Henry, who claimed by succession, was sensible  
 that his title was not found, but was *rightfully* in  
 Mortimer, who had married the heir of York.

*Id. Preface to Fables.*

Should I grant, thou didst not *rightly* see;  
 Then thou wert first deceived. *Dryden.*  
 Might and right are inseparable in the opinion of  
 the world. *L'Esrange.*

To understand political power right, and derive it  
 from its original, we must consider what state all  
 men are naturally in, and that is a state of perfect  
 freedom to order their actions, and dispose of their  
 possessions and persons. *Locke.*

There being no law of nature, nor positive law of  
 God, that determines which is the right heir in all

cases, the right of succession could not have been  
 certainly determined. *Id.*

The idea of a right lined triangle necessarily car-  
 ries with it an equality of its angles to two right ones.  
*Id.*

A man can never have so certain a knowledge,  
 that a proposition which contradicts the clear princi-  
 ples of his own knowledge, was divinely revealed,  
 or that he understands the words *rightly*, wherein it  
 is delivered; as he has, that the contrary is true.  
*Id.*

Good men often suffer, and that even for the sake  
 of *righteousness*. *Nelson.*

It is not necessary for a man to be assured of the  
*righteousness* of his conscience, by such an infallible  
 certainty of persuasion as amounts to the clearness of  
 a demonstration; but it is sufficient if he knows it  
 upon grounds of such a probability as shall exclude  
 all rational grounds of doubting. *South.*

Agrippa is severally ranged in sets of medals  
 among the emperors; as some among the empresses  
 have no other right. *Addison.*

Seldom your opinions err;  
 Your eyes are always in the right. *Prior.*

Gather all the smiling hours;  
 Such as with friendly care have guarded

Patriots and kings in *rightful* wars. *Id.*

We invade the rights of our neighbours, not upon  
 account of covetousness, but of dominion, that we  
 may create dependencies. *Collier on Pride.*

These strata failing, the whole tract sinks down to  
 rights in the abyss, and is swallowed up by it.  
*Woodward.*

Like brute beasts, we travel with the herd, and  
 are never so solicitous for the *rightness* of the way,  
 as for the number or figure of our company.  
*Rogers's Sermon.*

A time there will be, when all these unequal dis-  
 tributions of good and evil shall be set right, and the  
 wisdom of all his transactions made as clear as the  
 noon-day. *Aterbury.*

Right, cries his lordship, for a rogue in need  
 To have a taste is insolence indeed;

In me 'tis noble, suits by birth and state. *Pope.*

Is this a bridal or a friendly feast?  
 Of whom their deeds I *rightlier* may divine,

Unseemly flown with insolence or wine. *Id.*

If my present and past experience do exactly coin-  
 cide, I shall then be disposed to think them both  
 right. *Beattie.*

RIGHTS, BILL OF, in law, is a declaration  
 delivered by the lords and commons to the  
 prince and princess of Orange, 13th of February  
 1688; and afterwards enacted in parliament,  
 when they became king and queen. It sets  
 forth that king James did, by the advice of  
 divers evil counsellors, endeavour to subvert the  
 laws and liberties of this kingdom, by exercising  
 a power of dispensing with and suspending of  
 laws; by levying money for the use of the  
 crown, by pretence of prerogative, without the  
 consent of parliament; by prosecuting those who  
 petitioned the king, and discouraging petitions;  
 by raising and keeping a standing army in time  
 of peace; by violating the freedom of election of  
 members to serve in parliament; by violent pro-  
 secutions in the court of king's bench, and  
 causing partial and corrupt jurors to be returned  
 on trials, excessive bail to be taken, excessive  
 fines to be imposed, and cruel punishments to be  
 inflicted; all of which were declared to be  
 illegal. And the declaration concludes in these  
 remarkable words; and they do claim, demand,

and insist upon, 'all and singular the premises, as their undoubted rights and liberties.' And the act of parliament itself (1 W. & M. stat. 2 cap. 2), recognizes 'all and singular the rights and liberties asserted and claimed in the said declaration to be the true, ancient, indubiable rights of the people of this kingdom.'

**RIG'ID**, *adj.* } Fr. *rigide*; Lat. *rigidus*.  
**RIG'IDITY**, *n. s.* } Stiff; inflexible; unpliant;  
**RIG'IDLY**, *adv.* } severe; cruel; the noun-  
**RIG'IDNESS**, *n. s.* } substantives and adverb  
 corresponding.

This severe observation of nature, by the one in her comest, and by the other in her absolutest forms, must needs produce in both a kind of *rigidity*, and consequently more naturalness than gratefulness. *Wotton's Architecture.*

His severe judgment giving law,  
 His modest fancy kept in awe;  
 As *rigid* husbands jealous are,  
 When they believe their wives too fair. *Denham.*

Queen of this universe! do not believe  
 Those *rigid* threats of death; ye shall not die.  
*Milton.*

A body that is hollow may be demonstrated to be more *rigid* and inflexible than a solid one of the same substance and weight. *Ray on the Creation.*

Cressy plains  
 And Agincourt, deep tinged with blood, confess  
 What the Silures vigour unwithstood  
 Could do in *rigid* fight. *Philips.*

*Rigidity* is said of the solids of the body, when, being stiff or impliable, they cannot readily perform their respective offices; but a fibre is said to be *rigid* when its parts so strongly cohere together, as not to yield to that action of the fluids, which ought to overcome their resistance in order to the preservation of health. *Arbuthnot.*

**RIG'LET**, *n. s.* Fr. *regulet*, of Lat. *regula*. A flat thin square piece of wood, used by printers and others.

The pieces that are intended to make the frames for pictures, before they are moulded, are called *riglets*. *Moxon.*

**RIG'OL**, *n. s.* [perhaps a corruption of **RING'LE**]. A circle. Used in Shakspeare for a diadem.

This sleep is sound; this is a sleep,  
 That, from his golden *rigol*, hath solided  
 So many English kings. *Shakspeare. Henry IV.*

**RIGOLL**, or **REGAL**, a kind of musical instrument, consisting of several sticks bound together, only separated by beads, and struck with a ball at the end of a stick. Such is the account which Grassineau gives of this instrument. Skinner, upon the authority of an old English dictionary, represents it as a clavichord; possibly founding his opinion on the nature of the office of the tuner of the regals. Sir Henry Spelman derives the word *rigoll* from the Italian *rigabello*, a musical instrument, anciently used in churches instead of the organ. Walther, in his description of the *regal*, makes it to be a reed-work in an organ, with metal and also wooden pipes and bellows adapted to it. He adds that the name of it is supposed to be owing to its having been presented by the inventor to some king. From an account of the

*regal* used in Germany, and other parts of Europe, it appears to consist of pipes and keys on one side, and the bellows and wind chest on the other. Lord Verulam distinguishes between the *regal* and the organ, in a manner which shows them to be instruments of the same class. Upon the whole, there is reason to conclude that the *regal* or *rigoll* was a pneumatic and not a stringed instrument. Marsennus relates that the Flemings invented an instrument, *les regales de bois*, consisting of seventeen cylindrical pieces of wood, decreasing gradually in length, so as to produce a succession of tones and semitones in the diatonic series, which had keys, and was played on as a spinet; the hint of which, he says, was taken from an instrument in use among the Turks, consisting of twelve wooden cylinders, of different lengths, strung together, which being suspended and struck with a stick, having a ball at the end, produced music.—Hawkins's Hist. Mus. vol. ii. p. 449.

**RIG'OR**, *n. s.* } Lat. *rigor*. Cold; stiff-  
**RIG'OROUS**, *adj.* } ness; straitness; grimly;  
**RIG'OROUSLY**, *adv.* } applied to the cold fit of  
 some diseases; rage: the adjective and adverb  
 corresponding.

He at his foe with furious *rigour* smites,  
 That strongest oak might seem to overthrow;  
 The stroke upon his shield so heavy lights  
 That to the ground it doubleth him full low.

It may not seem hard, if in cases of necessity certain profitable ordinances sometimes be released, rather than all men always strictly bound to the general *rigour* thereof. *Hooker.*

He shall be thrown down the Tarpeian rock  
 With *rigorous* hands; he hath resisted law,  
 And therefore law shall scorn him further trial  
 Than the severity of public power. *Shakspeare.*

Driven by the necessities of the times and the temper of the people, more than led by his own disposition to any height and *rigour* of actions. *King Charles.*

Nature has got the victory over passion, all his *rigour* is turned to grief and pity. *Denham's Sophy.*

Heat and cold are not, according to philosophical *rigour*, the efficient; but are names expressing our passions. *Glanville.*

He resumed his *rigours*, esteeming his calamity such a one as should not be outlived, but that it became men to be martyrs to. *Fell.*

The rest his look  
 Bound with Gorgonian *rigour*, not to move. *Milton.*  
 Lest they faint

At the sad sentence *rigorously* urged,  
 For I behold them softened, and with tears,  
 Bewailing their excess, all terror hide. *Id.*

The stones the *rigour* of their kind expel,  
 And supple into softness as they fell. *Dryden.*  
 Does not looseness of life, and want of a due sobriety in some, drive others into *rigours* that are unnecessary? *Sprat.*

The base degenerate age requires  
 Severity and justice in its *rigour*:  
 This awes an impious bold offending world. *Addison.*

Are these terms hard and *rigorous*, beyond our capacities to perform? *Rogers's Sermons.*

*Rigors*, chillness, and a fever. attend every such new supputation. *Blackmore.*

*Rigour* makes it difficult for sliding virtue to recover. *Clarissa.*

**RILL**, *n. s.* & *v. a.* } Lat. *rivulus*. A small  
**RILLER**, *n. s.* } brook; a streamlet: to  
 run in small streams.

The' industrious muse thus labours to relate,  
 Those *rilllets* that attend proud Tamer and her state.

*Drayton.*

A creeke of Ose, between two hills, delivering a  
 little fresh *rillet* into the sea. *Carew.*

May thy brimmed waves from this  
 Their full tribute never miss,  
 From a thousand petty *rills*,  
 That tumble down the snowy hills. *Milton.*

Io! Apollo, mighty king, let envy,  
 Ill-judging and verbose, from Lethe's lake,  
 Draw tuns immeasurable; while thy favour  
 Administers to my ambitious thirst  
 The wholesome draught from Aganippe's spring  
 Genuine, and with soft murmurs gently *rilling*  
 Adown the mountains where thy daughters haunt.

*Prior.*

On every thorn delightful wisdom grows,  
 In every *rill* a sweet instruction flows;  
 But some, untaught, o'erhear the whispering *rill*,  
 In spite of sacred leisure blockheads still. *Young.*

There, as meek Evening wakes her temperate  
 breeze,  
 And moon-beams glimmer through the trembling  
 trees,

The *rills* that gurgle round shall sooth her ear,  
 The weeping rocks shall number tear for tear.

*Darwin.*

**RIM**, *n. s.* Sax. *rima*; Teut. *rem*. A border;  
 margin; boundary.

We may not affirm that ruptures are confinable  
 unto one side, as the peritoneum or *rim* of the belly  
 may be broke; or its perforations relaxed in either.

*Broune's Vulgar Errors.*

The drum-maker uses it for *rimbs*. *Mortimer.*

It keeps off the same thickness near its centre;  
 while its figure is capable of variation towards the  
*rim*. *Grew.*

**RIME**, *n. s.* Sax. *þrim*. Hoar frost: also  
 of Goth. *rimma*, a hole; chink.

Breathing upon a glass gives a dew; and in *rime*  
 frosts you shall find drops of dew upon the inside of  
 glass windows. *Bacon.*

The air is now cold, hot, dry, or moist; and then  
 thin, thick, foggy, *rimy*, or poisonous. *Harvey.*

Though birds have no epiglottis, yet can they contract  
 the *rime* or clink of their larinx, so as to prevent  
 the admission of wet or dry indigested.

*Broune's Vulgar Errors.*

In a hoar frost, a *rime* is a multitude of quadrangular  
 prisma piled without any order one over another.  
*Grew.*

**RIMINALDI** (Orazio), an eminent historical  
 painter, born at Pisa in 1598. His chief paintings  
 are Samson destroying the Philistines, the  
 Brazen Serpent, and the Assumption of the  
 Virgin. He died in 1638.

**RIMINI**, the ancient Ariminum, a large town  
 of the Ecclesiastical States, Italy, situated on  
 the Marecchia, near its embouchure. It had  
 formerly a good harbour; but the sea has now  
 retired to the distance of a mile and a half; and  
 the town is surrounded by a plain, opening on  
 the one side to the Adriatic, and bounded on the  
 other by a range of hills, which terminate in the  
 great chain of the Appennines. It communicates  
 with the sea by means of a canal which is  
 almost choked at the mouth. Its streets are straight,  
 and contain several churches and family mansions

of beautiful marble. In the principal square  
 is a marble fountain, with a statue of pope Paul  
 V., and in the middle of the market place a  
 pedestal, from which tradition says that Cæsar  
 harangued his army.

The cathedral and several churches of Rimini  
 are ornamented with marble, procured from the  
 ruins of the old harbour. That of St. Francis, a  
 fine edifice of the fifteenth century, has a profu-  
 sion of sculptures, statues, and bas reliefs. Ri-  
 mini contains several valuable remains of Roman  
 architecture. At the entrance of the town, on  
 the side of Pesaro, stands a triumphal arch of  
 Augustus, adorned with Corinthian columns,  
 from which a broad street extends to an elegant  
 bridge over the Marecchia, begun by Augustus,  
 and completed by Tiberius. It is 220 feet in  
 length, and consists of five arches of white stone  
 or marble, found in the neighbourhood. Its  
 execution is remarkably wild and elegant. Ri-  
 mini was called Ariminum from the river Arimi-  
 nus, which washed its walls, and formed at one  
 time a small independent republic. At present  
 its chief pursuit is supplying the interior with  
 fish. It is the see of a bishop. Twenty-eight  
 miles S. S. E. of Ravenna, fifty north-west of  
 Ancona, and 150 north of Rome.

**RIMPLE**, or **RUMPLE**, *v. a.* To pucker;  
 contract into folds. See **CRUMPLE** and **RU-  
 MPLE**.

The skin was tender, also *rimpled* and blistered.

*Wiseman.*

**RIND**, *n. s.* & *v. n.* Sax. *rimb*; Belg. and  
 Teut. *rinde*. Bark; husk: to bark; peel.

Therewith a piteous yelling voice was heard,  
 Crying, O spare with guilty hands to tear  
 My tender sides in this rough *rind* embar'd.

*Spenser.*

Within the infant *rind* of this small flower  
 Poison hath residence, and medicine power.

*Shakespeare.*

Thou can'st not touch the freedom of this mind  
 With all thy charms, although this corporal *rind*  
 Thou hast immanac'd. *Milton.*

These plants are neither red nor polished, when  
 drawn out of the water, till their *rind* have been  
 taken off. *Boyle.*

This monument thy maiden beauty's due,  
 High on a plane-tree shall be hung to view;  
 On the smooth *rind* the passenger shall see  
 Thy name engraved, and worship Helen's tree.

*Duden.*

**RING**, *v. a.*, *v. n.*, & *n. s.* } Sax. *pringan*;  
**RINGER**, *n. s.* } Isl. *kringu*; Belg.

**ringen**. To strike a bell or other sonorous body,  
 so as to produce sound; to sound in this way;  
 to practise ringing with bells; resound; tinkle;  
 be filled with a report: a number of tuned  
 bells; the sound of them; any loud sound.

*Ring* the alarum bell. *Shakespeare. Macbeth.*

Ere to black Hecat's summons

The shard-born beetle, with his drowsy hums,  
 Hath rung night's yawning peal, there shall be done  
 A deed of dreadful note. *Shakespeare.*

Hercules, missing his page, called him by his  
 name aloud, that all the shore rang of it. *Bacon.*

Stop the holes of a hawk's bell, it will make no  
*ring*, but a flat noise or rattle. *Id.*

The king, full of confidence, as he had been vic-  
 torious in battle, and had prevailed with his parlia-  
 ment, and had the ring of acclamations fresh in his

ears, thought the rest of his reign should be but play.  
*Id. Henry VII.*  
 The heavens and all the constellations rung.  
*Milton.*

Ring out ye crystal spheres,  
 And let your silver chime  
 Move in melodious time;  
 And let the base of heaven's deep organ blow. *Id.*  
 Signs for communication may be contrived in pleasure; four bells admit twenty-four changes in ringing; each change may, by agreement, have a certain signification. *Holder.*

At Latagus a weighty stone he flung;  
 His face was flatted, and his helmet rung. *Dryden.*  
 My ears will ring with noise; I'm vexed to death:  
 Tongue-kill'd, and have not yet recover'd breath. *Id.*

The particular ringing sound in gold, distinct from the sound of other bodies, has no particular name. *Locke.*

Easy it might be to ring other changes upon the same bells. *Norris's Miscellanies.*  
 That profane, atheistical, epicurean rabble, whom the whole nation so rings of, are not indeed what they vote themselves, the wisest men in the world. *South.*

A squirrel spends his little rage,  
 In jumping round a rolling cage;  
 The cage is either side turned up,  
 Striking a ring of bells a-top. *Prior.*

With sweeter notes each rising temple rung,  
 A Raphael painted! and a Vida sung!  
 Immortal Vida! *Pope.*

RING, *n. s. & v. a.* Sax. *prang*; Dan. *Swed.*  
 RING-BONE, *n. s.* Teut. and Belg. *ring.* A  
 RING-DOVE, circle; circular line, particularly of metal; circular course; circle of persons: to encircle; fit with  
 RINGER, rings: the ringbone is defined in the extract: ring-  
 RING-LEADER, }  
 RING-LET, }  
 RING-STREAKED, }  
 RING-TAIL, *n. s.* }  
 RING-WORM, }  
 so called from the ring of feathers round its neck: ringleader, the head of a ring or knot of riotous persons: ringlet, a small ring: ring-streaked, streaked circularly: ring-tail, a kind of kite: ring-worm, a circular tetter.

He removed the he goats that were ringstreaked and spotted, and all the she goats that were speckled. *Genesis xxx. 35.*

In this habit  
 Met I my father with his bleeding rings,  
 Their precious gems now lost. *Shakespeare.*

A quarrel  
 —About a hoop of gold, a paltry ring. *Id.*

Talbot,  
 Who, ringed about with bold adversity,  
 Cries out for noble York and Somerset. *Id.*

Death, death; oh amiable lovely death!  
 Thou odoriferous stench, sound rottenness,  
 Arise

And I will kiss thy detestable bones,  
 And put my eye-balls in thy vaulted brows,  
 And ring these fingers with thy household worms. *Id.*

You demy puppets, that  
 By moon-shine do the green ringlets make,  
 Whereof the ewe not bites. *Id. Tempest.*

He caused to be executed some of the ringleaders of the Cornish men, in sacrifice to the citizens. *Bacon's Henry VII.*

Her golden tresses in wanton ringlets waved,  
 As the vine curls her tendrils. *Milton.*

The Italians, perceiving themselves almost environed, cast themselves into a ring, and retired back into the city. *Hayward.*

The rings of iron, that on the doors were hung,  
 Sent out a jarring sound, and harshly rung. *Dryden.*

Round my labour a new ring they made,  
 And footed it about the sacred shade. *Id.*  
 Pigeons are of several sorts, wild and tame; as wood-pigeons, doves, and ringduces. *Mortimer.*

Chaste Diana,  
 Goddess presiding o'er the rapid race,  
 Place me, O place me, in the dusty ring,  
 Where youthful charioteers contend for glory! *Smith.*

I have seen old Roman rings so very thick about, and with such large stones in them, that 'tis no wonder a fop should reckon them a little cumbersome in the summer. *Addison.*

The nobility escaped; the poor people, who had been deluded by these ringleaders, were executed. *Id.*

Bubbles of water, before they began to exhibit their colours to the naked eye, have appeared through a prism girded about with many parallel and horizontal rings. *Newton.*

It began with a serpigo, making many round spots, such as are generally called ringworms. *Wiseman's Surgery.*

Silver the lintels, deep projecting o'er,  
 And gold the ringlets that command the door. *Pope.*

Some eagle got the ring of my box in his beak, with an intent to let it fall and devour it. *Swift.*

Ring-bone is a hard callous substance growing in the hollow circle of the little pastern of a horse, just above the coronet: it sometimes goes quite round like a ring, and thence it is called the ring-bone. *Farrier's Dictionary.*

'Twas not her golden ringlets bright  
 Her lips like roses wet w' dew,  
 Her heaving bosom lily-white;—  
 It was her een sae bonnie blue. *Burn.*

RING. The episcopal ring (which makes a part of the pontifical apparatus, and is esteemed a pledge of the spiritual marriage between the bishop and his church) is of very ancient standing. The fourth council of Toledo, held in 633, appoints that a bishop condemned by one council, and found afterwards innocent by a second, shall be restored by giving him the ring, staff, &c. From bishops, the custom of the ring has passed to cardinals, who have sometimes paid enormous sums pro jure annuli cardinalitii.

RING, in astronomy and navigation, an instrument used for taking the sun's altitude, &c. It is usually of brass, about nine inches diameter, suspended by a little swivel: at the distance of 45° from the point of which is a perforation, which is the centre of a quadrant of 90° divided in the inner concave surface. To use it, let it be held up by the swivel, and turned round to the sun, till his rays, falling through the hole, mark a spot among the degrees, which shows the altitude required. This instrument is preferred to the astrolabe, because the divisions are here larger than on that instrument.

RING-OUSEL, in ornithology, a species of turdus.

RING-TAIL. See FALCO.

RINGWOOD, a large market town and parish

of Hampshire, on the Avon, with a market on Wednesday, and a considerable manufacture of knit worsted hose. Many of the houses and the church are well built. This town has long been celebrated for the excellence of its ale, of which it exports considerable quantities; it also trades in leather, druggets, and some narrow cloths. Near it the duke of Monmouth was taken after his defeat at Sedgmoor, in 1685. It is fourteen miles N. N. E. of Pool, thirty south-west of Winchester, and ninety-one west by south of London.

RINSE, *v. a.* } From Teut. *rein*, pure, clear.

RINS'ER, *n. s.* } To wash; cleanse: a washer.

Whomsoever he toucheth, and hath not rinsed his hands in water, he shall be unclean.

*Leviticus xv. 11.*

This must move us humbly to sue unto God, and earnestly to intreat him, to wash us thoroughly from our wickedness, and cleanse us from our sins: yea to purge and *rinse* the fountain thereof, our unclean and polluted hearts.

*Perkins.*

This last costly treaty

Swallowed so much treasure, and like a glass

Did break i' the rinsing. *Shakspeare. Henry VIII.*

They cannot boil, nor wash, nor *rinse*, they say, }  
With water sometimes ink, and sometimes whey, }  
According as you meet with mud or clay. *King.* }

RIO DEL REY, a river of South Western Africa, falling into the gulf of Benin. Its mouth is broad; but a great part is shallow, there being only an open channel in the middle navigable by large vessels. Its early course is unknown; but it is reported to come from the north, and to receive some considerable streams. The country on each side is marshy but fertile. The Calbongos, as they are called, of this neighbourhood, are a numerous and barbarous race, almost naked, and smearing themselves with a red paint. They are said to be much corrupted by the slave trade. The chief trade in the river carried on here is by the Portuguese and Dutch, who procure slaves and a small quantity of ivory. The mouth is in long. 8° 5' E., lat. 4° 30' N.

RIO GRANDE, a province of Brasil, is bounded by the capitania of St. Paul's on the north, Matto Grosso on the west, and the Rio de la Plata on the south. It may be called the granary of Brasil, and wheat is shipped here to all the ports on the coast. Farming, however, is carried on in a slovenly manner; the grain is always rough and foul, and is packed in raw hides, which are sewed up like sacks, so that it frequently swells and heats on the passage. This province is extremely populous; in a circuit of twenty leagues the inhabitants are estimated at 100,000. Their principal occupations are, the breeding of cattle, drying and preparing of hides, and the making of charque, or what is called in the river Plata jug-beef, or beef dried and salted in a particular way. It is in taste somewhat similar to hung-beef, and constitutes the general food of the sailors and lower orders, forming part of almost every cargo sent out from this province. The quantity of hides exported hence is almost incredible; they furnish many vessels with entire cargoes, which are carried to the northern ports, and thence embarked for Europe. The annual average may be estimated at not less than 300,000. Tallow is

another considerable article, which in general is shipped in the crude state. The greater part is consumed in other parts of Brasil. It is packed in waste raw hide packages. Horns and horse-hair form an inferior branch of commerce. The above are the staple productions of Rio Grande, which give employment to perhaps 100 sail of coasters. During the old system, so lately as within these few years, a most lucrative trade was here carried on with the Spaniards, who came in numbers, and most eagerly bought up the tobacco, and such of the English manufactures as could be transported on horseback at great prices. Thus Rio Grande and its vicinity became very enviable situations, where considerable fortunes were made.

The neighbourhood of the capital is unpleasant, being surrounded with sand and sand-hills of no inconsiderable size, formed by the wind, and frequently brought by it into every part of the houses. The cattle bred in this capitania are very numerous. The large river Uruguay rises here, and empties itself into the river Plata, a little above Buenos Ayres. There are numerous others of less consequence, and much wood. Some attempts were lately made, by miners sent from Villa Rica, to work gold washings, and in the neighbourhood of the capital they have coal, a specimen of which Mr. Mawe mentions. In various parts jaguars and beasts of prey are very common; among the granivorous animals are capivaras of great size, deer, and armadillos, which are excellent eating. Of birds the ostriches of the dark colored species go about in immense flocks. There are also eagles, hawks, and other birds of prey. The inhabitants are, generally speaking, athletic, and robust, and excellent horsemen. It is singular to Europeans that in this fine climate, where the thermometer is frequently below 40° Fahrenheit, and where are bred as fine cows as any in the world, and every convenience is at hand for dairies, neither butter nor cheese is made, except on particular occasions. In some places the grapes are good, and probably wine will soon be made from them, as the restraint laid by the mother country is now removed. The port through which the commerce of Rio Grande is carried on is situated about 32° south; it is dangerous to enter, first from its being shoal water, and next, from a violent sea always running, and the shifting of the sands. There is notwithstanding a great trade carried on from this place to all the ports of Brasil. The principal town is defended by many forts, some of which are upon islets. Since it was taken from the Spaniards, by general Coimbra, the Portuguese have much strengthened it, and now there is a very considerable force of cavalry, horse artillery, and foot soldiers.

RIOM, a large and central town of France, in the department of the Puy de Dome, delightfully situated on a declivity, which commands a view of the Limagne d'Auvergne. It has a cour royale, is regularly built, being traversed diametrically by two principal streets, which cross each other in the middle of the town: these and the other streets are all paved with basalt. The whole town is built of this sort of stone,

the dark color of which gives it a gloomy appearance. Formerly a place of some strength, Riom has still a small arsenal, but its earthen mound is planted with trees, and forms a promenade. Its only public structures worth notice are the theatre and fountains. Its trade is confined to hardware, linen, groceries, and the products of the surrounding country. Inhabitants 14,000. Fifty miles south by west of Moulins.

RI'OT, *n. s. & v. n.* } Old Fr. *riotte*; barb.  
 RI'OTER, } Lat. *riotum*. Tumult;  
 RI'OTISE, } uproar; wild or loose  
 RI'OTOUS, *adj.* } mirth: to riot is, to re-  
 RI'OTOUSLY, *adv.* } vel; 'luxuriate; be tu-  
 RI'OTUSNESS, *n. s.* } multuous: 'to run riot,'

to act without restraint or control: riotise is an obsolete synonyme of riot: the adjective, adverb, and noun substantive corresponding.

Let us walk honestly as in the day; not in rioting and drunkenness, *Romans* xiii. 13.

He that gathereth by defrauding his own soul, gathereth for others that shall spend his goods riotously. *Eccles.* xiv. 4.

From every work he challenged essoin

For contemplation sake; yet otherwise

His life he led in lawless riotise. *Spenser.*

What needs me tell their feasts and goodly guise, In which was nothing riotous nor vain. *Id.*

When his headstrong riot hath no curb,  
 When rage and hot blood are his counsellors,  
 When means and lavish manners meet together,  
 Oh! with what wings shall his affection fly  
 Tow'ard fronting peril and opposed decay.

*Shakespeare. Henry IV.*

When all our offices have been opprest

With riotous feeders,  
 I have retired me to a wasteful cock,  
 And set mine eyes at flow. *Shakespeare.*

Now he exacts of all, waster in delight,  
 Riots in pleasure, and neglects the law. *Daniel.*

All now was turned to jollity and game,  
 To luxury and riot, feast and dance. *Milton.*

John came neither eating nor drinking, that is, far from the diet of Jerusalem and other riotous places, but fared coarsely. *Browne.*

With them no riotous pomp nor Asian train,  
 T' infect a navy with their gaudy fears;  
 But war severely like itself appears. *Dryden.*

One man's head runs riot upon hawks and dice. *L'Estrange.*

Thy life a long dead calm of fixed repose:  
 No pulse that riots, and no blood that glows. *Pope.*

You never can defend his breeding,

Who, in his satyre's running riot,  
 Could never leave the world in quiet. *Swift.*

**RIOT**, in law. The riotous assembling of twelve persons, or more, and not dispersing upon proclamation, was first made high treason by stat. 3 and 4 Edw. VI. c. 5, when the king was a minor, and a change of religion had to be effected; but that statute was repealed by stat. 1 Mar. c. 1, among the other treasons created since the 25 Edw. III.; though the prohibition was in substance re-enacted, with an inferior degree of punishment, by stat. 1. Mar. stat. 2, c. 12, which made the same offence a single felony. These statutes specified and particularised the nature of the riots they were meant to suppress; as, for example, such as were set on foot with intention to offer violence to the privy council,

VOL. XVIII.

or to change the laws of the kingdom, or for certain other specific purposes; in which cases, if the persons were commanded by proclamation to disperse, and they did not, it was by the stat. of Mary made felony, but within the benefit of clergy; and also the act indemnified the peace officers and their assistants, if they killed any of the mob in endeavouring to suppress such riot. This act was made at first only for a year, and afterwards continued for queen Mary's life. And by stat 1 Eliz. c. 16, when a reformation in religion was to be once more attempted, it was revived and continued during her life also, and then expired. From the accession of James I. to the death of queen Anne it was never thought expedient to revive it; but in the first year of Geo. I. it was judged necessary, in order to support the execution of the act of settlement, to renew it, and at one stroke to make it perpetual, with large additions. For, whereas the former acts expressly defined and specified what should be accounted a riot, the stat. 1 Geo. I. c. 5, enacts generally, that if any twelve persons are unlawfully assembled to the disturbance of the peace, and any one justice of the peace, sheriff, under sheriff, or mayor of a town, shall think proper to command them by proclamation to disperse, if they contemn his orders, and continue together for one hour afterwards, such contempt shall be felony without benefit of clergy. And farther, if the reading of the proclamation be by force opposed, or the reader be in any manner wilfully hindered from the reading of it, such opposers and hinderers are felons without benefit of clergy; and all persons to whom such proclamation ought to have been made, and knowing of such hindrance, and not dispersing, are felons without benefit of clergy. There is the like indemnifying clause, in case any of the mob be unfortunately killed in the endeavour to disperse them, copied from the act of queen Mary. And, by a subsequent clause of the new act, if any person so riotously assembled, begin, even before proclamation, to pull down any church, chapel, meeting-house, dwelling-house, or out houses, they shall be felons without benefit of clergy. Riots and unlawful assemblies must have three persons at least to constitute them. An unlawful assembly is, when three or more do assemble themselves together to do an unlawful act, as to pull down enclosures, to destroy a warren, or the game therein; and part without doing it, or making any motion towards it. A riot is where three or more actually do an unlawful act of violence, either with or without a common cause or quarrel; as, if they beat a man, or hunt and kill game in another's park, chase, warren or liberty; or do any other unlawful act with force or violence; or even do a lawful act, as removing a nuisance, in a violent and tumultuous manner. The punishment of unlawful assemblies, if to the number of twelve, may be capital, according to the circumstances that attend it; but from the number of three to eleven is by fine and imprisonment only. The same is the case in riots and routs by the common law; to which the pillory in very enormous cases has been sometimes superadded. And by the stat. 13 Hen. IV. c. 17, any two justices,

2 R

together with the sheriff or under sheriff of the county, may come with the posse comitatus, if need be, and suppress any such riot, assembly, or rout, arrest the rioters, and record upon the spot the nature and circumstances of the whole transaction; which record alone shall be a sufficient conviction of the offenders. In the interpretation of which statute it hath been holden that all persons, noblemen, and others, except women, clergymen, persons decrepit, and infants under fifteen, are bound to attend the justices in suppressing a riot, upon pain of fine and imprisonment; and that any battery, wounding, or killing the rioters, that may happen in suppressing the riot, is justifiable.

**RIOUS ISLAND**, or **ROAHOOGA**, an island of the Pacific, about twenty-four miles in circumference, was discovered in 1792 by lieutenant Hergest, of the *Dædalus* store-ship. It is composed of steep and rugged rocks rising to a considerable height, and forming a lofty mountain in the middle. The western is the most fruitful side. Long. 139° 9' W., lat. 8° 54' S.

**RIP**, *v. a.* Sax. *prýpan*. To tear; lacerate; cut asunder by a continued stroke.

Thou wilt dash their children, and *rip* up their women with child. *2 Kings* viii. 12.

Let it be lawful for me to *rip* up to the very bottom, how and by whom your discipline was planted, at such time as this age we live in began to make first trial thereof. *Hooker*.

You *rip* up the original of Scotland. *Spenser*.  
You bloody Neros, *ripping* up the womb  
Of your dear mother England, blush for shame. *Shakspeare*.

Esculapius, because *ripped* from his mother's womb, was feigned to be the son of Apollo. *Hayward*.

They *ripped* up all that had been done from the beginning of the rebellion. *Clarendon*.

*Rip* this heart of mine  
Out of my breast, and shew it for a coward's. *Osway*.

The beast prevents the blow,  
And upward *rips* the groin of his audacious foe. *Dryden*.

The relations considering that a trial would *rip* up old sores, and discover things not so much to the reputation of the deceased, they dropt their design. *Arbuthnot*.

The conscious husband, whom like symptoms seize,  
Charges on her the guilt of their disease;  
Affecting fury acts a madman's part,  
He'll *rip* the fatal secret from her heart. *Granville*.

**RIPE**, *adj.*, *v. n.*, & *v. a.* } Sax. *ripe*; Belg.  
**RÍPEN**, *v. n.* & *v. a.* } *ryp*; Teut. *reif*.  
**RIPE'NESS**, *n. s.* } Brought to perfection in growth; mature; finished; complete; qualified: to ripe and ripen are used as synonyms both in the verb neuter and active forms, and mean to grow or make mature: the noun substantive corresponding.

Afore the sour grape is *ripening* in the flower. *Isaiah* xviii. 5.

Their fruit is improfitable, not *ripe* to eat. *Wisdom* iv. 5.

Beasts are in sensible capacity as *ripe* even as men themselves, perhaps more *ripe*. *Hooker*.

To this purpose were those harmonious tunes of psalms devised for us, that they, which are either in years but young, or touching perfection of virtue

as yet not grown to *ripeness*, might, when they thát they sing, learn. *Id.*

He was a scholar, and a *ripe* and good one. *Shakspeare*.

I by letters shall direct your course,  
When time is *ripe*. *Id. Henry IV.*

He is retired, to *ripe* his growing fortunes,  
To Scotland. *Shakspeare*.

There was a pretty redness in his lips,  
A little *riper* and more lusty red  
Than that mixed in his cheeks. *Id.*

Those happiest smiles,  
That played on her *ripe* lip, seemed not to know  
What guests were in her eyes, which parted thence,  
As pearls from diamonds dropt. *Id.*

This is the state of man; to-day he puts forth  
The tender leaves of hope, to-morrow blossoms,  
And bears his blushing honours thick upon him;  
The third day comes a frost, a killing frost;  
And when he thinks, good easy man, full surely  
His greatness is a *ripening*, nips his root;  
And then he falls as I do. *Id.*

This royal infant promises  
Upon this land a thousand thousand blessings.  
Which time shall bring to *ripeness*. *Id.*

Slubber not business for my sake, Bassanio;  
But stay the very *ripping* of the time. *Id.*  
The pricking of a fruit before it *ripeneth*, *ripes* the  
fruit more suddenly. *Bacon's Natural History*.

Though no stone tell thee what I was, yet thou,  
In my graves inside, see what thou art now;  
Yet thou'rt not so good, till us death lay  
To *ripe* and mellow there, we're stubborn clay. *Downe*.

Time, which made them their fame out-live,  
To Cowley scarce did *ripeness* give. *Denham*.  
So may'st thou live, till, like *ripe* fruit, thou drop  
Into thy mother's lap, or be with ease  
Gathered, not harshly plucked, for death mature. *Milton*.

I to manhood am arrived so near,  
And inward *ripeness* doth much less appear,  
That some more timely happy spirits indu'th. *Id.*  
At thirteen years old he was *ripe* for the universi-  
ty. *Fell*.

O early *ripe*! to thy abundant store,  
What could advancing age have added more? *Dryden*

When to *ripened* manhood he shall grow,  
The greedy sailor shall the seas forego. *Id.*  
While things were just *ripe* for a war, the can-  
tons, their protectors, interposed as umpires in the  
quarrel. *Addison*.

The genial sun  
Has daily, since his course begun,  
Rejoiced the metal to refine,  
And *ripened* the Peruvian mine. *Id.*  
They have compared it to the *ripeness* of fruits. *Wiseman*.

Little matter is deposited in the abscess, before it  
arrives towards its *ripeness*. *Sharp's Surgery*.

Melons on beds of ice are taught to bear,  
And strangers to the sun yet *ripen* here. *Granville*.  
Be this the cause of more than mortal hate,  
The rest succeeding times shall *ripen* into fate. *Pope*.

Here elements have lost their uses;  
Air *ripens* not, nor earth produces. *Swift*.

**RIPHAT**, or **RIPHATH**, the second son of Gomer, and grandson of Japhet. In most copies he is called Diphath in the Chronicles. The resemblance of the two Hebrew letters  $\gamma$  (*resh*) and  $\delta$  (*daleth*) is so great, that they are very often con-

founded. The learned are not agreed about the country that was peopled by the descendants of Riphath. Eusebius considers it to have been the country of the Sauromatæ; the Chronicon Alexandrinum that of the Garamantæ; Josephus Paphlagonia. Mela assures us that anciently the people of this province were called Riphatæi, or Riphaces; and others think he peopled the Montes Riphæi; and this opinion seems the most reasonable, because the other sons of Gomer peopled the northern countries towards Scythia, and beyond the Euxine Sea.

RIPLEY, an English alchymist of the fifteenth century. He published 1. A Compend of Alchymie, &c., and 2. Aurum Potabile, or The Universal Medicine. He died in 1490.

RIPLEY, a market town and parish in the West Riding of Yorkshire, situate on the river Nidd, four miles north-west from Knaresborough, and 215 north by west from London. Some few remains of a castle are still standing here, and the church is an ancient building. The place is noted for its abundant produce of the liquorice plant. Market on Friday.

RIPPON, a pleasant, well-built, and populous borough and market town of Yorkshire, in the West Riding; famous for its manufactures of hardware. It is an ancient town, noted in history long before the Roman conquest, and was famous for its religious houses. It has a magnificent church, with three lofty spires. In the days of popery this church was noted for a straight passage leading into a closely vaulted room, which could be made wider or narrower at pleasure, so as to admit or prevent the entrance of any one. This passage was called St. Wilfrid's Needle, and was used to try the chastity of any woman suspected of incontinence. The town is composed of several crooked lanes, there being but five regular built streets in the place. It sends two members to parliament. The market-place is accounted one of the finest squares of the kind in England, and is adorned with an obelisk, erected by John Aislabie, the chancellor of the exchequer in the reign of George I. Two extensive cotton mills have been erected of late years and employ a number of hands; and here are also annual and well attended races. It is seated on the Ure, or Yore; twenty-eight miles north-west of York, and 209 N. N. W. of London.

RISANO, a town of Austrian Dalmatia, at the head of the gulf of Cattaro, eight miles north of Cattaro. The inhabitants boast of having preserved the ancient Roman habits, and are certainly remarkable for their intrepidity. Population 1800.

RISBOROUGH, or MONKS'-RISBOROUGH, a market town and parish of Buckinghamshire, four miles and a half south-west from Wendover, and thirty-seven from London. It received the name of Monks'-Risborough from its being assigned to the monks of Canterbury, by Eschevine, bishop of Dorchester, and there was an adjoining parish called Prince's-Risborough, where, according to tradition, Edward the black prince had large possessions. Market on Saturday.

RISDON (Tristram), an English antiquary,

born near Great Torrington, in Devonshire, about 1580. He was educated at Oxford; after which he retired to his family seat at Winscot, where he published The History and Antiquities of Devonshire; of which many copies are extant. Edmund Curl, the bookseller, printed a mutilated edition of it in 1714, in 2 vols. 8vo. Risdon died in 1640, aged sixty.

RISE, *v. n.* & *n. s.* } Pret. rose; part. risen.  
RIS'EN, *adj.* } Sax. *rujan*; Belg. *rûsen*;  
Goth. *risa*. To get or grow up; ascend; spring; swell; begin; be excited or produced; increase; be revived from death: the noun substantive and adjective corresponding.

If the bright spot stay in his place, it is a rising of the burning. *Leviticus xiii. 21.*

If any man hate his neighbour, lie in wait, and rise up against him, and smite him mortally, and fleeth unto one of those cities, the elders of his city shall fetch him thence. *Deuteronomy.*

As wild asses in the desert, go they forth to their work, rising betimes for a prey. *Job xxiv. 5.*

He maketh the sun to rise on the evil and the good. *Matthew v.*

After I am risen again, I will go before you.

*Id. xxvii.*

As they 'gan his library to view

And antique registers for to advise,

There chanced to the prince's hand to rise

An ancient book. *Spenser.*

He, rising with small honour from Gunza, and fearing the power of the Christians, was gone.

*Knolles.*

Never a wife leads a better life than she does; do what she will; go to bed when she list; rise when she list. *Shakespeare.*

Some rise by sin, and some by virtue fall. *Id.*

It has its rise from the lazy admonitions of those who give rules, and propose examples, without joining practice with their instructions. *Id.*

If they rise not with their service, they will make their service fall with them. *Bacon.*

In leaping with weights, the arms are first cast backwards and then forwards, with so much the greater force; for the hands go backward before they take their rise. *Id.*

In the ordinary rises and falls of the voice, there fall out to be two becmolls between the unison and the diapason. *Id.*

The isle of *Æsa*, where the palace stands

Of the' early riser, with the rosy hands,

Active Aurora; where she loves to dance.

*Chapman.*

Ris not the consular men and left their places  
So soon as thou sat'st down; and fled thy side?

*Ben Jonson.*

That is to live,

To rest secure, and not rise up to grieve.

*Daniel's Civil War.*

Only he spoke, and every thing that is,  
Out of the fruitful womb of nothing rises. *Cowley.*

Such a rise, as doth at once invite

A pleasure, and a reverence from the sight.

*Denham.*

Raised so high, from 'hat convenient rise

She took her flight, and quickly reached the skies.

*Creech.*

Thy mansion wants thee, Adam, rise. *Milton.*

True in our fall,

False in our promised rising. *Id. Paradise Lost.*

Whether the sun

Rise on the earth, or earth rise on the sun. *Milton.*

High winds began to rise. *Id.*



At our heels all hell should *rise*,  
 With blackest insurrection. *Id.*  
 The stars of morn shall see him *rise*  
 Out of his grave. *Id.*  
 He affirmeth that tunny is fat upon the rising of  
 the Pleiades, and departs upon Arcturus.  
*Browne's Vulgar Errors.*  
 Your author always will the best advise,  
 Fall when he falls, and when he *riseth, rise.*  
*Roscommon.*  
 To *rise* i' the world,  
 No wise man that's honest should expect. *Otway.*  
 Indeed you thanked me; but a nobler gratitude  
*Rose* in her soul; for from that hour she loved me.  
*Id.*

Phœbus! stay;  
 The world to which you fly so fast,  
 From us to them can pay your haate  
 With no such object, and salute your *rise*  
 With no such wonder, as De Mornay's eyes.  
*Waller.*

Upon a breach with Spain, must be considered the  
 present state of the king's treasure, the *rise* or fall  
 that may happen in his constant revenue by a Spa-  
 nish war. *Temple.*

With Vulcan's rage the *rising* winds conspire,  
 And near our palace rolls the flood of fire. *Dryden.*  
 The hill submits itself

In small descents, which do its height beguile;  
 And sometimes mounts, but so as billows play,  
 Whose *rise* not hinders, but makes short our way.  
*Id.*

Bullion is *risen* to six shillings and five pence the  
 ounce; i. e. that an ounce of uncoined silver will  
 exchange for an ounce and a quarter of coined silver.  
*Locke.*

Ash, on banks or *rising* grounds near rivers, will  
 thrive exceedingly. *Mortimer's Husbandry.*

All wickedness taketh its *rise* from the heart, and  
 the design and intention with which a thing is done,  
 frequently discriminates the goodness or evil of the  
 action. *Nelson.*

From such an untainted couple, we can hope to  
 have our family *rise* to its ancient splendour of face,  
 air, countenance, and shape. *Tatler.*

A thought *rose* in me, which often perplexes men  
 of contemplative natures. *Spectator.*

Numidia's spacious kingdom lies  
 Ready to *rise* at its young prince's call. *Addison.*  
 The great duke *riseth* on them in his demands, and  
 will not be satisfied with less than a hundred thou-  
 sand crowns, and a solemn embassy to beg pardon.  
*Id. on Italy.*

Those, that have been raised by some great minis-  
 ter, trample upon the steps by which they *rise* to  
 rival him. *South.*

If two plane polished plates of a polished looking-  
 glass be laid together, so that their sides be parallel,  
 and at a very small distance from one another, and  
 then their lower edges be dipped into water, the wa-  
 ter will *rise* up between them. *Newton.*

No more shall nation against nation *rise*,  
 Nor ardent warriors meet with hateful eyes. *Pope.*

The bishops have had share in the gradual *rise* of  
 lands. *Swift.*

The archbishop received him sitting; for, said he,  
 I am too old to *rise.* *Earl of Orrery.*

**RISIBLE**, *adj.* Fr. *risible*; Lat. *risibilis*.  
 Having the faculty or power of laughter, or of  
 exciting laughter.

How comes lowness of stile to be so much the  
 propriety of satyr that without it a poet can be no  
 more a satyrist, than without *risibility* he can be a  
 man? *Dryden.*

We are in a merry world, laughing is our busi-  
 ness; as if, because it has been made the definition of  
 man that he is *risible*, his manhood consisted in no-  
 thing else. *Government of the Tongue.*

Whatever the philosophers may talk of their *risi-  
 bility*, neiging is a more noble expression than  
 laughing. *Arbuthnot.*

**RISK**, *n. s. & v. a.* } Fr. *risque*; Span. *ries-  
 Risk'ER.* } *go.* Hazard; danger;  
 chance of harm: to place in danger; risker cor-  
 responding.

He thither came, t' observe and smook  
 What courses other *riskers* took. *Butler.*  
 Some run the *risk* of an absolute ruin for the gain-  
 ing of a present supply. *L'Estrange.*

When an insolent despiser of discipline, nurtured  
 into contempt of all order by a long *risk* of licence,  
 shall appear before a church governor, severity and  
 resolution are that governor's virtues. *South.*

Who would hope new fame to raise,  
 Or *risk* his well-established praise,  
 That, his high genius to approve,  
 Had drawn a George, or carved a Jove? *Addison.*

By allowing himself in what is innocent, he would  
 run the *risk* of being betrayed into what is not so.  
*Atterbury.*

An innocent man ought not to run an equal *risk*  
 with a guilty man. *Clarissa.*

**RITCHIE** (Joseph), an English traveller,  
 one of the unfortunate victims of the passion for  
 African discovery, was born at Otley in York-  
 shire, and obtained a situation in the office of  
 the English consul at Paris, where he first be-  
 came acquainted with the plans of the African  
 association. In conjunction with captain G. F.  
 Lyon he went to Tripoli; and, in March 1819,  
 the party set out for Mourzouk, in Fezzan, under  
 the escort of Mukni the bey. They resided at  
 Mourzouk some months in distress, arising from  
 the want of funds, and the treacherous conduct  
 of the bey. To this hardship and vexation Mr.  
 Ritchie fell a sacrifice in November of this year.  
 Captain Lyon returned to England, and in 1821  
 published A Narrative of Travels in Northern  
 Africa, in 1818, 19, and 20, accompanied by  
 Geographical Notices of Soudan, and of the  
 Course of the Niger, 4to.

**RITE**, *n. s.* } Fr. *rit*; Lat. *ritus*.  
**RITUAL**, *adj. & n. s.* } Solemn act of religion;  
**RITUALIST**, *n. s.* } external observance;  
 ritual is solemnly ceremonious; a book of solemn  
 ceremonies: ritualist, he who is skilled in rit-  
 uals.

The ceremonies, we have taken from such as were  
 before us, are not things that belong to this or that  
 sect, but they are the ancient *rites* and customs of the  
 church. *Hooker.*

Is it by God consecrated into a sacrament, a  
 holy *rite*, a means of conveying to the worthy re-  
 ceiver the benefits of the body and blood of Christ.  
*Hammond's Fundamentals.*

When the prince her fun'ral *rites* had paid,  
 He ploughed the Tyrrhene seas. *Dryden.*

A heathen *ritual* could not instruct a man better  
 than these several pieces of antiquity in the particu-  
 lar ceremonies, that attended different sacrifices.

*Addison's Remarks on Italy.*  
 Instant I bade the priests prepare  
 The *ritual* sacrifice, and solemn prayer. *Prior.*  
 If to tradition were added certain constant *ritual*  
 and emblematical observances, as the emblems were

expressive, the memory of the thing recorded would remain.

**RITSON** (Joseph), a celebrated antiquary, was born in 1752, at Stockton-upon-Tees, in the county of Durham, and was brought up to the profession of the law. But his literary enquiries were by no means confined within the limits of his profession; and he was, perhaps, the most successful of those persons by whom the investigation of ancient English literature and antiquities was cultivated in the latter part of the eighteenth century. He died October, 1803. The following is a list of Mr. Ritson's publications:— 1. Observations on Johnson's and Steevens's Edition of Shakspeare; 2. Quiss Modest, in defence of ditto; 3. Cursory Criticisms on Malone's Edition of Shakspeare; 4. Observations on Warton's History of English Poetry; 5. Descent of the Crown of England, in a large Sheet; 6. Spartan Manuel; 7. Digest of the Proceedings of the Savoy Court; 8. Office of Constable explained; 9. Jurisdiction of the Court Leet; 10. A Collection of English Songs, 3 vols.; 11. Ditto of Scottish Songs, 2 vols.; 12. English Anthology, 3 vols.; 13. Minot's poems, 2 vols.; 14. Metrical Romances, 3 vols.; 15. Bibliographia Poetica; and, 16. Treatise on Abstinence from Animal Food.

**RITTEBERG**, a small principality of the government of Minden, belonging to Prussia. It lies on the Eras, contains an area of sixty-five square miles, and has about 12,000 inhabitants, chiefly Catholics. A number of these are spinners and weavers; and the district requires an annual import of provisions.

**RITTENHOUSE** (David), an eminent American mathematician, was the son of a farmer in Pennsylvania. His parents put him apprentice to a watch-maker; and astronomy became the object of his enquiries; and, by procuring a few books on the subject, he soon made great progress in the science. The first public display he gave of his ingenuity was in 1768, when he completed his New Orrery, which gave universal satisfaction; and the trustees of the college of Philadelphia conferred on him the honorary degree of M.A. Not long after this he communicated, by his friend Dr. Smith, to the American Philosophical Society, a Projection of the transit of Venus, calculated from Halley's Tables; in consequence he was appointed by them, with several others, to make the necessary preparations for observing the transit at his house at Norristown. This transit happened on the 3d of June, 1769; and Mr. Rittenhouse obtained the applause of the astronomers of Europe, who esteemed his observation of this singular phenomenon extremely accurate and ingenious. After the American war he successively filled the offices of treasurer of the state of Pennsylvania, and director of the national mint. He succeeded the venerable Franklin as president of the American Philosophical Society, which office he filled with high reputation. He died in June 1796.

**RITTERHUSIUS** (Conrad), a learned German civilian, born at Brunswick in 1560. He was professor of civil law at Altdorf, and published a variety of works, particularly as a civilian; together with an addition of Oppian in Greek and Latin: he was moreover an excellent critic;

his notes upon many eminent authors having been inserted in the best editions of them. He died in 1613.

**RITZEBUTTEL**, a bailiwick belonging to Hamburg, containing the harbour of Cuxhaven, and lying near the North Sea, between the Elbe and the Weser. Its area, without including the small island of Neuwerk, is twenty square miles, and its population 4000. It is very fertile.

**RITZEBUTTEL**, the chief place of the above bailiwick, is a neat small town, with 1500 inhabitants. Fifty-four miles W. N. W. of Hamburg, and one south of Cuxhaven.

**RIVAGE**, *n. s.* French *rivage*. A bank; a coast. Not in use.

Think

You stand upon the *rivage*, and behold  
A city on the' inconstant billows dancing;  
For so appears this fleet. *Shakspeare.*

**RIVAL**, *n. s. v. a. & c.* Lat. *rivalis*. A competitor; one who is in pursuit of the same thing which another man pursues: to oppose; be competitors: the noun-substantives corresponding.

She saw her father was grown her adverse party,  
and yet her fortune such as she must favour her  
*rival.* *Sidney.*

France and Burgundy,  
Great *rivals* in our younger daughter's love. *Shakspeare.*

Had I but the means  
To hold a *rival* place with one of them,  
I should be fortunate. *Id.*

Burgundy,  
We first address'd toward you, who with this king  
Have *rival'd* for our daughter. *Id.*

Oh love! thou sternly dost thy pow'r maintain,  
And wilt not bear a *rival* in thy reign;  
Tyrants and thou all fellowship disdain. *Dryden.*

You bark to be employed,  
While Venus is by *rival* dogs enjoyed. *Id.*  
Ambitious fool! with horny hoofs to pass  
O'er hollow arches of resounding brass;  
To *rival* thunder in its rapid course,  
And imitate inimitable force. *Id. Æneis.*

Those that have been raised by the interest of  
some great minister, trample upon the steps by which  
they rise, to *rival* him in his greatness, and at length  
step into his place. *South.*

It is the privilege of posterity to set matters right  
between those antagonists, who, by their *rivalry* in  
greatness, divided a whole age. *Addison.*

Your *rival's* image in your worth I view;  
And what I lov'd in him, esteem in you. *Granville.*  
O thou, too great to *rival* or to praise,  
Forgive, lamented shade, these duteous lays.  
Lee had thy fire, and Congreve had thy wit;  
And copyists here and there, some likeness hit;  
But none possessed thy graces, and thy ease;  
In thee alone 'twas natural to please! *Harte.*

A man truly zealous for his fraternity, is never so  
irresistibly flattered, as when some *rival* calling is  
mentioned with contempt. *Johnson.*

**RIVE**, *v. a. & v. n., preter. rived; part. riven.*  
Sax. *ryft*, broken; Fr. *river*, to rivet. To split;  
cleave; to divide by a blunt instrument: to be split.

At his haughty helmet  
So hugely struck, that it the steel did *rive*  
And cleft his head. *Spenser.*

Through *riens* clouds and melted firmament,  
The fierce three-forked engine making way,  
Both lofty towers and highest trees hath rent. *Id.*  
O Cicero!

I have seen tempests, when the scolding winds  
Have *rieced* the knotty oaks; but ne'er till now  
Did I go through a tempest dropping fire.

*Shakespeare.*

Ten thousand French have ta'en the sacrament,  
To *rise* their dangerous artillery  
Upon no christian soul but English Talbot. *Id.*

The neighbouring forests, formerly shaken and  
*riees* with the thunder-bolts of war, did envy the  
sweet peace of Druina. *Howel's Vocal Forest.*

As one he stood, escap'd from cruel fight,  
Sore toiled, his *riees* arms to havock hewn. *Milton.*

Had I not been blind, I might have seen  
You *riees* oak, the fairest of the green. *Dryden.*

Let it come;  
Let the fierce lightning blast, the thunder *riees* me.

*Rowe.*

Freestones *riees*, splits, and breaks in any direction.  
*Woodward.*

RIV'EL, *v. a.* Sax. *gēripelō*; Belg. *kuyselen*,  
rumbled. To contract into wrinkles. Not in use.

Then drooped the fading flowers, their beauty fled,  
And closed their sickly eyes and hung the head,  
And, *rieeled* up with heat, lay dying in their bed.

*Dryden.*

Alam stipticks, with contracting power,  
Shrink his thin essence like a *rieeled* flower. *Pope.*

RIVER, *n. s.* Fr. *riviere*; Lat. *rivus*.  
RIVER-DRAGON, *n. s.* A land-current of water;  
RIVERET, a considerable stream  
RIVER-GOD, running into the sea: a  
RIVER-HORSE, river-dragon is a poetical  
RIVULET, name for the crocodile:

*riveret*: *riveret* and *rivulet* diminutives of *river*:  
*river-god*, the tutelary deity of a river: *river-horse*,  
the hippopotamus.

It is a most beautiful country, being stored throughout  
with many goodly *riees* replenished with all sorts  
of fish. *Spenser.*

Bringing all their *riverets* in,  
There ends; a new song to begin. *Drayton.*

Thus with ten wounds  
The *river-dragon*, tamed at length, submits  
To let his sojourners depart.

*Milton's Paradise Lost.*

Rose,  
As plants ambiguous between sea and land,  
The *river-horse* and scaly crocodile. *Milton.*

By fountain, or by shady *rieelet*,  
He sought them. *Id.*  
The first of these *riees* has been celebrated by the  
Latin poets for the gentleness of its course, as the  
other for its rapidity. *Addison on Italy.*

I saw the *rieelet* of Salforata, formerly called Al-  
bula, and smell the stench that arises from its water,  
which Martial mentions. *Id.*

The veins, where innumerable little *rieelets* have  
their confluence into the common channel of the  
blood. *Bentley.*

His wig hung as strait as the hair of a *river-god*  
rising from the water. *Arbutnot and Pope.*

I would have a man's wit rather like a fountain,  
that feeds itself invisibly, than a *riee*, that is sup-  
plied by several streams from abroad. *Swift.*

RIV'ET, *n. s. & v. a.* Fr. *river*, to rivet; Ital.  
*ribato*. A fastening pin clenched at both ends:  
to drive in or clench a rivet; fasten with a rivet;  
fasten strongly.

The armourers accomplishing the knights,  
With busy hammers closing *riees* up,  
Give dreadful note of preparation. *Shakespeare.*

You were to blame to part with  
A thing stuck on with oaths upon your fingers,  
And *rieeeted* with faith unto your flesh. *Id.*

This man,

If all our fire were out, would fetch down new  
Out of the hand of Jove; and *riees* him  
To Caucasus, should he but frown. *Ben Jonson.*

What one party thought to *riees* to a settledness,  
by the influence of the Scots, that the other rejects.  
*King Charles.*

Thus hath God not only *rieeeted* the notion of him-  
self into our natures, but likewise made the belief  
of his being necessary to the peace of our minds and  
happiness of society. *Tillotson.*

The verse in fashion is, when numbers flow  
So smooth and equal, that no sight can find  
The *riees* where the polished piece was joined.

*Dryden.*

Till fortune's fruitless spite had made it known,  
Her blows not shook but *rieeeted* his throne. *Id.*

Where we use words of a loose and wandering sig-  
nification, hence follow mistake and error, which  
those maxims, brought as proofs to establish proposi-  
tions, wherein the terms stand for undetermined  
ideas, do by their authority confirm and *riees*.

*Locke.*

In *rieeeting*, the pin you *riees* in should stand up-  
right to the place you *riees* it upon; for, if it do not  
stand upright, you will be forced to set it upright  
after it is *rieeeted*. *Mason.*

They provoke him to the rage  
Of fangs and claws, and, stooping from your horse,  
*Riees* the panting savage to the ground. *Addison.*

*Riees* and nail me where I stand, ye powers!  
*Congreve.*

A similitude of nature and manners, in such a de-  
gree as we are capable of, must tie the holy knot,  
and *riees* the friendship between us. *Atterbury.*

This instrument should move easy upon the *riees*.  
*Sharp.*

RIVINA, in botany, American nightshade, a  
genus of the monogynia order, and tetrandria  
class of plants. The perianth is four-leaved,  
colored, and permanent; the leaflet oblong-egged  
and obtuse: cor. none. There are four or eight  
filaments, shorter than the calyx, approaching by  
pairs, permanent: the antheræ are small. The  
germ is large and roundish; the style very short;  
the stigma simple and obtuse. The berry is  
globular, sitting on the green reflected calyx,  
one-celled, with an incurved point. There is  
one rugged seed. This plant is called *solonoides*  
by Tournefort, and *piercea* by Miller. It grows  
naturally in most of the islands of the West  
Indies. The juice of the berries of the plant  
will stain paper and linen of a bright red color,  
and many experiments made with it to color  
flowers have succeeded extremely well in the  
following manner: the juice of the berries was  
pressed out, and mixed with common water,  
putting it into a phial, shaking it well together  
for some time till the water was thoroughly  
tinged; then the flowers, which were white and  
just fully blown, were cut off, and their stalks  
placed into the phial; and in one night the  
flowers have been finely variegated with red: the  
flowers on which the experiments were made  
were the tuberoses and the double white nar-  
cissus.

**RIVOLI**, a town of Piedmont, Italy, at the foot of the Alps, on the great road which leads over Mount Cenis into Savoy. It has some manufactures of linen, woollens, and silk. On an eminence stands a castle, in which Victor Amadeus II. of Sardinia, after having abdicated his throne in favor of his son, and endeavoured to resume it, died, in 1732, a state prisoner. The prospect from this eminence, and in particular the view of Turin, through a spacious alley of trees, is most imposing. Population 5100. Nine miles west of Turin.

**RIVOLI**, a small place in the north-east of Lombardy, on the Adige, twelve miles north-west of Verona. It is only remarkable as the scene of one of Buonaparte's victories. At Arcole, in the preceding November, his plans had been repeatedly baffled by the Austrians; but here they had complete success (14th and 15th January, 1797) both on the field and in the pursuit.

**RIZZIO** (David), an Italian musician, who about 1563 attended the Piedmontese ambassador to Scotland, where, by his professional skill, he obtained great favor with Queen Mary. She appointed him her French secretary, and showed him such marks of distinction as gave offence to lord Darnley and other nobles, who, with great brutality, assassinated him in her presence. See **MARY** and **SCOTLAND**. Tradition assigns to Rizzio the amelioration, not to say the invention, of the Scottish music; and it is unquestionable that his skill in the performance of the national melodies on the lute tended not a little to their general improvement and popularity; but many of the airs which have been ascribed to Rizzio, as Cowden Knowes, Gala Water, and others, are easily traced to more remote periods.

**ROACH**, *n. s.* From Lat. *rutillus*, red-haired. A river fish.

A roach is a fish of no great reputation for his dainty taste: his spawn is accounted much better than any other part of him: he is accounted the water sheep for his simplicity and foolishness; and it is noted that roaches recover strength, and grow in a fortnight after spawning.

*Walton's Angler.*

If a gudgeon meet a roach,

He dare not venture to approach!

Yet still he leaps at flies.

*Swift.*

**ROAD**, *n. s.* Sax. *rað*; Fr. *rade*, *route*. From **RIDE**. Properly a horse or carriage way; large way; path; inroad: place for ships to anchor in; journey; course.

About the island are many roads, but only one harbour.

*Sandy's Journey.*

Cason was desirous of the spoil, for he was, by the former road into that country, famous and rich.

*Knolles.*

I should be still

Peering in maps for ports and roads;

And every object that might make me fear

Misfortune to my ventures.

*Shakespeare.*

The Volscians stand

Ready, when time shall prompt them, to make road Upon's again.

*Id. Coriolanus.*

With easy roads he came to Leicester,

And lodged in the abbey.

*Id. Henry VIII.*

The king of Scotland, seeing none came in to Perkin, turned his enterprize into a road, and wasted Northumberland with fire and sword.

*Bacon.*

Would you not think him a madman, who, whilst

he might easily ride on the beaten road way, should trouble himself with breaking up of gaps?

*Suckling.*

To God's eternal house direct the way,

A broad and ample road.

*Milton.*

He from the east his flaming road begins.

*Id.*

The liberal man dwells always in the road.

*Fell.*

To be indifferent whether we embrace falsehood or truth is the great road to error.

*Locke.*

In all our journey through the Alps, as well when we climbed as when we descended them, we had still a river running along with the road.

*Addison.*

Could stupid atoms, with impetuous speed,

By different roads and adverse ways proceed,

That there they might encounter, here unite.

*Blackmore.*

Some taken from their shops and farms, others from their sports and pleasures; these at suits of law, those at gaming tables; some on the road, others at their own fire-sides.

*Law.*

**ROAD**, in navigation, a bay, or a place of anchorage, at some distance from the shore, whither ships or vessels occasionally repair to receive intelligence, orders, or necessary supplies; or to wait for a fair wind, &c. The excellence of a road consists chiefly in its being protected from the reigning winds and the swell of the sea; in having a good anchoring-ground, and being at a competent distance from the shore. Those which are not sufficiently enclosed are termed open roads.

A ROAD is an open way, or public passage, forming a communication between one place and another. Of all the people in the world, the Romans took the most pains in forming roads; and the labor and expenses they were at in rendering them spacious, firm, straight, and smooth, are incredible. They usually strengthened the ground by ramming it, laying it with flints, pebbles, or sands, and sometimes with a lining of masonry, rubbish, bricks, &c., bound together with mortar. In some places in the cidevant Lionnois, F. Menestrier observes that he has found huge clusters of flints cemented with lime, reaching ten or twelve feet deep, and making a mass as hard and compact as marble; and which, after resisting the injuries of time for 1600 years, is still scarcely penetrable by all the force of hammers, mattocks, &c.; and yet the flints it consists of are not bigger than eggs. The most noble of the Roman roads was the Via Appia, which was carried to such a vast length that Procopius reckons it five days' journey to the end of it, and Lipsius computes it at 350 miles: it is twelve feet broad, and made of square free-stone, generally a foot and a half on each side; and, though this has lasted for above 1800 years, yet in many places it is several miles together as entire as when it was first made. The ancient roads are distinguished into military, subterraneous roads, &c. The military roads were grand roads, formed by the Romans for marching their armies into the provinces of the empire; the principal of these Roman roads in England are Watling Street, Ikonild Street, Foss Way, and Erminage Street. Double roads, among the Romans, were roads for carriages, with two pavements, the one for those going one way, and the other for those returning the other: these were separated from

each other by a causeway raised in the middle, paved with bricks, for the conveniency of foot-passengers; with borders and mounting stones from space to space, and military columns to mark the distance. Subterraneous roads are those dug through a rock, and left vaulted; and that of Puzzuoli near Naples, which is nearly half a league long, is fifteen feet broad, and as many high.

**MODERN ROADS.**—If the modern roads of Great Britain, and particularly those of England, do not as yet equal the most firm and durable of the ancient undertakings of this kind, it cannot be from the want of attention to the subject, either on the part of the legislature or the people. Our turnpike acts would of themselves make an ample volume; parliamentary enquiries into the general subject of road-making, as well as into its local applications, have often been adverted to; and commissioners for carrying into effect the decisions of the national wisdom comprise the names of almost every respectable squire and beneficed clergyman (!) and lawyer of the country.

M. Dupin, the ablest perhaps of modern writers on the commercial power of England, is far more enamoured with our road-making system than we can profess ourselves to be; he calculates that in the South of England alone we have an extent of public road, unequalled for its conveniences, that measures 46,000 leagues, and attributes it entirely to the well organised public spirit of the country. He contrasts in this respect the conduct of the British government, too, with that of France: the former not only granting the inhabitants a credit and funds, but leaving them to carry on themselves those works in which they are so materially interested; whilst in the latter the government obliges the inhabitants to pour their funds into its own treasury, to enable it to execute after its own manner, and when it shall seem good in its own eyes, that which concerns only the governed. 'How very far,' he says, 'are we from participating in the spirit of the administration and the parliament of Great Britain! We, who scarcely confide to the zeal of the inhabitants the repair of a village foot-path! We, who, before a basket of pebbles can be thrown upon the smallest departmental road, require imperatively that the future expense of this basketful shall be carried to the budget of the arondissement, then to that of the département, then submitted to the grand council of bridges and highways, sitting in a bureau at Paris, at the distance of 200 leagues from the situation of the work!'

He holds up to deserved ridicule the '*lenteurs savantes d'une comptabilité profonde,*' and the '*formalités bureaucratiques,*' which must be encountered before a public work of any description can be undertaken in France; the consequences of which are, that, with a strong corps of engineers *des ponts et chaussées* scattered over every part of the country, the few new works which are commenced proceed with all imaginable leisure, and the old ones are suffered gradually to decay. Matters of this kind, he says, are very differently managed in England. There houses, ships, carriages, and machines, are kept constantly in the best condition, and have an

appearance of freshness, neatness, nay, of brilliancy, which is only adopted partially, and that even by a small number of people, on the continent. It is remarkable, he adds, that the most economical nations, and those the most enlightened as to their pecuniary interests, such as the Dutch, the Swedes, and the English, adopt, with common consent, the system of constant repair; while the Italians, the Portuguese, the Spaniards, &c., the worst calculators, and the most improvident, wait generally till an edifice falls into ruins before they think of beginning to repair it. It is the same in England, he observes, with regard to the roads; they are habitually kept solid, smooth, and easy, equally economical for the transport of commerce, and the convenience and expedition of travelling. But in France, 'even in the midst of profound peace,' says M. Dupin, 'scarcely can the government be prevailed upon to assign, for the maintenance of our roads, the third part of the sums which are furnished by the inhabitants of England alone—a country that does not equal in surface a third part of France.'

All this may contribute to put our readers in good humor with what is often a dry and dusty subject; but, while we shall shortly endeavour to do justice to the real modern improvements in road-making, we conceive that this writer admires, through ignorance of its details, some of the worst parts of our system. It is a dear and bad system, and a third part of the immense expenditure it involves would appear fully equal, on a better plan of administration, to accomplish the complete intersection of the country with good roads. The surveyor of parish roads is chosen from ten men named by a vestry meeting; or, if necessary, more than one are appointed, the selection being in the justices at the quarter-sessions. The works and the money are under the management of the surveyor, and the control is in the local magistracy. A surveyor may perform the office gratuitously, but it is in the power of the parish to name and pay a salaried and professional one. The business is neglected by all; and it is doubly neglected when the commissioners are numerous, or it falls into the hands of some one who makes an interest for himself, in power or patronage, or something else; or, finally, every thing is transacted by an attorney, not always the most honorable member of his profession. As to hired surveyors, their collusions with the contractors are numerous; and while the wretched but cunning people who form vestries contrive to waste and spoil the funds, from the spoil of which they all in turn contrive to derive a profit, there is either no efficient control, or there is no control at all, as the accounts are passed under the direction of the attorney, himself dependent on the vestry and the parish for his favor and his profits. It is unquestionable that double the money is often raised for these roads that would be required under a prudent direction, free from all local interests.

Bergman quotes this general view of the subject; we shall extract from M. Dupin a passage grounded on the recent parliamentary enquiries. It is introduced by the following:

Table of the public roads of England, their length, and the cost of repairing them.

Public Carriage Roads in England.	Years ending in October.		
	1812.	1813.	1814.
	Miles.	Miles.	Miles.
Paved Streets and Turnpike Roads . . . . .	19,114	19,132½	19,178
Other Roads . . . . .	95,105	95,142½	95,184
<b>Total length . . . . .</b>	<b>114,219</b>	<b>114,275</b>	<b>114,362</b>
Contributions in labor . . . . .	£515,508	539,522	551,241
Contributions in money . . . . .	271,512	276,947	287,059
Taxes levied for the roads . . . . .	570,754	613,604	621,512
<b>Total . . . . .</b>	<b>£1,357,774</b>	<b>1,430,073</b>	<b>1,459,812</b>
Expense of preparing documents, &c.	21,499	26,252	25,700

Thus it appears that the average annual expenses of all the roads in England were, from 1811 to 1814, as follows:—

Contributions in labor . . . . .	£535,423
Ditto in money . . . . .	278,506
Sums raised by rate . . . . .	601,954
	£1,415,883

This gives us £12 7s. 6d. for the average annual expense of maintaining each mile of open road. In this calculation I have deducted,' says our author, 'from the total amount of the expense of road labor, the three days' labor which is allowed for turnpike roads; while six are allowed for open parish roads.

According to a report made to the house of commons on the 10th of June, 1821, the total amount of the sums levied in a single year on turnpike roads amounts to £970,618. This gives the average value of £47 18s. for the support of each mile of paved street and turnpike road. By adding the contributions in labor, the expense will amount to about £51 per mile. This revenue, immense as it is, is not sufficient for the construction of new roads, and the support of those that are already established. The different trusts have contracted debts, for which the rentals of each county are responsible. The total amount of the debts, at the period of the enquiry of which the report to which we have above alluded gives the result, was £3,874,254, that is to say, that these debts then equalled four years' revenue. It is affirmed that if the same calculation were made for Wales, Scotland, and Ireland, the general amount of the debt of the turnpike roads would amount to £7,000,000 sterling.—vol. i. p. 86.

The fact is that our modern improvements have been introduced in despite of a bad system—and, in their most decided feature, the simple methods of Mr. M'Adam exhibit the triumph of real genius and intelligence over cumbrous contrivances to make bad roads—and unmake good ones, that surveyors and inspectors may be paid.

1. *Of the purposes of roads and of laying down the line.*—Roads, rivers, and canals have been called the veins and arteries of a country; all its other improvements flow and circulate by

means of them. Our legal system respecting them dates from the reign of Charles II., but it was not until the middle of the last century that scientific enquiry was directed toward them.

Before carriages of burden were generally used, little more was required than a hard horse path. All marshy grounds were therefore shunned, and the inequality or circuit of the road was of much less consequence than when carriages, instead of pack-horses, began to be employed. When carriages were first employed, they probably were light and narrow, and did not require to have roads of any considerable breadth. And, when these had once been traced, indolence and habit prevented any great exertions to lay them out in better lines. Heavier carriages and greater traffic made wider and stronger roads necessary; the ancient track was pursued; ignorance and want of concert in the proprietors of the ground, and, above all, the want of some general effective superintending power, continued this wretched practice. At length turnpikes were established, and laws passed investing magistrates with authority to alter established lines, so that now the chief obstacle to the improvement of the lines of public roads is the expense.

In laying out roads, observes Mr. Loudon, a variety of circumstances require to be taken into consideration; but the principal are evidently their line or direction, and its inclination to the horizon. The most perfect line, according to Marshall, is that which is straight and level. But this is to be drawn in a country only which is perfectly flat, and where no obstructions lie in the way: joint circumstances that rarely happen. Where the face of the country, between two points or places to be connected by a road, is nearly but not quite level, by reason of gentle swells which rise between them, a straight line may be perfect,—may be the most eligible, under these circumstances. But where the intervening country is broken into hill and dale, or if one ridge of hill only intervenes, a straight line of carriage road is seldom compatible with perfection. In this case, which is nearly general, the best skill of the surveyor lies in tracing the midway between the straight and the level line. The line of perfection, for agricultural

each other by a causeway raised in the middle, paved with bricks, for the conveniency of foot-passengers; with borders and mounting stones from space to space, and military columns to mark the distance. Subterraneous roads are those dug through a rock, and left vaulted; and that of Puzzuoli near Naples, which is nearly half a league long, is fifteen feet broad, and as many high.

**MODERN ROADS.**—If the modern roads of Great Britain, and particularly those of England, do not as yet equal the most firm and durable of the ancient undertakings of this kind, it cannot be from the want of attention to the subject, either on the part of the legislature or the people. Our turnpike acts would of themselves make an ample volume; parliamentary enquiries into the general subject of road-making, as well as into its local applications, have often been adverted to; and commissioners for carrying into effect the decisions of the national wisdom comprise the names of almost every respectable squire and beneficed clergyman (!) and lawyer of the country.

M. Dupin, the ablest perhaps of modern writers on the commercial power of England, is far more enamoured with our road-making system than we can profess ourselves to be; he calculates that in the South of England alone we have an extent of public road, unequalled for its conveniences, that measures 46,000 leagues, and attributes it entirely to the well organised public spirit of the country. He contrasts in this respect the conduct of the British government, too, with that of France: the former not only granting the inhabitants a credit and funds, but leaving them to carry on themselves those works in which they are so materially interested; whilst in the latter the government obliges the inhabitants to pour their funds into its own treasury, to enable it to execute after its own manner, and when it shall seem good in its own eyes, that which concerns only the governed. 'How very far,' he says, 'are we from participating in the spirit of the administration and the parliament of Great Britain! We, who scarcely condescend to the road of the inhabitants the repair of a village foot-path! We, who, before a basket of pebbles can be thrown upon the smallest departmental road, require imperatively that the future expense of this basketful shall be carried to the budget of the arrondissement, then to that of the department, then submitted to the grand council of bridges and highways, sitting in a bureau at Paris, at the distance of 200 leagues from the situation of the work!'

He holds up to deserved ridicule the '*lenteurs savantes d'une comptabilité profonde*,' and the '*normalités bureaucratiques*,' which must be encountered before a public work of any description can be undertaken in France: the consequences of which are, that, with a string of engineers des routes et chaussées scattered over every part of the country, the few new works which are commenced proceed with all imaginable leisure, and the old ones are suffered gradually to decay. Mirrors of this kind, he says, are never differently managed in England. There houses, ships, carriages, and machines, are kept constantly in the best condition, and have an

appearance of freshness, neatness, nay, of brilliancy, which is only adopted partially, and that even by a small number of people, on the continent. It is remarkable, he adds, that the most economical nations, and those the most enlightened as to their pecuniary interests, such as the Dutch, the Swedes, and the English, adopt, with common consent, the system of constant repair; while the Italians, the Portuguese, the Spaniards, &c., the worst calculators, and the most improvident, wait generally till an edifice falls into ruins before they think of beginning to repair it. It is the same in England, he observes, with regard to the roads; they are habitually kept solid, smooth, and easy, equally economical for the transport of commerce, and the convenience and expedition of travelling. But in France, 'even in the midst of profound peace,' says M. Dupin, 'scarcely can the government be prevailed upon to assign, for the maintenance of our roads, the third part of the sums which are furnished by the inhabitants of England alone—a country that does not equal in surface a third part of France.'

All this may contribute to put our readers in a good humor with what is often a dry and dusty subject; but, while we shall shortly endeavour to do justice to the real modern improvements in road-making, we conceive that this writer admires, through ignorance of its details, some of the worst parts of our system. It is a dear and bad system, and a third part of the immense expenditure it involves would appear fully equal, on a better plan of administration, to accomplish the complete intersection of the country with good roads. The surveyor of parish roads is chosen from ten men named by a vestry meeting; or, if necessary, more than one are appointed, the selection being in the justices at the quarter-sessions. The works and the money are under the management of the surveyor, and the control is in the local magistracy. A surveyor may perform the office gratuitously, but it is the power of the parish to name and pay a salaried and professional one. The business is neglected by all; and it is doubly neglected when the commissioners are numerous, or it falls into the hands of some one who makes an interest in himself, in power or patronage, or something else, or, finally, every thing is transacted by an attorney, not always the most honorable member of his profession. As to hired surveyors, their relations with the contractors are unscrupulous; and while the wretched but cunning people who form vestries contrive to waste and squander the funds, from the spoil of which they all in turn contrive to derive a profit, there is either no efficient control, or there is no control at all. The accounts are passed under the direction of the attorney, himself dependent on the vestry, and the parish for his favor and his profits. It is unquestionable that double the money raised for these roads that would be raised under a prudent direction, free from all these interests.

Bergman quotes this general view of the subject; we shall extract from M. Dupin's grounds on the recent question, which is introduced by the following:

Table of the public roads of England, their length, and the cost of repairing them.

Public Carriage Roads in England.	Years ending in October.		
	1812.	1813.	1814.
Paved Streets and Turnpike Roads . . . . .	Miles. 19,114	Miles. 19,132½	Miles. 19,114
Other Roads . . . . .	95,105	95,142½	95,105
Total length . . . . .	114,219	114,275	114,219
Contributions in labor . . . . .	£515,508	539,522	539,522
Contributions in money . . . . .	271,512	276,947	276,947
Taxes levied for the roads . . . . .	570,754	613,604	613,604
Total . . . . .	£1,357,774	1,430,073	1,430,073
Expense of preparing documents, &c. . . . .	21,499	26,252	26,252

Thus it appears that the average annual expenses of all the roads in England were, from 1811 to 1814, as follows:—

Contributions in labor . . . . .	£535,423
Ditto in money . . . . .	278,506
Sums raised by rate . . . . .	601,954
	<u>£1,415,883</u>

This gives us £12 7s. 6d. for the average annual expense of maintaining each mile of open road. In this calculation I have deducted, says our author, 'from the total amount of the expense of road labor, the three days' labor which is allowed for turnpike roads; while six are allowed for open parish roads.

According to a report made to the house of commons on the 10th of June, 1821, the total amount of the sums levied in a single year on turnpike roads amounts to £970,618. This gives the average value of £47 18s. for the support of each mile of paved street and turnpike road. By adding the contributions in labor, the expense will amount to about £51 per mile. This revenue, immense as it is, is not sufficient for the construction of new roads, and the support of those that are already established. The different trusts have contracted debts, for which the rentals of each county are responsible. The total amount of the debts, at the period of the enquiry of which the report to which we have above alluded gives the result, was £3,874,254, that is to say, that these debts then equalled four years' revenue. It is affirmed that if the same calculation were made for Wales, Scotland, and Ireland, the general amount of the debt of the turnpike roads would amount to £7,000,000 sterling.—vol. i. p. 86.

The fact is that our modern improvements have been introduced in despite of a bad system—and, in their most decided features. The methods of Mr. M'Adam exhibit the true real genius and intelligence over all the contrivances to make bad roads—and the names, that surveyors and inspectors give to the roads.

1. Of the purposes of roads. Roads are laid down the line.—Roads are laid down the line. They have been called the veins of the country, and all its other imper-

means of them. Our legal system respecting them dates from the reign of Charles II. but it was not until the middle of the last century that scientific enquiry was directed toward them.

Before carriages of burden were generally used, little more was required than a narrow path. All marshy grounds were there cultivated, and the inequality or unevenness of the road was of much less consequence than when carriages, instead of pack-horses, were employed. When carriages were first employed, they probably were light and narrow, and did not require to have roads of any considerable breadth. And, when these had once been traced, indolence and habit prevented any great exertions to lay them out in better lines. Heavier carriages and greater traffic made wider and stronger roads necessary; the ancient track was pursued; ignorance and want of concert in the proprietors of the ground, and, above all, the want of some general effective superintending power, continued the wretched practice. At length turnpikes were established, and laws passed investing magistrates with authority to alter established lines, so that now the chief obstacle to the improvement of the lines of public roads is the expense.

In laying out roads, observes Mr. Walker, 'the most important consideration is the nature of the soil, and the direction of the wind. The soil should be such as will bear the weight of the carriage, and the wind should be such as will not blow across the road. The road should be laid out in a straight line, and the width of a lane should be such as will allow a carriage to pass off freely from the path; the opposite side of the road, to let off, into the ditch, on every side, the waters of the stream, and the side of the lane or road, and most of all, to give a sufficient



purposes, is to be calculated, by the time and exertion, jointly considered, which are required to convey a given burden, with a given power of draught, from station to station. On great public roads, where expedition is a principal object, time alone may be taken as a good criterion. A regular method of finding out the true line of road between two stations, where a blank is given, where there is no other obstruction than what the surface of the ground to be got over presents, is to ascertain, and mark at proper distances, the straight line; which is the only certain guide to the surveyor. If the straight line be found to be ineligible, each mark becomes a rallying point, in searching on either side of it for a better. If two lines of equal facility, and nearly of equal distance from the straight line, present themselves, accurate measurements are to determine the choice. If one of the two best lines which the intervening country affords is found to be easier, the other shorter, the ascent and the distance are to be jointly considered; the exertion and the time required are to be duly weighed.

That part of a road which is coated with stones is called the 'metalled' part. Although in some places, Paterson observes, it may be of little consequence, either to the traveller, or to the public in general, which way the bendings are turned, provided the level is nearly obtained,—yet a great deal may depend upon those turns or bendings for the real benefit and advantage of the road. In bending it one way, you may have no metals that will stand any fatigue, unless at a great distance and expense; while, in turning it the other way, you may have metals of the very best quality, in the immediate vicinity. In the one way, too, you may be led over ground of a wet bottom, where even, with twelve or fourteen inches deep of metals, there would be difficulty in keeping a good road; while, in the other, you may have such a dry bottom that the road would be much easier upheld with seven or eight inches of metals. So that the tract that may appear most eligible to the eye, at first sight, may not always be the one that should be adopted. 'A combination of all the requisites I have already mentioned should be studied, as far as possible; and, where these cannot be found all to unite, the one possessing the most of these advantages, and subject to no other material objection, should, of course, be adopted.' Treatise on Roads, p. 19.

Roads, Edgeworth observes, should be laid out, as nearly as may be, in a straight line; but to follow with this view the mathematical axiom, that a straight line is the shortest that can be drawn between two points, will not succeed in making the most commodious roads; hills must be avoided, towns must be resorted to, and the sudden bends of rivers must be shunned. All these circumstances must be attended to; therefore a perfectly straight road cannot often be found of any great length. It may perhaps appear surprising that there is but little difference in the length between a road that has a gentle bend, and one that is in a perfectly straight line. A road ten miles long, and perfectly straight, can scarcely be found any where,

but if such a road could be found, and if it were curved, so as to prevent the eye from seeing further than a quarter of a mile of it, in any one place, the whole road would not be lengthened more than 150 yards. It is not proposed to make serpentine roads merely for the entertainment of travellers; but it is intended to point out, that a strict adherence to a straight line is of much less consequence than is usually supposed; and that it will be frequently advantageous to deviate from the direct line, to avoid inequalities of ground. It is obvious that, where the arc described by a road going over a hill is greater than that which is described by going round it, the circuit is preferable; but it is not known to every overseer that within certain limits it will be less laborious to go round the hill, though the circuit should be much greater than that which would be made in crossing the hill. Where a hill has an ascent of no more than one foot in thirty, the thirtieth part of the whole weight of the carriage, of the load, and of the horses, must be lifted up, whilst they advance thirty feet. In doing this, one-thirtieth part of the whole load continually resists the horses' draught; and, in drawing a waggon of six tons weight, a resistance equal to the usual force of two horses must be exerted.

A perfectly level road, it has been often said is not the best for every species of draught. Slight and short alternations of rising and falling ground are serviceable to horses moving swiftly; the horses have time to rest their lungs and different muscles: and of this experienced drivers know well how to take advantage. Marshal concurs in this opinion, as well as Walker Telford, and most engineers; and Paterson considers that it would not be proper to line a road upon a perfect level, even to the length of one mile together, although it could be quite easily obtained. It is a fact, he says, well known to most people, at least every driver of loaded carriages knows by experience, that where a horse, dragging a load over a long stretch of road, quite level, will be exhausted with fatigue; the same length of a road, having here a gentle acclivity, and there a declivity, will not fatigue the animal so much. This is easily accounted for. On a road quite level the draught is always the same, without any relaxation; but, on a gentle ascent, one of his powers is called into exercise; on the descent, another of his powers is called into action, and he rests from the exercise of the former. Thus are his different muscular powers moderately exercised, one after another; and this variety has not the same tendency to fatigue.

Cutting through low hills to obtain a level is recommended by some, who, as Paterson observes, will argue 'that where the hill of ascent is not very long it is better, in that case, to cut through it in a straight line, and embank over the hollow ground on each side, than to wind along the foot of it. This, however, should only be done where the cutting is very high indeed, and an embankment absolutely necessary. Few people, except those who are well acquainted, are aware of the great expense of cutting and embanking; and, the more any one becomes acquainted with road-making, the more

it may be presumed, will he endeavour to avoid those levels on the straight line that are obtained only by cutting and embanking, and will either follow the level or the curved line round the hill; or, where this is impracticable, will ascend the hill, and go over it by various windings, avoiding always abrupt or sudden turnings.' *Treatise, &c. p. 15.*

According to Walker, Minutes of Evidence before a Committee of the House of Commons, 1819, a dry foundation and clearing the road from water are two of the main objects. 'For obtaining the first of these objects it is essential that the line for the road be taken so that the foundation can be kept dry, either by avoiding low ground, by raising the surface of the road above the level of the ground on each side of it, or by drawing off the water by means of side drains. The other object, viz. that of clearing the road of water, is best secured by selecting a course for the road which is not horizontally level, so that the surface of the road may in its longitudinal section form in some degree an inclined plane; and when this cannot be obtained, owing to the extreme flatness of the country, an artificial inclination may generally be made. When a road is so formed, every wheel track that is made, being in the line of the inclination, becomes a channel for carrying off the water, much more effectually than can be done by a curvature in the cross section or rise in the middle of the road, without the danger, or other disadvantages, which necessarily attend the rounding a road much in the middle. I consider a fall of about one inch and a half in ten feet to be a minimum in this case, if it is attainable without a great deal of extra expense.'

The ascent of hills, as observed by Marshal, is of course one of the most difficult parts of laying out roads. According to theory, he says, an inclined plane of easy ascent is proper; but as the moving power on this plane is 'neither purely mechanical, nor in a sufficient degree rational, but an irregular compound of these two qualities, the nature and habits of this power' require a varied inclined plane, or one not a uniform descent, but with levels or other proper places for rests. According to the road act the ascent or descent should not exceed the rate or proportion of one foot in height to thirty-five feet of the length thereof, if the same be practicable, without causing a great increase of distance. Mr. Telford, Minutes before the Committee of the House of Commons, &c., 1819, referring to those which he has lately made through the most difficult and precipitous districts of North Wales, says, 'the longitudinal inclinations are in general less than one in thirty; in one instance for a considerable distance there was no avoiding one in twenty-two, and in another, for about 200 yards, one in seventeen; but, in these two cases, the surface of the road-way being made peculiarly smooth and hard, no inconvenience is experienced by wheeled carriages. On flat ground the breadth of the road-way is thirty-two feet; where there is side cutting not exceeding three feet, the breadth is twenty-eight; and, along any steep ground and precipices, it is twenty-two, all

clear within the fences; the sides are protected by stone walls, breast and retaining walls, and parapets; great pains have been bestowed on the cross drains, also the draining the ground, and likewise in constructing firm and substantial foundations for the metalled part of the road-way.'

In order to preserve a moderate inclination, or such a one as will admit of the descent of carriages without locking their wheels, a much longer line will generally be required than the arc of a hill. In reaching the summit, or highest part to be passed over, the line in many cases must be extended by winding or zig-zagging it, so as never to exceed the maximum degree of steepness. Two inches in six feet is the slope of the celebrated Simplon road. If this were extended in a straight line, on each side, it would require an enormous mound, and an immense expense; but by being conducted in a winding direction, up the hill on one side, and down the other, the same end is gained at a moderate cost. Such works show the wonderful power and ingenuity of man.

In laying out a road towards a river, or any place requiring a bridge or embankment, an obvious advantage results from approaching them at right angles; and the same will apply in regard to any part requiring tunnelling or crossing by an aqueduct, &c.: all crossings and intersections should indeed be made at right angles.

2. *Of the width and form of roads.*—It is contended, by the author of the Landed Property of England, that the plan of all public roads should admit of their being divided into three travelling lines, namely: 1. A middle road of hard materials for carriages and horses in winter and wet seasons: 2. A soft road, formed with the natural materials of the site, to be used in dry weather, to save the unnecessary wear of the hard road, and to favor the feet of travelling animals; as well as for the safety, ease, and pleasantness of travelling in the summer season: and 3. A commodious path, for the use of foot passengers, at all seasons. But in these cases, he thinks, modern practice has simplified too much. Instead of these three requisites of a public road, we generally find a parliamentary or turnpike road (away from the environs of great towns) consisting simply of one uniform roadway of hard materials; upon which horses stumble, and carriages jolt, the year round: while travellers on foot are seen wading to their ankles in mud, or in dust, according to the state of the wind and weather. His notions of what the nature of a public road ought to be is, that within the fences of a lane or road there should be a raised foot-path, a convex hard road, a soft summer road, and channels to carry off the water collected by the carriage roads; the foot-path being cut across in proper places, to permit the water, which falls on that side of the middle road, to pass off freely into the ditch at that side, as well as to prevent horsemen from riding along the path; the opposite hedge-bank being perforated, to let off, into the other drain on the contrary side, the waters which may collect on that side of the lane or road. Mr. Telford, Mr. Walker, and most other engineers, consider seventy feet a sufficient

width for roads near the largest towns and cities, and that ten or twenty feet of this may in some cases be paved. The London Commercial Road, constructed by the last-named engineer, is of this width and character, and there are fifteen feet of gravel road at each side for light carriages or horses. It has been executed for sixteen years, and has given the greatest satisfaction; but Mr. Walker thinks that considerable improvement would be found from paving the sides of a road, upon which the heavy traffic is great, in both directions, and leaving the middle for light carriages; the carmen or drivers, walking upon the foot-paths or sides of the road, would then be close to their horses, without interrupting or being in danger of accidents from light carriages, which is the case when they are driving upon the middle of the road; and the unpaved part, being in the middle or highest part of the road, would be more easily kept in good repair. But unless the heavy traffic in both directions is great, one width, say ten or twelve feet, in the middle of the road, well paved, will be found sufficient for all ordinary wear. The width of many of the present roads is, besides, such, that ten or twelve feet can be spared for paving, while twice that width would leave too little for the gravelled part. Although the first cost of paving is great he does not think that any other plan can be adopted so good and so cheap in those places where the materials got in the neighbourhood are not sufficient for supporting the roads. A coating of whinstone is, for instance, more durable than the gravel with which the roads round London are made and repaired; but much less so than paving; although the freight and carriage of the whinstone, and of the paving-stones, which form the principal items of the expense, are nearly the same.

Proportioning the breadth of roads to the traffic for which they may be employed, has, perhaps, not been sufficiently attended to. In remote places, where there is but little traffic, the waste of ground occasioned by superfluous width of roads, is an error: there being many places where roads of twenty feet breadth would suit the public convenience, as well as if they were twice as broad; and it is clear that, if a road is one pole or perch wider than is necessary, there is a waste of 320 perches in a mile, equal to two acres of ground, which, at the rate of £3 per acre, would, if the road had been once well made, keep half a mile of such road as is here alluded to in good repair. According to Paterson, the breadth of the road and the width of the metals, or paved part, should depend on circumstances different from the former. For a few miles in the vicinity of such cities as London or Edinburgh, the most proper breadth at which a road should be formed, he thinks, is from sixty to seventy feet, and the metals from twenty-five to thirty-five feet; while, in the neighbourhood of such towns as Newcastle and Perth, it will be sufficient that it be formed forty feet broad, and that the width of the metals be about eighteen or twenty feet. These are the breadths presumed to be the most eligible in such situations. But rules cannot be given to suit every situation: the breadth ought to be regulated according to the

extent of the run of commerce, or traffic, upon the road. As a general rule however, for public roads over the different counties of Great Britain, I should suppose, he says, the following might in most cases be adopted. Take for instance the road betwixt Edinburgh and Glasgow, or betwixt Edinburgh and Aberdeen, by the way of Dundee. These roads are formed in general from thirty-five to forty feet wide; and the breadth of the metals is from fourteen to sixteen feet for the most part. Such roads as these would be found to answer very well, in general, over the kingdom. A breadth sufficient for the general purposes of country travelling, according to M'Adam, is sixteen feet of solid materials, with six feet on each side formed of slighter materials. The Bristol roads, he says, are made with stone about the width of sixteen feet.

Narrow roads, it is well observed by Fry, are almost always in bad condition, which is to be accounted for from the circumstance of every carriage being obliged to go in the same ruts; and, as each rut is generally only six inches wide, one foot of the road only is worn by the wheels instead of the whole breadth of it; which would be the case if the road were of a proper width, and if it were well constructed. If a road be laid out from twenty to thirty feet wide, so flat as that a carriage may stand nearly upright on every part of it, and if moderate care be taken by the surveyor to prevent the first formation of ruts, such a road will be worn by the wheels nearly alike on every part of it: provided also that the ground on each side, for at least four or five feet, be moderately flat, so as not to excite fear in the drivers of carriages; but if there be deep ditches close to the sides of the road, or if the circumjacent land fall off very abruptly to the depth of two or three feet, whereby fear of approaching the edges would operate on the minds of the drivers, every driver will instinctively avoid the danger on either hand; and a road so circumstanced will, in spite of any care of the surveyor, inevitably be worn into ruts in the middle. There is a remarkable instance of this kind in a piece of road on Durdham Down, near Bristol. This road is a causeway over a piece of soft ground; and, although it is from twenty to twenty-five feet wide, yet, as the ground falls away abruptly on both sides of it, it has been found impossible, for more than twenty years past, to his knowledge, to prevent deep ruts being formed along the middle of it; notwithstanding the Down itself consists of hard limestone; and the other roads upon the Down are as fine and even as any roads in England. Were this piece of road widened out on each side, in an easy slope about five feet, by rubbish of any kind, and by the scrapings of the road itself, whereby the insunctive operation of fear of approaching the sides of the present road would be obviated, that piece of road would be found to wear as fairly as the other roads on the same Down.

When roads run through marshy ground, observes Mr. Edgeworth, 'the substratum must be laid dry by proper drainage; and where the road is liable, from the flatness of the country, to be at times under water, the expense of raising it above the water must be submitted to in the

first instance. All drains for carrying off water should be under the road, or at the field side of the fences, and these drains should be kept open by constant attention, and should be made wide at the outlet.' Telford and Walker recommend the side drains to be in every instance on the field side of the fence. In cases, Telford observes, where a road is made upon ground where there are many springs, it is absolutely necessary to make a number of under and cross drains to collect the water and conduct it into the side drains, which should always be made on the field side of the fences. The orifices of these cross drains should be neatly and substantially finished in masonry. 'Before the materials are put on, run a drain along the middle of the road, all the way, from two to three feet deep; then fill it with stones up to the surface, making those at bottom of a pretty good size, and those at the top full as small as the road materials. And, in order that the quantity of stones used for the said drain may be as little as possible, and every way to save expense, it may be made as narrow as it can possibly be dug. From this leading drain make a branch here and there to convey off the water to the canals on the sides of the road.'—Paterson. This mode of draining he has found from experience to be so beneficial that a road so drained would be better and more durable with eight inches, than it would otherwise be with twelve inches of materials. And not only so, but that on such a road there would be a saving on the incidental repairs, ever afterwards, of about one-half of the labor, and at least one-third of the material. 'All moisture from under the road materials should be carried off by such drains. Where such drains are wanting, the road, on the return of a thaw, throws up to the surface all the water it had imbibed; and in many places the materials, swelling up, become quite loose and open. This is a natural consequence, where the material is not thick, and where the soil under the road is not perfectly dry. But, where a road is dried in the way described, it will be uniformly seen that the water, instead of spewing out on the return of a thaw, is sucked in by the drains, so leaving the surface of the road quite dry. It may be observed, at such times, that the places of the road where a few rods of such drain had been introduced, presented to the eye, at a quarter of a mile distance, quite a contrast to the other parts of the road; the one opaque and dry, from the moisture being sucked in, the other all wet and glistening, from its being thrown out to the surface.'—*Paterson's Letters, &c.*, 44, 48, 84.

Embankments and bridges of different degrees of magnitude, are required in most lines of road. Large bridges we must leave to engineers; no department of their art having attained higher perfection. We here confine ourselves entirely to such stone arches as may be designed by road-surveyors, and built by country masons. In many cases cast-iron might be substituted for stone with economy and advantage as to water-way; but, though the principle of constructing both cast and wrought iron bridges is perfectly simple, the execution, and especially the putting up, requires more skill, and is attended with

much more risk than the erection of other bridges.

One low arch is thought by Mr. Loudon to be in general the most desirable description of common road-bridges. But most of the country bridges, as Clarke observes, consist of several small, high, semicircular arches: where there is a single arch, the stream passes without interruption; if there are two or three in the same situation, the space through which the water is to pass is necessarily contracted by the width of piers. Ice, and large bodies carried down by the floods, frequently stop up the small arches, and the accumulated water carries away the bridge; but, if such accidents should not happen, the constant currents rushing against those piers wash out the mortar, loosen the stones, and very soon undermine the work if it is not extremely well put together, which is seldom the case. Unless the river or stream is narrow, or the banks very high, a semicircle is an inconvenient shape for an arch; it has been adopted on account of the insufficiency of the abutments, and because the pressure is more perpendicular; but scientific engineers, in all countries, now construct their bridges with wide openings, and make the arches either semi-ellipses, or segments of large circles; so that the space above the highest floods is comparatively little, and the ascent over the bridge inconsiderable. In country bridges in Ireland, Clarke continues, the foundations are invariably, and often intentionally, defective: the mason considers himself an honest man if his bridge lasts seven years; whereas, from the durability of materials in that country, it ought to endure for ages. Whatever is under water is out of sight, and is generally composed of loose stones, thrown promiscuously together, on which the masonry is erected, and all the pains and expense are bestowed on the cutwaters and wings, when the heaviest stones, and those accurately jointed, ought to be laid in the foundations. The greatest attention should be paid to the quality of the materials: the stones should be large, and laid in level courses, in the best mortar, composed of sharp sand, free from loam, and quicklime, accurately mixed together; the coping of the parapet is generally so slight that it is broken down as soon as built, and the entire parapet quickly follows; it ought to be of large heavy stones, roughly hammered, and there should be substantial quoins at the ends of the parapets with an immovable stone over them. Arches not exceeding eight feet span may be semicircular; tunnels not exceeding eighteen inches wide may be covered with strong flags, and either flagged or paved under, and there ought to be across either end a deep long stone, sunk below the surface of the current, and under the walls, to prevent the water from undermining the work.

Fences along the sides of roads are essential in all enclosed countries; and all engineers and road-makers agree that they should never be allowed to rise to a greater height than what is necessary for a fence. To give free admission to the sun and air, by keeping the fences low, Marshall considers as providing an expensive, yet most accurate method of cleaning roads, incomparably more so than washing or scraping. The

legislature, Edgeworth observes, has limited, in several instances, the height of hedges to five feet; but this limitation is neglected or evaded. Even were it strictly adhered to, it would not be sufficient for narrow roads; the hedges would be still too high, for it is the sweeping power of the wind which carries off dust in dry weather, and which takes up moisture in wet. In fact, roads become dry by evaporation; and, when they are exposed to the sun and wind, the effect of heat and ventilation are more powerful than any surface drainage that could be accomplished. Walker observes that the advantage of having the hedge next the road consists in its greater safety to the traveller, particularly if a ditch of any considerable depth is necessary, and in the hedge being supported in its growth from the ground under the road, without drawing upon the farmer's side of the ditch. The fences, Telford observes, form a very material and important subject, with regard to the perfection of roads; they should in no instance be more than five feet in height above the centre of the road, and all trees which stand within twenty yards from the centre of it ought to be removed. I am sure that twenty per cent. of the expense of improving and repairing roads is incurred by the improper state of the fences and trees along the sides of it, on the sunny side more particularly; this must be evident to any person who will notice the state of a road which is much shaded by high fences and trees, compared to the other parts of the road which are exposed to the sun and air. My observations, with regard to fences and trees, apply when the road is on the same level as the adjacent fields; but in many cases, on the most frequented roads of England, more stuff has been removed from time to time than was put on; the surface of the road is consequently sunk into a trough or channel from three to six feet below the surface of the fields on each side; here all attempts at drainage, or even common repairs, seem to be quite out of the question; and by far the most judicious and economical mode will be to remove the whole road into the field which is on the sunny side of it.—*Examination before the House of Commons, &c.*

3. *Of the foundation of roads.*—Edgeworth, Marshall, and all the practical engineers before Mr. M'Adam differ with him as to the base of roads. The author of Landed Property in England would prepare the ground by striking off the protuberances, and filling up the hollow parts: the footpath and the higher side of the soft road being raised with the earth which is required to be taken off the bed of the hard road; whose base or foundation ought to be formed with peculiar care. Every part is required, as he says, to be firm and sound: dry earth, or hard materials, being rammed into every hollow and yielding part. In a dry situation, as across a gravelly or stony height, little more, he says, is required than to remove the surface mould, and lay bare the rock, or bed of gravel beneath it: and, then, to give the indurate base a rounded or a shelving form, as the lying of the ground may require. In this way, a travelable road may be made, and kept up, at one-tenth of the expense incurred by the ordinary practice in this case;

which is to gather up the surface-soil into a ridge, and, on this soft spongy bed, to lay, coat after coat, some hard materials,—fetched perhaps from a distance. But M'Adam contends that a stratum of hard materials covering a morass will last longer than a similar stratum laid on rock; indeed, according to this able engineer, it may be questioned whether a properly made road on a bog, which yields by its elasticity, will not last longer than one on a firm surface. In Ireland this is said to be found actually the case: 'For the same cause,' as Fry observes, 'that a stone placed upon a wool-pack would bear a greater pressure before it would be broken, than it would if placed on an anvil.'—*Essay on Wheel Carriages, &c.* Edgeworth and many others have recommended covering the base of an unsound road with faggots, branches, furze, or heath. Flat stones, he adds, if they can be had, should then be laid over the faggots, and upon them stones of six or seven pounds' weight, and, lastly, a coat of eight or ten inches of pounded stone. If the practicability of consolidating a mass of stones of six or eight ounces weight and under each, so as to act as one plate or flooring, be admitted, then the faggots and flat stones must at least be useless, and the stones of six or seven pounds' weight injurious; because, whenever the upper stratum has worn down a few inches, some of these stones, and eventually the greater number will be worked up to the surface, and the road destroyed or put in a state to require lifting, breaking, and relaying. A basement of trees, bawns, or bushes, was made use of by Walker when the ground was soft. They carry off the water previous to the materials of the road being so consolidated as to form a solid body, and to be impervious to water. Bushes are, however, not advisable to be used, unless they are so low as always to be completely moist. When they are dry and excluded from the air they decay in a few years, and produce a sinking in the road; a thickness of chalk is useful for the same purpose in cases where bushes are improper: the chalk mixing with the gravel or stones becomes concreted, and presents a larger surface to the pressure.

Mr. M'Adam would lay his 'metals' at once on the earth, provided it were even a bog, 'if a man could walk over it.' In his examination before the house of commons he says, 'the Somersetshire morass is so extremely soft that when you ride in a carriage along the road you see the water tremble in the ditches on each side; and the vibration so great that it will break you in.' Yet here he would use no large foundation stones, 'nor faggots, nor any material larger than will weigh six ounces. If a road be made smooth and solid, it will be one mass, and the effect of the substrata, whether clay or sand, can never be felt in effect by carriages going over the road; because a road well made unites itself in a body like a piece of timber or a board.' And we may now introduce

4. *Mr. M'Adam's system.*—This able and ingenious engineer agrees with many of his predecessors that a good road may be considered as an artificial flooring, forming a strong, solid, smooth-surfaced stratum, sufficiently flat to

admit of carriages standing upright on any part of it, capable of carrying a great weight, and presenting no impediment to the animals or machines which pass along it. In forming this flooring, he has, however, gone one material step beyond his predecessors in breaking the stone to a smaller size, and in forming the entire stratum of this small-sized stone. It is in this point, of making use of one small size of stones throughout the stratum, that the originality of Mr. M'Adam's plan consists. It is doubted by some whether this would be durable in the northern districts at the breaking up of frosts, and especially in the case of roads not much in use, or consisting of a stratum less consolidated, and more penetrable by water. 'The durability of roads,' he says, 'will of course depend on the strength of the materials of which they may be composed, but they will all be good while they last, and the only question that can arise respecting the kind of materials is one of duration and expense, but never of the immediate condition of the roads.'—Remarks on Roads, &c. p. 11.

Roads can never be rendered perfectly secure, according to this gentleman (see his report to the board of agriculture), until the following principles be fully understood, admitted, and acted upon: namely, that it is the native soil which really supports the weight of traffic; that while it is preserved in a dry state it will carry any weight without sinking; and that it does, in fact, carry the road and the carriages also; that this native soil must previously be made quite dry, and a covering impenetrable to rain must then be placed over it to preserve it in that dry state; that the thickness of a road should only be regulated by the quantity of materials necessary to form such impervious covering, and never by any reference to its own power of carrying weight. The erroneous opinion, so long acted upon, that by placing a large quantity of stone under the roads, a remedy will be found for the sinking into wet clay, or other soft soils; or, in other words, that a road may be made sufficiently strong, artificially, to carry heavy carriages, though the sub-soil be in a wet state, and by such means to avert the inconveniences of the natural soil receiving water from rain, or other causes, seems to have produced most of the defects of the roads of Great Britain. At one time Mr. M'Adam had formed the opinion that this practice was only a useless expense; but experience has convinced him that it is likewise positively injurious.

In confirmation of this, if strata of stone of various sizes be placed as a road, it is well known to every observant road-maker that the largest stones will constantly work up by the shaking and pressure of the traffic; and that the only mode of keeping the stones of a road from motion is to use materials of a uniform size from the bottom. In roads made upon large stones, as a foundation, the perpetual motion, or change of the position of the materials, keeps open many apertures, through which the water passes. It has also been found that roads placed upon a hard bottom wear away more quickly than those which are placed upon a soft soil. This has been apparent upon roads where motives of eco-

nomy, or other causes, have prevented the road being lifted to the bottom at once; the wear has always been found to diminish, as soon as it was possible to remove the hard foundation. As to the fact, already adverted to, that a road lasts much longer over a morass than when made over rock, the evidence produced before the committee of the house of commons showed the comparison, on the road between Bristol and Bridgewater, to be as five to seven in favor of the wearing on the morass, where the road is laid on the naked surface of the soil, against a part of the same road made over rocky ground.

Water, with alternate frost and thaw, are the great evils to be guarded against in the base of a road: consequently nothing can be more erroneous than providing a reservoir for water under the road, and giving facility to the water to pass through the road into this trench, where it is acted upon by frost to the destruction of the road. As no artificial road can ever be made so good and so useful as the natural soil in a dry state, it is only necessary to procure and preserve, according to M'Adam, this dry state of so much ground as is intended to be occupied by a road. The first operation is to be the reverse of digging a trench. The road should not be sunk below, but rather raised above the ordinary level of the adjacent ground; care should at any rate be taken that there be a sufficient fall to take off the water, so that it should always be some inches below the level of the ground upon which the road is intended to be placed: this must be done, either by making drains to lower ground, or if that be not practicable, from the nature of the country, then the soil upon which the road is proposed to be laid must be raised by addition, so as to be some inches above the level of the water.

Having secured his soil from under-water, the road-maker is next to secure it from rain by a solid road made of clean dry stone or flint, so selected, prepared, and laid, as to be perfectly impervious to water; and this cannot be effected unless the greatest care be taken that no earth, clay, chalk, or other matter, that will hold or conduct water, be mixed with the broken stone; which must be so prepared and laid as to unite with its own angles into a firm, compact, impenetrable body. The thickness of this body is immaterial, as to its strength for carrying weight; this object is already obtained by providing a dry surface, over which the road is to be placed as a covering or roof, to preserve it in that state: experience having shown that if water passes through a road, and fill the native soil, the road, whatever may be its thickness, loses its support, and goes to pieces. In consequence of an alteration in the line of the turnpike-road, near Rownham-ferry, in the parish of Aslton, near Bristol, it was necessary to remove the old road. This road was lifted, and re-laid very skilfully in 1806; since which time it has been in contemplation to change the line, and consequently it has been suffered to wear very thin. At present it is not above three inches thick in most places, and in none more than four: yet, on removing the road, it was found that no water had penetrated, nor had the frost affected it during

the winter preceding, and the natural earth beneath the road was found perfectly dry. Various new roads have been constructed on this principle within the last few years; the great north road from London, by Hoddesdon, in Hertfordshire; two pieces of road on Durdham Down, and at Rownham-ferry, near Bristol; with several private roads in the eastern parts of Sussex, are amongst the best specimens. None of these roads exceed six inches in thickness; and, although that on the great north road is subjected to a heavy traffic, it has not given way, nor was it affected by the severe winters it has experienced, and when other roads between that and London became impassable, by breaking up to the bottom, and the mail and other coaches were obliged to reach London by other routes. Improvement of roads, says M.A. (in 1824), upon the principle I have endeavoured to explain, has been rapidly extended during the last four years. It has been carried into effect on various roads, and with every variety of material, in seventeen different counties. These roads being so constructed as to exclude water, consequently none of them broke up during the late severe winter (1819-20); there was no interruption to travelling, nor any additional expense by the post-office in conveying the mails over them, to the extent of upwards of 1000 miles of road.

We may add that several large streets and thoroughfares of the metropolis have been unpaved, and laid down again on the principles of Mr. M'Adam. The result has not been uniformly successful; but in the cases where the paving system has been renewed, we believe the base has been M'Adamised, and so a substantial improvement has, on the whole, been obtained.

ROAM, *v. n. & v. a.* } Ital. *romigare*; Goth. ROAM'ER, *n. s.* } *ruma*. See ROOM. To wander without any certain purpose; to ramble; to rove; to play the vagrant. 'Imagined to come from the pretences of vagrants, who said they were going to Rome.'

Five summers have I spent in farthest Greece,  
Roaming clean through the bounds of Asia.

Shakespeare.

Now fowls in their clay nests were couched,  
And now wild beasts came forth the woods to roam.

Milton.

The lonely fox roams far abroad,  
On secret rapine bent, and midnight fraud.

Prior.

What were unenlightened man,  
A savage roaming through the woods and wilds  
In quest of prey.

Thomson's Summer.

ROAN, *adj.* Sax. noon; Fr. *rouen*; Ital. *roano*; Span. *ruano*. Of a bay sorrel or sorrel gray color.

Roan horse is a horse of a bay, sorrel, or black colour, with grey or white spots interspersed very thick.

Farrier's Dictionary.

ROANNE, a considerable trading town of France, on the left bank of the Loire, where that river is only forty miles north-west of Lyons. In the beginning of the last century it was a mere village; and it owes its increase to its having become an entrepot for goods sent from the east and south-east of France, to Orleans, Nantes, Paris, &c. It has now 7000 inhabitants. The streets stretch out in various directions into the country, and the most remote parts of them are intermixed with trees. In the interior, however,

it has tolerably straight streets, and good houses; and manufactures of linen, cotton, small iron wares, &c.

ROANOKE, a river of North Carolina, formed by the union of the Staunton and the Dan, the former of which rises in Virginia, and the latter in North Carolina, and flows into Albemarle Sound, long. 76° 56' W., lat. 35° 58' N. It is navigable for vessels of considerable burden thirty or forty miles, and for boats of thirty or forty tons to the falls, seventy miles; and for boats of five tons for the distance of 200 miles above the falls. The country watered by this river is extremely fertile. Below the falls vast quantities of Indian corn are raised; and the planters are among the wealthiest in the state. Exertions are making to improve the navigation of this river by constructing canals around the falls: opening a water communication between Norfolk, Valentia, and the interior of North Carolina, and the southern part of Virginia.

ROAR, *v. n. & n. s.* } Saxon *rapan*; Goth. ROAR'ER, *n. s.* } *runtir*. To cry as a lion or wild beast; bellow; cry in distress; make a loud noise: the cry or noise made: a roarer is a noisy man.

The young lions roared upon him, and yelled.  
Jeremiah ii. 15.

Roaring bulls he would make him to tame.  
Spenser.

Warwick and Montague,  
That in their chains fettered the kingly lion,  
And made the forest tremble when they roared.  
Shakespeare.

At his nurse's tears,  
He whined and roared away your victory,  
That pages blushed at him. *Id.* *Coriolanus*.  
Where be your gibes now? your gambols? your songs? your flashes of merriment, that were wont to set the table in a roar? *Id.* *Hamlet*.

The English roarers put down all. *Howel*.  
Deep throated engines belched, whose roar  
Imbowed with outrageous noise the air. *Milton*.

Oft on a plat of rising ground,  
I hear the far-off curfew sound,  
Over some wide-watered shoar,  
Swinging slow with sullen roar. *Id.*

When cannons did diffuse,  
Preventing posts, the terror, and the news;  
Our neighbour princes trembled at their roar. *Waller*.

The death of Daphnis woods and hills deplore,  
They cast the sound to Libya's desert shore;  
The Libyan lions hear, and hearing roar. *Dryden*.

Sole on the barren sands the suffering chief  
Roared out for anguish, and indulged his grief. *Id.*  
The waters, listening to the trumpet's roar,  
Obey the summons, and forsake the shore. *Id.*

The roar  
Of loud Euroclydon. *Philips*.

Consider what fatigues I've known,  
How oft I crossed where carts and coaches roared. *Gay*.

Loud as the wolves on Orcas' stormy steep,  
Howl to the roaring of the northern deep. *Pope*.

The wonted roar is up,  
And hiss continual through the tedious night. *Thomson*.

Earth shakes beneath them, and Heaven roars  
above;  
But nothing scares them from the course they love. *Cowper*.

ROARY, *adj.* Better, rory; *Lat. rores.* Dewy.

On Lebanon his foot he set,  
And shook his wings with roary May dews wet.

*Fairfar.*

ROAST, *v. a. & part. adj.* Saxon *zerortōð*, roasted; *Fr. rostir, rotir*; *Teut. rosten*, from *Lat. rastrum*, a grate. To dress meat before the fire: originally, to broil it: to heat; vex; tease: to rule the roast' is, to preside; manage.

Where champions ruleth the roast,  
Their daily disorder is most. *Tusser's Husbandry.*

*Roasted* in wrath and fire,

He thus o'ersized with coagulate gore,

Old Priam seeks. *Shakespeare.*

The new made duke that rules the roast. *Id.*

In eggs boiled and roasted there is scarce difference to be discerned. *Bacon's Natural History.*

He lost his roast beef stomach, not being able to touch a sirloin. *Addison.*

And, if Dan Congreve judges right,

Roast beef and ale make Britons fight. *Prior.*

Alma slap-dash is all again

In every sinew, nerve, and vein;

Runs here and there, like Hamlet's ghost,

While every where she rules the roast. *Id.*

Roasting and boiling are below the dignity of your office. *Swijt's Directions to the Cook.*

Here elements have lost their uses,

Air ripens not, nor earth produces;

Fire will not roast, nor water boil. *Swift.*

ROASTING, in metallurgy, the dissipation of the volatile parts of ores by heat. See METALLURGY.

ROB, *n. s.* Sax. *rope*; *Port. roob.* Inspisated juices.

The infusion, being evaporated to a thicker consistence, passeth into a jelly, *rob*, extract, which contain all the virtues of the infusion.

*Arbuthnot on Aliments.*

ROB, *v. a.* } Old Fr. *robber*; *Ital. rob-*  
ROBBER, *n. s.* } *bare*; *Teut. rauber.* To de-  
ROB'ING. } prive of any thing by unlawful violence; to thief; plunder; take away: hence set free: the noun-substantives corresponding.

Thieves for their robbery have authority,  
When judges steal themselves. *Shakespeare.*

Is't not enough to break into my garden,

And, like a thief, to come to rob my grounds,

But thou wilt brave me with these sawcy terms? *Id.*

Our house is hell, and thou, a merry devil,  
Didst rob it of some taste of tediousness. *Id.*

Better be disdained of all, than fashion a carriage to rob love from any. *Id.*

These hairs, which thou dost ravish from my chin,  
Will quicken and accuse thee: I'm your host;

With robbers' hands, my hospitable favours

You should not ruffle thus. *Id.*

Procure, that the nourishment may not be robbed and drawn away. *Bacon's Natural History.*

Our sins being ripe, there was no preventing of God's justice from reaping that glory in our calamities, which we robbed him of in our prosperity. *King Charles.*

Had'st thou not committed

Notorious murder on those thirty men

At Ascalon;

Then, like a robber, strip'd'st them of their robes. *Milton's Agonistes.*

Some more effectual way might be found, for suppressing common thefts and robberies. *Temple.*

I have not here designed to rob him of any part of that commendation which he has so justly acquired

VOL. XVIII.

from the whole author, whose fragments only fall to my portion. *Dryden.*

Bold Prometheus did aspire,  
And stole from heaven the seeds of fire;

A train of ills, a ghastly crew,

The robber's blazing track pursue. *Id. Horace.*

Public robbers are more criminal than petty and common thieves. *Davenant.*

The robber must run, ride, and use all the desperate ways of escape; and probably, after all, his sin betrays him to the gaol, and from thence advances him to the gibbet. *South.*

The water-nymphs lament their empty urns,

Boeotia, robbed of silver Dirce, mourns. *Addison.*

Rob, in pharmacy, is the juice of fruits purified and inspissated till it is of the consistence of honey.

ROBBERY, the rapina of the civilians, is the felonious and forcible taking from the person of another of goods or money to any value, by violence, or putting him in fear. 1. There must be a taking, otherwise it is no robbery. A mere attempt to rob was indeed held a felony, so late as Henry IV.'s time; but afterwards it was taken to be only a misdemeanor, and punishable with fine and imprisonment; till the statute of 7 Geo. II. c. 21, which makes it a felony (transportable for seven years), unlawfully and maliciously to assault another, with any offensive weapon or instrument; or by menaces, or by other forcible or violent manner, to demand any money or goods, with a felonious intent to rob. If the thief, having once taken a purse, returns it, still it is a robbery; and so it is, whether the taking be strictly from the person of another, or in his presence only: as where a robber, by menaces and violence, puts a man in fear, and drives away his sheep or his cattle before his face. It is immaterial of what value the thing taken is: a penny, as well as a pound, thus forcibly extorted, makes a robbery. Lastly, the taking must be by force, or a previous putting in fear; which makes the violation of the person more atrocious than privately stealing. This species of larceny is debarred of the benefit of clergy, by statute 23 Hen. VIII. c. 1., and other subsequent statutes; not indeed in general, but only when committed in a dwelling-house, or in or near the king's highway. A robbery, therefore, in a distant field, or footpath, was not punished with death, but was open to the benefit of clergy, till the statute of 3 and 4 W. & M., c. 9. which takes away clergy from both principals and accessories before the fact, in robbery, wheresoever committed.

If a man force another to part with his property, for the sake of preserving his character from the imputation of having been guilty of an unnatural crime, it will amount to a robbery, even though the party was under no apprehension of personal danger. If any thing is snatched suddenly from the head, hand, or person of any one, without any struggle on the part of the owner, or without any evidence of force or violence being exerted by the thief, it does not amount to robbery. But if any thing be broken or torn in consequence of the sudden seizure, it would be evidence of such force as would constitute a robbery: as where a part of a lady's hair was torn away by snatching a diamond pig

2 S



from her head, and an ear was torn by pulling off an ear-ring; each of these cases was determined to be a robbery. The hundred in which a robbery is committed is liable to pay the damage when it is committed between the rising and setting of the sun, on any day except Sunday, in case the robbers are not taken in forty days; hue and cry being made after the robber. The property taken must be of some value. Therefore, in a case where the prisoner had obtained a note of hand from a gentleman, by threatening with a knife, held to his throat, to take away his life, and it appeared that she had furnished the paper and ink with which it was written, and that the paper was never out of her possession, this was holden not to be a robbery; the judges being of opinion that the note was of no value to the prosecutor, and not within the proviso of statute 2 Geo. II. c. 5. sect. 3: making the stealing a chose in action felony.

**ROBE**, *n. s.* & *v. a.* Fr. *robe*; Ital. *robba*; low Lat. *raubia*; Span. *ropa*, quod à Gr. *ρωρος*, i. e. mercy.—Minsheu. A gown of state; a dress: to invest with robes.

Through tatter'd cloaths small vices do appear;  
Robes and furred gowns hide all. *Shakspeare.*

What Christian soldier will not be touched with a religious emulation, to see an order of Jews do such service for enlarging the christian borders; and an order of St. George only to robe and feast, and perform rites and observances? *Bacon.*

The last good king, whom willing Rome obey'd  
Was the poor offspring of a captive maid;  
Yet he those robes of empire justly wore,  
Which Romulus, our sacred founder, wore. *Dryden.*

There in long robes the royal magi stand;  
The sage Chaldeans rob'd in white appeared,  
And Brachmans. *Pope's Temple of Fame.*  
Robed in loose array she came to bathe. *Thomson.*

**ROBERT I. or ROBERT BRUCE.** See **BRUCE** and **SCOTLAND.**

**ROBERT of GLOUCESTER**, the oldest of the English poets. He flourished in the reign of Henry II. Camden quotes many of his old English rhymes, and speaks highly in his praise. He died in the beginning of king John's reign, at an advanced age.

**ROBERTS** (Rev. Peter), M. A., a Welsh divine, and writer on British history, was a native of North Wales, and received his education at Trinity College, Dublin. Having taken orders, he obtained the living of Halkin, in the county of Flint. He published, Letters to M. Volney, in answer to his book on the Revolution of Empires, 8vo.; A Harmony of the Epistles, 4to.; A Sketch of the Early History of the Ancient Britons, 8vo.; and A Review of the Policy and Peculiar Doctrines of the Modern Church of Rome, 1809, 8vo. But his best work is The Chronicle of the Kings of Britain, 1810, 4to, a translation from the ancient Welsh Chronicles, with copious notes and illustrations. His death took place in 1819.

**ROBERTS' ISLANDS**, two large islands of the Pacific, discovered by Henguiust, in 1792. The largest has no convenient landing place, and seems only to be inhabited by tropical oceanic birds. The north-west side of the island has a more favorable aspect; and, although its shores are rocky, a number of trees are produced.

There are also some coves and bays, which afford good anchorage and shelter. Long. 219° 47' E., lat. 7° 5' S.

**ROBERTELLS** (Francis), a learned Italian, of the sixteenth century, who was successively professor of philosophy and rhetoric at Lucca, Pisa, Bologna, and Padua. He wrote commentaries on several of the Greek and Latin poets, and several other works. He died in 1567.

**ROBERTSON** (William), D. D., a learned divine, born in Dublin, in 1705. He took the degree of M. A. at Glasgow, whence he returned to Ireland, and, entering into orders, obtained several considerable livings. All these, however, he resigned in 1764; and, in 1766, published his apology, with reasons for what he had done. He presented a copy of his work to the University of Glasgow, upon which the professors gave him the degree of D. D. The company of merchant tailors, patrons of the grammar-school of Wolverhampton, presented him with the mastership of it, in which office he died in 1783.

**ROBERTSON** (William), D. D. and F. R. S. of Edinburgh, a late celebrated historian and clergyman of the church of Scotland, born in Edinburgh in 1721. He was educated at the school of Dalkeith, and afterwards at the University of Edinburgh. In 1743 he was appointed minister of Gladsmuir. On the death of his parents he took his sisters and a younger brother, afterwards a respectable jeweller in Edinburgh, under his care, though his living did not then exceed £100 a-year, and maintained them till they were all settled in the world. In 1751 he married the daughter of the Rev. Mr. Nisbet, one of the ministers of Edinburgh. About this period he began to attain eminence as an orator, and not long after became a leading member in the General Assembly. In 1755 he preached a sermon before the Society for Propagating Christian Knowledge, on the state of the world previous to the appearance of Christ, the only one he ever published, and which was much admired. In February, 1759, he published his celebrated History of Scotland, in 4to., which was received with unbounded applause. While this work was in the press, he was translated from Gladsmuir to Edinburgh. In 1759 he was appointed chaplain of Stirling Castle; in 1761 one of his majesty's chaplains; and in 1762 principal of the University of Edinburgh. In 1764 the office of king's historiographer for Scotland was revived in his favor, with a salary of £200 a-year. About 1761 he began, and in 1769 published his celebrated History of Charles V. in 4to. In 1775 the Dr. published his History of America, which excellent work he received £4500. In 1780, after having for nearly thirty years acted the most conspicuous part in the supreme ecclesiastical court, he retired from the General Assembly. In 1790 he published his Historical Disquisition concerning ancient India. He died at Edinburgh, June 11th, 1793. As an author, his style has been universally admired; as a minister of the gospel, he was a faithful pastor, and justly merited the esteem and veneration of his flock. His conversation was cheerful, entertaining, and instructive; his manners affable, pleasing, and endearing.

**ROBERVALLIAN LINES**, a name given to certain lines used for the transformation of figures; thus called from their inventor Roberval, an eminent French mathematician, who died in 1675, aged seventy-six. The abbé Gallois, in the Memoirs of the Royal Academy, 1693, observes that the method of transforming figures, explained at the latter end of Roberval's Treatise of Indivisibles, was the same with that afterwards published by James Gregory, in his *Geometria Universalis*, and also by Barrow in his *Lectiones Geometricæ*; and that, by a letter of Torricelli, it appears that Roberval was the inventor of this manner of transforming figures, by means of certain lines, which Torricelli therefore called *Robervallian lines*.

**ROBESPIERRE** (Maximilian Isidore), the most cruel, perhaps, of the demagogues of the French revolution, was born at Arras in 1759. Having lost his father in childhood, he was taken under the protection of the bishop of Arras, who sent him to the college of Louis le Grand; after which he studied the law, and was admitted an advocate in the council of Artois. Early in life he published a Treatise on Electricity, and another on Crimes and Punishments, in which he denied the right of society to put offenders to death. He was, at the beginning of the revolution, elected a member of the states-general, where he obtained the name of 'incorruptible,' by his constant and consistent testimony against political corruption. The Jacobin club raised him to power, when a scene of blood followed, to which hardly a parallel can be found in history. See our article *FRANCE*. Robespierre and his creatures established the terrible committee of public safety, which spread dismay and death throughout France. At length a confederacy was formed against the tyrant, who was arrested July 9, 1794, but not till his lower jaw was broken by a pistol shot in an abortive attempt at suicide. He suffered the next day under the guillotine, amidst the execrations of the multitude. Buonaparte is stated to have said at St. Helena, that Robespierre displayed in his conduct more extensive and enlightened views than have been generally ascribed to him; and that he intended to re-establish order after he had overturned the factions; but, not being powerful enough to arrest the progress of the revolution, he suffered himself to be carried away by the torrent. As a proof of this, the ex-emperor asserted, that when with the army at Nice, he had seen in the hands of Robespierre's brother, letters, in which that demagogue expressed an intention to put an end to the reign of terror. It may, perhaps, be reasonable to conclude that something like principle guided him in the first instance, until, unable to govern the elements of disorder, contending around him, the cruelty of perplexed cowardice at length became his only instrument.

**ROBIGALIA**, festivals held by the ancient Romans, on the 25th of April, when incense was offered, along with the entrails of a sheep and a dog, in honor of

**ROBIGUS** AND **ROBIGO**, a Roman god and goddess, who joined in the preservation of corn from blight.

**ROBIN**, *n. s.* } *Lat. rubecula.* A  
**ROBIN-RED-BREAST.** } bird so named from his  
 red breast; a ruddock.

Up a grove did spring, green as in May,  
 When April had been moist: upon whose bushes  
 The pretty *robins*, nightingales, and thrushes  
 Warbled their notes. *Suckling.*

The *robin-red-breast* till of late had rest,  
 And children sacred held a martin's nest. *Pope.*

**ROBINIA**, false acacia, in botany, a genus of the decandria order, and diadelphia class of plants; natural order thirty-second, papilionaceæ. The calyx is quadrifid; the legumen gibbous and elongated. There are nine species. The most remarkable are,

1. *R. caragana*. The leaves are conjugated, and composed of a number of small folioles, of an oval figure, and ranged by pairs on one common stock. The flowers are leguminous, and are clustered on a filament. Every flower consists of a small bell shaped petal, cut into four segments at the edge, the upper part being rather the widest. The keel is small, open, and rounded. The wings are large, oval, and a little raised. Within are ten stamina, united at the base, curved towards the top, and rounded at the summit. In the midst of a sheath, formed by the filaments of the stamina, the pistil is perceivable, consisting of an oval germen, terminated by a kind of button. This germen becomes afterwards an oblong flattish curved pod, containing four or five seeds, of a size and shape irregular and unequal; yet in both respects somewhat resembling a lentil. This tree grows naturally in the severe climates of Northern Asia, in a sandy soil mixed with black light earth. It is particularly found on the banks of great rivers, as the Oby, Jenisia, &c. It is very rarely met with in the inhabited parts of the country, because cattle are very fond of its leaves, and hogs of its roots; but it is so hardy that the severest winters do not affect it. Gmelin found it in the neighbourhood of Tobolsk, buried under fifteen feet of snow and ice, yet had it not suffered the least damage. Its culture consists in being planted or sown in a lightish sandy soil, which must on no account have been lately manured. It thrives best near a river, or on the edge of a brook or spring; but presently dies if planted in a marshy spot, where the water stagnates. The Tongusian Tartars, and the inhabitants of the northern parts of Siberia, are very fond of the fruit of this tree, it being almost the only sort of pulse they eat. The roots, being sweet and succulent, are very well adapted to fattening hogs; and the fruit is greedily eaten by all sorts of poultry. Linné assures us that, after the pinus fol. quinis, erroneously called the cedar tree of Siberia, this tree, of all that are to be found in Siberia, is most worthy of cultivation.

2. *R. ferax* is a beautiful hardy shrub, and, on account of its robust strong prickles, might be introduced into this country as a hedge plant with much propriety. It resists the severest cold of St. Petersburg, and rises to the height of six or eight feet; does not send out suckers from the root, or ramble so much as to be with difficulty kept within bounds. Its flowers are

yellow, and the general color of the plant a light pleasing green.

ROBINS (Benjamin), an eminent English mathematician, born at Bath in 1707. His parents were unable to give him a proper education; but he procured a recommendation to Dr. Pemberton of London, by whose aid he not only acquired a high knowledge of mathematics, but even commenced teacher of the science. He tried many laborious experiments in projectiles, to ascertain the resistance of the air, a principle which he considered as too much overlooked by writers on gunnery. He also studied the mechanic arts, as depending on mathematical principles; and applied his discoveries to the construction of mills, &c. An attempt being made to explode the method of fluxions, Mr. Robins published, in 1735, *A Discourse concerning the Nature and Certainty of Sir Isaac Newton's Method of Fluxions*. Some objections being made to his manner of defending Sir Isaac, he wrote two or three additional discourses. In 1738 he defended Newton against an objection urged in a Latin piece, entitled *Matho, sive Cosmotheoria puerilis*; and, in 1739, published *Remarks on Euler's Treatise of Motion*, Dr. Smith's *System of Optics*, and Dr. Jurieu's *Discourse of Vision*. In 1739 he published three anonymous political pamphlets, two of which, on the convention with Spain, were much admired, and procured him a very honorable post; for, a committee being appointed to enquire into Sir Robert Walpole's conduct, Mr. Robins was chosen secretary. In 1742 he published his celebrated treatise, entitled *New Principles of Gunnery*, containing the result of many experiments. See PROJECTILES. A treatise being afterwards published in the *Philosophical Transactions*, in opposition to some of his opinions, he presented an account of his work to the society, wherein he took notice of those experiments; and several of his *Dissertations on the Resistance of Air* were read, and his experiments exhibited before the Royal Society, for which they honored him with their gold medal. In 1748 appeared Lord Anson's *Voyage round the World*, which, though the title bears the name of Mr. Walter, is ascribed to Mr. Robins. Mr. Walter, chaplain of the Centurion, had brought it down to his departure from Macao, when he proposed to print it by subscription. But it was first thought necessary to have it reviewed and corrected by an able judge, and this task devolved on Robins, who was authorised to write the whole anew. Hence the entire introduction, the style, and many dissertations in the work, are the sole compositions of Mr. Robins; Mr. Walter's original MS. containing little more than notes of the wind and weather, currents, courses, bearings, distances, qualities of the anchoring grounds, and such particulars as commonly fill up a sailor's account. No work of this kind ever met with a more favorable reception; four large impressions were sold within the year, and it has been translated into most of the languages of Europe. Mr. Robins was soon after desired to compose an apology for the defeat at *Preston-Pans*; which was prefixed to the report of the board of general officers, on their examination

into the conduct of L. G. Sir J. Cope. This was esteemed a master-piece. He afterwards contributed to improve the observatory at Greenwich; and, finally, went out as engineer-general to the East India Company. He arrived in the East Indies in 1750, but fell a sacrifice to the climate in 1751.

ROBINSON (Anastasia), an eminent musician and singer on the stage, afterwards countess of Peterborough. She was the daughter of a portrait-painter, and was born in 1602. She first appeared at the concerts; afterwards at the opera; where her salary and emoluments amounted to £2000 a-year. She died in 1750, aged 88 years.

ROBINSON (Sir Richard), archbishop of Armagh and lord Rokeby, was descended from the Robinsons of Rokeby, in Yorkshire, and born in 1709. He was educated at Westminster, and sent thence to Christ Church, Oxford, in 1726. Dr. Blackburne, archbishop of York, made him his chaplain; and soon after rector of Elton in Yorkshire, and prebendary of Grindal. In 1751 he accompanied the duke of Dorset, lord lieutenant of Ireland, to that kingdom, as his chaplain; and was soon made bishop of Killala. In 1759 he was translated to Leighlin and Fern; in 1761 to Kildare; and in 1765, the duke of Northumberland being lord lieutenant, he was promoted to be primate of all Ireland, lord almoner, and vice-chancellor of the university of Dublin. In 1777 the king created him baron Rokeby; in 1783 prelate to the order of St. Patrick; and in 1785 one of the lords justices. His brother, Sir William, dying in 1785, he succeeded to the title of baronet. He was a public spirited prelate; and, at his own expense, erected a most princely palace at Armagh, and an elegant library. In these works he spent no less than £30,000 for the benefit of the public. He died at Clifton, near Bristol, in 1794.

ROBINSON (Robert), a celebrated dissenting clergyman, born at Swaffham, in Norfolk, October 8th, 1735. His father died in his infancy, and his maternal grandfather, Robert Wilkin, of Mildenhall, esq., who had been displeased with his daughter's marriage, cut him off with half a guinea from his maternal inheritance. His uncle, however, a rich farmer, took him home, and placed him under the rev. Joseph Brett, at Scarning school, in Norfolk, where lord chancellor Thurlow was his school-fellow. He became a disciple of George Whitfield in 1750, and commenced preacher in 1755, but left the Methodists in 1758, and settled at Norwich with a small congregation of Independents. Soon after he became a Baptist, and in 1759 was invited to Cambridge, where he had a small congregation, and a very poor living: but in 1774 the former had increased to 1000. He was even attended by many members of the university. In 1764 his auditors built him a new and elegant meeting-house. He was also invited to lecture in the adjacent villages. He died 9th June, 1790, with the reputation of a man of abilities and integrity. His *Plan of Lectures on the Principles of Nonconformity* has been thought very acrimonious against the church of England. His chief work is his *History of Baptism*, and of the Baptists, published since his death.

ROBINSON (Thomas), a respectable Calvinistic divine, was born at Wakefield, in Yorkshire, in 1749. After receiving the rudiments of a classical education at the foundation school, he removed to Trinity College, Cambridge, and obtained a fellowship of that society in 1772. He was the author of the *Christian System unfolded*, 8vo., 3 vols.; and the very popular *Scripture Characters*, 8vo., 4 vols. He also published some sermons, &c., and died in 1813 at Leicester, in which town he held the living of St. Mary's for thirty-five years.

ROBISON (John), professor of natural history in the university of Glasgow, was born at Boghall, in the county of Stirling, in 1739. He was sent to Glasgow to receive his education, and was soon distinguished for the rapid progress which he made in classical learning. He went, while very young, to the university, where he enjoyed the benefit of the instructions of professors Simson, Leechman, Moore, Smith, and others. Dr. Robert Simson was his tutor in mathematics, and in this class Mr. Robison was soon distinguished beyond any of his fellow students. Among other branches Mr. Robison made himself well acquainted with the modes of algebra; but from professor Simson he derived a peculiar disposition to the study of geometry. Among his fellow students were the celebrated Mr. Windham, with whom he formed an intimate friendship, which continued to the end of his life; Richardson, afterwards eminent as a critic and a professor; and Dr. Gillies, distinguished by his illustrations of Grecian history and politics. Mr. Robison was designed by his parents for the clerical profession; but, though deeply impressed with the truths of religion, he had a great aversion to the professional study of theology. His friends therefore looked round for some situation in which his mathematical talents might be turned to advantage. Dr. Dick, professor of natural philosophy, being in want of an assistant, Mr. Robison, then not nineteen years of age, was recommended by Dr. Smith as a proper person to discharge that office. Dr. Dick, however, thought him too young, and three years after he went to sea as mathematical tutor to Mr. Knowles, eldest son of admiral Knowles. His pupil being appointed lieutenant on board the *Royal William*, Mr. Robison, at his own request, was rated midshipman. Here he spent the three following years, and devoted himself particularly to the study of the art of seamanship, and was sometimes employed in making surveys of coasts and rivers. In this capacity his merit seems to have attracted the notice of lord Anson, then at the head of the admiralty board, by whom he was sent, in 1762, to Jamaica, in order to make trial of Harrison's time-keeper. But on returning from this mission he found his prospects of advancement completely blasted. Lord Anson had died; the vessel on board of which was his pupil, Mr. Knowles, had foundered at sea, and himself with all the crew perished. Admiral Knowles had retired to the country, inconsolable for the loss of his son. He determined, therefore, to return to Glasgow; and admiral Knowles soon after placed under his care his remaining son. At Glasgow he renewed

his studies with great assiduity, but his instructors were changed. Dr. Simson was dead; Dr. Smith had left Glasgow to travel with the duke of Buccleugh. But the place of the latter gentleman had been well supplied by Dr. Reid, and Mr. Robison had also an opportunity of attending the lectures of Mr. Miller on civil law, and of Dr. Black on chemistry. When Dr. Black, in 1769, was called to Edinburgh, Mr. Robison was appointed by the university of Glasgow to succeed him as lecturer on chemistry; and he read lectures on that science for three years with great applause. In 1770 Sir Charles Knowles having gone to Russia, on the invitation of the empress Catharine, then intent on the improvement of her marine, invited Mr. Robison to accompany him as his official secretary, with a salary of £250 a year. As he was still attached to the navy and to his former patron, and as, though lecturing on chemistry, he did not enjoy the rank of a professor, Mr. Robison made no hesitation in accepting the proposal. In 1772 he was appointed, by the Russian admiralty, inspector general of the corps of marine cadets: an academy consisting of upwards of 400 young gentlemen and scholars, under the tuition of about forty teachers. While in this situation, Mr. Robison presented to the admiralty college a plan for rendering more useful the magnificent docks at Cronstadt by means of a steam-engine, which was adopted and executed with success after he had left Russia. Being attached, by his office, to that island, he found it, particularly in winter, to be a dismal solitude, where he was nearly cut off from all society. On this account, having held the appointment about four years, he determined to resign it, and to accept of an invitation from the magistrates and town-council of Edinburgh to be professor of natural philosophy in their university. This situation he filled with great honor to himself as well as benefit to the students of the university till his death, which happened in 1805.

Although Dr. Robison labored under a distressing and painful disorder, during the last eighteen years of his life, his mind was in general active. He is well known to be author of all the most important mathematical and philosophical articles in the third edition of the *Encyclopædia Britannica*, and the supplement to that work. Several of these papers were afterwards thrown into a different form, and published under the title of *Elements of Mechanical Philosophy*. In 1797 this gentleman published a work entitled *Proofs of a Conspiracy against all the Religions and Governments of Europe*, carried on in the Secret Meetings of Free-Masons, Illuminati, and Reading Societies, a work full of declamation and absurdity, but which, owing to the furor of the times, made a great impression, and rapidly passed through several editions. In 1803 Mr. Robison performed a very acceptable service to the public, by giving them an edition of Dr. Black's lectures on the *Elements of Chemistry*, in 2 vols. 4to. When the Royal Society of Edinburgh was incorporated by charter, in 1783, he was chosen by that learned body to be their general secretary, and discharged that office to their entire satisfaction, till a few

days before his death, when the state of his health obliged him to resign it. To their transactions he has contributed several very interesting papers, of which the following is, we believe, a correct list:—1. The orbit and motion of the Georgium Sidus determined directly from observations, vol. i. p. 305. 2. Observations on the places of the Georgian planet made at Edinburgh, with an equatorial instrument, ii. p. 37. 3. On the motion of light, as affected by refracting and reflecting substances, which are also in motion.

**ROBUST**, *adj.* } Fr. *robuste*; Lat. *robustus*. Strong; sinewy;  
**ROBUSTIOUS**, }  
**ROBUSTNESS**, *n. s.* } vigorous; violent; requiring strength: the noun-substantive corresponding.

It offends me to hear a *robustious* periwig-pated fellow tear a passion to tatters, to very rags, to split the ears of the groundlings. *Shakespeare.*

These redundant locks, *Robustious* to no purpose, clustering down, Vain monument of strength. *Milton's Agonistes.*

While I was managing this young *robustious* fellow, that old spark, who was nothing but skin and bone, slipt through my fingers. *Dryden.*

The tenderness of a sprain remains a good while after, and leaves a lasting caution in the man, not to put the part quickly again to any *robust* employment. *Locke.*

Beef may confer a *robustness* on my son's limbs, but will hebetate his intellectuals. *Arbuthnot and Pope.*

Romp-loving miss  
 Is hauled about in gallantry *robust.* *Thomson.*

**ROCA**, a name given to an archipelago of small desert islands on the coast of Venezuela, Colombia. They extend about twenty-three miles from east to west, and ten from north to south. The most northern is worthy of note, from a lofty mountain of white stone, which it has at the west extremity. The others are low, and that which is nearest to the one just mentioned small and flat, producing nothing but grass. These islands are in long. 66° 45' W., lat. 11° 55' N.

**ROC'AMBOLE**, *n. s.* Span. *rocambole*. See **GARLIC**.

*Rocambole* is a sort of wild garlick, otherwise called Spanish garlick; the seed is about the bigness of ordinary pease. *Mortimer.*

Garlick, *rocambole*, and onions, abound with a pungent volatile salt. *Arbuthnot on Alimenta.*

**ROCHE-AL'UM**, *n. s.* Fr. *roche*. A rock. A purer kind of alum.

*Roche-alum* is also good. *Mortimer's Husbandry.*

**ROCHDALE**, a market-town of Lancashire, seated in a valley on the Roch, at the foot of the Yorkshire hills. It has flourishing manufactures of serges, bays, and other woollen and cotton goods. Over the river is a neat stone bridge of three arches. The town consists principally of one long street. Here are also several chapels for Dissenters, and a well endowed school for thirty boys; likewise a theatre and two assembly rooms: a new market-place has been added, and the whole town lighted with gas. The church stands upon a remarkable eminence, to which the ascent from the lower part of the town is by a flight of 118 steps. The manufactories extend about ten miles north of the town, which is fifty-

five miles W. N. W. of York, and 197 N. N. W. of London.

**ROCHEFORT**, a town in the department of the Lower Charente, France, situated in a marshy tract on the right bank of the Charente, about five miles from its embouchure. Though founded only in the latter half of the seventeenth century, it is a place of size, containing about 15,000 inhabitants. Its form is that of a segment of a circle, of which the walls form the circumference, and the river the chord. In the interior the streets are broad, and laid out on a plan of perfect regularity. Nearly in the centre of the town is a spacious Place d'Armes. The objects of interest are the arsenal, cannon foundry, barracks, magazine of naval stores, the docks, the civil and marine hospital, and the navigation school. The harbour, one of the great naval stations of France, is protected by five forts, and well locked in by the land. It is capable, from its depth, of admitting vessels of great size: but line of battle ships take out their lower deck guns to enter the river. At low water vessels are seldom in less than four fathoms depth in this harbour. The docks for building and refitting of vessels, and the stores for their equipment, are very complete. The trade is limited, in great measure, to the coasting and colonial traffic. Here are, however, manufactures of cordage, stoneware, and oil; and also for refining sugar. The ramparts of the town are planted with trees, and form an agreeable walk. Fevers are said to be occasioned here in the autumn by bad water, and the extent of marshes. Since draining a part of the latter they have become less frequent. Twenty miles south-east of La Rochelle, and 100 north of Bourdeaux.

**ROCHEFORT**, a town of France, in the department of the Maine and Loire, on the river Louet. Population 2400. Nine miles south-west of Angers.

**ROCHEFOUCAULT**, a town of France, department of the Charente, on the Tardione, with a castle, which conferred, before the revolution, the title of duke. It has manufactures of leather and linen, and its chief trade is in these articles and in wood. Inhabitants 2400. Twenty miles north-east of Angouleme, and fifty-eight south of Poitiers.

**ROCHEFOUCAULT** (Francis duke of), prince of Marsillac, governor of Poictou, was born in 1603. He was the son of Francis, the first duke of Rochefoucault, and wrote two celebrated works, the one a book of Maxims, and the other, Memoirs of the Regency of Queen Anne of Austria. In the civil war he signalled himself at the battle of St. Antoine. After the civil wars were ended, his house became the rendezvous of all the literati of Paris and Versailles. He died at Paris in 1680, aged sixty-eight.

- **ROCHEJAQUELIN** (Henry de la), a French royalist, distinguished in the war of La Vendée. He was born in 1773, and was the son of the marquis de la Rochejaquelin, a nobleman of Poitou. Having been educated at the military school of Sorèze, he became one of the constitutional guard of Louis XVI. His father quitted France, and our young hero Paris, after the insurrection of the 10th of August 1792. He re-

sided with his relative, the marquis de Lescure, near Parthenay, in March 1793, when, the inhabitants of the surrounding country rising in arms in favor of the royal cause, La Rochejaquelein putting himself at their head, they attacked and defeated the republicans under general Quétineau, at Aubiers. The marquis de Lescure now took the field with the royalists, who were at first very successful; but on the 18th of October they were defeated at Chollet, and their generals, Lescure, Bonchamps, and d'Elbée, mortally wounded. La Rochejaquelein was at this time chosen commander-in-chief of the Vendéans, and was obliged, against his own judgment, to retreat beyond the Loire. He continued, under great disadvantages, for some time to oppose the republicans; but was at length killed in defending the village of Nouaille, March 4th, 1794. In the recent memoirs of the marchioness de la Rochejaquelein, the widow of his younger brother, this young soldier is represented as resembling a knight of chivalry; and, after making all allowances for the friendship of his historian, he appears to have possessed extraordinary qualifications for the part he played.

ROCHELLE, LA, a town of Lower Charente, France, the capital of that department, is situated in a plain at the bottom of a gulf of the Atlantic. Its form is nearly oval, and its length from north to south, exclusive of the suburbs, about three-quarters of a mile; its breadth above half a mile. The fortifications of the celebrated Vauban are in good condition, and consist of nineteen large bastions, and eight half moons, enclosed by a moat and covered way. On the side of the sea it has a massy old wall, flanked with large towers. The streets are broad, and in general straight, and the houses spacious throughout the town: they are almost all supported in front by arcades, which, by concealing the pedestrians, cause an apparent dulness in the streets. The Place d'Armes, or Place du Chateau, consists of a spacious area planted with trees, and commands a fine view of the roadstead. The principal public buildings are the cathedral, hospital, orphan-house, and exchange: here are also several scientific institutions, a navigation school, and a cabinet of natural history.

Rochelle has an excellent road, and a haven, formed by a dike and basin for merchant vessels. Its entrance is defended by two old Gothic towers of great height, and is crossed by a ponderous iron chain. The trade to the colonies in wines, brandy, flour, linen; taking in return sugar, coffee, cotton, and all kinds of produce, is considerable. To ports of Europe the chief articles of export are brandy and bay salt; its imports from them are trifling. Glass, stoneware, and sugar, are the chief manufactures.

La Rochelle was, in the thirteenth century, for some time in the possession of the English. In the sixteenth it became a strong hold of the Protestants, and governed itself for some time as a republic. It was several times besieged by the Catholics without success, until 1637, when it was taken by Louis XIII. after a siege of thirteen months, during which the inhabitants suffered all the horrors of famine. It was to exclude all its supplies at this time that cardinal

Richelieu caused the construction of a mole across the roadstead, about a mile and a half in length: the remains of which are still visible. Its fortifications were razed on that occasion, but they were re-erected under Louis XIV. The town was the birth-place of the naturalist Reaumur, and is seventy-eight miles south of Nantes, and 335 south-west of Paris.

ROCHESTER, a city of Kent, situated on the Medway, seven miles and a half north of Maidstone, and thirty south-east from London. It was a Roman station, and many Roman coins have been found about it. It has three parish churches, besides the cathedral. This city was made a bishop's see by king Ethelbert in 604, and was called by the Saxons Roffcaster: whence its present name. In 676 it was sacked by Eldred king of Mercia; in 839 and 885 besieged by the Danes, but rescued by king Alfred. About 100 years after it was besieged by king Ethelred, and compelled to pay £100. In 999 it was taken and plundered by the Danes. In 1088 it was besieged and taken by William Rufus. In king John's time it was taken from the barons after three months' siege; and in 1256 its castle, founded by William the Conqueror, was stormed and taken by the barons, under the French king's son. In the reign of Henry III. it was besieged by Simon Montford, who burnt its then wooden bridge and tower, and spoiled the church and priory. In 1281 its old wooden bridge was carried off by the ice in a sudden thaw after a frost which had made the Medway passable on foot. Another was built in the reign of Richard II., but pulled down again on a rumor of an invasion from France. It was afterwards restored, but so often required expensive repairs, by reason of the rapid course of the river under it, that in the reign of Edward III. it was resolved to build a new bridge of stone; which was begun, and completed, at the expense of Sir John Cobham and Sir Robert Knolles, Edward III.'s generals, out of the spoils they had taken in France. The town is governed by a mayor, recorder, twelve aldermen, twelve common-councilmen, a town clerk, and inferior officers. To its cathedral belong a dean and six prebendaries. The present castle of Rochester was one of those founded by William the Conqueror, to keep in awe his new subjects; but there seems every reason to believe that a prior one existed on the same site, frequent mention being made of the *Castrum Roffense* in the Saxon annals. He committed to Odo, bishop of Baieux, the execution of the new work, and the custody of the fortress; but, that prelate proving unworthy of his trust, he was afterwards seized, and sent as a prisoner to the castle of Rouen, in Normandy, where he continued to the accession of William Rufus, who restored him to his dignities and possessions; a favor which he shortly after ungratefully repaid by raising an insurrection in favor of the king's brother, Robert, duke of Normandy. Rufus, upon this, laid siege to Rochester castle, and, having forced the garrison to surrender, banished the bishop from his dominions. During this siege the buildings sustained considerable injury, which the king enjoined bishop Gundulph and the prior of Rochester to repair,

perhaps on account of their having shown some attachment to the rebellious cause. Gundulph accordingly not only renovated the walls, but laid the foundation of the great square tower, which yet perpetuates his name, and entitles him to rank among the most eminent architects of Anglo-Norman times. Several estates in this county hold of Rochester castle by the ancient tenure of castle guard. On St. Andrew's day, old style, a banner is hung out at the house of the receiver of rents; and every tenant who does not then discharge his arrears is liable to have his rent doubled, on the return of every tide of the Medway, till the whole is discharged.

Rochester castle stands at the south-western angle of the city, on an eminence rising abruptly from the river Medway, which preserve from attack on the west, whilst its south, east, and north sides were defended by a broad and deep ditch. The outward walls, which formed an irregular parallelogram, 300 feet in length, were strengthened by several square and round towers; but these, as well as the walls themselves, are now verging to a state of ruin. The most perfect are on the east side, and at the south-east angle; that at the angle was semi-circular, and rose boldly from the ditch, which is now almost filled up. The principal entrance was on the north-east, and was defended by a tower gateway, with outworks at the sides. The keep, or great tower already mentioned, as founded by bishop Gundulph, occupies the south-east portion of the castle area. It is of a quadrangular form, seventy feet square at the base, and is so planned that its angles correspond with the four cardinal points of the compass. The walls on the outside are built inclining inwards from the base, and were in general twelve or thirteen feet thick. Near the centre, on each side, is a pilaster buttress, ascending from the base to the roof; and at the angles are projecting towers, three of them square, and the fourth semi-circular, which rise twelve feet above the roof. The entrance to this part of the castle was most difficult and intricate, and displayed much architectural ingenuity. The first ascent was by a flight of twelve steps, leading to an arched gate and covered way; beneath which a flight of seven steps led forward to a draw-bridge, that connected with the arched gateway of the entrance tower; this opened into a vestibule, between which and the keep there were no other avenues of communication than by a third arched passage in the thickness of the wall. This latter, being the immediate inlet to the body of the keep, was defended by a massive gate and portcullis, the hinges and grooves of which yet remain; and in the roof are openings for the purpose of showering down destruction on the assailants.

The interior of the keep is divided into two nearly equal parts by a strong wall, with arched door-ways of communication on each floor. In the centre of this wall is a circular hole for a well of considerable depth, neatly wrought, and open from the bottom to the very top of the keep. This tower consisted of three floors, independent of the basement story; but these floors were removed when the castle was dismantled in the reign of James I. The lowest apartments were

two dark and gloomy rooms, in which the garrison stores were probably deposited. At the north-east angle is a circular winding staircase, which ascends to the summit; and near it is a small arched door-way, leading to a narrow vaulted apartment underneath the little tower, supposed to have been a dungeon for criminals. The first floor appears to have been allotted for the accommodation of servants and inferior attendants; the second floor contained the state apartments; and the third was designed for a chapel, and for bed-rooms for the family. The roof of the keep is now entirely destroyed; but it most probably consisted of a platform on a level with the top of the wall within the parapet; the latter was about five feet high, and had embrasures about two feet wide.

The cathedral is situated on the east of the castle, and a little south of the High Street. From the mixed style of its architecture it appears to have been the work of different ages. It is in the form of a cross, and is divided into a nave, aisles, two transepts, and a choir, with a low tower, and a spire rising at the intersection of the nave and great transept. The greater part of the nave and west front display the massive character of the early Norman and Saxon architecture. The west entrance is particularly worthy of attention: the remaining parts of the cathedral are comparatively plain in their exterior. Entering the nave by the western door, the massive Norman style is conspicuous in the first five columns on each side, all of them supporting circular arches, decorated with zig-zag mouldings. The roof is of timber, with knees supported on corbels, the fronts of which are carved into figures of angels sustaining shields, on which are the arms of the city, the see, and the priory of Rochester, as well as those of the archbishopric of Canterbury. The great tower is supported by four obtusely-pointed arches, resting on solid masonry, environed by slender columns of Petworth marble. The cathedral extends in length 306 feet from east to west. The breadth of the nave, with the side aisles, is seventy-five feet, and that of the choir nearly the same. The western transept is 122 feet, and the eastern ninety feet long; the west front is ninety-four feet wide, and the great tower 156 feet high. Several of the monuments in the cathedral are curious from their antiquity and workmanship.

For the maintenance of the bridge certain lands are allotted by parliament, to which Rochester has sent members from the first. The town-house, built in 1687, for the courts, assizes, and sessions, and the charity school, are two of the best public buildings here. In the cemetery, on the north side of the cathedral, is the church belonging to the parish of St. Nicholas. The present fabric, consisting of a nave and two side aisles, was erected about the year 1620. At the entrance into the High Street next the bridge, are the remains of St. Clement's church, now converted into dwelling-houses, the parish having been united with that of St. Nicholas. The town-hall, erected in 1687, is a handsome brick structure, supported by stone Doric columns. The entrance to the hall is by a spacious staircase,

the ceiling of which, as well as that of the hall, is curiously ornamented. Here the city business is transacted, and the assizes for the county are sometimes held. The clock-house was built in 1686, at the expense of Sir Cloudesley Shovel, who also gave the clock. At the bottom of Chaldegate Street stands a large and commodious poor-house. The main street is wide, and well paved. The town, within the walls, consists of one main street, but within its liberties many buildings have been erected, and improvements have been made, and are still making. A mathematical school was founded here, and an almshouse for lodging six poor travellers every night, and allowing them 4d. in the morning when they depart, except persons contagiously diseased, rogues, and proctors. The Roman Watling Street runs through this town from Shooter's Hill to Dover. The mayor and citizens hold an admiralty court once a year for regulating the oyster-fishery in the creeks and branches of the Medway within their jurisdiction, and for prosecuting offenders. The bridge was repaired in 1744, and pallisadoed with new iron rails. Market on Fridays.

ROCHESTER, a post-town of Strafford county, New Hampshire, on the west side of Salmon Fall River, twenty-two miles north-west of Portsmouth. Near the centre of the town there is a village called Norway Plains, containing a meeting-house, court-house, and several stores. There is also a cotton manufactory in the town. One term of the court of common pleas is held here annually.—Also a post-town of Plymouth county, Massachusetts, on Buzzard's Bay, twenty miles south-west of Plymouth, and forty-eight south of Boston. Here are some iron works.—And a post town of Ulster county, New York, twenty miles south-west of Kingston.

ROCHESTER, EARL OF. See WILMOT.

ROCH'ET, *n. s.* Fr. *rochet*; low Lat. *rochetum*, from *roccus*, a coat. A surplice; the white upper garment of a priest.

What zealous phrenzy did the senate seize,  
That tare the *rotchet* to such rags as these!

*Cleveland.*

ROCHFORD, a market-town and parish of Essex, situated in a small rivulet called the Broomhill, over which it has two wooden bridges. It is fifteen miles east by south from Billericay, and thirty-nine east from London. The houses are for the greater part irregular and ill-built. The parish church stands half a mile from the town, and is a plain building. The market-house is a mean timber structure, in which the petty sessions for the Rochford division of Essex are held. This place is rendered remarkable on record for its lawless court. See LAWLESS COURT. The market is on Thursdays for cattle, corn, and provisions. Raleigh, in this vicinity, though now an inconsiderable village, was formerly a market town, and the head of the barony of Suene, a powerful Anglo-Saxon Dane, who is reported to have built a castle here, of which some important earth-works still remain. These consist of a mount, of an oval shape at the base, which is environed by a double ditch and rampart.

ROCK, *n. s.* } Fr. *roc, roche*; Ital. *rocca*;  
ROCK'DOE, } Span. *roca*; Port. *rocha*; (à  
ROCK'LESS, } Gr. *ρωξ*.—Minsheu.) A mass  
ROCK'RUBY, } of stone; a stony mass fixed  
ROCK'SALT, } in the earth; protection; de-  
ROCK'WORK, } fence: a rock-doe is a doe  
ROCK'Y, *adj.* } that frequents the rocky heights  
of the Alps: rockless, devoid of rocks: rock-  
ruby, the garnet; a hard stone: rock-salt, mine-  
ral salt: rock-work, strong or rugged work in  
imitation of rocks; a natural wall of rock:  
rocky, abounding with rocks; strong; stony.

Val de Compare presenteth her *rocky* mountains.

*Sandys.*

The splitting *rocks* cow'r'd in the sinking sands,  
And would not dash me with their ragged sides.

*Shakspeare.*

I, like a poor bark, of sails and tackling reft,  
Rush all to pieces on thy *rocky* bosom.

*Id.*

There be *rock* herbs; but those are where there is  
some mould.

*Bacon's Natural History.*

Though the reeds of Egypt break under the hand  
of him that leans on them, yet the *rock* of Israel will  
be an everlasting stay.

*King Charles.*

Such destruction to withstand, he opposed the  
*rocky orb*

Of ten-fold adamant, his ample shield.

*Milton.*

Distilling some of the tinted liquor, all that came  
over was as limpid and colourless as *rock* water, and  
the liquor remaining in the vessel deeply ceruleous.

*Boyle.*

Make the bold prince  
Through the cold north and *rocky* regions run.

*Waller.*

A crystal brook  
Is weedless all above, and *rockless* all below.

*Dryden.*

The vallies he restrains  
With *rocky* mountains.

*Id.*

Nature lodges her treasures in *rocky* ground.

*Locke.*

Pigeons or doves are of several sorts; as wood  
pigeons and *rock* pigeons.

*Mortimer's Husbandry.*

The *rock-doe* breeds chiefly upon the Alps: a crea-  
ture of admirable swiftness; and may probably be  
that mentioned in the book of Job: her horns grow  
sometimes so far backward as to reach over her but-  
tocks.

*Grew's Museum.*

These lesser *rocks*, or great bulky stones, are they  
not manifest fragments?

*Burnet.*

The garden is fenced on the lower end, by a natu-  
ral mound of *rockwork*.

*Addison.*

Of amber a nodule, invested with a coat, called  
*rock* amber.

*Woodward on Fossils.*

*Rock-ruby* is of a deep red, and the hardest of all  
the kinds.

*Id.*

Two pieces of transparent *rock-salt*; one white,  
the other red.

*Id.*

Ye darksome pines, that o'er yon *rocks* reclined,  
Wave high, and murmur to the hollow wind.

*Pope.*

Till a' the seas gang dry my dear,

And the *rocks* melt wi' the sun:

I will love thee still, my dear,

While the sands o' life shall run.

*Burns.*

Rock, *n. s.* Goth. and Swed. *rock*; Ital. *roc-  
ca*; Span. *rucca*. A distaff from which wool is  
spun; a roll of flax or wool.

A learned and a manly soul  
I purposed her; that should with even powers,  
The *rock*, the spindle, and the sheers controul  
Of destiny, and spin her own free hours.

*Ben Jonson.*



On the *rock* a scanty measure place  
 Of vital flax, and turn the wheel apace. *Dryden*.  
 Flow from the *rock*, my flax, and swiftly flow,  
 Pursue thy thread, the spindle runs below. *Parnel*.  
 Rock, *v. a.* } Fr. *rocquer*; Dan. *rokke*. To  
 Rock'ER, *n. s.* } shake; agitate; to move back-  
 wards and forwards; lull by rocking; be agi-  
 tated; reel to and fro: the noun substantive cor-  
 responding.

Come, take hand with me,  
 And rock the ground whereon these sleepers be.  
*Shakspeare.*

Sleep *rock* thy brain,  
 And never come mischance between us twain. *Id.*  
 Leaning her head upon my breast,  
 My panting heart *rocked* her asleep. *Suckling*.  
 My bloody resolutions,  
 Like sick and froward children,  
 Were *rocked* asleep by reason. *Denham*.

If, by a quicker *rocking* of the engine, the smoke  
 were more swiftly shaken, it would, like water, vi-  
 brate to and fro. *Boyle*.  
 The wind was laid; and the whispering sound  
 Was dumb; a rising earthquake *rocked* the ground.  
*Dryden*.

His fellow, who the narrow bed had kept,  
 Was weary, and without a *rock*er slept. *Id.*  
 While his secret soul on Flanders preys,  
 He *rocks* the cradle of the babe of Spain. *Id.*  
 A living tortoise, being turned upon its back, could  
 help itself only by its neck and head, by pushing  
 against the ground to *rock* itself as in a cradle, to  
 find out the side towards which the inequality of the  
 ground might more easily permit to roll its shell.

*Ray on the Creation*.  
 The *rocking* town  
 Supplants their footsteps; to and fro they reel  
 Astonished. *Philips*.  
 like this *rocking* of the battlements. *Young*.  
 Ae night the storm the steeples *rocked*,  
 Poor labour sweet in sleep was locked,  
 While burns, wi' snawy wreaths up-choked,  
 Wild eddying swirl,  
 Or through the mining outlet bocked,  
 Down headlong hurl. *Burns*.

ROCK BASINS are cavities or artificial basins  
 of different sizes, from six feet to a few inches  
 diameter, cut in the surface of the rocks for the  
 purpose, as is supposed, of collecting the dew  
 and rain pure as it descended from the heavens,  
 for the use of ablutions and purifications, pre-  
 scribed in the Druidical religion; these, espe-  
 cially the dew, being deemed the purest of all  
 fluids. There are two sorts of these basins, one  
 with lips or communications between the different  
 basins, the other simple cavities. The lips are  
 as low as the bottom of the basins, which are  
 horizontal, and communicate with one somewhat  
 lower, so contrived that the contents fell by a  
 gradual descent through a succession of basins  
 either to the ground, or into a vessel set to re-  
 ceive it. The basins without lips might be in-  
 tended for reservoirs to preserve the rain or dew  
 in its original purity without touching any other  
 vessel, which was perhaps used for the Druid to  
 drink, or wash his hands, previous to officiating  
 at any high ceremony. Some of those basins  
 are so formed as to receive the head and part of  
 the human body; one of this kind is found on  
 a rock called king Arthur's bed, in the parish of  
 North Hall in Cornwall, where are also others,

called by the country people Arthur's troughs,  
 in which they say he used to feed his dogs.

ROCK CRYSTAL. See CRYSTAL.

ROCK SALT. See SALT.

ROCK'ET, *n. s.* Ital. *rocchetto*. An arti-  
 ficial firework. See PYROTECHNY, and below.

When bonfires blaze, your vagrant works shall rise  
 In *rockets*, till they reach the wondering skies.

*Garth*.  
 Every *rocket* ended in a constellation, strowing the  
 air with a shower of silver spangles. *Addison*.

ROCK'ET, *n. s.* Lat. *eruca*. A plant, of a pe-  
 culiarily fetid smell.

*Rocket* is one of the sallet furniture. *Mortimer*.

ROCKETS, SIR WILLIAM CONGREVE'S, are a  
 modern species of war rockets, called after  
 the name of their inventor. They differ of course  
 from the common rocket, as well in their mag-  
 nitude and construction as in the powerful nature  
 of their composition; which is such, that with-  
 out the incumbrance of any ordnance (the rocket  
 itself containing the propelling power) balls,  
 shells, case-shot, and carcasses, may be projected  
 to the distance of from 1000 to 3000 yards,  
 which renders them a most efficacious species of  
 artillery.

They are of various dimensions, as well in  
 length as in calibre, and are differently armed  
 according as they are intended for the field, or  
 for bombardment; carrying, in the first instance,  
 either shells or case shot, which may be exploded  
 at any part of their flight, spreading death and  
 destruction amongst the columns of the enemy;  
 and in the second, where they are intended for the  
 destruction of building, shipping, stores, &c., they  
 are armed with a peculiar species of composition,  
 which never fails of destroying every combustible  
 material with which it comes in contact. The  
 latter, called carcass-rockets, were first used at  
 Boulogne, their powers having been previously  
 demonstrated in some experiments made at  
 Woolwich by Sir William Congreve in the pre-  
 sence of Mr. Pitt and several of the cabinet  
 ministers. Sir Sidney Smith was ordered to  
 command the expedition intended for this pur-  
 pose; but from the lateness of the season, it  
 being near the end of November before the pre-  
 parations were completed, nothing was done that  
 year. In 1806 Sir William renewed his propo-  
 sition for the attack of Boulogne by rockets,  
 which was ordered to be put in execution after  
 lord Moira, at that time master-general of the  
 ordnance, and lord Howick, first lord of the ad-  
 miralty, had satisfied themselves of the efficacious  
 nature of the weapon. The attack was accord-  
 ingly made under the command of commodore  
 Owen, late in October 1806; having been put  
 off during the summer months in consequence  
 of the negotiations for peace. The town was set  
 on fire by the first discharge, and continued  
 burning for nearly two days: it was supposed,  
 also, that some shipping were destroyed, but the  
 greater part of the rockets certainly went over  
 the basin into the town. Carcass-rockets have  
 since been used in various expeditions under the  
 immediate inspection of their inventor.

After the siege of Copenhagen they were  
 ordered by lord Chatham, the master-general of  
 the ordnance, to be reported upon by a commit-

tee of field-officers of artillery who had witnessed their effect in that bombardment, and who pronounced them to be 'a powerful auxiliary to the present system of artillery.' Indeed the powers of this weapon are now established upon the best of all testimonies, that of the enemy; a striking instance of which occurred at the siege of Flushing, where general Monnet, the French commandant, made a formal remonstrance to lord Chatham respecting the use of them in that bombardment.

It is not, however, in bombardment only that this species of artillery may be advantageously employed; their powers in the field having been demonstrated to be equally irresistible. The crown prince of Sweden was the first general who bore testimony to their effects in this service; a small corps of rocketeers, under the command of captain Bogue of the British artillery, having been attached to a division of the allied armies, which, in the ever memorable battle of Leipsic, gloriously maintained the honor of the British arms. They were afterwards employed with great effect when the British army, under the command of the duke of Wellington, crossed the Adour. In consequence his royal highness the prince regent commanded the formation of a rocket corps, which took place on the 1st of January 1814, by augmentation to the regiment of royal artillery.

The form of all the different kinds of these rockets is cylindrical, and they are composed of strong metallic cases, armed, as we have before stated, either with carcass composition for bombardment and conflagration, or with shells and case-shot for field service. They are, however, of various weights and dimensions, from the eight-inch carcass, or explosion rocket, weighing nearly 3 cwt., to the six pound shell-rocket, which is the smallest size used in the field. The sticks which are employed for regulating their flight are also of different lengths, according to the size and service of the rocket; and which, for the convenience of carriage, are stowed apart from the rocket, and so contrived as to consist of two or more parts, which are connected to it, and to each other, when requisite, with the utmost expedition.

The ammunition is divided into three classes, heavy, medium, and light; the former including all those of above forty-two pounds, which are denominated according to their calibre, as eight-inch, seven-inch, six-inch, &c., rockets; the medium include all those from forty-two pound to twenty-four pound rocket; and the light from the eighteen-pounder to the six-pounder inclusive. The carcass-rockets are armed with strong iron conical heads, containing a composition as hard and solid as iron itself, and which, when once inflamed, bids defiance to any human effort to extinguish it; and consequently involves, in an inextinguishable flame, every combustible material with which it comes in contact. The forty-two-pounder and thirty-two-pounder carcass-rockets are those which have hitherto been chiefly employed in bombardments: the penetration of the thirty-two pound carcass-rocket in common ground is nine feet; and in some instances where they have been employed, they

have been known to pierce through several floors, and through the sides of houses: this is the smallest rocket used in bombardment, and the largest employed in the field; the more usual size for the latter service being the twenty-four, eighteen, twelve, and six-pounders. The ranges of the eight-inch, seven-inch, and six-inch rockets are from 2000 to 2500 yards; and the quantity of combustible matter, or bursting powder, from twenty-five pounds to fifty pounds; and from their weight, combined with less diameter, they possess a greater power of penetration than the heaviest shells, and are therefore equally efficient for the destruction of bomb-proofs, or the demolition of strong buildings; so that the facility of application, on which the inventor has hitherto rested the merit of the rocket system, is not its only excellence; for it thus appears that it actually will propel heavier masses than can be done by any other means, that is to say, masses, to project which it would scarcely be possible to cast, much less to transport mortars of sufficient magnitude. The largest rocket that has yet been constructed has not, we believe, exceeded 3 cwt.; but Sir William Congreve had in contemplation others of much superior magnitude, weighing from half a ton to a ton weight, which, being driven in very strong cast-iron cases, may possess such force that, when fired along trenches cut to the foot of the glacis, from the nearest point of the third parallel, against the revetement of any fortress, even unimpaired by a cannonade, it shall, by its mass and form, pierce the same; and, having pierced it, shall with one explosion of several barrels of gunpowder, with which it is loaded, blow such portion of the masonry into the ditch, as may, with very few rounds, complete a practicable breach.

The forty-two and thirty-two pounders are those, as we have before stated, which have hitherto been principally used in bombardment, and which, for the general purposes of that service, are found quite sufficient, as they will convey from seven pounds to ten pounds of combustible matter each, and have a range of upwards of 3000 yards. The thirty-two pounder rocket may be considered as the medium rocket, being the smallest used in bombardment as a carcass or explosion rocket, and the largest used with shot or shell in the field; but as the twenty-four pounder is very nearly equal to it in all its applications in the latter service, being quite equal to the propelling of the Cohorn shell, or twelve pounder shot, it is, from the saving in weight, generally preferred to the thirty-two-pounder. The eighteen-pounder, which is the first of the light nature of rockets, is armed with a nine-pound shot or shell; the twelve-pounder with a six-pound ditto; the nine-pounder with a grenade; and the six-pounder with a three-pound shot or shell. From the twenty-four-pounder to the nine-pounder rocket, inclusive, a description of case-shot rocket is formed of each nature, armed with a quantity of musket or carbine balls, put into the top of the cylinder of the rocket.

*The rocket light ball*, invented by Sir William Congreve, is a species of light ball thrown into the air by means of one of his rockets; where, having reached the summit of the rocket's ascent,

it is detached from it by an explosion, and remains suspended in the air by a small parachute, to which it is connected by a chain. A permanent and brilliant light is thus obtained, and suspended in the air for five minutes at least, so as to afford time and light sufficient to observe the motions of an enemy either on shore or at sea; where it is particularly useful in chasing, or for giving distant and more extensive night signals. It is to be observed that nothing of this kind can be obtained by the projectile force of either guns or mortars, because the explosion infallibly destroys any construction that could be made to produce the suspension in the air.

The *floating rocket carcass* is another of the inventor's applications of his rocket, and of the parachute, for the purpose of conveying combustible matter to distances far beyond the range of any known projectile force; at the same time that it is cheap, simple, and portable. Like the light ball it is thrown into the air attached to a rocket, from which being liberated at its greatest altitude, and suspended to a small parachute, it is driven forward by the wind, and will, in a moderate breeze, afford ranges at least double those of the common carcass; and may, therefore, for naval purposes, from a blockading squadron, be thrown in great quantities, by a fair wind, against any fleet or arsenal, without the smallest risk, or without approaching within range either of guns or mortars. Thus, in a blockade, a few years back, of the Russian fleet at Baltic Fort, it might have been continually used, at all events, with great prospect of success, and certainly where no other means of annoyance could be applied. The rocket containing this carcass is not larger than the thirty-two pounder carcass-rocket; and the whole expense, added to the rocket, does not exceed five shillings; nor are the approaches of the carcass itself necessarily visible by night, as it may be so arranged as not to inflame till some time after it has settled. It is evidently, therefore, capable of becoming a very harassing weapon, with a great chance of doing as much mischief as any other carcass amongst large fleets and flotillas, by lodging unperceived in the rigging, or lighting on extensive arsenals, in situations where no other means of annoyance whatever exists.

ROCKINGHAM, a market town of Northamptonshire, eighty-three miles from London, situated on the river Welland. It has a charity school, a market on Thursday, and a fair on September 8th, for five days. William the Conqueror erected a castle here, which was garrisoned by Sir Lewis Watson, for king Charles I., who was created in 1644, baron Rockingham. Its forest was reckoned one of the largest and richest in the kingdom; it extended in the time of the ancient Britons almost from the Welland to the Nen, and was noted formerly for iron works, great quantities of flags, i. e. the refuse of the iron ore, being met with in the adjacent fields. It extended, according to a survey in 1641, nearly fourteen miles in length, from the west end of Middleton Woods to the town of Wandsford, and five miles in breadth, from Brigstock to the Welland; but is now dismembered into parcels, by the interposition of fields and

towns, and is divided into three bailiwics. In several of its woods a quantity of charcoal is made of the tops of trees. Market on Thursday.

ROCKINGHAM, a township of the United States, on the Connecticut, Windham county, Vermont.

ROCKINGHAM, a county of the United States, in the south-east part of New Hampshire, bounded north-east by Strafford county, east by the Atlantic, south by Massachusetts, and west by Hillsborough county. Chief towns, Portsmouth, Exeter, and Concord.

ROCKINGHAM, a county of the central part of Virginia, bounded north-east by Hardy and Shenandoah counties, south-east by Orange and Albemarle counties, south-west by Augusta county, and W. N. W. by Pendleton county. Also a county of the United States, on the north side of North Carolina. It lies west of Caswell county, and is watered by the Dan. There is a mineral spring in this county, which is much resorted to.

ROCKY MOUNTAINS, or STONY MOUNTAINS, a long and broad range of mountains of North America. Long. 112° W. They divide the waters which flow east into the Missouri and Mississippi, from those which flow west into the Pacific Ocean.

ROCKY RIVER, a river of Ohio, which runs into lake Erie, nine miles west of the Cuyahoga.

ROCKY, or ROCK RIVER, or ROCHE, a river which rises in the north-west territory, runs through the north-west part of the Illinois territory, and flows into the Mississippi, 160 miles above the Illinois. Length about 200 miles.

ROD, *n. s.* Belg. *roede*. A long twig or pole; any thing long and slender; a sceptre; an instrument of measurement, or of correction.

If he be but once so taken idly roguing, he may punish him with stocks; but if he be found again so loitering, he may scourge him with whips or rods.

*Spenser on Ireland.*

She had all the royal makings of a queen;  
As holy oil, Edward Confessor's crown,  
The rod and bird of peace.

*Shakspeare. Henry VIII.*

I am whipt and scourged with rods,  
Nettled, and stung with pismires, when I hear  
Of Bolingbroke. *Id. Henry IV.*

In this condition the rod of God hath a voice to be heard, and he, whose office it is, ought now to expound to the sick man the particular meaning of the voice.

*Hammond.*

Grant me and my people the benefit of thy chastisements; that thy rod, as well as thy staff, may comfort us.

*King Charles.*

The past'ral reed of Hermes, or his opiate rod.

*Milton.*

Some chuse a hazel rod of the same year's shoot, and this they bind on to another straight stick of any wood, and, walking softly over those places where they suspect the bowels of the earth to be enriched by metals, the wand will, by bowing towards it, discover it.

*Boyle.*

They trembling learn to throw the fatal dart,  
And under rods of rough centurions smart.

*Dryden.*  
Let the fisherman

Increase his tackle, and his rod retie.

*Gay.*

As soon as that sentence is executed, these rods, these instruments of divine displeasure, are thrown into the fire.

*Atterbury.*

Decempeda was a measuring rod for taking the dimensions of buildings, and signified the same thing as pertica, taken as a measure of length. *Arbutnot.*

Haste, ye Cyclops, with your forked rods,

This rebel love braves all the gods,

And every hour by love is made

Some heaven-defying Encelade.

*Granville.*

A wit's a feather, and a chief a rod;

An honest man's the noblest work of God. *Pope.*

O gentle sleep, I cried,

Why is thy gift to me alone denied?

Mildest of beings, friend to every clime,

Where lies my error, what has been my crime?

Beasts, birds, and cattle, feel thy balmy nod:

The drowsy mountains wave, and seem to nod:

The torrents cease to chide, the seas to roar,

And the hushed waves recline upon the shore.

*Harte.*

RODNEY (George Brydges, lord Rodney), was born in 1718. His father was a naval officer, commanding, at the time of his son's birth, the yacht in which the king, attended by the duke of Chandos, used to pass to or from Hanover, and he asked and obtained leave to call his infant son George Brydges. The royal and noble god-fathers advised captain Rodney to educate his boy for his own profession, promising to promote him as rapidly as the merit he should display, and the regulations of the navy, would permit. In 1751, accordingly, we find him in the rank of a commodore, sent out to make accurate discoveries respecting an island which was supposed to lie about 50° N. lat., and about 300 leagues west of England; but he returned without having seen any such island. In the war which soon followed this voyage of discovery, he was promoted to the rank of a rear-admiral, and was employed to bombard Havre de Grace; which in 1759 and 1760 he considerably damaged, together with the shipping. In 1761 he was sent on an expedition against Martinico, which was reduced in the beginning of 1762, and about the same time St. Lucia surrendered to captain Harvey. In reward for his services, he was created K. B.; but, in consequence of extravagance, his circumstances became so embarrassed that he was obliged to fly from his country. He was in France when that court took a decided part with America against Great Britain; and the king of France through the duke de Biron offered him a high command in the French navy, if he would carry arms against his own country; an offer which he rejected with indignation. When the divisions which the mutual recriminations of admiral Keppel and Sir Hugh Palliser excited in the British navy made it difficult for the ministry to procure experienced and popular commanders for their fleets, lord Sandwich offered him the chief command off the Leeward Isles, and he hoisted his flag, December 1779, on board the Sandwich. His first exploit was in January 1780, when he took nineteen Spanish transports bound to Cadiz from Bilboa, with a sixty-four gun ship and five frigates. On the 16th of January he fell in with the Spanish fleet, consisting of eleven sail of the line, under don John de Langara; of which one was blown up during the engagement, five were taken and carried into Gibraltar, among which was the admiral's ship;

and the rest were much shattered. In April, 1780, he fell in with the French fleet, under admiral Guichen, at Martinico, whom he engaged; though from the shattered state of his own fleet, and the unwillingness of the enemy to risk another action, he took none of their ships. His successful efforts during 1780 were generally applauded. He received the thanks of both houses of parliament, and addresses of thanks from various parts of Great Britain, and from the islands to which his victories were more particularly serviceable. In 1781 he continued his exertions, with much success, in defending the West India Islands; and, along with general Vaughan, he conquered St. Eustatius. On the 12th of April, 1782, he came to a close action with the French fleet under count de Grasse; during which he sunk one ship, and took five, of which the admiral's ship, the Ville de Paris, was one. Peace was made in 1782; but, as a reward for his numerous services, he received a pension of £2000 a-year for himself and his two successors. He had long before been created a baronet, and was justly promoted to the peerage, by the title of baron Rodney of Stoke, Somersetshire, and made vice-admiral of Great Britain. Lord Rodney had been twice married; first to the sister of the earl of Northampton; and secondly, to the daughter of John Clies, esq. with whom he did not reside for several years before his death, which happened on the 24th of May, 1792. In 1783 the house of Assembly, in Jamaica, voted £1000 towards erecting a marble statue to him, as a mark of their gratitude and veneration for his gallant services.

RODOMONTADE, *n. s.* Fr. *rodomontade*. From a boastful boisterous hero of Ariosto, called Rodomonte. An empty noisy bluster or boast: a rant.

The libertines of painting have no other model but a *rodomontade* genius, and very irregular, which violently hurries them away. *Dryden's Dufresnoy.*

He talks extravagantly in his passion, but, if I would quote a hundred passages in Ben Jonson's Cethegus, I could shew that the *rodomontades* of Almanzor are neither so irrational nor impossible, for Cethegus threatens to destroy nature. *Dryden.*

He only serves to be sport for his company; for in these gamesome days men will give him hints, which may put him upon his *rodomontades*.

*Government of the Tongue.*

ROE, *n. s.* Sax. *ra, ra-beorn*; Goth. and Swed. *ra*. A species of deer.

They were as swift as the roes upon the mountains. *1 Chronicles.*

Run like a roe or hart upon  
The lofty hills of Bitheron. *Sandys.*

He would him make  
The roe bucks in their flight to overtake. *Spenser.*  
Thy greyhounds are fleetier than the roe. *Shakespeare.*

Procure me a Troglodyte footman, who can catch  
a roe at his full speed. *Arbutnot and Pope.*

ROE, *n. s.* Properly roan or rone; Dan. *rann*,  
*ravn*; Teut. *rogen*. The eggs of fish.

Here comes Romeo  
Without his roe, like a dried herring. *Shakespeare.*

ROE, the seed or spawn of fish. That of the male fishes is usually distinguished by the name

of soft roe, or milt; and that of the female, hard roe, or spawn. So inconceivably numerous are these ovula, or small eggs, that M. Petit found 342,144 of them in a carp of eighteen inches; but M. Leuwenhoeck found in a carp no more than 211,629. This last gentleman observes that there are four times this number in a cod; and that a common one contains 9,344,000 eggs.

ROE, in zoology. See CERVUS.

ROE (sir Thomas), an able statesman and ambassador, born at Low Leyton, in Essex, about 1580. He was admitted into Magdalen College, Oxford, in 1593. After studying at the inns of court, and travelling to France, he was made esquire to queen Elizabeth. In 1604 he was knighted by king James I. and soon after sent to make discoveries in America. In 1614 he was sent ambassador to the great mogul, at whose court he continued four years. In 1620 he was chosen M. P. for Cirencester, and in 1621 sent ambassador to the grand signior: in which post he continued under Osman, Mustapha I., and Amurath IV. Of the transactions there he sent a true and faithful relation to the king and prince Henry; which was printed at London in 1622, in 4to. He also wrote a curious account of his transactions at the Porte, which remained in MS. till 1740; when it was published under the title of the Negotiations of sir Thomas Roe, in his Embassy to the Ottoman Porte; from 1621 to 1628, in folio. He also made a large collection of Greek and oriental MSS. which he presented to the Bodleian Library. He brought over the fine Alexandrian MS. of the Greek Bible, as a present to Charles I. from Cyril, patriarch of Constantinople; since transcribed and published by Dr. Grabe. In 1620 he was sent to mediate a peace between the kings of Poland and Sweden. This he effected, and acquired such credit with Gustavus Adolphus, that, after the victory of Leipsic, the king sent him a present of £2000. In 1640 he was chosen M. P. for the university of Oxford. In 1641 he was sent ambassador to Ratisbon; and on his return was made chancellor of the garter, and a privy-counsellor. He died in November 1644.

ROEBUCK (John), M.D., was born at Sheffield in Yorkshire, in the year 1718. After the usual course of the grammar school at Sheffield, his parents being dissenters, they placed their son under the tuition of Dr. Doddridge, then master of an academy at Northampton. He was next sent to the university of Edinburgh, where he studied medicine and chemistry; and he afterwards spent some time at the university of Leyden; at which last place he obtained a degree in medicine, in 1743. He left Leyden, after having visited some parts of the north of Germany about the end of 1744. Soon after his return, he settled as a physician at Birmingham, where he met with great encouragement. Strongly attached to chemistry, he fitted up a small laboratory in his own house, in which he spent every spare moment of his time. His first discoveries were certain improved methods of refining gold and silver, and particularly an ingenious mode of collecting the smaller particles of these precious metals, which had been formerly lost in the practical operations of many of

the manufactures. By other chemical processes, carried on about the same time in his little laboratory, he discovered also improved methods of making sublimate, hartshorn, and sundry other articles of equal importance. In order to render these employments useful to himself and the public, he chose his associate Mr. Samuel Garbet of Birmingham. They erected an extensive laboratory at Birmingham, for the purposes above mentioned; which was productive of many advantages to the manufactures of that place, and of much emolument to themselves. In 1747 the doctor married Miss Ann Roe of Sheffield. In 1749 Messrs. Roebuck and Garbet established a manufacture of oil of vitriol at Prestonpans: and, by conducting their operations with secrecy, they were enabled to preserve the advantages of their ingenuity and industry for a long period of years; and not only served the public at a much cheaper rate than had ever been done formerly, but realised in that manufacture a greater annual profit from a smaller capital than had been done in any similar undertaking. Dr. Roebuck next projected the establishment of cast iron works on an extensive and improved plan; and under his direction, with the assistance of Mr. Smeaton, and Mr. James Watt, the magnificent works at Carron were finished in the end of 1759. For some time after the establishment of the Carron works Dr. Roebuck continued to give his attention and assistance in the general management and superintendance of them; but, when the business sunk by degrees into a matter of ordinary detail, he was unfortunately induced to become lessee of the duke of Hamilton's extensive coal and salt works at Borrowstounness. The coal there was represented to exist in great abundance, and to be of superior quality; but the perpetual succession of difficulties and obstacles, which occurred in the working and raising of the coal, was such as has been seldom experienced in any work of that kind. The result was that, after many years of labor and industry, there were sunk in the coal and salt at Borrowstounness, not only his own, and the considerable fortune brought him by his wife, but the regular profits of his more successful works; together with sums of money borrowed from his relations and friends, which he was never able to repay. He died on the 17th of July, 1794. Dr. Roebuck left behind him many works, but few writings. A comparison of the Heat of London and Edinburgh, read in the Royal Society of London, June 29th, 1775; Experiments on Ignited Bodies, read there 16th of February 1776; Observations on the Ripening and Filling of Corn, read in the Royal Society of Edinburgh, 5th of June, 1784,—are all the writings of his, two political pamphlets excepted, which have been published.

ROELLA, in botany, a genus of the monogynia order and pentandria class of plants; natural order twenty-ninth, campanacæ: cor. funnel-shaped, with its bottom shut up by stamiferous valvules: stigma bifid: caps. bilocular, and cylindrical inferior.

ROEMER (Olaus), a celebrated Danish astronomer and mathematician, born at Arhusen in Jutland, 1644; and at eighteen years of age sent to the University of Copenhagen. He studied

mathematics and astronomy, and became so expert in those sciences that when Picard was sent by Louis XIV., in 1671, to make observations in the north, he engaged him to return with him to France, and had him presented to the king, who made him tutor to the dauphin, and gave him a pension. He was joined with Picard and Cassini in making astronomical observations; and in 1672 he was admitted a member of the Academy of Sciences. During the ten years he resided at Paris, he gained great reputation by his discoveries: and first found out the velocity with which light moves, by the eclipses of Jupiter's satellites. In 1681 Roemer was recalled to Denmark, by Christian V., who made him professor of astronomy at Copenhagen; and chancellor of the exchequer, &c. He became counsellor of state, and burgomaster of Copenhagen under Frederick IV. He died September 19th, 1710, aged sixty-six. Horrebow, his disciple, professor of astronomy at Copenhagen, published in 4to., 1753, various observations of Roemer, with his system, under the title of *Astronomia*. He had also printed various astronomical observations, &c., in several volumes of the *Memoirs of the Royal Academy of Sciences at Paris*, 1666.

**ROER, or RUHR.** There are two rivers of this name in the west of the Prussian states; the one flowing through the provinces of the Lower Rhine, and Cleves, and Berg, passes by Duren and Juliers, and falls into the Maese. The other, rising near Winterburg in Westphalia, flows westward, till it joins the Rhine between Ruhrort and Duisburg. It is navigable by means of sluices, but rapid and frequently overflows its banks.

**ROGA**, in antiquity, a present which the emperors made to the senators, magistrates, and even to the people; and the popes and patriarchs to their clergy. These rogæ were distributed by the emperors on the first day of the year, on their birth day, or on the natalis dies of the cities; and by the popes and patriarchs in passion-week. Roga is also used for the common pay of the soldiers.

**ROGATIO, or ROGATION**, in the Roman jurisprudence, a demand made by the consuls or tribunes of the Roman people, when a law was proposed to be passed. Rogatio is also used for the decree itself made in consequence of the people's giving their assent to this demand; to distinguish it from a *senatus consultum*, or decree of the senate.

**ROGATION**, *n. s.* Fr. *rogation*, from Lat. *rogo*. Litany; supplication.

He perfecteth the *rogations* or litanies before in use, and addeth unto them that which the present necessity required. *Hooker.*

Supplications, with this solemnity for appeasing of God's wrath, were of the Greek church termed litanies, and *rogations* of the Latin. *Taylor.*

**ROGER OF HEXHAM**, an ancient English historian, educated in the monastery of Hexham in Northumberland. He was elected prior of it about 1138. He wrote a history of the campaign of the Scottish army, under David I.,

king of Scots, when the battle of the standard was fought.

**ROGER OF HOVEDEN**, a learned man of the thirteenth century, born in Yorkshire, most probably at the town of that name, now called Howden, some time in the reign of Henry I. After he had received the first parts of education, in his native country, he studied the civil and canon law, which were then become the most lucrative branches of learning. He became domestic chaplain to Henry II., who employed him to transact several ecclesiastical affairs; in which he acquitted himself with honor. But his most celebrated work was, his *Annals of England*, from A. D. 731, when Bede's Ecclesiastical History ends, to A. D. 1202. This work, which is one of the most voluminous of our ancient histories, is more valuable for the sincerity with which it is written, and the great variety of facts which it contains, than for the beauty of its style, or the regularity of its arrangement.

**ROGERS (Charles)**, F. R. S., an eminent antiquarian, born in London, August 2d, 1711. In 1731 he obtained an office in the custom-house, and in 1747 was promoted to be clerk of the certificates. In 1752 he was admitted a member of the society of antiquaries; and soon after F. R. S. He published a most elegant and expensive work, exhibiting specimens of the manner of the different masters. This work was so much admired, that copies of it were placed in his majesty's library, and in those of the emperor of Germany, the empress of Russia, the late king of France, the British museum, &c. &c. He also published a translation of Dante's *Inferno* in 1782, 4to.; and several curious papers. He died January 2d, 1784.

**ROGERS (John)**, D. D. an eminent English divine, born in 1679, at Ensham, in Oxfordshire, where his father was vicar. He was educated at Oxford, and in 1693 was admitted of Corpus Christi College, and became fellow in 1706. In 1710 he became B. D., and in 1716 rector of Wrington; when he married Miss L. Hare, sister of lord Coleraine. In 1719 he engaged in the Bangorian controversy; and published *A Discourse on the Visible and Invisible Church of Christ*; in 8vo. Dr. Sykes having published an answer, he replied in a *Review of the Discourse*. He gained so much credit by these works that the university of Oxford conferred on him by diploma the degree of D. D. In 1726 he was made chaplain to the prince of Wales, afterwards George II; when he published *A Defence of Christianity against Collins's Scheme of Literal Prophecy*. In October 1728 he was made vicar of St. Giles's in London: but died 1st of May, 1729.

**ROGGERVELDT, UPPER, MIDDLE, AND LITTLE**, three districts in the north part of the colony of the Cape of Good Hope, occupying a table land formed at the summit of the great range of mountains from which it derives its name. It contains the largest and best breed of horses in the colony; but the temperature is cold, so that the inhabitants are under the necessity of coming down for four months to the foot of the mountains. See **CAPE OF GOOD HOPE**.

ROGUE, *n. s. & v. n.* } 'Of uncertain ety-  
 RO'GUERY, *n. s.* } mology,' says John-  
 ROGUESHIP, } son. Qu. Lat. *arrogatio*?  
 RO'GUISH, *adj.* } A wandering beggar;  
 RO'GUISHLY, *adv.* } a vagrant; a dishonest  
 RO'GUISHNESS, *n. s.* } person; a name of  
 slight tenderness: to play the rogue: the other  
 derivatives corresponding.

For fear lest we, like rogues, should be reputed,  
 And for ear-marked beasts abroad be bruted.

*Spenser.*  
 If he be but once so taken idly *roguing*, he may  
 punish him with the stocks. *Id. on Ireland.*

Though the persons, by whom it is used, be of  
 better note than the former *roguish* sort; yet the  
 fault is no less worthy of a marshal. *Spenser.*

Thou killest me like a *rogue* and a villain. *Shakspeare.*

I never knew a woman love man so.  
 —Alas, poor *rogue*, I think indeed she loves. *Id.*  
 You *rogue*, here's lime in this sack too; there's  
 nothing but *rogue*ry to be found in villainous man. *Id.*

The scum of people and wicked condemned men  
 spoiled the plantation; for they will ever live like  
*rogues*, and not fall to work, but be lazy and do mis-  
 chief. *Bacon's Essays.*

To live in one land is captivity,  
 To run all countries wild a *rogue*ry. *Donne.*  
 He *rogued* away at last, and was lost. *Carew.*  
 Like the devil did tempt and sway 'em  
 To *rogue*ries, and then betray 'em. *Hudibras.*  
 If he call *rogue* and rascal from the garret,  
 He means you no more mischief than a parrot. *Dryden.*

Say, in what nasty cellar under ground,  
 Or what church porch your *rogueship* may be found? *Id.*

The most bewitching leer with her eyes, the most  
*roguish* cast; her cheeks are dimpled when she smiles,  
 and her smiles would tempt an hermit.

*Id. Spanish Fryar.*  
 The kid smelt out the *rogue*ry. *L'Estrange.*

A *rogue* upon the highway may have as strong an  
 arm, and take off a man's head as cleverly as the  
 executioner; but then there is a vast disparity, when  
 one action is murder, and the other justice. *South.*

I am pleased to see my tenants pass away a whole  
 evening in playing their innocent tricks; our friend  
 Wimble is as merry as any of them, and shews a  
 thousand *roguish* tricks on these occasions. *Addison.*

The *rogue* and fool by fits is fair and wise,  
 And even the best, by fits, what they despise. *Pope.*

The *rogue*ry of alchymy,  
 And we, the bubbled fools,  
 Spend all our present stock in hopes of golden rules. *Swift.*

He gets a thousand thumps and kicks,  
 Yet cannot leave his *roguish* tricks. *Id.*  
 I see thee dancing o'er the green,  
 Thy waist sae jimp, thy limbs sae clean,  
 Thy tempting looks, thy *roguish* een—  
 By heaven and earth I love thee! *Burns.*

ROHAN (Peter), Chevalier de Ghie, a brave  
 Frenchman who flourished under Louis XI.,  
 who, for his valor, made him marshal of France,  
 in 1475. He was one of the four lords who go-  
 verned the kingdom during that king's illness,  
 in 1484. In 1486 he defended Picardy against  
 the archduke of Austria. He commanded the  
 vanguard at the battle of Fourmoule, in 1495;  
 and Louis XII. appointed him his prime coun-  
 sellor, and general of the army in Italy. But

all his merits were disregarded by the queen  
 Anne of Austria, who, taking umbrage at him for  
 having stopped her equipage, persecuted him  
 with the most unrelenting violence, and subject-  
 ed him by an iniquitous process to damages of  
 31,000 livres. This brave but ill-used general  
 died April 22d, 1613.

ROHAN (Henry duke of), prince of Leon, and  
 peer of France, was born at the castle of Blein,  
 in Brittany, in 1579; and gained the affection of  
 Henry IV. by his bravery at the siege of Amiens,  
 when only in his sixteenth year. After Henry's  
 death, he became the chief leader of the Protes-  
 tants in France, in defence of whose rights he  
 carried on three wars against Louis XIII. The  
 first ended to the advantage of the Protestants;  
 the second and third were occasioned by the  
 sieges of Rochelle. The duke at last procured  
 for them an honorable peace in 1629. After  
 this he retired to Venice, and that republic ap-  
 pointed him their commander-in-chief against  
 the Imperialists; but Louis XIII. recalled him,  
 and sent him ambassador to Switzerland and  
 the Grisons. After many victories he drove the  
 Spaniards and Imperialists out of the Valteline,  
 in 1633; and defeated the former again at Lake  
 Koma, in 1636. In 1637 he concluded a treaty  
 with the Grisons: but afterwards, joining the  
 duke of Saxe Weimar against the Imperialists,  
 he was wounded at the battle of Rhinfeld, Febru-  
 ary 28th 1638; and died 13th of April, aged  
 fifty-nine. Though so much engaged in wars,  
 he wrote several treatises: as 1. The Interests of  
 Princes: Cologne, 1660, 12mo. 2. The Perfect  
 General; 12mo. 3. On the Corruption of the  
 Ancient Militia. 4. On the Government of the  
 thirteen Provinces. 5. Memoirs containing the  
 history of France, from 1610 to 1629. 6. Poli-  
 tical Discourses on State affairs, from 1612 to  
 1629, 8vo. Paris, 1644. 7. Memoirs and Let-  
 ters on the War of the Valteline, in 3 vols. 12mo.  
 Geneva, 1759.

ROHAULT (James), a celebrated Cartesian,  
 the son of a merchant of Amiens, where he was  
 born in 1620. He became well skilled in the  
 mathematics, and taught them at Paris where he  
 became acquainted with M. Clerselier, an advo-  
 cate, whose daughter he married. He taught  
 philosophy in the same city with uncommon ap-  
 plause. He died in Paris in 1675. He wrote  
 in French, 1. A Treatise on Natural Philosophy,  
 2. The Elements of the Mathematics. 3. A  
 Treatise on Mechanics, which is very curious.  
 4. Philosophical Conversations; and other works.  
 His Physics were translated into Latin, by Dr.  
 Samuel Clarke, with notes, in which the Carte-  
 sian errors are corrected upon the Newtonian sys-  
 tem.

ROHILCUND, or RAHILKHAND, in Sanscrit  
 Kuttair, is a tract of Hindostan situated east of  
 the Ganges, between 28° and 30° N. lat., and  
 78° to 80° E. long. Commencing in the vicini-  
 ty of the Loldong Pass, at the foot of the Ke-  
 maon Hills, it extends south-eastward to the  
 town of Pillibet. On the north it is bounded  
 by the Sewalic and Kemaon Hills, and on the  
 south by the dominions of Oude, the principal  
 rivers being the Ganges and Ramgunga: the  
 latter traverses Rohilcund nearly in its whole ex-

tent, and joins the Ganges at Kanoge. On the eastern side the Dewah, or Goggra, issues from the Kemaon Mountains, and runs past the town of Pillibet, where, during the height of the rains, the timber of the adjacent forests is embarked for Patna, Calcutta, and other large towns. There are many smaller streams which contribute to its fertility, being distributed by means of canals and reservoirs; water is also found by digging a few feet. Rohilcund is calculated to be one of the richest natural districts of the East; and was, when ceded to the British by the nabob of Oude, in 1801, one of the most desolate regions in Hindostan. The chief articles raised are grain of all sorts, sugar-cane, indigo, cotton, and tobacco.

In the early periods of the Mogul empire Rohilcund contained the cities of Shahabad, Shahjeanpoor, Bareilly, Bissowlee, Budayoon, Owlah, Moradabad, and Sumbul: which last communicated its name to a great part of the district. During the existence of the Patan dynasty, many princes of that family kept their court, for a series of years, in Budayoon, where, as in many other parts of Rohilcund, are still to be seen the remains of magnificent edifices and mausoleums. The Rohillahs were originally an Afghaan or Patan race, who emigrated from the province of Cabul. About 1720 the Afghaan chiefs, Bisharut Khan and Daood Khan, accompanied by a band of their countrymen, came to Hindostan in quest of military service. They were first entertained by Madhoo Sah, the zemindar of Serowly, who maintained, by predatory incursions, a large party of banditti. While plundering an adjacent village, Daood Khan captured a youth of the Jaut tribe, whom he converted to the Mahomedan religion, named Ali Mahomed, and adopted. Daood Khan was succeeded as principal leader of the Rohillahs by this youth, who, in consequence of the distracted state of Hindostan, soon established his power over this territory. He died in 1748, and left six sons; but was succeeded in the chieftainship by Hafez Rehmut. In 1774 the combined forces of the Rohillahs were totally defeated by the British army at the battle of Cutterah, where Hafez Rehmut was slain, and with this event terminated the Rohil- lah sway.

ROIST, *v. n.* } Goth. *rosta*; Goth. and Swed.  
RO'STER, *n. s.* } *raust*. Of this word the most probable etymology, says Dr. Johnson, is from Isl. *ristar*, a violent man. To behave turbulently; to act at discretion; to be at free quarter; to bluster: vociferation. Thomson.

I have a *roisting* challenge sent amongst  
The dull and factious nobles of the Greeks,  
Will strike amazement to their drowy spirits.

*Shakspeare.*

Among a crew of *roist'ring* fellows,  
He'd sit whole evenings at the alehouse. *Swift.*

ROLAND (M.), one of the celebrated founders of the French Revolution, was born in 1732, at Le Clos de la Platiere, twelve miles from Villefranche. His family was ancient and noble. He was educated for the church; but, not choosing the clerical profession, he went to Rouen, where his relation M. Godinot was inspector of manufactures, and proposed to him to

Vol. XVIII.

follow this branch of administration. He agreed and soon was distinguished for activity, industry, and disinterestedness. Government soon gave him a higher office, with an income which satisfied his wishes. While in Italy, he wrote letters to Madame Phlepon, afterwards his wife, by the medium of his brother, a Benedictine prior, containing Observations on the Men, Manners, and Manufactures of Italy, which were afterwards published. He was soon after entrusted with a considerable part of the Encyclopædia. At the commencement of the revolution M. Roland was appointed inspector for Lyons: he was a member of all the academies in the south of France; and had drawn up the Cahiers of Lyons, on the convocation of the states general, at the express desire of the society of agriculture. After faithfully discharging the duties of his mission, he returned to his native province. Returning some time after to Paris, he became intimate with the celebrated Brissot, who introduced him to the Jacobin club. He was soon nominated a member of the committee of correspondence. Much jealousy had been excited about this time by the suspicious conduct of the court; and, some of the Girondists being consulted about the formation of a patriotic administration, Roland was pointed out by the committee of the Place Vendome as a man every way qualified; and his writings were referred to as proofs of his attachment to liberty. The king approved, and Brissot was sent to Madame Roland, to discover whether her husband would accept of the important office of minister of the Home Department. Roland accepted of the appointment; and the next day Roland appeared at court, to be presented, take the oaths, and enter on his new office; but the courtiers were astonished, to find him not in an elegant court habit, but in his ordinary dress. At length the menacing attitude assumed by the court of Vienna produced a crisis. Servan, the minister at war, proposed to the assembly the formation of a camp of 20,000 men under the walls of Paris. This scheme was adopted with enthusiasm, as well as another against the clergy. All the six ministers supported these decrees, but the king made use of the veto which the constitution had given him, and refused his assent; on which, after sending a letter to the king, Roland gave in his resignation. The constituent assembly unanimously voted that he had 'retired with the thanks and gratitude of his country.' His resignation had a prodigious effect on the minds of the public, and rendered the conduct of the court suspected. At length, on the 10th of August, the palace being taken, and the king and royal family made prisoners, citizens Roland, Claviers, and Servan, were restored to their offices, and three new ones appointed, viz. Danton to that of justice, le Bruu, to that of the foreign affairs, and Mouge to the marine. But, in September 1792, sanguinary men murdered a number of the clergy and aristocracy, without trial or form of justice. Roland and all his friends of the Girondist party disapproved of these crimes, and endeavoured to bring the murderers to justice, and thus lost their popularity. Roland's house, formerly revered as sacred, was



now treated with outrage by the mob. The barbarity and injustice of the mountain party in the convention soon afterwards arrived at its utmost pitch. On the 31st of May, 1793, Roland was denounced, with others of the Girondist party. Roland endeavoured to conceal himself, by advice of his wife; who did not suspect her danger, but she was arrested soon after, imprisoned, and guillotined. Roland on this left the asylum of a friend, who had hitherto concealed him; and, repairing to a spot on the great road leading to Rouen, he there committed suicide, leaving a paper containing the following lines:—'Whoever you may be that find me lying here, respect my remains; they are those of a man who devoted his whole life to being useful, and who died, as he lived, virtuous and honest.'

ROLAND, BRECHE DE, a remarkable fissure in the central part of the Pyrenees, above the village of Gavarnie. A wall of rocks, from 300 to 600 feet in height, extends in the form of a crescent, convexly towards France. In the middle is a breach, 300 feet wide, said, by tradition, to have been made by the famous Roland. The great mountain of Marbore rises over it like a citadel, and the elevation is so great that it has been for ages without a trace of vegetation.

ROLANDRA, in botany, a genus of the polygamia segregata order, and syngenesia class of plants; natural order forty-ninth, compositæ. COMMON CAL. consisting of distinct flosculi, between each of which are short squamæ, the whole forming a round head: PARTIAL CAL. bivalved. COR. small and funnel-shaped, the tube small as a thread, the laciniæ short and acute. The stamina are five; the style bifid. It has no other seed vessel except the partial calyx, which contains a long three-sided seed. Of this there is only one species, viz.

R. argentea; a native of the West Indies, found in copes and waste lands.

ROLL, *v. a., v. n., &* Fr. and Teut. *rolle*; ROLL'ER, *n. s.* [*n. s.*] } Arm. *roll*; Welsh *rholl*.  
 ROLLING-PIN, } To turn or move any  
 ROLLING-PRESS, } thing by application of  
 ROLL'Y-POOLY. } the different parts of  
 its surface successively to the ground; to move in a circle; form by rolling into masses; form in a stream or by a current or a course of pressure; be moved as a cylinder or circle; run or revolve; be tossed to and fro; fluctuate; be moved by violence: as a noun substantive, the act of rolling or state of being rolled; the thing rolled; a round body; mass; in particular a rolled writing or sheet of MS.; public writing; register; office: a roller is, any thing revolving on its own axis; bandage: rolling-pin, a pin on or by which paste is rolled: rolling-press, the press of copper-plate printers: roll'Y-pooly, a corruption of 'roll ball into the pool', a game. Mr. Thomson says from Fr. *rouler poulie*, to turn a pulley; or Ital. *ruollo*, a waltz.

Darius made a decree, and search was made in the house of the *rolls*, where the treasures were laid up. *Ezra* vi. 1.

Who shall *roll* us away the stone from the door of the sepulchre? *Mark* xvii. 3.

He fashioned those harmonious orbs that *roll* in restless gyres about the Arctick pole. *Sandys*.

Beasts only cannot discern beauty; and let them be in the *roll* of beasts that do not honour it. *Sidney*.

His chamber all was hanged about with *rolls*  
 And old records, from ancient times derived. *Spenser*.

Cromwell is made master  
 O' th' *rolls*, and the king's secretary. *Shakespeare*.  
 These signs have marked me extraordinary,  
 And all the courses of my life do shew,  
 I am not in the *roll* of common men. *Id.*  
 The *roll* and list of that army doth remain. *Davies*.  
 Grind red lead, or any other colour, with strong  
 wort, and so *roll* them up into long *rolls* like pencils. *Peacham*.

Of that short *roll* of friends writ in my heart,  
 There's none that sometimes greet us not. *Donne*.  
 When a man tumbles a *roller* down a hill, the  
 man is the violent enforcer of the first motion; but,  
 when it is once tumbling, the property of the thing  
 itself continues it. *Hammond*.  
 Heaven shone and *rolled* her motions. *Milton*.

Thou, light,  
 Revisitest not these eyes, which *roll* in vain,  
 To find the piercing ray, and find no dawn. *Id.*  
 Wave *rolling* after wave in torrent rapture. *Id.*  
 Down they fell

By thousands, angel on archangel *rolled*. *Id.*  
 The *rolls* of parliament, the entry of the petitions,  
 answers, and transactions in parliament, are extant. *Hale*.

Our nation is too great to be ruined by any but it-  
 self; and, if the number and weight of it *roll* one  
 way upon the greatest changes that can happen, yet  
 England will be safe. *Temple*.

I'm pleased with my own work, Jove was not more  
 With infant nature, when his spacious hand  
 Had rounded this huge ball of earth and seas.  
 To give it the first push, and see it *roll*  
 Along the vast abyss. *Dryden*.

When thirty *rolling* years have run their race. *Id.*  
 Please thy pride, and search the herald's *roll*,  
 Where thou shalt find thy famous pedigree. *Id.*  
 In human society, every man has his *roll* and sta-  
 tion assigned him. *L'Estrange*.

The long slender worms, that breed between the  
 skin and flesh in the isle of Ormuz and in India, are  
 generally twisted out upon sticks or *rollers*. *Ray on the Creation*.

To keep ants from trees, encompass the stem four  
 fingers' breadth with a circle or *roll* of wool newly  
 plucked. *Mortimer*.

They make the string of the pole horizontal towards  
 the lathe, conveying and guiding the string from the  
 pole to the work, by throwing it over a *roller*.  
*Moxon's Mechanical Exercises*.

Reports, like snow-balls, gather still the farther  
 they *roll*. *Government of the Tongue*.

Large *rolls* of fat about his shoulders hung,  
 And from his neck the double dewlap hung. *Addison*.

Here tell me, if thou dar'st, my conscious soul,  
 What different sorrows did within thee *roll*. *Prior*.  
 Busy angels spread

The lasting *roll*, recording what we said. *Id.*  
 Let us begin some diversion; what d'ye think of  
*roul'ypooly* or a country dance? *Arbutnot*.

By this *rolling*, parts are kept from joining to-  
 gether. *Wiseman*.

Fasten not your *roller* by tying a knot, lest you  
 hurt your patient. *Wiseman's Surgery*.  
 The pin should be as thick as a *rollingpin*. *Wiseman*.

'Tis a mathematical demonstration, that these  
 twenty-four letters admit of so many changes in





RIDLEY.



ROLLIN.



REMBRANDT.



LORD RODNEY.



ROCHETOUCAULT.



ROBESPIERRE.



RICHIEU.



ST G. ROOKE.



RICHARDSON.

their order, and make such a long *roll* of differently ranged alphabets, not two of which are alike, that they could not all be exhausted, though a million millions of writers should each write above a thousand alphabets a-day, for the space of a million millions of years.

*Bentley.*

A small Euphrates through the piece is *rolled*,  
And little eagles wave their wings in gold. *Pope.*

Twice ten tempestuous nights I *rolled*, resigne.  
To roaring billows and the warring wind. *Id.*

Storms beat, and *rolls* the main;  
Oh beat those storms, and roll the seas in vain! *Id.*

In her sad breast the prince's fortunes *roll*,  
And hope and doubt alternate seize her soul. *Id.*

The eye of time beholds no name  
So blest as thine, in all the *rolls* of fame. *Id.*

Lady Charlotte, like a stroller,  
Sits mounted on the garden *roller*.

*Swift's Miscellanies.*

Listening senates hang upon thy tongue,  
Devolving through the maze of eloquence  
A *roll* of periods, sweeter than her song. *Thomson.*

**ROLL**, in law, signifies a schedule of parchment, which may be rolled up by the hand. In these schedules all the pleadings, memorials, and acts of court, are entered and filed by the proper officer; which being done, they become records of the court. Of these there are in the exchequer several kinds, as the great wardrobe roll, the cofferer's roll, the subsidy roll, &c.

**ROLL, MUSTER**, that in which are entered the soldiers of every troop, company, regiment, &c. As soon as a soldier's name is written down on the roll, he is punishable if he desert.

A **ROLL OF PARCHMENT** denotes the quantity of sixty skins. The ancients made all their books up in the form of rolls; and in Cicero's time the libraries consisted wholly of such rolls.

**ROLLS, MASTER OF THE.** See **MASTER.**

**ROLLS OFFICE**, is an office in Chancery Lane, London, appointed for the custody of the rolls and records in chancery.

**ROLLS OF PARLIAMENT** are the MS. registers or rolls of the proceedings of our ancient parliaments, which, before the invention of printing, were all engrossed on parchments, and proclaimed openly in every county. In these rolls are also contained many decisions of very difficult points of law, which were frequently in former times referred to the decision of that high court.

**ROLLE** (Michael), an eminent French mathematician, born at Auvergne, 1652. His great mathematical skill procured him a place in the Academy of Sciences, and a pension. In 1690 he published a treatise on Algebra, and died in 1719.

**ROLLI** (Paul) was born in Rome in 1687. He was the son of an architect, and a pupil of the celebrated Gravina. An intelligent English nobleman, having brought him to London, introduced him to the royal family as a master of the Tuscan language. Rolli remained in England till the death of queen Caroline his protector. He returned to Italy in 1747, where he died in 1767, in the eightieth year of his age, leaving behind him a very curious collection in natural history, &c., and a valuable and well chosen library. His principal works first appeared in London in 1735, in 8vo. They consist of odes in blank verse, elegies, songs, &c., after the man-

ner of Catullus. There is likewise a Collection of Epigrams, printed at Florence in 1776, in 8vo., and preceded by his life by the abbé Fondini. There are likewise by him translations into Italian verse of Milton's Paradise Lost, London, folio, 1735; and of Anacreon's Odes, London, 1739, in 8vo.

**ROLLIN** (Charles), a justly celebrated French writer, was the son of a cutler in Paris, and was born in 1661. He studied in the college Du Plessis, in which he obtained a bursary, through the interest of a Benedictine monk of the White Mantle, whom he had served at table. After having studied humanity and philosophy at this college, he applied to divinity three years at the Sorbonne; but he did not prosecute this study, and never rose in the church higher than to the rank of a priest. He afterwards became professor of rhetoric in the same college; and in 1688 succeeded Horson, his master, as professor of eloquence, in the royal college. In 1694 he was chosen rector, and continued in that office two years. By virtue of his office he delivered the annual panegyric upon Louis XIV. He made many very useful regulations in the university; and particularly revived the study of the Greek language, which had been much neglected. He substituted academical exercises in the place of tragedies. Upon the expiration of the rectorship, cardinal Noailles engaged him to superintend the studies of his nephews, who were in the college of Laon; and in this office he was employed, when, in 1699, he was with great reluctance made coadjutor to the principal of the college of Beauvais. This college was then a kind of desert, with very few students, and without any manner of discipline: but Rollin's great reputation and industry soon re-peopled it, and made it a flourishing society. In this situation he continued till 1712; when, the controversy between the Jesuits and the Jansenists drawing towards a crisis, he fell a sacrifice to the prevalence of the former. Father le Tellier, the king's confessor, a furious agent of the Jesuits, infused into his master prejudices against Rollin, whose connexions with cardinal de Noailles would alone have sufficed to have made him a Jansenist; and on this account he lost his share in the principality of Beauvais. His edition of Quintilian with his own notes appeared in 1715, in 2 vols. 12mo., with an elegant preface, setting forth his method and views. In 1710 the university of Paris chose Rollin again Rector: but he was displaced in about two months by a lettre de cachet. The university had presented to the parliament a petition, in which it protested against taking any part in the adjustment of the late disputes; and their being congratulated in a public oration by Rollin, on this step, occasioned the letter which ordered them to choose a rector of more moderation. He now composed his treatise upon the Manner of Studying and Teaching the Belles Lettres, which was published in 2 vols. in 1726, and two more in 1728, 8vo. The work was exceedingly successful, and its success encouraged its author to undertake his *Histoire Ancienne*, &c., or Ancient History of the Egyptians, Carthaginians, Assyrians, Babylonians, Medes and Persians, Macedonians and Greeks, which he finished in 13 vols

Évo., and published between 1730 and 1738. Rollin was one of the most zealous adherents of deacon Pâris; and, before the enclosure of the cemetery of St. Medard, this distinguished character might have been often seen praying at the foot of his tomb. This he confesses in his Letters. He published also lesser pieces; containing different Letters; Latin Harangues, Discourses, Complimentary Addresses, &c., Paris 1771, 2 vols. 12mo. He died in 1741.

**ROLLING**, the motion by which a ship rocks from side to side like a cradle, occasioned by the agitation of the waves. Rolling, therefore, is a sort of revolution about an imaginary axis passing through the centre of gravity of a ship: so that the nearer the centre of gravity is to the keel the more violent will be the rolling motion; because the centre about which the vibrations are made is placed so low in the bottom that the resistance made by the keel, to the volume of water which it displaces in rolling, bears very little proportion to the force of the vibration above the centre of gravity, the radius of which extends as high as the mast heads. But, if the centre of gravity is placed higher above the keel, the radius of vibration will not only be diminished, but an additional force to oppose the motion of rolling will be communicated to that part of the ship's bottom which is below the centre of gravity. It may, however, be necessary to remark that the construction of the ship's bottom may also contribute to diminish this movement considerably. Many fatal disasters have happened to ships arising from violent rolling.

**ROLLING**, in gardening and husbandry, the operation of drawing a roller over the surface of the ground, with the view of breaking down the clods, rendering it more compact, and bringing it even and level. This is a practice that becomes necessary both upon the tillage and grasslands, and which is of much utility in both sorts of husbandry. In the former case, it is made use of with different intentions, as for the purpose of breaking down and reducing the cloddy and lumpy parts of the soil in preparing it for the reception of crops. It is also of great use in many cases of light soils, in rendering the surface more firm, even, and solid, after the seed is put in. It is likewise found beneficial to young crops in spring, in various instances. It is said, by the author of Practical Agriculture, that in the cases of stiff, heavy, and adhesive soils of different kinds, it may frequently be made use of with the first-mentioned intention with very great advantage; but it should only be employed when such lands are tolerably dry, for, when drawn over the ground under the contrary circumstances, little benefit can be afforded in the way of pulverisation, while much mischief must be produced by the poaching of the horses, and the plastering the earth round the implement. But, by using it in the manner just directed, all the lumpy or cloddy parts of the surface soil may be effectually crushed and reduced into a fine powdery state, fit for the reception of the seed. It is likewise supposed that, in cases where lands have been left rough after ploughing, for the purpose of more effectually destroying weeds, it may be of utility, by being

employed before the harrows, to give them more power in laying hold of and reducing the soil, and by the pulverisation that it affords, and the more perfect retention of moisture that it causes, in consequence of the surface being rendered more close and compact, the seed-weeds are produced more abundantly, and more readily destroyed. It is likewise in these last methods, says Mr. Donaldson, that it proves so highly beneficial in all cases where grass-seeds are sown; as well as by the equality and smoothness of surface that are thereby produced; and it is well observed, by the same writer, that if no other benefit were derived from rolling lands in tillage than smoothing the surface, even that in harvest is of material consequence, more especially where the crops are cut down with the scythe, which is general in most of the southern districts of the kingdom, and which the increasing scarcity of laborers must soon, in all probability, introduce into those of the north. See **RURAL ECONOMY**.

**ROLLING TACKLE**, a pulley or purchase fastened to that part of a sail-yard which is to the windward of the mast, in order to confine the yard close down to the leeward when the sail is furled: it is used to prevent the yard from having too great a friction against the mast in a high sea, which would be equally pernicious to both.

**ROLLIUS** (Reinhold Henry), a learned German philologist, who, in 1779, published a very useful work, entitled *The Lives of the Philosophers, Orators, Poets, Historians, and Philologers*.

**ROLLO**, the conqueror of Normandy, was a Norwegian duke, banished from his country by Harold Harfager, who conquered Norway in 870, on account of his piracies. He first retired with his fleet among the islands of the Hebrides to the north-west of Scotland, whither the flower of the Norwegian nobility had fled for refuge when Harold had become master of the kingdom. He was there received with open arms by those warriors, who, eager for conquest and revenge, waited only for a chief to lead them on. Rollo, setting himself at their head, sailed towards England, which had been long a field open to the violence of the northern nations. But the great Alfred had some years before established such order, in this part of the island, that Rollo, after several fruitless attempts, despaired of forming there such a settlement as should make him amends for the loss of his own country. He pretended therefore to have had a supernatural dream, which promised him a glorious fortune in France, and which served at least to support the ardor of his followers. The weakness of the government in that kingdom, and the confusion in which it was involved, were still more persuasive reasons. Having therefore sailed up the Seine to Rouen, he immediately took the capital of that province, then called Neustria, and making it his magazine of arms, he advanced up to Paris, to which he laid siege in form. This war at length ended in the entire cession of Neustria, which Charles the Simple was obliged to give up to Rollo and his Normans, to purchase a peace. Rollo received it in perpetuity to himself and his

posterity, as a feudal duchy dependent on the crown of France. The interview between Charles and this new duke gives a curious picture of these Normans; for Rollo would not take the oath of fealty to his sovereign lord any other way than by placing his hands within those of the king, and absolutely refused to kiss his feet, as custom then required. It was with great difficulty he was prevailed on to let one of his warriors perform this ceremony in his stead; but the officer to whom Rollo deputed this service suddenly raised the king's foot so high that he overturned him on his back: a piece of rudeness which was only laughed at, to such a degree were the Normans feared and Charles despised. Soon after Rollo was persuaded to embrace Christianity, and was baptised by the archbishop of Rouen in the cathedral. See **NORMANDY**.

**ROLLOCK** (Robert), the first principal of the college of Edinburgh, was the son of David Rollock of Powis, near Stirling. He was born in 1555. He was sent to St. Andrews, and admitted a student in St. Salvator's College. His progress in the sciences was so rapid that he had no sooner taken his degree of M. A. than he was chosen a professor of philosophy, and read lectures in St. Salvator's College. The magistrates of Edinburgh, on the erection of the university in that city, in 1582, made choice of Mr. Rollock to be principal and professor of divinity. In 1593 principal Rollock and others were appointed, by the states of parliament, to confer with the popish lords. In 1595 he was nominated one of the commissioners for the visitation of colleges; to enquire into the doctrine and life of the masters, the discipline used by them, the state of their rents, &c., and to report to the next assembly. In 1597 he was chosen moderator of the general assembly—the highest dignity in the Scottish church: and he had the influence to get some great abuses redressed. Being one of fourteen ministers appointed to take care of the affairs of the church, he procured an act of the legislature, restoring to the prelates their seats in parliament. He had to reconcile to this measure, not only such ministers as abhorred all kinds of subordination in the church, but likewise many of the lay lords, who were not fond of such associates in parliament. He died in Edinburgh on the 28th of February, 1598, aged forty-three. His works are, 1. A Commentary on the first Book of Beza's Questions. 2. Another on the Epistle to the Ephesians, 4to., Edinburgh, 1598. 3. A third on Daniel, 4to., Edinburgh, 1591. 4. Analysis of St. Paul's Epistle to the Romans, 8vo., Edinburgh, 1594. 5. Questions and Answers concerning the Covenant of Grace and the Sacraments, 8vo., Edinburgh, 1599. 6. A Treatise on Effectual Calling, 8vo., Edinburgh, 1597. 7. A Commentary on the Epistles to the Thessalonians and Philemon, 8vo., Geneva, 1597. 8. A Commentary on fifteen select Psalms, 8vo., Geneva, 1598. 9. A Commentary on the Gos-

pel of St. John, with a Harmony of the Four Evangelists upon the Death, Resurrection, and Ascension of Jesus Christ, &c., Geneva, 1590. 10. Sermons on Several Places of St. Paul's Epistles, 8vo., Edinburgh, 1598. 11. A Commentary on the Epistle to the Colossians, 8vo., Geneva, 1602. 12. Analysis of the Epistle to the Hebrews, 8vo., Edinburgh, 1605. 13. Analysis of the Epistle to the Galatians, 8vo., London, 1602. 14. A Commentary upon the First Two Chapters of the First Epistle of Peter, 8vo., London 1603. 15 and 16. A Treatise on Justification, and another on Excommunication, both in 8vo., London, 1604. All these works, except the sermons, are in Latin.

**ROLLRICH**, or **ROLLRICH STONES**, an ancient monument in Oxfordshire, in the parish of Chipping Norton, near Long Compton, supposed to be the remains of a British temple.

**ROLPAH**, a town of Hindostan, capital of a district of the same name, in the province of Nepaul. Little more is known about it than that it is situated in the mountains, in a woody country, and governed by a chief who pays an annual tribute to the Nepaul rajah. Long. 82° 5' E., lat 29° 22' N.

**ROM'AGE**, *n. s.* Fr. *rasnage*, or Goth. *romo*; Swed. *rom*. A tumult; a bustle; a tumultuous search; clamor. Commonly written **RUMMAGE**, which see.

This is the main motive  
Of this post haste, and *romage* in the land.

*Shakspeare.*

**ROMAGNA**, the former name of a province of the states of the church, bounded by the Adriatic, the duchy of Urbino, Bologna, and the Ferrarese. It is about forty-five miles in length and thirty in breadth, and fertile in corn, wine, olives, and silk. Its pastures are also good in certain parts, and in others there are minerals. The capital is Ravenna.

**ROMAINE** (Rev. William), a popular English divine, born at Hartlepool, in Durham, in 1714; and educated first at Hertford College, Oxford, and afterwards at Christ-church, where he made himself master of the Hebrew, and became a zealous Hutchinsonian. He was ordained in 1737, and in 1738 attacked bishop Warburton's Divine Legation of Moses. In 1738 he preached a sermon before the university against the bishop's doctrine. In 1739 he was chosen lecturer of St. Dunstan's West, and in 1740 preached at St. George's. He was now become so popular that the churches were crowded. He was next appointed professor of astronomy at Gresham College, but soon resigned it. In 1764 he was elected rector of St. Andrew's, and St. Anne's, Blackfriars. He died in 1765, with the character of a powerful preacher. His works, consisting of sermons and practical tracts, were published in 8 vols. 8vo., 1766. He also published Calasio's Hebrew Concordance, in 4 vols. folio, 1743.

## ROMAN CATHOLICISM.

**ROMAN CATHOLICISM.** By the church of Rome, as distinguished from Christian churches of other denominations and communions, is meant that great body of professed Christians who, united to the bishop and see of Rome, 'ground their faith upon the authority of the church, as on a rule of faith, sure and unerring.' Popery, Papal superstition, Papists, and Romanists, are among the various appellations that have been given, in different ages, to the system of this society and its members, who commonly view them as terms of reproach. *Catholics*, or *Roman Catholic Christians*, is the only name by which they designate themselves; but the members of other communions cannot recognise their claim to the first of these; and Roman Catholics is now that by which they are designated among us, in law and parliament. We therefore adopt it as at once fair to other parties and to themselves inoffensive.

### PART I.

#### HISTORY OF THE CHURCH OF ROME.

That the church of Rome is, in regard to her descent, apostolical, and was, for some centuries, a *pure* as well as a *true* church, Protestants readily admit; but that she was either the mother or mistress of all churches, or that she was, at any time, the *only true* church, they deny. In the following historical view of the Roman Catholic church we shall consider it in its three different states, as it subsisted and still subsists, from the period of Constantine's conversion down to the present time. The first, which may be characterised as the *period of its rise*, reaches from the establishment of the Christian religion under Constantine down to the establishment of the papal power, in 606, when pope Boniface III. assumed the title of Universal Bishop; or, 756, when Pepin, king of France, invested pope Stephen II. with the temporal dominion of Rome and the neighbouring territories, upon the ceasing of the exarchate of Ravenna. The second period embraces the interval from the close of the first down to the *Reformation*. During this time Rome maintained a supremacy and dominion over the minds and consciences of men, to which all Europe submitted with implicit obedience. The establishment and long uninterrupted continuance of this power may justly be considered as among the most extraordinary circumstances in the history of mankind. The third period refers to the *decline* of this tremendous power, which was first weakened by the Reformation, and has since been gradually yielding to the influence of the Reformed doctrines and the general diffusion of knowledge among the nations of the earth.

**I. Rise of the papal power.**—The progress of Christianity, during the lifetime of its divine founder, was confined within narrow bounds. The Holy Land was alone the scene of his labors and of his life and death; no sooner, however, had he ascended to his throne, than, in the plenitude of his divine power and grace, he sent his Holy

Spirit to qualify the apostles to be the heralds of his glorious gospel to the world. In the execution of their mission they encountered various difficulties; exposed to poverty, humiliation, persecution, they always realized the prediction of their master that they were sent 'as sheep among wolves.' The hand of power, however, could not crush them, nor the fear of death arrest their zeal; in due time the once infant church had daily added to its members, character, rank, wealth, and influence; so much so as to excite the apprehensions both of the existing priesthood and magistrates; who endeavoured to overwhelm the rising cause by most cruel persecutions—renewed at intervals, with more or less severity, during the reigns of all the Pagan emperors. It was found in vain, however, for their enemies to kindle and rekindle the flames of persecution; like the children of Israel, in the days of Pharaoh, 'the more they afflicted them the more they multiplied and grew,' until they diffused themselves through all ranks of society, and acquired such an influence, even in matters of state and government, as materially to assist or depress the various competitors for the Roman empire. The extraordinary occurrences of the life of Constantine produced an entire change in the whole of the Christian profession. Its friends were now no longer called to endure patiently the hatred of the world, to take up their cross and press after a conformity to Christ in his sufferings, and through much tribulation to enter his kingdom: so long as the Christians were persecuted by the heathen, on account of their faith and practices, they were driven to the gospel as their only source of consolation and support; but such is the depravity of human nature, that, when they long enjoyed an interval from persecution, they became worldly and even profligate in their morals and litigious in their tempers. But now that the restraint was wholly taken off by Constantine, churches endowed, and riches and honors liberally conferred on the clergy; when he authorised them to sit as judges upon the consciences and faith of others, he confirmed them in the spirit of this world,—the spirit of pride, avarice, dominion, and ambition; the indulgence of which has, in all ages, proved fatal to the purity and happiness of the professed followers of Christ. Now they began to new model the Christian church, the government of which was as far as possible arranged conformably to the government of the state. The emperor himself assumed the title of bishop, and claimed the power of regulating its external affairs; and he and his successors convened councils in which they presided, and determined all matters of discipline. The bishops corresponded to those magistrates whose jurisdiction was confined to single cities; the metropolitans to the proconsuls or presidents of provinces; the primates to the emperor's vicars, each of whom governed one of the imperial provinces. This constitution of things was an entire departure from the order of worship established, under divine direction by the

apostles of Christ in the primitive churches. In fact, scarcely any two things could be more dissimilar than was the simplicity of the gospel dispensation and the hierarchy established under Constantine the Great.

It cannot be a subject of surprise, therefore that when Christianity had thus been corrupted, the bishop of Rome began to be distinguished by a pre-eminence over the prelates. During the first two centuries, says Mosheim, the pre-eminence of the bishop of Rome was a pre-eminence of order and association, and not of power and authority; now, however, a great variety of causes contributed to establish this superiority; but chiefly that grandeur and opulence by which too many professors of Christianity form ideas of pre-eminence and dignity, and which they generally confound with the reasons of a just and legal authority. The bishop of Rome surpassed all his brethren in the magnificence and splendor of the church over which he presided; in the riches of his revenues and possessions; in the number and variety of his ministers; in his credit with the people; and in his sumptuous and splendid manner of living.

In the year 366 Liberius, bishop of Rome, died, and a violent contest arose respecting his successor. The city was divided into two factions, one of which elected Damasus to that high dignity, while the other chose Ursicinus, a deacon of the church. The party of Damasus prevailed, and got him ordained. Ursicinus, enraged that Damasus was preferred before him, set up separate meetings, and, at length, he also obtained ordination from certain obscure bishops. This occasioned great disputes among the citizens, which gave rise to a dangerous schism, and to a sort of civil war within the city of Rome, which was carried on with the utmost barbarity and fury, and produced the most cruel massacres and desolations. This inhuman contest ended in the victory of Damasus; but whether his cause was more just than that of Ursicinus is a question not so easily to be determined; neither of the two, indeed, seems to have been possessed of such principles as constitute a good Christian, much less of that exemplary virtue that should distinguish a Christian bishop. And this state of things continued to increase in progressive enormity, until it ultimately brought forth that system of spiritual tyranny which so long enslaved the greatest part of the civilised world. Notwithstanding, however, the pomp and splendor that surrounded the Roman see, it is certain that the bishops of that city had not acquired, in this century, that pre-eminence of power and jurisdiction in the church which they afterwards enjoyed. In the ecclesiastical commonwealth they were, indeed, the most eminent order of citizens; but still they were citizens as well as their brethren, and subject, like them, to the edicts and laws of the emperors. All religious causes of extraordinary importance were examined and determined either by judges appointed by the emperors or in councils assembled for that purpose; while those of inferior moment were decided in each district by its respective bishop. The ecclesiastical laws were enacted either by the emperor or by councils. None of the bishops acknowledged that they de-

rived their authority from the permission and appointment of the bishop of Rome, or that they were created bishops by the favor of the apostolic see; on the contrary, they all maintained that they were the ambassadors and ministers of Jesus Christ, and that their authority was derived from above. Several of those steps, however, by which the bishops of Rome mounted afterwards to the summit of ecclesiastical power and despotism, were laid at this period, partly by the imprudence of the emperors, partly by the craftiness of the Roman prelates themselves, and partly by the inconsiderate zeal and precipitate judgment of certain bishops. Constantine having transferred the seat of government from Rome to Byzantium, and having there built a city, called, after himself, Constantinople, employed all his efforts to augment the beauty and magnificence of the new metropolis of the world, and raised up the bishop of this new metropolis as a formidable rival to the Roman pontiff, and a bulwark which menaced a vigorous opposition to his growing authority.

It is worthy of remark that the progress of papal power and papal superstition have ever kept pace. The rites and institutions by which the Greeks, Romans, and other nations, had formerly testified their religious veneration for fictitious deities were now adopted, with some slight alterations, by Christian bishops, and professedly employed in the service of the true God. Gorgeous robes, mitres, tiaras, wax tapers, crosiers, processions, lustrations, images, gold and silver vases, and many such circumstances of pageantry, were equally to be seen in the heathen temples and in the Christian churches. No sooner had Constantine the Great abolished the superstition of his ancestors, than magnificent churches were every where erected for the Christians, which were richly adorned with pictures and images, and bore a striking resemblance to the pagan temples, both in their outward and inward form. One of the earliest corruptions of the church grew out of the reverence which now began to be paid to the memory of departed saints. Hence there arose a train of error and fraud which ended in the grossest creature worship. But it is the condition of humanity that the best things are those which seem most easy to be abused. The prayer which was preferred with increased fervency at a martyr's grave was at length addressed to the martyr himself: virtue was imputed to the remains of his body, the rags of his apparel, even to the instrument of his sufferings; relics were required as an essential part of the church furniture; it was decreed that no church should be erected unless some treasures of this kind were deposited within the altar, and so secured there that they could not be taken out without destroying it. It was made a part of the service to pray through the merits of the saints whose relics were there deposited, and the priest when he came to this passage was enjoined to kiss the altar. Thus an enormous train of different superstitions were gradually substituted in the place of true religion and genuine piety.

Perhaps, however, this odious revolution was owing to a variety of causes. A ridiculous precipitation in receiving new opinions, a preposter



our desire of imitating the pagan rites, and of blending them with the Christian worship, and that idle propensity which the generality of mankind have towards a gaudy and ostentatious religion, all contributed to establish the reign of superstition upon the ruins of Christianity. Accordingly, frequent pilgrimages were undertaken to Palestine as well as to the tombs of the martyrs, as if there alone the sacred principles of virtue and the certain hopes of salvation were to be acquired. The reins being once let loose to superstition, absurd notions and idle ceremonies multiplied every day. Quantities of dust and earth brought from Palestine, and other places remarkable for their supposed sanctity, were handed about as the most powerful remedies against the violence of wicked spirits, and were sold and bought every where at enormous prices. The public processions and supplications by which the pagans endeavoured to appease their gods were now adopted into the Christian worship, and celebrated with great pomp and magnificence in several places. The virtues that had formerly been ascribed to the heathen temples, to their lustrations, and to the statues of their gods and heroes, were now attributed to Christian churches, to water consecrated by certain forms of prayer, and to images of holy men. And the same privileges that the former enjoyed, under the darkness of paganism, were conferred upon the latter under the light of the gospel, or rather under that cloud of superstition that was obscuring its glory. It is true that, as yet, images were not very common; nor were there any statues at all. But it is, at the same time, as undoubtedly certain, as it is extravagant and monstrous, that the worship of the martyrs was modelled by degrees, according to the religious services that were paid to the gods before the coming of Christ. Rumors were artfully spread abroad of prodigies and miracles to be seen in certain places (a trick often practised by the heathen priests), and the design of the reports was to draw the populace in multitudes to these places, and to impose on their credulity. Nor was this all; certain tombs were falsely given out for the sepulchres of saints and confessors; the list of the saints was augmented with fictitious names, and even robbers were converted into martyrs. Some buried the bones of dead men in certain retired places, and then affirmed that they were divinely admonished by a dream that the body of some friend of God lay there. Many, especially of the monks, travelled through the different provinces, and not only sold, with the most frontless impudence, their fictitious relics, but also deceived the eyes of the multitude with evil spirits or genii.

A whole volume would be requisite to contain an enumeration of the various frauds which artful knaves practised with success to delude the ignorant, when true religion was almost entirely superseded by horrid superstition. It would also be almost endless to enter into a minute detail of all the different parts of public worship, and to point out the changes to which they were subject. The public prayers had lost much of that solemn and majestic simplicity that characterised them in the primitive times, and which

now began to degenerate into a vain and swelling bombast. The sermons, or public discourses addressed to the people, were composed according to the rules of human eloquence, and rather adapted to excite the stupid admiration of the populace who delight in vain embellishments, than to enlighten the understanding or to reform the heart. It would even seem as if all possible means had been industriously used, to give an air of folly and extravagance to the Christian assemblies; for the people were permitted, and even exhorted by the preacher himself, to crown his talents with clapping of hands and loud acclamations of applause, a recompense which was hitherto peculiar to the actors on the theatre and the orators in the forum.

A variety of circumstances at this time concurred to augment the power and authority of the Roman pontiff, though he had not yet assumed the dignity of supreme lawgiver and judge of the whole Christian church. Among all the prelates who ruled the church of Rome, during this century, there was not one who assumed the authority and pretensions of the Roman pontiff with such vigor and success as Leo, surnamed the Great. He commenced his pontificate with the most zealous exertions. In the year 445 he quarrelled with Hilary, bishop of Arles, for opposing the power of the papal see, and obtained an edict from the emperor Valentinian, which put an end to the ancient liberties of the Gallican churches, and enforced those appeals to Rome which gradually subjected all the western churches to the jurisdiction of the pretended successors of St. Peter. During the pontificate of Leo, the fourth general council was held at Chalcedon in the year 451, in which the famous canon was enacted, which rendered the see of Constantinople equal to the see of Rome in all respects, except precedence. This canon was evidently intended to check the growing power, and to oppose the daily encroachments of the bishop of Rome. Leo opposed with vehemence the passing of these decrees, and his opposition was seconded by that of many other prelates. But their efforts were vain, as the emperors threw in their weight into the balance, and thus supported the decisions of the Grecian bishops. Neither Leo nor his immediate successors were, therefore, able to overcome all the obstacles that were laid in their way, or the various checks which were given to their ambition. Many examples might be alleged in proof of this assertion, particularly the case of the Africans, whom no threats or promises could engage to submit the decision of their controversies, and the determination of their causes, to the Roman tribunal.

From this time till the close of the sixth century the history of the Roman church presents nothing worthy of notice but the increasing wickedness and superstition of its members, especially of the clergy, whose vices were now carried to the most enormous lengths; the writers of this century, whose probity and virtue render them worthy of credit, are unanimous in their accounts of the luxury, arrogance, avarice, and voluptuousness of the sacerdotal orders. If, before these times, the lustre of religion was clouded with superstition, and its divine pre-

cepts adulterated with a mixture of human inventions, this evil, instead of diminishing, increased daily. The happy souls of departed Christians were invoked by numbers, and their aid implored by assiduous and fervent prayers; while none stood up to censure or oppose so preposterous a worship. The question, how the prayers of mortals ascended to the celestial spirits (a question which afterwards produced much wrangling, and many idle fancies) did not as yet occasion any difficulty; for the Christians of this century did not imagine that the souls of the saints were so entirely confined to the celestial mansions, as to be deprived of the privilege of visiting mortals, and travelling when they pleased, through various countries. They were further of opinion that the places most frequented by departed spirits were those where the bodies they had formerly animated were interred; and this opinion, which the Christians borrowed from the Greeks and Romans, rendered the sepulchres of the saints the general rendezvous of suppliant multitudes. The images of those who, during their lives, had acquired the reputation of uncommon sanctity, were now honored with a particular worship in several places. A singular and irresistible efficacy was also attributed to the bones of martyrs, and to the figure of the cross, in defeating the attempts of Satan, removing all sorts of calamities, and in healing, not only the diseases of the body, but also those of the mind. We shall not enter here into a particular account of the public supplications, the holy pilgrimages, the superstitious services paid to departed souls, the multiplication of temples, altars, penitential garments, and a multitude of other circumstances that showed the decline of genuine piety, and the corrupt darkness that was eclipsing the lustre of primitive Christianity. Divine worship was now daily rising from one degree of pomp to another, and degenerating more and more into a gaudy spectacle; only proper to attract the stupid admiration of a gazing populace. The sacerdotal garments were embellished with a variety of ornaments, with a view to excite in the minds of the multitude a greater veneration for the sacred order. A new method also of proceeding with penitents was now introduced into the Latin church. Grievous offenders, who had formerly been obliged to confess their guilt in the face of the congregation, were now delivered from this mortifying penalty, and obtained from Leo the Great a permission to confess their crimes privately, to a priest appointed for that purpose. The external form of church government continued without any remarkable alteration during the course of this century. But the bishops of Rome and Constantinople, who were considered as the most eminent and principal rulers of the Christian church, were engaged in perpetual disputes about the extent and limits of their respective jurisdictions, and seemed both to aspire at the supreme authority in ecclesiastical matters.

In the year 588 John, bishop of Constantinople, surnamed the Faster, on account of his extraordinary abstinence and austerity, assembled, by his own authority, a council at Constantinople, to enquire into an accusation brought against

Peter, patriarch of Antioch; and upon this occasion assumed the title of œcumenical, or universal bishop. Now, although this title had been formerly enjoyed by the bishops of Constantinople, and was also susceptible of an interpretation that might have prevented its giving umbrage or offence to any, yet Pelagius, the then bishop of Rome, suspected, both from the time and the occasion of John's renewing his claim to it, that he was aiming at a supremacy over all the Christian churches; and, therefore, he opposed his claim in the most vigorous manner in letters to that purpose, addressed to the emperor, and to such persons as he judged proper to second his opposition.

To Pelagius succeeded Gregory the Great, under whose administrations missionaries were sent from Rome to Britain; of this event the following account is given:—Being one day led into the market-place of Rome with a great concourse of persons, to look at a large importation of foreign merchandise, which had just arrived, among other articles, there were some boys exposed for sale like cattle. There was nothing remarkable in this, for it was the custom every where in that age, and had been so from time immemorial; but he was struck with the appearance of the boys; their fine clear skins, the beauty of their flaxen or golden hair, and their ingenuous countenances; so that he asked from what country they came; and when he was told from the island of Britain, where the inhabitants in general were of that complexion and comeliness, he enquired if the people were Christians, and sighed for compassion at hearing that they were in a state of pagan darkness. Upon asking further to what particular nation they belonged of the many among whom that island was divided, and being told that they were Angles, he played upon the word with a compassionate and pious feeling, saying, 'well may they be so called, for they are like angels, and ought to be made coheritors with the angels in heaven.' Then demanding from what province they were brought, the answer was, 'from Deira,' and in the same humor he observed, that rightly might this also be said, for *de Dei irâ*, from the wrath of God they were to be delivered. And when he was told that their king was named Ælla, he replied, that Hallelujah ought to be sung in his dominions. This trifling sprung from serious thought, and ended in serious endeavours. From this day the conversion of the Anglo-Saxons became a favorite object with Gregory; and, when he was elected to the papacy, he took the first opportunity of beginning the good work on which he was intent. The letter written by Gregory to the emperor Maurice at Constantinople, in consequence of John, the patriarch of that city, assuming the title of universal bishop, casts so much light upon the history of that age that we shall give our readers an extract:—'Every man that has read the Gospel knows that, even by the words of our Lord, the care of the whole church is committed to St. Peter the apostle, the prince of all the apostles; and yet he is not called universal apostle, though this holy man, John, my fellow priest, labors to be called universal bishop! I am compelled to cry out, O

the corruption of times and manners! Behold the barbarians are become lords of all Europe; cities are destroyed; castles are beaten down; provinces are depopulated; there is no husbandman to till the ground. Idolaters rage and domineer over Christians; and yet priests, who ought to lie weeping upon the pavement, in sack-cloth and ashes, covet names of vanity, and glory in new and profane titles. But, far from Christians be this blasphemous name, by which all honor is taken from all other priests, while it is foolishly arrogated by one.' Gregory, with all his flattery, was unable to prevail upon the emperor Maurice to second his views; and the former, as might be expected, became not a little dissatisfied with his most religious lord. Soon after this the emperor was dethroned by one of his centurions, who first murdered him, and then usurped the crown. This wretch, whose name was Phocas, was one of the vilest of the human race, a monster, stained with those vices that serve most to blacken human nature: other tyrants had been cruel from policy;—the cruelties of Phocas are not to be accounted for, but on the hypothesis of the most diabolical and disinterested malice. He caused five of the children of the emperor Maurice to be massacred before the eyes of the unhappy father, whom he reserved to the last, that he might be a spectator of the destruction of his children before his own death.

The empress Constantine and her three daughters had taken refuge in one of the churches of the city under sanction of the patriarch of Constantinople, who defended them for a time with great spirit and resolution, not permitting them to be dragged by force from their asylum. The consequence was, that they instantly became the helpless victims of his fury, and suffered on the same spot on which the late emperor and his five sons had been recently murdered. What should we expect would be the reception which the accounts of all this series of horrid cruelty would meet with at Rome, from a man so renowned for piety, equity, and mildness of disposition as pope Gregory was? If we look into his letters of congratulation, we find them stuffed with the vilest and most venal flattery; insomuch that, were we to learn the character of Phocas only from this pontiff's letters, we should certainly conclude him to have been rather an angel than a man. 'As a subject and a Christian,' says Gibbon, 'it was the duty of Gregory to acquiesce in the established government; but the joyful applause with which he salutes the fortune of the assassin, has sullied, with indelible disgrace, the character of the saint. His object in this abject behaviour was, that he might, by means of the influence of the emperor, defeat the attempt of the patriarch to assume the title of universal bishop. This he plainly told to Leontia, the new empress, representing to her what blessings she might expect from St. Peter in heaven, provided they obliged the patriarch to relinquish the title, which the pope considered derogatory to the honor, dignity, and interests of his see. In this object he succeeded; for Phocas enacted a law by which he prohibited the bishop of Constantinople from

styling himself œcumenical, or general patriarch, declaring that this title belonged to none but the bishop of ancient Rome. Although Gregory did not himself assume the appellation of universal bishop, which, after anathematizing in his letter to the emperor, would have been too gross a violation of all decency to have been borne even in this age, yet his successor, Boniface III., did not hesitate to assume this very title; and the grant of this to Boniface's dignity by the emperor Phocas might be said to establish the ecclesiastical power of the papal see. The succeeding pontiffs used all sorts of methods to maintain and enlarge the authority and pre-eminence which they had acquired by a grant from the most odious tyrant that ever disgraced the annals of history. We find, however, in the most authentic accounts of the transactions of this century, that not only several emperors and princes, but also whole nations, opposed the ambitious views of the bishops of Rome. Besides all this, multitudes of private persons expressed publicly, and without the least hesitation, their abhorrence of the vices, and particularly of the lordly ambition, of the Roman pontiffs: and it is highly probable, that the Valdenses or Vaudois had already in this century retired into the valleys of Piedmont, that they might be more at liberty to oppose the tyranny of those imperious prelates.

Little of particular notice occurs during the seventh and eighth centuries; we may, however, cursorily observe that infallibility was first claimed by pope Agatho, in 678. In 710 the emperor Justinian, having met the pope at Nicomedia, gave to the world the first example of kissing the pontiff's foot. This act of great personal veneration became the precedent for the continued ceremony. That corruption of manners which dishonored the clergy in the former centuries, instead of diminishing in this, discovered itself under the most odious characters. The endowments of the churches and monasteries, and the revenues of the bishops, were hitherto considerable; but in this century a new and ingenious method was found out of acquiring much greater riches to the church, and of increasing its wealth through succeeding ages. An opinion prevailed universally at this time, though its authors are not known, that the punishment which the righteous Judge of the world has reserved for the transgressions of the wicked, was to be prevented and annulled, by liberal donations to God, to the saints, to the churches, and to the clergy. In consequence of this notion the great and opulent, who were generally speaking the most remarkable for their flagitious and abominable lives, offered, out of the abundance which they had received by inheritance or acquired by rapine, rich donations to departed saints, their ministers upon earth, and the keepers of the temples that were erected in their honor, in order to avoid the sufferings and penalties annexed by the priests to transgression in this life, and to escape the misery denounced against the wicked in a future state. This new and commodious method of making atonement for iniquity was the principal source of those immense treasures which from this period began

to flow in upon the clergy, the churches, and monasteries, and continued to enrich them through succeeding ages down to the present time. Emperors, kings, and princes, signalised their superstitious veneration for the clergy, by investing bishops, churches, and monasteries, in the possession of whole provinces, cities, castles, and fortresses, with all the rights of sovereignty that were annexed to them under the dominion of their former masters. Hence it came to pass that they who by their holy profession were appointed to proclaim to the world the vanity of human grandeur, and to inspire into the minds of men, by their example, a noble contempt of sublunary things, became themselves scandalous spectacles of worldly pomp, ambition, and splendor; were created dukes, counts, and marquises; judges, legislators, and sovereigns; and not only gave laws to nations, but also upon many occasions gave battle to their enemies at the head of numerous armies of their own raising.

The Roman pontiff now acted in all respects like a temporal prince, of whose enormous power history records this shocking and remarkable instance:—Charles Martel was succeeded in his office of mayor of the palace to Childeric III. by his son Pepin. In the exercise of that high office, he was possessed in reality of the royal power and authority; but, not content with this, he aspired to the titles and honors of majesty, and formed the design of dethroning his sovereign. For this purpose the states of the realm were assembled by Pepin, A. D. 751; and, though they were devoted to the interests of this ambitious usurper, they gave it as their opinion that the bishop of Rome was previously to be consulted, whether the execution of such a project was lawful or not. In consequence of this, ambassadors were sent by Pepin to Zachary, the reigning pontiff, with the following question:—‘Whether the divine law did not permit a valiant and warlike people to dethrone a pusillanimous and indolent monarch, who was incapable of discharging any of the functions of royalty, and to substitute in his place one more worthy to rule, and who had already rendered most important services to the state?’ The situation of Zachary, who stood much in need of the aid of Pepin against the Greeks and Lombards, rendered his answer such as the usurper desired; who in return conferred on Zachary the domains of Ravenna, which could not have been secured from the degraded Childeric. Thus by his spiritual authority the pope deposed a sovereign who had committed no crime; receiving from the usurper, in return, the temporal jurisdiction. When this favorable decision of the Roman oracle was published in France, the unhappy Childeric was stripped of royalty without the least opposition; and Pepin, without the smallest resistance from any quarter, stepped into the throne of his master and his sovereign. This decision was solemnly confirmed by Stephen II., the successor of Zachary, who undertook a journey into France in the year 754 in order to solicit assistance against the Lombards; and who at the same time dissolved the obligation of the oath of fidelity and allegiance which Pepin had sworn to Childeric, and

violated by his usurpation in the year 751; and, to render his title to the crown as sacred as possible, Stephen anointed and crowned him, with his wife and two sons, and, by the authority of St. Peter, forbade the French lords, on pain of excommunication, to choose a king of another race. Thus did these two ambitious men support one another in their schemes of rapacity and injustice. The criminality of the pope was indeed greatly aggravated by the pretence of religion. ‘It is you,’ said he, addressing Pepin, ‘whom God hath chosen from all eternity; for whom he did predestinate, them he also called, and whom he called them he also justified.’ This compliance of the Roman pontiffs proved an abundant source of opulence and credit to the church. When Aistulphus meditated the conquest of Rome and its territory, and formed the ambitious project of reducing all Italy under the yoke of the Lombards, the terrified pontiff, Stephen II., addressed himself to his powerful patron and protector Pepin, represented to him his deplorable condition, and implored his assistance. The French monarch embarked with zeal in the cause of the suppliant pontiff, crossed the Alps A. D. 754 with a numerous army and, having twice defeated Aistulphus, obliged him by a solemn treaty to deliver up to the see of Rome the exarchate of Ravenna, Pentapolis, and all the cities, castles, and territories, which he had seized in the Roman dukedom. Pepin then caused an instrument to be drawn up, signed by himself and his sons, by which he ceded for ever to the holy see all the places thus yielded up by the Lombard king, including the exarchate, which he had taken from the emperor of Constantinople. He afterwards caused the instruments of donation, with the keys of all the cities, to be laid on the tomb of St. Peter in Rome. Stephen thus became proprietor of the exarchate and its dependencies; and, by adding rapacity to his rebellion, was established as a temporal monarch. Thus was the sceptre added to the keys, the sovereignty to the priesthood; and thus were the popes enriched with the spoils of the Lombard kings, and of the Roman emperors. The question concerning images, which had long agitated both the eastern and western churches, was, at this time, far from being put to rest either at Rome or Constantinople, but still gave occasion to the assembling of council after council, one council annulling what the other had decreed. During the reign of the emperor Constantine Copronymus (who employed all his influence in abolishing and extirpating the worship of images) a synod was held at Constantinople, A. D. 754, to determine the controversy. The fathers being met to the number of 330, after considering the doctrine of scripture and the opinions of the fathers, decreed that every image, of whatsoever materials, made and formed by the artist, should be cast out of the Christian church as a strange and abominable thing; notwithstanding Paul I., who was at that time pope of Rome, sent a legate to Constantinople, to admonish the emperor to restore the sacred images and statues to the churches, threatening him with excommunication in case of refusal. But Copronymus treated his message with the contempt it deserved

II. *The Papal power in full exercise.*—On the decease of Paul I., A. D. 768, the papal chair was filled for a year by Constantine, who condemned the worship of images, and was, therefore, tumultuously deposed, and Stephen IV. substituted in his room, who was a furious defender of them. He immediately assembled a council in the Lateran church, where the renowned fathers abrogated all Constantine's decrees, deposed all the bishops that had been ordained by him, annulled all his baptisms and chrisms, and, as some historians relate, after having beaten and used him with great indignity, made a fire in the church and burnt him to death. After this they annulled all the decrees of the synod of Constantinople, ordered the restoration of statues and images, and anathematised that execrable and pernicious synod, giving this curious reason for the use of the images: that if it was lawful for emperors, and those who had deserved well of their country, to have their images erected, but not lawful to set up those of God, the condition of the immortal God would be worse than that of man. Thus the reign of superstition strengthened and enlarged itself until the time of Irene, the empress of Constantinople and her son Constantine, about the close of this century. Irene was the wife of Leo IV., who, in 775, after the death of Constantine, was declared emperor. Having strenuously exerted himself for the extirpation of idolatry out of the Christian church, he was poisoned by his perfidious wife, who was a zealous supporter of image worship. Under Irene's influence and authority was convened what is termed the seventh general council, held at Nice, the number of bishops present being about 350. They pronounced anathemas upon all who should not receive images, or who should apply what the Scriptures say against idols to the holy images, or who should call them idols, or who should wilfully communicate with those who rejected and despised them; adding, according to custom, 'Long live Constantine, and Irene his mother,' and anathematising all heretics, and the council that roared against venerable images. 'The holy trinity,' it said, 'hath deposed them.' Irene and Constantine approved and ratified these decrees, the result of which was, that idols and images were erected in all the churches, and those who opposed them were treated with great severity.

On the death of Pepin, king of France, in the year 768, his dominions were divided between his two sons, Charles and Carloman, the latter of whom dying two years afterwards, Charles became sole monarch of that country. In his general character he somewhat resembled our English Alfred, and is deservedly ranked amongst the most illustrious sovereigns that have appeared—a rare instance of a monarch who united his own glory with the happiness of his people.

In private life he was amiable; an affectionate father, a fond husband, and a generous friend. Though engaged in many wars, he was far from neglecting the arts of peace, the welfare of his subjects, or the cultivation of his own mind. But, with all these amiable traits in

the character of Charlemagne, a superstitious attachment to the see of Rome unhappily mingled itself, and led him to engage in theological disputes and quibbles unworthy of his character. He distinguished himself in the controversy concerning the worship of images, and sought to withdraw Adrian from an approval of the decrees of the second Nicene council. With this view he, in the year 794, assembled at Frankfort on the Main a council of 360 bishops, in order to reexamine this important question, by which the worship of images was unanimously condemned. At this period a new attack was made upon the patrimony of St. Peter. Adrian, who had succeeded Stephen in the papal chair, maintained a steady attachment to Charlemagne, which provoked Dideric, king of the Lombards, to invade the state of Ravenna, and to threaten Rome itself. Charlemagne recompensed his attachment, by marching with a large army to his succor; and having gained many considerable advantages over Dideric, and recovered the cities which he had taken, he visited the pope at Rome, confirming the grants made by his father Pepin, to which he added new donations, and formed a perpetual league of friendship between the growing power of France and the established supremacy of the western church. On this occasion he expressed his piety, by the humiliating ceremony of kissing each of the steps as he ascended to the church of St. Peter. By thus consulting the favor of the Roman pontiffs, clergy, and consequently that of the people, Charlemagne opened for himself a passage to the empire of the west and to the supreme dominion over the city of Rome and its territory, upon which the western empire seemed to depend.

In the year 796 Leo III., who had succeeded Adrian in the papacy, transmitted to Charles the Roman standard, requesting him to send some person to receive the oath of fidelity from the Romans, an instance of submission with which that monarch was highly flattered. Accordingly, in the year 800, we find Charles at Rome, where he passed six days in private conferences with the pope. On Christmas day, as the king assisted at mass in St. Peter's church in the midst of the ecclesiastical ceremonies, and upon his knees before the altar, the pope advanced, and put an imperial crown upon his head. As soon as the people perceived it, they exclaimed, 'Long life and victory to Charles Augustus, crowned by the hand of God,' 'Long live the great and pious emperor of the Romans.' The supreme pontiff then conducted him to a magnificent throne, which had been prepared for the occasion, and, as soon as he was seated, paid him those honors which his predecessors had been accustomed to pay to the Roman emperors. Leo now presented him with the imperial mantle, on being invested with which, Charles returned to his palace amidst the acclamations of the multitude. Succeeding generations, grateful for the services which Charlemagne had rendered to Christianity, canonized his memory and turned this bloody warrior into an eminent saint. In the twelfth century Frederick I., emperor of the Romans, ordered Paschal II., whom he had

raised to the pontificate, to enrol the name of this mighty conqueror among the tutelary saints of the church. Indeed Charlemagne merited this honor; for to have enriched the clergy with large and magnificent donations, and to have extended the boundaries of the church, no matter by what methods, was then considered as the highest merit, and as a sufficient pretension to the honor of saintship. But, in the esteem of those who judge of the nature and character of sanctity by the decisions of the gospel, the sainted emperor will appear utterly unworthy of that object. The favors that were conferred by the pontiff on the French monarch imperiously called for an adequate return; and it is due to Charlemagne to say that he was by no means deficient in gratitude. The Greek emperor had abdicated or forfeited his right to the exarchate of Ravenna, and the sword of Pepin, the father of Charles, had no sooner wrested it from the grasp of Aistulphus, than he conferred it on the Roman pontiff, as a recompense 'for the remission of his sins, and the salvation of his soul.' The splendid donation was granted in supreme and absolute dominion, and the world beheld a Christian bishop invested with the prerogatives of a temporal prince;—the choice of magistrates, and the exercise of justice, the imposition of taxes, and the wealth of the palace of Ravenna. 'Perhaps,' says Gibbon, 'the humility of a Christian priest should have rejected an earthly kingdom which it was not easy for him to govern without renouncing the virtues of his profession; but humility does not appear to have been a very prominent trait in the characters of the Roman pontiffs; and the profuse liberality of the French kings at this time was not much calculated to promote it among them.'

Before we narrate those events which, during the ninth and succeeding centuries, raised the papal see to its greatest height of power and arrogance, we must observe that, although hitherto the approbation of the emperor was necessary in order to the consecration of the person chosen to the pontificate, after the time of Charles the Bald, a new scene of things arose. That prince, having obtained the imperial dignity by the good offices of the bishop of Rome, returned this eminent service by delivering the succeeding pontiffs from the obligation of waiting for the consent of the emperors, in order to their being installed in their office. And thus we find that from the time of Eugenius II., who was raised to the pontificate A. D. 824, the election of the bishop of Rome was carried on without the least regard to law, order, and decency; and was generally attended with civil tumults and dissensions, until the reign of Otho the Great; who put a stop to these disorderly proceedings. Among the prelates that were raised to the pontificate in the ninth century there were very few who distinguished themselves by their learning, prudence, or virtue; or, who were studious of those particular qualities that are essential to the character of a Christian bishop. On the contrary, the greatest part of them are only known by the flagitious actions that have transmitted their names with infamy to our times; and all seem to have vied with each other in their ambitious

efforts to extend their authority, and render their dominion unlimited and universal. It is here that we may place, with propriety, an event which is said to have interrupted the much vaunted succession of regular bishops in the see of Rome, from the first foundation of that church to the present time. Between the pontificate of Leo IV., who died in the year 855, and that of Benedict III. a certain woman, who artfully disguised her sex for a considerable time, is said, by learning, genius, and dexterity, to have made good her way to the papal chair, and to have governed the church with the title and dignity of pontiff about two years. This extraordinary person is yet known by the title of Pope Joan. The period was now arrived in which the clergy aspired to the right of disposing of crowns, which they founded on the ancient Jewish practice of anointing kings. They had recourse to the most miserable fictions and sophisms to render themselves independent. They refused to take the oath of fidelity, because sacred hands could not without abomination, submit to hands impure! One usurpation led to another; abuse constituted right; a quibble appeared a divine law; ignorance sanctified every thing, and the most enormous usurpations of the clergy obtained a ready sanction from the slavish superstition of the laity.

The history of the following ages shows in a multitude of deplorable examples the disorders and calamities that sprung from the ambition of the aspiring pontiffs; it represents these despotic lords of the church laboring, by the aid of their impious frauds, to overturn its ancient government, to undermine the authority of its bishops, to engross its riches and revenues into their own hands; nay, what is still more horrible, it represents them aiming perfidious blows at the thrones of princes, and endeavouring to lessen their power and to set bounds to their dominion. The ignorance and corruption that dishonored the Christian church in this century were great beyond measure.

About the year 877 pope John VIII. convened a council at Troyes in France, one of the canons of which is sufficiently remarkable to be adduced as a specimen of the spirit of the times. It expressly asserts that 'the powers of the world shall not dare to seat themselves in the presence of the bishops unless desired.' Thus the power and influence of the pontiffs, in civil affairs, rose, in a short time, to an enormous height, through the favor and protection of the princes in whose cause they had employed the influence which superstition had given them over the minds of the people. The increase of their authority in religious matters was not less rapid or less considerable; and it arose from the same causes. The Roman pontiffs, elate with their overgrown prosperity and the daily accessions that were made to their authority, were eagerly bent upon persuading all, and had indeed the good fortune to persuade many, that the bishop of Rome was constituted, by Jesus Christ, supreme legislator and judge of the church universal; and that, therefore, the bishops derived all their authority from the Roman pontiff, nor could the councils determine any thing without

his permission and consent. After the death of Lando, who only enjoyed the dignity for a short time in the year 914, John X. obtained the pontifical chair through the intrigues of a celebrated prostitute, Theodora, with whom he had long been intimate, notwithstanding his elevated station in the church. As John was indebted for his rank and elevation in the church to the intrigues of one infamous woman so he lost his dignity and life through those of another. This was Marozia, the daughter of his former mistress Theodora. Marozia, exasperated that she did not succeed her mother in the confidence of the pope, resolved to destroy him and his brother Peter; who, at this time, was in habits of the strictest intimacy with him. She communicated the bloody design to her husband, and prevailed on him not only to approve but to be the instrument of carrying it into execution. Accordingly this wretch, on a certain day, when this pope and his brother were together in the Lateran palace, broke in at the head of a band of ruffians, killed Peter before his brother's face; and then, seizing the pope, dragged him to prison, where he soon afterwards died. This licentious pontiff was succeeded by Leo VI., who sat but seven months in the apostolic chair, which was filled after him by Stephen VII. The death of the latter, which happened in the year 931, presented to the ambition of Marozia an object worthy of its grasp; and accordingly she raised to the papal dignity John XI., who was the fruit of her lawless amours with one of the pretended successors of St. Peter, Sergius III., whose adulterous commerce with that infamous woman gave an infallible guide to the Roman church. John XI., who was thus placed at the head of the church by the credit and influence of his mother, was pulled down from this summit of spiritual grandeur, A. D. 933, by Alberic his half brother. Upon the death of Agapetus II., which happened in the year 956, Alberic II., who, to the dignity of Roman consul joined a degree of authority and opulence which nothing could resist, raised to the pontificate his son Octavian, who was yet in the early bloom of youth, and destitute of every quality that was required for discharging the duties of that high and important office. This unworthy pontiff, who assumed the name of John XII., was as unhappy as his promotion had been scandalous. Being degraded in the most ignominious manner from his high office by Otho the Great, Leo VIII. was appointed to fill his place. After this he several times conspired against the life of the new pope, and was as frequently pardoned; till at length he contrived to set himself again on the papal throne. John instantly assembled a council of prelates and cardinals, who condemned the council that had deposed him, and passed different sentences of condemnation on all those who had been accessory to the elevation of his rival. John did not long survive the holding of this council: for, having engaged in a criminal connexion with a married woman, the injured husband, who caught him in the act, put an end to the life and debaucheries of his holiness by some violent blows which he gave him on his temples.

The Roman pontiff, who before this period

had pretended to the right of creating saints by his sole authority, gave in this century the first specimen of this ghostly power—for in the preceding ages there is no example of his having exercised this privilege alone. This specimen was given in the year 993 by John XV., at a council held at the Lateran palace, who, after hearing read an account of the life and supposed miracles of Ulderic, bishop of Augusta, declared, with the approbation of his bishops, that from thenceforth Ulderic might be worshipped and invoked as a saint in heaven reigning with Christ. This is the first instance on record of the solemn canonisation of a pretendedly meritorious character, a practice which soon contributed to crowd the Roman calendar with saints, and loaded the church with wealth by the rich offerings with which the superstitious multitude were encouraged to propitiate the favor of these new mediators between God and man. The administration of John XV. was as happy as the troubled state of the Roman affairs would permit; but the tranquillity he enjoyed was not so much the effect of his wisdom and prudence as of his being a Roman by birth and a descendant from noble and illustrious ancestors.

Several learned writers have observed that, in this century, certain bishops mentioned publicly that the Roman pontiffs were not only bishops of Rome, but of the whole world; an assertion which hitherto none had ventured to make; and that even among the French clergy it had been affirmed by some that the authority of the bishops, though divine in its origin, was conveyed to them by St. Peter, the prince of the apostles. It was no doubtful mark of the progress and strength of the Christian cause that the European kings and princes began so early as this century to form the project of a holy war against the Mahometans, who were masters of Palestine; they considered it as an intolerable reproach upon Christians that the very land in which the divine author of their religion had received his birth, exercised his ministry, and made expiation for the sins of mortals, should be abandoned to the enemies of the Christian name. They also looked upon it as highly just and suitable to the majesty of the Christian religion to avenge the calamities and injuries, the persecution and reproach, which its professors had suffered under the Mahometan yoke. The bloody signal was accordingly given towards the conclusion of this century by the Roman pontiff Sylvester II., and that in the first year of his pontificate; and this signal was an epistle, written in the name of the church of Jerusalem, to the church universal throughout the world; in which the European powers are solemnly exhorted and entreated to succor and deliver the Christians in Palestine. The exhortations of the pontiff were, however, without effect, except upon the inhabitants of Pisa, who are said to have obeyed the papal summons with the utmost alacrity, and to have prepared themselves immediately for a holy campaign. The see of Rome after the death of Sylvester II., which happened in the year 1003, was filled successively by John XVII., John XVIII., Benedict VIII., and John XIX., none of whose pontificates were distinguished by any memorable

events; they were not, however, chargeable with dishonoring their high stations by that licentiousness and immorality that rendered so many of their successors infamous; their lives were virtuous; at least their conduct was decent. But their examples had little effect upon Benedict IX., a most abandoned profligate and a wretch capable of the most horrid crimes, whose flagitious conduct drew upon him the just resentment of the Romans; who, in the year 1038, degraded him from his office.

A. D. 1048 Bruno, bishop of Toul, was appointed to the pontificate. This prelate is known in the list of the popes by the name of Leo IX., and his private virtues, as well as his public acts of zeal and piety in the government of the church, were deemed meritorious enough to entitle him to a place among the saintly order. But, if we deduct from these pretended virtues his vehement zeal for augmenting the opulence and authority of the church of Rome, and his laudable severity in correcting and punishing certain enormous vices which were common among the clergy during his pontificate, there will remain little in the life and administration of this pontiff that could give him any pretensions to his distinction. Being taken prisoner by his enemies, and led captive to Benevento, dismal reflections upon his unhappy fate preyed upon his spirits, and threw him into a dangerous illness: so that after a year's imprisonment he was sent to Rome, where he concluded his days on the 19th of April 1054.

Before the pontificate of Nicholas II., A. D. 1058, the popes were chosen not only by the suffrages of the cardinals, but also by those of the whole Roman clergy, the nobility, the burgesses, and the assembly of the people. To increase the papal influence, and to limit that of the lower clergy and of the people as far as was possible, this artful and provident pontiff had a law passed by which the cardinals were empowered, upon a vacancy in the see of Rome, to elect a new pope without any prejudice to the ancient privileges of the Roman emperors in this important matter. Not that the rest of the clergy, with the burgesses, and people, were wholly excluded from all part in this election, since their consent was solemnly demanded, and also esteemed of much weight; but, in consequence of this new regulation, the cardinals acted the principal part in the creation of the new pontiff; though they suffered for a long time much opposition both from the sacerdotal order and the Roman citizens, who were constantly either reclaiming their ancient rights, or abusing the privilege they yet retained, of confirming the election of every new pope by their approbation and consent.

In the following century an end was put to all these disputes by Alexander II., who was so fortunate as to complete what Nicolas had only begun, and who transferred and confirmed to the cardinals the right of electing to the apostolic see, excluding the nobility, the people, and the rest of the clergy, from all concern in this important matter. Passing over the contentions between Henry IV. and Alexander we come to the turbulent pontificate of Hildebrand, originally a monk of the order of Clugny, who found means

to obtain a cardinal's hat. He was a man of a restless, fiery, and enterprising disposition; but chiefly remarkable for his furious zeal for the pretensions of the church. He was born at Soana, in Tuscany, of obscure parents, brought up at Rome, and had been frequently employed by that court to manage various political concerns which required dexterity and resolution; and he rendered himself famous in all parts of Italy for his zeal and intrepidity. Hildebrand had interest enough to procure himself to be elected to the pontifical chair in 1073, on the same day that Alexander was interred, by the title of Gregory VII.; and the papacy has not produced a more extraordinary character. 'All that the malice or flattery of a multitude of writers have said of this pope,' says Voltaire, 'is concentrated in a portrait drawn of him by a Neapolitan artist, in which Gregory is represented as holding a crook in one hand and a whip in the other, trampling sceptres under his feet, with St. Peter's net, and fishes on either side of him.' Gregory was installed by the people of Rome, without consulting the emperor, as had hitherto been customary. But, though Henry had not been consulted upon the occasion, Gregory prudently waited for his confirmation of the choice before he assumed the chair. He obtained it by this mark of submission: the emperor confirmed his election: and the new pontiff was not dilatory in pulling off the mask; for in a little time he raised a storm which fell with violence upon the head of Henry, and shook all the thrones in Christendom. He began his pontificate with excommunicating every ecclesiastic who should receive a benefice from a layman, and every layman by whom such benefice should be conferred. This was engaging the church in an open war with all the sovereigns of Europe. It was evident, indeed, that Gregory formed the project of making himself lord of Christendom, by at once dissolving the jurisdiction which kings and emperors had hitherto exercised over the various orders of the clergy, and by subjecting to the papal authority all temporal princes, rendering their dominions tributary to the see of Rome: and, however romantic the undertaking may appear, it was not altogether without success. The pretensions of the Romish church had at this time, says Mr. Southey, been carried to the highest pitch by Gregory VII., one of those restless spirits who obtain an opprobrious renown in history for disturbing the age in which they live. The Romanists themselves acknowledge now the inordinate ambition of this haughty pontiff, who may be deemed the founder of the papal dominion; but, during many centuries, he was held up as an object of admiration to the Christian world, and still holds his place as a saint in the Romish calendar. His sanctity, the legends of that church relate, was prefigured in childhood, by sparks proceeding from his garments and a lambent light which appeared to issue from his head. He himself affirmed that, in a dream, there went forth fire from his mouth and set the world in flames; and his enemies, who vilified him as a sorcerer, admitted that such a vision was appropriate to one who was indeed a firebrand. Another of his dreams was that he



saw St. Paul clearing out dung from his church, wherein cattle had taken shelter, and calling upon him to assist him in the work; and certain persons who were keeping vigils in St. Peter's church beheld, in a waking vision, St. Peter and Hildebrand laboring at the same task. By such artifices his reputation for sanctity was established among the people, while he obtained promotion for his activity and talents; till at length, rather by intrigue and popular outcry than by canonical election, he was chosen pope. Hitherto the popes had recognised the supremacy of the emperors, by notifying to them their election before they were consecrated, and having that ceremony performed in the presence of an imperial envoy. Hildebrand conformed to this, being conscious that his elevation was informal, and glad to have it thus ratified. The first use he made of the power which he had thus obtained was to throw off all dependence upon the temporal authority, and establish a system whereby Rome should again become the mistress of the world. A grander scheme never was devised by human ambition, and, wild as it may appear, it was at that time, in many points, so beneficial that the most upright man might conscientiously have labored to advance it. Whether the desire of benefiting mankind had any place among the early impulses of Hildebrand may be well doubted, upon the most impartial consideration of his conduct; but in preparing the way for an intolerable tyranny, and for the worst of all abuses, he began by reforming abuses and vindicating legal rights. Such a government Hildebrand would have founded; and Christendom, if his plans had been accomplished, would have become a federal body, the kings and princes of which should have bound themselves to obey the vicar of Christ, not only as their spiritual, but their temporal lord; and their disputes, instead of being decided by the sword, were to have been referred to a council of prelates annually assembled at Rome. Unhappily, the personal character of this extraordinary man counteracted the pacific part of his schemes; and he became the firebrand of Europe, instead of the peacemaker. Hitherto the princes of Christendom had enjoyed the right of nominating bishops and abbots, and of giving them investiture by the ring and crosier. The popes, on their part, had been accustomed to send legates to the emperors to entreat their assistance, to obtain their confirmation, or to desire them to come and receive papal sanction. Gregory, now resolving to push the claim of investitures, sent two of his legates to summons Henry to appear before him as a delinquent, because he still continued to bestow investitures, notwithstanding the papal decree to the contrary: adding that, if he failed to yield obedience to the church, he must expect to be excommunicated and dethroned. This arrogant message, from one whom he regarded as his vassal, greatly provoked Henry, who abruptly dismissed the legates, and lost no time in convoking an assembly of princes and dignified ecclesiastics at Worms; where, after mature deliberation they came to this conclusion: that, Gregory having usurped the chair of St. Peter by indirect means, infected the church of God with

many novelties and abuses, and deviated from his duty to his sovereign in several instances, the emperor, by the supreme authority derived from his predecessors, ought to divest him of his dignity, and appoint a successor. In the articles of accusation it was, among other things, imputed to Gregory that he was an apostate monk, an incendiary, a sacrilegist, a murderer, a liar, an abettor of adultery and incests. Henry, consequently, sent an ambassador to Rome, with a formal deprivation of Gregory: who, in his turn, convoked a council, at which were present 110 bishops, who unanimously agreed that the pope had just cause to depose Henry, to annul the oath of allegiance which the princes and states had taken in his favor, and to prohibit them from holding any correspondence with him on pain of excommunication. Hildebrand's language was, that, if kings presumed to disobey the edicts of the apostolic see, they were cut off from participating in the body and blood of Christ, and forfeited their dignities. For if that see had power to determine and judge in things celestial and spiritual, how much more in things earthly and secular! The church, he affirmed, had power to give or take away all empires, kingdoms, duchies, principalities, marquisates, countries, and possessions of all men whatsoever. A sentence of deprivation was immediately fulminated against the emperor and his adherents: 'In the name of Almighty God and by your authority,' said Gregory, addressing the members of his council, 'I prohibit Henry from governing the Teutonic kingdom and Italy; I release all Christians from their oath of allegiance to him; and I strictly forbid all persons to serve or attend him as king.' This is the first instance of a pope presuming to deprive a sovereign of his crown; but, unhappily, it was too flattering to ecclesiastical pride to be the last. Gregory well knew what consequences would result from the thunders of the church. The bishops in Germany immediately came over to his party, and drew with them many of the nobles. The Saxons took the opportunity of revolting: even the emperor's favorite Guelf, a nobleman to whom he had given the duchy of Bavaria, supported the malcontents with that very power which he owed to his sovereign's bounty; and the princes and prelates who had assisted in deposing Gregory gave up their monarch to be tried by the pope, who was requested to come to Augsburg for that purpose. To avoid the odium of this impending trial Henry submitted to the degradation of preparing to throw himself at the feet of the pontiff, to solicit absolution. It was some time before the pontiff would admit the monarch into his presence; and when the order was issued for that purpose, it was on the condition that he should enter at the outer gate of the fortress without attendants; and at the next gate he was required to divest himself of the ensigns of royalty, and put on a coarse woollen tunic, in which dress, and barefooted, he was suffered to stand for three whole days at the third gate, exposed to the severity of the weather, fasting and imploring the mercy of God and the pope. The pope from one of the windows of his castle, where he was seated with the countess Matilda,

whose close intimacy with Gregory led to too well founded suspicions of his virtue, enjoyed the exquisite pleasure of seeing an emperor in sackcloth and bareheaded at his gate. At length the persons of distinction who were with Gregory, affected at the sufferings of the king, began to complain of the severity of his holiness, which they said was more becoming a tyrant than an apostolical father or judge : these reports were carried to the pope, who, on the fourth day, admitted the king, and after much difficulty granted him absolution. That Gregory had formed the audacious plan of subjecting all the thrones of Europe to the Roman see is undoubtedly evident, both from his own epistles and also from other authentic records of antiquity. The nature of the oath he drew up for the king or emperor of the Romans, from whom he demanded a profession of subjection and allegiance, shows abundantly the arrogance of his pretensions. The despotic views of this lordly pontiff were, however, attended with less success in England than in any other country. William the Conqueror was a prince of great spirit and resolution; extremely jealous of his rights, and tenacious of the prerogatives he enjoyed as a sovereign and independent monarch; and, accordingly, when Gregory wrote him a letter demanding the arrears of the Peter-pence, and at the same time summoning him to do homage for the kingdom of England as a fief of the apostolic see, William granted the former, but refused the latter with a noble obstinacy: declaring that he held his kingdom of God only, and his own sword. Nothing was transacted in the church but by his directions: by his sole authority he banished or imprisoned the bishops whom he did not like, without waiting for a canonical sentence. He went still farther, and set himself in some measure above the popes, by forbidding his subjects to receive their orders or acknowledge their authority, without his permission. 'I will never,' said the monarch, 'suffer any person who refuses me the securities of a subject to enjoy estates in my dominions.' He separated the ecclesiastical from the civil courts, with which they had hitherto been conjoined; and he deprived the clergy of many of their lands, and subjected the rest to military service. Obligated to yield to the obstinacy of the English monarch, whose name struck terror into the boldest hearts, the restless pontiff addressed his imperious mandates where he imagined they would be received with more facility. Had the success of that pontiff been equal to the extent of his insolent views, all the kingdoms of Europe would have been, at this day, tributary to the Roman see, and its princes the soldiers or vassals of St. Peter, in the person of his pretended vicar upon earth. But, though his most important projects were ineffectual, many of his attempts were crowned with a favorable issue; for, from the time of his pontificate, the face of Europe underwent a considerable change, and the prerogatives of the emperors and other sovereign princes were much diminished. The first idea of reconquering Palestine from the Arabs and the Turks, by an army of Christians, is attributed to Gregory VII. To him also may be ascribed the origin of indulgencies; of those

Vol. XVIII.

pardons for another life, whatever crimes might be committed in this; of those bills of exchange on heaven, for which, in the end, the popes paid so dearly on earth, and the traffic in which, carried to a disgusting excess, became the first accidental cause of the Reformation. Mosheim has thus summed up the character of this celebrated pontiff:—'He was,' says that author, 'a man of uncommon genius, whose ambition in forming the most arduous projects was equalled by his dexterity in bringing them into execution; sagacious, crafty, and intrepid, nothing could escape his penetration, defeat his stratagems, or daunt his courage; haughty and arrogant, beyond all measure; obstinate, impetuous, and intractable, he looked up to the summit of universal empire with a wishful eye, and labored up the steep ascent with uninterrupted ardor and invincible perseverance. Void of all principle, and destitute of every pious and virtuous feeling, he suffered little restraint in his audacious pursuits from the dictates of religion or the remonstrances of conscience.'

The death of Gregory neither restored peace to the church nor tranquillity to the state; the tumults and divisions which he had excited still continued, and they were augmented from day to day by the same passions to which they owed their origin. During the pontificate of Urban II., successor to Gregory, the project of reconquering Palestine from the Mahometans was renewed by the enthusiastic zeal of an inhabitant of Amiens, who was known by the name of Peter the Hermit, and who suggested to the Roman pontiff the means of accomplishing what had been unluckily suspended. If we examine the motives that engaged the Roman pontiffs, and particularly Urban II., to kindle this holy war, which in its progress and issue was so detrimental to almost all the countries of Europe, we shall probably be persuaded that its origin is to be derived from the corrupt notions of religion which prevailed in these barbarous times. It was thought inconsistent with the duty and character of Christians to suffer that land that was blessed with the ministry, and distinguished by the miracles of the Saviour of men, to remain under the dominion of his most inveterate enemies. It was also looked upon as a very important branch of true piety to visit the holy place of Palestine; which pilgrimages, however, were extremely dangerous while the despotic Saracens were in possession of that country.

Urban was, indeed, inferior to Gregory in fortitude and resolution; he was, however, his equal in arrogance and pride, and surpassed him greatly in temerity and imprudence. Gregory had never carried matters so far as to forbid the bishops and the clergy to take the oath of allegiance to their respective sovereigns. This rebellious prohibition was reserved for the audacity of Urban, who published it as a law in the council of Clermont. In the same spirit he seduced Conrad, the son of Henry IV., into rebellion against his father, by persuading him that it was lawful for subjects to break their oath of allegiance to all such as were excommunicated by the pope. Two years afterwards, in 1099, both Conrad and the pope died; the latter being

2 U

succeeded in the papal chair by Paschal II. (another Gregory), and the former by his younger brother Henry, as king of Italy. Paschal, unwilling to let pass unimproved the present success of the papal faction, renewed in a council assembled at Rome, A. D. 1102, the decrees of his predecessors against investitures, and the excommunications they had thundered out against Henry IV.; and used his most vigorous endeavours to raise up on all sides new enemies to that unfortunate emperor. Henry, however, opposed with great constancy and resolution the efforts of this violent pontiff, and eluded with much dexterity and vigilance his perfidious stratagems. But his heart, wounded in the tenderest part, lost all its firmness and courage, when, in the year 1106, an unnatural son, under the impious pretext of religion, took up arms against his person and his cause. Henry V., so was this monster afterwards named, seized his father in a most treacherous manner, and obliged him to abdicate the empire; after which the unhappy prince retired to Liege, where, deserted by all his adherents, he departed this life in the year 1106. It has been a matter of dispute, whether it was the instigation of the pontiff, or the ambitious and impatient thirst after dominion that engaged Henry V. to declare war against his father; nor is it, perhaps, easy to decide this question. One thing, however, is certain, and that is, that Paschal II. dissolved the oath of fidelity and obedience that Henry had taken to his father; and not only so, but adopted the cause, and supported the interest of this unnatural rebel with the utmost zeal, assiduity, and error. The revolution that this caused in the empire, was, however, much less favorable to the views of Paschal, than that lordly pontiff expected. The pope had the mortification to find that the new emperor was determined, equally with his predecessors, to maintain his right to investitures.

Nor was the king of England more disposed to a surrender of his rights. On a reference by Anselm, archbishop of Canterbury, to the pope, on the subject of doing homage for the temporalities of his see, the messengers returned with an answer, in which the pope insisted on this point, and supported it by the strangest distortion of scripture: 'I am the door; by me if any man enter in he shall be saved. He that entereth not by the door into the sheep-fold, but climbeth up some other way, the same is a thief and a robber.' 'If kings,' says the pope, 'take upon themselves to be the door of the church, whosoever enter by them become thieves and robbers, not shepherds. Palaces belong to the emperors, churches to the priest; and it is written, 'render unto Cæsar the things that are Cæsar's, and unto God the things that are God's.' How shameful is it for the mother to be polluted in adultery by her sons! If, therefore, O king, thou art a son of the church, as every Catholic Christian is, allow thy mother a lawful marriage, that the church may be wedded to a legitimate husband, not by man, but by Christ. It is monstrous for a son to beget his father, a man to create his God: and that priests are called Gods, as being the vicars of Christ, is manifested in scripture.

Such arguments were more likely to increase than satisfy a prince of Henry Beaulieu's understanding. He commanded Anselm either do homage or leave the kingdom, and Anselm with equal firmness replied that he would do neither. A second reference to Rome ensued, two monks were deputed thither by the prince, three bishops by the king. The pope on this occasion acted with a consummate duplicity, in which the motive is not apparent. To the bishops he said that, as their king was in all respects so excellent a prince, he would consent to his granting investitures; but he would send him a written concession lest it might come to the knowledge of other princes, and he should thereby be encouraged to despise the papal authority. By the monks he sent letters to Anselm, exhorting him to persist in his refusal. Both parties made their report before a great council of the realm; the prelates solemnly asseverating that they faithfully repeated what had passed between them and the pope, the monks producing their letters. On the one part it was contended that oral testimony might not be admitted against written documents; on the other, that the solemn declaration of three prelates ought to outweigh the word of two monks and a sheet of sheep's skin with a leaden seal. To this it was replied that the gospel itself was contained in skins of parchment. If, however, it was not easy to determine what had been the real decision of the pontiff, his double dealing was palpable; and Anselm may have been influenced by a proper feeling of indignation when he so far conceded to the king as no longer to refuse communion with those bishops who had received investiture from his hands. At length, by Henry's desire, Anselm went to Rome to negotiate there in person; and the matter ended in a compromise, that no laymen should interfere by delivery of the ring and crosier, but that prelates should perform homage for their temporalities. During these disputes no council had been held in England, and therefore a great decay of discipline was complained of. The marriage of the clergy was what Anselm regarded as the most intolerable of all abuses. This abuse had grown out of it, that the son succeeded by inheritance to his father's church-customer which, if it had taken root, would have formed the clergy into a separate caste. This therefore, was justly prohibited; but it was found necessary to dispense with a canon which forbade the ordination or promotion of the son of priests, because it appeared that the best qualified, and the greater part of the clergy were in that predicament. Canons, each severer than the last, were now enacted for the purpose of compelling them to celibacy. Married priests were required immediately to put away their wives, and never to see, or speak to them, except in cases of urgent necessity, and in the presence of witnesses. They who disobeyed were to be excommunicated; their goods forfeited, their wives reduced to servitude, as slaves to the bishop of the diocese. The wife of a priest was to be banished from the parish in which her husband resided, and condemned to slavery, if she ever held any intercourse with him.

Woman might dwell with a clergyman, except she were his sister or his aunt, or of an age to which no suspicion could attach. In 1107 the pope presided in a council at Troyes, consisting of the bishops from many places, who proved themselves to be wholly subservient to the ambition of the court of Rome, by confirming all the decrees relating to the pretended papal right to investitures.

Henry set out for Rome at the head of a formidable army, and effected a compromise, A. D. 1110. This transitory peace, however, was followed by greater tumults and more dreadful wars than had yet afflicted the church. Immediately after the conclusion of the treaty Rome was filled with the most vehement commotions, and a loud clamor was raised against the pontiff, who was accused of having violated, in a scandalous manner, the duties and dignities of his station; and having prostituted the majesty of the church by his ignominious compliance with the demands of the emperor. To appease these commotions, Paschal assembled in the year 1112 a council in the Lateran church, and not only confessed, with contrition and humility, the fault he had committed in concluding such a convention with Henry, but submitted the question to the determination of the council, who accordingly took that treaty into consideration, solemnly annulled it, and sanctioned the excommunication of the emperor. Hostilities were carried on by both parties till 1117, when Henry resolved to bring matters to a crisis, and set out a second time for Italy at the head of a numerous army. But in the midst of these warlike preparations, which drew the attention of Europe, and portended great and remarkable events, the military pontiff yielded to his fate, and concluded his days, A. D. 1118. A few days after the death of Paschal, John of Gaieta, a Benedictine monk of Mount Cassin and chancellor of the Roman church, was raised to the pontificate under the title of Gelasius II. In opposition to this choice, Henry elected to the same dignity Maurice Burdin, archbishop of Braga, in Spain, who assumed the denomination of Gregory VIII.; upon this Gelasius, not thinking himself safe at Rome, or indeed in Italy, set out for France, and soon after died at Clugni. The cardinals who accompanied him in his journey, elected to the papacy immediately after his decease, Guy, archbishop of Vienne, count of Burgundy, who was nearly related to the emperor, and is distinguished in the list of the Roman pontiffs by the name of Calixtus II. The elevation of this eminent ecclesiastic was in the issue extremely fortunate. Remarkably distinguished by his illustrious birth, and still more by his noble and heroic qualities, this magnanimous pontiff continued to oppose the emperor with courage and success. He made himself master of Rome, threw into prison the pontiff that had been chosen by the emperor, and fomented the civil commotions in Germany. But his fortitude and resolution were tempered with moderation, and accompanied with a spirit of generosity and compliance, which differed much from the obstinate arrogance of his lordly predecessors. Accordingly, he lent an ear to prudent councils, and was willing to

relinquish a part of the demands upon which the former pontiffs had so vehemently insisted, that he might restore the public tranquillity, and satisfy the ardent desires of so many nations, who groaned under the dismal effects of these deplorable divisions. Calixtus did not long enjoy the fruits of the peace to which he had so much contributed by his prudence and moderation, for he died A. D. 1120.

The warm contest between the emperors and the popes, which was considered as at an end since the time of Calixtus II., was unhappily renewed under the pontificate of Adrian IV., who was a native of England, and whose original name was Nicholas Breakspear. Frederick I., surnamed Barbarossa, being placed in 1152 on the imperial throne, publicly declared his resolution to maintain the dignity and privileges of the Roman empire in general, and more particularly to render it respectable in Italy; nor was he at all studious to conceal the design he had formed of reducing the over-grown power and opulence of the pontiffs and clergy within narrow limits. Adrian, perceiving the danger that threatened the majesty of the church and the authority of the clergy, prepared himself for defending both with vigor and constancy. The first occasion of trying their strength was offered at the coronation of the emperor at Rome, in the year 1155, when the pontiff insisted on Frederick performing the office of equerry, by holding the stirrup to his holiness. This humbling proposal was at first rejected with disdain by the emperor. An open rupture between the emperor and the pontiff was expected as the inevitable consequence of such measures, when the death of Adrian, which happened on the 1st of September, 1159, suspended the storm.

Guy, cardinal of St. Calixtus, was elected pontiff A. D. 1164, under the auspices of the emperor, by the title of Paschal III. In the mean time Alexander III., who had been chosen by the cardinals, recovered his spirits, and, returning into Italy, maintained his cause with uncommon resolution and vigor, and not without some promising hopes of success. He held at Rome, in the year 1167, the Lateran council, in which he solemnly deposed the emperor, whom he had upon several occasions before this period publicly loaded with anathemas and execrations; dissolved the oath of allegiance which his subjects had taken to him as their lawful sovereign, and encouraged and exhorted them to rebel against his authority, and to shake off his yoke. But soon after this audacious proceeding Frederick made himself master of Rome; upon which the insolent pontiff fled to Benevento, and left the apostolic chair to Paschal his competitor. The affairs of Alexander soon after took a more prosperous turn, and the emperor, after having, during the space of three years, been alternately defeated and victorious, was at length so fatigued with the hardships he had suffered, and so dejected at a view of the difficulties he had yet to overcome, that, in the year 1177, he concluded a treaty of peace at Venice with Alexander, and a truce with the rest of his enemies. It was not only by force of arms, but also by uninterrupted efforts of dexterity and artifice, by wise counsel

and prudent laws, that Alexander III. maintained the pretended rights of the church and extended the authority of the Roman pontiffs. For, in the third council of the Lateran, held at Rome A. D. 1179, the following decrees, among many others upon different subjects, were passed by his advice and authority:—1st. That, in order to put an end to the confusion and dissensions which so often accompanied the election of the Roman pontiffs, the right of election should not only be invested in the cardinals alone, but also that the person in whose favor two-thirds of the college of cardinals voted should be considered as the lawful and duly elected pontiff.' This law is still in force; it was, therefore, from the time of Alexander that the election of the pope acquired that form which it still retains, and by which not only the people, but also the Roman clergy, are excluded entirely from all share in the honor of conferring that important dignity. 2dly. A spiritual war was declared against heretics, whose numbers increasing considerably about this time created much disturbance in the church in general, and infested, in a more particular manner, several provinces in France, which groaned under the fatal dissensions that accompanied the propagation of their errors. 3dly. The right of recommending and nominating to the saintly order was also taken away from councils and bishops; and canonisation was ranked among the greater and more important causes the cognizance of which belonged to the pontiff alone. To all this we must not forget to add, that the power of erecting new kingdoms, which had been claimed by the pontiffs from the time of Gregory VII., was not only assumed but also exercised by Alexander in a remarkable instance; for, in the year 1179, he conferred the title of king and the ensigns of royalty upon Alphonso I. duke of Portugal, who under the pontificate of Lucius II. had rendered his province tributary to the Roman see. It was during this pontificate that the claims of the Roman priesthood of exemption from temporal jurisdiction, became, in the person of Thomas à Becket, matter of serious dispute between the king of England and Alexander; the latter refusing to ratify the constitutions of Clarendon; by which it was enacted 'that no appeal in spiritual causes should be carried before the holy see; and, 'that churchmen accused of any crime should be tried in the civil courts.' Although the papal sanction was refused, still much was gained by even the agitation of the question, and by the proof which it afforded of the independence of the English, and its superiority over all papal doctrines and spiritual canons. Rapin says that above 100 murders had been committed by ecclesiastics, not one of whom was so much as punished with degradation; hence the necessity of the king's determination.

In reviewing the state of the church in this century it will appear surprising that the religion of Jesus was not totally extinguished. Relics, which were for the most part fictitious, or at least uncertain, attracted more powerfully the confidence of the people than the merits of Christ. The opulent, whose circumstances enabled them to erect new temples, or to repair or

embellish the old, were looked upon as the happiest of mortals, and were considered as the most intimate friends of the Most High. While they whom poverty rendered incapable of such pompous acts of liberality contributed to the multiplication of religious edifices by their bodily labors, expecting to obtain eternal salvation by these voluntary and painful efforts. This universal reign of ignorance and superstition was dexterously improved to fill the coffers of the church. Indeed all the various ranks and orders of the clergy had each their peculiar method of fleecing the people. The bishops, when they wanted money for their private pleasures, or for the exigences of the churches, granted to their flocks the power of purchasing the remission of the penalties imposed upon transgressors by a sum of money, which was to be applied to certain religious purposes; or, in other words, they published indulgences, which became an inexhaustible source of opulence to the episcopal orders; until the Roman pontiffs, casting an eye upon the immense treasures that the inferior rulers of the church were thus accumulating by the sale of indulgences, thought proper to limit the power of the bishops in this respect, and assumed almost entirely this profligate traffic to themselves. In consequence of this new measure the court of Rome became the general magazine of indulgences; and the pontiffs, when either the wants of the church or the demon of avarice prompted them to look out for new subsidies, published not only a universal, but also a complete, or what they called a plenary, remission of all the temporal pains and penalties which the church had annexed to certain transgressions. They went still farther, and not only remitted the penalties which the civil and ecclesiastical laws had enacted against transgressors, but audaciously usurped the authority which belongs to God alone, and impiously pretended to abolish even the punishments which are reserved in a future state for the workers of iniquity; a step this which the bishops, with all their avarice and presumption, had never once ventured to take.

To justify these measures of the pontiffs a most monstrous and absurd doctrine was now invented, which was modified and embellished by St. Thomas in the following century, and which contained among others the following opinions:—'That there actually existed an immense treasure of merit, composed of the pious deeds and virtuous actions which the saints had performed, beyond what was necessary for their own salvation, and which were therefore applicable to the benefit of others; that the guardian and dispenser of this precious treasure was the Roman pontiff; and that, of consequence, he was empowered to assign to such as he thought proper a portion of this inexhaustible source of merit suitable to their respective guilt, and sufficient to deliver them from the punishment due to their crimes.' It is a most deplorable mark of the power of superstition that a doctrine so absurd in its nature and so pernicious in its effects should yet be retained and defended in the church of Rome. The most illustrious and resolute pontiff that filled the papal chair during this century, and whose exploits make the great-

est noise in Europe, was Lotharius of Segni, cardinal deacon, otherwise known by the name of Innocent III. This pontiff, who was placed at the head of the church in the year 1198, followed the steps of Gregory VII., and not only usurped the despotic government of the church but also claimed the empire of the world, and thought of nothing less than subjecting the kings and princes of the earth to his sceptre. He was a man of learning and application; but his cruelty, avarice, and arrogance, clouded the lustre of the good qualities which his panegyrist have thought proper to attribute to him. In Asia he gave a king to the Armenians; in Europe he usurped the same extravagant privilege in the year 1204, and conferred the regal dignity upon Primislaus duke of Bohemia. The same year he sent to Johannicius, duke of Bulgaria and Walachia, an extraordinary legate, who in the name of the pontiff invested that prince with the ensigns and honors of royalty; while, with his own hand, he crowned Peter II. of Arragon, who had rendered his dominions subject and tributary to the church, and saluted him publicly at Rome with the title of king. We omit many other examples of this frenetic pretension, which might be produced from the letters of this arrogant pontiff, and many other acts of despotism, which Europe beheld not only with astonishment, but also, to its eternal reproach, with the ignominious silence of obedience. The ambition of this pope was not satisfied with the distribution and government of these petty kingdoms. He extended his views farther, and resolved to render the power and majesty of the Roman see formidable to the greatest European monarchs. When the empire of Germany was disputed, towards the commencement of this century, between Philip duke of Suabia, and Otho IV. third son of Henry the Lion, he espoused at first the cause of Otho, thundered out his excommunications against Philip, and upon the death of the latter, which happened in the year 1209, placed the imperial diadem upon the head of his adversary. But as Otho was by no means disposed to submit to this pontiff's nod, or to satisfy to the full his ambitious desires, he incurred, of consequence, his lordly indignation; and Innocent, declaring him by a solemn excommunication unworthy of the empire, raised in his place Frederick II. his pupil, the son of Henry VI. and king of the two Sicilies, to the imperial throne in the year 1212. If a prince attempted to withdraw from this authority, received from heaven, the pontiff anathematized him, expelled him out of the communion of the faithful, and his deluded subjects avoided him like a pestilence. In general he went and solicited the pardon of the irritated vice-god, appealed to him by the most abject submission, and by the acknowledgment of all his rights which the arrogant pontiff demanded; after which the repentant sovereign was re-established in his charge and his honors; and at each similar attempt the power of the popes, sanctioned and increased, became still more strengthened. In the third canon of the fourth Lateran council, which was holden by this pope in 1215, entitled *De Hereticis*, the church excommunicates and anathematizes every heresy which op-

posed the faith which had been established in that church, and condemns all heretics by whatever name they are called. The secular legislatures, whatever be their power or titles, are admonished, and if necessary are, in order to be considered faithful to the church, to exert themselves to the most to exterminate all those whom the church defines to be heretics. If the princes to whom this decree of the church shall come neglect to obey they are subject to excommunication. If it be notified to the pope that the contumacy of any prince be continued more than one year, his vassals may be absolved from their allegiance and his territory be allotted to another who shall exterminate heretics and maintain the faith in its purity. 'Under this young and ambitious priest,' says Gibbon, 'the successors of St. Peter attained the full meridian of their greatness; and in a reign of eighteen years he exercised a despotic command over the emperors and kings whom he raised and deposed over the nations; whom an interdict of months or years deprived, for the offence of their rulers, of the exercise of Christian worship. In the councils of Lateran he acted as the ecclesiastical, almost as the temporal, sovereign of the east and west. But of all the European princes none felt in so dishonorable and severe a manner the despotic fury of this insolent pontiff as John, surnamed *Sans Terre*, king of England.' See our article ENGLAND.

Innocent may boast of the two most signal triumphs over sense and humanity, the establishment of transubstantiation by the councils of Lateran in 1215, and the origin of the inquisition. At his voice two crusades, the fourth and the fifth, were undertaken: but, except a king of Hungary, the princes of the second order were alone at the head of the pilgrims; the forces were inadequate to the design; nor did the effects correspond with the hopes and wishes of the pope and the people. Innocent did not confine his efforts to the holy land, he promoted a crusade against the Albigenes. He first attempted to convert them by his missionaries, one of whom was murdered, which was the signal for the display of all his wrath; he did not even deign to institute an enquiry, but ordered the whole race to be pursued with fire and sword, and to be treated with more severity than the Saracens themselves. About 200,000 lives were sacrificed in the terrible war in a few months, and barbarities practised, before unheard of; but the perpetration of them was applauded or rewarded by the cruel pontiff, and the infernal spirit by which they had been actuated was impiously called zeal in supporting the cause of God and of the church. In the year 1216 Innocent undertook a journey to Pisa; but on his arrival at Perugia he was attacked with a violent disorder, which put an end to his life in a few days. Mr. Berington observes of this pope that 'the prerogative of the holy see, built up by adulation and misjudging zeal, filled his mind; and the meteor of universal empire gleaming on his senses did not permit the operation of a dispassionate and unbiassed judgment. No tears were shed when Innocent fell, but those which religion wept, too justly pained by the inordinate exertions and worldly views of her first minister.'

In the year 1227 Hugolin, bishop of Ostia, whose advanced age had not extinguished the fire of his ambition, nor diminished the firmness and obstinacy of his spirit, was raised to the pontificate, assumed the title of Gregory IX., and kindled the feuds and dissensions that had already secretly subsisted between the church and the empire, into an open and violent flame. He wrote to the emperor, Frederick II., exhorting him to fulfil the solemn promises which he had made to embark a sufficient army for the relief of the Christians in the east, adding the severest menaces if he should decline the undertaking. Frederick, obedient to the order, at length embarked for Palestine; but, not having sued for absolution before his departure, he was still the object of Gregory's resentment, who took every method to render his expedition fruitless, and to excite civil wars in his Italian dominions. Frederick, having received information of these perfidious and violent proceedings, returned into Europe in the year 1229, defeated the papal army, retook the places he had lost in Sicily and in Italy, and in the succeeding year made his peace with the pontiff from whom he received a public and solemn absolution. The peace, however, was but of a short duration; for the emperor could not tamely bear the insolent proceedings and the imperious temper of Gregory. He therefore broke all measures with that headstrong pontiff, which drew the thunder of the Vatican anew upon the emperor's head in the year 1230. Frederick was excommunicated publicly with all the circumstances of severity that vindictive rage could invent, and was charged with the most flagitious crimes, and the most impious blasphemies, by the exasperated pontiff. The emperor on the other hand defended his injured reputation by solemn declarations in writing, and appealed for a more efficient vindication to his sword. To extricate himself from his perplexities, the pope convened, in the year 1240, a general council at Rome, with a view of deposing Frederic by the unanimous suffrages of the cardinals and prelates that were to compose that assembly. But the emperor disconcerted that audacious project by defeating in the year 1241 a Genoese fleet, on board of which the greatest part of these prelates were embarked, and by seizing with all their treasures those reverend fathers, who were all committed to close confinement. This disappointment, together with the approach of the emperor and his victorious army, gave such a shock to the pope, that he was seized with an illness which put an end to his life in a few days, after he had been at the head of the church nearly fifteen years. It was during this pontificate that the inquisition was established. See INQUISITION.

After the death of Clement IV., in 1268, the Roman see was vacant for nearly three years, owing to the intrigues of the cardinals, assembled at Viterbo, who all aspired to the dignity themselves and opposed the election of any other. They ultimately chose Theobald, who was at that time with the crusaders in the east. As he had been an eye witness of the miserable condition of the Christians in that country, he had nothing so much at heart as the desire of

contributing to their relief; and, immediately after his consecration, he summoned a council at Lyons in the year 1274, in which the relief and maintenance of the Christians in Palestine, and the reunion of the Greek and Latin churches, were the two points that were to come principally under deliberation. This assembly is acknowledged as the fourteenth general council, and is rendered particularly remarkable by the new regulations that were introduced into the manner of electing the Roman pontiff, and more especially by the famous law which is still in force, and by which it was enacted that the cardinal electors should be shut up in the conclave during the vacancy of the pontificate. Theobald, who had assumed the title of Gregory X., died soon after the termination of the council, having held the Roman see four years and four months. During sixteen years several popes successively occupied the papal chair, but nothing occurs in their history worthy of special notice. Innocent V., who succeeded Gregory, was, before his exaltation, an eminent divine and diligent writer, but died soon after his consecration. Adrian V. died at Viterbo before his consecration. Petro Juliani, formerly a learned physician at Lisbon, succeeded Adrian. He was killed by the roof of his apartment falling in upon him, A. D. 1277. After a delay of six months Nicholas III. was elected. He was a great patron of the Franciscans. To him succeeded Martin IV. a French cardinal, through the intrigue of Charles, king of Sicily, under whose influence his whole conduct was regulated. He died A. D. 1285. Honorius IV. now filled the vacant see; he was in no respect distinguished either by talent or fortune. He was succeeded, A. D. 1288, by the cardinal bishop of Preneste, and assumed the name of Nicholas IV., during whose pontificate the Holy Land which had been rescued by the crusaders from the Turks was now irrecoverably lost. The death of Nicholas IV. in 1292 was followed by a vacancy of two years in the see of Rome, in consequence of the disputes that arose among the cardinals about the election of a new pope. These disputes were at length terminated, and the contending parties united their suffrages in favor of Peter, surnamed De Murrone, from a mountain where he had hitherto lived in the deepest solitude, and with the utmost austerity. This venerable old man, who was in high renown on account of the remarkable sanctity of his life and conversation, was raised to the pontificate in the year 1294, and assumed the name of Celestine V. But the austerity of his manners being a tacit reproach upon the corruption of the Roman court, and more especially upon the luxury of the cardinals, rendered him extremely disagreeable to a degenerate and licentious clergy; several of the cardinals therefore, and particularly Benedict Caietan, advised him to abdicate the papacy which he had accepted with such reluctance; and they had the pleasure of seeing their advice followed with the utmost docility. The good man resigned his dignity in the fourth month after his election, and died in the year 1296, in the castle of Fumone, where his tyrannical and suspicious successor kept him in captivity.

III. *Decline of the papal power.*—The acts of the papal omnipotence during its course, were the humiliation, urged to excess, of all Christian princes and people; rebels supported and encouraged every where against the legitimate authority, when that of the pope was in opposition to it; sovereigns dispossessed and excommunicated as well as their subjects; crowns taken away, given, sold, according to the interests or passions of the pontiff: the bishops and clergy of all the Catholic countries subjected to his will, receiving from him the investiture of their charges, and holding them almost exclusively of him; so that the hierarchy every where formed a state within a state, under the dominion of a foreign despotic chief, who by its means disposed of all the consciences, and of nearly all the riches of a country. The decline of this injurious power, like its progress, has been gradual and almost imperceptible. The commencement of this important change may be dated from the quarrel between the French king and Benedict Caietan, who, after persuading Celestine V. to resign, was advanced to the pontificate by the title of Boniface VIII. A. D. 1294. The beginning of the following year he was enthroned at Rome with great solemnity and parade; in the procession from St. Peter's, where he was consecrated and crowned, to the Lateran, for the purpose of being enthroned, he was mounted on a white horse richly caparisoned, with the crown on his head, whilst the king of Apulia held the bridle in his right hand, and the king of Hungary in the left, both on foot. His subsequent conduct corresponded to the haughty grandeur of his installation. From the moment that he entered upon his new dignity he laid claim to a supreme and irresistible dominion over all the powers of the earth, both spiritual and temporal; terrified kingdoms and empires with the thunder of his bulls; called princes and sovereign states before his tribunal to decide their quarrels; augmented the papal jurisprudence with a new body of laws; declared war against the family of Colonna, who disputed his title to the pontificate; in a word exhibited to the world a lively image of the tyrannical administration of Gregory VII., whom he surpassed in arrogance. Boniface added to the public rites and ceremonies of the church the famous jubilee, which is still celebrated at Rome with the utmost profusion of pomp and magnificence. In the bull issued on this occasion it was enacted, as a solemn law of the church, that those who every hundredth year confessed their sins, and visited with sentiments of contrition and repentance the church of St. Peter and St. Paul at Rome, should obtain thereby the remission of their various offences. As this jubilee added to the splendor and augmented the revenues of the church, later popes have rendered its return more frequent, and fixed its celebration to every twenty-fifth year. The most important event, however, which transpired during this pontificate, was the contest with Philip the Fair, to which we have already alluded. This prince, who was endowed with a bold and enterprising spirit, soon convinced Europe that it was possible to set bounds to the overgrown arrogance of the

bishop of Rome, although many crowned heads had attempted it without success. Boniface sent Philip the haughtiest letters imaginable, in which he asserted that the king of France, and all other kings and princes, were obliged by a divine command to submit to the authority of the popes, as well in all political and civil matters as in those of a religious matter. The king answered him with great spirit, and in terms expressive of the utmost contempt. The pope rejoined with more arrogance than ever; and, in the famous bull *unam sanctam*, which he published A. D. 1302, asserted that Jesus Christ had granted a twofold power to his church, or, in other words, the spiritual and temporal sword; that he had subjected the whole human race to the authority of the Roman pontiff, and that all who dared to dispute it were to be deemed heretics, and excluded from all possibility of salvation. Irritated by the insolence of the pontiff, Philip caused him to be apprehended in his own states by a few soldiers under the conduct of the chancellor Nogaret. Boniface died a few weeks after of an illness occasioned by the rage and anguish into which these insults had thrown him. Benedict XI., who succeeded, learned prudence by the fatal example of his predecessor Boniface, and pursued more moderate and gentle measures. He repealed of his own accord the sentence of excommunication that had been thundered out against the king of France and his dominions. Benedict died A. D. 1304, upon which Philip, by his artful intrigues in the conclave, obtained the see of Rome for Bertrand de Got, archbishop of Bordeaux, who was accordingly elected to that high dignity on the 5th of June, 1305. Bertrand assumed the name of Clement V., and at the king's request remained in France, and removed the papal residence to Avignon, where it continued during the space of seventy years. There is no doubt that the continued residence of the popes in France greatly impaired the authority of the Roman see. The French pontiffs finding they could draw but small revenues from their Italian dominions, which were now torn in pieces by faction and ravaged by sedition, were obliged to contrive new methods of accumulating wealth. For this purpose they not only sold indulgences to the people more frequently than they had formerly done, whereby they made themselves extremely odious to several potentates, but also disposed publicly of scandalous licenses of all sorts at an excessive price. John XXII., who succeeded Clement, was remarkably shrewd and zealous in promoting this abominable traffic, and was the first to assume the triple crown; his reign was one continued scene of confusion and contention between him and Lewis of Bavaria, who claimed the imperial crown. To him succeeded Benedict XII., a man of great probity, who sought to correct the abuses and to redress the grievances of the church as far as practicable. His successor in 1342 was Peter Roger, who assumed the name of Clement VI. The character of this pontiff may be inferred from the bull of anathema issued against the emperor Lewis of Bavaria, in which he thus expresses himself:—'May God strike him with imbecility



and madness; may heaven overwhelm him with its thunders; may the anger of God, with that of St. Peter and St. Paul, fall upon him in this world and in the next; may the whole universe revolt against him; may the earth swallow him up alive; may his name perish from the earliest generations; and may his memory disappear; may all the elements be adverse to him; may his children, delivered into the hands of his enemies, be crushed before the eyes of their father, &c.' Innocent VI., the successor of Clement, whose name was Stephen Albert, possessed more integrity and moderation. He was a Frenchman, and before his election had been bishop of Ostia. He made it his business to correct abuses, and also abolished the heavy impositions laid upon the clergy when preferred to any new benefice or dignity. He retrenched all the unnecessary expenses of the papal court, contenting himself even with a small number of attendants; he obliged the cardinals to follow his example, urging them to bestow the superabundance of their wealth in relieving the necessities of the poor. To Innocent succeeded Urban V., A. D. 1362, whose pontificate presents nothing worthy of notice. He is said to be the first who wore the triple crown. Gregory XI., nephew to pope Clement VI., earnestly desired to remove the seat of the papal see back from Avignon to Rome, but was prevented by the disturbances in Italy. He greatly opposed Wycliff; and in his will frankly acknowledged his fallibility; he died at Rome A. D. 1378. After the death of Gregory, the cardinals were assembled to consult about choosing a successor, when the people of Rome, unwilling that the vacant dignity should be conferred on a Frenchman, came in a tumultuous manner to the conclave, and with clamors, accompanied with outrageous menaces, insisted that an Italian should be advanced to the popedom. The cardinals, terrified by this uproar, immediately proclaimed Bartholomew Pregnano, who was a Neapolitan, and archbishop of Bari, and assumed the name of Urban VI. This new pontiff, by his impolitic behaviour, entailed upon himself the odium of people of all ranks, and especially of the leading cardinals. These latter therefore, tired of his insolence, withdrew from Rome to Anagni, and thence to Fondi, a city in the kingdom of Naples, where they elected to the pontificate Robert, count of Geneva, who took the name of Clement VII., and declared at the same time that the election of Urban was nothing more than a mere ceremony which they had found themselves obliged to perform in order to calm the turbulent rage of the populace. Urban remained at Rome: Clement went to Avignon in France. His cause was espoused by France and Spain, Scotland, Sicily, and Cyprus, while all the rest of Europe acknowledged Urban to be the true vicar of Christ. Thus the union of the Latin church under one head was destroyed at the death of Gregory XI., and was succeeded by that memorable dissension commonly known by the name of the Great Western Schism.

This dissension was fomented with such dreadful success, and arose to such a shameful height, that for the space of fifty years the church had

two or three different heads at the same time; each of the contending popes forming plots, and thundering out anathemas, against his competitors. During these dissensions the fires of persecution were not permitted to die away. In England archbishop Arundel, at the instigation of the popes, became both a persecutor and a traitor; he urged Henry IV., who had usurped the throne by the aid of the clergy, to pass a statute whereby all who propagated the doctrines of Wickliff, by preaching, writing, teaching, or discourse, were required to renounce their heresies, deliver in all their heretical books, and submit themselves to the church, on pain of being delivered over to the secular arm, and burnt alive. To give further efficacy to this bloody statute, Arundel set forth several provincial constitutions, whereby any persons preaching doctrines contrary to the determination of the church, or calling in question what the church had determined, were to be excommunicated, ipso facto, on the first offence, and declared heretics for the second. Whoever read the books of Wickliff or his disciples, without a licence from one of the universities, was to suffer as a promoter of heresy. The greater excommunication was to be incurred by advancing propositions, even in the schools, which tended to subvert the Catholic faith. It was declared heresy to dispute the utility of pilgrimages, or the adoration of images, and of the cross. The proceedings against offenders in this case were to be as summary as in cases of treason. And, because it was difficult to retain the true sense of Scripture in translations, whoever should translate it, or read such translations, particularly Wickliff's, without the approbation of his ordinary, or of a provincial council, was to be punished as a promoter of heresy. That this statute was not suffered to become obsolete may easily be imagined, as may be seen, under the articles REFORMATION and WICKLIFF. The hopes that Urban's death would end the divisions of the Romish church, or at least forward a reconciliation, were soon disappointed. The cardinals then in Rome chose Peter Iomacelli, a Neapolitan cardinal priest, who succeeded to the papacy as Boniface IX., whose determined resolution it was to maintain his dignity. He and Clement renewed the excommunication against each other and their respective friends; and were more adverse to peace than any of their adherents. Many from a sense of the evils of this separation made proposals for restoring tranquillity. Among these were the proposals of the university of Paris, that both should resign; or that the matter should be left to arbitration; or that a general council should decide it. Neither of the rival pontiffs was inclined to this, though they acted very artfully towards each other, and endeavoured to deceive one another. Boniface retired to Perugia, and Clement died at Avignon, A. D. 1394. The cardinals at Avignon proceeded to a new election, and bound themselves by oath that the newly elected pontiff should faithfully labor to restore peace, even by the method of cession, if that should be approved of by the majority of suffrages in the college of cardinals. Cardinal Peter de Luna,

who took the name of Benedict XIII., being promoted, so far from fulfilling the fair promises he had made though confirmed by an oath, defeated all pacific endeavours by an unparalleled obstinacy. After various changes of fortune, Benedict sent a legation to Boniface, with overtures towards an accommodation; but the death of the latter terminated the treaty. Upon the death of Boniface IX. the cardinals of his party raised to the pontificate, in the year 1404, Cosmo de Meliorate, who assumed the name of Innocent VII., and held that high dignity during the short space of two years only. After his decease Angelo Corraris, a Venetian cardinal was chosen in his room, and ruled the Roman faction under the title of Gregory XII. A plan of reconciliation was, however, formed, and the contending pontiffs bound themselves each by an oath to make a voluntary renunciation of the papal chair, if that step should be deemed necessary to promote the peace and welfare of the church; but they both scandalously violated this obligation. Benedict besieged in Avignon by the king of France, in the year 1408, saved himself by flight, retiring first into Catalonia his native country, and afterwards to Perpignan. Hence eight or nine of the cardinals who adhered to his cause, seeing themselves deserted by their pope, went over to the other side, and, joining publicly with the cardinals who supported Gregory, they agreed together to assemble a council at Pisa on the 25th of March 1409, in order to heal the divisions and factions that had so long rent the papal empire. This council, however, which was designed to close the wounds of the church had an effect quite contrary to that which was generally expected, and only served to open a new breach, and excite new divisions. Its proceedings indeed were vigorous, and its measures were accompanied with a just severity. A heavy sentence of condemnation was pronounced, on the 5th day of June, against the contending pontiffs, who were declared guilty of heresy, perjury, and contumacy, unworthy of the smallest tokens of honor or respect, and separated, *ipso facto*, from the communion of the church. This step was followed by the election of one pontiff in their place. The election took place on the 15th of June, and fell upon Peter of Candia, known in the papal list by the name of Alexander V.; but all the decrees and proceedings of this famous council were treated with contempt by the condemned pontiffs, who continued to enjoy the privileges and to perform the functions of the papacy, as if no attempts had been made to remove them from that dignity. Benedict held a council at Perpignan; and Gregory assembled one near Aquileia, in the district of Friuli. The latter, however, apprehending the resentment of the Venetians, made his escape in a clandestine manner from the territory of Aquileia, arrived at Caieta, where he threw himself upon the protection of Ladislaus, king of Naples, and in 1412 fled thence to Remini.

Thus was the Catholic church divided into three great factions, and its government violently carried on by three contending chiefs, who loaded each other with reciprocal maledictions,

calumnies, and excommunications. Alexander V., who had been elected pontiff at the council of Pisa, died at Bologna in 1410, and the sixteen cardinals who attended him in that city immediately filled up the vacancy, by choosing as his successor Balthasar Cossa, a Neapolitan destitute of all principles both of religion and probity, who assuming the title of John XXIII. soon afterwards appealed to all Christian princes to appoint a general council, to put a stop to the reigning evils, and to unite the whole church under one head. The choice of the place was left to the emperor, who fixed on Constance. Here the council was opened on the 1st of November, 1414. The pope appeared in person, attended by a great number of cardinals and bishops at this famous council; which was also honored with the presence of the emperor Sigismund, and of a great number of German princes, and with that of the ambassadors of all the European states, whose monarchs or regents could not be personally present at the decision of this important controversy. After the members of the council had deliberated, some acknowledged the legality of the council of Pisa; while the greater number disowned it, decreeing at the same time that John XXIII. as well as Gregory XII. and Benedict XIII. should entirely renounce his claims to the pontificate. Thus was John mortified by disappointment at the moment he expected a triumph; but what inflicted a still deeper wound on his feelings was the resolution with which they vindicated the privileges of the council. Conscious of their strength, they declared that the representatives of the church, in general council assembled, were superior to the sovereign pontiff; not only when schism prevailed, but at all other times whatever. This was one of their earliest acts.

Although John was disheartened by this rigorous sentence, he yet prepared to appear before the council; and there to maintain that he could not be deposed except on the score of heresy. The dissuasion of his friends, however, altered his determination; at their instance, too, he was induced to resign the papal dignity, on condition that his competitors would do the same. A renunciation to this effect was accordingly drawn up by the council, publicly read, and subscribed in due form by himself. Notwithstanding this solemn act, by which he bound himself to God, and to the council, that he would voluntarily give peace to the church by his abdication of the pontificate, and not leave Constance before the council had concluded its sittings, did he forswear himself, and violate his promise. John's flight from Constance in disguise created some consternation: his friends in the council maintaining that its functions ceased on the retreat of the pope; while the majority contended for the superiority of the council over every person, not even excepting the pope, in matters relating to faith, the extirpation of schism, and the general reformation of the church. Negotiations ensued between the council and John, from which it appeared that his only object was to gain time; and that, if nothing favorable to his views occurred, he might engender strife amongst its members, and

cause its dissolution. The council, however, no way disconcerted, although worn out by his excuses, delays, and equivocations, issued citation after citation for John's appearance before them; and, at last, reduced him to a perfect submission to its authority, and to an acknowledgment that it could not err; and that he had no right whatever to the pontifical dignity! Gregory XII. withdrew his claims to the papal chair; while Benedict XIII. was deposed by a solemn decree of the council. After the extinction of this papal triumvirate, Martin V. became the object of their choice; against whose election, however, Benedict protested to the latest hour of his life. After the death of Benedict a new competitor was set up for the pontificate by two of the cardinals, under the title of Clement VIII. But he was afterwards prevailed on to resign, and to leave Martin in undisturbed possession. With his resignation the long disgrace and degradation of the church may be said to have terminated. The great purpose of holding the council of Constance was the healing of the schism by which the church had been so long disturbed, and this was happily accomplished. In the fourth and fifth sessions it was solemnly declared that the Roman pontiff was inferior and subject to a general assembly of the universal church. Before the meeting of this council there were great commotions in several parts of Europe, especially in Bohemia, concerning religious matters.

One of the persons principally implicated in these disputes was John Huss, who lived at Prague in the highest reputation, on account of the sanctity of his manners, the purity of his doctrine, and his uncommon erudition and eloquence. A fouler plot does not stain the page of history than the treatment which he received at the hands of the Constantian fathers. Whatever faults may be attributed to this eminent ecclesiastic—if manly independence in maintaining his opinions, and ardent zeal in exposing the vices which disgraced the conduct of the clergy can be considered faults—they vanish before the recollection of the death to which he was consigned. He was deemed a disobedient son of the church by refusing to renounce his eyesight, and to submit his will and judgment without reservation to the will and judgment of the holy mother. In a word, he refused to yield a servile obedience to ecclesiastical despotism, and therefore his doom was sealed. The leading charge against him was,—his requiring that the laity as well as the clergy should partake of the communion in both kinds. This it was which led him to the stake, where his friend, Jerome of Prague, shortly after perished, for having maintained the same principles. The safe conduct of the former was of the most unqualified description, Jerome's was not so; and therefore he had comparatively less cause of complaint, although this can never justify the cruel punishment to which he was subjected. The pretended safe conduct which the council sent him was so loosely worded, that the fathers could not be charged with a direct violation of faith. 'That no violence may be done to you,

we give you by these presents a plenary safe-conduct, saving nevertheless justice, as far as it is incumbent on us, and as the orthodox faith requires.' Relying, however, on the principle of faith, so insidiously pledged by them, he inconsiderately repaired to Constance, where he soon paid the forfeit of his rashness in the tragical exhibition spoken of.

Before sentence had been pronounced against John Huss and Jerome of Prague, the famous Wickliff, whose opinions they were supposed to adopt, and who was long since dead, was called from his rest before this ghostly tribunal. On the 4th of May, in the year 1415, a long list of propositions, invidiously culled out of his writings, was examined and condemned, and an order was issued out to commit all his works, together with his bones, to the flames. On the 14th of June following the assembled fathers passed the famous decree which took the cup from the laity in the celebration of the eucharist; and ordered 'that the Lord's supper should be received by them only in one kind, i. e. the bread, and rigorously prohibited the communion in both kinds. On the 19th of September of this council it was decreed 'that the safe-conduct granted to heretics by an emperor, king, or any other secular prince, shall not prevent any ecclesiastical judge from punishing such heretics, even if they come to the place of judgment relying on such safe-guard, and would not otherwise come thither.' After this specimen of the proceedings of the council of Constance, it cannot be a matter of surprise that its members separated without effecting the professed object of their meeting, the reformation of the church of Rome. Martin V., who succeeded John, was no sooner raised to the pontificate than he employed his authority to elude and frustrate every effort that was made to set this salutary work on foot; and made it appear most evidently by the laws he enacted, that nothing was more foreign from his intention than the reformation of the clergy, and the restoration of the church to its primitive purity.

Thus this famous council, after sitting three years and six months, was dissolved on the 22nd of April, 1418, and the members postponed to a future assembly of the same kind, which was to be summoned five years after this period, their design of purifying the church. But not five years only, but almost thirteen, elapsed without the promised meeting. The remonstrances, however, of those whose zeal for the reformation of the church interested them in this event, prevailed at length over the pretexts and stratagems that were employed to put it off; and Martin summoned a council to meet at Ravia, whence it was removed to Sienne. This council had for its object the union of the Greek and Latin churches, and the reformation of the church, both in its head and members. One of the few decrees made by this synod was directed against the Hussites, Wickliffites, and other dissentients from the church of Rome; inasmuch as it granted indulgencies to such as extirpated heretics; all exemptions and safe-conducts, by whatsoever persons vouchsafed, to the contrary not

withstanding. After some other business of trifling import was transacted, Martin contrived to have the assembly transferred to Basil.

This event occurred in the year 1431, and may be said to have been the only transaction of consequence in which he was engaged before his death, with the exception of the negociation which he opened with the Greek emperor and the patriarch of Constantinople, in order to put an end to existing differences between the two churches. The pontiff did not live to be a witness of the proceedings of this assembly, being carried off by a sudden death on the 21st of February, 1431, just about the time when the council was to meet. He was immediately succeeded by Gabriel Condolmerio, a native of Venice, and bishop of Sienna, who is known in the papal list by the title of Eugenius IV. This pontiff approved all the measures of his predecessor, in relation to the assembling of the council of Basil, which was accordingly opened on the 23rd of July, 1431, under the superintendence of cardinal Julian Cæsarini, who performed the functions of president in the place of Eugenius. It was now manifest that the assembled fathers were in earnest, and firmly resolved to answer the end and purpose of their meeting; Eugenius, therefore, much alarmed at the prospect of a Reformation, determined to dissolve the council.

The council, however, proceeded vigorously with their measures of reform. On the 25th of March, 1436, a confession of faith was read, which every pontiff was to subscribe on the day of his election; it was voted that the number of cardinals should be reduced to twenty-four; and the papal impositions, called expectatives, reservations, and provisions, were annulled. These measures, with others of a like nature, provoked Eugenius to the highest degree, and induced him to form a design either of removing this troublesome and enterprising council into Italy, or of setting up a new council in opposition to it, which might fix bounds to its zeal for the reformation of the church; and this occasioned a warm and violent contest. The council summoned Eugenius to appear at Basil on the 26th day of July, 1437, in order to give an account of his conduct; but the pontiff, instead of complying with the requisition, issued a decree by which he pretended to dissolve it, and to assemble another at Ferrara. This, indeed, was treated with the utmost contempt by the council, which, with the consent of the emperor, the king of France, and several other princes, continued its deliberations at Basil, and on the 28th of September, in the same year, pronounced a sentence of contumacy against the rebellious pontiff: but in the year 1438 Eugenius in person opened the council which he had summoned to meet at Ferrara, and at the second session thundered out an excommunication in return against the fathers assembled at Basil. In the mean time the latter, after declaring the superiority of councils over the pope to be an article of the Catholic faith, proceeded to depose Eugenius from the papacy, as disobedient to the commands of the church, and an obstinate heretic, and raised to the papal throne Amadeus, duke of

Savoy, who assumed the name of Felix V. This election was the occasion of the revival of the western schism, and it was at this time even more extensive than before, as the flame was kindled not only between rival pontiffs, but also between the contending councils of Basil and Florence. The rival popes and rival councils anathematized each other, laying claim to the true apostolic powers. Eugenius was supported by France, Italy, Spain, Portugal, Hungary, and England: Felix by the people of Savoy, the Swiss, and the dukes of Bavaria and Austria. The German princes chose to preserve a neutrality till the year 1447, when they declared for Eugenius. In the midst of the public rejoicings, on this occasion, he died in his sixty-fourth year. On his death Thomas de Sarzano, bishop of Bologna, was elevated to the pontificate, under the denomination of Nicholas V., under whom the European princes, and more especially the king of France, exerted their warmest endeavours to restore tranquillity, and their efforts were crowned with success. In 1449 Felix V. resigned the papal chair, and returned to his delightful hermitage at Rissalle, while the fathers of the council of Basil assembled at Lausanne ratified his voluntary abdication, and, by a solemn decree, ordered the universal church to submit to the jurisdiction of Nicholas as their pontiff. On the other hand Nicholas proclaimed this treaty of peace with great pomp on the 18th of June, in the same year, and set the seal of his approbation and authority to the acts and decrees of the council of Basil. This pontiff distinguished himself in an extraordinary manner, by his love of learning, and by his ardent zeal for the propagation of the arts and sciences; what was still more laudable, he was remarkable for his moderation, and for the meek and pacific spirit that discovered itself in all his conduct and actions. In the year 1453 Nicholas received intelligence of the capture of Constantinople by Mahomet II.; and some historians mention this fact as the greatest affliction that befel the pope, but Gibbon thinks differently. 'The Roman pontiff,' says he, 'was exasperated by the falsehood or obstinacy of the Greeks. Instead of employing in their favor the arms and treasures of Italy, Nicholas V. had foretold their approaching ruin, and his honor seemed engaged in the accomplishment of his prophecy. Perhaps he was softened by the last extremity of their distress; but his compassion was tardy, his efforts were faint and unavailing, and Constantinople had fallen before the squadrons of Genoa and Venice could sail from their harbours.' From this time he spent the remainder of his pontificate in endeavours to allay the civil wars and commotions which took place in Italy; to reconcile the Christian princes who were then at war with one another; and to unite them against the enemies of the Christian church. In his efforts he was completely unsuccessful, and the disappointment is said to have hastened his death, which happened in 1455, after he had completed the eighth year of his pontificate.

Æneas Sylvius Piccolomini, who succeeded in 1453 to the pontificate, under the title of Pius II., rendered his name illustrious, not only by

his extensive genius, and the important transactions that were carried on during his administration, but also by the various and useful productions with which he enriched the republic of letters. He, however, deplored the mistaken law which compelled the clergy to celibacy, and the intolerable consequences to human happiness and virtue arising from its enactment. The genius and learning of Æneas Sylvius would have shed a lustre over the age which gave him birth, had they continued to be employed in the sphere in which they had at first acquired for him celebrity. In his character of ambassador from the Roman see to different potentates, he acquired the credit of a diplomatist; but it was by his advocacy of the rights and privileges of general councils, and his opposition to papal encroachment and usurpation that he rendered his name illustrious. As secretary to the council of Basil, he was the boast of literature; but, as if he had changed his nature with his name, he disgraced it as Pius II. No longer was his voice raised to elevate the council above the pope, but to recommend blind submission to his authority. It would appear that he gloried in his inconsistency, since he even went so far as to procure a partial repeal of the Pragmatic sanction from the French monarch, which had been solely instituted with the design of curtailing the power of the pope within the Gallican territory; and published, in his pontifical capacity, a solemn retraction in the year 1463 of his defence of the council of Basil.

To Pius succeeded Paul II., of whose pontificate history relates nothing worthy of record. His successor Sixtus IV. was the instigator of a conspiracy to assassinate Giuliano and Lorenzo de Medici, and to change the government of Florence. The assassination was to take place in the principal church, where a cardinal legate was present, and the signal for it was to be the elevation of the host: Giuliano was killed on the spot; Lorenzo was wounded by two priests, who had undertaken his murder, but escaped; the archbishop of Pisa, who in the mean time had attempted to overpower the magistrates and possess himself of the seat of government, failed in his attempt, and was hung in his pontifical robes from one of the windows of the palace. For this act of justice Sixtus excommunicated Lorenzo, and the magistrates of Florence. The bull issued on this occasion has been justly designated one of the most extraordinary specimens of priestly arrogance, that ever insulted the common sense of mankind. Alexander VI., a Spaniard by birth, whose name was Roderic Borgia, succeeded in 1492 to the papal chair. The life and actions of this man show that there was a Nero among the popes, as well as among the emperors. The crimes and enormities that history has imputed to him exhibit him as not only destitute of religious and virtuous principles, but even regardless of decency. By Vanazza, a Roman lady, with whom he had continued an illicit connexion for many years, he had five children: his second son was Cæsar Borgia, a monster of debauchery and cruelty, who is said to have quarrelled with his elder brother for the favors of his sister Lucretia, and to have killed him and thrown his

body into the Tiber. Notwithstanding his infamous character he was the favorite of his father, who trampled with contempt on every obstacle which the demands of justice, the dictates of reason, and the remonstrances of religion laid in his way, in order to aggrandise his family. The profligate career of this execrable hypocrite and tyrant was continued till the year 1503, when the prison which he and his son Cæsar had prepared for others, and particularly for Adrian, a wealthy cardinal, who stood in the way of their avarice and ambition, by a happy mistake, terminated his own days. See BORGIA.

On the death of Alexander, Pius III. occupied the papal throne for only one month; at whose decease the vacant chair was obtained, through fraud and bribery, by Julian De la Rovere, who assumed the denomination of Julius II. To the odious list of vices with which he dishonored the pontificate we may add the most extravagant and frenetic passion for war and bloodshed. He began his military enterprises by entering into a war with the Venetians, after having strengthened his cause by an alliance with the emperor and the king of France. His whole pontificate, in short, was one continued scene of military tumult; nor did he ever suffer Europe to enjoy a moment's tranquillity as long as he lived; fortunately death carried off this audacious pontiff in 1512, in the midst of his ambitious and vindictive projects.

Leo X., of the family of Medicis, ascended the papal throne after the death of Julius. He was a protector of men of learning, and was himself learned as far as the darkness of the age would admit; but wholly indifferent to religion: his time being divided between conversation with men of letters, and the pursuit of pleasure. He had an invincible aversion, we are told, to whatever was accompanied with solitude and care, and was remarkable for his prodigality. He did not, however, lose sight of the grand object which the generality of his predecessors had so much at heart—that of promoting the opulence of the Roman see; for he took the utmost care that nothing should be transacted in the Lateran council (which Julius had assembled and left sitting) that had the least tendency to favor the reformation of the church. He went still farther; and in a conference which he had with Francis I., king of France, at Bologna, engaged that monarch to abrogate the Pragmatic sanction which had been so long odious to the popes, and to substitute, in its place, another body of laws under the title of the Concordat.

It was in the reign of Leo X. that those events transpired which form an era in the history of the Romish church, and indeed in the annals of the world, resulting in the Protestant REFORMATION. For some time there had been a season of comparative tranquillity, and the pontiffs thought themselves thoroughly confirmed in their assumption of power. We must not, however, conclude from this apparent tranquillity and security, that their measures were unanimously applauded, or that their chains were worn without reluctance; for, not only private persons, but also the most powerful princes and sovereign states exclaimed loudly against the despotic dominion

of Rome; the arrogance, tyranny, and extortion of her legates, the unbridled licentiousness and enormous crimes of the clergy and monks of all denominations, the inordinate severity and partiality of the papal laws; and demanded publicly, as their ancestors had done before them, a reformation of the church in its head and members. But these complaints and demands had not hitherto been carried so far as to produce any good effect; since they came from persons who did not entertain the least doubt about the supreme authority of the pope, and who, therefore, instead of attempting, themselves, to bring about that reformation which was so ardently desired, remained entirely inactive, and looked for redress to the court of Rome, or a general council. If any thing seemed likely to destroy the gloomy empire of superstition, and to alarm the security of the lordly pontiffs, it was the restoration of learning in Europe, and the number of men of genius that suddenly arose, under the benign influence of that revolution. The efforts of man cannot eternally prevail against the course of nature. A commerce with distant countries, and the knowledge of a new world, had disposed men to receive new ideas. The art of printing, uniting with the invention of making paper from rags, incalculable advantages to the human race, and the highest which the mind ever received from the hand of industry, multiplied knowledge to infinity, and prevented its longer concealment. The time, therefore, was now arrived, when the papal power was about to receive a shock which it has not been able to, and never will, recover.

Having devoted the article REFORMATION to the details of this important era, we must only glance at them here. The profusion of Leo had rendered it necessary to devise means for replenishing his exhausted treasury, and one of these was the sale of indulgences. The commissioners appointed for this traffic exaggerated in Germany the efficacy of their wares, until Luther, a friar of Wittemberg, warmly protested against this abuse, and published a set of propositions in which he called in question the authority of the pope to remit sins. Luther was of humble origin; his talents alone had raised him to the situation which he filled as professor of philosophy and theology at the university of Wittemberg. Supported, however, by indefatigable zeal, and an enlarged acquaintance with the Holy Scriptures, the fathers, and ecclesiastical antiquities, he overwhelmed the scholastics in every encounter, and covered their science with confusion and ridicule. In his individual character, which had such influence on the reformation, was seen an irresistible union of energy and uprightness. Ardent and calm; high spirited, and at the same time humble; irritable and warm in his language when provoked by injurious treatment; mild and inimical to every species of violence in actions; jovial, open, of ready wit, and even a pleasant companion of the great; studious, sober, and a stoic in himself; courageous and disinterested, he exposed himself with tranquillity to every risk, in support of what he believed to be the truth. Such a man must have been filled with indignation at the approach of the shameless Tetzel. At length, at the ex-

press desire of the emperor Maximilian, Leo summoned Luther to appear before the court of Rome. Permission was, however, subsequently granted for the cardinal of Gæta to hear his defence at Augsburg. Nothing satisfactory was determined; and the pope, in 1518, published a bull, asserting his authority to grant indulgences, which would avail both the living and the dead in purgatory. Upon this the reformer appealed to a general council, and thus open war was declared, in which the abettors of Luther appeared with a strength little calculated upon.

And thus began the Reformation. It found a multitude of minds prepared to receive it, and many enlightened and eloquent men disposed to become its apostles. The learned and moderate Melancthon and Carlostadt, both of Wittemberg; in Switzerland Zuinglius; and in France Calvin, all contributed to the great work. Leo X. engaged all the force of the pen, as well as of civil power, to impede its progress; but in the midst of these efforts he was seized with an illness, which at first was considered as a slight cold only, but which put an end to his life in a few days. This event happened on the 1st of December, 1521, when Leo was in the forty-sixth year of his age, and the ninth of his pontificate. Upon his death the conclave was divided about the choice of a successor. The younger members were attached to Julio cardinal de Medici, the nephew of Leo; but the old cardinals were averse from choosing a pontiff out of the powerful family of the Medici, and yet they were not agreed in their views. By a manœuvre, which was merely designed to gain time, the party of Julio voted for cardinal Adrian in the preparatory scrutiny. The other party closed with them, and thus a stranger to Italy, and a man unqualified for the office, was elected, no less to their own surprise than to the astonishment of Europe. Whilst he demanded a zealous execution of the imperial edict against Luther and his followers, Adrian declared a disposition to exercise his spiritual authority for the reformation of the church; but notwithstanding the just claims on respect which resulted from the pontiff's general conduct, he was very unpopular. He resigned his life and the anxieties of his elevated station in December, 1523, after he had possessed the papal dignity only one year and ten months, and was succeeded by cardinal de Medici, under the name of Clement VII. High expectations were formed of a pope, whose great talents and long experience in business seemed to qualify him no less for defending the spiritual interests of the church, than for conducting its political operations with the prudence requisite at such a difficult juncture; and who, besides these advantages, had in his hands the government of Florence, and the wealth of the family of Medici.

But, Clement having excited the anger of Charles V., the general of the imperial army, in conjunction with his allies, determined to attack and plunder Rome. The resolution was bold, and the execution of it no less rapid. The misery and horror of the scene that followed may be more easily conceived than described. The pillage and cruelty that were exercised on this occasion, exceeded, it is said, those of the Huns,

Vandals, or Goths, in the fifth and sixth centuries. The booty, in ready money alone, amounted to 1,000,000 of ducats. Clement, who had shut himself up in the castle of St. Angelo, being deprived of every resource, and reduced to such extremity of famine as to feed on asses' flesh, was obliged to capitulate on such conditions as the conquerors were pleased to prescribe. He agreed to pay 400,000 ducats to the army; to surrender to the emperor all the places of strength belonging to the church; and, besides giving hostages, remaining a prisoner himself until the chief articles were performed. At length, however, the progress of the confederates in Italy and other political considerations, induced the emperor to concert measures for setting the pope at liberty, on consideration of his allowing 100,000 crowns for the use of the army, paying the same sum at the distance of a fortnight, and at the end of three months 150,000 more.

During a period of six years, Henry VIII. of England had been suing the court of Rome for a divorce from Catharine of Arragon; but the pope negotiated, promised, retracted, and concluded nothing. Cranmer's sentence at length annulled the king's marriage with Catharine; her daughter was declared illegitimate, and Ann Boleyn acknowledged queen of England. Clement, who had already seen so many provinces and kingdoms revolt from the holy see, became apprehensive lest England should follow their example, and determined to give Henry such satisfaction as might still retain him within the bosom of the church. But the violence of the cardinals, devoted to the emperor, hurried him with a fatal precipitation to issue a bull rescinding Cranmer's sentence, enforcing Henry's marriage with Catharine, and declaring him excommunicated, if, within a time specified, he did not return to her. Henry was enraged; the resistance he met with in the accomplishment of his wishes from the court of Rome led him to question its jurisdiction; and the more this was examined the weaker it appeared. From this to question its discipline and doctrines was only another step, and the nation was prepared for it. An act of parliament was therefore passed, abolishing the papal power and jurisdiction in England. By another act the king was declared supreme head of the church, and all the authority of which the popes were deprived was vested in him.

The successes that had attended the allies in their opposition to Clement inspired with new vigour and resolution all the friends of the reformation. Soon after his sentence on Henry, Clement fell into a languishing distemper, which closed his pontificate, after a duration of ten years and ten months, on the 25th of September, 1534. He was succeeded by Alexander Farnese, who assumed the name of Paul III., and whose first object was to crush the progress of the reformation. He was, like his predecessor, enraged at the innovations in Germany, and equally averse from any scheme for reform, either in the doctrines of the church, or the abuses of the papal court. In 1538 he issued his bull of excommunication against Henry VIII. of England, and required all Christian princes, whatever had been their oaths, to render no assistance to Henry.

The year 1540 was rendered memorable by the establishment of the order of the Jesuits. These new soldiers of the church did every thing which could be hoped for from human powers, directed by the most profound zeal, prudence, perseverance, and genius. They soon obtained possession of courts, of nations, of confessions, of pupils, of the education of youth, of missions. Nothing appeared to them impossible in extending the dominion of the holy see to places where it did not exist, or in consolidating it where it was maintained. Represented as ambitious, fomenters of trouble, corrupt men, and even as rebels, by their adversaries, they opposed the stoical severity of their lives, their zeal, and services to the Roman see, and their studious austerity, to these accusations. In a few years the society established itself in every Catholic country; and, acquiring prodigious wealth, soon became the confessors of almost every Catholic prince, and the spiritual guides of nearly every person of rank or influence.

The church and court of Rome, since the remarkable period when so many kingdoms and provinces withdrew from their jurisdiction, have perhaps derived more influence and support from the labours of this single order than from all their other emissaries and ministers. About this time the pope, finding it impossible to avoid any longer calling a general council, sent John Morone, bishop of Modena, to announce to the diet of the empire at Spire his determination of assembling such a council, and published a bull, nominating three cardinals to preside as his legates. These legates repaired to Trent, on the 1st of November, 1542, where they remained several months; but, as no other persons appeared there except a few prelates from the ecclesiastical states, the pope recalled them and prorogued the council. On the 13th of December, 1545, the council was again opened at Trent; though as yet only twenty-five bishops had arrived, and these were Italians or Spaniards. The council showed great eagerness in condemning the opinions of the Protestants; but it was soon after dissolved. In this council, protracted through many years, the church of Rome increased, in the view of Protestants, instead of diminishing, every acknowledged evil. Nothing was altered; no error retracted; no compliance with the popular demand for reformation was made. 'This was the issue and aim of the Trent reformation,' remarks Richerus, 'that no respect should be had to truth, but to show and outward pomp only; and that all things should be referred to the splendor and profit of the Roman court.'

As the pope advanced in years he grew more strongly attached to his family, and more jealous of his authority; but, in the midst of the schemes for the aggrandisement of the latter, he died A. D. 1549, in the eighty-second year of his age, and after he had held the Roman see more than fifteen years. He was succeeded by Julius III., formerly known as John Maria Del Monte. One of his first acts gave great offence to every decent person; he conferred a cardinal's hat, with ample ecclesiastical revenues, upon a youth of sixteen, born of obscure parents, and known

by the name of Ape, from his having been entrusted with the care of an animal of that species in the cardinal Del Monte's family. When Julius was reproached by the cardinals for introducing such an unworthy member into the sacred college, a person who had neither learning, nor virtue, nor merit of any kind, he imprudently replied, by asking them, 'What virtue or merit they had found in him that could induce them to place him (Julius) in the papal chair?' Having also one day ordered a cold peacock for his supper, and not perceiving it on the table, he expressed his anger in a most horrible blasphemy. One of his cardinals remonstrating with his holiness on the violence of his passion, his reply was, 'If God could be so very angry about an apple, as to turn our first father out of paradise, why should it not be lawful for me, who am his vicar, to be in a passion for a peacock?' The subsequent conduct of Julius corresponded with his shameless behaviour at the commencement of his pontificate; and he died, lamented by none, in 1555, having held the papal see about five years. His successor was Marcellus II., who died within a month of his consecration.

Cardinal Caraffa, who took the name of Paul IV., was the next occupant of the papal throne. The Roman courtiers, from the known austerity of his character, anticipated a severe and violent pontificate. Paul, however, began his government by ordering his coronation to be conducted with greater pomp and ceremony than usual, and, when he was asked in what manner he chose to live, he haughtily replied, 'as becomes a great prince.' He used great pomp in his first consistory, when he allowed audience to the ambassadors of Mary, queen of England, who came to tender her obedience to the papal see, on which occasion he gave the title of a kingdom to Ireland. He maintained, with undiminished rigor, the pretensions of the church of Rome. When Sir Edward Ranne notified the accession of Elizabeth to this pope, he answered that England was held in fee of the apostolic see—that the queen could not succeed, being illegitimate—and that she was presumptuous, in assuming the crown; but that if she renounced her pretensions and, submitted her case entirely to him, he would do every thing, which, without his consent, could not be done consistently. 'He never talked,' says Father Paul, 'with ambassadors, without thundering in their ears that he was superior to all princes; that he would admit none of them on a footing of familiarity with himself; that it was in his power to change kingdoms, and that he was the successor of those who deposed kings and emperors.' Paul finally perfectly organized the inquisition.

Shortly after the pope was very desirous of convincing the world that he had sincerely at heart a correction of abuses; and with this view ordered all bishops to proceed to their own dioceses, and all who had embraced a monastic life to return to their monasteries. It was now almost too late, however, to act upon a new course of practice, and Paul was unable to remedy these evils, as he died in August 1559 in the eighty-fourth year of his age, after a pontifi-

cate of little more than four years. Pius IV., whose original name was John Angelo Di Medici, was chosen to succeed Paul, after a delay of more than four months. Soon after his accession he despatched a nuncio to England with secret instructions and a conciliatory letter; offering to annul the sentence against the marriage of Elizabeth's mother, to allow the use of the cup to the English, and to confirm the English liturgy: but Elizabeth had already decided on her course; and the nuncio was informed that he could not be permitted to set foot in England. Pius now issued a bull for reassembling of the council at Trent, which met in January 1562. Attempts were soon made to abridge the authority of the pope, which created in his holiness perpetual anxiety, and he was on the point of suddenly dissolving the assembly. In 1563 it was brought to an end, but not until decrees were passed, designed as an acknowledgment of the subordination of the council to the holy see. When information of the dissolution of the council was brought to Pius, he received it with great joy, and ordained a solemn thanksgiving on the occasion; and, in a very short time, he published a bull of confirmation, requiring all the prelates and princes to receive and enforce the decrees of the council, prohibiting persons from writing any explication or commentary of them; and commanding the catholics every where to have recourse, in all doubtful cases, to the apostolic see.

Pius IV. died in 1565, in the sixty-seventh year of his age, and after a pontificate of nearly six years. The news of the fact was received, it is said, with great joy by the Roman people on account of the severity and oppression of his government. His successor was cardinal Ghislieri, who took the title of Pius V., early displayed great zeal and diligence in promoting a reformation in the manner and morals of all ranks. He exhibited, however, a furious zeal against the Protestants, by persecuting them with the same savage severity which rendered him odious in his former character of inquisitor. He also incited Philip II. to attempt by war and massacre their extermination; and induced him to intrust the expedition designed for this purpose to the ferocious duke of Alva. In 1568 Pius published his famous bull, entitled *In Cænâ Domini*, which it was usual to publish at Rome on Maundy Thursday every year, till it was suppressed by pope Clement XIV. By this bull anathemas were pronounced against such persons as should appeal to general councils from the decrees of the popes; and against those princes who should impose restraints on ecclesiastical jurisdiction or exact contributions from the clergy. It was, however, never received in any kingdom out of Italy. He also issued a bull of excommunication against Elizabeth, queen of England, absolving her subjects from their allegiance. 'We declare her, out of the fulness of the apostolic power, to be a heretic, and a favorer of heretics: he said, we moreover declare her to be deprived of her pretended title to the kingdom aforesaid, and of all dominion, dignity, and privilege whatsoever; and also the nobility, subjects, and people of the said kingdom, and all who have in



any sort sworn unto her, to be for ever absolved from every such oath, and all manner of duty, of dominion, allegiance, and obedience. We also command and interdict all and every the noblemen, subjects, and people aforesaid that they presume not to obey her, or her monitions, mandates, and laws; and those who shall do to the contrary we do likewise anathematize.' (See Butler's Mem. l. 187). Pius was carried off by an attack of the stone in 1572, when he was about the age of sixty-eight, after a pontificate of little more than six years.

Gregory XIII. was unanimously elected his successor. It was during this pontificate that the massacre of the Protestants at Paris took place. See REFORMATION: 60,000 Protestants, according to Sully, fell in this awful massacre; and that it did not extend to the extermination of every individual, was, under divine providence, to be attributed to the caution of some who left the capital in time, the intrepidity of others, and the generous feeling of many of the Catholic officers, who refused to obey commands which they said belonged rather to executioners than to soldiers. This deed of blood was as assuredly approved by the pope as it was executed by the mandate of his priests. It was celebrated as an act of religion at Rome, and justified as a holy deed by the partisans of Rome. The solemn thanksgiving made was accompanied with a jubilee to all Christendom; for which one of the reasons was that they should thank God for the slaughter of the enemies of the church lately executed in France. In the oration of Muretus, pronounced in the presence of the supreme pontiff, Gregory XIII., that memorable night, in which this accursed slaughter was committed, is blessed. The king, the queen, and the royal family are extolled for their share in the transaction, and the pope himself is styled most blessed Father for going in procession, to return thanks to God and St. Louis for the welcome news when brought to him. After the death of Gregory, in 1585, the papal chair was filled by Sixtus V. (Felix Perretti Di Montalto), who in pride, magnificence, intrepidity, strength of mind, and in other great virtues and vices, surpassed most of his predecessors. It had been usual, for the sake of acquiring popularity, on the election of a new pope, to set the imprisoned criminals at liberty; but the first act of Sixtus was to order four persons to be hanged, on whom were found, a few days before, prohibited weapons. This system of rigor he pursued with the most inexorable severity, never, in a single instance, pardoning a criminal. Instead of censuring the assassination of Henry III., King of Navarre, by the dominican Clement, Sixtus commended and approved of the action in a long, public, and official oration. That a monk had slain a king in the midst of his people he considered 'Rarum insigne et memorabile facinus. Facinus non sine Dei optimi maximi particulari providentia, et dispositione.' And then he goes on to say that it was not only done with the special providence and appointment of God, but by the suggestions and assistance of his Holy Spirit; a greater work than Judith's slaying Holofernes. In 1588 Philip equipped his invincible armada;

and Sixtus seconded the enterprise with all spiritual authority. He renewed the bulls of Pius and Gregory against Elizabeth; and once more excommunicated and absolved her subjects from their allegiance. This celebrated pontiff died in August 1590, having reigned five years and four months. The rigor of his administration, his improvement of the city of Rome, the vast treasures he accumulated, his foundation of the Vatican library, and his fixing the number of cardinals at seventy, have all contributed to gain him immortal reputation, and have thrown great splendor about his name. Though we cannot look upon him as the model of a great prince, and much less of an irreproachable prelate, yet was his life and administration distinguished by many noble acts, particularly in his encouragement of sacred literature. In 1590 Sixtus published an edition of the Latin Vulgate, which by a bull he commanded should be received every where, and in all cases for true, legitimate, authentic, and undoubted; and that all future editions should be made conformable to this, not the least syllable being changed, added, or omitted, on pain of the greater excommunication. Notwithstanding this denunciation, however, Clement VIII., not very long after, revoked the decree of Sixtus, suppressed his edition, and published another of his own, in which he made more than 2000 corrections.

In 1592 the papal chair was filled by Hippolito Aldobrandini, under the name of Clement VIII. Clement yielded to none of his predecessors in zeal for the extension of the Romish faith; in this spirit he prepared the oath to be taken by the bishops and archbishops, which contains the words 'jura, honores, privilegia, et auctoritatem, Rom. ecclesie, domini nostri Papæ et successorum, conservare, defendere, augere, promoverè curatio; Hereticos, schismaticos, et rebelles eidem domini nostro, pro posse persequar.' (Pont. Rom. Clem. VIII. Antwerp 1627, p. 59). In 1600 Clement issued a bull to prevent James I. from ascending the throne of England, declaring that 'when it should happen that that miserable woman (queen Elizabeth) should die, they (her subjects) should admit none to the crown, though ever so nearly allied to it by blood, except they would not only tolerate the Catholic religion, but promote it to the utmost of their power, and would, according to ancient custom, undertake upon oath to perform the same.' He was succeeded in the year 1605 by Leo XI. of the house of Medicis, who died a few weeks after his election, and thus left the papal chair open to Camillo Borghese, by whom it was filled under the denomination of Paul V. No one of his predecessors exceeded this pontiff in zeal for advancing the ecclesiastical authority, or showed himself more violent in endeavouring to execute his vengeance upon such as encroached upon his prerogative. Paul died at Rome in January 1621, in the sixty-ninth year of his age, after a pontificate of nearly sixteen years. Gregory XV., who was raised to the pontificate in 1621, seemed to be of a milder disposition, though he was not less defective in equity and clemency towards those who had separated themselves from the church. This pope instituted the fa-

mous college, 'De propaganda fide,' and endowed it with ample revenues for the maintenance of persons to be educated for foreign mission. Urban VIII., who previously bore the name of Maffei Barberini, and who, by his interest in the conclave, succeeded Gregory in the papal throne in 1623, was a man of letters, an eloquent writer, an elegant poet, and a generous and munificent patron of learning and genius; but nothing can equal the rigor and barbarity with which he treated all who bore the name of Protestants. The Bull, *In cænâ Domini*, written in 1610 by Paul V., and promulgated by Urban in 1627, contains the whole elixir of ultramontane orthodoxy. It excommunicates heretics, schismatics, &c.; all who dare to appeal to a future council against the bulls and briefs of the pope; all princes who dare to levy taxes without the permission of the pope; those who make treaties of alliance with Turks or heretics; and those who complain to the secular judges against the wrongs and injuries received from the court of Rome.

In 1643 he issued a bull of deposition against Charles I. in Ireland: where, two years before, not fewer than 100,000 Protestants were massacred, and to those who had joined the rebellion of 1641 the same holy pontiff granted a plenary indulgence. In this dreadful massacre, as in that of France on St. Bartholomew's day, no ties of nature or of friendship could prevent the papists from imbruing their hands in the blood of their nearest Protestant relations. He may however be considered as a good and equitable ruler, compared with Innocent X., of the family of Pamphili, who succeeded him in the year 1644. This unworthy pontiff, of a profound ignorance, joined the most shameful indolence and the most notorious profligacy; for he abandoned his person, his dignity, the administration of his temporal affairs, and the government of the church, to the disposal of Donna Olympia, a woman of corrupt morals, insatiable avarice, and boundless ambition. He was succeeded in the papal chair, in the year 1655, by Fabio Chigi, who assumed the title of Alexander VII., and who, though less odious than his predecessor, nevertheless possessed all the pernicious qualities that are necessary to constitute a true pope, and without which the papal jurisdiction and majesty cannot be maintained. Benedict Odeschalchi, who is known in the list of pontiffs by the denomination of Innocent XI., and was raised to that high dignity in the year 1677, began his high career with abolishing abuses, and suppressing many gross superstitions then prevailing in the church of Rome. This respectable pontiff acquired a very high and permanent reputation by the austerity of his morals, his uncommon courage and resolution, his dislike of the grosser superstitions that reigned in the Romish church, his attempts to reform the manners of the clergy, and to abolish a number of those fictions and frauds that dishonor their ministry, and also by other solid and eminent virtues. He had a contest with the French king about the right of disposing of benefices and church lands, claimed by that monarch, and confirmed to him by an assembly of the clergy, which nearly terminated in a

VOL. XVIII.

separation of the Gallican church from the Roman communion. It was on this occasion that Louis summoned the famous assembly of bishops which met at Paris in the year 1682, and drew up the four celebrated propositions declaring the power of the pope to be merely spiritual and inferior to that of a general council, and maintaining the inviolability of the rules, institutions, and observances of the Gallican church. These propositions were to the following purport:—1. That neither St. Peter nor his successors have received from God any power to interfere, directly or indirectly, in what concerns the temporal interest of princes and sovereign states; that kings and princes cannot be deposed by ecclesiastical authority, nor their subjects freed from the sacred obligation of fidelity and allegiance, by the power of the church or the bulls of the Roman pontiff. 2. That the decrees of the council of Constance, which maintained the authority of general councils as superior to that of the popes in spiritual matters, are approved and adopted by the Gallican church. 3. That the rules, customs, institutions, and observances which have been received in the Gallican church are to be preserved inviolable. 4. That the decisions of the pope, in points of faith, are not infallible, unless they be attended with the consent of the church.

Innocent died in 1689, having presided over the Roman see twelve years and a half. During this pontificate Louis XIV. was induced to revoke the edict of Nantz. On occasion of this disgraceful act Bossuet breaks out—'Let me indulge the movement of my heart, and dwell on the piety of our monarch; let me address this new Constantine, this new Theodosius, this other Marcian, this other Charlemagne, in the words with which the 630 fathers expressed their sentiments to the emperor at the council of Chalcedon:—'You have strengthened the faith, you have exterminated the heretics; it is the most meritorious act of your reign. King of Heaven! preserve the king of the earth! It is the ardent desire of the church; it is the ardent desire of the assembly, of her pastors, and of her bishops.' Innocent XII., a man of uncommon merit and eminent talents, whose name was Pignatelli, and who, in the year 1691, succeeded to the papal chair, was unwearied in his endeavours to reform the corrupt manners of the clergy, though he found that the entire accomplishment of the Herculean task was a consummation which all his prudence and resolution were unable to effect. He was anxiously devoted to the interests of the poor, and the wealth which many of his predecessors had been accustomed to accumulate, or to bestow on worthless relatives, he devoted to the public benefit, employing it in the erection of hospitals and other useful institutions. Innocent died in the year 1700 at the advanced age of eighty-five, after presiding over the church about nine years. The corruptions that had been complained of in preceding ages, both in the higher and inferior orders of the Romish clergy, were rather increased than diminished during this century, as the most impartial writers of that communion candidly confess. The bishops were rarely indebted for their elevation to their eminent learning, or

2 X

superior merit. The intercession of potent patrons, services rendered to men in power, connexions of blood, and simoniacal practices were, generally speaking, the steps to preferment; and, what was still more deplorable, their promotion was sometimes owing to their vices. Their lives were such as might be expected from persons who had risen in the church by such unseemly means; for had they been obliged, by their profession, to give public examples of those vices which the holy laws of the Gospel so solemnly and expressly condemn, instead of exhibiting patterns of sanctity and virtue to their flock, they could not have conducted themselves otherwise than they did. Some indeed there were who, sensible of the obligations of their profession, displayed a truly Christian zeal in administering useful instruction, and exhibiting pious examples to their flock, and exerting their utmost vigor and activity in opposing the vices of the sacred order in particular, and the licentiousness of the times in general. But these rare patrons of virtue and piety were either ruined by the resentment and stratagems of their envious and exasperated brethren; or were left in obscurity, without that encouragement and support which were requisite to enable them to execute effectually their pious and laudable purposes.

Clement XI., originally John Francis Albani, was chosen to succeed Innocent in the pontifical office. He redressed some grievances, discountenanced vice and criminality of every kind, performed acts of beneficence, gave an example of devotional regularity, and filled vacant offices and preferments with men of merit. But a revival of the contest between the Jansenists and the Jesuits had for some time conspired with politics and wars to disturb the tranquillity of Rome. For the more effectual repression of Jansenism, a new apostolical constitution was issued in the year 1705, condemning such errors with menaces of papal indignation. The anti-Jansenist ordinance, as it commenced with the terms *unigenitus Dei filius*, was quickly known throughout Christendom by the appellation of the bull 'unigenitus.' This bull put an end to all hope of a reconciliation between the church of Rome and the Protestants, as in most of those points which had occasioned the separation it represented the doctrines of that church in the very same light in which they had been regarded by the first reformers. This bull is also known by the name of the constitution.

The dissensions and tumults excited in France by this edict were violent in the highest degree. A considerable number of bishops, and a large body composed of persons eminently distinguished by their piety and erudition, both among the clergy and laity, appealed to a general council. It was more particularly opposed by the cardinal de Noailles, archbishop of Paris, who, equally unmoved by the authority of the pontiff and by the resentment and indignation of Louis XIV., made a noble stand against the despotic proceedings of the court of Rome. The issue of this famous contest was favorable to the bull, which was at length rendered valid by the authority of the parliament, and was registered among the laws of the state. This contributed, in some

measure, to restore the public tranquillity; but it was far from diminishing the number of those who complained of the despotism of the pontiff. In 1712, when by virtue of the treaty of Altrastadt certain places were to be surrendered to some Protestant princes, pope Clement XI., in a letter to the emperor Charles VI., denounced the Protestants as 'an execrable sect,' and, in the plenitude of his pretended supremacy, declared every thing which either was, or could be construed or esteemed to be, in any way, obtrusive of, or in the least degree prejudicial to, the Romish faith or worship, or to the authority, jurisdiction, or any rights of the church whatever, 'to be, and to have been, and perpetually to remain hereafter, null, unjust, reprobated, void, and evacuated of all force from the beginning: and that no person is bound to the observance of them, although the same have been repeated, ratified, or secured by oath.' Clement died in 1721, at the age of seventy-one. The election of Michael Angelo Conti, who took the name of Innocent XIII., as successor of Clement, was very unexpected. His noble descent and his personal accomplishments had raised him to the highest offices, the duties of which he had always discharged with reputation and honor. But the infirmities of age prevented him from distinguishing himself as pope. Innocent died the 3d of March 1724. Cardinal Vincent Orsini, eldest son of the duke of Gravina, who now succeeded to the pontificate as Benedict XIII., took every opportunity of recommending a strict regard to moral and social duties, and a steady practice of Christian virtues. His dislike of pomp and magnificence, his concern for the morals of the clergy, and his care for the poor, however commendable, did not obtain for him or his plan the support of the cardinals and the other great men of his court. He held a provincial council in the Lateran church, chiefly for a reform of the conduct of the clergy; and the assembly voted for an enforcement of some decrees that had been enacted by the council of Trent, but which had fallen into disuse. On another occasion he rose above the bigotry of his predecessors, by expressing a wish for the diffusion of scriptural knowledge; and, with that view, he permitted the people in general to peruse the sacred volume, and encouraged the multiplication of copies in the modern languages. A grand scheme of religious comprehension was formed by this respectable ruler of the Romish church: it was of no less magnitude than the union of the four communities that divided Christendom. He proposed that four councils should be holden at different places at the same time, each consisting of a certain number of representatives of the Romish, Greek, Lutheran, and Calvinist churches, with a president of one or other church in each assembly. He did not, however, carry his scheme into execution. Benedict was indefatigable in his official duties: he continued to pray and preach, attend to all pontifical and sacerdotal functions, and direct the conduct of subordinate prelates and ministers of the church. He frequently visited the poor, and relieved them by his bounty, selling for that purpose the presents which he received. He habituated him-

self to the plainest fare, and lived in the most frugal manner, like a hermit in his cell, that he might more liberally bestow upon others the blessings of fortune. He died in the eighty-second year of his age and the sixth of his pontificate. Yet so overpowering were the principles of his church over the mind of this naturally moderate and well disposed man that, from evidence communicated to a committee of the Irish parliament by father John Kenney, it appears that his holiness, in compliance with the request of the Romish archbishops and bishops of Ireland (who had conspired with others of the Romish communion to place the pretender on the throne), issued his bull to facilitate their intention, and sent them an indulgence for ten years, in order to raise a sum of money, to be speedily applied to restore James III. This bull provided that every communicant, confessing and receiving upon the patron days of every respective parish, and any Sunday from the 1st of May to September, having repeated the Lord's prayer five times, and once the apostles' creed, upon paying two pence each time, was to have a plenary indulgence for all his sins. And, under this bull, it appears that the sum of £1500 sterling was ready to be remitted to the pretender's agent in Flanders, at the time the treasonable conspiracy was detected by the vigilance of the Irish government! Clement XII., of the Corsini family, was now chosen in 1730, after a long contest, to succeed the mild and humble Benedict. He quickly reformed some abuses which had crept into the administration of the Roman state, and then directed his attention to foreign affairs. This pontiff was a man of respectable abilities; had a regard for justice; was cautious and prudent, yet not destitute of spirit; economical without being meanly parsimonious; easy of access, without rendering himself indecorously familiar. He had a taste for the polite arts, and was an encourager of literary merit. Dying in February, 1740, in the eighty-eighth year of his age, he was succeeded by Prosper Laurence Lambertini, archbishop of Bologna, who entered upon his high office under the designation of Benedict XIV.

In the administration of the church, Benedict was mild and conciliatory. He was aware of the relaxed morality of the clergy in the catholic states; but, however he might wish to check their licentiousness, he did not take any strong or violent measures for that purpose. At the solicitation of those princes who were displeased at the intrigues and offended at the mal-practices of the Jesuits, he promised to exert his authority for the reform of that order, and the bull which he issued for this purpose was one of the last acts of his life. He died in 1758, when he had attained the age of eighty-three years. He was an erudite theologian, as his numerous works evince, and a liberal patron of learning and the arts. Cardinal Rezzonico, bishop of Padua, who succeeded him as Clement XIII., had a greater reputation for piety, and was more zealous for the high claims of the church, but he was not so generally esteemed as his predecessor. During his pontificate the Jesuits became peculiarly obnoxious. Their enemies in vain so-

lited the dissolution of that order while Clement filled the papal chair; but they conceived strong hopes of success when a prelate of a more philosophical character was chosen pontiff. This was a Franciscan monk, Francis Lawrence Ganganelli, who obtained the purple in the year 1769, and thought proper to assume the name of his immediate predecessor. The Jesuits affected to believe (and probably many of them really thought) that Clement would not dare to suppress their order. But, in the fifth year of his pontificate, a bull for the annihilation of the society was promulgated, its colleges were seized, and its revenues confiscated. Lorenzo Ricci, the refractory general of the order, was sent to the castle of St. Angelo, and died in confinement. The French complimented Ganganelli on this occasion by restoring the Venaissin to the holy see. In 1775 Clement published a bull of indulgence, which fully proves that this spiritual traffic was as yet officially and publicly recognised by the church of Rome. Clement did not long enjoy his tranquillity; for he died in the autumn of the following year at the age of sixty-eight. It was supposed that he had been poisoned, but this suspicion has not been verified. Of all the occupants of the papal throne, for some centuries, Ganganelli seems to be one of the most unprejudiced, candid, and liberal.

The government of the church after his death was consigned to John Angelo Braschi, who had been created cardinal by Ganganelli, and was regarded as a moderate man. He commenced his administration as Pius VI. with acts of benevolence and charity, and with the selection of deserving men for various offices. He also issued a bull, dated April 1778, in which he declared that 'the faithful should be excited to the reading of the Holy Scriptures, for these are the most abundant sources which ought to be left open to every one, to draw from them purity of morals and of doctrine.' At this time the emperor Joseph of Austria, who was himself a freethinker, manifested a strong inclination to abridge the papal power in his dominions. In 1781 he began with imposing restrictions upon the operations of bulls and rescripts sent from Rome. He further displeased the pontiff by ordering that no money should be sent into foreign countries for masses; that no dignity should be solicited at Rome without his permission; that pilgrimages should be discontinued; and that the number of images and ornaments in churches should be diminished. The disgust felt by Pius at this conduct was not allayed by the liberal edict of Joseph, granting full toleration to all the Protestants in his dominions, as well as to all members of the Greek church: the dissolution of a great number of monasteries, with the conversion of the buildings into colleges, hospitals, or barracks, increased the indignation of the pope. The see of Rome lost in consequence the presentation to bishoprics in Lombardy and other Austrian dependencies; its nuncios were deprived of their power and jurisdiction in Germany, and the lustre of the papacy was visibly eclipsed.

There seemed to be a general disposition in Catholic Europe, during this pontificate, to diminish the authority of the papal see; so that

the modern bishops of Rome exhibit little more than an empty shadow of the authority of the ancient pontiffs. The sovereign princes and states of Europe who embrace their communion no longer tremble at the thunder of the Vatican, but treat their anathemas with indifference. They indeed load the holy father with pompous titles, and treat him with all the external marks of veneration; yet they have given a mortal blow to his authority, by the prudent and artful distinction they make between the court of Rome and the Roman pontiff. For, under the cover of this distinction, they buffet him with one hand and salute him with the other. In 1796, when Buonaparte was every where victorious, Pius committed an act of aggression by suffering the Neapolitan cavalry who were hastening to the succor of the enemies of France to pass through the territories of the church, and even directed their march. When the pontiff was under the necessity of throwing himself on the clemency of the conqueror, he would not even grant him an armistice but on very severe conditions. The pope was compelled to renounce the friendship of the coalesced powers, and to shut up his ports against them; to surrender to the French the cities of which they already had possession, as well as the citadel of Ancona; to pay nearly £1,000,000 sterling; and to deliver 100 pictures, busts, vases, statues, &c., and 500 MSS., to be selected by commissioners who should be sent to Rome for that purpose. Europe beheld with astonishment and regret this pontiff, a venerable old man, degraded, insulted, expelled from his capital, and harassed with removals from place to place. During his pontificate he is said to have deserved, by his good government and public spirit, the respect and affection of his subjects. Pius died at Briançon, in April 1799, in the eighty-second year of his age.

After the church had subsisted for some time without a head, the fugitive members of the sacred college held a conclave at Venice, by desire of the emperor of Germany: and the cardinal Di Chiaramonte, being honored with their suffrages, began to act as pontiff under the title of Pius VII. Immediately on his election he announced his succession to Louis XVIII. as the lawful king of France, though then in exile: yet, in the following year, he entered into a concordat with Buonaparte. Rome being recovered by the arms of the allies, Pius was soon enabled to unite temporal power with spiritual authority. With him, therefore, Buonaparte condescended to treat; when this fortunate warrior, having acquired the dignity of first consul or sovereign of France, wished to show himself a friend to religion. It was stipulated between them that the catholic, apostolic, and Romish religion, should be freely and publicly exercised in France; that a new division of dioceses should take place: that, as soon as the first consul should have nominated bishops, the pope should confer upon them the canonical institution; that the prelates should appoint, for parochial ministers, such persons as the consul should approve: that no council or synod should meet without the consent of the government; that no papal legate or nuncio should act, and no bull or brief be opera-

tive without the same consent. Ten archbishops and fifty bishops were assigned to the whole republic; and it was required that they should be natives of France, aged at least thirty years. The subserviency of ecclesiastics of all descriptions to the civil power, in doctrine as well as in discipline, formed a leading feature in this arrangement. The secularization of certain German churches and chapters in 1803, by the diet of Augsburg, which distributed some of them as indemnities to secular Protestant princes, gave occasion to many despatches from Rome in the years 1803, 1804, and 1805, and particularly to an instruction to the papal nuncio resident at Vienna in 1805, in which Pius VII. says, that the church had not only taken care to prohibit heretics from confiscating ecclesiastical possessions; but that she had moreover established, as the penalty of the crime of heresy, the confiscation and loss of all property possessed by heretics. This penalty, as far as concerns the property of private individuals, is decreed, he says, by a bull of Innocent III. cap. Vergentes X. de Hæreticis: and, as far as concerns sovereignties and fiefs, it is a rule of the canon law, cap. Absolutus XVI. de Hæreticis, that the subjects of a prince manifestly heretical are released from all obligation to him, dispensed from all allegiance and all homage. To be sure, his holiness goes on to say, we are fallen into such calamitous times that it is not possible for the spouse of Jesus Christ to practice, nor even expedient for her to recal her holy maxims of just rigor against the enemies of the faith. But, although she cannot exercise her right of deposing heretics from their principalities and declaring them deprived of their property, yet can she not for one moment allow that they should rob her of her property to aggrandise and enrich themselves! What an object of derision would she become to heretics and infidels, who, in mocking her grief, would say, that they had found out a way of making her tolerant! *Essai Historique sur la Puissance Temporale des Papes.* tom. II. p. 320.

The church, however, was destined to be dealt with on very different principles by one of her 'dear sons.' Early in 1809, while Buonaparte was at Vienna, he caused proclamation to be made in the public squares and market place of that city, that from the 1st of June the papal territory should be united with the French empire; and that Rome should at the same time be declared a free and imperial city. This decree, which fixed the annual revenue of the pope at 2,000,000 of francs, was grounded on three propositions: first, that the territories of Rome were fiefs bestowed by the emperor Charlemagne, the predecessor of the emperor Napoleon, on the bishops of Rome, to maintain the peace of his subjects; second, that ever since that time the union of temporal and spiritual power had been, and still is, the source of dissension; and third, that the temporal pretensions of the pope are irreconcilable with the security of the French army, the repose and prosperity of the nations subject to the sway of Napoleon, and the dignity and inviolability of his empire. The pope protested against this violence, excommunicating Buonaparte and all who adhered to him in his invasion of the papal

states, but all without effect; though he continued to exercise the functions of his office without further interruption, but with little opportunity for energetic conduct, till the subversion of the Napoleon dynasty, when he resumed the full possession of his authority. In his proclamation issued at Cezena on the 5th of May, previously to his return to Rome, his holiness applied to himself the ancient title of God's vicar on earth, and spoke of his temporal sovereignty as essentially connected with his spiritual supremacy.

The papal see, after enjoying a short tranquillity, was visited with repeated shocks in the revolutions of Spain, Portugal, and Naples. With respect to these events, particularly the latter, Pius acted a cautious part. Fearing probably that the aroused energies of these nations would involve the papacy in new difficulties, he declared the states of the church open to the passage of all friendly troops; but denouncing, in the strongest terms, the disorderly and factious. The constitutional government of Naples, which gave the pope the greatest cause for uneasiness, was, however, overturned by the power of Austria; and the invasion of Spain, by the armies of France, succeeded for a time in re-establishing Romish tyranny and superstition in the whole of the peninsula. The subdued countries, however, present an appearance which promises anything rather than continued repose. Pius VII. died August 20, 1823, and was succeeded by Leo XII.

PART II.

DOCTRINES OF THE ROMAN CATHOLICS.

Thus have we traced historically the rise, progress, and comparative decline, of this great domination: the writer as a Protestant, and a Protestant clergyman, will, in the estimation of Catholic readers, perhaps, seem unduly biassed, and occasionally to display the advocate. Recollecting how large a portion of his countrymen are Catholics, the editor, therefore, thinks it fair to subjoin without comment the last authentic compendium of the principles of their church in the Declaration of the English Catholic bishops, dated May, 1826. It must only be understood that the Catholics now speak for themselves.

DECLARATION OF THE CATHOLIC BISHOPS, THE VICARS APOSTOLIC, AND THEIR COADJUTORS, IN GREAT BRITAIN.

I. *On the general character of the doctrines of faith professed by the Catholic church.*—The doctrines of the Catholic church are often characterised as erroneous, unscriptural, and unreasonable. All those doctrines, and only those doctrines, are articles of Catholic faith, which are revealed by Almighty God. Whatsoever is revealed by God, who knows all things as they are in themselves, and who cannot deceive us by teaching falsehood for truth, is most true and certain; though it may entirely surpass the comprehension of created minds.

On the authority of divine revelation, the Catholic believes, as doctrines of faith, that in one God there are three distinct persons, the Father, the Son, and the Holy Ghost; that

Jesus Christ, who died on the cross for the salvation of all mankind, is the second person of the Blessed Trinity, true God and true man; that there is no remission of sin, nor salvation, but through him; that the sacraments of baptism and penance are divinely appointed means for the remission of sin; that in the mass a true, proper, and propitiatory sacrifice is offered to God for the living and the dead; that the souls detained in purgatory are helped by the suffrages of the faithful; that the saints reigning together with Christ are to be honored and invoked; that at the last day our bodies will be raised from death, and that Christ will come to judge all men according to their works; that eternal happiness will be the reward of the good, and eternal misery the punishment of the wicked. If these, and other doctrines of Catholic faith, are really revealed by Almighty God, they are not erroneous, but most true and certain—they are not unscriptural, but agreeable to the true sense of the written word of God—the belief of them is not unreasonable, because it is reasonable to believe whatever is true, and taught by the God of truth. The Catholic is fully persuaded that all the articles of his faith are really revealed by Almighty God. Is he not at liberty to think so, as well as others are to think the contrary; and in this empire especially, where liberty of thought is so loudly proclaimed and lauded? Is it reasonable or charitable to condemn him for thinking so, when he may have good and solid grounds for his conviction, and may feel that his eternal salvation depends on his firm belief of all the doctrines which Christ has taught?

II. *On the grounds of the certitude which a Catholic has that all the doctrines which he believes, as articles of Catholic faith, are really revealed by Almighty God.*—Catholics are often charged with grounding their faith on mere human authority, and not on the word of God. Catholics deny this, because they are convinced, that their faith is grounded on the word of God, proposed to them by the authority of that ministry, which Christ established, and appointed to teach his revealed doctrines to all nations.

The Catholic believes all those doctrines which God has revealed. The question, what are those doctrines which God has revealed, is a question of fact. It appears reasonable that the existence of a fact should be ascertained by the evidence of testimony.

The body of the doctrines, precepts, and institutions, which were delivered by Christ to his apostles, constitutes the new or the Christian law; as the body of the doctrines, precepts, and institutions, which were delivered by the Almighty to Moses, constituted the old law. The true and certain knowledge of what is commanded by any law is generally communicated and obtained by the authoritative promulgation of the law. By the ordinance of God, the doctrines and precepts of the old law were made known to the Israelites and Jewish people, by Moses, and the priests in succession, till the end of the law. By the ordinance of God, the doctrines and precepts of the new law were to be made known to all nations, in all ages, by the

apostles and their successors, to the consummation of the world.

On the spiritual authority of the apostles and their successors, who were divinely commissioned to promulgate and teach the law of Christ to all nations; and on the uniform and universal testimony, belief, and practice of all Christian churches from the beginning, the certitude of the Catholic is grounded, that all the doctrines which he believes as articles of Catholic faith, and all the sacred precepts and rites which he observes as the ordinances of Christ, were really revealed and instituted by Almighty God; and are the same as were originally delivered by Christ to his apostles, and by them promulgated over all nations.

The Catholic is fully satisfied that this method which he follows, for ascertaining what are the revealed doctrines of divine faith, is the right rule, and that it leads him to the unity of truth. Is he not at liberty to follow a rule which gives such satisfaction and security to his mind? Is it fair for others who, by following a different rule, are led into a countless variety of contradictory doctrines on matters of Christian belief, to disturb the tranquillity of the Catholic on this head, or to condemn him for his submission to the authority of a ministry which he is convinced was established by Christ for the purpose of bringing all nations to the certain knowledge of his law, and to the unity of faith? Is not this rule perfectly natural and reasonable? Can any human legislator condemn the principle and rule of the Catholic in this regard?

III. *On the Holy Scriptures.*—In England the Catholic church is held out as an enemy to the reading and circulating of the Holy Scriptures. Whereas the Catholic church venerates the Holy Scriptures as the written part of the word of God; she has in all ages been the faithful guardian of this sacred deposit; she has ever labored to preserve the integrity of these inspired writings, and the true sense, in which they have been universally understood, at all times from the apostolic age.

The Catholic church has never forbidden or discouraged the reading or the circulation of authentic copies of the sacred Scriptures, in the original languages. She binds her clergy to the daily recital of a canonical office, which comprises a large portion of the sacred volume, and to read and expound to the faithful, in the vernacular tongue, on Sundays, the epistle or gospel of the day, or some other portion of the divine law.

As to translations of the Holy Scriptures into modern languages, the Catholic church requires that none should be put into the hands of the faithful but such as are acknowledged by ecclesiastical authority to be accurate, and conformable to the sense of the originals. There never was a general law of the Catholic church prohibiting the reading of authorised translations of the Scriptures; but, considering that many, by their ignorance and evil dispositions, have perverted the meaning of the sacred text to their own destruction, the Catholic church has thought it prudent to make a regulation that the faithful should be guided in this matter by the advice of their respective pastors.

Whether the Holy Scriptures, which ought never to be taken in hand but with respect, should be made a class-book for children, is a matter of religious and prudential consideration, on which the pastors of the Catholic church have a right to decide with regard to their own flocks; and we hold that in this matter none have a right to dictate to them. The Catholics in England, of mature years, have permission to read authentic and approved translations of the Holy Scriptures, with explanatory notes; and are exhorted to read them in the spirit of piety, humility, and obedience.

Pope Pius VII., in a rescript dated April 18th, 1820, and addressed to the Vicars Apostolic in England, earnestly exhorts them to confirm the people committed to their spiritual care, in faith and good works; and, for that end, to encourage them to read books of pious instruction, and particularly the Holy Scriptures, in translations approved by ecclesiastical authority; because, to those who are well disposed, nothing can be more useful, more consoling, or more animating, than the reading of the sacred Scriptures, understood in their true sense—they serve to confirm the faith, to support the hope, and to inflame the charity of the true Christian.

But when the reading and the circulation of the Scriptures are urged and recommended as the entire rule of faith, as the sole means by which men are to be brought to the certain and specific knowledge of the doctrines, precepts, and institutions of Christ; and when the Scriptures so read and circulated are left to the interpretation and private judgment of each individual: then such reading, circulation, and interpretation, are forbidden by the Catholic church, because the Catholic church knows that the circulation of the Scriptures, and the interpretation of them by each one's private judgment, was not the means ordained by Christ for the communication of the true knowledge of his law to all nations—she knows that Christianity was established in many countries before one book of the New Testament was written—that it was not by means of the Scriptures that the apostles and their successors converted nations, or any one nation to the unity of the Christian faith—that the unauthorised reading and circulation of the Scriptures, and the interpretation of them by private judgment, are calculated to lead men to contradictory doctrines on the primary articles of Christian belief; to inconsistent forms of worship, which cannot all be constituent parts of the uniform and sublime system of Christianity; to errors and fanaticism in religion, and to seditions and the greatest disorders in states and kingdoms.

IV. *On the charge of idolatry and superstition.*—Ignorance or malice has gone so far as to charge the Catholic church with idolatry, in the sacrifice of the mass—in the adoration (as it is called) of the Virgin Mary, and in the worship of the saints, and of the images of Christ and of the saints; and with superstition, in invoking the saints, and in praying for souls in purgatory. Now idolatry consists in giving to any creature that supreme adoration, honor, or worship, which is due only to Almighty God. The

Catholic church teaches that idolatry is one of the greatest crimes that can be committed against the majesty of God: and every true member of this church shudders at the idea of such a crime, and feels grievously injured by so horrid an imputation.

But it is said that Catholics adore the elements of bread and wine in the mass: that they adore the Virgin Mary; that they adore the cross; and that they worship the saints and the images of Christ and of the saints. Before we repel these horrid imputations, in the sense in which they are made, we must explain the different meanings of the words adoration, honor, and worship, that the calumnious charge, and its denial, may be understood in the same explained sense.

We find that in the language of the sacred Scripture, in Hebrew, Greek, and Latin,\* as well as in the language of the ancient liturgies of the Christian church, these words, adoration, honor, and worship, are ambiguous terms, and are used in different senses, according to the nature of the object to which the act, implied by the term, is directed, and according to the intention of him who performs the act. Hence we find them used as relating sometimes to God, and sometimes to creatures. Although, in modern times, the exclusive idea of that supreme homage, which is due only to God, is attached by some to the words adoration and worship; yet these words may still be retained by others, in a different meaning, without affording the remotest cause for the imputation of idolatry. In this different meaning they are still retained, in the unchanged language of the ancient liturgies used in the Catholic church.

The words adoration and worship are equally referred sometimes to God, and sometimes to creatures, as is the word honor. Now because we are commanded in Scripture to honor God, and to honor the king; and children are commanded to honor their parents: it does not follow that the honor due to the king, or to parents, is the same as that which we owe to God. To God we owe supreme and sovereign honor, such as it would be a crime to pay to any creature. To the king we owe the highest civil honor. To parents children owe the honor of filial respect and obedience. How unjust would it be to say that, because a subject honors his king, he pays him that supreme and sovereign honor which is due only to God! The same is to be said of the terms adoration and worship, as used in former times, and sometimes used at present in the language of the Catholic church. To adore, even according to modern usage, often means no more than to express extreme affection or respect. To worship (in the translation of the Bible, published at Oxford) is therein used to signify inferior as well as supreme worship. In the first book of Chronicles xxix. 20, we read in that edition, that the assembly bowed

down their heads and worshipped the Lord (Jehovah) and the king. Did they worship the king with the same supreme worship which they paid to God? Certainly not. When a man says, to the woman he takes to wife, 'with my body I thee worship,' can this be called idolatry? Surely nothing can be more unfair than arguments drawn from ambiguous terms, construed in a sense disavowed by those against whom the arguments are employed.

We answer therefore that, if by the terms adoration, honor, and worship, be understood that supreme adoration, honor, and worship which is due only to God; Catholics do not adore, nor honor, nor worship any other than the one, only, true, and living God, the Creator and Sovereign Lord of the universe: they do not, in this sense, adore, nor honor, nor worship the Virgin Mary, nor any of the saints, nor the cross, nor images, nor any other creature whatsoever.

In the mass, Catholics do offer supreme adoration, not to the elements of bread and wine, which they hold not to be present after the consecration; but to Jesus Christ, the Son of God, whom they believe to be truly, really, and substantially present, under the appearances only of bread and wine, after the consecration, and change thereby of the elements into his body and blood. To adore Christ, by an act of supreme adoration, is no idolatry; because he is truly God, and consequently a legitimate object of supreme worship.

But if Catholics, using the ancient language of the Christian church, are said, 1st. To worship the saints; this worship must be understood to be only an inferior worship, honor, and respect, paid to them proportionate to the limited perfections and excellences which God has bestowed upon them; but this worship is infinitely below that supreme worship which they pay to God. Catholics acknowledge no perfection or excellence in any saint, not even in the Blessed Virgin Mary, which they do not profess to be the work and gift of God in them. So that, in honoring the saints, they celebrate the works of God, and consequently give glory to him. Whatever act of religious veneration we pay to the saints is ultimately referred to God. 2nd. To adore the cross: this word, if applied to the cross itself, means no more than an inferior and relative respect paid to the instrument of our redemption; but if in view of the cross it be applied to Christ himself, then it means, as it ought to mean, an act of supreme adoration. 3d. To worship the images of Christ or of the saints: the word is here again understood by Catholics only of an inferior and relative respect shown to images, in consideration of the respect due to the objects which they represent, and to which the respect shown to the images is referred. In this sense respect shown to the statue or to the throne of the king, in consideration of the majesty of the personage to whom they relate. An insult offered to his statue would be considered as intended to be offered to the king himself. In this sense a son respects the image or picture of his parent; a parent that of his child; a friend that of his

\* See in Hebrew (Prov. iii. 9, and Exod. xx. 12), (Dent. xxviii. 47, and 48), (Ps. xcvi. 9 and 1, alias 3d Kings i. 23). In Greek, Gen. xxiv. 26, and Gen. xlix. 8. In Latin Adorare, Ps. xxviii. 2, and Gen. xxiii. 7, and 4th alias 2 Kings ii. 15.



friend; not for any intrinsic virtue in the material substance or work of art, but because it relates to, and brings to his mind, the object of his respect and affection.

To condemn this relative regard for images, or pictures, would be to condemn the very feelings of nature. To charge the Catholic with idolatry, because the term worship, meaning only an inferior and relative regard, is found in the ancient and modern liturgies of his church, is not consistent with candor or charity. The charge that the Catholic church sanctions the praying to images is a calumny, and carries with it an imputation of stupidity too gross to be noticed. Catholics sometimes pray before images, because they serve to collect their thoughts, and fix their attention in their meditations and prayers; but they are not, on that account, to be supposed to be so void of reason and sense as to pray to the image: for they know that in it there is no virtue or power; and that it can neither see, nor hear, nor help them.

Catholics do solicit the intercession of the angels and saints reigning with Christ in heaven. But in this, when done according to the principles and spirit of the Catholic church, there is nothing of superstition, nothing which is not consistent with true piety. For the Catholic church teaches her children not to pray to the saints, as to the authors or givers of divine grace; but only to solicit the saints in heaven to pray for them, in the same sense as St. Paul desired the faithful on earth to pray for him.

Catholics, according to the faith and pious practice of the Christian church from the age of the apostles, do pray for the release and eternal rest of departed souls, who may be detained for a time in a state of punishment on account of their sins, but in this we cannot discover even the shadow of superstition. By invoking the intercession of the saints in heaven, and by praying for the suffering souls in purgatory, Catholics exercise acts of that communion of charity which subsists between the members of the mystical body of Christ: the principle of which communion they profess to believe, when they say, 'I believe the holy Catholic church, the communion of saints.'

After this explanation and declaration, we hope that our countrymen will never be so unjust or so uncharitable as to charge Catholics with idolatry or superstition, nor be so illiberal as to attempt to give a color to these injurious charges, by fixing an exclusive meaning to terms, which in the language of Scripture, Christian antiquity, and common usage, bear different senses, in different circumstances.

V. *On the power of forgiving sins, and the precept of confession.*—The Catholic church is charged with impiety, in usurping the power of forgiving sins, and with spiritual tyranny, in imposing on the people the yoke of confession. The Catholic church cannot be charged with impiety, for exercising powers given by Christ to his apostles and to their lawful successors; nor with tyranny, in enforcing the observance of the precept of Christ.

Catholics believe that Christ granted to his

apostles, and to the priests of his church, power to forgive sins, by the administration of the sacraments of baptism, and penance, to those who are duly disposed to receive this grace. They believe that the sacrament of penance is an institution of Christ, no less than the sacrament of baptism. The belief of both rests on the same foundation. In both these sacraments, sin is forgiven by the ministry of man. Be baptised every one of you, for the remission of sins, Acts. ii. 38; whose sins you shall forgive, they are forgiven, John xx. 23. But no actual sin can be forgiven at the mere will of any pope, or any priest, or any person whomsoever, without a sincere sorrow for having offended God, and a firm resolution to avoid future guilt, and to atone for past transgressions. Any person who receives absolution, without these necessary dispositions, far from obtaining the remission of his sins, incurs the additional guilt of hypocrisy and profanation.

The obligation of sacramental confession to a priest is not an imposition of the church, but a precept of Christ. Without the voluntary confession of the penitent, the power of forgiving or retaining sins could not be exercised, with discretion and judgment, by the minister of the sacrament of penance. The confession of sin could never have been introduced had it not been received from the beginning as a divine ordinance for the remission of sin. It has been practised from the earliest ages of Christianity. It is attended with the most salutary effects. Besides being a means of obtaining the remission of sin, it affords relief to the troubled conscience, and opportunities of reclaiming deluded sinners from mischievous projects, and of causing reparation to be made for injuries done to persons, property, or character. It may be ridiculed by such as blaspheme those things which they know not (2 Pet. ii. 12), but will be ever cherished as a merciful and salutary institution by those who are sincerely sorry for their sins, and earnestly sue for pardon.

VI. *On Indulgences.*—The Catholic church is charged with encouraging guilt, by giving leave to commit sin, and granting an anticipated pardon for sins to come by indulgences. The Catholic church rejects with abhorrence the imputation that, by granting an indulgence, she grants permission to commit sin, or a pardon for sins to come. An indulgence, in the sense of the Catholic church, is no pardon for sin at all; it is only a remission of the whole or of a part of the temporal punishment which the justice of God often reserves to be undergone by the sinner, after the guilt of the sin has been remitted. The power of granting the remission of this temporal punishment was given by Christ to St. Peter and his successors, and has been exercised from the earliest ages. An indulgence, so far from exempting sinners from works of penance and piety, is an encouragement to the performance of such works, since they are prescribed as conditions for gaining the benefit of an indulgence.

Surely, therefore, the doctrine of the Catholic church concerning the sacrament of penance, confession, and indulgences, does not tend to

relax Christian morality, nor to encourage guilt, nor facilitate the commission of crime, but rather to put an end to sin, and to promote the exercise of every Christian virtue amongst men.

VII. *On the obligation of an oath.*—Catholics are charged with holding that they are not bound by any oath, and that the pope can dispense them from all the oaths they may have taken. We cannot sufficiently express our astonishment at such a charge. We hold that the obligation of an oath is most sacred; for by an oath man calls the almighty Searcher of hearts to witness the sincerity of his conviction of the truth of what he asserts, and his fidelity in performing the engagement he makes. Hence, whosoever swears falsely, or violates the lawful engagement he has confirmed by an oath, not only offends against truth, or justice, but against religion. He is guilty of the enormous crime of perjury.

No power in any pope, or council, or in any individual or body of men, invested with authority in the Catholic church, can make it lawful for a Catholic to confirm any falsehood by an oath; or dispense with any oath by which a Catholic has confirmed his duty of allegiance to his sovereign, or any obligation of duty or justice to a third person. He who takes an oath is bound to observe it, in the obvious meaning of the words, or in the known meaning of the person to whom it is sworn.

VIII. *On allegiance to our sovereign, and obedience to the pope.*—Catholics are charged with dividing their allegiance between their temporal sovereign and the pope. Allegiance relates not to spiritual but to civil duties; to those temporal tributes and obligations which the subject owes to the person of his sovereign, and to the authority of the state. By the term spiritual, we here mean that which in its nature tends directly to a supernatural end, or is ordained to produce a supernatural effect. Thus the office of teaching the doctrines of faith, the administration of the sacraments, the conferring and exercising of jurisdiction purely ecclesiastical, are spiritual matters. By the term temporal we mean that which in its nature tends directly to the end of civil society. Thus the right of making laws for the civil government of the state, the administration of civil justice, the appointment of civil magistrates and military officers, are temporal matters.

The allegiance which Catholics hold to be due and are bound to pay to their sovereign, and to the civil authority of the state, is perfect and undivided. They do not divide their allegiance between their sovereign and any other power on earth, whether temporal or ecclesiastical. They acknowledge in the sovereign, and in the constituted government of these realms, a supreme, civil, and temporal authority, which is entirely distinct from, and totally independent of, the spiritual and ecclesiastical authority of the pope and of the Catholic church. They declare that neither the pope, nor any other prelate or ecclesiastical person of the Roman Catholic church, has in virtue of his spiritual or ecclesiastical character any right, directly or indirectly, to any civil or temporal jurisdiction, power, superiority, pre-eminence, or authority, within this

realm; nor has any right to interfere, directly or indirectly, in the civil government of the United Kingdom, or any part thereof; nor to oppose, in any manner, the performance of the civil duties which are due to his majesty, his heirs, and successors, from all or any of his majesty's subjects; nor to enforce the performance of any spiritual or ecclesiastical duty, by any civil or temporal means. They hold themselves bound in conscience to obey the civil government of this realm, in all things of a temporal and civil nature, notwithstanding any dispensation or order to the contrary had, or to be had, from the pope or any authority of the church of Rome. Hence we declare that, by rendering obedience in spiritual matters to the pope, Catholics do not withhold any portion of their allegiance to their king, and that their allegiance is entire and undivided; the civil power of the state, and the spiritual authority of the Catholic church, being absolutely distinct, and being never intended by their divine author to interfere or clash with each other. 'Render unto Cæsar the things that are Cæsar's, and to God the things that are God's.'

IX. *On the claim of British Catholics to the property of the church establishment in England.*—British Catholics are charged with entertaining a pretended right to the property of the established church in England. We consider such a charge to be totally without foundation. We declare that we entertain no pretension to such a claim. We regard all the revenues and temporalities of the church establishment as the property of those on whom they are settled by the laws of the land. We disclaim any right, title, or pretension, with regard to the same.

X. *On the doctrine of exclusive salvation.*—Catholics are charged with uncharitableness, in holding the doctrine of exclusive salvation. Catholics are taught by their church to love all men, without exception: to wish that all may be saved, and to pray that all may be saved and may come to the knowledge of the truth, by which they may be saved. If the Almighty himself has assigned certain conditions, without the observance of which man cannot be saved, it would seem to be an act of impiety to attempt to annul those divinely-established conditions: and an act of great uncharitableness towards a fellow-man, to tell him that he may be saved without complying with the conditions prescribed by the Almighty.

The doctrinal principle of exclusive salvation belongs to the law of Christ. Has not Christ, who commands the belief of his revealed doctrines, pronounced, that he that believeth not shall be condemned? Mark xvi. 16. Has not Christ, who instituted baptism for the remission of sins, declared that except a man be born again, of water and of the Holy Ghost, he cannot enter into the kingdom of God? John iii. 5. Has not St. Paul enumerated a list of crimes, such as adultery, idolatry, hatred, seditions, heresies, murders, drunkenness, &c., of which he declares that they who do such things shall not obtain the kingdom of God? Gal. v. 21. Are not these exclusive conditions?

Whoever professes the law of Christ must profess the principle and doctrine of exclusive salvation. It is not the Catholic, it is God him-

self who will exclude from Heaven those who are not duly qualified for it by faith and good works.

But the Catholic, whilst he is bound to admit, and with firm faith to believe, this doctrinal principle, is bound also by the divine commandment not to judge. He is not allowed therefore to pronounce sentence of condemnation on individuals, who may live and die out of the external communion of the Catholic church: nor to pronounce sentence of condemnation against those who may die in an apparent state of sin. All those he leaves to the righteous judgment of the great Searcher of hearts, who at the last day will render to every man according to his works. But surely charity, as well as truth, must forbid one Christian to deceive another in the matter of such infinite importance as the eternal salvation of his soul. He who should persuade his neighbour that no condition for salvation is required on the part of man would deceive him. He who admits that any one such condition is required by the Almighty, admits the principle of exclusive salvation.

XI. *On keeping faith with heretics.*—Catholics are charged with holding the principle that they are not bound to keep faith with heretics. As Catholics we hold, and we declare, that all Catholics are bound by the law of nature, and by the law of revealed religion, to observe the duties of fidelity and justice to all men, without any exception of persons, and without any distinction of nation or religion.

British Catholics have solemnly sworn that 'they reject and detest that unchristian and impious principle that faith is not to be kept with heretics or infidels.' After this, the imputation of their holding this principle cannot but be felt to be them as grievously injurious to their religious and moral character.

*Conclusion.*—Having, in the foregoing declaration, endeavoured to state, in the simplicity of truth, such doctrines of our church as are most frequently misrepresented or misunderstood in this country, and to explain the meaning in which Catholics understand the terms by which

these doctrines are expressed in the language of their church; we confidently trust that this declaration and explanation will be received by our fellow-subjects in a spirit of candour and charity; and that those who have been hitherto ignorant of, or but imperfectly acquainted with our doctrines of faith, will do us the justice to acknowledge that, as Catholics, we hold religious principles, and entertain no opinions differing from those principles, which are not perfectly consistent with our duties as Christians and British subjects.

This declaration we, the undersigned, agree to publish as an exposition of our principles and doctrines on the subjects to which it relates.

- + WILLIAM, *Bishop of Halia, Vic. Ap. in the London District.*
- + PETER BERNARDIN, *Bishop of Teano, Vic. Apost. in the Western District.*
- + THOMAS, *Bishop of Bolina, Vic. Ap. in the Northern District.*
- + THOMAS, *Bishop of Cambysopolis, Vic. Apost. in the Midland District.*
- + ALEXANDER, *Bishop of Marburg, Vic. Apost. in the Lowland District of Scotland.*
- + RANALD, *Bishop of Aeryndela, Vic. Apost. in the Highland District of Scotland.*
- + PETER AUGUSTINE, *Bishop of ... Coadjutor in the Western District.*
- + JAMES, *Bishop of Usula, Coadjutor in the London District.*
- + THOMAS, *Bishop of Europun, Coadjutor in the Northern District.*
- + ALEXANDER, *Bishop of Cytura, Coadjutor in the Lowland District of Scotland.*

May 1826.

The ceremonials of this church, differing as they do in different countries, will be best seen by consulting the breviary, which, as adapted to the customs and language of each, differs in many minor particulars. For the greater ceremonies see also our articles BAPTISM and MASS.

**ROMANCE**, *n. s.* Fr. *roman*; Ital. *romanza*; Span. *romance*. [From the Roman or Romanish dialect of the Troubadour.] A fable of the middle ages; a tale of wild adventures in war or love; a fiction: to romance is to tell a fiction or lie: the noun-substantive that follows corresponding.

What resounds

In fable or romance of Uther's son. *Milton.*

A brave romance who would exactly frame,

First brings his knight from some immortal dame. *Waller.*

Some romances entertain the genius, and strengthen it by the noble ideas which they give of things; but they corrupt the truth of history. *Dryden.*

The allusion of the daw extends to all impostors, vain pretenders, and romancers. *L'Estrange.*

Shall we, cries one, permit

This lewd romancer, and his bantering wit? *Tate.*

Philosophers have maintained opinions more absurd than any of the most fabulous poets or romantic writers. *Keil.*

Zeal for the good of one's country a party of us have represented as chimerical and romantic. *Keil.*

A staple of romance and lies,  
False tears and real perjuries,  
Where sighs and looks are bought and sold,  
And love is made but to be told. *Keil.*

This is strange romancing. *Keil.*

The dun umbrage, o'er the falling stream.

Romantick hangs. *Keil.*

**ROMANIA, RUMELIA, OR RUM-ILLI, SEE RUMELIA.**

**ROMANIZE**, *v. a.* From Fr. *romana* latinize; fill with modes of the Roman spirit. *Johnsonize.*

He did too much romanize our tongue, Latin words he translated almost as much Latin found them. *Keil.*

Bulls or letters of election only serve in the Roman countries. *Keil.*

**ROMANO** (Julius), a celebrated painter, disciple of Raphael, who left him one of his

**beirs.** He was superior to most painters in his knowledge of antiquity, and was well skilled in architecture. He embellished Mantua with many of his performances both in painting and architecture; and died in that city in 1545, aged fifty-four.

**ROMANO**, a town of Austrian Italy, near the Oglio. It is surrounded with a wall, and defended by a castle. Population 3200. Twenty-six miles east of Milan.

**ROMANO**, a town of Piedmont, five miles

south of Ivrea. Inhabitants 2000. It stands on an eminence near the Chiusella, over which is a bridge. This was considered so important a pass when the French crossed the Alps, in 1800, that a bloody conflict took place here between them and the Austrians.

**ROMANS**, a town of the department of the Drome, France, on the Isere, eleven miles north-east of Valois. It has manufactures of silk and woollen, tanneries, and presses for making olive-oil.

## R O M E.

**ROME**, a city of Italy, on the Tiber, holds perhaps the most important place in history of any of the capitals of the world, as having been formerly the metropolis of one of the largest empires, and subsequently the centre of the most extensive ecclesiastical jurisdiction to which the human race ever submitted. The history of ancient Rome will, of course, first claim our attention. That of modern or ecclesiastical Rome is chiefly embraced in the rise and progress of **ROMAN CATHOLICISM**, which see.

### PART I.

#### ANCIENT ROME, REGAL.

**HISTORY.**—The ancient Romans derived their origin from *Æneas*, the Trojan hero; and, though some historians pretend to treat his voyage into Italy as a fable, yet no sufficient reasons for rejecting this account have been offered, nor has any more probable history of the origin of the Roman name been given. When the Greeks, by treachery or other means, were become masters of Troy, *Æneas*, with the forces under his command, retired into the fortress of the city and defended it bravely for some time; but at length, as we are told, he conveyed away his gods, his father, wife, and children, with every thing valuable, and, followed by a crowd of Trojans, fled to Mount Ida. Hither all his countrymen, who were anxious to preserve their liberty, flocked to him. His army thus augmented, and advantageously posted, continued for some time waiting for the departure of the Greeks, who were expected to return home as soon as they had pillaged the country. But these, after they had enriched themselves with the spoils of Troy and the neighbouring towns, turned their arms against the fugitives on the mountain. *Æneas*, to avoid the hazard of being forced from his last refuge, had recourse to negotiation. Peace was granted, on condition that he with his followers should quit the Trojan territories; and the Greeks, on their part, promised not to molest him in his retreat. Upon this assurance, *Æneas* equipped a fleet, to seek a settlement in some foreign land. At his departure he left his eldest son *Ascanius* with the *Dasyrites*, a people of Bithynia, who desired to have him for their king. But the young prince did not remain long with them; for when *Scamandrius* (or *Astyanax*) with the rest of the sons of *Hector*, whom *Neopolemus* permitted to return home from Greece,

repaired to him, he put himself at their head, and led them back to their native country. Our hero, having crossed the Hellespont, now arrived in the peninsula of *Pallene*, where he built a city, called *Æneia*, and left in it a part of those who had followed him. Thence he sailed to *Delos*, and to *Cythera*, where he erected a temple to *Venus*. He built another to her in *Zacynthus*, in which island he likewise instituted games, called the races of *Æneas* and *Venus*: the statues of both, *Dionysius* says, were standing to his time. In *Leucas*, where the Trojans landed, was also to be seen in his time a temple erected to *Venus*, the mother of *Æneas*. Nor were *Actium* and *Ambracia* without similar monuments of his arrival. At *Dodona* were found brazen vases upon which the name of the Trojan hero, who had made an offering of them to *Jupiter*, was engraven in old characters. Near *Buthrotos*, in *Epirus*, a Trojan camp which had escaped the injuries of time retained the name of *Troja*. All these antiquities, still subsisting in the reign of *Augustus*, were then looked upon as proofs of *Æneas's* voyage to *Epirus*: 'and that he came into Italy,' adds *Dionysius*, 'we have the concurrent testimony of all the Romans.'

The first land of Italy which *Æneas* made, after crossing the Ionian Sea, was *Cape Minerva*, in *Iapygia*; and here he went on shore. Afterwards, coasting along the south-east of Italy and the east and south sides of *Sicily*, he arrived with his fleet at the port of *Drepanum* in that island. *Elymus* and *Ægestus*, who had escaped from *Troy* a little before him, had brought a Trojan colony to this place. *Æneas* augmented it by a number of his followers, whom, pleased to have found a safe resting place after many dangers and fatiguing voyages, he willingly left behind him. *Æneas* next steered his course for Italy across the *Tyrrhenian Sea*. To the cape where he first landed he gave the name *Palinurus*, from one of his pilots who fell overboard. The little island of *Leucasia*, whither he sailed next, got its name from a daughter of *Æneas's* sister, who died there. The port of *Misenum*, the island of *Prochyta*, and the promontory of *Cajeta*, where he successively arrived, were so called from being the burial places, the first of a noble Trojan his companion, the second of his kinswoman, and the third of his nurse. At length the Trojan prince and his chosen band finished their tedious and painful voyages, on the coast of the since

famous Latium. This was a small territory on the east side of the Tiber, containing a part of the present Campagna di Roma; Latinus was the king of it; his capital, Laurentum; his subjects, a people who, till his time called Aborigines, had from him taken the name of Latins. Here, far removed from their implacable enemies, the Greeks, Æneas and his followers undertook to raise a second Troy: they fortified a camp near the mouth of the Tiber, gave it the name of Troy, and flattered themselves with the hopes of a quiet settlement. When Æneas arrived in Italy Latinus was engaged in a war with the Rutuli, a neighbouring people, in which he was attended with but very indifferent success, when news was brought him that a foreign army had made a descent on his coasts, pillaged his dominions, and were fortifying themselves in a camp near the sea. Hereupon he marched against them with all his forces; but finding them, as he drew near, well armed, and regularly drawn up, he thought it advisable to forbear engaging troops that appeared so well disciplined, and to desire a parley. In this conference, Latinus understanding who they were, and being at the same time struck with terror, and touched with compassion for those brave but unfortunate men, entered into a treaty with them, and assigned them a tract of land for a settlement, on condition that they should employ their arms and exert their valor in defence of his dominions, and look upon the Rutuli as a common enemy. This condition Æneas readily accepted; and complied with his engagement so faithfully that Latinus came at length to repose an entire confidence in the Trojans; and, in proof of it, gave him Lavinia, his only child, in marriage, thus securing to him the succession to the throne.

Æneas, to testify his gratitude to Latinus and affection for Lavinia, gave her name to his camp, and called it Lavinium. The Trojans followed the example of their leader; and, by making alliances with Latin families, became, in a short time, one and the same people with the Latins. In the mean time Turnus, the queen's nephew, who had been brought up in the palace under the eye of Latinus, and entertained hopes of marrying Lavinia, and succeeding to the throne, seeing the princess bestowed on a stranger, and all his views defeated, went over to the Rutuli, and, by stirring them up, brought on a battle between them and the Latins, in which both he and Latinus were killed. Thus Æneas, by the death of his father-in-law, and by that of a troublesome rival, came into the quiet possession of the kingdom of Latium, which he governed with great wisdom, and transmitted to his posterity. Æneas reigned three years, during which he established the worship of the gods, and to the religion of the Latins added that of Troy. The two Palladiums, which had been the protectors of that city, became the tutelary deities of Lavinium, and in after ages of the whole Roman empire. The worship of Vesta was likewise introduced by Æneas; and virgins, from her called Vestals, were appointed to keep a fire continually burning in honour of that goddess. Jupiter, Venus,

and many other deities who had been revered in Troy, became known to the Latins by Æneas. Meantime the Rutuli, ancient enemies of the Latin name, entering into an alliance with Mezentius, king of the Tyrrhenians, took the field to drive out those new comers. Æneas marched out against them at the head of his Trojans and Latins. Hereupon a battle ensued, which lasted till night; when Æneas being pushed to the banks of the Numicus, which ran close by Lavinium, and forced into that river, was there drowned. The Trojans concealed his body; and, pretending that he had vanished on a sudden, made him pass for a deity among his credulous subjects, who erected a temple to him under the title of Jupiter Indiges.

Upon the death of Æneas, his son Euryleon, called also Ascanius and Iulus, succeeded; but as he did not think it advisable to venture a battle in the beginning of his reign, with a formidable enemy, who promised himself great success from the death of Æneas, he tried whether he could, by treaty, put an end to so dangerous a war. But the haughty Mezentius demanded of the Latins, as one of the conditions of a peace, that they should pay him yearly, by way of tribute, all the wine produced in the territory of Latium. Ascanius rejected the proposal with indignation; and having caused all the vines throughout his dominions to be consecrated to Jupiter, and thus put it out of his power to comply with the enemy's request, he resolved to make a vigorous sally, and try whether he could, by force of arms, bring the insulting Tyrrhenian to more reasonable terms. The main body of the enemy's army was encamped at some distance from Lavinium; but Lausus, the son of Mezentius, with the flower of their youth under his command, lay entrenched at the gates of the city. The Trojans, marching out in the night, attacked the post where Lausus commanded, forced his entrenchments, and obliged his troops to save themselves by flying to the main body of the army encamped on the plain; but the unexpected arrival and overthrow of their advanced guard struck them with such terror, that instead of stopping the flight of their companions, they fled with them, in great disorder, to the neighbouring mountains. The Latins pursued them, and in the pursuit Lausus was killed; whose death so discouraged Mezentius that he immediately sued for peace; which was granted him, upon condition that for the future the Tiber should be the boundary between the Latin and Etrurian territories. In the mean time Lavinia, who had been left with child by Æneas, entertaining a strong jealousy of the ambition of her son-in-law, retired to the woods, and was there delivered of a son, who, from his father, and the place of his birth, had the name of Æneas Sylvius; but as the queen's flight, who had disappeared on a sudden, raised suspicions at Lavinium prejudicial to the reputation of Ascanius, he caused search to be made after Lavinia, calmed her fears and prevailed upon her to return to the town with her son, whom he ever after treated as a brother. Lavinium grew every day more populous; and as it was in reality the patrimony of Lavinia, and the

inheritance of her son Sylvius, Ascanius resolved to resign it to them, and build elsewhere another city for himself. This he made the place of his residence, and the capital of his new kingdom, calling it Alba Longa; Alba, from a white sow, which we are told Æneas had found in the place where it was built; and Longa, to distinguish it from another town of the same name in the country of the Marsi; or rather because it extended, without having much breadth, the whole length of a lake near which it was built. It was thirty years after the building of Lavinium that Ascanius fixed his abode at Alba; and there he died, after a reign of about thirty-eight years, twelve of which he had resided at his new settlement. He left a son called Iulus; so that between him and Sylvius lay the right of succession to the Latin throne; the latter being the son, and the former the grandson, of Æneas. The Latins not thinking it their interest to continue divided, as it were, into two states, resolved to unite Alba and Lavinium into one sovereignty; and as Sylvius was born of Lavinia the daughter of Latinus, and had thereby an undoubted title to the kingdom of his grandfather, whereas the other was but the son of a stranger, the Latins bestowed the crown on Sylvius; and, to make Iulus some amends, decreed to him the sovereign power in affairs of religion; a power which thenceforth continued in his family. Sylvius was succeeded by thirteen kings of the same race, who for nearly 400 years reigned at Alba; but we scarcely know any thing of them besides their names, and the years of their respective reigns. Æneas Sylvius died, after a reign of twenty-nine years. His son Æneas Sylvius II. governed Latinus thirty-one years.

Latinus Sylvius, who succeeded him, swayed the sceptre fifty-one years—Alba reigned thirty-nine; Capetus, by Livy named Atys, twenty-six; Capys twenty-eight; and Capetus II. thirteen. Tiberinus, who succeeded him, engaged him in a war that proved fatal to him; for in a battle, which was fought on the banks of the Albula, he was forced into that river and drowned. From him the river took the name of Tiber, which it has borne ever since. Agrippa succeeded Tiberinus after a reign of eight years; and left the throne, which he had held forty-one years, to Alladius, who reigned nineteen, and was succeeded by Aventinus, who left his name to the hill Aventinus, where he was interred. Procas, who succeeded him, and reigned twenty-three years, was the father of Numitor and Amulius; and at his death bequeathed the throne to his eldest son Numitor. But Amulius, who surpassed his brother in courage, drove him from the throne; and, to secure it to himself, murdered Ægestus, Numitor's only son, and consecrated his daughter Rhea Sylvia to the worship of Vesta, by which she was obliged to perpetual virginity. But this precaution proved ineffectual; for, as the vestal was going to a neighbouring spring to fetch water for the performance of a sacrifice to Mars, she was met and violated by a man in a military habit, like that in which the god Mars is represented. Some authors think that this counterfeit Mars was a lover come thither by her appointment; others charge Amu-

lius himself with using this violence to his niece, not so much to gratify his desires as to have a pretence to destroy her. For ever after he caused her to be carefully watched, till she was delivered of two sons; and then, exaggerating her crime in an assembly of the people, he prevailed upon them to sentence her to death, and to condemn the fruit of her amour to be thrown into the Tiber. The sentence against Rhea was, according to some authors, changed by Amulius, at the request of his daughter Antho, into perpetual confinement, but executed against the twins; who being laid in a wooden trough, and carried to the foot of Mount Palatine, were there turned adrift on the Tiber, which at that time overflowed its banks. But the wind and stream proved both so favorable that at the fall of the water the two infants were left safe on the strand, and were there found by Faustulus, the chief of the king's shepherds, and suckled by his wife Acca Laurentia, who for her disorderly life was called Lupa; and this gave rise to the fabulous miracle of their being nursed by a she wolf.

As Faustulus was probably well acquainted with the birth of the twins, he took more than ordinary care of their education, and sent them to Gabii to be instructed in Greek literature. As they grew up there appeared something in their mien and air which commanded respect; and the ascendant which they assumed over the other shepherds made them dreaded, we are told, in the forests. A quarrel happening between the herdsman of Amulius and those of Numitor, the two brothers took the part of the former against the latter; and, blood being shed in the fray, the adverse party, to be revenged on the twins Romulus and Remus, on the festival of Lupercalia, surprised Remus, and carried him before Numitor, to be punished according to his deserts. But Numitor, feeling himself touched in the prisoner's favor, asked him where he was born, and who were his parents. His answer immediately struck Numitor with a lively remembrance of his two grandsons; their age, which was about eighteen years, agreed with the time when the two infants were exposed upon the Tiber; and there needed no more to change his anger into tenderness. In the mean time Romulus, eager to rescue his brother, and pursue those that carried him off, was preparing to be revenged on them; but Faustulus dissuaded him from it; and, on that occasion, disclosing to him his birth, awakened in his breast sentiments worthy of his extraction. He resolved to attempt the deliverance of his mother and grandfather from oppression. With this view he assembled the country people, and engaged them to come to the city on an appointed day, and enter it at different gates, provided with arms which they were to conceal. Meantime Numitor made the same discovery to Remus concerning his parents, and the oppressions they groaned under; which so fired him that he was ready to embark in any enterprise. But Numitor only desired him to acquaint his brother with what he had heard, and to send him to his house. Romulus came; and was followed by Faustulus, who took with him the trough or skiff in which the twins had been exposed, to show it to Numitor; but, as

the shepherd betrayed an air of concern and earnestness in his looks, he was stopped at the gates of the city, led before Amulius, and examined concerning his burden. It was easily known by its make and an inscription, which was still legible; and therefore Faustulus owned what it was, and confessed that the twins were living; but, to gain time, pretended that they were feeding flocks in a remote desert. In the mean time, the usurper's death being resolved on, Remus undertook to raise the city, and Romulus to invest the king's palace. The country people came at the time appointed, and formed themselves into companies, each consisting of 100 men. They had no other ensigns but bundles of hay hanging upon long poles, which the Latins at that time called *manipuli*; and hence came the name of *manipulares*, originally given to troops raised in the country. With this tumultuous army Romulus beset the avenues of the palace, forced the guard, and having killed the tyrant, after he had reigned forty-two years, restored his grandfather Numitor to the throne. Affairs being thus settled at Alba, the two brothers, by the advice of Numitor, undertook the founding of a new colony. The king bestowed on them those lands near the Tiber where they had been brought up, supplied them with all manner of instruments for breaking up ground, with slaves, and beasts of burden, and granted full liberty to his subjects to join them. Hereupon most of the Trojans, of whom there still remained fifty families in Augustus's time, chose to follow the fortune of Romulus and Remus, as did also the inhabitants of Pallantium and Saturnia, two small towns. For the more speedy carrying on of the work, it was thought proper to divide those who were to be employed in the building of the city into two companies, one under the command of Romulus, the other of Remus; but this division, which was designed purely with a view to the public welfare, and that the two parties might work by way of emulation, gave birth to two factions, and produced a jealousy between the two brothers, which broke out when they came to choose a place for the building of their new city; for Remus was for the Aventine, and Romulus for the Palatine mount. Upon which, the matter being referred to their grandfather, he advised the contending parties to have recourse to the gods, and to put an end to the dispute by augury, to which he was himself greatly addicted. The day appointed for the ceremony being come, the brothers posted themselves each upon his hill; and it was agreed that whoever should see the first light, or the greatest number of vultures, should gain his cause. After the two rivals had waited some time for the appearance of a favorable omen, Romulus affirmed that he had seen twelve; but Remus, having actually seen six, suspected deceit; and, being told that Romulus had not seen the twelve vultures till after he had seen six, he insisted on the time of his seeing them, and the other on the number of birds he had seen. This widened the breach, and, their parties being divided, while each man espoused the cause of his leader, the dispute grew so warm that, from words, they came at length to blows. The shepherd Faustulus, who was equally fond of both

the brothers, endeavouring to part the combatants, was killed. Some writers tell us that Remus likewise lost his life in the fray; but the greater number place his death later, and say that he was killed by one Fabius, for having, in derision, leaped over the walls of the new city: but the more common report, according to Livy, was, that Remus fell by the hand of his brother.

Romulus, being now head of the colony, by having subdued his brother's party, applied his thoughts wholly to the building of the city. He chose Mount Palatine for its situation, and performed all those ceremonies which the superstition of the Etrurians had introduced. He first offered sacrifices to the gods; ordered all the people to do the same; and decreed that eagles should be the auspices of his new colony. After this, great fires were kindled before their tents, and all the people leaped through the flames to purify themselves. They next dug a trench round the spot where the assemblies of the people were afterwards held, and threw into it the first fruits of whatever they were allowed to make use of for food; every man of the colony was ordered to cast into the same trench a handful of earth, brought either from his own or some neighbouring country. The trench they called *Mundus*, that is, the world, and made it the centre round which the city was to be built. The Romulus, yoking a bull and a cow to a plough, the coulter whereof was brass, marked out, by a deep furrow, the whole compass of the city. These two animals, the symbols of marriage, by which cities are peopled, were afterwards slain upon the altar. All the people followed the plough, throwing inwards the clods of earth which the plough-share sometimes turned outwards. Wherever a gate was to be made, the plough was lifted up, and carried; and hence came the Latin word *porta*, a gate, derived from the verb *portare*, to carry. As Mount Palatine stood by itself, the whole was enclosed within the line made by the plough, which formed almost the figure of a square; whence, by Dionysius Halicarnassensis, it is called *Roma Quadrata*. As to the exact year of the foundation of Rome, Fabius Pictor, the most ancient of all the Roman writers, places it in the end of the seventh Olympiad; that is, according to Usher, in the year of the world 3256, of the flood 1600, and 748 before the Christian era. The Romans began to build, as Plutarch and others say, on the 21st of April; which day was consecrated to Pales, goddess of the shepherds; whence the festival of Pales, and that of the foundation of the city, were afterwards jointly celebrated at Rome.

Rome, as left by its rude founder, consisted of about 1000 houses, or huts; and was properly speaking a mere village, whereof the principal inhabitants followed the plough; being obliged to cultivate with their own hands the ungrateful soil of a barren country. Even the walls of Romulus's palace were made of rushes, and covered with thatch. As every one had chosen his ground to build upon, without any regard to the regularity and beauty of the whole, the streets were both crooked and narrow. In short, till it was rebuilt after the burning of it by the Gauls,

Rome was rather a disorderly heap of huts than a city. Romulus next assembled the people, and desired them to choose what kind of government they would obey. Monarchy was the unanimous voice of the Romans, and Romulus was elected king. After this he applied himself to the establishment of good order and subordination among his subjects. He put on a habit of distinction for himself, appointed twelve lictors to attend him as guards, divided his subjects, who at this time consisted only of 33,000 men, into curiæ, decuriæ, patricians, plebeians, patrons, clients, &c. After this he formed a senate, consisting of 100 persons, chosen from among the patricians; and a guard of 300 young men called celereæ, who attended the king, and fought either on foot or on horseback, as occasion required. The king's office at home was to take care of religious affairs; to be the guardian of laws and customs; to decide the weightier causes between man and man, referring those of smaller moment to the senate; to call together the senators and assemble the people; first delivering his own opinion concerning the affair he proposed, and then ratifying by his consent what was agreed on by the majority. Abroad, and in the time of war, he was to command the army with absolute authority, and to take care of the public money. The senate were to be judges in matters of small importance, and to debate and resolve upon such public affairs as the king proposed by a plurality of voices. The people were allowed to create magistrates, enact laws, and resolve upon any war which the king proposed; but in all these things the consent of the senate was necessary. Romulus next proceeded to settle the religious affairs of his people. Many of the Trojan and Phrygian deities were added to those whom the aborigines already worshipped. He chose priests, instituted festivals, and laid the foundation of a regular system of religion; after which, as his colony was still thinly peopled, he opened an asylum for fugitive slaves, homicides, outlaws, and debtors. These, however, he did not at first receive within the walls, but appointed for their habitation the hill Saturnius, called afterwards Capitolinus, on which he erected a temple to a divinity of his own invention, whom he named the Asylean god, under whose protection all criminals were to live securely. But afterwards, when the city was enlarged, the asylum was enclosed within the walls, and those who dwelt in it were included among the citizens of Rome. When Romulus had thus settled every thing, a supply of women was still wanting to perpetuate its population. The neighbouring nations refused to give their daughters in marriage to such a crew of vagabonds as had settled in Rome; wherefore Romulus, by the advice of his grandfather Numitor, and with the consent of the senate, proclaimed a solemn feast and public games in honor of the Equestrian Neptune, called Consus. This occasioned a great concourse of people, who flocked from the adjacent parts to behold those pompous shows, together with the new city. But, in the midst of the solemnity, the Romans, rushing in with their swords drawn, seized all the young women, to the number of 683, for whom Romulus chose husbands. Among all those who

were thus seized, only one married woman, named Hersilia, was found; and Romulus kept her for himself.

This violence soon brought on a war with the neighbouring nations. Acron, king of Cænina, a city near Latium, having entered into a league with the inhabitants of Crustumini and Antemnæ, invaded the Roman territories. Romulus marched against them without delay, defeated the confederate army, killed their king in single combat, decreed himself a triumph, and consecrated the spoils of Acron to Jupiter Feretrius, under the name of Opima Spolia. The city of Cænina was razed to the ground, and the inhabitants transplanted to Rome, where they were admitted to the privilege of citizens. The king then marched with one legion (consisting at this time of 3000 foot and 300 horse) against the Crustumini and Antemnates, both of whom he defeated in battle, and transplanted the inhabitants to Rome; which being incapable of holding such a number, Romulus took in the hill Saturnius, on the top of which he built a citadel, committing the care of it to a noble Roman named Tarpeius. The citadel was surrounded on all sides with ramparts and towers, which equally commanded the city and country. From the foot of the hill Saturnius a wall was carried on quite to the Tiber, and a gate opened in it named Carmentalis, from Carmenta the mother of Evander, who either lived there, or had some chapel or altar erected to her. Romulus had now become so formidable to his neighbours, and had so well established his reputation for clemency, that several cities of Etruria voluntarily submitted to him. Cælius, an Etrurian general, led his troops to Rome, and settled on a hill near the city, from him named Mount Cælius. The Sabines, however, not dismayed at this increase of the Roman forces, sent a deputation to Romulus, demanding a restitution of the young women who had been carried off; and upon his refusal marched to Rome with an army of 25,000 foot and 1000 horse, under their king Titus Tatius. Romulus, having received supplies from Numitor and from Etruria, likewise took the field, with 20,000 foot and 800 horse, with whom he seized an advantageous post, and fortified himself so strongly that he could not be attacked. The Sabine monarch then began to be apprehensive of the event; but was extricated out of his difficulties by the treachery of Tarpeia, daughter to the governor of the citadel, who agreed to betray that fortress to him on condition of being rewarded with what the Sabines wore on their left arms, meaning their bracelets. But when they became masters of this important place they crushed Tarpeia under their bucklers, pretending that thus they discharged their promises, as they wore their bucklers also on their left arms. The possession of the citadel enabled the Sabines to carry on the war with more success; but at last, in a general engagement, they were driven back into the citadel, whither they were pursued by the Romans; but the enemy, rolling down great stones from the top of the hill, wounded Romulus on the head, so that he was carried insensible out of the field of battle, while, in the mean time, his troops were repulsed, and pursued to the very gates of Rome. However the king, soon



recovering, encouraged his routed troops, and drove the enemy back into the citadel. But, while the two nations were thus fiercely contending, the women, for whose cause the war had been commenced, undertook the office of mediators; and, having obtained leave from the senate, marched in a body to the camp of the Sabines, where they pleaded the cause of their husbands so effectually that a treaty of union between the two nations was set on foot, and a peace was at last concluded, on the following terms:—1. That the two kings should reside and reign jointly at Rome. 2. That the city should still, from Romulus, be called Rome, but the inhabitants Quirites, a name till then peculiar to the Sabines. 3. That the two nations should become one; and that the Sabines should be made free in Rome, and enjoy all the privileges of Roman citizens. As Rome was chiefly indebted for this increase of her power and splendor to the Sabine women, honorable privileges and marks of distinction were allowed them. Every one was commanded to give way to them; in capital causes they were exempted from the jurisdiction of the ordinary judges; and their children were allowed to wear a golden ball hanging from their necks, and a particular kind of robe called prætexta, to distinguish them. The two kings reigned with great harmony for five years; during which time the only military exploit they accomplished was the reduction of the city of Cameria, at a small distance from Rome. 4000 of the Camerini were transplanted to Rome, and a Roman colony sent to repeople Cameria; soon after which the Sabine king was murdered by the Lavinians on account of his granting protection to some of his friends, who had ravaged their territories. The Lavinians, fearing the resentment of Romulus, delivered up the assassins into his hand; but he sent them back unpunished: which gave occasion to suspect that he was not displeased with the death of his colleague. Soon after the death of Tattius Rome was afflicted with famine and pestilence, which encouraged the Camerini to revolt; but Romulus, marching against them suddenly, defeated them with the loss of 6000 men. After which he attacked the Fidenates, whose city stood about five miles from Rome, took their capital, and made it a Roman province. This drew upon him the resentment of the Veientes, a powerful nation in the neighbourhood, who claimed Fidenæ as within their jurisdiction; but their forces being defeated in two engagements, and a great number of them taken prisoners, they were obliged to sue for peace. Romulus granted them a truce for 100 years, on condition that they delivered to him seven small towns on the Tiber, together with some salt pits near the mouth of that river, and sent fifty of their chief citizens as hostages to Rome. The prisoners taken in this war were all sold for slaves. The remaining part of the reign of Romulus was spent in making laws for the good of his people; but towards the end of his reign he began to behave in an arbitrary manner. He paid no longer any regard to the senate, but assembled them only for form's sake to ratify his commands. The senate therefore conspired to destroy him, and accomplished their purpose

while he was reviewing his troops. A violent storm of hail and thunder dispersed the army; and the senators taking this opportunity, when they were left alone with the king, killed him, and conveyed his body out of sight. Some say that, to conceal the murder, they cut his body in pieces, each of them carrying away a part under his robe; after which they told the people that their king was on a sudden surrounded by flame, and snatched up into heaven. This did not satisfy the soldiery, and violent disturbances were about to ensue, when Julius Proculus, a senator of distinction, having assembled the curiæ, told them, with an oath, that Romulus had appeared to him, and enjoined him to acquaint the people that their king was returned to the gods from whom he originally came, but that he would continue to be propitious to them under the name of Quirinus.

Romulus reigned, according to the common computation, thirty-seven years; but some historians make his reign only about seventeen; and it seems unaccountable that nothing important should have been recorded of him during a period of twenty years. The death of Romulus was certainly followed by an interregnum, during which the senators, to prevent anarchy, seem to have taken the government into their own hands; and a portion of this may have been confounded with the reign of Romulus. Tattius had added another 100 to that body, and these 200 senators divided themselves into decuries or tens. These drew lots which should govern first; and the decury to whose lot it fell enjoyed the supreme authority for five days: yet in such a manner that one person only of the governing decury had the ensigns of sovereignty at a time. To these another decury succeeded, each of them sitting on the throne in his turn, &c. But the people, soon growing weary of such frequent changes of masters, obliged the senate to resolve on the election of a king. Some difficulties, however, occurred; the Romans did not choose to be subject to a Sabine; and the Sabines, as they had been subject to Romulus after the death of Tattius, insisted that the king should be chosen out of their nation. At last it was agreed that the king should be a Sabine, but that the Romans should make the choice. In consequence of this determination, the Romans elected Numa Pompilius, who had married Tatia, the daughter of Tattius. Numa, devoted entirely to philosophy and superstition, and wandering from solitude to solitude, had impressed the people with a great opinion of his sanctity: he at first rejected the offer of the kingdom; but, being at last prevailed upon, he set out for Rome, where he was received with loud acclamations, and had his election unanimously confirmed by the senate. His reign is not memorable for battles or conquests. He was averse to war; and made it his study to soften the manners of the Romans, rather than to exalt them to superiority over their neighbours. He dismissed the celeres, encouraged agriculture, and divided the citizens into distinct bodies of tradesmen, so as to abolish the distinction between Romans and Sabines. In this division the musicians held the first rank, be-

cause they were employed in the office of religion. The goldsmiths, carpenters, curriers, dyers, taylors, &c., formed also distinct communities, and were allowed to make bye-laws among themselves, to have their own festivals, particular sacrifices, &c.—Numa is said to have had pretty just notions of the Supreme Being; he nevertheless added innumerable superstitions to those he found in Rome. He divided the ministers of religion into eight classes, appointing to each their office with the greatest precision; erected a temple to Janus, the symbol of prudence, which was to remain open in time of war, and to be shut in time of peace. Another temple was erected to Bona Fides; and he invented a new kind of deities called Dii Termini, or boundaries, which he caused to be placed on the borders of the Roman state, and of each man's particular lands.—The last reformation which Numa undertook was that of the calendar. These are the most remarkable transactions of his reign, which is said to have continued forty-three years: though some think that its duration could not be above fifteen or sixteen.

Numa's death was followed by a short interregnum; after which Tullus Hostilius, the son or grandson of the famous Hersilia, was unanimously chosen king. Being of a bold and fiery temper, he did not long continue to imitate his peaceful predecessor. The Albans, indeed, soon gave him an opportunity of exercising his martial disposition. Cælius, or Cluilius, who was at the head of the Alban republic, jealous of the growing greatness of Rome, privately commissioned some of the most indigent of his subjects to waste the Roman territory; in consequence of which a Roman army entered the territories of Alba, engaged the robbers, killed many, and took a great number prisoners. A war soon commenced, in consequence of this, between the two nations; but, when the armies came in sight of each other, their ardor cooled, neither of them seeming inclined to come to an engagement. This inaction raised a great discontent in the Alban army against Cluilius; insomuch that he came to a resolution of giving battle to the Romans next morning, or of storming their trenches if they should decline it. Next morning, however, he was found dead in his bed; after which the Albans chose in his stead Metius Fuffetius, a man remarkable for his hatred to the Roman name, as Cluilius had been before him. Fuffetius, however, continued in the same state of inactivity as his predecessor, until he received certain intelligence that the Veientes and Fidenates had resolved to destroy both Romans and Albans when they should be weakened by a battle. Fuffetius then resolved to come to an accommodation with the Romans; and, having obtained a conference with Tullus, both seemed equally desirous of avoiding the calamities of war. But, to establish the peace on the best foundation, Tullus proposed that the chief families in Alba should remove to Rome, or, if they were unwilling to leave Alba, that one common council should be established to govern both cities, under the direction of one of the two sovereigns. Fuffetius took aside those who attended him, to consult with them about the pro-

VOL. XVIII.

posal; but they, though willing to come to an accommodation with Rome, absolutely refused to leave Alba. The only difficulty remaining, then, was to settle which city should have the superiority; and, as this could not be determined by argument, Tullus proposed to determine it by single combat betwixt himself and Fuffetius. This proposal, however, the Alban general declined; and it was at last agreed that three champions should be chosen out of each camp to decide the difference. This produced the famous combat between the Horatii and Curiatii, by which the sovereignty was decided in favor of Rome. See HORATIUS. Tullus now resolved to call the Fidenates to an account for their treacherous behaviour during the war with Alba, and therefore cited them to appear before the senate; but they refused to appear, and took up arms in conjunction with the Veientes. Fuffetius, in obedience to the orders of Tullus, joined him with the Alban troops; but the day before the battle he acquainted the principal officers with his design, which was to stand neuter till fortune had declared for one side, and then to join with the conqueror. This design being approved, Fuffetius, during the engagement, retired with his forces to a neighbouring eminence. Tullus perceived his treachery; but, dissembling his uneasiness, told his men that Fuffetius had possessed himself of that hill by his order, and that he was thence to rush down upon the enemy. The Veientes, in the mean time, were dismayed, and the Romans obtained the victory. After the battle, Tullus returned privately to Rome in the night; and, having consulted with the senate about the treachery of Fuffetius, returned to the camp by break of day. He then detached Horatius, who had conquered the three Curiatii, with a chosen body of horse and foot, to demolish Alba, as had been concerted at Rome. In the mean time, he commanded both the Roman and Alban troops to attend him unarmed, but gave private orders to the Romans to bring their swords concealed under their garments. When they were assembled, he laid open the treachery of Fuffetius, and ordered him to be torn in pieces by horses. His accomplices were all put to the sword; and the inhabitants of Alba carried to Rome, where they were admitted to the privileges of citizens, and some of them even admitted into the senate. Tullus now turned his arms against Fidenæ, which he again reduced under the Roman yoke; and took Medulia, a strong city of the Latins; after which he waged a successful war with the Sabines, whose union with the Romans seems to have ceased with the time of Numa. This was the last of his martial exploits; after which we hear no more of him, but that he became extremely superstitious in his advanced years, giving ear to many foolish stories, and for which he appointed nine days expiatory sacrifices. As to the manner of his death authors are not agreed. Some tell us that he was killed by lightning, together with his wife, children, and his whole family; while others say that he was murdered with his wife and children by Ancus Martius. He died after a reign of thirty-three years, leaving the city greatly increased, but the dominions much the

2 Y

same as they had been in the time of Romulus.

After a short interregnum, Ancus Martius, the grandson of Numa by his daughter Pompilia, and Numa Martius, his relation, was unanimously chosen by the people and senate. Though naturally inclined to war, he began his reign with attempting to restore the ceremonies of Numa, which had been neglected under Tullus Hostilius. He endeavoured also to draw the attention of his people to husbandry and the peaceful arts; advising them to lay aside all sorts of violence, and to return to their former employments. This gained him the affection of his subjects, but brought upon him the contempt of the neighbouring nations. The Latins, pretending that their treaty with Rome was expired, made inroads into the Roman territories. Ancus, after using the ceremonies directed by Numa, took the field with an army consisting entirely of new levied troops, and reduced the cities of Politorium, Tillena, and Ficana, transplanting the inhabitants to Rome. A new colony of Latins re-peopled Politorium; but Ancus retook the place next year, and entirely demolished it. He then laid siege to Medulia; which, though it had been ruined by Tullus Hostilius, was now stronger than ever. It submitted after a siege of four years, when Ancus found himself obliged to undertake a second expedition against Ficana, which he had before reduced; and it was not without the utmost difficulty that he reduced it a second time. After this he defeated the Latins in a pitched battle; vanquished the Fidenates, Veientes, and Sabines; and having taken in the hill Janiculum to be included within the walls, and built the port of Ostia, he died in the twenty-fourth year of his reign.

Ancus Martius left two sons, one an infant, and the other about fifteen years of age. Both of these he put under the tuition of Tarquin, the son of Lucumo, a merchant in Corinth, who fled from that city to secure his wealth from Cypselus, a tyrant of the place. He settled in Tarquinii, one of the principal cities in Etruria; but finding that he could not there attain to any of the principal posts in the city, on account of his foreign extraction, he removed to Rome, where he had been gradually raised to the rank of patrician and senator. The death of Ancus Martius gave him an opportunity of assuming the regal dignity and setting aside his pupils; and in the beginning of his reign he took care to strengthen his party in the senate by adding 100 more to that body. These were called senators *minorum gentium*, because they were chosen out of the plebeians; however, they had the same authority in the senate as the others, and their children were called patricians. Tarquin was not inferior to any of his predecessors, either in his inclination or abilities to carry on a war. He recommenced hostilities with the Latins; from whom he took the cities of Apiolæ, Crustumium, Nomentum, and Collatia. The inhabitants of Apiolæ were sold for slaves; but those of Crustumium and Nomentum, who had submitted after their revolt, were treated with great clemency. The inhabitants of Collatia were disarmed, and obliged to pay a large sum of money; the sovereignty of it being given

to Egerius, the son of Arunx, Tarquin's brother; whence he took the name of Collatinus, which he transmitted to his posterity. Corniculum, another city of Latium, was taken by storm, and reduced to ashes. This progress having greatly alarmed the Latins, several of them joined their forces to oppose such a formidable enemy; but, being defeated in a bloody battle near Fidene, they were obliged to enter into an alliance with Rome: upon which the Latins, having held a national conference, entered into a league with the Etrurians, and again took the field with a very numerous army. But Tarquin, having defeated the confederate armies in two very bloody battles, obliged the Latin cities to submit to dependence on Rome; and, having entered the city in triumph, built the circus with the spoils taken from the enemy. The war with the Latins was scarcely ended when another commenced with Etruria. This was accounted the most powerful nation in Italy, and was then divided into twelve tribes or lucumonies. These appointed a national assembly, in which it was decreed that the whole force of Etruria should be employed against Tarquin; and, if any city presumed only to stand neuter, it should be forever cut off from the national alliance. Thus a great army was raised, with which they ravaged the Roman territory, and took Fidene by the treachery of some of its inhabitants. Tarquin, not being in a condition to oppose them at first, was obliged to submit to their ravages for a whole year; after which he took the field with all the forces he could raise. The Roman army was divided into two bodies, one under the king, the other under his nephew Collatinus. The latter, having divided his forces to plunder the enemy, was defeated; but Tarquin, in two engagements, vanquished the army which opposed him. He then marched against Fidene, where he gained a third battle; after which he took the city. The citizens suspected of betraying it to the enemy were whipped to death; the rest were banished, and their lands divided by lot among the Roman soldiers. Tarquin now hastened to oppose the new army of the Etrurians, before their forces could be properly collected; and having come up with them at Eretum, about ten miles from Rome, defeated them with greater slaughter, for which victory he was decreed a triumph by the senate: while the enemy were glad to sue for peace; which Tarquin granted, upon the sole condition of their owning his superiority. Accordingly, the Etrurians sent him all the ensigns of royalty which were in use among them, viz. a crown of gold, a throne of ivory, a sceptre with an eagle on the top of it, a tunic embroidered with gold and adorned with figures of palm branches, together with a purple robe enriched with flowers of several colors. Tarquin, however, would not wear these magnificent ornaments till the senate and people had consented to it by an express law. He then applied the regalia to the decoration of his triumph and never afterwards laid them aside. In this triumph he appeared in a gilt chariot, drawn by four horses, clothed in a purple robe, and a tunic embroidered with gold, a crown on his head, and a sceptre in his hand, attended by twelve lictors

with their axes and fasces. Tarquin, having now obtained some respite from war, began to ornament the city. He built the walls with hewn stone, and erected those famous common sewers which have deservedly been ranked among the wonders of the world. Rome now contained four hills within its compass, viz. the Palatinus, Tarpeius, Quirinalis, and Cœlius. In the valleys between these hills the rain water and springs uniting formed great pools which laid under water the streets and public places. The mud made the way impassable, and rendered the city unhealthy. Tarquin freed the city from this nuisance, by conveying off these waters by subterraneous channels into the Tiber. In doing this it was necessary to cut, through hills and rocks, a channel large enough for a navigable stream, and covered with arches strong enough to bear the weight of houses, which were frequently built upon them. All these arches were made of hard stone, and neither trouble nor expense was spared to make the work durable. Their height and breadth were so considerable that a cart loaded with hay could easily pass through them under ground. The expense of constructing these sewers was never so thoroughly understood as when it became necessary to repair them: for then the censors gave no less than 1000 talents to the person appointed for this purpose. Besides these great works, Tarquin adorned the forum, surrounding it with galleries, in which were shops for tradesmen, and building temples in it for the youth of both sexes, and halls for the administration of public justice. He next engaged in a war with the Sabines, on pretence that they had assisted the Etrurians. Both armies took the field, and came to an engagement on the confines of Sabinia, without any considerable advantage on either side; neither was any thing of consequence done during the whole campaign. Tarquin, then considering with himself that the Roman forces were very deficient in cavalry, resolved to add some new bodies of knights to those already instituted by Romulus. But this project met with great opposition from the superstitious augurs, as the original division of horse into three bodies had been determined by auguries; and Actius Nævius, the chief of the diviners at that time, violently opposed the king's will. On this occasion credulous historians say that Tarquin, at the word of Nævius, cut a flint with a razor.

This adventure, whatever was the truth of it, caused Tarquin to abandon his design of increasing the number of bodies of horse, and content himself with augmenting the number in each body. He then renewed the war with the Sabines, ravaged their country, defeated them in three pitched battles, obliging them at last to submit to him, and put him in possession of their country. In the decline of life he employed himself in further decorating the city, building temples, &c. He was assassinated in his palace, in the eightieth year of his age, by the sons of Ancus Martius, whom he had originally deprived of the kingdom.

After the death of Tarquin I., his widow Tanquil preserved the kingdom to her son-in-law Servius Tullius, by artfully giving out that

the king was only stunned, and would soon recover; upon which the sons of Ancus went voluntarily into banishment. The second day after his decease, Servius Tullius heard causes from the throne in the royal robes, and attended by the lictors; but as he pretended only to supply the king's place till he should recover, and thought it incumbent on him to revenge the wicked attempt upon his life, he summoned the sons of Ancus to appear before his tribunal; and, on their non-appearance, caused them to be declared infamous, and their estates to be confiscated. After he had thus managed matters for some time, in such a manner as to engage the affections of the people, the death of Tarquin was published as a thing that had newly happened, and Servius Tullius assumed the ensigns of royalty, having none to dispute with him. The new king showed himself every way worthy of the throne. No sooner were the Etrurians informed of Tarquin's death, than they shook off the yoke; but Servius quickly reduced them to obedience, depriving them of their lands, which he shared among the poor Roman citizens who had none. For this he was decreed a triumph by the people, in spite of the opposition of the senate, who could never be brought to approve of his election to the kingdom, though he was soon after legally chosen by the tribes. After Servius had obtained the sanction of the popular voice, he marched a second time against the revolted Etrurians; and, having again vanquished them, was decreed another triumph. He then applied himself to the enlarging and adorning the city. He also added to the city the hills Esquilinus and Viminalis, fixing his own palace on the Esquilinus, to draw inhabitants thither. He likewise added a fourth tribe, which he called Tribus Esquilina, to those instituted by Romulus. He divided also the whole Roman territory into distinct tribes, commanding that there should be at least one place of refuge in each tribe, situated on a rising ground, and strong enough to secure the effects of the peasants in case of a sudden alarm. These strong holds he called pagi, i. e. villages; and he commanded that each of them should have their peculiar temple, tutelary god, and magistrates. In the mean time, his two wards, Lucius Tarquinius and Arunx, the grandchildren of Tarquin I., being grown up, to secure their fidelity, he married them to his daughters. And though the elder of these daughters, who was of a mild and tractable disposition, resembled in character the younger of his pupils, as the elder of his pupils did the younger of his daughters, who was of a violent and vicious temper, yet he thought it advisable to give his elder daughter to Tarquin, and the younger to Arunx; as thus he matched them according to their ages; and hoped that the elder Tullia's sweet disposition would temper Tarquin's impetuosity, and the younger Tullia's vivacity rouse the indolence of Arunx. During the public rejoicing for these marriages, the twelve lucumonies of Etruria, uniting their forces, attempted to shake off the Roman yoke, but were in several battles defeated by Servius, and obliged to submit on the conditions granted by his predecessor. For this success Servius

was honored with a third triumph. The king, being thus disengaged from a troublesome war, put in execution that master-piece of policy which Rome made use of ever after, and which established a perpetual order and regularity in all the members of the state, with respect to wars, the public revenues, and the suffrages of the comitia. The public supplies had hitherto been raised upon the people at so much a head, without any distinction of rich and poor; whence it likewise followed that, when levies were made for the war, the rich and poor were equally obliged to take the field, according to the order of their tribe; and, as they all served at their own expense, the poorer sort could hardly bear the charges of a campaign. Besides, as the most indigent of the people saw themselves burdened with the same taxes as the rich, they pretended to an equal authority in the comitia; so that the election of kings and magistrates, the making of peace or war, and the judging of criminals, were given up into the hands of a populace who were easily corrupted, and had nothing to lose. Servius formed a project to remedy these evils, and put it in execution, by enacting a law, enjoining all the Roman citizens to bring in an account in writing of their own names and ages, and of those of their fathers, wives, and children. All heads of families were also commanded to deliver in, upon oath, a just estimate of their effects, and to add to it the places of their abode, whether in town or country. Whoever did not bring in an account of his effects was to be deprived of his estate, to be beaten with rods, and publicly sold for a slave. Servius, from these accounts, undertook to ease the poor by burdening the rich, and to please the latter by increasing their power. To this end he divided the Roman people into six classes; the first class consisted of those whose estates and effects amounted to the value of 10,000 drachmæ, or 100,000 asses of brass; the first way of computing being used by the Greeks, and the latter by the Latins. This class was subdivided into eighty centuries, or companies of foot. To these Servius joined eighteen centuries of Roman knights, who fought on horseback; and appointed this body of horsemen to be at the head of the first class, because the estates of these knights exceeded the sum necessary to be admitted into it. However, the public supplied them with horses; for which a tax was laid upon widows, who were exempt from all other tributes. This first class, including infantry and cavalry, consisted of ninety-eight centuries. The second class comprehended those whose estates were valued at 7500 drachmæ, or 75,000 asses of brass. It was subdivided into twenty centuries, all foot. To these were added two centuries of carpenters, smiths, and other artificers. In the third class were those who were esteemed worth 5000 drachmæ, or 50,000 asses. This class was subdivided into twenty centuries. The fourth class was those whose effects were rated at the value of 2500 drachmæ, or 26,000 asses, and was divided into twenty centuries; to which were added two other centuries of trumpeters and blowers of the horn, who supplied the whole army with this martial music.

The fifth class included those whose substance did not amount to more than 1250 drachmæ, or 12,500 asses; and this class was divided into thirty centuries. The sixth class comprehended all those who were not worth so much as those of the fifth class; they exceeded in number any other class, but nevertheless were reckoned but as one century. The king drew from these regulations all the advantages he had expected. Levies for the army were no longer raised by tribes, nor were taxes laid on at so much a head, but all was levied by centuries. When an army of 20,000 men, or a large supply of money, was wanted for the war, each century furnished its quota both of men and money; so that the first class, which contained more centuries, though fewer men, than all the others together, furnished more men and more money for the public service than the whole Roman state besides. And by these means the Roman armies consisted for the most part of the rich citizens of Rome; who, as they had lands and effects to defend, fought with more resolution, while their riches enabled them to bear the expense of the campaign. As it was but just the king should make the first class amends for the weight laid on it, he gave it almost the whole authority in public affairs, changing the comitia by curiæ, in which every man gave his vote, into comitia by centuries, in which the majority was not reckoned by single persons, but by centuries, how few soever there might be in a century. Hence the first class, which contained more centuries than the other five taken together, had every thing at its disposal. The votes of this class were first taken; and if the ninety-eight centuries happened to agree, or only ninety-seven of them, the affair was determined; because these made the majority of the 193 centuries which composed the six classes. If they disagreed, then the second, the third, and the other classes in their order were called to vote, though there was very seldom any occasion to go so low as the fourth class for a majority of votes; so that, by this good order, Servius brought the affairs of the state to be determined by the judgment of the most considerable citizens, who understood the public interest much better than the blind multitude, liable to be imposed upon and easily corrupted. And now the people being divided into several orders, according to the census or valuation of their estate, Servius resolved to solemnise this prudent regulation by some public act of religion, that it might be the more respected and the more lasting. Accordingly all the citizens were commanded to appear, on a day appointed, in the Campus Martius, a large plain lying between the city and the Tiber, formerly consecrated by Romulus to the god Mars. Here, the centuries being drawn up in battalia, a solemn lustration or expiatory sacrifice was performed in the name of all the people. The sacrifice consisted of a sow, a sheep, and a bull, whence it took the name of *suovetaurilia*. The whole ceremony was called *lustrum*, a *luendo*; that is, from praying, expiating, clearing, or perhaps from the goddess *Lua*, who presided over expiations, and to whom Servius had dedicated a temple. The king, considering that in

the space of five years there might be such alterations in the fortunes of private persons as to entitle some to be raised to a higher class and reduce others to a lower, enjoined that the census should be renewed every five years.

As the census was usually closed by the *lustrum*, the Romans henceforth began to compute time by *lustrums*, each *lustrum* containing the space of five years. However, the *lustrums* were not always regularly observed, but often put off, though the census had been made in the fifth year. Some writers say that *Servius* at this time coined the first money that had appeared at Rome. The government of the city being thus established, *Servius*, touched with compassion for those whom an unsuccessful war had reduced to slavery, thought that such of them as had, by long and faithful services, deserved and obtained their freedom, were much more worthy of being made Roman citizens than foreigners who were admitted without distinction. He therefore gave the freed men their choice, either to return to their own country or continue at Rome. Those who chose to continue he divided into four tribes, and settled them within the city; and though they were distinguished from the plebeians by their old name of *liberti*, or freed men, yet they enjoyed all the privileges of free citizens. The senate took offence at the regard which the king showed to such low people, who had but lately shaken off their fetters; but *Servius*, by a most humane and judicious discourse, entirely appeased the fathers, who passed his institution into a law which subsisted ever after. This wise king, having thus established order among the people, undertook at last to reform the royal power itself; his equity, which was the main spring of all his resolutions, leading him to act contrary to his own interest, and to sacrifice one-half of the royal authority to the public good. His predecessors reserved to themselves the cognizance of all causes, public and private; but *Servius*, finding the duties of his office too much for one man to discharge well, committed the cognizance of ordinary suits to the senate, and reserved that only of state crimes to himself. All things being now regulated, both in the city and country, *Servius* formed a scheme for attaching the Sabines and Latins to the Romans, by social ties, strengthened by religion. He summoned the Latin and Sabine cities to send their deputies to Rome, to consult about an affair of great importance. When they were come, he proposed to them the building of a temple in honor of *Diana*, where the Latins and Sabines should meet once a-year, and join with the Romans in offering sacrifices to that goddess; that this festival should be followed by a council in which all disputes between the cities should be amicably determined; that there proper measures should be taken to pursue their common interest; and lastly, in order to draw the common people thither, a fair should be kept, at which every one might furnish himself with what he wanted. The king's design met with no opposition: the deputies only added to it that the temple should be an inviolable asylum for the united nations; and that all the cities should contribute toward the expense of building it. It being left to the

king to choose a proper place for it, he pitched upon the *Aventine Hill*, where the temple was built, and assemblies annually held in it. The laws which were to be observed in these general meetings were engraved on a pillar of brass, and were to be seen in *Augustus's* time in the Latin tongue, but in Greek characters. But now *Servius* was grown old; and the ambition of *Tarquin* his son-in-law increased in proportion as the king advanced in years. His wife used her utmost endeavours to check the rashness and fury of her husband, and to divert him from all criminal enterprises; while her younger sister was ever instigating *Arunx*, who placed all his happiness in a private life, to the most villainous attempts. She was continually lamenting her fate in being tied to such an indolent husband, and wishing she had either continued unmarried, or were a widow. Similitude of temper and manners formed by degrees a great intimacy between her and *Tarquin*. At length she proposed nothing less to him than the murdering of her father, sister, and husband, that they two might meet and ascend the throne together. Soon after they paved their way to an incestuous marriage, he by poisoning his wife, and she her husband; and then had the assurance to ask the king's and queen's consent to their marriage. *Servius* and *Tarquinius*, though they did not give it, were silent, through too much indulgence to a daughter in whom now was their only hope of posterity. But these criminal nuptials were only the first step towards a yet greater iniquity. The wicked ambition of the new married couple first showed itself against the king: for they publicly declared that the crown belonged to them; that *Servius* was a usurper, who, being appointed tutor to *Tarquin's* grandchildren, had deprived his pupils of their inheritance; that it was high time for an old man, who was but little able to support the weight of public affairs, to give place to a prince who was of a mature age, &c. The patricians, whom *Servius* had humbled during the whole of his reign, were easily gained over to *Tarquin's* party; and by the help of money, many of the poorer citizens were also brought over. The king, being informed of their treasonable practises, endeavoured to dissuade his daughter and son-in-law from such proceedings, which might end in their ruin; and exhorted them to wait for the kingdom till his death. But they, despising his counsels and paternal admonitions, resolved to lay their claim before the senate, which *Servius* was obliged to summon. *Tarquin* reproached his father-in-law with having ascended the throne without a previous interregnum; and with having bought the votes of the people, and despised the suffrages of the senate. He then urged his own right of inheritance to the crown, and the injustice of *Servius*, who, being only his guardian, had kept possession of it, when he himself was of an age to govern. *Servius* answered that he had been lawfully elected by the people; and that, if there could be an hereditary right to the kingdom, the sons of *Ancus* had a much better one than the grandsons of the late king, who must himself have been a usurper. He then referred the whole to an assembly of the people; which being

immediately proclaimed, all over the city, the forum was soon filled; and Servius harangued the multitude in such a manner as gained all their affections. They all cried out with one voice, 'Let Servius reign; let him continue to make the Romans happy.' Amidst their clamors, these words were likewise heard: 'Let Tarquin die; let him perish.' This language so frightened him, that he retired to his house in great haste; while the king was conducted back to his palace with the acclamations of the people. The ill success of this attempt cooled Tarquin's ardent desire of reigning, but his ambition made him act a new part. He undertook to regain the favor of his father-in-law by caresses, submissions, and protestations of a sincere regard and affection for him; insomuch that the king was sincerely reconciled to him, and tranquillity re-established in the royal family. But it was not long ere Tarquin, roused by the continual reproaches of his wife, began to renew his intrigues; and had no sooner gained a considerable party, than he clothed himself in the royal robes, and, causing the fasces to be carried before him by some of his domestics, crossed the forum, and, entering the temple where the senate used to meet, seated himself on the throne. Such of the senators as were in the faction he found already in their places (for he had given them private notice to be there early); and the rest, being summoned to assemble in Tarquin's name, made what haste they could to the appointed place, thinking that Servius was dead, since Tarquin assumed the title and functions of king. When they were all assembled, Tarquin made a long speech, reviling his father-in-law, and repeating the invectives against him which he had so often uttered, calling him a slave, an usurper, a favorer of the populace, and an enemy to the senate and patricians. While he was speaking Servius arrived; and, rashly giving way to the motions of his courage, without considering his strength, drew near the throne to pull Tarquin down from it. This raised a tumult in the assembly, which drew the people into the temple; but nobody ventured to part the rivals. Tarquin, therefore, being more strong and vigorous, seized the old man by the waist, and, hurrying him through the temple, threw him down from the top of the steps into the forum. The king raised himself up with some difficulty: but all his friends had abandoned him; two or three of the people only, touched with compassion, lent him their arms to conduct him to the palace. As they were leading him on so slowly, the cruel Tullia appeared in the forum, whither she had hastened in her chariot on the first report of what had passed in the senate. She found her husband on the top of the steps of the temple; and was the first who saluted him king. The example was immediately followed by the senators of Tarquin's party. Nor was this enough for the unnatural daughter; she took aside her husband, and suggested to him that he would never be safe so long as the usurper of his crown was alive. Hereupon Tarquin instantly despatched some of his domestics to take away the unfortunate Servius's life. The orders for this parricide were no sooner given than Tullia

mounted her chariot again, with an air of triumph, to return home. In the way to her house, which was through a narrow street, called Vicus Cyprius, the assassins had left the king's body, which was still panting. At this sight the charioteer, struck with horror, checked his horses: but Tullia forced him to go on: and the blood of the father is said to have dyed the wheels of the chariot, and even the clothes of the inhuman daughter; whence the street was called ever after Vicus Sceleratus.

The new king proved a most despotic and cruel tyrant; and was surnamed the proud, on account of his haughty behaviour. All controversies whatever were decided by himself and his friends; and he banished, fined, and even executed, whom he pleased. The census and lustrum, the division of citizens into classes and centuries, were abolished; and all kinds of assemblies, even those for amusement and recreation, were prohibited. Nay, to such a height did Tarquin carry his insolence and tyranny, that the most virtuous of the senators went into voluntary banishment; while many of those who remained were cut off on various pretences, that the king might enjoy their estates. Tarquin, sensible of the danger in which he stood by thus losing the affections of his people, provided a sufficient number of soldiers, by way of guard, to prevent attempts upon his person; and gave his daughter to Octavius Mamilius, one of the most considerable men among the Latins, to strengthen his interest by a foreign alliance. Mamilius accordingly procured many friends to his father-in-law, but he had nearly lost them again by his haughty behaviour. He desired the Latins to call a national council at Ferentinum, where he would meet them on a day appointed by himself. The Latins accordingly met; but, after waiting for several hours, Tarquin did not appear. On this, one Turnus Herdonius, an enterprising and eloquent man, who hated Tarquin, and was jealous of Mamilius, made a speech, in which he inveighed against the haughty behaviour of Tarquin, set forth the contempt which he had put upon the Latins, and concluded with desiring the council to break up and return home without taking any further notice of him. Mamilius, however, prevailed upon them to return the day following; when Tarquin made his appearance, and told the assembly that his design in calling them together was to claim his right of commanding the Latin armies, which he said was derived from his grandfather, but which he desired to be confirmed to him by them. These words were scarcely out of his mouth, when Herdonius, rising up, entered into a detail of Tarquin's tyranny and arbitrary behaviour at Rome, which, he said, the Latins would soon feel in an equal degree; if they complied with Tarquin's demand. To this speech the king made no reply at that time, but promised to answer him next day. In the mean time, however, he bribed the domestics of Herdonius to admit among his baggage a large quantity of arms: and then, telling the Latins that Herdonius's opposition proceeded only from Tarquin's having refused him his daughter in marriage, accused him of having laid a plot to cut off all the de-

puties there present, and to usurp a jurisdiction over the Latin cities; as a proof of which he appealed to the arms hid among the baggage of Herdonius. The accused, conscious of his innocence, desired that his baggage should be searched; which being accordingly done, and the arms found, he was hurried away without being allowed to make any defence, and thrown into a basin at the head of the spring of Ferentinum, where he was drowned. In consequence of this treachery, Tarquin was looked upon by the Latins as their deliverer, and declared general of the Latin armies; soon after which the Hernici and two tribes of the Volsci entered into an alliance with him. To keep these confederates together, Tarquin, with their consent, erected a temple to Jupiter Latiaris on a hill near the ruins of Alba, where he appointed certain feasts called *Feræ Latinæ* to be held on the 27th of April, where the several nations were to sacrifice together, and on no account to commit hostilities against each other during their continuance. The king then proceeded to make war on the rest of the Volsci who had refused to enter into an alliance with him. Some depredations which they had committed in the territories of the Latins served for a pretence to begin the war; but, as Tarquin had no confidence in the Romans, his army was composed only of a small body of them, who were incorporated among the Latin auxiliaries. However, he defeated the enemy, took one of their cities by storm, and gave the booty to his soldiers. He next turned his arms against the Sabines, whom he entirely defeated in two engagements, and made the whole nation tributary; for which exploits he decreed himself two triumphs, and on his return to Rome employed the populace in finishing the sewers and circus which had been begun by his grandfather Tarquin I. In the mean time, Tarquin's persecutions of his own subjects daily drove some of the most considerable into banishment. A great number of patricians took refuge in Gabii, a city of Latium, about thirteen miles from Rome; where the inhabitants, touched with compassion for their misfortunes, not only received them with kindness, but began a war with Tarquin on their account.

The Gabini seem to have been the most formidable enemies whom the Romans had hitherto met with; since Tarquin was obliged to raise a prodigious bulwark to cover the city on the side of Gabii. The war lasted seven years; during which time, by the devastations committed by the two armies, a great scarcity of provisions took place in Rome. The people grew clamorous: and Tarquin, being unable either to quiet them or to reduce the Gabini, fell upon the following dishonourable and treacherous expedient:—His son Sextus pretended to be on very bad terms with his father, and openly inveighed against him; on which he was proclaimed a rebel, and publicly beaten in the forum. This being reported at Gabii, by persons sent thither on purpose, the inhabitants became very desirous of having Sextus among them; and accordingly he soon went thither, having previously obtained a solemn promise from the inhabitants never to deliver

him up to his father. Here he made frequent inroads into the Roman territories, and always came back laden with spoil, his father sending against him only such weak parties as must infallibly be worsted. By this means he soon came to have such a high degree of credit among the Gabini that he was chosen general of their army. Finding his authority sufficiently established, he despatched a slave to his father for instructions; but Tarquin, unwilling to return an explicit answer, took the messenger into the garden, where he struck off the heads of the tallest poppies. Sextus understood that by this hint the king desired him to put to death the leading men in the city of Gabii, which he immediately did; and, while the city was in confusion on account of this massacre, he opened the gates to his father, who took possession of it. The inhabitants dreaded every barbarity from the haughty tyranny of the Roman monarch: however on this occasion he consulted his policy rather than his revenge; granted them their life, liberty, and estates, and even entered into a treaty of alliance with them. The articles were written on the hide of an ox, which was extant in the time of Augustus, in the temple of Jupiter Fidius.

After this he made his son Sextus king of Gabii; sending off his two other sons, Titus and Arunx, the one to build a city at Signia, the other at Cicæum, a promontory of the Tyrrhene Sea, to keep the Volsci in awe; and for some time Tarquin enjoyed a profound peace; the Romans being accustomed to oppression, and the yoke of an imperious master, making no opposition to his will. During this interval Tarquin met with the celebrated adventure of the Sibyl, whose books were ever afterwards held in high estimation at Rome, and Tarquin appointed two persons of distinction to take care of them. These were called *Duumviri*: but their number was afterwards increased to ten, when they were called *Decemviri*; and then to fifteen, when they were termed *Quindecimviri*. At this time also the written civil law had its origin among the Romans, all the statutes enacted by the kings being collected into one body; which, from Papirius, the name of the collector was called the *Papirian law*. The temple of the capitol was also finished; for which purpose the most skilful architects and workmen were brought from Etruria, the populace being obliged to serve them in the most laborious parts. We now come to the important revolution which put an end to the regal power at Rome, and introduced a republican form of government, to which this city is allowed to owe the greatest part of her grandeur. Tarquin had left himself no friends among the rich citizens, by reason of his oppressions; and the populace were equally disaffected on account of their being obliged to labor in his public works. Among the many persons of distinction who had been sacrificed to the avarice or suspicions of Tarquin was M. Junius, who had married the daughter of Tarquin I. This nobleman had a son named L. Junius, who escaped the cruelty of the tyrant by pretending to be an idiot, and hence received the agnomen of Brutus. Soon after the finishing of the works



above mentioned, a violent plague happening to break out at Rome, Tarquin sent his sons Titus and Arunx to consult the oracle of Delphi; and the princes took Brutus along with them, to divert themselves with his supposed folly. Brutus chose for his offering to the Delphic Apollo a stick of elder; which occasioned much laughter. However, he had the precaution to enclose a rod of gold within the stick; and to this probably it was owing that the priestess gave the princes the following riddle, that he who should first kiss his mother should succeed Tarquin in the government of Rome. This answer had been given to their enquiries concerning the succession; upon which the two brothers either drew lots which of them should kiss their mother at their return, or agreed to do it at once, that both might reign jointly: but Brutus, imagining the oracle had another meaning, fell down and kissed the earth, the common mother of all living. This the priestess had probably meant, and had given the answer on purpose to have another proof of Brutus's ingenuity. On the return of the princes to Rome, they found their father engaged in a war with the Rutuli. The treasury being exhausted by the sums which Tarquin had expended in his public works, he had marched to Ardea the capital of that nation, which lay about twenty miles from Rome, in hopes of taking it without opposition. Contrary to his expectation, however, he was obliged to besiege it in form; and this constrained him to lay a heavy tax upon his subjects. As the siege was carried on very slowly, the general officers frequently made entertainments for one another. One day, when Sextus Tarquinius was entertaining his brothers, the conversation happened to turn upon their wives: every one extolled the good qualities of his own; but Collatinus bestowed such extravagant praises on his Lucretia, that the dispute ended in a kind of quarrel. It was then resolved that they should mount their horses and surprise their wives by their unexpected return. The king's daughters-in-law were employed in feasting and diversion, and seemed much disconcerted by the appearance of their husbands; but Lucretia, though the night was far advanced, was found, with her maids about her, spinning and working in wool. She was not at all discomposed by the company whom her husband brought with him, and they were all pleased with the reception she gave them. As Lucretia was very beautiful, Sextus Tarquinius conceived a passion for her, which resolving to satisfy at all events, he soon returned to Collatia in the absence of Lucretia's husband, and was entertained by her with great civility and respect. In the night-time he entered Lucretia's apartment, and threatened her with immediate death if she did not yield to his desires. But finding her not to be intimidated, he told her that, if she still persisted in her refusal, he would kill one of her male slaves, and lay him naked by her when she was dead, and then declare to all the world that he had only revenged the injury of Collatinus. On this the virtuous Lucretia (who, it seems, dreaded violation less than infamy) submitted to the desires of Sextus; but resolved not to outlive his violence. She

dressed herself in mourning, and took a poison under her robe, having previously written to her husband to meet her at her father Lucretia's house, where she refused to discover the cause of her grief, except in a full assembly of her friends and relations. Here, addressing herself to her husband Collatinus, she acquainted him with the whole affair; exhorted them to revenge the injury; and protested that she would not outlive the loss of her honor. Every present gave her a solemn promise that they would revenge her quarrel; but, while they endeavoured to comfort her, she suddenly stabbed herself in the heart, with the dagger which she had concealed. This action inflamed, beyond measure, the minds of all present. Brutus, laying aside his pretended folly, drew the bloody dagger out of Lucretia's body; and, showing it to the assembly, swore by the blood upon it that they would pursue Tarquin and his family with fire and sword; nor would he ever suffer that or any other family to reign in Rome. The same oath was taken by all the company; who were much surprised at the apparent transition of Brutus from folly to wisdom, that they did whatever he desired of them. By his advice the gates of the city were shut, that no one might go out of it to inform Tarquin of what was going forward; which, as Lucretia had been left governor of the city by Tarquin, was put in execution without difficulty. The corpse of Lucretia was then exposed to public view, and Brutus having made a speech to the people in which he explained the mystery of his conduct in counterfeiting folly for many years, proceeded to tell them that the patricians were come to a resolution of deposing the tyrant; and exhorted them to concur in the same deed. The people testified their approbation, and went out for arms; but Brutus did not think proper to trust them with arms till he had first obtained a decree of the senate. This was easily procured, the senate enacted that Tarquin had forfeited the prerogatives belonging to the regal authority, condemned him and all his posterity to perpetual banishment, and devoted to the gods of every Roman who should hereafter, by word or deed, endeavour his restoration; and this decree was unanimously confirmed by the curia.

Tarquin being thus deposed, the form of government became the next object. Lucretia was declared Interrex; but Brutus, being consulted, declared, that though it was the best means proper for the state to be without supreme magistrates, yet it was equally necessary that the power should not be centered in a man, and that it should not be perpetual. For this reason he proposed that two magistrates called consuls, should be elected annually, that the state should thenceforth have the name of a republic; that the ensigns of royalty should be abolished; and that the only ensigns of dignity should be an ivory chair, a white robe, and twelve lictors for their attendants. He proposed that the title of rex, or king, should be given to him who superintended religious matters, who should thenceforth be called *rex sacrorum*, or king of sacred things. This selection being approved of, Brutus and Collatinus

proposed by Lucretius as the two first consuls, and unanimously accepted by the people, who thought it impossible to find more implacable enemies to the Tarquins. They entered on their office A. A. C. 508; and the monster Tullia, perceiving that now all was lost, left the city, and retired to her husband at Ardea. She was suffered to depart, though the populace hooted at her, and cursed her as she went along. Tarquin, in the mean time, being informed by some who had got out of Rome before the gate was shut, that Brutus was raising commotions to his prejudice, returned in haste to the city, attended only by his sons and a few friends; but finding the gates shut, and the people in arms on the walls, he returned again to the camp: here again, to his surprise, he found that the consuls had taken the opportunity of gaining over the army to their interest; so that, being refused admittance into the camp also, he was forced to fly for refuge, at the age of seventy-six, with his wife and three sons to Gabii. Here he continued for some time; but, not finding the Latins forward to revenge his cause, he retired into Etruria; where, it being the country of his mother's family, he hoped to find more friends. The Romans now congratulated themselves on their happy deliverance from tyranny. However, as Tarquin had by his policy procured himself many friends abroad, these now became enemies to the Roman name; and, by the defection of the allies, the Roman dominions were left in much the same state as they had been in the time of Romulus. Though almost constantly victorious in war for 143 years, they had not yet gained land enough to supply their city with provisions. The main strength of the state lay in the number of the citizens of Rome; which, by transplanting the inhabitants of the conquered cities, had so prodigiously increased, that it put the Romans in a condition of usurping the authority over other nations, the most inconsiderable of which had an extent of territory far exceeding theirs. By frequent depredations they so harassed the states of Latium and Etruria that many of them were constrained to enter into treaties with Rome, by which they obliged themselves to furnish her with auxiliaries whenever she should invade and pillage the lands of her other neighbours. Submissions of this kind the Romans called making alliances with them, and these useful alliances supplied the want of a large territory; but now, upon the change of her government, all the allies of Rome forsook her at once, and either stood neuter, or espoused the cause of the banished king. The new consuls in the mean time took the most effectual methods for securing the liberties of the republic. The army employed in the siege of Ardea marched home under Herminus and Horatius, who concluded a truce with the Ardeates for fifteen years. The consuls then again assembled the people by centuries, and had the decree of Tarquin's banishment confirmed; and many of the laws of Servius Tullius were revived to the great joy of the people. Tarquin, however, having made Tarquinii the seat of his residence, engaged the inhabitants to send an embassy to Rome, with a submissive letter for himself, di-

rected to the Roman people. The ambassadors represented in such strong terms to the senate how reasonable it was to let the king be heard before he was condemned, that the consuls inclined to bring these agents before the people, and to leave the decision to the curiæ; but Valerius, who had been very active in the revolution, strenuously opposed this, and by his influence in the senate got it prevented. Mean time, Tarquin prevailed on the inhabitants of Tarquinii to send a second embassy to Rome, demanding the estates of the exiles, but with private instructions to get the consuls assassinated. The restoration of the estates of the exiles was opposed by Brutus, but Collatinus was for complying with it; whereupon Brutus accused his colleague of treachery, and of a design to bring back the tyrant. The matter was referred to the people, where it was carried by one vote in favor of the Tarquins. But whilst the people were employed in loading carriages with the effects of the exiles, and in selling what could not be carried off, the ambassadors drew some of the nearest relations of the consuls into a plot with them. These were three young noblemen of the Aquilian family (the sons of Collatinus's sister), two of the Vitellii (whose sister Brutus had married); and Titus and Tiberius, the two sons of Brutus. They all bound themselves by solemn oaths, with the dreadful ceremony of drinking the blood of a murdered man and touching his entrails. They met at the house of the Aquilii, where they wrote letters to Tarquin and gave them to the ambassadors. But their proceedings were overheard by one Vindicius a slave, who immediately communicated the whole to Valerius; upon which all the criminals were apprehended. Brutus stood judge over his own sons; and notwithstanding the intercession of the whole assembly, and the tears of his children, commanded them to be beheaded; nor would he depart till he saw the execution of the sentence. Having performed this piece of heroic barbarity, he quitted the tribunal, and left Collatinus to perform the rest.

Collatinus, being inclined to spare his nephews, allowed them a day to clear themselves: and caused Vindicius, the only witness against them, to be delivered up to his masters. This roused the indignation of the people, especially of Valerius, who had promised to protect the witness, and therefore he refused to deliver him up to the lictors. The multitude called for Brutus to return; which when he had done, he told them that he had executed his two sons in consequence of his own paternal authority, but that it belonged to the people to determine the fate of the rest. Accordingly, by a decree of the curiæ, all the delinquents suffered as traitors, except the ambassadors. Vindicius had his liberty granted him; and was presented with 25,000 asses of brass, in value about £80 14s. 7d. of our money. The decree for restoring the estates of the exiled Tarquins was annulled, their palaces were destroyed, and their lands divided among the people. The public only retained a piece of ground near the Campus Martius, which the king had usurped, and which they consecrated to Mars. The severity of Brutus towards his two sons

struck such terror into the Romans, that scarcely any person durst oppose him; and therefore he openly accused Collatinus before the people, and without ceremony deposed him from the consulship, banishing him at the same time from Rome. The multitude refused to hear Collatinus in his own defence; so that the consul was on the point of being driven out with ignominy and disgrace, when Lucretius interposed, and prevailed upon Brutus to allow his colleague to resign his fasces, and retire. Brutus then, to remove all suspicions of personal enmity, procured him a present of twenty talents out of the public treasury, to which he added five of his own. Collatinus then retired to Lavinium, where he lived in peace, and died of old age. Valerius was chosen in his room; and the two consuls lived in great harmony. But Tarquin first engaged the Volsci and Tarquinienses to join their forces to support his rights. Brutus commanded the horse and Valerius the foot. The two armies having met, Brutus advanced with his cavalry, at the same time that Arunx was coming forward with the enemy's horse, the king following with the legions. Arunx no sooner discovered Brutus than he made towards him with all the fury of rage. Brutus advanced towards him with no less speed; and as both were actuated only by motives of hatred, without thoughts of self-preservation, both were pierced through with their lances. The battle continued with the utmost fury till night, when it could not be known which side had got the victory, or which had lost the greatest number of men. The Volsci returned home, and Valerius, having caused the dead to be numbered, found that they had lost 11,300 men, and the Romans only one short of that number. Valerius being left without a colleague in the consulship, and having delayed to choose one, began to be suspected of aspiring at the sovereignty; and these suspicions were countenanced by his building a fine house on the steep part of the hill Palatinus. But of this Valerius was no sooner informed than he caused this house to be pulled down, and immediately called an assembly of the people for the election of a consul, in which he left them entirely free. They chose Lucretius; and complimented Valerius with a large ground plot, where they built him a house. The new consul died a few days after his promotion, so that Valerius was once more left sole governor. In this interval, Valerius gave the people so many striking proofs of his attachment to their interest, that they bestowed upon him the surname of Poplicola, or popular. When Poplicola's consulship expired, the Romans elected him a second time, and joined with him T. Lucretius, the brother of Lucretia. They began by restoring the census and lustrum; and found the number of Roman citizens above puberty to be 130,000. A haughty embassy was received from Porsena king of Clusium in Etruria, commanding them either to take back the Tarquins to Rome, or to restore them to their estates. To both these demands the consuls returned an absolute refusal. The imminent danger of the city procured Valerius a third consulship; and with him was joined Horatius Pul-

vilius. While the Romans were making the most vigorous preparations, Porsena, attended by his son Arunx and the exiles, marched towards the city at the head of a formidable army, which was quickly joined by a body of Latins under Valerius, the son-in-law of Tarquin. The consuls, and the senate took all imaginable care to supply the common people with provisions, and ordered the country people to lodge their effects in the fort Janiculum, the only fortified place possessed by the Romans on that side the Tiber. Porsena, however, soon drove the Romans out of this fort; upon which the consuls made all their troops pass the river, to defend the bridge, and Porsena advanced to engage them. The victory was long doubtful; but at last the Romans, led by Horatius Cocles, nephew to the consul, with Valerius Lartius and T. Herminius, who had commanded the right wing, posted themselves at the entrance of the bridge, and for a long time bravely defended it: but at last, their defensive arms being broken, they retired; and then Horatius desiring them to advise the consul to retreat from the bridge at the other end, he for a while sustained the attack of the enemy alone. As he was being wounded, and the signal given that the bridge was almost broken down, he leaped into the river, and swam across it through a shower of darts. The Romans, for this eminent service, erected a statue to him in the temple of Vulcan, and gave him as much land as he, with one yoke of oxen, could plough in one day; and ordered the inhabitants, to the number of 300,000, to give him the value of as much food as each consumed in a day. The city was not yet fully recovered, but it was very difficult to find provisions for so great a multitude. Porsena, hearing of their necessities, told them that he would supply them with provisions if they would take back their old masters; but to this they replied that hunger was less evil than slavery. But the constancy of the Romans was on the point of falling when a young patrician, named Mutius Cordus, with the consent of the senate and consuls, undertook to assassinate Porsena. He got access to the Etrurian camp, and made his way to the king's tent. It happened to be the day on which the king's troops were reviewed, and Porsena's secretary, who was then sitting on the same tribunal with the king. Mutius, mistaking him for Porsena, instantly leaped upon the tribunal, and killed him. He then attempted to escape, but being seized and brought back, he owned his design; and, with a countenance expressive of desperate rage and disappointment, thrust his sword into a hole which had missed the blow into a fire, and held it for a considerable time. On the next day Porsena, changing his resentment into admiration, granted him his life and liberty, and even restored him his dagger. Mutius took it with his right hand, having burnt the other; and from that time had the name of Scævola, or left-hand. He then, to induce Porsena to break the siege, told him that 300 young Romans were so resolute as himself, had sworn to take away the life or perish. This had the desired effect. Porsena sent deputies to Rome, whose commands were that the Romans should restore the estates of the Tarquins, or give them an

lent, and the seven small towns formerly taken from the Veientes. The latter of these demands was cheerfully complied with; and, a truce being agreed on, deputies were sent to the Etrurian camp to plead the Roman cause against the Tarquins, and with them ten young men and ten virgins, as hostages for performing the other article. The reception which Porsena gave the deputies raised the jealousy of the Tarquins; who refused to admit Porsena for a judge between them and the Romans. But the king, without any regard to their opposition, resolved to satisfy himself whether the protection he had given the Tarquins was just. Mean time, news were brought that the young women whom the Romans had sent as hostages had swam across the Tiber, and were returned to Rome. They had gone to bathe in the river, and Clælia, turning her eyes towards Rome, ventured to swim across the river, and encouraged her companions to follow her. The return of the hostages gave Poplicola great uneasiness, lest it should be imputed to want of fidelity in the Romans. To remove all suspicions, he sent a deputation to the Etrurian camp, assuring the king that Rome had no share in the foolish attempt of the young women; and promising to send them immediately back to the camp whence they had fled. Porsena was easily appeased; but, the news of the speedy return of the hostages being known in the camp, the Tarquins, without any regard to the truce, or respect to the king their protector, lay in ambush on the road to surprise them. Poplicola, having put himself at the head of the Roman troops who escorted them, sustained the attack of the Tarquins, though sudden and unexpected, till his daughter Valeria rode full speed to the Etrurian camp, and gave notice of the danger her father and companions were in; when Arunx, the king's son, flying with a body of cavalry to their relief, put the aggressors to the rout. This treachery in the Tarquins gave Porsena a bad idea of their cause. He therefore assembled the chief commanders of the Etrurians; and, having heard in their presence the complaints of the Romans against the Tarquins, he was so struck with horror at the recital of the crimes of the Tarquins that he immediately ordered them to leave his camp, and renounced his alliance with them. He then ordered the ten young virgins to be brought before him, and enquired who was the first author of the enterprise. Clælia, with an air of intrepidity, confessed that she alone was guilty. Upon this the king, extolling her resolution above the bravery of Horatius and Mutius, made her a present of a very fine horse with sumptuous furniture. After this he concluded a peace with the Romans, and restored to them all their hostages, declaring at the same time that their bare word was to him a sufficient security for the performance of the articles.

Porsena, being about to return to Clusium, gave, before his departure, a further testimony of his friendship for the Romans. Knowing that Rome was greatly distressed for want of provisions, he ordered his soldiers to leave behind them their tents and provisions, and to carry nothing with them but their arms. As his camp

abounded with all sorts of provisions, Rome was hereby much relieved. The senate erected a statue of Porsena near the comitium, and sent an embassy to him with a present of a throne of ivory, a sceptre, a crown of gold, and a triumphal robe. Thus the Romans escaped the greatest danger they had hitherto been in. However the Sabines revolted, and continued the war for some time with great obstinacy; but, being defeated in several engagements, they were at last obliged to submit; and scarcely was this war ended when another began with the Latins, who now declared for Tarquin. Before they began this war, however, an embassy was sent to Rome the purport of which was, that the Romans should raise the siege of Fidene which had revolted, and receive the Tarquins: who, on their part, should grant a general amnesty. The ambassadors were to allow the Romans a whole year to consider on these overtures; and to threaten them with a war in case they refused to comply with them. The chief view of Tarquin and his partisans, in promoting this embassy, was to lay hold of that opportunity to raise a sedition in the city. To the ambassadors, therefore, of the Latins, he joined some of his own emissaries, who, on their arrival in the city, found two sorts of people disposed to enter into their measures: to wit, the slaves, and the meaner citizens. The slaves were to murder their masters, and the lower citizens to massacre the patricians. The conspiracy was ripe for execution, when Tarquin's agents and relations, Publius and Marcus Tarquinius, being terrified with frightful dreams, had not courage to proceed in their design till they had consulted a diviner, and asked him what success they might expect in a project they had formed. The soothsayer answered, Your project will end in your ruin; disburden yourselves of so heavy a load. Hereupon, fearing lest some of the other conspirators should be beforehand with them in informing, they went immediately to S. Sulpitius, the consul, and discovered the whole matter. The consul greatly commended them, assembled the senate, and gave the Latin ambassadors their audience of leave, with an answer to their proposals; which was, that the Romans would neither receive the Tarquins nor raise the siege of Fidene, being all ready to sacrifice their lives in defence of their liberties, and willing to undergo any dangers rather than submit to the government of a tyrant. The ambassadors being dismissed, with this answer, Sulpitius laid open to the fathers the dreadful conspiracy. It struck them with horror; but they were all at a loss how they should apprehend and punish the guilty; since, by the law of Poplicola, there was an appeal to the people in all capital cases, and the two witnesses, who were strangers, might be excepted against by Roman citizens. In this perplexity they left the whole conduct of this critical affair to Sulpitius, who took a method which he thought would equally serve to prove the guilt and punish the guilty. He engaged the two informers to assemble the conspirators, and to appoint a rendezvous at midnight in the forum, as if they intended to take the last measures for the execution of the enterprise. In the mean time he used all proper

measures to secure the city, and ordered the Roman knights to hold themselves ready, in the houses adjoining to the forum, to execute the orders they should receive. The conspirators met at the time and place appointed by the two Tarquins; and the knights, upon a signal agreed on beforehand, invested the forum, and blocked up all the avenues to it so closely that it was impossible for any of the conspirators to escape. As soon as it was light the two consuls appeared with a strong guard on the tribunal. The people were convened by curiæ, and told of the conspiracy. The accused were allowed to make their defence, if they had any thing to offer against the evidence: but, not one of them denying the fact, the consuls repaired to the senate, where sentence of death was pronounced against the conspirators. This decree of the senate being read, and approved by the assembly, the conspirators were delivered up to the soldiers, who put them all to the sword. The peace of Rome was thought sufficiently secured by this stroke of severity; and therefore, though all the conspirators were not punished with death, it was judged proper not to make any farther enquiries. The two informers were rewarded with all the privileges of Roman citizens, 100,000 asses, and twenty acres of laud. Three festival days were appointed for expiations, sacrifices, and public games, &c. But as the people were conducting Manlius Tullius, the consul, from the circus, he fell from his chariot, and died in three days. The city of Fidenæ still held out during the following consulship of T. Æbutius and P. Veturius; but was taken the next year by T. Lartius, who, with Q. Clælius, was raised to the consular dignity. The Latins, enraged at the loss of this town, began to complain of their leading men; which opportunity Tarquin and Mamilius improved so far as to make all the Latin cities, twenty-four in number, enter into an alliance against Rome, and to bind themselves by oath never to violate their engagements. The Latins made vast preparations, as did likewise the Romans; but the latter could procure no assistance from their neighbours. To add to their distress the poorer sort of people, and the debtors, refused to serve; alleging their poverty and the fruitless hazards they ran in defending a city where they were oppressed and enslaved by their creditors. This spirit of mutiny spread among the inferior classes, most of them refusing to enlist unless their debts were all remitted by a decree of the senate. The senate assembled to deliberate on these troubles. Some were for a free remission of all debts, as the safest expedient; others urged the dangerous consequences of such a condescension, advising them to enlist only such as were willing to serve. At length it was decreed that all actions for debts should be suspended till the end of the war. But this the indigent debtors thought only a suspension of their misery, and therefore it had not the intended effect. The senate might indeed have prosecuted the ringleaders; but Poplicola's law, called the Valerian law, which allowed appeals to the people, was a protection for the seditious, who were sure of being acquitted. The senate, therefore, to elude the effect of a privilege that put such a restraint upon their power, resolved

to create one supreme magistrate, who, with the title of dictator, should have absolute power for a time; but, at this could not be done without striking at the Valerian law, and transferring the power of the people in criminal cases to a magistrate superior to all law, it was necessary to use artifice to obtain the consent of the curiæ. They therefore represented to them that, in such a crisis, when they had domestic quarrels to decide and a powerful enemy to repulse, it was expedient to put the commonwealth under a single governor, who, superior to the consuls themselves, should be the arbiter of the laws; that his power should have no limits; but, lest he should abuse it, they ought not to trust him with it above six months. The people agreed, not foreseeing the consequences; but the great difficulty was to find a man qualified for so great a trust. T. Lartius, one of the consuls, seemed to be the most unexceptionable; but the senate, fearing to offend his colleague, gave the consuls the power of choosing a dictator, but obliged them to name one of themselves, not doubting but Clælius would yield to the superior talents of his colleague. Lartius, however, with the same readiness, named Clælius; and the only contest was, which of the two should raise the other to the supreme authority. Each persisted obstinately in remitting the dignity to his colleague, till Clælius suddenly abdicated the consulship, and, as an interrex, proclaimed Titus Lartius dictator: who was therefore obliged to take upon him the government of the republic.

Lartius began his administration by creating a general of the Roman horse: an office which lasted only during the dictatorship. Sp. Cassius, formerly consul, and honored with a triumph, was the person advanced to this dignity. Having thus secured the Roman knights, the dictator resolved, in the next place, to make the people respect and fear him. With this view he never appeared in public without being attended by twenty-four lictors, to whose fasces he again added the axes which Poplicola had taken from them. This was alone sufficient to awe the seditious, and, without executions, to spread consternation throughout Rome. He then ordered a census to be taken. Every one brought in his name, age, estate, &c., and there were found to be 150,700 men capable of bearing arms. Out of these the dictator formed four armies: the first he commanded himself; the second he gave to Clælius his late colleague; the third to Sp. Cassius, his general of the horse; and the fourth he stationed at Rome, under his brother Sp. Lartius. The Latins not being forward in their preparations, all their hostilities this campaign amounted only to sending a detachment into the Roman territory to lay it waste. The dictator gained some advantage over this party; and the great humanity with which he treated the prisoners and wounded disposed the Latins to listen to overtures for a suspension of hostilities. A truce was agreed on for a year; when, seeing the republic restored to tranquillity, Lartius resigned the dictatorship. The next consulship of Sempronius Atratinus and Minutius Augurinus produced nothing memorable. But the following year the truce expired, when Aulus Posthumius

and T. Virginius took possession of the consulship. Both Romans and Latins were now busied in preparing for war. The nobility of Latium who were mostly in the interest of the Tarquins, having excluded the citizens from the Latin diets, carried all before them in these assemblies; whereupon many of them removed with their families to Rome. The Latins being bent upon war the senate empowered the two consuls to name one of themselves dictator; and Virginius readily yielded the office to Posthumius, as the more able commander. Having created Æbutius Elva his general of horse, the new dictator divided his army into four bodies, and left one of them, under the command of Sempronius, to guard the city; with the other three, commanded by himself, Virginius, and Æbutius, he marched out against the Latins, who, with an army of 40,000 foot and 3000 horse, under Sextus and T. Tarquinius and Mamilius, had already taken Corbio, a strong hold belonging to Rome. Posthumius encamped on a steep hill near the lake Regillus, and Virgilius on another hill over-against him. Æbutius was ordered to march silently in the night, with the cavalry and light-armed infantry, to take possession of a third hill and intercept the provisions of the Latins. Before Æbutius had fortified his camp, however, he was vigorously attacked by T. Tarquinius, whom he repulsed three times with great loss, the dictator having sent him a reinforcement. After this Æbutius intercepted two couriers sent by the Volsci to the Latin generals, and by their letters discovered that a great army of the Volsci and Hernici were to join the Latin forces in three days. Upon this Posthumius drew his three bodies of troops together, amounting in all to 24,000 foot and 1000 horse, with a design to engage the enemy before the arrival of their succors; and the Latins, who were much superior in numbers, did not decline the engagement. T. Tarquinius, at the head of the Roman exiles and deserters, was in the centre, Mamilius in the right wing, and Sextus Tarquinius in the left. In the Roman army the dictator commanded in the centre, Æbutius in the left wing, and Virginius in the right. The dictator's body first advanced; and, as soon as it began to march, T. Tarquinius, singling out the dictator, ran full speed against him. But the latter wounded him with a javelin in the right side. Upon this the first line of the Latins advanced to cover their general; but, he being carried out of the field, they made but a faint resistance, and began to retire, when Sextus Tarquinius brought them back to the charge, and renewed the fight with such vigor that the victory in the centre was still doubtful. Both parties, encouraged by their leaders, fought with incredible bravery. After a long and bloody contest the two generals agreed to determine the doubtful victory by a single combat. Accordingly Æbutius with his lance wounded Mamilius in the breast; and Mamilius with his sword wounded Æbutius in the right arm. Neither of the wounds was mortal; but, both the combatants falling from their horses, put an end to the combat. Marcus Valerius, the brother of Poplicola, now endeavoured, at the head of the Roman

horse, to break the enemy's battalions; but was repulsed by the cavalry of the Roman royalists. Mamilius appeared again in the van, with a considerable body of horse and light-armed infantry. Valerius, with his two nephews, the sons of Poplicola, and a chosen troop of volunteers, attempted to break through the Latin battalions, to engage Mamilius; but, receiving a mortal wound in his side, fell from his horse, and died. His body was carried off by Poplicola's sons, and delivered to Valerius's servants, who conveyed it to the Roman camp; but the young heroes, being afterwards overpowered by numbers, were both killed on the spot. Upon their death the left wings of the Romans began to give ground, but Posthumius, with a body of Roman knights, flying to their assistance, charged the royalists with such fury that they were, after an obstinate resistance, obliged to retire in confusion. Mean time Titus Horminius, having rallied those who had fled, fell upon some close battalions of the enemy's right wing, which still kept their ground under Mamilius, killed him with his own hand, and put his detachment to flight; but received himself a wound, of which he died soon after. Sextus Tarquinius in the mean time maintained the fight with great bravery, at the head of the left wing, against Virginius; and had even broken through that wing of the Roman army, when the dictator attacked him with his victorious squadrons. Sextus then threw himself in despair into the midst of the Roman knights, and sunk under a multitude of wounds. The death of the three generals was followed by the entire defeat of the Latin army. Their camp was taken and plundered, and most of their troops cut in pieces; for, of the 43,000 men who came into the field, scarcely 10,000 returned home. The next morning the Volsci and Hernici came, according to their agreement, to assist the Latins; but, finding upon their arrival how matters had fallen out, sent ambassadors to the dictator, to congratulate him on his victory, and assure him that they had come to assist the Romans. Posthumius, producing their couriers and letters, showed them, however, that he was apprized of their treachery. But, out of regard to the law of nations, he sent them back unhurt, with a challenge to their generals to fight next day; but the Volsci and their confederates, not caring to engage a victorious army, decamped, and returned to their respective countries. The Latins, having now no alternative but an entire submission, sent ambassadors to Rome, yielding themselves to the judgment of the senate; and, as the Romans had long made it a maxim to spare the nations that submitted, the motion of T. Lartius prevailed; the ancient treaties with the Latins were renewed, on condition that they should restore the prisoners, deliver up the deserters, and drive the Roman exiles out of Latium. Thus ended the last war which the Romans waged on account of their banished king; who, being now abandoned by the Latins, Etrurians, and Sabines, retired into Campania, to Aristodemus, tyrant of Cumæ, and there died in the ninetyeth year of his age, and fourteenth of his exile.

## PART II.

## ROME, REPUBLICAN.

Those domestic feuds now took place which continued more or less during the republic. The first disturbances were occasioned by the oppression of the plebeians who were debtors to the patricians. The senate chose to the consulate Appius Claudius, who violently opposed the pretensions of the plebeians; but gave him for his colleague P. Servilius, of a contrary disposition. The consequence was, that the consuls disagreed; the senate could not determine; and the people were ready to revolt. In the midst of these disturbances, an army of the Volsci advanced: the people refused to serve; and, had not Servilius procured some troops who served out of personal affection, the city would have been in great danger. The Volsci next engaged in alliance with the Hernici and Sabines. Mean time, the disputes at Rome continued with such violence that the plebeians absolutely refused to march against the advancing enemy. In this extremity Servilius promised that, when the Volsci were repulsed, the senate would remit the debts of the plebeians. This having engaged them to serve, the consul marched out at their head, defeated the enemy, and took their capital, giving it up to be plundered by his soldiers. This step of Servilius, however, furnished Appius with a pretence for refusing him a triumph, as a man who aimed at popularity by the excessive indulgence of the army. Incensed at this injustice, and encouraged by the people, Servilius decreed himself a triumph, however, in spite of Appius. After this he marched against the Aurunci, who had entered Latium; and, in conjunction with Posthumius Regillensis, utterly defeated them. But neither the services of the general nor his soldiers could mollify the senate and patricians. Appius even imprisoned all those who had been set at liberty during the war. The prisoners cried for relief to Servilius; but he could not obtain the accomplishment of those promises which the senate never meant to perform. Perceiving therefore that he had thus lost all his interest with the plebeians, he joined the patricians against them; until the former, rushing into the forum, made such a tumult that no sentence pronounced by the judges could be heard, and the utmost confusion prevailed. Several proposals were made to accommodate matters; but, through the obstinacy of Appius, they came to nothing. In the mean time, it was necessary to raise an army against the Sabines; but the people refused to serve. Manlius Valerius, brother to Poplicola, once more prevailed upon them to march; having previously obtained assurances from the senate that their grievances should be redressed. But no sooner had victory declared in favor of the Romans than the senate, apprehending that the soldiers at their return would challenge Valerius, who had been nominated dictator, for the performance of their promises, desired him and the two consuls to detain them in the field. The consuls obeyed; but the dictator, whose authority did not depend on the senate, disbanded his army, and invested 400 of the plebeians with the dignity of knights.

After this he claimed the accomplishment of the promises made by the senate: but mean while, performing them, he had the mortification to hear himself loaded with reproaches; and he resigned his office. No sooner were these transactions known in the army than the soldiers to a man, deserted the consuls and other officers and retired to a hill called afterwards Mons Sacer, three miles from Rome. Here they sent a deputation to the magistrates: but they were treated with contempt. All things seemed to tend to a civil war, when matters were compromised by the insatiation of tribunes of the people, who had power to prevent the passing of any law that might be prejudicial to them and whose persons were declared sacred. All the Romans were to engage themselves and their posterity, never to repeal this law. The people, after these regulations, erected an altar to Jupiter the Terrible, on the top of the hill where their camp had stood; and when they offered sacrifices, and consecrated the spot, their retreat, they returned to Rome, and their new magistrates. Thus the Roman constitution, which had been monarchic, and which had passed into an aristocracy, began to resemble a democracy. The tribunes obtained permission from the senate to elect two plebeians as their assistants, who should ease them of the great multiplicity of their affairs. These were at first called plebeian aediles; and afterwards simply aediles.

The consul Cominius next led an army against the Volsci; defeated them, and took Laurentum Polusca; after which he besieged Coronea, a strongly fortified capital. He carried this place and gained a victory over the Antiates the next day; but Caius Marcius, an eminent patriot, had the glory of both actions. The troops attached by the consul to scale the walls of Coronea being repulsed in their first assault, Marcius rallied them, drove back the enemy from their walls, and, entering the city, made himself master of it. He then put himself in the foremost ranks of the consul's army, just about to engage the Antiates, and there he behaved with equal bravery. The next day the consul erected his tribunal before his tent, called the soldiers together. His whole speech was a panegyric upon Marcius. Putting a crown upon his head, he assigned him a tenth part of the spoil; and, in the name of the republic, gave him a present of a horse finely caparisoned, giving him leave at the same time to choose out of ten of the prisoners for himself; and as much money as he could carry away. Of all the offers, Marcius accepted only the horse, and the captive of the ten, an old friend of his father. The consul now bestowed on him the surname of Coriolanus, thereby transferring from himself to Marcius all the honor of the conquest. On his return to Rome, Cominius disbanded his army; and war was succeeded by works of religion, public games, and treaties of peace. The census and a lustrum closed the events of this memorable consulship. At this period there appeared to be in Rome only 110,000 men fit to bear arms: a number by many thousands less than at the last enrolment, great numbers

fled to avoid being made slaves to their creditors. Under the consulship of T. Geganius and P. Minucius Rome was terribly afflicted by a famine, occasioned chiefly by the neglect of ploughing and sowing during the late troubles; for the sedition had happened after the autumnal equinox. The senate despatched agents into Etruria, Campania, the country of the Volsci, and even into Sicily, to buy corn, when those who embarked for Sicily, having been retarded by a storm, were constrained to pass the winter at Syracuse. At Cumæ, the tyrant Aristodemus seized the money brought by the commissaries; and they themselves with difficulty saved their lives by flight. The Volsci, also, far from being disposed to assist the Romans, would have marched against them, if a sudden and destructive pestilence had not defeated their purpose. In Etruria alone the Roman commissaries met with success. They sent a considerable quantity of grain to Rome in barks; but, this being consumed, the misery became excessive. During this distress a deputation came from Velitræ, a Volscian city, where the Romans had formerly planted a colony, representing that nine parts in ten of its inhabitants had been swept away by a plague, and praying the Romans to send a new colony to re-people it. The senate granted the request, pressed the departure of the colony, and named three leaders to conduct it. The people, however, began to fear that the place might be still infected; and this apprehension became so universal that not one of them would consent to go. On this the senate published a decree that all the citizens should draw lots; and that those to whose lot it fell to be of the colony should instantly march for Velitræ, or suffer the severest punishment; at last, therefore, fear and hunger induced compliance; and the senate a few days after sent a second colony to Norba, a city of Latium. But the patricians were disappointed as to the benefit they expected from these measures. The plebeians who remained in Rome grew more and more disaffected to the senate. At first they assembled in small companies to vent their complaints; and at length, in one great body, rushed into the forum, calling upon the tribunes for help; when these officers did but heighten the general discontent. Spurius Icilius, their chief, inveighed bitterly against the senate; and exhorted others to speak freely their thoughts; calling particularly, and by name, upon Brutus and Sicinius, the ringleaders of the former sedition, now ædiles. These men also added fuel to the fire: and, the more to inflame the spirits of the multitude, enumerated all the past insults which the people had suffered from the nobles. Brutus concluded his harangue with loudly threatening that, if the plebeians would follow his advice, he would soon oblige those who had caused the present calamity to find a remedy for it. The next day the consuls, greatly alarmed, and apprehending from the menaces of Brutus some mischievous event, thought it advisable to convene the senators. Some were for employing soft words and promises. But Appius's advice prevailed, that the consuls should call the people together, assure them that the patricians had not brought upon them the miseries they suffered, and engage on the

part of the senate that all possible care should be taken to provide for their necessities; while they should reprove the disturbers of the public peace. But, when the consuls assembled the people, they were interrupted by the tribunes. A dispute ensued, in which no one could be well understood by the audience. The consuls contended, that, as the superior magistrates, their authority extended to all assemblies of the citizens. On the other hand, it was urged, that the assemblies of the people were the province of the tribunes, as the senate was that of the consuls. The dispute grew warm, and each party was ready to proceed to violence; when Brutus, having put some questions to the consul, closed the assembly. Next day he proposed a law, which was carried, that no person should interrupt a tribune when speaking to the people; by which means the power of the popular party was increased, and the tribunes became formidable opponents both to the consuls and patricians. An opportunity soon offered for the parties to try their strength. A great fleet of ships laden with corn from Sicily, a great part of which was a present from king Gelon to the Romans, and the rest purchased by the senate with the public money, raised their spirits: when Coriolanus incurred their resentment, by insisting that it should not be distributed till the grievances of the senate were removed. For this the tribunes summoned him to a trial before the people. On the day appointed all persons were anxious for the issue, and a vast concourse from the adjacent country assembled at the forum. Coriolanus presented himself before the people with a high degree of intrepidity. His graceful person, his persuasive eloquence, the cries of those whom he had saved from the enemy, inclined the auditors to relent. But being confounded with a new charge, which he did not expect, of having embezzled the plunder of Antium, the tribunes immediately took the votes, and Coriolanus was condemned to exile. This sentence against their bravest defender, struck the whole body of the senate with sorrow and consternation. Coriolanus alone, in the midst of the tumult, seemed unconcerned. He returned home, followed by the lamentations of the most respectable senators and citizens, to take leave of his wife, children, and mother. Thus recommending his children to their care, he left the city, without followers or fortune, to take refuge with Tullus Attius, a man of great power among the Volscians, who took him under his protection, and induced the Volsci to break the league which had been made with Rome. For this purpose Tullus sent many of his citizens thither, to the games then celebrating; but at the same time gave the senate private information that the strangers had dangerous intentions. This had the desired effect; the senate issued an order that all strangers, whoever they were, should depart from Rome at sunset. This order Tullus represented to his countrymen as an infraction of the treaty, and procured an embassy to Rome, complaining of the breach, and demanding back the territories belonging to the Volscians, of which they had been violently dispossessed: a message treated by the senate with contempt. War being declared on both sides, Coriolanus and Tullus were now made genera



of the Volscians; and invaded the Roman territories, laying waste the lands of the plebeians, but leaving those of the senators untouched. Mean time, the levies went on at Rome very slowly; the two consuls, who were re-elected by the people, seemed but little skilled in war, and feared to encounter a general whom they knew to be their superior in the field. The allies also showed their fears, and slowly brought in their succors. Fortune followed Coriolanus in every expedition; and he became so famous for his victories that the Volsci left their towns defenceless to follow him into the field. The very soldiers of his colleague's army came over to him. Thus finding himself unopposed in the field, and at the head of a numerous army, he at length invested the city of Rome. It was then that the senate and the people unanimously agreed to send deputies to him, with proposals of restoration, in case he should draw off his army. Coriolanus received these proposals at the head of his officers, and refused them with the sternness of a general that knew he was to give the law. Another embassy was now sent, conjuring him not to exact from his native city ought but what became Romans to grant. But Coriolanus still persisted in his demands, and granted them but three days to deliberate. All that was left was another deputation more solemn than either of the former, composed of the pontiffs, priests, and augurs. These, clothed in their sacred habits, and with a grave and mournful deportment, issued from the city, and entered the camp of the conqueror: but in vain; they found him severe and inflexible as before. When the people saw them return ineffectually, they gave up the commonwealth as lost. The temples were filled with old men, women, and children, who, prostrate at their altars, put up ardent prayers for the preservation of their country: nothing was to be heard but anguish and lamentation, nothing to be seen but affright and distress. At length it was suggested that what could not be effected by the intercession of the senate, or the abjuration of the priests, might be brought about by the tears of his wife, or the commands of his mother. This measure was approved by all; and the senate itself gave it their sanction. Veturia, the mother of Coriolanus, therefore, undertook the embassy, and set forward from the city, accompanied by the principal matrons of Rome, Volumnia his wife, and his two children. Coriolanus, who at a distance discovered this mournful train of females, was resolved to give them a denial; but, when told that his mother and his wife were among the number, he instantly came down to meet them. At first the salutations and embraces of the interview took away the power of words; and the rough soldier could not refrain from sharing in their distress. Coriolanus seemed much agitated by contending passions; while his mother seconded her persuasive eloquence by sighs and tears: his wife and children hung round him, intreating for protection and pity; and the fair train, her companions, added their lamentations, and deplored their own and their country's distress. The patriot for a moment was silent, feeling the strong conflict between honor and inclination: at length, as if roused from a dream, he flew to take up his

mother, who had fallen at his feet, crying out, 'O my mother, thou hast saved Rome, but lost thy son.' He gave orders to draw off the army, pretending to the officers that the city was too strong to be taken. Tullus, who envied his glory, was not remiss in aggravating the lenity of his conduct. Upon their return, Coriolanus was slain in an insurrection of the people, and afterwards honorably buried, with ineffectual repitance.

The year following, the two consuls of the former year, Manlius and Fabius, were cited by the tribunes to appear before the people. The Agrarian law, which had been proposed some time before, for equally dividing the lands of the commonwealth, was the object invariably pursued, and they were accused of having put it off. The consuls made many delays and excuses, till at length they were obliged to have recourse to a dictator; and they fixed upon T. Quinctus Cincinnatus, a man who had for some time given up all views of ambition, and retired to his little farm, where the deputies of the senate found him holding the plough. He appeared but little elevated with the addresses of ceremony and the pompous habits they brought him; and, upon declaring to him the senate's pleasure, he testified rather a concern that his aid should be wanted. However he departed for the city, where both parties were strongly inflamed against each other, resolved to side with neither. By threats and well timed submission he prevailed upon the tribunes to put off the disputed law for a time, and carried himself so as to be a terror to the multitude. Having thus restored that tranquillity which he so much loved, he again gave up the splendor of ambition, to enjoy his little farm. Cincinnatus was not long retired, however, when a fresh exigence of the state required his assistance. The Æqui and the Volsci, who, though worsted, were still for renewing the war, made new inroads into the territories of Rome. Minutius, one of the consuls who succeeded Cincinnatus, was sent to oppose them; but his army was driven into a defile between two mountains, from which, except through the lines of the enemy, there was no egress. This the Æqui had the precaution to fortify: by which the Roman army was so hemmed in on every side, that nothing remained but submission to the enemy, or famine. Some knights, who found means of getting away privately through the camp of the Volsci, were the first that brought the account of this disaster to Rome. Nothing could exceed the consternation of all ranks. The senate at first thought of the other consul; but, not having sufficient experience of his abilities, they unanimously turned their eyes upon Cincinnatus, and resolved to make him dictator. He was found, as before, by the messengers in the field. Being called upon to nominate his master of the horse, he now chose a poor man named Tarquinius; and, upon entering the city, entreated all those who were able to bear arms to repair before sun-set to the Campus Martius. He put himself at their head, and, marching all night with great expedition, he arrived before day within sight of the enemy. Upon his approach the soldiers raised a loud shout, to apprise the consul's army of the relief that was at

hand; the Æqui, not a little amazed, saw themselves between two enemies; and when they perceived Cincinnatus making the strongest entrenchments beyond them, to prevent their escape, a furious combat ensued; until, attacked on both sides, they begged a cessation of arms. They offered the dictator his own terms; when he gave them their lives, but obliged them, in token of servitude, to pass under the yoke. Their captains and generals he made prisoners. Thus, having rescued a Roman army from inevitable destruction, having defeated a powerful enemy, having taken and fortified their city, and, still more, having refused any part of the spoil, he resigned his dictatorship, after having enjoyed it but fourteen days. The senate would have enriched him; but he declined their offers.

Still this repose from foreign invasions did not lessen the tumults of the city. The clamors for the Agrarian law continued, and raged yet more fiercely, when Sicinius Dentatus came forward, to enumerate his hardships. See DENTATUS. Notwithstanding his speech had great effect on the people, the Agrarian law was postponed by a number of young patricians who made a riot and broke the balloting urns. The republic of Rome had now near sixty years been fluctuating between the contending orders that composed it till, at length each side, as if weary, were willing to respire a while. The citizens, therefore, of every rank, now began to complain of the arbitrary decisions of their magistrates, and wished to be guided by a written body of laws; in which both the senate and the people concurred. It was therefore agreed that ambassadors should be sent to the Greek cities in Italy, and to Athens, to bring home such enactments thence as by experience had been found most equitable; and three senators, Posthumus, Sulpicius, and Manlius, were fixed upon for the commission and galleys assigned to convey them. While they were abroad, a dreadful plague depopulated Rome for about a year. The ambassadors at the close of that period returned, bringing home a body of laws, collected from all the civilized states of Greece and Italy, which being afterwards formed into ten tables, and two more being added, constituted that celebrated code, called the Laws of the Twelve Tables, fragments of which are still extant. The tribunes now required that a body of men should be chosen to digest these laws into proper form. After long debates, whether this choice should not be partly made from the people as well as the patricians, it was at last agreed that ten of the principal senators should be elected, whose power, continuing for a year, should be equal to that of kings and consuls, and their decision final. The persons chosen were Appius and Genutius, who had been elected consuls for the ensuing year; Posthumus, Sulpicius, and Manlius, the three ambassadors; Sextus and Romulus, former consuls; with Julius Veturius, and Horatius, senators of the first consideration. The decemviri, being now invested with absolute power, agreed to take the reins of government by turns, and each to dispense justice for a day. For the first year these magistrates attended their duty with extreme application; and, their work being

finished, it was expected that they would give up office; but, having known the charms of power, they were now unwilling to resign it; and, regardless either of the approbation of the senate or the people, resolved to continue in the decemvirate. A conduct so inconsistent and arbitrary produced discontents; and these again fresh acts of tyranny. The city was become almost a desert, with respect to all who had any thing to lose. Yet not one citizen was sufficiently assured to strike for his country's freedom; these tyrants continued to rule without control, constantly guarded by their lictors, and a numerous crowd of dependents. In this situation of the state, the Æqui and Volsci projected new incursions, and advanced within ten miles of Rome. But the decemviri, being in possession of the military as well as civil power, divided their army into three parts; of which one continued with Appius in the city, to keep it in awe; the other two were commanded by his colleagues, and were led, one against the Æqui, and the other against the Sabines. The Roman soldiers had now adopted a method of punishing the generals whom they disliked, by suffering themselves to be vanquished in the field. They put it in practice upon this occasion, and shamefully abandoned their camp on the approach of the enemy. Never was the news of a victory more joyfully received at Rome than the tidings of this defeat: the generals, as always, were blamed for the treachery of their men: some demanded that they should be deposed; others that a dictator should lead the troops to conquest: among the rest Sicinius Dentatus, an old tribune, spoke his sentiments with his usual openness; and, treating the generals with contempt, showed the faults of their discipline in the camp and of their conduct in the field. Appius, in the mean time, was not remiss in observing the popular disposition. Dentatus, in particular, was marked out for vengeance, and, under pretence of doing him particular honor, was appointed legate, and put at the head of the supplies which were sent from Rome to the army. The office of legate was held sacred among the Romans, as in it were united the authority of a general with the reverence due to the priesthood. Dentatus proceeded to the camp with alacrity, where he was received with all the external marks of respect; but the generals soon found means of revenge. Appointed to head 100 men and examine a more commodious place for encampment, the soldiers, who were given as his attendants, were assassins, and led him out of the way into the bosom of a retired mountain. Dentatus, too late perceiving the treachery of the decemviri, was resolved to sell his life dearly; he therefore placed his back against a rock, and defended himself against those who pressed on him, killing no fewer than fifteen of the assailants, and wounding thirty. The assassins, terrified at his amazing bravery, now showered in their javelins upon him, all which he received on his shield; and the combat, though so unequal in numbers, was long managed with doubtful success, till at length his assailants, ascending the rock against which he stood, poured down stones on the brave old soldier from above, and crushed him to

death. The decemviri, pretending to join in the general sorrow for so brave a man, decreed him a funeral, with military honors: but the greatness of their apparent distress, compared with their known hatred, only rendered them still more detestable to the people.

A transaction still more atrocious inspired the citizens with a resolution to break all measures of obedience. Appius, who remained at Rome, sitting one day on his tribunal to dispense justice, saw a maiden of exquisite beauty passing to one of the public schools, attended by her nurse. Conceiving a violent passion for her, he resolved to obtain the gratification of his desires; and though he found she was the daughter of Virginius a centurion, then with the army in the field, and had been contracted to Icilius, formerly a tribune of the people, he resolved to break this match and espouse her himself. The laws of the Twelve tables, however, had forbidden the patricians to intermarry with the plebeians; and he could not infringe these. A yet more criminal course was therefore determined on. He engaged one Claudius, who had long been the minister of his pleasures, to assert that Virginius was his slave, and to refer the cause to his tribunal for decision. Claudius behaved according to his instructions; and, entering into the school where she was playing among her female companions, seized upon her as his property, and was only prevented from dragging her away by force by the people drawn together by her cries. At length, after the opposition was over, he led the weeping virgin to the tribunal of Appius, and there alleged his claim. He asserted that she was born in his house, of a female slave, who sold her to the wife of Virginius, who had been barren. That he had several credible evidences to prove the truth of what he said; but that, until they could come together, it was but reasonable the slave should be delivered into his custody. Appius seemed to be struck with the justice of his claim. He observed that, if the reputed father himself were present, he might indeed be willing to delay the delivery of the maiden for some time; but that it was not lawful for him, in the present case, to detain her from her master. He therefore adjudged her to Claudius, as his slave, to be kept by him till Virginius should be able to prove his paternity. This sentence was received with loud clamors and reproaches; the women, in particular, came round Virginia, as if willing to protect her from the judge; while Icilius, her lover, boldly opposed the decree, and obliged Claudius to take refuge under the tribunal of the decemviri. All things now threatened an open insurrection; when Appius thought proper to suspend his judgment till the arrival of Virginius, who was then about eleven miles from Rome. The day following was fixed for the trial: in the mean time Appius sent letters to the generals to confine Virginius, as his arrival in town might only serve to kindle sedition. These letters, however, were intercepted by the centurion's friends, and, pretending the death of a near relation, he obtained permission to leave the camp, and flew to Rome. The next day he appeared before the tribunal, to the astonishment of Appius, leading his weeping daughter by the hand, both being habited in

the deepest mourning. Claudius, the accuser, was also there, and began by making his demand. Virginius next spoke: he represented that his wife had many children; that she had been seen pregnant by numbers; that, if he had intentions of adopting a supposititious child, he would have fixed upon a boy rather than a girl; that it was notorious to all that his wife had herself suckled her own child; and that it was surprising such a claim should be now made, after fifteen years had elapsed. While the father thus spoke Virginius's persuasive innocence seemed to add weight to all his remonstrances. The people were entirely satisfied of the hardship of his case, till Appius interrupting him, under a pretence of being sufficiently instructed in the merits of the cause, finally adjudged her to Claudius, and ordered the lictors to carry her off. Virginius seemed to acquiesce in the sentence. He only mildly intreated Appius to be permitted to take a last farewell of one whom he had long considered as his child. With this the decemvir complied, when the father, with the most poignant anguish, taking his almost expiring daughter in his arms, for a while supported her head upon his breast, and wiped away her tears: happening to be near the shops that surrounded the forum, he now snatched up a knife that lay on the shambles, and buried the weapon in her breast; then holding it up, reeking with the blood of his daughter, 'Appius, he cried, 'thy this blood of innocence, I devote thy head to the infernal gods.' Thus saying, with the bloody knife in his hand, and threatening destruction to whomsoever should oppose him, he ran through the city, wildly calling upon the people to strike for freedom, and thence went to the camp, spreading a like flame. Followed by a number of his friends, he informed the soldiers of all that was done, holding the bloody knife in his hand, and asked their pardon, and that of the gods, for having committed so rash an action. The army, already predisposed, instantly with shouts declared their approbation of the deed; and, decamping, left their generals behind, to take their station once more upon mount Aventine. The other army, which had been to oppose the Sabines, came over in large parties to join them. Appius, in the mean time, did all he could to quell the disturbances of the city: but, finding the tumult incapable of control, at first attempted to find safety by flight; then encouraged by Oppius, one of his colleagues, he ventured to assemble the senate, and urged the punishment of all deserters. The senate, however, foresaw the dangers and miseries that threatened the state, in case of opposing the army; they therefore despatched messengers to them, offering to restore the former mode of government. To this proposal all the people joyfully assented, and the army gladly tendered their submission. Appius, and Oppius one of his colleagues, both died by their own hands in prison. The other eight decemvirs went into voluntary exile.

The tribunes now grew more turbulent: they proposed two laws; one to permit plebeians to intermarry with patricians, and the other to permit them to be admitted to the consulship. These proposals the senators received with indignation, and seemed resolved to undergo the

utmost extremities rather than enact them. However, finding this resistance only increase the public commotions, they at last consented to pass the law concerning intermarriages. But the people were thus appeased only for a short time; returning to their old custom of refusing to enlist upon the approach of an enemy, the consuls were forced to hold a private conference with the chief of the senate; where, after many debates, Claudius proposed to create six or eight governors in the room of consuls, whereof one-half at least should be patricians. This project was eagerly embraced by the people; yet, though many of the plebeians stood, the choice wholly fell upon the patrician candidates. These new magistrates were called military tribunes; they were at first but three, afterwards four, and at length six. They had the power and ensigns of consuls; yet, that power being divided among a number, each singly was of less authority. The first that were chosen only continued in office about three months, the augurs having found something amiss in the ceremonies of their election. Consuls once more, therefore, came into office; and, to lighten the weight of business which they were obliged to sustain, a new office was erected, namely, that of censors, to be chosen every fifth year. Their business was to take an estimate of the number and estates of the people, and to distribute them into their proper classes; to enquire into their lives and manners; to degrade senators for misconduct: to dismount knights; and to displace plebeians from their tribes into inferior ones, in case of misdemeanor. The two first censors were Papirius and Sempronius, both patricians; and from this order they continued to be elected for nearly 100 years. This new creation served to restore peace for some time; and the triumph gained over the Volscians by Geganius the consul added to the universal satisfaction. But some time after, a famine pressing hard upon the poor, the usual complaints against the rich were renewed; and these, as before, proving ineffectual, produced new seditions. The consuls were accused of neglect in not having laid in proper quantities of corn; they, however, disregarded the murmurs of the populace, content with exerting all their care in attempts to supply the pressing necessity: and appear to have done all that could be expected from active magistrates. Yet Spurius Mælius, a rich knight, who had bought up all the corn of Tuscany, outshone them in liberality. This demagogue, hoping to become powerful by the contention in the state, distributed corn in great quantities among the poor, till his house became the asylum of all such as wished to exchange a life of labor for one of lazy dependence. When he had thus gained a sufficient number of partizans, he procured large quantities of arms to be brought into his house, and formed a conspiracy, by which he was to obtain supreme command, while some of the tribunes, whom he had corrupted, were to act under him. Minucius discovered the plot, and, informing the senate, they resolved to create a dictator, who should quell the conspiracy, without appealing to the people. Cincinnatus, now eighty years old, was chosen once more to

rescue his country from impending danger. He began by summoning Mælius; who refused to obey. He next sent Ahala, the master of his horse, to compel his appearance; who, meeting him in the forum, and pressing him to follow to the dictator's tribunal, upon his refusal Ahala killed him on the spot. The dictator applauding his officer, now commanded the conspirator's goods to be sold, his house to be demolished, and his stores to be distributed among the people. But the tribunes were enraged at the death of Mælius; and, to punish the senate, at the next election, instead of consuls, insisted upon restoring their military tribunes. With this the senate were obliged to comply. The next year, however, the government returned to its ancient channel, and consuls were chosen.

The Veientes had at this period long been the rivals of Rome, and had ever taken the opportunity of its internal distresses to ravage its territories; they had even threatened its ambassadors sent to complain of these injuries with outrage. In war they had been extremely formidable, and had cut off almost all the Fabian family; who, to the number of 306 persons, had voluntarily undertaken to defend the frontiers against them. It was therefore determined that the city of Veii should be demolished; and the Roman army set down before it, prepared for a protracted resistance. The strength of the place may be inferred from the continuance of the siege, which lasted ten years. Various was the success, and many were the commanders: the besiegers' works were often destroyed, and many of their men cut off, until the undertaking seemed to threaten depopulation to Rome itself; so that a law was made for all the bachelors to marry the widows of the soldiers who were slain. To carry on this siege with greater vigor Furius Camillus was created dictator. Upon his appointment numbers of the people flocked to his standard, confident of success, and he at once prepared to mine the works of the enemy. Certain of the result, he sent to the senate, desiring that all who chose to share in the plunder of Veii should immediately repair to the army: and, entering the breach at the head of his men, the city was instantly filled with his legions. Thus, like a second Troy, was the city of Veii taken, after a ten years' siege, and with its spoils enriched the conquerors; while Camillus himself was decreed a triumph after the manner of the kings of Rome, having his chariot drawn by four milk-white horses. His usual good fortune attended Camillus in a new expedition against the Falisci; he routed their army, and besieged their capital Falerii, which threatened a long and vigorous resistance. Here a schoolmaster, who had the care of the children belonging to the principal men of the city, having decoyed them into the Roman camp, offered to put them into the hands of Camillus, as the surest means of inducing the citizens to surrender. But the general, struck with the treachery of a wretch whose duty it was to protect innocence, and not to betray it, immediately ordered him to be stripped, his hands tied behind him, and in that ignominious manner to be whipped into the town by his pupils. This generous behaviour in Camillus effected more than his arms;

the magistrates immediately submitted to the senate, leaving to Camillus the conditions of their surrender; who only fined them in a sum of money, and received them under the protection and the alliance of Rome.

The tribunes at home still, however, were full of accusations against Camillus. To their other charges they added that of his having concealed a part of the plunder of Veii, particularly two brazen gates, for his own use; and appointed a day on which he was to appear before the people. Camillus, finding the multitude exasperated, and detesting their ingratitude, resolved not to wait the ignominy of this trial; but, embracing his wife and children, prepared to depart from Rome. He had passed one of the gates when, turning his face to the capitol, and lifting up his hands to heaven, he entreated all the gods that his countrymen might one day be sensible of their injustice. He then passed forward to Ardea, where he afterwards learned that he had been fined 1500 asses. The Romans indeed soon had reason to repent their persecution of this general; for now a more formidable enemy than ever they had encountered threatened the republic: an inundation of Gauls, under their leader Brennus. One Cœditiuſ pretended to have heard a miraculous voice, saying, 'Go to the magistrates, and tell them that the Gauls draw near.' His warning was despised; but, when the event showed the truth of his prediction, Camillus erected a temple to the unknown Deity, and the Romans invented for him the name of Aius Locutius. Messengers arrived repeatedly with the news of the devastations of the enemy; but the Romans behaved as if an invasion had been impossible. At last envoys arrived at Rome, imploring assistance against an army of Gauls, which now besieged Clusium. Here Arunx, one of the chief citizens, having been guardian to a young noble, he fell in love with his guardian's wife; and, upon the first discovery of the intrigue, conveyed her away. Arunx endeavoured to obtain reparation for the injury; but the magistrates were bribed, and the injured guardian, to espouse the cause of this lover, applied to the Galli Senones to engage in this quarrel, acquainting them with the great plenty of Italy. Upon this the Senones resolved to follow him; and, a numerous army being formed, they passed the Alps, under the conduct of their Etrurian guide, and, leaving the Celtæ unmolested in Italy, fell upon Umbria, and possessed themselves of all the country from Ravenna to Picenum. They were about six years in settling themselves in their new acquisitions: at length Arunx brought the Senones before Clusium, his wife and her lover having shut themselves up in that city. The senate, therefore, sent an embassy of three young patricians of the Fabian family to bring about an accommodation: but these ambassadors, forgetting their character, put themselves at the head of the besieged in a sally, in which Q. Fabius, their chief, slew with his own hand one of the principal officers of the Gauls. Hereupon Brennus, calling the gods to witness the perfidiousness of the Romans, and immediately raising the siege, marched leisurely to Rome,

having sent a herald before him to demand that those ambassadors, who had so manifestly violated the law of nations, should be delivered up to him. The senate was now greatly perplexed between their regard for the laws and their affection for the Fabii. The wisest of them thought the demand to be but just: however, as it concerned one of great consequence and popularity, the conscript fathers referred the affair to the people, who by their curiæ were so far from condemning the three brothers, that, at the next election of military tribunes, they were chosen. Brennus, looking upon this promotion as a high affront, hastened to Rome. The six military tribunes, Q. Fabius Cæso Fabius, Caius Fabius, Q. Sulpicius Servilius, and Sextus Cornelius, marched to meet him at the head of 40,000 men, but went out either sacrificing to the gods or consulting the auspices: ceremonies essential among a people that drew their courage and confidence from these signs. The Gauls were 70,000 strong. The two armies met near the river Allia, a distance of sixty furlongs from Rome; when the Gauls extended their wings so far as to make the centre very thin. Their best troops, to the number of 24,000 men, they posted between the city and the adjoining hills; the rest on the hills. The first the Gauls attacked the latter, who being put into confusion, the forces in the plain were struck with such terror that they fled without drawing a sword: and most of the soldiers were drowned as they endeavoured to cross the Tiber; many fell in the pursuit by the sword of the conquerors: and some got to Rome, which they filled with terror and consternation. The day after the battle, Brennus marched his troops into the neighbourhood of the capitol, encamped on the banks of the Anio. His scouts brought him word that the gates of the city were open, and not a Roman to be seen on the ramparts. He advanced slowly, fearing an ambuscade, which gave the Romans an opportunity to throw into the capitol the men who were fit to bear arms, with abundant provisions. They had not sufficient men to defend the city: the old men, women, and children, therefore, fled to the neighbouring towns. At length Brennus, having spent several days in taking various precautions, entered the city on the fourth day after the battle. The gates being open, the walls without defence, and the city without inhabitants. Rome appeared like a mere desert; but he could not believe that all the Romans were lodged in the capitol, or that so numerous a people should abandon the place of their nativity. On the other side he could no where see any armed men, but the walls of the citadel. Having first sent all the avenues to the capitol with his own guards, he at last gave the rest of his army leave to disperse themselves over the city, to plunder it. Brennus himself advanced into the forum with the troops under his command in order; and was there struck with admiration at the unexpected sight of the venerable men who had devoted themselves to death, and

to the Roman superstition, for the salvation of their country. They were a portion of the priests and the most ancient of the senators who had been honored with consular dignity, or who had been decreed triumphs. Their magnificent habits, the majesty of their countenances, the silence they kept, their modesty and constancy at the approach of his troops, made him take them for so many deities. The Gauls for a great while kept at an awful distance from them. At length a soldier, bolder than the rest, having out of curiosity touched the beard of M. Papirius, the old man, not being used to such familiarity, gave him a blow on the head with his ivory staff, and the soldier in revenge immediately killed him. The rest of the Gauls, following his example, slaughtered the whole of the companions of Papirius without mercy. After this the enemy set no bounds to their rage; dragging such of the Romans forth as had concealed themselves in their houses, and putting them to the sword in the streets without distinction of age or sex. Brennus then invested the capitol; but, being repulsed with great loss, to be revenged on the Romans he resolved to lay the city in ashes. Accordingly, by his command, the soldiers set fire to the houses, destroyed the temples and public edifices, and razed the walls to the ground. Thus was Rome in fact demolished: nothing was to be seen on its site but a few hills covered with ruins, and a wide waste, in which the Gauls who invested the capitol were encamped. Brennus, finding he should never be able to take a place which nature had so well fortified, except by famine, turned the siege into a blockade, and sent out parties to pillage the fields, and raise contributions. One of these appeared before Ardea, where Camillus had now spent two years in private life. Notwithstanding the affront he had received at Rome, the love he bore his country was not diminished, and, the senate of Ardea being met to deliberate on the measures to be taken with relation to the Gauls, Camillus desired to be admitted into the council. Here he prevailed upon the Ardeates to arm their youth in their own defence, and refuse the Gauls admittance into their city, and finally marched out in a very dark night, surprised the Gauls drowned in wine, and made a dreadful slaughter of them. Those who escaped under shelter of the night fell next into the hands of the peasants, by whom they were massacred without mercy. This defeat revived the courage of the Romans, especially of those who had retired to Veii. There was not one of them who did not condemn the exile of Camillus, and they now resolved to choose him for their leader. Accordingly, they sent ambassadors beseeching him to take into his protection the fugitive Romans, and the wrecks of the defeat at Allia. But Camillus would not accept of the command of the troops till the people assembled by curiæ had legally conferred it upon him; and to communicate with them was difficult, the capitol being invested on all sides. But Pontius Cominius, a man of mean birth, but bold, and very ambitious, undertook it. He put on a light habit, covered with cork, and, throwing himself into the Tiber above Rome in the beginning of the night, suf-

fered himself to be carried down the stream. At length he came to the foot of the capitol, and, landing at a steep place where the Gauls had not posted sentinels, mounted with great difficulty to the rampart of the citadel; and, having made himself known to the guards, was admitted into the place, and conducted to the magistrates. The remnant of the senate being immediately assembled, Pontius gave them an account of Camillus's victory; and in the name of all the Romans at Veii demanded that great captain for their general. The curiæ being called together, the act of condemnation passed on Camillus was now abrogated; he was unanimously named dictator, and Pontius, being despatched with the decree, reached the army in safety. Thus was Camillus, from banishment, raised at once to be sovereign magistrate of his country. His promotion was no sooner known, but soldiers flocked from all parts to his camp; insomuch that he soon saw himself at the head of above 40,000 men, partly Romans and partly allies, who all thought themselves invincible. In the interim, while taking measures to raise the blockade of the citadel, some Gauls perceived on the side of the hill the print of Pontius's hands and feet. They observed likewise that the moss on the rocks was in several places torn up. From these marks they concluded that somebody had lately gone up to and returned from the capitol, and made their report to Brennus of what they had observed; when he immediately conceived the design, which he imparted to none, of surprising the place by the same way that it had been ascended. With this view he chose out of the army such soldiers as had dwelt in mountainous countries, and been accustomed from their youth to climb precipices. These he ordered, after he had well examined the nature of the place, to ascend in the night the way that was marked out for them, climbing two abreast, that one might support the other in getting up. By these means with much difficulty they advanced from rock to rock, till they arrived at the foot of the wall; and proceeded with such silence that they were not discovered or heard, either by the sentinels who were upon guard in the citadel, or even by their dogs. But a flock of geese kept in a court of the capitol in honor of Juno, and near her temple, had been spared from religious feeling, and were alarmed at their first approach; so that, running up and down, they awoke, with their cackling, Manlius, a soldier, who some years before had been consul. He sounded an alarm, and was the first who mounted the rampart, where he found two Gauls. One of these aimed a blow at him with his battle-ax; but Manlius in return cut off his right hand, and pushed his companion with his buckler headlong from the top of the rock. In his fall he drew several others down; and in the meantime the Romans, crowding to the place, pressed upon the approaching enemy, and tumbled them over one another. As the nature of the ground would not suffer them to make a regular retreat, or even to fly, most of them, to avoid the swords of the enemy, threw themselves down the precipice, so that very few got safe back. Manlius was finally rewarded, and the captain of the Roman guard thrown

down the precipice. The Romans extended their punishments and rewards even to the brutes. Geese were ever after had in honor at Rome, and a flock of them always kept at the expense of the public. A golden image of the bird was erected, and a goose every year carried in triumph upon a soft litter finely adorned; whilst dogs were held in abhorrence, and the Romans every year impaled one of them on a branch of elder. The blockade of the capitol had already lasted seven months; so that the want of provisions was very severely felt both by the besieged and besiegers. Camillus, since his nomination to the dictatorship, being master of the country, had posted strong guards on all the roads; so that Brennus, who besieged the capitol, was himself besieged, and suffered the same inconveniences which he inflicted on the Romans. Besides, a plague raged in his camp, which was placed in the midst of the ruins of the demolished city; and so great a number of them died in one quarter that it was afterwards called *Busta Gallica*, or the place where the dead bodies of the Gauls were burnt. In the mean time the capitol was reduced to the last extremity, and ignorant of the steps Camillus was taking to relieve them. That great general, on the other hand, not knowing the extreme want endured in the capitol, only waited for a favorable opportunity to fall upon the enemy; but, in the mean time, suffered them to pine away in their infected camp. The senate, at last, not knowing what was become of Camillus, resolved to enter upon a negotiation, and empowered Sulpitius, one of the military tribunes, to treat with the Gauls; who made no great difficulty in coming to terms. In a conference, therefore, between Brennus and Sulpitius, an agreement was made; that the Romans were to pay to the Gauls 1000 lbs. of gold (about £45,000 sterling), and the latter to raise the siege of the capitol, and quit all the Roman territories. On the day appointed, Sulpitius brought the sum agreed on, and Brennus the scales and weights. Historians state that the weights of the Gauls were false, and their scales untrue; which Sulpitius complaining of, Brennus, instead of redressing the injustice, threw his sword and belt into the scale where the weights were; and, when the tribune asked him the meaning of so extraordinary a behaviour, the only answer he gave was, *Væ Victis!* 'Woe to the conquered!' Sulpitius was so stung with this haughty answer that he was for carrying the gold back into the capitol, and sustaining the siege to the last extremity; but other Romans thought it advisable to put up with the affront. During these disputes of the deputies among themselves and with the Gauls, Camillus advanced with his army to the very gates of Rome; and, being there informed of what had taken place, he commanded the main body to follow him, and, arriving at the place of parley, exclaimed 'Carry back your gold into the capitol; and you, Gauls, retire with your scales and weights. Rome must not be redeemed with gold, but with steel.' Brennus replied, 'that he contravened a treaty which was concluded and confirmed with mutual oaths.' 'Be it so,' answered Camillus, 'yet it is of no force having been made by an inferior magistrate,

without the privity or consent of the dictator. I, who am vested with the supreme authority over the Romans, declare the contract void.' At these words, both sides drawing their swords, a confused scuffle ensued, in which the Gauls, after an inconsiderable loss, were forced to retire to their camp; which they abandoned in the night, and, having marched eight miles, encamped on the Gabinian way. Camillus pursued them as soon as it was day, and gave them a total overthrow, the Gauls, according to Livy, making but a faint resistance. It was not, says that author, so much a battle as a slaughter. Many of the Gauls were slain in the action, more in the pursuit; but the greater number were cut off, as they wandered up and down in the fields, by the inhabitants of the neighbouring villages. In short, there was not one single Gaul left to carry to his countrymen the news of this catastrophe. The camp of the barbarians was plundered; and Camillus, loaded with spoils, returned in triumph to the city, the soldiers styling him another Romulus, the Father of his country, and the Second Founder of Rome.

As the houses of Rome were now all razed, the tribunes of the people renewed, with more warmth than ever, an old project which had occasioned great disputes. They had formerly proposed a law for dividing the senate and government between the cities of Veii and Rome. This idea was revived; nay, most of the tribunes were for entirely abandoning their old ruined city, and making Veii the sole seat of the empire. But the senate took the part of Camillus, and, being desirous to see Rome rebuilt, continued him, contrary to custom, a full year in the office of dictator; during which time he made it his whole business to suppress the inclination of the people to remove to Veii. Having assembled the curiæ, he prevailed on them to lay aside all thoughts of leaving Rome; and, when the dictator reported the resolution of the people to the senate, while L. Lucretius, who was to give the first opinion, was beginning to speak, it happened that a centurion, then marching by the senate-house, cried out aloud, 'Plant your colors, ensign; this is the best place to stay in.' These words were considered as dictated by the gods; and Lucretius, taking occasion from them to urge the necessity of staying at Rome: 'A happy omen!' cried he, 'I adore the gods who gave it.' The whole senate applauded his words; and a decree was passed without opposition for rebuilding the city. Though the tribunes were defeated by Camillus in this point, they resolved to exercise their authority against another patrician, who had indeed deserved punishment. This was Q. Fabius, who had violated the law of nations, and thereby provoked the Gauls, and occasioned the burning of Rome. His crime being notorious, he killed himself to avoid punishment. On the other hand, the republic gave a house situated on the capitol to M. Manlius, as a monument of his valor, and of the gratitude of his fellow-citizens. Camillus closed this year by laying down his dictatorship: whereupon an interregnum ensued, during which he governed the state alternately with P. Cornelius Scipio; and it fell to his lot to preside at the election of

new magistrates when L. Valerius Poplicola, L. Virginius Tricostus, P. Cornelius Cossus, A. Manlius Capitolinus, L. Æmilius Mamercinus, and L. Posthumus Albinus, were chosen. The first care of these magistrates was to collect all the ancient monuments of the religion and civil laws of Rome which could be found among the ruins of the demolished city. The laws of the twelve tables, and some of the laws of the kings, had been written on brass, and fixed up in the forum; and the treaties made with several nations had been engraved on pillars erected in the temples. Pains were therefore taken to gather up the ruins of these precious monuments; and what could not be found was supplied by memory. The pontifices, on their part, took care to re-establish the religious ceremonies, and made also a list of lucky and unlucky days. And now the governors of the republic applied themselves wholly to rebuild the city.

But Rome was scarcely restored when her citizens were alarmed by the news that all her neighbours were combining her destruction. The Æqui, Volsci, Etrurians, and even her old friends the Latins and Hernici, entered into an alliance against her. The republic, under this terror, nominated Camillus dictator a third time. He divided his new levies into three bodies. The first, under the command of A. Manlius, he ordered to encamp under the walls of Rome; the second he sent into the neighbourhood of Veii; and marched himself at the head of the third, to relieve the tribunes, who were closely besieged in their camp by the forces of the Volsci and Latins. Finding the enemy encamped near Lanuvium, on the declivity of the hill Marcius, he posted himself behind it, and, by lighting fires, gave his countrymen notice of their arrival. The Volsci and Latins, when they understood that Camillus was at the head of an army newly arrived, were so terrified that they shut themselves up in their camp, which they fortified with trees cut down in haste. The dictator observing that this barrier was of green wood, and that every morning there arose a great wind, which blew fall upon the enemy's camp, formed the design of taking it by fire. With this view he ordered one part of his army to go by break of day with fire-brands to the windward side of the camp, and the other to make a brisk attack on the opposite side. By these means the enemy were entirely defeated, and their camp taken. Camillus then commanded his men to extinguish the flames, and to save the booty, with which he rewarded his army. Then leaving his son in the camp to guard the prisoners, and entering the country of the Æqui, he made himself master of their capital, Bola. Thence he marched against the Volsci; whom he entirely reduced, after they had waged war with the Romans for the space of 107 years. He next penetrated into Etruria, to relieve Sutrinum, a town in alliance with Rome. But, notwithstanding all the expedition Camillus could use, he did not reach the place before it had capitulated. The Sutrini being greatly distressed for want of provisions, and exhausted with labor, had surrendered to the Etrurians, who had granted them nothing but their lives

and clothes. In this destitute condition they had left their own country, and were going in search of new habitations, when they met Camillus. The unfortunate multitude no sooner saw the Romans than they threw themselves at the dictator's feet, who desired them to take a little rest, and refresh themselves, adding that he would soon dry up their tears, and transfer their sorrows to their enemies. The latter did not dream that the dictator could come so speedily from such a distance; and therefore were wholly employed in plundering the houses, or feasting on the provisions they found in Sutrium. Many of them were, therefore, put to the sword, while an incredible number were made prisoners; and the city was restored to its ancient inhabitants. And now, after these glorious exploits, which were finished in so short a time, Camillus entered Rome in triumph a third time; resigned his dictatorship, and the public chose six new military tribunes, Q. Quinctius, Q. Servius, L. Julius, L. Aquilius, L. Lucretius, and Ser. Sulpitius. During their administration the country of the Æqui was laid waste, in order to put it out of their power to revolt anew; and the two cities of Cortuosa and Contenebra, in the lucumony of the Tarquinienses, were taken from the Etrurians. At this time it was thought proper to repair the capitol, and add new works to that part of the hill which the Gauls had endeavoured to scale. These works were esteemed very beautiful, as Livy informs us, even in the time of Augustus. And now, Rome being reinstated in her former flourishing condition, the tribunes, who had been for some time quiet, began to renew their seditious harangues, and revive the old quarrel about the division of the conquered lands. As for the military tribunes, they owned that their election had been defective; and voluntarily laid down their office. So that, after a short interregnum, during which M. Manlius, Ser. Sulpitius, and L. Valerius Potitius, governed the republic, six new military tribunes, L. Papirius, C. Sergius, L. Æmilius, L. Menenius, L. Valerius, and C. Cornelius, were chosen for the ensuing year, which was spent in works of peace. A temple, which had been vowed to Mars during the war, was built and consecrated by T. Quinctius. As there had hitherto been but few Roman tribes beyond the Tiber which had a right of suffrage in the comitia, four new ones were added, under the name of the Stellatina, Tramontina, Sabatina, and Arniensis; so that the tribunes were now in all twenty-five, which enjoyed the same rights and privileges.

The expectation of an approaching war induced the centuries to choose Camillus one of the military tribunes for the next year. His colleagues were Ser. Cornelius, Q. Servilius, L. Quinctius, L. Horatius, and P. Valerius. As all these were moderate and considerate men, they agreed to invest Camillus with the sole management of affairs in time of war; and in full senate transferred their power into his hands. It had already been determined in the senate to turn the arms of the republic against the Etrurians; but, upon intelligence being received that the Antiates had entered the Pomptin territory, and obliged the



Romans who had taken possession of it to retire, it was thought necessary to humble them first. The Antiates had joined the Latins and Hernici near Satricum; so that the Romans, being appalled at their prodigious numbers, showed themselves backward to engage; which Camillus perceiving, he mounted his horse, and riding through all the ranks of the army, encouraged them by a suitable harangue; after which he dismounted, took the next standard bearer by the hand, and led him towards the enemy, crying out, Soldiers, advance. The soldiery now fell on the enemy with incredible fury. Camillus, to increase their eagerness, commanded a standard to be thrown into the middle of the enemy's battalions; which made those who were fighting in the first ranks, exert all their resolution to recover it. The Antiates gave way, and were entirely defeated: the Latins and Hernici separated from the Volsci, and returned home: while the Volsci, seeing themselves abandoned by their allies, took refuge in the city of Satricum; which Camillus immediately invested, and took by assault, when the Volsci surrendered at discretion. He then left his army under the command of Valerius; and returned to Rome to solicit the consent of the senate, and make the necessary preparations for the siege of Antium. But, while he was proposing this affair, deputies arrived from Nepes and Sutrium, cities in alliance with Rome, demanding succors against the Etrurians, who threatened to besiege them. Hereupon the expedition against Antium was laid aside, and Camillus commanded to hasten to the relief of the allied cities, with the troops which Servilius had at Rome. Camillus immediately set out for the new war; and, upon his arrival before Sutrium, found it not only besieged but almost taken, the Etrurians having made themselves masters of some of the gates, and all the avenues of the city. But the inhabitants hearing that Camillus was come, recovered their courage, and, by barricadoes in the streets, prevented the enemy from making themselves masters of the whole. Camillus, dividing his army into two bodies, ordered Valerius to march round the walls, while he charged the Etrurians in the rear; on which the latter betook themselves to flight through a gate which was not invested. Camillus's troops made a dreadful slaughter of them within the city, while Valerius made equal havoc without the walls. Camillus hastened to the relief of Nepes, which had submitted to the Etrurians. He took it by assault, put all the Etrurian soldiers to the sword, and condemned the authors of the revolt to die by the axes of the lictors. Thus ended Camillus's military tribuneship, in which he acquired no less reputation than he had done in the most glorious of his dictatorships.

In the following magistracy of six military tribunes, a dangerous sedition is said to have taken place through the ambition of Marcus Manlius, who had saved the capitol from the Gauls. He envied Camillus, magnified his own exploits beyond those of the dictator, concerted measures with the tribunes, and strove to gain the affections of the multitude by advocating the Agrarian law, and that for the relief of insolvent

debtors, of whom there was now a great number. The senate, alarmed at this opposition, created A. Cornelius Cossus dictator, for which the war with the Volsci afforded them a fair pretence. Manlius still continued to inflame the people against the patricians. Besides the most unbounded personal generosity, he held assemblies at his own house (in the citadel) where he slandered the senators, affirming that they appropriated to their own use all the gold which was to have been paid to the Gauls. Upon this he was committed to prison; but the people made such disturbance that the senate released him. At last he was publicly accused of aspiring to be king; but the Romans, grateful for his having delivered the capitol, could not condemn him. The military tribunes, however, having appointed the assembly to be held without the city, obtained their wish; and Manlius was thrown headlong from the capitol; the people, who lamented his fate, imputing a plague, which broke out soon after, to the anger of the gods on that account.

The Romans, having now triumphed over the Sabines, the Etrurians, the Latins, the Hernici, the Equi, and the Volscians, began to look for greater conquests. They accordingly turned their arms against the Samnites, a people about 100 miles east from the city, descended from the Sabines, and inhabiting a large tract of southern Italy. Valerius Corvus and Cornelius were consuls. The first was one of the greatest commanders of his time, and surnamed Corvus, from the circumstance of being singularly assisted by a crow in a single combat, in which he fought and killed a Gaul of a gigantic stature. To his colleague's care it was consigned to lead an army to Samnium, the enemy's capital, while Corvus was sent to relieve Capua, the capital of the Campanians. The Samnites were the bravest men the Romans had ever yet encountered, and the contention between the two nations was managed on both sides with the most determined resolution. But the fortune of Rome prevailed; and the Samnites at length fled. The other consul, having led his army into a defile, was in danger of being cut off, had not Decius, a tribune, possessed himself of a hill which commanded the enemy; so that the Samnites, being attacked on both sides, were defeated with great slaughter, no fewer than 30,000 of them being left dead upon the field. Some time after this victory, the soldiers who were stationed at Capua mutinying, forced Quintus, an old and eminent soldier, to be their leader; and came within eight miles of Rome. The senate immediately created Valerius Corvus dictator, and sent him with another detachment to oppose them. The two armies were now drawn up against each other, while fathers and sons beheld themselves prepared to engage in opposite causes; but Corvus, knowing his influence among the soldiers, instead of going forward to meet the mutineers in a hostile manner, went with the most cordial friendship to embrace and expostulate with his old acquaintances. His conduct had the desired effect. Quintus only desired to have their defection forgiven. A war between the Romans and Latins followed soon after; and as their

habits, arms, and language, were the same, the most exact discipline was necessary to prevent confusion in the engagement. Orders, therefore, were issued by the consul Manlius, that no soldier should leave his ranks under pain of death. With these injunctions, both armies were drawn out in array, when Metius, the general of the enemy's cavalry, pushed forward and challenged any knight in the Roman army to single combat. For some time there was a general pause, no soldier offering to disobey his orders, till Titus Manlius, the consul's son, burning with shame to see the whole body of the Romans intimidated, boldly sallied out against his adversary. Manlius killed his adversary; and, despoiling him of his armor, returned in triumph to his father's tent, where he was giving orders relative to the engagement. Doubtful of the reception he should find, he came, with hesitation, to lay the enemy's spoils at his feet, and insinuated that what he did was entirely from a spirit of hereditary virtue. But his father, turning away, ordered him to be led forth before the army, and there to have his head struck off on account of his disobeying orders. The whole army was struck with horror at this unnatural mandate; but when they saw their young champion's head struck off, and his blood streaming upon the ground, they could no longer contain their execrations. His dead body, adorned with the spoils of the vanquished enemy, was buried with all the pomp of military greatness. Mean time the battle joined with mutual fury; and, as the two armies had often fought under the same leaders, they combated with all the animosity of a civil war. The Latins chiefly depended on their bodily strength; the Romans on their invincible courage. Forces so nearly matched seemed only to require the protection of their deities to turn the scale of victory; and the augurs had foretold that, whatever part of the Roman army should be distressed, the commander of that part should devote himself for his country. Manlius commanded the right wing, and Decius led on the left. Both sides fought for some time with doubtful success, but at last the left wing of the Roman army began to give ground. Decius having resolved to devote himself for his country, and to offer his own life to save his army, after the usual superstitions, mounting on horseback, drove furiously into the midst of the enemy, carrying terror and consternation wherever he came. He fell covered with wounds. The Roman army considering this as an assurance of success, and the superstition of the Latins being equally influenced by his resolution, a total rout ensued, and scarcely a fourth part of the enemy survived the defeat. This was the last battle that the Latins had with the Romans; they were forced to beg a peace upon hard conditions; and two years after, their strongest city, Pædum, being taken, they were brought under final submission to the Roman power.

About this time the Romans sustained a signal disgrace in their contests with the Samnites. The senate having denied that nation peace, Pontius their general resolved to gain by stratagem what he had frequently lost by force. Leading his army into a defile called Claudium, and taking possession of all its outlets, he sent

ten of his soldiers, habited like shepherds, to throw themselves in the way the Romans were to march. The consul met them, and demanded the route the Samnite army had taken; with seeming indifference they replied, that they were gone to Luceria, in Apulia, and were then besieging it. The Roman general marched directly by the shortest road, through the defiles, and was not undeceived till he saw his army surrounded. Pontius, thus having them entirely in his power, first obliged the Romans to pass under the yoke, stripped of all but their garments; he then stipulated that they should wholly quit the territories of the Samnites, and that they should continue to live upon terms of former confederacy. The Romans were constrained to submit to this treaty, and marched into Capua disarmed and half naked. But after this the power of the Samnites declined every day, while that of the Romans continually increased. Under Papirius Cursor, at different times consul and dictator, repeated triumphs were granted. Fabius Maximus also had his share in conquering them; Decius, the son of Decius who devoted himself, followed the example of his father. See DECIVS. The success of the Romans against the Samnites alarmed all Italy. The Tarentines, who had long plotted against the republic, now declared themselves; and invited into Italy Pyrrhus king of Epirus. The offer was readily accepted by that ambitious monarch. Their ambassadors carried magnificent presents, and told him that they only wanted a general of fame and experience; and that they could furnish 20,000 horse and 350,000 foot. As soon as the news of this deputation were brought to the Roman camp, Æmilius, who had hitherto made war on the Tarentines but gently, in hopes of adjusting matters by negotiation, began to commit all sorts of hostilities. He took cities, stormed castles, and laid the whole country waste, burning and destroying all before him. The Tarentines brought their army into the field, but Æmilius obliged them to take refuge within their walls. However, he used the prisoners with great moderation, and even sent them back without ransom. These highly extolled the generosity of the consul, many of the inhabitants were brought over to the Roman party, and they all began to repent of their having sent for Pyrrhus. But, in the mean time, the Tarentine ambassadors arriving in Epirus, pursuant to the powers they had received, made an absolute treaty with the king; who sent before him the famous Cyneas, with 3000 men, to take possession of the citadel of Tarentum. This minister deposed Agis, whom the Tarentines had chosen to be their governor. He likewise prevailed upon the Tarentines to deliver up the citadel into his hands; and sent messengers to Pyrrhus, pressing him to hasten his departure. Mean time, Æmilius resolved to quarter his troops in Apulia, near the territory of Tarentum. But being obliged to pass through defiles, with the sea on one side and hills on the other, he was attacked by the Tarentines and Epirots from barks fraught with balistæ, and from archers and slingers on the hills. Hereupon Æmilius placed the Tarentine prisoners between him and

the enemy; which the Tarentines perceiving, soon left off, so that the Romans took up their winter quarters in Apulia. The next year Æmilius was continued in command with the title of proconsul; and was ordered to make war upon the Salentines, who had declared for the Tarentines. The Romans now enlisted the proletarii, who were the meanest of the people, and had never before been suffered to bear arms. In the mean time Pyrrhus arrived at Tarentum, after having narrowly escaped shipwreck. The Tarentines, who were entirely devoted to their pleasures, expected that he should take all the fatigues of the war on himself, and expose only his Epirots to danger. But, his ships arriving one after another with his troops, he began to reform the disorders that prevailed. He shut up their theatre, public gardens, porticoes, and places of exercises, and prohibited all masquerades, plays, &c. They were utter strangers to military exercise; but Pyrrhus, having caused a register to be made of all the young men fit for war, picked out the strongest, and incorporated them among his own troops, exercising them daily for several hours. And because many, who had not been accustomed to such severity, left their native country, Pyrrhus, by a public proclamation, declared all such capitally guilty. In the mean time P. Valerius Lævinus, the Roman consul, entering the country of the Lucanians, who were in alliance with the Tarentines, committed great ravages there: and, having taken and fortified one of their castles, waited in that neighbourhood for Pyrrhus. Pyrrhus therefore took the field with his Epirots, some recruits of Tarentum, and other Italians; and marched towards those parts where Lævinus was waiting for him. The Romans were encamped on the other side of the river Siris; and Pyrrhus, appearing on the opposite bank, wished to reconnoitre the enemy's camp, and see what appearance they made. He crossed the river, attended by Megacles, and having observed the consul's intrenchments, the manner in which he had posted his advanced guards, and the good order of his camp, he was greatly surprised. On his return he changed his resolution of attacking them; and waited for the arrival of the confederates. In the mean time he posted strong guards along the river, and sent out scouts to watch the motions of the consul. Some of these being taken by the Romans, the consul led them through his camp, and, having showed them to his army, sent them back to the king, telling them that he had many other troops to show them in due time. Lævinus, being determined to draw the enemy to a battle before Pyrrhus received the reinforcements he expected, marched to the banks of the Siris; and there, drawing up his infantry in battalia, ordered the cavalry to file off, and march a great way about, to find a passage at some place not defended by the enemy. Accordingly they passed the river without being observed; and, falling upon the guards which Pyrrhus had posted on the banks over against the consular army, gave the infantry an opportunity of crossing the river on bridges which Lævinus had prepared. Before they got over Pyrrhus, hastening from his camp,

hoped to cut the Roman army in pieces while passing the river; but the cavalry covering the infantry, and standing between them and the Epirots, gave them time to form themselves. On the other hand Pyrrhus drew up his men as fast as they came from the camp, and performed such deeds of valor that the Romans found him worthy of the great reputation he had acquired. As the cavalry alone had hitherto engaged, Pyrrhus, who confided most in his infantry, hastened back to the camp, to bring them to the charge; and, having changed habits with Megacles, led his phalanx against the Roman legions with incredible fury. Lævinus sustained the shock with great resolution, so that the victory was for many hours warmly disputed. Both parties several times gave way, but rallied again, and were brought back to the charge by their commanders. Megacles, in the attire of Pyrrhus, was in all places, and well supported the character he had assumed. But his disguise at last proved fatal to him: for a Roman knight, named Dexter, taking him for the king, followed him wherever he went; and at last killed him, stripped him of his armour, and carried it in triumph to the consul, who, by showing to the Epirots the spoils of their king, so terrified them that they began to give way. But Pyrrhus, appearing in the first files of his phalanx, and riding through all the lines, undeceived his men, and inspired them with new courage. The advantage seemed to be equal on both sides, when Lævinus ordered his cavalry to advance; which Pyrrhus observing drew up twenty elephants in the front of his army, with towers on their backs full of bowmen. The sight of these dreadful animals chilled the bravery of the Romans, who had never before seen any. However they still advanced, till their horses, unable to bear the smell of them, and frightened at the strange noise they made, threw their riders, or carried them on full speed. In the mean time the archers, discharging showers of darts from the towers, killed many of the Romans, while others were trod to death by the elephants. Notwithstanding the disorder of the cavalry, the legionaries still kept their ranks, till Pyrrhus attacked them at the head of the Thessalian horse. The onset was so furious that they were forced to retire in disorder. But an elephant, which had been wounded, having caused a great disorder in Pyrrhus's army, this accident favored the retreat of the Romans, and gave them time to repossess the river, and take refuge in Apulia. Pyrrhus remained master of the field, and had the pleasure to see the Romans fly before him: but the victory cost him dear, a great number of his best officers and soldiers having been slain in the battle. His first care after the action was to bury the dead, and herein he made no distinction between the Romans and his Epirots. Pyrrhus next broke into the countries in alliance with the Romans, plundered the lands of the republic, and made incursions even into the neighbourhood of Rome. Many cities opened their gates to him, and he soon made himself master of the greatest part of Campania. While in that fruitful province he was joined by the Samnites, Lucanians, and Messapians, whom he had long expected. He then marched to lay

siege to Capua; but Lævinus, having already received a reinforcement of two legions, threw some troops into the city; which obliged Pyrrhus to drop his design, and, leaving Capua, to march to Naples. Lævinus followed him, harassing his troops on their march; and at length, by keeping his army in the neighbourhood, forced him to give over all thoughts of attacking that city. The king then took his route towards Rome by the Latin way, surprised Fregellæ, and, marching through the country of the Hernici, sat down before Præneste. There, from the top of a hill, he saw Rome. But he was soon forced to retire by the other consul T. Coruncanius, who, having reduced Etruria, was just returned with his victorious army to Rome. He therefore raised the siege of Præneste, and hastened back into Campania; where, to his surprise, he found Lævinus with a more numerous army than that which he had defeated on the banks of the Siris. The consul went to meet him, to try the fate of another battle; but Pyrrhus, pretending that the auguries were not favorable, retired to Tarentum, and put an end to the campaign. To this city the Romans sent him an embassy, consisting of Cornelius Dolabella, who had conquered the Senones, Fabricius, and Æmilius Pappus, to demand a surrender of the prisoners, either by way of exchange, or at a proper ransom; for Pyrrhus had taken 1800 prisoners, most of them Roman knights and men of distinction. Pyrrhus was disappointed when he found that they did not come with proposals of peace, of which he was very desirous, but he treated them with magnificence. He released 200 of the prisoners without ransom, and suffered the rest, on their parole, to return to Rome to celebrate the Saturnalia. Having thus gained the good will of the ambassadors, he sent Cyneas to Rome with proposals of peace on these terms:—1. That the Tarentines should be included in the treaty. 2. That the Greek cities in Italy should enjoy their laws and liberties. 3. That the republic should restore to the Samnites, Lucanians, and Bruttians, all the places taken from them. By the eloquence of the ambassadors, together with well applied bribes, he nearly effected his errand; but Appius Claudius, blind as he was, came down to the senate, and his oratorical influence had the effect to determine that Rome would enter into no terms with Pyrrhus while he remained in Italy. This resolution they followed up by despatching the consuls P. Sulpicius Saverrio, and P. Decius Mus, into Apulia, where they found Pyrrhus encamped near Asculum. A battle ensued, in which Decius was slain, and Pyrrhus wounded and defeated, with the loss of many of his troops. Sulpicius appeared in the field next day; but, finding the Epirots had withdrawn to Tarentum, he put his troops into winter quarters in Apulia. Both armies, early in the spring, took the field anew. The Romans were commanded this year by the consuls C. Fabricius and Q. Æmilius Pappus; who no sooner arrived in Apulia than they led their troops into the territory of Tarentum. Pyrrhus, who had received considerable reinforcements from Epirus, met them near the frontiers, and encamped at a small distance. While the

consuls were waiting for a favorable opportunity, a messenger from Nicias, the king's physician, delivered a letter to Fabricius; wherein the traitor offered to take off his master by poison for a suitable reward. The virtuous Roman immediately wrote to Pyrrhus, warning him, without discovering the criminal, to take care of himself, and to be upon his guard against the treacherous designs of those about him. Pyrrhus, out of gratitude, released immediately, without ransom, all the prisoners he had taken. But the Romans, disdaining to accept a recompense for not committing the blackest treachery, sent to Pyrrhus an equal number of Samnite and Tarentine prisoners. As the king of Epirus grew every day more weary of the war, he sent Cyneas again to Rome, to try if he could prevail upon the senate to harken to an accommodation upon terms consistent with honor, but in vain. Meantime ambassadors arrived at his camp from the Syracusians, Agrigentines, and Leontines, imploring his assistance to drive out the Carthaginians, who threatened their states with utter destruction. Pyrrhus, who wanted only some pretence to leave Italy, laid hold of this; and, appointing Milo governor of Tarentum, with a strong garrison, he set sail for Sicily with 30,000 foot, and 25,000 horse, on board a fleet of 200 ships. Here he was at first attended with great success; but the Sicilians, disgusted at the enormous extortions of his ministers, had submitted partly to the Carthaginians, and partly to the Mamertines. When Carthage heard of this change, new troops were raised all over Africa, and a numerous army sent into Sicily to recover the cities which Pyrrhus had taken. As the Sicilians daily deserted from him, he was not in a condition, with his Epirots alone, to withstand so powerful an enemy; and therefore, when deputies came to him from the Tarentines, Samnites, Bruttians, and Lucanians, representing to him that, without his assistance, they must fall a sacrifice to the Romans, he laid hold of that opportunity to return to Italy. His fleet was attacked by that of Carthage; and his army, after their landing, by the Mamertines. But Pyrrhus having, by his bravery, escaped all danger, marched along the sea shore, to reach Tarentum that way. As he passed through the country of the Locrians, who had massacred the troops he had left there, he not only exercised all sorts of cruelty on the inhabitants, but plundered the temple of Proserpine. The immense riches which he found there were, by his order, sent to Tarentum by sea; but the ships that carried them being dashed against the rocks by a tempest, and the mariners all lost, this proud prince, considering it as a judgment from the gods, caused all the treasures which the sea had thrown upon the shore to be carefully gathered up, and replaced in the temple; and put all those to death who had advised him to plunder the temple. Pyrrhus at length arrived at Tarentum; but of the army he had carried into Sicily he brought back into Italy only 2000 horse and not 20,000 foot. He therefore reinforced them with the best troops he could raise in the countries of the Samnites, Lucanians, and Bruttians; and hearing that the two new consuls, Curius Dentatus and

Cornelius Lentulus, had divided their forces, the one invading Lucania and the other Samnium, he likewise divided his army into two bodies, marching with his Epirots against Dentatus, in hopes of surprising him in his camp near Beneventum. But the consul went out of his entrenchments with a strong detachment of legionaries to meet him, repulsed his van-guard, put many of the Epirots to the sword, and took some of their elephants. Curius then marched his army into the Taurasian fields, and drew it up in a plain wide enough for his own troops, but too narrow for the Epirot phalanx. But the king's eagerness to try his skill with so renowned a commander, made him engage at that great disadvantage; the consequence of which was that the Romans obtained a complete victory. Oro-sius and Eutropius tell us that Pyrrhus's army consisted of 80,000 foot and 6000 horse, including his Epirots and allies; whereas the consular army was scarcely 20,000 strong. Some say that the king's loss amounted to 30,000 men; others reduce it to 20,000. All agree that Curius took 1200 prisoners and eight elephants. This victory, which was the most decisive Rome had ever gained, brought all Italy under subjection, and paved the way for those vast conquests which followed. Pyrrhus being not in a condition, after this great loss, to keep the field, retired to Tarentum, attended only by a small body of horse, leaving the Romans in full possession of his camp; which they so much admired that they made it ever after a model by which to form their own. And now he resolved to leave Italy, but concealed his design. Accordingly he despatched ambassadors into Ætolia, Illyricum, and Macedon, demanding supplies of men and money; and, having at last pretended to be in a great rage at the dilatoriness of his friends in sending him succors, acquainted the Tarentines that he must go and bring them over himself. However he left behind him a strong garrison in the citadel of Tarentum under Milo. After these precautions Pyrrhus set sail from Epirus, and arrived safe at Acroceraunium with 8000 foot and 500 horse; after having spent to no purpose six years in Italy and Sicily.

Though, in the manner in which Pyrrhus took his leave, his Italian allies had little reason to expect any further assistance from him, yet they continued to indulge vain hopes, till certain accounts arrived of his being killed at the siege of Argos. This threw the Samnites into despair: so that they put all to the issue of a general battle; in which they were defeated with such dreadful slaughter that the nation was almost exterminated. This overthrow was soon followed by the submission of the Lucanians, Bruttians, Tarentines, Sarcinates, Picentes, and Salentines; so that Rome now became mistress of all the nations from the remotest parts of Etruria to the Ionian Sea, and from the Tyrrhenian Sea to the Adriatic. All these nations, however, did not enjoy the same privileges. Some were entirely subject to the republic; others retained their old laws and customs. Some were tributary; and others allies, who were obliged to furnish troops at their own expense, when the Romans required. Some had the privilege of Roman citizenship,

their soldiers being incorporated in the legions; while others had a right of suffrage in the elections made by the centuries. These different degrees of honor, privileges, and liberty, were founded on the different terms granted to the conquered nations when they surrendered, and were afterwards increased according to their fidelity, and the services they did the republic. The Romans now became respected by foreign nations, and received ambassadors from Ptolemy Philadelphus king of Egypt, and from Apollonia, a city of Macedon. Sensible of their own importance, they granted protection to whatever nation requested it of them; not with a view of serving one party, but that they might subject both. In this manner they assisted the Mamertines against Hiero, king of Syracuse, which brought on the wars with the Carthaginians, which terminated in the total destruction of that ancient republic, as related under **CARTHAGE**.

The interval between the first and second Punic wars was by the Romans employed in reducing the Boii and Ligurians, who had revolted. These were Gaulish nations, who had always been very formidable to the Romans, and now gave one of their consuls a notable defeat. However, he soon after defeated them with great slaughter; though it was not till some time after that, and with great difficulty, that they were totally subdued. During this interval, also, the Romans seized on the islands of Sardinia, Corsica, and Malta, and in 219 B. C. the two former were reduced to the form of a province. Papirius, who had subdued Corsica, demanded a triumph; but, not having interest enough to obtain it, he took a method entirely new to do himself justice. He put himself at the head of his victorious army, and marched to the temple of Jupiter Latiaris, on the hill of Alba, with all the pomp that attended triumphant victors at Rome. He made no other alteration in the ceremony but that of wearing a crown of myrtle instead of a crown of laurel, and this on account of his having defeated the Corsicans in a place where there was a grove of myrtles. The example of Papirius was afterwards followed by many generals to whom the senate refused triumphs. The next year, when M. Æmilius Barbula and M. Junius Pera were consuls, a new war sprung up in a kingdom out of Italy. Illyricum, which bordered upon Macedon and Epirus, was at this time governed by Teuta, the widow of king Agron, and guardian to her son Pinæus, a minor. Her pirates had taken and plundered many ships belonging to the Romans, and her troops were then besieging the island of Issa, in the Adriatic whose inhabitants were under the protection of the public. Upon the complaints therefore of the Italian merchants, and to protect the people of Issa, the senate sent two ambassadors to the Illyrian queen, Lucius and Caius Coruncanus, to demand of her that she would restrain her subjects from infesting the sea with pirates. She answered them haughtily; they replied in a similar strain, which provoked Teuta to such a degree that she caused them to be murdered on their return. When so notorious an infraction of the law of nations was known at Rome, the

people demanded vengeance; and the senate having erected, as usual in such cases, statues three feet high to their memory, ordered a fleet to be equipped, and troops raised, with expedition. But Teuta sent an embassy to Rome, assuring the senate that she had no hand in the murder of the ambassadors, and offering to deliver up to the republic those who had committed it. The Romans, being threatened with a war from the Gauls, were ready to accept this satisfaction; but the Illyrian fleet having gained some advantage over that of the Achæans, and taken the island of Corcyra near Epirus, this success made Teuta believe herself invincible, and she disregarded her promise to the Romans; she even sent her fleet to seize on the island of Issa, which they had taken under their protection. Hereupon the consuls, P. Posthumius Albinus and Cn. Fulvius Centumalus, embarked for Illyricum: Fulvius having the command of the fleets, which consisted of 100 galleys; and Posthumius of the land forces, which amounted to 20,000 foot, besides a small body of horse. Fulvius appeared with his fleet before Corcyra, and was put in possession both of the island and city by Demetrius of Pharos, governor for queen Teuta. Nor was this all; Demetrius made the inhabitants of Apollonia drive out the Illyrian garrison, and admit into their city the Roman troops. The Andlyæans, Parthini, and Atintanes, soon after submitted to Posthumius, being induced by the persuasions of Demetrius to shake off the Illyrian yoke. The consul, being now in possession of most of the inland towns, returned to the coast, where, with the assistance of the fleet, he took many strong holds, among which was Nutria, a place of great strength, with a numerous garrison. The loss of the Romans was repaired by the capture of forty Illyrian vessels, which were returning home with booty. At length the Roman fleet appeared before Issa, which, by Teuta's order, was still closely besieged, notwithstanding her losses. However, upon the approach of the Roman fleet, the Illyrians dispersed; but the Pharians, who served among them, followed their countryman Demetrius, and joined the Romans, to whom the Issani submitted. Sp. Corvilius and Q. Fabius Maximus being again raised to the consulate, Posthumius was called from Illyricum, and refused a triumph for having been too prodigal of blood at the siege of Nutria. His colleague Fulvius was appointed to command the land forces as proconsul. Hereupon Teuta retired to one of her strong holds called Rhizon, and thence early in spring sent an embassy to Rome. The senate refused to treat with her; but granted the young king a peace upon condition: 1. That he should pay an annual tribute; 2. That he should surrender part of his dominions; 3. That he should never suffer above three of his ships of war at a time to sail beyond Lyffus. The places he yielded to the Romans by this treaty were the islands of Corcyra, Issa, and Pharos, the city of Dyrrhachium, and the country of the Atintanes. Soon after Teuta abdicated the regency, and Demetrius succeeded her. Before this war was ended, the Romans were alarmed by new motions of the Gauls, and the great pro-

gress which the Carthaginians made in Spain. At this time also the fears of the people were excited by a prophecy said to be taken out of the Sybilline books, that the Gauls and Greeks should one day be in possession of Rome. This prophecy, however, the senate found means to elude, by burying two Gauls and two Greeks alive, and then telling the multitude that the Gauls and Greeks were now in possession of Rome. The Romans now made vast preparations against the Gauls. Some say that the number of forces raised by their republic on this occasion amounted to no fewer than 800,000 men. Of this incredible multitude 248,000 foot, and 26,000 horse, were Romans or Campanians; yet the Gauls, with only 50,000 foot and 20,000 horse, forced a passage through Etruria, and took the road towards Rome. Here they at first defeated one Roman army; but, being soon after met by two others, they were utterly defeated, with the loss of more than 50,000 men. The Romans then entered their country, which they cruelly ravaged; but a plague breaking out obliged them to return home. This was followed by a new war, in which those Gauls who inhabited Insubria and Liguria were totally subdued, and their country reduced to a Roman province. These conquests were followed by that of Istria; Dimalun, a city of importance in Illyricum; and Pharos, an island in the Adriatic Sea. The second Punic war for some time retarded the conquests of the Romans, and even threatened their state with entire destruction; but Hannibal being at last recalled from Italy, and entirely defeated at Zama, they made peace upon such advantageous terms as gave them an entire superiority over that republic, which they not long after entirely subverted. See **CARTHAGE**.

The successful issue of the second Punic war had greatly increased the extent of the Roman empire. They were now masters of all Sicily, the Mediterranean Islands, and great part of Spain; and, through the dissensions of the Asiatic states with the king of Macedon, a pretence was now found for carrying their arms into these parts. The Gauls, however, continued their incursions, but now ceased to be formidable; while the kings of Macedon were first obliged to submit to a disadvantageous peace, and at last totally subdued. See **MACE DON**. The reduction of Macedon was soon followed by that of all Greece, either under the name of allies or otherwise; while Antiochus the Great, to whom Hannibal fled for protection, by an unsuccessful war, first gave the Romans a footing in Asia. See **SYRIA**. The Spaniards and Gauls continued to be the most obstinate enemies. The former, particularly, were rather exterminated than reduced; and even this required the utmost care and vigilance of Scipio Æmilianus, the conqueror of Carthage, to execute. See **SPAIN** and **NUMANTIA**. Thus the Romans attained to a height of power superior to any other nation; but now a sedition broke out, which we may say was never terminated but with the overthrow of the republic. This had its origin from Tiberius Sempronius Gracchus, descended from a family which, though plebeian, was as illustrious as any

in the commonwealth. His father had been twice consul, was a great general, and had been honored with two triumphs. But he was still more renowned for his domestic virtues and probity than for his birth or valor. He married Cornelia, the daughter of the first Scipio Africanus, the pattern of her sex, and the prodigy of her age; and had by her several children, of whom three arrived to maturity of age, Tiberius Gracchus, Caius Gracchus, and a daughter, Sempronia, who was married to Scipio Africanus Junior, or Æmilianus. Tiberius, the eldest, was deemed the most accomplished youth in Rome, with respect to the qualities both of body and mind. He made his first campaigns under his brother-in-law, and distinguished himself by his courage and prudence. When he returned to Rome he applied himself to the study of eloquence; and at thirty years of age was accounted the best orator of his day. He married the daughter of Appius Claudius, who had been consul and censor, and was the chief author and negotiator of that peace with the Numantines which the senate, with the utmost injustice, disannulled. He stood for the tribuneship of the people; which he no sooner obtained than he resolved to attack the nobility in the most tender parts. They had usurped lands unjustly, cultivated them by slaves, to the great detriment of the public; and had lived for about 250 years in an open defiance to the Licinian law, by which it was enacted that no citizen should possess more than 500 acres. This law Tib. Gracchus resolved to revive. As he first drew it up it was very mild; for it only enacted, that those who possessed more than 500 acres of land should part with the overplus; and that the full value of the said lands should be paid them out of the public treasury. The lands thus purchased by the public were to be divided among the poor citizens; and cultivated either by themselves or by freemen, who were upon the spot. He allowed every child to hold 250 acres. This law, even in so mild a shape, was strenuously opposed by the senate, and by one of his fellow tribunes Marcus Octavius Cæcina. The consequence was, that he procured the deposition of the latter, and, irritated by opposition, he had influence enough to have the law revived as it was at first passed, without abating any thing of its severity. There was no exception in favor of the children in families; or reimbursement promised to those who should part with the lands they possessed above 500 acres. The Licinian law being thus revived with one consent, both by the city and country tribes, Gracchus caused the people to appoint three commissioners, to hasten its execution. The commission was held by Gracchus, his father-in-law Appius Claudius, and his brother Caius Gracchus. These three spent the whole summer in travelling through the Italian provinces, to examine what lands were held by any person above 500 acres, in order to divide them among the poor citizens. On a strict enquiry they found that the lands taken from the rich would be enough to content all the poor citizens. But the following circumstance eased Gracchus of this difficulty. Attalus Philometer, king of Pergamus, having bequeathed his domi-

nions and effects to the Romans, Gracchus immediately got a new law passed, enacting that this money should be divided among the poor citizens who could not have lands, and that the disposal of the revenues of Pergamus should not be in the senate, but in the comitia. By these steps Gracchus most effectually humbled the senate. In order to continue his power, he projected, and indeed almost effected, his re-election to the office of tribune; but the patricians, being determined to effect his fall, took advantage of a report that had been circulated of his intention of aspiring to sovereignty, and slew him in a tumult on the day of election.

The death of Gracchus did not put an end to the tumult. Above 300 of the tribune's friends lost their lives also; and, their bodies were thrown with that of Gracchus, into the Tiber. Nay, the senate carried their revenge beyond the fatal day which had stained the capitol with Roman blood. They sought for all the friends of the late tribune, and without any form of law assassinated some, and forced others into banishment. These disturbances were for a short time interrupted by a revolt of the slaves in Sicily, occasioned by the cruelty of their masters; but, they being soon reduced, the contests about the Sempronian law, as it was called, again took place. Both parties were determined not to yield; and therefore the most fatal effects ensued. The first thing of consequence was the death of Scipio Africanus the younger, who was privately strangled in his bed by some of the plebeian party, about 129 B. C. Caius Gracchus, brother to Tiberius, not only undertook the revival of the Sempronian law, but proposed a new one, granting the rights of Roman citizens to all the Italian allies, who could receive no share of the lands divided in consequence of the Sempronian law. The effects of this were much worse than the former; the flame spread through all Italy; and the nations who had made war with the republic in its infancy again commenced enemies more formidable than before. Fragellæ, a city of the Volsci, revolted; but, being suddenly attacked, was obliged to submit, and was razed to the ground. Gracchus, however, still continued his attempts to humble the senate and the patricians: the ultimate consequence of which was, that a price was set on his head and that of Fulvius his confederate, no less than their weight in gold, to any one who should bring them to Opimius the chief of the patrician party. Thus the custom of proscription was begun by the patricians, of which they themselves soon had enough, and they certainly merited it. Gracchus and Fulvius were sacrificed, but the disorders of the republic were not so easily cured.

The inroad of the Cimbri and Teutones put a stop to the civil discords for some time longer; but, they being defeated, nothing prevented the troubles from being revived with greater fury than before, except the war with the Sicilian slaves, which had again commenced with more dangerous circumstances than ever. But this being ended, about 99 B. C., no farther obstacle remained. Marius the conqueror of Jugurtha (see NUMIDIA) and the Cimbri undertook the cause of the plebeians against the senate and

patricians. Having associated himself with Apuleius and Glaucia, two factious men, they carried their proceedings to such a length that an open rebellion commenced, and Marius himself was obliged to act against his allies. Peace, however, was restored by the massacre of Apuleius and Glaucia, with a great number of their followers; upon which Marius left the city. While factious men thus endeavoured to tear the republic in pieces, the attempts of the well-meaning to heal those divisions served only to involve the state in calamities still more grievous. The consuls observed that many individuals of the Italian allies lived at Rome, and falsely pretended to be Roman citizens. By means of them the plebeian party had acquired a great deal of power, as the votes of these pretended citizens were always at the service of the tribunes. The consuls, therefore, passed a law, commanding all those pretended citizens to return home. This was so much resented by the Italian states that a universal defection took place. A scheme was then formed by M. Livius Drusus, a tribune of the people, to reconcile all parties; but this only made matters worse, and procured his own assassination. His death seemed a signal for war. The Marsi, Peligni, Samnites, Campanians, and Lucanians, and all the provinces from the Liris to the Adriatic, revolted at once, and formed themselves into a republic in opposition to that of Rome. The haughty Romans were now made thoroughly sensible that they were not invincible; they were defeated in almost every engagement; and must soon have yielded, had they not fallen upon a method of dividing their enemies. A law was passed, enacting that all the nations in Italy, whose alliance with Rome was indisputable, should enjoy the right of Roman citizens. This drew off several nations from their alliance; and, Sylla taking upon him the command of the Roman armies, fortune soon declared in favor of the latter. Yet the success of Rome against the allies served only to bring greater miseries upon herself. Marius and Sylla became rivals; the former adhering to the people, and the latter to the patricians. Marius associated with one of the tribunes named Sulpitius, in conjunction with whom he raised such disturbances that Sylla was forced to retire from the city. Having thus driven off his rival, Marius got himself appointed general against Mithridates, king of Pontus. See PONTUS. But the soldiers refused to obey any other than Sylla. A civil war ensued, in which Marius was driven out in his turn, and a price set upon his head and that of Sulpitius, and their adherents. Sulpitius was soon seized and killed; but Marius escaped. In the mean time, however, the cruelties of Sylla rendered him obnoxious both to the senate and people; and Cinna, a furious partisan of the Marian faction, being chosen consul, cited him to give an account of his conduct. Upon this Sylla set out for Asia; Marius was recalled from Africa, whither he had fled; and, immediately on his landing in Italy, was joined by a great number of shepherds, slaves, and men of desperate fortunes; so that he soon had a considerable army. Cinna, whom the senators had deposed and driven out of Rome, solicited and obtained a powerful army from the

allies; and being joined by Sertorius, a most able and experienced general, the two, in conjunction with Marius, advanced towards the capital; and, as their forces daily increased, a fourth army was formed under Papirius Carbo. The senate raised some forces to defend the city; but, these being vastly inferior in number and inclined to the contrary side, they were obliged to open their gates to the confederates. Marius entered at the head of a numerous guard, composed of slaves, whom he called his Bardiaeans, and whom he designed to employ in revenging himself on his enemies. The first order he gave these assassins was, to murder all who came to salute him and were not answered with the like civility. As every one was forward to pay his compliments to the new tyrant this order proved the destruction of vast numbers. At last, these Bardiaeans abandoned themselves to such excesses in every kind of vice, that Cinna and Sertorius ordered their troops to fall upon them; which, being instantly put in execution, they were all cut off to a man. By the destruction of his guards Marius was reduced to the necessity of taking a method of gratifying his revenge somewhat more tedious, though equally effectual. A conference was held between the four chiefs, in which a resolution was taken to murder without mercy all the senators who had opposed the popular faction. A general slaughter commenced, which lasted five days, during which the greatest part of the obnoxious senators were cut off, their heads stuck upon poles over against the rostra, and their bodies dragged with hooks into the forum, where they were left to be devoured by dogs. Sylla's house was demolished, his goods confiscated, and he himself declared an enemy to his country; however his wife and children escaped. This massacre was not confined to the city of Rome. The soldiers were dispersed over the country in search of those who fled; and many gave up their friends who had fled to them for shelter.

This slaughter being over, Cinna named himself and Marius consuls for the ensuing year; and these tyrants seemed resolved to begin the new year as they had ended the old one: but, while they were preparing to renew their cruelties, Sylla, having proved victorious in the east, sent a long letter to the senate, giving an account of his many victories, and his resolution of returning to Rome to revenge himself of his enemies. This letter occasioned a universal terror. Marius, dreading to enter the lists with such a renowned warrior, gave himself up to excessive drinking, and died. His son was associated with Cinna in the government, though not in the consulship, and proved a tyrant no less cruel than his father. The senate declared Valerius Flaccus general of the forces in the east, and appointed him a considerable army; but the troops, all to a man, deserted him and joined Sylla. Soon after Cinna declared himself consul a third time, and took for his colleague Papirius Carbo; but the citizens, dreading the tyranny of these monsters, fled in crowds to Sylla, who was now in Greece. To him the senate sent deputies, begging that he would have compassion on his country, and not carry his resentment to



such a length as to begin a civil war: but he replied that he was coming to Rome full of rage and revenge; and that all his enemies should perish, either by the sword or the axes of the executioners. Upon this several very numerous armies were formed against him; but were every where defeated, or went over to the enemy. Pompey, afterwards styled the Great, embraced the party of Sylla. The Italian nations took some one side and some another. Cinna was killed in a tumult, and young Marius and Carbo succeeded him; but the former, having ventured an engagement with Sylla, was by him defeated, and forced to fly to Præneste, where he was closely besieged. Thus was Rome reduced to the lowest degree of misery; when one Pontius Telesinus, a Samnite, projected the total ruin of the city. He had joined, or pretended to join, the generals of the Marian faction with an army of 40,000 men; and therefore marched towards Præneste, as if he designed to relieve Marius. By this manœuvre he drew Sylla and Pompey away from the capital; and then, decamping in the night, overreached these two generals, and by break of day was within ten furlongs of the Collatine gate. He now, declaring himself as much an enemy to Marius as to Sylla, told his troops that it was not his design to assist one Roman against another, but to destroy the whole race. 'Let fire and sword,' said he, 'destroy all; let no quarter be given; mankind can never be free as long as one Roman is left alive.' Never had this proud metropolis been in greater danger; nor ever had any city a more narrow escape. The Roman youth marched out to oppose him, but were driven back with great slaughter. Sylla himself was defeated, and forced to fly to his camp. Telesinus advanced with increased confidence; but, in the mean time, M. Crassus having defeated the other wing of his army, he attacked the body where Telesinus commanded, and by putting them to flight saved his country. Sylla having now no enemy to fear, marched first to Atennæ, and thence to Rome. From the former city he carried 8000 prisoners to Rome, and caused them all to be massacred at once in the circus. His cruelty next fell upon the Prænestines, 12,000 of whom were massacred without mercy. Young Marius had killed himself, to avoid falling into his hands. Soon after the inhabitants of Norba, a city of Campania, finding themselves unable to resist the forces of the tyrant, set fire to their houses, and all perished in the flames. The taking of these cities put an end to the civil war, but not to the cruelties of Sylla. Having assembled the people in the comitium, he told them that he was resolved not to spare a single person who had borne arms against him. This cruel resolution he put in execution with the most unrelenting vigor; and, having at last cut off all those whom he thought capable of opposing him, Sylla caused himself to be declared perpetual dictator. This revolution happened about 80 B. C., and from this time we may date the loss of the Roman liberty. Sylla indeed resigned his power in two years; but the citizens of Rome, having once submitted, were ever after ready to submit to a master.

Though individuals retained the same enthusiastic notions of liberty as before, yet the minds of the generality seem from this time to have inclined towards monarchy. New masters were indeed already prepared for the republic.

Cæsar and Pompey had eminently distinguished themselves by their martial exploits, and were already rivals. Sertorius, one of the generals of the Marian faction, and the only one of them possessed either of honor or probity, had retired into Spain, where he erected a republic independent of Rome. Pompey and Metellus, two of the best reputed generals in Rome, were sent against him; but, instead of conquering, they were on all occasions conquered by him. At last Sertorius was treacherously murdered; and the traitors, who after his death usurped the command, being totally destitute of his abilities, were easily defeated by Pompey: and thus that general reaped an undeserved honor from concluding the war with success. The Spanish war was scarcely ended when a very dangerous one was excited by Spartacus, a Thracian gladiator. For some time this rebel proved very successful: but at last was defeated and killed by Crassus. The fugitives, however, rallied again, to the number of 5000; but, being defeated by Pompey, the latter took occasion to claim the glory due to Crassus. Being thus become extremely popular, he was chosen consul along with Crassus. Both generals were at the head of powerful armies, and a contest instantly began betwixt them. With difficulty they were in appearance reconciled, but began to oppose one another in a new way. Pompey courted the favor of the people, by reinstating the tribunes in their ancient power, which had been greatly abridged by Sylla. Crassus, though very covetous, entertained the populace with surprising profusion at 10,000 tables, and distributed corn among their families. He was the richest man at this time in Rome, his estate being valued at upwards of 7000 talents, i. e. £1,355,250 sterling. Pompey, however, still had the superiority; and was therefore proposed as a proper person for clearing the seas of pirates. He was to have an absolute authority for three years over all the seas within the pillars of Hercules, and over all the countries for 400 furlongs from the sea. He was empowered to raise as many soldiers and mariners as he thought proper; to take what sums of money he pleased out of the public treasury, without being accountable; and to choose out of the senate fifteen senators to be his lieutenants, and execute his orders when he himself could not be present. The sensible part of the people were against investing one man with so much power; but the unthinking multitude rendered all opposition fruitless. This law being agreed to, Pompey executed his commission so much to the public satisfaction that on his return a new law was proposed, appointing him general of all the forces in Asia; and, as he was still to retain the sovereignty of the seas, he was now in fact made sovereign of all the Roman empire. Cicero and Cæsar supported this law, the former aspiring at the consulate, and the latter pleased to see the Romans

appointing themselves a master. Pompey, however, executed his commission with fidelity and success, completely conquering Pontus, Albania, Iberia, &c., which had been begun by Sylla and Lucullus. But, while Pompey was thus aggrandising himself, the republic was on the point of being subverted by a conspiracy formed by Lucius Sergius Catiline. He was descended from an illustrious family; but having ruined his estate, and rendered himself infamous by a series of detestable crimes, he associated with a number of others in similar circumstances. Their scheme was to murder the consuls with the greatest part of the senators, set fire to the city, and seize the government. This design miscarried twice; but was not dropped by the conspirators. At last it was discovered by a young knight, who had revealed the secret to his paramour. Catiline then openly took the field, and raised a considerable army: but was defeated and killed about 62 B. C. In the mean time Cæsar continued to advance in popularity and in power. Soon after the defeat of Catiline he was created pontifex maximus; and after that was sent into Spain, where he subdued several nations that had never been subject to Rome. Mean time Pompey returned from the east, and was received with the highest honors; but he affected extraordinary modesty, and declined accepting a triumph. His aim was to assume a sovereign authority without seeming to desire it. He therefore renewed his intrigues, and spared no pains to increase his popularity. Cæsar, on his return from Spain, found the sovereignty divided between Crassus and Pompey. No less ambitious than either, Cæsar proposed that they should put an end to their differences, and take him for a partner. In short, he projected a triumvirate (Pompey, Crassus, and himself), in which should be lodged the whole power of the senate and people; and they bound themselves by mutual oaths to stand by each other, and suffer nothing to be undertaken or carried into execution without the unanimous consent of all the three. Thus was the liberty of the Romans a second time taken away; nor did they ever afterwards recover it, though few perceived this, at the time, except Cato. The association of the triumvirs was for a long time kept secret; and nothing appeared to the people except the reconciliation of Pompey and Crassus, for which the state reckoned itself indebted to Cæsar.

The first consequence of the triumvirate was the consulship of Julius Cæsar, obtained by the favor of Pompey and Crassus. Cæsar set himself to engage the affections of the people; and this he did, by an agrarian law, so effectually, that he was in a manner idolised. This law was in itself very reasonable and just; nevertheless the senate, perceiving the design with which it was proposed, thought themselves bound to oppose it. But their opposition proved fruitless: the consul Bibulus, who showed himself most active in his endeavours against it, was driven out of the assembly with the greatest indignity; so that Cæsar was reckoned sole consul. The next step taken by Cæsar was to secure the knights, and for this purpose he abated a third of the rents which they annually paid into the

VOL. XVIII.

treasury; after which he governed Rome with an absolute sway during the time of his consulate. The reign of this triumvir, however, was ended by his expedition into Gaul, where his military exploits acquired him the highest reputation. Pompey and Crassus therefore became consuls, and governed as despotically as Cæsar. On the expiration of their first consulate, the republic fell into a kind of anarchy. At last, however, this confusion was ended by raising Crassus and Pompey again to the consulate. This was no sooner done than a new partition of the empire was proposed. Crassus was to have Syria and all the eastern provinces, Pompey was to govern Africa and Spain, and Cæsar to be continued in Gaul for five years. The law was passed by a great majority; upon which Crassus undertook an expedition against the Parthians. Cæsar applied with great assiduity to the completing of the conquest of Gaul; and Pompey staid at Rome to govern the republic. The affairs of the Romans were now hastening to a crisis. Crassus, having oppressed all the provinces of the east, was totally defeated and killed by the Parthians; after which the two great rivals, Cæsar and Pompey, were left alone. Matters, however, continued pretty quiet, till Gaul was reduced to a Roman province. The question then was, whether Cæsar or Pompey should first resign the command of their armies, and return to the rank of private persons. As both parties saw that whoever first laid down his arms must of course submit to the other, both refused. As Cæsar, however, had amassed immense riches in Gaul, he was now in a condition not only to maintain an army capable of vying with Pompey, but even to buy over the leading men in Rome to his interest. One of the consuls, named Æmilius Paulus, cost him no less than 1500 talents, or £310,625 sterling; but the other, named Marcellus, could not be gained at any price. Pompey had put at the head of the tribunes one Scribonius Curio, a young patrician of great abilities, but so exceedingly debauched and extravagant that he owed upwards of £4,500,000 of our money. Cæsar, by enabling him to satisfy his creditors, and supplying him with money to pursue his debaucheries, secured him in his interest; and Curio, without seeming to be in it, did him the most essential service. He proposed that both generals should be recalled; being assured that Pompey would never consent to part with his army, so that Cæsar might make this a pretence for continuing in his province at the head of his troops: and thus, while both professed pacific intentions, both continued ready for the most obstinate and bloody war. Cicero took upon himself the office of mediator; but Pompey would hearken to no terms of accommodation. In the year 49 B. C. the senate passed a decree by which Pompey was invested with the command of the troops of the republic, Cæsar divested of his office, and Lucius Domitius appointed to succeed him: the new governor being empowered to raise 4000 men to take possession of his province. War being thus resolved on, the senate and Pompey began to prepare for opposing Cæsar. They ordered 30,000 Roman soldiers

3 A

to be assembled, with as many Roman troops as Pompey should think proper: the expense of which was defrayed from the public treasury. The governments of provinces were bestowed upon such as were remarkable for their attachment to Pompey. Cæsar, however, took care of his own interest: three of the tribunes who had been his friends were driven out of Rome, and arrived in his camp disguised like slaves. Cæsar showed them to his army in this ignominious habit; and, setting forth the iniquity of the senate and patricians, exhorted his men to stand by their general under whom they had served so long with success; and, finding by their acclamations that he could depend on them, he resolved to begin hostilities immediately.

Cæsar's first design was to make himself master of Ariminum, a city bordering upon Cisalpine Gaul, but he resolved to keep his design private. At that time he himself was at Ravenna, whence he sent a detachment towards the Rubicon, desiring the officer who commanded it to wait for him on the banks of that river. The next day he assisted at a show of gladiators, and made a great entertainment. Towards the close of the day he rose from table, desiring the guests to stay till he came back; but, instead of returning to the company, he set out for the Rubicon, having left orders to his most intimate friends to follow him through different roads, to avoid being observed. Having arrived at the Rubicon, which parted Cisalpine Gaul from Italy, the misfortunes of the empire occurred to his mind, and made him hesitate. Turning then to Asinius Pollio, 'If I do not cross the Rubicon,' said he, 'I am undone; and, if I do cross it, how many calamities shall I by this means bring upon Rome!' Having thus spoken, he mused a few minutes; and then, crying out 'the die is cast,' he threw himself into the river, and, crossing it, marched with all possible speed to Ariminum, which he reached and surprised before day-break. Thence, as he had but one legion with him, he despatched orders to the army he had left in Gaul to cross the mountains and join him. The activity of Cæsar struck the opposite party with the greatest terror. Pompey, no less alarmed than the rest, left Rome with a desire to retire to Capua, where he had two legions draughted formerly out of Cæsar's army. He communicated his intended flight to the senate; but acquainted them that, if any magistrate or senator refused to follow him, he should be treated as an enemy to his country. In the mean time Cæsar, having raised new troops in Cisalpine Gaul, sent Marc Antony with a detachment to seize Aretium, and some other officers to secure Pisaurum and Fanum, while he himself marched at the head of the thirteenth legion to Auximum, which opened its gates to him. From Auximum he advanced into Picenum, where he was joined by the twelfth legion from Transalpine Gaul. As Picenum submitted, he led his forces against Corfinium, the capital of the Peligni, which Domitius Ahenobarbus defended with thirty cohorts. But Cæsar no sooner invested it than the garrison betrayed their commander, and delivered him up with many senators, who had taken refuge in the place, to Cæsar, who granted

them their lives and liberty. Pompey, thinking himself no longer safe at Capua after the reduction of Corfinium, retired to Brundisium, to carry the war into the east, where all the governors were his creatures. Cæsar followed him close; and, arriving with his army before Brundisium, invested the place on the land side, and undertook to shut up the port by a staccado of his own invention. But, before the work was completed, the fleet which had conveyed the two consuls with thirty cohorts to Dyrrhachium being returned, Pompey resolved to make his escape, which he did with all the dexterity of a great officer. He kept his departure very secret; but made all necessary preparations for facilitating it. Walling up the gates, he dug deep and wide ditches cross all the streets, except only two that led to the port; in the ditches he planted sharp pointed stakes, covering them with hurdles and earth. After these precautions, he gave express orders that all the citizens should keep within doors, lest they should betray his design; and then, in three days, embarked all his troops, except the light armed infantry, whom he had placed on the walls; these likewise, on a signal given, abandoning their posts, repaired with great expedition to the ships. Cæsar, perceiving the walls unguarded, ordered his men to scale them, and make what haste they could after the enemy. In the heat of the pursuit they would have fallen into the ditches which Pompey had prepared for them, had not the Brundisians warned them of the danger. In the haven they found all the fleet under sail, except two vessels, which had run aground in going out of the harbour. These Cæsar took, made the soldiers on board prisoners, and brought them ashore. Seeing himself, by the flight of his rival, thus master of all Italy from the Alps to the sea, Cæsar wished to follow and attack Pompey before he received his supplies from Asia. But, being destitute of shipping, he resolved to go to Rome, and settle the government there; then pass into Spain to expel Pompey's troops, who had possession of that great peninsula, under Afranius and Petreius. Before he left Brundisium he sent Scribonius Curio with three legions into Sicily, and ordered Q. Valerius, one of his lieutenants, to get together what ships he could, and cross over with one legion into Sardinia. Cato, who commanded in Sicily, upon the first news of Curio's landing there, abandoned the island, and retired to the camp of the consuls at Dyrrhachium; and Q. Valerius no sooner appeared with his small fleet off Sardinia, than the Caralitini (the inhabitants of what is now called Cagliari), drove out Aurelius Cotta, who commanded there for the senate, and put Cæsar's lieutenant in possession both of their city and island. In the mean time Cæsar advanced towards Rome, and on his march wrote to all the senators then in Italy, desiring them to repair to the capital, and assist him with their counsel. Above all, he was desirous to see Cicero; but could not prevail upon him to return to Rome. As Cæsar drew near the capital, he quartered his troops in the neighbouring municipia; and then advancing to the city, out of respect to ancient custom, he took up his quarters in the suburbs, whither the whole city

crowded to see the conqueror of Gaul, who had been absent nearly ten years. Such of the tribunes of the people as had fled to him for refuge reassumed their functions, mounted the rostra, and endeavoured to reconcile the people to the head of their party. Marc Antony particularly, and Cassius Longinus, moved that the senate should meet in the suburbs, that Cæsar might give them an account of his conduct. Accordingly, such of the senators as were at Rome assembled; when Cæsar made a speech in justification of all his proceedings, and concluded his harangue with proposing a deputation to Pompey, with offers of an amicable accommodation. He even desired the senate, to whom he paid great deference, to nominate some of their venerable body to carry proposals of peace to the consuls, and the general of the consular army; but none of the senators would take upon him that commission. He then, to provide himself with money for carrying on the war, had recourse to the public treasury. Metellus, one of the tribunes, opposed him: but Cæsar, laying his hand on his sword, threatened to kill him, and Metellus withdrew. Cæsar took out of the treasury, which was ever after at his command, an immense sum; some say 300,000 pounds weight of gold. With this supply of money he raised troops all over Italy, and sent governors into all the provinces subject to the republic. Cæsar now made Marc Antony commander-in-chief of the armies in Italy, sent his brother C. Antonius to govern Illyricum, assigned Cisalpine Gaul to Licinius Crassus, appointed M. Æmilius Lepidus governor of the capital; and, having got together some ships to cruise in the Adriatic and Mediterranean seas, he gave the command of one of his fleets to P. Cornelius Dolabella, and of the other to young Hortensius, son of the famous orator. As Pompey had sent governors into the same provinces, a war was thus kindled in almost all the parts of the known world. However, Cæsar would not trust any of his lieutenants with the conduct of the war in Spain, which was Pompey's favorite province, but took it upon himself; and, having settled his affairs at Rome, returned to Ariminum, and assembled his legions there.

In Transalpine Gaul he was informed that the inhabitants of Marseilles had resolved to refuse him entrance into their city, and that L. Domitius Ahenobarbus, whom he had generously pardoned and set at liberty after the reduction of Corfinium, had set sail for Marseilles with seven galleys, having on board a great number of his clients and slaves, with a design to raise the city in favor of Pompey. Cæsar sent for the fifteen chief magistrates of the city, and advised them to follow the example of Italy, and submit. The magistrates returned to the city, and soon after informed him that they were to stand neuter; but in the mean time Domitius, arriving with his small squadron, was received into the city, and declared general of all their forces. Hereupon Cæsar invested the town with three legions, and ordered twelve galleys to be built at Arelas to block up the port. But as the siege proved tedious he left C. Trebonius to carry it on, and D. Brutus to command the fleet, while

he continued his march into Spain, where he began the war with all the valor, ability, and success of a great general. Pompey had three generals in this peninsula, which was divided into two Roman provinces. Varro commanded in Farther Spain; and Petreius and Afranius, with equal power, and two considerable armies in Hither Spain. Cæsar, while yet at Marseilles, sent Q. Fabius, with three legions, to take possession of the passes of the Pyrenees, which Afranius had seized. Fabius executed his commission with great bravery, entered Spain, and left the way open for Cæsar, who quickly followed him. As soon as he had crossed the mountains, he sent out scouts to observe the enemy; by whom he was informed that Afranius and Petreius having joined their forces, consisting of five legions, twenty cohorts of the natives, and 5000 horse, were advantageously posted on a hill of an easy ascent, in the neighbourhood of Ilerda, in Catalonia. Upon this Cæsar advanced within sight of the enemy, and encamped in a plain between the Sicoris and Cinga, now the Segro and Cinca. Between the eminence on which Afranius had posted himself and the city was a small plain, and in the middle of it a rising ground, which Cæsar attempted to seize, to cut off the communication between the enemy's camp and Ilerda, whence they had all their provisions. This occasioned a sharp dispute between three of Cæsar's legions and an equal number of the enemy, which lasted five hours with equal success, both parties claiming the victory. But Afranius's men, who had first seized the post, maintained it. Two days after this battle, continual rains, with the melting of the snow on the mountains, so swelled the two rivers between which Cæsar was encamped that they overflowed, broke down his bridges, and laid under water the neighbouring country to a great distance. This cut off the communication between his camp and the cities that had declared for him; and reduced him to such straits that his troops were ready to die for famine, wheat being sold in his camp at fifty Roman denarii per bushel, that is, £1 12s. 1½d. sterling. He tried to rebuild his bridges, but in vain, the violence of the stream rendering all his endeavours fruitless. Upon the news of Cæsar's distress, many of the senators, who had hitherto stood neuter, hastened to Pompey's camp. Of this number was Cicero; who, without regard to the remonstrances of Atticus, or the letters Cæsar himself wrote to him, desiring him to join neither party, left Italy, and landed at Dyrrhachium, where Pompey received him with great joy. But the joy of Pompey's party was not long-lived. For Cæsar, after having attempted several times in vain to rebuild his bridges, caused boats to be made with all possible expedition; and while the enemy were diverted by endeavouring to intercept the succors that were sent him from Gaul, he laid hold of that opportunity to convey his boats in the night in carriages twenty-two miles from his camp; where with wonderful quickness a great detachment passed the Sicoris, and encamping on the opposite bank, unknown to the enemy, built a bridge in two days, opened a communication

with the neighbouring country, received the supplies from Gaul, and relieved the wants of his soldiers. Cæsar, being thus delivered from danger, pursued the armies of Afranius and Petreius with such superior address, that he forced them to submit without coming to a battle, and thus became master of all Hither Spain. The two generals disbanded their troops, sent them out of the province, and returned to Italy, after having solemnly promised never to assemble forces again, or make war upon Cæsar. Upon the news of the reduction of Hither Spain, the Spaniards in Farther Spain, and one Roman legion, deserted from Varro, Pompey's governor in that province, which obliged him to surrender his other legion and all his money. Cæsar, having thus reduced Spain in a few months, appointed Cassius Longinus to govern the two provinces with four legions, and then returned to Marseilles, which was just surrendering after a most vigorous resistance. Though the inhabitants had by their late treachery deserved a severe punishment, yet he granted them their lives and liberty; but stripped their arsenals of arms, and obliged them to deliver up all their ships. From Marseilles Cæsar marched into Cisalpine Gaul; and thence to Rome, where he laid the foundation of his future grandeur.

He found the city in a very different state from that in which he had left it. Most of the senators and magistrates were fled to Pompey at Dyrrhachium. However, there were still prætors there; and among them M. Æmilius Lepidus, afterwards a triumvir. The prætor, to ingratiate himself with Cæsar, nominated him dictator by his own authority, and against the inclination of the senate. Cæsar accepted the new dignity; but neither abused his power as Sylla had done, nor retained it so long. During the twelve days of his dictatorship, he governed with great moderation, and gained the affections both of the people and patricians. He recalled the exiles, granted the rights and privileges of Roman citizens to all the Gauls beyond the Po, and, as pontifex maximus, filled up the vacancies of the sacerdotal colleges with his own friends. But the chief use he made of his office was to preside at the election of consuls for the next year, when he got himself and Servilius Isauricus, one of his most zealous partizans, promoted to that dignity. And now being resolved to follow Pompey, and carry the war into the east, he set out for Brundisium, whither he had ordered twelve legions to repair. But on his arrival he found only five. The rest being afraid of the dangers of the sea, and unwilling to engage in a new war, had marched leisurely, complaining of their general for allowing them no respite, but hurrying them continually from one country to another. However Cæsar did not wait for them, but set sail with only five legions and 600 horse in the beginning of January. While the rest were waiting at Brundisium for ships to transport them over into Epirus, Cæsar arrived safe with his five legions in Chaonia, the north part of Epirus, near the Ceraunian mountains. There he landed his troops, and sent the ships back to Brundisium to bring over the legions left behind.

The war he was now entering upon was the most difficult he had yet undertaken. Pompey had for a whole year been assembling his troops from all the eastern countries. When he left Italy he had only five legions; but, since his arrival at Dyrrhachium he had been reinforced with one from Sicily, another from Crete, and two from Syria: 3000 archers, six cohorts of slingers, and 7000 horse, had been sent him by princes in alliance with Rome. All the free cities in Asia had reinforced his army with their best troops; Greece, Asia Minor, Syria, Palestine, Egypt, and all the nations from the Mediterranean to the Euphrates, took up arms in his favor. He had almost all the Roman knights in his squadrons, and his legions consisted mostly of veterans inured to the toils of war. He had also under him some of the best commanders of the republic, who had formerly conducted armies themselves. As for his navy, he had above 500 ships of war, besides a far greater number of small vessels, which were continually cruising on the coasts, and intercepted such ships as carried arms or provisions to the enemy. He had likewise above 200 senators, who formed a more numerous senate than at Rome. Cornelius Lentulus and Claudius Marcellus, the last year's consuls, presided in it at Thessalonica, where he built a stately hall for that purpose. There, on the motion of Cato, it was decreed that no Roman citizen should be put to death but in battle, and that no city subject to the republic should be sacked. They also decreed that they alone represented the Roman senate, and that those who resided at Rome were encouragers of tyranny, and friends of a tyrant. Many persons of eminent probity, who had hitherto stood neuter, now flocked to Cato from all parts. His cause was generally called the good cause, while Cæsar's adherents were looked upon as enemies to their country and abettors of tyranny. As soon as Cæsar landed, he marched to Oricum, in Epirus, which was taken without opposition. The like success attended him at Apollonia, and these two conquests opened a way to Dyrrhachium, where Pompey had his magazines of arms and provisions. But the fleet which he had sent back to Brundisium, to transport the rest of his troops, had been attacked by Bibulus, one of Pompey's admirals, who had taken thirty and inhumanly burnt them with the seamen on board. Bibulus, with 110 ships of war, had also taken possession of all the harbours between Salonium and Oricum; so that the legions at Brundisium could not venture to cross the sea without great danger of falling into the enemy's hands. By this news Cæsar was so much embarrassed that he made proposals of accommodation upon very moderate terms, viz., that both Pompey and he should disband their armies within three days, renew their former friendship, and return together to Italy. These proposals were sent by Verbullius Rufus, an intimate friend of Pompey, whom Cæsar had twice taken prisoner. Pompey, however, answered that he would not hearken to any terms, lest it should be said that he owed his life and return to Italy to Cæsar's favor. Cæsar again sent one Vatinius to confer with Pompey about a treaty of peace.

Labienus received the proposals; but, while they were conferring together, a party of Pompey's men discharged their darts at Vatinius and his attendants. Some of the guards were wounded, and Vatinius narrowly escaped with his life. In the mean time Cæsar advanced towards Dyrrhachium; but, Pompey unexpectedly appearing, he halted on the other side of the Apsus, where he entrenched himself. Pompey, however, durst not cross the river in Cæsar's sight; so that the two armies continued for some time quiet in their respective camps. Cæsar wrote repeatedly to Marc Antony, who commanded the legions in Italy, to come to his assistance; but received no answer. He then sent Posthumus, one of his lieutenants, with pressing orders to Marc Antony, Gabinius, and Calenus, to bring the troops to him at all events. Gabinius, unwilling to expose all the hopes of his general to the hazards of the sea, marched a great way about by Illyricum. But the Illyrians, who had declared for Pompey, fell unexpectedly upon him and killed him and all his men: Marc Antony and Calenus went by sea, and were in danger from one of Pompey's admirals; but brought their troops safe to shore at Nyphæum, near Apollonia. As soon as it was known that Antony was landed, Pompey marched to prevent his joining Cæsar. But Cæsar, hastening to the relief of his lieutenant, joined him before Pompey came up. Then Pompey retired to an advantageous post near Dyrrhachium, called Asparagium, and there encamped. Cæsar, having thus at length got all his troops together, offered Pompey battle, and kept his army drawn up in sight of the enemy. But, Pompey declining an engagement, he turned towards Dyrrhachium, as if he designed to surprise it. Pompey, following him at some distance, and letting him draw near to the city, encamped on a hill called Petra, which commanded the sea, and whence he could be supplied with provisions from Greece and Asia, while Cæsar was forced to bring corn by land from Epirus. This put Cæsar upon a new design, which was to surround an army far more numerous than his own, and, by shutting them up within a narrow tract of ground, distress them as much for want of forage. Accordingly, he drew a line of circumvallation from the sea quite round Pompey's camp, and kept him so closely blocked up that, though his men were presently supplied with provisions from sea, yet the horses of his army died in great numbers for want of forage. At length, being reduced to the utmost extremity for want of forage, Pompey resolved to force the enemy's lines. By the advice, therefore, of two deserters he embarked his archers, slingers, and light armed infantry, and, marching by land at the head of sixty cohorts, went to attack that part of Cæsar's lines which was next to the sea. He set out from his camp in the dead of the night; and, arriving at the post he designed to force by day-break, he began the attack by sea and land at the same time. The ninth legion, which defended that part of the lines, made a vigorous resistance; but being attacked in the rear by Pompey's men, who came by sea, and landed between Cæsar's two lines, they fled with such precipitation that the succors Marcellinus sent

them could not stop them. The ensign who carried the eagle at the head of the routed legion was mortally wounded; but before he died consigned the eagle to the cavalry, desiring them to deliver it to Cæsar. Pompey's men pursued the fugitives, and made such a slaughter of them that all the centurions of the first cohort were cut off except one. And now Pompey's army broke in like a torrent upon the posts Cæsar had fortified, and were advancing to attack Marcellinus, who guarded a neighbouring fort; but Marc Antony coming very seasonably to his relief with twelve cohorts they retired. Soon after Cæsar arrived with a strong reinforcement and posted himself on the shore, whence he observed an old camp, made within the place where Pompey was enclosed. Upon his quitting it Pompey had taken possession of it, and left a legion to guard it. This post Cæsar resolved to reduce. Accordingly he advanced secretly, at the head of thirty-three cohorts, in two lines; and, arriving at the camp before Pompey could have notice of his march, attacked it with great vigor, forced the first entrenchment, notwithstanding the brave resistance of Titus Pulcio, and penetrated to the second, whither the legion had retired. But here his right wing, in looking for an entrance into the camp, marched along the outside of a trench which Cæsar had formerly carried on from the left angle of his camp, about 400 paces, to a neighbouring river. This trench they mistook for the rampart of the camp; and, being thus led away from their left wing, they were soon after prevented from rejoining it by the arrival of Pompey, who came up at the head of a legion and a large body of horse. Then, that legion which Cæsar had attacked, taking courage, made a brisk sally, drove his men from the first entrenchment which they had seized, and put them in great disorder while they were attempting to pass the ditch. Pompey, falling upon them with his cavalry in flank, completed their defeat; and then, flying to the enemy's right wing, which had passed the trench, and was shut up between that and the ramparts of the old camp, made a most dreadful slaughter of them. This trench was filled with dead bodies; many falling into it in that disorder, and others passing over them and pressing them to death. In this distress Cæsar did all he could to stop the flight of his legionaries but to no purpose: the standard-bearers themselves threw down the Roman eagles when Cæsar endeavoured to stop them, and left them in the hands of the enemy, who on this occasion took thirty-two standards: a disgrace which Cæsar had never suffered before. He was himself in no small danger of falling by the hand of one of his own men, whom he took hold of when flying, bidding him stand and face about; but the man, apprehensive of the danger he was in, drew his sword, and would have killed him, had not one of his guards prevented the blow by cutting off his arm. Cæsar lost on this occasion 960 foot, 400 horse, five tribunes, and thirty-two centurions.

This loss and disgrace greatly mortified Cæsar, but did not discourage him. After he had, by his lenity and eloquent speeches, recovered the spirit of his troops, he decamped, and retired in

good order to Apollonia, where he paid the army and left his sick and wounded. Thence he marched into Macedon, where Scipio Metellus, Pompey's father-in-law, was encamped. He met with great difficulties on his march, the countries through which he passed refusing to supply his army with provisions. On his entering Thessaly he was met by Domitius, one of his lieutenants, whom he had sent with three legions to reduce Epirus. Having got all his forces together, he marched directly to Gomphi, the first town of Thessaly, which had been formerly in his interest, but now declared against him. Whereupon he attacked it with so much vigor that though the garrison was very numerous, and the walls were of an uncommon height, he made himself master of it in a few hours. Thence he marched to Metropolis, another town of Thessaly, which surrendered; as did all the other cities of the country, except Larissa, of which Scipio was master. On the other hand, Pompey, being continually importuned by the senators and officers of his army, left his camp at Dyrrhachium, and followed Cæsar, firmly resolved not to give him battle, but rather to distress him by straitening his quarters, and cutting off his convoys. As he had frequent opportunities of coming to an engagement, but always declined it, his friends and subalterns began to put ill constructions on his dilatoriness. These, with the complaints of his soldiers, made him at length resolve to venture a general action. With this design he marched into a large plain near the cities of Pharsalia and Thebes; which last was also called Philippi, from Philip V. of Macedon. Pompey pitched his camp on the declivity of a steep mountain, in a place altogether inaccessible. He was himself of the opinion that it was better to destroy the enemy by fatigue and want; but his officers forced him to call a council of war, when all to a man were for venturing a general action. The event of this battle was in the highest degree fortunate for Cæsar; who resolved to pursue his advantage and follow Pompey to whatever country he should select. Hearing, therefore, of his being at Amphipolis, he sent off his troops before him, and then embarked on board a little frigate in order to cross the Hellespont; but in the middle of the strait, he fell in with one of Pompey's commanders, at the head of ten ships of war. Cæsar, no way terrified at the superiority of his force, bore up to him and commanded him to submit. The other instantly obeyed, awed by the terror of Cæsar's name, and surrendered himself and his fleet at discretion.

Cæsar continued his voyage to Ephesus, then to Rhodes; and, being informed that Pompey had been there before him, he made no doubt but that he was fled to Egypt; wherefore he set sail for that kingdom, and arrived at Alexandria with about 4000 men. Upon his landing he received accounts of Pompey's miserable end, who had been assassinated by order of the treacherous king; and soon after one of the murderers came with his head and ring. But Cæsar turned away from it with horror, and soon after ordered a magnificent tomb to be built to his memory on the spot where he was murdered; and a tem-

ple near the place to Nemesis. There were at that time two pretenders to the crown of Egypt; Ptolemy, the acknowledged king, and the celebrated Cleopatra his sister, who, by the incestuous custom of the country, was also his wife, and, by their father's will, shared jointly in the succession. However she aimed at governing alone; but, the Roman senate having confirmed her brother's title, she was banished into Syria with Arsinoe her younger sister. Cæsar, however, gave her new hopes of obtaining the kingdom, and sent both for her and her brother to plead their cause before him. Photinus, the young king's guardian, who had long borne the most inveterate hatred both to Cæsar and Cleopatra, disdained this proposal, and backed his refusal by sending an army of 20,000 men to besiege him in Alexandria. Cæsar bravely repulsed the enemy; but, finding the city of too great extent to be defended by so small an army as 4000 men, he retired to the palace, which commanded the harbour, to make a stand. Achilles, who commanded the Egyptians, attacked him there with vigor, and endeavoured to make himself master of the fleet before the palace. On this Cæsar burnt the whole fleet, in spite of every effort to prevent it. He next took the Isle of Pharos, the key to Alexandria, by which he was enabled to receive the supplies sent him from all sides; and in this situation he determined to withstand the united force of all the Egyptians. In the mean time Cleopatra, having heard of the turn in her favor, got herself introduced into his chamber, and her caresses did not fail to fix him in her interest. While Cleopatra was thus employed, her sister Arsinoe was engaged in the camp in pursuing a separate interest. She had, by the assistance of one Ganymede, made a large party in the Egyptian army in her favor; and soon after, having caused Achilles to be murdered, Ganymede took the command in his stead. Ganymede's principal effort in carrying on the siege was to let in the sea upon those canals which supplied the palace with fresh water; but this inconvenience Cæsar remedied by digging a great number of wells. His next endeavour was to prevent the junction of Cæsar's twenty-fourth legion, which he twice attempted in vain. He soon after made himself master of a bridge which joined the Isle of Pharos to the continent, from which post Cæsar resolved to dislodge him. In the heat of action some mariners joined the combatants; but, seized with a panic, instantly fled, and spread a general terror through the army. All Cæsar's endeavours to rally his forces were in vain, the confusion was past remedy, and numbers were drowned or put to the sword in attempting to escape; on which, seeing the irremediable disorder of his troops, he retired to a ship. But he was no sooner on board than such crowds entered at the same time that he was apprehensive of the ship's sinking, and, jumping into the sea, swam 200 paces to the fleet before the palace. The Alexandrians, finding their efforts to take the palace ineffectual, now endeavoured to get their king out of Cæsar's power. For this purpose they made use of their customary arts of dissimulation, professing the utmost desire

for peace, and only wanting the presence of their lawful prince to give a sanction to the treaty. Cæsar, though sensible of their perfidy, gave them their king, as he was under no apprehension from a boy. Ptolemy, however, instead of promoting peace, made every effort to prolong hostilities. In this manner Cæsar was hemmed in for some time; and was only at last relieved from this mortifying situation by Mithridates Pergamenus, one of his faithful partisans; who, collecting a numerous army in Syria, marched into Egypt, and, joining with Cæsar, attacked the camp, and made a great slaughter of the Egyptians. Ptolemy himself, attempting to escape on board a vessel that was sailing down the river, was drowned by the ship's sinking; and Cæsar thus became sole master of all Egypt. He now therefore appointed that Cleopatra, with her younger brother, then an infant, should jointly govern, according to the intention of their father's will; and banished Arsinoe with Ganymede. For a while he also relaxed from his usual personal activity, captivated with the charms of Cleopatra, and passing whole nights in feasts with her. He even proposed to attend her up the Nile into Ethiopia; but the brave veterans who had followed his fortune boldly reprehended his conduct. Thus roused from his lethargy, he left Cleopatra, by whom he had a son, afterwards named Cæsario, to oppose Pharnaces king of Pontus. Here he was attended with the greatest success; and, having settled affairs in this part of the empire, embarked for Italy, where he arrived sooner than his enemies expected. He had been, during his absence, created consul for five years, dictator for one year, and tribune of the people for life. But Antony, who governed in Rome for him, had filled the city with riot and debauchery. By his moderation and humanity Cæsar soon restored tranquillity, and then prepared to march into Africa, where Pompey's party had rallied under Scipio and Cato, assisted by Juba king of Mauritania. But the vigor of his proceedings was near being retarded by a mutiny in his own army. Those veteran legions, who had hitherto conquered all that came before them, began to murmur at not having received the reward which they had expected, and now insisted upon their discharge. Cæsar however quelled the mutiny; and then, with his usual rapidity, landed with a party in Africa, the rest of the army following soon after. After many skirmishes, he invested Tapsus, supposing that Scipio would attempt its relief; which accordingly happened. Scipio, joining with Juba, advanced with his army, and, encamping near Cæsar, they came to a general engagement. Cæsar's success was as usual; the enemy received a complete and total overthrow, with little loss on his side. Juba, and Petreius his general, killed each other in despair; Scipio, attempting to escape by sea into Spain, fell among the enemy, and was slain; so that, of all the generals of that undone party, Cato alone was now remaining. This extraordinary man, having retired to Africa after the battle of Pharsalia, had led the wretched remains of that army through burning deserts and tracts infected with serpents, and was now in Utica, which he had

been left to defend. Still, however, in love with even the show of a Roman government, he had formed the principal citizens into a senate, and conceived a resolution of holding out the town. He accordingly assembled his senators upon this occasion, and exhorted them to stand a siege; but, finding his admonitions ineffectual, stabbed himself with his sword. See CATO.

Upon Cato's death, the war in Africa being completed, Cæsar returned in triumph to Rome, and astonished the citizens at the magnificence of it, and at the number of the countries which he had subdued. It lasted four days; the first was for Gaul, the second for Egypt, the third for his victories in Asia, and the fourth for that over Juba in Africa. To every one of his soldiers he gave a sum equivalent to about £150 of our money, double that sum to the centurions, and four times as much to the superior officers. The citizens also shared his bounty; to every one of whom he distributed ten bushels of corn, ten pounds of oil, and a sum of money equal to about two pounds sterling. After this he entertained the people at about 20,000 tables, treated them with the combats of gladiators, and filled Rome with a concourse of spectators from every part of the world. The people now seemed eager only to find out new modes of homage and adulation for their new master. He was created *magister morum*, or master of the morals of the people; received the titles of emperor and father of his country; his person was declared sacred; and, in short, upon him alone were devolved for life all the great dignities of the state. It must be owned that no sovereign could make a better use of his power. He began by repressing vice and encouraging virtue; he communicated the power of judicature to the senators and the knights alone, and by many sumptuary laws restrained the scandalous luxuries of the rich. He proposed rewards to all who had many children; and took the most prudent methods of re-peopling the city. Having thus restored prosperity to Rome, he once more found himself under a necessity of going into Spain, to oppose an army which had been raised there under the two sons of Pompey, and Labienus his former general. He proceeded in this expedition with his usual celerity, and arrived before the enemy thought he had left Rome. Cneius and Sextus, Pompey's sons, profiting by their unhappy father's example, resolved to protract the war; so that the first operations of the two armies were spent in sieges and fruitless attempts. At length Cæsar, after taking many cities from the enemy, and pursuing young Pompey with unwearied perseverance, compelled him to come to a battle upon the plains of Munda. After a most obstinate engagement, Cæsar gained a complete victory; and, having now subdued all his enemies, returned to Rome for the last time to receive new dignities and honors. Still, however, he showed great moderation in the use of his power; he left the consuls to be named by the people; he enlarged the number of senators; he pardoned all who had been in arms against him; but deprived them of the power of resistance. He even set up once more the statues of Pompey. The rest of this extraordinary man's life was certainly de-



voted to the advantage of the state. He adorned the city with magnificent buildings; he rebuilt Carthage and Corinth, sending colonies to both; he undertook to level several mountains in Italy, to drain the Pontine marshes, and designed to cut through the Isthmus of the Peloponnesus. Thus he formed mighty projects and designs beyond the limits of the longest life; but the greatest of all was his intended expedition against the Parthians, by which he designed to revenge the death of Crassus; then to pass through Hyrcania, and enter Scythia along the banks of the Caspian Sea; thence to open himself a way through the immeasurable forests of Germany in Gaul, and so return to Rome. These were the plans of this great man; but the jealousy of a few individuals soon put an end to them. The senate, with an adulation which marked the degeneracy of the times, continued to load Cæsar with fresh honors, and he continued with avidity to receive them. They called the month Quintilis July after him; to which indeed he was entitled by his reform of the calendar; they stamped money with his image; they ordered his statue to be set up in all the cities of the empire; instituted public sacrifices on his birth-day; and talked, even in his life-time, of enrolling him in the number of their gods. Antony, at one of their public festivals, foolishly ventured to offer him a diadem; but he repeatedly refused it, and received at every refusal loud acclamations from the people. One day, when the senate gave him some particular order, he neglected to rise from his seat; and from that moment it began to be rumored that he intended to make himself king; for, though in fact he already possessed supreme power, the people could not bear his assuming the title. Whether he ever really designed to wear that empty honor must now for ever remain a secret; certain it is that the unsuspecting openness of his conduct marked something like a confidence in his own innocence. When informed by those about him of the jealousies of many who envied him, he said that he had rather die once by treason than live continually in the apprehension of it; and disbanded his company of Spanish guards. Yet a deep-laid conspiracy was formed against him, composed of no less than sixty senators. At the head of this conspiracy was Brutus, whose life Cæsar had spared after the battle of Pharsalia, and Cassius, who had been pardoned soon after, both prætors for the year. Brutus gloried in being descended from that Brutus who first gave liberty to Rome; and, from a wish to follow his example, broke all the ties of gratitude, and joined in a conspiracy to destroy his benefactor: Cassius was impetuous and proud, and hated Cæsar more than his cause. He had often sought an opportunity of assassination, rather from private than public motives. The conspirators, to give a color of justice to their proceedings, remitted the execution of their design to the ices of March, the day on which it was reported that Cæsar was to be offered the crown. The augurs had foretold that this day would be fatal to him; and the night preceding he heard his wife Calphurnia lamenting in her sleep; and, being awakened, she confessed to

him that she dreamed of his being assassinated in her arms. These omens had almost changed his intention of going to the senate; but one of the conspirators, coming in, prevailed upon him to do so, telling him of the reproach which would attend his staying at home till his wife had lucky dreams. As he went to the senate, a slave, who hastened to him with information of the conspiracy, attempted to come near him, but could not for the crowd. Artemidorus, a Greek philosopher, who had discovered the whole plot, delivered him a memorial containing his information; but Cæsar gave it to one of his secretaries without reading it. As soon as he had taken his place in the senate, the conspirators came near, under a pretence of saluting him; and Cimber approached in a suppliant posture, to sue for his brother's pardon, who was banished. All the conspirators seconded him, and Cimber, apparently to apply with the greater submission, took hold of the bottom of his robe, so as to prevent his rising. This was the signal. Casca, who was behind, stabbed him slightly in the shoulder. Cæsar instantly turned round, and with the style of his tablet wounded him in the arm. But, the rest of the conspirators enclosing him round, he received a second stab from an unknown hand in the breast, while Cassius wounded him in the face. He still defended himself vigorously, rushing among them, and throwing down such as opposed him, till he saw Brutus among the conspirators, who, coming up, struck his dagger in his thigh. From that moment Cæsar thought no more of defending himself; but, looking upon this assailant steadily, cried out, 'And you, too, my son Brutus?' Then covering his head, and spreading his robe before him to fall with decency, he sunk down at the base of Pompey's statue, after receiving twenty-three wounds, in the fifty-sixth year of his age, and fourth of his dictatorship.

As soon as the conspirators had despatched Cæsar, they addressed the senate to vindicate their motives, and to excite them to join in procuring their country's freedom; but all the senators who were not accomplices fled. The people also, being alarmed, ran tumultuously through the city; some actuated by their fears, and more by a desire of plunder. In this confusion, the conspirators retired to the capitol, and guarded its accesses by a body of gladiators. It was in vain they alleged they only struck for freedom, and that they killed a tyrant who usurped the rights of mankind; the people, accustomed to luxury and ease, little regarded their professions. The friends of the late dictator now found that this was the time for gratifying their ambition under the veil of justice. Antony, who was a lieutenant under Cæsar, was a man of moderate abilities and of excessive vices; ambitious of power, but well skilled in war. He was consul for that year; and resolved with Lepidus to seize the sovereign power. Lepidus therefore took possession of the forum with a band of soldiers; and Antony, being consul, was permitted to command. They first possessed themselves of all Cæsar's papers and money; next they convened the senate, to determine whether Cæsar had been a legal magistrate

or a usurper, and whether those who killed him merited reward or punishment. There were many of those who had received their promotions from Cæsar, and had acquired large fortunes in consequence of his appointments; to vote him a usurper therefore would have endangered their property; and yet to vote him innocent might endanger the state. In this dilemma they tried to reconcile extremes; they approved all the acts of Cæsar, but granted a general pardon to the conspirators. This decree did not satisfy Antony, as it granted security to a number of men who were the avowed enemies of tyranny, and who would be foremost in opposing his schemes. As therefore the senate had ratified all Cæsar's acts, without distinction, he formed a scheme upon this of making him rule when dead. Being possessed of Cæsar's books, he prevailed upon his secretary to insert whatever he thought proper. By these means, great sums of money, which Cæsar never would have bestowed, were ordered to be distributed among the people; and every man who was averse to republican principles was sure of finding a gratuity. He then demanded that Cæsar's funeral obsequies should be performed; which the senate could not decently forbid, as they had never declared him a tyrant. Accordingly the body was brought forth into the forum with the utmost solemnity; and Antony began to excite the passions of the people. He first read Cæsar's will, in which he had left Octavius, his sister's grandson, his heir, permitting him to take the name of Cæsar; and three parts of his private fortune Brutus was to inherit in case of his death. The Roman people were left the gardens which he had on the other side the Tiber; and every citizen was to receive 300 sesterces. This last bequest greatly increased the people's affection for Cæsar; they considered him as a father, who, after doing them the greatest good while living; thought of benefiting them after his death. As Antony continued reading, the multitude were moved, and lamentations were heard from every quarter. Antony now began to address the assembly in a more pathetic strain; he presented before them Cæsar's bloody robe, and, as he unfolded it, took care they should observe the number of stabs in it; he then displayed an image of the body of Cæsar, all covered with wounds. The people could now no longer contain their indignation; they unanimously cried out for revenge; and the multitude ran with flaming brands from the pile to set fire to the conspirator's houses. They, however, being well guarded, repulsed the multitude; but, perceiving their rage, they thought it safest to retire from the city. Divine honors were then granted to the fallen dictator; and an altar was erected on the place where his body was burnt, where afterwards was erected a column inscribed, TO THE FATHER OF HIS COUNTRY. In the mean time Antony, having gained the people by his zeal in Cæsar's cause, next endeavoured to bring over the senate, by a seeming concern for the freedom of the state. He therefore proposed to recall Sextus, Pompey's only remaining son, who had concealed himself in Spain, and to grant him the

command of all the fleets of the empire. His next step was the quelling a sedition of the people, who rose to revenge the death of Cæsar, and putting their leader Amathus to death, who pretended to be the son of Marius. He after this pretended to dread the resentment of the multitude, and demanded a guard. The senate granted it; and, under this pretext, he drew round him a body of 6000 resolute men, attached to his interests. Thus he continued every day making rapid strides to absolute power; all the authority of government was lodged in his hands and those of his two brothers, who shared among them the consular tribunitian and prætorian power. His vows to revenge Cæsar's death seemed postponed or forgotten; and his only aim was to confirm himself in that power which he had thus artfully acquired. But an obstacle to his ambition soon arose in Octavius, or Octavianus Cæsar, the grand nephew and adopted son of Cæsar, who was at Apollonia when his kinsman was slain. He was then about eighteen years old, and had been sent to that city to improve himself in Grecian literature. Upon the news of Cæsar's death, notwithstanding the earnest dissuasions of his friends, he returned to Rome to claim the inheritance, and revenge the death of his uncle. But Antony, whose projects were only to aggrandise himself, gave him but a cold reception, and, instead of granting him the fortune left him by Cæsar's will, delayed the payment of it upon various pretences. Octavianus, instead of abating his claims, sold his own patrimonial estate to pay such legacies as Cæsar had left, and particularly that to the people. By these means he gained a degree of popularity, which his enemies vainly labored to diminish. The army near Rome, who had long wished to see the conspirators punished, began to turn from Antony to his rival, whom they saw more sincerely bent on gratifying their desires. Antony having procured also the government of Hiiber Gaul from the people, two of the legions that he had brought home from his former government of Macedonia went over to Octavianus. This produced, as usual, interviews, complaints, recriminations, and pretended reconciliations, which only widened the difference; so that at length both sides prepared for war. Thus the state was divided into three distinct factions; that of Octavianus, who aimed at procuring Cæsar's inheritance and revenging his death; that of Antony, whose sole view was to obtain absolute power; and that of the conspirators, who endeavoured to restore the republic. Antony, being raised by the people to his new government of Cisalpine Gaul, contrary to the inclinations of the senate, resolved to enter upon that province immediately, and oppose Brutus, who commanded a small body of troops there, while his army was yet entire. He accordingly left Rome, and, marching thither, commanded Brutus to depart. Brutus, being unable to oppose him, retired with his forces; but, being pursued by Antony, he was at last besieged in the city of Mutina, of which he sent word to the senate. In the meanwhile, Octavianus, who by this time had raised a body of 10,000 men, returned to Rome; and being resolved, before

he attempted to take vengeance on the conspirators, if possible to diminish the power of Antony, began by bringing over the senate to second his designs. In this he succeeded by the credit of Cicero, who had long hated Antony. Accordingly, by his eloquence, a decree was passed, ordering Antony to raise the siege of Mutina, to evacuate Cisalpine Gaul, and to wait the further orders of the senate upon the banks of the Rubicon. Antony treated the order with contempt; and, instead of obeying, began to show his displeasure. On this the senate declared him an enemy to the state, and sent Octavianus, with the army he had raised, to curb his insolence. The consuls, Hirtius and Pansa, joined also their forces; and, thus combined, they marched at the head of a numerous army, against Antony into Cisalpine Gaul. After one or two ineffectual conflicts, both armies came to a general engagement; in which Antony was defeated, and compelled to fly to Lepidus, who commanded a body of forces in Further Gaul. This victory, however, which promised the senate so much success, produced effects very different from their expectations. The two consuls were mortally wounded; but Pansa, previous to his death, called Octavianus to his bed-side, and advised him to join with Antony, telling him that the senate only desired to depress both, by opposing them to each other. The advice of the dying consul sunk deep on his spirits; so that from that time he only sought a pretext to break with them. Their giving the command of a part of his army to Decimus Brutus, and their denying him a triumph soon after, served to alienate his mind entirely from the senate, and made him resolve to join Antony and Lepidus. He was willing, however, to try the senate thoroughly, before he came to an open rupture; wherefore he sent to demand the consulship, which was refused. He then privately sent to sound the inclinations of Antony and Lepidus, concerning a junction of forces, and found them as eager to assist as the senate was to oppose him. Antony was in fact the general of both armies, and Lepidus was only nominally so, his soldiers refusing to obey him upon the approach of the former. Wherefore, upon being assured of the assistance of Octavianus upon their arrival in Italy, they soon crossed the Alps with an army of seventeen legions, breathing revenge against all who had opposed their designs. The senate now began, too late, to perceive their error in disobliging Octavianus; and therefore gave him the consulship which they had so lately refused; and, to prevent his joining with Antony, flattered him with new honors, giving him a power superior to all law. The first use Octavianus made of his new authority was to procure a law for the condemnation of Brutus and Cassius; after which he joined his forces with those of Antony and Lepidus. The meeting of these three usurpers of their country's freedom was near Mutina, upon a little island of the river Panarus. Their mutual suspicions were the cause of their meeting in this place. Lepidus first entered, and, finding all things safe, made the signal for the other two to approach. Their conference lasted three days; and the result of

it was, that the supreme authority should be lodged in their hands, under the title of the triumvirate, for five years; that Antony should have Gaul, Lepidus Spain, and Octavianus Africa and the Mediterranean Islands. As for Italy, and the eastern provinces, they were to remain in common until their general enemy was entirely subdued. But the last article of their union was a dreadful one. It was agreed that all their enemies should be destroyed; of which each presented a list. In these were comprised not only the enemies but the friends of the triumvirate, since the partisans of the one were often found among the opposers of the others. Thus Lepidus gave up his brother Paulus to the vengeance of his colleague; Antony permitted the proscription of his uncle Lucius; and Octavianus delivered up the great Cicero. The most sacred rights of nature were violated; 300 senators, and above 2000 knights, were included in this terrible proscription; their fortunes were confiscated, and their murderers enriched with the spoil. Rome soon felt the effects of this infernal union, and the horrid cruelties of Marius and Sylla were renewed. As many as could escape the cruelty of the triumvirs, fled into Macedonia to Brutus, or found refuge with young Pompey, who was now in Sicily, and covered the Mediterranean with his numerous navy. Their cruelties were not aimed at the men alone; but the softer sex were also marked as objects of avarice or resentment. They made out a list of 1400 women of the richest in the city, who were ordered to give in an account of their fortunes to be taxed. But this was so firmly opposed by Hortensia, that they were content to tax only 400. However, they made up the deficiency by extending the tax upon men; nearly 100,000, as well citizens as strangers, were compelled to furnish supplies to the subversion of freedom. At last, both the avarice and vengeance of the triumviri seemed fully satisfied, and they went into the senate to declare that the proscription was at an end; and thus having deluged the city with blood, Octavianus and Antony, leaving Lepidus to defend Rome in their absence, marched with their forces to oppose the conspirators, who were now at the head of a formidable army in Asia.

Brutus and Cassius, the principal conspirators upon the death of Caesar, being compelled to quit Rome, went into Greece, where they persuaded the Roman students at Athens to declare in the cause of freedom; then, parting, the former raised a powerful army in Macedonia and the adjacent countries, while the latter went into Syria, where he became master of twelve legions, and reduced his opponent Dolabella to such straits that he killed himself. Both parties soon after joining, at Smyrna, the sight of such a formidable force began to revive the declining spirits of the party, and to unite the two generals still more closely. The Rhodians and Lycians having refused their usual contributions, the conspirators made their reduction their first business. The Lycians, rather than submit, burned themselves alive in Xanthus; the humanity of Brutus could save only 150 from the flames. As Antony and Octavianus were now advanced

into Macedonia, they soon after passed over into Thrace, and advanced to Philippi, near which the forces of the triumvirs were posted. A battle soon ensued, in which the republicans were defeated, and Cassius killed. Previous to this battle Brutus is said to have seen a spectre, which warned him of the issue. Brutus, when he became sole general, assembled the dispersed troops of Cassius, and animated them with fresh hopes of victory. As they had lost all they possessed, by the plundering of their camp, he promised them 2000 denarii each man to make up their losses. Still, however, he had not confidence to face the adversary, who offered him battle next day. His aim was to starve his enemies, who were in extreme want of provisions, their fleet having been lately defeated. But his single opinion was over-ruled by the rest of his army, and he was, after a respite of twenty days, obliged to comply with their solicitations to try the fate of the battle. Fortune again declared against him; and the two triumviri expressly ordered by no means to suffer the general to get off, lest he should renew the war. His friend Lucilius giving himself as Brutus, he effected his escape; but however, finding all hopes of retrieving his affairs lost, he slew himself the same night.

After Brutus's death the triumviri acted as sovereigns, and divided the Roman dominions among them. However, though there were apparently three who thus participated the power, only two were actually possessed of it. Lepidus was admitted merely to curb the jealousy of Antony and Octavianus, and possessed neither interest in the army nor authority among the people. Their first care was to punish those whom they had formerly marked for vengeance. The head of Brutus was sent to Rome to be thrown at the foot of Cæsar's statue. His ashes, however, were sent to his wife Porcia, Cato's daughter, who afterwards killed herself by swallowing burning coals. Of all those who had a hand in Cæsar's death, not one died a natural death. The power of the triumviri being thus established, upon the ruins of the commonwealth, Antony went into Greece. Thence he passed over into Asia, where all the monarchs of the east, who acknowledged the Roman power, came to pay him obedience. Among other sovereigns Cleopatra came to him at Tarsus, and he was so captivated by her charms that he returned to Egypt with her, and gave himself up to love. While he thus remained idle, Octavianus, who undertook to lead back the veteran troops and settle them in Italy, was assiduously employed in providing for their subsistence. He had promised them lands at home, as a recompense for their past services; but they could not receive new grants without turning out the former inhabitants. In consequence of this, multitudes of women, with children in their arms, whose tender years and innocence excited universal compassion, daily filled the temples and the streets with their distresses. Numbers of husbandmen and shepherds came to deprecate the conqueror's intention, or to obtain a habitation in some other part of the world: amongst this number was Virgil the poet, who in an humble manner

begged permission to retain his patrimonial farm. Virgil obtained his request, but the rest of his countrymen of Mantua and Cremona were turned out without mercy. Italy and Rome now felt the most extreme miseries; the insolent soldiers plundered at will; while Sextus Pompey, being master of the sea, cut off all foreign communication, and prevented the people's receiving their usual supplies of corn. To these mischiefs were added the commencement of another civil war. Fulvia, the wife of Antony, who had been left at Rome, had felt for some time all the rage of jealousy, and resolved to try every method of bringing back her husband from the arms of Cleopatra. She considered a breach with Octavianus as the only probable means of rousing him from his lethargy; and accordingly, with the assistance of Lucius Antonius, her brother-in-law, who was then consul, and entirely devoted to her interest, she began to sow the seeds of dissension. The pretext was, that Antony should have a share in the distribution of lands as well as Octavianus. To negotiations succeeded war, and Octavianus, being victorious, generously pardoned the conquered, but obliged Fulvia to quit Italy. Antony, learning what was passing, resolved to oppose Octavianus without delay. He accordingly sailed at the head of a considerable fleet from Alexandria to Tyre, thence to Cyprus and Rhodes, and had an interview with Fulvia at Athens. He blamed her for occasioning the late disorders, expressed the utmost contempt for her person, and, leaving her upon her death-bed at Sicyon, hastened into Italy to fight Octavianus. They met at Brundisium. Antony's forces were numerous, but mostly newly raised; but he was assisted by Sextus Pompeius, who was daily coming into power. Octavianus was at the head of those veterans who had always been irresistible, but who seemed not disposed to fight against Antony, their former general. A negotiation was therefore proposed, and a reconciliation effected. All offences were mutually forgiven; and a marriage was concluded between Antony and Octavia, the sister of Octavianus. A new division of the Roman empire was made between them; Octavianus was to have the command of the west, Antony of the east, while Lepidus was to have the provinces in Africa. As for Sextus Pompeius, he was permitted to retain all the islands he had already possessed; together with Peloponnesus: he was also granted the privilege of demanding the consulship in his absence, and of discharging that office by any of his friends. It was also stipulated to leave the sea open, and pay the people what corn was due out of Sicily. Thus a general peace was concluded. This calm was continued for some time: Antony led his forces against the Parthians, over whom his lieutenant Ventidius had gained great advantages, while Octavianus drew the greatest part of his army into Gaul, where there were some disturbances; and Pompey went to secure his newly ceded province. It was on this quarter that fresh motives were given for renewing the war. Antony, who was obliged by treaty to quit Peloponnesus, refused to evacuate it till Pompey had satisfied him for such debts as were due to him from the inhabitants. This Pompey

refused; but immediately fitted out a new fleet, and renewed his former enterprises, by cutting off such corn and provisions as were consigned to Italy. Thus the grievances of the poor were again renewed; and the people, instead of three tyrants, were now oppressed by four. In this exigence, Octavianus, who had long meditated diminishing the number, resolved to begin by getting rid of Pompey. He was master of two fleets; one of which he had caused to be built at Ravenna; and another which Menodorus, who revolted from Pompey, brought to his aid. His first attempt was to invade Sicily; but being overpowered in his passage by Pompey, and his fleet afterwards shattered in a storm, he was obliged to defer his design till the next year. During this interval he was reinforced by a fleet of 120 ships, given him by Antony, with which he resolved once more to invade Sicily. He was again disabled and shattered by a storm: which so raised the vanity of Pompey that he began to style himself the son of Neptune. However, Octavianus having refitted his navy and recruited his forces, he gave the command of both to Agrippa, his faithful friend, who proved himself worthy of the trust. He began his operations by a victory over Pompey; and, though he was shortly after worsted, he soon after gave his adversary a complete and final overthrow. Pompey resolved to fly to Antony, from whom he expected refuge, as he had formerly obliged that triumvir by protecting his mother. However he tried once more, at the head of a small body of men, to make himself independent, and surprised Antony's officers who had been sent to accept of his submissions. But he was at last abandoned by his soldiers, and delivered up to Titus, Antony's lieutenant, who caused him to be slain. The death of this general removed one very powerful obstacle to the ambition of Octavianus, and he resolved to get rid of the rest of his associates. An offence was soon furnished by Lepidus, that served as a pretext for depriving him of his share in the triumvirate. Being at the head of twenty-two legions, with a strong body of cavalry, he supposed that his power was more than equivalent to the popularity of Octavianus. He therefore resolved to add Sicily to his province; pretending a right, as having first invaded it. His colleague having previously expostulated without success, and knowing that his secret intrigues and largesses had entirely attached the army to himself, went alone to the camp of Lepidus, deprived him of all his authority, and banished him to Circæum. There remained now but one obstacle to his ambition, viz. Antony, whom he resolved to remove, and began to render his character as contemptible as he could at Rome. In fact Antony's own conduct contributed greatly to promote the object of his rival. He had marched against the Parthians with a prodigious army; but was forced to return with the loss of the fourth part of his forces, and all his baggage. This greatly diminished his reputation; but his making a triumphal entry into Alexandria, soon after, entirely disgusted the citizens of Rome. However Antony, totally disregarding the business of the state, spent whole

months in the company of Cleopatra, who studied every art to increase his passion, and retain him in her chains. Not contented with sharing in her company all the delights which Egypt could afford, Antony was resolved to enlarge his sphere of luxury, by granting her several of those kingdoms which belonged to the Roman empire. He gave her all Phœnicia, Cœlo-Syria, and Cyprus; with a great part of Cilicia, Arabia, and Judea; gifts which he had no right to bestow, but which he pretended to grant in imitation of Hercules. This complication of vice and folly at length exasperated the Romans; and Octavianus took care to exaggerate all his faults. At length he resolved to send Octavia to Antony, as if with a view of reclaiming her husband, but in fact to furnish a sufficient pretext of declaring war against him. Accordingly, Antony ordered her to return without seeing her. Octavianus had now a sufficient pretext for declaring war; and informed the senate of his intention. But he deferred it for a while, being then employed in quelling an insurrection of the Illyrians. The following year was taken up in preparations against Antony. Antony ordered Canidius with his army to march into Europe; while he and Cleopatra followed to Samos, to prepare for carrying on the war with vigor. The kings who attended him endeavoured to gain his favor more by their entertainments than their warlike preparations; and the provinces strove rather to please him by sacrificing to his divinity, than by their alacrity in his defence. In short, his best friends now began to forsake him. His delay at Samos, and afterwards at Athens, where he carried Cleopatra to receive new honors, was extremely favorable to the arms of Octavianus; who was at first scarcely in a situation to oppose him, had he gone into Italy; but he soon found time to put himself in a condition for carrying on the war. All Antony's followers were invited over to join him with great promises of rewards. Their armies were suitable to the empire they contended for. The one was followed by all the forces of the east; the other by the strength of the west. Antony's force composed a body of 100,000 foot and 12,000 horse; his fleet amounted to 500 ships of war. The army of Octavianus mustered only 80,000 foot, but equalled his adversary's in number of cavalry; his fleet was but half as numerous as Antony's; however his ships were better built, and manned with better soldiers. The great decisive engagement, which was a naval one, was fought near Actium, a city of Epirus, at the entrance of the gulph of Ambracia. Antony ranged his ships before the mouth of the gulph; and Octavianus drew up his in opposition. The two land armies on opposite sides of the gulph, were drawn up only as spectators. The battle began on both sides with great ardor; nor was there any advantage on either side till of a sudden Cleopatra fled from the engagement attended by sixty sail; what increased the general amazement was to behold Antony himself following soon after. Yet the engagement continued with great obstinacy till 5 P. M., when Antony's forces submitted. The land forces soon after followed the example of the navy; and all yielded without

striking a blow the fourth day after the battle.

When Cleopatra fled Antony pursued her in a five-oared galley; and, coming along side of her ship, entered without seeing or being seen by her. She was in the stern, and he went to the prow, where he remained for some time silent, holding his head between his hands. In this manner he continued three whole days; during which, either through indignation or shame, he neither saw nor spoke to the queen. At last, when they arrived at the promontory of Tenarus, Cleopatra's female attendants reconciled them, and every thing went on as before. Still, however, he had the consolation to suppose his army continued faithful; and accordingly despatched orders to his lieutenant Canidius to conduct it into Asia. When however he arrived in Africa, he was informed of their submission to his rival. This account so transported him with rage that he was hardly prevented from killing himself; at length, at the entreaty of his friends, he returned to Alexandria. Cleopatra, however, seemed to retain that fortitude in her misfortunes which had abandoned her admirer. Having amassed considerable riches, by confiscation and other acts of violence, she formed a very singular project, to convey her whole fleet over the isthmus of Suez into the Red Sea, and thus save herself with all her treasures in another region beyond the reach of Rome. Some of her vessels were actually transported thither, pursuant to her orders; but the Arabians having burnt them, and Antony dissuading her from the design, she abandoned it for the more improbable scheme of defending Egypt. She made all preparation for war; at least hoping thereby to obtain better terms from Octavianus. In fact, she had always loved Antony's fortunes rather than his person; and if she could have fallen upon any method of saving herself, though even at his expense, she would have embraced it. She even still had some hopes from the power of her charms, though she was almost forty; and was desirous of trying upon Octavianus those arts which had been so successful with the greatest men of Rome. Thus in the three embassies which were sent from Antony to his rival in Asia, the queen had always her secret agents, charged with particular proposals in her name. Antony desired only that his life might be spared, and to pass the rest of his days in obscurity. To these proposals Octavianus made no reply. Cleopatra sent him also public proposals in favor of her children; but at the same time privately resigned him her crown, with all the ensigns of royalty. To the queen's public proposal no answer was given; to her private offer he replied, by giving her assurances of his favor in case she sent away Antony or put him to death. When these negotiations came to the knowledge of Antony, his jealousy and rage were heightened to the utmost. He built a solitary house upon a mole in the sea; where he passed his time, shunning all commerce with mankind, and professing to imitate Timon the man-hater. But his furious jealousy drove him even from this retreat; for hearing that Cleopatra had many secret conferences with one Thyrus, an emissary from Octavianus, he seized upon him, and, having ordered him to be cruelly

scourged, sent him back to his patron. Meanwhile, the war was carried vigorously forward, and Egypt was once more the theatre of the contending armies of Rome. Gallus, the lieutenant of Octavianus, took Paretonium, which opened the whole country to his incursions. Octavianus himself was in the mean time advancing with another army before Pelusium, the governor of which gave him possession of the place. Antony, upon his arrival, sallied out to oppose him, fighting with great desperation, and putting the enemy's cavalry to flight. This slight advantage revived his declining hopes, and he reentered Alexandria in triumph. Then, going to the palace, he embraced Cleopatra, and presented her a soldier who had distinguished himself in the late engagement. The queen rewarded him very magnificently; presenting him with a head-piece and breast-plate of gold. With these, however, the soldier went off the next night to the other army. Antony could not bear this defection; he resolved, therefore, to make a bold expiring effort by sea and land, but previously offered to fight his adversary in single combat. Octavianus coolly replied that Antony had ways enough to die besides single combat. At day-break Antony posted the few troops he had remaining upon a rising ground near the city: whence he sent orders to his galleys to engage the enemy. There he waited to be a spectator of the combat; and, at first, he saw them advance in good order; but his approbation was turned into rage, when he saw his ships only saluting those of Octavianus, and both fleets uniting, and falling back into the harbour. At the same time his cavalry deserted him. He tried, however, to lead on his infantry; which were soon vanquished, and himself compelled to return into the town. His anger was now ungovernable; he could not help crying out aloud as he passed that he was betrayed by Cleopatra, and delivered by her to those who, for her sake alone, were his enemies. In these suspicions he was not deceived; for it was by secret orders from the queen that the fleet had passed over to the enemy. Cleopatra had for a long while dreaded the effects of Antony's jealousy; and had some time before prepared a method of obviating any sudden sallies it might produce. Near the temple of Isis she had erected a building, which was seemingly designed for a sepulchre. Hither she removed all her treasure and most valuable effects, covering them over with torches, faggots, and other combustible matter. This sepulchre she designed to answer a double purpose; as well to screen her from the sudden resentments of Antony, as to make Octavianus believe that she would burn all her treasures in case he refused her proper terms of capitulation. Here, therefore, she retired from Antony's fury; shutting the gates, which were fortified with bolts and bars of iron: but in the mean time gave orders to spread a report of her death. This news, which soon reached Antony, recalled all his former love. He now lamented her death with the same violence he had but a few minutes before seemed to desire it; and called one of his freed men, named Eros, whom he had engaged by oath to kill him whenever fortune should

refused; but immediately fitted out a new fleet, and renewed his former enterprises, by cutting off such corn and provisions as were consigned to Italy. Thus the grievances of the poor were again renewed; and the people, instead of three tyrants, were now oppressed by four. In this exigence, Octavianus, who had long meditated diminishing the number, resolved to begin by getting rid of Pompey. He was master of two fleets; one of which he had caused to be built at Ravenna; and another which Menodorus, who revolted from Pompey, brought to his aid. His first attempt was to invade Sicily; but being overpowered in his passage by Pompey, and his fleet afterwards shattered in a storm, he was obliged to defer his design till the next year. During this interval he was reinforced by a fleet of 120 ships, given him by Antony, with which he resolved once more to invade Sicily. He was again disabled and shattered by a storm: which so raised the vanity of Pompey that he began to style himself the son of Neptune. However, Octavianus having reititted his navy and recruited his forces, he gave the command of both to Agrippa, his faithful friend, who proved himself worthy of the trust. He began his operations by a victory over Pompey; and, though he was shortly after worsted, he soon after gave his adversary a complete and final overthrow. Pompey resolved to fly to Antony, from whom he expected refuge, as he had formerly obliged that triumvir by protecting his mother. However he tried once more, at the head of a small body of men, to make himself independent, and surprised Antony's officers who had been sent to accept of his submissions. But he was at last abandoned by his soldiers, and delivered up to Titus, Antony's lieutenant, who caused him to be slain. The death of this general removed one very powerful obstacle to the ambition of Octavianus, and he resolved to get rid of the rest of his associates. An offence was soon furnished by Lepidus, that served as a pretext for depriving him of his share in the triumvirate. Being at the head of twenty-two legions, with a strong body of cavalry, he supposed that his power was more than equivalent to the popularity of Octavianus. He therefore resolved to add Sicily to his province; pretending a right, as having first invaded it. His colleague having previously expostulated without success, and knowing that his secret intrigues and largesses had entirely attached the army to himself, went alone to the camp of Lepidus, deprived him of all his authority, and banished him to Circæum. There remained now but one obstacle to his ambition, viz. Antony, whom he resolved to remove, and began to render his character as contemptible as he could at Rome. In fact Antony's own conduct contributed greatly to promote the object of his rival. He had marched against the Parthians with a prodigious army; but was forced to return with the loss of the fourth part of his forces, and all his baggage. This greatly diminished his reputation; but his making a triumphal entry into Alexandria, soon after, entirely disgusted the citizens of Rome. However Antony, totally disregarding the business of the state, spent whole

months in the company of Cleopatra, who studied every art to increase his passion, and retain him in her chains. Not contented with sharing in her company all the delights which Egypt could afford, Antony was resolved to enlarge his sphere of luxury, by granting her several of those kingdoms which belonged to the Roman empire. He gave her all Phœnicia, Cœlo-Syria, and Cyprus; with a great part of Cilicia, Arabia, and Judea; gifts which he had no right to bestow, but which he pretended to grant in imitation of Hercules. This complication of vice and folly at length exasperated the Romans; and Octavianus took care to exaggerate all his faults. At length he resolved to send Octavia to Antony, as if with a view of reclaiming her husband, but in fact to furnish a sufficient pretext of declaring war against him. Accordingly, Antony ordered her to return without seeing her. Octavianus had now a sufficient pretext for declaring war; and informed the senate of his intention. But he deferred it for a while, being then employed in quelling an insurrection of the Illyrians. The following year was taken up in preparations against Antony. Antony ordered Canidius with his army to march into Europe; while he and Cleopatra followed to Samos, to prepare for carrying on the war with vigor. The kings who attended him endeavoured to gain his favor more by their entertainments than their warlike preparations; and the provinces strove rather to please him by sacrificing to his divinity, than by their alacrity in his defence. In short, his best friends now began to forsake him. His delay at Samos, and afterwards at Athens, where he carried Cleopatra to receive new honors, was extremely favorable to the arms of Octavianus; who was at first scarcely in a situation to oppose him, had he gone into Italy; but he soon found time to put himself in a condition for carrying on the war. All Antony's followers were invited over to join him with great promises of rewards. Their armies were suitable to the empire they contended for. The one was followed by all the forces of the east; the other by the strength of the west. Antony's force composed a body of 100,000 foot and 12,000 horse; his fleet amounted to 500 ships of war. The army of Octavianus mustered only 80,000 foot, but equalled his adversary's in number of cavalry: his fleet was but half as numerous as Antony's; however his ships were better built, and manned with better soldiers. The great decisive engagement, which was a naval one, was fought near Actium, a city of Epirus, at the entrance of the gulph of Ambracia. Antony ranged his ships before the mouth of the gulph: and Octavianus drew up his in opposition. The two land armies on opposite sides of the gulph, were drawn up only as spectators. The battle began on both sides with great ardor; nor was there any advantage on either side till of a sudden Cleopatra fled from the engagement attended by sixty sail; what increased the general amazement was to behold Antony himself following soon after. Yet the engagement continued with great obstinacy till 5 P. M., when Antony's forces submitted. The land forces soon after followed the example of the navy; and all yielded without

striving a blow the fourth day after the battle. When Cleopatra met Antony pursued her in a five-oared galley: and coming along side of her ship, entered without seeming or being seen by her. She was in the storm, and he went up the poop, where he remained for some time silent, forming an bond between his hands. In this manner he continued three whole days: during which either through indignation or shame, he neither saw nor spoke to the queen. At last, when they arrived at the promontory of Ventus, Cleopatra's female attendants recomended them, and every thing went on as before. Still, however, he had the consciousness to suppose his army consisted of friends; and accordingly despatched orders to his lieutenant Canidius to conduct it into Asia. When however he arrived in Africa, he was informed of their submission to his rival. This account so transported him with rage that he was hardly prevented from killing himself; at length, at the entreaty of his friends, he returned to Alexandria. Cleopatra, however, seemed to regard that fortunate as her misfortune which had abandoned her admirer. Having amassed considerable riches, by confiscation and other acts of violence, she formed a very singular project, to convey her whole fleet over the isthmus of Suez into the Red Sea, and thus save herself with all her treasures in another region beyond the reach of Rome. Some of her vessels were actually transported further, pursuant to her orders: but the Arabians having burnt them, and Antony dissuading her from the design, she abandoned it for the more improbable scheme of defending Egypt. She made all preparation for war; at least hoping thereby to obtain better terms from Octavianus. In fact, she had always loved Antony's fortunes rather than his person; and if she could have fallen upon any method of saving herself, though even at his expense, she would have embraced it. She even still had some hopes from the power of her charms, though she was almost forty; and was desirous of trying upon Octavianus those arts which had been so successful with the greatest men of Rome. Thus in the three embassies which were sent from Antony to his rival in Asia, the queen had always her secret agents, charged with particular proposals in her name. Antony desired only that his life might be spared, and to pass the rest of his days in obscurity. To these proposals Octavianus made no reply. Cleopatra sent him also public proposals in favor of her children; but at the same time privately resigned him her crown, with all the ensigns of royalty. To the queen's public proposal no answer was given; to her private offer he replied, by giving her assurances of his favor in case she sent away Antony or put him to death. When these negotiations came to the knowledge of Antony, his jealousy and rage were heightened to the utmost. He built a solitary house upon a mole in the sea; where he passed his time, shunning all commerce with mankind, and professing to imitate Timon the man-hater. But his furious jealousy drove him even from this retreat; for hearing that Cleopatra had many secret conferences with one Thyrus, an emissary from Octavianus, he seized upon him, and, having ordered him to be cruelly

scourged, sent him back to his master. Meanwhile, the war was carried vigorously forward, and Egypt was once more the theatre of the contending armies of Rome. Calpas, the lieutenant of Octavianus, took Ptolemais, which opened the whole country to his incursions. Octavianus himself was in the mean time advancing with another army toward Ptolemais, the governor of which gave him possession of the place. Antony, upon his arrival, started out to oppose him, fighting with great desperation, and putting the enemy's cavalry to flight. This slight advantage secured his declining forces, and he reentered Alexandria in triumph. Then, going to the palace, he embraced Cleopatra, and presented her a soldier who had distinguished himself in the late engagement. The queen rewarded him very magnificently: presenting him with a breast-plate and breast-piece of gold. With these, however, the soldier went off the next night to the other army. Antony could not bear this defection: he resolved, therefore, to make a bold extreme effort by sea and land, but previously offered to fight his adversary in single combat. Octavianus coolly replied that Antony had ways enough to die besides single combat. At day-break Antony posted the few troops he had remaining upon a rising ground near the city: whence he sent orders to his galleys to engage the enemy. There he wanted to be a spectator of the combat; and, at first, he saw them advance in good order: but his apprehension was turned into rage, when he saw his ships only saluting those of Octavianus, and both fleets uniting, and falling back into the harbour. At the same time his cavalry deserted him. He tried, however, to lead on his infantry; which were soon vanquished, and himself compelled to return into the town. His anger was now unquenchable: he could not help crying out aloud as he passed that he was betrayed by Cleopatra, and delivered by her to those who, for her sake alone, were his enemies. In these suspicions he was not deceived: for it was by secret orders from the queen that the fleet had passed over to the enemy. Cleopatra had for a long while dreaded the effects of Antony's jealousy; and had some time before prepared a method of obviating any sudden sallies it might produce. Near the temple of Isis she had erected a building, which was secretly designed for a sepulchre. Hence she removed all her treasure and most valuable effects, covering them with torches, faggots, and other combustible matter. This sepulchre she designed to answer a double purpose; as well to screen her from the angry resentments of Antony, as to make Octavianus believe that she would have all her treasures in case he refused her former terms of accommodation. Here, therefore, she retired from Antony, shutting the gates, which were secured with bolts and bars of iron: but in the mean time gave orders to spread a report of her death. This news, which soon reached Antony's ears, all his former rage. He now advanced to battle with the same violence he had used before, before he seemed to desert. He was, however, freed from Antony's rage, and he was freed from all his enemies, and he was



drive him to this last resource. Eros, being commanded to perform this promise, drew the sword, but turning his face plunged it into his own bosom, and died at his master's feet. Antony for a while hung over his faithful servant, and, commending his fidelity, took up the sword, with which stabbing himself in the belly, he fell backward upon a little couch. Before he died he learned that Cleopatra was yet alive, and had himself carried to die in her presence. Octavianus was extremely desirous of getting Cleopatra into his power; having a double motive for his solicitude on this occasion: one to prevent her destroying the treasures she had taken with her into the tomb; the other to preserve her person as an ornament to grace his triumph: and by stratagem at last he obtained his object. In the mean time Octavianus made his entry into Alexandria, and treated the inhabitants with lenity. Two only of particular note were put to death upon this occasion; Antony's eldest son Antyllus, and Cæsario, the son of Julius Cæsar. The rest of Cleopatra's children he treated with great gentleness. When she was recovered from an illness, he came to visit her in person. Cleopatra had been preparing for this interview, and made use of every method she could think of to propitiate the conqueror, and to gain his affection, but in vain. She then ordered an asp to be secretly conveyed to her in a basket of fruit, sent a letter to Octavianus, informing him of her purpose of suicide, and desired to be buried in the same tomb with Antony. She died at the age of thirty-nine, after having reigned twenty-two years. Her death put an end to the monarchy in Egypt.

Having settled the affairs of Egypt, Octavianus left Alexandria in the beginning of September, in the year of Rome 720, with a design to return through Syria, Asia Minor, and Greece, to Italy. On his arrival at Antioch, he found there Tiridates, who had been raised to the throne of Parthia, in opposition to Phrahates, and ambassadors from Phrahates, who were come to solicit the assistance of the Romans against each other. Octavianus gave a friendly answer both to Tiridates and the ambassadors of Phrahates, without intending to help either, but with a design to weaken both. After this, having appointed Messala Corvinus governor of Syria, he marched into Asia, and took up his winter quarters. He spent the winter in settling the several provinces of Asia Minor and the adjacent islands: and early in spring passed into Greece, whence he set out for Rome, which he entered in the month Sextilis, afterwards called August, in three triumphs, which were celebrated for three days together. And now Octavianus was at the height of his wishes, sole master of the whole Roman empire. But, to persuade the people that they still enjoyed their ancient government, he continued the old magistrates, with the same name, pomp, and ornaments: but they were to have no military power; only their old jurisdiction of deciding finally all causes, except such as were capital; and, though some of these last were left to the governor of Rome, yet the chief he referred to himself. He likewise won the hearts of the populace by the cheapness of provisions and plen-

tiful markets, which he encouraged; he frequently entertained them with shows and sports; and by these means kept them in good humor, and made them forget his usurpation and their own slavery. The senate he filled with his own creatures, raising the number of senators to 1000. Several poor senators were supplied with money to discharge the public offices, and he affected a high regard for that body; but divested it of all power. To prevent them from raising new disturbances in the distant provinces, he prohibited any senator to travel out of Italy without leave, except such as had lands in Sicily or Narbonne Gaul. Before he ended his sixth consulship, he took a census of the people, forty-one years after the last; and in this the number of the men fit to bear arms amounted to 463,000, the greatest that had ever been found. He now raised many public buildings, repaired the old ones, and added various stately ornaments to the city, which at this time was, if we may credit ancient writers, about fifty miles in compass, containing nearly 4,000,000 of souls. And now Octavianus, entering upon his seventh consulship with M. Agrippa, and finding all things ripe for his design, went to the senate-house; and there offered to resign his authority, and to put all again into the hands of the people upon the old plan of the republic; but they interrupted him while he was speaking, and after he had done unanimously besought him to take upon himself alone the whole government of the empire. He, with a seeming reluctance, yielded at last to their request, and accepted of the sovereignty for ten years. With this new authority the senate conferred upon him the name of Augustus. Yet, that he might seem to share his power with the senators, he refused to govern all the provinces: assigning to the senate such as were quiet and peaceable. Over the provinces were set such as had been consuls or prætors, with the title of proconsul and prætor.

### PART III.

#### ROME, IMPERIAL.

Thus ended the greatest commonwealth, and began the greatest empire, that had ever been known: an empire which comprehended the greatest, and by far the best part of Europe, Asia, and Africa, being near 4000 miles in length, and about half as much in breadth. As to its annual revenues, they had been reckoned to amount to £40,000,000 of our money. But the Romans now ran headlong into all manner of luxury and effeminacy. The people were become a mere mob. The nobility were indeed more polite than formerly, but idle, venal, vicious, void of patriotism, and solely intent on gaining the favor of the emperor. Augustus, absolute master of the empire, took all methods to ingratiate himself with his soldiers, by whose means he had attained such a height of power. He kept twenty-five legions constantly on foot, amounting to 170,650 men. At sea he had two powerful navies. As to the civil government, he enacted several new laws, and reformed some old ones; and, as he affected to do nothing without the advice of the senate, to the rest of

his titles they added that of father of his country. Augustus next turned his arms against the Spanish nation called Cantabrians and Asturians, who had never been fully subdued. The war terminated, as usual, in favor of the Romans; and these brave nations were forced to receive the yoke, though not without the most violent resistance. By this and his other conquests the name of Augustus became so celebrated that his friendship was courted by the most distant monarchs. Phrahates, king of Parthia, made a treaty with him upon his own terms; gave him four of his own sons, with their wives and children, as hostages, and delivered up the Roman eagles and other ensigns, which had been taken from Crassus at the battle of Carrhæ. He received also an embassy from a king of India, with a letter written in the Greek tongue, in which the Indian monarch informed him that, 'though he reigned over 600 kings, he had so great a value for the friendship of Augustus, that he had sent this embassy on so long a journey on purpose to desire it of him; and that he was ready to meet him at whatsoever place he pleased to appoint; and that upon the first notice he was ready to assist him in whatever was right.' This letter he subscribed by the name of Porus, king of India. Of the ambassadors who set out from India three only reached Augustus, who was then in the island of Samos, the others dying by the way. One of the number was named Zarmar, a gymnosophist, who followed the emperor to Athens, and there burnt himself in his presence; it being customary for the gymnosophists to put an end to their lives in this manner, when they thought they had lived long enough. Soon after this the Roman dominions were extended southward over the Garamantes, a people whose country reached as far as the Niger. All this time the emperor continued to make new regulations for the good of the state; and among other things caused the Sibylline oracles to be reviewed. Many of them he rejected; but such as were reckoned authentic he caused to be copied by the pontifices, and lodged them in golden cabinets, which he placed in the temple of Apollo.

The Roman empire had now extended itself so far that it seemed to have arrived at the limits prescribed to it by nature; and it soon after began to be attacked by those nations which in process of time were to overthrow it. The Germans, in which name the Romans included a great number of nations dwelling in the northern parts of Europe, began to make incursions into Gaul. Their first attempt happened in the year 17 B. C., when they at first gained an inconsiderable advantage, but were soon driven back with great loss. Soon after this, the Rhæti, who inhabited the country bordering on the lake of Constance, invaded Italy where they committed dreadful devastations, putting all the males to the sword without distinction of rank or age. Against these barbarians Augustus sent Drusus, the second son of the empress Livia; who, though very young, gained a complete victory with very little loss. Those who escaped took the road to Gaul, being joined by the Vindelici, another nation in the neighbourhood; but Tiberius, the

elder brother of Drusus, marched against them and overthrew them so completely, that the Rhæti, Vindelici, and Norici, three of the most barbarous nations in those parts, were obliged to submit. To keep their country in awe, Tiberius planted two colonies in Vindelicia, opening a road thence into Noricum and Rhætia. One of the cities which he built for the defence of his colonies was called Drysomagus; the other Augusta Vindelicorum; now called Memmingen and Augsburg. Augustus, who had long since obtained all the temporal honors which could well be conferred upon him, now began to assume those of the spiritual kind also; being in the year 13 B. C. created pontifex maximus: an office which he continued to hold till his death; as did also his successors in the time of Theodosius. By virtue of his office, he corrected a very gross mistake in the Roman calendar; for the pontifices having, for the space of thirty-six years, that is, ever since the reformation by Julius Cæsar, made every third year a leap year, instead of every fourth, twelve days had been inserted instead of nine, so that the Roman year consisted of three days more than it ought to have done. These three days having been thrown out, the form of the year has ever since been regularly observed, till the Gregorian or New Style came to be adopted throughout Europe, and is still known by the name of the Old Style among us. On this occasion he gave his own name to the month of August, as Julius Cæsar had formerly done to July. In the year 11 B. C. Agrippa died, and was succeeded in his employment of governor of Rome by Tiberius; but, before investing him with this ample power, the emperor caused him to divorce his wife Agrippina (who had already brought him a son, and was then big with child), to marry Julia, the widow of Agrippa, and daughter of the emperor. Julia was a princess of an infamous character, as was known to every body, excepting Augustus himself; however, Tiberius made no hesitation. The emperor now sent his two step-sons, Tiberius and Drusus, against the northern nations. Tiberius reduced the Pannonians, who had attempted to shake off the yoke after the death of Agrippa. Drusus performed great exploits in Germany; but, while he was considering whether he should penetrate further into these northern countries, he was seized with a violent fever, which carried him off in a few days. He was succeeded in the command by Tiberius, who is reported to have done great things, but certainly made no permanent conquests in Germany. However, he was honored with a triumph, and had the tribunitial power for five years conferred upon him; which was no sooner done than, to the great surprise of Augustus and the whole city, he desired leave to quit Rome, and retire to Rhodes. A profound peace now reigned throughout the whole empire; and in consequence of this the temple of Janus was shut, which had never before happened since the reign of Numa Pompilius. During this pacific interval, the Saviour of mankind was born in Judæa, 748 years after the building of Rome. Three years after Tiberius returned to the city, by permission of Augustus, but in a short time his grandsons

Lucius Cæsar and Caius Cæsar died, not without suspicion of being poisoned by Livia. Augustus was exceedingly concerned at their death, and immediately adopted Tiberius as his son; he adopted also Agrippa Posthumus, the third son of the famous Agrippa; and obliged Tiberius to adopt Germanicus, the son of his brother Drusus, though he had a son of his own named Drusus. As to Agrippa, who might have been an occasion of jealousy, Tiberius was soon freed from him by his disgrace and banishment, which soon took place, but on what account is not known. The northern nations now began to be formidable: and, though it is pretended that Tiberius was always successful against them, yet about this time they gave the Roman legions a most terrible overthrow: three legions and six cohorts, under Quintilius Varus, being almost entirely cut in pieces. Augustus set no bounds to his grief on this occasion. Tiberius, however, was soon after sent into Germany; and for his exploits there was honored with a triumph. Augustus now took him for his colleague in the sovereignty; after which he sent Germanicus against the northern barbarians, and Tiberius into Illyricum. This was the last of his public acts; for, having accompanied Tiberius part of his journey, he died at Nola in Campania, in the seventy-sixth year of his age, and fifty-sixth of his reign. Livia was suspected of having hastened his death by poisoned figs.

**TIBERIUS.**—Tiberius, who succeeded to the empire, resolved to secure himself on the throne by the murder of Agrippa, whom accordingly he caused to be put to death by a military tribune. Though this might have been a sufficient evidence of what the Romans had to expect, the death of Augustus was no sooner known than the two consuls first took an oath of fidelity to the emperor, and then administered it to the senate, the people, and the soldiery. Tiberius behaved in a dark mysterious manner, ruling with absolute sway, but seeming to hesitate whether he should accept the sovereign power or not. He had scarcely taken possession of the throne, when news was brought him that the armies in Pannonia and Germany had mutinied. In Pannonia they were terrified into submission by an eclipse of the moon; but the revolt of the German legions threatened more danger. After Germanicus had granted all their demands, and quieted them, as he supposed, fresh disturbances broke out. He then thought it necessary to provide for the safety of his family, by sending his lady Agrippina from the camp with many of the wives of other officers. This made such a deep impression on the mutineers that they intreated Germanicus to recal his wife; and the soldiers of their own accord seized and massacred the ringleaders of the revolt. Still, however, two of the legions continued disobedient; but, on hearing of the return of their companions to their duty, those who had remained true rose and massacred the whole of the revolters. The sedition being thus quelled, Germanicus led his army into Germany, where he performed various exploits; but was still far from freeing the empire from its dangerous and troublesome enemy. A. D. 19 he died, of poison

as was supposed, given by Piso, his partner in the government of Syria, to which Germanicus had been promoted after his return from the north. In the mean time Tiberius, though he affected to court the favor of the people by various methods, yet showed himself in general such a cruel and blood-thirsty tyrant that he became the object of universal abhorrence. Though he had hated Germanicus, he punished Piso with death; and about a year after, having no object of jealousy to keep him in awe, he began daily to diminish the authority of the senate: this was much facilitated by their own adulation; so that, while he despised their meanness, he enjoyed its effects. A law subsisted which made it treason to form any injurious attempt against the majesty of the people. Tiberius assumed to himself the interpretation and enforcement of this law. All freedom was now therefore banished from convivial meetings, and suspicion reigned amongst the dearest relations. The law of offended majesty being revived, many persons of distinction fell a sacrifice to it. In the beginning of these cruelties, Tiberius took into his confidence Sejanus, a Roman knight, by birth a Volscian, who gained his confidence by the most refined dissimulation, being an over-match for his master in his own arts. He was made by the emperor captain of the prætorian guards, one of the most confidential trusts in the state. The servile senators, with ready adulation, set up the statues of the favorite beside those of Tiberius, and seemed eager to pay him similar honors. It was from such humble beginnings that this minister even ventured to aspire at the throne, and was resolved to make the emperor's foolish confidence one of the first steps to his ruin. However, he considered that cutting off Tiberius alone would rather retard than promote his designs, while his son Drusus and the children of Germanicus were yet remaining. He therefore began by seducing Livia, the wife of Drusus, whom he prevailed upon to poison her husband. Tiberius, in the mean time, not much regarding his son, bore his death with great tranquillity. Sejanus resolved to make his next attempt on the children of Germanicus, who were undoubted heirs to the empire. However, he was frustrated, both by the fidelity of their governors, and the chastity of Agrippina their mother. On this he resolved upon removing Tiberius out of the city. He began to insinuate to him the numerous inconveniences of the city, the fatigues of attending the senate, and the seditious temper of the citizens. Tiberius, either prevailed upon by his persuasions, or pursuing the natural turn of his temper, which led to indolence and debauchery, quitted Rome, therefore, in the twelfth year of his reign, and went into Campania, under pretence of dedicating temples to Jupiter and Augustus. After this he never returned to the capitol; but spent the greatest part of his time in the island of Caprea, a place rendered infamous by his pleasures. He spent whole nights at the table; and his luxuries of other kinds were still more detestable. From the time of his retreat, he also became more cruel, and Sejanus endeavoured to increase his distrusts. Every day he found his aim succeeding; the

wretched emperor's terrors were an instrument by which he levelled every obstacle. He so contrived to widen the breach between the emperor and the sons of Germanicus, that at length Nero and Drusus were declared enemies of the state, and starved to death in prison; while Agrippina their mother was sent into banishment. In this manner Sejanus proceeded, removing all who stood between him and the empire: the number of his statues exceeded even those of the emperor; and he was more dreaded than even the tyrant who enjoyed the throne. But the rapidity of his rise was only preparatory to the greatness of his downfall. All we know of his first disgrace with the emperor is that Satrius Secundus was the man who had the boldness to accuse him: Antonia, the mother of Germanicus, seconded the accusation: but he was very near despatching Tiberius, when his practices were discovered. The emperor ordered the senate to put him in prison; but they went beyond their orders, and directed his execution. His body was ignominiously dragged about the streets, and his whole family executed with him.

Sejanus's death seemed only to kindle the emperor's rage for further executions. The prisons were crowded with pretended accomplices in the conspiracy of Sejanus: but Tiberius began to grow weary of particular executions; he therefore gave orders that all the accused should be put to death without examination, and often feasted his eyes with the tortures of the wretches put to death before him. In the mean time the frontier provinces were invaded with impunity by the barbarians. *Mæsia* was seized on by the *Dacians* and *Sarmatians*; *Gaul* by the *Germans*, and *Armenia* by the king of *Parthia*. Tiberius, however, was so much a slave to his appetites, that he left the provinces entirely to the care of his lieutenants, and they were intent rather on the accumulation of private fortunes than the safety of the state. At length, in the twenty-second year of his reign, he began to feel the approaches of dissolution, and nominated Caligula for his successor: soon after he fell into such faintings, as all believed were fatal. It was in this situation that, by Macro's advice, Caligula prepared to secure the succession. He received the congratulations of the court, caused himself to be acknowledged by the prætorian soldiers, and went forth from the emperor's apartment amidst the applauses of the multitude; when on a sudden he was informed that the emperor was recovered, had begun to speak, and desired to eat. Macro, however, who was hardened in crimes, ordered that the dying emperor should be despatched, by smothering him with pillows; or, as other historians state, by poison. Thus died Tiberius, in the seventy-eighth year of his age, after reigning twenty-two. The Romans were, at this time, arrived at the highest pitch of effeminacy and vice: the wealth of almost every nation of the empire, having, for some time, circulated through the city, brought with it the luxuries peculiar to each; so that Rome presented a detestable picture of pollution. In the eighteenth year of this monarch's reign, Christ was crucified.

CALIGULA.—No monarch ever came to the  
VOL. XVIII.

throne with more advantages than Caligula. He received the congratulations of the people on every side, all equally pleased with being free from the cruelties of Tiberius, and in hoping new advantages from the virtues of his successor. Caligula at first certainly took every method to impress them with the expectation of a happy change. Amidst the rejoicings of the multitude, he advanced mourning, with the dead body of Tiberius, which the soldiers brought to be burnt at Rome. Upon his entrance into the city, he was received with new titles of honor by the senate; for though left co-heir with Gemellus, grandson to Tiberius, they set aside Gemellus, and declared Caligula sole successor to the empire. Having performed the funeral solemnities of Tiberius, he hastened to the islands of *Pandataria* and *Pontia*, to remove the ashes of his mother and brothers, exposing himself to tempestuous weather to give a lustre to his piety. Having brought them to Rome, he instituted annual solemnities in their honor, and ordered September to be called *Germanicus*, in memory of his father. He conferred the same honors upon his grandmother Antonia which had been given to Livia; and ordered all informations to be burnt that any way exposed the enemies of his family. He even refused a paper that was offered him, tending to the discovery of a conspiracy against him; alleging that he was conscious of nothing to deserve any man's hatred, and therefore had no fears. He caused the institutions of Augustus, which had been disused in the reign of Tiberius, to be revived; undertook to reform many abuses in the state, and severely punished corrupt governors. He banished the spintrix or inventors of abominable recreations from Rome; attempted to restore the ancient manner of electing magistrates by the suffrages of the people; and gave them a free jurisdiction, without any appeal to himself. Although the will of Tiberius was annulled by the senate, and that of Livia suppressed by Tiberius, yet he caused all their legacies to be punctually paid; and, to make Gemellus amends for missing the crown, he caused him to be elected princeps juvenutis, or principal of the youth. He restored some kings to their dominions who had been unjustly dispossessed by Tiberius, and gave them the arrears of their revenues. And, that he might appear an encourager of every virtue, he ordered a female slave a large sum of money, for enduring the most exquisite torments without discovering the secrets of her master. So many concessions, and such apparent virtue, could not fail of receiving just applause. A shield of gold, bearing his image, was decreed to be carried annually to the capitol, attended by the senate and the sons of the nobility singing in praise of the emperor's virtues. It was likewise ordained that the day on which he was appointed to the empire should be called *Pubitia*; implying that, when he came to govern, the city received a new foundation. But in less than eight months all this show of virtue and clemency vanished; while furious passions, unexemplated avarice, and capricious cruelty, began to rule his mind. As most of the cruelties of Tiberius arose from suspicion, so most of those committed by Caligula took their rise from prodigality. Some assert

that a disorder, which happened soon after his accession to the empire, deranged his understanding. Indeed madness itself could scarcely dictate cruelties more extravagant, or inconsistencies more ridiculous, than are imputed to him. Gemellus he obliged to kill himself. Silenus, the emperor's father-in-law, was the next that was put to death upon slight suspicion; and Gerincus, a senator of noted integrity, refusing to witness falsely against him, shared his fate. After these followed a crowd of victims to the emperor's avarice or caprice. Among the number of those who were thus sacrificed was Macro, the late favorite of Tiberius, and the person to whom Caligula owed the empire. Not long after, he assumed divine honors, and gave himself the names of such divinities as he thought most agreeable to his nature. For this purpose he caused the heads of the statues of Jupiter and some other gods to be struck off, and his own to be put in their places. He frequently seated himself between Castor and Pollux, and ordered that all who came to their temple to worship should pay their adorations only to him; nay, at last, he altered their temple to the form of a portico, which he joined to his palace, that the very gods, as he said, might serve him in the quality of porters. He was not less notorious for the depravation of his appetites than for his ridiculous presumption. Neither person, place, nor sex, were obstacles to the indulgence of his lusts. There was scarcely a lady of any quality in Rome that escaped him; and, indeed, such was the degeneracy of the times, that there were very few who did not think this disgrace an honor. He is said to have committed incest with his three sisters, and at public feasts they lay with their heads upon his bosom. Of these he prostituted Livia and Agrippina to his vile companions, and then banished them as adulteresses and conspirators. As for Drusilla, he took her from her husband Longius, and kept her as his wife. Her he loved so affectionately, that, being sick, he appointed her heiress of his empire and fortune; and when she happened to die before him made her a goddess. Yet to mourn for her death was a crime, as she was become a goddess; while to rejoice for her divinity was capital, because she was dead. Nay, even silence itself was an unpardonable insensibility, either of the emperor's loss, or his sister's advancement. But of all his vices, his prodigality was perhaps the most remarkable. The most notorious instance of this fruitless profusion was the vast bridge at Puteoli, which he undertook in the third year of his reign. He caused a great number of ships to be fastened to each other, so as to make a floating bridge from Baiæ to that place, across an arm of the sea three miles and a half broad. The ships being placed in two rows, in form of a crescent, were secured to each other with anchors, chains, and cables. Over these were laid vast quantities of timber, and upon that earth, so as to make the whole resemble one of the streets of Rome. He next caused several houses to be built upon his new bridge, for the reception of himself and his attendants, into which fresh water was conveyed by pipes from land. At night, the number of

torches and other illuminations with which this expensive structure was adorned, cast such a gleam as illuminated the whole bay, and all the neighbouring mountains. Expenses like these would have exhausted the most unbounded wealth: in fact, after reigning about a year, Caligula found his revenues exhausted; and a treasure of about £18,000,000 of our money, which Tiberius had amassed, entirely spent in extravagance and folly. Now, therefore, his prodigality put him upon new methods of supplying the exchequer; and, as before his profusion, so now his rapacity became boundless. He put in practice all kinds of rapine and extortion. Every thing was taxed, to the very wages of the meanest tradesmen. He had poisoned many who had named him for their heir, to have the immediate possession of their fortunes, and set up a brothel in his own palace, from which he gained considerable sums by prostitution. He also kept a public gaming-house. On one occasion, having had a series of ill luck, he saw two rich knights passing through the court; on which he rose, and, causing both to be apprehended, confiscated their estates: then, rejoining his companions, he boasted that he had never had a better throw in his life. Another time, wanting money for a stake, he went down and caused several noblemen to be put to death; and then, returning, told the company that they sat playing for trifles while he had won 60,000 sesterces at a cast. Such insupportable and capricious cruelties produced many conspiracies against him; the issue of which was only deferred by his intended expedition in the third year of his reign against the Germans and Britons. His mighty preparations, however, ended in nothing. Instead of conquering Britain and Germany, he only gave refuge to a banished prince; and led his army to the sea-shore in Batavia. At last a plan for taking him off was concerted under the influence of Cassius Cherea, tribune of the prætorian bands, joined by Valerius Asiaticus, whose wife the emperor had debauched, Annius Vincianus, Clemens the præfect, and Calistus, whose riches made him obnoxious to the tyrant. While these were deliberating upon the most certain method of destroying him, an unexpected incident gave new strength to the conspiracy. Pomedius, a senator of distinction, having been accused before the emperor, of having spoken of him with disrespect, one Quintilia, an actress, was cited to confirm the accusation. Quintilia, however, was possessed of an uncommon degree of fortitude. She denied the fact, and, being put to the torture at the informer's request, bore the severest torments with unshaken constancy. After several deliberations, it was at last resolved to attack him during the continuance of the Palatine games: he was accordingly slain in a little vaulted gallery that led to the bath, in the twenty-ninth year of his age, after a reign of three years, ten months, and eight days. With him his wife and infant daughter also perished; one being stabbed by a centurion, the other having its brains dashed out again: the wall. His coin was also melted down by a decree of the senate; and such precautions were taken.

that all seemed willing that neither his features nor his fame might be transmitted to posterity.

CLAUDIUS.—As soon as the death of Caligula was made public, it produced the greatest confusion in Rome. The conspirators, who only aimed at destroying a tyrant, all retired without naming a successor, to private places. Some thought the report of the emperor's death was an artifice of his own, to see how his enemies would behave: and in this interval of suspense, the German guards pillaged the city under pretence of revenging the emperor's death. All the conspirators and senators that fell in their way received no mercy. However, they grew calm by degrees, and the senate was permitted to assemble, to deliberate upon what was necessary to be done. In this deliberation, Saturninus, who was then consul, insisted much upon the benefits of liberty; and his language was highly pleasing to the senate; but the populace and the army opposed them. The former remembered the donations and public spectacles of the emperors. The latter were sensible they could have no power but in a monarchy. In this opposition of interests and opinions, chance at last decided the fate of the empire. Some soldiers, running about the palace, discovered Claudius, Caligula's uncle, concealed in a secret place. Of this personage, hitherto despised for his imbecility, they resolved to make an emperor; and accordingly carried him upon their shoulders to the camp, where they proclaimed him at a time when he expected death. The senate went soon after in a body, to render him homage: when the first who fell a sacrifice to the jealousy of this new monarch was Cherea. He met death with all the fortitude of an ancient Roman. Lupus, his friend, suffered with him; and Sabinus, one of the conspirators, laid violent hands on himself. Claudius was fifty years old when he began to reign: and the complicated diseases of his infancy had affected all the faculties of his body and mind. Yet the commencement of his reign gave the most promising hopes. He began by passing an act of oblivion for all former words and actions, and disannulled the cruel edicts of Caligula. He forbade all persons, under severe penalties, to sacrifice to him as they had done to the late emperor; was assiduous in hearing and examining complaints; and frequently administered justice in person; tempering by his mildness the severity of the law. He took a more than ordinary care that Rome should be continually supplied with corn and provisions, securing the merchants against pirates. He was not less assiduous in his buildings, in which he excelled almost all that went before him, and constructed an aqueduct, called after his own name, much surpassing any other in Rome both for workmanship and its plentiful supply of water, which it brought from forty miles distance, furnishing the highest parts of the city. He made also a haven at Ostia, of such immense expense that his successors were unable to maintain it. But his greatest work of all was the draining of the lake Fucinus, the largest in Italy, and bringing its water into the Tiber, to strengthen the current of that river. For effecting this, among other difficulties, he mined

through a mountain of stone three miles broad, and kept here 30,000 men employed for eleven years. To this solicitude for the internal advantages of the state, he added that of a watchful guardianship over the provinces. He even undertook to gratify the people by foreign conquest. The Britons, who had, for nearly 100 years, been left in sole possession of their own island, began to seek the mediation of Rome, to quell their intestine commotions. The principal man who desired to subject his native country to the Roman dominion was one Bericus, who persuaded the emperor to make a descent upon the island, magnifying the advantages that would attend the conquest of it. Plautius the prætor was accordingly ordered to pass over into Gaul, and made preparations for this expedition; and the Britons, under their king Cynobelinus, were several times overthrown. These successes soon after induced Claudius to go into Britain in person, upon pretence that the natives were still seditious, and had not delivered up some Roman fugitives who had taken shelter among them; but, for an account of the exploits of the Romans in this island, see ENGLAND. But Claudius soon began to lessen his care for the public, and to commit to his favorites all the concerns of the empire. The chief of his directors was his wife Messalina; whose name has hence become a common appellation for women of abandoned character. However, she was not less remarkable for her cruelties than her licentiousness; and destroyed many of the most illustrious families of Rome. Subordinate to her were the emperors' freedmen; Pallas, the treasurer; Narcissus, the secretary of state; and Callistus, the master of the requests. These entirely governed Claudius; so that he was only left the fatigues of ceremony, while they possessed all the power of the state. It would be tedious to enumerate the various cruelties which these insidious advisers obliged the feeble emperor to commit: those against his own family will suffice. Appius Silanus, a person of great merit, who had been married to the emperor's mother-in-law, was put to death upon the suggestions of Messalina. After him he slew both his sons-in-law, Silanus and Pompey, and his two nieces the Livia, one the daughter of Drusus the other of Germanicus; without permitting them to plead in their defence, or even without assigning any cause. Great numbers of others fell sacrifices to the jealousy of Messalina and her minions. Every thing was put to sale: they took money for pardons and penalties; and accumulated by these means enormous sums. These disorders in the ministers produced conspiracies against the emperor. Statius Corvinus and Gallus Assinius formed one conspiracy: two knights privately combined to assassinate him; but the revolt which gave him the greatest uneasiness, and which was punished with the most unrelenting severity, was that of Camillus, his lieutenant-general in Dalmatia. This general, incited by many of the principal men in Rome, openly rebelled, and assumed the title of emperor. Nothing could exceed the terrors of Claudius, upon being informed of this revolt; so that, when Camillus commanded him by letters to

relinquish the empire, he seemed inclined to give obedience. However, his fears were soon removed; for the legions which had declared for Camillus, being terrified by some prodigies, soon after killed him. The cruelty of Messalina and her minions upon this occasion seemed to have no bounds. They so wrought upon the emperor's fears and suspicions that numbers were executed without trial or proof; and scarcely any who were but suspected escaped. By such cruelties as these his favorites endeavoured to establish his and their own authority. He now became a prey to jealousy and disquietude, and his only relief seemed to be in inflicting tortures. Suetonius says that there were no fewer than thirty-five senators, and above 300 knights, executed in this reign. In this manner was Claudius urged on by Messalina to commit every kind of enormity. After appearing for some years insatiable in her desires, she at length fixed her own affections upon Caius Silius, the most beautiful youth in Rome. Her love for this young Roman seemed to amount to madness. She obliged him to divorce his wife Junia Syllana; she gave him immense treasures and valuable presents; the very imperial ornaments were transferred to his house; and the emperor's slaves and attendants had orders to wait upon the adulterer. Nothing was wanting to complete their insolence but their being married; and this was also effected. They relied upon the emperor's imbecility for their security, and only waited till he retired to Ostia to put their project in execution. Some time before there had been a quarrel between Messalina and Narcissus, the emperor's first freed-man, who watched for an opportunity of ruining the empress. He communicated to Claudius what had happened, and urged him to revenge without delay. Nothing could exceed the consternation of Messalina and her companions upon being told that the emperor was coming. Every one retired in the utmost confusion. Silius was taken. Messalina took shelter in some gardens which she had seized upon, having expelled Asiaticus the owner and put him to death. Thence she sent Britannicus, her only son by the emperor, with Octavia her daughter, to intercede for her. She soon after followed him; but Narcissus had fortified the emperor against her arts, and she was obliged to return in despair. Silius was instantly put to death in the emperor's presence; and Narcissus, without authority, ordered that Messalina should share the same fate. Claudius was informed of her death in the midst of his banquet without the least appearance of emotion. The emperor, being now a widower, declared publicly that he would remain single for the future, and would forfeit his life if he broke his resolution. But his resolution was but of short continuance. His freed-men, after some deliberation, fixed upon Agrippina, the daughter of his brother Germanicus, for his wife. This woman was more practised in vice than even the former empress. As the late declaration of Claudius seemed to be an obstacle to his marrying, persons were suborned to move in the senate that he should be compelled to take a wife, as a matter of great importance to the commonwealth. When this decree passed, Claudius had scarcely

patience to wait a day before the celebration for his nuptials. Having now received a new director, he submitted with more implicit obedience than in any former part of his reign. Agrippina's chief aims were to secure the succession in favor of her young son Nero, and to set aside the claims of Britannicus. For this purpose she married Nero to the emperor's daughter Octavia, a few days after her own marriage. Not long after this she urged the emperor to strengthen the succession, in imitation of his predecessors, by making a new adoption; and caused him to take in her son Nero to divide the fatigues of government. Her next care was to increase her son's popularity by giving him Seneca for a tutor. This subtle woman pretended the utmost affection for Britannicus, whom, however, she resolved to destroy; and, shortly after her accession, she procured the death of several ladies who had been her rivals. She displaced the captain of the guard; and appointed Burrhus to that command; a person of great military knowledge and strongly attached to her interests. From that time she took less pains to disguise her power. In the twelfth year of Claudius she persuaded him to restore liberty to the Rhodians, of which he had deprived them some years before; and to remit the taxes of the city Ilium, as having been the progenitors of Rome. Her design in this was to increase the popularity of Nero, who pleaded the cause of both cities with great approbation. Such an immoderate use of her power at last awakened the emperor's suspicions. Agrippina's imperious temper began to grow insupportable to him; and he declared, when heated with wine, that it was his fate to suffer the disorders of his wives and to be their executioner. This expression engaged all her faculties to prevent the blow. Her first care was to remove Narcissus, whom she hated upon many accounts. This minister at length thought fit to retire, by a voluntary exile, into Campania. The unhappy emperor seemed regardless of the dangers that threatened his destruction. His affection for Britannicus every day increased, which served also to increase the vigilance and jealousy of Agrippina. She now, therefore, resolved to poison her husband, and determined upon a poison to destroy his intellects, and yet not suddenly to terminate his life. This not having the desired effect, however, she directed a wretched physician to thrust a poisoned feather down his throat, under pretence of making him vomit, and thus despatched him.

NERO.—Claudius being destroyed, Agrippina took every precaution to conceal his death from the public until she had settled her measures for securing the succession. A strong guard was placed at all the avenues of the palace, while she amused the people with various reports; at one time giving out that he was still alive, at another that he was recovering. In the meanwhile, she made sure of the person of young Britannicus, under a pretence of affection for him. At last, when all things were adjusted, the palace gates were thrown open, and Nero, accompanied by Burrhus, prefect of the prætorian guards, issued to receive the congratulations of the people and the army. The cohorts, then attending,

proclaimed him with the loudest acclamations, though not without making some enquiries after Britannicus. He was carried in a chariot to the rest of the army; wherein, having made a speech suited to the occasion, and promising them a donation, he was declared emperor by the army, the senate, and the people. Nero's first care was to show all possible respect to the deceased emperor, to cover the guilt of his death. His obsequies were performed with a pomp equal to that of Augustus; the young emperor pronounced his funeral oration, and he was canonised among the gods. The funeral oration, though spoken by Nero, was drawn up by Seneca; and this was the first time a Roman emperor needed the aid of another's eloquence. Nero, though but seventeen years of age, began his reign with general approbation. As he owed the empire to Agrippina he submitted to her directions with the most implicit obedience. On her part she seemed resolved on governing with her natural ferocity, and considered her private animosities as the only rule to guide her in public justice. Immediately after the death of Claudius she caused Silanus, the pro-consul of Asia, to be assassinated. The next object of her resentment was Narcissus, Claudius's favorite; a man notorious for the greatness of his wealth and the number of his crimes. He was obliged to put an end to his life by Agrippina's order. This bloody outset would have been followed by many more severities had not Seneca and Burrhus opposed them. These worthy men, although they owed their rise to the empress, were above being the instruments of her cruelty. They therefore combined together, and, gaining the young emperor on their side, formed a plan of power both merciful and wise. The beginning of Nero's reign, while he acted by their counsels, has always been considered as a model for princes. In fact, the young monarch knew so well how to conceal his innate depravity that his nearest friends could scarcely perceive his virtues to be assumed. He appeared just, liberal, and humane. His condescension and affability were not less than his other virtues; so that the Romans began to think that his clemency would compensate for the tyranny of his predecessors. In the mean time Agrippina, who was excluded from any share in government, attempted to recover her power. Perceiving that her son had fallen in love with a freed-woman named Acte, and dreading the influence of a concubine, she tried every art to prevent his growing passion. The gratification of his passion, therefore, in this instance, only served to increase his hatred for the empress. Nor was it long before he gave evident marks of his disobedience by displacing Pallas her chief favorite. Upon this occasion she first perceived the total declension of her authority; which threw her into the most ungovernable fury. She said that Britannicus, the real heir to the throne, was still living, and in a condition to receive his father's empire which was now possessed by an usurper. She threatened to go to the camp, and there expose his baseness and her own, invoking all the furies to her assistance. These menaces alarmed the suspicions of Nero; who had begun to give way to his natural de-

pravity. He, therefore, determined upon the death of Britannicus, and contrived to have him poisoned at a public banquet. Agrippina, however, took every opportunity of obliging and flattering the tribunes and centurions; she heaped up treasures with a rapacity beyond her natural avarice; all her actions seemed calculated to raise a faction, and make herself formidable to the emperor. Whereupon Nero commanded her German guard to be taken from her, and obliged her to lodge out of the palace. He also forbid particular persons to visit her, and went himself but rarely and ceremoniously to pay her his respects. She now therefore began to find that, with the emperor's favor, she had lost the assiduity of her friends. As Nero increased in years, his crimes increased. He took pleasure in running about the city by night, disguised like a slave. In this habit he entered taverns and brothels, attended by the lewd ministers of his pleasures, attempting the lives of such as opposed him, and frequently endangering his own. After his example numbers of profligate young men infested the streets likewise; so that every night the city was filled with tumult and disorder. However the people bore all these levities with patience, having occasion every day to experience his liberality, and having also been gratified by the abolition of many of their taxes. The provinces were no way affected by these riots; for except disturbances on the side of the Parthians, which were soon suppressed, they enjoyed the most perfect tranquillity. But those sensualities, which, for the first four years of his reign, produced but few disorders, in the fifth became alarming. He first began to transgress the bounds of decency, by publicly abandoning Octavia his wife, and taking Poppæa, the wife of his favorite Otho. This was another grating circumstance to Agrippina, who vainly used all her interest to disgrace Poppæa, and reinstate herself in her son's lost favor. This last began her arts by urging him to divorce his wife and marry herself. She insinuated the dangerous designs of Agrippina; and by degrees accustomed his mind to reflect on parricide without horror. His cruelties against his mother began rather by various circumstances of petty malice than by any downright injury; but at last, finding these ineffectual to break her spirit, he resolved on putting her to death. After attempting poison and other modes ineffectually, he sent a body of soldiers to her house, who killed her with several wounds. He vindicated his conduct next day to the senate; who not only excused but applauded his impiety. Nero now gave a loose to his appetite, that were not only sordid but inhuman. There seemed an odd contrast in his disposition; for, while he practised cruelties sufficient to make the mind shudder with horror, he was fond of those amusing arts that soften and refine the heart. He was particularly addicted, even from childhood, to music, and not totally ignorant of poetry. But chariot-driving was his favorite pursuit. He enclosed a space in the valley of the Vatican, and exhibited his dexterity to the whole of his subjects. Their praises stimulated him still more to these pursuits; so that he now



resolved to appear as a singer upon the stage. His first public appearance was at games of his own institution, called juveniles; where he advanced upon the stage, tuning his instrument to his voice. A group of tribunes and centurions attended behind him; when his old governor Burrhus stood by his hopeful pupil, with indignation in his countenance, and praises on his lips. He was desirous also of becoming a poet; but he was unwilling to undergo the pain of study. Nor was he without his philosophers also; he took a pleasure in hearing their debates after supper. Furnished with such talents as these, he was resolved to make the tour of his empire, and give the most public display of his abilities. The place of his first exhibition, upon leaving Rome was Naples. The crowds there were so great, and the curiosity of the people so earnest in hearing him, that they did not perceive an earthquake that happened while he was singing. His desire of gaining the superiority over the other actors was truly ridiculous. While he continued to perform, no man was permitted to depart from the theatre upon any pretence whatsoever. Some were so fatigued with hearing him that they leaped privately from the walls, or pretended to fall into fainting fits, in order to be carried out. Vespasian, afterwards emperor, happening to fall asleep on one of these occasions, very narrowly escaped with his life. After being fatigued with the praises of his countrymen, Nero resolved upon going over into Greece, to receive new theatrical honors. There he exhibited in all the games, and obtained from the meanness of the Greeks 1800 crowns. His entry into Rome on his return was attended with more splendor than a triumph. So many honors only inflamed his desires of acquiring new; he at last began to take lessons in wrestling; willing to imitate Hercules in strength, as he had rivalled Apollo in activity. He also caused a lion of pasteboard to be made with great art, against which he undauntedly appeared in the theatre, and struck it down with a blow of his club. But his cruelties outdid all his other extravagancies, a complete list of which would exceed our limits. He often said that he had rather be hated than loved. When one said in his presence, that the world might be burned when he was dead; 'Nay,' replied Nero, 'let it be burnt while I am alive.' In fact, a great part of the city of Rome was burnt soon after. This remarkable conflagration took place in the eleventh year of Nero's reign. Nero, who was then at Antium, did not return to the city till he heard that the flames were advancing to his palace, which, after his arrival, was burnt down to the ground, with all the houses adjoining to it. However Nero, affecting compassion for the multitude bereft of their dwellings, laid open the field of Mars, and all the great edifices erected there by Agrippa, and even his own gardens; he likewise caused tabernacles to be reared in haste for the reception of the forlorn populace. From Ostia too, and the neighbouring cities, were brought by his orders all sorts of furniture and necessaries; and the price of corn was considerably lessened. But these bounties, however generous and popu-

lar, were bestowed in vain, because a report was spread abroad that, during the time of this general conflagration, he mounted his domestic stage, and sung the destruction of Troy, comparing the desolation of Rome to that of Troy. At length, on the sixth day, the fury of the flames was stopped at the foot of mount Esquiline, by levelling with the ground a vast number of buildings. But scarcely had the alarm ceased, when the fire broke out anew with fresh rage, but in places more wide and spacious; whence fewer persons were destroyed, but more temples and public porticoes were overthrown. As this second conflagration broke out in certain buildings belonging to Tigellinus, they were both ascribed to Nero; and it was supposed that, by destroying the old city, he aimed at the glory of building a new one, and calling it by his name. Of the fourteen quarters into which Rome was divided, four remained entire, three were laid in ashes, and, in the seven other, remained here and there a few houses, miserably shattered and half consumed. Among the many ancient and stately edifices, which the rage of the flames utterly consumed, Tacitus reckons the temple dedicated by Servius Tullius to the moon; the temple and great altar consecrated by Evander to Hercules; the chapel by Romulus to Jupiter Stator; the court of Numa, with the temple of Vesta, and in it the tutelary gods peculiar to the Romans. In the same fate were involved the inestimable treasures acquired by so many victories, the wonderful works of the best painters and sculptors of Greece, and, what is still more to be lamented, the ancient writings of celebrated authors, till then preserved entire. The fire began the same day on which the Gauls formerly burnt it to the ground. Upon the ruins of the demolished city Nero founded a palace, which he called his golden house; though it was not so much admired on account of an immense profusion of gold, precious stones, and other inestimable ornaments, as for its vast extent, containing spacious fields, large wildernesses, artificial lakes, thick woods, orchards, vineyards, hills, groves, &c. The ground that was not taken up by the foundation of Nero's own palace, he assigned for houses, which were not placed at random, and without order, but the streets were laid out regularly, spacious, and straight; the edifices restrained to a certain height, of about seventy feet; the courts were widened; and to all the great houses, which stood by themselves, and were called isles, large porticoes were added, which Nero engaged to raise at his own expense, and to deliver to each proprietor the squares about them clear from all rubbish. Thus the city in a short time rose out of its ashes with new lustre, and more beautiful than ever. The emperor used every art to throw the odium of this conflagration upon the Christians, who were at that time gaining ground in Rome. Nothing could be more dreadful than the persecution raised against them upon this false accusation, of which an account is given under the article HISTORY. Hitherto, however, the citizens of Rome seemed comparatively exempted from his cruelties, which chiefly fell upon strangers and his nearest connexions; but a conspiracy

formed against him by Piso, a man of great power and integrity, which was prematurely discovered, opened a new train of suspicions that destroyed many of the principal families in Rome. Piso, Lateranus, Fennius Rufus, Subrius Flavius, Sulpicius Asper, Vestinus the consul, and numberless others, were all executed. But the two most remarkable personages who fell on this occasion were Seneca the philosopher, and Lucan the poet, his nephew. It is not known whether Seneca was really concerned or not. He was ordered to put himself to death, which he did, by opening his veins in a warm bath. Thus was the whole city filled with slaughter and frightful instances of treachery. No master was secure from the vengeance of his slaves, nor even parents from the baser attempts of their children. Not only throughout Rome, but the whole country round, bodies of soldiers were seen in pursuit of the suspected and the guilty. Whole crowds of wretches loaded with chains were led every day to the gates of the palace, to wait their sentence from the tyrant. He always presided at the torture in person, attended by Tigellinus, captain of the guard, who, being the most abandoned man in Rome, was become his principal minister and favorite. Nor were the Roman provinces in a better situation than the capital. The example of the tyrant influenced his governors, who gave instances of their rapacity and cruelty in every part of the empire. In the seventh year of his reign the Britons revolted, under the conduct of their queen Boadicea (see ENGLAND); but were at last so completely defeated that ever after, during the continuance of the Romans among them, they lost not only all hopes, but even all desire of freedom. A war also was carried on against the Parthians for the greatest part of this reign, conducted by Corbulo; who, after many successes, had dispossessed Tiridates, and settled Tigranes in Armenia in his room. Tiridates, however, was soon after restored by an invasion of the Parthians into that country; but, being once more opposed by Corbulo, the Romans and Parthians came to an agreement that Tiridates should continue to govern Armenia, upon condition that he should lay down his crown at the foot of the emperor's statue, and receive it as coming from him; all which he performed. This ceremony Nero desired to have repeated to his person; wherefore he invited Tiridates to Rome, granting him the most magnificent supplies for his journey. Nero attended his arrival with very sumptuous preparations. He received him seated on a throne, accompanied by the senate standing round him, and the whole army drawn out with all imaginable splendor.—Tiridates ascended the throne with great reverence; and approaching the emperor, fell down at his feet, and in the most abject terms acknowledged himself his slave. Nero raised him up, telling him with equal arrogance, that he did well, and that by his submission he had gained a kingdom which his ancestors could never acquire by their arms. He then placed the crown on his head, and, after the most costly ceremonies and entertainments, he was sent back to Armenia, with incredible sums of money to defray the expenses of his return. In the twelfth year of Nero's reign

the Jews revolted, having been severely oppressed by the Roman governor. Florus was arrived at that degree of tyranny that by public proclamation he gave permission to plunder the country, provided he received half the spoil. These oppressions drew such a train of calamities after them, that the sufferings of all other nations were slight in comparison to what this devoted people afterwards endured, as is related under the article JEWS. In the mean time Nero proceeded in his cruelties at Rome with unabated severity. The valiant Corbulo, who had gained so many victories over the Parthians, could not escape his fury. Nor did the empress Poppæa herself escape; whom, in a fit of anger, he kicked when she was pregnant, by which she miscarried and died. At last the Romans began to grow weary of such a monster, and there appeared a general revolution in all the provinces. The first appeared in Gaul, under Julius Vindex, who commanded the legions there, and publicly protested against the tyrannical government of Nero. He appeared to have no other motive for this revolt than that of freeing the world from an oppressor; for when it was told him that Nero had set a reward upon his head of 10,000,000 of sesterces, he made this gallant answer, 'Whoever brings me Nero's head, shall, if he pleases, have mine.' But, to show that he was not actuated by motives of private ambition, he proclaimed Sergius Galba emperor, and invited him to join in the revolt. Galba, who was then governor of Spain, was equally remarkable for his wisdom in peace, and his courage in war. But, as all talents under corrupt princes are dangerous, he for some years lived in obscurity, avoiding all opportunities of signalling his valor. He now, therefore, either through the caution attending old age, or from a total want of ambition, appeared little inclined to join with Vindex. In the mean time Nero, who had been apprised of the proceedings against him in Gaul, appeared totally regardless of the danger, flattering himself that the suppression of this revolt would give him an opportunity of fresh confiscations. But the revolt of Galba, the news of which arrived soon after, affected him in a very different manner. The reputation of that general was such that, from the moment he declared against him, Nero considered himself as undone. He resolved to massacre all the governors of provinces, to destroy all exiles, and to murder all the Gauls in Rome, as a punishment for the treachery of their countrymen. In short, in the wildness of his rage, he thought of poisoning the whole senate, of burning the city, and turning the lions kept for the purposes of the theatre out upon the people. These designs being impracticable, he resolved at last to face the danger in person. But his very preparations served to mark the infatuation of his mind. His principal care was to provide waggons for the convenient carriage of his musical instruments; and to dress out his concubines like Amazons, with whom he intended to face the enemy. While Nero was thus frivolously employed, the revolt became general. Not only the armies in Spain and Gaul, but also the legions in Germany, Africa, and Lusitania, declared against him. Virginius Rufus alone, who commanded

an army on the Upper Rhine, for a while continued in suspense; during which his forces, without his permission, falling upon the Gauls, routed them with great slaughter, and Vindex slew himself. But this ill success no way advanced the interests of Nero; he was so detested by the whole empire that he could find none of the armies faithful to him. He therefore called for Locusta to furnish him with poison; and, thus prepared for the worst, he retired to the Servilian gardens, with a resolution of flying into Egypt. He accordingly despatched the freedmen in whom he had the most confidence, to prepare a fleet at Ostia; and in the mean while sounded, in person, the tribunes and centurions of the guard, to know if they were willing to share his fortunes. But they all excused themselves under divers pretences. Thus destitute of every resource, all the expedients that cowardice, revenge or terror could produce, took place in his mind by turns. He at one time resolved to take refuge among the Parthians; at another, to deliver himself up to the mercy of the insurgents; one while he determined to mount the rostrum, to ask pardon for what was past, and to conclude with promises of amendment for the future. With these gloomy deliberations he went to bed; but waking about midnight, he was surprised to find his guards had left him. The prætorian soldiers, in fact, having been corrupted by their commander, had retired to their camp, and proclaimed Galba emperor. Nero immediately sent for his friends to deliberate upon his present exigence; but his friends also forsook him. He went from house to house, but all the doors were shut against him, and none were found to answer his enquiries; his very domestics followed the general defection; and, having plundered his apartment, escaped different ways. Being now reduced to desperation, he desired that one of his favorite gladiators might come and despatch him; but even in this request there was none found to obey. 'Alas!' cried he, 'have I neither friend nor enemy?' And then, running desperately forth, he seemed resolved to plunge headlong into the Tiber. But just then, his courage failing him, he made a sudden stop, as if willing to recollect his reason; and asked for some secret place, where he might reassume his courage, and meet death with becoming fortitude. In this distress, Phaon, one of his freedmen, offered him his country house, about four miles distant, where he might for some time remain concealed. Nero accepted his offer; and arrived with difficulty in safety. During this interval the senate, finding the prætorian guards had taken part with Galba, declared him emperor, and condemned Nero to die *more majorum*; that is, to be stripped naked, his head fixed in a pillory, and in that posture to be scourged to death. Nero was so terrified on hearing this, that he set a dagger to his throat, with which, by the assistance of Epaphroditus, his freed man and secretary, he gave himself a mortal wound. He expired in the thirty-second year of his age and the fourteenth of his reign. See NERO.

**GALBA.**—Galba was seventy-two years old when he was declared emperor, and was then in Spain with his legions. However, he soon found

that his being raised to the throne was but an inlet to new disquietudes. His first embarrassment arose from a disorder in his own army; for, upon his approaching the camp, one of the wings of horse repenting of their choice, prepared to revolt, and he found it no easy matter to reconcile them to their duty. He also narrowly escaped assassination from some slaves, who were presented to him by one of Nero's freedmen with that intent. The death of Vindex also served to add to his disquietudes. But hearing from Rome that Nero was dead, and the empire transferred to him, he immediately assumed the title and ensigns of command. In his journey towards Rome, he was met by Virginius Rufus, who, finding the senate had decreed him the government, came to yield him obedience. This general had more than once refused the empire himself, which was offered him by his soldiers; alleging that the senate alone had the disposal of it, and from them only he would accept the honor. Galba, having been brought to the empire by his army, was at the same time desirous to suppress their power to commit any future disturbance. His first approach to Rome was attended with one of those rigorous strokes of justice which ought rather to be denominated cruelty than any thing else. A body of mariners, whom Nero had taken from the oar and enlisted among the legions, went to meet Galba three miles from the city, and with loud importunities demanded a confirmation of what his predecessor had done in their favor. Galba, who was rigidly attached to the ancient discipline, deferred their request to another time. But they, considering this delay as equivalent to an absolute denial, insisted in a very disrespectful manner; and some of them even had recourse to arms, whereupon Galba ordered a body of horse attending him to ride in among them, and thus killed 7000 of them; and afterwards ordered them to be decimated. His next step to curb the insolence of the soldiers was his discharging the German cohort, which had been established by the former emperors as a guard to their persons. These he sent home to their own country unrewarded, pretending they were disaffected to his person. He seemed to have two other objects also in view; namely, to punish those vices which had come to an enormous height in the last reign with the strictest severity; and to replenish the exchequer, which had been quite drained by the prodigality of his predecessors. But these attempts only brought on him the imputation of severity and avarice; for the state was too much corrupted to admit of such an immediate transition from vice to virtue. The people had long been maintained in sloth and luxury by the prodigality of the former emperors, and could not think of being obliged to seek for new means of subsistence, and to retrench their superfluities. They began, therefore, to satirise the old man, and turn the simplicity of his manners into ridicule. By ill-judged frugalities, at such a time, Galba began to lose his popularity; and he, who before his accession was esteemed by all, when become emperor, was considered with contempt. Shortly after his coming to Rome, the people were presented with a most grateful spectacle, which was that of Lo-

custa, Ælius, Policletus, Petronius, and Petinus, all bloody ministers of Nero's cruelty, drawn in fetters through the city, and publicly executed. But Tigellinus, who had been more active than all the rest, was not there. The crafty villain had taken care for his own safety, by the largeness of his bribes; and, though the people cried out for vengeance against him at the theatre and at the circus, yet the emperor granted him his life and pardon. Helotus, the eunuch, also, who had been the instrument of poisoning Claudius, escaped, and owed his safety to the proper application of his wealth. Thus, by the inequality of his conduct, he became despicable. At one time showing himself severe and frugal, at another remiss and prodigal; condemning some illustrious persons without any hearing, and pardoning others though guilty: in short, nothing was done but by the mediation of his favorites; all offices were venal, and all punishments redeemable by money. While affairs were in this unsettled posture at Rome, the provinces were yet in a worse condition. The success of the armies in Spain in choosing an emperor induced the legions in the other parts to wish for a similar opportunity. Many seditions were kindled and factions promoted in different parts of the empire, particularly in Germany. There were then in that province two Roman armies; the one had lately attempted to make Virginius Rufus emperor, and was commanded by his lieutenant; the other was commanded by Vitellius, who long had an ambition to obtain the empire for himself. The former of these armies, despising their present general, and considering themselves as suspected by the emperor for having been the last to acknowledge his title, resolved now to be foremost in denying it. Accordingly, when they were summoned to take the oaths of homage and fidelity, they refused to acknowledge any other commands but those of the senate. This refusal they backed by a message of the prætorian bands, importing that they were resolved not to acquiesce in the election of an emperor created in Spain, and desiring that the senate should proceed to a new choice. Galba, being informed of this commotion, was sensible, that, besides his age, he was less respected for want of an heir. He resolved, therefore, to put what he had formerly designed in execution, and to adopt some person whose virtues might deserve such advancement, and protect his declining age from danger. His favorites, understanding his determination, instantly resolved to give him an heir of their own choosing; so that there arose a great contention among them upon this occasion. Otho made warm application for himself; alleging the great services he had done the emperor, as being the first man of note who came to his assistance when he had declared against Nero. However, Galba, being fully resolved to consult the public good alone, rejected his suit; and, on a day appointed, ordered Piso Lucilianus to attend him. The character given by historians of Piso, is, that he was every way worthy of the honor designed him. He was no way related to Galba; and had no other interest but merit to recommend him to his favor. Taking this youth, therefore, by the hand, in the

presence of his friends, he adopted him to succeed in the empire, giving him the most wholesome lessons for guiding his future conduct. Piso's conduct showed that he was highly deserving this distinction; and in all his deportment there appeared such modesty, firmness, and equality of mind, as bespoke him rather capable of discharging than ambitious of obtaining the imperial dignity. But the army and the senate did not seem equally disinterested upon this occasion; they had been so long used to bribery and corruption that they could now bear no emperor who was not in a capacity of satisfying their avarice. The adoption therefore of Piso was but coldly received; for his virtues were no recommendation in a nation of universal depravity. Otho now finding his hopes of adoption wholly frustrated, and still further stimulated by the immense load of debt which he had contracted by his riotous way of living, resolved upon obtaining the empire by force, since he could not by peaceable succession. In fact his circumstances were so very desperate that he was heard to say, that it was equal to him whether he fell by his enemies in the field, or by his creditors in the city. He therefore raised a moderate sum of money, by selling his interest to a person who wanted a place; and with this bribed two subaltern officers in the prætorian bands, supplying the deficiency of largesses by promises and plausible pretences. Having thus, in less than eight days, corrupted the fidelity of the soldiers, he stole secretly from the emperor while he was sacrificing; and, assembling the soldiers, in a short speech urged the cruelties and avarice of Galba. Finding these his invectives received with universal shouts by the whole army, he threw off the mask, and avowed his intentions of dethroning him. The soldiers, ripe for sedition, immediately seconded his views: taking Otho upon their shoulders, they instantly proclaimed him emperor; and, to strike the citizens with terror, carried him with their swords drawn into the camp. Galba, in the mean time, being informed of the revolt of the army, seemed utterly confounded, and in want of resolution to face an event which he should have long foreseen. In this manner the poor old man continued wavering and doubtful; till at last, being deluded by a false report of Otho's being slain, he rode into the forum in complete armour, attended by many of his followers. Just at the same instant a body of horse sent from the camp to destroy him entered on the opposite side, and each party prepared for the encounter. For some time hostilities were suspended on each side; Galba confused and irresolute, and his antagonists struck with horror at the baseness of their enterprise. At length, finding the emperor in some measure deserted by his adherents, they rushed in upon him, trampling under foot the crowds of people that then filled the forum. Galba, seeing them approach, seemed to recollect all his former fortune; and, bending his head forward, bid the assassins strike it off if it were for the good of the people. This was quickly performed; and his head, being set upon the point of a lance, was presented to Otho, who ordered it to be contemptuously carried round

the camp; his body remaining exposed in the streets till it was buried by one of his slaves. He died in the seventy-third year of his age, after a short reign of seven months.

**OTHO.**—No sooner was Galba thus murdered than the senate and people ran in crowds to the camp, contending who should be foremost in extolling the virtues of the new emperor, and depressing the character of him they had so unjustly destroyed. Each labored to excel the rest in his instances of homage; and the less his affections were for him, the more did he indulge all the vehemence of exaggerated praise. Otho, finding himself surrounded by congratulating multitudes, immediately repaired to the senate, where he received the titles usually given to the emperors; and thence returned to the palace, seemingly resolved to reform his life, and assume manners becoming the greatness of his station. He began his reign by a signal instance of clemency, in pardoning Marius Celsus, who had been highly favored by Galba; and, not contented with barely forgiving, he advanced him to the highest honors; asserting that 'fidelity deserved every reward.' This act of clemency was followed by another of justice, equally agreeable to the people. Tigellinus, Nero's favorite, he who had been the promoter of all his cruelties, was now put to death; and all such as had been unjustly banished, or stripped, at his instigation, during Nero's reign, were restored to their country and fortunes. In the mean time the legions in Lower Germany, having been purchased by the large gifts and specious promises of Vitellius their general, were at length induced to proclaim him emperor; and, regardless of the senate, declared that they had an equal right to appoint to that high station with the cohorts at Rome. The news of this conduct in the army soon spread conternation throughout Rome; but Otho was particularly struck with the account, as being apprehensive that nothing but the blood of his countrymen could decide a contest of which his own ambition only was the cause. He now therefore sought to come to an agreement with Vitellius; but, this not succeeding, both sides began their preparations for war. News being received that Vitellius was upon his march to Italy, Otho departed from Rome with a vast army to oppose him. But, though he was very powerful with regard to numbers, his men, being little used to war, could not be relied on. He seemed by his behaviour sensible of the disproportion of his forces; and he is said to have been tortured with frightful dreams, and the most uneasy apprehensions. It is also reported that one night, fetching many profound sighs in his sleep, his servants ran hastily to his bed side, and found him stretched on the ground. He alleged he had seen the ghost of Galba, which had, in a threatening manner, beat and pushed him from his bed; and he afterwards used many expiations to appease it. However this be, he proceeded with a great show of courage till he arrived at the city of Brixellum, on the Po, where he remained, sending his forces before him under his generals Suetonius and Celsus, who made what haste they could to give the enemy battle. The army of Vitellius, which consisted of 70,000 men,

was commanded by his generals Valens and Cecina, he himself remaining in Gaul in order to bring up the rest of his forces. Thus both sides hastened to meet each other with so much animosity and precipitation that three considerable battles were fought in three days: one near Placentia, another near Cremona, and a third at a place called Castor; in all which Otho had the advantage. But these successes were but short lived; for Valens and Cecina, who had hitherto acted separately, joining their forces, and reinforcing their armies with fresh supplies, resolved to come to a general engagement. Otho, who by this time had joined his army at a little village called Bedriacum, finding the enemy, notwithstanding their late losses, inclined to come to a battle, resolved to call a council of war to determine upon the proper measures to be taken. His generals were of opinion to protract the war; but others, whose inexperience had given them confidence, declared that nothing but a battle could relieve the miseries of the state; protesting, that fortune and all the gods with the divinity of the emperor himself, favored the design, and would undoubtedly prosper the enterprise. In this advice Otho acquiesced; he had been for some time so uneasy under the war that he seemed willing to exchange suspense for danger. However, he was so surrounded with flatterers that he was prohibited from being personally present in the engagement, but prevailed upon to reserve himself for the fortune of the empire, and wait the event at Brixellum. The affairs of both armies being thus adjusted, they came to an engagement at Bedriacum; where, in the beginning, those on the side of Otho seemed to have the advantage. At length the superior discipline of the legions of Vitellius turned the scale of victory. Otho's army fled in great confusion towards Bedriacum, being pursued with a miserable slaughter all the way. In the mean time Otho waited for the news of the battle with great impatience, and seemed to tax his messengers with delay. The first account of his defeat was brought him by a soldier, who had escaped from the field of battle. However Otho, who was still surrounded by flatterers, was desired to give no credit to a base fugitive, who was guilty of falsehood only to cover his own cowardice. The soldier, however, still persisted in the veracity of his report; and, finding none inclined to believe him, immediately fell upon his sword, and expired at the emperor's feet. Otho was so much struck with the death of this man, that he cried out, that he would cause the ruin of no more such valiant and worthy soldiers, but would end the contest the shortest way; and therefore, having exhorted his followers to submit to Vitellius, he put an end to his own life.

**VITELLIUS.**—It was no sooner known that Otho had killed himself than all the soldiers repaired to Virginius, the commander of the German legions, earnestly entreating him to take upon him the reins of government; or at least intreating his mediation with the generals of Vitellius in their favor. Upon his declining their request, Rubrius Gallus, a person of considerable note, undertook their embassy to the gene-

erals of the conquering army ; and soon after obtained a pardon for all the adherents of Otho. Vitellius was immediately after declared emperor by the senate ; and received the marks of distinction which now followed the strongest side. At the same time Italy was severely distressed by the soldiers, who committed such outrages as exceeded all the oppressions of the most calamitous war. Vitellius, who was yet in Gaul, resolved, before he set out for Rome, to punish the prætorian cohorts, who had been the instruments of all the late disturbances in the state. He therefore caused them to be disarmed, and deprived of the name and honor of soldiers. He also ordered 150 of those who were most guilty to be put to death. As he approached towards Rome, he passed through the towns with all imaginable splendor ; his passage by water was in painted galleys, adorned with garlands of flowers, and profusely furnished with the greatest delicacies. In his journey there was neither order nor discipline among his soldiers ; they plundered wherever they came with impunity ; and he seemed no way displeased with their licentiousness. Upon his arrival at Rome he entered the city, not as a place he came to govern with justice, but as a town that became his own by the laws of conquest. He marched through the streets mounted on horseback, all in armor ; the senate and people going before him, as if captives of his late victory. He the next day made the senate a speech, in which he magnified his own actions, and promised them extraordinary advantages from his administration. He then harangued the people, who, being now long accustomed to flatter all in authority, highly applauded their new emperor. In the mean time his soldiers, being permitted to satiate themselves in the debaucheries of the city, grew totally unfit for war. The principal affairs of the state were managed by the lowest wretches. Vitellius, more abandoned than they, gave himself up to all kinds of luxury and profuseness : but gluttony was his favorite vice, so that he brought himself to a habit of vomiting, in order to renew his meals at pleasure. His entertainments, though seldom at his own cost, were prodigiously expensive ; he frequently invited himself to the tables of his subjects, breakfasting with one, dining with another, and supping with a third, all in the same day. In this manner did Vitellius proceed ; so that, Josephus tells us, if he had reigned long, the whole empire would not have been sufficient to have maintained his gluttony. Those who had formerly been his associates were now destroyed without mercy. Going to visit one of them in a violent fever, he mingled poison with his water, and delivered it to him with his own hands. He never pardoned those money-lenders who came to demand payment of his former debts. One of the number coming to salute him, he immediately ordered him to be carried off to execution ; but shortly after, commanding him to be brought back, when all his attendants thought it was to pardon the unhappy creditor, Vitellius gave them soon to understand that it was merely to have the pleasure of feeding his eyes with his torments. Having condemned another to

death, he executed his two sons with him, only for their presuming to intercede for their father. A Roman knight being dragged away to execution and crying out that he had made the emperor his heir, Vitellius desired to see the will, where finding himself joint heir with another, he ordered both to be executed, that he might enjoy the legacy without a partner. By continuing such vices and cruelties as these he became odious, and the astrologers prognosticated his ruin. A writing was set up in the forum, in the name of the ancient Chaldeans, giving Vitellius warning to depart this life by the kalends of October. Vitellius received this information with terror, and ordered all the astrologers to be banished from Rome. A woman having foretold that, if he survived his mother, he should reign many years in happiness, he put her to death, by refusing her sustenance, under the pretence of its being prejudicial to her health. But he soon saw the futility of such prognostics ; for his soldiers, by their cruelty and rapine, having become insupportable to the inhabitants of Rome, the legions of the east began to revolt, and soon after resolved to make Vespasian emperor. Vespasian, who was commander against the Jews, had reduced most of their country, except Jerusalem, to subjection ; but the death of Nero, and the succession of Galba, gave a temporary check to his conquests as he was obliged to send his son Titus to Rome. Titus, however, being detained by contrary winds, received news of Galba's death before he sailed. He then resolved to continue neuter during the civil war between Otho and Vitellius ; and when the latter prevailed he gave him his homage with reluctance. But, being desirous of acquiring reputation, he determined to lay siege to Jerusalem. The murmurings against Vitellius increased every day, while Vespasian endeavoured to advance the discontents of the army, who began at length to fix upon him as the person most capable of terminating the miseries of his country. Not only his own legions, but those in Mœsia and Pannonia, declared themselves for Vespasian. He was also proclaimed emperor at Alexandria, the army there confirming it with extraordinary applause. Still, however, Vespasian declined the honor ; till at length his soldiers compelled him, with threats of immediate death. He now called a council of war : where it was resolved that his son Titus should carry on the war against the Jews ; and that Mutianus, one of his generals, should, with great part of his legions, enter Italy ; while Vespasian should levy forces in all parts of the east, to reinforce them in case of necessity. Mean time Vitellius resolved to make an effort to defend the empire ; and his chief commanders, Valens and Cecina, were ordered to make all preparations to resist the invaders. The first army that entered Italy was under Antonius Primus, who was met by Cecina near Cremona, whom he prevailed upon to change sides, and declare for Vespasian. His army, however, quickly repented of what they had done ; and imprisoning their general, though without a leader, attacked Antonius. The engagement continued the whole night : in the morning, after a short repast, both armies en-

gaged a second time; when the soldiers of Antonius saluting the rising sun, according to custom, the Vitellians supposing that they had received new reinforcements, betook themselves to flight, with the loss of 30,000 men. Soon after, freeing Cecina from prison, they prevailed upon him to intercede with the conquerors for pardon; which they obtained, though not without the most horrid barbarities committed in Cremona. When Vitellius was informed of the defeat of his army, his insolence was converted into extreme timidity. At length he commanded Julius Priscus and Alphenus Varus, with some forces that were in readiness, to guard the passes of the Apennines, to prevent the enemy's march on Rome. But, being persuaded to repair to his army in person, his presence only increased the contempt of his soldiers. After a short continuance in the camp, and hearing the revolt of his fleet, he returned to Rome. Every day rendering his affairs more desperate, he made offers to Vespasian of resigning the empire. One Sabinus, who had advised him to resign, perceiving his desperate situation, resolved, by a bold step, to oblige Vespasian, and seized upon the capitol. But he was premature in his attempt; for the soldiers of Vitellius attacked him with great fury, and, prevailing by their numbers, soon laid that building in ashes. During this conflagration, Vitellius was feasting in the palace of Tiberius, and beholding with satisfaction the horrors of the assault. Sabinus was taken prisoner, and shortly after executed. Domitian, Vespasian's son, afterwards emperor, escaped by flight, in the habit of a priest; and all the rest, who survived the fire, were put to the sword. But this success served little to improve the affairs of Vitellius. He vainly sent messenger after messenger to bring Vespasian's general, Antonius, to a compromise. This commander gave no answer to his requests, but continued his march towards Rome. Being arrived before the walls of the city, the forces of Vitellius were resolved upon defending it to the utmost extremity. Attacked on three sides with the greatest fury; the army within, sallying upon the besiegers, defended it with equal obstinacy. The battle lasted a whole day, till at last the besieged were driven into the city, and a dreadful slaughter made of them in the streets. In the meantime, the citizens stood by apparently unconcerned, as if they had been in a theatre, and clapped their hands, first at one party's success, and then at the other's. As either turned their backs, the citizens would fall upon and plunder them. But, what was still more remarkable, during these dreadful slaughters both within and without the city, the people celebrated one of their riotous feasts, called the Saturnalia; so that in various parts might be seen the strange mixture of mirth and misery, profligacy and slaughter; in a word, all the horrors of civil war, and all the licentiousness of the most abandoned security! During this complicated scene, Vitellius retired to his wife's house, upon mount Aventine, designing to fly to the army commanded by his brother at Tarracina. But he changed his mind, and returned to his palace. There, after wandering disconsolate, he hid himself in an

obscure corner, whence he was soon taken by a party of soldiers. Still, willing to add a few hours to his miserable life, he begged to be kept in prison till the arrival of Vespasian at Rome, pretending that he had secrets of importance to discover. But his intreaties were vain; the soldiers binding his hands behind him, and throwing a halter round his neck, led him along, half naked, into the public forum, upbraiding him as they proceeded with all the bitter reproaches that malice could suggest, or his own cruelties deserve. They also tied his hair backwards, as was usual with the most infamous malefactors, and held the point of a sword under his chin, to prevent his hiding his face from the public. Personal indignations were heaped upon him. Some cast dirt and filth upon him as he passed, others struck him with their hands, or ridiculed the defects of his person. At length, being despatched, they dragged his dead body through the streets with a hook, and threw it, with all possible ignominy, into the Tiber. Such was the miserable end of this emperor, in the fifty-seventh year of his age, after a short reign of eight months and five days.

VEASPASIAN.—The conquering army of Vespasian now pursued their enemies throughout the city, where neither houses nor temples afforded them refuge. Not only the enemy suffered thus, but many of the citizens, who were obnoxious to the soldiers, were dragged from their houses, and killed. They next began to seek for plunder; the rabble joining in these outrages: some slaves discovered the riches of their masters; some were detected by their nearest friends; and the whole city was filled with outcry and lamentation. At length, however, upon the arrival of Mutianus, these slaughters ceased, and the state began to wear the appearance of former tranquillity. Vespasian was declared emperor by the unanimous consent both of the senate and the army, and messengers were despatched to him into Egypt, desiring his return. But the winter being dangerous for sailing he deferred his voyage. The dissensions in other parts of the empire also retarded his return; for Claudius Civilis, in Lower Germany, excited his countrymen to revolt, and destroyed the Roman garrisons. To give his rebellion, however, an air of justice, he caused his army to swear allegiance to Vespasian, though he soon disclaimed all submission to his government; and having overcome one or two of the lieutenants, and being joined by such Romans as refused obedience to the new emperor, he boldly advanced to give Cerealis, Vespasian's general, battle. After some temporary reverses Cerealis not only routed the enemy but took and destroyed their camp. The engagement, however, was not decisive; several others ensued, and an accommodation at length took place, when Civilis obtained peace for his countrymen and pardon for himself. During these commotions in Germany the Sarmatians, a barbarous nation in the north-east of the empire, suddenly passed the Iser, and marched into the Roman dominions with such celerity as to destroy several garrisons, and an army under Fonteius Agrippa. However, they were driven back by Rubrius Gallus into their native forests; while several attempts were

made to confine them by garrisons and forts. But these hardy nations, having once found the way into the empire, never after desisted from invading it. Before Vespasian set out for Rome, he gave his son Titus the command of the army that was to besiege Jerusalem; he then went forward, and was met many miles from Rome by all the senate and nearly half the inhabitants. Nor did he in the least disappoint their expectations; being equally prompt to reward merit and pardon his adversaries; in reforming the manners of the citizens and setting them the best example in his own. In the mean time Titus carried on the war against the Jews with that vigor which ended in the total destruction of the city. See JEWS. After this his soldiers would have crowned him as conqueror; but he refused the honor, alleging that he was only an instrument in the hand of heaven, that manifestly declared its wrath against the Jews. At Rome, however, all mouths were filled with his praises. His return, therefore, in triumph, with his father, was celebrated with all possible magnificence and joy. Among the rich spoils were vast quantities of gold taken out of the temple, with the book of the Jewish law. A triumphal arch was erected on this occasion, which remains almost entire to this day, and on which were inscribed all the victories of Titus over the Jews. Vespasian likewise built a temple to Peace, wherein were deposited most of the spoils; and, having now calmed all the commotions in the empire, he shut the temple of Janus, which had been open about five or six years. Vespasian, having thus given security and peace to the empire, resolved to correct numberless abuses which had grown up under his predecessors. To effect this with greater ease, he joined Titus with him in the consulship and tribunitian power, and in some measure admitted him a partner in all the highest offices of the state. He began with restraining the licentiousness of the army, and forcing them back to their pristine discipline. He abridged the processes that had been carried to an unreasonable length in the courts of justice. He rebuilt such parts of the city as had suffered in the late commotions; particularly the capitol, which he restored to more than its former magnificence. He likewise built an amphitheatre, the ruins of which are still an evidence of its ancient grandeur. The other ruinous cities of the empire also shared his paternal care; he improved such as were declining, adorned others, and built many anew. In such acts as these he passed a long reign of clemency and moderation; so that it is said no man suffered by an unjust or a severe decree during his administration. Julius Sabinus seems to have been the only person who was treated with greater rigor than usual by this emperor. Sabinus was commander of a small army in Gaul, and had declared himself emperor upon the death of Vitellius. His army, however, was soon after overcome by Vespasian's general, and he himself compelled to fly. For some time he wandered through the provinces, but, finding the pursuit every day become closer, he was obliged to hide himself in a cave: in which he remained concealed for no less than nine years, attended all the time by his faithful wife, who

purchased provisions for him by day, and repaired to him in the night. She was at last discovered in the performance of this pious office, and Sabinus was carried to Rome. Great intercession was made to the emperor on his behalf; Empona herself appearing with her two children, imploring her husband's pardon. But Sabinus had been too dangerous a rival, and he was executed. This seems to be the only instance in which Vespasian resented past offences. He caused the daughter of Vitellius, his avowed enemy, to be married into a noble family, and he himself provided her a suitable fortune. One of Nero's servants coming to beg pardon for having once rudely thrust him out of the palace, and insulted him when in office, Vespasian took his revenge by serving him just in the same manner. When any conspiracies were formed against him, he disdained to punish the guilty, saying, that they deserved rather his contempt for their ignorance than his resentment; as they seemed to envy him a dignity of which he daily experienced the uneasiness. His liberality towards the encouragement of arts and learning, was not less than his clemency. He settled a constant salary of 100,000 sesterces upon the teachers of rhetoric. He was particularly favorable to Josephus, the Jewish historian. Quintilian the orator, and Pliny the naturalist, flourished in his reign, and were highly esteemed by him. He was no less an encourager of all other excellencies in art; and invited the greatest masters and artificers from all parts of the world, making them considerable presents. Yet all his numerous acts of generosity and magnificence could not preserve his character from the imputation of rapacity and avarice. He revived many obsolete methods of taxation: and even bought and sold commodities himself, to increase his fortune. He is charged with advancing the most avaricious governors to the provinces, to share their plunder on their return to Rome. He descended to some very dishonorable imposts, even to the laying a tax upon urine. When his son Titus remonstrated against the meanness of such a tax, Vespasian, taking a piece of money, demanded if the smell offended him; and then added that this very money was produced by urine. But, in excuse for this, the exchequer, when Vespasian came to the throne, was so much exhausted that he informed the senate that it would require a supply of £300,000,000 (of our money) to re-establish the commonwealth. But, while the provinces were thus obliged to contribute to the support of the power, he took every precaution to provide for their safety; so that we find but two insurrections in this reign. In the fourth year of his reign Antiochus, king of Comagena, holding a private correspondence with the Parthians, the declared enemies of Rome, was taken prisoner in Cilicia, by Pyrrhus the governor, and sent bound to Rome. But Vespasian generously gave him residence at Lacedæmon, and allowed him a revenue suitable to his dignity. About the same time the Alani, a barbarous people inhabiting along the river Tanais, abandoned their barren wilds, and invaded the kingdom of Media. Thence passing into Armenia, after great ravages, they overthrew king



Tiridates with prodigious slaughter. Titus was set to chastise their insolence; but the barbarians retired at the approach of a Roman army, loaded with plunder. These incursions, however, were but a transient storm, the effect of which were soon repaired by the emperor's moderation and assiduity. He now formed and established a thousand nations, which had scarcely before amounted to 200. He had during his whole reign a particular regard to Britain; his generals, Petilius Cerealis, and Julius Frontinus, brought the greatest part of the island into subjection; and Agricola, who succeeded soon after, completed what they had begun. See ENGLAND. In this manner, having reigned ten years, loved by his subjects, and deserving their affection, he was surprised by an indisposition at Campania, which he at once declared would be fatal, crying out in the spirit of Paganism, 'methinks I am going to be a god.' Removing thence to the city, and afterwards to a country seat near Reate, he was there taken with a flux, which brought him to the last extremity. However, perceiving his end approach, and just going to expire, he cried out that an emperor ought to die standing; wherefore, raising himself upon his feet, he expired in the hands of those that sustained him.

**TITUS VESPASIAN.**—Titus, being joyfully received as emperor, began his reign with every virtue that became an emperor and a man. During the life of his father there had been many imputations against him; but, upon his exaltation to the throne, he seemed entirely to take leave of his former vices, and became an example of the greatest moderation and humanity. He had long loved Berenice, sister to Agrippa king of Judea, a woman of the greatest beauty and allurements. But, knowing that the connexion with her was disagreeable to the people of Rome, he sent her away, notwithstanding their mutual passion and the many arts she used to induce him to change his resolution. He next discarded all those who had been the former ministers of his pleasures, and forbore to countenance the companions of his looser recreations, though he had formerly taken great pains in their selection. This moderation, added to his justice and generosity, procured him the love of all good men, and the appellation of the delight of mankind, which all his actions seemed calculated to ensure. As he came to the throne with all the advantages of his father's popularity, he was resolved to use every method to increase it. He therefore took particular care to punish all informers, false witnesses, and promoters of dissension, condemning them to be scourged in public, dragged through the theatre, and banished to the uninhabited parts of the empire, and sold as slaves. His courtesy and readiness to do good have been celebrated even by Christian writers; his principal rule being never to send any petitioner away dissatisfied. One night, recollecting that he had done nothing beneficial to mankind the day preceding, he said, 'My friends, to day I have lost a day.' In this reign, an eruption of mount Vesuvius did considerable damage, overwhelming many towns, and sending its ashes into countries more than 100 miles distant. Upon this memorable occasion,

Pliny the naturalist lost his life; for, being impelled by too eager a curiosity to observe the eruption, he was suffocated in the flames. There happened also about this time a fire at Rome, which continued three days and nights successively, which was followed by a plague, in which 10,000 men were buried in a day. The emperor, however, did all that lay in his power to repair the damage sustained by the public; and, with respect to the city, declared that he would take the whole loss of it upon himself. These disasters were in some measure counterbalanced by the successes in Britain, under Agricola. This excellent general, having been sent into that country towards the end of Vespasian's reign, showed himself equally expert in quelling the refractory, and civilising those who had formerly submitted to the Roman power. The Ordovices, or inhabitants of North Wales, were the first that were subdued. He then made a descent upon Mona, or the island of Anglesea, which surrendered at discretion. Having thus rendered himself master of the whole country, he took every method to restore discipline to his army, and to introduce some politeness among those whom he had conquered. He exhorted them, both by advice and example, to build temples, theatres, and stately houses. He caused the sons of their nobility to be instructed in the liberal arts; he had them taught the Latin language, and induced them to imitate the Roman modes of dressing and living. Thus, by degrees, this barbarous people began to assume the luxurious manners of their conquerors, and in time even outdid them in all the refinements of sensual pleasure. For the success in Britain, Titus was saluted emperor the fifteenth time; but he did not long survive his honors, being seized with a violent fever, at a little distance from Rome. Perceiving his death approach, he declared that during the whole course of his life he knew but of one action which he repented of; but that action he did not think proper to express. Shortly after he died (not without suspicion of treachery from his brother Domitian, who had long wished to govern), in the forty-first year of his age, having reigned two years two months and twenty days.

**DOMITIAN.**—The love which all ranks of people bore to Titus facilitated the election of his brother Domitian, notwithstanding the ill opinion many had already conceived of him. His ambition was already but too well known, and his pride soon appeared upon his coming to the throne, having declared that he had given the empire to his father and brother, and now received it again as his due. The beginning of his reign was universally acceptable to the people, as he appeared remarkable for clemency, liberality, and justice. He carried his abhorrence of cruelty so far as once to forbid the sacrificing of oxen. His liberality was such that he would not accept of the legacies that were left him by such as had children. His justice was such that he would sit whole days and reverse the partial sentences of the ordinary judges. He was very liberal in repairing the libraries which had been burnt, and recovering copies of such books as had been lost, sending on purpose to Alexandria to transcribe them. But he soon

began to show the natural deformity of his mind. No emperor before him entertained the people with such various and expensive shows. During these diversions he distributed rewards; sitting as president himself, adorned with a purple robe and crown, with the priests of Jupiter and the college of Flavian priests about him. The meanness of his occupations in solitude were a just contrast to his exhibitions in public. He usually spent his hours of retirement in catching flies, and sticking them through with a bodkin. His vices seemed every day to increase with the duration of his reign. His ungrateful treatment of Agricola seemed the first symptom of his natural malevolence. Domitian was always particularly fond of obtaining a military reputation, and therefore jealous of it in others. He had marched some time before into Gaul, upon a pretended expedition against the Catti, a people of Germany; and, without ever seeing the enemy, resolved to have the honor of a triumph upon his return to Rome. For that purpose he purchased a number of slaves, whom he dressed in German habits; and at the head of this miserable procession he entered the city, amidst the apparent acclamations and concealed contempt of all his subjects. The successes, therefore, of Agricola in Britain affected him with an extreme degree of envy. This admirable general routed the Caledonians; overcame Galgacus, the British chief, at the head of 30,000 men; and, afterwards sending out a fleet to scour the coast, first discovered Great Britain to be an island. See SCOTLAND. He likewise discovered and subdued the Orkneys, and thus reduced the whole into a civilised province of the Roman empire. When the account of these successes was brought to Domitian he received it with a seeming pleasure, but real uneasiness. He thought Agricola's rising reputation a reproach upon his own inactivity; and, instead of attempting to emulate, he resolved to suppress the merit of his services. He ordered him, therefore, the external marks of his approbation, and took care that triumphant ornaments, statues, and other honors, should be decreed him; but at the same time he removed him from his command, under a pretence of appointing him to the government of Syria. Agricola surrendered up his government to Sallustius Lucullus, but soon found that Syria was otherwise disposed of. Upon his return to Rome, which was privately and by night, he was coolly received by the emperor; and, dying some time after in retirement, it was supposed that his end was hastened by Domitian's direction. Domitian soon after found the want of so experienced a commander in the many irruptions of the barbarous nations that surrounded the empire. The Sarmatians in Europe, joined with those in Asia, made a formidable invasion: at once destroying a whole legion, and a general of the Romans. The Dacians, under Decebalus their king, made an irruption, and overthrew the Romans in several engagements, so that every season became memorable for some remarkable overthrow. At last, the state making a vigorous exertion of its internal power, the barbarians were repelled, partly by money, which enabled them to make invasions afterwards to greater advantage. But

Domitian was resolved not to lose the honor of a triumph, and took the surname of Germanicus, for his conquest over a people with whom he never contended. In proportion as he merited ridicule, his pride every day demanded greater homage. He would permit his statues to be made only of gold and silver; assumed to himself divine honors; and ordered that all men should treat him with the same appellations which they gave to the divinity. His cruelty was not behind his arrogance: he caused numbers of illustrious senators and others to be put to death upon the most trifling pretences. Sallustius Lucullus, his lieutenant in Britain, was destroyed only for having given his own name to a new kind of lance. Junius Rusticus died for publishing a book in which he commended Thræsa and Priscus, two philosophers who opposed Vespasian's coming to the throne. Such cruelties as these naturally produced rebellion. Lucius Antonius, governor in Upper Germany, assumed the ensigns of imperial dignity. As he was at the head of a formidable army, his success remained long doubtful; but, a sudden overflowing of the Rhine dividing his army, he was set upon at that juncture by Normandus, the emperor's general, and totally routed. Domitian's severity was greatly increased by this success. To discover those who were accomplices with the adverse party, he invented new tortures. During these cruelties, he never pronounced sentence without a preamble full of gentleness and mercy. He was particularly terrible to the senate, the whole body of whom he frequently threatened entirely to extirpate. At one time, he surrounded the senate-house with his troops, to the great consternation of the senators. At another he resolved to amuse himself with their terrors in a different manner. Having invited them to a public entertainment, he received them all very formally at the entrance of his palace, and conducted them into a spacious hall, hung round with black, and illuminated by a few melancholy lamps, that diffused light only sufficient to show the horrors of the place. All around were to be seen nothing but coffins, with the names of each of the senators written upon them, together with other objects of terror, and instruments of execution. While the company beheld all the preparations with silent agony, several men, having their bodies blackened, each with a drawn sword in one hand and a flaming torch in the other, entered the hall, and danced round them. After some time, when the guests expected nothing less than instant death, the doors were set open, and a servant informed them that the emperor gave all the company leave to withdraw. These cruelties were rendered still more odious by his lust and avarice. Frequently, after presiding at an execution, he would retire with the lowest prostitutes, and use the same baths. His avarice, the consequence of his profusion, knew no bounds. He seized upon the estates of all against whom he could find the smallest pretensions. He particularly exacted large sums from the Jews: and was excited against them, not only by avarice, but by jealousy. A prophecy had been long current in the east, that a person of the line of David should rule the world. Where-

upon, this suspicious tyrant commanded all the Jews of the lineage of David to be diligently sought out, and put to death. Two Christians of that line, grandsons of St. Jude the Apostle, were brought before him; but finding them poor, and no way ambitious, he dismissed them, considering them as too mean for his jealousy. Yet his persecution of the Christians was more severe than even that of Nero. By his letters and edicts they were banished and put to death with tortures. The predictions of astrologers also, concerning his death, kept him in the most tormenting disquietude. Every omen and prodigy gave him fresh anxiety. But a period was soon put to this monster's cruelty. Among those whom he at once caressed and suspected was his wife Domitia, whom he had taken from Ælius Lama, her former husband. This woman, however, was become obnoxious to him for having placed her affections upon one Paris, a player; and he resolved to despatch her, with several others. It was his custom to put down the names of all such as he intended to destroy in his tablets. Domitia, fortunately happening to get a sight of them, was struck at finding her own name in the catalogue of those fated to destruction. She showed the fatal list to Norbanus and Petronius, prefects of the prætorian bands, who were also set down; as well as to Stephanus, the comptroller of the household, who joined in the conspiracy. These, after many consultations, fixed on the 18th of September for their attempt. Domitian was apprehensive of that day, and was now more particularly upon his guard. He had some time before secluded himself in the most secret recesses of his palace; and at midnight was so affrighted as to leap out of his bed, inquiring of his attendants what hour it was. Upon their falsely assuring him that it was an hour later than that which he was taught to apprehend, quite transported, as if all danger was past, he prepared to go to the bath. Just then, Parthenius his chamberlain came to inform him that Stephanus desired to speak to him upon an affair of importance. The emperor, having ordered his attendants to retire, Stephanus entered with his left hand in a scarf, which he had worn thus for some days, to conceal a dagger. He began by giving information of a pretended conspiracy, and exhibited a paper in which the particulars were specified. While Domitian was reading the contents, with eager curiosity, Stephanus drew his dagger and struck him in the groin. Domitian caught hold of the assassin, and threw him upon the ground, calling out for assistance. He demanded also his sword; but a boy, running to fetch it, found only the scabbard, for Parthenius had removed the blade. The struggle with Stephanus continued: Domitian still kept him under, and at one time attempted to wrest the dagger from his hand, at another to tear out his eyes. But Parthenius, with his freed man, a gladiator, and two subaltern officers, coming in, ran all furiously upon the emperor, and despatched him. In the mean time, some of the officers of the guard, being alarmed, came to his assistance, but too late; however, they slew Stephanus on the spot.

**NERVA.**—When it was publicly known that Domitian was slain, the joy of the senate was so

great that, being assembled with the utmost haste they began to load his memory with every reproach. His statues were commanded to be taken down; and a decree was made that all his inscriptions should be erased, his name struck out of the registers of fame, and his funeral omitted. The people looked on his death with indifference; the soldiers alone, whom he had enriched by largesses, regretted his death. The senate, therefore, resolved to provide a successor before the army could have an opportunity of appointing one; and Cocceius Nerva was chosen the very day on which the tyrant was slain. Nerva was of an illustrious family, by birth a Spaniard, and above sixty-five years old when called to the throne. He was, at that time, the most remarkable man in Rome, for his virtues, moderation, and respect to the laws. When the senate went to pay him their submissions, he received them with his accustomed humility; while Arius Antonius, his most intimate friend, congratulated him on his accession to the empire; and indeed no emperor had ever shown himself more worthy of the throne; his only fault being that he was too indulgent to his insidious courtiers. However, an excess of indulgence and humanity were faults that Rome could easily pardon: being long accustomed to tyranny, they regarded Nerva's gentle reign with rapture. Upon coming to the throne he solemnly swore that no senator of Rome should be put to death, by his command, during his reign; and conferred great favors upon his particular friends. His liberality was so extensive that he was constrained to sell his gold and silver plate, with other rich moveables, to enable him to continue it. He released the cities of the empire from many severe impositions, which had been laid upon them by Vespasian; took off a rigorous tribute upon carriages; and restored those to their property who had been unjustly dispossessed by Domitian. During his short reign he made several good laws. He prohibited the castration of male children; which had been condemned by his predecessor, but not wholly removed. He put all those slaves to death who had, during the last reign, informed against their masters. He permitted no statues to be erected to honor him, and converted into money such of Domitian's as had been spared by the senate. He sold many rich robes, and much of the splendid furniture of the palace, and retrenched several unreasonable expenses at court. He had so little regard for money, that when Herodes Atticus had found a large treasure, and wrote to him how to dispose of it, he received for answer that he might use it; but the finder, still informing the emperor that it was a fortune too large for a private person, Nerva, admiring his honesty, wrote him that then he might abuse it. A life of such generosity and mildness was not, however, without enemies. Calpurnius Crassus, with some others, formed a dangerous conspiracy to destroy him; but Nerva would use no severity; he rested satisfied with banishing those who were culpable, though the senate were for inflicting more rigorous punishments. The most dangerous insurrection against his interests was from the prætorian bands; who, headed by Cas-

parius Ollianus, insisted upon revenging the late emperor's death. Nerva, whose kindness to good men rendered him still more obnoxious to the vicious, did all in his power to stop the progress of this insurrection; he presented himself to the mutinous soldiers, and, opening his bosom, desired them to strike there, rather than be guilty of so much injustice. The soldiers, however, paid no regard to his remonstrances; but, seizing upon Petronius and Parthenius, slew them in the most ignominious manner; and even compelled the emperor to approve of their sedition, and to make a speech to the people, in which he thanked the cohorts for their fidelity. So disagreeable a constraint upon the emperor's inclinations was, in the end, attended with one good effect, as it caused the adoption of Trajan. Nerva perceived that, in the turbulent disposition of the times, he stood in need of an assistant in the empire, who might contribute to keep the licentious in awe. For this purpose, setting aside all his own relations, he fixed upon Ulpian Trajan, an utter stranger, who was then governor in Upper Germany, to succeed him. He then sent off ambassadors to Cologne, where Trajan resided, intreating his assistance in punishing those from whom he had received such an insult. The adoption of this admirable man, proved so great a curb to the licentiousness of the soldiery that they continued in perfect obedience during the rest of this reign; and Casparius, being sent to him, was either banished or put to death. The adoption of Trajan was the last public act of Nerva. In about three months after, having put himself in a violent passion with one Regulus a senator, he was seized with a fever, of which he soon after died, after a short reign of one year four months and nine days. He was the first foreign emperor who reigned in Rome, and was justly reputed a prince of great generosity and moderation. He is also celebrated for his wisdom, one great instance of which he gave in the choice of his successor.

**TRAJAN.**—Trajan's family was originally from Italy, but he himself was born in Seville in Spain. He very early accompanied his father, who was a general of the Romans, in his expeditions along the Euphrates and the Rhine; and, while yet very young, acquired considerable reputation for military accomplishments. He inured his body to fatigue; he made long marches on foot; and labored to acquire all that skill in war which was necessary for a commander. When he was made general of the army in Lower Germany, which was one of the most considerable employments in the empire, it made no alteration in his way of living; and the commander no way differed from the private tribune, except in his superior wisdom and virtues. The great qualities of his mind were accompanied with all the advantages of person. His appearance was majestic; he was at the middle period of life, being forty-two years old; and possessed a modesty that seemed peculiar to him. Upon the whole, Trajan is distinguished as the greatest and best emperor of Rome. Others may have equalled him in war, and some have been his rivals in clemency and goodness; but he seems the only prince who united these talents, and

VOL. XVIII.

who appears equally to engage our admiration and regard. Upon being informed of the death of Nerva, he prepared to return to Rome, whether he was invited by the united entreaties of the state. He began his march with a discipline that was long unknown in the armies of the empire. The countries through which he passed were neither ravaged nor taxed; and he entered the city, not in a triumphant manner, though he had deserved it often, but on foot, attended by the civil officers of the state, and followed in silence by the soldiers. It is almost unnecessary to enter into a detail of this prince's merits. His application to business, his moderation to his enemies, his modesty in exaltation, his liberality to the deserving, and his frugality in his own expenses, have all been the subject of panegyric among his contemporaries, and the admiration of succeeding ages. Upon giving the prefect of the prætorian band the sword, according to custom, he made use of this remarkable expression, 'Take this sword, and use it, if I have merit, for me; if otherwise, against me.' After which he added, 'That he who gave laws was the first who was bound to observe them.' His failings were his love of women, which, however, never hurried him beyond the bounds of decency; and his passion for war, to which he had been bred up from childhood. The first war he was engaged in after his coming to the throne was with the Dacians, who, during the reign of Domitian, had committed numberless ravages upon the provinces. He raised a powerful army and marched rapidly into those barbarous countries, where he was vigorously opposed by Decebalus, the Dacian king, who long withstood his boldest efforts; but was at last entirely reduced, and his kingdom made a Roman province. On his return to Rome, he entered the city in triumph; and the rejoicings for his victories lasted 120 days. Having thus given peace and prosperity to the empire, Trajan continued his reign, loved, honored, and almost adored by his subjects. He adorned the city with public buildings; freed it from such men as lived by their vices; entertained persons of merit with the utmost familiarity; and so little feared his enemies that he could scarcely believe he had any. It had been happy for this great prince's memory if he had shown equal clemency to all his subjects; but, about the ninth year of his reign, he was persuaded to look upon the Christians with a suspicious eye. The veneration which he professed for the Pagan religion led him to oppose every innovation, and the progress of Christianity alarmed him. A law had been passed in which all Heterie, or societies dissenting from the established religion, were considered as illegal, and as nurseries of sedition. Under this law, the Christians were persecuted in all parts of the empire. Great numbers of them were put to death, as well by popular tumults as by edicts and judicial proceedings. At length Trajan receiving from Pliny, the proconsul in Bithynia, his celebrated accounts of the innocence and simplicity of the Christians, he suspended their punishments. But a total stop was put to them upon Tiberianus, the governor of Palestine's sending him word that he was wearied out with executing

3 C

the laws against the Galileans, who crowded to execution in such multitudes that he was at a loss how to proceed. Upon this information, the emperor gave orders that the Christians should not be sought after; but if any offered themselves, they should suffer. Thus the rage of persecution ceased, and the emperor turned the force of his arms against the Armenians and Parthians, who began to throw off all submission to Rome. While he was employed in these wars, there was a dreadful insurrection of the Jews, in all parts of the empire. This wretched people ever expecting some signal deliverer, took the advantage of Trajan's absence to massacre numbers of the Greeks and Romans. This began in Cyrene, a Roman province in Africa; thence extended to Egypt, and next to the island of Cyprus. These places they in a manner dispeopled. Their barbarities were such, it is said, that they ate the flesh of their enemies, wore their skins, sawed them asunder, cast them to wild beasts, made them kill each other, and studied new torments to destroy them. But these cruelties were soon reversed: the governors of the respective provinces, making head against their tumultuous fury, treated them with a retaliation of cruelty, and put them to death, not as human beings, but as wild beasts. As the Jews had practised their cruelties in Cyprus particularly, a law was enacted, by which it was made criminal for any Jew to set foot on the island. During these bloody transactions, Trajan was prosecuting his successes in the east. His first march was into Armenia, the king of which country had disclaimed all alliance with Rome, and received the ensigns of royalty and dominion from the monarch of Parthia. However, upon the news of Trajan's expedition, he abandoned his country to the invaders; while most of his governors and nobility came submissively to the emperor, acknowledging themselves his subjects and making him the most costly presents. Having thus taken possession of the country, and gotten the king into his power, he marched into Parthia; and, first entering the opulent province of Mesopotamia, reduced it to a Roman province. Thence he went against the Parthians, marching on foot at the head of his army; crossing the rivers, and conforming to all the severities of discipline imposed on the meanest soldier. He now conquered Syria, Chaldea, and the famous city of Babylon. Here, attempting to cross the Euphrates, he was opposed by the enemy, who were resolved to stop his passage: but he secretly caused boats to be made upon the adjoining mountains; and, bringing them to the water side, passed his army with great expedition, but not without great slaughter on both sides. Thence he traversed tracts of country which had never before been invaded by a Roman army, and pursued the march of Alexander the Great in this direction. Having passed the Tigris, he advanced to the city Ctesiphon, which he took, and opened a passage into Persia. After subduing all the country on the Tigris, he marched south to the Persian Gulf, where he subdued a monarch possessed of a considerable island made by the divided streams of that river. Here, winter coming on, he was in danger of losing the

greatest part of his army. He therefore, with indefatigable pains, fitted out a fleet, and, sailing down the gulph, entered the Indian Ocean, conquering, even to the Indies, and subduing a part of them to the Roman empire. Prevented from pursuing further conquests by the revolt of many of the provinces he had already subdued, and by the scarcity of provisions, increasing age also contributing to damp the ardor of his enterprise, he now returned along the Persian Gulf, and sending the senate an account of the nations he had conquered, the names of which alone composed a long catalogue, he prepared to punish those which had revolted. He began by laying the famous city of Edessa, in Mesopotamia, in ashes; and soon not only retook such places as had thrown off the Roman yoke, but made himself master of the most fertile kingdoms of all Asia. In this train of successes he scarcely met with a repulse, except before the city Atræ, in the deserts of Arabia. He finally resolved to give a master to the countries he had subdued. With this resolution he once more repaired to Ctesiphon, in Persia; and there, with great ceremony, crowned Parthaspates king of Parthia, to the great joy of all his subjects. He established another king also over Albania, near the Caspian. Then, placing governors and lieutenants in other provinces, he resolved to return to Rome in a more magnificent manner than any of his predecessors. He accordingly left Adrian general in the east; and continued his journey towards the capital, where the most magnificent preparations were made for his arrival. He had not got, however, farther than the province of Cilicia, when he found himself too weak to proceed. He therefore caused himself to be carried on ship-board to the city Seleucia, where he died of apoplexy. During his indisposition, his wife Plotina constantly attended him, and, knowing his dislike to Adrian, forged the will by which he succeeded. Trajan died in the sixty-third year of his age, after a reign of nineteen years, six months, and fifteen days. How highly he was esteemed by his subjects appears by their manner of blessing his successors, wishing the fortune of Augustus and the goodness of Trajan. His military virtues, however, produced no real advantages to his country; and all his conquests disappeared, when the power was withdrawn that enforced them.

ADRIAN.—Adrian was by descent a Spaniard, and his ancestors were of the same city where Trajan was born. He was nephew to Trajan, and married to Sabina his grand-niece. When Trajan was adopted by Nerva, Adrian was a tribune of the army in Mœsia, and was sent by the troops to congratulate the emperor on his advancement. His brother-in-law, who desired to congratulate Trajan himself, supplied Adrian with a carriage that broke down on the way: but Adrian was resolved to lose no time, and performed the rest of the journey on foot. This assiduity was very pleasing to the emperor; but he disliked Adrian for other reasons. He was expensive, involved in debt, inconstant, capricious and envious. These faults, in Trajan's opinion, could not be compensated either by his learning or his talents. His great skill in the

Greek and Latin languages, his intimate acquaintance with the laws of his country and the philosophy of the times, were no inducements to Trajan: who, being bred a soldier, wished a military man to succeed him, and therefore would not appoint a successor. His death, therefore, was concealed for some time by Plotina his widow, till Adrian had sounded the inclinations of the army, and found them firm in his interests. They then produced a forged instrument, importing that Adrian was adopted to succeed in the empire. By this artifice he was elected by all orders of the state, though then general at Antioch. Adrian's first care was to write to the senate, excusing himself for assuming the empire without their previous approbation; imputing it to the hasty zeal of the army. He then began to pursue a course quite opposite to that of Trajan, declining war, and promoting the arts of peace. He was satisfied with preserving the limits of the empire, and no way ambitious of extensive conquest. He therefore abandoned all the conquests which Trajan had made, judging them to be of no advantage to the empire; and made the Euphrates its boundary, placing the legions along its banks to prevent the incursions of the enemy. Having thus settled the affairs of the east, and leaving Severus governor of Syria, he took his journey by land to Rome, sending the ashes of Trajan thither by sea. Upon his approach to the city, he was informed of a magnificent triumph that was preparing for him; but this he modestly declined, desiring that these honors might be paid to Trajan's memory. In consequence a most superb triumph was decreed, in which Trajan's statue was carried as a principal figure in the procession, who is thus said to have been the only man that ever triumphed after he was dead! His ashes were placed in a golden urn, upon the top of a column 140 feet high. On this were engraven the particulars of all his exploits in basso-relievo, a work of immense labor, still remaining. These testimonies of respect to the memory of his predecessor did great honor to the heart of Adrian. His virtues, however, were contrasted by a strange mixture of vices. He wanted strength of mind to preserve his general rectitude of character. As an emperor, however, his conduct was most admirable, as all his public transactions appear dictated by the soundest policy, and the most disinterested wisdom. See **ADRIAN**.

**ANTONINUS PIUS AND ANTONINUS PHILOSOPHUS.**—Adrian was succeeded by Marcus Antoninus, afterwards surnamed the Pious, whom he had adopted some time before his death. See **ANTONINUS PIUS**. From the beginning of his reign we may date the decline of the Roman empire. From the time of Cæsar to that of Trajan scarcely any of the emperors had either abilities or inclination to extend the limits of the empire, or even to defend it against the barbarous nations who surrounded it. During all this space only some inconsiderable provinces of the north of Italy, and part of the island of Britain, had been subjugated. However, as yet, nothing was lost; but the degeneracy and corruption of the people had sown those seeds of dissolution which the empire quickly began to feel. The disorders

were grown to such a height that even Trajan himself could not cure them. Indeed his eastern conquests could scarcely have been preserved though the republic had been existing in all its glory. Dacia, being nearer to the centre of government, was more easily preserved; and remained long subject to Rome. During the twenty-three years of the reign of Antoninus few remarkable events happened. Historians are excessive in their praises of his justice, generosity, and other virtues, both public and private. He put a stop to the persecution of the Christians, and reduced the Brigantes, a tribe of Britons, who had revolted. However, during his reign, several calamities befel the empire. The Tiber, overflowing its banks, laid the lower part of Rome under water. The inundation was followed by a fire, and this by a famine, which swept off great numbers, though the emperor took the utmost care to supply the city from the most distant provinces. At the same time the cities of Narbonne in Gaul, and Antioch in Syria, with the great square in Carthage, were destroyed by fire; however the emperor soon restored them. He died in the year 163, much lamented by his subjects, and was succeeded by Marcus Aurelius, surnamed the Philosopher, whom he had adopted towards the latter end of his reign. For the transactions of this emperor see **ANTONINUS PHILOSOPHUS**. Nerva, Trajan, Adrian, and the Antonines, are stiled by historians the five good emperors.

**COMMODUS.**—After the death of Marcus Aurelius his son Commodus succeeded to the imperial throne without opposition. He was in every respect unworthy of his father, and was generally believed to have been the son, not of Marcus Aurelius, but of a celebrated gladiator, with whom the empress Faustina was said to be intimate. According to Mr. Gibbon, however, 'Commodus was not, as has been represented, a tiger born with an insatiate thirst of human blood, and capable, from his infancy, of the most inhuman actions. Nature had formed him of a weak, rather than a wicked disposition. His simplicity and timidity rendered him the slave of his attendants, who gradually corrupted his mind. His cruelty which at first obeyed the dictates of others degenerated into habit, and at length became the ruling passion of his soul.' But it is certain that the actions of this emperor were flagitious almost beyond a parallel. Many strange instances of his cruelty are related by the ancients. He is said to have cut asunder a corpulent man whom he saw walking along the street; partly to try his own strength, in which he excelled; and partly out of curiosity, to see his entrails drop out at once. He took pleasure in cutting off one of the feet, and putting out one of the eyes, of such as he met in his rambles through the city; telling the former, after he had thus maimed them, that now they belonged to the nation *Monopodii* one-footed; and the latter, that they were now become *Luscinii*, one-eyed. Some he murdered because they were negligently dressed; others because they seemed to be trimmed with too much nicety. He pretended to great skill in surgery, especially at letting blood: but sometimes, instead of curing those

whom he visited, or who were prevailed upon to recur to him, he cut off, by way of diversion, their ears and noses. His lewdness and debaucheries were equally remarkable. He is said to have been exceedingly well skilled in archery, and to have performed incredible feats in that art; to have run an elephant through with his spear, and to have killed in the amphitheatre 100 lions, one after another, each at one blow. He entered the lists with the common gladiators, and came off conqueror 735 times; whence he subscribed himself the conqueror of 1000 gladiators. The public transactions of this reign were few. This emperor concluded a peace with the Marcomanni, Quadi, &c., and promised to abandon all the castles and fortresses held by the Romans in their country, excepting such as were within five miles of the Danube. With the other German nations whom his father had reduced, he concluded a very dishonorable peace; nay, of some he purchased it with money. Soon after his return to Rome his sister Lucilla, perceiving that he was universally abhorred for his cruelty, formed a conspiracy against his life. Among the conspirators were many senators. It was agreed that they should fall upon the emperor while he was going to the amphitheatre through a narrow and dark passage; and that Claudius Pompeianus, to whom Lucilla had betrothed her daughter, should give the first blow. But he, instead of striking at once, showed him the naked dagger, and cried out, 'This present the senate sends you:' so that the guards had time to rescue the emperor, and to seize the conspirators, who were put to death. Commodus now banished his sister to the island of Capree, where he soon after caused her to be murdered. His favorite minister was one Perennis; who in cruelty seems to have been nothing inferior to those of the most tyrannical emperors. During the first part of the reign of Commodus he ruled with an absolute sway; but at last was torn in pieces by the enraged soldiery. He was succeeded by a freed man named Cleander; and the new minister abused his power more flagrantly than even his predecessor. All things were openly set to sale: offices, provinces, public revenues, justice, and the lives of men both innocent and guilty. The minister, who ruled the emperor without control, infused such terrors into his mind that he changed the captains of his guards almost continually. One Niger enjoyed the dignity only six hours; another only five days; and others a still shorter space. Most of those officers lost their lives with their employments; being accused of treason by Cleander, who continually solicited, and at last obtained, that important post. A. D. 187 happened a remarkable revolt. One Maternus, a common soldier, having fled from his colors, and, being joined by many other deserters, grew in a short time so powerful that he over-ran and plundered great part of Gaul and Spain; stormed the strongest cities; and struck the emperor and people of Rome with such terror that troops were raised, and armies despatched against them. Pescennius Niger was sent against him in Gaul, where he became very intimate with Severus, then governor of Lyons, who wrote a letter to the emperor, commending the prudent

and gallant behaviour of Niger in pursuing the rebels. Maternus, being reduced to great straits, divided his men into several small bands, and marched them by different roads into Italy, with intent to murder the emperor during the festival of Cybele, and to seize upon the empire. They all arrived at Rome undiscovered; and several of his men had already mixed with the emperor's guards, when others of his own party betrayed him. He was immediately seized and executed; and his death put an end to the disturbances which some of his followers had begun to raise in other provinces. In the same year broke out the most dreadful plague, says Dio Cassius, that had been known. It lasted two or three years; and raged with the greatest violence at Rome, where it often carried off 2000 persons a day. The following year a dreadful fire, which consumed a great part of the city, was kindled by lightning; and a dreadful famine followed, occasioned, it is said, by Cleander, who, having in view nothing less than the sovereignty itself, bought up underhand all the corn, to raise the price of it, and gain the affections of the soldiers and people by distributing it among them. Others say that Papirius Dionysius, whose duty it was to supply the city with provisions, contributed towards the famine, to make the people rise against Cleander. The populace ascribed all their calamities to this hated minister; and one day, while they were celebrating the Circensian games, a troop of children, having at their head a young woman of an extraordinary stature and fierce aspect, entering the circus, began to utter many bitter invectives and dreadful curses against Cleander; which being answered by the people in the same style, the mob rose, and flew to the place where Cleander resided with the emperor, demanding his head. Hereupon Cleander ordered the prætorian cavalry to charge the multitude; which they did, driving them with great slaughter into the city. But the populace, discharging showers of stones, bricks, &c., from the tops of houses and windows, and the city guards at the same time taking part with the people, the prætorian horse were put to flight; nor was the slaughter ended till the emperor caused the head of Cleander to be struck off and thrown out to the enraged populace. The emperor himself did not long survive Cleander; being cut off by a conspiracy of Marcia his favorite concubine, Lætus captain of the guards, and Eclectus his chamberlain.

HELVIVS PERTINAX.—No sooner was the death of Commodus known than the senate assembled, and, declaring him a public enemy, ordered his statues to be broken to pieces, his name to be rased out of all public inscriptions, and his body to be dragged through the streets and thrown into the Tiber. But Helvius Pertinax, whom the conspirators had previously designed for the empire, and who had already assumed it, prevented this last outrage by telling the senators that Commodus was already buried. This extraordinary personage had already passed through many changes of fortune. He was the son of an enfranchised slave called Ælius, who gave him as much learning as to qualify him for a shopkeeper. He then became a schoolmaster

afterwards studied the law, and then became a soldier; in which station his behaviour raised him to be captain of a cohort against the Parthians. After this he went through the usual gradation of military preferment in Britain and Mœsia, until he became the commander of a legion under Aurelius. In this station he performed such services against the barbarians that he was made consul, and successively governor of Dacia, Syria, and Asia Minor. In the reign of Commodus he was banished; but soon after recalled, and sent into Britain to reform the abuses in the army. In this employment he was opposed by a sedition among the legions, and left for dead among many that were slain. However he got over this danger, severely punished the mutineers, and established discipline among the troops he was sent to command. Thence he was removed into Africa, where the sedition of the soldiers had like to have been again fatal to him. Removing from Africa, and fatigued with an active life, he betook himself to retirement: but Commodus made him prefect of the city; which office he possessed when the conspirators fixed upon him to be emperor. His being advanced by Commodus only made him dread becoming an object of his suspicion. When, therefore, the conspirators repaired to his house by night he considered them as messengers of death; and, upon Lætus entering his apartment, Pertinax said that he had long expected to end his life in that manner, and wondered that the emperor had deferred it so long; and it was not until he was urged that he would accept of the empire. Being carried to the camp he was immediately proclaimed: soon after the citizens and senate consented; the joy for the election of a new sovereign not being superior to that for the death of the old. The provinces followed the example of Rome; so that he began his reign with universal satisfaction in the sixty-eighth year of his age. Nothing could exceed the general wisdom and justice of this monarch's reign. He punished all those who had served to corrupt the late emperor, and disposed of his private possessions to public uses. He attempted to restrain the licentiousness of the prætorian hands, and put a stop to the injuries and insolences they committed against the people; sold most of the buffoons and jesters of Commodus's slaves; frequented the senate as often as it sat; and never refused an audience even to the meanest of the people. His success in foreign affairs was equal to his internal policy. When the barbarous nations abroad had certain intelligence that he was emperor they immediately laid down their arms, well knowing what they were to expect from so experienced a commander. His great fault was avarice; and that hastened his ruin. The prætorian guards, whose manners he had attempted to reform, having been long corrupted by the profusion of their former monarchs, began to hate him for his parsimony. They therefore resolved to dethrone him; and for that purpose declared Maternus, an ancient senator, emperor. Maternus, however, was too just to the merits of Pertinax to concur in their designs, and fled out of the city. They then nominated Falco, ano-

ther senator; whom the senate itself would have ordered for execution had not Pertinax interposed. The prætorians then resolved to seize upon the emperor and empire at once. They accordingly, in a tumultuous manner, marched through the streets of Rome, and entered the palace without opposition. The greatest part of the emperor's attendants forsook him; whilst those who remained earnestly entreated him to fly to the body of the people. However he rejected their advice; declaring that it was unworthy of his imperial dignity, and all his past actions, to save himself by flight. Having thus resolved to face the rebels, he had some hopes that his presence would awe them. But his virtues and dignity availed little against a tumultuous rabble, nursed up in vice, and the ministers of former tyranny. Not only the emperor, but Eclectus, and some of his attendants, who attempted to defend him, were slain. Thus, after an excellent reign of three months, Pertinax fell a sacrifice to the licentious fury of the army: from his adventures he was called the 'tennis-ball of Fortune.' The soldiers, having committed this outrage, retired with great precipitation; and, getting out of the city, quickly fortified their camp, expecting to be attacked by the citizens. Two days having passed without any attempt of this kind, they became more insolent; and, to make use of the power they possessed, made proclamation that they would sell the empire to any who would purchase it at the highest price. In consequence of this infamous proclamation only two bidders were found, viz. Sulpicianus and Didius Julianus; the former præfect of the city, and son-in-law to Pertinax; the latter a great lawyer, and the wealthiest man in the city; both consular persons. Didius was sitting with some friends at dinner when the proclamation was published; and, being charmed with the prospect of unbounded power, immediately rose from the table and hastened to the camp. Sulpicianus was there before him; but, as he had more promises than treasure to bestow, the offers of Didius, who produced immense sums of ready money, prevailed.

JULIAN I.—Didius Julianus was received into the camp by a ladder, and they instantly swore to obey him as emperor. From the camp he was attended by his electors into the city; the whole body of his guards, which consisted of 10,000 men, ranged around him in such order as if they had prepared for battle. The citizens, however, refused to confirm his election; and cursed him as he passed. Upon being conducted to the senate house, he addressed the few senators that were present in a very laconic speech: 'Fathers, you want an emperor; and I am the fittest person you can choose.' Even this was unnecessary, as the senate durst not refuse their approbation. His speech being backed by the army, to whom he had given about a million of our money, succeeded. The choice of the soldiers was confirmed by the senate, and Didius was acknowledged emperor, in the fifty-seventh year of his age. It should seem by this weak monarch's conduct, when seated on the throne, that he thought the government of an empire rather a pleasure than a toil. He gave him-



self up to ease and inactivity, utterly regardless of the duties of his station. He was mild and gentle indeed; but that avarice, by which he became opulent, still followed him in his exaltation; so that the very soldiers who elected him began to detest him. The people also, against whose consent he was chosen, were no less inimical. Whenever he issued from his palace they poured forth their imprecations against him; crying out that he was a thief and had stolen the empire. Didius, however, patiently bore it all. While Julian was thus contemptuously treated at home, two valiant generals in different parts of the empire disclaimed his authority, and resolved to seize the throne. These were, Pescennius Niger, governor of Syria; and Septimius Severus, commander of the German legion. Niger was beloved by the people for his clemency and valor; and his proposing Pertinax for his model, and resolving to revenge his death, gained him universal esteem. He easily induced his army in Syria to proclaim him emperor; and his title was soon after acknowledged by all the kings and potentates in Asia, who sent their ambassadors to him. The pleasure of being thus treated as a monarch, retarded his endeavours to secure his title. Satisfied with the homage of those about him, he neglected the opportunity of suppressing his rivals; and gave himself up to luxury and feasting at Antioch. The conduct of Severus, an African by birth, was very different. Being proclaimed by his army, he began by promising to revenge the death of Pertinax, and took upon him his name. He next secured all the strong places in his province; and then resolved to march with his whole force directly to Rome. In the mean time Didius Julianus, who disregarded the attempts of Niger, was greatly alarmed at those of Severus. He first procured the senate to proclaim him a traitor. He then attempted to make the necessary provisions to oppose him, but found nothing but disappointment. The cohorts that elected him were enervated by vice and luxury; the people detested his cause; and the cities of Italy had long been disused to the arts of war. The unfortunate Didius, unequal to the task of empire, and confounded with the multiplicity of councils, could take no other resolution out that of awaiting his rival's coming to Rome. Accordingly, soon after being informed of his approach, he obtained the consent of the senate to send his ambassadors, offering to make him a partner of the empire. But Severus rejected this offer, conscious of his own strength, and of the weakness of the proposer. The senate soon appeared of the same sentiments; alleging that he who could not defend the empire was not worthy to govern it. Didius vainly endeavoured to reduce them to their duty, first by entreaties, and then by threats; but these served only to hasten his destruction. The senate being called together, as was formerly practised by the consuls, they unanimously decreed that Severus should be proclaimed. They then commanded Didius to be slain, and sent assassins to the palace, where they found him disarmed, and weeping among a few friends that still adhered to his interest. When they began to prepare for their

fatal errand he expostulated with them, demanding what crime he had committed? The executioners, neither able nor willing to enter into the merits of the cause, led him into the secret baths of the palace, and, obliging him to stretch his neck forwards, struck off his head, and placed it up in those courts where he had formerly pleaded with great success.

SEVERUS.—The senate then sent ambassadors to Severus, yielding him obedience, granting him the ensigns and the usual titles of empire, and informing him of the death of Didius. Severus, who was now about forty-seven years of age, received them with all proper respect; and, entertaining them honorably, continued his march towards Rome. As he came near the city, his first exertion of power was to have all the prætorian soldiers who had sold the empire come forth unarmed to meet him. These, though sensible of their danger, had no other resource but compliance; and accordingly came forward with branches of laurel to welcome his approach. Severus soon showed how little capable their submission was to atone for their past offences: after upbraiding them with their crimes, he commanded them to be stripped of their military habits, deprived of the honor of soldiers, and banished 100 miles from Rome. He then entered the city in a military manner, took possession of the palace, and promised the senate to conduct himself with clemency and justice. But, though he united great vigor with the most refined policy, his African cunning was not relished. He is celebrated for wit, learning, and prudence; but blamed for infidelity and cruelty. He seemed equally disposed to the greatest acts of virtue and the most bloody severities. He seized all the children of such as had employment or authority in the east, and detained them as pledges for their fathers' loyalty. He next supplied the city with corn; and then with all possible expedition marched against Niger, who was still considered as emperor of the east. One chief obstacle to his march was, the leaving behind him Clodius Albinus, commander of the legions in Britain, whom he wished to secure in his interests. For this end he gave him hopes of succeeding to the empire; insinuating that he himself was declining, and his children were but infants. He wrote in the same style to the senate, gave him the title of Cæsar, and ordered money to be coined with his image. These artifices serving to lull Albinus into false security, Severus marched against Niger with all his forces. After some undecisive conflicts, the last great battle fought between these extraordinary men was upon the plains of Issus, on the very spot where Alexander had formerly conquered Darius. The neighbouring mountains were covered with vast numbers of people, who wished to be spectators of an engagement that was to determine the empire of the world. Severus was conqueror; and Niger's head, being struck off, was insultingly carried through the camp on the point of a lance. This victory secured Severus in the throne. But the Partnians, Persians, and some neighbouring nations took up arms, under pretence of vindicating Niger's cause. The emperor marched against them in person, had many

engagements with them, and obtained such signal victories over them as enlarged the empire, and established peace in the east. Severus now turned his views against Albinus, whom he resolved to destroy. For this purpose he sent assassins into Britain, under a pretence of bringing him letters, but in reality to despatch him. Albinus, apprised of their designs, resorted to open force, and proclaimed himself emperor. Nor was he without a powerful army to support his pretensions; of which Severus being sensible, bent his whole force to oppose him. From the east he continued his course across the straits of Byzantium, into the most western parts of Europe, without intermission. Albinus went over to meet him with his forces into Gaul; the campaign on both sides was carried on with great vigor. Fortune seemed variable; but at last a decisive engagement was fought, one of the most desperate recorded in the Roman history. It lasted from morning till night, without any seeming advantage on either side; at length the troops of Severus began to fly, and, he himself happening to fall from his horse, the army of Albinus cried out, Victory. But the engagement was renewed with vigor by Lætus, one of Severus's commanders, who came up with a body of reserve, designing to destroy both parties and make himself emperor. This attempt turned out entirely to the advantage of Severus. He charged with such fury and exactness that he soon obtained the victory; and, pursuing them into the city of Lyons, took Albinus prisoner, and cut off his head; treating his dead body with insults that could only flow from a mean and revengeful temper. All the senators who were slain in battle he ordered to be quartered, and such as were taken alive were immediately executed. Having thus secured himself in the empire, upon his return to Rome he loaded his soldiers with rewards and honors, giving them such privileges as strengthened his own power, while they destroyed that of the state; for the soldiers, who had hitherto showed the strongest inclination to an abuse of power, were now made arbiters of the fate of emperors. Being thus secure of his army, he resolved to give way to his natural turn for conquest, and to oppose his arms against the Parthians, who were then invading the frontiers. Having therefore previously given the government of domestic policy to one Plautianus, a favorite, to whose daughter he married his son Caracalla, he set out for the east, and prosecuted the war with his usual expedition and success. He forced submission from the king of Armenia, destroyed several cities in Arabia Felix, landed on the Parthian coasts, took and plundered the famous city Ctesiphon, marched back through Palestine and Egypt, and at length returned to Rome in triumph. During this interval Plautianus, who was left to direct the affairs of Rome, began to think of aspiring to the empire himself. Upon the emperor's return he employed a tribune of the prætorian cohorts to assassinate him and his son Caracalla. The tribune informed Severus of his favorite's treachery. He at first received it as an improbable story, and as the artifice of some who envied his favorite. But he was at last persuaded to permit the tribune to

conduct Plautianus to the emperor's apartments. The tribune went and amused him with a pretended account of his killing the emperor and his son, desiring him, if he wished to see them dead, to come with him to the palace. As Plautianus ardently desired their deaths, he gave credit to this relation; and, following the tribune, he was conducted at midnight into the innermost recesses of the palace. But what must have been his disappointment, when, instead of finding the emperor murdered, as he expected, he beheld the room lighted up with torches, and Severus, surrounded by his friends, prepared in array to receive him. Being asked by the emperor, with a stern countenance, what had brought him there at that unseasonable time, he was utterly confounded, and, not knowing what excuse to make, confessed the whole, entreating forgiveness. The emperor seemed inclined to pardon him, but Caracalla spurned him away in the midst of his supplications, and with his sword ran him through the body. After this Severus spent a considerable time in visiting some cities in Italy, permitting none of his officers to sell places of trust or dignity, and distributing justice with the strictest impartiality. He took such an exact order in managing his exchequer that, notwithstanding his great expenses, he left more money behind him than any of his predecessors. His armies also were kept upon the most respectable footing; so that he feared no invasion. Being equally attentive to the preservation of all parts of the empire, he resolved to make his last expedition into Britain, where the Romans were in danger of being destroyed. Wherefore, after appointing his sons Caracalla and Geta joint successors in the empire, and taking them with him, he landed in Britain, to the great terror of such as had incurred his resentment. Upon his progress into the country, he left Geta in the south part of the province, which had continued in obedience, and marched with Caracalla against the Caledonians. In this expedition his army suffered prodigious hardships in pursuing the enemy; they were obliged to hew their way through intricate forests, to drain extensive marshes, and form bridges over rapid rivers: so that he lost 50,000 men by fatigue and sickness. However, he supported all these inconveniences with the greatest bravery; and prosecuted his successes with such vigor that he compelled the enemy to sue for peace, which, it is said, they obtained upon the surrender of a considerable part of their country. Having made peace, and built his celebrated wall, he retired to York; where, partly through age and fatigue, partly through grief at the vices of Caracalla, he found himself fast declining, having already lost the use of his feet. To add to his distress, he was told that the soldiers had revolted, and declared his son emperor. In this exigence he seemed once more to recal his natural vigor; he got himself immediately put into his litter, and commanded the new emperor, with the tribunes and centurions, to be brought before him. Though all were willing to court the favor of the young emperor, such was the authority of Severus that none dared to disobey. They appeared before him confounded and trembling, and implored pardon upon their knees. Upon

which, putting his hand to his head, he cried out, 'Know that it is the head that governs, and not the feet.' However soon perceiving his disorder to increase, and knowing that he could not outlive it, he called for poison; which being refused him, he loaded his stomach with food, which, not being able to digest, soon brought him to his end, in the fifty-sixth year of his age, after an active though cruel reign of about eighteen years.

CARACALLA.—Caracalla and Geta, being acknowledged as emperors by the army, began to show a mutual hatred to each other even before their arrival at Rome. Their only agreement was, in resolving to deify Severus their father; but soon after each sought to attach the senate and army to his own interest. They were of very opposite dispositions; Caracalla was fierce and cruel to an extreme; Geta was mild and merciful; so that the people soon found the dangerous effects of being governed by two princes of equal power and contrary inclinations. But this opposition was short; for Caracalla, resolved to govern alone, furiously entered Geta's apartment, and, followed by ruffians, slew him in his mother's arms. Having committed this detestable murder, he issued with great haste from the palace, crying out, that his brother would have slain him; and that he was obliged, in self-defence, to retaliate the intended injury. He then took refuge among the prætorian cohorts, and in a pathetic tone began to implore their assistance, still making the same excuse for his conduct. To this he added a much more prevailing argument, promising to bestow upon them the largesses usually given upon the election of new emperors, and distributing among them almost all the treasures which had been amassed by his father. By such persuasives the soldiers did not hesitate to proclaim him sole emperor, and to stigmatise the memory of his brother Geta as a traitor. The senators were induced, through favor or fear, to approve what had been done by the army; Caracalla wept for the death of his brother whom he had slain; and, to carry his hypocrisy to the utmost extreme, ordered him to be adored as a god. After this he continued to mark his course with blood. Whatever was done by Domitian or Nero fell short of this monster's barbarities. Lætus, who first advised him to murder his brother, was the first who fell a sacrifice to his jealousy. His own wife Plautina followed. Papilian, the renowned civilian, was beheaded for refusing to write in vindication of his cruelty; answering the emperor's request, by observing, 'That it was much easier to commit a parricide than to defend it.' He commanded all governors to be slain whom his brother had appointed; and destroyed no less than 2000 persons who had adhered to the party. Whole nights were spent in the execution of his bloody decrees; and the dead bodies of people of all ranks were carried out of the city in carts, where they were burnt in heaps, without any of the ceremonies of a funeral. He once ordered his soldiers to set upon a crowded audience in the theatre, only for discountenancing a charioteer whom he happened to favor. Perceiving himself hated by the people, he said that he could insure

his own safety, so that he neither valued their reproaches, nor feared their hatred. This safety which he so much trusted in was the protection of his soldiers. He had exhausted the treasury, drained the provinces, and committed a thousand acts of rapacity, merely to keep them stedfast in his interests; and, being disposed to trust himself with them particularly, he resolved to lead them upon a visit through all the provinces of the empire. He first went into Germany; where he dressed himself in the habit of the country. Thence he travelled into Macedonia, where he pretended to be a great admirer of Alexander the Great; and, among other extravagancies, caused a statue of that monarch to be made with two faces; one of which resembled Alexander and the other himself. He called himself Alexander; walked as he was told that monarch had walked; and, like him, bent his head to one shoulder. Shortly after, arriving at Lesser Asia and the ruins of Troy, as he was viewing the tomb of Achilles, he took it into his head to resemble that hero; and, one of his freed men happening to die at that time, he used the same ceremonies that were performed at the tomb of Patroclus. Passing thence into Egypt, he massacred in the most terrible manner the inhabitants of Alexandria, on account of the satires they composed on him. See ALEXANDRIA. Going thence into Syria, he invited Artabanus, king of Parthia to a conference, which he ended by a most infernal piece of treachery. Upon his return towards Rome, his vices seemed inexhaustible; for, having been guilty of parricide, he now resolved to marry the mother of Geta whom he had slain. One day seeing her drop her veil, which disclosed her naked bosom, which was extremely beautiful, he told her that he would possess those charms if it were lawful. To this unnatural request the worthless woman answered that he might enjoy all things who possessed all. Whereupon, setting aside all respect for his deceased father, he celebrated his nuptials with her in public, totally disregarding the censures and sarcasms of mankind. However, though he disregarded shame, he was not insensible to fear. He was continually consulting astrologers what death he should die. He sent one of his confidants, named Maternianus, to consult all the astrologers in the city concerning his end. Maternianus considered this as a proper time to get rid of Macrinus, the emperor's commander in Mesopotamia. He therefore informed him by letter, as if from the astrologers, that Macrinus had a design against his life; and advised him to put the conspirator to death. This letter was sent sealed, and made up, amongst many others, to be delivered to the emperor, as he was preparing for a chariot-race. However he gave the packet to Macrinus to read over, and to inform him of the contents when at leisure. In perusing these letters, when Macrinus came to that which regarded himself, he was filled with surprise and terror. He reserved the letter to himself, and acquainted the emperor with the substance of the rest. He then set about the most probable means of compassing his death. He applied to one Martialis, a man of great strength, and a centurion of the guards, who hated the emperor

on account of the death of a brother, whom Caracalla had ordered to be slain. Macrinus exhorted him to revenge his brother's death by killing the tyrant. Martialis readily undertook the dangerous task. Accordingly, as Caracalla was riding out one day near a city called Carræ, he withdrew privately, upon a natural occasion, with only one page to hold his horse. This was the opportunity Martialis had long and ardently desired; and therefore, running to him as if he had been called, he stabbed the emperor in the back, so that he died immediately. Martialis returned to his troop; but, retiring, he endeavored to secure himself by flight. But his companions missing him, and the page telling what had been done, he was pursued by the German horse and cut in pieces. During the reign of this execrable tyrant, which continued six years, the empire was every day declining; the soldiers were entirely masters of every election; and, as there were various armies in different parts, so there were as many interests all opposite to each other. Caracalla, by satisfying their most unreasonable appetites, destroyed all discipline among them, and all subordination in the state.

**MACRINUS.**—The soldiers, after a suspense of two days, fixed upon Macrinus, who took care to conceal his being privy to Caracalla's murder. The senate confirmed their choice, and likewise that of his son Diadumenus, whom he took as a partner. Macrinus was fifty-three years old when he entered upon the government. He was of obscure parentage; some say by birth a Moor, who, by the mere rotation of office, being first made præfect of the prætorian bands, was now, by treason and accident, called to fill the throne. Little is recorded of this emperor, except his engaging in a bloody, though undecided, battle with Artabanus king of Parthia, who, finding his real enemy dead, made peace, and returned into Parthia. See **PARTHIA**. Something is also said of the severity of this emperor's discipline; for to such a pitch of licentiousness was the Roman army now arrived that the most severe punishments were unable to restrain the soldiers; and yet the most gentle inflictions were looked upon as severity. It was this rigorous discipline; with the artifices of Mæsa, grandmother to Heliogabalus the natural son of Caracalla, that caused the emperor's ruin. Heliogabalus was priest of a temple dedicated to the sun, in Emesa, a city of Phœnicia; and, though but fourteen years old, was greatly loved by the army for the beauty of his person, and the memory of his father, whom they still considered as their benefactor. This was soon perceived by the grandmother; who, being very rich in gold and jewels, gave liberal presents among them, while they frequently repaired to the temple, both from the garrison in the city and the camp of Macrinus. This intercourse growing every day more frequent, the soldiers, disgusted with the severities of Macrinus, began to think of placing Heliogabalus in his stead. Accordingly, sending for him to their camp, he was immediately proclaimed; and such were the hopes of his virtues that all men began to affect his interests. Macrinus, who was pursuing his pleasures at Antioch, gave but little attention to the first report: only send-

ing his lieutenant Julian, with some legions, to quell the insurrection. However these, like the rest, soon declared for Heliogabalus, and slew their general. Macrinus found he had treated the rebellion too slightly; he therefore resolved, with his son, to march directly against the seditionary legions, and force them to their duty. Both parties met on the confines of Syria: the battle was for some time furious and obstinate; but at last Macrinus was overthrown, and obliged to fly. His principal aim was to get to Rome, where he knew his presence was desired; wherefore he travelled through the provinces of Asia Minor with the utmost expedition and privacy, but unfortunately fell sick at Chalcedon. There those who were sent in pursuit overtook and put him to death, together with his son Diadumenus, after a short reign of one year and two months.

**HELIOGABALUS.**—The senate and citizens of Rome being obliged to submit to the appointment of the army, as usual, Heliogabalus ascended the throne at the age of fourteen. One at so early an age, invested with unlimited power and surrounded with flatterers, could act only as they directed. This young emperor having it in his power to indulge all his appetites, he studied only their gratification. As he is described by historians he appears a monster of sensuality. His short life is a tissue of effeminacy, lust, and extravagance. He married, in four years, six wives, and divorced them all. He built a temple to the sun; and, willing that his god should have a wife as well as himself, he married him to Pallas, and shortly after to the moon. His palace was a place of rendezvous for all the prostitutes of Rome, whom he frequently met naked, calling them his fellow-soldiers, and companions in the field. He was so fond of the sex that he carried his mother with him to the senate-house, and demanded that she should always be present when matters of importance were debated. He even went so far as to build a senate-house for women, with suitable orders, habits, and distinctions, of which his mother was made president. They met several times; all their debates turning upon the fashions of the day and the different formalities to be used in giving and receiving visits. To these follies he added great cruelty and boundless prodigality: he said that such dishes as were cheaply obtained were scarcely worth eating. His suppers, therefore, generally cost 6000 crowns, and often 60,000. He was always dressed in cloth of gold and purple, enriched with precious stones, and yet never wore the same habit twice. His palace, his chambers, and his beds, were all furnished of the richest stuffs, covered with gold and jewels. Whenever he took horse, all the way between his apartment and the place of mounting was covered with gold and silver dust strewn at his approach. These excesses were soon perceived by his grandmother Mæsa, whose intrigues had first raised him to the throne; so that she thought to lessen his power by dividing it. For this purpose, under a pretence of freeing him from the cares of public business, she persuaded him to adopt his cousin-german, Alexander Severus, as his successor; and likewise to make him his partner in the consul-

ship. Heliogabalus, having thus raised his cousin, had scarcely given him his power, when he wished again to take it away; but the virtues of this young prince had so greatly endeared him to the people and the army, that the attempt had like to have been fatal to the tyrant. The prætorian soldiers, mutinying, attempted to kill him as he was walking in his gardens; but he escaped by hiding himself from their fury. However, upon returning to their camp, they continued the sedition; requiring that the emperor should remove such persons from about him as oppressed the subjects, and contributed to contaminate him. They required also the being permitted to guard the young prince themselves, and that none of the emperor's favorites or familiars should be permitted to converse with him. Heliogabalus was reluctantly obliged to comply; and, conscious of the danger he was in, made preparations for death, when it should arrive, in a manner truly whimsical and peculiar. He built a lofty tower, with steps of gold and pearl, whence to throw himself headlong in case of necessity. He also prepared cords of purple silk and gold to strangle himself with; he provided golden swords and daggers to stab himself with; and poison to be kept in boxes of emerald, in order to obtain what death he chose best. Thus fearing all things, but particularly suspicious of the designs of the senate, he banished them all out of the city: he next attempted to poison Alexander, and spread a report of his death; but, perceiving the soldiers begin to mutiny, he immediately took him in his chariot to the camp, where he experienced a fresh mortification, by finding all the acclamations of the army directed only to his successor. This not a little raised his indignation, and excited his desire of revenge. He returned towards the city, threatening the most severe punishments against those who had displeased him, and meditating fresh cruelties. However the soldiers were unwilling to give him time to put his designs in execution: they followed him directly to his palace, pursued him from apartment to apartment, and at last found him concealed in a privy; a situation very different from that in which he expected to die. Having dragged him thence through the streets, with the most bitter invectives, and having despatched him, they attempted once more to squeeze his pampered body into a privy; but, not effecting this, they threw it into the Tiber, with heavy weights, that none might afterwards find or give it burial. This was the miserable and ignominious death of Heliogabalus, in the eighteenth year of his age, after a detestable reign of four years. His mother also was slain at the same time by the soldiers; as were also many of the opprobrious associates of his criminal pleasures.

**ALEXANDER SEVERUS.**—Alexander being without opposition declared emperor, the senate, with their usual adoration, were for conferring new titles upon him; but he modestly declined them all, alleging that titles were only honorable when given to virtue. This outset was a happy omen of his future virtues; and few princes in history have been more commended by their contemporaries, or indeed more deserved com-

mendation. To the most rigid justice he added the greatest humanity. He loved the good, and was a severe reprover of the lewd and infamous. His accomplishments were equal to his virtues. He was an excellent mathematician, geometrician, and musician; he was skilled in painting and sculpture; and in poetry few of his time could equal him. In short, such were his talents, and such the solidity of his judgment, that, though but sixteen years of age, he was considered as a wise man. The first part of his reign was spent in a reformation of the abuses of his predecessor. He restored the senators to their rank: nothing being undertaken without the most sage advisers, and most mature deliberation. Among the number of his advisers was his mother Mammaea, a woman eminent for her virtues and accomplishments, and who made use of her power to secure her son the affections of his subjects, and to procure them the most just administration. He was a rigid punisher of such magistrates as took bribes, saying that it was not enough to deprive such of their places; for, their trusts being great, their lives in most cases ought to pay for a breach of them. On the contrary, he thought he could never sufficiently reward such as had been remarkable for their justice and integrity, keeping a register of their names, and sometimes asking such of them as appeared modest and unwilling to approach him why they were so backward in demanding their reward, and why they suffered him to be in their debt? His clemency extended even to the Christians, who had been punished in the former reigns with unrelenting barbarity. Upon a contest between them and a company of cooks and vintners, about a piece of public ground, which the one claimed as a place for public worship, and the other for exercising their respective trades, he decided the point by his rescript, in these words: 'It is better that God be worshipped there in any manner than that the place should be put to uses of drunkenness and debauchery.' His abilities in war were equal to his assiduity in peace. The empire, which from the remissness and debauchery of the preceding reigns now began to be attacked on every side, wanted a person of vigor and conduct to defend it. Alexander faced the enemy wherever the invasion was most formidable, and for a short time deferred its ruin. His first expedition, in the tenth year of his reign, was against the Parthians and Persians, whom he opposed with a powerful army. The Persians were routed in a decisive engagement with great slaughter; the cities of Ctesiphon and Babylon were once more taken, and the Roman empire was restored to its former limits. Upon his return to Antioch his mother Mammaea sent for the famous Origen, to be instructed by him in the principles of Christianity; and, after discoursing with him for some time upon the subject, dismissed him, with a proper safeguard, to his native city of Alexandria. About the same time that Alexander was victorious in the east, Furius Celsus, his general, obtained a signal victory over the Mauritians in Africa. Varius Macrinus was successful in Germany, and Junius Palmatus returned conqueror from Armenia.

However these victories only hastened the decline of the empire, which was wasted by the exertion of its own strength. About the thirteenth year of his reign, the Upper Germans, and other northern nations, began to pour down immense swarms of people upon the more southern parts of the empire. They passed the Rhine and the Danube with such fury that all Italy was thrown into consternation; when the emperor made what levies he could, and went in person to stem the torrent; which he speedily effected. It was in the course of his successes against the enemy that he was cut off by a mutiny among his soldiers. The legions encamped about Moguntia, having been abominably corrupted during the reign of Heliogabalus, and trained up in all kinds of rapine and disobedience, required the most strict command. Alexander could neither endure their tumultuary obedience, nor they his regular discipline. They exclaimed that they were governed by an avaricious woman, and a mean-spirited boy; and resolved upon electing an emperor capable of ruling alone. In this general revolt, Maximinus, an old commander, held frequent conferences with the soldiers, and inflamed the sedition. At length they sent an executioner into Alexander's tent; who immediately struck off his head, and shortly after that of his mother. He died in the twenty-ninth year of his age, after a prosperous reign of thirteen years and nine days.

ROME UNTIL THE MURDER OF GORDIAN I. AND II.—The tumults occasioned by the death of Alexander being appeased, Maximinus, who had been the chief promoter of the sedition, was chosen emperor. This extraordinary man was born of very obscure parentage, being the son of a herdsman of Thrace. At first he followed his father's profession, and only exercised his personal courage against robbers. Soon after he enlisted in the Roman army, where he became remarkable for his great strength, discipline, and courage. He was no less than eight feet and a half high; and of strength corresponding to his size. His wife's bracelet served him for a thumb ring; and his strength was so great that he was able to draw a carriage which two oxen could not move. His diet was as extraordinary as the rest of his endowments; he generally ate forty pounds of flesh it is said every day, and drank six gallons of wine. With a frame so athletic, he was possessed of a mind undaunted in danger, neither fearing nor regarding man. The first time he was made known to the emperor Severus was upon his celebrating games on the birth-day of his son Geta. Maximinus was then a rude countryman, and requested the emperor to be permitted to contend for the prizes which were distributed. Severus, unwilling to infringe the military discipline, would not permit him to combat, except with slaves, against whom his strength appeared astonishing. He overcame sixteen in running, one after the other; he then kept up with the emperor on horseback; and, having fatigued him in the course, he was opposed to seven of the most active soldiers, and overcame them with the greatest ease. From that time he was noticed, and taken into the emperor's body-guards, in which his assiduity

and prompt obedience were remarked. In the reign of Caracalla he was made a centurion, and distinguished himself in this station by his strict attention to morals and discipline. When made a tribune, he still retained the hardy simplicity of his life; eat as the meanest sentinel; spent whole days in exercising his troops; and now and then wrestled with eight or ten of the strongest men in the army. When Macrinus was made emperor, he refused to serve under a prince that had betrayed his sovereign; and retired to Thrace, his native country, where he followed commerce and purchased some lands. Upon the accession of Heliogabalus, this bold veteran once more returned to the army; but was disgusted at the effeminacy of the emperor; who, hearing amazing instances of his strength, asked him if he were equally capable in combats of another nature? This question was so little suited to the temper of Maximinus that he left the court. Upon the death of Heliogabalus he again returned to Rome, and was received with great kindness by Alexander, who recommended him to the senate, and made him commander of the fourth legion, which consisted of new raised soldiers. Maximinus performed his duty with great exactness and success. Nor was his valor less apparent against the Germans; so that he was unanimously reckoned the boldest, bravest, and most virtuous soldier in the empire. He soon, however, forfeited these titles, when raised to the throne; and became the most cruel tyrant upon earth. The senate and people of Rome were the first that incurred his resentment, they absolutely refusing to confirm the election made by the army, and he became the first emperor who reigned without their concurrence. The Christians felt the weight of his resentment; and were persecuted in several parts of the empire. His cruelty particularly extended to the rich, whose lives and estates became a frequent sacrifice to his avarice and suspicion. Being ashamed of the meanness of his extraction, he commanded all such as were acquainted with him and his parentage to be slain. In the midst of these cruelties his military operations were carried on with a spirit becoming a better monarch. He overthrew the Germans in several battles, and wasted their country with fire and sword. To attach the soldiers firmly to him, he increased their pay; and, in every duty of the camp, he himself took as much pains as the meanest sentinel. In every engagement, where the conflict was hottest, Maximinus was always seen fighting in person. In the mean time his cruelties had so alienated the minds of his subjects that several conspiracies were formed against him. Magnus, a consular person, and some others had agreed in a plot to break down a wooden bridge, as soon as the emperor had passed it, and thus to abandon him to the enemy. But this, being discovered, gave Maximinus an opportunity of indulging his natural severity, who upon this pretext alone caused above 4000 to be slain. Shortly after some of Alexander's old soldiers, withdrawing themselves from the camp, proclaimed one Quartianus emperor; but shortly after, in the spirit of the times, the person who had been the promoter of his advancement, murdered him in

his bed, and carried his head to Maximinus; who received the present kindly, but put the bearer to a cruel death, for his complicated treason and treachery. These partial insurrections were followed by a spirit of general discontent throughout the empire. The provinces of Africa were the first that showed their detestation of the tyrant. They first slew his procurator; and afterwards resolved to throw off all expectation of pardon, and create a new emperor. Gordian was then proconsul, a person of great fame for his virtues, and highly revered for a blameless life of near eighty. Him, therefore, they determined to elect; and accordingly the soldiers and natives, assembling together, tumultuously entered his house. Gordian, who at first supposed they were come to kill him, being made sensible of their intentions, refused their offer, alleging his great age. But they constrained him to accept of the dignity; and he, with his son Gordian, who was forty-six years of age, were declared emperors. The old man immediately wrote to the senate, declaring that he had unwillingly accepted of the empire, and would only keep his authority till he had freed their common country from the tyranny of its present oppressor. The senate very joyfully confirmed his election, adjudging Maximinus an enemy and traitor to the state. The citizens also showed an equal zeal in the cause: they flew upon such as were the reputed friends of Maximinus, and tore them to pieces. So great an alteration being made in the city against Maximinus, the senate made all necessary preparations for their security, ordering Maximinus's governors to be displaced. This order was differently received in different parts; in some provinces the governors were slain; in others the messengers of the senate; so that all parts of the empire felt the civil war. In the mean time, when Maximinus was informed of these charges against him, his rage appeared ungovernable. He roared like a savage beast, and violently struck his head against the wall. At length, his fury having somewhat subsided, he called his whole army together; and, in a set speech, exhorted them to revenge his cause, giving them the strongest assurances that they should possess the estates of all such as had offended. The soldiers unanimously promised to be faithful; they received his harangue with their usual acclamations; and, thus encouraged, he led them towards Rome, breathing slaughter and revenge. However, he found many obstacles to his impetuosity; and, though he desired nothing so much as despatch, his marches were incommodious and slow. The tumultuous and disobedient armies of the empire were at present very different from the legions that were led on by Sylla or Cæsar; they were loaded with baggage, and followed by slaves and women, rather resembling an eastern caravan, than a military battalion. To these inconveniences was added the hatred of the cities through which he passed, the inhabitants abandoning their houses upon his approach, and securing their provisions in proper hiding places. However, his affairs began to wear a favorable appearance in Africa; for Capelianus, governor of Numidia, raised a body of troops in his favor, and marched against

Gordian, towards Carthage; where he fought the younger Gordian, slew him, and destroyed his army. The father, hearing of the death of his son, together with the loss of the battle, strangled himself in his own girdle.

**ROME UNTIL THE MURDER OF MAXIMINUS.**—Capelianus pursuing his victory entered Carthage; where he gave a loose to pillage and slaughter, under a pretence of revenging the cause of Maximinus. The news of these successes was soon brought to the emperor, who now increased his diligence, and flattered himself with a speedy opportunity of revenge. He led on his large army by hasty journeys into Italy, threatening destruction to all his opposers. Nothing could exceed the consternation of the senate upon the news of this defeat. They now saw themselves not only deprived of the assistance of Gordian and his son, but also opposed by two formidable tyrants, each commanding a victorious army, directly marching towards Rome. In this afflicting exigence, they, with great solemnity, met at the temple of Jupiter, and after the most mature deliberations chose Pupienus and Balbinus emperors conjointly. These were men who had acquired the esteem of the public both in war and peace, having commanded armies, and governed provinces with great reputation; and being now appointed to oppose Maximinus, they made what levies they could. With these, Pupienus marched to stop the progress of the invaders, leaving the city to a fresh and unlooked for calamity. This was occasioned by two of Maximinus's soldiers, who, entering the senate house, were slain by two senators. This quickly gave offence to the body of the prætorian soldiers, who instantly resolved to take revenge, but were opposed by the citizens; so that nothing was seen throughout Rome, but tumult, slaughter, and cruelty. In this universal confusion, the calamity was increased by the soldiers setting the city on fire. Nevertheless, Maximinus himself was not more fortunate. Being informed of the new election of emperors, his fury was renewed, and he passed the Alps, expecting, upon entering Italy, to refresh his fatigued and famished army in that fertile country. Approaching Aquileia he was astonished to find it prepared for the most obstinate resistance, and resolved to hold out a regular siege. At last a mutiny in his army rescued the declining empire from destruction. The soldiers being long harassed by famine and fatigue, and hearing of revolts on every side, resolved to terminate their calamities by the tyrant's death, and slew both him and his son, whom he had made his partner in the empire, after a usurpation of about three years, in the sixty-fifth year of his age.

**PUPIENUS AND BALBINUS.**—The tyrant being dead, and his body thrown to birds of prey, Pupienus and Balbinus continued emperors without opposition. But the prætorian soldiers, notorious for mutiny and treason, resolved on further change. The dissensions between the new made emperors themselves also contributed to their downfall: for though both were remarkable for wisdom and age, yet they could not restrain their mutual jealousy. Pupienus claimed the supe-

riority for his great experience; while Balbinus was equally aspiring upon account of his family and fortune. In this ill-judged contest, the prætorian soldiers, who were enemies to both, set upon them in their palace, at a time when their guards were amusing themselves with the Capitoline games. Pupienus, perceiving their tumultuous approach, sent with the utmost speed for assistance from his colleague: but he, out of suspicion that something was designed against himself, refused to send such of the German guards as were next his person. Thus the seditious soldiers found an easy access to both the emperors; and, dragging them from the palace to the camp, slew them both.

**GORDIAN III.**—In the midst of this sedition, as the mutineers were proceeding along the streets of the capital, they met Gordian, the grandson of him who was slain in Africa, and declared him emperor. This prince was but sixteen years old, but his virtues seemed to compensate for his want of experience. His learning was equal to his virtues; and he had 62,000 volumes, we are told, in his library. His respect for Misithæus, his governor and instructor, was such that he married his daughter, and profited by his counsels throughout his reign. The first four years were attended with the utmost prosperity; but in the fifth he was alarmed with accounts from the east, that Sapor, king of Persia, had furiously invaded the confines of the Roman empire, and, having taken Antioch, had pillaged Syria, and all the adjacent provinces. The Goths also invaded the empire on their side, pouring down like a flood from the north, and attempting to fix their residence in the kingdom of Thrace. To oppose both, Gordian prepared an army; and having gained some victories over the Goths, whom he obliged to retire, he turned his arms against the Persians, whom he defeated upon several occasions. But his only successful general died suddenly, and things then proceeding from bad to worse, Philip, an Arabian chief, was at first made his equal in the empire, and shortly after invested with the sole power. Gordian was, by his order, slain, in the twenty-second year of his age, after a successful reign of nearly six years.

**PHILIP.**—Philip, having thus murdered his benefactor, was acknowledged emperor by the army. The senate confirmed his election, and gave him the title of Augustus. He was about forty years old when he came to the throne; being the son of an obscure Arabian, who had been a captain of banditti. He associated with him in the empire his son, a boy of six years of age; and, to secure his power at home, made peace with the Persians, and marched his army towards Rome. On his way, having conceived a desire to visit his native country of Arabia, he built there a city called Philippopolis: and thence returning to Rome was received as emperor with all the usual marks of submission. To put the people in good humor, he caused the secular games to be celebrated, with a magnificence superior to any of his predecessors. But, the Goths having invaded the empire, Marinus, Philip's lieutenant, who was sent against them, revolted, and caused himself to be declared emperor. This

revolt, however, was of short duration; and Decius was appointed by Philip to command in his room. However, the army was scarcely arrived at Verona, when it revolted in favor of Decius, and setting violently upon Philip, a sentinel, with one blow, cleaved his head asunder, separating the under jaw from the upper. Such was the deserved death of Philip, in the forty-fifth year of his age, after a reign of about five years: Decius being universally acknowledged as his successor, A. D. 348.

**DECIVS AND HIS SON.**—The activity and wisdom of Decius in some measure arrested the hastening decline of the empire. The senate seemed to think so highly of his merits that they voted him not inferior to Trajan; and indeed he seemed in every instance to consult their dignity, and the welfare of the people. He permitted them to choose a censor, as in the flourishing times of Rome; and Valerian, his general, a man of such strict morals that his life was said to be a continual censorship, was chosen to that dignity. But no virtue could now prevent the approaching downfall of the state: the obstinate disputes between the Pagans and the Christians within the empire, and the unceasing irruptions of barbarous nations from without, enfeebled it beyond remedy. To stop these, a persecution of the Christians, now a most numerous body, was impolitically and cruelly begun; thousands were put to death, and all the arts of cruelty tried in vain to lessen their growing number. This was succeeded by dreadful devastations from the Goths, in Thrace and Mæsia. These irruptions Decius went to oppose in person; and, coming to an engagement, slew 30,000 of these barbarians in one battle. But, in pursuing his victory, he was, by the treachery of Gallus his own general, led into a defile, where the Goths had secret information to attack him. In this disadvantageous situation, Decius first saw his son killed with an arrow, and soon after his whole army put to the rout. Wherefore, resolving not to survive his loss, he put spurs to his horse, and plunging into a quagmire was swallowed up. He died in the fiftieth year of his age, after a short reign of two years and six months; leaving the character of an excellent prince.

**GALLUS AND ÆMILIANUS.**—Gallus, who had thus betrayed the army, had the address to get himself declared emperor by that part of it which had survived the defeat; he was forty-five years old when he began to reign, and was descended from an honorable family. He now agreed to pay a considerable annual tribute to the Goths; and, having thus purchased a short remission from war, returned to Rome, to give a loose to his pleasures. Nothing could be more deplorable than the state of the provinces at this time. The Goths and other barbarous nations, not satisfied with their late bribes, broke in upon the eastern parts of Europe. On the other side the Persians and Scythians committed unheard of ravages in Mesopotamia and Syria. The emperor, regardless of every national calamity, was lost in debauch and sensuality; and the Pagans were allowed a power of persecuting the Christians through all parts of the state: these calamities



were succeeded by a pestilence that seemed to have spread over the earth, and continued raging for several years; and all these by a civil war, which followed soon after, between Gallus and his general Æmilianus, who, having gained a victory over the Goths, was proclaimed emperor by his army. Gallus, hearing this, prepared to oppose his dangerous rival. Both armies met in Mœsia, and a battle ensued, in which Æmilianus was victorious, and Gallus, with his son, slain. He died in the forty-seventh year of his age, after an unhappy reign of two years and four months. Æmilianus, after his victory over Gallus, expected to be acknowledged emperor; but was miserably disappointed. The senate refused to acknowledge him; and an army stationed near the Alps chose Valerian, their own commander, to succeed to the throne. Æmilianus's soldiers began to consider their general as an obstacle to the public tranquillity, and slew him to avoid a civil war.

**VALERIAN.**—Valerian being universally acknowledged as emperor, although arrived at the age of seventy, set about reforming the state with a spirit that seemed to mark a good mind and unabated vigor. But reformation was then grown almost impracticable. The disputes between the Pagans and Christians divided the empire as before; and a dreadful persecution of the latter ensued. The northern nations overran the Roman dominions in a more formidable manner than ever; and the empire began to be usurped by a multitude of petty leaders, each of whom, neglecting the general state, set up for himself. To add to these calamities, the Persians, under Sapor, invaded Syria; and, coming into Mesopotamia, took the unfortunate Valerian prisoner, as he was preparing to oppose them. Nothing can exceed the indignities and cruelties practised upon this unhappy monarch. Sapor used him as a footstool for mounting his horse, and, adding the bitterness of ridicule to his insults, observed that an attitude like that to which Valerian was reduced, was the best statue that could be erected in honor of his victory. This life of insult and suffering continued for seven years, and was at length terminated by the cruel Persian's commanding his prisoner's eyes to be plucked out, and causing him to be flead alive.

**THE REIGN OF THE THIRTY TYRANTS.**—The news of the defeat of the Roman army by the Persian, and the captivity of Valerian, no sooner reached the barbarous nations at war with Rome than they poured on all sides into the Roman territories in incredible multitudes. The Goths and Scythians ravaged Pontus and Asia, committing every where dreadful devastations; the Alemanni and Franks, having over-run Rhetia, advanced as far as Ravenna, putting all to fire and sword; the Quadi and Sarmatians seized on great part of Dacia and Pannonia; while other barbarous nations, invading Spain, made themselves masters of Tarraco, and other places in that province. In the mean time Gallienus, the son of Valerian, having promised to revenge his father's captivity, and repress the barbarians, was chosen emperor. He was then in Gaul; but hastened into Italy, whence he drove out the

barbarians. In Dacia and Pannonia, also, they were driven back by Regilianus, who gained several victories in one day. But in the mean time, one Ingenus, a man of great reputation in war, and universally beloved both by the people and soldiery, caused himself to be proclaimed emperor in Pannonia, where he was generally acknowledged as well as in Mœsia. Gallienus no sooner heard of his revolt, than he marched from the neighbourhood of Ravenna, where he then was, into Illyricum, engaged Ingenus, and put him to flight. Some say that Ingenus was killed after the battle by his own soldiers; others affirm that he put an end to his own life to avoid falling into the hands of Gallienus, who used his victory with a cruelty hardly paralleled. His letter to Verianus Celer, one of his officers, will show his disposition:—'I shall not be satisfied,' says he, 'with your putting to death only such as have borne arms against me, and might have fallen in the field; you must in every city destroy all the males, old and young; spare none who have wished ill to me; none who have spoken ill of me the son of Valerian, the father and brother of princes. Ingenus emperor! Tear, kill, cut in pieces without mercy; you understand me; do then as you know I would do, who have written to you with my own hand.' In consequence of these cruel orders, a most dreadful havoc was made among that unhappy people; and, in several cities, not one male child was left alive. The troops who had formerly served under Ingenus, and the inhabitants of Mœsia who had escaped the general slaughter, provoked by these cruelties, proclaimed Regilianus emperor. He was a Dacian by birth, descended from king Decebalus whom Trajan had conquered; and had, by several gallant actions, gained reputation in the Roman armies. After he was proclaimed emperor, he gained great advantages over the Sarmatians; but was soon after murdered by his own soldiers. These revolts were quickly followed by many others. Indeed it is not surprising, at a time when the reins of government were held with so loose a hand, that a crowd of usurpers should start up in every province of the empire. The great number of usurpers who pretended to the empire about this time have been distinguished by the name of the thirty tyrants. There were, however, only twenty: viz. Cyriades, Macrinus, Balista, Odenatus, and Zenobia, in the east; in Gaul and the western provinces Posthumius, Lollianus, Victorinus and his mother Victoria, Marius, and Tetricus; in Illyricum, and on the confines of the Danube, Ingenus, Regilianus, and Aureolus; in Pontus Saturninus; in Isauria Trebellianus; in Thessaly Piso; in Achaia Valens; in Egypt Æmilianus; and in Africa Celsus. Several of these pretenders to the empire, however, though branded with the opprobrious appellation of tyrants, were eminent for virtue, and almost all of them possessed a considerable share of vigor and ability. The principal reason assigned for their revolt was the infamous character of Gallienus, whom neither officers nor soldiers could bear to serve. Many of them were forced by the soldiers to assume the imperial dignity much against their will. 'You

have lost,' said Saturninus to his soldiers, when they invested him with the purple, 'a useful commander, and have made a wretched emperor.' The apprehensions of Saturninus were justified by the event. Of the twenty usurpers above-mentioned, not one died a natural death; and in Italy and Rome Gallienus alone continued to be acknowledged emperor. That prince indeed honored Odenatus prince of Palmyra with the title of Augustus, who continued to possess an independent sovereignty in the east all his lifetime, and on his death transmitted it to his wife Zenobia.

The consequences of these numerous usurpations were the most fatal that can be conceived. The elections of these precarious emperors, their life and death, were equally destructive to their subjects and adherents. The price of their elevation was instantly paid to the troops by an immense donative drawn from the exhausted people. When they fell, they involved armies and provinces in their fall; and, whilst the forces of the state were dispersed in private quarrels, the defenceless provinces lay exposed to every invader. The bravest usurpers were compelled, by the perplexity of their situation, to conclude dishonorable treaties with the barbarians, and even to submit to shameful tributes, and introduced such numbers of barbarians into the Roman service as seemed sufficient at once to overthrow the empire. But when the empire seemed thus ready to sink at once, it suddenly revived on the death of Gallienus, who was murdered by Martian, one of his own generals, while he besieged Aureolus, in Milan. His death gave general satisfaction to all, except his soldiers, who hoped to reap the reward of their treachery by the plunder of Milan. But, being in some measure kept within bounds by the largesses of Martian, Flavius Claudius was nominated to succeed, and joyfully accepted by all orders of the state, and his title confirmed by the senate and the people.

CLAUDIUS II.—Claudius, some say, was born in Dalmatia, and descended from an ancient family there; others that he was a Trojan; and others that he was son to the emperor Gordian. But, whatever might have been his descent, his merits were by no means doubtful. He was a man of great valor and conduct, having performed the most eminent services against the Goths, who had long continued to make irruptions into the empire. Now about fifty-five years old, he was equally remarkable for the strength of his body and the vigor of his mind. Thus endowed he once more seemed to restore the glory of Rome. His first success, upon being made emperor, was against Aureolus, whom he defeated near Milan. His next expedition was to oppose the Goths, against whom he led a very numerous army. These barbarians had made their principal and most successful irruptions into Thrace and Macedonia, swarmed over all Greece, and had pillaged the famous city of Athens, which had long been the school of all the polite arts to the Romans. The Goths, however, destroyed all monuments of taste and learning with the most savage avarice. It was upon one of these occasions that, having heaped together a large

pile of books to burn them, one of the commanders dissuaded them from the design, alleging that the time which the Grecians wasted on books would only render them more unqualified for war. But the empire trembled not only on that side, but on every quarter. Above 300,000 of these barbarians (the Heruli, the Trutangi, the Viturgi, and many other uncivilised nations) came down the Danube with 2000 ships, spreading terror and devastation on every side. In this state of universal dismay Claudius alone continued unshaken. He marched his disproportioned army against the savage invaders; and though but ill prepared for such an engagement, the forces of the empire were then employed in different parts of the world, he came off victorious, and made an incredible slaughter of the enemy. The whole of their great army was either cut to pieces or taken prisoners; houses were filled with their arms; and scarcely a province of the empire that was not furnished with slaves from those that survived the defeat. These successes were followed by many others in different parts of the empire; so that the Goths, for a considerable time after, made but a feeble opposition. He some time after marched against the revolted Germans, and overthrew them with considerable slaughter. His last expedition was to oppose Tetricus and Zenobia, his two puissant rivals in the empire. But on his march, as he approached near Sirmium, in Pannonia, he was seized with a pestilential fever, of which he died in a few days, to the great regret of his subjects, and the irreparable loss of the empire. His reign, which was not quite two years' continuance, was active and successful; and such is the character given of him by historians that he is said to have united in himself the moderation of Augustus, the valor of Trajan, and the piety of Antoninus.

AURELIAN.—Immediately after the death of Claudius the army made unanimous choice of Aurelian, master of the horse, and esteemed the most valiant commander of his time. However his promotion was not without opposition on the part of the senate, as Quintillus, the brother of the deceased emperor, put in his claim, and was for a while acknowledged. But his authority was of very short duration; finding himself abandoned by those who at first instigated him to declare for the throne, he chose to prevent the severity of his rival by a voluntary death, and, causing his veins to be opened, expired, after having reigned but seventeen days. Aurelian, being now universally acknowledged, assumed the command with a greater show of power than his predecessors had for some time enjoyed. This active monarch was born of obscure parentage in Dacia, and was about fifty-five years old at his coming to the throne. He had spent the early part of his life in the army, and risen through all the gradations of military duty. He was of unshaken courage and amazing strength. In short, his valor and expedition were such, that he was compared to Julius Cæsar, and only wanted mildness and clemency to be every way his equal. The whole of his reign was spent in repressing the irruptions of the northern nations, in humbling every pretender to the empire, and punishing the monstrous in-

regularities of his subjects. He defeated the Marcomanni, that had invaded Italy, in three several engagements, and totally destroyed their army. He was not less successful against Zenobia, the queen of the east, a woman of the most heroic qualifications, who had long disclaimed the Roman power, and established an empire of her own. Aurelian having thus brought peace to the empire, endeavoured, by the rigors of justice, to bring back virtue also. Against the Christians, however, he drew up several letters and edicts, which showed that he intended a very severe persecution; but, if we may believe the historians of the times, he was diverted just as he was going to sign them by a thunder-bolt, which fell so near his person that all the people judged him to be destroyed. It is certain that his severities, at last, were the cause of his destruction. Menesthus, his principal secretary, apprehending his displeasure, forged a roll of the names of several persons, whom he pretended the emperor had marked out for death. The scroll thus contrived was shown with an air of the utmost secrecy to some of the persons concerned; and as the emperor passed with a small guard from Uraclea, in Thrace, towards Byzantium, the conspirators set upon him and slew him with little resistance, in the sixtieth or sixty-third year of his age.

TACITUS.—The army now referred the choice of emperor to the senate; and, on the other side, the senate declined it; so that a space of nearly eight months elapsed in these negociations. At length, the former made choice of Tacitus, a man of great merit, and no way ambitious of the honor. One of the first acts of his government was the punishment of those who had conspired against the late emperor. During this short reign, the senate seemed to have a large share of authority, and the historians of the times are liberal of their praises of such emperors as were thus willing to divide their power. Tacitus was fond of learning, and the memory of such men as had deserved well of their country. He particularly esteemed the works of Tacitus the historian, commanding that they should be placed in every public library throughout the empire. A reign begun

with such moderation and justice only wanted continuance to have made the empire happy; but, after enjoying the empire about six months, he died of a fever, in his march to oppose the Persians and Scythians, who had invaded the eastern parts of the empire.

PROBUS.—Upon the death of Tacitus the army was divided; one part of it chose Florianus, brother to the deceased; but the majority were for some time undetermined. At last Probus was called to the throne, being born of noble parentage at Sirmium in Pannonia, and bred up a soldier from his youth. He first repressed the Germans in Gaul, of whom he slew 400,000. He then marched into Dalmatia, to subdue the Sarmatians. Thence he led his forces into Thrace, and forced the Goths to sue for peace. He afterwards turned his arms towards Asia, subdued the province of Isauria, and, marching onward, conquered a people called the Blemyes. Narses also, king of Persia, submitted to him. His diligence was not less conspicuous in suppressing intestine commotions. Proculus, a person remarkable only for his great attachment to women, set up against the emperor; but was compelled to fly, and at length delivered up by the Germans. At the same time Bonosus (a remarkable votary of Bacchus, being able to drink as much wine as ten could do) rebelled, and, being overcome, hanged himself in despair. Probus, when he saw him immediately after, said, 'there hangs not a man, but a cask.' The Goths and Vandals, however, finding the emperor engaged in quelling domestic disputes, renewed their accustomed inroads, but were conquered in several engagements. In his last expedition he led his soldiers against the Persians; and going through Sirmium, the place of his nativity, there employed several thousands in draining a fen that was incommodious to the inhabitants. The fatigues of this undertaking, and the great restraint that was laid upon the soldier's manners, produced a conspiracy, which ended in his ruin; for, taking the opportunity as he was marching into Greece, they set upon and slew him, after he had reigned six years and four months with general approbation.



END OF VOL. XVIII.







