

Christmas Ornament Display Structure

By
Ryan Palmer, Miles Roux, and Dolores Gallardo
Team 07

Project Proposal Document

*Submitted towards partial fulfillment of the requirements for
Mechanical Engineering Design – Fall 2012*



Department of Mechanical Engineering
Northern Arizona University
Flagstaff, AZ 86011

TABLE OF CONTENTS

PROBLEM STATEMENT	3
BACKGROUND	3
INTRODUCTION	3
NEEDS IDENTIFICATION	3
PROJECT GOAL	3
OBJECTIVES	4
CONSTRAINTS	4
CRITERIA TREE	5
QUALITY FUNCTION DEPLOYMENT & HOUSE OF QUALITY	5
CONCEPT GENERATION	7
CONCEPT SELECTION	8
MODIFICATIONS TO SIDEWAYS ARCH DESIGN	12
ENGINEERING ANALYSIS	13
FINAL DESIGN	20
MATERIALS AND GEOMETRIES CONSIDERED	20
COST ANALYSIS	21
CAD DRAWINGS AND GEOMETRY DIMENISONS	22
FUTURE TASKS	24
PROJECT PLAN	26
CONCLUSION	29
REFERENCES	30
APPENDIX: ADDITIONAL DISPLAY STAND FIGURES	31

PROJECT STATEMENT

BACKGROUND

My Star of Bethlehem LLC is a small business founded by Sandy Lochow in October of 2011 that operates out of Sedona, Arizona. Sandy and her husband, Dieter Otte, grew up just a few miles outside of Hernhut, Germany where the original Hernhut Christmas stars were conceived. After relocating to the United States over ten years ago, Sandy decided to bring the stars to America and open up her own store. My Star of Bethlehem LLC sells Christmas ornaments which are both manufactured and imported directly from Germany.

INTRODUCTION

In order to help market these Christmas ornaments, My Star of Bethlehem LLC would like to have a portable display stand designed and manufactured to highlight their products at venues such as store fronts and malls. The structure will display one ornament at a time elevating it at least six to eight feet above the ground. The design needs to be collapsible, light-weight, easy to setup and easy to take down.

NEEDS IDENTIFICATION

The client, My Star of Bethlehem LLC, indicated that they do not have an aesthetically pleasing way to easily display their Christmas ornaments when marketing their products locally. Presently, when the company is promoting their products they use a square four legged tent with three tables setup underneath in a U-shaped configuration. The Christmas stars are both displayed on these tables and hung from the top of the tent frame.

PROJECT GOAL

The goal is to design a better way to display the Christmas ornaments when My Star of Bethlehem LLC is marketing their products to potential customers. This design will provide an effective means to display their products at trade shows, private properties, shopping malls etc. Currently, this display stand is being designed for promotional applications, however; it may also have potential consumer applications depending on cost and other design criteria.

OBJECTIVES

- Inexpensive – It is important that the display stand be affordable and therefore inexpensive so that it is attractive from a sales standpoint and easy to promote.
- Easy to assemble/disassemble – By incorporating into the design an easy assembly, less time will be spent setting up and more time devoted to sales.
- Durability – If the stand material is not strong, it is likely to damage easily and break. The display stand must not damage the Christmas ornament and vice versa.
- No Damage to Star – The more damage incurred to the Christmas star from the display stand, the higher the repair costs are for the consumer. Repair costs should be kept low.
- Recyclable – It would be nice if most or the entire stand is recyclable to both reduce waste and provide the consumer with a portion of the initial investment back if they choose to sell it back to a scrap metal recycler.
- Reliability – A reliable product is easier to market. The less time the customer spends servicing the product, the more time the customer can spend using it. Additionally, more money is kept in the consumer’s pocket.

Table 1: Objectives with corresponding measurements and units

Objectives	Basis for Measurement	Units
Durability	Lifespan should be \geq the ornament	Years (yr)
Will not damage star	Cost to repair a damaged ornament	Dollars (\$)
Recyclable	Amount of recyclable materials	Percent (%)
Reliability	Will not require frequent maintenance	Years (yr)
Ease of assembly	Time to assemble	Time (min)
Inexpensive	Cost to consumer stays within \$500.00	Dollars (\$)

CONSTRAINTS

- Ornament(s) need(s) to be elevated a minimum of six to eight feet above ground.
- Display stand must be light enough for one adult to carry.
 - Each individual component weighs less than 50 pounds.
- Ornament needs to be hung or mounted.
- Stand assembly time must not exceed thirty minutes.
- Stand must support two different sized ornaments.
 - Medium size: diameter = 2.29 feet, weight = 2.94 pounds
 - Large size: diameter = 4.27 feet, weight = 7.19 pounds
- Structure needs to be free standing.

CRITERIA TREE

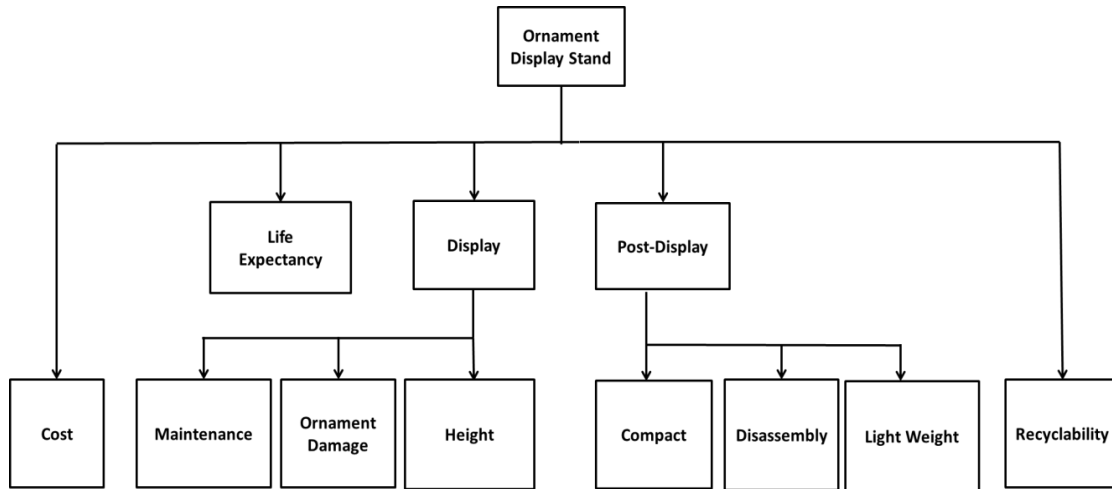

Figure 1: Design criteria used in concept selection

The criteria tree in Figure 1 models the requirements for the display stand during and before showcasing the ornament. Also, other criteria that are not part of display or post-display are included. The requirements for the display stand helped in the analysis and design process for this project.

QUALITY FUNCTION DEPLOYMENT & HOUSE OF QUALITY

	Engineering Requirements							
	Yield Strength	Modulus of elasticity	Material thickness	Height	Weight	Deflection	Center of gravity	Cost
Customer Requirements								
Freestanding	X		X		X		X	X
Collapsible			X	X	X	X		X
Lightweight	X		X	X	X			
Easy to assemble and disassemble				X	X			
Ornament elevated at least 6 to 8 feet off the ground	X	X	X	X	X	X	X	X
Portable			X	X	X			
Resistant to weather	X	X				X	X	X

Figure 2: Comparison of customer requirements to engineering requirements

CONCEPT GENERATION

The processes involved in design concept generation are brainstorming, discussing the designs that have been proposed, narrowing down those designs based on certain criteria and finally selecting the most viable design options to be considered for analysis and prototyping. During the brainstorming process, team members present as many ideas as possible while taking into consideration that the only criteria is that the design provide a solution to the problem. This process often results in several designs that are easy to eliminate based on their practicality of application and manufacturing.

This practicality of design is another general criterion which sometimes causes the most extravagant and innovative designs to be eliminated. This tends to happen because the most creative designs are sometimes the least viable due to manufacturing or application restrictions. Through this process, the designs become more feasible in nature and fewer in number which results in a more concise design ranking and decision making process.

The final step in the concept generation process is to select a subset of the most practical designs based on design criteria. This process is intended to be carried out in an objective nature while assigning estimated values to the designs being considered. This data will be compiled into tables that will assist in making an informed decision based on a quantitative representation of how well each design meets certain criteria.

CONCEPT SELECTION

The following designs resulted from the concept generation process and were selected based on practicality, constraint satisfaction and project objectives.

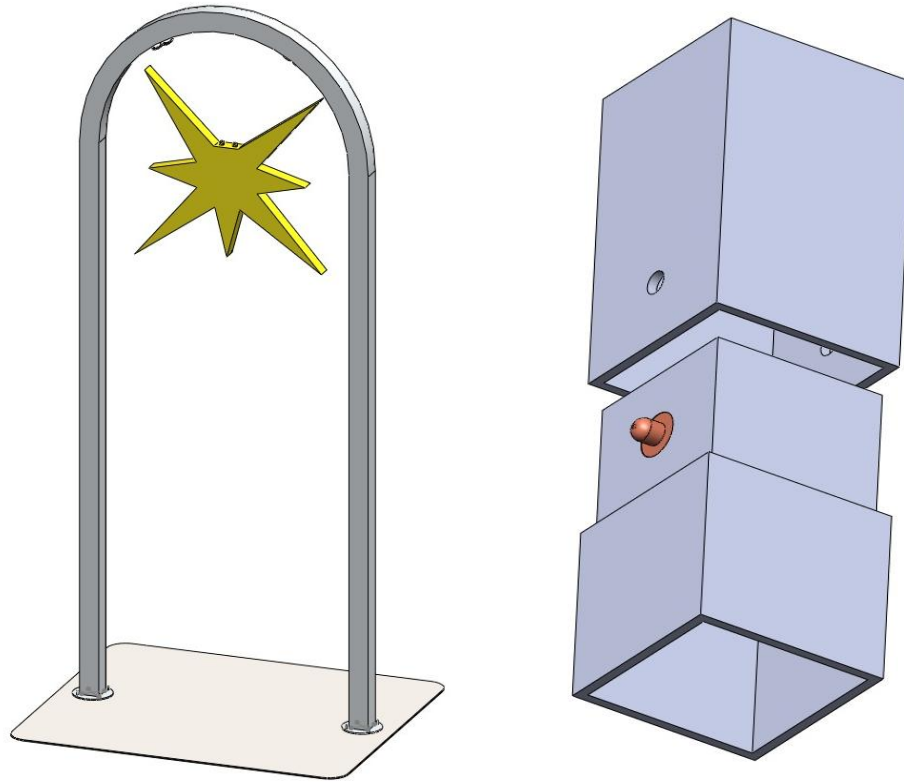

Figure 4: Design 1 – The Festive Arch

The Festive Arch is a design that resembles an altar from which the ornament will hang. This design incorporates four sections; the first section starting from the bottom is the base to which the support posts will mount. The second section, which includes both of the supporting posts, consists of two parts; these parts attach the base of the assembly to the remaining sections of the stand. The third section of the arch also contains two parts similar to those in the second section. The notable difference is that they serve the purpose of connecting the tubing mounted on the base to the arch using spring loaded locking pins which can be seen in Figure 4 on the right. The fourth section is the arch itself. The ornament will be suspended from two fastening cleats that are mounted on the underside of the arch using a rope that is provided in the ornament assembly kit. The electrical connection, which consists of a heavy duty electrical cord, emerges from the ornament where it is missing a spire. This cord will be inserted in a hole underneath the apex of the arch and fed through the hollow square tubing. Upon reaching the base of the stand, the cord will be retrieved through a hole in the support post. This cord will be plugged into an electrical outlet to illuminate the ornament.

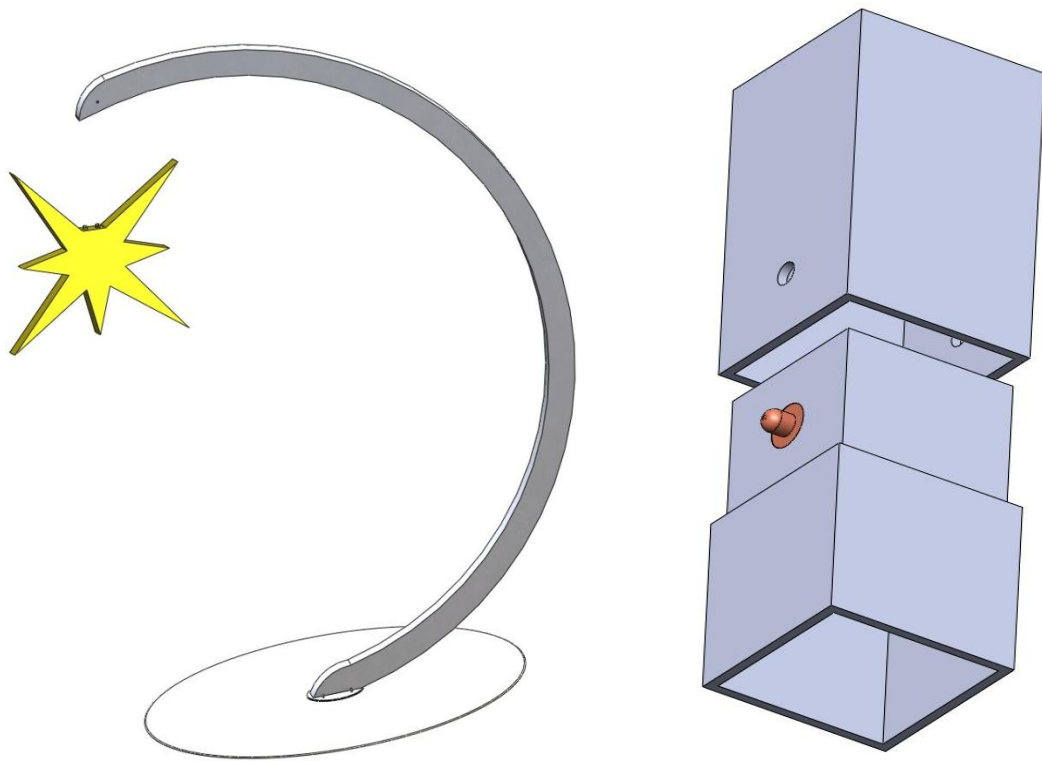

Figure 5: Design 2 – The Sideways Arch

The Sideways Arch, as shown in Figure 5, is similar to an egg shape and contains four sections. The first of these sections is the base to which the arch will be mounted. Studs embedded in the base will employ wing nuts to fasten the arch to the base. The second section contains the bottom of the arch that will facilitate the rest of the assembly. The third section is the middle of the arch that will be inserted between the first and final sections of the arch using spring loaded locking pins which can be seen on the right in Figure 5. Upon assembling the first three sections of the arch, the user will attach the ornament to the fourth section of the arch using the rope provided in the ornament kit and the attachment holes at the tip of this section. The electrical cord will be passed through the hollow tubing via a hole underneath the fourth section. Once the plug located at the end of the cord reaches the most vertical section of the arch, located near the middle of the assembly, the plug will fall through a hole and allow the user to connect the cord to an electrical outlet.

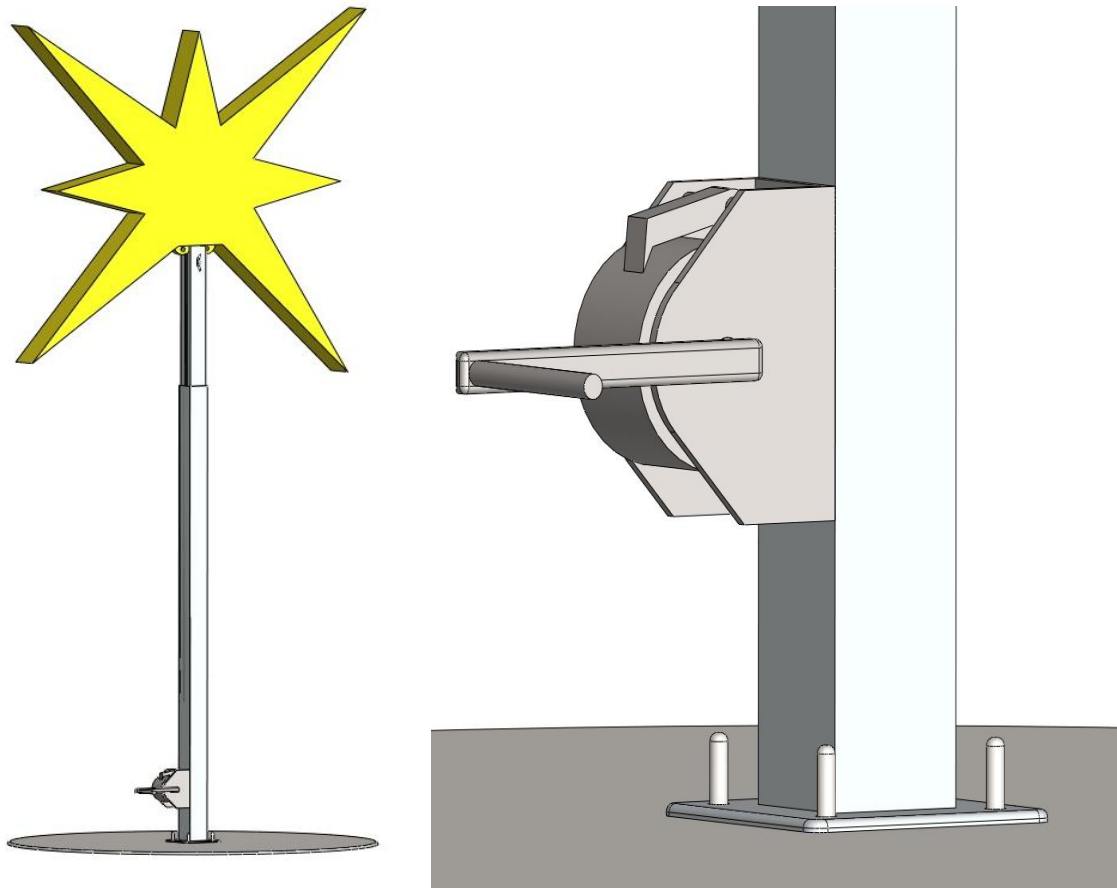

Figure 6: Design 3 – The Telescoping Light Post

The Telescoping Light Post is the only design that employs adjustable moving components and is comprised of two sections. The first is the base which secures the support post in the same way as the first two designs. This stand is designed to be collapsible to a height that is approximately half of the total height of the stand when fully extended. This collapsibility is accomplished by sliding the smaller top section into the bottom section. During assembly, the user will route the electrical cord down through the stand and out of a hole located at the base of the post. Then, the user must mount the ornament on top of the post using the provided rope and two small fastening cleats that are mounted on two opposing sides of the smaller top section of tubing. The post is equipped with a wench style crank that will shorten or lengthen a cable routed up the outside of the bottom section of tubing and inside of a crevice oriented along the length of the top section of tubing. This cable will be attached to the base of the top section of tubing so that when the cable is shortened, the top of the tubing will rise with the ornament attached to it. This assembly is very complex and will only be performed when the stand is manufactured. As such, the user's responsibility is only to feed the electrical cord through the hollow post and secure the ornament above.

During the concept selection process, Table 2 below was used to rank the top three design options based on 8 different criteria. These criteria helped to further differentiate the three designs. After speaking with the client, it was thought that The Telescoping Light Post design would be better suited for promotional applications and that the two arch designs would be better suited for consumer applications.

Table 2 ranked each design by column with a numbering system from 1 to 3 where 1 = best, 2 = better and 3 = good. These scores were assigned based on several preliminary assumptions regarding design performance should each design be manufactured and tested.

Table 2: Ranking design options from best to good

Design Option	Criteria							
	Assembly/Disassembly	Compact	lightweight	Height	Cost	Damage to Ornament	Life Expectancy	Recyclability
Telescoping Light Post	1	1	1	2	1	1	1	2
Sideways Arch	3	2	2	1	3	1	2	1
Festive Arch	2	3	3	1	2	1	2	1

Using the same eight criteria as before with their corresponding units, Table 3 applies a range of numerical values to each criterion which assists in setting an achievable goal for these criteria that can then be applied to each design. Once a goal value is set for each criterion, a value on a standard scale from 1 to 8 can be assigned with its corresponding performance level. Each goal is assigned a numerical raw score which corresponds to a standard score found in the Value column of Table 3.

Table 3: Criteria metrics used in design evaluation

Performance Level	Criteria Metrics								
	Value	Assembly/Disassembly [min]	Compact [ft ³]	Lightweight [lb]	Height [ft]	Cost [\$]	Damage to Ornament [\$]	Lifetime [yr]	Recyclability [%]
Perfect	8	< 10.0	< 1.5	< 20.0	≤ 12.0	< 300	0.00	≥ 10.0	≥ 90
Very Good	7	< 12.0	< 1.8	< 25.0	≤ 11.0	< 350	< 3.00	≥ 9.0	≥ 80
Good	6	< 15.0	< 2.0	< 30.0	≤ 10.0	< 400	< 5.00	≥ 8.5	≥ 70
Satisfactory	5	< 20.0	< 2.2	< 35.0	≤ 9.0	< 450	< 8.00	≥ 8.0	≥ 60
Adequate	4	< 25.0	< 2.5	< 40.0	≤ 8.0	< 500	< 10.00	≥ 7.5	≥ 50
Tolerable	3	< 28.0	< 2.8	< 45.0	≤ 7.0	< 600	< 15.00	≥ 7.0	≥ 40
Poor	2	< 30.0	< 3.0	< 50.0	≤ 6.0	< 700	< 20.00	≥ 6.5	≥ 30
Inadequate	1	> 30.0	> 3.0	> 50.0	≤ 5.0	> 800	> 40.00	< 5.0	≥ 20

Table 4 is generated from Table 3. The raw score is obtained from the range of numerical values for each criterion in Table 3. The values on the standard scale similarly relate to the

values in Table 3. Adding up the standard values, a total score is obtained from which a normalized score can be calculated. This is done by dividing the total score of each design by the sum of all the total scores. This decision matrix will assist in further design refinement, the goal of which is to obtain a single and best design option.

Table 4: Decision matrix

Criteria	Units	Design Options					
		Telescoping Light Post		Sideways Arch		Festive Arch	
		Raw Score	Value on Std. Scale	Raw Score	Value on Std. Scale	Raw Score	Value on Std. Scale
Assembly/Disassembly	min	15	6	25	4	20	5
Compact	ft ³	1.5	8	2.8	3	3.9	1
Lightweight	lb	43	3.5	45	3	49	2.1
Height	ft	10	6	12	8	12	8
Cost	\$	500	4	400	6	450	5
Damage to ornament	\$	0	8	0	8	0	8
Lifetime	yr	10	8	10	8	10	8
Recyclability	%	90	8	90	8	90	8
Total			51.5		48		45.1
Normalized Total			0.356		0.332		0.312

After speaking with the client and discussing the top 3 designs previously mentioned, the Sideways Arch was chosen to be the best design option. Although the Sideways Arch did not receive the highest score in the decision matrix, because money and time were both factors in this project, the Sideways Arch was decided on by the client to be a good compromise between a promotional and consumer display stand. To design and build 2 separate stands, one better suited for promotional purposes and the other for consumer purposes, would require more time and money than what is available.

MODIFICATIONS TO SIDEWAYS ARCH DESIGN

Initially, the display stand was being designed to accommodate one star. The client mentioned from the beginning that the structure would only display one ornament at a time and to design accordingly. Based on feedback received from the presentation on concept generation and selection, it was asked of the client if having multiple stars hung at the same time from the same ornament stand had ever been considered. The client responded positively and thought having the ability to hang multiple ornaments would make the stand more versatile and would be a better use of resources. The design was quickly modified to accommodate 3 ornaments and underwent several changes.

The first and obvious change was to create two other holes on the underside of the arch so that two additional electrical cords could be threaded through the hollow cross section. The rectangular geometry of the arch was changed to a square cross section for reasons discussed later in the section MATERIALS AND GEOMETRIES CONSIDERED. The circular base was cut in half to increase portability and allow both sections to be completely separated when not assembled. This did not necessarily decrease the overall weight of the base but rather facilitated the carrying of each half separately. Two hinges will be welded on to the base and secured with a locking pin when assembled. This locking pin can be easily removed for disassembly. Another hinge was added that attaches the bottom of the arch to the circular base itself. This hinge facilitates rotation of the arch so that it can be setup on the ground horizontally and pivoted into a vertical position where it will be secured to the circular base. Three studs fasten the hinged plate to the bottom of the arch and another two studs fasten the hinged plate to the circular base.

ENGINEERING ANALYSIS

To analyze the display stand, a full-scale model in SolidWorks was designed that could then be used to determine the mass properties of the entire structure. Through SolidWorks, the center of mass and the moments of inertia were generated which aided in finding the reaction forces at the base. From these forces, the stresses induced in each section of the structure due to loading can be found. A static analysis of the structure, neglecting the wind force, was performed which involved summing moments about the base to find the reaction force. The surface area of one side of each arch section was found based on the dimensions of the tubing used to construct the arch. This will become important when analyzing the force due to wind on the stand which will be a maximum when the wind is impacting the stand perpendicularly from either of the two symmetric sides, assuming that the wind will only impact one side at a time. The structure is divided into four sections and each section contributes to the reactions at the base relative to the section weight and the location of that section with respect to the base. For this analysis, three of the largest ornaments were considered (assuming the worst-case scenario) to approximate the maximum static load that this structure will experience. This type of scenario is not anticipated due to the client's intention of only displaying one of each size ornament at any given time. The values obtained from the SolidWorks model are listed below.

Some of the assumptions considered in the analysis of this structure are:

- Unidirectional wind flow
- Wind speed will not exceed 50 mph
- The aerodynamic analysis will model the ornament as a sphere
- Ambient temperature during use will not exceed 100°F
- Maximum of three ornaments displayed at any one time
- Uniform thermal expansion due to uniform material thickness and composition
- Force due to wind acting on the base is negligible

Center of mass measured from the center of the base

With x being the horizontal coordinate and considered positive moving towards the curve of the arch in the latitudinal direction, the center of mass COM_x location is 11.32 inches away from the center of the base.

With y being the vertical coordinate and considered positive moving longitudinally towards the tip of the arch, the center of mass COM_y location is 17.52 inches above the center of the base.

With z being the depth coordinate and considered positive when pointing away from the arch when the concavity opens to the right side, the center of mass location COM_z is 0.00 inches as it is symmetric about the vertical plane which intersects the arch halfway through the cross section of the tubing.

Top Section of the arch structure

Force due to weight (including the 3 largest ornaments) $F_{wt} = 6.93$ lb

Distance from the force due to weight to the center of the base $D_{fwt} = 63.68$ in

Surface area of one side $A_{st} = 185.44$ in²

Middle Section of the arch structure

Force due to weight $F_{wm} = 4.92$ lb

Distance from force due to weight to the center of the base $D_{fwm} = 72.22$ in

Surface area of one side $A_{sm} = 129.33$ in²

Bottom section of the arch structure

Force due to weight $F_{wb} = 21.12$ lb

Distance from force due to weight to the center of the base $D_{fwb} = 70$ in

Surface area of one side $A_{sb} = 192.52$ in²

Base of the entire structure

Force due to weight $F_{wbase} = 52.49$ lb

Diameter of base $D_{base} = 47.75$ in

Surface area of the base bottom $A_{base} = 1825.64$ in²

In performing the static analysis of this structure, the weight of the ornament acting directly above the center of the base will not cause a moment and therefore was neglected in the moment Equation 1.1. Summing the moments about the origin located at the center of the base, where clockwise is considered positive, the following equation was obtained.

$$\sum M_o = F_{wt}(D_{fwt}) + F_{wm}(D_{fwm}) + F_{wb}(D_{fwb}) + R_{base}(D_{base}/2) = 0 \quad (1.1)$$

All of the values in Equation 1.1 are known with the exception of R_{base} which can be found by solving Equation 1.1. This reaction of the base is located at the outermost edge located directly behind the extrusion on the base of the arch. This edge will provide the reaction force needed to stabilize the structure and is found to be.

$$R_{base} = 60.9806 \text{ lb}$$

This force resists the tendency of the arch to rotate about the center of the base assuming that the base of the structure can withstand the stress induced by this force. If this is true, then the base design is sufficient. This stress will be calculated using the following Equation 1.2.

$$\sigma = \frac{M(y)}{A(e)(r_n - y)} \quad (1.2)$$

Where:

σ = stress

M = moment

y = distance from the neutral axis to the outer fiber of the cross section

e = distance from the neutral axis to the centroidal axis

A = cross sectional area

r_n = distance from the origin to the neutral axis

Once the stress induced on the structure is calculated at different locations, it can be determined whether or not the current material will withstand the loading that will occur. In the event that the current material is not strong enough to withstand the forces it will be subjected to, a stronger material will need to be selected that may have a higher density and or cost more.

Another important engineering analysis that must be considered is one that involves the environmental effects on the structure during use. The effects considered in the analysis are wind, temperature and precipitation. The primary focus of the environmental effects will be on the forces due to wind as the selected material is resistant to corrosion. Also, because the structure is composed of the same material throughout, the stresses induced due to varying temperatures will be neglected as mentioned in the assumptions.

To analyze the force due to wind, the surface areas of the sides of the arch sections were considered as these sections will experience the most force and cause the most stress in the structure. The force will be approximated assuming that a maximum wind speed of 50 mph. This maximum wind speed was found from data provided by the National Oceanic and Atmospheric Administration (NOAA) for Flagstaff, Arizona [5]. This location is assumed to be sufficient for all of Northern Arizona as it is within a 60 mile radius of the primary usage area. The force due

to wind is calculated using Equation (1.3).

$$F_w = A * P * C_d \quad (1.3)$$

Where:

F_w = total force due to wind

A = projected area of object

P = wind pressure

C_d = drag coefficient

To perform this analysis, the entire surface area of one side of the 3 sections of the arch must be summed because the wind will impact the entire surface. Based on this analysis the force was found to be.

$$F_w = 35.23 \text{ lb}$$

Where:

$C_d = 1.0$ for flat plates

$P = 0.004 * V^2$ (V = wind speed in mph) = $0.004 * 50^2 = 10.0$ psf

$A = 3.523 \text{ ft}^2$.

When the forces are analyzed using the same method that was used to find the reaction force for the weight of the arch, an equation similar to Equation 1.1 can be implemented to find the reaction force, R_w , necessary to prevent instability. Using SolidWorks to find the centroid of the arch with x being the horizontal coordinate and considered positive moving towards the curve of the arch in the latitudinal direction, the center of mass COM_{xa} location is 27.65 inches away from the center of the base.

With y being the vertical coordinate and considered positive moving longitudinally towards the tip of the arch, the center of mass COM_{ya} location is 17.81 inches above the center of the base.

To find the distance from the centroid of the arch to the center of the base the Pythagorean Theorem, Equation 1.4, can be used.

$$D_{ca} = \sqrt{COM_{xa}^2 + COM_{ya}^2} \quad (1.4)$$

Where clockwise is considered positive. Equation 1.5 can be used to solve for R_w .

$$\sum M_o = F_w(D_{ca}) + R_w(D_{base}/2) = 0 \quad (1.5)$$

Where:

D_{ca} = distance of the centroid of the arch to the center of the base

R_w = reaction force at the edge of the base

The reaction force is found to be

$$R_w = 31.22247 \text{ lb}$$

The same equation, Equation 1.2, can be used to find the stress induced by this force which will be used to determine whether or not the material and dimensions selected are sufficient.

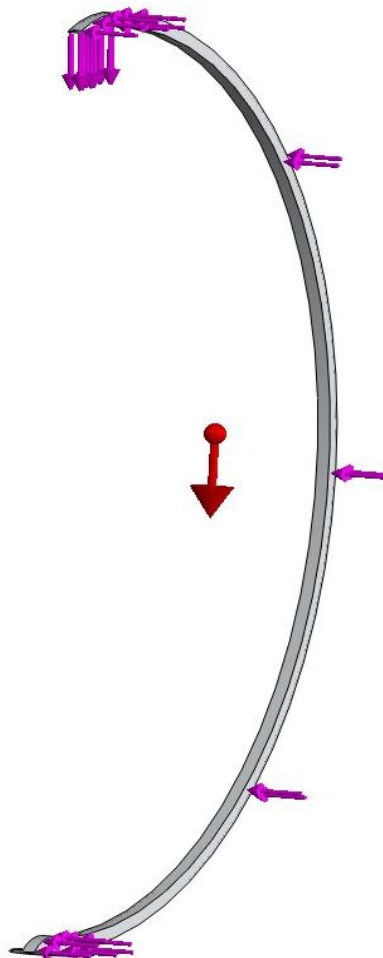

Figure 7: Force analysis using SolidWorks

35.23 pounds was used for the total wind force which comes from the value obtained using Equation 1.3 above. The combined weight of the largest 3 ornaments came to approximately 22 pounds ($7.19 \text{ lb} * 3 = 21.57 \text{ lb}$) and was concentrated at the tip to represent the worst-case scenario.

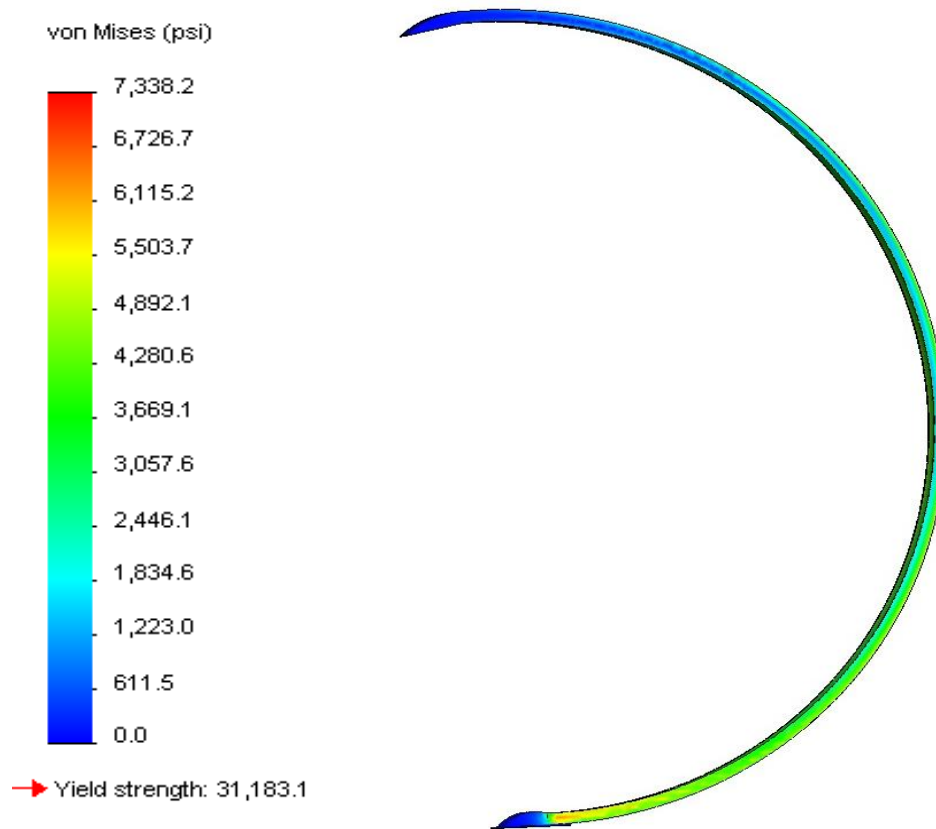

Figure 8: Stress analysis using SolidWorks

The stress analysis for this structure was performed using the Von Mises failure theory; this was used because this failure theory accounts for the principal stresses that occur. The diagram shows that the maximum stress will occur at the base of the structure as predicted. The stress is maximized at this point due to the structure being supported at this location only. Stress is minimal at the highest end because this location does not have the ability to resist deflection as it is not secured. Although the ornaments will be hung from the highest end of the structure this does not result in stress at that location, instead, that stress is translated through the arch and results in the maximum stress at the base. The yield strength listed under the legend is much larger the maximum stress induced in this structure; therefore, it is appropriate to assume that no permanent or plastic deformation will occur in this structure.

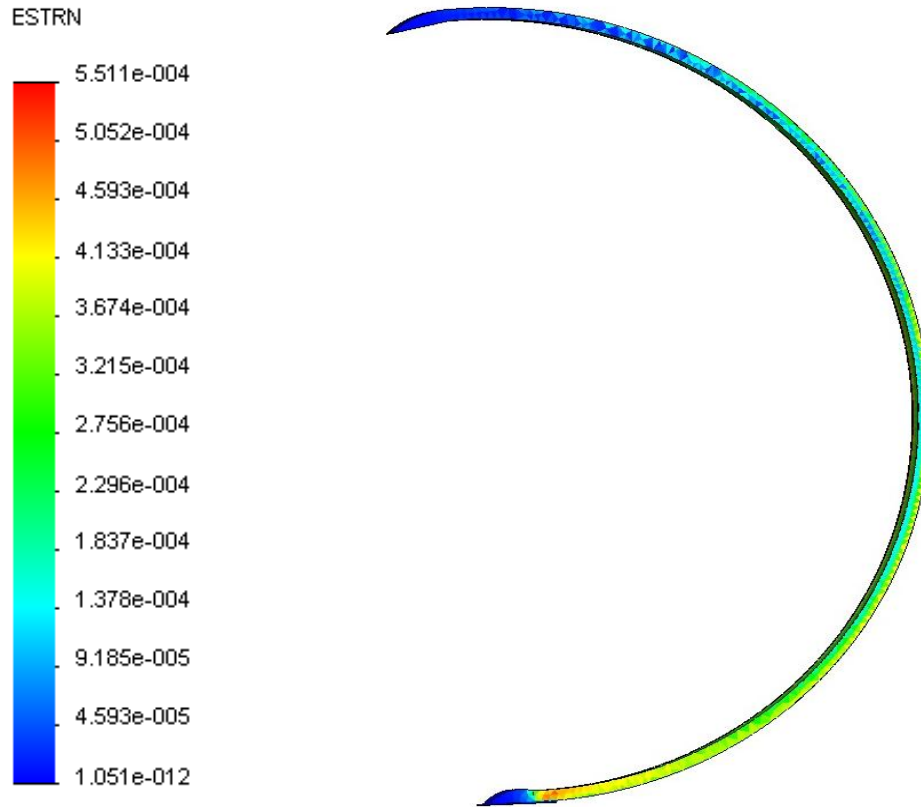

Figure 9: Strain analysis using SolidWorks

This analysis employs the same legend colors as the stress diagram with the maximum strain occurring, again, at the base. Strain is the measurement of deformation due to stress; it is a quantity without units due to the actual units being $\frac{psi}{psi}$ for this study. Although there is no limiting criteria for strain, the limiting criteria for stress can be employed to establish that if the stress is not larger than the yield strength then the resulting strain will also be within an acceptable tolerance.

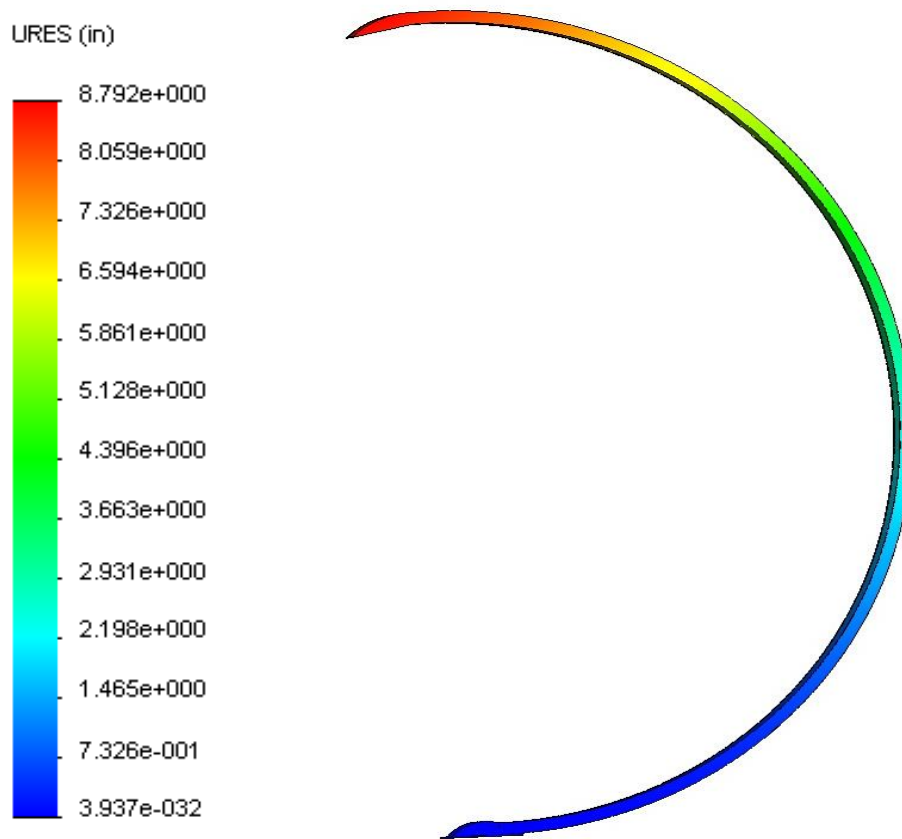

Figure 10: Deflection analysis using SolidWorks

The deflection for this structure being close to nine inches may seem excessive; however, when the deflection is represented as it is in this analysis, it must be understood that the reported deflection is the resultant deflection. The resultant deflection is the deflection in the vertical direction due to the weight of the ornaments with the added deflection from the wind force in the horizontal direction. This deflection is found by taking the square root of the sum of the two deflections squared individually. Also, when considering that the structure is approximately 140 inches in height, a 9 inch resultant deflection is not very significant.

FINAL DESIGN

MATERIALS AND GEOMETRIES CONSIDERED

The only materials considered for this design were steel and aluminum. Strength, weight and cost heavily influenced the material selection as they were all factors listed in the project objectives and constraints. In general, aluminum is more expensive than steel except in the case of stainless steel which contains chromium and sometimes nickel. Both are relatively rare elements when compared to aluminum and therefore more costly. From a cost perspective, steel was more attractive; however, steel is about 3 times heavier than aluminum. Because the project budget is flexible and because light weight is one of the constraints, aluminum seemed to be the

better choice. Aluminum provides the stiffness required (steels modulus of elasticity is about 3 times as much), the corrosion resistance needed, is much lighter than steel, and readily available with the most significant downside being cost. It was determined that the advantage of aluminum outweighed the disadvantages and was decided on instead of steel with the project objectives and constraints in mind.

Several geometries were considered for the different components of the arch and base. These geometries include square, rectangular and circular cross sections. The circular section was initially ignored because the square and rectangular cross sections were thought to be more visually appealing. Another reason the square and rectangular sections were more favored was because a hinge could more easily be attached due to a flat surface. After talking with the client about the three possible cross sections, preference was given to the rectangular geometry. However, if there was a significant difference in cost between square and rectangular geometries, the cheaper one would be favored. After doing some price comparisons online between the 3 similarly dimensioned aluminum cross sections using the same websites for each one, it was found that the rectangular and square tubing was either cheaper or not significantly different than the round tubing [6], [7]. Significantly different in this case means greater than \$30.00. Between the rectangular and square cross sections, it was found, based on some research that aluminum square geometries are cheaper to manufacture and therefore cost less for use in this design [10]. For this reason, a square cross section for the arch was chosen made of 6063-T6 aluminum for its lightweight, corrosion resistance and formability.

For the base itself, only square and circular geometries were considered due to user safety and aesthetics. With a circular base, there would be no pointed edges and it looks more visually appealing. A circular base was chosen for these reasons. The base was selected to be made out of 3003-H14 aluminum due to its excellent weldability, formability, good corrosion resistance as well as a smooth shiny finish.

COST ANALYSIS

The first 2 rows in Table 5 represent the square aluminum tubing that will be used in the arch sections. Two 8 foot sections and one 6 foot section was considered for a total of 22 feet which is 16.67% more than what is needed. Additional tubing was accounted for to allow for mistakes that may occur during the manufacturing stage. The third row represents the aluminum plates that will be used to construct the 2 halves of the base. Buying 2 smaller plates as opposed to one larger plate which would require further modification was found to be less expensive for the base material. The fourth row represents the aluminum hinge plate that will be used to connect the bottom of the arch to the base itself.

Table 5: Cost estimates for raw materials, studs, pins and cleats

Qty	Item Description	Size (w x h x t)	Length	Price (each)	Total Cost
2	6063-T52 Square Aluminum Tube	2 x 2 x 0.125	96	\$62.80	\$125.60
1	6063-T52 Square Aluminum Tube	2 x 2 x 0.125	72	\$47.10	\$47.10
2	3003-H14 Aluminum Plate	24 x 48 x 0.25	48	\$171.04	\$342.08
1	3003-H14 Aluminum Plate	12 x 24 x 0.25	24	\$42.76	\$42.76
		Size (D)			
2	18-8 Stainless Steel Quick Release Pin	0.25	6	\$2.84	\$5.68
2	Zinc-Plated Steel Quick Release Pin	0.25	4.5	\$2.39	\$4.78
4	PSL2-04-4CN, Type PSL2 Spring-Loaded Plunger Carbon Steel	0.51 (base) 0.25 (pin)	0.78	\$1.36	\$5.44
6	S-D-046104-1 Sea Dog Closed Base Die-Cast Aluminum Cleat		4	\$3.49	\$20.94
4	Type FH4 Flush Head Stud Stainless Steel	0.138	1.25	\$0.11	\$0.44
				Sales Tax	\$0.55
				Shipping	\$19.70
				Final Cost	\$615.07

All dimensions are in inches

w = width, h = height, t = thickness, D = diameter

Sales tax only applies to products bought in Arizona

CAD DRAWINGS AND GEOMETRY DIMENSIONS

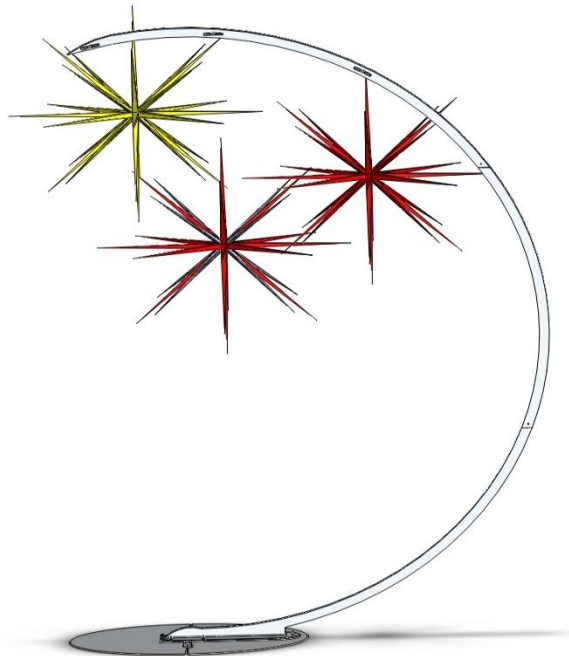

Figure 11: Sideways Arch with the 3 largest ornaments shown

Figure 11 illustrates what the Sideways Arch design will look like when fully assembled and with 3 ornaments hanging from it.

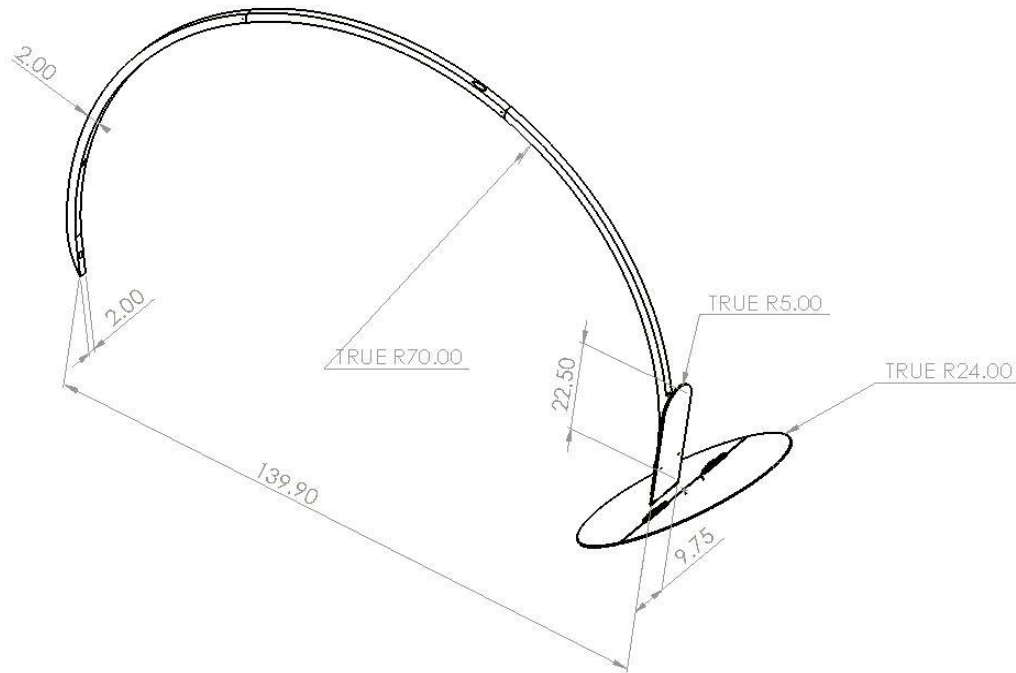

Figure 12: Sideways Arch during arch assembly with dimensions

All dimensions shown are in inches. The center of the base plate which was referred to in the ENGINEERING ANALYSIS section includes both male and female halves when assembled as shown in Figure 12, 17, and 18.

The Sideways Arch design satisfies all the objectives and constraints mentioned previously in the problem statement except for those that will have to be tested in the prototyping stage. The durability and reliability may be difficult to test however in the amount of time available for this project with regards to the stand's lifespan and how frequently maintenance is required. Other objectives and constraints that will require testing in the coming months include assembly time and portability.

Of the objectives that can be tested, the stand is over 90% recyclable which satisfies the objective of recyclability. As far as the display stand being inexpensive, although the goal of the stand costing less than \$500.00 was exceeded in raw materials alone, the budget set forth by the client has not been surpassed. The project is still on track to be delivered within the budget of around \$1000. With the current dimensions, the display stand will be able to elevate the largest ornament at its highest point around 8 feet measured from the ground to the ornament's base. The other two ornaments will be elevated at least 6 feet which satisfies the first constraint. The second constraint is satisfied because the heaviest component, one half of the base, weighs in at about 22 pounds which is far less than the 50 pound maximum. Using the cleats located at the top section of the arch, all three ornaments will be hung satisfying the third constraint. The

current design is able to support 3 of the largest sized ornaments hung at the same time and therefore satisfies the fifth constraint. The last constraint is satisfied because once assembled, the Sideways Arch needs no additional support from any person or structure.

FUTURE TASKS

The first step in prototyping is to obtain the materials needed to begin manufacturing which includes all of the hardware required for assembly like nuts, bolts, washers, pins, fasteners, hinges, dock cleats and bulk material.

Once all of the required materials are gathered, the manufacturing process can begin. The first step in the manufacturing process is to create a manufacturing map, a detailed outline of how the manufacturing process will occur, so that the modification of these materials is performed as efficiently and easily as possible. For instance, it may be easier to bend the tubing at its full length rather than cut it before bending.

After a manufacturing map is created to aid in determining what order each component should be modified or created, the machining process can begin.

This manufacturing process may occur as follows:

1. Bend three sections of aluminum tubing to a radius of 70 inches.
2. Remove excess material from the length of the aluminum tubing in sections yet to be determined.
3. Modify the top section of aluminum tubing which requires that several holes be bored into it for locking pins and electrical connectivity. Also, the tip of this section will need to be shaped so that the end is not a blunt square.
4. Modify the middle section of aluminum tubing which requires that several holes be bored into it for locking pins and electrical connection retrieval.
5. The hinge plate requires that it be cut from a rectangular sheet of aluminum in the shape of a long rectangle with one rounded end.
6. The hinge plate will then need three *PEM studs mounted onto it, two located near the shortest straight edge of the hinge plate and one in the center of the curved section offset closer to the edge.
7. Modify the lower arch section of aluminum tubing which requires that a base plate be welded to the end opposite the locking pins. Also, this end of the tubing must be rounded so that it too is not a blunt square.
8. The base will require preliminary modification as well. This modification includes removing excess material from the two rectangular plates to create two identical semicircular plates. The edges of these plates will also need to be rounded to prevent user injury.
9. One half of the base will then require that two hinges be welded onto its face to facilitate the hinge plate attachment.
10. One half of the base will require that two *PEM studs are mounted on its face to facilitate securing the hinge plate once the structure is fully assembled.

11. The two semicircular plates will then be mated at their two straight edges and once placed on a perfectly smooth surface an open hinge will be placed over the span of the seam between the two plates and welded in place securing the two halves of the base plate together. See Figure 18.
12. The lower section of aluminum tubing with the base plate attached will then be placed in position on the hinge plate and secured.
13. The hinge plate will be placed in position on the base and welded to the hinge attached to one half of the base.
14. Once in position, the lower section will be hinged upward placing the hinge plate on the aforementioned studs that have been mounted in the base. This will create a small impression in the aluminum and indicate exactly where the holes must be drilled so that the studs can penetrate through the plate.
15. After the lower arch section and base are fully assembled, short cross sections of aluminum recovered from the excess material that was cut off from the tubing will be cut along the edges resulting in four flat plate sections that will be welded to the inside of the square opening in the end of the tubing. This will facilitate the interlocking between sections at the spring loaded pins. These plates will then be welded at the edges for added stability and strength.
16. The middle section of aluminum tubing will then be attached to the lower section by inserting the previously created joint. Once the section is in place, a punch will be used to mark the center of the hole through which the spring loaded locking pin must pass. This hole will serve as an indicator for where to drill the holes and install the locking pins.
17. The top section will be attached to the middle section in the same fashion that the middle section was attached to the lower section using recovered material and marking.
18. Once the top section is attached and all components are secured, the ornaments will be hung from the stand and the best location for the dock cleats will be determined by finding the location that is most favorable for the electrical connection and stability of the ornaments. These locations will be marked using a permanent marker to outline an image of the cleat base on the two sides of the section.
19. The top section will then be disassembled and the dock cleats will be mounted onto the two sides of the top section of the arch in the corresponding locations.
20. The stand is now complete and can be tested.

*PEM is a registered Trademark of Penn Engineering and Manufacturing

The testing will begin by loading the stand as indicated in Figure 7 using an industrial fan to simulate wind and the actual ornaments to demonstrate the force due to gravity.

The following test will be to leave the stand outside with the ornaments in an open area such as a parking lot to determine how gusting or other environmental effects may influence the structure's performance.

Once these endurance tests are complete, the assembly time must be tested. First, the designers will test the stand by assembling it themselves recording the time required to do so. This will represent what the client can expect upon becoming more familiar with the structure and its construction.

The next test will employ people that are not intimately familiar with this project. These people will assemble the structure and be timed while doing so. This will represent the time required to assemble the display stand for a person without any knowledge of the structure's construction.

The display stand without ornaments will then be entirely disassembled and placed into the trunk or back seat of a compact car to test the transportability of the structure.

Then the final test will be to display the stand with the ornaments in a public place to observe the responses from people.

PROJECT PLAN

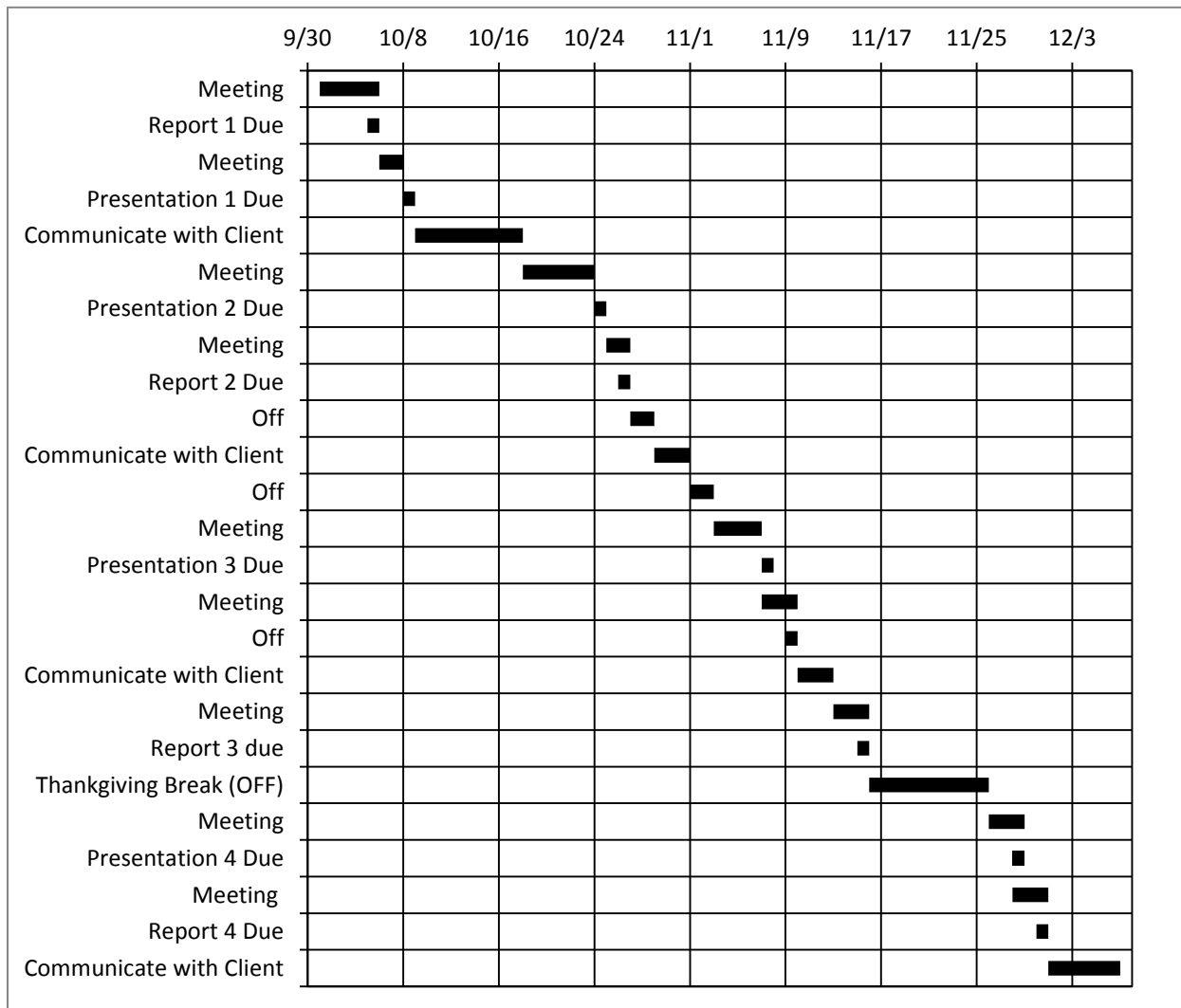

Figure 13: Project timeline for fall 2012

The project timeline in Figure 13 represents the milestone events that occurred throughout the design process. This graphical representation of a project timeline can be referred to throughout the design process and serves as a guide, ensuring that tasks are accomplished within the corresponding timeframe. The timeline features the milestone events on the left column with their corresponding timeframe in chronological order on the right. The longer bars represent the duration over which an event takes place while the shortest bars represent deadlines. The dates are represented at the top of this chart in a time scale of 8 day increments.

The first task achieved for this project involved brainstorming, coming up with as many design ideas as possible that would serve as a solution to the given problem. Some of the designs were just too costly to manufacture while others were deemed impractical and later thrown out. After brainstorming was complete, the designs were shown to the client and the top 3 were selected.

The second task was to narrow down the top 3 designs so that a final design could be chosen. This concept selection stage utilized a decision matrix, Table 4, criteria metrics table, Table 3, and 8 different criteria that were used to rank each of the 3 designs. In addition, the top 3 designs were again discussed with the client who critiqued each one and gave valuable feedback. Some designs were thought to be better suited for promotional applications while others better suited for customer applications. Because time and money did not permit for the design and building of multiple display stands, one design was ultimately decided on by the client that served as a compromise between the promotional and consumer aspects.

After a final design was selected, the third task was to choose the geometry and material(s) for the various components that made up the stand. Research was done to determine which material would be lightweight, strong, corrosion resistant, and would not be too expensive. Aluminum seemed to be the best material for the application and was chosen for all aspects of the stand. After much debate whether a circular, square, or rectangular cross section would be best for the arch sections, a square cross section was selected based on its formability, flat surfaces, cost, and aesthetics.

The fourth task was to then perform an engineering analysis which involved several calculations, equations and multiple SolidWorks simulations. Modifications to the final design took place before the analysis and are reflected in the calculations and simulation. Statics, mechanics of materials, dynamics, and machine design were all utilized to find the forces, stresses, strains, and deflections acting on the display stand. This analysis helped to determine if the selected material was strong enough to withstand the subjected stresses and forces.

The fifth task was to perform a cost analysis for the raw materials and fasteners which included pins, cleats and studs. Shipping and tax was included in this analysis and depended on which parts had to be ordered from out-of-state. Several companies were looked at for parts and materials to obtain the best price. These costs and estimates were compiled into a table and summed to generate an overall cost estimate for materials and hardware thus far. Manufacturing and processing costs were not accounted for in this analysis as the final design with dimensions and costs needed to be approved by the client and engineering analyses double-checked. Since

the cost analysis was performed, the final design and costs have been approved and quotes for manufacturing are currently being obtained.

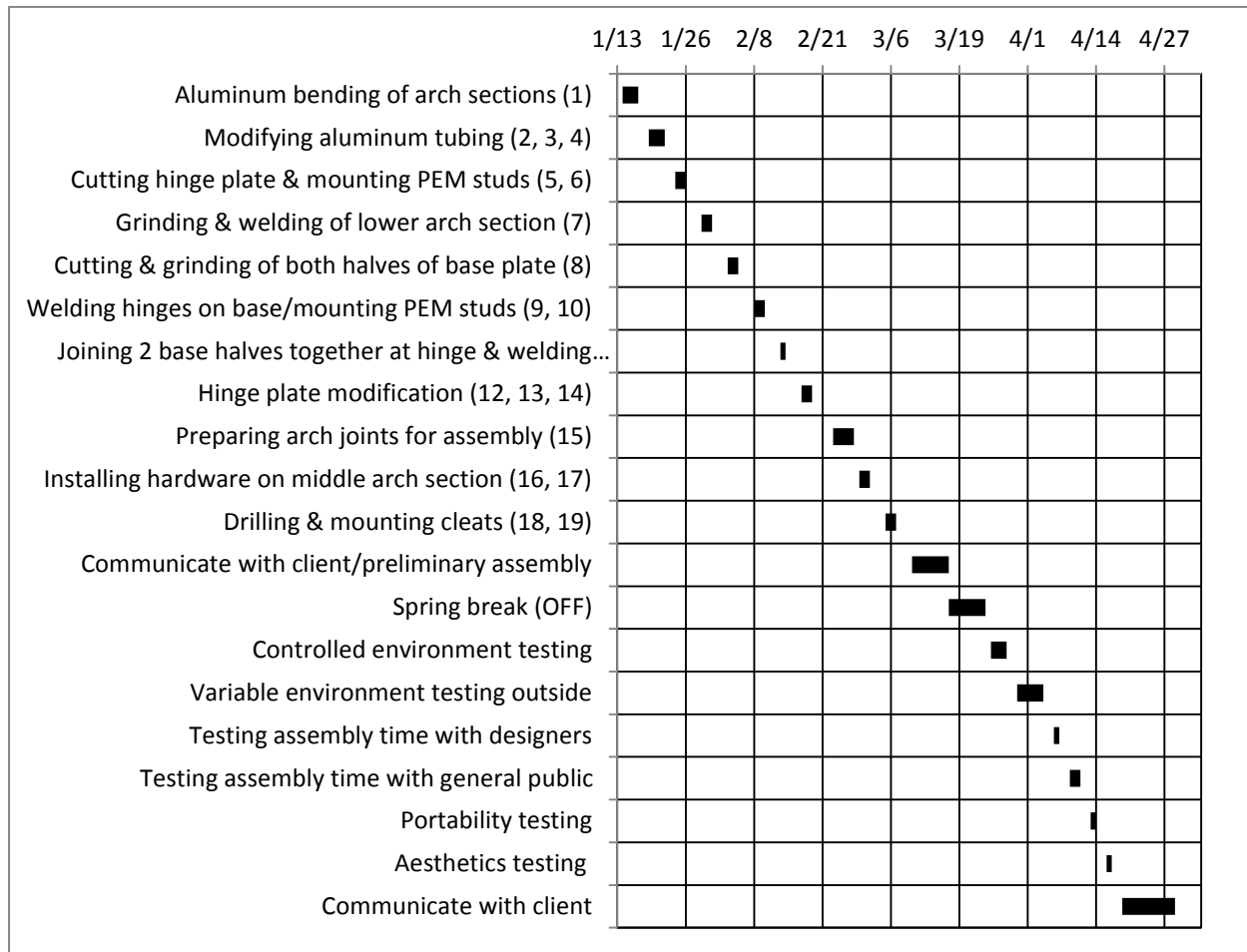

Figure 14: Project timeline for spring 2013

Figure 14 is a chronological representation of how the testing and manufacturing process will occur. The numbers in parenthesis following the tasks correspond to the step numbers contained in the FUTURE TASKS section above. This project timeline is tentative and allows 2 to 3 days between tasks for unforeseen problems that may occur.

CONCLUSION

My Star of Bethlehem LLC does not have an aesthetically pleasing way to display their Christmas ornaments to potential customers at various marketing locations and is requesting a display stand to assist in showcasing their ornaments. The goal for this project is to design an effective and visually appealing way to display the Christmas ornaments at marketing locations. The client's requirements were to have a portable, collapsible, light-weight, easy to setup and easy to take down display stand. The objectives for this stand are that it be:

- Inexpensive
- Easy to assemble/disassemble
- Durability
- No Damage to Star
- Recyclable
- Reliability

The constraints that the display stand has to adhere to are as follows:

- The ornament(s) need(s) to be elevated a minimum of six to eight feet above ground.
- The display stand must be light enough for one adult to carry.
 - Each individual component weighs less than 50 pounds.
- Ornament(s) needs to be hung or mounted.
- The stand assembly time must not exceed thirty minutes.
- The stand must support two different sized ornaments.
 - Medium size: diameter = 2.29 feet, weight = 2.94 pounds
 - Large size: diameter = 4.27 feet, weight = 7.19 pounds
- The structure needs to be free standing.

From the objectives and constraints, preliminary designs were generated during brainstorming. The designs generated were presented to the client and narrowed down to the top 3. The three designs were then categorized and analyzed with tables which included a decision matrix and criteria metrics which helped further refine the design options. These 3 designs were further discussed with the client and a final design was then chosen, the Sideways Arch. Originally, the Sideways Arch was designed to only support one ornament at a time. Later, the design was modified to accommodate up to 3 ornaments and to make the assembly easier. Once the modifications were completed, material chosen and geometries selected, the engineering analysis could be performed. To perform this analysis, many assumptions were made in order to make the calculations more manageable. When performing the analysis, the focus was on the stresses that would be induced in the structure during usage. Based on these stresses, the success

or failure of the structure operating under normal conditions can be determined. The stress and force analysis demonstrated that the Sideways Arch can endure the loads applied without failure. The final design satisfies both the needs and constraints set forth by the client and will present the ornaments in a visually pleasing manner as intended. Figure 14 illustrates the order that the manufacturing process for the Sideways Arch will occur in.

REFERENCES

- [1] Budynas, R. G., & Nisbett, J. K. (2010). *Shigley's mechanical engineering design*. (9th ed.). New York, NY: McGraw-Hill Science/Engineering/Math.
- [2] Hibbeler, R. C. (2012). *Structural analysis*. (8th ed.). Upper Saddle River, NJ: Pearson Prentice Hall.
- [3] afi Assembly Fasteners Inc. (n.d.). *Type PTL2 & PSL2 Spring-Loaded Plunger Assemblies (Unified)*. Retrieved from <http://afi.thomasnet-navigator.com/item/all-categories/tl2-psl2-spring-loaded-plunger-assemblies-unified-/psl2-04-4cn?&plpver=10&origin=keyword&filter=&by=prod>
- [4] Andress, K. (2002, March 03). *Wind loads*. Retrieved from <http://k7nv.com/notebook/topics/windload.html>
- [5] Delinger, Dan. (2008, August 20). *Wind- maximum speed- (mph)*. Retrieved from <http://www.ncdc.noaa.gov/oa/climate/online/ccd/maxwind.html>
- [6] MetalsDepot. (2012). *Aluminum rectangle tube*. Retrieved from [http://www.metalsdepot.com/products/alum2.phtml?page=aluminum rectangle tube&LimAcc= &aident=](http://www.metalsdepot.com/products/alum2.phtml?page=aluminum%20rectangle%20tube&LimAcc=&aident=)
- [7] MetalsDepot. (2012). *Aluminum square tube*. Retrieved from <http://www.metalsdepot.com/products/alum2.phtml?page=tube&LimAcc=%20&aident=>
- [8] McMaster-Carr. (n.d.). *Quick-Release Pins*. Retrieved from <http://www.mcmaster.com/#stainless-steel-quick-release-hitch-pins/=kclu42/>
- [9] Otte, Dieter. (2012). *My Star of Bethlehem; The Star That Keeps on Giving*. Retrieved from <http://mystarofbethlehem.com/>
- [10] Smith, B. (2002, May 16). *Bending square and rectangular tubing*. Retrieved from <http://www.thefabricator.com/article/tubepipefabrication/bending-square-and-rectangular-tubing>
- [11] Wholesale marine. (2011). *Sea Dog Closed Base Aluminum Cleat*. Retrieved from [http://www.wholesalemarine.com/p/S-D-046104-1/Sea Dog Closed Base Aluminum Cleat.html](http://www.wholesalemarine.com/p/S-D-046104-1/Sea-Dog-Closed-Base-Aluminum-Cleat.html)

APPENDIX: ADDITIONAL DISPLAY STAND FIGURES

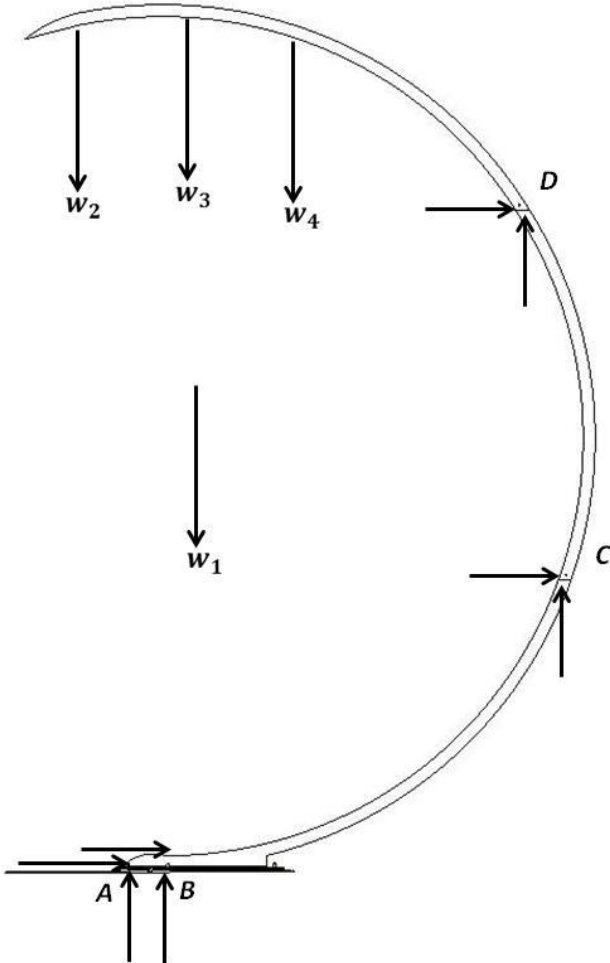

Figure 15: Free body diagram of display stand

The two forces at A and B in Figure 15 represent the reactions of the hinge plate/arch fastening studs and the hinge plate/base fastening studs. The location C represents the reactions at the pin attaching the bottom section to the middle section of the arch. The location D represents the reactions at the pin attaching the middle section to the top section of the arch. The weights of the ornaments are shown by the vectors at the top of the arch as w_2 , w_3 , and w_4 . The overall weight of the display stand is represented by w_1 which originates at the centroid of the entire structure.

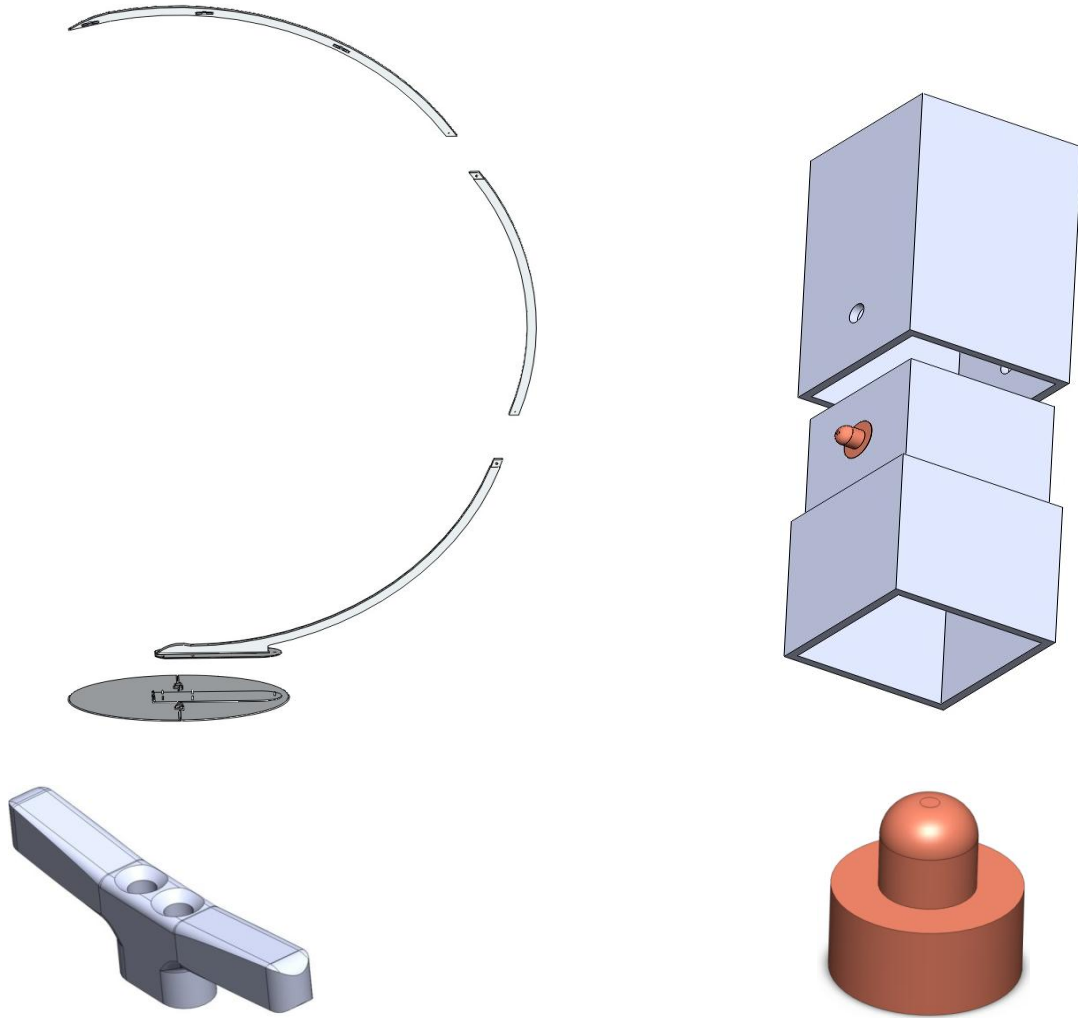

Figure 16: Exploded views of Sideways Arch

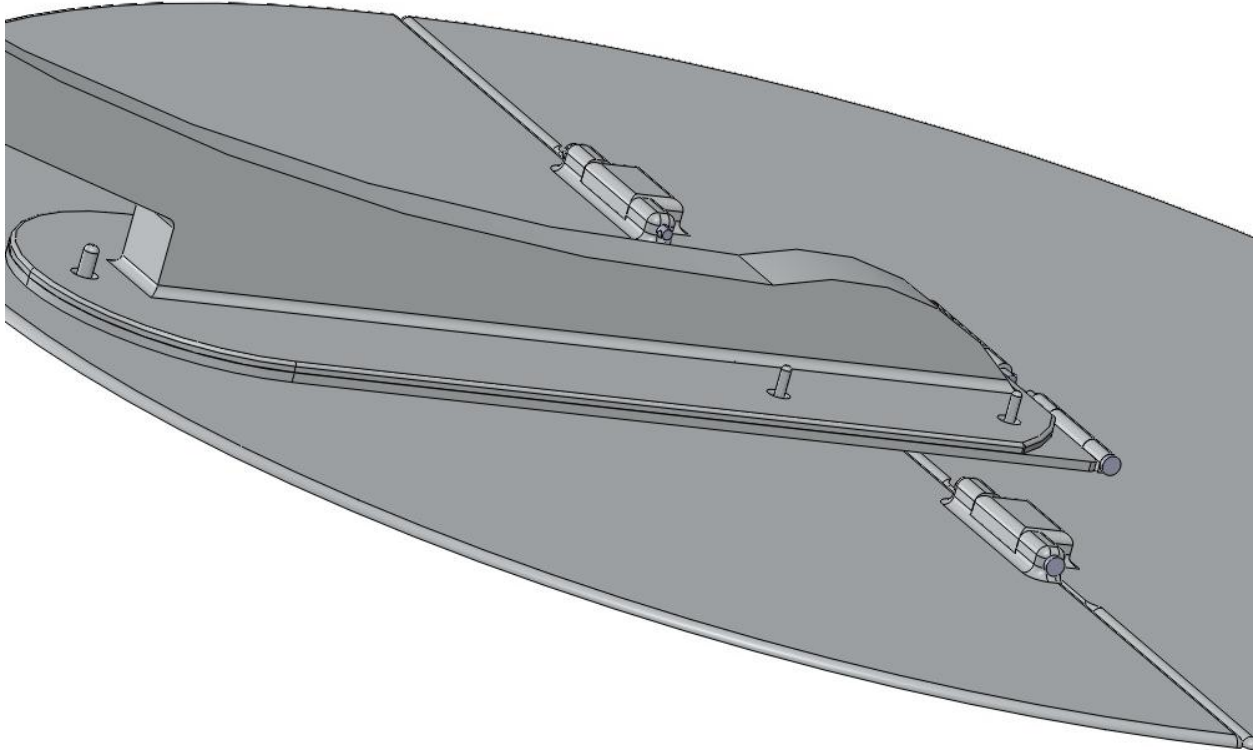

Figure 17: Modification –arch base attached to hinge plate

Figure 17 illustrates how the bottom section of the arch will attach to the hinge plate. Three studs, 2 in the front near the hinge and 1 in back, will facilitate the attachment. Another 2 studs just in back of the 2 near the hinge attach the hinge plate to the base. See Figure 18 for another view.

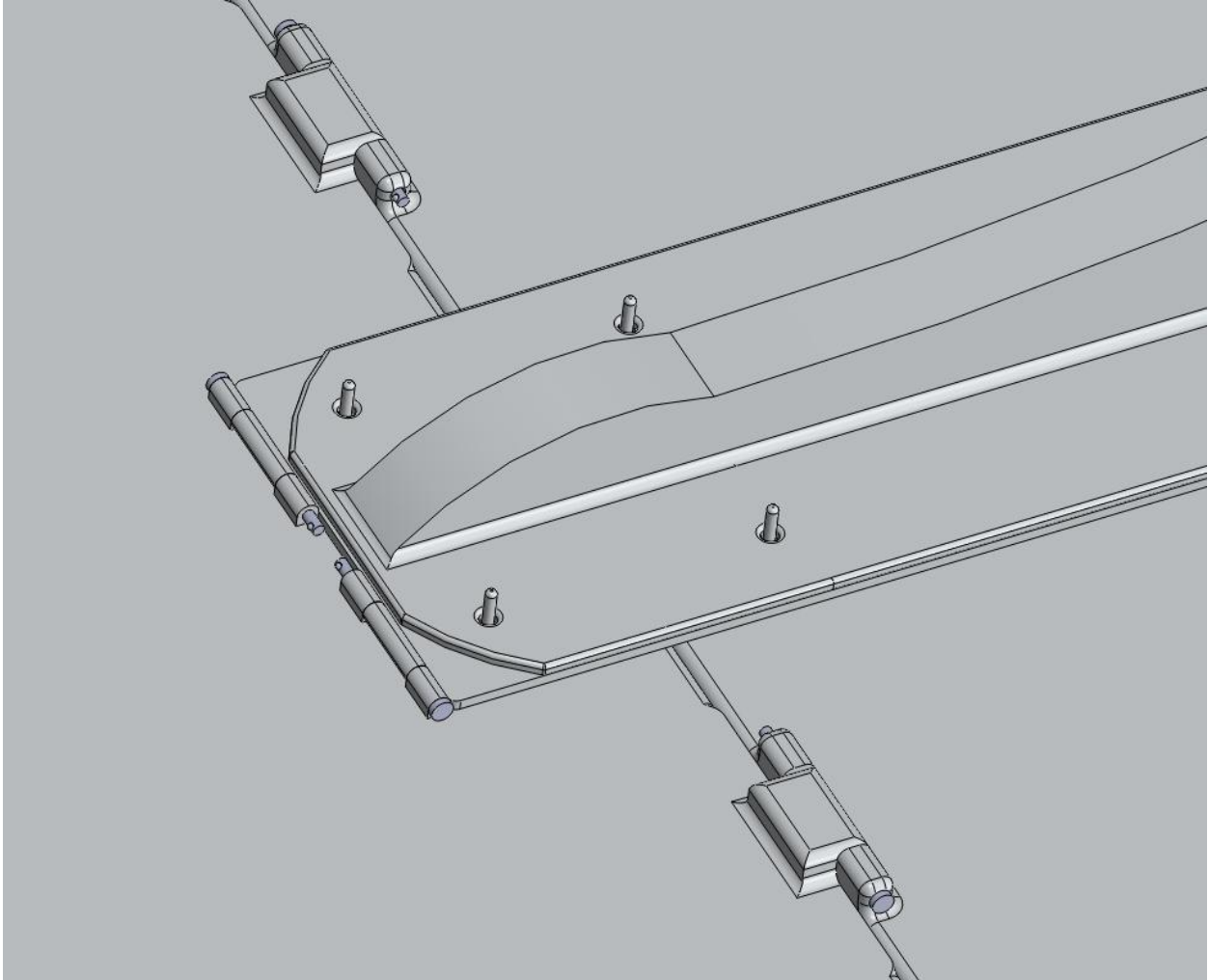

Figure 18: Modification – front/top view of arch base attached to hinge plate