

इंटरनेट

मानक

Disclosure to Promote the Right To Information

Whereas the Parliament of India has set out to provide a practical regime of right to information for citizens to secure access to information under the control of public authorities, in order to promote transparency and accountability in the working of every public authority, and whereas the attached publication of the Bureau of Indian Standards is of particular interest to the public, particularly disadvantaged communities and those engaged in the pursuit of education and knowledge, the attached public safety standard is made available to promote the timely dissemination of this information in an accurate manner to the public.

“जानने का अधिकार, जीने का अधिकार”

Mazdoor Kisan Shakti Sangathan

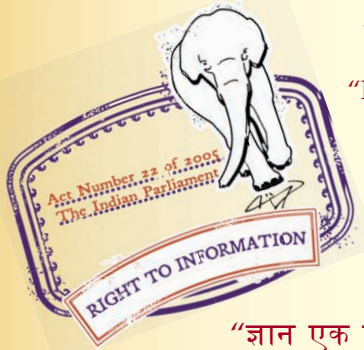
“The Right to Information, The Right to Live”

“पुराने को छोड़ नये के तरफ”

Jawaharlal Nehru

“Step Out From the Old to the New”

SP 46 (2003): Engineering Drawing Practice for Schools and Colleges [PGD 24: Drawings]



“ज्ञान से एक नये भारत का निर्माण”

Satyanarayan Gangaram Pitroda

“Invent a New India Using Knowledge”



“ज्ञान एक ऐसा खजाना है जो कभी चुराया नहीं जा सकता है”

Bhartrhari—Nitiśatakam

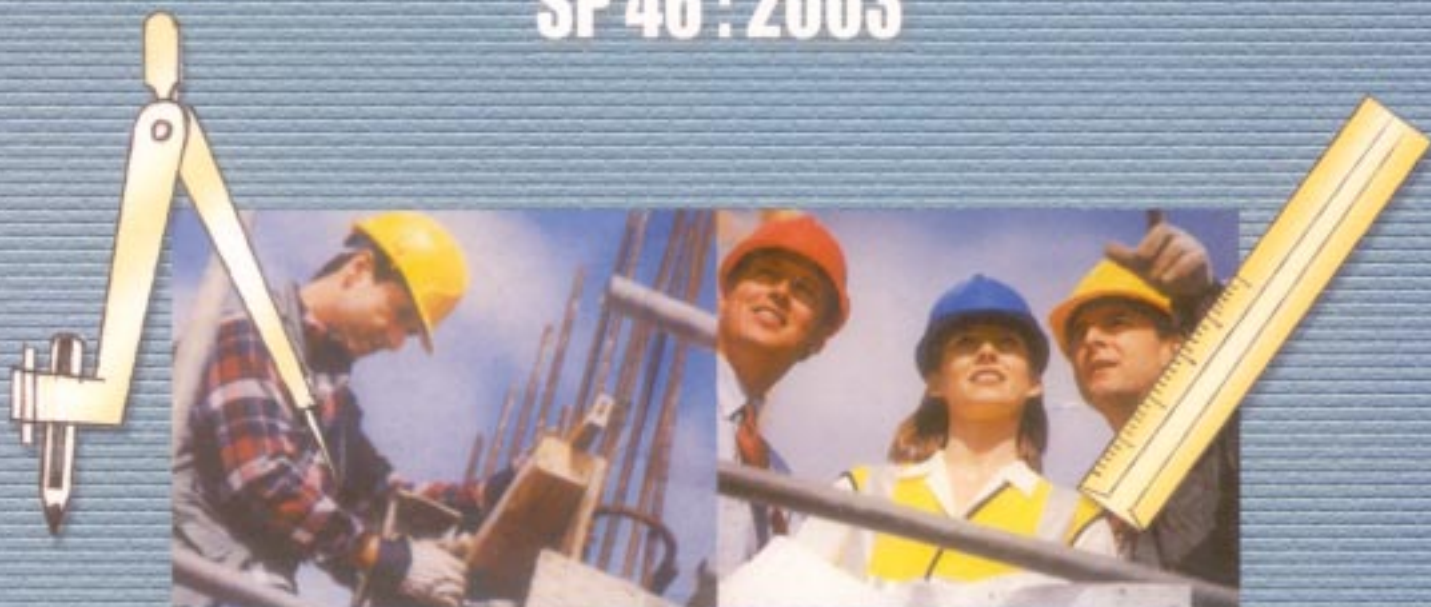
“Knowledge is such a treasure which cannot be stolen”

BLANK PAGE



Engineering Drawing Practice for Schools & Colleges

SP 46 : 2003



BUREAU OF INDIAN STANDARDS

स्कूलों और कालेजों
के लिए
इंजीनियरी आरेखन रीति

**Engineering Drawing Practice
for
Schools & Colleges**

BUREAU OF INDIAN STANDARDS
MANAK BHAVAN, 9 BAHADUR SHAH ZAFAR MARG
NEW DELHI 110002

SP 46 : 2003

**FIRST PUBLISHED MARCH 1989
FIRST REVISION JULY 2003**

© BUREAU OF INDIAN STANDARDS

**ICS 01.100.01; 03.180
ISBN 81-7061-019-2**

Price: Rs. 1440.00

Typeset by M/s Paragon Enterprises, New Delhi

**Printed in India
at Printograph, 2966/40, Beadonpura, Karol Bagh, New Delhi-110005**

**And Published By
BUREAU OF INDIAN STANDARDS, 9 BAHADUR SHAH ZAFAR MARG, NEW DELHI 110002**

Drawing Sectional Committee, BP 24

<i>Organisation</i>	<i>Representing</i>
In personal capacity [<i>General Manager (Retd.), B.H.E.L., Tiruchirapalli</i>]	DR R. VASUDEVAN (<i>Chairman</i>)
Bharat Heavy Electricals Limited, Bhopal	SHRI V. W. BOKIL SHRI J. JAYASINGHRAJ (<i>Alternate I</i>) SHRI R. BHATIA (<i>Alternate II</i>)
Central Manufacturing Technology Institute, Bangalore	SHRI S. HANUMANTHA RAO SHRI S. K. MAHAJAN (<i>Alternate</i>)
Central Mechanical Engineering Research Institute, Durgapur	SHRI M. K. BANERJEE SHRI P. K. SHANGARI (<i>Alternate</i>)
Department of Atomic Energy, Mumbai	SHRI S. G. JOSHI SHRI N. R. SONAR (<i>Alternate</i>)
DGE & T, Ministry of Labour & Rehabilitation, New Delhi	SHRI S. I. SIDDIQUI SHRI N. SRINIVASAN (<i>Alternate</i>)
Directorate General of Supplies and Disposals, New Delhi	SHRI J. K. KHANNA SHRI R. KARUPPIAH (<i>Alternate</i>)
Engineers India Limited, New Delhi	SHRI G. R. RAJAGOPALAN
Fluid Power Society of India, Bangalore	SHRI T. S. VENKATESHA MURTHY
HMT Limited, Bangalore	SHRI K. B. RAMAKRISHNA SHRI S. L. NAHAR (<i>Alternate I</i>) SHRI N. K. SRINIVAS (<i>Alternate II</i>) SHRI M. D. GAUTAM (<i>Alternate III</i>)
Heavy Machine Building Plant, Ranchi	SHRI N. K. SINHA SHRI S. M. Q. ALAM (<i>Alternate I</i>) SHRI DINESH MOHAN (<i>Alternate II</i>)
Hindustan Aeronautics Limited, Bangalore	SHRI D. KRISHNA RAO SHRI C. GOVINDASAMY (<i>Alternate</i>)
Instrumentation Limited, Kota	SHRI N. S. CHAUDHARY SHRI J. S. SEHMI (<i>Alternate</i>)
Ministry of Defence, CQAE, Pune	SHRI A. V. KETKAR SHRI R. A. KULKARNI (<i>Alternate</i>)
Ministry of Defence, R & D E (Engrs), Pune	SHRI M. D. SAHU SHRI BALBIR SINGH (<i>Alternate</i>)
Motor Industries Co Limited, Bangalore	SHRI N. SRINIVASA MURTHY SHRI S. SAMPATH KUMAR (<i>Alternate</i>)
NGEF Limited, Bangalore	SHRI S. U. NARASIMHA MURTHY SHRI GOPINATH (<i>Alternate</i>)
Oil and Natural Gas Commission, Dehradun	SHRI ANJANI KUMAR SHRI R. N. GUPTA (<i>Alternate</i>)
Projects and Development India Limited, Dhanbad	SHRI R. PRASAD SINHA SHRI B. K. JHA (<i>Alternate</i>)
Research Design and Standards Organization, Lucknow	JOINT DIRECTOR WAGON-5 ASSISTANT DESIGN ENGINEER, WAGON-4 (<i>Alternate</i>)
Tata Engineering & Locomotive Co Limited, Jamshedpur	SHRI KANHAIYA SINGH SHRI S. UMAPATHY (<i>Alternate</i>)
The Institution of Engineers (I), Kolkata	SHRI W. L. DHAM
University Grants Commission, New Delhi	SHRI RAJENDRA PRAKASH
BIS Directorate General	SHRI P. D. PARASHAR, Director (SG) (BPD) [Representing Director General (<i>Ex-officio</i>)]

Member Secretary
SHRI S. D. DAYANAND
Deputy Director (BPD), BIS

Panel for Revision of SP 46

Organization

In personal capacity [*General Manager (Retd.), B.H.E.L.,
Tiruchirapalli*]

Central Manufacturing Technology Institute, Bangalore
Fluid Power Society of India, Bangalore
Hindustan Aeronautics Limited, Bangalore
HMT Limited, Bangalore
Motor Industries Co Limited, Bangalore
NGEF Limited, Bangalore

Representatives

DR R. VASUDEVAN (*Convener*)

SHRI S. HANUMANTHA RAO
SHRI T. S. VENKATESHA MURTHY
SHRI D. KRISHNA RAO
SHRI K. B. RAMAKRISHNA
SHRI N. SRINIVASA MURTHY
SHRI S. U. NARASIMHA MURTHY

FOREWORD

In all the three types of exchange like exchange of goods, exchange of services and exchange of information, technical drawings form an essential component.

Exchange of goods of technical nature in national and international trade nearly always need to be accompanied by service diagrams, or other technical drawings illustrating the components, their assembly and their use.

Exchange of services may involve, for example, consultancy work or the design of an assembly in one unit for construction in another. In such cases, the technical drawing is an important way of communicating instructions or advice.

In exchange of information, especially where different languages are involved, the technical drawings can clarify ambiguities or help to resolve problems in communicating by spoken or written word across languages barriers.

To achieve these objectives, IS 696 'Code of practice for general engineering drawings' was originally issued in 1955 and revised twice in 1960 and 1972. Since the publication of the said standard, considerable progress has been achieved in the field of standardization of engineering drawing by mutual agreement between various countries and has taken the shape of firm standard. The growing international cooperation, introduction of foreign technology or export of technology has necessitated to develop internationally unified method and symbols for indicating in engineering drawing.

To meet the above necessity, the contents of IS 696 : 1972 'Code of practice for general engineering drawings (*second revision*)' have been harmonized with the relevant subject matter of ISO technical drawings and published a series of standards on technical drawing. IS 696 was so long being used by the students of technical institutions as a guide in engineering drawing. The technical committee responsible felt the need to bring out a special publication containing relevant information in the field of drawing standard in one document to meet the requirements of the students. Accordingly, a special publication SP 46 : 1988 'Engineering drawing practice for schools and colleges' was brought out in the year 1988. This publication also includes geometrical tolerancing, guide for selection of fits in addition to the general principles and convention of engineering drawing to make the publication more informative. Since then, lot of changes have taken place in the International and Indian Standards. This revised edition incorporates all the changes applicable to Engineering drawings till the beginning of the year 2001.

This publication is not intended to be a replacement for the complete standards on technical drawings and any parts omitted from this publication should not be considered as less important to the engineering profession than those included.

It is expected that educational institutions will have complete set of Indian Standards accessible in technical drawing classes.

Where there are no corresponding Indian Standards for the International Standards referred on this Special Publication, reference to the relevant International Standards may be made.

NOTES ON THE USE OF THIS PUBLICATION

1. Except for the drawings shown in Annex A, the figures used in the document are not intended to be examples of fully dimensioned working drawings. They are drawn to show the point explained in the text.
2. Examples of both **FIRST ANGLE** and **THIRD ANGLE** methods of projections are given (*see Projections*). As a basic requirement use of **FIRST ANGLE METHOD** only is to be followed for drawings prepared after 31 December 1991.
3. Values of dimensions and tolerances are typical examples only.
4. In view of extensive use of CADD and to unify the practices followed by various engineering disciplines, namely, civil, mechanical, electrical, electronics, etc, the contents of latest versions of International Standards have been incorporated in this version.

CONTENTS

Page

Foreword	v	
Notes on the Use of this Publication	vi	
Section 1	Sizes and Layout of Drawing Sheets	1
Section 2	Item References on Drawings and Item Lists	5
Section 3	Planning of Assembly Drawings	7
Section 4	Folding of Drawing Prints	9
Section 5	Scales	12
Section 6	Lines	13
Section 7	Lettering	52
Section 8A	Projection Methods — Synopsis	57
Section 8B	Projection Methods — Orthographic Representations	59
Section 8C	Projection Methods — Axonometric Representations	65
Section 8D	Projection Methods — Central Projection	70
Section 9	Technical Drawings — Simplified Representation of Pipelines — General Rules, Orthogonal Representation and Isometric Projection	86
Section 10	Sections and Other Conventions	98
Section 11A	Conventional Representation of Screw Threads and Threaded Parts — General Conventions	107
Section 11B	Conventional Representation of Screw Threads and Threaded Parts — Simplified Representation	111
Section 11C	Conventional Representation of Springs — Simplified Representation	113
Section 11D	Conventional Representation of Gears on Technical Drawings	118
Section 12	General Principles of Dimensioning on Technical Drawings	122
Section 13	Indication of Linear and Angular Tolerances on Technical Drawings	134
Section 14	Dimensioning of Cones	137
Section 15	Indication of Surface Texture in Technical Product Documentation	139
Section 16	Simplified Representation of the Assembly of Parts with Fasteners	149
Section 17	Simplified Representation of Bars and Profile Sections	152
Section 18	Welded, Brazed and Soldered Joints — Symbolic Representation on Drawings	156
Section 19	Examples of Indication and Interpretation of Geometrical Tolerancing Symbols and Characteristics	179
Section 20	Abbreviations	181
Annex A	Typical Examples	183
Annex B	Systems of Limits and Fits	185
Annex C	Guide for Selection of Fits	189
Annex D	General Tolerances for Linear and Angular Dimensions	195
Annex E	List of Referred and Other Relevant Indian Standards and International Standards	197
Alphabetical Index		201

SECTION 1 SIZES AND LAYOUT OF DRAWING SHEETS

[Based on IS 10711 : 1983/ISO 5457 : 1980 and IS 11665 : 1985/ISO 7200 : 1984]

1.1 Scope

This section specifies sizes of blank and pre-printed drawing sheets for use with all technical drawings in any field of engineering.

1.2 Basic Principles

The basic principles involved in arriving at the sizes are:

- a) $x : y = 1 : \sqrt{2}$
- b) $xy = 1$

where x and y are the sides and having a surface area of 1m^2 so that $x = 0.841\text{ m}$ and $y = 1.189\text{ m}$.

1.2.1 Two series of successive format sizes are obtained by halving along the length or doubling along the width. The areas of the two sizes are in the ratio 1 : 2 (see Fig. 1.1)

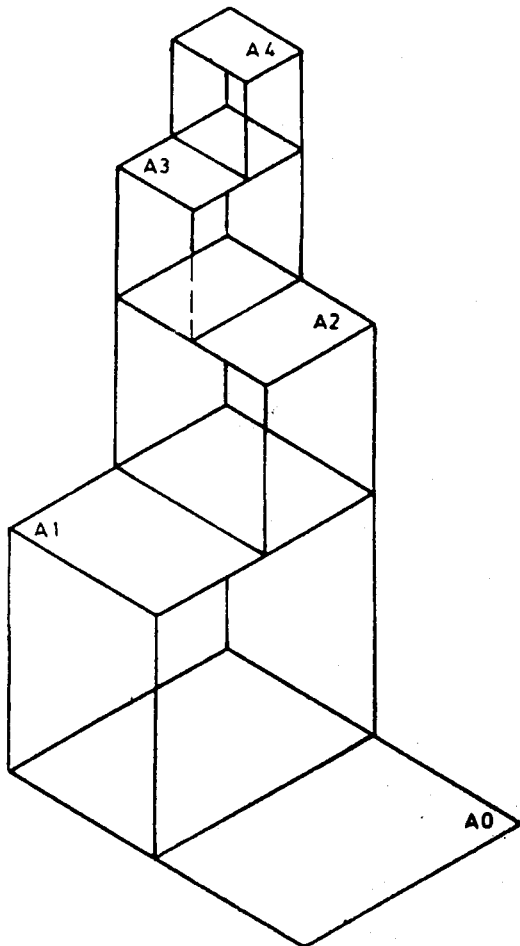


FIG. 1.1

1.2.2 The forms are similar to one another and hence the equation $x : y = 1 : \sqrt{2}$ is obtained for the two sides x and y of a format (see Fig. 1.2), consequently the ratio between both sides is the same as that of the sides of a square to its diagonal (see Fig. 1.3).

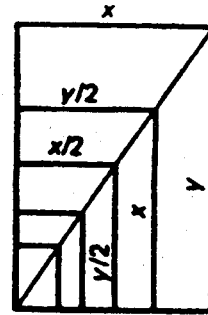


FIG. 1.2 SIMILARITY OF FORMATS

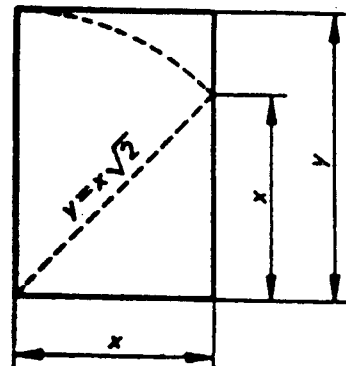


FIG. 1.3 RELATIONSHIP BETWEEN TWO SIDES

1.3 Designation of Sizes

1.3.1 Sizes Series ISO-A (First Choice)

The preferred sizes of the trimmed sheets as selected from the main ISO-A Series are given in Table 1.1.

Table 1.1 Sizes Series ISO-A
(Clauses 1.3.1 and 1.4)

Designation	Dimensions, mm
A 0	841 × 1 189
A 1	594 × 841
A 2	420 × 594
A 3	297 × 420
A 4	210 × 297

1.3.2 Special Elongated Sizes (Second Choice)

When a sheet of greater length is needed, one of the sizes in Table 1.2 should be used. These sizes are obtained by extending the shorter sides of a format of the ISO-A series to lengths that are multiples of the shorter sides of the chosen basic format.

Table 1.2 Special Elongated Sizes
(Clauses 1.3.2 and 1.4)

Designation	Dimensions, mm
A 3 × 3	420 × 891
A 3 × 4	420 × 1 189
A 4 × 3	297 × 630
A 4 × 4	297 × 841
A 4 × 5	297 × 1 051

1.3.3 Exceptional Elongated Sizes (Third Choice)

When a very large or extra elongated sheet is essential, one of the size in Table 1.3 should be used. These sizes are obtained by extending the shorter sides of a format of the ISO-A series to lengths that are multiples of the shorter sides of the chosen basic format.

Table 1.3 Exceptional Elongated Sizes
(Clauses 1.3.3 and 1.4)

Designation	Dimensions, mm
A 0 × 2 ¹⁾	1 189 × 1 682
A 0 × 3	1 189 × 2 523 ²⁾
A 1 × 3	841 × 1 783
A 1 × 4	841 × 2 378 ²⁾
A 2 × 3	594 × 1 261
A 2 × 4	594 × 1 682
A 2 × 5	594 × 2 102
A 3 × 5	420 × 1 486
A 3 × 6	420 × 1 783
A 3 × 7	420 × 2 080
A 4 × 6	297 × 1 261
A 4 × 7	297 × 1 471
A 4 × 8	297 × 1 682
A 4 × 9	297 × 1 892

¹⁾ This size is equal to 2 A 0 of the ISO-A series.

²⁾ For practical reasons, the use of these sizes is not advisable.

1.4 Selection of Sizes

The original drawing should be made on the smallest sheet permitting the necessary clarity and resolution. The choice of sizes of the original drawing and its reproduction shall be made from the series shown in Tables 1.1, 1.2 and 1.3 in that order. Drawing sheets may be used with their longer sides positioned either horizontally (see Fig. 1.4) or vertically (see Fig. 1.5). The general features of a drawing sheet is as shown in Fig. 1.6.

1.5 Title Block

1.5.1 Position

1.5.1.1 The position of the title block should be within the drawing space (see Fig. 1.6) such that the portion

of the title block containing the identification of the drawing (registration number, title, origin, etc) is situated in the bottom right-hand corner of the drawing space, both for sheets positioned horizontally (Type X) (see Fig. 1.4) or vertically (Type Y) (see Fig. 1.5). The direction of the viewing of the title block should correspond, in general, with that of the drawing.

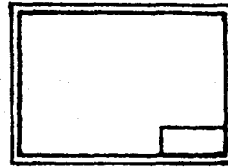


FIG. 1.4 SHEET TYPE X—HORIZONTAL

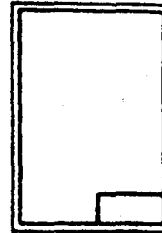


FIG. 1.5 SHEET TYPE Y—VERTICAL

1.5.1.2 Title block should preferably consist of one or more adjoining rectangles. These may be sub-divided into boxes for the insertion of specific information (see Fig. 1.7, 1.8 and 1.9).

1.6 Borders and Frames

Borders enclosed by the edges of the trimmed sheet and the frame limiting the drawing space shall be provided with all sizes. It is recommended that these borders have the minimum width of 20 mm for sizes A0 and A1, and a minimum width of 10 mm for size A2, A3 and A4 (see Fig. 1.6).

1.7 Centring Marks

Four centring marks shall be provided on all drawings in order to facilitate the positioning of the drawing when reproduced or microfilmed.

1.8 Orientation Marks

Two orientation marks may be provided to indicate the orientation of the drawing sheet on the drawing board.

These marks consist of arrows (see Fig. 1.10) and should be placed across the frame, one at a shorter side and one at a longer side, coinciding with the centring marks on those sides, so that one of the orientation marks always points to the draughtsman.

1.9 Metric Reference Graduation

It is recommended to provide on all drawings a figureless metric reference graduation with a minimum length of 100 mm and divided into 10 mm intervals (see Fig. 1.11).

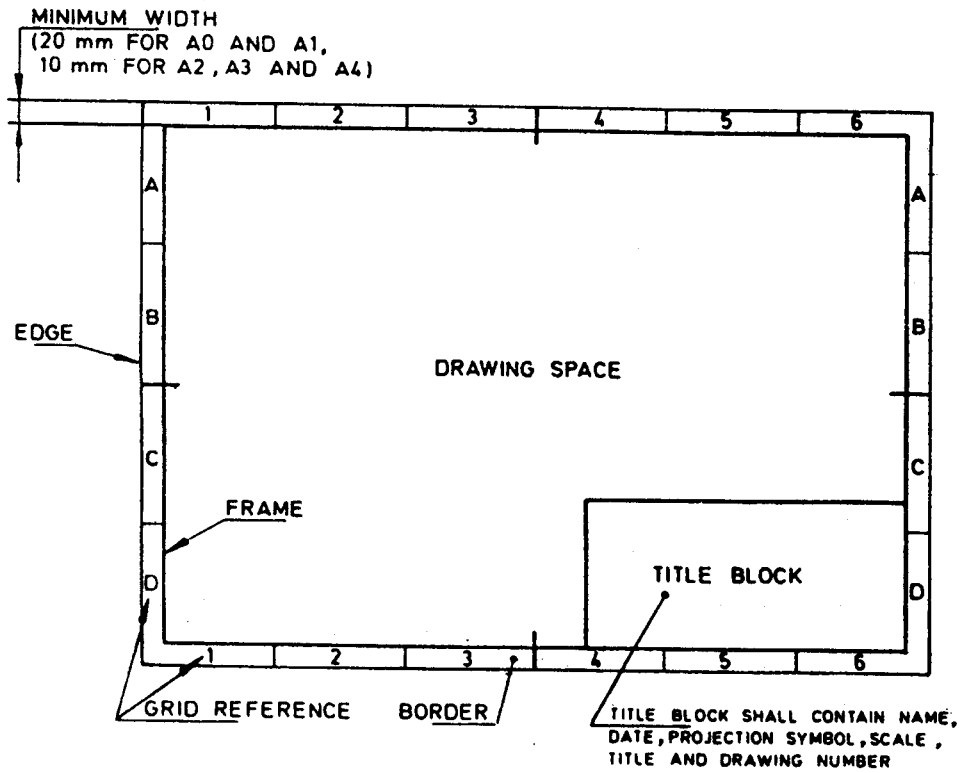


FIG. 1.6

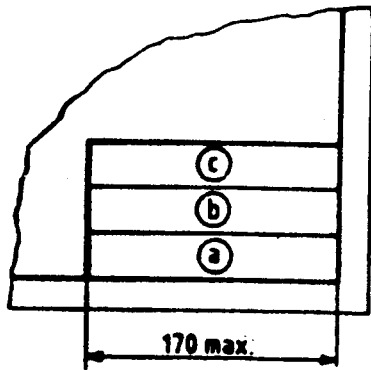


FIG. 1.7

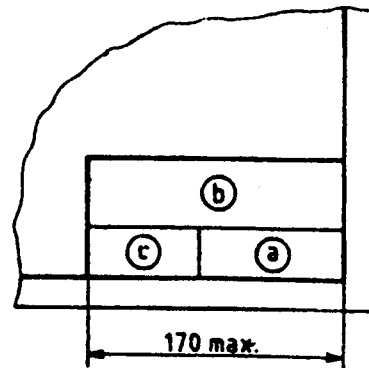


FIG. 1.9

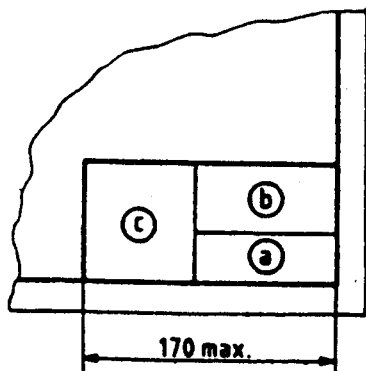


FIG. 1.8

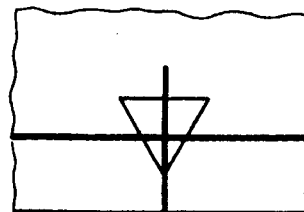


FIG. 1.10 ORIENTATION MARKS

The metric reference graduation shall preferably be disposed symmetrically about a centring mark, near the frame in the border, with a maximum width of 5 mm and be executed with continuous stroke of 0.5 mm minimum thickness.

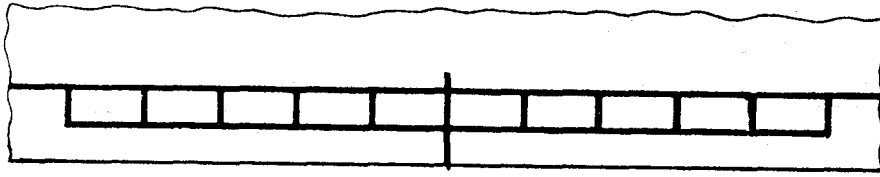


FIG. 1.11 METRIC REFERENCE GRADUATION

The metric reference graduation is to be repeated on each section of a drawing which is intended to be microfilmed in more than one section.

1.10 Grid References

1.10.1 The provision of grid reference system is recommended for all sizes, in order to permit easy location on the drawing of details, additions, modifications, etc. The number of divisions should be divisible by two and be chosen in relation to the complexity of the drawing. It is recommended that the length of any side of the rectangles comprising the grid shall not be less than 25 mm and not more than 75 mm.

1.10.2 The rectangles of the grid should be referred by means of capital letters along one edge and numerals along the other edge. The numbering direction may

start at the sheet corner opposite to the title block and be repeated on the opposite sides.

1.11 Multiple Sheet Drawings

Multiple sheet drawings marked with the same registration or identification number should be indicated by means of a sequential sheet number. In addition, the total number of sheet should be shown on sheet 1, for example:

$$\text{Sheet No.} = n/p$$

where

n is the sheet number, and

p is the total number of sheets.

An abbreviated title block, containing only the identification zone, may be used for all sheets after the first sheet.

SECTION 2 ITEM REFERENCES ON DRAWINGS AND ITEM LISTS

[Based on IS 10712 : 1983/ISO 6433 : 1981 and IS 11666 : 1985/ISO 7573 : 1983]

2.1 Scope

This section gives guidance and recommendations on establishment of item reference and item list for use with technical drawings.

2.2 Item References

The item references should be assigned in sequential order to each component part shown in an assembly and/or each detailed item on the drawing. Further identical parts shown in the same assembly should have the same item reference. All item references shall be shown in an item list (see Fig. 2.1 and Table 2.1).

Table 2.1 Item List
(Clause 2.2)

Item	Quantity	Description	Reference	Material
1	1	Base		
2	1	Bottom housing		
3	1	Top housing		
4	1	Bearing		
5	1	Filling plug		
6	2	T-bolt		
7	2	Hex nut		
8	4	Washer		
9	2	T-bolt		
10	2	Castle nut		
11	2	Split pin		
12	1	Drain plug		

2.3 Presentation

2.3.1 Item references should generally be composed of Arabic numerals only. They may, however, be augmented by capital letters when necessary.

2.3.2 All references on the same drawing shall be of the same type and height of lettering. They shall be clearly distinguishable from all other indications. This can be achieved, for example, by:

- a) using characters of a larger height, for example, twice the height as used for dimensioning and similar indications;
- b) encircling the characters of each item reference, in that case all such circles shall have the same diameter and to be drawn with continuous narrow line (see Fig. 2.2).
- c) combining methods (a) and (b).

2.3.3 Item references shall be placed outside the general outlines of the items concerned.

2.3.4 Each item reference should be connected to its associated item by a leader line (see Fig. 2.2, 2.3 and 2.4).

2.3.5 Leader lines shall not intersect. They should be kept as short as practicable and generally should be drawn at an angle to the item reference. In case of encircled item references, the leader line shall be directed towards the centre of the circle.

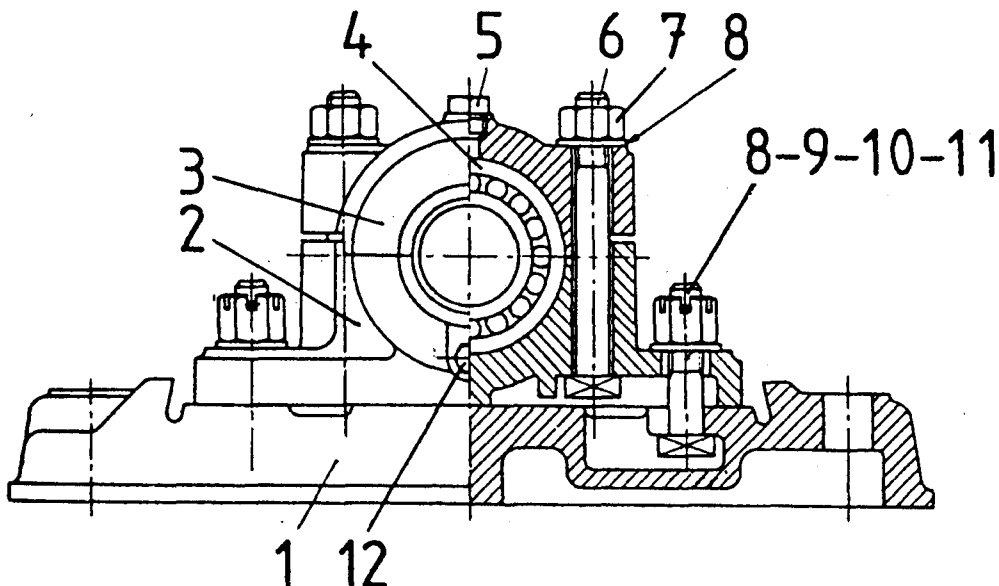


FIG. 2.1

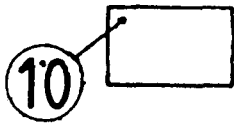


FIG. 2.2



FIG. 2.3



FIG. 2.4

2.3.6 Item references of related items may be shown against the same leader line (see Fig. 2.1, Items 8, 9, 10 and 11). These item references may be separated from each other by a short—when written horizontally.

2.3.7 Item references of identical items need only be shown once, provided there is no risk of ambiguity.

2.4 Item List

2.4.1 Item lists are complete lists of the items constituting an assembly (or a sub-assembly), or of detailed parts, presented on a technical drawing. It is not necessary for all these items to be detailed on an end-product drawing. The association between the items on an item-list and their representation on the relevant drawing (or on other drawings) is given by the item references.

2.4.2 The item lists may be included on the drawing itself or be a separate document.

When the item list is included in the drawing, the sequence shall be from bottom to top, with headings of the column immediately underneath with separate item lists, the sequence shall be from top to bottom with headings at the top.

2.4.3 When included on the drawing, the position of the item list should be such as to be read in the viewing direction of the drawing. The list may be in conjunction with the title block. Its outlines may be drawn with continuous wide lines.

2.4.4 Where the item list is shown on a separate document, this shall be identified by the same number as that of the parent drawing.

2.4.5 However, to distinguish this identification from that of the parent drawing, it is recommended that the item list number be preceded by the prefix item list (or a similar term in the language used on the documents).

2.4.6 Layout

It is recommended that the item list be arranged in columns by means of continuous wide or narrow lines to allow information to be entered under the following headings (the sequence of these is optional):

- a) item,
- b) description,
- c) quantity,
- d) reference, and
- e) material.

NOTE — If necessary, more columns can be added to cover specific requirements.

SECTION 3 PLANNING OF ASSEMBLY DRAWINGS

[Based on DIN 199-2 : 1977]

3.1 Scope

This section covers the requirements of planning of assembly drawings.

3.2 Where a number of drawings are required to detail a complete design, an assembly drawing is necessary. Such a drawing will show the design to a convenient scale, and the drawing or part numbers which are the constituents of the particular assembly are listed in

a tabular form as shown in Fig. 2.1 and Table 2.1

3.3 A method, applicable to general engineering drawings and also structural drawings is to include on each individual drawing sheet of a series of drawings, a small key plan or elevation or both, conveniently placed near the title block, indicating part of the whole work in continuous wide lines to which the particular drawing sheet refers (see Fig. 3.1).

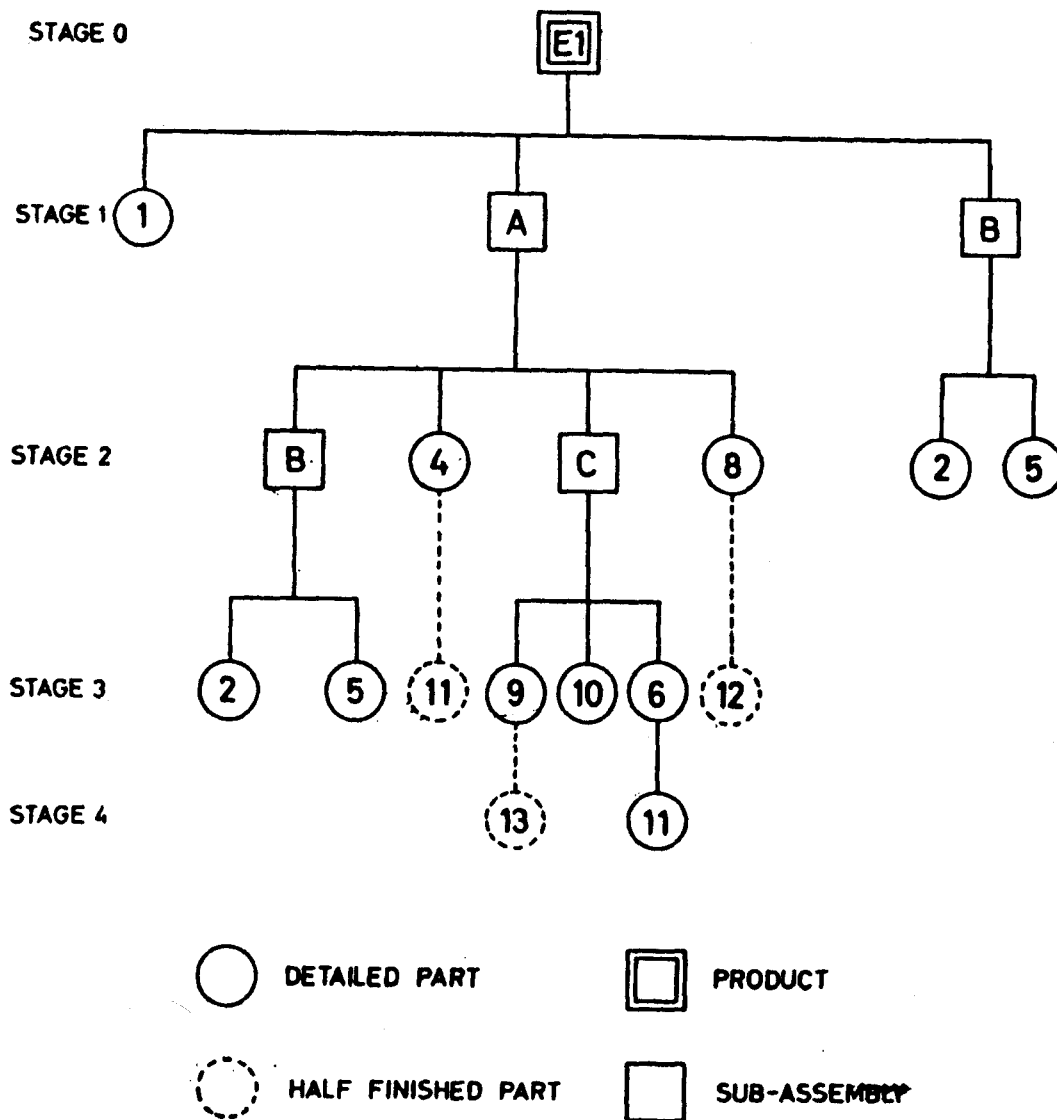
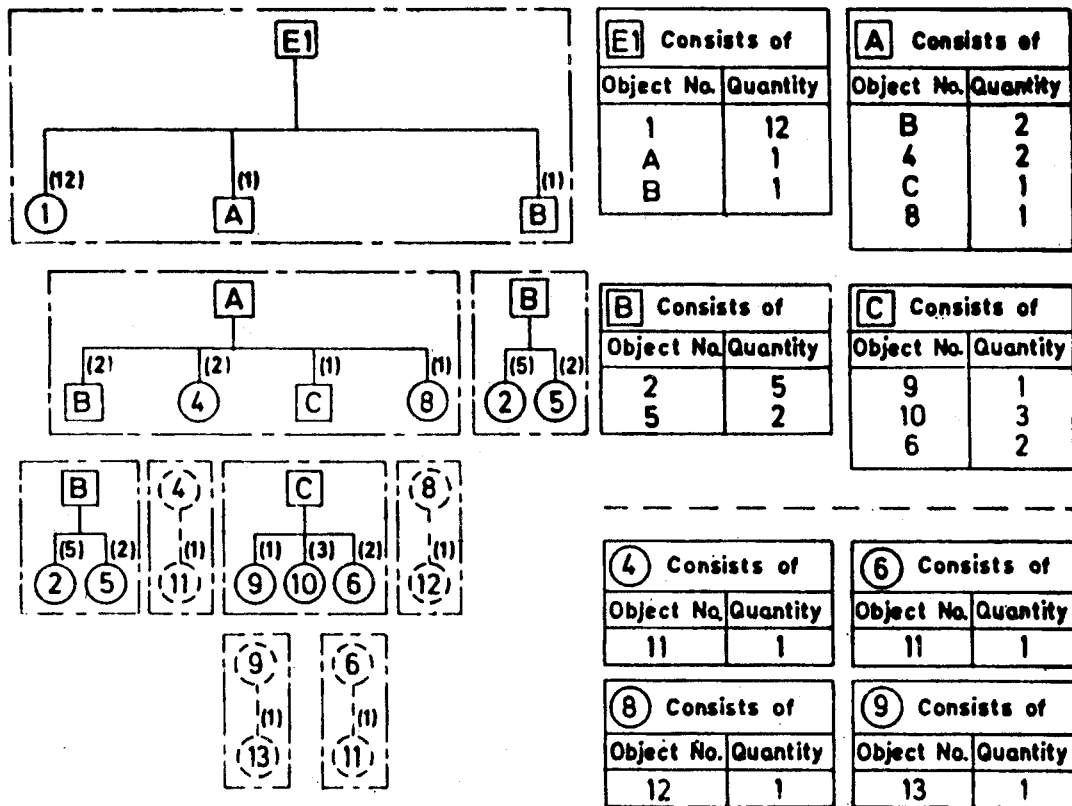


FIG. 3.1

3.4 The general assembly drawing may be broken into further sub-assemblies and parts, determined mainly by production requirements. A typical chart showing the breakdown of such assembly drawing is shown in Fig. 3.2.

3.5 In general, the detailed view shown in any assembly drawing should have the same orientation as that shown in the main assembly view.



EXPLANATION OF SYMBOLS

- GROUP PRODUCT
- COMPOSITE PART
- SEMI-FINISHED PRODUCT
- () INDICATION OF QUANTITY IN THE PARTS LIST

FIG. 3.2

SECTION 4 FOLDING OF DRAWING PRINTS

[Based on IS 11664 : 1986]

4.1 Scope

This section covers two methods of folding of drawing prints.

4.1.1 The first method is intended for drawing prints to be filed or bound, while the second method is intended for prints to be kept individually in filing cabinet.

4.2 Basic Principles

The basic principles in each of the above methods are to ensure that:

- a) all large prints of sizes higher than A4 are folded to A4 sizes;
- b) the title blocks of all the folded prints appear in topmost position; and
- c) the bottom right corner shall be outermost visible section and shall have a width not less than 190 mm.

4.3 Depending on the method of folding adopted, suitable folding marks are to be introduced in the tracing sheets as guide.

4.4 Method of Folding of Drawing Prints

The methods recommended for folding are indicated in Fig. 4.1 and 4.2

SHEET DESIGNATION	FOLDING DIAGRAM	LENGTHWISE FOLDING	CROSSWISE FOLDING
<p>A0 841 x 1189</p>			
<p>A1 594 x 841</p>			
<p>A2 420 x 594</p>			
<p>A3 297 x 420</p>			<p>—</p>

All dimensions in millimetres.

FIG. 4.1 FOLDING OF PRINTS FOR FILING OR BINDING

SHEET DESIGNATION	FOLDING DIAGRAM	LENGTHWISE FOLDING	CROSSWISE FOLDING
<p>A0 841 x 1189</p>			
<p>A1 594 x 841</p>			
<p>A2 420 x 594</p>			
<p>A3 297 x 420</p>			<p>—</p>

All dimensions in millimetres.

FIG. 4.2 FOLDING OF PRINTS FOR STORING IN FILING CABINET

SECTION 5 SCALES

[Based on IS 10713 : 1983/ISO 5455 : 1979]

5.1 Scope

This section specifies recommended scales and their designation for use on all technical drawings in any field of engineering.

5.2 Definitions

5.2.1 Scale

Ratio of the linear dimension of an element of an object as represented in the original drawing to the real linear dimension of the same element of the object itself.

NOTE — The scale of a print may be different from that of the original drawing.

5.2.2 Full Size

A scale with the ratio 1 : 1.

5.2.3 Enlargement Scale

A scale where the ratio is larger than 1 : 1. It is said to be larger as its ratio increases.

5.2.4 Reduction Scale

A scale where ratio is smaller than 1 : 1. It is said to be smaller as its ratio decreases.

5.3 Designation

The complete designation of a scale shall consist of the word 'SCALE' (or its equivalent in the language used on the drawing) followed by the indication of its ratio, as follows:

- SCALE 1 : 1 for full size;
- SCALE X : 1 for enlargement scales;
- SCALE 1 : X for reduction scales.

If there is no likelihood of misunderstanding, the word SCALE may be omitted.

5.4 Scales for Use on Technical Drawings

<i>Category</i>	<i>Recommended Scales</i>			
Enlargement Scales	50 : 1 5 : 1	20 : 1 2 : 1	10 : 1	
Full size			1 : 1	
Reduction Scales	}	1 : 2	1 : 5	1 : 10
		1 : 20	1 : 50	1 : 100
		1 : 200	1 : 500	1 : 1000
		1 : 2000	1 : 5000	1 : 10000

NOTE — In exceptional cases where for functional reasons the recommended scales cannot be applied, intermediate scales may be chosen.

5.4.1 The scale to be chosen for a drawing will depend upon the complexity of the object to be depicted and the purpose of the representation.

5.4.2 In all cases, the selected scale shall be large enough to permit easy and clear interpretation of the information depicted.

5.4.3 Details that are too small for complete dimensioning in the main representation shall be shown adjacent to the main representation in a separate detail view (or section) which is drawn to a large scale.

5.4.4 It is recommended that, for information a full size view be added to the large scale representation of a small object.

In this case the full size view may be simplified by showing the outlines of the object only.

SECTION 6 LINES

[Based on IS 10714 (Part 20) : 2001/ISO 128-20 : 1996, IS 10714 (Part 21) : 2001/ISO 128-21 : 1997, ISO 128-22 : 1999, ISO 128-23 : 1999 and ISO 128-24 : 1999]

6.1 Scope

This section establishes types of lines, their designations and configurations and general rules for draughting of lines used in

- Technical drawings (for example, Diagrams, Plans and Maps)
- Lines by CAD systems
- Leader lines, reference lines and their components
- Lines used in construction documentation
- Lines used in mechanical engineering drawings

6.2 Definitions

6.2.1 Line

Geometrical object, the length of which is more than half of the line width and which connects an origin with an end in any way, for example, straight, curved, without or with interruptions.

NOTES

- 1 The origin and the end may coincide with one another, for example, in the case of a line forming a circle.
- 2 A line, the length of which is less than or equal to half of the line width, is called a dot.
- 3 A test should be made in order to check the appearance of drawings intended to be microcopied or transferred by fax.

6.2.2 Line Element

Single part of a non-continuous line, for example, dots, dashes, which vary in length, and gaps.

6.2.3 Line Segment

Group of two or more different line elements which form a non-continuous line, for example, long dash/gap/dot/ gap/dot/gap.

6.3 Types of Lines

6.3.1 Basic Types (see Table 6.1)

6.3.2 Variations of the Basic Types of Lines

Possible variations of the basic types of lines in accordance with Table 6.1 are given in Table 6.2.

6.3.3 Combinations of Lines with the Same Length

6.3.3.1 Arrangement of two or more lines parallel to each other

For examples see Fig. 6.1.

6.3.3.2 Arrangement of two different types of lines

- a) With different line widths superimposed.
See Fig. 6.2 (a) and (b) for examples; [Fig. 6.2 (a): a continuous and a dotted line; Fig. 6.2 (b): a continuous and a dashed space line].
- b) Arranged next to each other.
See Fig. 6.3 for an example (two continuous lines either side of two dashed spaced lines).

6.3.3.3 Arrangement of two continuous lines parallel to each other with regularly recurring connecting elements between them

See Fig. 6.4 (a) and (b) for examples [Fig. 6.4 (a): blackened circular elements; Fig. 6.4 (b): blackened trapezoidal elements].

6.3.3.4 Arrangement of regularly recurring geometric pictorial elements in association with continuous lines

- a) Without interruption of a continuous line.
See Fig. 6.5 for examples.
- b) With interruption of a continuous line.
See Fig. 6.6 for examples.

6.4 Line Dimensions

6.4.1 Line Width

The width, d , of all types of lines shall be one of the following depending on the type and size of drawing. This series is based on a common ratio $1 : \sqrt{2}$ ($\approx 1 : 1.4$):

0.13 mm; 0.18 mm; 0.25 mm; 0.35 mm; 0.5 mm;
0.7 mm; 1 mm; 1.4 mm; 2 mm

The widths of extra wide, wide and narrow lines are in the ratio 4 : 2 : 1.

The line width of any one line shall be constant throughout the whole line.

6.4.2 Deviation in Line Width

Line widths may deviate from those specified in 6.4.1 providing that it is possible to differentiate unambiguously between two adjacent lines with different widths. If drawing equipment which produces constant line width is used, the deviation in

Table 6.1 Basic Types of Lines
(Clause 6.3.1)


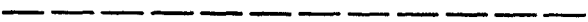












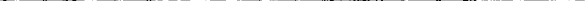

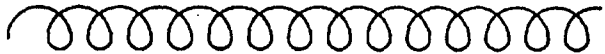

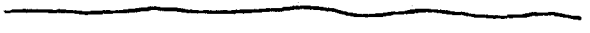
No.	Representation	Description
01		continuous line
02		dashed line
03		dashed spaced line
04		long dashed dotted line
05		long dashed double-dotted line
06		long dashed triplicate-dotted line
07		dotted line
08		long dashed short dashed line
09		long dashed double-short dashed line
10		dashed dotted line
11		double-dashed dotted line
12		dashed double-dotted line
13		double-dashed double-dotted line
14		dashed triplicate-dotted line
15		double-dashed triplicate-dotted line

Table 6.2 Variations of the Basic Types of Lines
(Clause 6.3.2)

Representation	Description
	uniform wavy continuous line
	uniform spiral continuous line
	uniform zigzag continuous line
	freehand continuous line

NOTE — Table contains only variations of the basic type of line No. 01. Variations of the basic types Nos. 02 to 15 are possible and are presented in the same way.

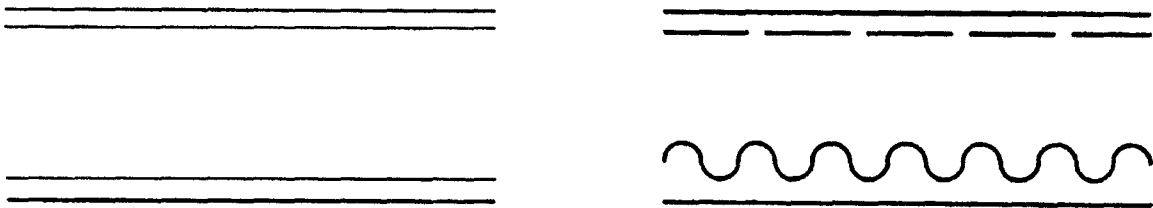


FIG. 6.1



FIG. 6.2



FIG. 6.3



FIG. 6.4

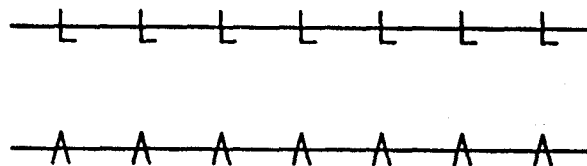


FIG. 6.5

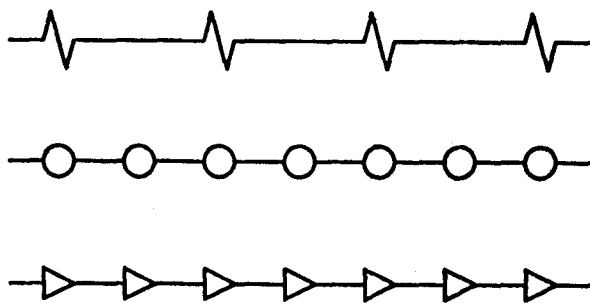


FIG. 6.6

line width between two such lines shall not be greater than $\pm 0.1 d$.

6.4.3 Configuration of Lines

For the preparation of drawings by hand, the lengths of the line elements should conform to those of Table 6.3.

Table 6.3 Configuration of Lines
(Clauses 6.4.3 and 6.8.6)

Line Element	Line Type No.	Length
Dots	04 to 07 and 10 to 15	$\leq 0.5 d$
Gaps	02 and 04 to 15	$3 d$
Short dashes	08 and 09	$6 d$
Dashes	02, 03 and 10 to 15	$12 d$
Long dashes	04 to 06, 08 and 09	$24 d$
Spaces	03	$18 d$

NOTE— The lengths shown in this table are valid for line elements with semi-circular and squared ends. In the case of line elements with semi-circular ends, the length of the line element corresponds to the distance covered by a technical pen (with a tubular tip and using India ink) from the origin up to the end of the line element. The total length of such a line element is the sum of the length shown in the table plus d .

Formulae for the calculation of some of the basic types of line and line elements are given in IS 10714 (Part 21). The formulae are intended to facilitate the preparation of drawings using Computer-Aided Design (CAD) systems.

6.5 Draughting of Lines

6.5.1 Spacing

The minimum space between parallel lines should not be less than 0.7 mm, unless rules to the contrary are stated in other Indian Standards.

NOTE — In certain cases when computer-aided drawing techniques are used, the spacing of lines on the drawing does not represent the actual spacing, for example, for the representation

of screw threads. This fact has to be considered when data sets are established, for example, for the operation of machine tools.

6.5.2 Junctions

6.5.2.1 Types

The basic types of lines, Nos. 02 to 06 and Nos. 08 to 15 should preferably meet at a dash (see Fig. 6.7 to 6.12).

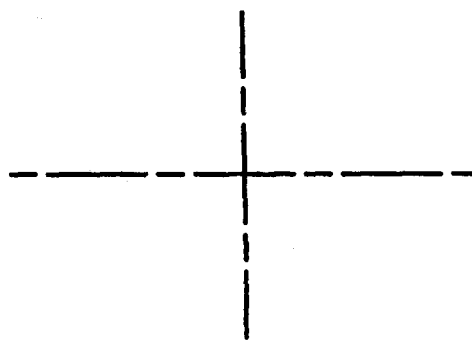


FIG. 6.7

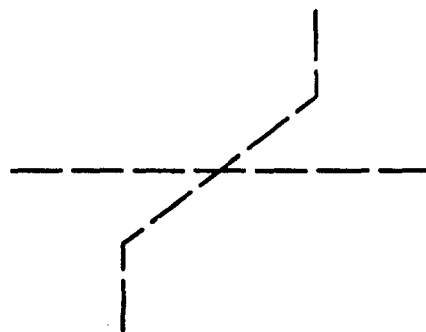


FIG. 6.8

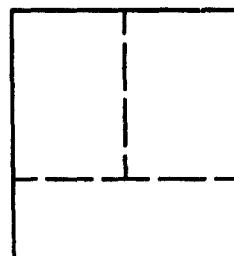


FIG. 6.9

Lines of basic type No. 07 should preferably meet at a dot (*see* Fig. 6.13).

6.5.2.2 Representation

The requirement of 6.5.2.1 shall be fulfilled by starting the lines at the junction (*see* Fig. 6.14) or by using a complete, or partial, cross formed by dashes (*see* Fig. 6.15 and 6.16).

6.5.3 Location of a Second Line

Two different ways of draughting two parallel lines are shown in Fig. 6.17 (a) and (b). The preferred version

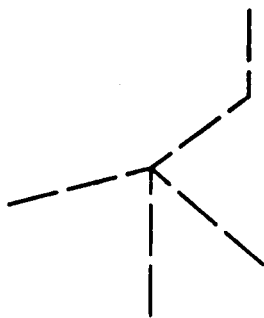


FIG. 6.10

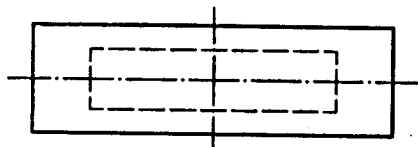


FIG. 6.11

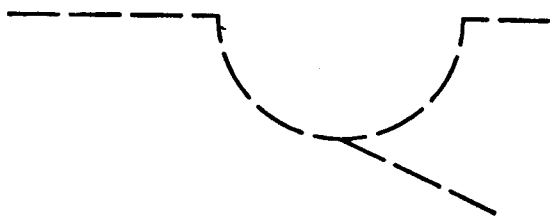


FIG. 6.12

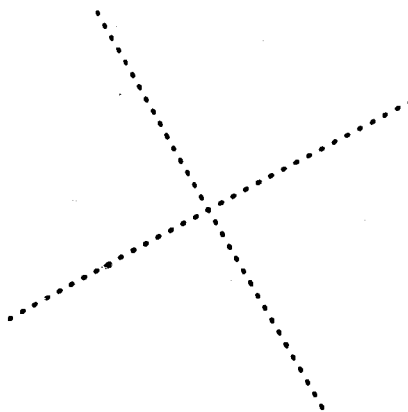


FIG. 6.13

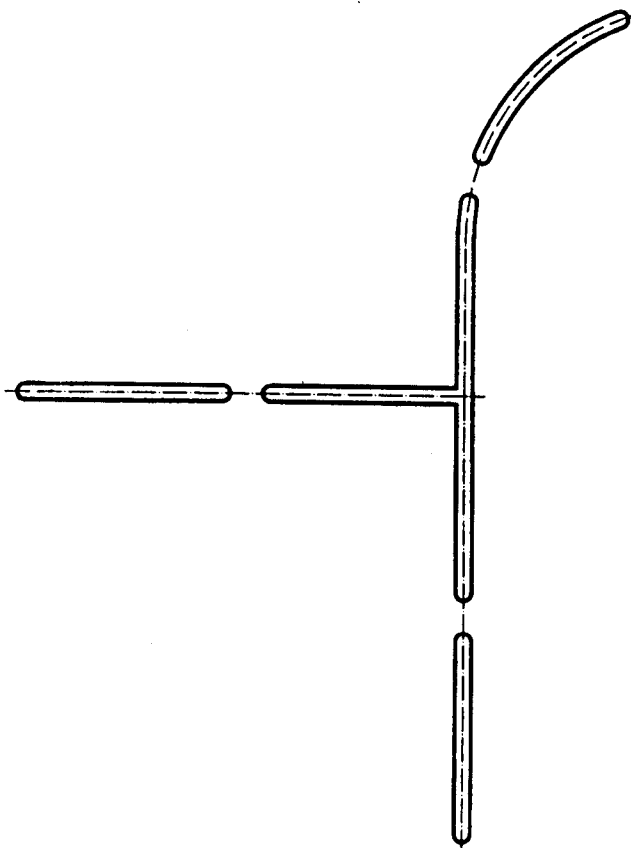


FIG. 6.14

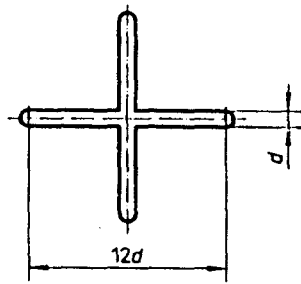


FIG. 6.15

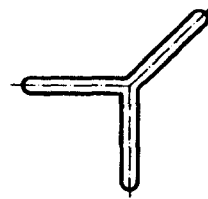
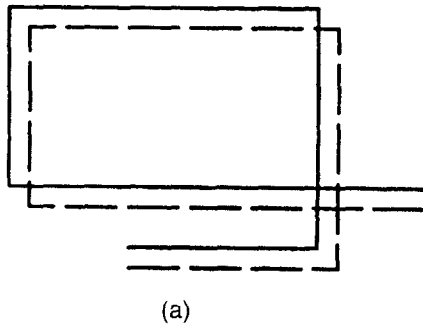
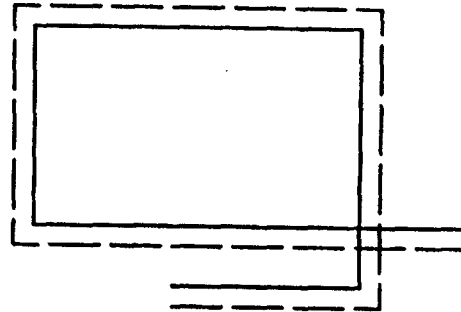


FIG. 6.16



(a)



(b)

FIG. 6.17

is shown in Fig. 6.17 (a) (the second line is drawn below or to the right of the first line).

- d) The line width in accordance with 6.4.1; and
- e) The colour (if applicable).

6.6 Colours

Lines shall be drawn in black or white depending on the colour of the background. Other standardized colours may also be used for drawing standardized lines. In such case, the meaning of the colours shall be explained.

6.7 Designation

The designation of the basic types of lines shall comprise the following elements in the order given:

- a) "Line";
- b) Reference to this part of IS 10714;
- c) The number of the basic type in accordance with Table 6.1;

Examples

Designation of a line of type No. 03 (03), line width 0.25 mm (0.25):

Line IS 10714-20 —03 × 0.25

Designation of a line of type No. 05 (05), line width 0.13 mm (0.13) and white in colour:

Line IS 10714-20 —05 × 0.13 / white

6.8 Calculation of Line Elements

6.8.1 Line Type No. 02 (Dashed Line)

See Fig. 6.18 for the configuration of this type of line.

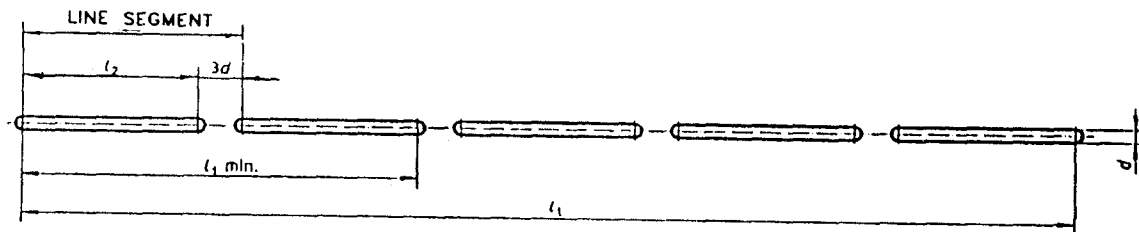


FIG. 6.18

Example

See Fig. 6.19

Formulae:

a) Length of the line: $l_1 = l_0$

b) Number of line segments within the line:

$$n = \frac{l_1 - 12d}{15d} \text{ (rounded)}$$

c) Length of the dashes:

$$l_2 = \frac{l_1 - 3dn}{n + 1}$$

d) Minimum length of this line:

$$l_{1 \text{ min}} = l_{0 \text{ min}} = 27d$$

(2 dashes 12 d , 1 gap 3 d)

If dashed lines with a length less than $l_1 = 27d$, have to be drawn, a larger scale from IS 10713 shall be used (that is, the elements are drawn at a larger scale).

This line may be drawn with a constant length of dashes (12 d). In this case one end of the line may be a shorter or longer dash.

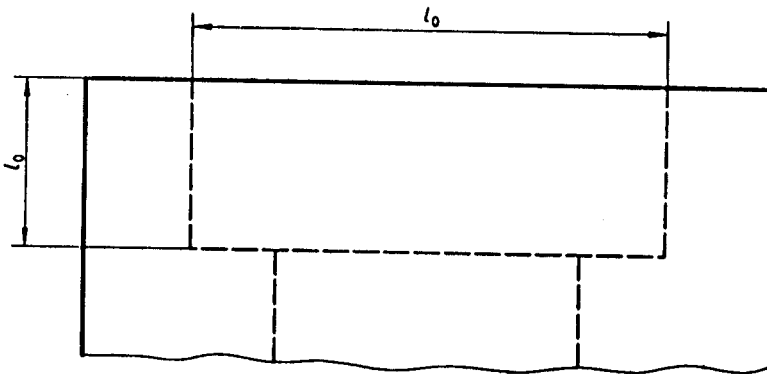


FIG. 6.19

Example

$l_1 = 125$ $d = 0.35$

$$n = \frac{125 - 4.2}{5.25} = 23.01 \hat{=} 23$$

$$l_2 = \frac{125 - 24.15}{24} = 4.202$$

Interpretation of the result—A dashed line, of length 125 mm and line width 0.35 mm; consists of 23 line segments of length 5.252 mm (4.202 mm + 1.050 mm) and one dash of length 4.202 mm.

6.8.2 Line Type No. 04 (Long Dashed Dotted Line)

See Fig. 6.20 for the configuration of this type of line.

Example

See Fig. 6.21.

Formulae:

a) Length of the line:

$$l_1 = l_0 + 24d$$

(line extended over the outlines at both sides)

b) Number of line segments within the line:

$$n = \frac{l_1 - 24d}{30.5d} \text{ (rounded)}$$

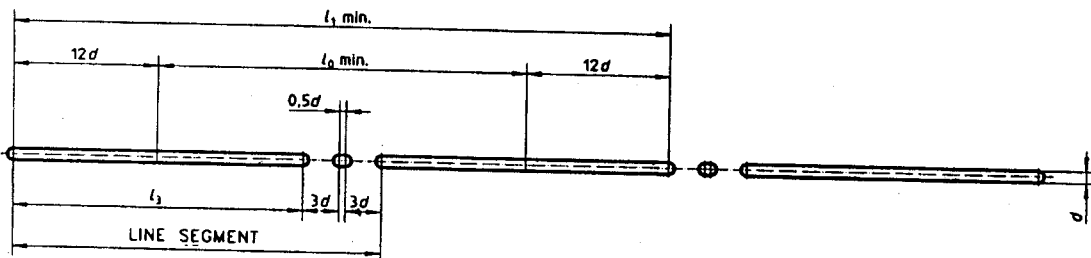


FIG. 6.20

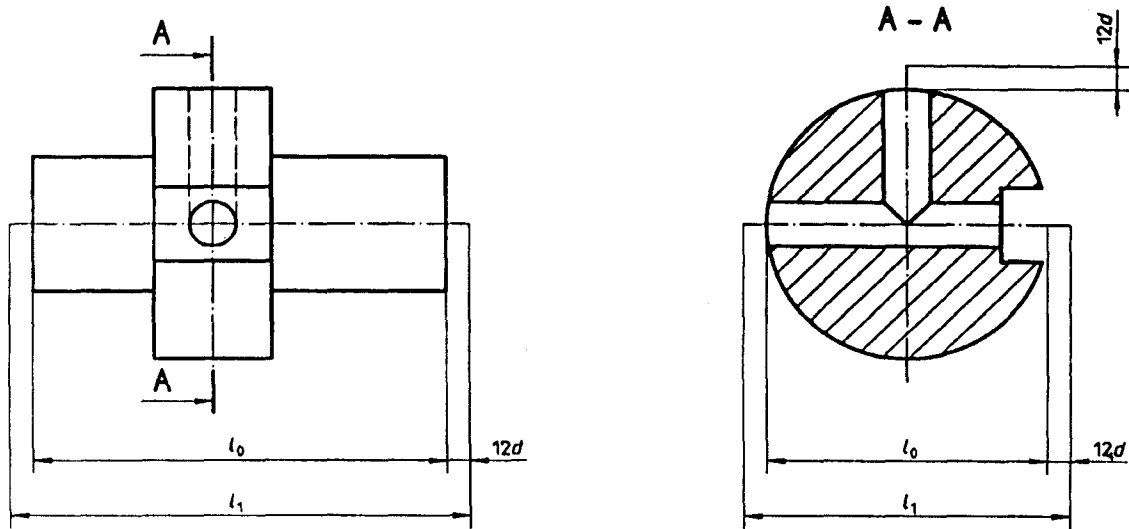


FIG. 6.21

c) Length of the long dashes:

$$l_3 = \frac{l_1 - 6.5 dn}{n + 1}$$

d) Minimum length of this line:

$$l_{1 \min} = 54.5 d$$

Lines shorter than $l_1 = 54.5 d$ shall be drawn as continuous narrow lines. In order to comply with the requirements of 5 of IS 10714 (Part 20), the length of the long dashes of this line may be decreased or increased.

Example

$$l_0 = 125 \quad d = 0.25$$

$$l_1 = 125 + 6 = 131$$

$$n = \frac{131 - 6}{7.625} = 16.393 \hat{=} 16$$

$$l_3 = \frac{131 - 26.00}{17} = 6.176$$

Interpretation of the result— A long dashed dotted line of length 131 mm and line width 0.25 mm, consists of 16 line segments of length 7.801 mm (6.176 mm + 0.750 mm + 0.125 mm + 0.750 mm) and 1 long dash of length 6.176 mm.

6.8.3 Line Type No. 05 (Long Dashed Double-dotted Line)

See Fig. 6.22 for the configuration of this type of line.

Example

See Fig. 6.23.

Formulae:

a) Length of the line:

$$l_1 = l_0 - x$$

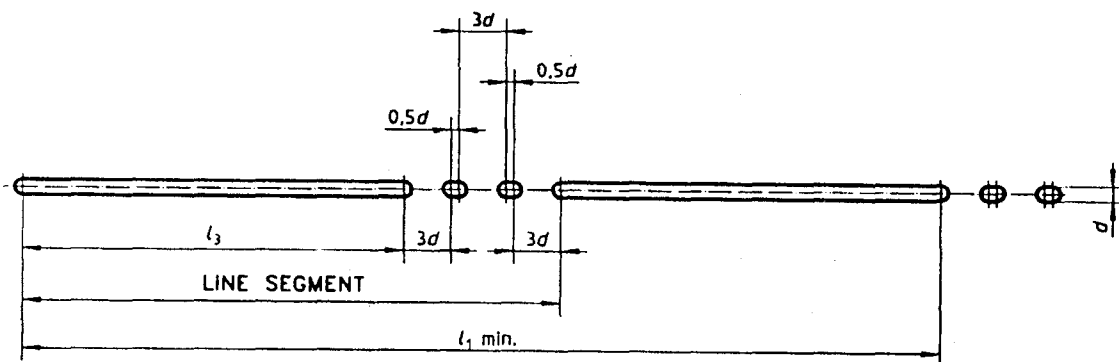


FIG. 6.22

b) Number of line segments within the line:

$$n = \frac{l_1 - 24 d}{34 d} \text{ (rounded)}$$

c) Length of the long dashes:

$$l_3 = \frac{l_1 - 10 dn}{n + 1}$$

d) Minimum length of this line:

$$l_{1 \text{ min}} = 58 d$$

Lines shorter than $l_1 = 58 d$ shall be drawn at a larger scale, in accordance with IS 10713.

It is permissible to draw the long dashes with a change in direction, see Fig. 6.24.

In order to comply with the requirements of 5 of IS 10714 (Part 20), the length of the long dashes of this line may be increased or decreased.

Example

$$l_0 = 128 \quad d = 0.35 \quad \frac{x}{2} = 1.5$$

$$l_1 = 128 - 3 = 125$$

$$n = \frac{125 - 8.4}{11.9} = 9.789 \hat{=} 10$$

$$l_3 = \frac{125 - 35.00}{11} = 8.182$$

6.8.4 Line Type No. 07 (Dotted Line)

See Fig. 6.25 for the configuration of this type of line.

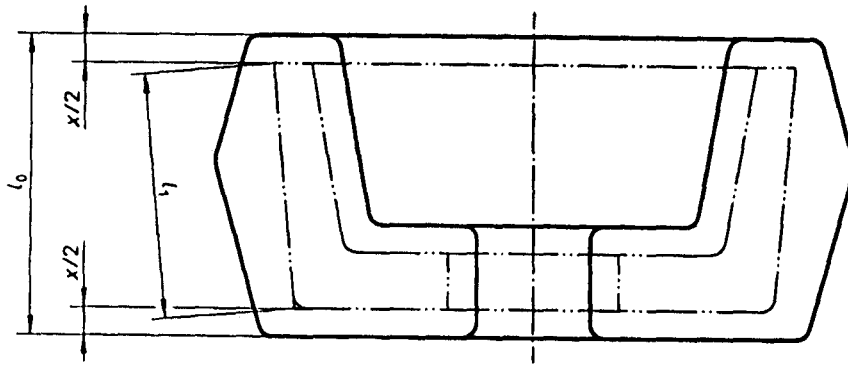


FIG. 6.23



FIG. 6.24

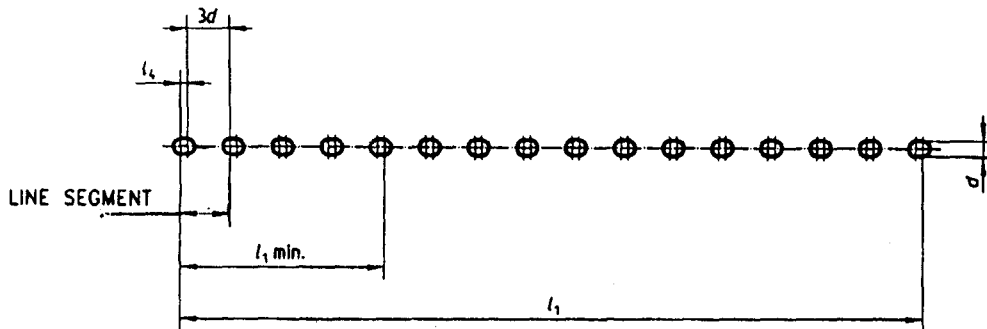


FIG. 6.25

Example

See Fig. 6.26.

Formulae:

- a) Length of the line: $l_1 = l_0$
- b) Number of line segments within the line:

$$n = \frac{l_1 - 0.5 d}{3.5 d} \text{ (rounded)}$$

- c) Length of the dots:

$$l_4 = \frac{l_1 - 3 dn}{n + 1}$$

- d) Minimum length of this line:

$$l_{1 \text{ min}} = 7.5 d$$

Example

$$l_1 = 125 \quad d = 0.5$$

$$n = \frac{125 - 0.25}{1.75} = 71.286 \hat{=} 71$$

$$l_4 = \frac{125 - 106.5}{72} = 0.257$$

6.8.5 Line Type No. 08 (Long Dashed Short Dashed Line)

The conditions for this line type are the same as those for type No. 04 but the formulae are slightly modified as follows.

- a) Length of the line: $l_1 = l_0$
- b) Number of line segments within the line:

$$n = \frac{l_1 - 24 d}{32 d} \text{ (rounded)}$$

- c) Length of the long dashes:

$$l_3 = \frac{l_1 - 12 dn}{n + 1}$$

Length of the short dashes: $6 d$ (see Table 6.3)

- d) Minimum length of this line:

$$l_{1 \text{ min}} = 60 d$$

Example

$$l_1 = 125 \quad d = 0.5$$

$$n = \frac{125 - 12}{16} = 7.063 \hat{=} 7$$

$$l_3 = \frac{125 - 42}{8} = 10.375$$

6.8.6 Line Type No. 09 (Long Dashed Double-Short Dashed Line)

The conditions for this line type are similar to those for type No. 05 and the formulae (b), (c) and (d) are slightly modified as follows:

- a) Length of the line: $l_1 = l_0$
- b) Number of line segments within the line:

$$n = \frac{l_1 - 24 d}{45 d} \text{ (rounded)}$$

- c) Length of the long dashes:

$$l_3 = \frac{l_1 - 21 dn}{n + 1}$$

Length of the short dashes: $6 d$ (see Table 6.3).

- d) Minimum length of this line: $l_{1 \text{ min}} = 69 d$

Example

$$l_1 = 125 \quad d = 0.25$$

$$n = \frac{125 - 6}{11.25} = 10.578 \hat{=} 11$$

$$l_3 = \frac{125 - 57.75}{12} = 5.604$$

6.8.7 Examples of Combinations of Basic Types of Line

6.8.7.1 Two types of lines superimposed

See Fig. 6.27 for the configuration of this type of line.

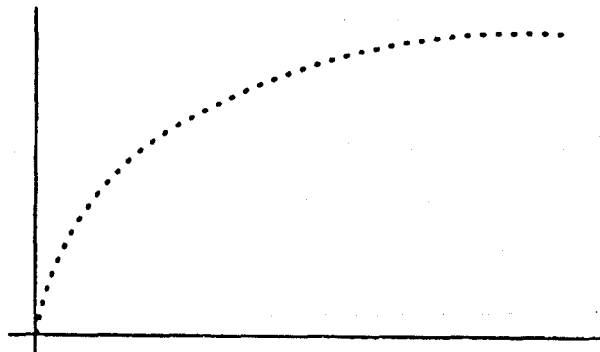
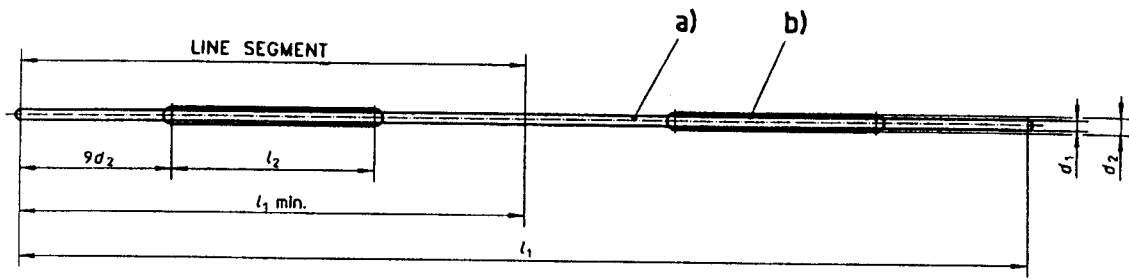


FIG. 6.26



- a): Continuous line No. 01: line width, e.g. 0,25 mm
- b): Dashed spaced line No. 03: line width, e.g. 0,5 mm

FIG. 6.27

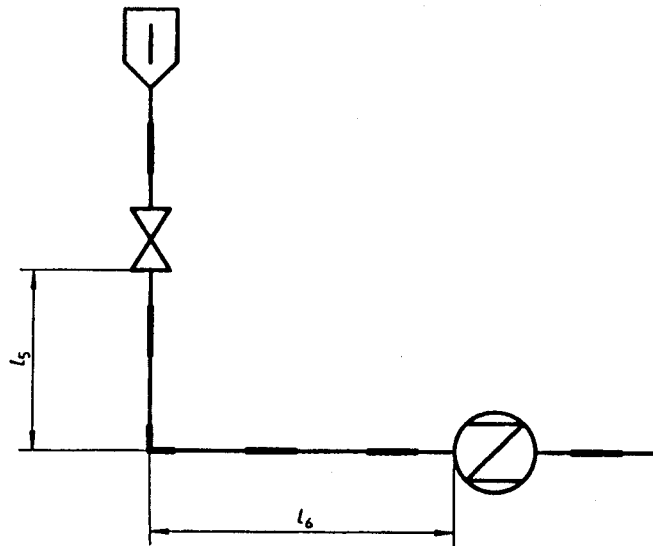


FIG. 6.28

Example

See Fig. 6.28.

Formulae:

- a) Length of the line: $l_1 = l_5 + l_6$
- b) Number of line segments within the line:

$$n = \frac{l_1}{30 d_2} \text{ (rounded)}$$
- c) Length of the dashes:

$$l_2 = \frac{l_1 - 18 d_2 n}{n}$$
- d) Minimum length of this line: $l_{1 \min} = 30 d_2$

Example

$l_1 = 125$ $d_1 = 0.25$ $d_2 = 0.5$

$n = \frac{125}{15} = 8.333 \hat{=} 8$

$l_2 = \frac{125 - 72}{8} = 6.625$

Interpretation of the result—This line consists of a continuous line 125 mm long and 0.25 mm wide as well as a dashed spaced line of width 0.5 mm and 8 dashes of length 6.625 mm, spaced 9 mm apart ($18 d_2$, see Table 6.3). The ends are 4.5 mm in length ($9 d_2$).

6.8.7.2 Line with zigzags

See Fig. 6.29 for the configuration of this type of line.

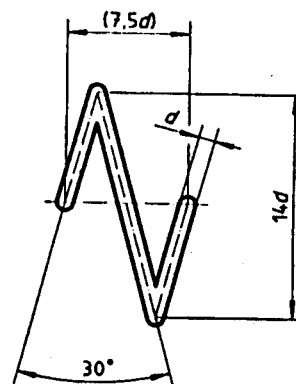


FIG. 6.29

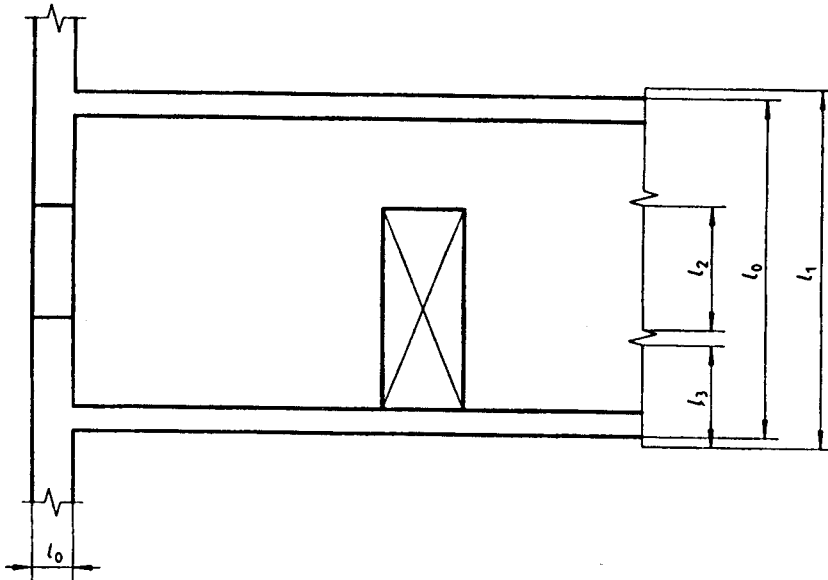


FIG. 6.30

Examples

See Fig. 6.30 and 6.31.

Formulae:

a) Length of the line:

$$l_1 = l_0 + 10 d$$

b) Number of zigzags within the line:

$$n = \frac{l_1}{80} + 1 \text{ (rounded, } l_1 < 40 \text{ makes } n = 1)$$

c) Length of the dashes between the zigzags:

$$l_2 = \frac{l_1}{n} - 7.5 d$$

d) Length of the dashes at the ends of the line:

— if two or more zigzags:

$$l_3 = \frac{l_2}{2}$$

— if one zigzag:

$$l_3 = \frac{l_1 - 7.5 d}{2}$$

If $l_0 \leq 10 d$, the zigzag shall be arranged as shown in Fig. 6.31.

Example

$$l_0 = 125 \quad d = 0.25$$

$$l_1 = 125 + 2.5 = 127.5$$

$$n = \frac{127.5}{80} + 1 = 2.594 \hat{=} 3$$

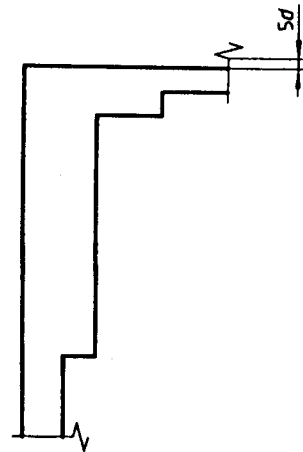


FIG. 6.31

$$l_2 = \frac{127.5}{3} - (7.5 \times 0.25) = 40.625$$

$$l_3 = \frac{40.625}{2} = 20.313$$

Interpretation of the result— A line with zigzags of a length of 127.5 mm and a line width of 0.25 mm is drawn with 3 zigzags. The distance between the zigzags is 40.625 mm and the length of the dashes at the ends is 20.313 mm.

6.8.7.3 “Railway” line

See Fig. 6.32 for the configuration of this type of line.

Example

See Fig. 6.33.

$$l_2 = \frac{125 - 75.60}{12 + 1} = 3.800$$

Formulae:

- a) Length of the line: $l_1 = l_0$
- b) Number of line segments within the line:

$$n = \frac{l_1 - 12d}{30d} \text{ (rounded)}$$

- c) Length of the dashes:

$$l_2 = \frac{l_1 - 18dn}{n + 1}$$

- d) Minimum length of this line:

$$l_{1 \text{ min}} = 42d$$

Example

$$l_1 = 125 \qquad d = 0.35$$

$$n = \frac{125 - 4.2}{10.5} = 11.505 \hat{=} 12$$

Interpretation of the result— A ‘railway’ line of length 125 mm and line width 1.4 mm (4×0.35 mm) consists of 12 complete line segments of length 10.100 mm (3.800 mm + 6.300 mm) and one dash of length 3.800 mm.

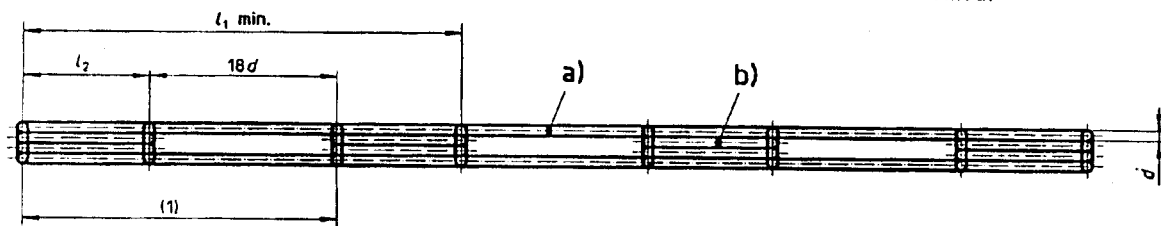
6.9 Terms and Definitions

6.9.1 Leader Line

Continuous narrow line which establishes the connection between the features of a graphical representation and additional alphanumeric and/or written instructions (notes, technical requirements, item references, etc) in an unambiguous manner.

6.9.2 Reference Line

Continuous narrow line connecting with the leader line horizontally or vertically and on or at which the additional instructions are indicated.



- (1): Line segment
- a) Continuous line No. 01.
- b) Dashed spaced line No. 03.

FIG. 6.32

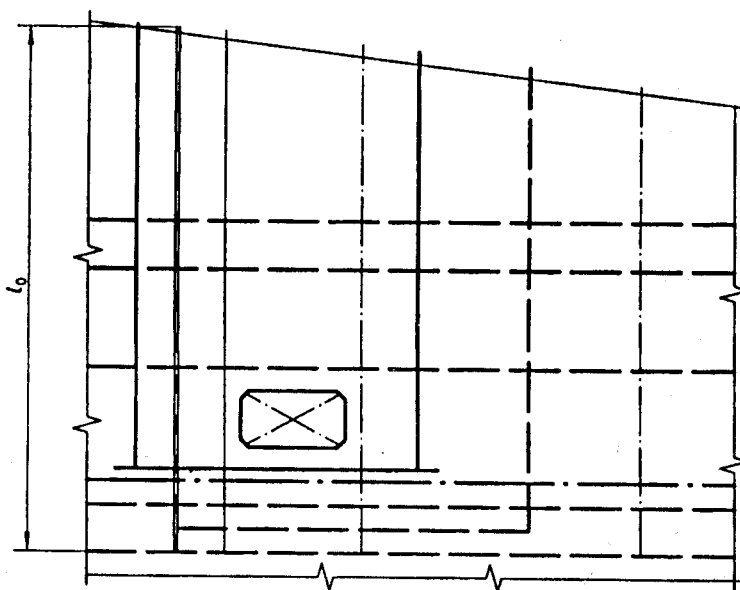


FIG. 6.33

6.10 Presentation of Leader Lines

Leader lines are executed as continuous narrow lines in accordance with IS 10714 (Part 20). They are drawn preferably at an angle to the relevant representation and/or the frame limiting the drawing sheet, and not parallel to adjacent lines, for example, hatching lines. The inclination to the relevant lines shall be $> 15^\circ$ (see Fig. 6.34 to 6.46).

Leader lines may be drawn with sharp kinks (see Fig. 6.38), and two or more leader lines may be joined up (see Fig. 6.35, 6.38, 6.40, 6.41 and 6.44). They should not cross other leader lines, reference lines or indications, such as, graphical symbols or dimensional values.

Leader lines shall terminate at the end which touches the features as follows:

- with a closed and filled or a closed arrowhead (included angle 15°) if the leader line ends at lines which represent outlines or edges of parts, pipings or cables in plans, charts or diagrams; arrowheads are also drawn at crossing points of these lines with other lines, for example, lines of symmetry (see the examples given in Fig. 6.34 to 6.40);

NOTE — If several parallel lines have to be designated, oblique strokes instead of arrowheads are permitted (see IEC 61082-1). See the example given in Fig 6.41.

- with a dot ($d = 5 \times$ line width) if the leader line ends within the outlines of an object (see the examples given in Fig. 6.42 to 6.44);
- without any termination if the leader line ends at another line, for example, dimension line or line of symmetry (see the examples given in Fig. 6.45 and 6.46).

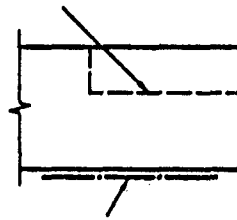


FIG. 6.36

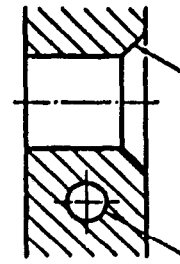


FIG. 6.37

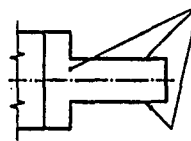


FIG. 6.38



FIG. 6.39

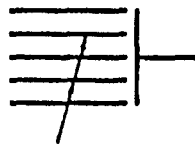


FIG. 6.40

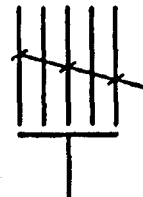


FIG. 6.41

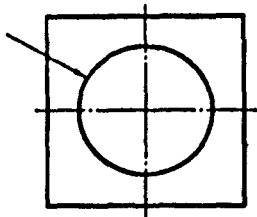


FIG. 6.34

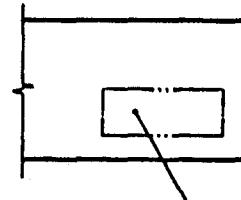


FIG. 6.42

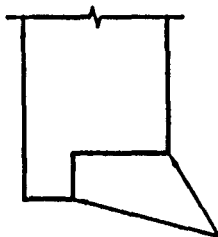


FIG. 6.35

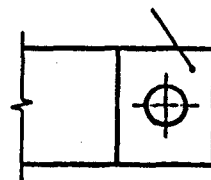


FIG. 6.43

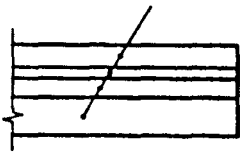


FIG. 6.44

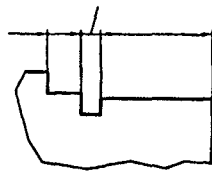


FIG. 6.45

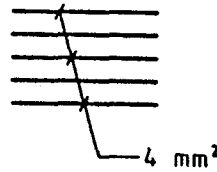


FIG. 6.49

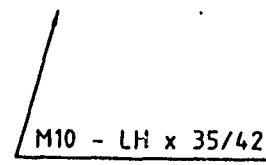


FIG. 6.50

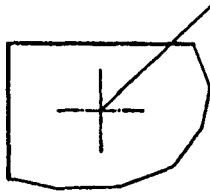


FIG. 6.46

In particular cases of application the reference line has to be drawn (see the example given in Fig. 6.48).

However, the reference line may be omitted, if the leader line is drawn in one of the reading directions of the drawing and if the indicated instructions are written in the same direction (see the example given in Fig. 6.51), and in all other cases in which this line is not applicable (see the examples given in Fig. 6.45, 6.52 and 6.53).

6.11 Presentation of Reference Lines

Reference lines are executed as continuous narrow lines in accordance with IS 10714 (Part 20). A reference line may be added to each leader line. It is drawn in one of the reading directions of the drawing.

The reference line shall be drawn

- either with a fixed length, for example, 20 × line width of the reference line (see the examples given in Fig. 6.48 and 6.49),
- or with a length adapted to the length of the indicated instructions (see the examples given in Fig. 6.47, 6.50, 6.54 and 6.55).

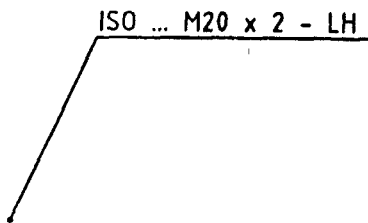


FIG. 6.47

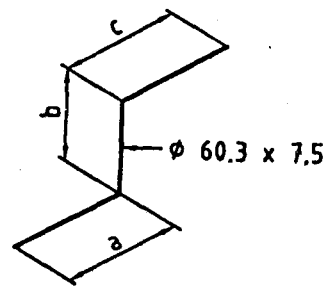


FIG. 6.51

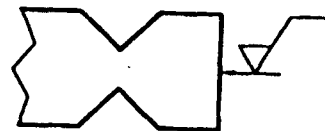


FIG. 6.52



FIG. 6.53

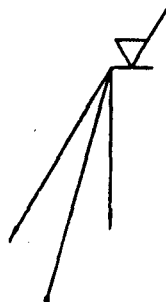


FIG. 6.48

6.12 Indication of Instructions

The instructions belonging to the leader lines shall be indicated as follows:

- preferably above the reference line (see the example given in Fig. 6.47, 6.50, 6.54 and 6.55 and in 6.13);
- centrically behind the leader or reference line (see the examples given in Fig. 6.49 and 6.51); or

— around, within or behind graphical symbols according to the valid Indian Standards (see the example given in Fig. 6.54 and 6.55 and in 6.13).

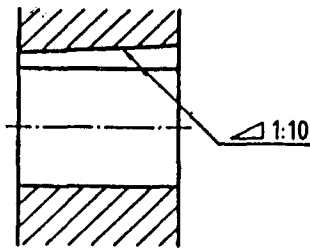


FIG. 6.54

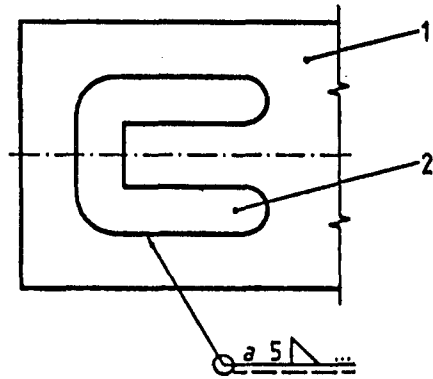


FIG. 6.56

Taking into account the requirements for microcopying in IS 10164, the instructions should be written at a distance of twice the line width of the reference line above or below the reference line. They should not be drawn within the reference line and they should not touch it.

If individual layers or assembled parts of an object are designated with one leader line, the order of the indications shall correspond with the order of the layers or the parts (see the example given in Fig. 6.55).

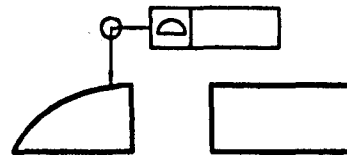


FIG. 6.57

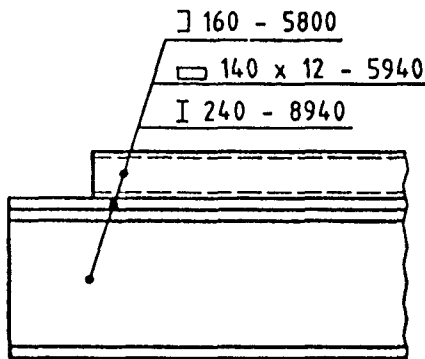


FIG. 6.55

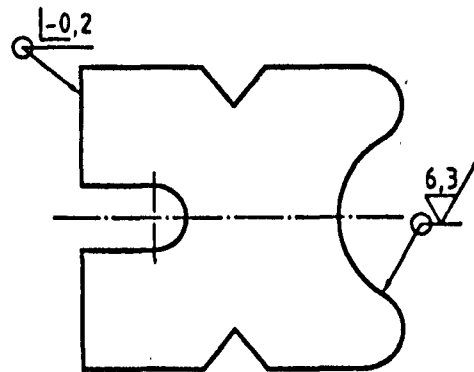


FIG. 6.58

6.13 Graphical Supplements Contained in Other Indian Standards (see Table 6.4)

6.14 Meaning and Application of the Graphical Supplement 'Circle' for Leader Lines

The same required characteristic on a number of surfaces or corners of a part connected to each other may be indicated only once if a circle ($d = 8 \times$ width of the leader line) is drawn at the connecting point of the leader line and the reference line (see Fig. 6.56 to 6.58). This means that the same requirements apply to all surfaces or corners around the contour or profile of the represented part.

The 'circle' sign shall not be used if either or both of the following occur:

- a) the indications are ambiguous, and
- b) the indication concerns all surfaces or corners of a part.

6.15 Types of Lines and Their Applications in Construction Drawings

The first part of the number is the number of line type in IS 10714 (Part 20) (see Table 6.5).

Table 6.4 Graphical Supplements
(Clause 6.13)

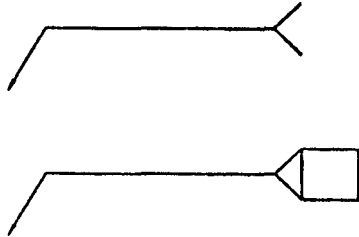


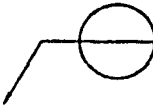
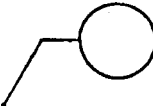
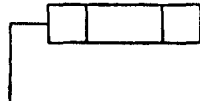

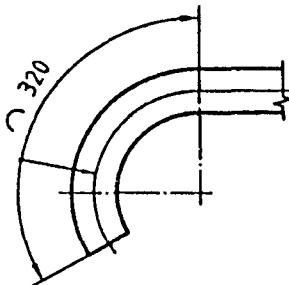
No.	Graphical supplement	Application
1		Indication of further information concerning welds, e.g. the number of the welding process
2		Designation of a field or site weld
3		Identification of the location of a weld
4		Datum target frame
5		Indication of item references (ISO 6433 does not specify only this method)
6		Frame used for geometrical tolerance requirements
7		Indication of several toleranced features
8		Indication of dimensions of arc lengths

Table 6.4—(Concluded)
(Clause 6.13)

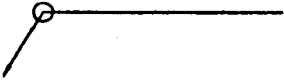
No.	Graphical supplement	Application
9		<p>This sign (circle) has the following meanings in the International Standards mentioned below:</p> <ul style="list-style-type: none"> — geometrical (profile) tolerance all around the profile — profile tolerance of the entire outline of the cross section — surface texture on all surfaces around a part — roughness on all surfaces — a peripheral weld all around a part — features, e.g. burr, all around a part — machining allowance which applies to all surfaces — the same state of corner all around a part

Table 6.5 Types of Lines and their Application in Construction Drawings
(Clause 6.15)

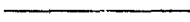
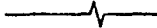
No.	Description and representation	Application
01.1	Continuous narrow line 	.1 boundaries of different materials in view, cut and section (alternatively, see 01.2.2) .2 hatching .3 diagonals for indication of openings, holes and recesses .4 arrow lines in stairs, ramps and sloping areas .5 modular grid lines, first stage (if necessary, other colour than outlines) .6 short centrelines .7 extension lines .8 dimension lines and their terminators .9 leader lines .10 existing contours on landscape drawings (alternatively, see 02.1.1) .11 visible outlines of parts in view (alternatively, see 01.2.3) .12 simplified representation of doors, windows, stairs, fittings etc. (alternatively, see 01.2.4) .13 framing of details
	Continuous narrow lines with zigzags 	.14 limits of partial or interrupted views, cuts and sections, if the limit is not a line 04.1 (alternatively, see 04.1.6)

Table 6.5 — (Continued)













No.	Description and representation	Application
01.2	Continuous wide line 	.1 visible outlines of parts in cut and section when hatching is used .2 boundaries of different materials in view, cut and section (alternatively, see 01.1.1) .3 visible outlines of parts in view (alternatively, see 01.1.11) .4 simplified representation of doors, windows, stairs, fittings etc. (alternatively, see 01.1.12) .5 modular grid lines, second stage (if necessary other colour than outlines) .6 arrow lines for marking of views, cuts and sections .7 proposed contours on landscape drawings
01.3	Continuous extra-wide line 	.1 visible outlines of parts in cut and section when hatching is not used .2 reinforcing bars (see 02.3.1) .3 lines of special importance
02.1	Dashed narrow line 	.1 existing contours on landscape drawings (alternatively, see 01.1.10) .2 subdivision of plant beds/grass .3 hidden outlines (alternatively, see 02.2.1)
02.2	Dashed wide line 	.1 hidden outlines (alternatively, see 02.1.3)
02.3	Dashed extra-wide line 	.1 reinforcing bars in bottom layer on plan and far face layer in elevation when bottom and top layers and near and far face layers are shown on the same sketch
04.1	Long dashed dotted narrow line 	.1 cutting planes (line 04.2 at ends and changes of direction) .2 centrelines .3 lines of symmetry (identified at the ends by two narrow short parallel lines drawn at right angle) .4 framing of enlarged details .5 reference lines .6 limits of partial or interrupted views, cuts and sections (especially for short lines and in narrow situations; see examples 01.1.2, 01.2.1, 01.3.1, etc., in annex A; alternatively, see 01.1.14)

Table 6.5 — (Continued)

No.	Description and representation	Application
04.2	Long dashed dotted wide line 	.1 cutting planes (at ends and changes of direction; see 04.1.1)
		.2 outlines of visible parts situated in front of the cutting plane
04.3	Long dashed dotted extra-wide line 	.1 secondary lines for setting out and arbitrary reference lines
		.2 indication of lines or surfaces to which a special requirement applies
		.3 boundary lines for contracts, stages, zones etc.
05.1	Long dashed double-dotted narrow line 	.1 alternative and extreme positions of movable parts
		.2 centroidal line
		.3 outlines of adjacent parts
05.2	Long dashed double-dotted wide line 	.1 outlines of hidden parts situated in front of the cutting plane
05.3	Long dashed double-dotted extra-wide line 	.1 reinforcing prestressed bars and cables
07.1	Dotted narrow line 	.1 outlines of parts not included in the project

6.16 Line Widths

On a construction drawing three line widths, narrow, wide and extra-wide, are normally used (*see* Table 6.6).

The proportions between the line widths are 1 : 2 : 4.

A special line width is used for representation and lettering of graphical symbols. This line width is situated between the width of the narrow and the wide line.

The line widths shall be chosen according to the type, size and scale of the drawing and the requirements at microcopying and other methods of reproduction.

Table 6.6 Line Widths
(Clause 6.16)

All dimensions in millimetres.

Line Group	Narrow Line	Wide Line	Extra-Wide Line
0.25	0.13	0.25	0.5
0.35	0.18	0.35	0.7
0.5	0.25	0.5	1
0.7	0.35	0.7	1.4
1	0.5	1	2

6.17 Examples of Application for Construction Drawings

Examples of the application for construction drawings of the different types of lines, along with the corresponding reference numbers from 6.15, are given in Table 6.7.

Table 6.7 Examples of Application for Construction Drawings
(Clause 6.17)

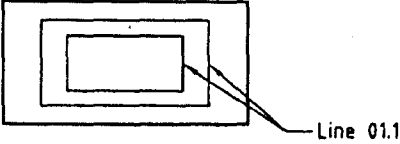
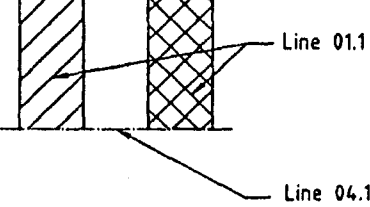
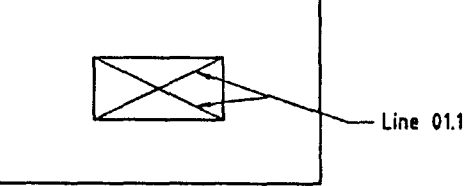
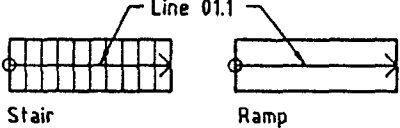
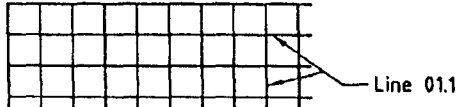
No.	Line type	Example of application
01.1	Continuous narrow line	
01.1.1	Boundaries of different materials in view, cut and section	 <p>View of a floor with different materials</p>
01.1.2	Hatching	 <p>Vertical section of a wall</p>
01.1.3	Diagonals for indication of openings, holes and recesses	 <p>View of a wall with an opening</p>
01.1.4	Arrow lines in stairs, ramps and sloping areas	 <p>Stair Ramp</p>
01.1.5	Modular grid lines, first stage	

Table 6.7 — (Continued)


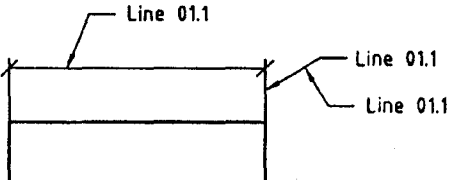

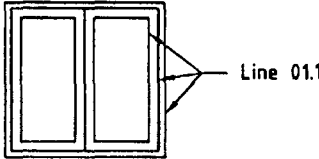
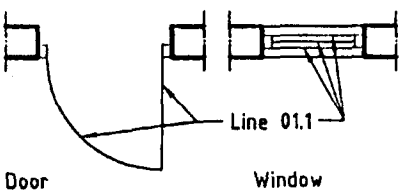
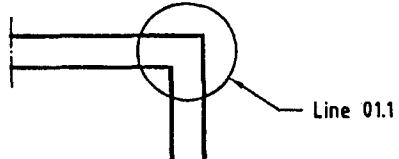
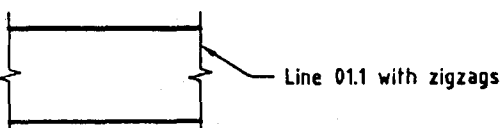
No.	Line type	Example of application
01.1.6	Short centrelines	
01.1.7 01.1.8 01.1.9	Extension lines Dimension lines and their terminators Leader lines	
01.1.10	Existing contours on landscape drawings	
01.1.11	Visible outlines of parts in view (alternatively, see 01.2.3)	
01.1.12	Simplified representation of doors, windows, stairs, fittings etc. (alternatively, see 01.2.4)	
01.1.13	Framing of details	
01.1.14	Limits of partial or interrupted views, cuts and sections, if the limit is not a line 04.1	

Table 6.7 — (Continued)

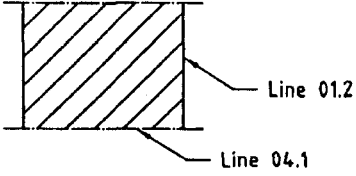
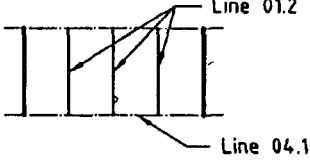
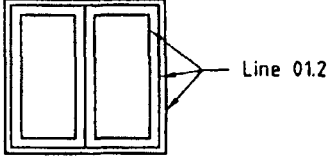
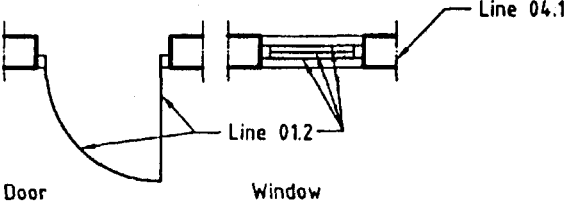
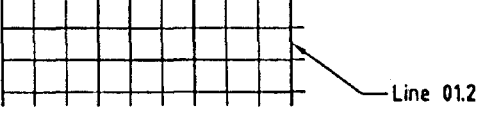
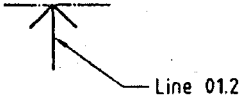
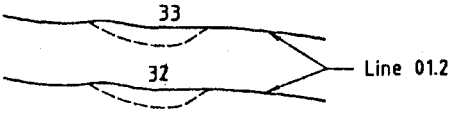
No.	Line type	Example of application
01.2	Continuous wide line	
01.2.1	Visible outlines of parts in cut and section when hatching is used	
01.2.2	Boundaries of different materials in view, cut and section	
01.2.3	Visible outlines of parts in view (alternatively, see 01.1.11)	
01.2.4	Simplified representation of doors, windows, stairs, fittings etc. (alternatively, see 01.1.12)	
01.2.5	Modular grid lines, second stage	
01.2.6	Arrow lines for marking of views, cuts and sections	
01.2.7	Proposed contours on landscape drawings	

Table 6.7 — (Continued)

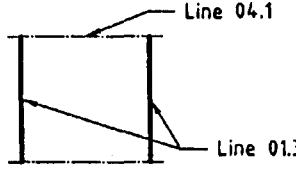
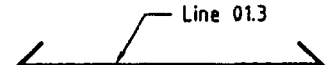
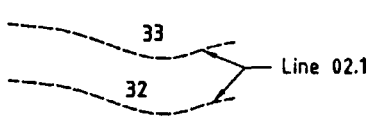

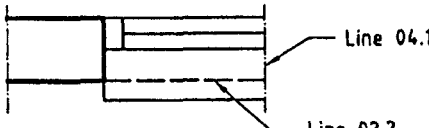
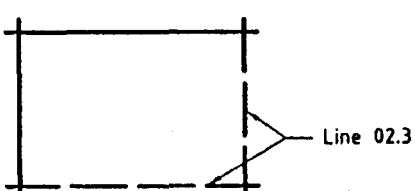
No.	Line type	Example of application
01.3	Continuous extra-wide line	
01.3.1	Visible outlines of parts in cut and section when hatching is not used	 <p style="text-align: center;">Vertical section of a wall</p>
01.3.2	Reinforcing bars	
02.1	Dashed narrow line	
02.1.1	Existing contours on landscape drawings (alternatively, see 01.1.10)	
02.1.2	Subdivision of plant beds/grass	
02.2	Dashed wide line	
02.2.1	Hidden outlines	
02.3	Dashed extra-wide line	
02.3.1	Reinforcing bars in bottom layer on plan and far face layer in elevation when bottom and top layers are shown on the same sketch	

Table 6.7 — (Continued)

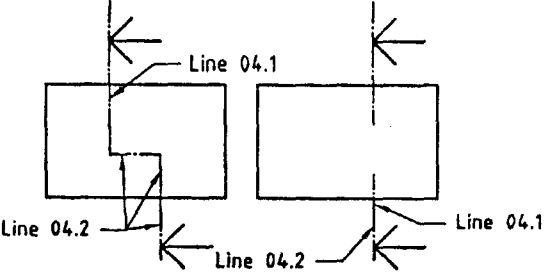
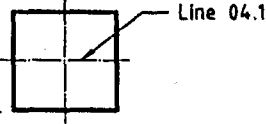
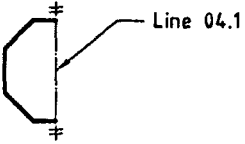
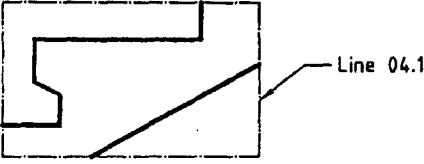
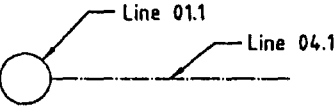
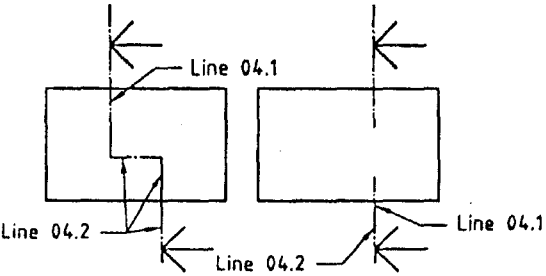
No.	Line type	Example of application
04.1	Long dashed dotted narrow line	
04.1.1	Cutting planes (drawn with line 04.2 at ends and changes of direction)	
04.1.2	Centrelines	
04.1.3	Lines of symmetry	
04.1.4	Framing of enlarged details	
04.1.5	Reference lines	
04.2	Long dashed dotted wide line	
04.2.1	Cutting planes (drawn with line 04.2 at ends and changes of direction; the rest is drawn with line 04.1)	

Table 6.7 — (Continued)

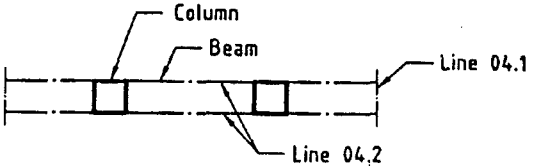
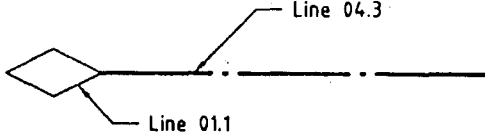
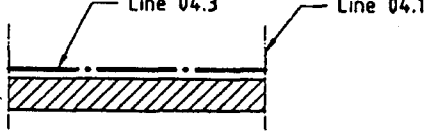
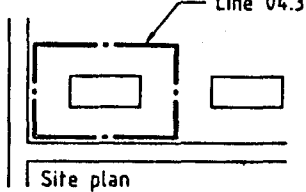
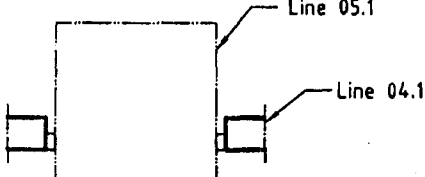
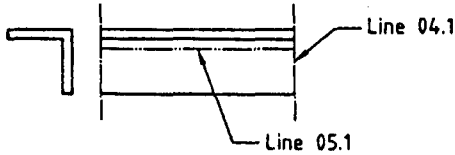
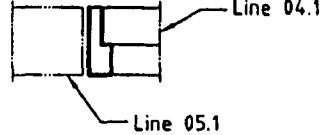
No.	Line type	Example of application
04.2.2	Outlines of visible parts situated in front of the cutting plane	
04.3	Long dashed dotted extra-wide line	
04.3.1	Secondary lines for setting out and arbitrary reference lines	
04.3.2	Indication of lines or surfaces to which a special requirement applies	
04.3.3	Boundary lines for contracts, stages, zones, etc.	
05.1	Long dashed double-dotted narrow line	
05.1.1	Alternative and extreme position of movable parts	
05.1.2	Centroidal lines	
05.1.3	Outlines of adjacent parts	

Table 6.7 — (Concluded)

No.	Line type	Example of application
05.2	Long dashed double-dotted wide line	
05.2.1	Outlines of hidden parts situated in front of the cutting plane	
05.3	Long dashed double-dotted extra-wide line	
05.3.1	Reinforcing prestressed bars and cables	
07	Dotted narrow line	
07.1	Outlines of parts not included in the project	

6.18 Types of Lines and Their Application in Mechanical Engineering Drawings

The first part of the line number in Table 6.8 is the number of the basic type in accordance with IS 10714 (Part 20).

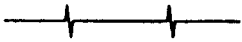



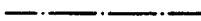


Examples of application are given in Table 6.10.

6.19 Line Widths and Line Groups

On mechanical engineering drawings two line widths are normally used. The proportions between the line widths should be 1 : 2.

The line groups are specified as shown in Table 6.9.

Table 6.8 — (Concluded)

No.	Line Description and representation	Application
01.1	Continuous narrow line with zigzags 	.19 preferably mechanically represented termination of partial or interrupted views, cuts and sections, if the limit is not a line of symmetry or a centre line ^a
01.2	Continuous wide line 	.1 visible edges
		.2 visible outlines
		.3 crests of screw threads
		.4 limit of length of full depth thread
		.5 main representations in diagrams, maps, flow charts
		.6 system lines (structural metal engineering)
		.7 parting lines of moulds in views
		.8 lines of cuts and section arrows
02.1	Dashed narrow line 	.1 hidden edges
		.2 hidden outlines
02.2	Dashed wide line 	.1 indication of permissible areas of surface treatment
04.1	Long-dashed dotted narrow line 	.1 centre lines
		.2 lines of symmetry
		.3 pitch circle of gears
		.4 pitch circle of holes
04.2	Long-dashed dotted wide line 	.1 indication of (limited) required areas of surface treatment, e.g. heat treatment
		.2 indication of cutting planes
05.1	Long-dashed double-dotted narrow line 	.1 outlines of adjacent parts
		.2 extreme positions of movable parts
		.3 centroidal lines
		.4 initial outlines prior to forming
		.5 parts situated in front of a cutting plane
		.6 outlines of alternative executions
		.7 outlines of the finished part within blanks
		.8 framing of particular fields/areas
		.9 projected tolerance zone

^a It is recommended to use only one type of line on one drawing.

Table 6.9 Line Groups
(Clause 6.19)

All dimensions in millimetres.

Line Group	Line Widths for Line No.	
	01.2-02.2-04.2	01.1-02.1-04.1-05.1
0.25	0.25	0.13
0.35	0.35	0.18
0.5 ¹⁾	0.5	0.25
0.7 ¹⁾	0.7	0.35
1	1	0.5
1.4	1.4	0.7
2	2	1

¹⁾ Preferred line groups.

The widths and groups of lines should be chosen according to the type, size and scale of the drawing and according to the requirements for microcopying and/or other methods of reproduction.

6.20 Examples of Application for Mechanical Engineering Drawings

Table 6.10 gives examples of the application for mechanical engineering drawings of the different types of lines indicating the reference number given in Table 6.8. The figures are shown in first angle projection. It is understood that first angle projection could be used as well.

Table 6.10 Examples of Application for Mechanical Engineering Drawings
(Clauses 6.18 and 6.20)

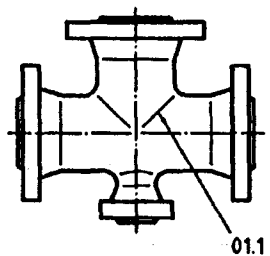
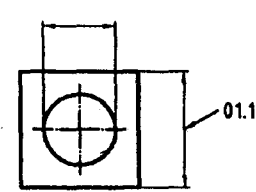
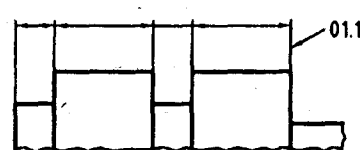

No.	Line Type and Example of Application
01.1	Continuous narrow line
01.1.1	Imaginary lines of intersection 
01.1.2	Dimension lines 
01.1.3	Extension lines 
01.1.4	Leader lines and reference lines 

Table 6.10 — (Continued)

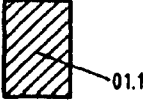
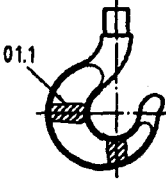

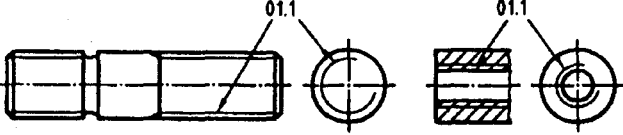
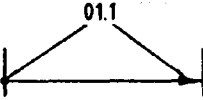
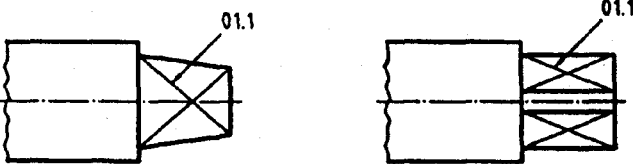
No.	Line Type and Example of Application
01.1.5	Hatching 
01.1.6	Outlines of revolved sections 
01.1.7	Short centre lines 
01.1.8	Root of screw threads 
01.1.9	Dimension line termination 
01.1.10	Diagonals for the indication of flat surfaces 

Table 6.10 — (Continued)

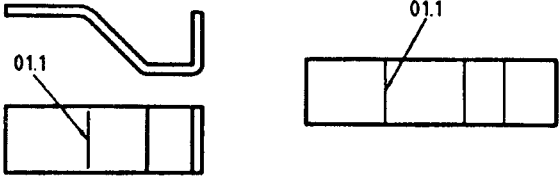
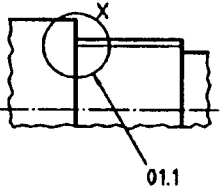
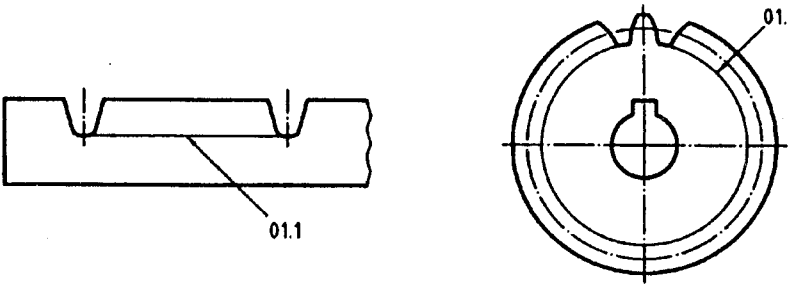
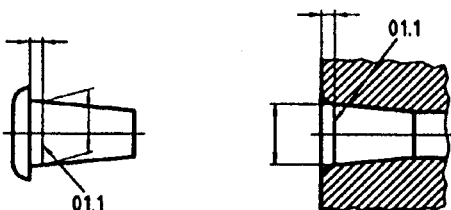
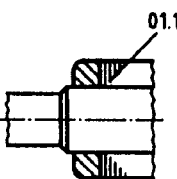
No.	Line Type and Example of Application
01.1.11	<p>Bending lines on blanks and processed parts</p> 
01.1.12	<p>Framing of details</p> 
01.1.13	<p>Indication of repetitive details, e.g. root diameters of gears</p> 
01.1.14	<p>Interpretation lines of tapered features</p> 
01.1.15	<p>Location of laminations, e.g. transformer plates</p> 

Table 6.10 — (Continued)

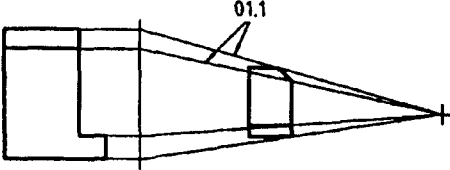
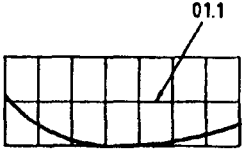
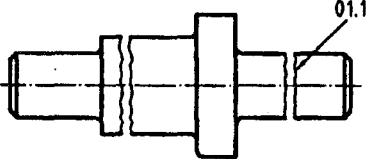
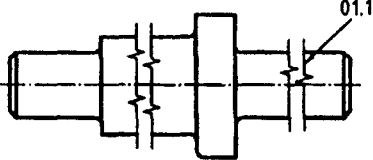
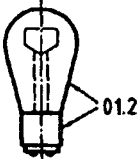
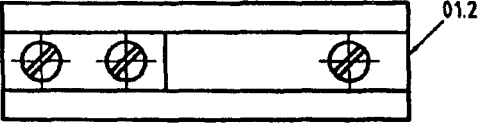
No.	Line Type and Example of Application
01.1.16	<p>Projection lines</p> 
01.1.17	<p>Grid lines</p> 
01.1.18	<p>Continuous narrow freehand lines</p> 
01.1.19	<p>Continuous narrow lines with zigzags</p> 
01.2	<p>Continuous wide line</p>
01.2.1	<p>Visible edges</p> 
01.2.2	<p>Visible outlines</p> 

Table 6.10 — (Continued)

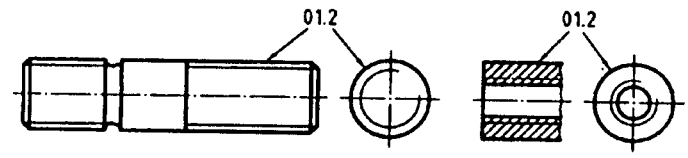
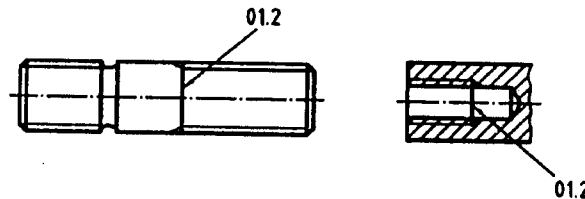
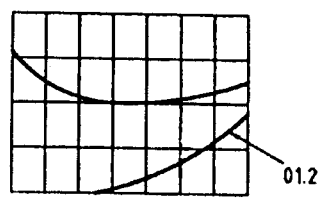
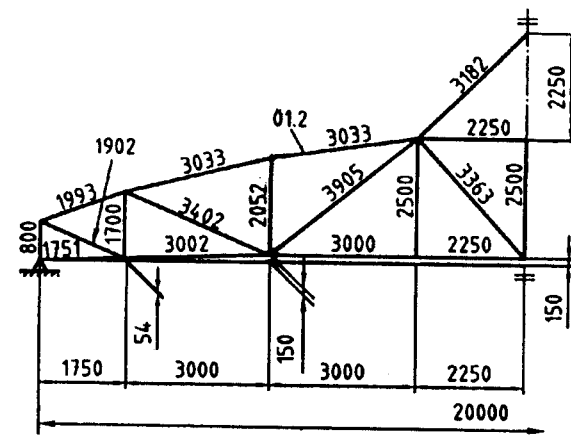
No.	Line Type and Example of Application
01.2.3	<p>Crests of screw threads</p> 
01.2.4	<p>Limit of length of full-depth thread</p> 
01.2.5	<p>Main representations in diagrams, maps, flow charts</p> 
01.2.6	<p>System lines</p> 

Table 6.10 — (Continued)

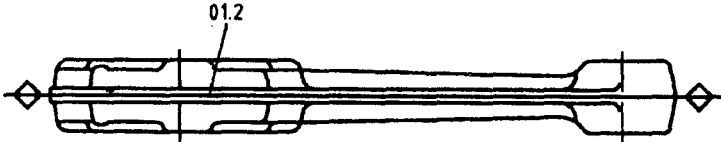
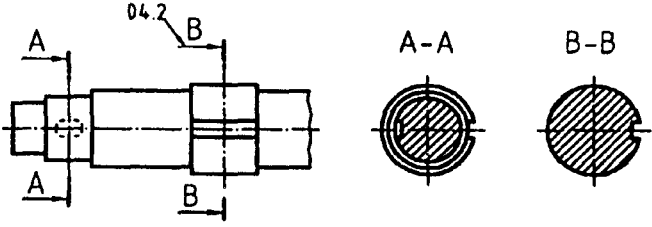
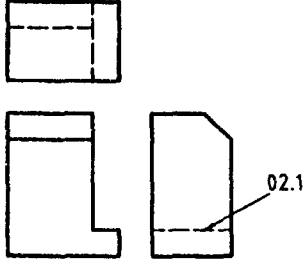
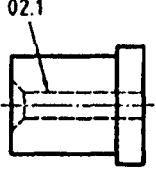
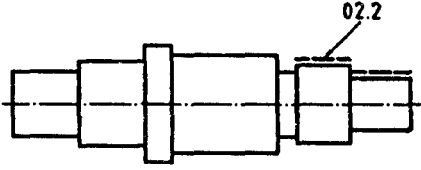
No.	Line Type and Example of Application
01.2.7	<p>Parting lines of moulds in views</p> 
01.2.8	<p>Lines of cuts and section arrows</p> 
02.1	<p>Dashed narrow line</p>
02.1.1	<p>Hidden edges</p> 
02.1.2	<p>Hidden outlines</p> 
02.2	<p>Dashed wide line</p>
02.2.1	<p>Indication of permissible surface treatment</p> 

Table 6.10 — (Continued)

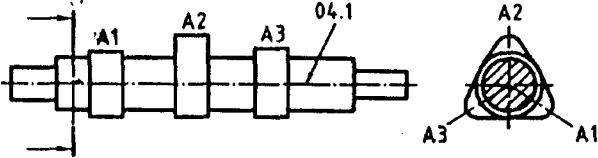
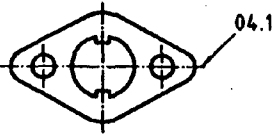
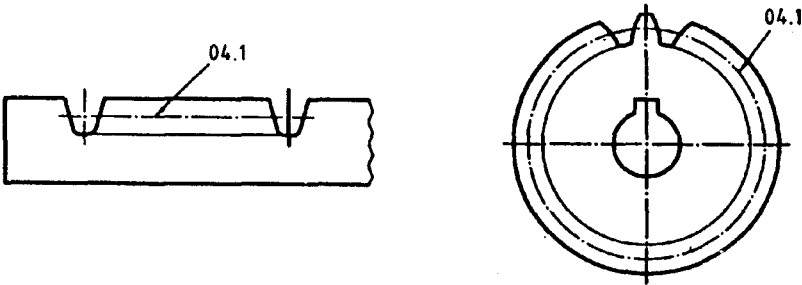
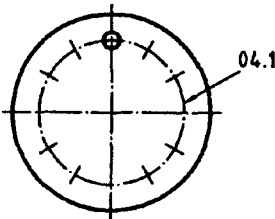
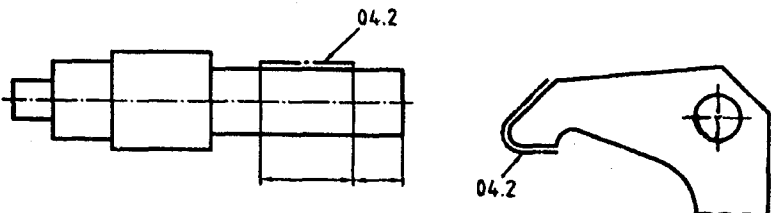
No.	Line Type and Example of Application
04.1	Long-dashed dotted narrow line
04.1.1	<p>Centre lines</p> 
04.1.2	<p>Lines of symmetry</p> 
04.1.3	<p>Pitch circles of gears</p> 
04.1.4	<p>Pitch circles of holes</p> 
04.2	Long-dashed dotted wide line
04.2.1	<p>Indication of limited areas (heat treatment, measuring area)</p> 

Table 6.10 — (Continued)

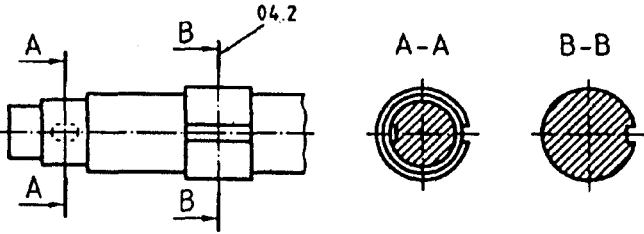
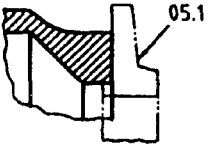
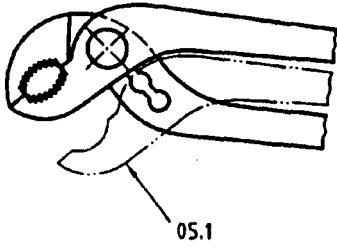
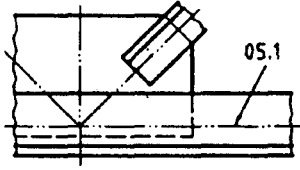
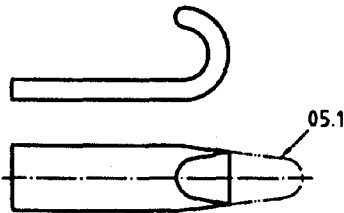
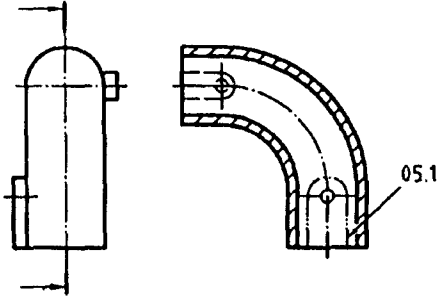
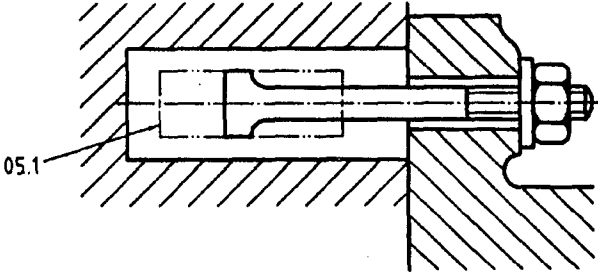
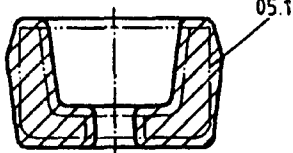
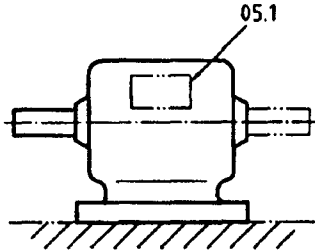
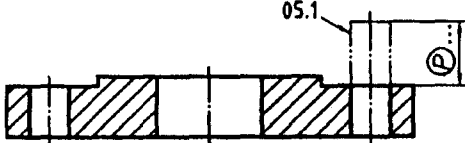
No.	Line Type and Example of Application
04.2.2	<p>Indication of cutting planes</p> 
05.1	<p>Long dashed double-dotted narrow line</p>
05.1.1	<p>Outlines of adjacent parts</p> 
05.1.2	<p>Extreme positions of movable parts</p> 
05.1.3	<p>Centroidal lines</p> 
05.1.4	<p>Initial outlines prior to forming</p> 

Table 6.10 — (Concluded)

No.	Line Type and Example of Application
05.1.5	<p>Parts situated in front of a cutting plane</p> 
05.1.6	<p>Outlines of alternative executions</p> 
05.1.7	<p>Outlines of the finished part within blanks</p> 
05.1.8	<p>Framings of particular fields/areas</p> 
05.1.9	<p>Projected tolerance zone</p> 

SECTION 7 LETTERING

[Based on IS 9609 (Part 0) : 2001/ISO 3098-0 : 1997]

7.1 Scope

This section specifies the general requirements for lettering, in accordance with all other parts of this International Standard, to be used in technical product documentation (in particular on technical drawings).

It includes basic conventions as well as rules for the application of lettering using the following techniques:

- a) free-hand lettering (by means of an underlaid 'grid');
- b) templates (*see* IS/ISO 9178) and manual lettering instruments;
- c) dry transfer systems;
- d) numerically controlled lettering and draughting systems.

7.2 Definitions

For the purposes of this section, the following definitions shall apply.

7.2.1 Central Line

Imaginary line in the middle of each line or line element which is a constitutive part of a graphic character set.

NOTES

1 Lines may be drawn by means of tubular technical pens conforming with ISO 9175-1 and ISO 9175-2.

2 The central line is the basic datum for the design of tools for lettering, for example, engraving tools for templates, programmes for lettering generators.

7.2.2 Graphic Character Set

Finite set of different graphic characters in a fixed type of lettering, including letters of a certain alphabet, numerals, diacritical marks, punctuation marks and additional graphical symbols, that is, considered complete for a given purpose (*see also* ISO 2382-4).

7.2.3 Lettering

- a) Procedure of writing graphic characters taken from a graphic character set on a (technical) drawing carrier (in addition to the graphical representation).
- b) The whole of the non-graphical information on a (technical) drawing carrier (text, instructions, dimensions, etc).
- c) The whole of the graphic characters of a graphic character set which can be used for

transferring non-graphical information onto a (technical) drawing carrier.

7.3 General Requirements

The basic characteristics required of lettering are given in 7.3.1 to 7.3.3.

7.3.1 Legibility, which shall be maintained by a space between characters of twice the line width used for lettering.

This spacing may be reduced to one line width for a better visual effect with combinations of particular characters, for example, LA, TV or Tr.

7.3.2 Suitability for the generally used copying processes (diaz copying, microfilming, telefax, etc).

7.3.3 Suitability for numerically controlled draughting systems.

7.4 Dimensions

7.4.1 Nominal Size

The nominal size of lettering is defined by the height (h) of the outline contour of the upper-case (capital) letters (*see* Fig. 7.1 and Tables 7.1 and 7.2).

The dimensions shown in Fig. 7.1 to 7.3 as applied to the Latin (L) alphabet shall also be applied to the Cyrillic (C) and Greek (G) alphabets.

7.4.2 Location of Central Lines

The nominal size (h) and the spacing between characters (a) shall be taken as the basis for defining the central line (*see* Fig. 7.4 and 7.5). For other dimensions *see* Tables 7.1 and 7.2.

$$h_1 = h - d$$

$$a_1 = a + d$$

When CAD lettering is used [*see* IS 9609 (Part 6)], the same sizes are required as for other techniques.

7.4.3 Range of Nominal Sizes

The range of nominal sizes is specified as follows:

1.8 mm; 2.5 mm; 3.5 mm; 5 mm; 7 mm;
10 mm; 14 mm; 20 mm

The multiple of $\sqrt{2}$ in the range of heights for lettering is derived from the standardized progression of dimensions for paper sizes (*see* ISO 216).

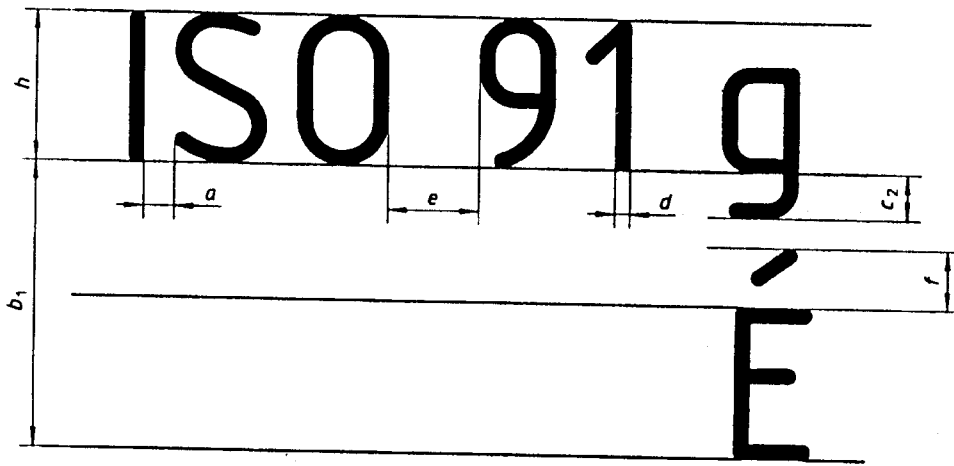


FIG. 7.1

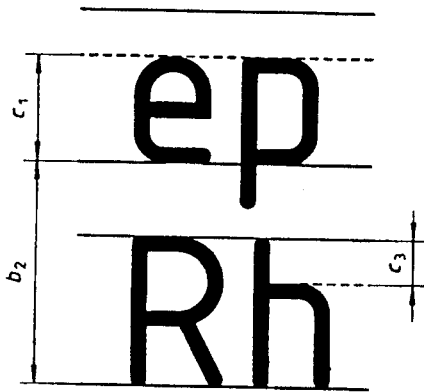


FIG. 7.2

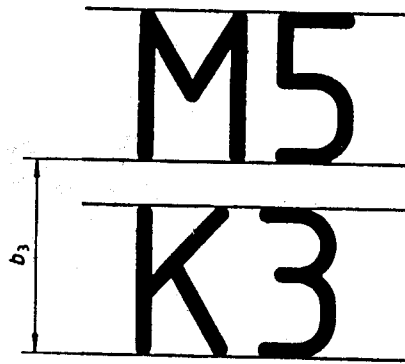


FIG. 7.3

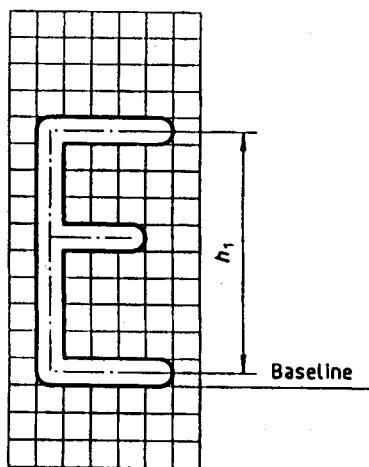


FIG. 7.4

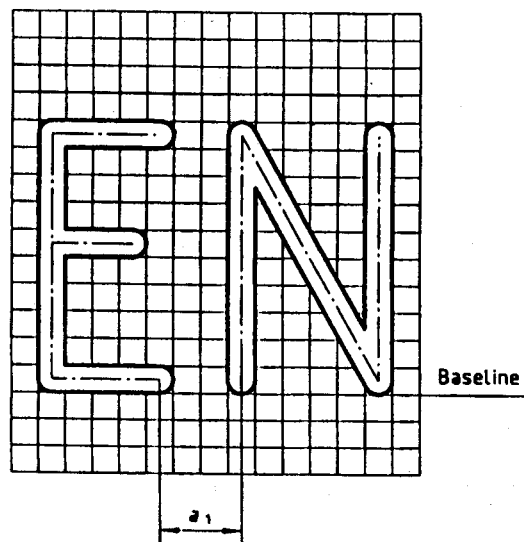


FIG. 7.5

The line widths shall be in accordance with IS 10714 (Part 20) and the same line width shall be used for both upper-case and lower-case letters.

7.4.4 Lettering Angle

The lettering may be vertical (upright) (see Fig. 7.1 to 7.5), or inclined (sloped) to the right at 75° from the horizontal (see Fig. 7.6).

7.4.5 Types of Lettering

The types of lettering are as follows:

- Lettering type A, vertical (V)
- Lettering type A, sloped (S)

Dimensions specified in Table 7.1

- Lettering type B, vertical (V) (preferred application)
- Lettering type B, sloped (S)

Dimensions specified in Table 7.2

- Lettering type CA, vertical (V)
- Lettering type CA, sloped (S)
- Lettering type CB, vertical (V) (preferred application)
- Lettering type CB, sloped (S)

See IS 9609 (Part 6) (for application of numerically controlled draughting via CAD)

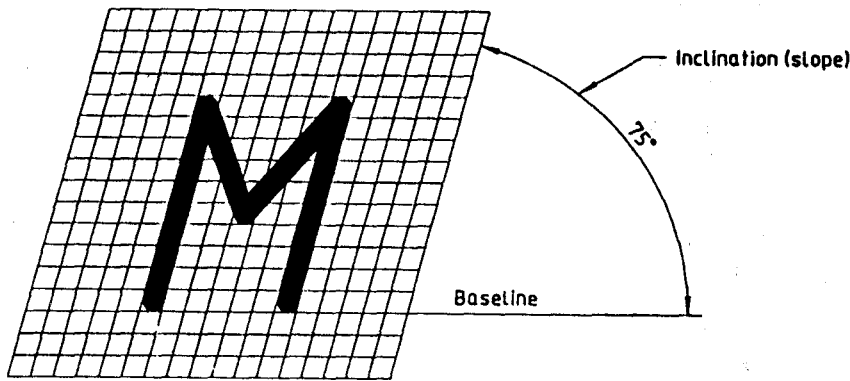


FIG. 7.6

Table 7.1 Dimensioning of Lettering Type A (Clauses 7.4.1, 7.4.2, 7.4.4 and 7.4.5)

All dimensions in millimetres.

Characteristic	Multiple of <i>h</i>	Dimensions								
Lettering height	<i>h</i> (14/14) <i>h</i>	1.8	2.5	3.5	5	7	10	14	20	
Height of lower-case letters (<i>x</i> -height)	<i>c</i> ₁ (10/14) <i>h</i>	1.3	1.8	2.5	3.5	5	7	10	14	
Tail of lower-case letters	<i>c</i> ₂ (4/14) <i>h</i>	0.52	0.72	1	1.4	2	2.8	4	5.6	
Stem of lower-case letters	<i>c</i> ₃ (4/14) <i>h</i>	0.52	0.72	1	1.4	2	2.8	4	5.6	
Area of diacritical marks (upper-case letters)	<i>f</i> (5/14) <i>h</i>	0.65	0.9	1.25	1.75	2.5	3.5	5	7	
Spacing between characters	<i>a</i> (2/14) <i>h</i>	0.26	0.36	0.5	0.7	1	1.4	2	2.8	
Minimum spacing between baselines ¹⁾	<i>b</i> ₁ (25/14) <i>h</i>	3.25	4.5	6.25	8.75	12.5	17.5	25	35	
Minimum spacing between baselines ²⁾	<i>b</i> ₂ (21/14) <i>h</i>	2.73	3.78	5.25	7.35	10.5	14.7	21	29.4	
Minimum spacing between baselines ³⁾	<i>b</i> ₃ (17/14) <i>h</i>	2.21	3.06	4.25	5.95	8.5	11.9	17	23.8	
Spacing between words	<i>e</i> (6/14) <i>h</i>	0.78	1.08	1.5	2.1	3	4.2	6	8.4	
Line width	<i>d</i> (1/14) <i>h</i>	0.13 ⁴⁾	0.18 ⁴⁾	0.25	0.35 ⁴⁾	0.5	0.7 ⁴⁾	1	1.4 ⁴⁾	

¹⁾ Lettering style: Upper-case and lower-case letters with diacritical marks (see Fig. 7.1).

²⁾ Lettering style: Upper-case and lower-case letters without diacritical marks (see Fig. 7.2).

³⁾ Lettering style: Upper-case letters only (see Fig. 7.3).

⁴⁾ Rounded values: The values of the dimensions *c*₁ through *e* are calculated from the rounded values of *d*.

Table 7.2 Dimensioning of Lettering Type B
(Clauses 7.4.1, 7.4.2, 7.4.4 and 7.4.5)

All dimensions in millimetres.

Characteristic		Multiple of h	Dimensions							
Lettering height	h	$(10/10)h$	1.8	2.5	3.5	5	7	10	14	20
Height of lower-case letters (x -height)	c_1	$(7/10)h$	1.26	1.75	2.5 ⁴⁾	3.5	5 ⁴⁾	7	10 ⁴⁾	14
Tail of lower-case letters	c_2	$(3/10)h$	0.54	0.75	1.05	1.5	2.1	3	4.2	6
Stem of lower-case letters	c_3	$(3/10)h$	0.54	0.75	1.05	1.5	2.1	3	4.2	6
Area of diacritical marks (upper-case letters)	f	$(4/10)h$	0.72	1	1.4	2	2.8	4	5.6	8
Spacing between characters	a	$(2/10)h$	0.36	0.5	0.7	1	1.4	2	2.8	4
Minimum spacing between baselines ¹⁾	b_1	$(19/10)h$	3.42	4.75	6.65	9.5	13.3	19	26.6	38
Minimum spacing between baselines ²⁾	b_2	$(15/10)h$	2.7	3.75	5.25	7.5	10.5	15	21	30
Minimum spacing between baselines ³⁾	b_3	$(13/10)h$	2.34	3.25	4.55	6.5	9.1	13	18.2	26
Spacing between words	e	$(6/10)h$	1.08	1.5	2.1	3	4.2	6	8.4	12
Line width	d	$(1/10)h$	0.18	0.25	0.35	0.5	0.7	1	1.4	2

¹⁾ Lettering style: Upper-case and lower-case letters with diacritical marks (see Fig. 7.1).

²⁾ Lettering style: Upper-case and lower-case letters without diacritical marks (see Fig. 7.2).

³⁾ Lettering style: Upper-case letters only (see Fig. 7.3).

⁴⁾ Rounded values.

7.4.6 Underlined and Overlined Texts or Text Fields

When a text or text field has to be underlined or overlined, it is recommended to interrupt the underlining or overlining line at all places where a lower-case letter has a tail (for example, Fig. 7.7) or where an upper-case or lower-case letter has a diacritical mark (for example, cedilla, tilde, umlaut; see Fig. 7.8). If this is not feasible, the space between baselines shall be extended.

7.5 Designation

7.5.1 The designation of lettering types A and B shall comprise the following elements in the given order:

- “Lettering”;
- “IS 9609”;
- The type of lettering (“A” or “B”);
- The inclination of lettering (“V” or “S”);

- The kind of alphabet (“L”, “G” or “C”); and
- The nominal size of the lettering, in mm.

Examples

A graphic character set of lettering Type B, vertical, Latin alphabet, of nominal size 5 mm, shall be designated as follows:

Lettering IS 9609 – BVL – 5

A graphic character set of lettering Type A, sloped, Greek alphabet, of nominal size 3.5 mm, shall be designated as follows:

Lettering IS 9609 – ASG – 3.5

A graphic character set of lettering Type B, sloped, Cyrillic alphabet, of nominal size 1.8 mm, shall be designated as follows:

Lettering IS 9609 – BSC – 1.8

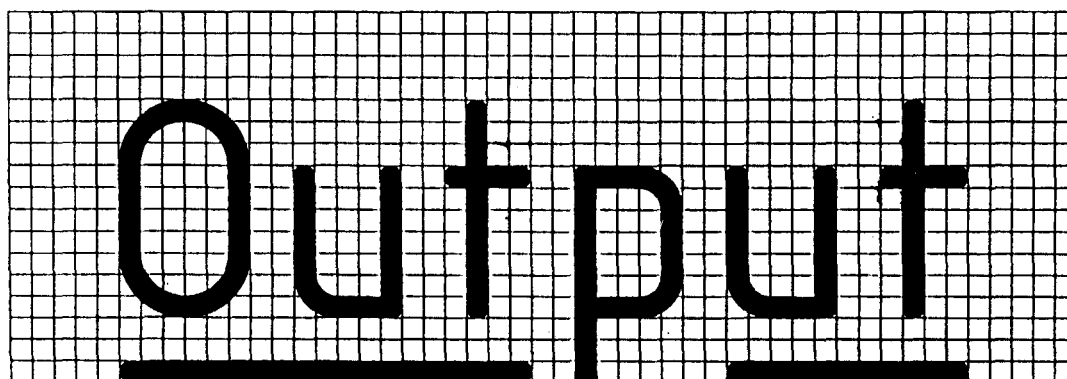


FIG. 7.7

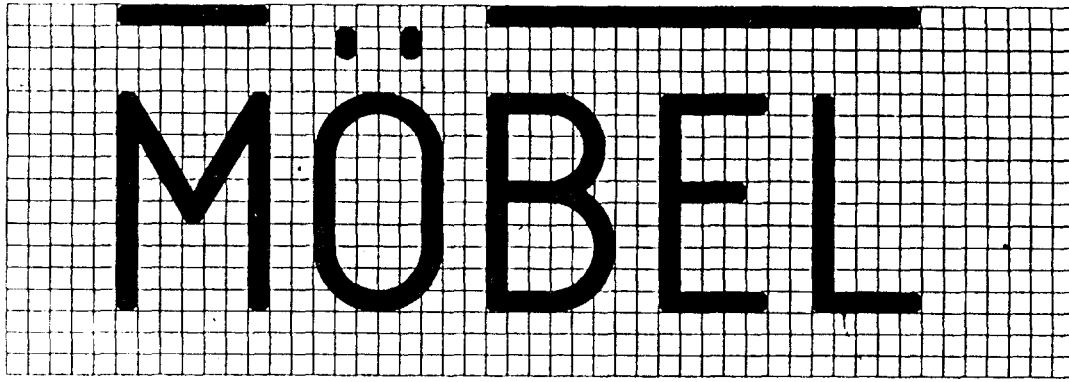


FIG. 7.8

7.5.2 The designation of lettering Types CA and CB shall comprise the following elements in the given order:

- a) "Lettering";
- b) "IS 9609";
- c) The type of lettering ("CA" or "CB");
- d) The spacing arrangement [tabular (T) or proportional (P)];
- e) The inclination of lettering ("V" or "S");
- f) The kind of alphabet ("L", "G" or "C"); and
- g) The nominal size of the lettering, in mm.

Examples

A graphic character set of lettering Type CB, in tabular spacing arrangement, sloped, Latin alphabet, of nominal size 2.5 mm, shall be designated as follows:

Lettering IS 9609 – CB TSL – 2.5

A graphic character set of lettering Type CA, in proportional spacing arrangement, vertical, Greek alphabet, of nominal size 3.5 mm, shall be designated as follows:

Lettering IS 9609 – CA PVG – 3.5

SECTION 8A PROJECTION METHODS — SYNOPSIS

[Based on IS 15021 (Part 1) : 2001/ISO 5456-1 : 1996]

8A.1 Scope

This section gives the various types of projection methods as well as their geometric relationships.

8A.2 Definitions

8A.2.1 Pictorial Representation

Parallel or central projection on a single projection plane giving a three-dimensional image of an object.

8A.2.2 True View

View of the features of an object that lie on a plane parallel to the projection plane; geometrically similar to the corresponding features of the object.

8A.2.3 Exploded View

Drawing of an assembly in pictorial representation in which all the components are drawn to the same scale and correctly orientated relative to each other, but are separated from each other in their correct sequence along common axes.

NOTE — This term should not be confused with representations where a covering layer is removed in order to show inner portions like those presented in section (cut-away view).

8A.2.4 Principal View

View of an object showing the important features, which may be chosen from the point of view of design, assembly, sales, service or maintenance.

8A.3 Survey of Projection Methods

Projection methods are defined by:

- the type of projectors, which may be either parallel or convergent;

- the position of the projection plane in relation to the projectors, either orthogonal or oblique;
- the position of the object (its main features), which may be either parallel/orthogonal or oblique to the projection plane

A survey of the various possibilities and their relationships is given in Table 8A.1.

8A.4 Geometrical Orientation

Geometrical orientation in space is given by coordinate axes and coordinate planes in accordance with the arrangement given by the right-hand rule.

8A.4.1 Coordinate Axes

Coordinate axes are imaginary lines in space which intersect at right angles to each other at the origin.

There are three coordinate axes: X, Y and Z (*see* Fig. 8A.1), to be designated by capital letters.

8A.4.2 Coordinate Planes

Three imaginary planes in space which intersect each other at right angles. Each of the three coordinate planes is defined by two coordinate axes and includes the origin. They are designated by capital letters XY, YZ and XZ (*see* Fig. 8A.2).

NOTE — Coordinate planes and projection planes are not always the same, therefore, if necessary, appropriate indication (designation) should be shown on the drawing.

8A.5 Invariables

Depending on the projection method chosen, certain features of the object are represented in true view as follows.

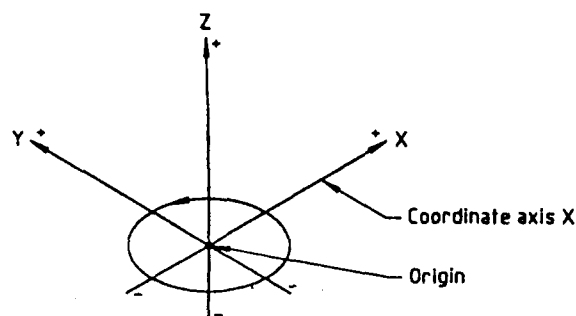


FIG. 8A.1

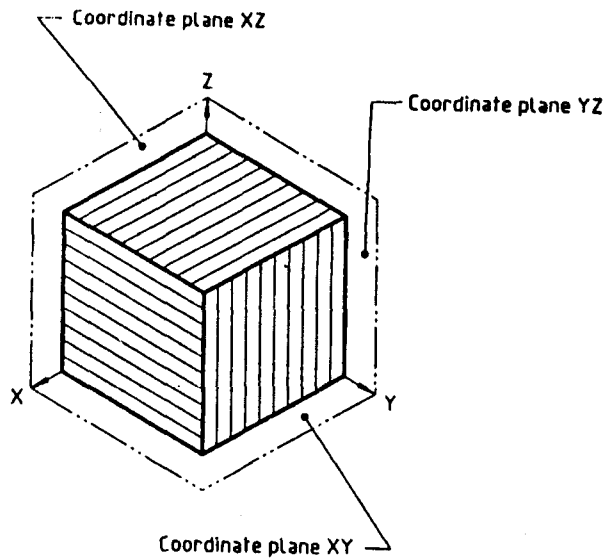


FIG. 8A.2

8A.5.1 The central projection invariable is :

- the size of angles in planes which are parallel to the projection plane; therefore the projection plane figures lying in planes parallel to the projection plane are similar.

8A.5.2 Oblique projection invariables are:

- the parallelism of lines, unless they are parallel to the projection lines;
- the divisional ratio of lines;

- the size of angles, length of lines and all plane figures in planes parallel to the projection plane.

8A.5.3 Orthogonal projection invariables are:

- the parallelism of lines, unless they are parallel to the projection lines;
- the divisional ratio of lines;
- the size of angles, length of lines and all plane figures in planes parallel to the projection plane;
- right angles, if one side of the right angle in the object is parallel to the projection plane.

Table 8A.1 Projection Systems
(Clause 8A.3)

Projection Centre	Position of Projection Plane to Projectors	Main Features of the Object in Relation to Projection Plane	Number of Projection Planes	Type of View	Type of Projection
Infinite (parallel projectors)	Orthogonal	Parallel/Orthogonal	One or more	Two-dimensional	Orthogonal [IS 15021 (Part 2)]
		Oblique	One	Three-dimensional	Axonometric [IS 15021 (Part 3)]
	Oblique	Parallel/Orthogonal	One	Three-dimensional	
		Oblique	One	Three-dimensional	

SECTION 8B PROJECTION METHODS — ORTHOGRAPHIC REPRESENTATIONS

[Based on IS 15021 (Part 2) : 2001/ISO 5456-2 : 1996]

8B.1 Scope

This section specifies basic rules for the application of orthographic representation to all types of technical drawings.

8B.2 General Principles

8B.2.1 General

Orthographic representation is obtained by means of parallel orthogonal projections and results in flat, two-dimensional views systematically positioned relative to each other. To show an object completely, the six views in the directions *a*, *b*, *c*, *d*, *e* and *f* may be necessary, in order of priority (see Fig. 8B.1 and Table 8B.1).

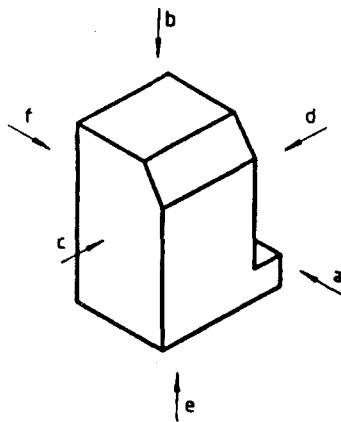


FIG. 8B.1

8B.2.2 Designation of Views

See Table 8B.1.

Table 8B.1 Designation of Views
(Clauses 8B.2.1 and 8B.2.2)

Direction of observation		Designation of View
View in Direction	View from	
<i>a</i>	the front	<i>A</i>
<i>b</i>	above	<i>B (E)</i> ¹⁾
<i>c</i>	the left	<i>C</i>
<i>d</i>	the right	<i>D</i>
<i>e</i>	below	<i>E</i>
<i>f</i>	the rear	<i>F</i>

¹⁾ See 8B.3.4.

The most informative view of the object to be represented is normally chosen as the principal view (front view). This is view *A* according to the direction of viewing *a* (see Fig. 8.1 and Table 8.1), generally showing the object in the functioning or manufacturing or mounting position. The position of other views relative to the principal view in the drawing depends on the projection method chosen (first angle, third angle, reference arrows). In practice, not all six views (*A* to *F*) are needed. When views (cuts or sections) other than the principal view are necessary, these shall be selected in order to:

- limit the number of views, cuts and sections to the minimum necessary and sufficient to fully represent the object without ambiguity;
- avoid unnecessary repetition of detail.

8B.3 Methods of Representation

8B.3.1 First Angle Projection

The first angle projection method is an orthographic representation in which the object to be represented (see Fig. 8B.1) appears between the observer and the coordinate planes on which the object is orthogonally projected (see Fig. 8B.2).

The positions of the various views relative to the principal (front) view *A* are determined by rotating their projection planes around lines coinciding with or parallel to the coordinate axes on the coordinate plane (drawing surface) on which the front view *A* is projected (see Fig. 8B.2).

Therefore, in the drawing, with reference to the principal view *A*, the other views are arranged as follows (see Fig. 8B.3):

- View *B*: The view from above is placed underneath;
- View *E*: The view from below is placed above;
- View *C*: The view from left is placed on the right;
- View *D*: The view from the right is placed on the left;
- View *F*: The view from the rear is placed on the right or on the left, as convenient.

The identifying graphical symbol of this method is shown in Fig. 8B.4.

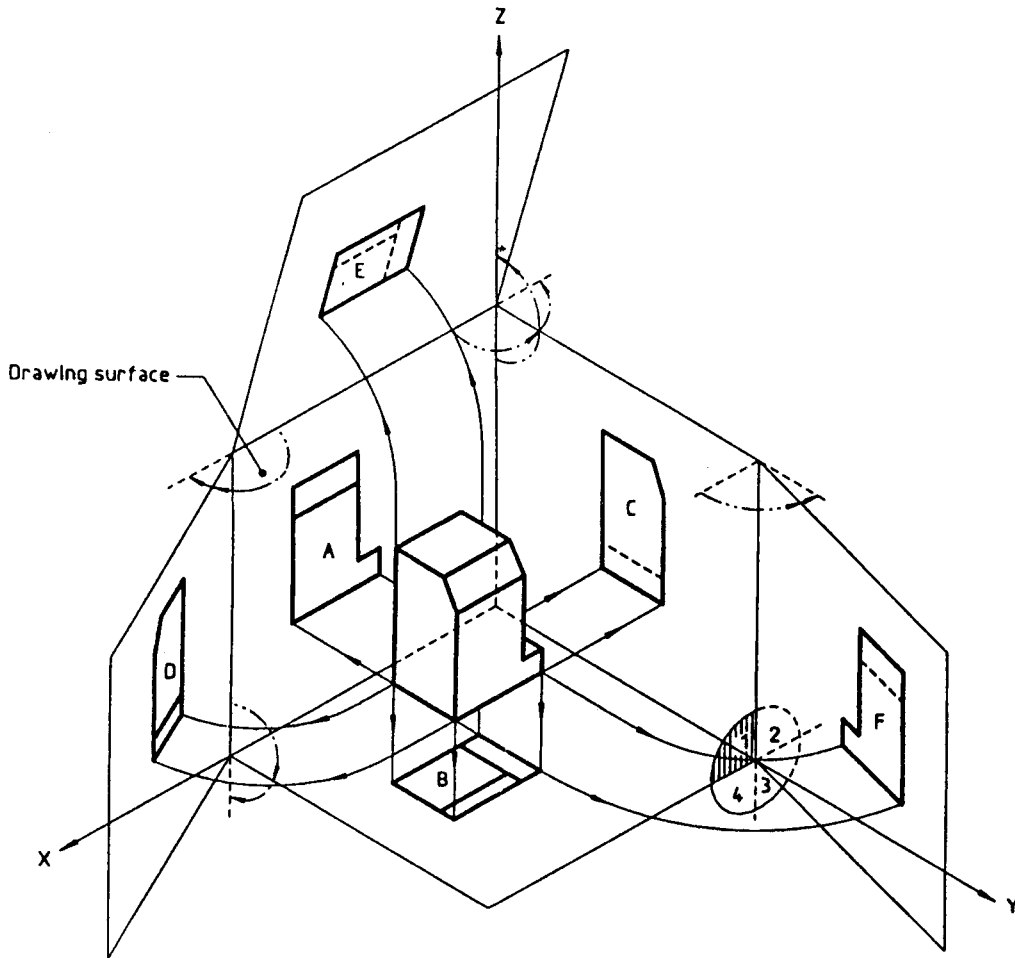


FIG. 8B.2

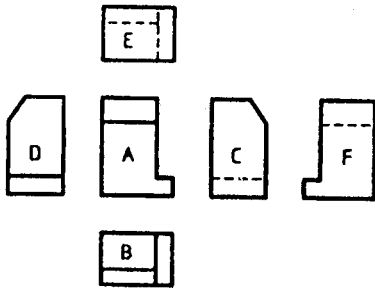


FIG. 8B.3



FIG. 8B.4

8B.3.2 Third Angle Projection

The third angle projection method is an orthographic representation in which the object to be represented (see Fig. 8B.1), as seen by the observer, appears behind

the coordinate planes on which the object is orthogonally projected (see Fig. 8B.5). On each projection plane, the object is represented as if seen orthogonally from infinite distance with transparent projection planes.

The position of the various views relative to the principal (front) view A are determined by rotating their projection planes around lines coinciding with or parallel to the coordinate axes on the coordinate plane (drawing surface) on which the front view A is projected (see Fig. 8B.5).

Therefore, in the drawing, with reference to the principal view A, the other views are arranged as follows (see Fig. 8B.6):

- View B: The view from above is placed above;
- View E: The view from below is placed underneath;
- View C: The view from left is placed on the left;
- View D: The view from the right is placed on the right;
- View F: The view from the rear may be placed on the left or on the right, as convenient.

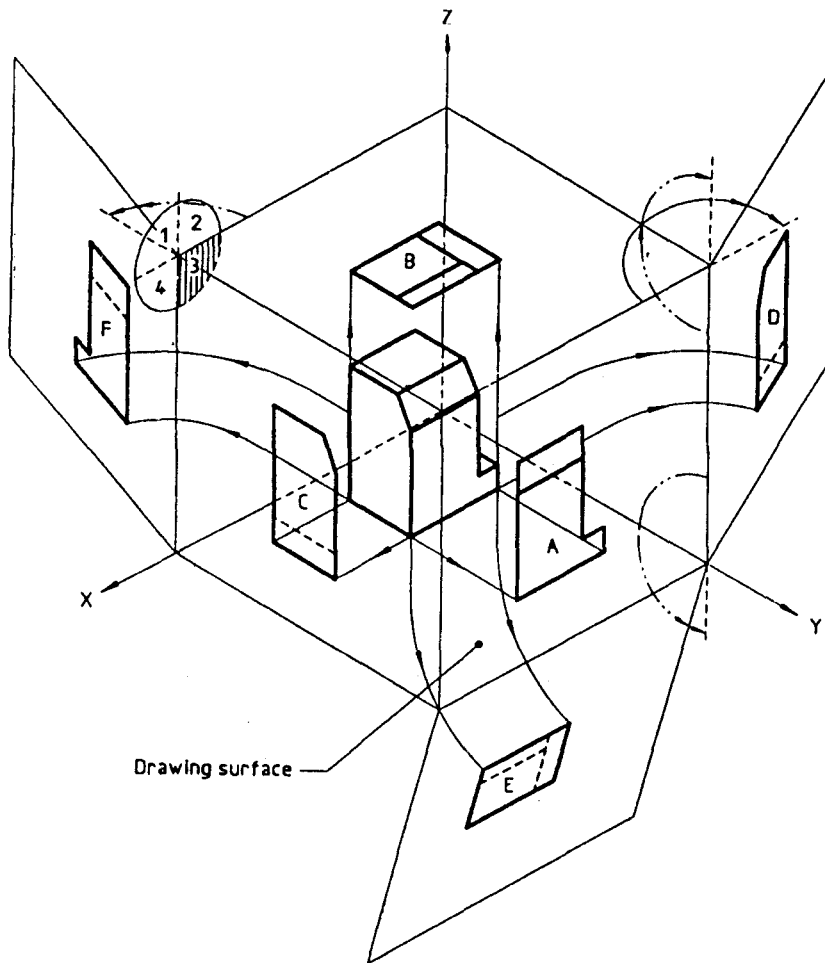


FIG. 8B.5

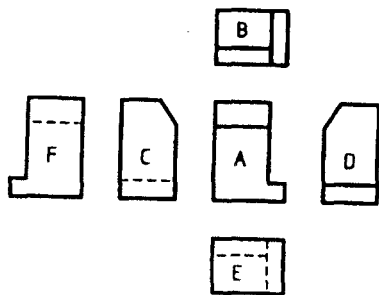


FIG. 8B.6

The identifying graphical symbol of this method is shown in Fig. 8B.7.

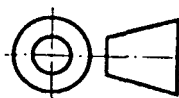


FIG. 8B.7

8B.3.3 Reference Arrows Layout

In those cases where it is advantageous to position the views not according to the strict pattern of the first or the third angle projection method, the use of the reference arrows method permits the various views to be freely positioned.

With the exception of the principal view, each view shall be identified by a letter in accordance with Fig. 8B.1. A lower-case letter indicates in the principal view the direction of observation of the other views, which are identified by the corresponding capital letter placed immediately above the view and on the left.

The identified views may be located irrespective of the principal view (*see* Fig. 8B.8). Whatever the direction of observation, the capital letters [*see* IS 9609 (Part 1)] identifying the views shall always be positioned to be read from the normal direction of viewing of the drawing.

No graphical symbol for the indication of this method is needed on the drawing.

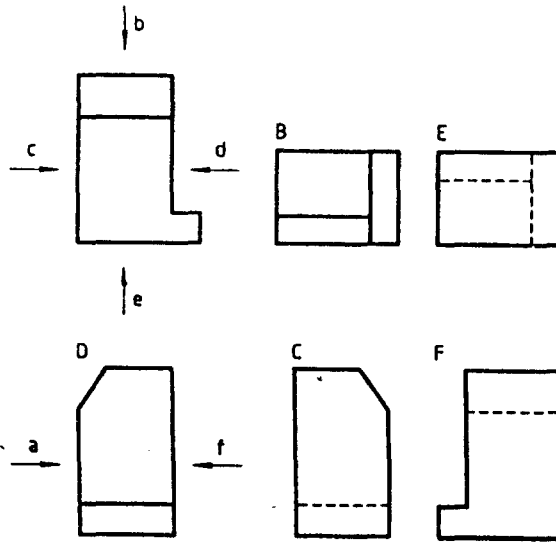


FIG. 8B.8

8B.3.4 Mirrored Orthographic Representation

Mirrored orthographic representation¹⁾ is an orthographic representation in which the object to be represented (see Fig. 8B.1) is a reproduction of the image in a mirror (face up) which is positioned parallel to the horizontal planes of this object (see Fig. 8B.9).

The view resulting from a mirrored orthographic representation may be indicated by using the capital letter for the designation of views (that is 'E', see 8B.2.2).

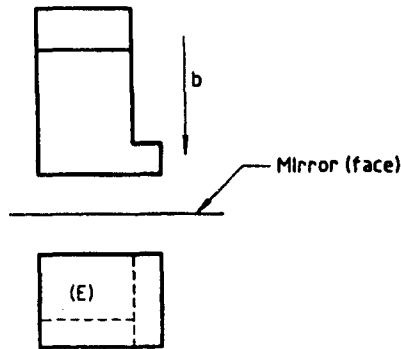


FIG. 8B.9

The identifying graphical symbol of this method is shown in Fig. 8B.10.

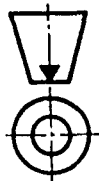


FIG. 8B.10

¹⁾ This method is preferably used in construction drawings.

8B.3.5 Layout of Views Using Reference Arrows

In those cases where it is an advantage to position the views not according to the strict pattern of the first or the third angle projection methods, the use of reference arrows permits the various views to be freely positioned.

With the exception of the principal view, each view shall be identified by a capital letter which is repeated near the arrow needed to indicate the direction of viewing for the relevant view.

The designated views may be located irrespective of the principal view. The capital letters identifying the referenced views shall be placed either immediately below or above the relevant views. In any one drawing, the references shall be placed in the same way. No other indication is necessary (see Fig. 8B.11).

8B.3.6 Indication of Method

Where one of the methods specified earlier is being used, the said method must be indicated on the drawing by means of its distinguishing symbol as shown in Fig. 8B.4 or Fig. 8B.7.

The symbol shall be placed in a space provided for the purpose in the title block of the drawing.

For the layout of views using reference arrows specified in 8B.3.5, no distinguishing symbol is required.

8B.3.7 Choice of Views

8B.3.7.1 The most informative view of an object shall be used as the front or principal view. Generally, this view shows the part in the functioning position. Parts which can be used in any position should preferably

be drawn in the main position of manufacturing or mounting.

8B.3.7.2 When other views (including sections) are needed, these shall be selected according to the following principles:

- to limit the number of views and sections to the minimum necessary and sufficient to fully delineate the object without ambiguity,
- to avoid the need for hidden outlines and edges, and
- to avoid unnecessary repetition of detail.

8B.3.8 Special Views

8B.3.8.1 If a direction of viewing different from those shown in **8B.2.2** is necessary, or if a view cannot be placed in its correct position using the methods shown in **8B.3.1** and **8B.3.2**, reference arrows as indicated in **8B.3.5** shall be used for the relevant view (see Fig. 8B.12 and 8B.13).

8B.3.8.2 Whatever the direction of viewing, the capital letters referencing the views shall always be positioned normal to the direction of reading.

8B.3.9 Partial Views

Partial views may be used where complete views would not improve the information to be given. The partial view shall be cut off by a continuous narrow freehand line (01.1.18) or continuous narrow lines with zigzags (01.1.19) (see Fig. 8B.12).

8B.3.10 Local Views

8B.3.10.1 Provided that the presentation is unambiguous, it is permitted to give a local view instead of a complete view for symmetrical items. The local view should be drawn in third angle projection, regardless of the arrangement used for the general execution of the drawing.

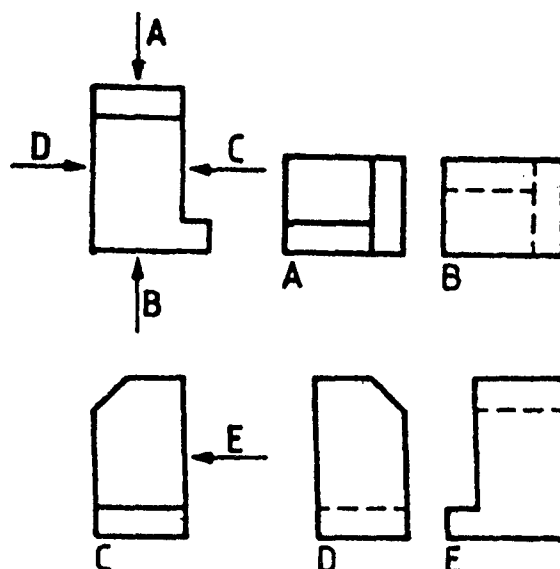


FIG. 8B.11

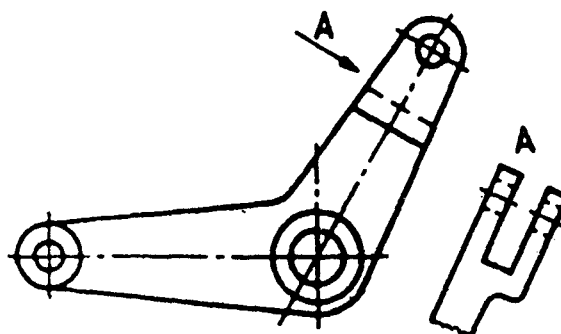


FIG. 8B.12

8B.3.10.2 Local views shall be drawn with continuous wide lines (01.1.1), and shall be connected to the principal view by a centre line (04.1.2). Examples of local views are shown in Fig. 10.27 to 10.30.

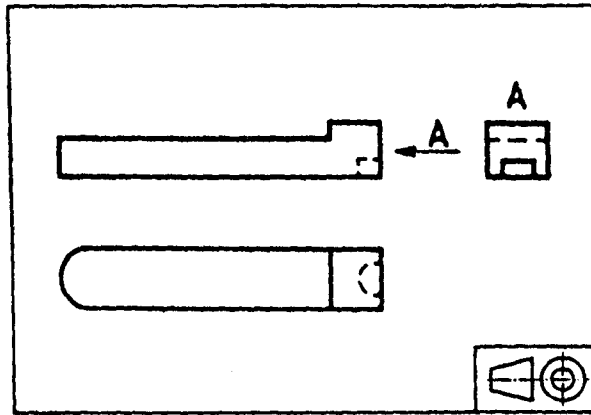


FIG. 8B.13

SECTION 8C PROJECTION METHODS — AXONOMETRIC REPRESENTATIONS

[Based on IS 15021 (Part 3) : 2001/ISO 5456-3 : 1996]

8C.1 Scope

This section specifies basic rules for the application of the recommended axonometric representations for all types of technical drawings.

8C.2 General

The general principles of presentation given in Section 8B shall be followed.

8C.2.1 Position of the Coordinate System

The position of the coordinate axes shall be chosen, by convention, so that one of the coordinate axes (the Z-axis) is vertical.

8C.2.2 Position of the Object

The object to be represented is located with its principal faces, axes and edges parallel to the coordinate planes. The object shall be orientated to show the principal view and the other views that would preferably be chosen when representing the same object in orthogonal projections.

8C.2.3 Axes of Symmetry

Axes and traces of planes of symmetry of the object shall not be drawn unless necessary.

8C.2.4 Hidden Contours and Edges

Hidden contours and edges should preferably be omitted.

8C.2.5 Hatching

Hatching to indicate a cut or section shall be drawn preferably at an angle of 45° with respect to axes and contours of the cut or section (see Fig. 8C.1).

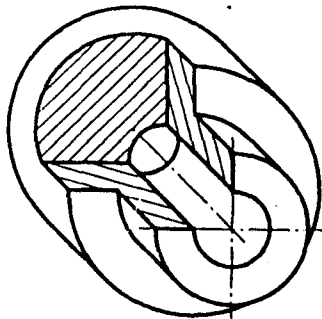


FIG. 8C.1

Hatching to indicate planes parallel to the coordinate planes shall be drawn parallel to the projected coordinate axis, as shown in Fig. 8C.2.

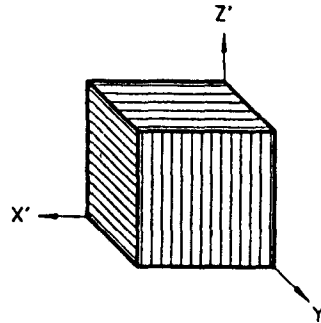


FIG. 8C.2

8C.2.6 Dimensioning

Dimensioning of axonometric representations is normally avoided. If, for special reasons, dimensioning is considered necessary, the same rules given for orthogonal projections (Sections 7 and 12) shall be used (see Fig. 8C.6 and 8C.12).

8C.3 Recommended Axonometries

Recommended axonometries for technical drawings are:

- isometric axonometry (see 8C.3.1);
- dimetric axonometry (see 8C.3.2); and
- oblique axonometry (see 8C.3.3).

Coordinate axes X , Y and Z are to be indicated by upper case letters. If other items (for example, dimensions) have to be indicated in a table or drawing, lower-case letters x , y and z shall be used for better differentiation.

8C.3.1 Isometric Axonometry

The isometric axonometry is the orthogonal axonometry in which the projection plane forms three equal angles with the three coordinate axes X , Y and Z ¹⁾.

Three unit length segments u_x , u_y and u_z on the three coordinate axes X , Y and Z , are respectively projected

¹⁾This gives a representation identical to that obtained by orthogonal projection of the principal view of a right hexahedron with all its faces equally inclined to the projection plane.

orthogonally on the projection plane in three equal segments $u_{x'}$, $u_{y'}$ and $u_{z'}$ on the projected X' , Y' and Z' axes whose lengths are:

$$u_{x'} = u_{y'} = u_{z'} = (2/3)^{1/2} = 0.816$$

The projection X' , Y' and Z' of the three coordinate axes X , Y and Z on the projection plane (drawing surface) is shown in Fig. 8C.3.

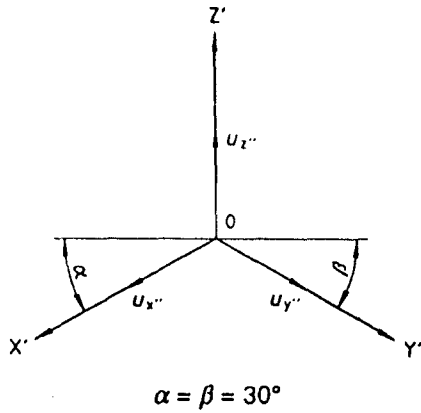


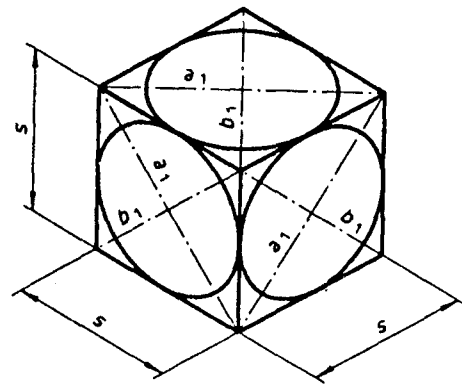
FIG. 8C.3

In drawing practice, the projected unit length segments on the X' , Y' and Z' axes are taken as $u_{x'} = u_{y'} = u_{z'} = 1$, which corresponds to a graphic representation of the object enlarged by a factor $(3/2)^{1/2} = 1.225$.

The isometric axonometry of a right hexahedron with circles inscribed on its faces is represented in Fig. 8C.4.

The isometric axonometry gives the same visual importance to all three faces of the right hexahedron, and is therefore convenient to draw on an equilateral-triangle grid (see Fig. 8C.5).

An example of dimensioning for isometric axonometry is given in Fig. 8C.6.



Length of the ellipse axes:

$$a_1 = \sqrt{\frac{3}{2}} s \approx 1.225s$$

$$b_1 = \sqrt{\frac{1}{2}} s \approx 0.71s$$

FIG. 8C.4

8C.3.2 Dimetric Axonometry

Dimetric axonometry is used when a view of the object to be represented is of main importance. The projection of the three coordinate axes is given in Fig. 8C.7. The ratio of the three scales is $u_{x'} : u_{y'} : u_{z'} = 1/2 : 1 : 1$.

The dimetric axonometry of a right hexahedron with circles inscribed in its faces is given in Fig. 8C.8.

8C.3.3 Oblique Axonometry

In oblique axonometry, the projection plane is parallel to one coordinate plane and to the main face of the object to be represented, whose projection remains in the same scale. Two of the projected coordinate axes are orthogonal. The direction of the third projected

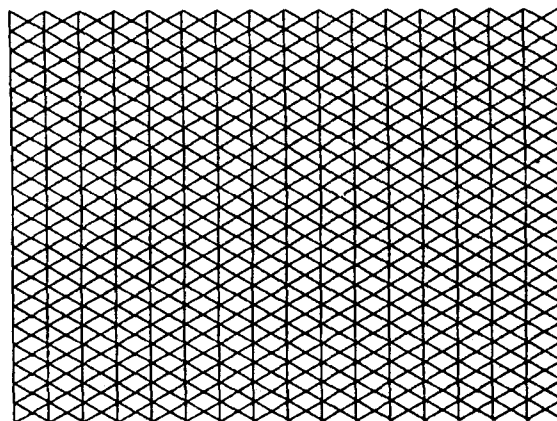


FIG. 8C.5

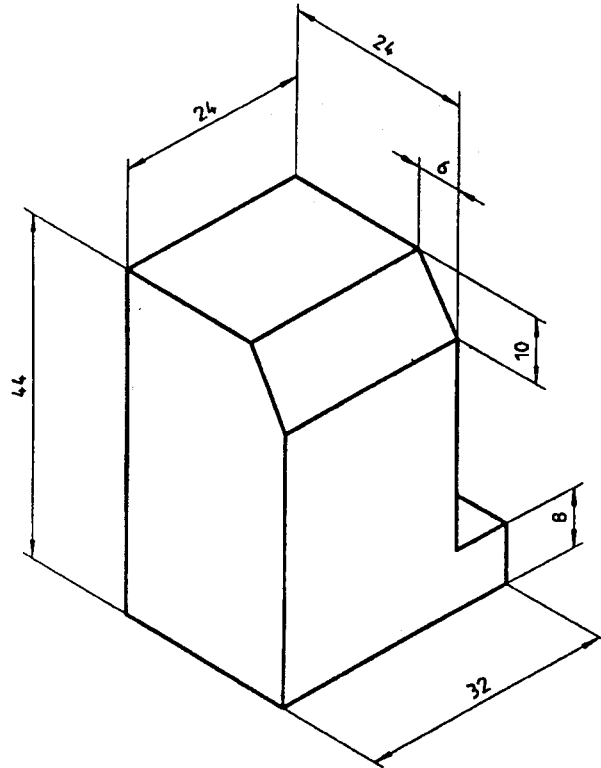


FIG. 8C.6

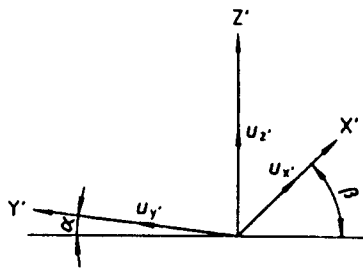
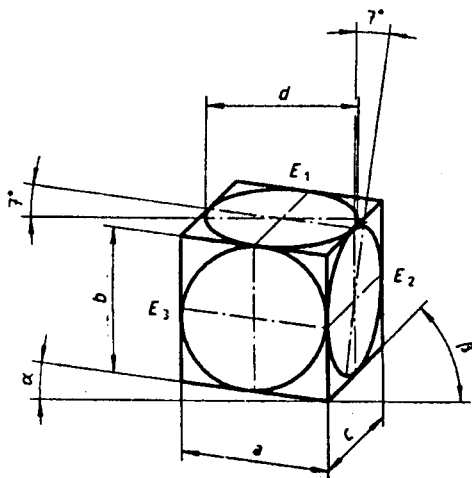


FIG. 8C.7

coordinate axis and its scale are arbitrary. Several types of oblique axonometry are used, because of their ease of drawing.

8C.3.3.1 Cavalier axonometry

In this type of oblique axonometry, the projection plane is normally vertical and the projection of the third coordinate axis is chosen by convention at 45° to the remaining projected orthogonal axes; the scales on the three projected axes are identical: $u_{x'} = u_{y'} = u_{z'} = 1$ (see Fig. 8C.9).



$a:b:c = 1:1:1/2$
 $\alpha = 7^\circ$
 $\beta = 42^\circ$

FIG. 8C.8

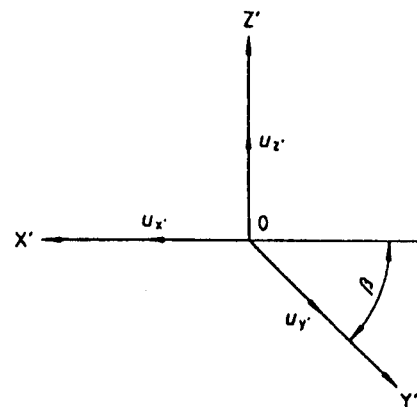


FIG. 8C.9

The four possible cavalier axonometries of a right hexahedron are shown in Fig. 8C.10.

Cavalier axonometry is very simple to draw and makes it possible to dimension the drawing, but heavily distorts the proportions along the third coordinate axis.

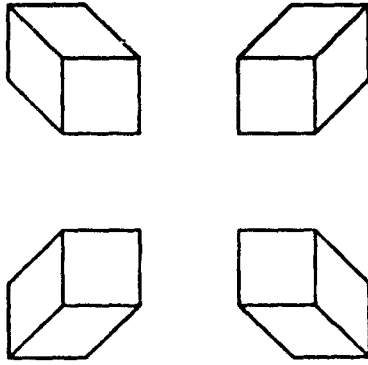


FIG. 8C.10

An example of dimensioning is given in Fig. 8C.12.

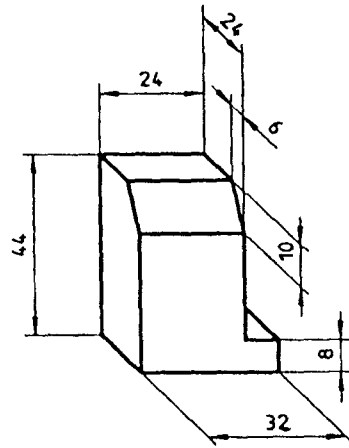
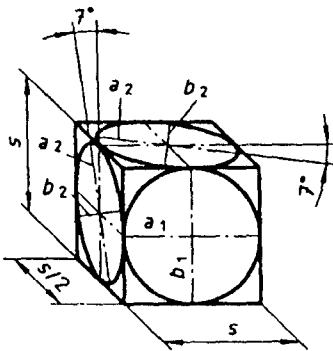


FIG. 8C.12

8C.3.3.2 Cabinet axonometry

Cabinet axonometry is similar to cavalier axonometry, except that on the third projected axis the scale is reduced by a factor of two. This provides a better proportion to the drawing.

A cabinet axonometric representation of a right hexahedron with circles inscribed in its faces is shown in Fig. 8C.11.



$$a_1 = b_1 = s$$

Length of the ellipse axes:

$$a_2 = 1.06s$$

$$b_2 = 0.33s$$

FIG. 8C.11

8C.3.3.3 Planometric axonometry

In planometric axonometry, the projection plane is parallel to the horizontal coordinate plane. Projections using angles ($\alpha = 0^\circ, 90^\circ$ or 180°) should be avoided so that all necessary information can be presented (see Fig. 8C.13).

8C.3.3.3.1 Normal planometric projection

Possible projections of coordinate axes whose scales can be chosen in the ratio 1 : 1 : 1 are shown in Fig. 8C.14.

A right hexahedron with its dimensioning is given in Fig. 8C.15.

This type of oblique axonometry is particularly suited for town planning drawings.

8C.3.3.3.2 Shortened planometric projection

Possible projections of the coordinate axes whose scales can be chosen in the ratio 1 : 1 : 2/3 are shown in Fig. 8C.14.

A right hexahedron with its dimensioning is given in Fig. 8C.16.

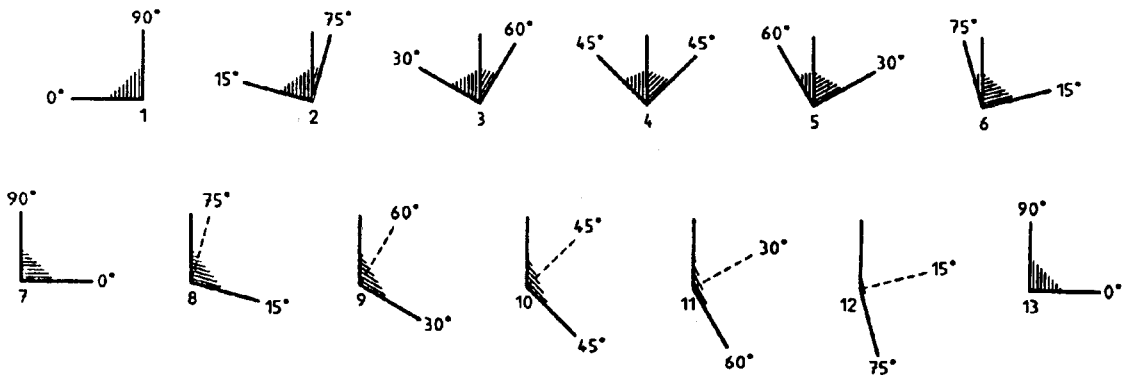
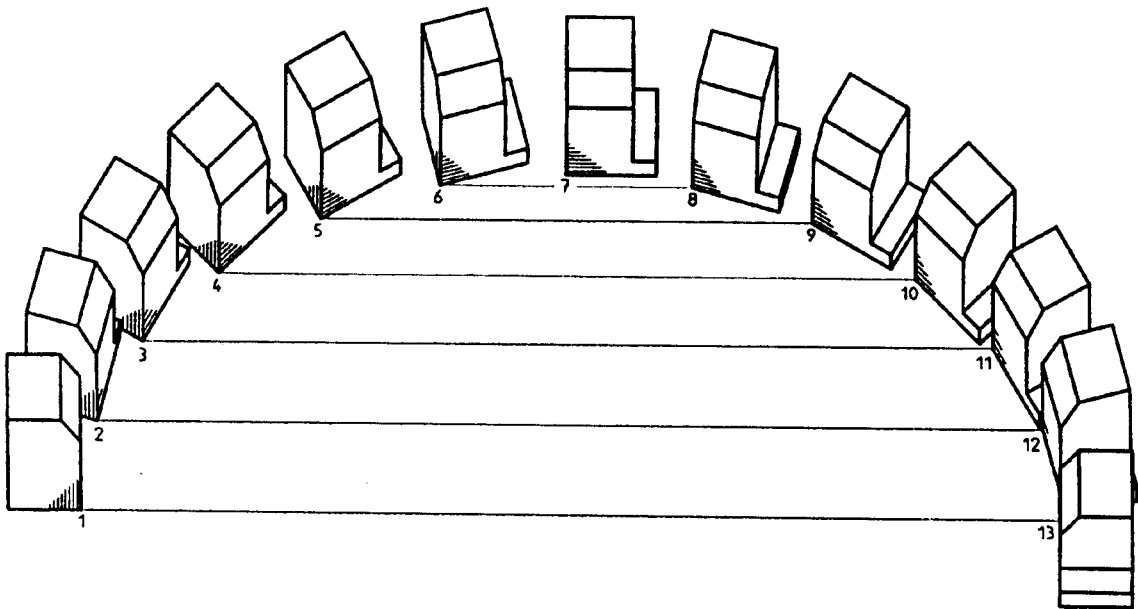
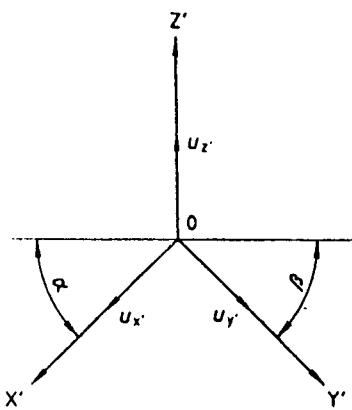


FIG. 8C.13



$\alpha = 0^\circ \text{ to } 180^\circ$
 $\beta = 90^\circ - \alpha$

FIG. 8C.14

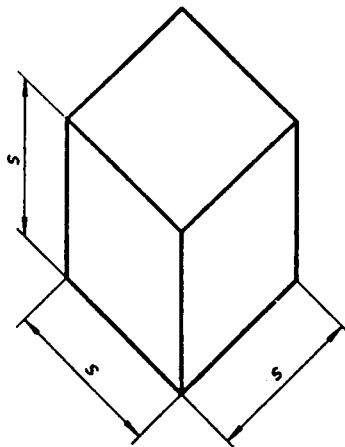


FIG. 8C.15

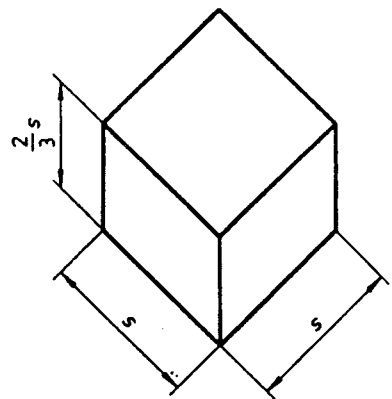


FIG. 8C.16

SECTION 8D PROJECTION METHODS — CENTRAL PROJECTION

[Based on IS 15021 (Part 4) : 2001/ISO 5456-4 : 1996]

8D.1 Scope

This section specifies basic rules for the development and application of central projection in technical drawings.

8D.2 Definitions

8D.2.1 Alignment Line

Line parallel to a given line passing through the projection centre. Its intersection with the projection plane gives the vanishing point of all lines parallel to the given line.

8D.2.2 Height of Projection

Vertical distance of the projection centre from the basic plane.

8D.2.3 Horizontal Distance

Distance between the projection centre and the projection plane.

8D.2.4 Projection Angle

Angle formed by the projection plane and the horizon plane.

8D.2.5 Scale Point

Vanishing point of the horizontal direction orthogonal to that bisecting the angle formed by the horizon line and the alignment line of the given horizontal line, and allowing the true length of the projection of the given line to be determined.

8D.2.6 Station of Observation

Orthogonal projection of the projection centre onto the basic plane.

8D.3 Symbols

Letter symbols for terms used in central projection are given in Table 8D.1 and illustrated in Fig. 8D.1 and 8D.2, as well as in the figures mentioned in Table 8D.1.

8D.4 Central Projection Methods

The mode of the central projection depends on the position of the object to be represented with respect to the projection plane.

For possible positions and applicable projection methods, see 8D.4.1 to 8D.4.4.

Table 8D.1 Letter Symbols
(Clause 8D.3)

Clause No.	Term	Letter Symbol	Figure
1)	Projection plane	<i>T</i>	8D.1
1)	Basic plane	<i>G</i>	8D.1
1)	Basic line	<i>X</i>	8D.1
8D.2.4	Projection angle	β	8D.5
1)	Horizon plane	<i>HT</i>	8D.1
1)	Horizon line	<i>h</i>	8D.1
8D.2.1	Alignment line	<i>Vl</i>	8D.4
1)	Main point	<i>C</i>	8D.1
1)	Vanishing point	<i>V</i>	8D.4
1)	Main projector	<i>pL</i>	8D.1
1)	Projection centre	<i>O</i>	8D.1
8D.2.2	Height of projection	<i>H</i>	8D.1
8D.2.3	Horizontal distance	<i>d</i>	8D.1
1)	Vision cone	<i>K</i>	8D.2
1)	Circle of vision	<i>Ks</i>	8D.3
1)	Vision angle	α	8D.2
1)	Projector	<i>Pl</i>	8D.3
1)	Distance point	<i>DP</i>	8D.13
8D.2.5	Scale point	<i>MP</i>	8D.14
8D.2.6	Station of observation	<i>Sp</i>	8D.1

¹⁾ Terms already defined in IS 8930 (Part 2).

8D.4.1 One-point Method

A one-point projection method is a central projection of an object having its principal face parallel to the projection plane (special position). All parallel outlines and edges of the object which are parallel to the projection plane retain their direction in this representation (horizontal lines remain horizontal and vertical lines remain vertical). All lines perpendicular to the projection plane converge at the vanishing point, *V*, coinciding with the main point, *C* (see Fig. 8D.3 and 8D.6.2.1 and 8D.6.3).

8D.4.2 Two-point Method

A two-point projection method is a central projection of an object having its vertical outlines and edges parallel to the projection plane (particular position). All horizontal lines of a representation converge at multiple vanishing points V_1, V_2, V_3, \dots , on the horizon line (see Fig. 8D.4 and 8D.6.2.2 and 8D.6.4).

8D.4.3 Three-point Method

A three-point projection method is a central projection of an object having no outlines or edges parallel to the projection plane (any position). If the projection plane is inclined towards the projection centre, that is, $\beta > 90^\circ$, the vanishing point for vertical lines is

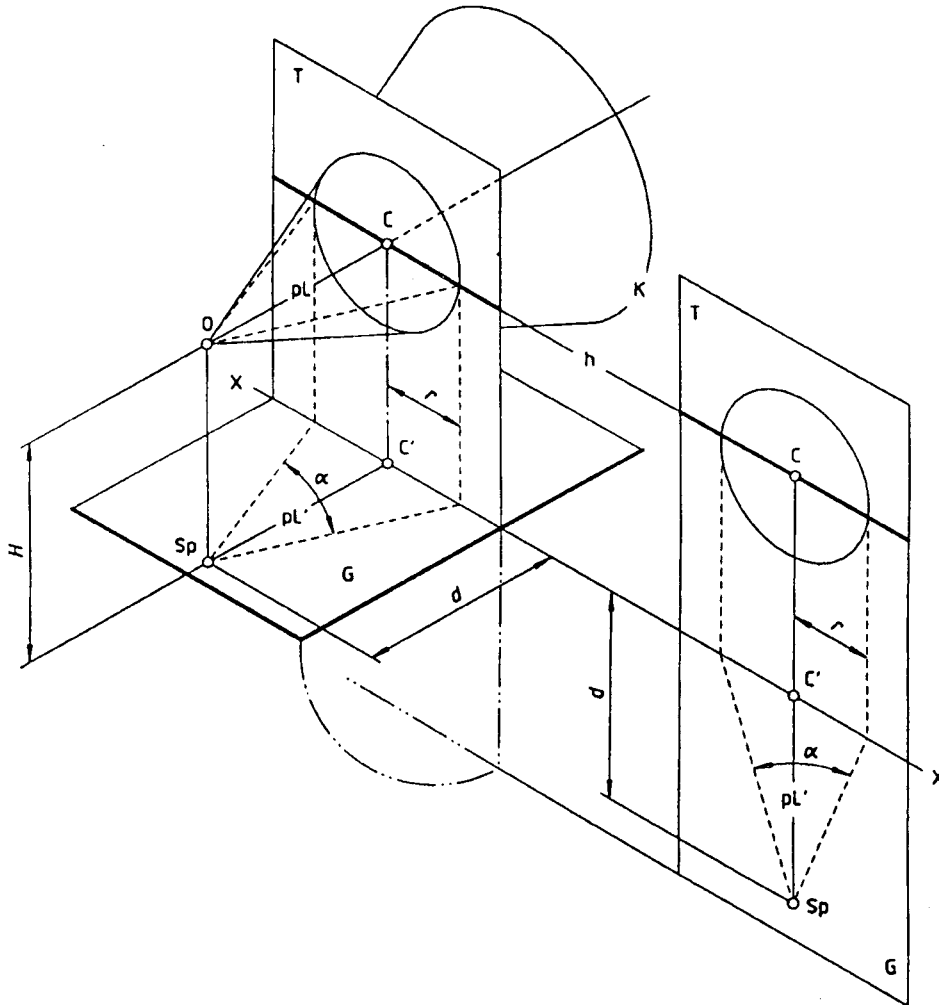


FIG. 8D.2 VISION CONE AND VISION ANGLE IN THE PROJECTION MODEL OF THE CENTRAL PROJECTION

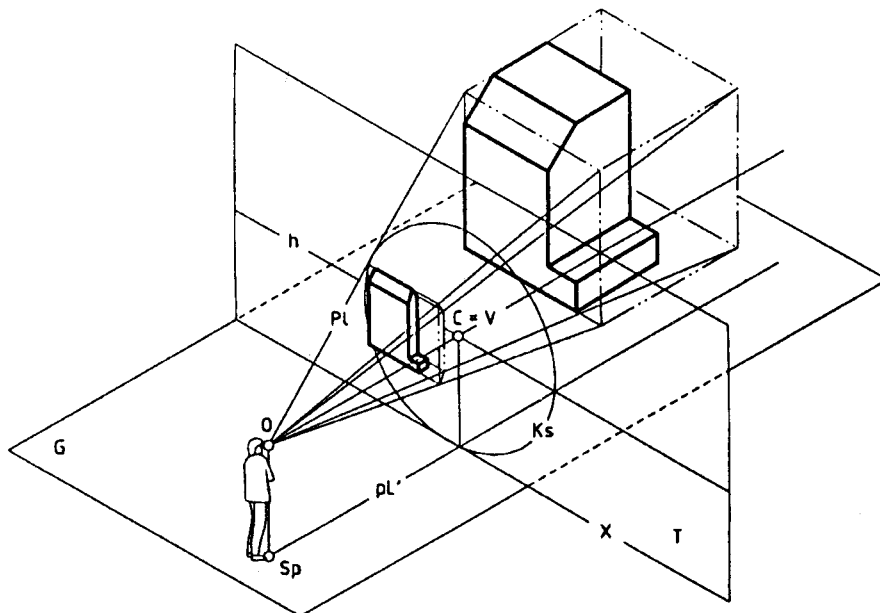


FIG. 8D.3 PROJECTION MODEL WITH VERTICAL PROJECTION PLANE AND AN OBJECT IN A SPECIAL POSITION WITH RESPECT TO THE PROJECTION PLANE

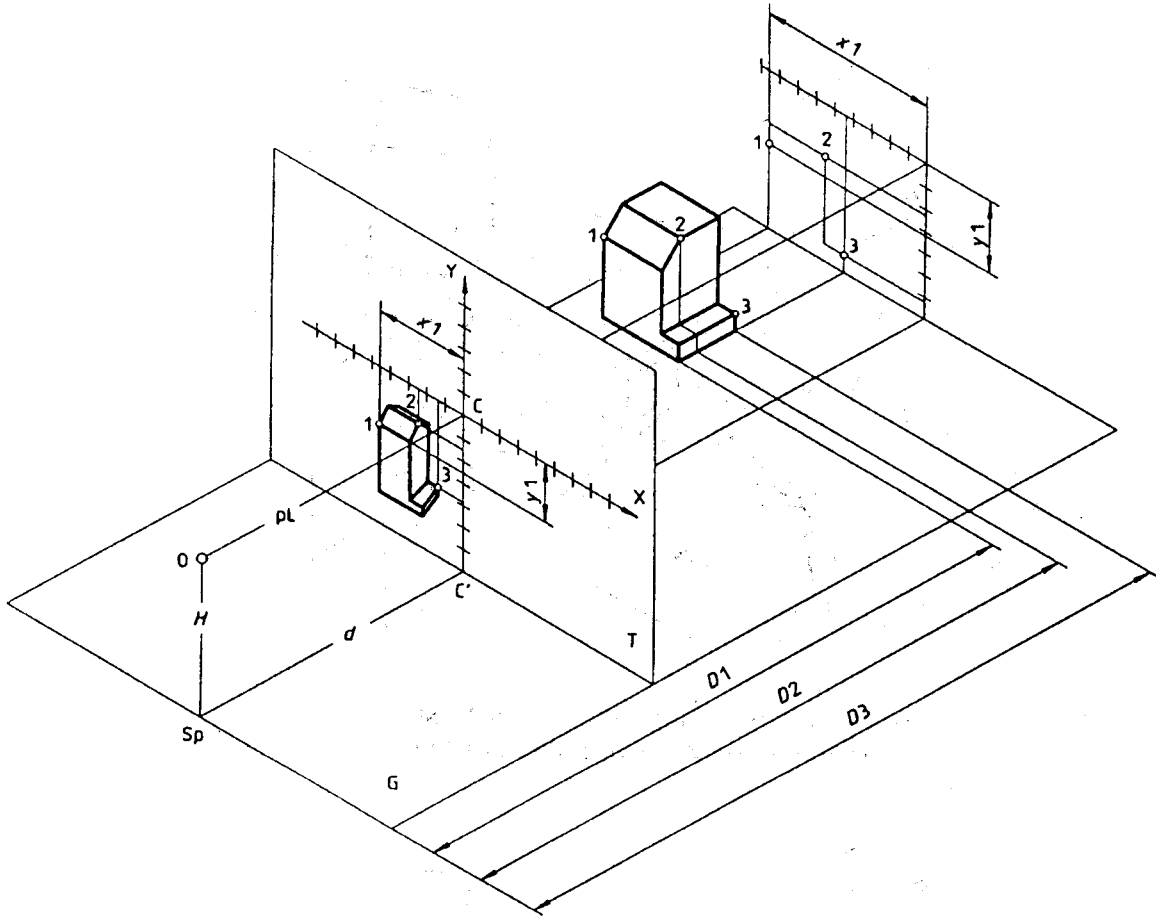


FIG. 8D.6 PROJECTION MODEL WITH VERTICAL PROJECTION PLANE AND AN OBJECT IN SPECIAL POSITION, SHOWING THE LENGTHS USED IN THE MATHEMATICAL FORMULA FOR CALCULATION OF THE PERSPECTIVE IMAGE

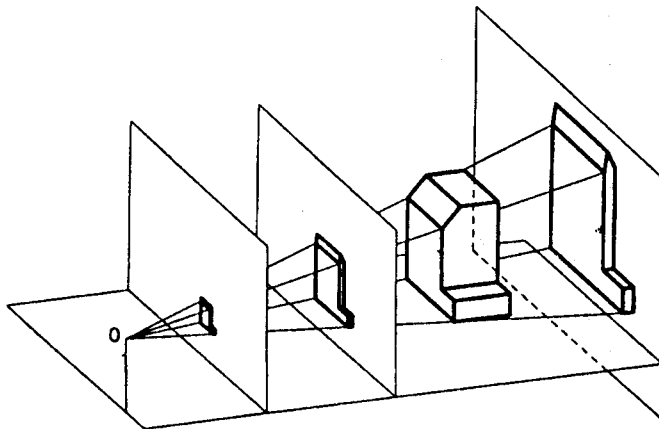


FIG. 8D.7 LOCATION OF PROJECTION PLANES

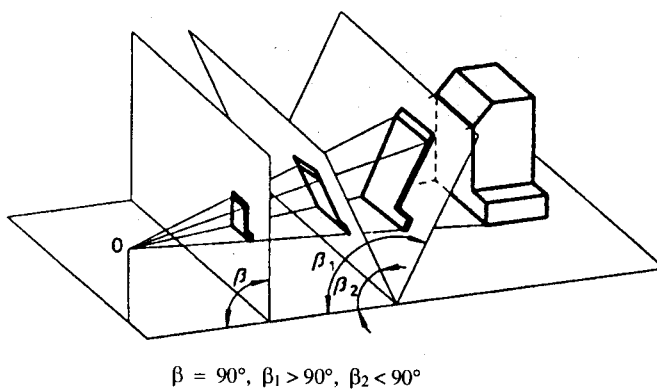


FIG. 8D.8 POSITION OF PROJECTION PLANES

8D.5.2 Circle of Vision and Vision Cone

To obtain a fully instructive image of an object without peripheral distortions on the projection plane, the object must be positioned within a vision cone having an aperture angle not greater than 60° .

Heavy peripheral distortions occur on images outside the circle of vision; the image does not appear fully instructive since length, width and height do not match the object's inherent proportions (see Fig. 8D.9).

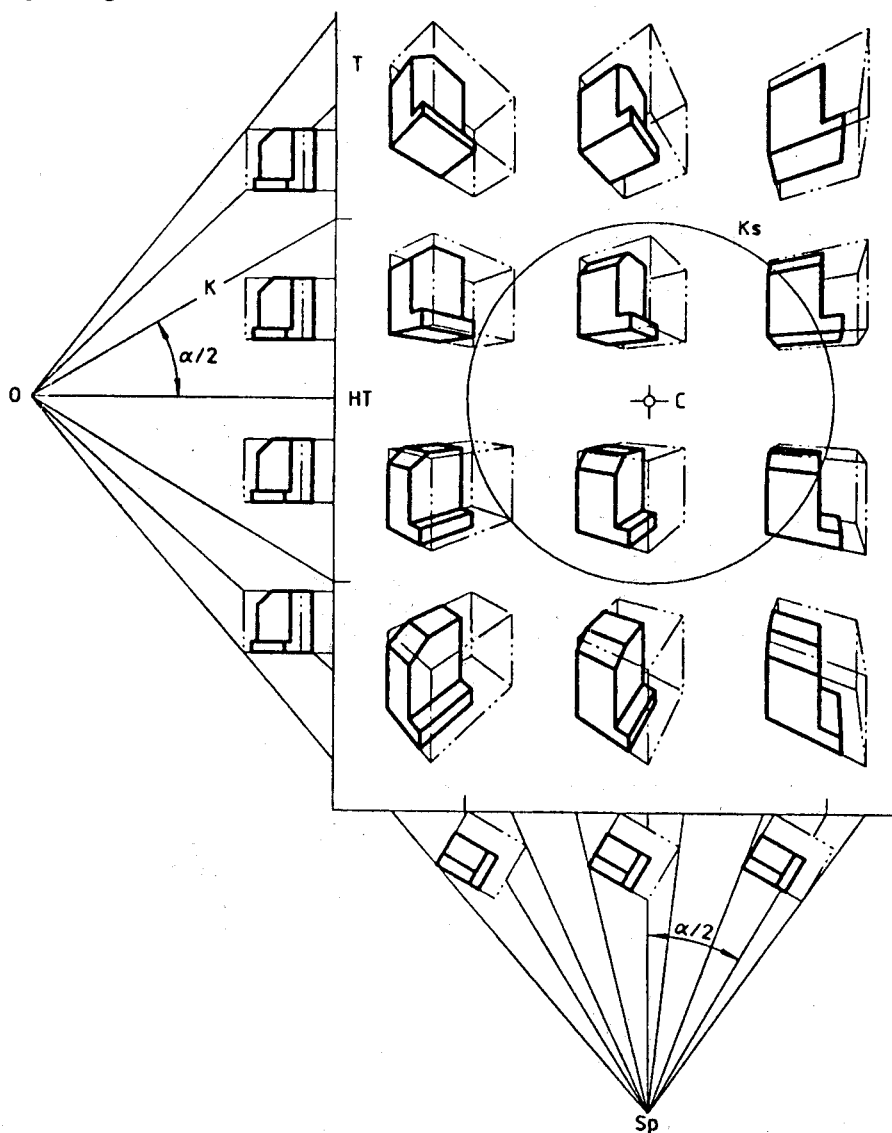


FIG. 8D.9 OBJECT, FRAMED IN A CUBE, WITHIN AND OUTSIDE THE CIRCLE OF VISION

An object can be depicted nearly undistorted if the projectors result in a bundle of rays inclined not more than 30° with respect to the main projector. At this aperture angle the vision cone provides only a small distortion on the projection plane.

The main projector should hit the object to be depicted in a part which is visually important, so that the object is contained within the minimum vision cone.

8D.5.3 Distance

Different relative distances influence the image size and its appearance. When the distance between the object and the projection plane is fixed and the projection centre and the object lie on opposite sides of the projection plane, increasing the distance (d) between the projection centre and the projection plane gives enlarged and flattened representations. When the distance (d) is fixed and the object and the projection centre lie on opposite sides of the projection plane, increasing the distance between the object and the projection plane gives reduced and flattened representations.

8D.6 Principles and Methods of Depiction

8D.6.1 Piercing Method

Using the piercing method, the piercing points of projectors with the projection plane are shown by basic plane and elevation, and may be determined either by drawing or by calculation (see Fig. 8D.10).

The piercing method allows even complex objects (round shapes, helicoids, etc) to be easily represented in central projection

8D.6.2 Trace Point — Vanishing Point Methods

With the trace point — vanishing point methods, the outlines and edges of the object to be depicted are imaged from basic plane and elevation.

8D.6.2.1 Trace point — Vanishing point Method A (special position of the object)

In Method A, one vertical face of the object is parallel to the vertical projection plane (special position of the object with respect to the projection plane), so that the vanishing point for those edges parallel to the projection plane is situated at infinity and the vanishing point for those edges perpendicular to the projection plane is the main point (see Fig. 8D.11).

8D.6.2.2 Trace point — Vanishing point Method B (particular position of the object)

In Method B, horizontal faces of the object are perpendicular to the vertical projection plane (particular position of the object with respect to the projection plane) so that the lines are represented by their trace on the projection plane and by their vanishing point (see Fig. 8D.12).

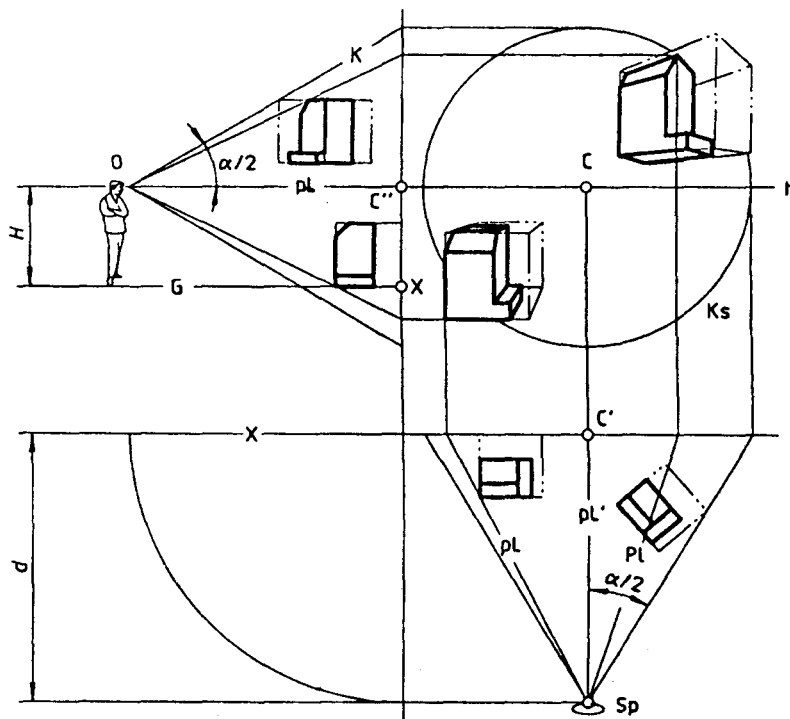


FIG. 8D.10 PROJECTION MODEL TURNED INTO THE DRAWING SURFACE WITH SIDE VIEW

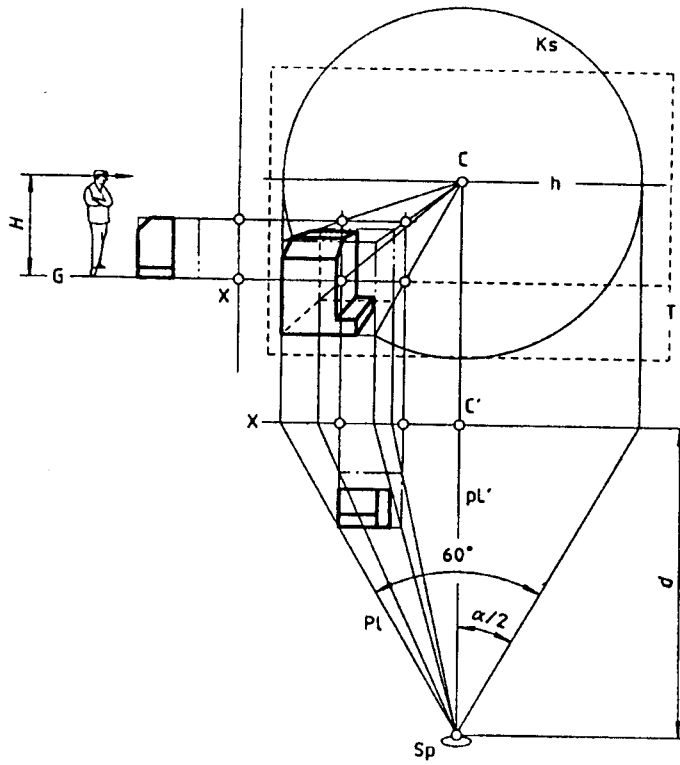


FIG. 8D.11 OBJECT, FRAMED IN A CUBE (INDICATED BY A DOUBLE-DASHED LINE), IN SPECIAL POSITION WITH RESPECT TO THE PROJECTION PLANE ACCORDING TO METHOD A

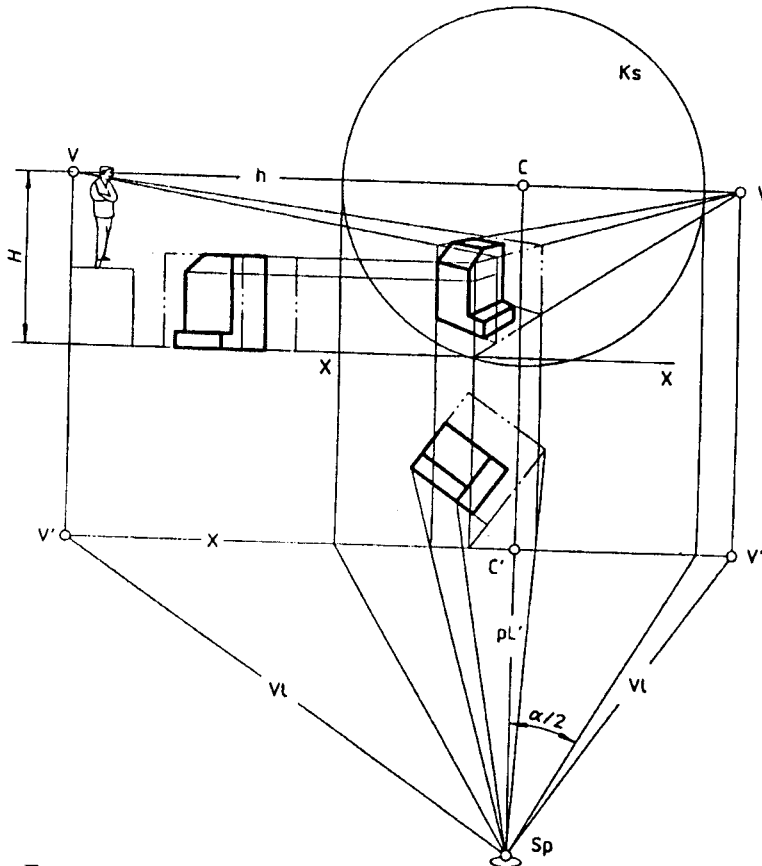


FIG. 8D.12 OBJECT, FRAMED IN A CUBE (INDICATED BY A DOUBLE-DASHED LINE), IN PARTICULAR POSITION WITH RESPECT TO THE PROJECTION PLANE ACCORDING TO METHOD B

8D.6.3 Distance Point Method
(Special position of the object)

The distance point method gives the central projection of an object without its basic plane, by setting up a perspective grid. The outlines and edges are parallel or perpendicular to the projection plane (special position). The distance point has the same distance from the main point as the projection centre from the projection plane. All horizontal lines inclined at 45° with respect to the projection plane align to the distance point. The vanishing point of the depth lines of the grid is the main point (see Fig. 8D.13).

8D.6.4 Scale Point Method
(Particular position of the object)

For any vanishing point there is a corresponding scale point. With the aid of scale points, certain dimensions of the object to be depicted may be transferred from the basic line in the projection plane on depth lines (see Fig. 8D.14). By means of the basic plane, a definite relation between the perspective representation of the object and the object itself may be established.

8D.6.5 Trace Point Method with Inclined Projection Plane

8D.6.5.1 Inclined projection plane $\beta < 90^\circ$

Due to the inclination of the projection plane with

respect to the horizon plane, the vanishing point for the vertical lines of the object to be depicted moves from infinite to finite. The angle β , that is the angle of the inclination of the projection plane with respect to the horizon plane, defines the position of the vanishing point above the horizon. Vertical object lines are represented as tilting lines, which gives an optical distortion suggesting a tapering form (see Fig. 8D.15).

8D.6.5.2 Inclined projection plane $\beta > 90^\circ$

Due to the inclination away from the projection centre, the vanishing point for vertical lines of the object to be depicted moves below the horizon line from infinite to finite, so that tilting projected vertical lines provide an optical distortion suggesting a tapering form (see Fig. 8D.16).

8D.6.6 Coordinate Piercing Method

The coordinate piercing method is based on simple proportions, in which each piercing point of the projectors in the projection plane is not established by drawing, but by calculation. This method is based on dividing the space in four quadrants by two reference planes, one horizontal and one vertical, each perpendicular to the projection plane, their common line being the main projector. The common lines of the

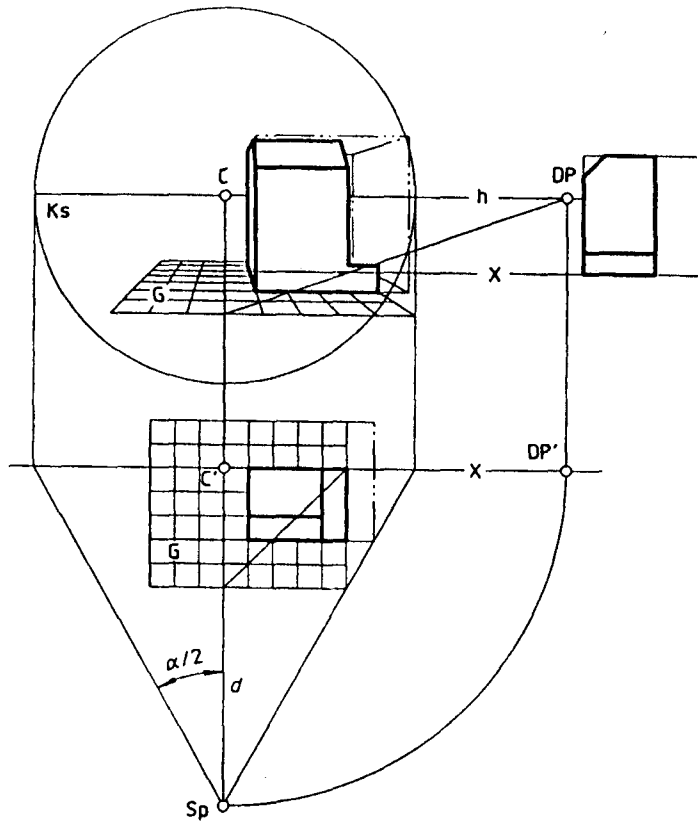


FIG. 8D.13 OBJECT, FRAMED IN A CUBE (INDICATED BY A DOUBLE-DASHED LINE), IN SPECIAL POSITION WITH RESPECT TO THE PROJECTION PLANE

8D.7.2 Turning the Projection Plane Downwards

The basic line becomes the axis of symmetry. This frequently-used arrangement saves space on the drawing surface and is called economy arrangement (see Fig. 8D.19).

8D.8 Examples of Comparison of Different Depiction Methods

Figures 8D.20, 8D.21 and 8D.22 illustrate some of the different depiction methods described in 8D.6.

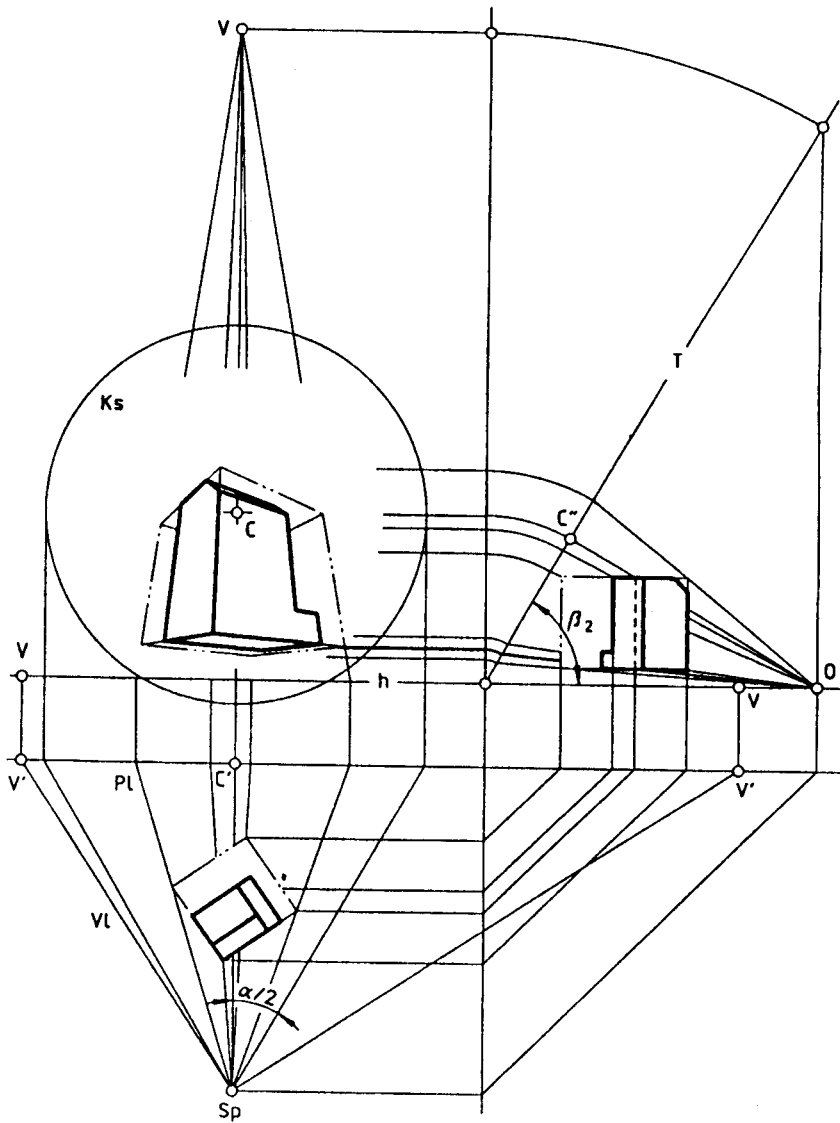


FIG. 8D.15 OBJECT, FRAMED IN A CUBE (INDICATED BY A DOUBLE-DASHED LINE), IN FRONT OF A PROJECTION PLANE INCLINED TOWARDS THE PROJECTION CENTRE

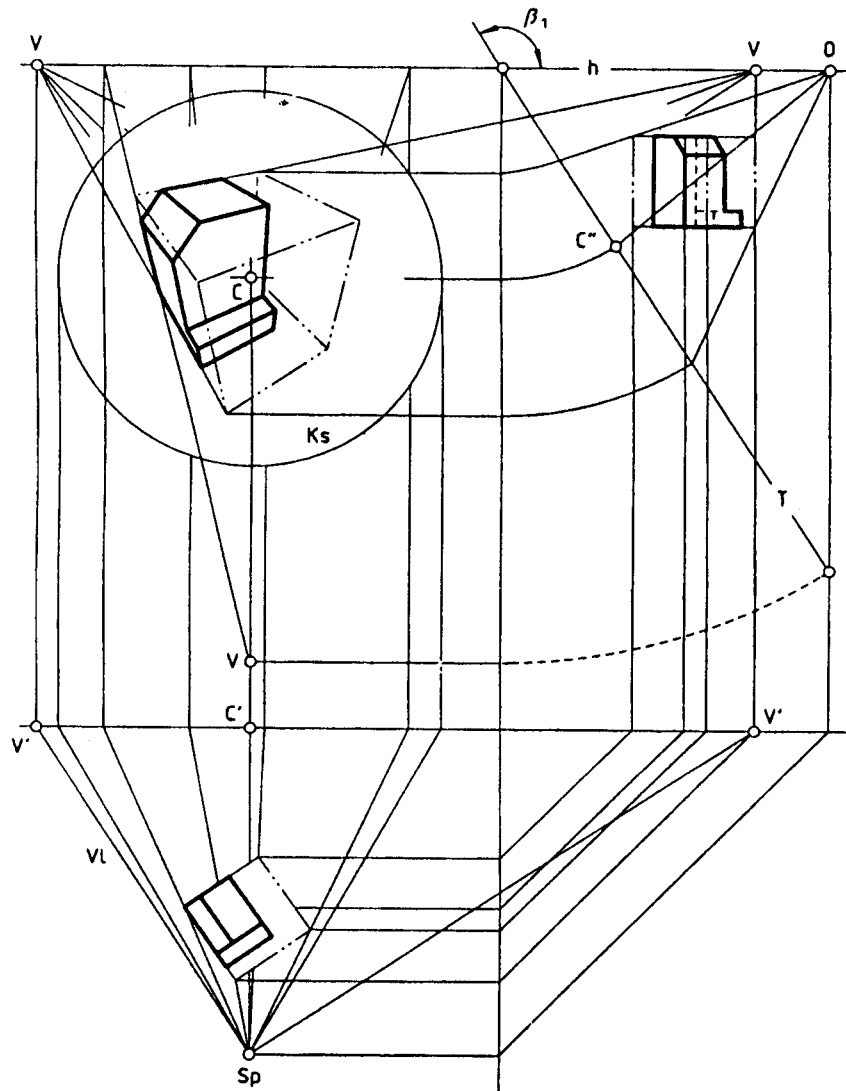


FIG. 8D.16 OBJECT, FRAMED IN A CUBE (INDICATED BY A DOUBLE-DASHED LINE), IN FRONT OF A PROJECTION PLANE INCLINED AWAY FROM THE PROJECTION CENTRE

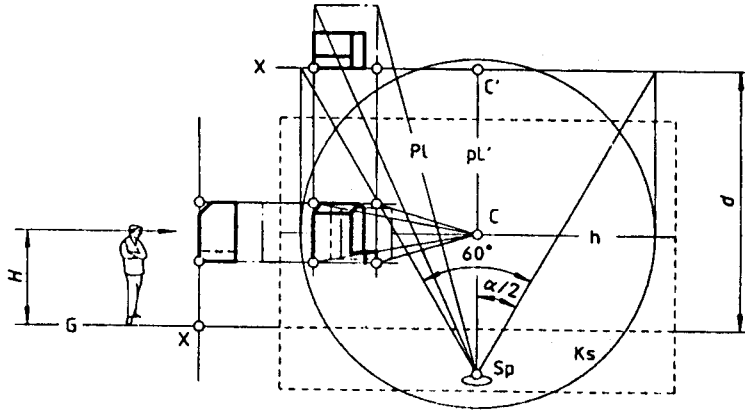


FIG. 8D.19 ECONOMY ARRANGEMENT (THE PERSPECTIVE REPRESENTATION IS PLACED BELOW THE BASIC LINE X)

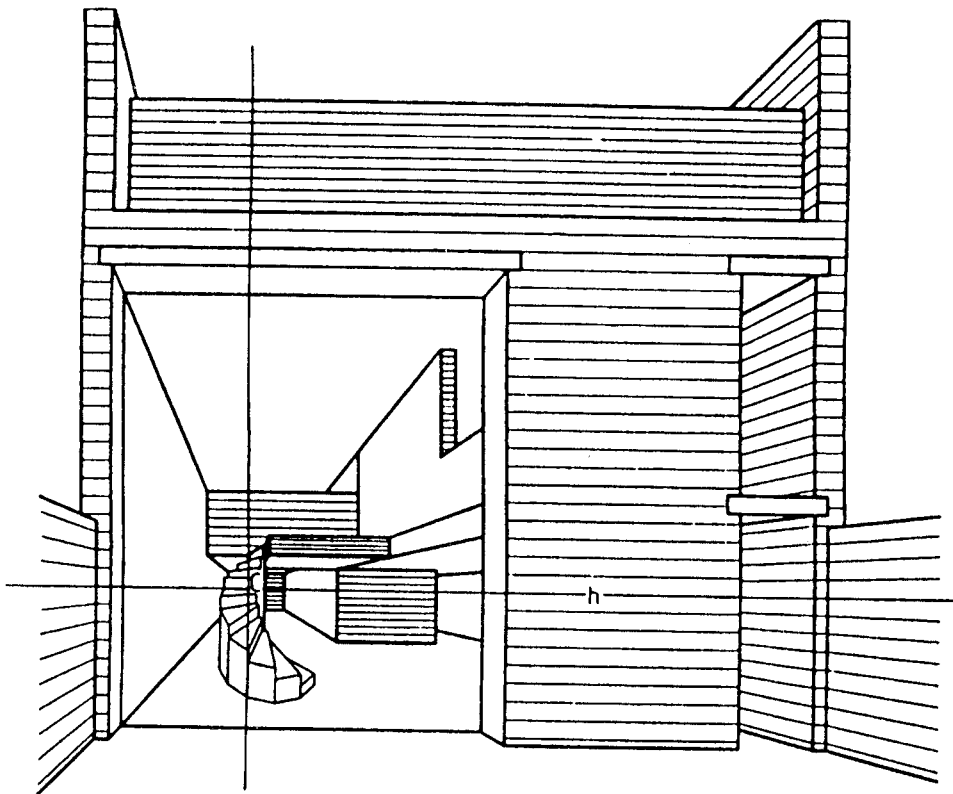


FIG. 8D.20 EXTERIOR SPACE IMAGE, PROJECTION WITH ONE VANISHING POINT; THE SPIRAL STAIRCASE HAS BEEN REPRESENTED ACCORDING TO THE METHOD DESCRIBED IN 8D.6.1

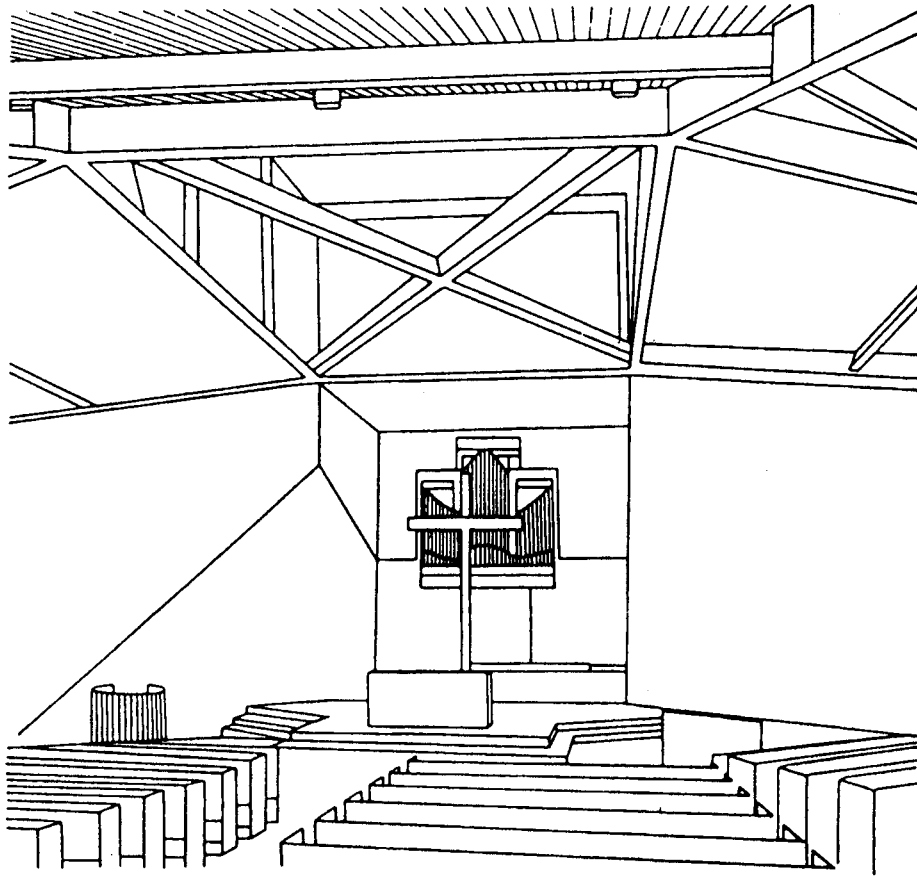


FIG. 8D.21 INTERIOR SPACE IMAGE, PROJECTION ACCORDING TO THE METHOD DESCRIBED IN 8D.6.2 WITH VARIOUS VANISHING POINTS AND THE REPRESENTATION OF INCLINED PLANES

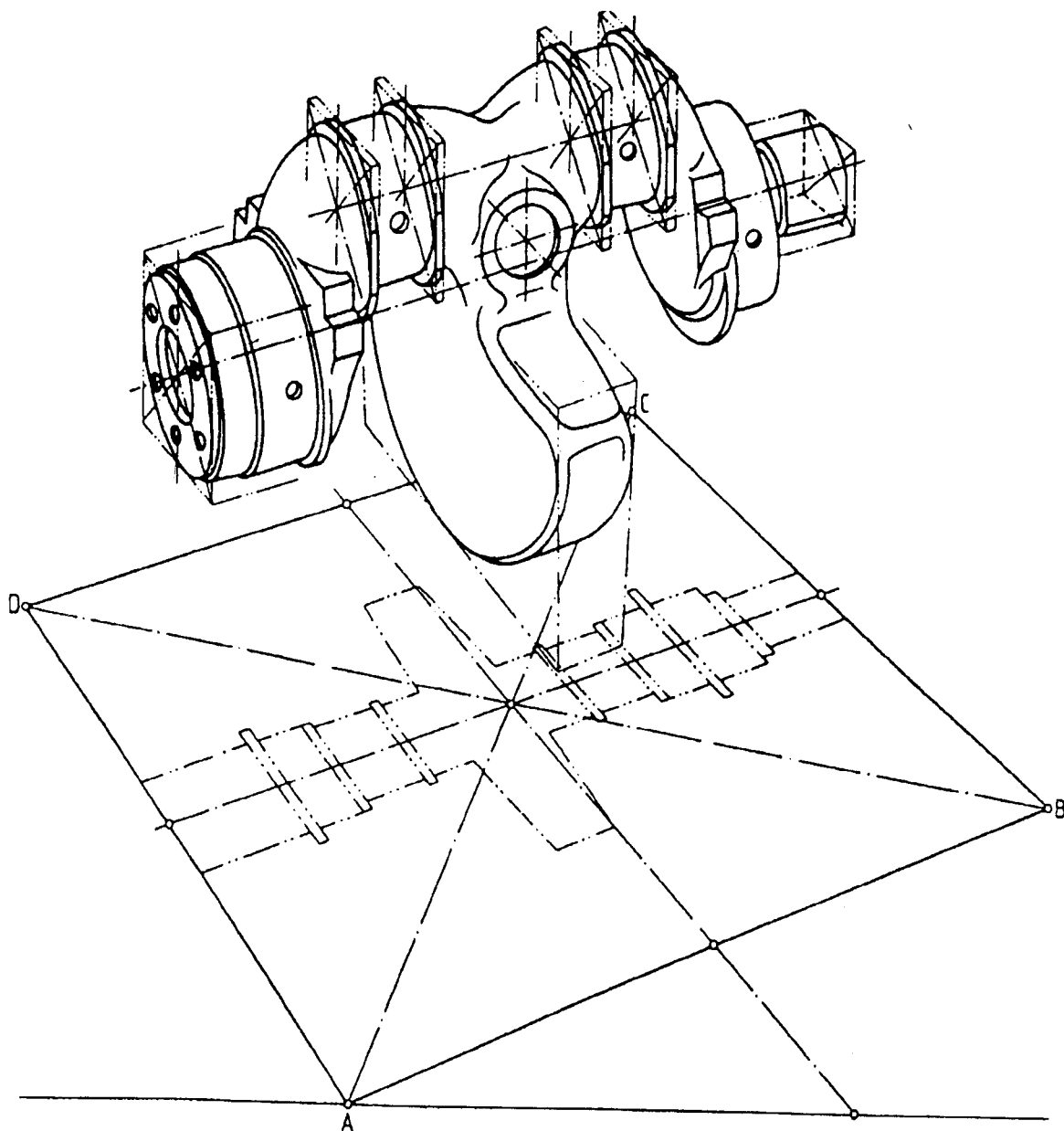


FIG. 8D.22 EXAMPLE OF DIMETRIC AXONOMETRY, REPRESENTATION OF AN ENGINE CRANKSHAFT

SECTION 9 TECHNICAL DRAWINGS — SIMPLIFIED REPRESENTATION OF PIPELINES — GENERAL RULES, ORTHOGONAL REPRESENTATION AND ISOMETRIC PROJECTION

[Based on IS 10990 (Part 1) : 1991/ISO 6412-1 : 1989 and
IS 10990 (Part 2) : 1992/ISO 6412-2 : 1989]

9.1 Representation of Pipes, Etc

The flow line representing a pipe, etc, irrespective of its diameter), shall be a single continuous wide line (see Table 9.1 and Section 6), coinciding with the central line of the pipe (see ISO 4067-1).




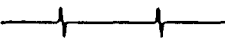

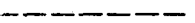



Bends may be simplified by extending the straight length of the flow line to the vertex (see Fig. 9.1). However, bends may be shown for sake of clarity in

the form illustrated in Fig. 9.2. In this case, if projections of bends would otherwise have been elliptical, these projections may be simplified by drawing circular arcs (see Fig. 9.3).

9.1.1 Types of Line

The types and thickness of line shown in Section 6 shall be used.

Table 9.1 Types of Line
(Clause 9.1)

Line type in accordance with IS 10714 (Part 20)	Description	Application
01.2 	Continuous wide line	.1 Flow lines and connected parts
01.1 	Continuous narrow line	.1 Hatching
		.2 Dimensioning
		.3 Leader lines
		.4 Isometric grid lines
01.1 	Continuous narrow free hand line	.1.1 Limits of partial or interrupted views and sections
01.1 	Continuous narrow line with zigzags	
02.2 	Dashed wide line	.1 Flow lines specified on other drawing
02.1 	Dashed narrow line	.1 Floor
		.2 Walls
		.3 Ceilings
		.4 Holes (hole punchings)
04.1 	Long dashed dotted narrow line	.1 Centrelines
04.3 	Long dashed dotted extra wide line ¹⁾	.1 Contract boundary
05.1 	Long dashed double dotted narrow line	.1 Outlines of adjacent parts
		.2 Parts situated in front of the cutting plane
¹⁾ Four times the thickness of line type 04.1		

9.1.1.1 Spacing of lines

In accordance with IS 10164, the space between parallel lines (including hatching) shall not be less than twice the thickness of the heaviest of these lines, with a minimum spacing of 0.7 mm.

The minimum spacing between adjacent flow lines and between flow lines and other lines should be 10 mm.

9.1.2 Lettering

Lettering shall be in accordance with IS 9609 (Part 1); lettering Type B vertical is preferred. The line thickness of the lettering shall be the same as the line thickness of those tpd-symbols to which the lettering is close or associated (see ISO 3461-1).

9.1.3 Dimensioning

9.1.3.1 In general, dimensioning shall be in accordance with IS 11669. Nominal dimensions may be indicated in accordance with ISO 3545 using the short designation 'DN' (see Fig. 9.1).

The outer diameter (d) and the wall thickness (t) of pipes may be indicated in accordance with IS 10720 (see Fig. 9.2). If necessary, an item list (see IS 11666) giving additional information on the pipes, including the associated equipment, may be added to the drawing. Lengths shall start from the outer faces of the pipe ends, flanges, or centre of the joint, whenever appropriate.

9.1.3.2 Pipes with bends should be generally dimensioned from central line to central line of the pipelines (see Fig. 9.1 and Fig. 9.2).

If it is necessary to specify the dimension from the outside or inside external protection or surface of the pipe, the dimension may be specified by arrows pointing to short thin strokes parallel to the projection line (see Fig. 9.3).

The dimensions from outer to outer, from inner to inner and from inner to outer vertex are shown in Fig. 9.3 (a), 9.3 (b) and 9.3 (c), respectively.

9.1.3.3 Radii and angles of bends may be indicated as shown in Fig. 9.4.

The functional angle shall be indicated; in general, angles of 90° are not indicated.

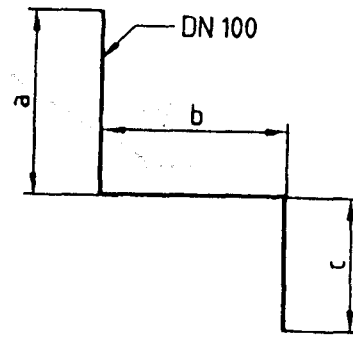


FIG. 9.1

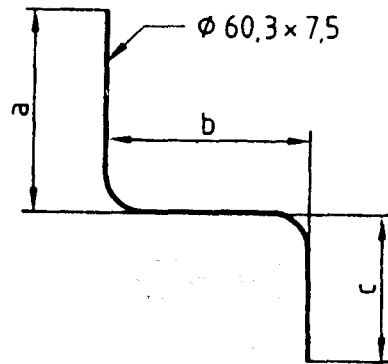


FIG. 9.2

9.1.3.4 Levels refer generally to the centre of the pipe and should be indicated in accordance with IS 11669 (see Fig. 9.5). If, in special cases, it is necessary to specify the level to the bottom of a pipe this shall be indicated by the reference arrow pointing to short thin strokes, as specified in 9.1.3.2 [see Fig. 9.3 and Fig. 9.8 (a)].

A similar rule shall be applied to indicate levels to the top of the pipe [see Fig. 9.8 (c)].

9.1.3.5 The direction of slope shall be indicated by a right-angled triangle above the flow line, pointing from the higher down to the lower level.

The amount of slope shall be indicated in accordance with the methods shown in Fig. 9.6 to 9.8.

It may be useful to specify the level of the sloping pipe, either at its higher or at its lower end, or at any

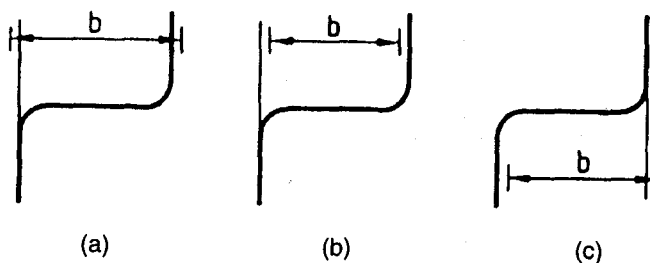


FIG. 9.3

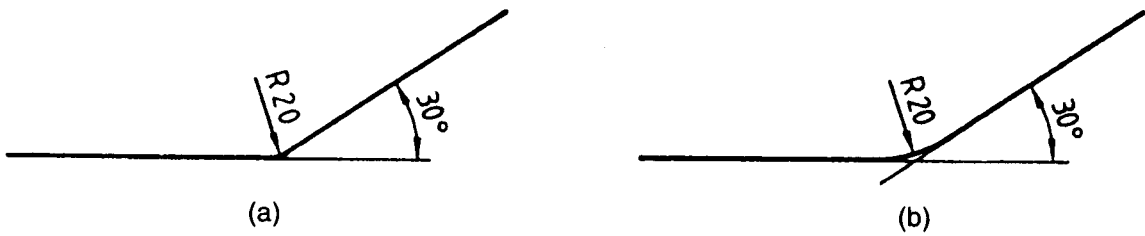


FIG. 9.4

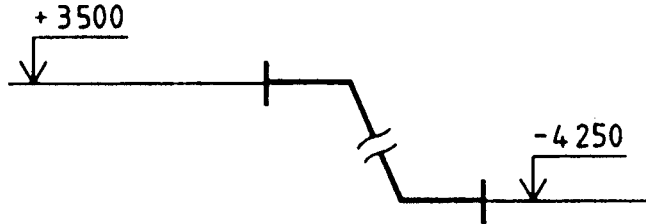


FIG. 9.5

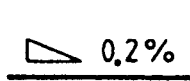
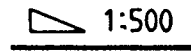
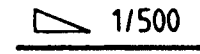


FIG. 9.6



(a)



(b)

FIG. 9.7

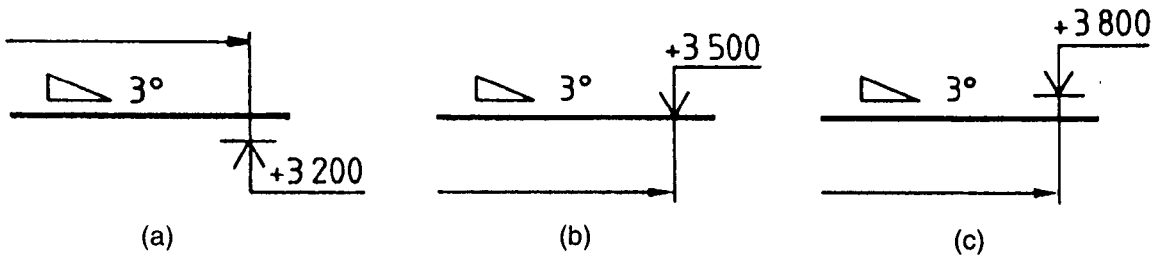


FIG. 9.8

convenient point, by referring to a datum level (see Fig. 9.8).

9.1.3.6 The positions of the ends of the pipe shall be specified by indicating the coordinates referring to the centres of the end faces.

9.1.4 Tolerances

Tolerances shall be indicated in accordance with IS 11667.

9.2 Crossings and Connections

9.2.1 Crossings without connections shall normally be depicted without interrupting the flow line representing the hidden pipe (see Fig. 9.9; see also ISO 4067-1); if, however, it is absolutely necessary to indicate that one pipe has to pass behind the other, the flow line representing the hidden pipe shall be interrupted (see Fig. 9.10). The width of each interruption shall not be less than five times the thickness of the continuous line (see Fig. 9.11).

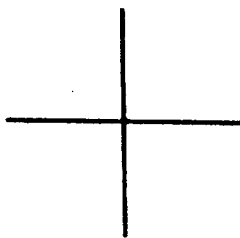


FIG. 9.9

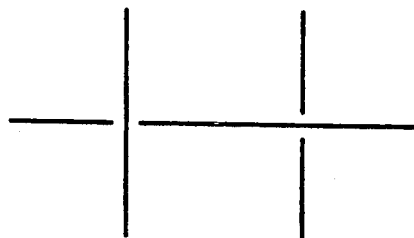


FIG. 9.10

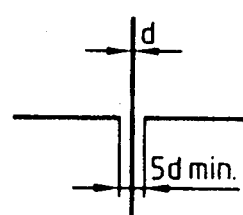


FIG. 9.11

9.2.2 Permanent junctions (whether made by welding or other processes) shall be marked by a prominent dot in accordance with ISO 1219 (see Fig. 9.12). The diameter of the dot shall be five times the thickness of the line.

9.2.3 Detachable connections should be represented in accordance with ISO 4067-1.

9.3 Representation of Equipment

9.3.1 General

All items of equipment, machinery, valves, etc. shall be represented by means of graphical symbols with the same line thickness as the flow line (see ISO 3461-2).

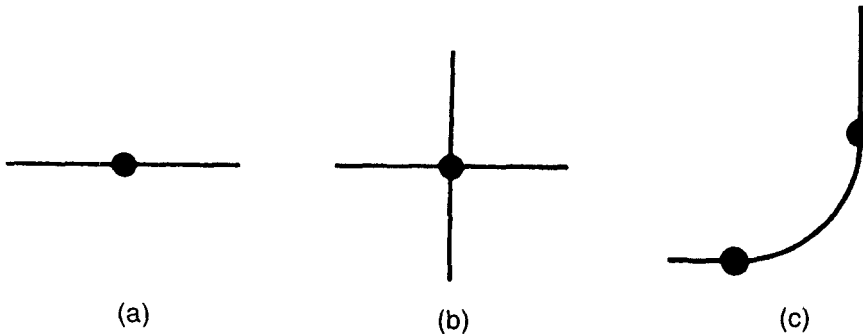


FIG. 9.12

9.3.2 Fittings

9.3.2.1 Fittings, such as, nozzles, tee-pieces and bends, should be drawn with the same line thickness as the flow line.

9.3.2.2 Transition pieces for changing the cross-section shall be represented in accordance with Fig. 9.13 to 9.15.

The relevant nominal sizes shall be indicated above the symbols.

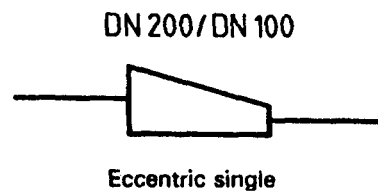


FIG. 9.15

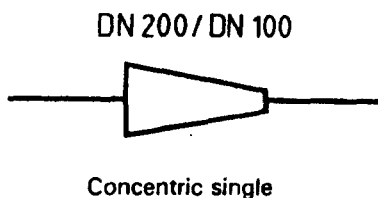


FIG. 9.13

DN 200 / DN 100 - DN 100 / DN 50 or
DN 200 / DN 100 / DN 50

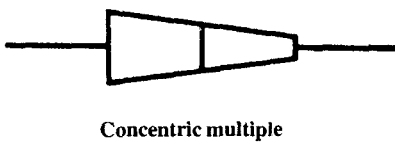


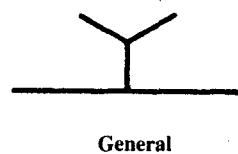
FIG. 9.14

9.3.3 Supports and Hangers

Supports and hangers shall be represented by their appropriate symbols in accordance with Fig. 9.16 to 9.19.

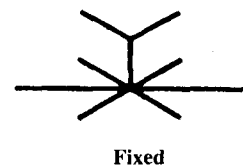
The representation of repeated accessories may be simplified as shown in Fig. 9.20.

NOTE — Figure 9.16 to 9.19 refer to hangers only. It should be understood that in case of supports, the same symbols should be used, but in the reverse position.



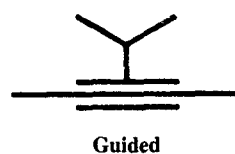
General

FIG. 9.16



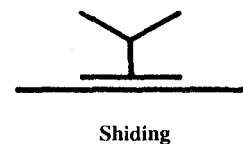
Fixed

FIG. 9.17



Guided

FIG. 9.18



Sliding

FIG. 9.19

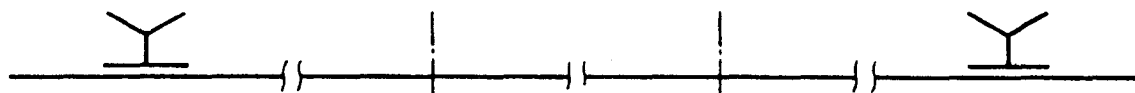


FIG. 9.20

If necessary, an alphanumerical code giving more information about the type of supports and hangers, with their numbering, may be added to the symbols shown in Fig. 9.16 to 9.19. The code giving the numbering shall be given on the drawing or in associated documents (see Fig. 9.21).



FIG. 9.23



FIG. 9.24

9.3.7 Flanges

Flanges shall be represented, irrespective of their type and sizes,

- by two concentric circles for the front view,
- by one circle for the rear view,
- by a stroke for the side view,

using lines of the same thickness as used for the representation of the pipes (see Fig. 9.22 and 9.25). A simplified representation of the flange holes may be shown by the appropriate number of crosses at their centrelines.

9.4 Examples

An example of orthogonal projection is given in Fig. 9.25.

NOTE — Other examples are given in ISO 3511-3 and ISO 3753.

9.5 Coordinates

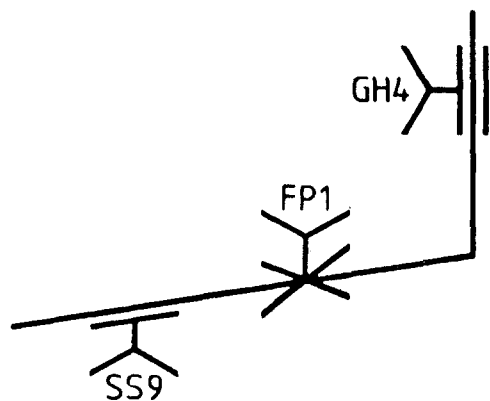
As far as it is necessary to use Cartesian coordinates, for instance for calculations or numerical control of machine tools, the coordinate axes shall comply with Fig. 9.26.

In all cases, the coordinates of individual pipes or pipe assemblies should comply with those adopted for the complete installation and shall be indicated on the drawing or in an associated document.

9.6 Deviations from the Direction of Coordinate Axes

9.6.1 General

Pipes, or parts of pipes, running parallel to the coordinate axes, shall be drawn parallel to the relevant axis without any further indication.



FP1: Fixing point No. 1
 SS9: Sliding support No. 9
 GH4: Guiding hanger No. 4

FIG. 9.21

9.3.4 Additional Provisions

Additional provisions such as insulation, coating, stream tracer lines, etc. may be specified in writing.

9.3.5 Adjoining Apparatus

If needed, adjoining apparatus, such as tanks, machinery, not belonging to the piping itself, may be represented by their outlines using long dashed double dotted narrow lines (see Table 9.1 and Section 6) as shown in Fig. 9.22.

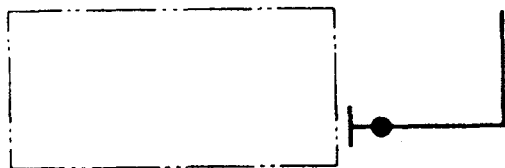
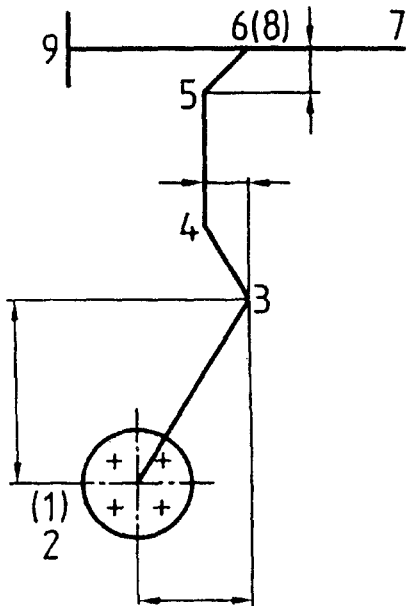


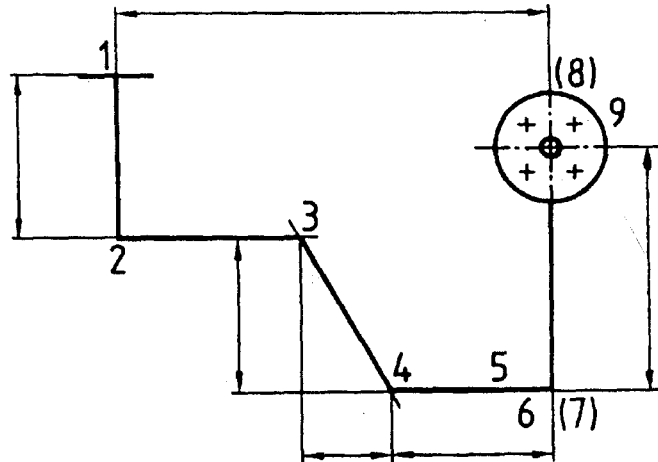
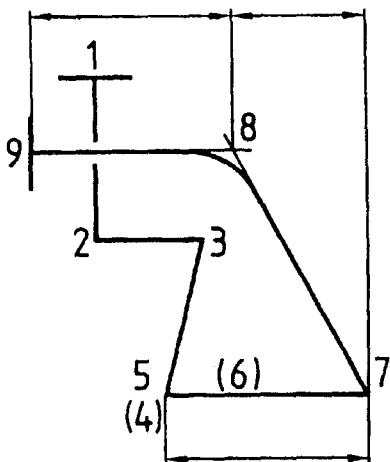
FIG. 9.22

9.3.6 Direction of Flow

The direction of flow shall be indicated by an arrowhead (see ISO 4067-1) on the flow line or near a graphical symbol representing a valve (see Fig. 9.23 and 9.24).



Reference number	Coordinates of the end points		
	$x_1 = -8$ $x_9 = -20$	$y_1 = +72$ $y_9 = 0$	$z_1 = +50$ $z_9 = +40$
1			
9			



NOTE — Points at which the pipe changes direction and connections are indicated by reference numbers. The pipe and the reference numbers are identical to those in the isometric representation illustrated in Fig. 9.48. Reference numbers for points hidden behind other points are shown in brackets.

FIG. 9.25

Deviations from the directions of the coordinate axes should be indicated by means of auxiliary hatched projection planes as shown in Fig. 9.27.

9.6.2 Pipes in a Vertical Plane

Pipes, or parts of pipes, situated in a vertical plane, shall be indicated by showing their projections on a horizontal plane [see Fig. 9.28 (a)].

9.6.3 Pipes in a Horizontal Plane

Pipes, or parts of pipes, situated in a horizontal plane, shall be indicated by showing their projections on a vertical plane [see Fig. 9.28 (b)].

9.6.4 Pipes not Parallel to any Coordinate Plane

Pipes, or parts of pipes, not running parallel to any coordinate plane, shall be indicated by showing both

their projections on a horizontal and on a vertical plane [see Fig. 9.28 (c)].

9.6.5 Auxiliary Projection Planes

It is recommended that the right angles of the triangles limiting the auxiliary projection planes be indicated.

Auxiliary projection planes may be emphasized by hatchings, parallel to the X- or Y-axis for horizontal auxiliary planes, and vertical for all other auxiliary planes.

If such hatching is not convenient it may be omitted, but in that case the rectangle (see Fig. 9.29) or the rectangular prism (see Fig. 9.30), of which a diagonal coincides with the pipe, should be shown, using continuous narrow lines (01.1).

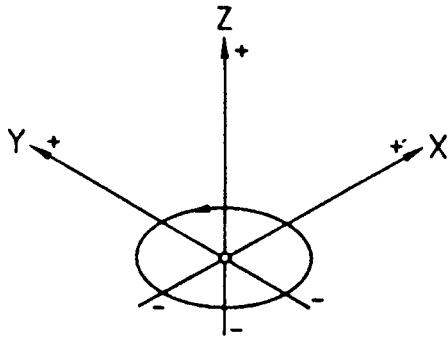


FIG. 9.26

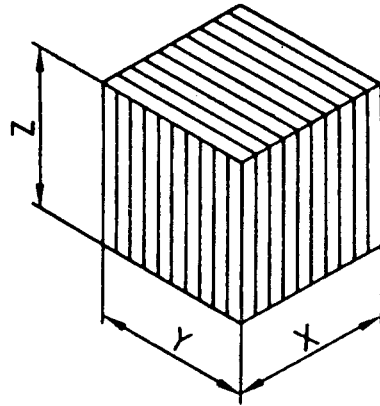


FIG. 9.27

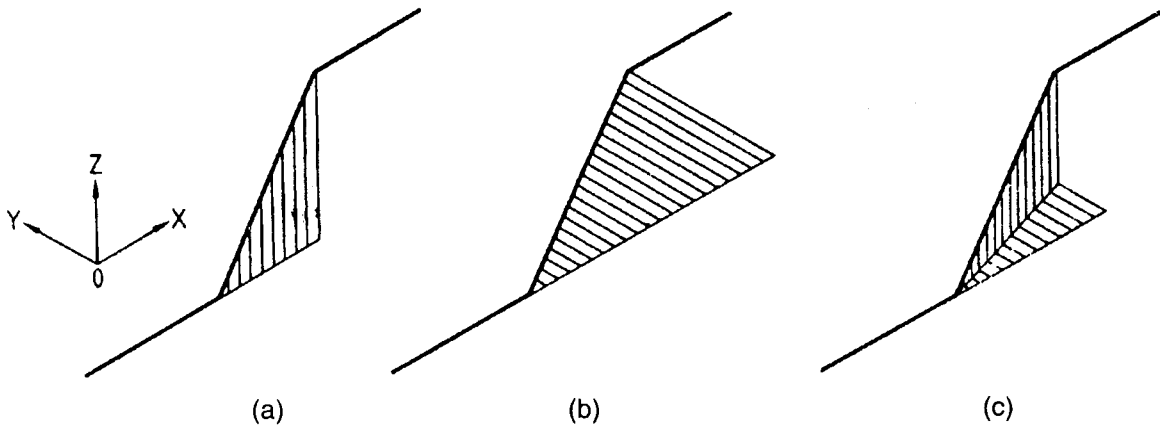


FIG. 9.28

9.7 Dimensioning and Special Rules

9.7.1 General

Drawings shall be dimensioned in accordance with IS 11669. There are, however, special rules for isometric projection for pipelines which are specified in 9.7.2 to 9.7.10.

9.7.2 Diameters and Wall Thickness

The outer diameter (d) and the wall thickness (t) of pipes may be indicated in accordance with IS 10720 (see Fig. 9.31). Nominal dimensions may be indicated in accordance with ISO 3545 using the short designation 'DN' (see Fig. 9.1).

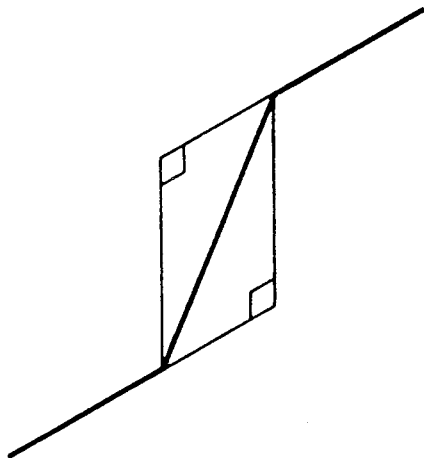


FIG. 9.29

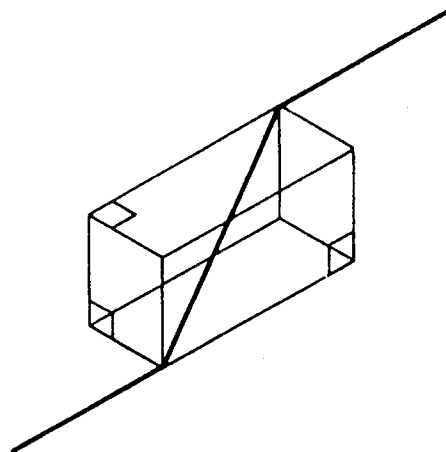


FIG. 9.30

9.7.3 Longitudinal and Angular Dimensions

Longitudinal and angular dimensions shall be indicated in accordance with IS 11669; the length shall start from the outer faces of the pipe ends, flanges, or centre of the joint, whenever appropriate.

9.7.4 Pipes with Bends

Pipes with bends shall be dimensioned from central line to central line or from the central line to the end of the pipe (see Fig. 9.31).

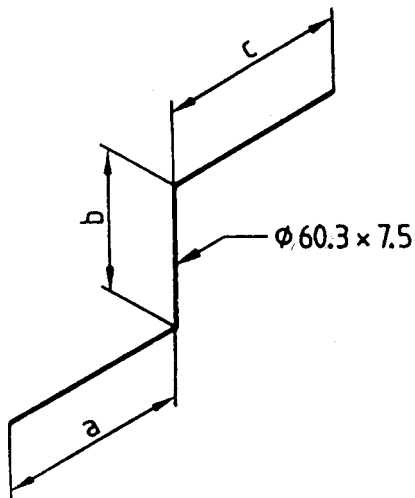


FIG. 9.31

9.7.5 Radii and Angles of Bends

Radii and angles of bends may be indicated as shown in Fig. 9.32.

The functional angle shall be indicated.

NOTE — Bends may be simplified by extending the straight length of the flow line to the vertex. However, the actual bends in the pipes may be shown for sake of clarity. In this case, if projections of bends would otherwise have been elliptical, these projections may be simplified by drafting circular arcs.

9.7.6 Levels

Levels should be indicated in accordance with IS 11669 and IS 10990 (Part 1) (see Fig. 9.33).

The horizontal part of the leader line shall follow the direction of the associated flow line.

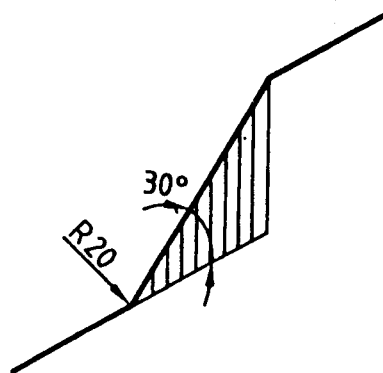


FIG. 9.32

9.7.7 Direction of Slope

The direction of slope shall be indicated by a right-angled triangle above the flow line, pointing from higher down to the lower level, without changing the isometric direction of the flow line.

The amount of slope shall be indicated in accordance with the method shown in Fig. 9.34 and in IS 10990 (Part 1).

It may, however, be useful to specify the slope by referring to a datum level (see Fig. 9.34).

9.7.8 Positions of Ends of Pipes

If necessary, the positions of the ends of the piping may be specified by indicating the coordinates referring to the centres of the end faces.

In the case of adjacent drawings, a reference should be given. For example, 'continued on drawing x'.

9.7.9 Redundant Dimensioning

If necessary, the auxiliary hatched projection planes can be dimensioned (see Fig. 9.35).

If it is necessary for manufacturing and/or technical reasons to indicate double dimensioning, one of the dimensions should be indicated in parenthesis.

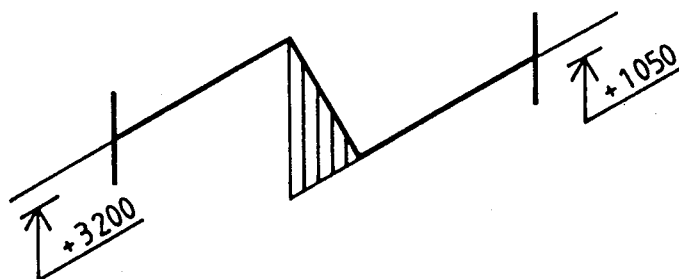


FIG. 9.33

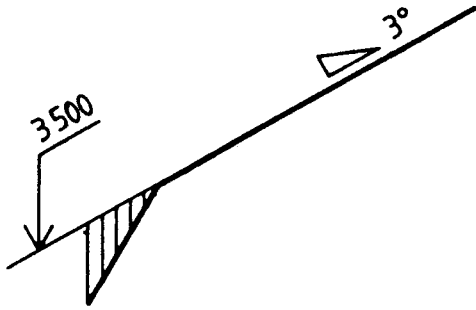


FIG. 9.34

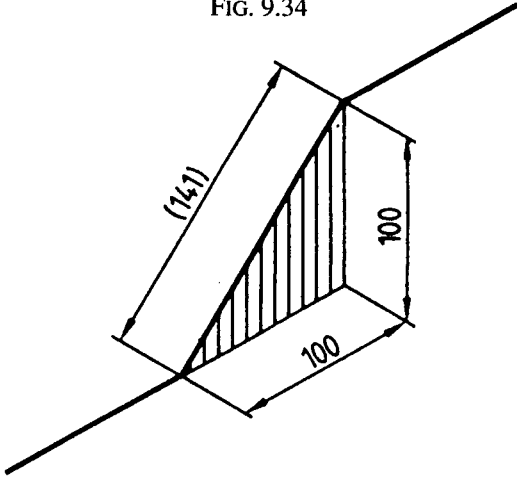


FIG. 9.35

9.7.10 Dimensioning for Pipe-bending Machines

The dimensioning is defined on the basis of a reference system (point of origin) (see Fig. 9.48).

9.8 Graphical Symbols

9.8.1 General

Graphical symbols for pipeline systems shall be drawn using the isometric projection method (see Fig. 9.36).

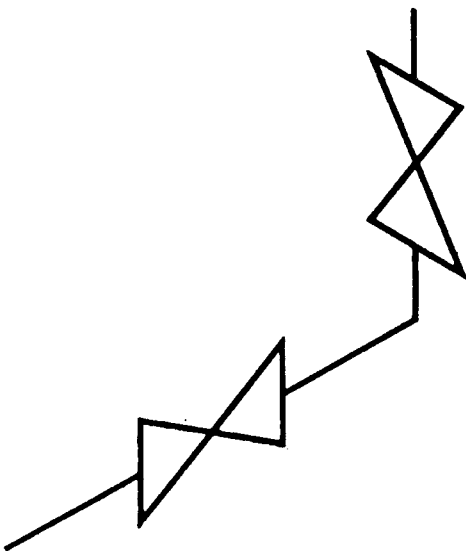


FIG. 9.36

9.8.2 Examples of Graphical Symbols Drawn with the Isometric Projection Method

9.8.2.1 Valves

See examples in Fig. 9.37 and 9.38.

NOTE — Valve actuators should only be shown if it is necessary to define their positions or the kind of actuators (spindle, piston, etc.).

If shown, an actuator with a position parallel to one of the coordinate axes need not be dimensioned. Deviations from such positions should be indicated (see Fig. 9.38).

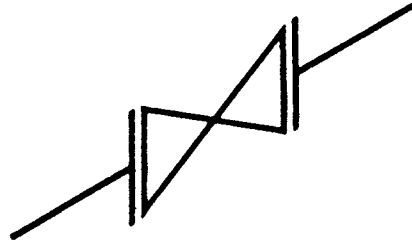


FIG. 9.37

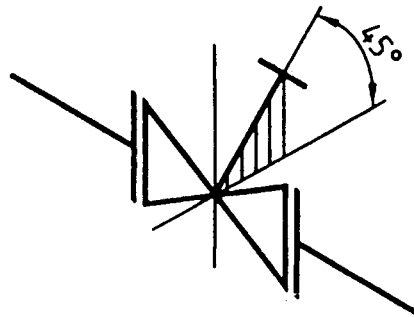


FIG. 9.38

9.8.2.2 Transition pieces (Cones)

The relevant nominal sizes shall be indicated above the graphical symbols (see Fig. 9.39).

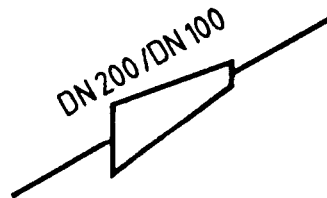


Fig. 9.39

9.8.2.3 Supports and hangers

See examples given in Fig. 9.40 and 9.41 (see also 9.3.3).

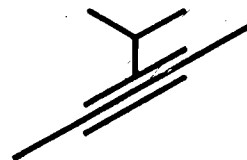


FIG. 9.40

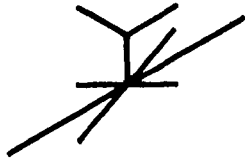


FIG. 9.41

9.8.2.4 Crossings

Crossings shall be shown in accordance with 9.2.

If it is absolutely necessary to indicate that one pipe has to pass behind the other, the flow line representing the hidden pipe shall be interrupted (see Fig. 9.42). The width of each interruption shall not be less than five times the thickness of the continuous line.

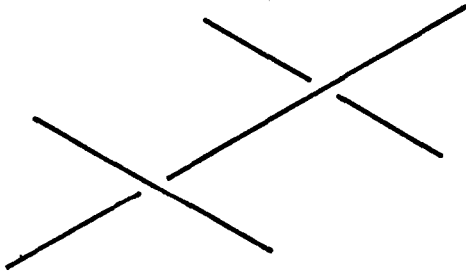


FIG. 9.42

9.8.2.5 Permanent junctions

See examples of a weld given in Fig. 9.43 and of a site weld in Fig. 9.44.

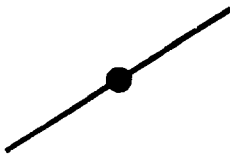


FIG. 9.43

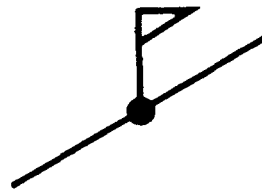


FIG. 9.44

9.8.2.6 General connections

If the kind, or type, of connection is not specified, a general symbol should be used (instead of the more detailed symbols given in ISO 4067-1).

See example given in Fig. 9.45.

9.8.2.7 Flanges

See examples in Fig. 9.46 and 9.47.

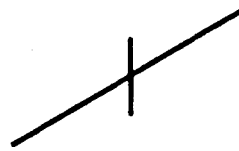


FIG. 9.45

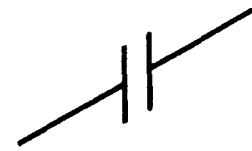


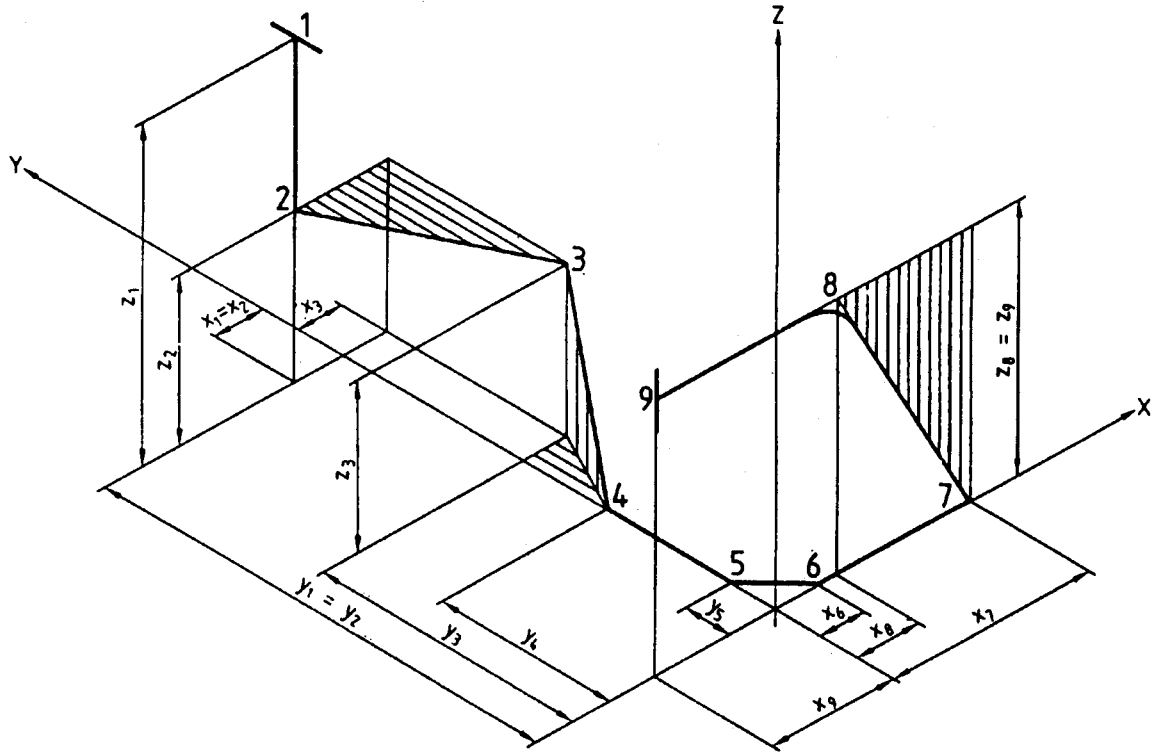
FIG. 9.46



FIG. 9.47

9.9 Examples

Examples of isometric projections are given in Fig. 9.48 and 9.49.



Reference Number	Coordinates		
1	$x_1 = -8$	$y_1 = +72$	$z_1 = +50$
2	$x_2 = -8$	$y_2 = +72$	$z_2 = +25$
3	$x_3 = +7$	$y_3 = +42$	$z_3 = +25$
4	$x_4 = 0$	$y_4 = +28$	$z_4 = 0$
5	$x_5 = 0$	$y_5 = +7$	$z_5 = 0$
6	$x_6 = +7$	$y_6 = 0$	$z_6 = 0$
7	$x_7 = +32$	$y_7 = 0$	$z_7 = 0$
8	$x_8 = +10$	$y_8 = 0$	$z_8 = +40$
9	$x_9 = -20$	$y_9 = 0$	$z_9 = +40$

NOTE — Points at which the pipe changes direction and connections are indicated by reference numbers. The pipe and the reference numbers are identical to those in the orthogonal representation illustrated in Fig. 9.25.

FIG. 9.48

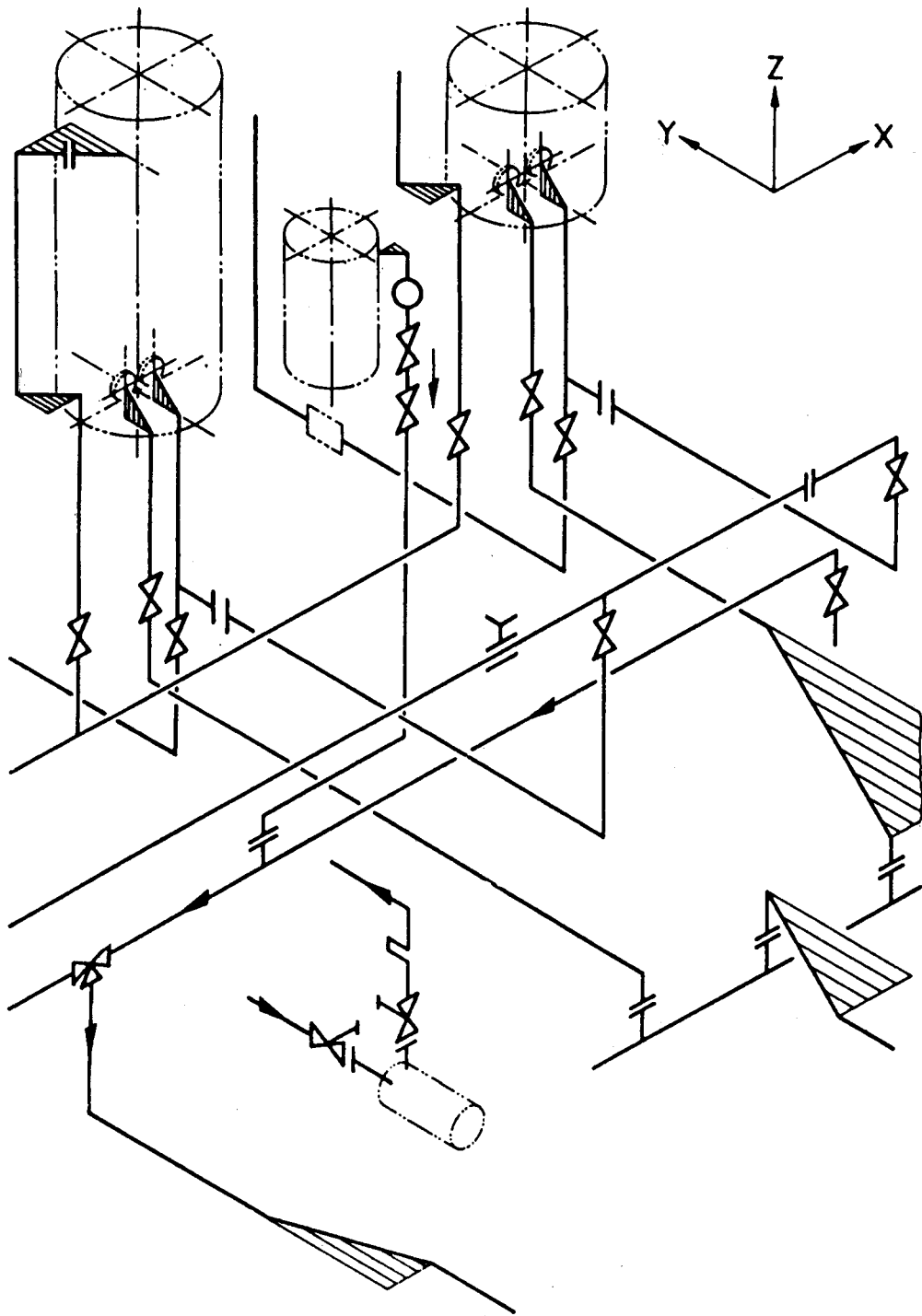


FIG. 9.49

SECTION 10 SECTIONS AND OTHER CONVENTIONS

[Based on IS 10714 : 1983/ISO 128 : 1982]

10.1 Scope

This section covers the methods of representation of sectional views and other conventions.

10.2 Sections

10.2.1 Notes on Hatching of Sections

10.2.1.1 Hatching is generally used to show areas of sections. Allowance must be made for the methods of reproduction that are to be used.

10.2.1.2 The simplest form of hatching is usually adequate for the purpose, and may be based upon continuous narrow lines (01.1) at a convenient angle, preferably 45°, to the principal outlines or lines of symmetry of the sections (see Fig. 10.1, 10.2 and 10.3).



FIG. 10.1



FIG. 10.2

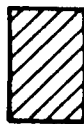


FIG. 10.3

10.2.1.3 Separate areas of a section of the same component shall be hatched in an identical manner. The hatching of adjacent components shall be carried out with different directions or spacings (see Fig. 10.4 and 10.5).

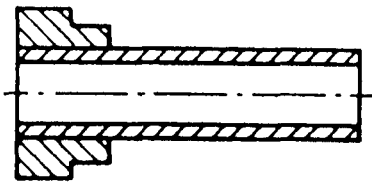


FIG. 10.4

10.2.1.4 Spacing between the hatching lines should be chosen in proportion to the size of the hatched areas, provided that the requirement for minimum spacing are maintained (see 6.5.1).

10.2.1.5 In the case of large areas, the hatching may be limited to a zone following the contour of the hatched area (see Fig. 10.5).

10.2.1.6 Where sections of the same part in parallel planes are shown side by side, the hatching shall be identical, but may be offset along the dividing line

between the sections if greater clarity is considered necessary (see Fig. 10.6).

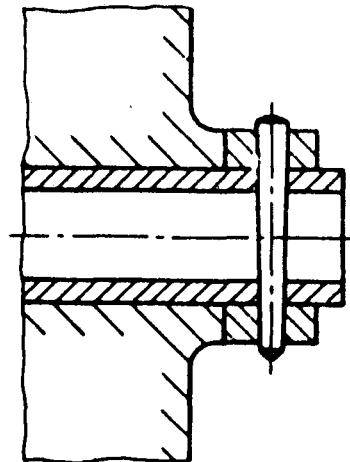


FIG. 10.5

A-A

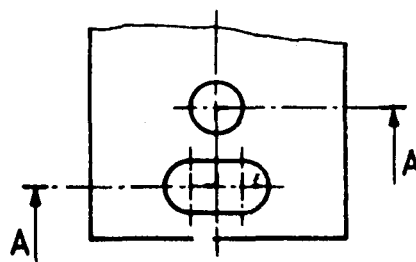
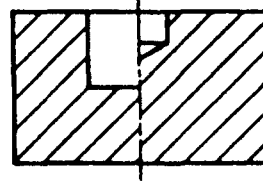


FIG. 10.6

10.2.1.7 Hatching shall be interrupted when it is not possible to place inscriptions outside the hatched area (see Fig. 10.7).

10.2.2 Hatching to Indicate Type of Materials

10.2.2.1 Hatching may be used to indicate type of materials in sections.

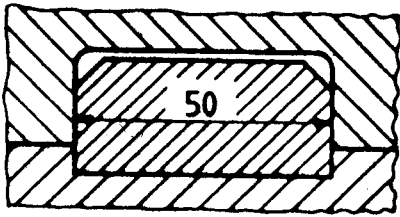


FIG. 10.7

10.2.2.2 If different types of hatching are used to indicate different materials, the meaning of these hatchings shall be clearly defined on the drawing or by reference to appropriate standards.

10.2.3 Thin Sections

Thin sections may be shown entirely black (see Fig. 10.8); a space of not less than 0.7 mm must be left between adjacent sections of this type (see Fig. 10.9).



FIG. 10.8



FIG. 10.9

10.2.4 Notes on Sections

10.2.4.1 The general rules for the arrangement of views (see 8B.3) apply equally when drawing sections.

10.2.4.2 Where the location of a single cutting plane is obvious, no indication of its position or identification is required (see Fig. 10.10 and 10.21).

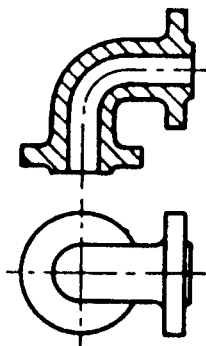


FIG. 10.10

10.2.4.3 Where the location is not obvious, or where it is necessary to distinguish between several cutting planes (see Fig. 10.11 to 10.15), the position of the cutting plane(s) shall be indicated by means of ends and changes of direction [combination of long dashed dotted narrow line (04.1) and long dashed dotted wide line (04.2)]. The cutting plane should be identified by designations, for example, capital letters, and the

direction of viewing should be indicated by arrows. The section should be indicated by the relevant designations (see Fig. 10.11 to 10.15).

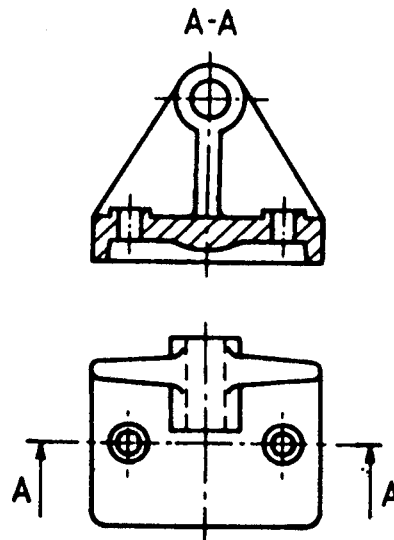


FIG. 10.11

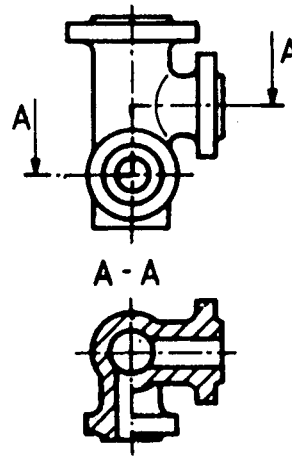


FIG. 10.12

10.2.4.4 The designations on the referenced sections shall be placed either immediately below or above the relevant sections, but in any one drawing the references shall be placed in the same way. No other indication is necessary.

10.2.4.5 In certain cases, the parts located beyond the cutting plane need not be drawn completely.

10.2.4.6 In principle, ribs, fasteners, shafts, spokes of wheels, and the like are not cut in the longitudinal sections, and therefore should not be hatched (see Fig. 10.14 and 10.15).

10.2.5 Cutting Planes (Examples)

10.2.5.1 Section in one plane (see Fig. 10.10 and 10.11).

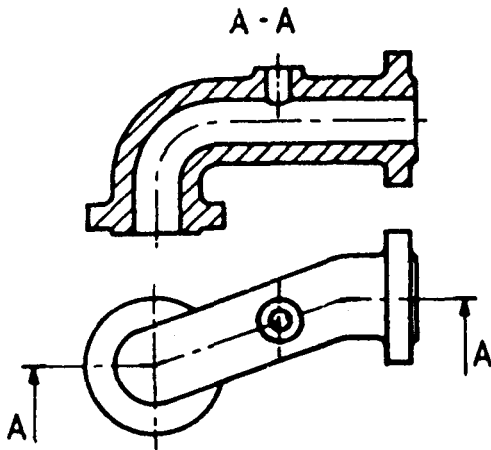


FIG. 10.13

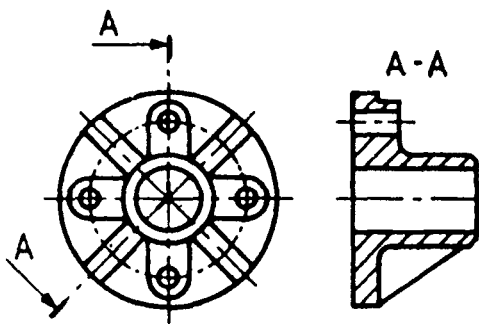


FIG. 10.14

10.2.5.2 Section in two parallel planes (see Fig. 10.12).

10.2.5.3 Section in three contiguous planes (see Fig. 10.13).

10.2.5.4 Section in two intersecting planes, one shown revolved into the plane of projection (see Fig. 10.14).

10.2.5.5 In the case of parts of revolution containing regularly spaced details that require to be shown in

section, but are not situated in the cutting plane, provided that no ambiguity can arise, such details may be depicted by rotating them into the cutting plane (see Fig. 10.15) but some indication of having done so is recommended.

10.2.6 Sections Revolved in the Relevant View or Removed Sections

10.2.6.1 Cross-sections may be revolved in the relevant view or removed.

10.2.6.2 When revolved in the relevant view, the outline of the section shall be drawn with continuous narrow lines (01.1) and further identification is not necessary (see Fig. 10.16).

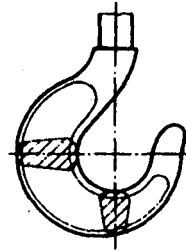


FIG. 10.16

10.2.6.3 When removed, the outline of the section shall be drawn with continuous wide lines (01.2). The removed section may be placed:

- either near to and connected with the view by a long dashed dotted narrow line (04.1) [see Fig. 10.17 (A)].
- or in a different position and identified in the conventional manner as in 10.2.4 by designation [see Fig. 10.17 (B)].

10.2.7 Half Sections

Symmetrical parts may be drawn half in full view and half in section (see Fig. 10.18).

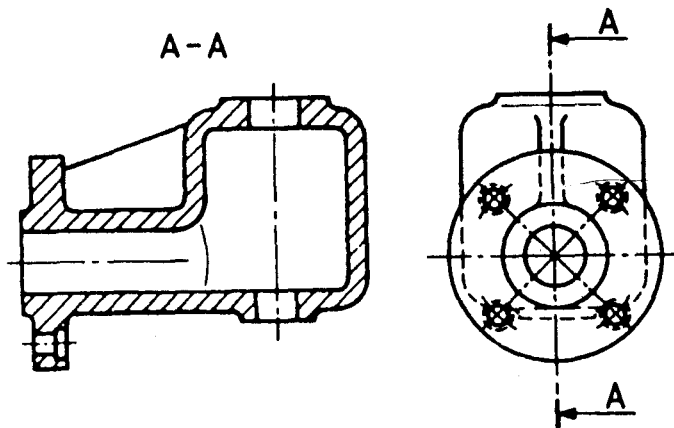


FIG. 10.15

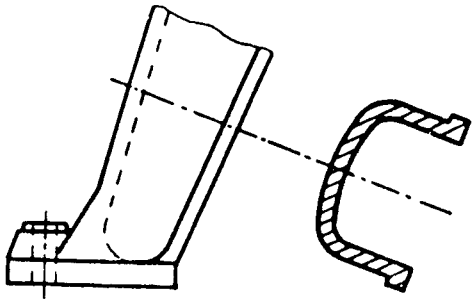


FIG. 10.17A

10.2.8 Local Section

A local section may be drawn if a complete or half section is not convenient. The local break can be shown by either a continuous narrow freehand line (01.1) (see Fig. 10.19) or by continuous narrow straight line with zigzag (01.1).

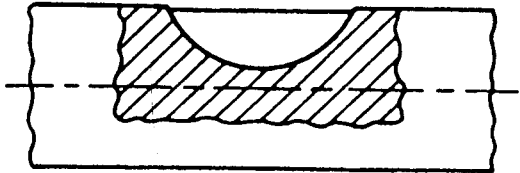


FIG. 10.19

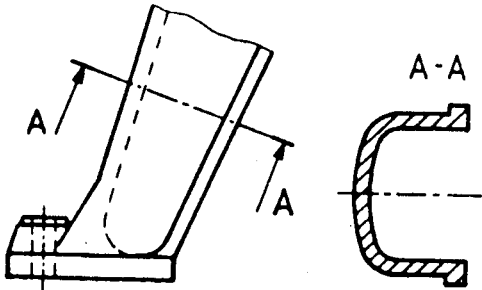


FIG. 10.17B

10.2.9 Arrangement of Successive Sections

Successive sections may be arranged in a manner similar to the examples shown in Fig. 10.20 to 10.22 as convenient for the layout and understanding of the drawing.

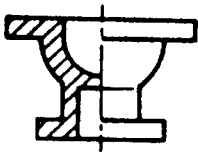


FIG. 10.18

10.3 Other Conventions

10.3.1 Adjacent Parts

Where their representation is necessary, parts adjacent to an object shall be drawn with long dashed double dotted narrow lines (05.1). The adjacent part shall not hide the principal part, but may be hidden by the latter (see Fig. 10.23).

Adjacent parts in sections shall not be hatched.

10.3.2 Intersections

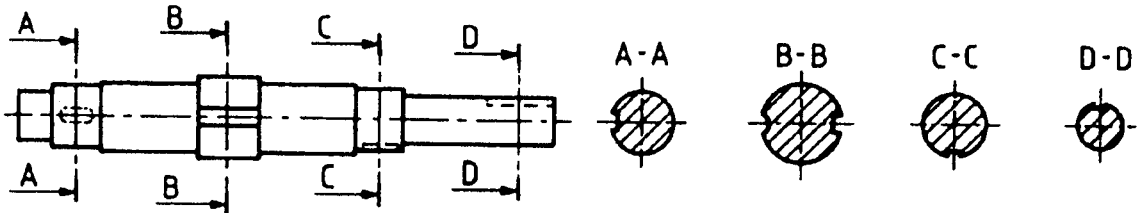


FIG. 10.20

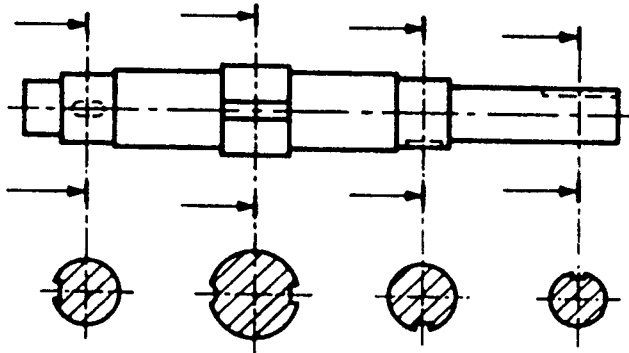


FIG. 10.21

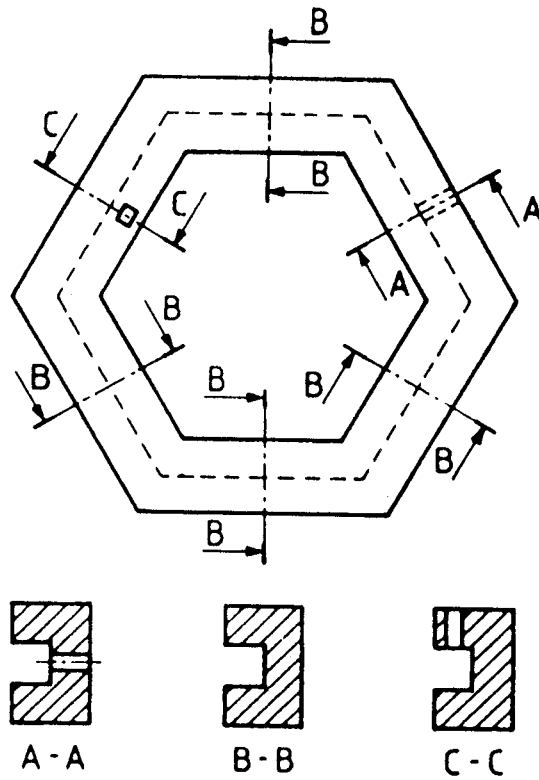


FIG. 10.22

10.3.2.1 True intersections

True geometric intersection lines shall be drawn with continuous wide lines (01.2) when visible, or with dashed narrow or dashed wide line (02.1 or 02.2) when hidden (see Fig. 10.24).

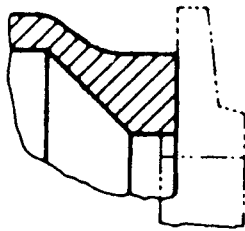


FIG. 10.23

10.3.2.2 Imaginary intersections

Imaginary intersection lines (such as fillets or rounded corners) may be indicated in a view by means of continuous narrow lines (01.1), not touching the outlines (see Fig. 10.25).

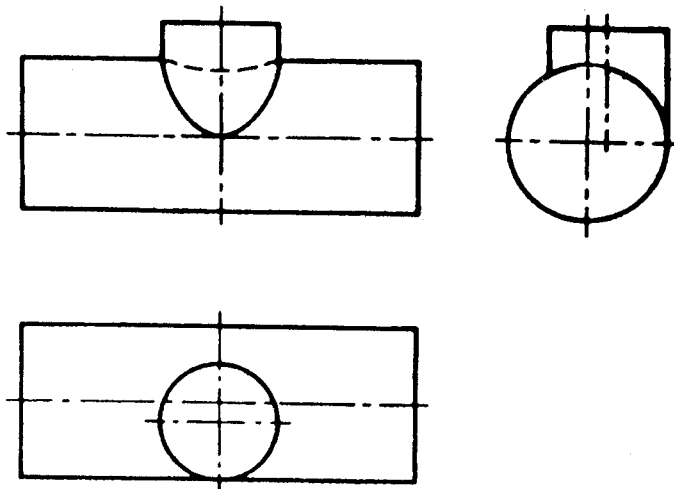


FIG. 10.24

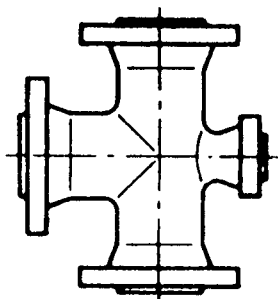


FIG. 10.25

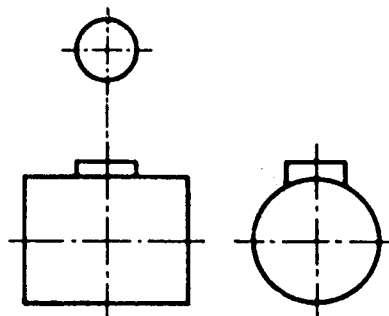


FIG. 10.27

10.3.2.3 Simplified representation of intersections

Simplified representations of true geometric or imaginary intersection lines may be applied at intersections:

- a) between two cylinders: the curved lines of intersection are replaced by straight lines (see Fig. 10.26, 10.27 and 10.29).
- b) between a cylinder and a rectangular prism: the displacement of the straight line of intersection is omitted (see Fig. 10.28 and 10.30).

As the difference in size between the intersecting parts increases, the simplified representation (see Fig. 10.26 to 10.30) only gives a better approach to a real intersection, provided that the axes of the intersecting parts are both mutually perpendicular and intersect, or nearly so.

NOTE — This simplified representation should be avoided if it affects the comprehensibility of the drawing.

10.3.3 Conventional Representation of Square Ends and Openings

10.3.3.1 Square ends on shafts

In order to avoid drawing a supplementary view or section, square ends (see Fig. 10.31) or tapered square

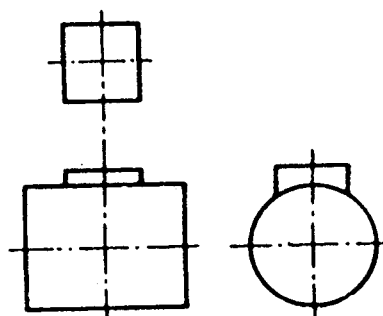


FIG. 10.28

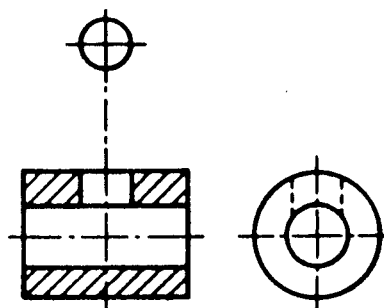


FIG. 10.29

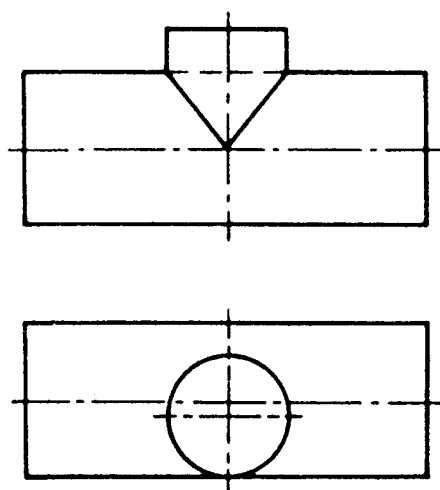


FIG. 10.26

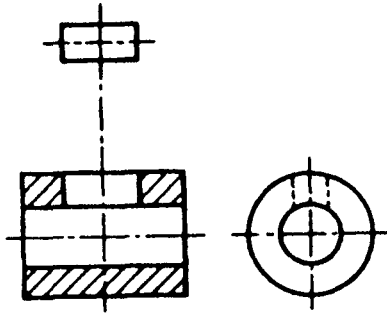


FIG. 10.30

ends on shafts (see Fig. 10.32) may be indicated by diagonals drawn as continuous narrow lines (01.1).

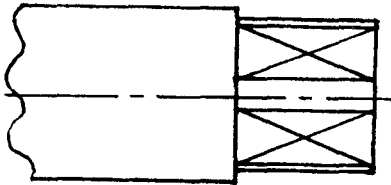


FIG. 10.31

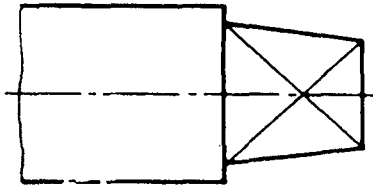


FIG. 10.32

10.3.3.2 Square and rectangular openings

In order to indicate an opening in a flat part in frontal view, without aid of additional sections, this opening may be shown by drawing its diagonals in continuous narrow lines (01.1) (see Fig. 10.33).

10.3.4 Parts Located in Front of a Cutting Plane

If, it is necessary to indicate parts located in front of the cutting plane, these parts are to be represented by long dashed double dotted narrow lines (05.1) (see Fig. 10.34).

10.3.5 Views of Symmetrical Parts

10.3.5.1 To save time and space, symmetrical objects may be drawn as a fraction of the whole (see Fig. 10.35 to 10.38).

10.3.5.2 The line of symmetry is identified at its ends by two narrow short parallel lines drawn at right angles to it (see Fig. 10.35, 10.36 and 10.38).

Another method is to show the lines representing the object extending a little beyond the line of symmetry (see Fig. 10.37). In this case, the short parallel lines may be omitted.

NOTE — In the application of this practice, it is essential that due care is taken to avoid loss of understanding of the drawing.

10.3.6 Interrupted Views

In order to save space, it is permissible to show only those portions of a long object which are sufficient for its definition. The limits of parts retained are shown as for partial views (see 8B.3.9), and the portions are drawn close to each other (see Fig. 10.39 and 10.40).

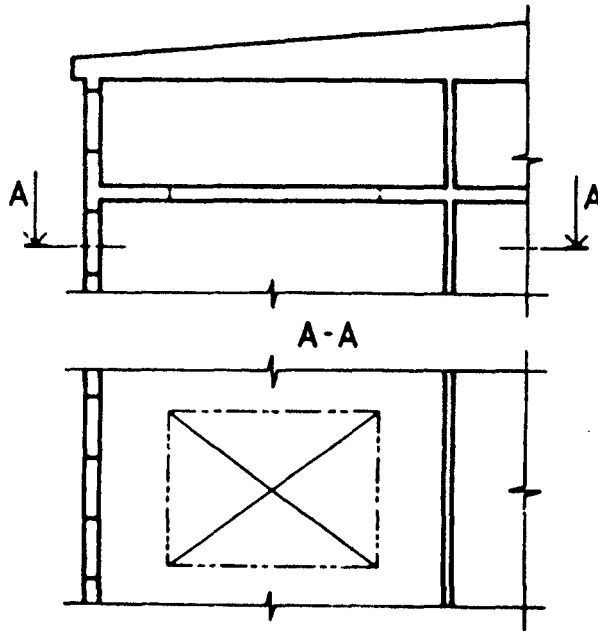


FIG. 10.33

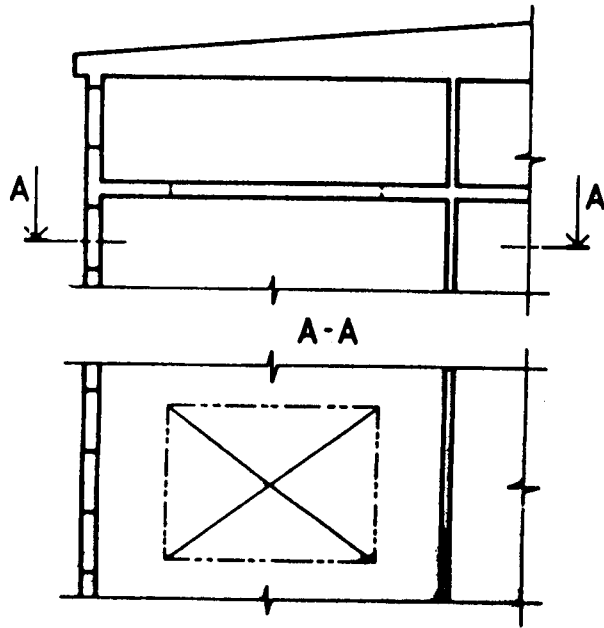


FIG. 10.34

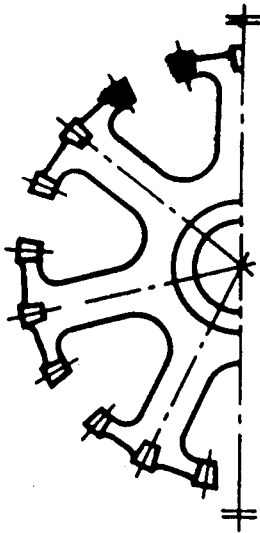


FIG. 10.35

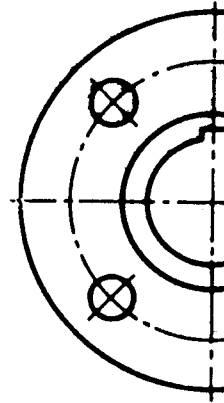


FIG. 10.37

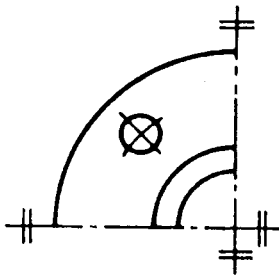


FIG. 10.36

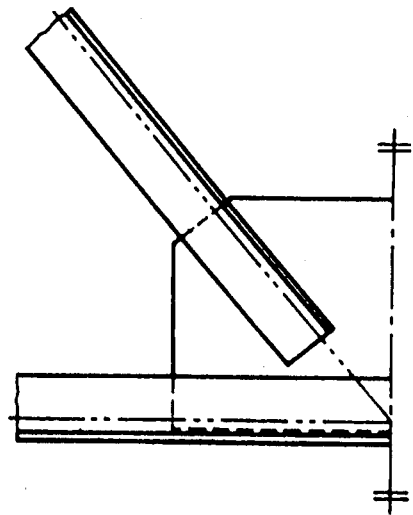


FIG. 10.38

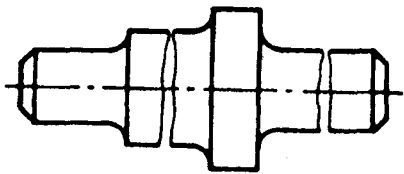


FIG. 10.39

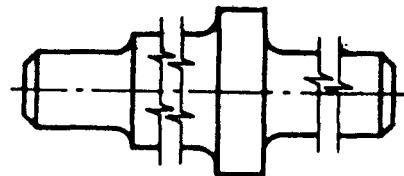


FIG. 10.40

10.3.7 Simplified Representation of Repetitive Features

The presentation of repetitive features may be simplified as shown in Fig. 10.41 and 10.42.

NOTE — In all cases, the number and kind of repetitive features should be defined by dimensioning or by a note.

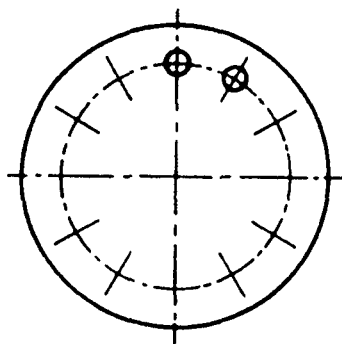


FIG. 10.41

10.3.8 Elements on a Larger Scale

10.3.8.1 In cases where the scale is so small that details of the feature cannot be shown or dimensioned, the feature of the part may be framed by a continuous narrow line (01.1) and identified by a capital letter [see Fig. 10.43 (A)].

10.3.8.2 The relevant feature is then drawn to a stated larger scale accompanied by its identification letter [see Fig. 10.43 (B)].

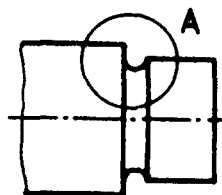


FIG. 10.43A

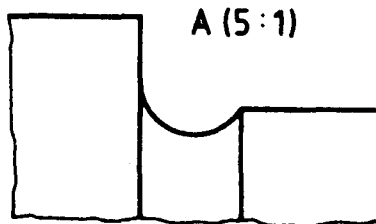


FIG. 10.43B

10.3.9 Initial Outlines

When it is necessary to depict the initial outlines of a part prior to forming, the initial outline shall be indicated by long dashed double dotted narrow lines (05.1) (see Fig. 10.44).

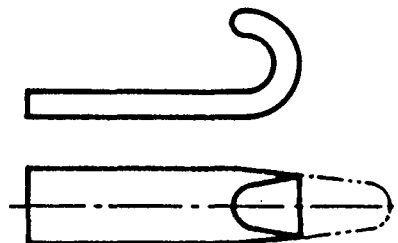


FIG. 10.44

10.3.10 Use of Colours

The use of colours on technical drawings is not recommended. If, it is essential for clarity to use colours, then their meanings shall be clearly shown on the drawing or in other relevant documents.

10.3.11 Transparent Objects

All objects made of transparent material should be drawn as non-transparent.

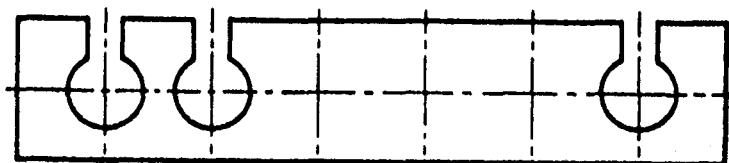


FIG. 10.42

SECTION 11A CONVENTIONAL REPRESENTATION OF SCREW THREADS AND THREADED PARTS — GENERAL CONVENTIONS

[Based on IS 10715 (Part 1) : 1999/ISO 6410-1 : 1993]

11A.1 Scope

This section specifies methods for representing screw threads and threaded parts on technical drawings.

11A.2 Representation

11A.2.1 Detailed Representation of Threads

In certain types of technical product documentation (for example, publications, user manuals, etc) the detailed representation of a thread either in a side view or in a section (see Fig. 11A.1 to 11A.3) may be needed to illustrate single or assembled parts. Neither pitch nor profile of the threads need usually be drawn exactly to scale.

In technical drawings, the detailed representation of threads (see Fig. 11A.1 to 11A.3) should only be used if absolutely necessary and whenever possible the helix should be represented by straight lines (see Fig. 11A.2).

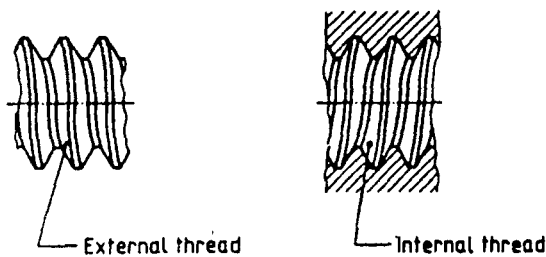


FIG. 11A.1

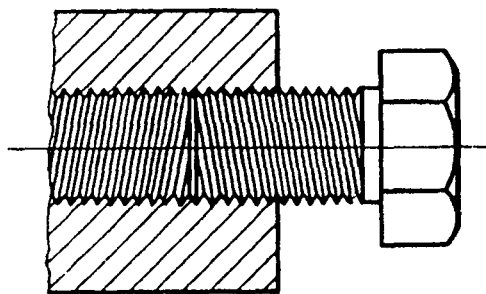


FIG. 11A.2

11A.2.2 Conventional Representation

Normally, by convention, the representation of threads and threaded parts in all types of technical drawings is simplified as shown in Fig. 11A.4 to 11A.7.

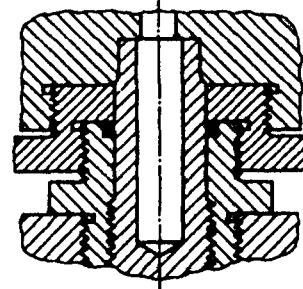


FIG. 11A.3

11A.2.2.1 Views and sections of screw threads

For visible screw threads in side views and sections, the crests¹⁾ of threads shall be defined by a continuous wide line (01.2), and the roots²⁾ of threads by a continuous narrow line (01.1), as shown in Fig. 11A.4 to 11A.13.

The space between the lines representing the crest and root of the thread should approximate as closely as possible the depth of the thread, but, in all cases, this spacing shall be not less than

- twice the thickness of the wide line, or
- 0.7 mm,

whichever is the larger.

NOTE — In certain cases, for example, computer-aided draughting,

- a distance of 1.5 mm for threads of nominal diameter $d \geq 8$ mm is generally acceptable;
- a simplified representation is recommended for threads of nominal diameter $d \leq 6$ mm [see IS 10715 (Part 3)].

11A.2.2.2 End view of screw threads

On an end view of a screw thread, the thread roots shall be represented by a portion of a circle, drawn with a continuous narrow line (01.1) approximately equal to three-quarters of the circumference (see Fig. 11A.4 and 11A.5), preferably open in the right-hand upper quadrant. The wide line representing the chamfer circle is generally omitted on the end view (see Fig. 11A.4 and 11A.5).

NOTE — The portion of the circle may also have any other position relative to the intersecting axes (see Fig. 11A.6).

¹⁾ 'Crest' normally refers to the major diameter for external threads and to the minor diameter for internal threads.

²⁾ 'Root' normally refers to the minor diameter for external threads and to the major diameter for internal threads.

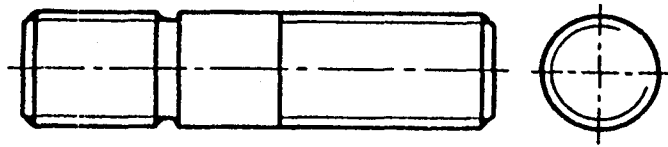


FIG. 11A.4

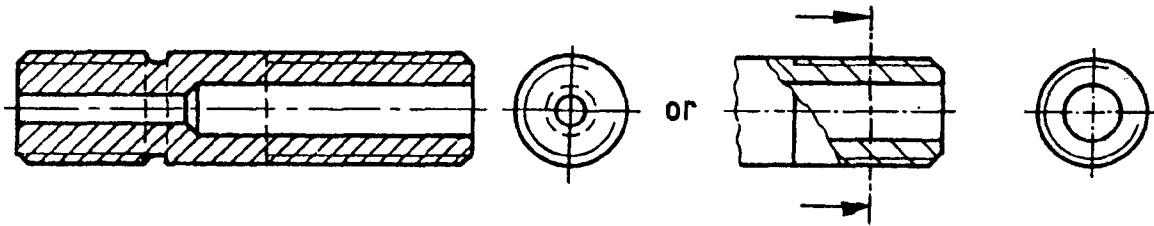


FIG. 11A.5

11A.2.2.3 Hidden screw threads

Where it is necessary to show hidden screw threads the crests and the roots shall be represented by dashed narrow lines (02.1), as shown in Fig. 11A.7.

11A.2.2.4 Hatching of sections of threaded parts

For threaded parts shown in section, hatching shall extend to the line defining the crests of the threads (see Fig. 11A.5 to 11A.8).

11A.2.2.5 Limit of length of full depth thread

The limit of the length of full depth thread

- shall be shown, if visible, by a continuous wide line (01.2)
- may be shown, if hidden, by a dashed line (02.1)

These limit lines shall terminate at the lines defining the major diameter of the thread (see Fig. 11A.4, 11A.8 to 11A.11 and 11A.13).

11A.2.2.6 Thread run-outs

Thread run-outs are beyond the effective ends of the thread except for the end of studs.

They shall be represented by a continuous inclined narrow line (01.1) if functionally necessary (see Fig. 11A.8) or for dimensioning (see Fig. 11A.13). However it is allowed not to represent the run-out wherever possible (see Fig. 11A.4, 11A.5 and 11A.7).

11A.2.3 Assembled Threaded Parts

The conventions specified in 11A.2.2 apply also to assemblies of threaded parts. However, externally threaded parts shall always be shown covering internally threaded parts and shall not be hidden by them (see Fig. 11A.8 and Fig. 11A.10). The wide line

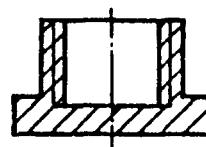


FIG. 11A.6

representing the limit of the useful length of the internal screw thread shall be drawn to the root of the internal thread (see Fig. 11A.8 and Fig. 11A.9).

11A.3 Indication and Dimensioning of Threaded Parts

11A.3.1 Designation

The type of screw thread and its dimensions shall be indicated by means of the designation specified in the relevant Indian Standards for threads.

When indicating the designation on technical drawings, the description block as well as the Indian Standard block shall be omitted.

In general, the screw thread designations covers

- the abbreviation of the kind of thread (standardized symbol, for example, M, G, Tr, HA, etc.);
 - the nominal diameter or size (for example, 20; 1/2; 40, 4.5; etc.);
- and, if necessary,
- the lead (*L*), in mm;
 - the pitch (*P*), in mm;
 - the direction of lead (see 11A.3.4);

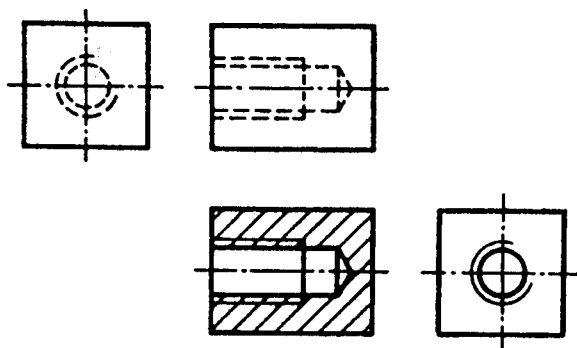


FIG. 11A.7

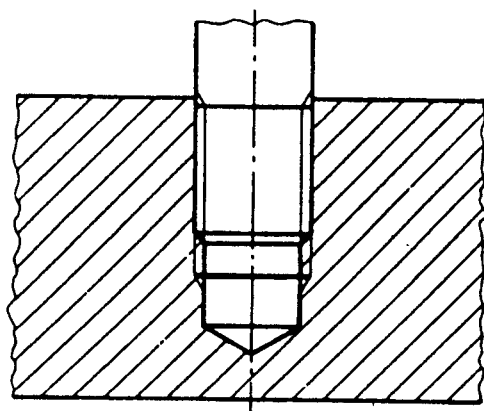


FIG. 11A.8

- thread engagement (S = short, L = long, N = normal);
- the number of starts.

Examples

- a) M20 × 2 – 6G/6h – LH
- b) M 20 × L3 – P1.5 – 6H – S
- c) G 1/2 A
- d) Tr 40 × 7
- e) HA 4.5

11A.3.2 Dimensioning

11A.3.2.1 The nominal diameter, *d*, always refers to the crest of the external thread (see Fig. 11A.11 and 11A.13) or the root of the internal thread (see Fig. 11A.12).

The dimension of the thread length normally refers to the length of the full depth thread (see Fig. 11A.11) unless the run-out is functionally necessary (for example, studs) and therefore specifically drawn (see Fig. 11A.8 and 11A.13).

11A.3.3 Thread Length and Blind Hole Depth

It is generally necessary to dimension the length of thread but the blind hole depth may usually be omitted.

The need for indicating the blind hole depth depends mostly on the part itself and the tool used for threading. When the dimension of the hole depth is unspecified,

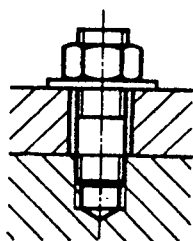


FIG. 11A.9

as well as additional indications, such as
 — the tolerance class according to the relevant Indian Standard;

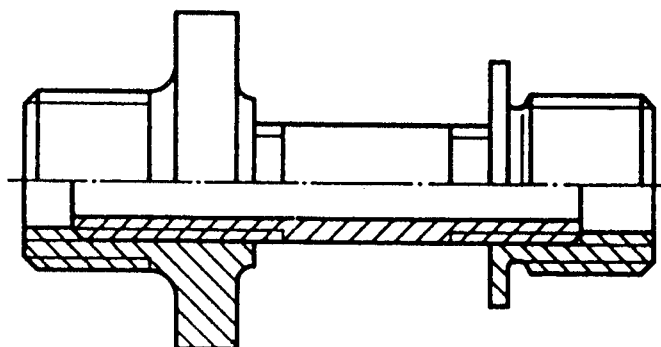


FIG. 11A.10

it shall be depicted as being 1.25 times that of the thread length (see Fig. 11A.14). A short designation as shown in Fig. 11A.15 may also be used.

11A.3.4 Indication of Direction of Lead

Right-hand threads need not be denoted in general. Left-hand threads shall be denoted by adding the abbreviation LH to the thread designation. Right-hand and left-hand threads on the same part shall be denoted, in every case. Right-hand threads shall be denoted, if necessary, by adding the abbreviation 'RH' to the thread designation.

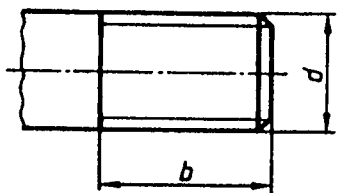


FIG. 11A.11

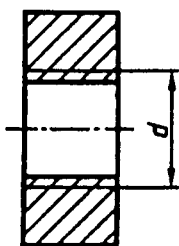


FIG. 11A.12

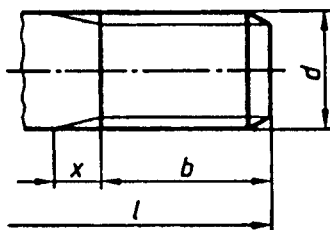


FIG. 11A.13

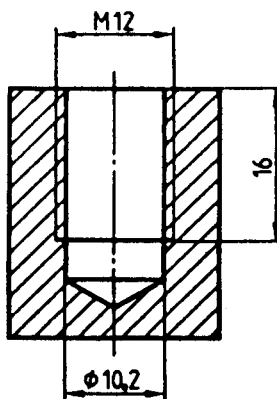


FIG. 11A.14

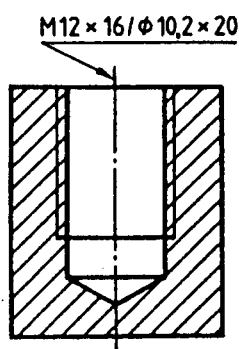


FIG. 11A.15

SECTION 11B CONVENTIONAL REPRESENTATION OF SCREW THREADS AND THREADED PARTS — SIMPLIFIED REPRESENTATION

[Based on IS 10715 (Part 3) : 1999/ISO 6410-3 : 1993]

11B.1 Simplified Representation

11B.1.1 General

In simplified representation only essential features shall be shown. The degree of simplification depends on the kind of object represented, the scale of the drawing and the purpose of the documentation.

Therefore, the following features shall not be drawn in simplified representations of threaded parts:

- edges of chamfers of nuts and heads;
- thread run-outs;
- the shape of ends of screws; and
- undercuts.

11B.1.2 Screws and Nuts

When it is essential to show the shapes of screw heads, drive patterns or nuts, the examples of simplified representations shown in Table 11B.1 shall be used. Combinations of features, not shown in Table 11B.1, may also be used. A simplified representation of the opposite (threaded) end view is not necessary.

11B.1.3 Small Diameter Threads

It is permissible to simplify the representation and/or the indication of dimensions if

- the diameter (on the drawing) is ≤ 6 mm, or
- there is a regular pattern of holes or threads of the same type and size.

The designation shall include all necessary features normally shown in a conventional representation and/or dimensioning.

The designation shall appear on a leader line which points to the centre-line of the hole and terminates in an arrowhead (see Fig. 11B.1 to 11B.4).

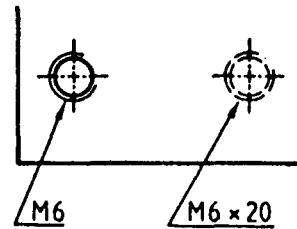


FIG. 11B.1

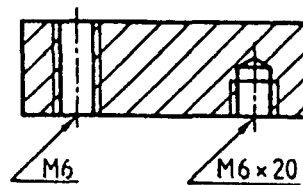


FIG. 11B.2

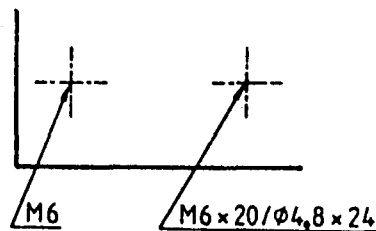


FIG. 11B.3

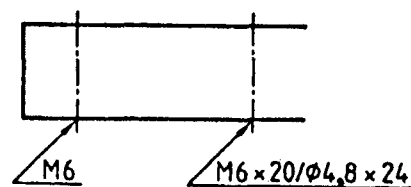
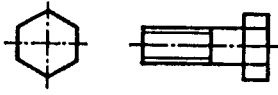
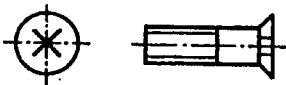
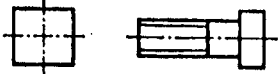
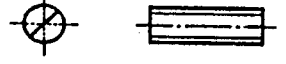


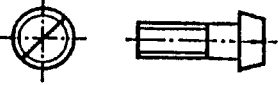
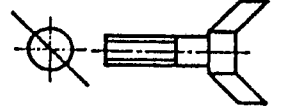
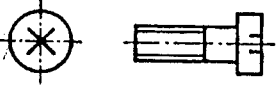
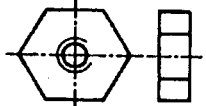
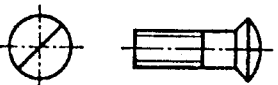
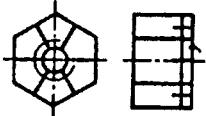

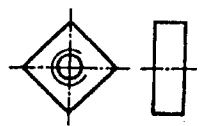

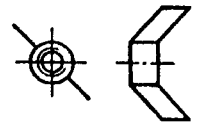


FIG. 11B.4

Table 11B.1 Examples of Simplified Representations
(Clause 11B.1.2)

No.	Designation	Simplified representation	No.	Designation	Simplified representation
1	Hexagon head screw		9	Countersunk screw, cross slot	
2	Square head screw		10	Set screw, slot	
3	Hexagon socket screw		11	Wood and self-tapping screw, slot	
4	Cylinder screw (pan-head type), slot		12	Wing screw	
5	Cylinder screw, cross slot		13	Hexagon nut	
6	Oval countersunk screw, slot		14	Crown nut	
7	Oval countersunk screw, cross slot		15	Square nut	
8	Countersunk screw, slot		16	Wing nut	

SECTION 11C CONVENTIONAL REPRESENTATION OF SPRINGS — SIMPLIFIED REPRESENTATION

[Based on IS 10716 (Part 1) : 1999/ISO 2162-1 : 1993]

11C.1 Scope

This section gives rules for the simplified representation of compression, extension, torsion, disc, spiral and leaf springs on technical drawings.

11C.2 General

In simplified representations, springs are represented as follows:

- Coiled wire springs: by a line following the axis of the spring wire.
- Other types of springs: by lines showing the characteristics of the respective type of springs and their elements.



The representations shown are examples only.

11C.3 Helical Compression Springs

The following requirements shall be applied for the indication of the geometrical characteristics of wire-made springs on a simplified representation (see Table 11C.1).

a) *Cross-section of the Material*

Cylindrical — The appropriate graphical symbol in accordance with Section 17 need not be indicated.

Other than cylindrical — The appropriate graphical symbol in accordance with Section 17 shall be indicated (for example, , ).

b) *Direction of Helix*

Right-hand — assumed as normal and the designation RH need not be indicated.

Left-hand — exceptional and the designation LH¹⁾ shall be indicated.

¹⁾ In accordance with the rules given for the indication of left-hand screw threads (see ISO 5864-1993).

c) *Shape of Ends*

Ground — No indication is necessary

Other than ground — The type shall be specified on the drawing, with dimensions if necessary.

11C.4 Helical Extension Springs

The requirements for the indication of the cross-section of the material and direction of helix are identical to those given in 11C.3.

The shape of the ends shall be specified on the drawing, with dimensions if necessary.

The spring and its ends usually have the same diameter.

11C.5 Torsion Springs

The requirements for the indication of the direction of helix and the cross-section of the material for No. 1 in Table 11C.3 are identical to those given in 11C.3. For No. 2 and 3 in Table 11C.3, the cross-section of the material shall be indicated.

The shape of the ends shall be specified on the drawing, with dimensions if necessary.

11C.6 Disc Springs (Belleville) (see Table 11C.4)

11C.7 Spiral Springs

The cross-section of the material shall be indicated (see example in No. 1 in Table 11C.5). In cases No. 1 and 2 in Table 11C.5; the shape of the ends needs to be indicated.

11C.8 Leaf Springs (see Table 11C.6)

Table 11C.1 Helical Compression Springs
(Clause 11C.3)

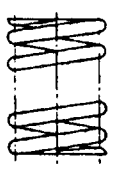
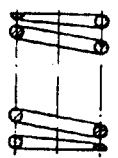
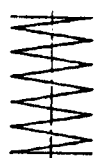
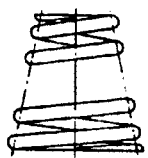
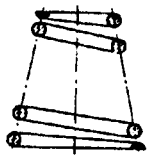
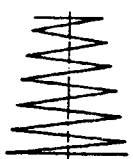
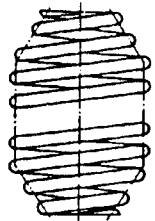
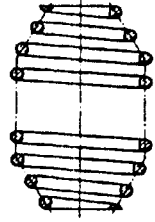
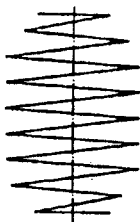
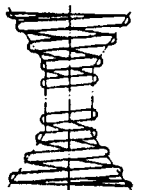
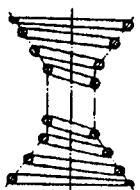
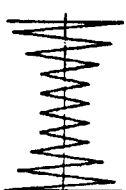
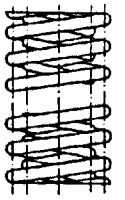
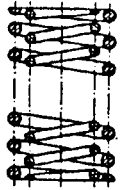
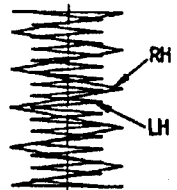
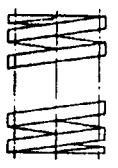
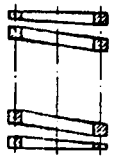
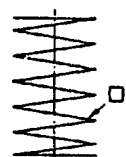
No.	Type of spring	Representation		
		View	Section	Simplified
1	Cylindrical helical compression spring			
2	Conical helical compression spring			
Combinations of cylindrical (1) and conical (2) helical compression springs.				
3	Double-conical helical compression spring Barrel spring			
4	Double-conical helical compression spring Waisted spring			
5	Spring nest of, for example, two cylindrical helical compression springs			
6	Cylindrical helical compression spring of material having square cross-section			

Table 11C.1 — (Concluded)

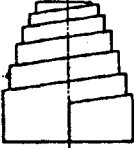


No.	Type of spring	Representation		
		View	Section	Simplified
7	Conical helical compression spring of strip having rectangular cross-section Volute spring			

Table 11C.2 Helical Extension Springs
(Clause 11C.4)

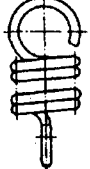
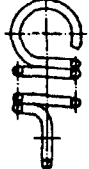

No.	Type of spring	Representation		
		View	Section	Simplified
1	Cylindrical helical extension spring			

Table 11C.3 Torsion Springs
(Clause 11C.5)

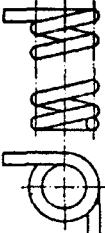
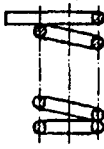
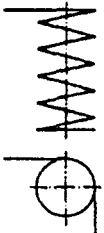
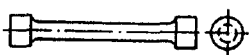

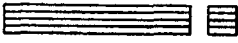
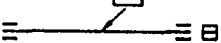
No.	Type of spring	Representation		
		View	Section	Simplified
1	Cylindrical helical torsion spring			
		View		Simplified
2	Torsion bar spring having circular cross-section			
3	Stacked laminated torsion bar spring of strips having rectangular cross-section			

Table 11C.4 Disc Springs
(Clause 11C.6)

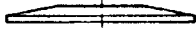


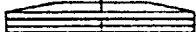
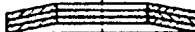

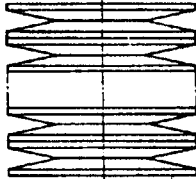
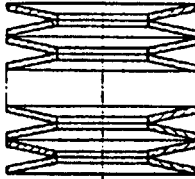
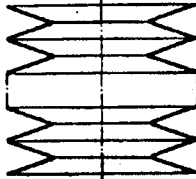
No.	Type of spring	Representation		
		View	Section	Simplified
1	Disc spring, single			
2	Multi-disc spring (disc laminated in parallel)			
3	Multi-disc spring (disc laminated in series) Disc spring column			

Table 11C.5 Spiral Springs
(Clause 11C.7)


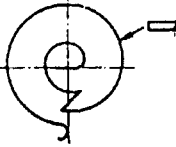
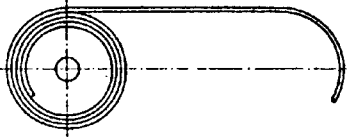
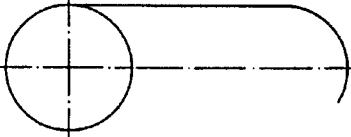
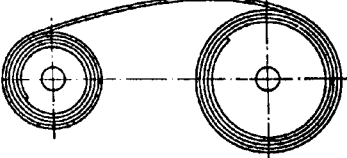
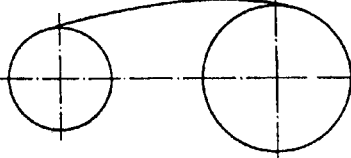
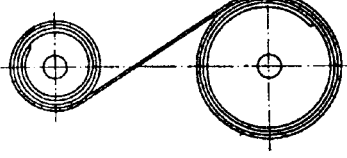
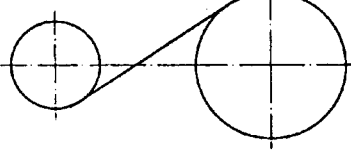
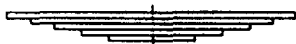
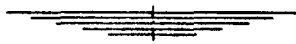





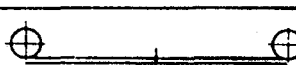
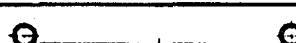








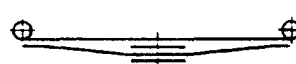
No.	Type of spring	Representation	
		View	Simplified
1	Spiral spring of strip having rectangular cross-section		
2	Constant force extension spring		
3	Constant force spring — A-Motor		
4	Constant force spring — B-Motor		

Table 11C.6 Leaf Springs
(Clause 11C.8)

No.	Type of spring	Representation	
		View	Simplified
1	Laminated leaf spring without eyes		
2	Laminated leaf spring with eyes		
3	Laminated leaf spring with eyes and helper spring		
4	Laminated leaf spring with eyes and auxiliary spring		
5	Parabolic single-leaf spring with eyes		
6	Parabolic multi-leaf spring without eyes		
7	Parabolic multi-leaf spring with eyes		
8	Parabolic multi-leaf spring with eyes and helper spring		
9	Parabolic multi-leaf spring with eyes and auxiliary spring		

SECTION 11D CONVENTIONAL REPRESENTATION OF GEARS ON TECHNICAL DRAWINGS

[Based on IS 10717 : 1983/ISO 2203 : 1973]

11D.1 Conventional Representation of Gears on Technical Drawings

This section deals with the conventional representation of toothed portion of gears including worm gearing and chain wheels. It is applicable to detail drawings and assembly drawings. As a fundamental principle, a gear is represented (except in axial section) as a solid part without teeth, but with the addition of the pitch surface in a thin long chain line.

11D.2 Detail Drawings (Individual Gears)

11D.2.1 Contours and Edges

Represent the contours and the edges of each gear (see Fig. 11D.1, 11D.2 and 11D.3), as if they were:

- a) in an unsectioned view, a solid gear bounded by the tip surface.
- b) in an axial section, a spur gear having two diametrically opposed teeth, represented unsectioned, even in the case of a gear that does not have spur teeth or that has an odd number of teeth.

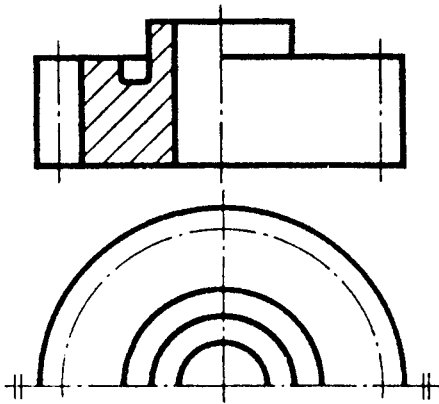


FIG. 11D.1

11D.2.2 Pitch Surface

Draw the pitch surface with a long dashed double dotted narrow line, even in concealed portions and sectional views, and represent it:

- a) in a projection normal to the axis, by its pitch circle (external pitch circle in the case of a bevel gear and the median pitch circle in the

case of a worm wheel) (see Fig. 11D.1, 11D.2 and 11D.3).

- b) in a projection parallel to the axis, by its apparent contour, extending the line beyond the gear contour on each side (see Fig. 11D.1, 11D.2 and 11D.3).

11D.2.3 Root Surface

As a general rule, do not represent the root surface except in sectional views. However, if it seems helpful to show it also on unsectioned views, always draw it, in this case, as a continuous narrow line (see Fig. 11D.4, 11D.5 and 11D.6).

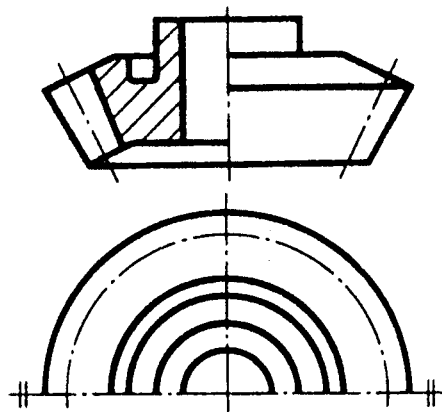


FIG. 11D.2

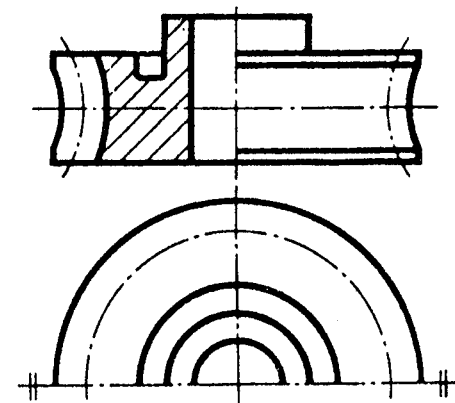


FIG. 11D.3

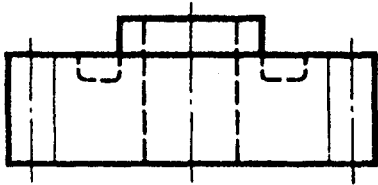


FIG. 11D.4

11D.2.4 Teeth

Specify the teeth profile either by reference to a standard or by a drawing to a suitable scale.

If it is essential to show one or two teeth on the drawing itself (either to define the ends of a toothed portion or rack, or in order to specify the position of the teeth in relation to a given axial plane), draw them as continuous wide lines (see Fig. 11D.5 and 11D.6).

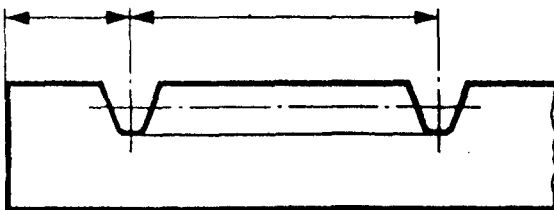


FIG. 11D.5

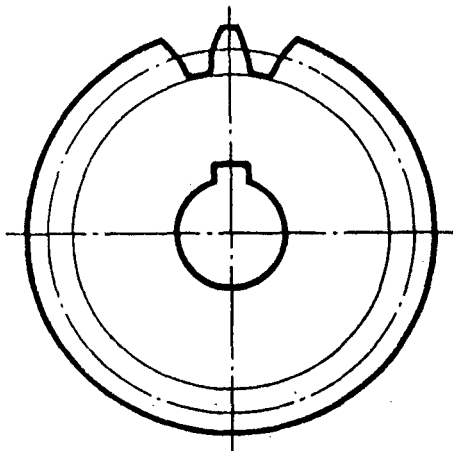


FIG. 11D.6

It is necessary to indicate the direction of the teeth of a gear or rack on the view of the tooth surface in a projection parallel to the gear axes, three continuous

narrow lines (01.1) of the corresponding form and direction should be shown (see Table 11D.1 and Fig. 11D.7).

NOTE — If mating gears are represented, the direction of the teeth should be shown on one gear only.

Table 11D.1 Indication of Direction of Teeth
(Clause 11D.2.4)

Teeth system	Symbol
Helical to the right	
Helical to the left	
Double helical	
Spiral	

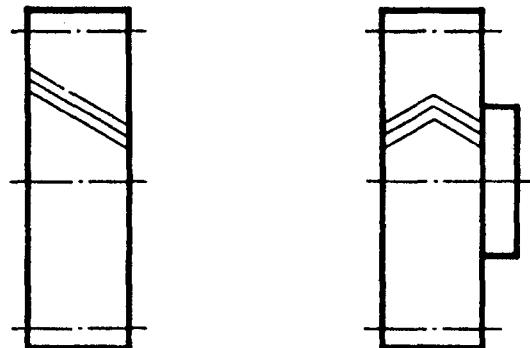


FIG. 11D.7

11D.3 Assembly Drawings (Gear Parts)

11D.3.1 External Engagement of Cylindrical Gears (see Fig. 11D.8)

11D.3.2 Internal Engagement of Cylindrical Gears (see Fig. 11D.9)

11D.3.3 Engagement of Pinion with Rack (see Fig. 11D.10)

11D.3.4 Engagement of Bevel Gears, Axis Intersection at any Angle (see Fig. 11D.11)

11D.3.5 Engagement with Cylindrical Worm, in Cross-section (see Fig. 11D.12)

11D.3.6 Chain Wheels (see Fig. 11D.13)

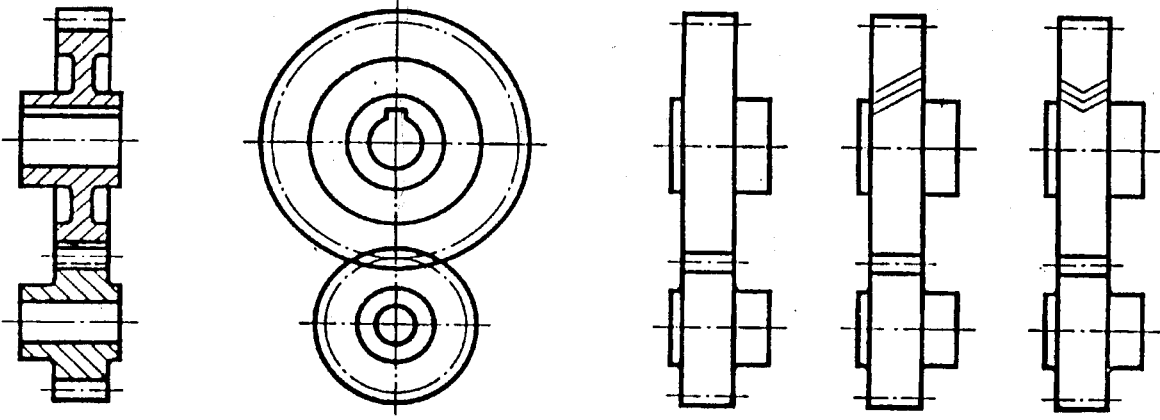


FIG. 11D.8

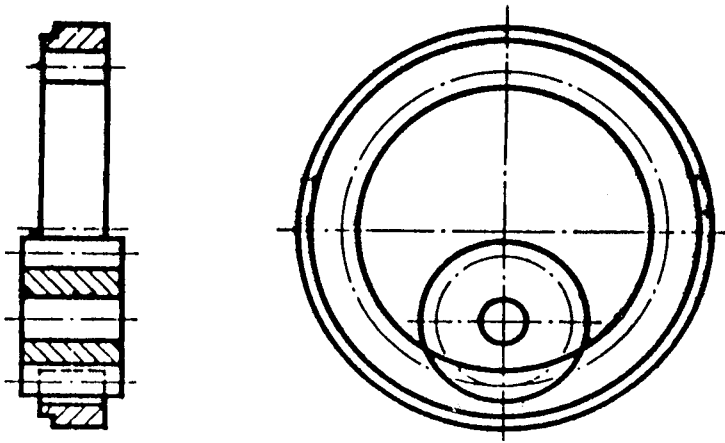


FIG. 11D.9

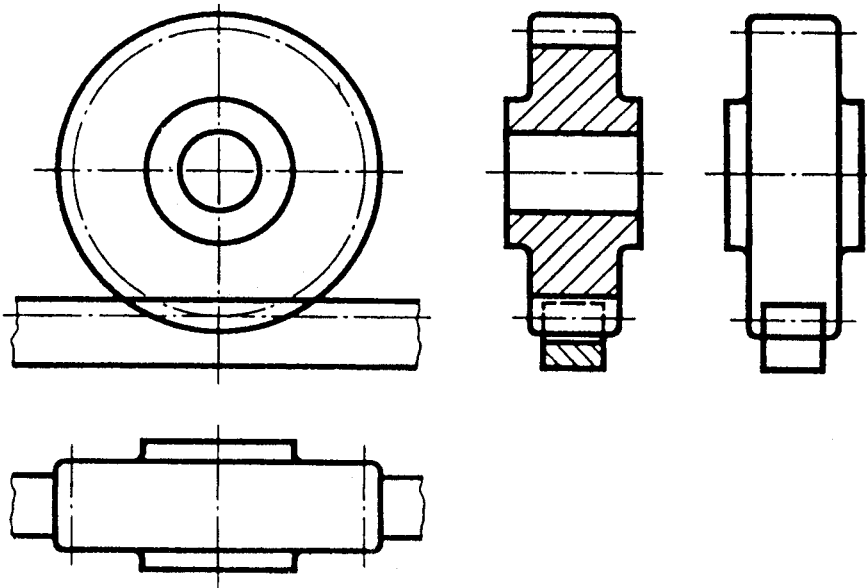


FIG. 11D.10

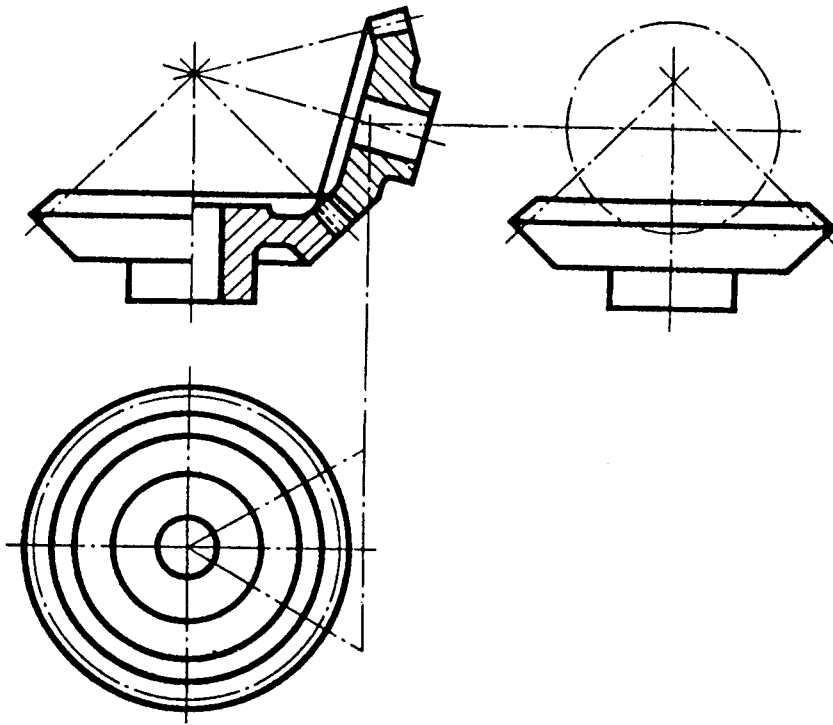


FIG. 11D.11

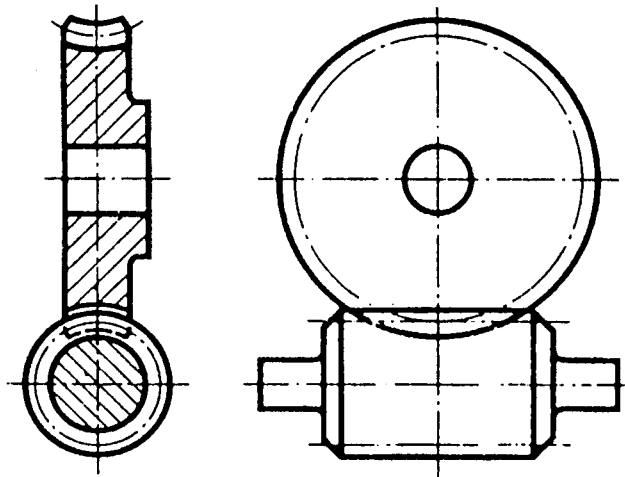


FIG. 11D.12

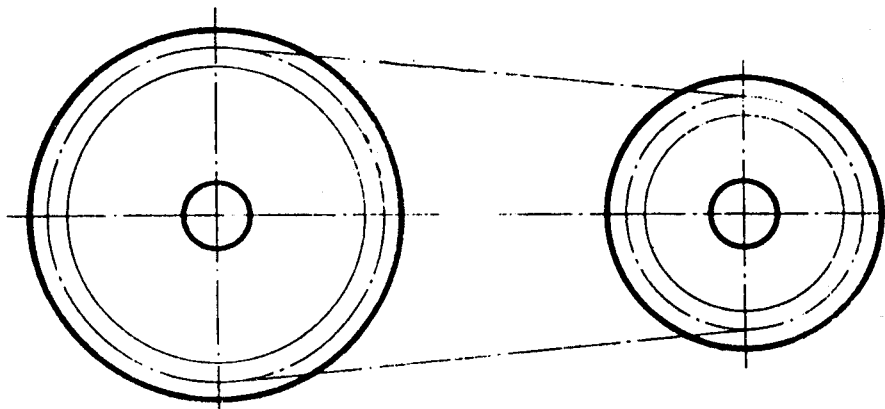


FIG. 11D.13

SECTION 12 GENERAL PRINCIPLES OF DIMENSIONING ON TECHNICAL DRAWINGS

[Based on IS 11669 : 1986/ISO 129 : 1985]

12.1 Scope and Field of Application

12.1.1 This section establishes the general principles of dimensioning applicable in all fields (that is, mechanical, electrical, civil engineering, architecture, etc). It is possible that in some specific technical areas, the general rules and conventions will not cover all the needs of specialized practices adequately. In such cases additional rules may be laid down in standards specific to these areas. However, the general principles of this section shall be followed to facilitate the international exchange of drawings and to ensure the coherence of drawings in a comprehensive system relating to several technical fields.

12.1.2 The figures as shown in this section, merely illustrate the text and are not intended to reflect actual usage. The figures are consequently simplified to indicate only the relevant general principles applicable in any technical field.

12.2 General Principles

12.2.1 Definitions

For the purpose of this section, the following definitions apply.

12.2.1.1 Dimension

A numerical value expressed in appropriate units of measurement and indicated graphically on technical drawings with lines, symbols and notes.

Dimensions are classified according to the following types:

- a) *Functional dimension*
A dimension that is essential to the function of the piece or space (see *F* in Fig. 12.1).
- b) *Non-functional dimension*
A dimension that is not essential to the function of the piece or space (see *NF* in Fig. 12.1).
- c) *Auxiliary dimension*
A dimension given for information purposes only. It does not govern production or inspection operations and is derived from other values shown on the drawing or in related documents. An auxiliary dimension is given in parenthesis and no tolerance applies to it (see *AUX* in Fig. 12.1).

12.2.1.2 Feature

An individual characteristic such as flat surface, a cylindrical surface, two parallel surfaces, a shoulder, a screw thread, a slot, a profile, etc.

12.2.1.3 End product

The complete part ready for assembly or service or a configuration produced from a drawing specification. An end product may also be a part ready for further processing (for example, the product of a foundry or forge) or a configuration needing further processing.

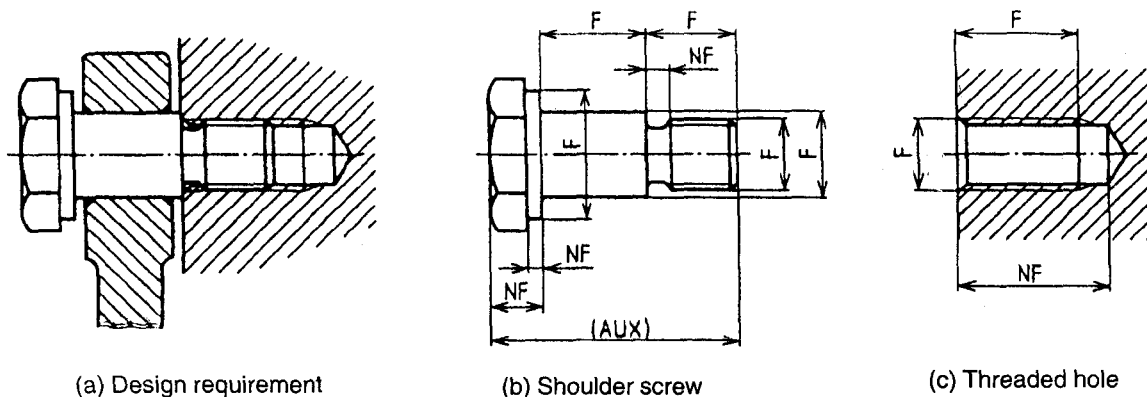


FIG. 12.1 FUNCTIONAL, NON-FUNCTIONAL AND AUXILIARY DIMENSIONS

12.2.2 Application

12.2.2.1 All dimensional information necessary to define a part or a component clearly and completely shall be shown directly on a drawing unless this information is specified in associated documentation.

12.2.2.2 Each feature shall be dimensioned once only on a drawing.

12.2.2.3 Dimensions shall be placed on the view or section that most clearly shows the corresponding features.

12.2.2.4 Each drawings shall use the same unit (for example, millimetres) for all dimensions but without showing the unit symbol. In order to avoid misinterpretation, the predominant unit symbol on a drawing may be shown in a note.

Where other units have to be shown as part of the drawing specification (for example, Nm for torque or kPa for pressure), the appropriate unit symbol shall be shown with the value.

12.2.2.5 No more dimensions than are necessary to define a part or an end product shall be shown on a drawing. No feature of a part or an end product shall be defined by more than one dimension in any one direction. Exception may, however, be made:

- a) where it is necessary to give additional dimensions at intermediate stages of production (for example, the size of a feature prior to carburizing and finishing);
- b) where the addition of an auxiliary dimension would be advantageous.

12.2.2.6 Production processes or inspection methods should not be specified unless they are essential to ensure satisfactory functioning or interchangeability.

12.2.2.7 Functional dimensions should be shown directly on the drawing wherever possible (see Fig. 12.2).

Occasionally indirect functional dimensioning is justified or necessary. In such cases, care must be exercised so that the effect of directly shown functional dimensioning is maintained. Figure 12.3

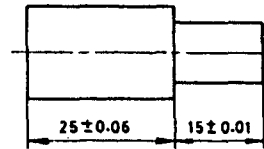


FIG. 12.2 FUNCTIONAL DIMENSIONING

shows the effect of acceptable indirect functional dimensioning that maintains the dimensional requirements established by Fig. 12.2.

12.2.2.8 The non-functional dimensions should be placed in a way which is most convenient for production and inspection.

12.3 Method of Dimensioning

12.3.1 Elements of Dimensioning

The elements of dimensioning include the projection line, dimension line, leader line, dimension line termination, the origin indication, and the dimension itself. The various elements of dimensioning are illustrated in Fig. 12.4 and 12.5.

12.3.2 Projection Lines, Dimension Lines and Leader Lines

Projection lines, dimension lines and leader lines are drawn as continuous narrow lines as shown in Section 6 and as illustrated in Fig. 12.4 and 12.5.

12.3.2.1 Projection lines shall extend slightly beyond the respective dimension line (see Fig. 12.4 and 12.5).

12.3.2.2 Projection lines should be drawn perpendicular to the feature being dimensioned. Where necessary, however, they may be drawn obliquely, but parallel to each other (see Fig. 12.6).

12.3.2.3 Intersecting construction and projection lines shall extend slightly beyond their point of intersection (see Fig. 12.7).

12.3.2.4 In general, projection lines and dimension lines should not cross other lines unless this is unavoidable (see Fig. 12.8).

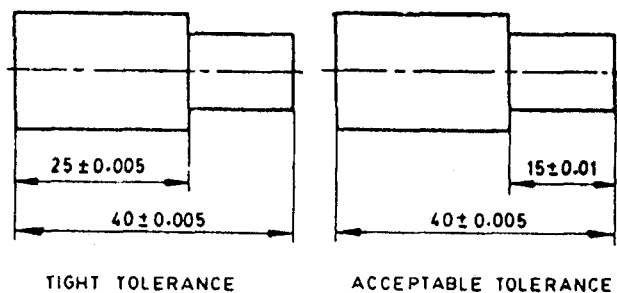


FIG. 12.3 INDIRECT FUNCTIONAL DIMENSIONING

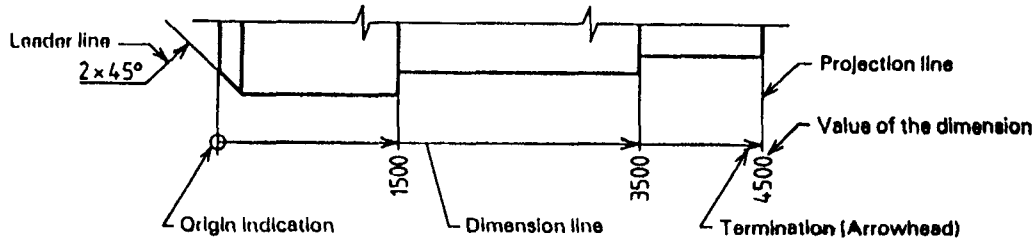


FIG. 12.4

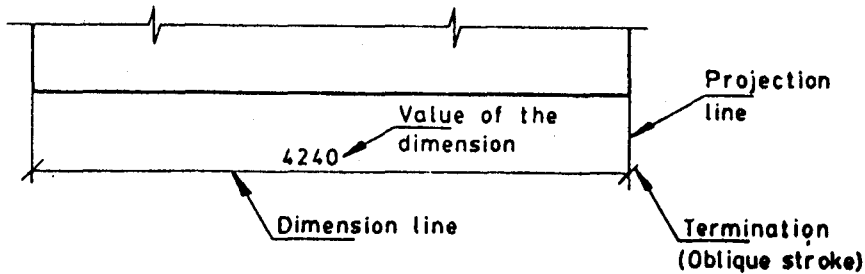


FIG. 12.5

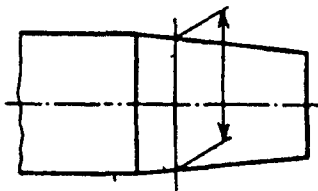


FIG. 12.6

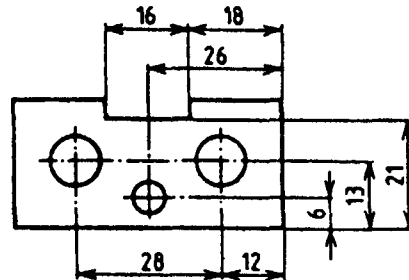


FIG. 12.10

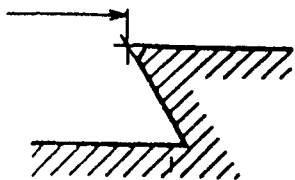


FIG. 12.7

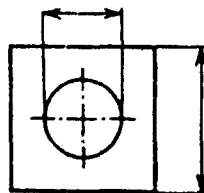


FIG. 12.8

12.3.2.5 A dimension line shall be shown unbroken where the feature to which it refers is shown broken (see Fig. 12.9), except as indicated in 12.3.4.1 Method 2.

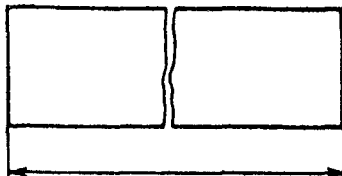


FIG. 12.9

12.3.2.6 Intersecting projection and dimension lines should be avoided. Where unavoidable, however, neither line shall be shown with a break (see Fig. 12.10).

12.3.2.7 A centreline or the outline of a part shall not be used as a dimension line but may be used in place of a projection line (see Fig. 12.10).

12.3.3 Terminations and Origin Indication

Dimension lines shall show distinct terminations (that is either arrowheads or oblique strokes), or, where applicable, an origin indication.

12.3.3.1 Two dimension line terminations (see Fig. 12.11) and an origin indication (see Fig. 12.12) are specified in this section. They are:

- the arrowhead, drawn as short lines forming barbs at any convenient included angle between 15° and 90°. The arrowhead may be open, closed, or closed and filled in [see Fig. 12.11 (a)];
- the oblique stroke, drawn as a short line inclined at 45° [see Fig. 12.11 (b)];
- the origin indication, drawn as a small open circle of approximately 3 mm in diameter (see Fig. 12.12).

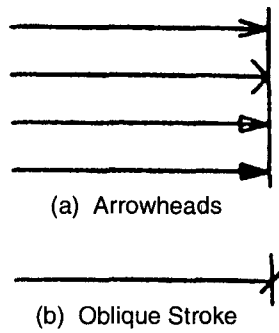


FIG. 12.11



FIG. 12.12

12.3.3.2 The size of the terminations shall be proportionate to the size of drawing on which they are used but not larger than is necessary to read the drawing.

12.3.3.3 One style of arrowhead termination only shall be used on a single drawing. However, where space is too small for an arrowhead, the oblique stroke or a dot may be substituted (see Fig. 12.24).

12.3.3.4 Arrowhead terminations shall be shown within the limits of the dimension line where space is available (see Fig. 12.13). Where space is limited, the arrowhead termination may be shown outside the intended limits of the dimension line that is extended for that purpose (see Fig. 12.14).



FIG. 12.13



FIG. 12.14

12.3.3.5 Only one arrowhead termination, with its point on the arc end of the dimension line, shall be used where a radius is dimensioned (see Fig. 12.15). The arrowhead termination may be either on the inside or on the outside of the feature outline (or its projection line) depending upon the size of the feature.

12.3.4 Indicating Dimensional Values on Drawings

- a) Dimensional values shall be shown on drawings in characters of sufficient size to ensure complete legibility on the original drawing as

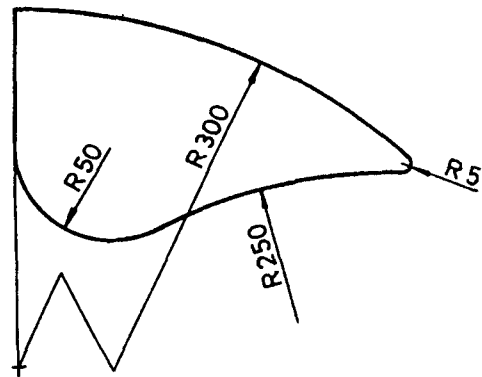


FIG. 12.15

well as on reproductions made from microfilms.

- b) They shall be placed in such a way that they are not crossed or separated by any other line on the drawing.

12.3.4.1 Values shall be indicated on a drawing according to one of the following two methods. Only one method should be used on any one drawing.

Method 1

- a) Dimensional values shall be placed parallel to their dimension lines and preferably near the middle, above and clear of the dimension line (see Fig. 12.16).

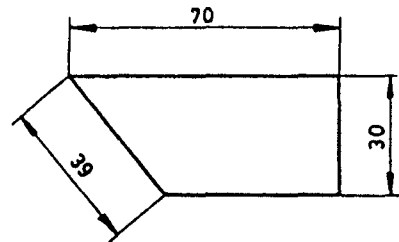


FIG. 12.16

- b) An exception may be made where superimposed running dimensions are used (see 12.4.2.4). However, values shall be indicated so that they may be read from the bottom or from the right-hand side of the drawing. Values on oblique dimension lines shall be oriented as shown in Fig. 12.17.

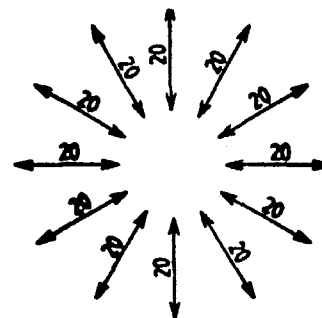


FIG. 12.17

c) Angular dimensional values may be oriented either as in Fig. 12.18 or Fig. 12.19.

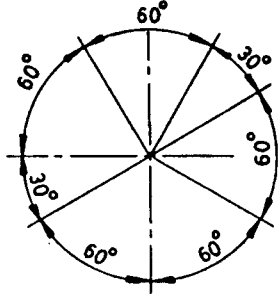


FIG. 12.18

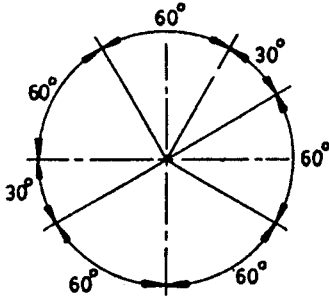


FIG. 12.19

b) Angular dimensional values may be oriented either as in Fig. 12.19 or 12.22.

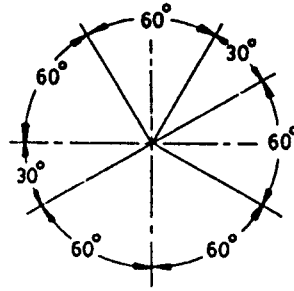


FIG. 12.22

12.3.4.2 The positioning of dimensional values frequently needs adapting to different situations. Therefore, for example, values may be:

- a) closer to a termination to avoid having to follow a long dimension line where only part of the dimension line needs to be shown (see Fig. 12.23).

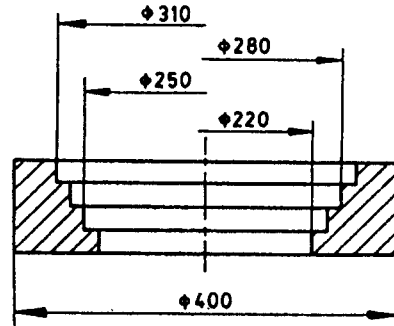


FIG. 12.23

Method 2

- a) Dimensional values shall be indicated so that they may be read from the bottom of the drawing sheet. Non-horizontal dimension lines are interrupted, preferably near the middle so that the value may be inserted (see Fig. 12.20 and 12.21).

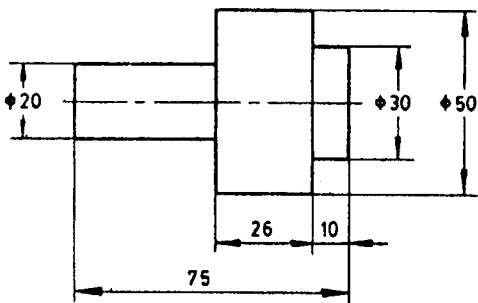


FIG. 12.20

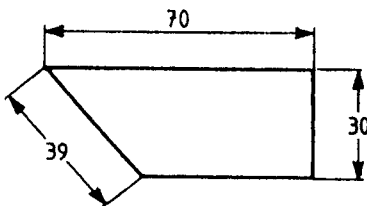


FIG. 12.21

- b) above the extension of the dimension line beyond one of the terminations if space is limited (see Fig. 12.24).
- c) at the end of a leader line which terminates on a dimension line that is too short for dimensional value to be indicated in the usual way (see Fig. 12.24).

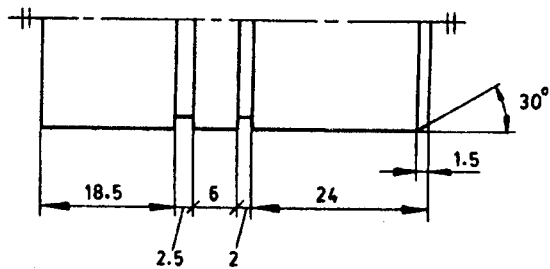


FIG. 12.24

- d) above a horizontal extension of a dimension line where space does not allow placement at

the interruption of a non-horizontal dimension line (see Fig. 12.25).

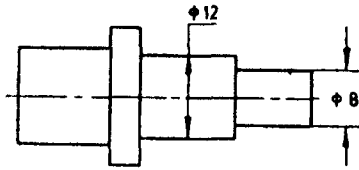


FIG. 12.25

12.3.4.3 Values for dimensions out-of-scale (except where break lines are used) shall be underlined with a straight wide line (see Fig. 12.26).

NOTE — Dimensions out-of-scale can result from a feature size modification where the modification does not warrant an extensive drawing revision to correct the feature scale.

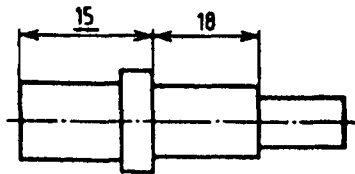


FIG. 12.26

12.3.4.4 The following indications are used with dimensions to show applicable shape identification and to improve drawing interpretation. The diameter and square symbols may be omitted where the shape is clearly indicated. The applicable indication (symbol) shall precede the value for dimension (see Fig. 12.27 to 12.31).

- ϕ : Diameter
- R : Radius
- : Square
- S ϕ : Spherical diameter
- SR : Spherical radius

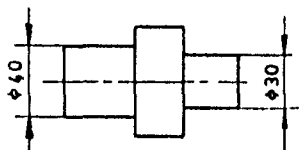


FIG. 12.27

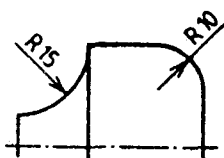


FIG. 12.28

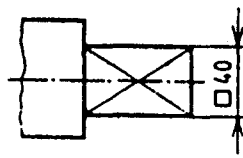


FIG. 12.29

12.4 Arrangement and Indication of Dimensions

The arrangement of dimensioning on a drawing shall indicate clearly the design purpose. Generally, the

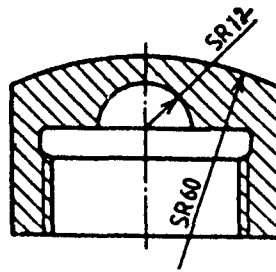


FIG. 12.30

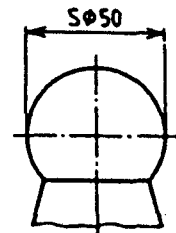


FIG. 12.31

arrangement of dimensions is the result of a combination of various design requirements.

12.4.1 Chain Dimensioning

Chains of single dimensions (see Fig. 12.32) should be used only where the possible accumulation of tolerances does not impinge on the functional requirements of the part. Any termination may be used for chain dimensioning except the 90° arrowhead [see Fig. 12.11(a)].

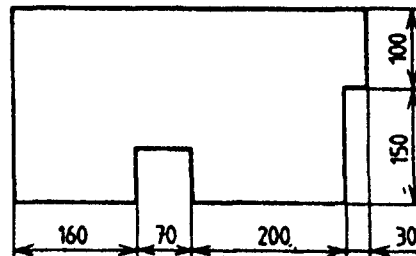


FIG. 12.32

12.4.2 Dimensioning from a Common Feature

12.4.2.1 This method of dimensioning is used where a number of dimensions of the same direction relate to a common origin.

12.4.2.2 Dimensioning from a common feature may be executed as parallel dimensioning or as superimposed running dimensioning.

12.4.2.3 Parallel dimensioning is the placement of a number of single dimension lines parallel one to another and spaced out so that the dimensional value can easily be added in (see Fig. 12.33 and 12.41).

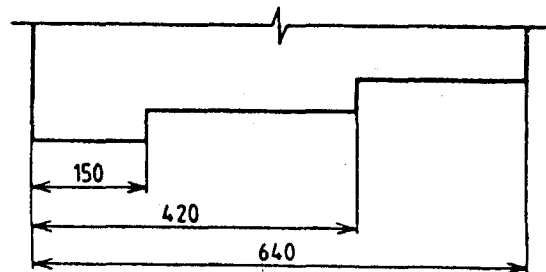


FIG. 12.33

12.4.2.4 Superimposed running dimensioning is simplified parallel dimensioning and may be used where there are space limitations and where no legibility problems would occur (see Fig. 12.34 and 12.35).

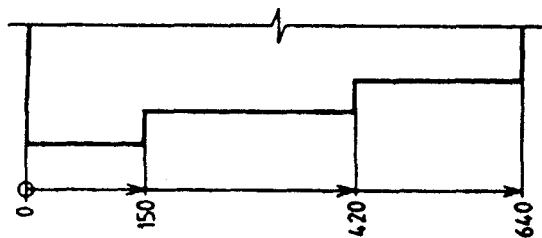


FIG. 12.34

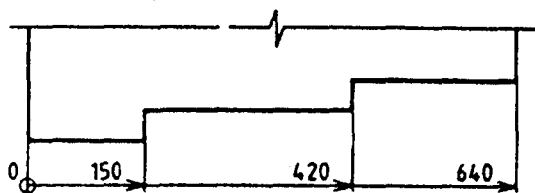


FIG. 12.35

The origin indication (see Fig. 12.12) is placed appropriately and the opposite ends of each dimension line shall be terminated only with an arrowhead.

Dimensional values may be placed, where there is no risk of confusion, either:

- near the arrowhead, in line with the corresponding projection line (see Fig. 12.34),
- or

- near the arrowhead, above and clear of the dimension line (see Fig. 12.35).

12.4.2.5 It may be advantageous to use superimposed running dimensioning in two directions. In such a case, the origins may be as shown in Fig. 12.36.

12.4.3 Dimensioning by Coordinates

12.4.3.1 It may be useful, instead of dimensioning as shown in Fig. 12.36, to tabulate dimensional values as shown in Fig. 12.37.

12.4.3.2 Coordinates for intersections in grids on block plans (site plans) are indicated as shown in Fig. 12.38.

Coordinates for arbitrary points of reference without a grid shall appear adjacent to each point (see Fig. 12.39) or in tabular form (see Fig. 12.40).

12.4.4 Combined Dimensioning

Single dimensions, chain dimensioning and dimensioning from a common feature may be combined on a drawing, if necessary (see Fig. 12.41 and 12.42).

12.5 Special Indications

12.5.1 Chords, Arcs, Angles and Radii

12.5.1.1 The dimensioning of chords, arcs and angles shall be as shown in Fig. 12.43.

12.5.1.2 Where the centre of an arc falls outside the limits of the space available, the dimension line of the radius shall be broken or interrupted according to

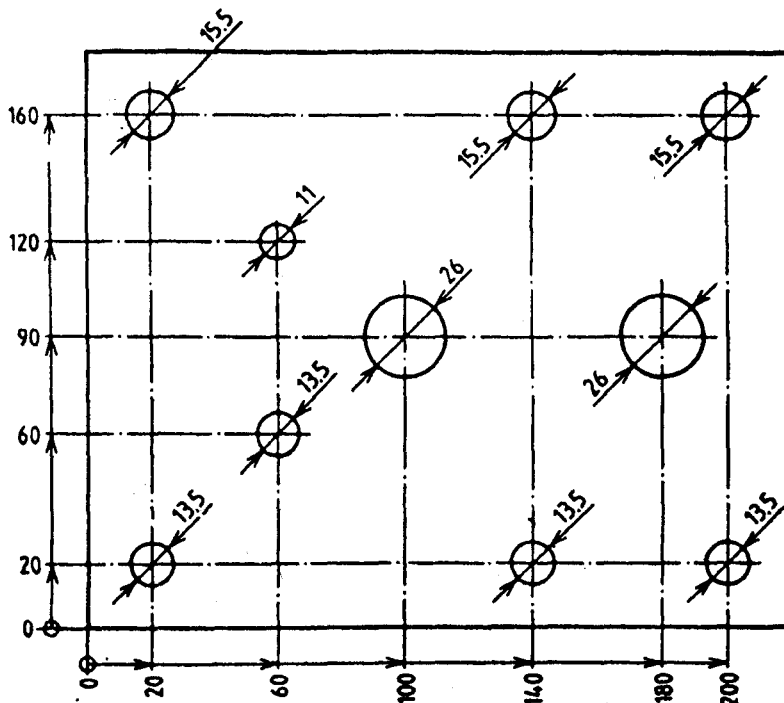


FIG. 12.36

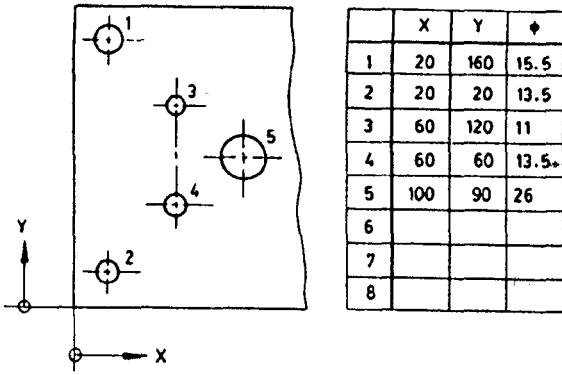


FIG. 12.37

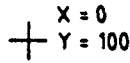


FIG. 12.38

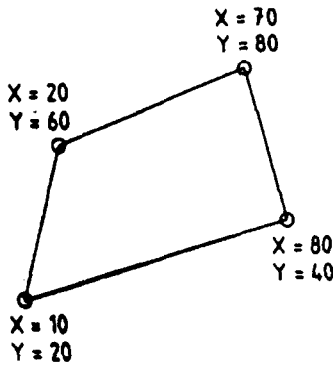


FIG. 12.39

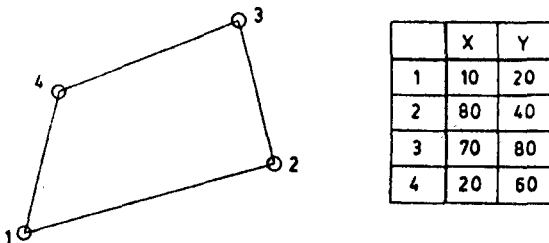


FIG. 12.40

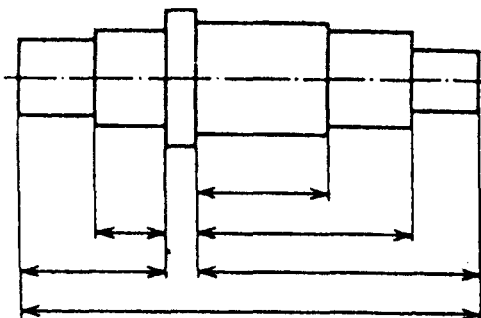


FIG. 12.41

whether or not it is necessary to locate the centre (see Fig. 12.15).

12.5.1.3 Where the size of the radius can be derived from other dimensions, it shall be indicated with a radius arrow and the symbol R without an indication of the value (see Fig. 12.44).

12.5.2 Equidistant Features

Where equidistant features or uniformly arranged elements are part of the drawing specification, dimensioning may be simplified as follows.

12.5.2.1 Linear spacings may be dimensioned as shown in Fig. 12.45. If there is any possibility of confusion between the length of the space and the number of spacings, one space shall be dimensioned as shown in Fig. 12.46.

12.5.2.2 Angular spacings of holes and other features may be dimensioned as shown in Fig. 12.47.

12.5.2.3 The angles of the spacings may be omitted if their number is evident without confusion (see Fig. 12.48).

12.5.2.4 Circular spacings may be dimensioned indirectly by giving the number of elements as shown in Fig. 12.49.

12.5.3 Repeated Features

If it is possible to define a quantity of elements of the same size so as to avoid repeating the same dimensional value, they may be given as shown in Fig. 12.50 and 12.51.

12.5.4 Chamfers and Countersinks

12.5.4.1 Chamfers shall be dimensioned as shown in Fig. 12.52. Where the chamfer angle is 45°, the indications may be simplified as shown in Fig. 12.53 and 12.54.

12.5.4.2 Countersinks are dimensioned by showing either the required diametral dimension at the surface and the included angle, or the depth and the included angle (see Fig. 12.55).

12.5.5 Other Indications

12.5.5.1 Where necessary, in order to avoid repeating the same dimensional value or to avoid long leader lines, reference letters may be used in connection with an explanatory table or note (see Fig. 12.56). Leader lines may be omitted.

12.5.5.2 In partially drawn views and partial sections of symmetrical parts, the dimension lines that need to cross the axis of symmetry are shown extended slightly beyond the axis of symmetry; the second termination is then omitted (see Fig. 12.57).

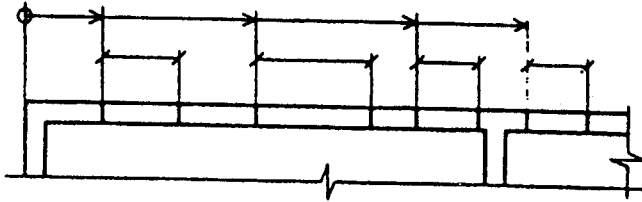


FIG. 12.42

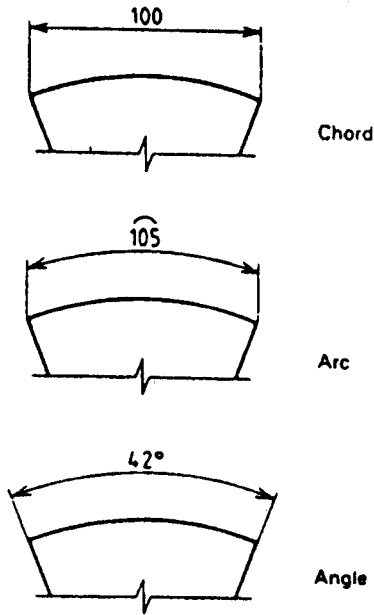


FIG. 12.43

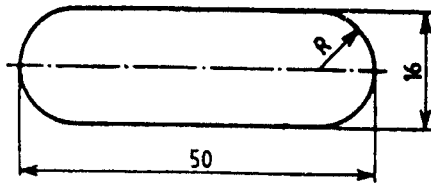


FIG. 12.44

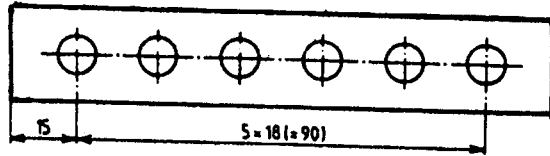


FIG. 12.45

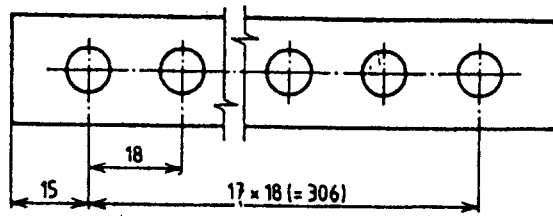


FIG. 12.46

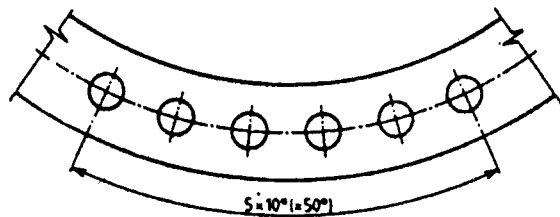


FIG. 12.47

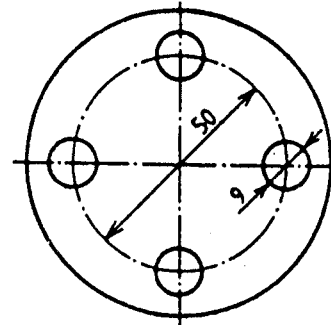


FIG. 12.48

12.5.5.3 Where several parts are drawn and dimensioned in an assembly, the groups of dimensions related to each part should be kept as separate as possible (see Fig. 12.58).

12.5.5.4 Sometimes it is necessary to dimension a limited area or length of a surface to indicate a special condition. In such instances, the area or length and its location are indicated by a long wide chain line, drawn adjacent and parallel to the surface and at a short distance from it.

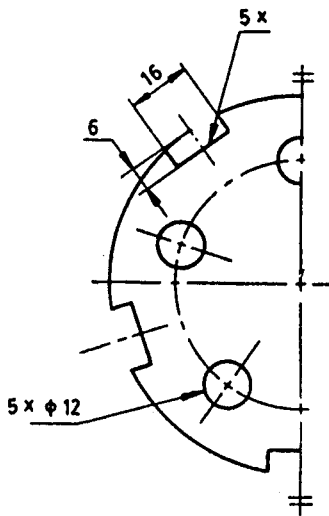


FIG. 12.49

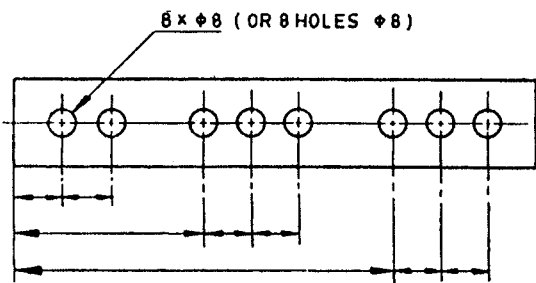


FIG. 12.50

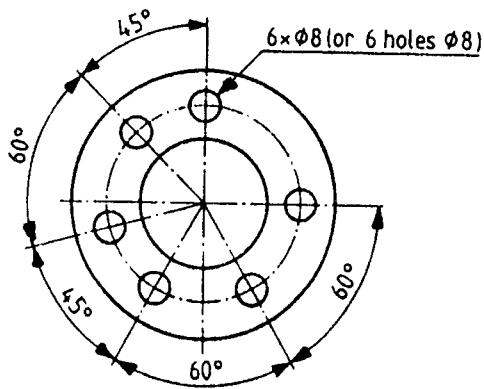


FIG. 12.51

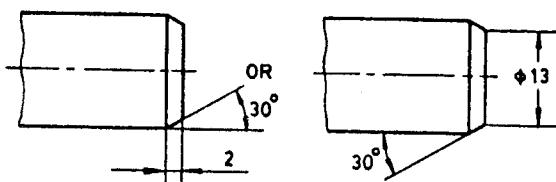


FIG. 12.52 CHAMFERS DIMENSIONED

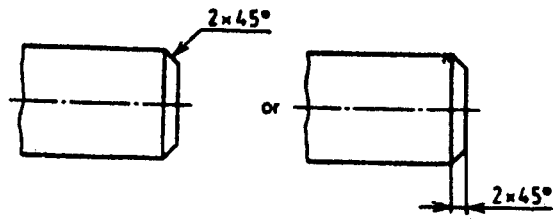


FIG. 12.53 45° CHAMFERS SIMPLIFIED

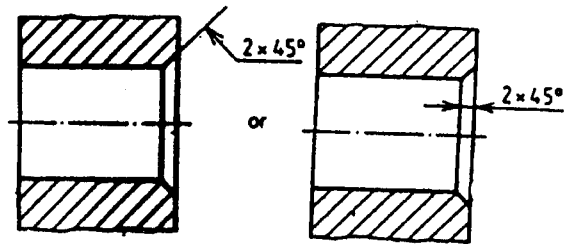


FIG. 12.54 INTERNAL CHAMFERS

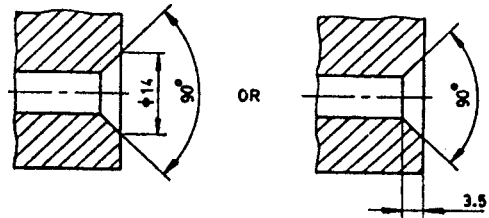
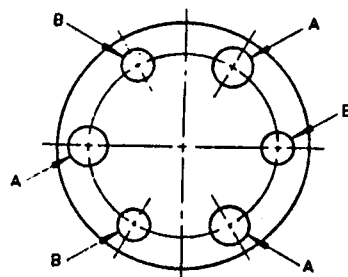


FIG. 12.55 COUNTERSINKS



A = 3 x φ12
B = 3 x φ10

FIG. 12.56

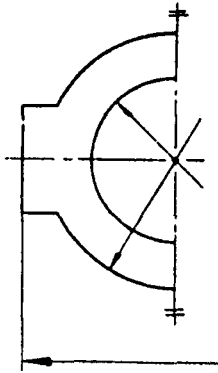


FIG. 12.57

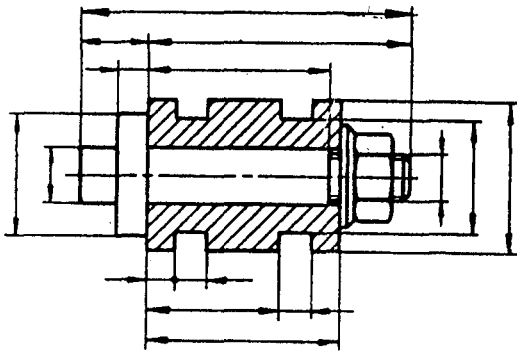


FIG. 12.58 DIMENSIONING AN ASSEMBLY

12.5.5.5 If special requirement is applied to an element of revolution, the indication shall be shown on one side only (see Fig. 12.59).

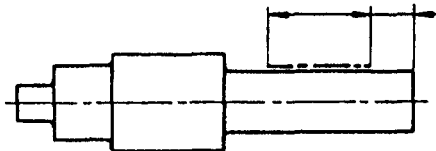


FIG. 12.59

12.5.5.6 Where the location and extent of the special requirement requires identification, the appropriate dimensioning is necessary. However, where the drawing clearly shows the extent of the indication, dimensioning is not necessary (see Fig. 12.60).

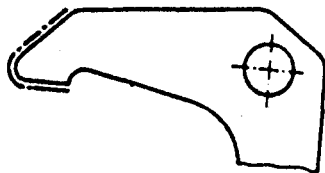


FIG. 12.60

12.6 Indication of Levels

12.6.1 General

Levels shall be expressed in appropriate units from a predetermined base-zero level.

12.6.2 Levels on Vertical Views and Sections

12.6.2.1 The predetermined base-zero level on vertical views and sections shall be indicated with a closed arrowhead with barbs at an included angle of 90°. The arrowhead shall point to a horizontal line, shall be half filled in, and shall be connected to a horizontal leader line by means of a short narrow line (see Fig. 12.61).

12.6.2.2 If it is required to indicate the altitude of the base-zero level, the base-zero level symbol is modified to include 0.000 directly above and the actual altitude directly below the horizontal leader line (see Fig. 12.62).



FIG. 12.61

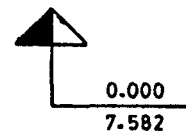


FIG. 12.62

12.6.2.3 Subsequent levels are indicated in vertical views and sections with an arrowhead with barbs at an included angle of 90° pointing to the respective level and attached to a short thin vertical line. The vertical line is connected at right angles to a horizontal leader line above which is placed the appropriate level dimension (see Fig. 12.63).

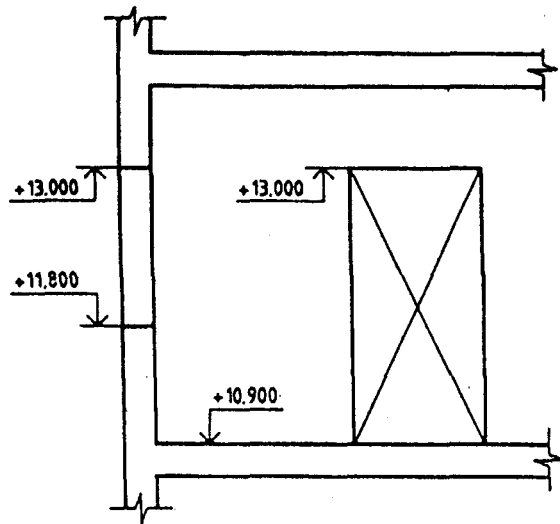


FIG. 12.63

12.6.3 Levels on Horizontal (Plan) Views and Sections

12.6.3.1 The numerical value of the level for a point (a specific location) shall be placed above the leader line that is connected to an X. The X is used to indicate the exact position of a particular point (see Fig. 12.64).

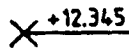


FIG. 12.64

12.6.3.2 If the specific location point is defined by two intersecting outlines, the X shall be replaced with a circle and the numerical value of the elevation shall be located above the leader line that is extended from the circle on the same side of the outline as the surface associated with the elevation (see Fig. 12.65).

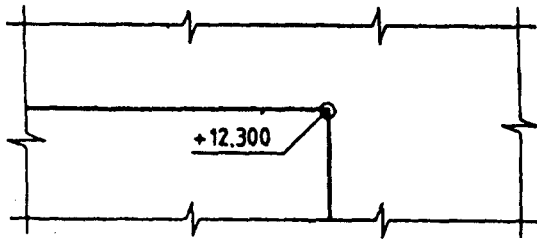
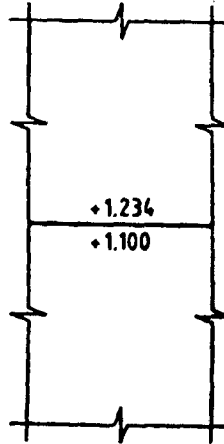


FIG. 12.65

12.6.3.3 The numerical value of an elevation of an outline shall be located adjacent to it and on the same side of it as the surface associated with the elevation (see Fig. 12.66).

Example



Meaning

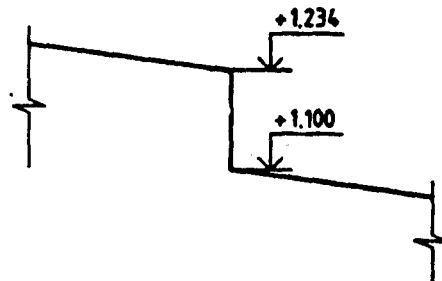


FIG. 12.66

12.6.4 Levels on Site Layout

12.6.4.1 Levels on ground preparation drawings and site plans shall be given as follows:

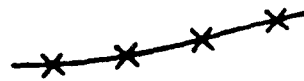
Original ground level to be used	+ 0.000
New ground level	+ 0.000
Original ground level no longer valid	(+ 0.000)

12.6.4.2 Levels for contour lines shall be located on the upper side of the contour line and shall be given as follows:

Contour line



Original contour line no longer valid



12.6.4.3 Elevation datum to be used when setting out dimensions shall be shown as follows:

⊕ FIX +0.000

SECTION 13 INDICATION OF LINEAR AND ANGULAR TOLERANCES ON TECHNICAL DRAWING

[Based on IS 11667 : 1991/ISO 406 : 1987]

13.1 Scope

This section specifies the indication of tolerances for linear and angular dimensions on technical drawings. Indicating such tolerances does not necessarily imply the use of any particular method of production, measurement or gauging.

13.2 Units

13.2.1 Units of the deviations shall be expressed in the same unit as the basic size.

13.2.2 If two deviations relating to the same dimension have to be shown, both shall be expressed to the same number of decimal places (see Fig. 13.2), except if one of the deviations is zero (see Fig. 13.5).

13.3 Indication of the Components of a Linear Dimension

13.3.1 ISO Symbols

The components of the toleranced dimension shall be indicated in the following order:

- a) the basic size, and
- b) the tolerance symbol.

13.3.1.1 If, in addition to the symbols (see Fig. 13.1), it is necessary to express the values of the deviations (see Fig. 13.2) or the limits of size (see Fig. 13.3), the additional information shall be shown in brackets.

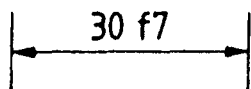


FIG. 13.1

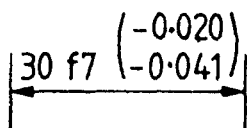


FIG. 13.2

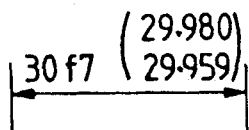


FIG. 13.3

13.3.2 Permissible Deviations

The components of the toleranced dimension shall be indicated in the following order (see Fig. 13.4 to 13.6):

- a) The basic size, and
- b) The value of the deviations.

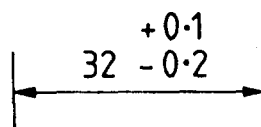


FIG. 13.4

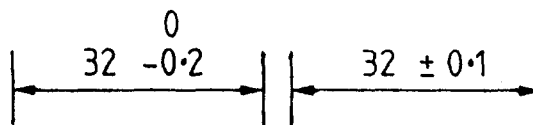


FIG. 13.5

FIG. 13.6

13.3.2.1 If one of the two deviations is zero, this should be expressed by the digit zero (see Fig. 13.5).

13.3.2.2 If the tolerance is symmetrical in relation to the basic size, the value of the deviations should be indicated once only, preceded by the sign \pm (see Fig. 13.6).

13.3.3 Limits of Size

The limits of size may be indicated by an upper and lower dimension (see Fig. 13.7).

13.3.4 Limits of Size in One Direction

If a dimension needs to be limited in one direction only, this should be indicated by adding 'min' or 'max' to the dimension (see Fig. 13.8).

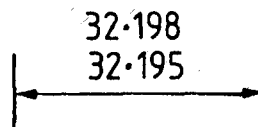


FIG. 13.7

13.4 Order of Indication of Deviations and Limits of Size

The upper deviation or the upper limit of size shall be written in the upper position and the lower deviation

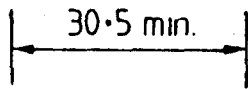


FIG. 13.8

or the lower limit of size in the lower position, irrespective of whether a hole or a shaft is toleranced.

13.5 Indication of Tolerances on Drawings of Assembled Parts

13.5.1 ISO Symbols

13.5.1.1 The tolerance symbol for the hole shall be placed before that for the shaft (see Fig. 13.9) or above it (see Fig. 13.10), the symbols being preceded by the basic size indicated once only.

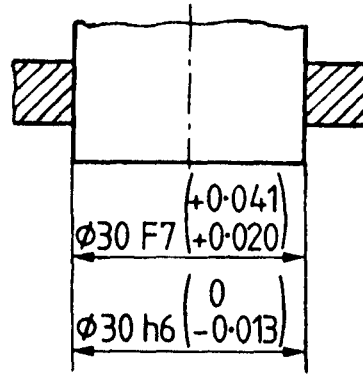


FIG. 13.11

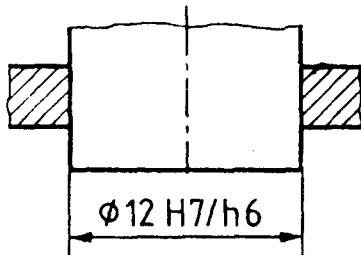


FIG. 13.9

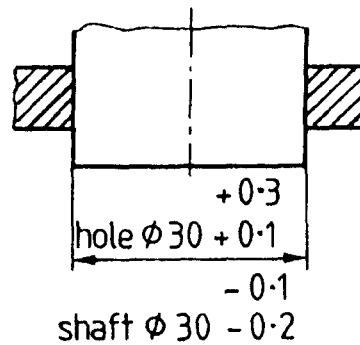


FIG. 13.12

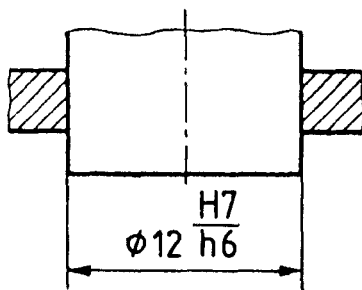


FIG. 13.10

13.5.1.2 If it is also necessary to specify the numerical values of the deviations, they should be written in brackets (see Fig. 13.11).

For the sake of simplicity, dimensioning with only one dimension line may be used (see Fig. 13.12).

13.5.2 Values by Digits

The dimension for each of the components of the assembled parts shall be preceded by the name (see Fig. 13.12) or item reference (see Fig. 13.13) of the components, the dimension for the hole being placed in both cases above that for the shaft.

13.6 Indication of Tolerances on Angular Dimensions

The rules given for the indication of tolerances on

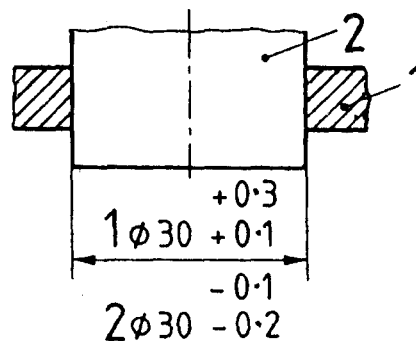


FIG. 13.13

linear dimensions are equally applicable to angular dimensions (see Fig. 13.16 and 13.17), except that the units of the basic angle and the fractions thereof, as well as the deviations, shall always be indicated (see Fig. 13.14 to 13.17). If the angular deviation is expressed in either minutes of a degree or seconds of a minute of a degree, the value of the minute or second shall be preceded by 0° or $0'0''$ as applicable.

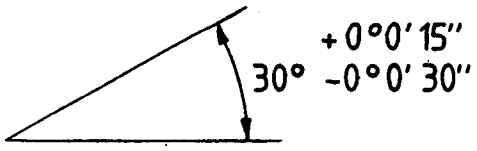


FIG. 13.14

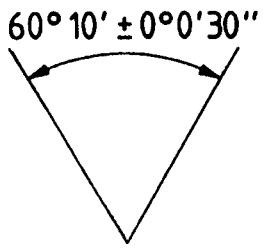


FIG. 13.15



FIG. 13.16

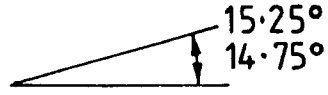


FIG. 13.17

SECTION 14 DIMENSIONING OF CONES

[Based on IS 10718 : 1993/ISO 3040 : 1990]

14.1 Scope

This section establishes the definition of cones and specifies the graphical symbol to be used for their indication and methods for their dimensioning.

For the purposes of this section, the term 'cone' relates to right-angle circular cones only.

NOTES

- 1 For simplicity, only truncated cones have been represented in this section. However this section can be applied to any type of cone within its scope.
- 2 This section is not intended to prevent the use of other methods of dimensioning.

14.2 Definition

For the purposes of this section, the following definition applies.

Rate of taper C: Ratio of the difference in the diameters of two sections of a cone to the distance between them. It is expressed by the following formula (see also Fig. 14.1):

$$C = \frac{D - d}{L} = 2 \tan\left(\frac{\alpha}{2}\right)$$

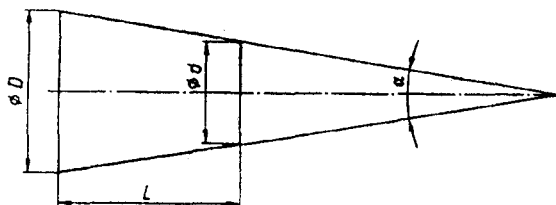


FIG. 14.1

14.3 Graphical Symbol for a Cone

A cone shall be indicated using the graphical symbol illustrated in Fig. 14.2 positioned on a reference line (see Fig. 14.7). The orientation of the graphical symbol shall coincide with that of the cone (see Fig. 14.7 and Fig. 14.8).

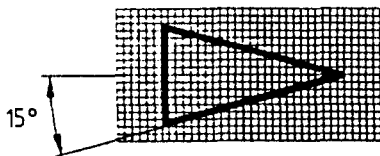


FIG. 14.2

For the size and line thickness of the graphical symbol, see ISO 3461-2.

14.4 Dimensioning of Cones

14.4.1 Characteristics of Cones

In order to define a cone, the characteristics and dimensions shown in Table 14.1 may be used in those combinations most appropriate for the function of the cone.

No more dimensions than are necessary shall be specified. However, additional dimensions (for example, half the included angle) may be given as 'auxiliary' or 'reference' dimensions in brackets for information.

Typical combinations of cone characteristics and dimensions are shown in Fig. 14.3 to Fig. 14.6.

Table 14.1 Characteristics and Dimensions of Cones
(Clause 14.4.1)

Characteristics and Dimensions	Letter Symbol	Examples of Indication	
		Preferred Method	Optional Method
<i>Characteristics</i>			
Rate of taper	C	1 : 5 1/5	0.2 : 1 20 %
Cone angle	α	35°	0.6 rad
<i>Cone diameter</i>			
- at the larger end	D		
- at the smaller end	d		
- at the selected cross-section	D _x		
<i>Length</i>			
Cone length	L		
Length including cone length	L'		
Length locating a cross-section at which D _x is specified	L _x		

14.4.2 Indication of Rate of Taper on Drawings

The graphical symbol and the rate of taper of a cone shall be indicated near to the feature, and the reference line shall be connected to the outline of the cone by a leader line as shown in Fig. 14.7. The reference line shall be drawn parallel to the centre-line of the cone, and the orientation of the graphical symbol shall coincide with that of the cone.

14.4.3 Standardized Series of Cones

When the taper to be indicated is one of a standardized series of conical taper (in particular Morse or metric taper), the tapered feature may be designated by specifying the standard series (see ISO 1119) and appropriate number (see Fig. 14.8).

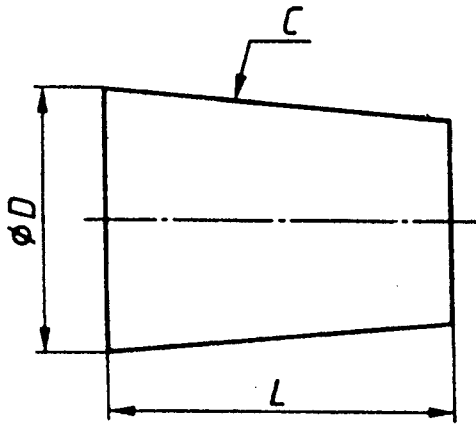


FIG. 14.3

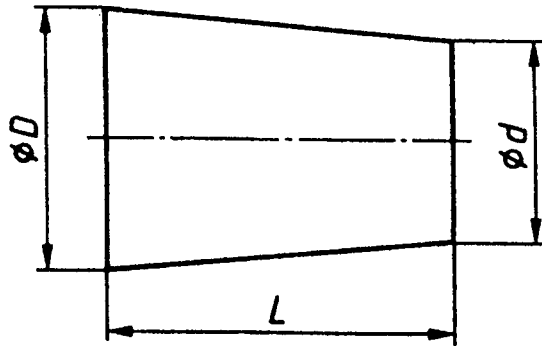


FIG. 14.6

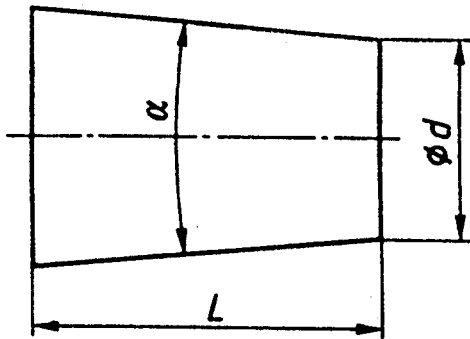


FIG. 14.4

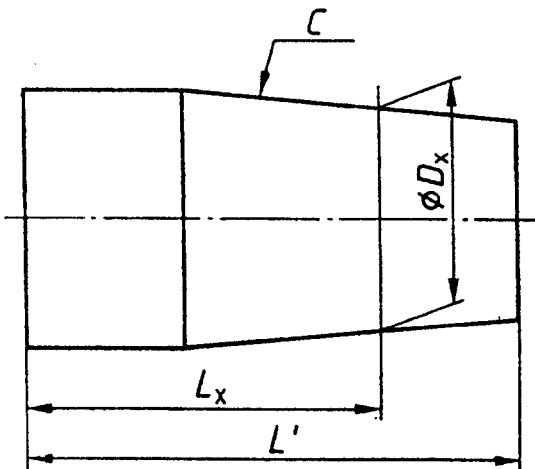


FIG. 14.5

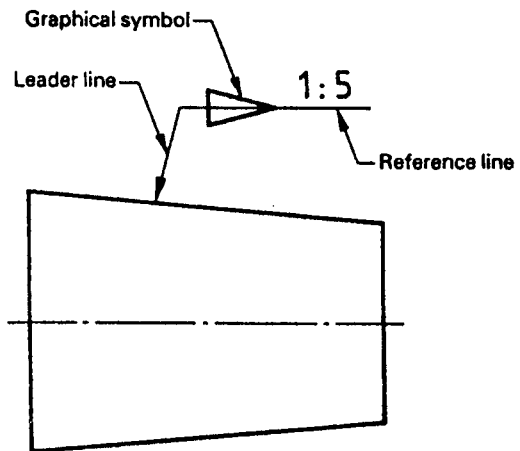


FIG. 14.7

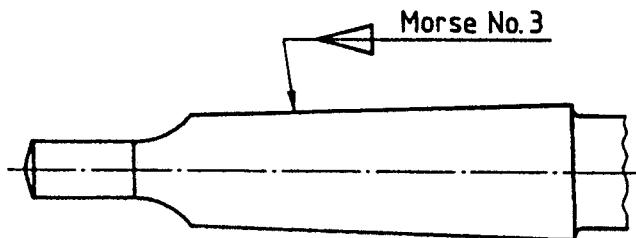


FIG. 14.8

SECTION 15 INDICATION OF SURFACE TEXTURE IN TECHNICAL PRODUCT DOCUMENTATION

[Based on ISO/DIS 1302 : 1999]

15.1 Scope

This section specifies the rules for the indication of surface texture in technical product documentation, (for example, drawings, specifications, contracts, reports) by means of graphical symbols and textual indications.

15.2 Definitions

15.2.1 Basic Graphical Symbol (for Surface Texture)

Graphical symbol indicating that a requirement for surface texture exists.

NOTE — See Fig. 15.1

15.2.2 Expanded Graphical Symbol (for Surface Texture)

Expanded basic graphical symbol indicating that material is to be either removed or not removed in order to obtain the specific surface texture.

NOTE — See Fig. 15.2 and 15.3.

15.2.3 Complete Graphical Symbol (for Surface Texture)

Basic or expanded graphical symbol expanded in order to facilitate the addition of complementary surface texture requirements.

NOTE — See Fig. 15.4.

15.2.4 Surface (Texture) Parameter

Parameter expressing a micro geometrical property of a surface.

15.2.5 (Surface) Parameter Symbol

Symbol indicating the type of surface texture parameter.

NOTE — The parameter symbols are consisting of letters and numerical values for example : R_a , $R_{a\max}$, W_z , $W_{zI\max}$, AR , R_{pk} , R_{pq} , etc.

15.3 Graphical Symbols for the Indication of Surface Texture

Requirements for surface texture are indicated on technical drawings by several variants of graphical symbols each having their own significant meaning. These graphical symbols shall usually be supplemented with complementary surface texture

requirements in the form of numerical values and text (see 15.4), but it shall be recognized that the graphical symbols used alone in some instances can have a special meaning on the technical drawing (see 15.5).

15.3.1 Basic Graphical Symbols for Surface Texture

The basic graphical symbols consist of two straight lines of unequal length inclined at approximately 60° to the line representing the considered surface, as shown in Fig. 15.1. The basic graphical symbol in Fig. 15.1 used alone (without complementary information) is not a requirement.



FIG. 15.1 BASIC GRAPHICAL SYMBOL FOR SURFACE TEXTURE

If the basic graphical symbol is used with complementary supplementing information (see 15.4), then no decision is taken as to whether removal of material is necessary for obtaining the specified surface (see 15.3.2), or whether it is not allowed to remove material for obtaining the specified surface (see 15.3.3).

15.3.2 Basic Graphical Symbol for Removal of Material

If removal of material by machining is required for obtaining the specified surface, a bar shall be added to the basic graphical symbol, as shown in Fig. 15.2. The expanded graphical symbol on Fig. 15.2 used alone (without complementary information) is not a requirement.



FIG. 15.2 EXPANDED GRAPHICAL SYMBOL INDICATING THAT REMOVAL OF MATERIAL IS REQUIRED

15.3.3 Expanded Graphical Symbol when Removal of Material is not Permitted

If removal of material is not permitted for obtaining the specified surface, a circle shall be added to the basic graphical symbol, as shown in Fig. 15.3.



FIG. 15.3 EXPANDED GRAPHICAL SYMBOL WHEN REMOVAL OF MATERIAL IS NOT PERMITTED

15.3.4 Complete Graphical Symbol

When complementary requirements for surface texture characteristics have to be indicated (see 15.4), a line is added to the longer arm of any of the graphical symbols illustrated in Fig. 15.1 to 15.3, as shown in Fig. 15.4.

15.3.5 Graphical Symbol for 'All Surfaces Around a Workpiece Outline'

When the same surface texture is required on all surfaces around a workpiece (integral features), represented on the drawing by a closed outline of the workpiece, a circle is added to the complete graphical symbol illustrated in Fig. 15.4, as shown in Fig. 15.5.

15.4 Indication of Surface Texture Requirements

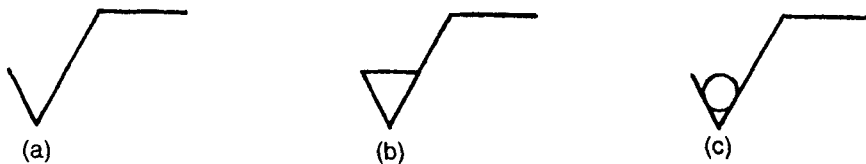
In order to ensure unambiguity of a surface texture requirement in relation to the function of the particular surface, it is necessary, in addition to the indication of both a surface texture parameter and the requirement(s) for its numerical value, to give other requirement, for example, transmission band or sampling length, manufacturing process, surface lay and its orientation and a possible machining allowances. It may be necessary to set up requirements for several different surface texture parameters in order that the surface requirements ensure unambiguous functional properties of the surface.

15.4.1 Position of Complementary Surface Texture Requirements in the Complete Graphical Symbol

The positions of the various surface texture requirements in the complete graphical symbol are shown in Fig. 15.6.

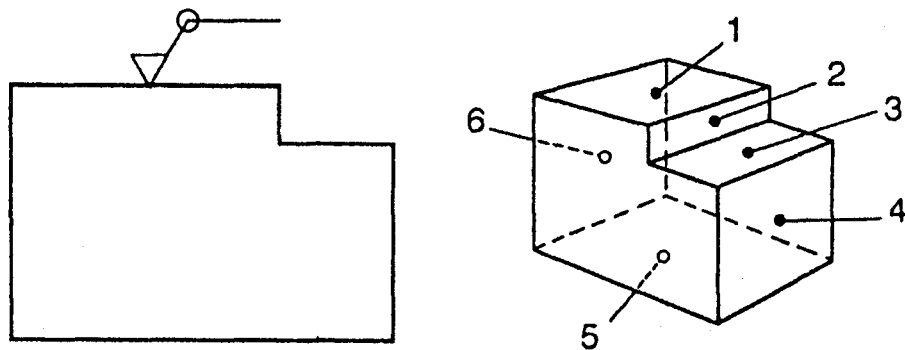
15.4.1.1 Surface texture parameter, numerical value and transmission band/sampling length

Surface texture parameters, numerical values and transmission band/sampling length are to be located at specific positions in the complete graphical symbol in the following manner.



(a) any manufacturing process permitted (b) material shall be removed (c) material shall not be removed

FIG. 15.4 COMPLETE GRAPHICAL SYMBOL



NOTE — The outline on the drawing represent the six surfaces shown on the 3D-representation of the workpiece.

FIG. 15.5 EXAMPLE OF A SURFACE TEXTURE REQUIREMENT APPLYING TO ALL (SIX) SURFACES REPRESENTED BY THE OUTLINE ON THE DRAWING

a) *One single surface texture requirement (position a)*

If only one single surface texture requirement, consisting of the surface texture parameter, the numerical value and the transmission band/sampling length, is to be indicated in the complete graphical symbol, it shall be located in the complete graphical symbol in position 'a' (Fig. 15.7).

b) *Two or more surface texture requirements (position a and b)*

If one complete graphical symbol is used to indicate two or more surface texture requirements, it shall be indicated as follows:

The first surface texture requirement is located at position *a* [as stated in 15.4.1.1 (a)]. The second surface texture requirement shall be located at position *b*. If a third or more requirements are to be indicated, the graphical symbol is enlarged accordingly in the vertical direction, to make room for more lines. The position *a* and *b* is moving upwards, when the symbol is enlarged.

15.4.1.2 *Manufacturing method (position c)*

The manufacturing method, treatment, coatings or other requirements for the manufacturing process etc, to produce the surface, for example, turned, ground, plated, etc shall be located at position 'c' (see Fig. 15.7) (see also 15.4.2).

15.4.1.3 *Surface lay and orientation (position d)*

The symbol of the required surface lay and the orientation, if any, of the surface lay, for example, '=', 'X', 'M', etc, are located at position 'd' (see Fig. 15.7), (see also 15.4.3).

15.4.1.4 *Machining allowance (position e)*

The required machining allowance is indicated as a numerical value given in millimetre at position 'e' (see Fig. 15.7) (see also 15.4.4).

15.4.2 *Indication of Manufacturing Method or Other Information Regarding the Method*

The surface texture parameter value of an actual surface is strongly influenced by the detailed form of the profile curve. A parameter designation, parameter value and transmission band — indicated solely as a surface texture requirement — do therefore not

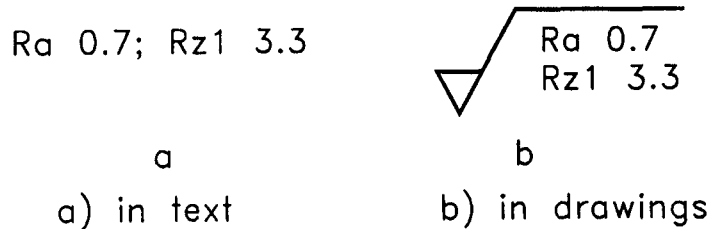


FIG. 15.6 PARAMETER DESIGNATION

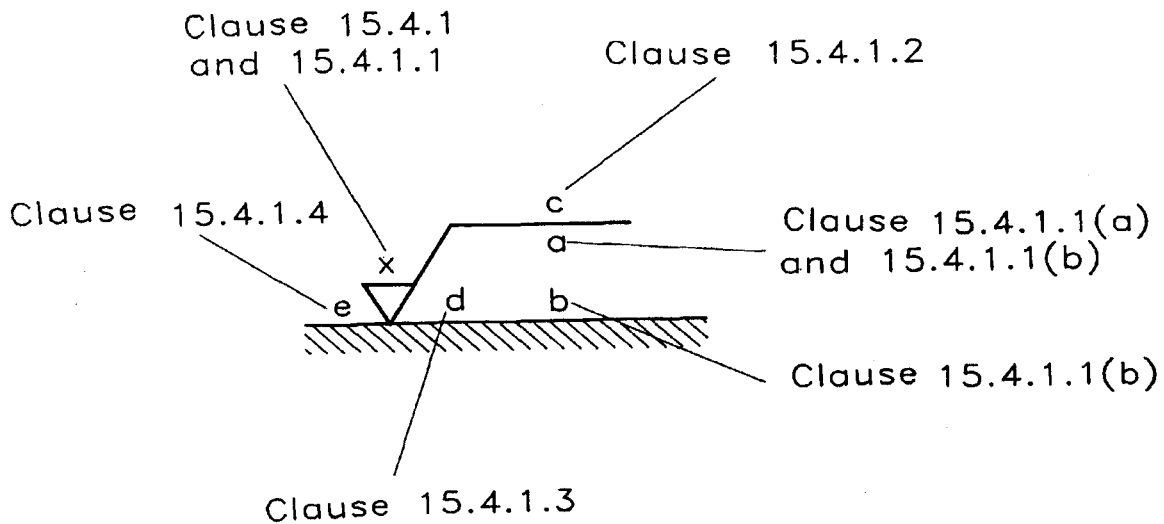


FIG. 15.7 POSITIONS (a - e) FOR THE LOCATION OF COMPLEMENTARY REQUIREMENTS

necessarily result in unambiguous function of the surface. It is consequently necessary in almost all cases to state the manufacturing process, as this process to some extent results in a particular detailed form of the profile curve.

There may also be other reasons for finding it appropriate to indicate the process.

The manufacturing process of the specified surface can be presented as a text and be added to the complete symbol as shown in Fig. 15.8 and 15.9. The coating in Fig. 15.11 is an example indicated using the symbolic presentation. The addition to the complete symbol can be used only as information — also in addition to the information of importance to the geometrical properties of the surface, for example, coating thickness, coating types, etc.

15.4.3 Indication of the Surface Lay

The surface lay and direction of the lay emanating from the machining process (for example, traces left

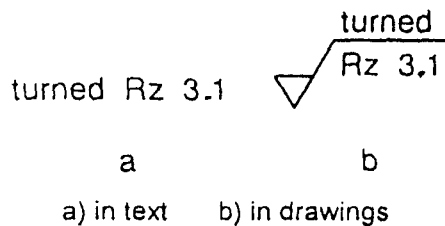


FIG. 15.8 INDICATION OF A MACHINING PROCESS AND THE REQUIREMENT FOR THE ROUGHNESS OF THE RESULTING SURFACE

by tools) can be indicated in the complete symbol by using the symbols shown in Table 15.1 and illustrated by the example in Fig. 15.10. The indication of surface lay by the defined symbols is not applicable to textual indications.

The symbols in Table 15.1 indicate the lay and direction of lay in relation to the drawing plane containing the surface texture requirement.

15.4.4 Indication of Machining Allowance

The machining allowance is generally indicated only in those cases where more process stages are shown in

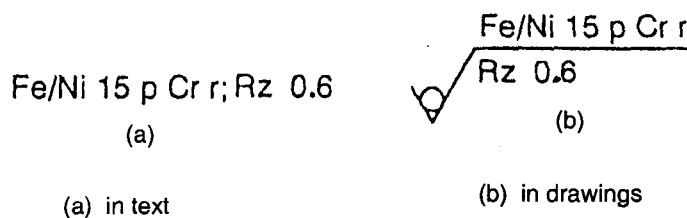
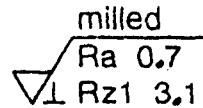


FIG. 15.9 INDICATION OF A COATING AND THE ROUGHNESS REQUIREMENT



NOTE — The direction of lay is the direction of the prevailing surface pattern which is usually determined by the manufacturing process used.

FIG. 15.10 DIRECTION OF LAY OF THE SURFACE PATTERN INDICATED AS BEING PERPENDICULAR TO THE DRAWING PLANE

the same drawing. Machining allowances are therefore found, for example, in drawings of raw cast and forged workpieces with the final workpiece being shown in the raw workpiece. The indication of machining allowance by the defined symbol is not applicable to textual indications.

When the machining allowance is indicated, it may occur that the requirement for the machining allowance is the only requirement added to the complete symbol. The machining allowance may also be indicated in connection with a normal surface texture requirement (see Fig. 15.11).

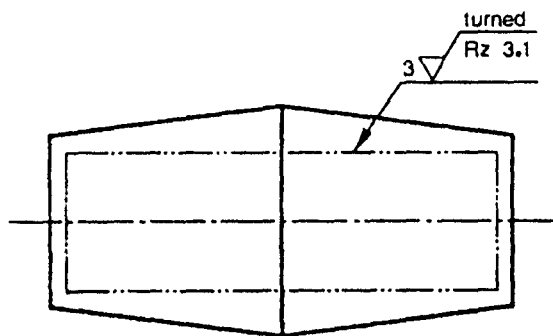
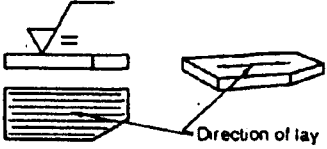
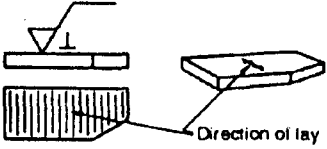
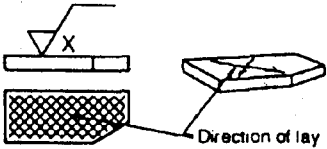
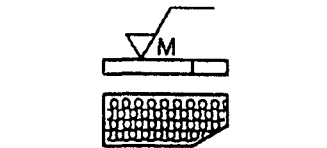
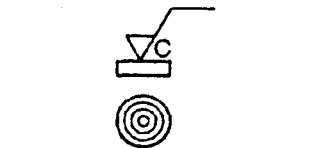
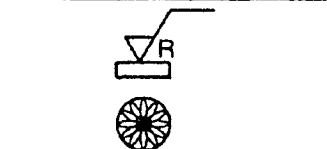
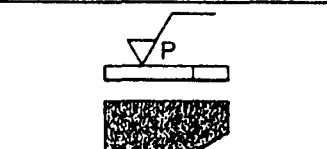


FIG. 15.11 INDICATION OF SURFACE TEXTURE REQUIREMENTS FOR THE 'FINAL' WORKPIECE SHOWN ON THE CASTING DRAWING, INCLUDING A REQUIREMENT FOR A MACHINING ALLOWANCE OF 3 mm

Table 15.1 Indication of Surface Lay
(Clause 15.4.3)

Graphical symbol	Interpretation and example	
=	Parallel to the plane of projection of the view in which the symbol is used	
⊥	Perpendicular to the plane of projection of the view in which the symbol is used	
X	Crossed in two oblique directions relative to the plane of projection of the view in which the symbol is used	
M	Multi-directional	
C	Approximately circular relative to the centre of the surface to which the symbol applies	
R	Approximately radial relative to the centre of the surface to which the symbol applies	
P	Lay is particulate, non-directional, or protuberant	
<p>NOTE – If it is necessary to specify a surface pattern which is not clearly defined by these symbols, this shall be achieved by the addition of a suitable note to the drawing.</p>		

15.5 Indication on Drawings and Other Technical Product Documentation

Surface texture requirements shall be indicated only once for a given surface and, if possible, on the same view where the size and/or location are indicated and tolerated.

Unless otherwise specified, the indicated surface texture requirements are applicable for the surface after machining, coating, etc.

15.5.1 Position and Orientation of the Graphical Symbol and its Annotation

The general rule is that the graphical symbol together with the complementary information shall be oriented so that they can be read from the bottom or right-hand side of the drawing (see Fig. 15.12).

15.5.1.1 On an outline or by a leader line

The surface texture requirement (graphical symbol) shall touch the surface or be connected to it by means of a leader line terminating in an arrowhead.

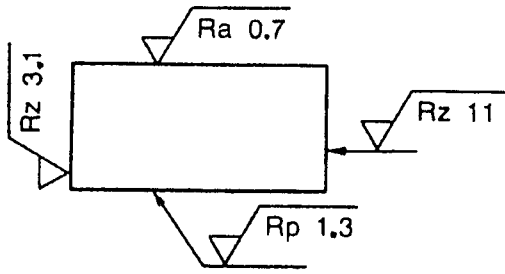


FIG. 15.12 DIRECTION OF READING OF SURFACE TEXTURE REQUIREMENTS

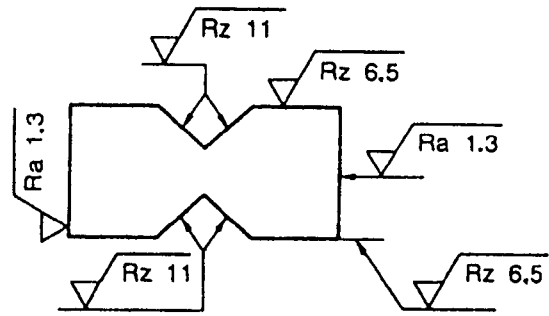


FIG. 15.13 SURFACE TEXTURE REQUIREMENTS ON THE CONTOUR LINE THAT REPRESENTS THE SURFACE

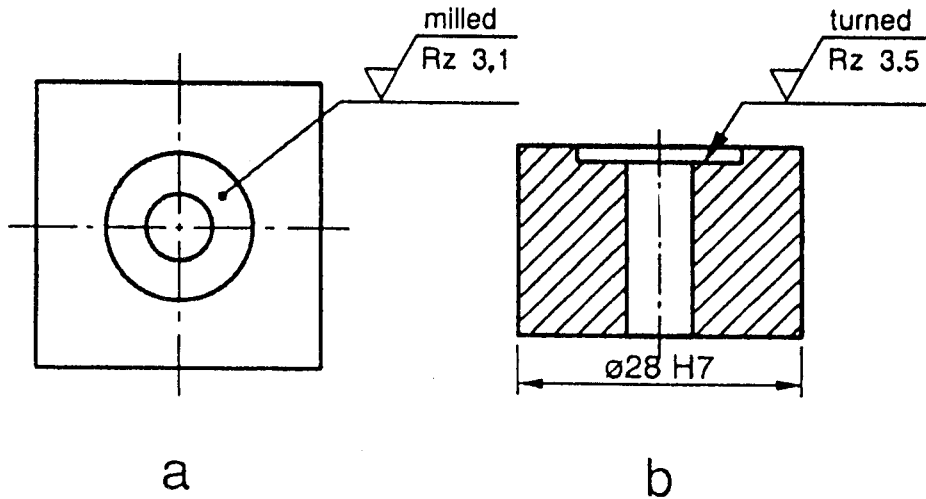


FIG. 15.14 ALTERNATIVE USE OF LEADER LINES

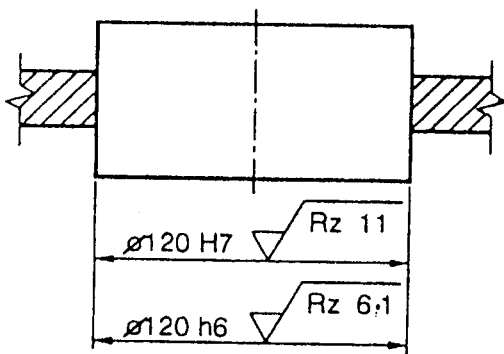


FIG. 15.15 SURFACE TEXTURE REQUIREMENT IN CONNECTION WITH THE DIMENSION OF A FEATURE OF SIZE

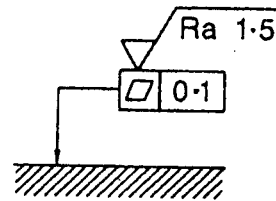


FIG. 15.16 SURFACE TEXTURE REQUIREMENT CONNECTED TO INDICATION OF GEOMETRICAL TOLERANCES

15.5.1.2 *On the dimension line in connection with the dimension of a size feature*

If there is no risk of mis-interpretation, the surface texture requirement may be indicated in connection with the dimensions given, as shown in Fig. 15.15.

15.5.1.3 *On the tolerance frame for geometrical tolerances*

The surface texture requirement may be placed on top of the tolerance frame for geometrical tolerances, as shown in Fig. 15.16.

As a general rule the graphical symbol shall, or the leader line terminating in an arrowhead, shall point at the surface from outside the material of the workpiece either to the outline (representing the surface) or the extension of it (see Fig. 15.13 and 15.14).

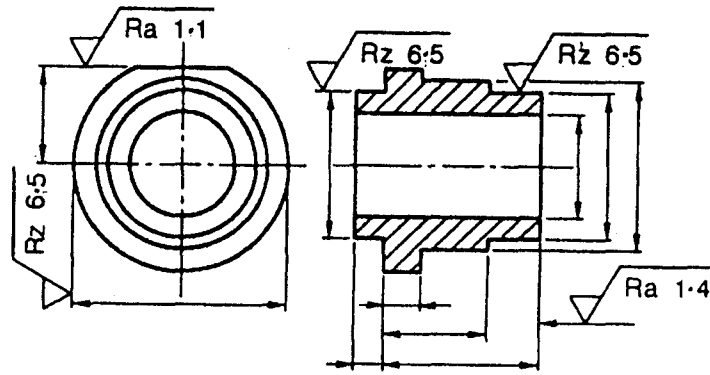


FIG. 15.17 SURFACE TEXTURE REQUIREMENTS ON EXTENSION LINES OF CYLINDRICAL FEATURES

15.5.1.4 On extension lines

The surface texture requirement may be directly placed on extension lines or be connected to it by a leader line terminating in an arrowhead, as shown in Fig. 15.13 and 15.17.

15.5.1.5 Cylindrical and prismatic surfaces

Cylindrical as well as prismatic surfaces need only be specified once if indicated by a centreline and if each prismatic surface have the same surface texture requirement (see Fig. 15.17).

However, each prismatic surface needs to be indicated separately if different surface textures are required on the individual prismatic surfaces (see Fig. 15.18).

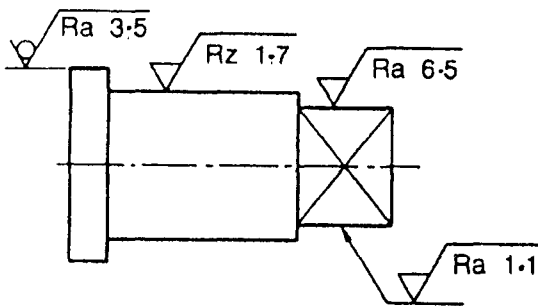


FIG. 15.18 SURFACE TEXTURE REQUIREMENTS FOR CYLINDRICAL AND PRISMATIC SURFACES

15.5.2 Simplified Drawing Indications of Surface Texture Requirements

15.5.2.1 Majority of surfaces having the same surface texture requirement

If the same surface texture is required on the majority of the surfaces of a workpiece, this surface texture requirement may be placed close to the title block of the drawing.

This general graphical symbol corresponding to this surface texture shall be followed by:

- a basic symbol in parenthesis without any other indication (see Fig. 15.19), or

— the special deviating surface texture requirement(s) in parenthesis (see Fig. 15.20).

in order to indicate that there exist other surface texture requirements that deviates from the general surface texture requirement.

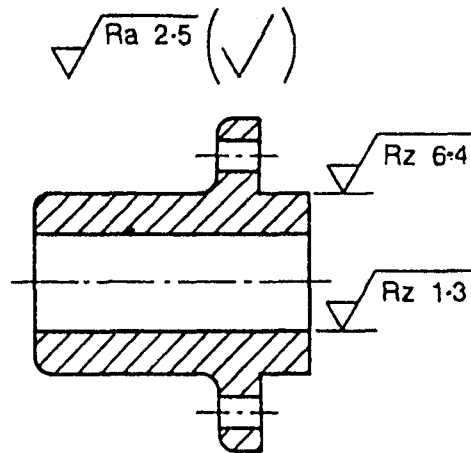


FIG. 15.19 SIMPLIFIED INDICATION WHEN A MAJORITY OF SURFACES HAVE THE SAME REQUIRED SURFACE TEXTURE

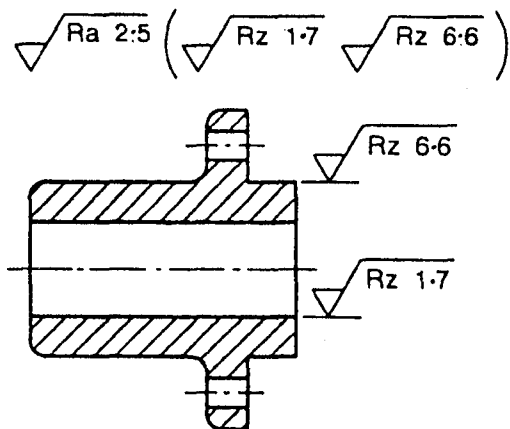


FIG. 15.20 SIMPLIFIED INDICATION WHEN A MAJORITY OF SURFACES HAVE THE SAME REQUIRED SURFACE TEXTURE

Surface texture requirements that deviates from the general surface texture requirement is indicated directly on the drawing in the same view of the particular surfaces in question (see Fig. 15.19 and 15.20).

15.5.2.2 Special use of reference indication

If the same surface texture is required on a large number of surfaces of the workpiece, the corresponding graphical symbol shown in Fig. 15.1, 15.2 or 15.3 may be used on the appropriate surface and its meaning given on the drawing as shown, for example, in Fig. 15.21 to 15.23.

$$\checkmark = \sqrt{\text{Ra } 3.1}$$

FIG. 15.21 SIMPLIFIED INDICATION OF SURFACE TEXTURE REQUIREMENTS WHEN MANUFACTURING PROCESS IS NOT SPECIFIED

$$\checkmark = \sqrt{\text{Ra } 3.1}$$

FIG. 15.22 SIMPLIFIED INDICATION OF SURFACE TEXTURE REQUIREMENT WHEN REMOVAL OF MATERIAL IS REQUIRED

$$\checkmark = \sqrt{\text{Ra } 3.1}$$

FIG. 15.23 SIMPLIFIED INDICATION OF SURFACE TEXTURE REQUIREMENT WHEN REMOVAL OF MATERIAL IS NOT PERMITTED

15.5.3 Indication of 2 Processes

If it is necessary to define surface texture both before and after treatment, this shall be explained in a note or in accordance with Fig. 15.24.

15.6 Synoptic Tables (see Table 15.2 to 15.5)

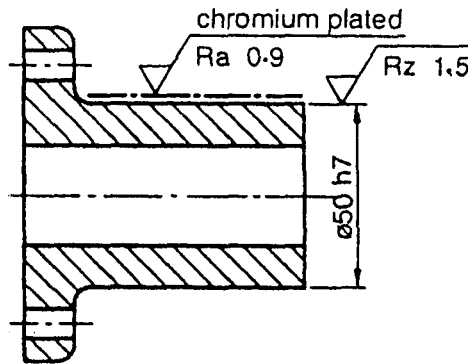


FIG. 15.24 INDICATION OF SURFACE TEXTURE REQUIREMENT BEFORE AND AFTER TREATMENT (IN THIS CASE COATING)

Table 15.2 Graphical Symbols with No Inscription
(Clause 15.6)

Reference no.	Symbol	Meaning
1		Fundamental graphical symbol. It may only be used in isolation when its meaning is "the surface under consideration" or explained by a note (see 15.5.2).
2		Basic graphical symbol. A machining surface with no indication of other details. Used in isolation this basic graphical symbol may be used only when its meaning is "a surface to be machined".
3		Basic graphical symbol. A surface from which removal of material is prohibited. This basic graphical symbol may also be used in a drawing relating to a manufacturing process to indicate that a surface is to be left in the state resulting from a preceding manufacturing process, regardless whether this state was achieved by removal of material or otherwise.

Table 15.3 Graphical Symbols with Indication of Surface Texture
(Clause 15.6)

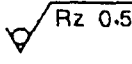
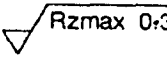
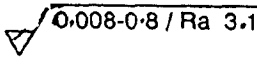
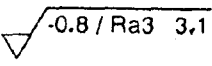
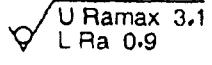
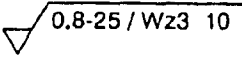
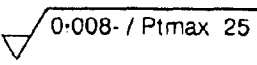
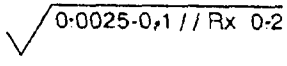
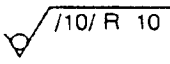
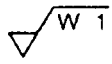
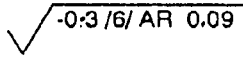
Reference no.	Symbol	Meaning/Explanation
1		The process is not permitted to remove material, unilateral upper specification limit, default transmission band, <i>R</i> -profile, maximum height of roughness 0,5 μm , evaluation length of 5 sampling lengths (default), "16%-rule" (default)
2		The process shall remove material, unilateral upper specification limit, default transmission band, <i>R</i> -profile, maximum height of roughness 0,3 μm , evaluation length of 5 sampling lengths (default), "max-rule"
3		The process shall remove material, unilateral upper specification limit, transmission band 0,008-0,8 mm, <i>R</i> -profile, arithmetic mean deviation 3,1 μm , evaluation length of 5 sampling lengths (default), "16%-rule" (default)
4		The process shall remove material, unilateral upper specification limit, transmission band: sampling length 0,8 mm (λ_s default 0,0025 μm) according to ISO 3274, <i>R</i> -profile, arithmetic mean deviation 3,1 μm , evaluation length of 3 sampling lengths (default), "16%-rule" (default)
5		The process is not permitted to remove material, double-sided upper and lower specification limits, default transmission band for both limits, <i>R</i> -profile, upper limit: arithmetic mean deviation 3,1 μm , evaluation length of 5 sampling lengths (default), "max-rule", lower limit: arithmetic mean deviation 0,8 μm , evaluation length of 5 sampling lengths (default), "16%-rule" (default)
6		The process shall remove material, unilateral upper specification limit, transmission band 0,8 - 25 mm, <i>W</i> -profile, maximum height of waviness 10 μm , evaluation length of 3 sampling lengths, "16%-rule" (default)
7		The process shall remove material, unilateral upper specification limit, transmission band $\lambda_s = 0,008$ mm no long wave filter, <i>P</i> -profile, total profile height 25 μm , evaluation length equal workpiece length (default), "max-rule"
8		Any manufacturing process, unilateral upper specification limit, transmission band $\lambda_s = 0,002$ mm - 5 mm; $\lambda = 0,1$ mm, evaluation length 3,2 mm (default), roughness motif parameter, maximum depth of roughness motif 0,2 μm , "16 %-rule" (default)

Table 15.3 — (Concluded)

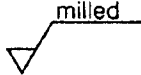


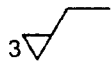
Reference no.	Symbol	Meaning/Explanation
9		The process is not permitted to remove material, unilateral upper specification limit, transmission band $l_s = 0,008$ mm (default), $A = 0,5$ mm (default), evaluation length 10 mm, roughness motif parameter, maximum mean depth of roughness motif 10 μm , "16 %-rule" (default)
10		The process shall remove material, unilateral upper specification limit, transmission band $A = 0,5$ mm (default); $B = 2,5$ mm (default), evaluation length 16 mm (default), waviness motif parameter, maximum mean depth of waviness motif 1 000 μm , "16 %-rule" (default)
11		Any manufacturing process, unilateral upper specification limit, transmission band $l_s = 0,008$ mm (default); $A = 0,3$ mm, evaluation length 6 mm, roughness motif parameter, maximum mean spacing of roughness motif 0,09 mm, "16 %-rule" (default)

NOTE Surface texture parameters, transmission bands/sampling lengths and parameter values and choice of symbols are given as examples only

Table 15.4 Symbols with Supplementary Information

(Clause 15.6)


(These indications may be used in combination with the appropriate graphical symbols from Table 15.3.)

Reference no.	Symbol	Meaning
1		Manufacturing method: milled (see 15.4.2)
2		Surface pattern: direction of lay perpendicular to the plane of projection of the view (see 15.4.3)
3		Surface texture requirement applies to complete closed outline of the projection view (see 15.3.5)
4		Machining allowance 3 mm (see 15.4.4)

NOTE The manufacturing method, surface pattern, and machining allowance are given as examples only.

Table 15.5 Simplified Symbols

(Clause 15.6)

Reference no.	Symbol	Meaning
1		The meaning is defined by text added to the drawing (see 15.5.2.1)

SECTION 16 SIMPLIFIED REPRESENTATION OF THE ASSEMBLY OF PARTS WITH FASTENERS — GENERAL PRINCIPLES

[Based on IS 15023 (Part 1) : 2001/ISO 5845-1 : 1995]

16.1 Scope

This section establishes general principles for the simplified representation of holes, bolts (screws), rivets, etc, on technical drawings.

16.2 Simplified Representation of Fasteners

16.2.1 Representation on Projection Planes Normal to the Axes of the Fasteners

In order to represent holes, bolts and rivets on projection planes normal to their axes, the symbolic representation shall be drawn in continuous wide line (01.2) in accordance with Section 6. The position of the fastener is indicated by a cross (see Fig. 16.1).

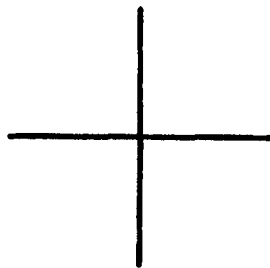


FIG. 16.1

Additional information should be indicated in accordance with Tables 16.1 and 16.2.

A prominent dot may be placed in the centre of the cross in order to facilitate the use of drawing copies as a template (see example in Fig. 16.2). The diameter of the dot shall be five times the thickness of the line used for indicating the cross.

16.2.2 Representation on Projection Planes Parallel to the Axes of the Fastener

In order to represent holes, bolts and rivets on projection planes parallel to their axes, the symbolic representation shown in Tables 16.2 and 16.3 shall be adopted. The horizontal line of this symbolic representation shall be drawn in a continuous narrow line (01.1); all other parts shall be drawn in a wide line (01.2), in accordance with Section 6.

16.3 Dimensioning

Dimension lines shall be terminated in accordance with Section 6.

16.3.1 The extension lines shall be separated from the symbolic representation of holes, bolts and rivets on projection planes parallel to their axes (see Fig. 16.2).

Table 16.1 Symbolic Representation of Holes, Bolts and Rivets to Fit in Holes
(Clause 16.2.1)

Hole ¹⁾ and bolt or rivet	Hole			
	without countersinking	countersunk on near side	countersunk on far side	countersunk on both sides
Drilled and fitted in the workshop	+	✳	✳	✳
Drilled in the workshop and fitted on site	✳	✳	✳	✳
Drilled and fitted on site	✳	✳	✳	✳

1) To distinguish bolts and rivets from holes, the correct designation of the hole or fastener shall be given

EXAMPLE

The designation for a hole of diameter 13 mm is $\varnothing 13$, the designation for a bolt with metric screw thread of diameter 12 mm and length 50 mm is M12 \times 50, while that for a rivet of diameter 12 mm and length 50 mm is $\varnothing 12 \times 50$.

Table 16.2 Symbolic Representation of Holes
(Clause 16.2.2)

Hole	Hole		
	without countersinking	countersunk on one side only	countersunk on both sides
Drilled in the workshop			
Drilled on site			

Table 16.3 Symbolic Representation of Bolts or Rivets to Fit in Holes
(Clause 16.2.2)

Bolt or rivet ¹⁾	Hole			Bolt with designated nut position
	without countersinking	countersunk on one side only	countersunk on both sides	
Fitted in the workshop				
Fitted on site				
Hole drilled on site and bolt or rivet fitted on site				

1) To distinguish bolts from rivets, the correct designation of the fastener shall be given.

EXAMPLE

The designation for a bolt with metric screw thread of diameter 12 mm and length 50 mm is M12 x 50, while that for a rivet of diameter 12 mm and length 50 mm is \varnothing 12 x 50.

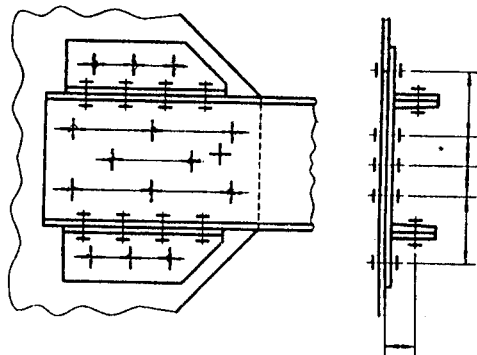


FIG. 16.2

16.3.2 The diameter of holes shall be indicated on a leader line pointing to the symbolic representation of a hole (see Fig. 16.3).

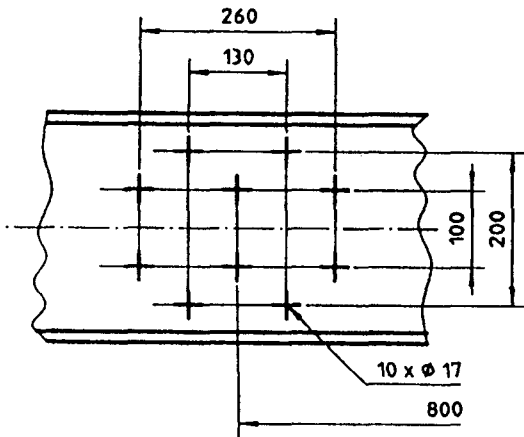


FIG. 16.3

16.3.3 To indicate the characteristics of bolts and rivets, their designations shall be given on a leader line pointing to the symbolic representation (see Fig. 16.4).

16.3.4 The designation of holes, bolts and rivets, when referring to a group of identical elements, can be restricted to one exterior element. In this case the designation shall be preceded by the number of holes, bolts or rivets constituting the group (see Fig. 16.3 and 16.4).

16.3.5 Holes, bolts and rivets equidistant from a centreline may be dimensioned as shown in Fig. 16.3 to 16.5.

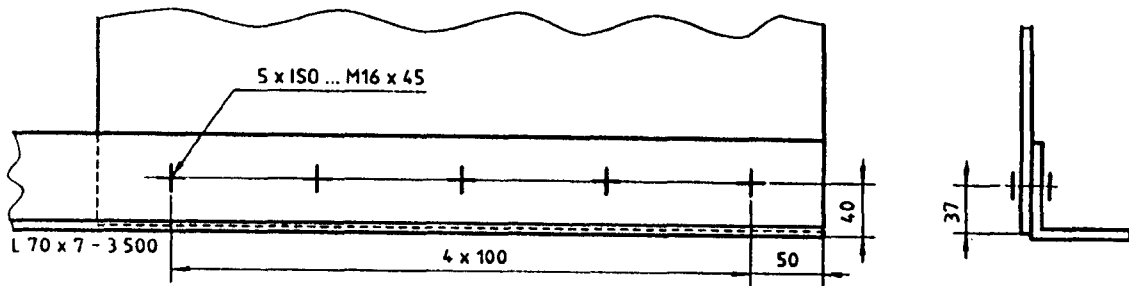


FIG. 16.4

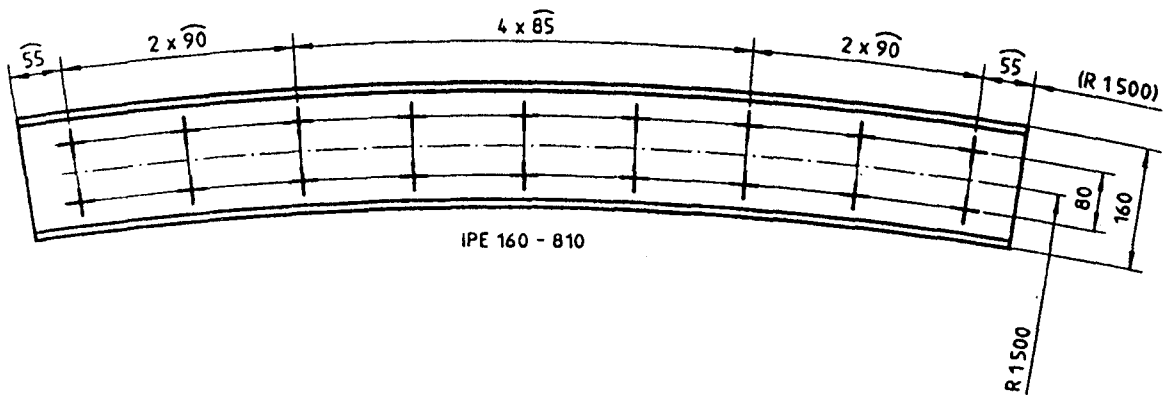


FIG. 16.5

SECTION 17 SIMPLIFIED REPRESENTATION OF BARS AND PROFILE SECTIONS

[Based on IS 10720 : 1999/ISO 5261 : 1995]

17.1 Scope

This section specifies rules for the simplified representation of bars and profile sections in assembly and detail drawings concerning, among others:

- structural metal work consisting of plates and sheets, profile sections and compound elements (including bridges, frameworks, pilings, etc);
- lifting and transport appliances;
- storage tanks and pressure vessels; and
- lifts, moving stairways and conveyor belts.

17.2 Complementary Rules for the Simplified Representation of Bars and Profile Sections

The simplified representation of bars and profile sections shall consist of their relevant IS designation followed, if necessary, by the cutting length, separated by a hyphen. This designation may also be used when filling in an item list (Section 2).

Example

The simplified representation of an equal leg angle profile in accordance with IS 808, measuring 50 mm × 50 mm × 4 mm and having a cutting length of 1 000 mm shall consist of the following IS designation:

Angle profile IS 808 - 50 × 50 × 4 - 1 000

If there is no designation specified in a standard, the designation shall be composed of the graphical symbol followed by the necessary dimensions, in accordance with Tables 17.1 and 17.2.

Table 17.1 applies to the designation of bar sections.

Example

The simplified representation of a rectangular solid bar section measuring 50 mm × 10 mm and having a


cutting length of 100 mm shall consist of the following designation:

□ 50 × 10 - 100

Table 17.2 applies to the designation of profile sections, and indicates which graphical symbols may be replaced by upper case letters, if appropriate, for simplification.

Example

The simplified representation of an angle profile section measuring 89 mm × 60 mm × 7 mm and having a cutting length of 500 mm shall consist of one of the following two designations:


 89 × 60 × 7 - 500
 or
 L 89 × 60 × 7 - 500

The designation shall be positioned in close proximity to the relevant item (*see* Fig. 17.1 to 17.3). Figure 17.3 includes L-shaped profiles for which the graphical symbols are positioned to reflect the arrangement for assembly.

17.3 Schematic Representation of Structural Metal Work

Compound frames of structural metal work can be schematically represented by continuous wide lines (01.2) indicating the centroidal lines of the intersecting elements. In this case, the values of the distances between the reference points of the centroidal lines shall be indicated directly on the represented elements (*see* Fig. 17.4).

Closed dimensional chains are permitted. However, in the case of cumulative tolerances, equalization via one of the dimensions shall be indicated.

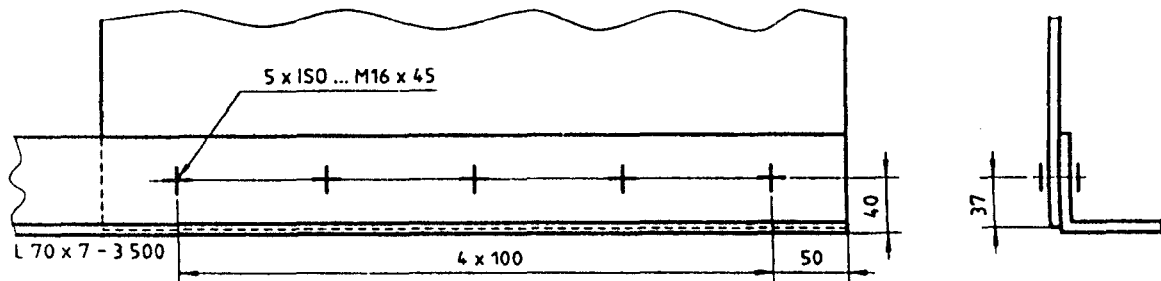


FIG. 17.1

Table 17.1 Graphical Symbols and Dimensions for Bar Sections
(Clause 17.2)









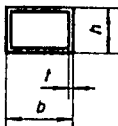


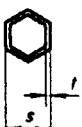


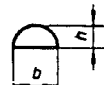










Description of bar section	Dimensions	Designation	
		Graphical symbol	Necessary dimensions
Circular solid section			d
Tube			$d \times t$
Square solid section			b
Square hollow section			$b \times t$
Rectangular solid section			$b \times h$
Rectangular hollow section			$b \times h \times t$
Hexagonal solid section			s
Hexagonal hollow section			$s \times t$
Triangular solid section			b
Semicircular solid section			$b \times h$

Table 17.2 Graphical Symbols and Dimensions for Profile Sections
(Clause 17.2)

Description of profile section	Designation		
	Graphical symbol	Alternative letter symbol	Dimensions
Angle section		L	Characteristic dimensions
T-section		T	
I-beam section		I	
H-beam section		H	
Channel section		U	
Z-section		Z	
Rail section			
Bulb angle section			
Bulb flat section			

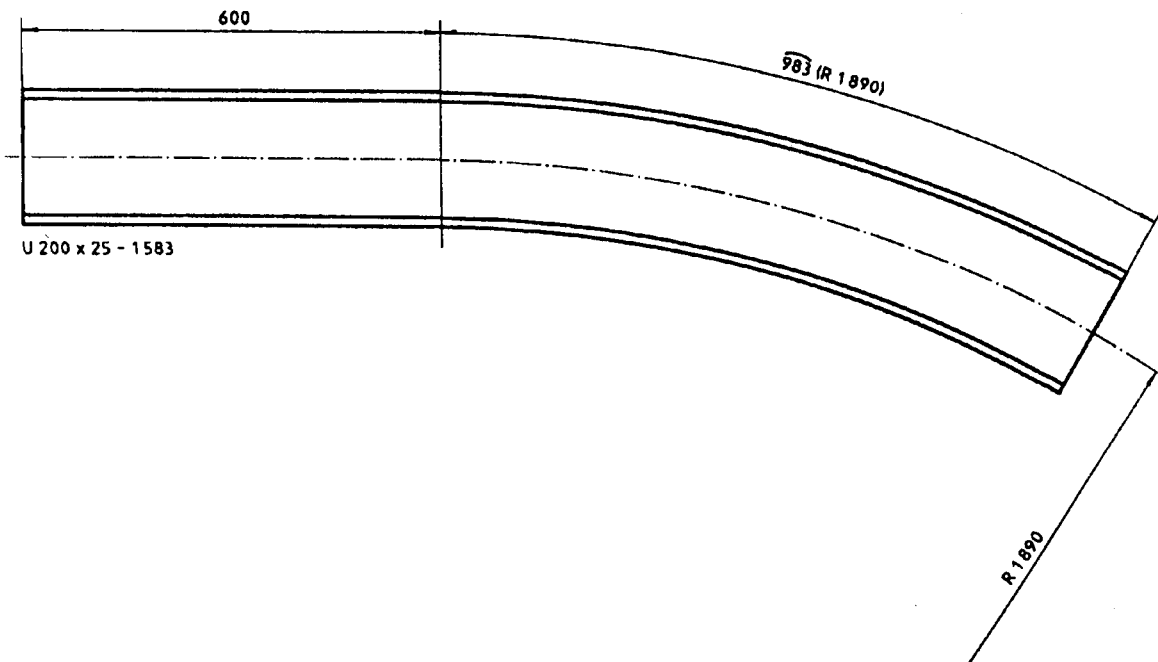


FIG. 17.2

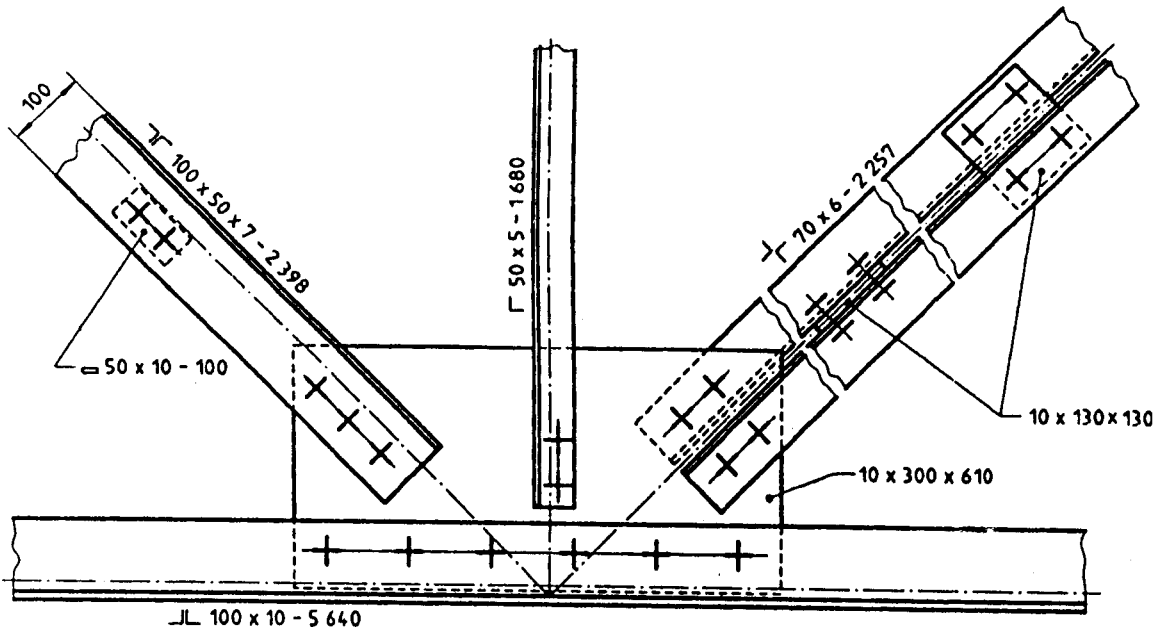


FIG. 17.3

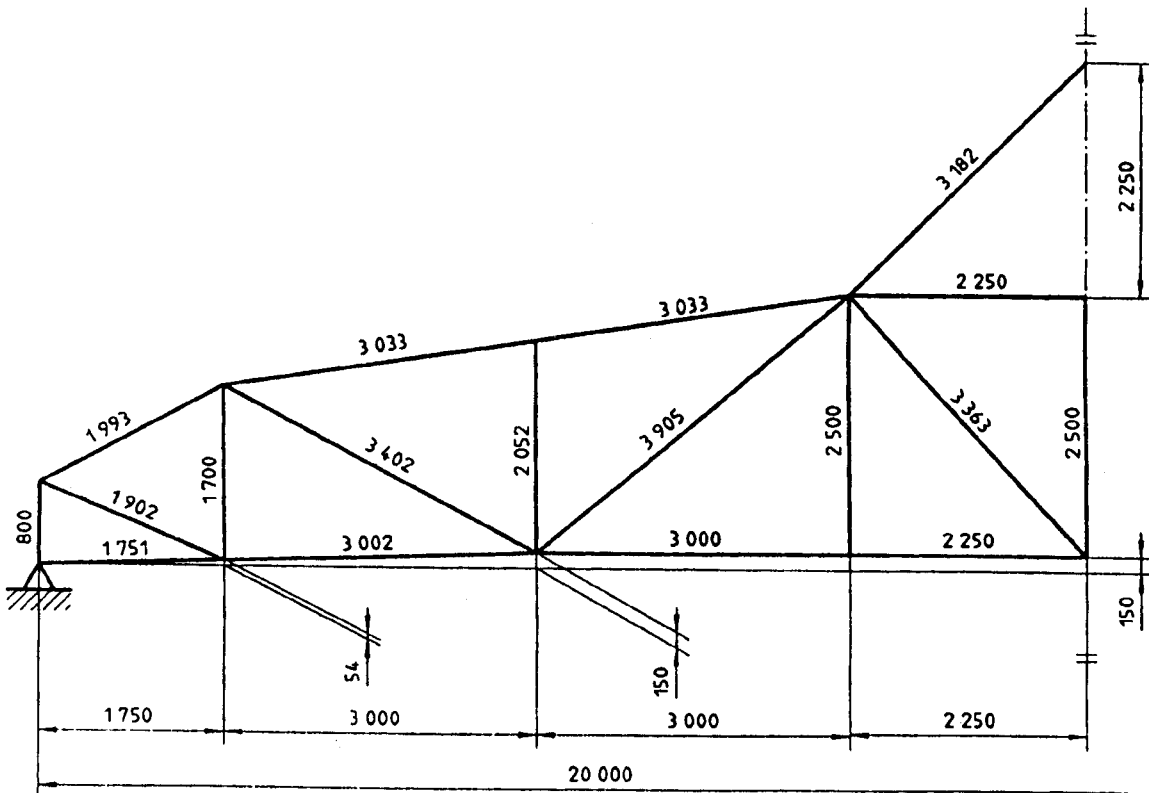


FIG. 17.4

SECTION 18 WELDED, BRAZED AND SOLDERED JOINTS — SYMBOLIC REPRESENTATION ON DRAWINGS

[Based on ISO 2553 : 1992]

18.1 Scope

This section prescribes the rules to be applied for the symbolic representation of welded, brazed and soldered joints on drawings.

18.2 General

18.2.1 Joints may be indicated with the general recommendations for technical drawings. However, for the purpose of simplification, it is advisable to adopt, for usual joints, the symbolic representation described in this section.

18.2.2 The symbolic representation shall give clearly all necessary indications regarding the specific joint to be obtained without over-burdening the drawing with notes or showing an additional view.

18.2.3 This symbolic representation includes an elementary symbol which may be completed by

- a supplementary symbol;
- a means of showing dimensions;
- some complementary indications (particularly for workshop drawings).

18.2.4 In order to simplify the drawings as much as possible it is recommended that references be made to specific instructions or particular specifications giving all details of the preparation of edges to be welded, brazed and soldered and/or welding, brazing and soldering procedures, rather than showing these indications on the drawings of the welded parts.

If there are no such instructions, the dimensions relating to the preparation of the edges to be welded, brazed and soldered and/or welding, brazing and soldering procedures can be close to the symbol.

18.3 Symbols

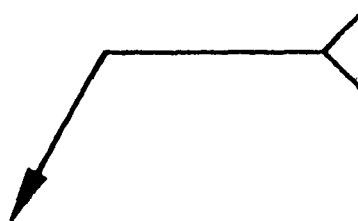
18.3.1 Elementary Symbols

The various categories of joints are characterized by a symbol which, in general, is similar to the shape of the weld to be made.

The symbol shall not be taken to prejudge the process to be employed.

The elementary symbols are shown in Table 18.1. If the joint should not be specified but only be represented that the joint will be welded, brazed or soldered, the following symbol shall be used:

18.3.2 Combinations of Elementary Symbols



When required, combinations of elementary symbols can be used.

The elementary symbols are to be combined for welding from both sides in such a manner arranging the applicable elementary symbols symmetrical to the reference line. Typical examples are given in Table 18.2 and applications for symbolic representation are given in Table 18.7.

18.3.3 Supplementary Symbols

Elementary symbols may be completed by a symbol characterizing the shape of the external surface or the shape of the weld.

The recommended supplementary symbols are given in Table 18.3.

The absence of a supplementary symbol means that the shape of the weld surface does not need to be indicated precisely.

Examples of combinations of elementary and supplementary symbols are given in Table 18.4.

NOTE — Although it is not forbidden to associate several symbols, it is better to represent the weld on a separate sketch when symbolization becomes too difficult.

Table 18.4 gives examples of application of the supplementary symbols.

Table 18.1 Elementary Symbols
(Clauses 18.3.1 and 18.4.3)

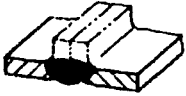













No.	Designation	Illustration	Symbol
1	Butt weld between plates with raised edges ¹⁾ ; edge flanged weld /USA/ (the raised edges being melted down completely)		
2	Square butt weld		
3	Single-V butt weld		
4	Single-bevel butt weld		
5	Single-V butt weld with broad root face		
6	Single-bevel butt weld with broad root face		
7	Single-U butt weld (parallel or sloping sides)		

Table 18.1 Elementary Symbols — (Continued)





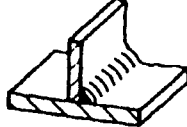



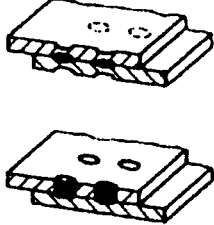

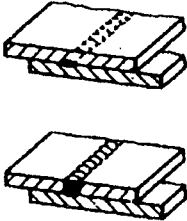









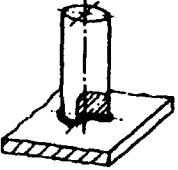






No.	Designation	Illustration	Symbol
8	Single-J butt weld		
9	Backing run; back or backing weld /USA/		
10	Fillet weld		
11	Plug weld; plug or slot weld /USA/		
12	Spot weld		
13	Seam weld		
14	Steep-flanked single-V butt weld		
15	Steep-flanked single-bevel butt weld		

Table 18.1 Elementary Symbols — (Concluded)

No.	Designation	Illustration	Symbol
16	Edge weld		
17	Surfacing		
18	Surface joint		
			
19	Inclined joint		
20	Fold joint		

1) Butt welds between plates with raised edges (symbol 1) not completely penetrated are symbolized as square butt welds (symbol 2) with the weld thickness s shown (see Table 18.5)

Table 18.2 Combined Symbols for Symmetrical Welds (Examples)
(Clause 18.3.2)

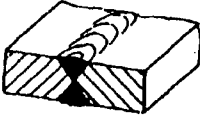
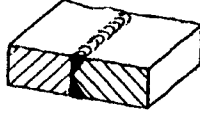
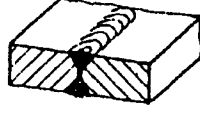
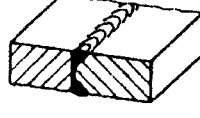
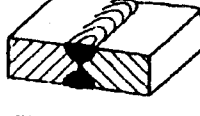
Designation	Illustration	Symbol
Double-V butt weld (X weld)		X
Double-bevel butt weld		K
Double-V butt weld with broad root face		Y
Double-bevel butt weld with broad root face		K
Double-U butt weld		U

Table 18.3 Supplementary Symbols
(Clause 18.3.3)






Shape of weld surface or weld	Symbol
a) Flat (usually finished flush)	—
b) Convex	
c) Concave	
d) Toes shall be blended smoothly	
e) Permanent backing strip used	
f) Removable backing strip used	

Table 18.4 Examples of Application of Supplementary Symbols
(Clause 18.3.3)

Designation	Illustration	Symbol
Flat (flush) single-V butt weld		
Convex (double-V) weld		
Concave fillet weld		
Flat (flush) single-V butt weld with flat (flush) backing run		
Single-V butt weld with broad root face and backing run		
Flush finished single-V butt weld		
Fillet weld with smooth blended face		

¹⁾ Symbol in accordance with ISO 1302; instead of this symbol the main symbol $\sqrt{\quad}$ can be used.

18.4 Position of the Symbols on Drawings

18.4.1 General

The symbols covered by these rules form only part of the complete method of representation (Fig. 18.1), which comprises in addition to the symbol (3) itself:

- an arrow line (1) per joint (see Fig. 18.2 and Fig. 18.3);
- a dual reference line, consisting of two parallel lines, one continuous and one dashed (2) (exception, see Note);
- a certain number of dimensions and conventional signs.

NOTES

1 The dashed line can be drawn either above or beneath the continuous line (see also 18.4.5).

2 For symmetrical welds, the dashed line is unnecessary and should be omitted.

The purpose of the following rules is to define the location of welds by specifying

- the position of the arrow line;

- the position of the reference line; and
- the position of the symbol.

The arrow line and the reference line form the complete reference mark. If details are given, for example, for processes, acceptance levels, position, filler and auxiliary materials (see 18.6), a tail shall be added at the end of the reference line.

18.4.2 Relationship Between the Arrow Line and the Joint

The examples given in Fig. 18.2 and Fig. 18.3 explain the meaning of the terms

- 'Arrow side' of the joint; and
- 'Other side' of the joint.

NOTES

1 The position of the arrow in these figures is chosen for purposes of clarity. Normally, it would be placed immediately adjacent to the joint.

2 See Fig. 18.2.

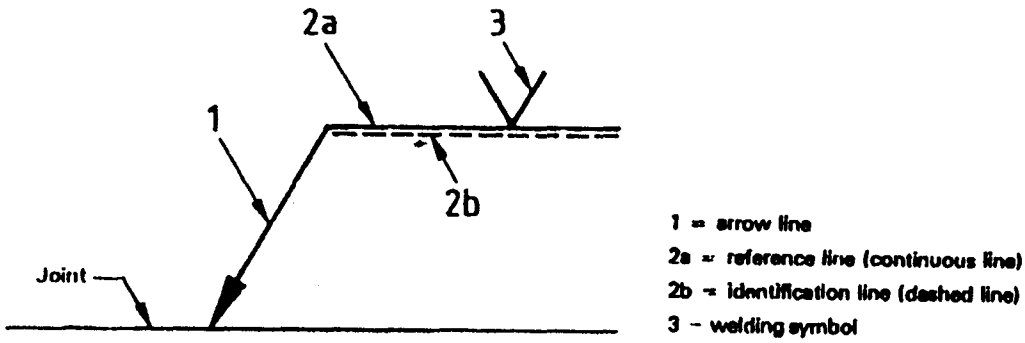


FIG. 18.1 METHOD OF REPRESENTATION

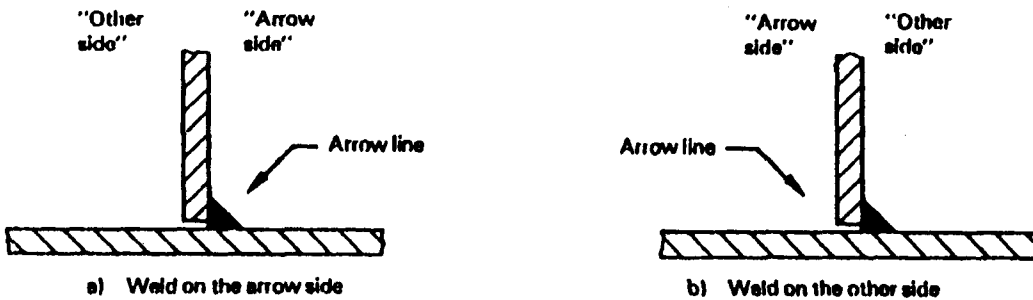


FIG. 18.2 T-JOINT WITH ONE FILLET WELD

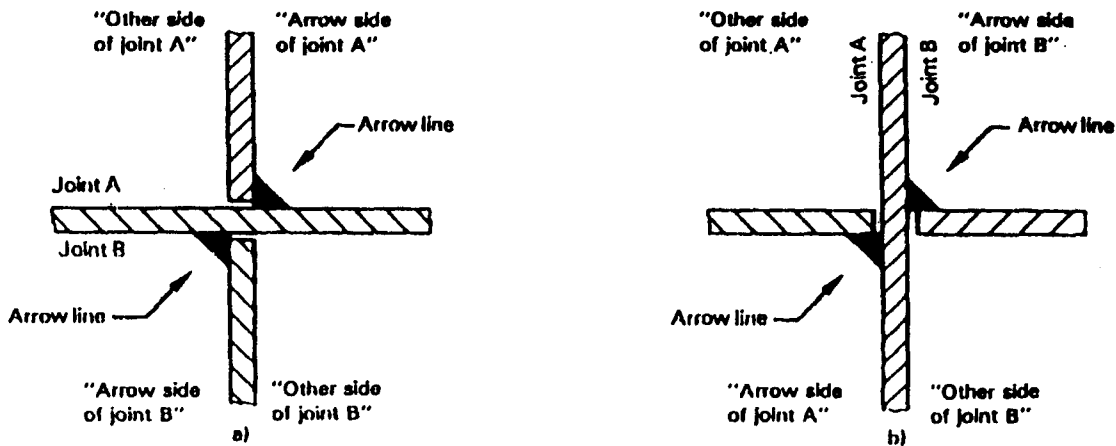


FIG. 18.3 CRUCIFORM JOINT WITH TWO FILLET WELDS

18.4.3 Position of the Arrow Line

The position of the arrow line with respect to the weld is generally of no special significance [see Fig. 18.4 (a) and 18.4 (b)]. However, in the case of welds of types 4, 6 and 8 (see Table 18.1), the arrow line shall point towards the plate which is prepared [see Fig. 18.4 (c) and 18.4 (d)].

The arrow line

- joins one end of the continuous reference line such that it forms an angle with it; and
- shall be completed by an arrow head.

18.4.4 Position of the Reference Line

The reference line shall preferably be drawn parallel to the bottom edge of the drawing, or if impossible perpendicular.

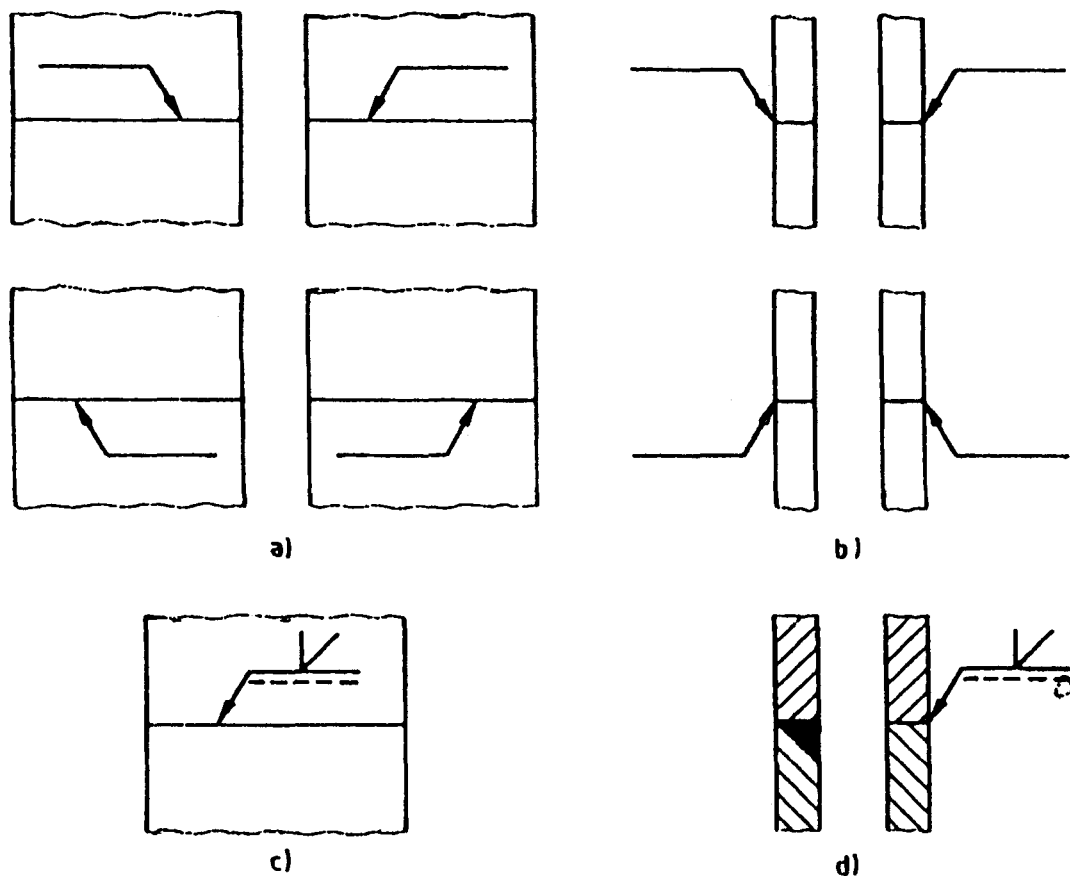


FIG. 18.4 POSITION OF THE ARROW LINE

18.4.5 Position of the Symbol with Regard to the Reference Line

The symbol is to be placed either above or beneath the reference line, in accordance with the following regulation:

- The symbol is placed on the continuous line side of the reference line if the weld (weld face) is on the arrow side of the joint [see Fig. 18.5 (a)].
- The symbol is placed on the dashed line side if the weld (weld face) is on the other side of the joint [see Fig. 18.5 (b)].

NOTE — In the case of spot welds made by projection welding, the projection surface is to be considered as the external surface of the weld.

18.5 Dimensioning of Welds

18.5.1 General Rules

Each weld symbol may be accompanied by a certain number of dimensions.

These dimensions are written as follows, in accordance with Fig. 18.6:

- a) the main dimensions relative to the cross-section are written on the left-hand side of (that is, before) the symbol;
- b) longitudinal dimensions are written on the right-hand side of (that is, after) the symbol.

The method of indicating the main dimensions is defined in Table 18.5. The rules for setting down these dimensions are also given in Table 18.5.

Other dimensions of less importance may be indicated if necessary.

18.5.2 Main Dimensions to be Shown

The dimension that locates the weld in relation to the edge of the sheet shall not appear in the symbolization but on the drawing.

18.5.2.1 The absence of any indication following the symbol signifies that the weld is to be continuous over the whole length of the workpiece.

18.5.2.2 In the absence of any indication to the contrary, butt welds are to have complete penetration.

18.5.2.3 For the fillet welds there are two methods to indicate dimensions (see Fig. 18.7). Therefore, the

letters *a* or *z* shall always be placed in front of the value of the corresponding dimension as follows:

To indicate deep penetration of fillet welds the throat thickness is *s*, (see Fig. 18.8).

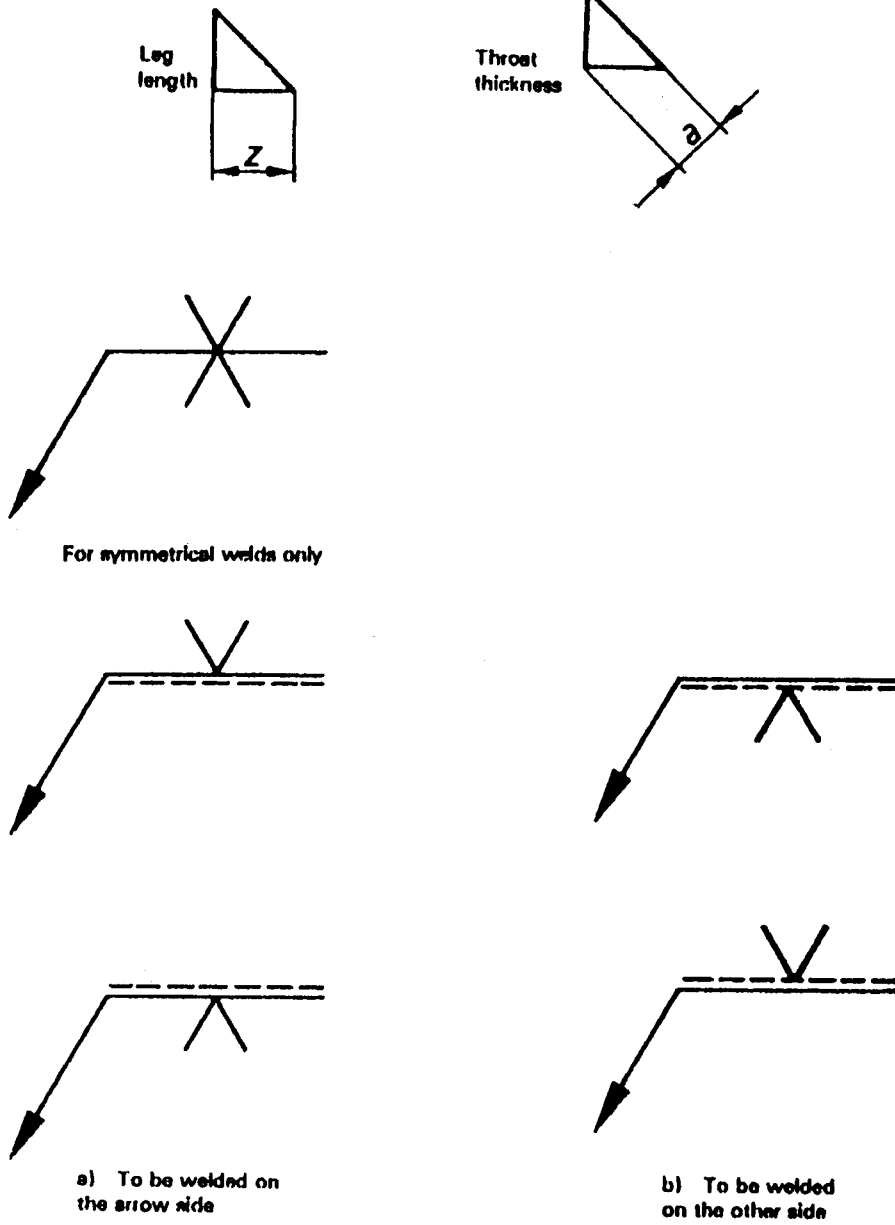


FIG. 18.5 POSITION OF THE SYMBOL ACCORDING TO THE REFERENCE LINE

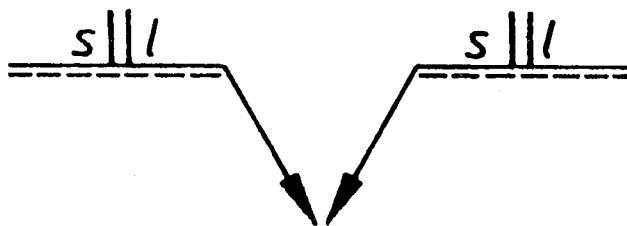


FIG. 18.6 EXAMPLES OF THE PRINCIPLE

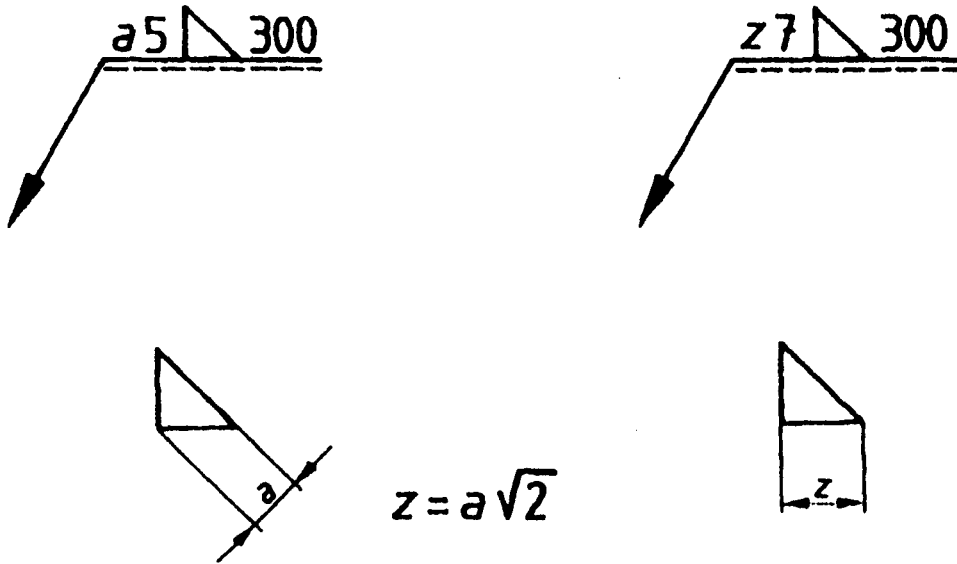
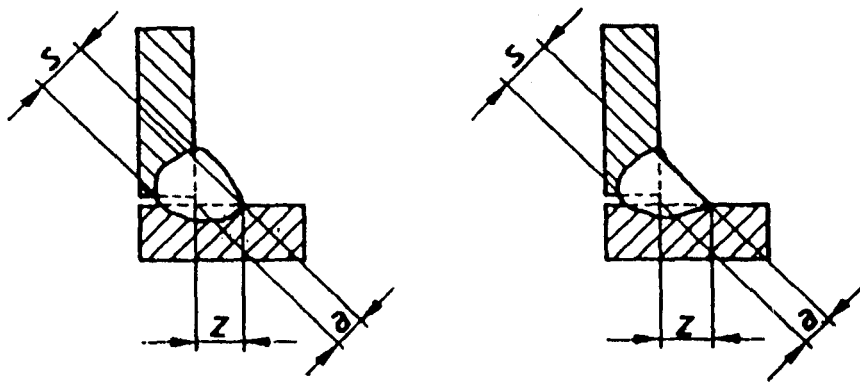


FIG. 18.7 METHODS OF INDICATING DIMENSIONS FOR FILLET WELDS



NOTE — For deep penetration of welds, the dimensions are indicated as $s\ a\ \Delta$, for example.

FIG. 18.8 METHODS OF INDICATING DIMENSIONS FOR DEEP PENETRATION OF FILLET WELDS

18.5.2.4 In the case of plug or slot welds with bevelled edges, it is the dimension at the bottom of the hole which shall be taken into consideration.

18.6 Complementary Indications

Complementary indications may be necessary in order to specify some other characteristics of welds. For example:

18.6.1 Peripheral Welds

When the weld is to be made all around a part, the symbol is a circle, as shown in Fig. 18.9.

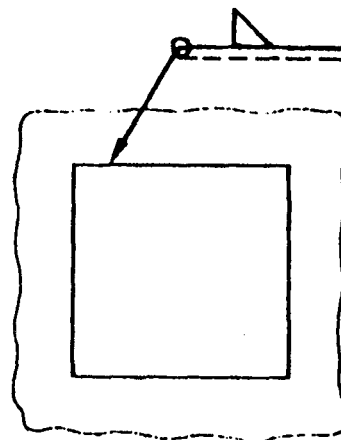


FIG. 18.9 INDICATION OF PERIPHERAL WELD

Table 18.5 Main Dimensions
(Clause 18.5.2.4)









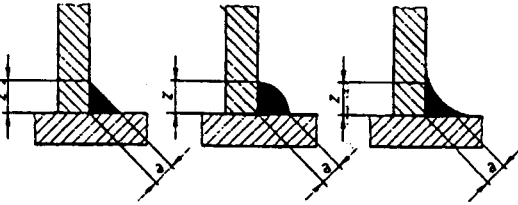


No.	Designation of welds	Illustration	Definition	Inscription
1	Butt weld		s : minimum distance from the surface of the part to the bottom of the penetration, which cannot be greater than the thickness of the thinner part.	 (see 18.5.2.1 and 18.5.2.2)
				 (see 18.5.2.1)
				 (see 18.5.2.1)
2	Butt weld between plates with raised edges		s : minimum distance from the external surface of the weld to the bottom of the penetration.	 [see 18.5.2.1 and footnote 1) to Table 18.1]
3	Continuous fillet weld		a : height of the largest isosceles triangle that can be inscribed in the section. z : side of the largest isosceles triangle that can be inscribed in the section.	  (see 18.5.2.1 and 18.5.2.3)
			4	Intermittent fillet weld

Table 18.5 Main Dimensions — (Concluded)

No.	Designation of welds	Illustration	Definition	Inscription
5	Staggered intermittent fillet weld		$l :$ $(e) :$ $n :$ $a :$ $z :$ (see No. 4) (see No. 3)	$\frac{a}{a} \triangleright \frac{n \times l}{n \times l} \left[\frac{e}{e} \right]$ $\frac{z}{z} \triangleright \frac{n \times l}{n \times l} \left[\frac{e}{e} \right]$ (see 18.5.2.3)
6	Plug or slot weld		$l :$ $(e) :$ $n :$ $c :$ (see No. 4) width of slot	$c \left[\frac{n \times l}{n \times l} \right] \left[\frac{e}{e} \right]$ (see 18.5.2.4)
7	Seam weld		$l :$ $(e) :$ $n :$ $c :$ (see No. 4) width of weld	$c \bigcirc \frac{n \times l}{n \times l} \left[\frac{e}{e} \right]$
8	Plug weld		$n :$ $(e) :$ $d :$ (see No. 4) spacing diameter of hole	$d \left[\frac{n \times l}{n \times l} \right] \left[\frac{e}{e} \right]$
9	Spot weld		$n :$ $(e) :$ $d :$ (see No. 4) spacing diameter of spot	$d \bigcirc \frac{n \times l}{n \times l} \left[\frac{e}{e} \right]$

18.6.2 Field or Site Welds

A flag is to be used to indicate the field or site weld, as shown in Fig. 18.10.

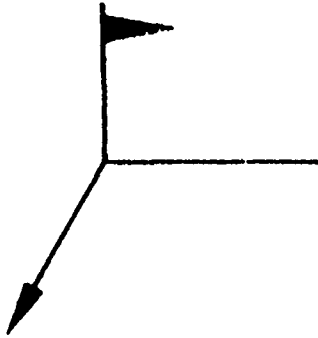


FIG. 18.10 INDICATION OF FIELD OR SITE WELD

18.6.3 Indication of the Welding Process

If required, the welding process is to be symbolized by a number written between the two branches of a fork, at the end of the reference line remote from the reference line.

Figure 18.11 gives an example of its use.

The list giving the correspondence between the numbers and the process is given in ISO 4063.

18.6.4 Sequence of Information in the Tail of the Reference Mark

The information for joints and the dimensions can be supplemented by further information in the tail, in the following order:

- process (for example, in accordance with ISO 4063);
- acceptance level [for example, in accordance with IS 7307 (Part 1) and IS 3613];
- working position (for example, in accordance with ISO 6947);
- filler materials (for example, in accordance with ISO 544, ISO 2560, ISO 3581).



FIG. 18.11 INDICATION OF WELDING PROCESS

The individual items are to be separated by / (solidus).

In addition, a closed tail is possible which indicates specific instruction (for example, procedure sheet) by a reference sign, see Fig. 18.12.

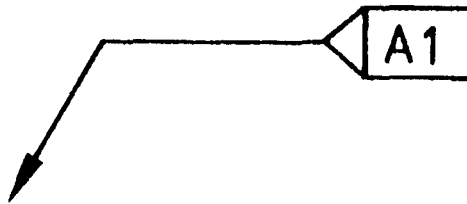


FIG. 18.12 REFERENCE INFORMATION

Example

Single V-butt weld with backing run (see Fig. 18.13), produced by manual metal-arc welding (reference number 111 in accordance with ISO 4063), required acceptance level in accordance with ISO 5817, flat position PA in accordance with ISO 6947, covered electrode ISO 2560-E 51 2 RR 22.

18.7 Examples for Application of Spot and Seam Joints

In the case of seam and spot joints (welded, brazed or soldered), joints are made at the interface between the two lapped parts or by melt-through of one of the two parts (see Fig. 18.14 and Fig. 18.15).

18.8 Examples of Use of Symbols

Tables 18.6 and 18.7 give some examples of the use of symbols. The representations shown are given simply for explanation.

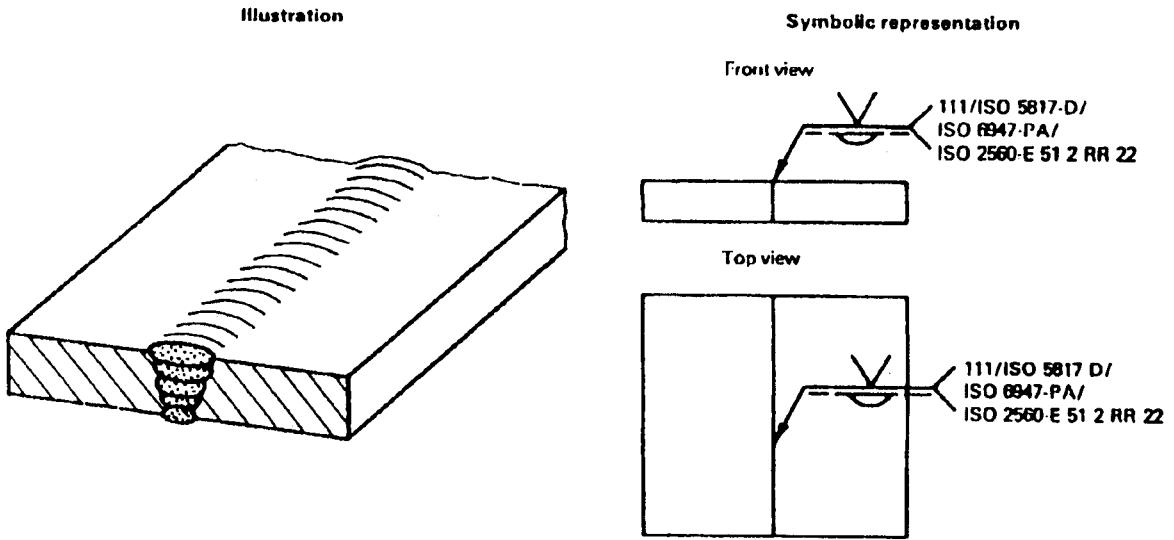


FIG. 18.13 SINGLE V-BUTT WELD WITH BACKING RUN

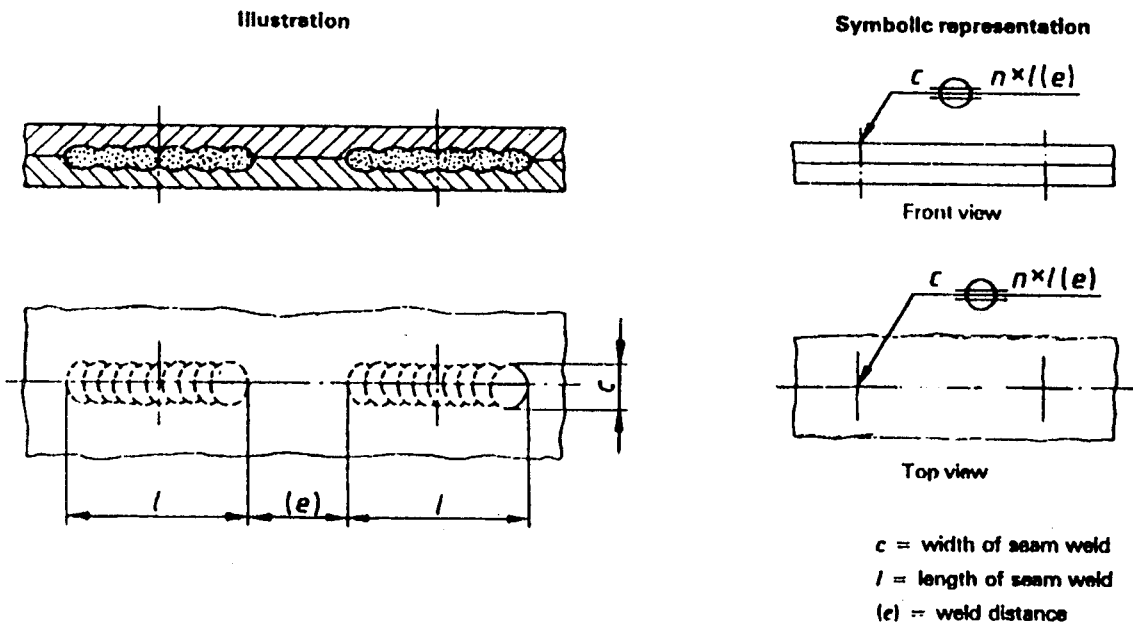
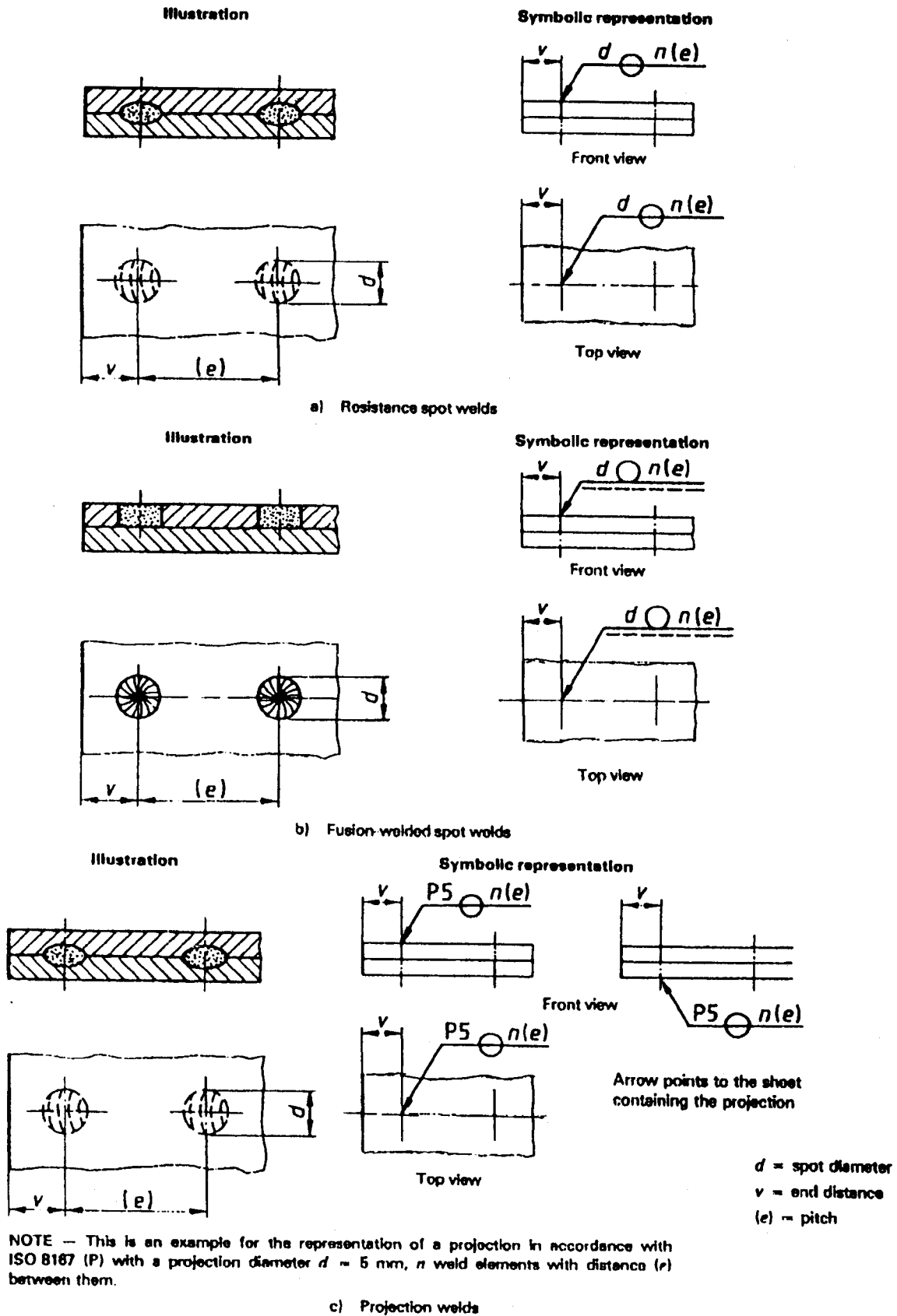


FIG. 18.14 INTERMITTENT RESISTANCE SEAM WELDS



NOTE — This is an example for the representation of a projection in accordance with ISO 8187 (P) with a projection diameter $d = 5$ mm, n weld elements with distance (e) between them.

FIG. 18.15 SPOT WELDS

Table 18.6 Examples of the Use of Elementary Symbols
(Clause 18.8)

No.	Designation Symbol (Numbers refer to Table 18.1)	Illustration	Representation	Symbolization	
				either	or
1					
2					
3	Square butt weld 				
4					

Table 18.6 — (Continued)



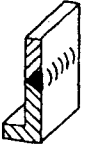
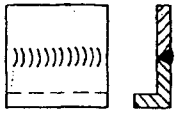
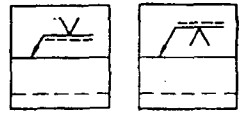
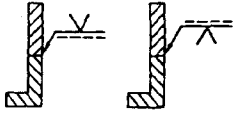
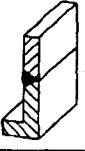

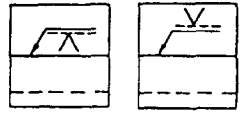
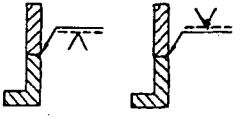

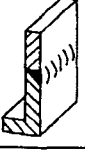
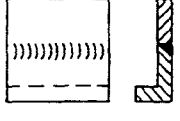
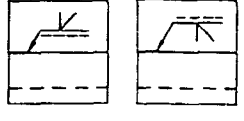
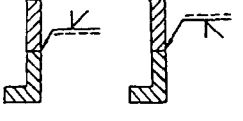
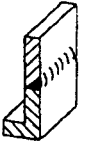
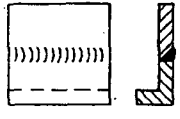

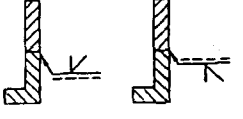
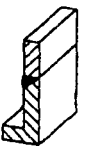
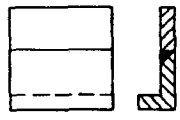
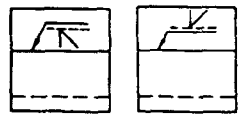
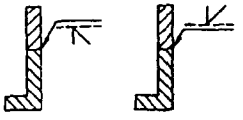
No.	Designation Symbol (Numbers refer to Table 18.1)	Illustration	Representation 	Symbolization	
				either	or
5	Single-V butt weld 				
6					
7	Single-bevel butt weld 				
8					
9					

Table 18.6 — (Continued)




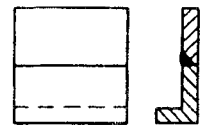
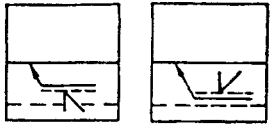
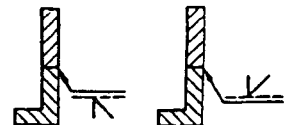

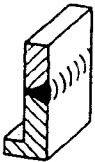
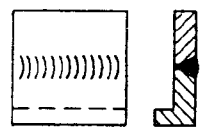
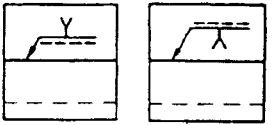
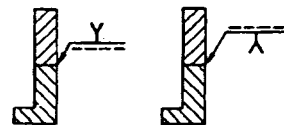
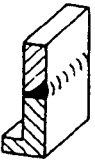
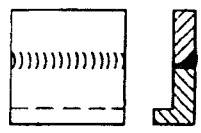
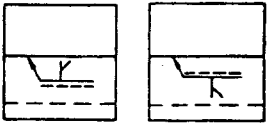
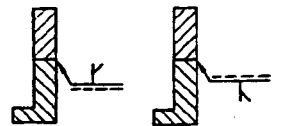

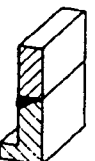




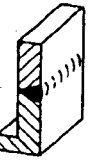
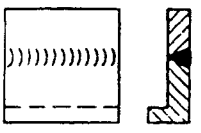
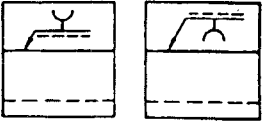
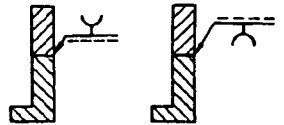
No.	Designation Symbol (Numbers refer to Table 18.1)	Illustration	Representation 	Symbolization	
				either	or
10	Single-bevel butt weld 				
11	Single-V butt weld with broad root face 				
12	Single-bevel butt weld with broad root face				
13					
14	Single-U butt weld 				

Table 18.6 — (Continued)

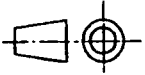

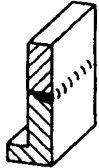
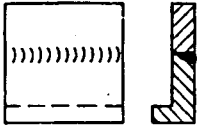
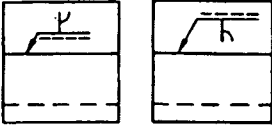
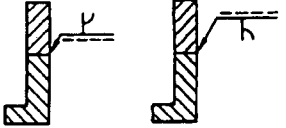

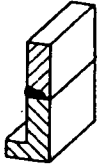

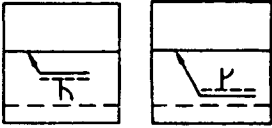


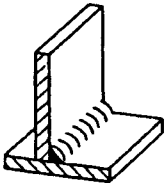
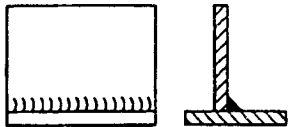
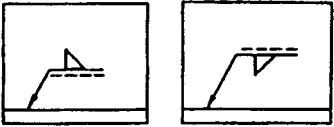
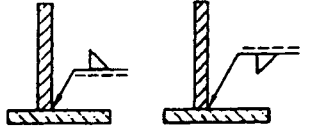

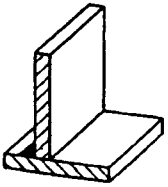
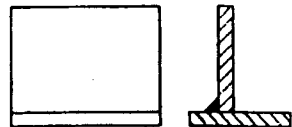
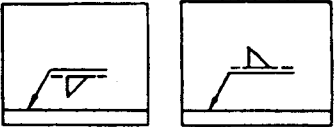
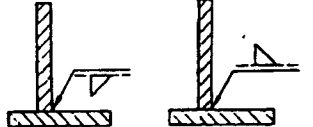
No.	Designation Symbol (Numbers refer to Table 18.1)	Illustration	Representation 	Symbolization	
				either	or
15	Single-J butt weld 				
16					
17	Fillet weld 				
18					

Table 18.6—(Continued)

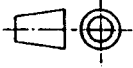

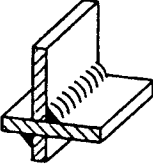
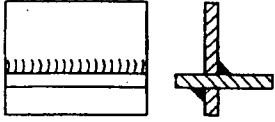
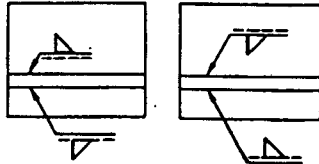
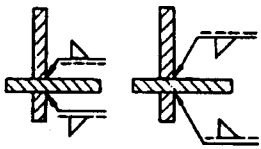
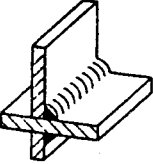
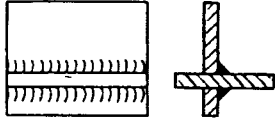
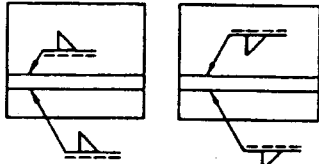
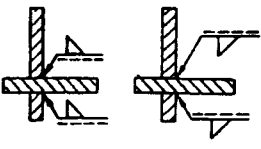
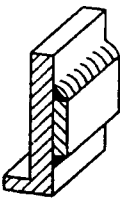
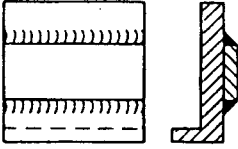
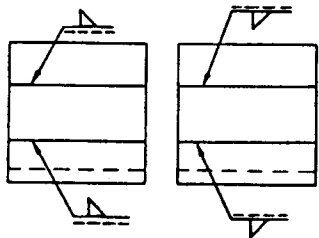
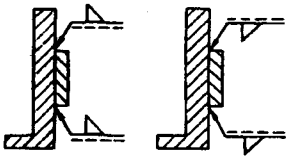
No.	Designation Symbol (Numbers refer to Table 18.1)	Illustration	Representation 	Symbolization	
				either	or
19	Fillet weld 				
20					
21					

Table 18.6 — (Continued)

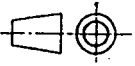
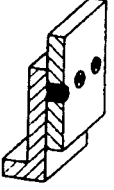
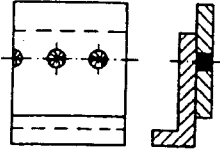
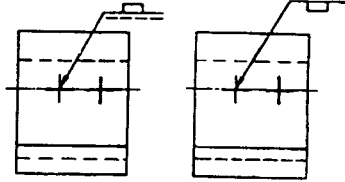
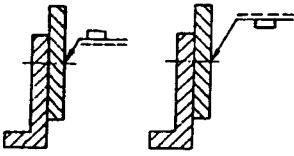
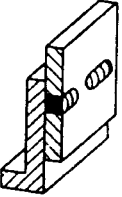
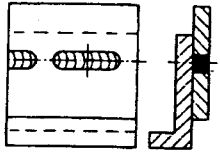
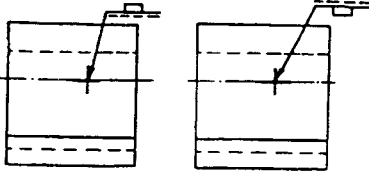
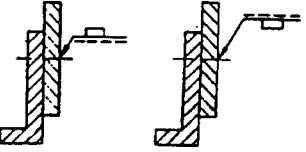
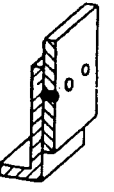
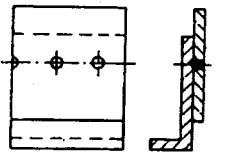
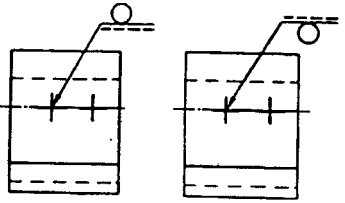
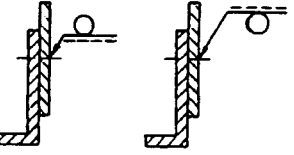
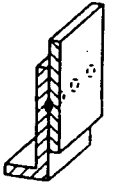
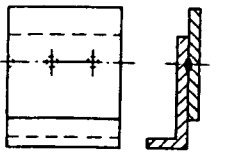
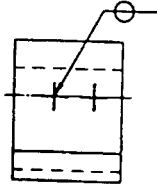
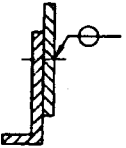
No.	Designation Symbol (Numbers refer to Table 18.1)	Illustration	Representation 	Symbolization	
				either	or
22	Plug weld 11				
23					
24	Spot weld 12				
25					

Table 18.6 — (Concluded)

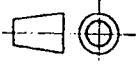

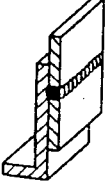
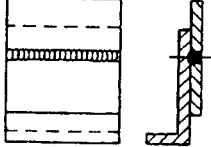
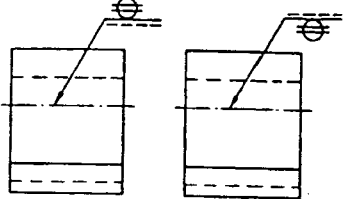
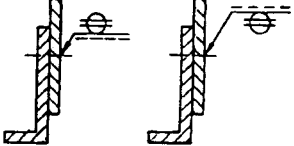

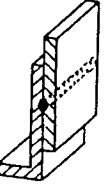
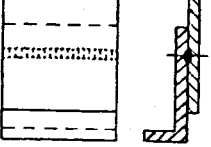
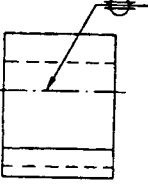
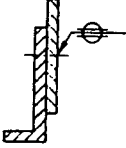


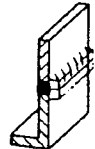
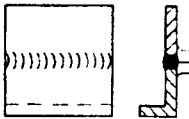
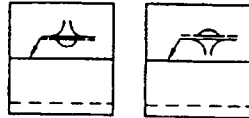
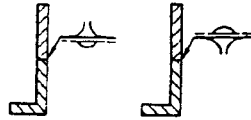
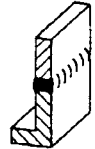
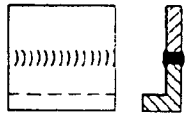
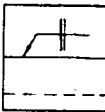
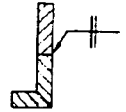

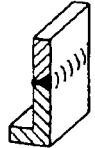
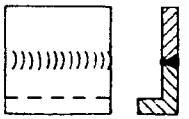
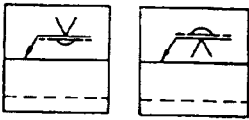
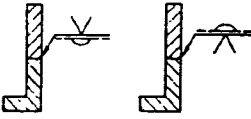

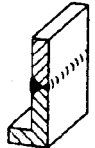
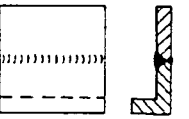
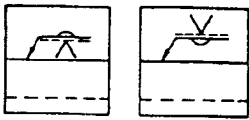
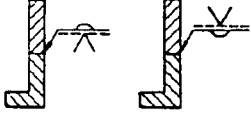
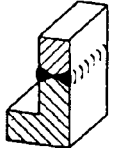
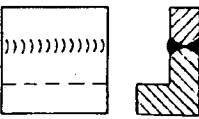
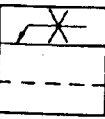
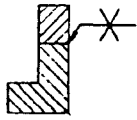
No.	Designation Symbol (Numbers refer to Table 18.1)	Illustration	Representation 	Symbolization	
				either	or
26	Seam weld 				
27	13 				

Table 18.7 Examples of Combinations of Elementary Symbols
(Clauses 18.3.2 and 18.8)

No.	Designation Symbol (Numbers refer to Table 18.1)	Illustration	Representation	Symbolization	
				either	or
1	Butt weld between plates with raised edges  1 and backing run  9 1-9				
2	Square butt weld welded from both sides 2-2				
3	Single-V butt weld and backing run  3				
4	 9 3-9				
5	Double-V butt weld (X weld) 3-3				

SECTION 19 EXAMPLES OF INDICATION AND INTERPRETATION OF GEOMETRICAL TOLERANCING SYMBOLS AND CHARACTERISTICS

[Based on IS 8000 (Part 1) : 1985/ISO 1101 : 1983]

19.1 Scope

This section incorporates the examples of indication and interpretation of geometrical tolerancing symbols and characteristics.

19.2 Form tolerances limit the deviations of an individual feature from its ideal geometrical form.

19.3 Orientation, location and run-out tolerances limit the deviations of the mutual orientation and/or location of two or more features. For functional reasons one or more features may be indicated as a datum (*see* Fig. 19.1 and 19.2). If necessary, a geometrical tolerance should be specified to the datum feature in order to ensure that the datum feature is sufficiently exact for its purpose.

19.4 The geometrical tolerance applies always to the whole extent of tolerated feature unless otherwise

specified, for example, 0.02/50 indicates that a tolerance of 0.02 is permitted for an extent of 50 at any place on the tolerated feature (*see* Fig. 19.3).

19.5 When a geometrical tolerance applies to an axis or a median plane, then the arrow of the leader line terminates at the dimension line (*see* Fig. 19.4).

19.6 When a geometrical tolerance applies to a line or surface itself, then the leader line with its arrow terminating on the contour of the feature has to be clearly separated from the dimension line (*see* Fig. 19.5).

19.7 The same method of indication is used for the datum triangle (*see also* Fig. 19.6, 19.7 and 19.8). Table 19.1 gives some examples of indication and interpretation of geometrical tolerancing symbols and characteristics.

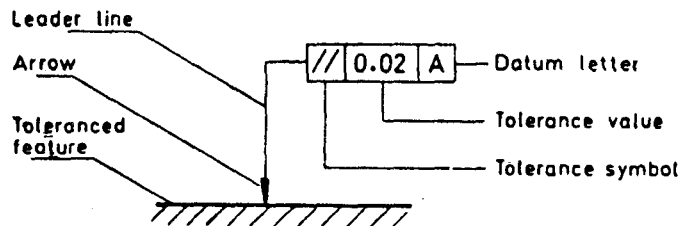


FIG. 19.1

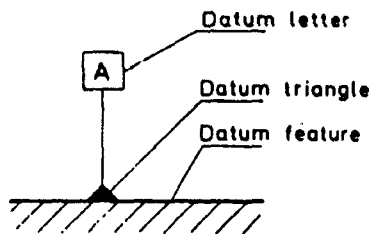


FIG. 19.2



FIG. 19.3

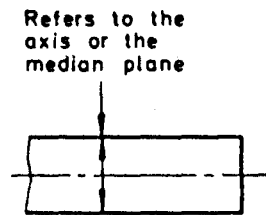


FIG. 19.4

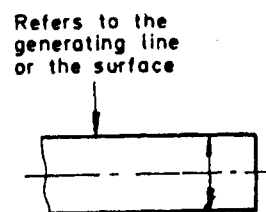


FIG. 19.5



FIG. 19.6



FIG. 19.7



FIG. 19.8

Table 19.1 Examples of Indication and Interpretation of Geometrical Tolerancing Symbols and Characteristics
(Clause 19.7)

All dimensions in millimetres.

Symbols and tolerated characteristics		Examples of indication and interpretation			
		Indication on the drawing	Tolerance zone	Interpretation	
Single features	Form tolerances	— Straightness			The axis of the cylinder, to which the tolerance frame is connected, shall be contained in a cylindrical zone of diameter 0.08.
		▭ Flatness			The surface shall be contained between two parallel planes 0.08 apart.
		○ Circularity			The circumference of each cross-section shall be contained between two co-planar concentric circles 0.1 apart.
		⊘ Cylindricity			The considered surface shall be contained between two coaxial cylinders 0.1 apart.
Single or related features		⌒ Profile of any line			In each section parallel to the plane of projection, the considered profile shall be contained between two lines enveloping circles of diameter 0.04, the centres of which are situated on a line having the true geometrical profile.
		⌒ Profile of any surface			The considered surface shall be contained between two surfaces enveloping spheres of diameter 0.02, the centres of which are situated on a surface having the true geometrical form.
Related features	Orientation tolerances	// Parallelism of a line (axis) with reference to a datum line			The tolerated axis shall be contained in a cylindrical zone of diameter 0.03, parallel to the datum axis A (datum line).
		⊥ Perpendicularity of a line (axis) with reference to a datum surface			The axis of the cylinder, to which the tolerance frame is connected, shall be contained between two parallel planes 0.1 apart, perpendicular to the datum surface.
		∠ Angularity of a line (axis) with reference to a datum surface			The axis of the hole shall be contained between two parallel planes 0.08 apart which are inclined at 60° to the surface A (datum surface).
	Location tolerances	⊕ Position of a line			The axis of the hole shall be contained within a cylindrical zone of diameter 0.08, the axis of which is in the theoretically exact position of the considered line, with reference to the surfaces A and B (datum planes).
		◎ Coaxiality of an axis			The axis of the cylinder, to which the tolerance frame is connected, shall be contained in a cylindrical zone of diameter 0.08 coaxial with the datum axis A-B.
		≡ Symmetry of a median plane			The median plane of the slot shall be contained between two parallel planes, which are 0.08 apart and symmetrically disposed about the median plane with respect to the datum feature A.
	Run-out tolerances	↗ Circular run-out radial			The radial run-out shall not be greater than 0,1 in any plane of measurement during one revolution about the datum axis A-B.
		↗ Total run-out radial			The total radial run-out shall not be greater than 0,1 at any point on the specified surface during several revolutions about the datum axis A-B, and with relative axial movement between part and measuring instrument. The movement shall be guided along a line having a theoretically perfect form of the contour and being in correct position to the datum axis.

SECTION 20 ABBREVIATIONS

20.1 Scope

This section covers such of the abbreviations which are recommended for use in general engineering drawings. Abbreviations already covered in specific subjects, such as, units and quantities, tolerancing, gears, fluid power, electrical and electronics are not dealt in this section.

20.2 Common Abbreviation

Abbreviations are the same both for singular and plural usage. Only capital letters are used for abbreviations to ensure maintenance of legibility bearing in mind reproduction and reduction processes. Abbreviations which have already been standardized nationally/internationally using lower case letters should, however, be written according to the corresponding standard. Table 20.1 lists some of the common abbreviations recommended.

20.2.1 When using abbreviations and symbols in engineering drawings, the following points are to be borne in mind.

- a) They should be used sparingly only when space saving in a drawing is essential.
- b) Short words such as 'day', 'unit', 'time', etc, should preferably be written in full, even when an abbreviation has been standardized.
- c) Periods (full stop symbol) are not to be used except where the abbreviation marks a word (for example, No., Fig.).
- d) For hyphenated words, abbreviations are to be with the hyphen.
- e) Sometimes one and the same letter symbol may represent more than one term or quantity. Hence it is advisable not to use such symbols to mean two different terms in one and the same drawing. If it becomes unavoidable, the symbols may be provided with suitable subscript.

Table 20.1 Recommended Abbreviations
(Clause 20.2)

Term	Abbreviation
Across flats	AF
Alteration	ALT
Approved	APPD
Approximate	APPROX
Arrangement	ARRGT
Assembly	ASSY
Auxiliary	AUX
Cast iron	CI

Table 20.1 (Continued)

Term	Abbreviation
Centre line on a view	⌀
Centre line in a note	
Centre of gravity	CG
Centres	CRS
Chamfered, chamfer (in a note)	CHAM
Checked	CHKD
Cheese head	CH HD
Constant	CONST
Continued	CONTD
Counterbore	CBORE
Countersunk	CSK
Countersunk head	CSK HD
Cylinder or cylindrical	CYL
Diameter (in a note)	DIA
Diameter (preceding a dimension)	φ
Dimension	DIM
Drawing	DRG
East	E
Equi-spaced or Equally spaced	EQUI SP
Etcetera	etc
External	EXT
Figure	FIG.
Full indicated movement	FIM
General	GEN
Head	HD
Hexagon head	HEX HD
Hexagon or Hexagonal	HEX
Horizontal	HORZ
Hydraulic	HYD
Indian Standard	IS
Inside diameter	ID
Inspection/ed	INSP
Insulation or insulated	INSUL
Internal	INT
Least material condition	LMC
Left hand	LH
Long	LG
Machine	MC
Material	MATL
Maximum	MAX
Maximum material condition	MMC
Mechanical	MECH
Minimum	MIN
Miscellaneous	MISC
Nominal	NOM
North	N
Not to scale	NTS
Number	NO.
Opposite	OPP
Outside diameter	OD
Pitch circle diameter	PCD
Quality	QLY
Quantity	QTY
Radius (in a note)	RAD
Radius (preceding a dimension)	R

Table 20.1 (Continued)

Term	Abbreviation
Reference	REF
Required	REQD
Right hand	RH
Round Head	RD HD
Screw (or screwed)	SCR
Serial number	SL NO.
Sheet (referring to drawing sheet)	SH
Sketch (prefix to a drawing No.)	SK
South	S
Specification	SPEC
Spherical	SPHERE
Spherical diameter (only preceding a dimension)	S ϕ
Spherical radius (only preceding a dimension)	SR
Spotface	SFACE
Square (in a note)	SQ

Table 20.1 (Continued)

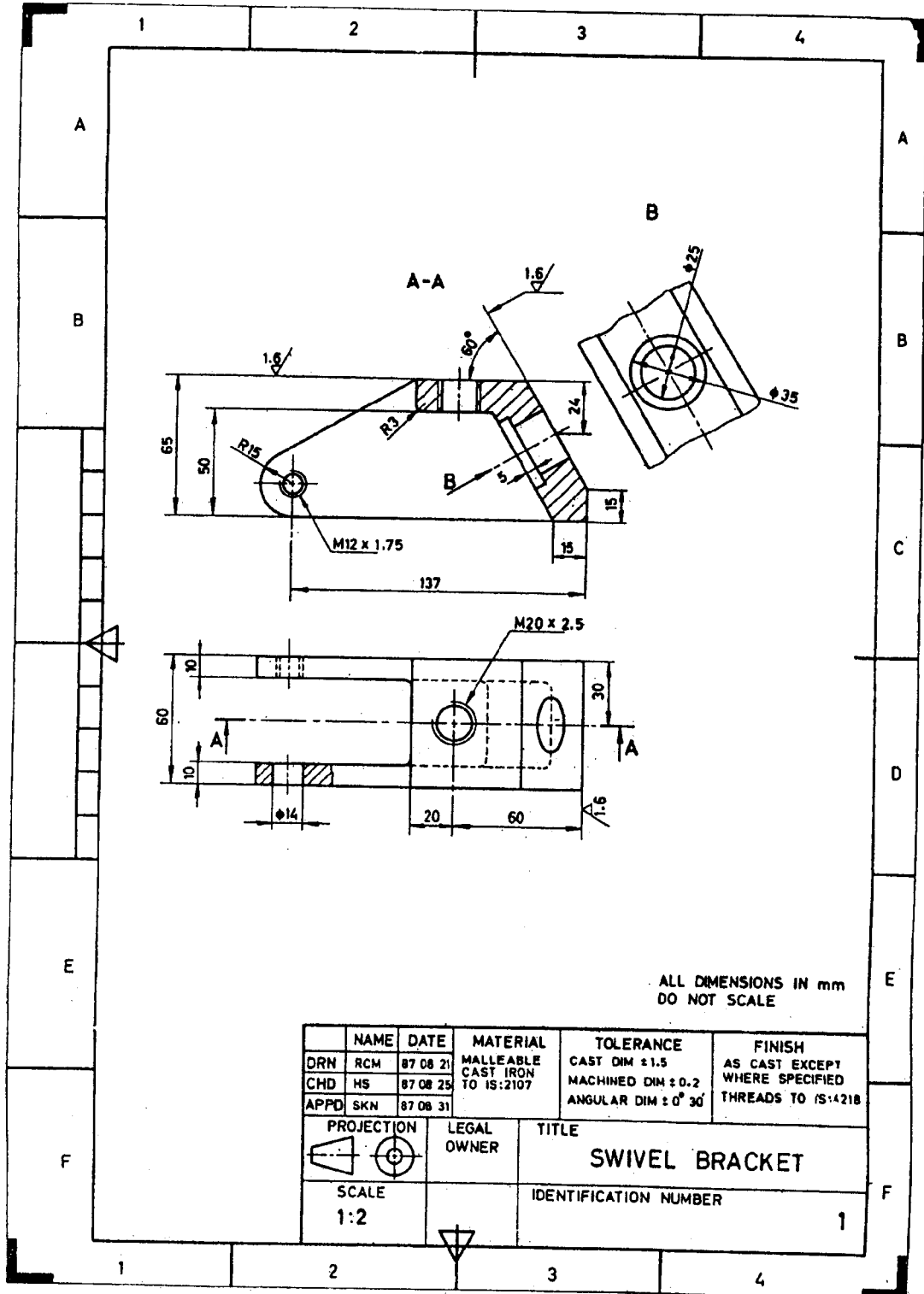
Term	Abbreviation
Square (preceding a dimension)	\square or \boxtimes
Standard	STD
Symmetrical (in a note)	SYM
Taper on diameter or, width	\rightarrow
Temperature (in a note)	TEMP
Thick	THK
Thread (in a note)	THD
Through (in a note)	THRU
Tolerance	Tol
Typical/Typically	TYP
Undercut	UCUT
Volume	VOL
Weight	WT
West	W
With reference to or with respect to	WRT

ANNEX A

(This Annex forms an integral part of this Special Publication)

TYPICAL EXAMPLES

EXAMPLE 1



ALL DIMENSIONS IN mm
DO NOT SCALE

NAME	DATE	MATERIAL	TOLERANCE	FINISH
DRN RCM	87 08 21	MALLEABLE CAST IRON TO IS:2107	CAST DIM ± 1.5	AS CAST EXCEPT WHERE SPECIFIED
CHD HS	87 08 25		MACHINED DIM ± 0.2	THREADS TO IS:4218
APPD SKN	87 08 31		ANGULAR DIM $\pm 0^{\circ} 30'$	
PROJECTION	LEGAL OWNER	TITLE		
		SWIVEL BRACKET		
SCALE		IDENTIFICATION NUMBER		
1:2		1		

ANNEX B

(This Annex forms an integral part of this Special Publication)

SYSTEMS OF LIMITS AND FITS

B-1 GENERAL

For the sake of simplicity, and in view of the particular importance of cylindrical parts with circular parts with circular section, only limits and fits are referred to explicitly. It should be clearly understood, however, that recommendations for this type of component apply equally well to other plain parts or components; in particular, the general term 'hole' or 'shaft' can be taken as referring to the space containing or contained by two parallel faces (or tangent planes) of any part, such as, the width of a slot, the thickness of the key, etc.

B-2 REFERENCE TEMPERATURE

The standard reference temperature is 20°C for industrial measurements and consequently, for dimensions defined by the system (*see* B-5).

B-3 TOLERANCES OF PARTS

Mainly due to the inevitable inaccuracy of manufacturing methods, a part cannot be made precisely to a given dimensions but, in order to meet its purpose, it is sufficient that it should be made so as to lie within two permissible limits of size, the difference of which is the tolerance.

B-3.1 For the sake of convenience, a basic size is ascribed to the part and each of the two limits is defined by its deviation from basic size. The magnitude and sign of the deviation are obtained by subtracting the basic size from the limit in question.

B-3.2 Figure B-1 which illustrates these definitions, is in practice replaced by a schematic diagram similar

to Fig. B-2 for the sake of simplicity. In this simplified schematic diagram, the axis of the part, which is not represented, always lies, by convention, below the diagram (in the example illustrated, the two deviations of the shaft are negative and those of the hole positive).

B-4 FITS

When two parts are to be assembled, the relation resulting from the difference between their sizes before assembly is called a fit.

B-4.1 Depending upon the respective positions of the tolerance zones of the hole or the shaft, the fit may be a clearance fit, a transition fit (that is the assembly may have either a clearance or an interference), or an interference fit.

B-4.2 Figure B-1 shows a clearance fit, and Fig. B-3 shows the schematic diagram of tolerance zone in various cases.

B-5 FIT SYSTEM

Two of the most commonly used methods of applying are the hole-basis system and the shaft-basis system which are shown in Fig. B-4.

B-6 SYMBOLS FOR TOLERANCES AND DEVIATIONS AND SYMBOLS FOR FITS

In order to satisfy the usual requirements both of individual parts and of fits, the system provides, for any given basic size, a whole range of tolerances together with a whole range of deviations defining the position of these tolerances with respect to the line of zero deviation, called the zero line.

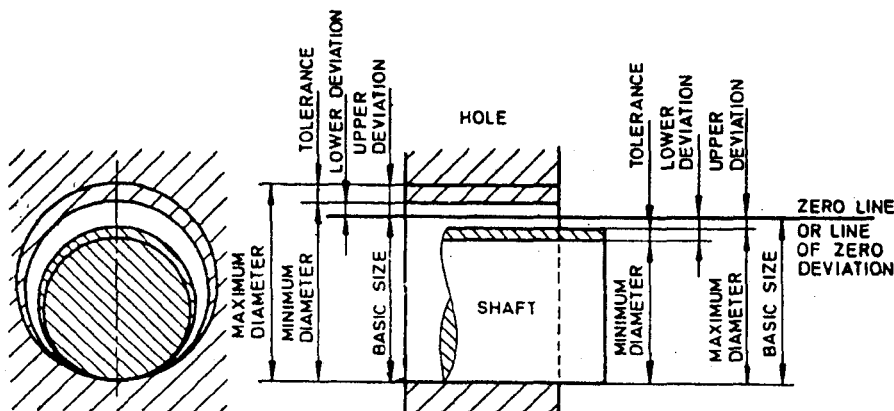


FIG. B-1 BASIC SIZE DEVIATIONS AND TOLERANCES

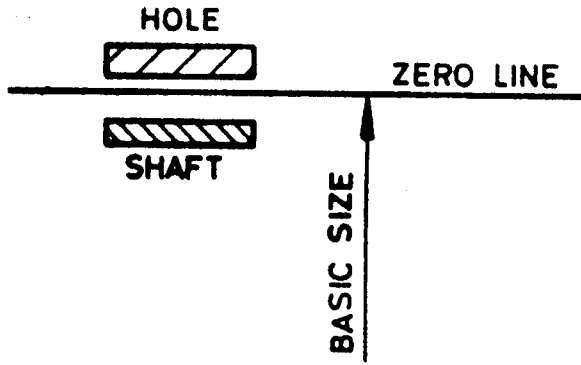


FIG. B-2 SIMPLIFIED SCHEMATIC DIAGRAM OF CLEARANCE FIT

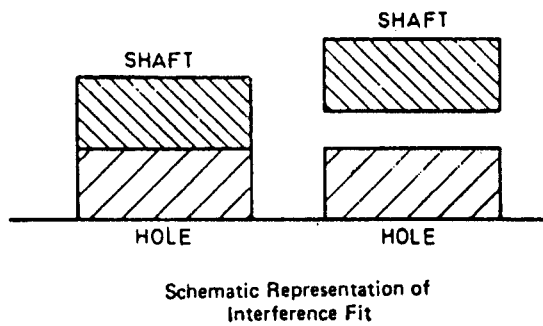
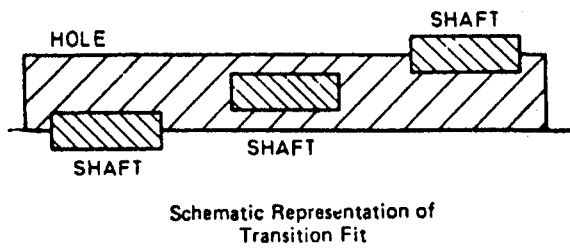
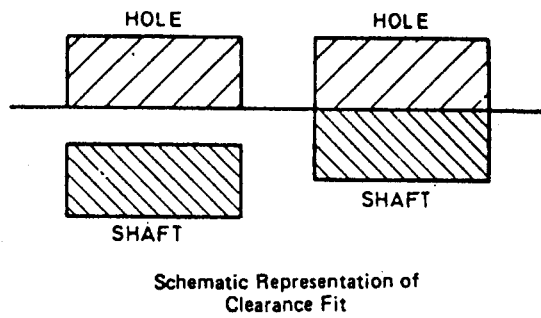


FIG. B-3 DIAGRAMATIC REPRESENTATION OF CLEARANCE FIT, TRANSITION FIT AND INTERFERENCE FIT

B-6.1 The tolerance, the value of which is function of the basic size, is designated by a number symbol, called the grade.

B-6.2 The position of the tolerance zone with respect to the zero line, which is a function of the basic size, is indicated by a letter symbol (in some cases, two letters), a capital letter for holes, a small letter for shafts (see Fig. B-5).

B-6.3 The toleranced size is thus defined by its basic value followed by a 'symbol' composed of the letter (in some cases, two letters) and a number.

Examples: 45 g7

B-6.4 A fit is indicated by the basic size common to both components, followed by symbol corresponding to each component, the hole being quoted first.

Examples: 45 H8/g7 (possibly 45 H8-g7 or 45 H8/g7).

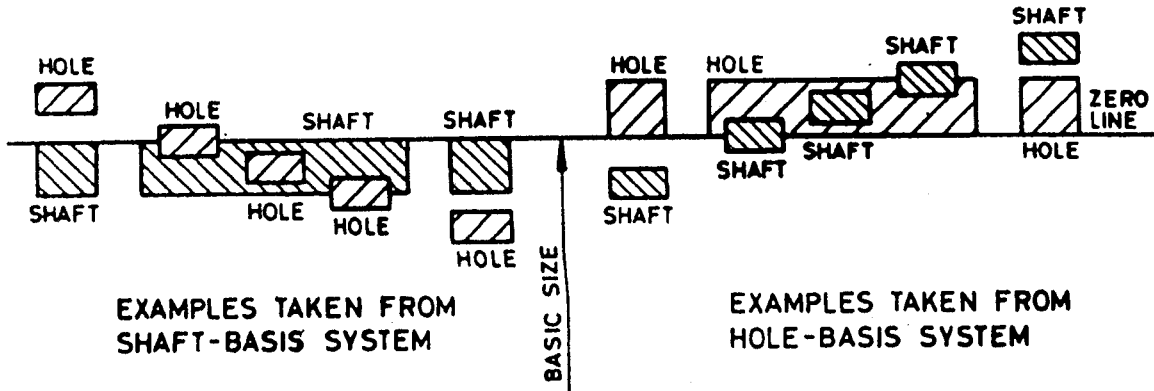


FIG. B-4 EXAMPLES ILLUSTRATING THE SHAFT-BASIS AND HOLE-BASIS SYSTEM

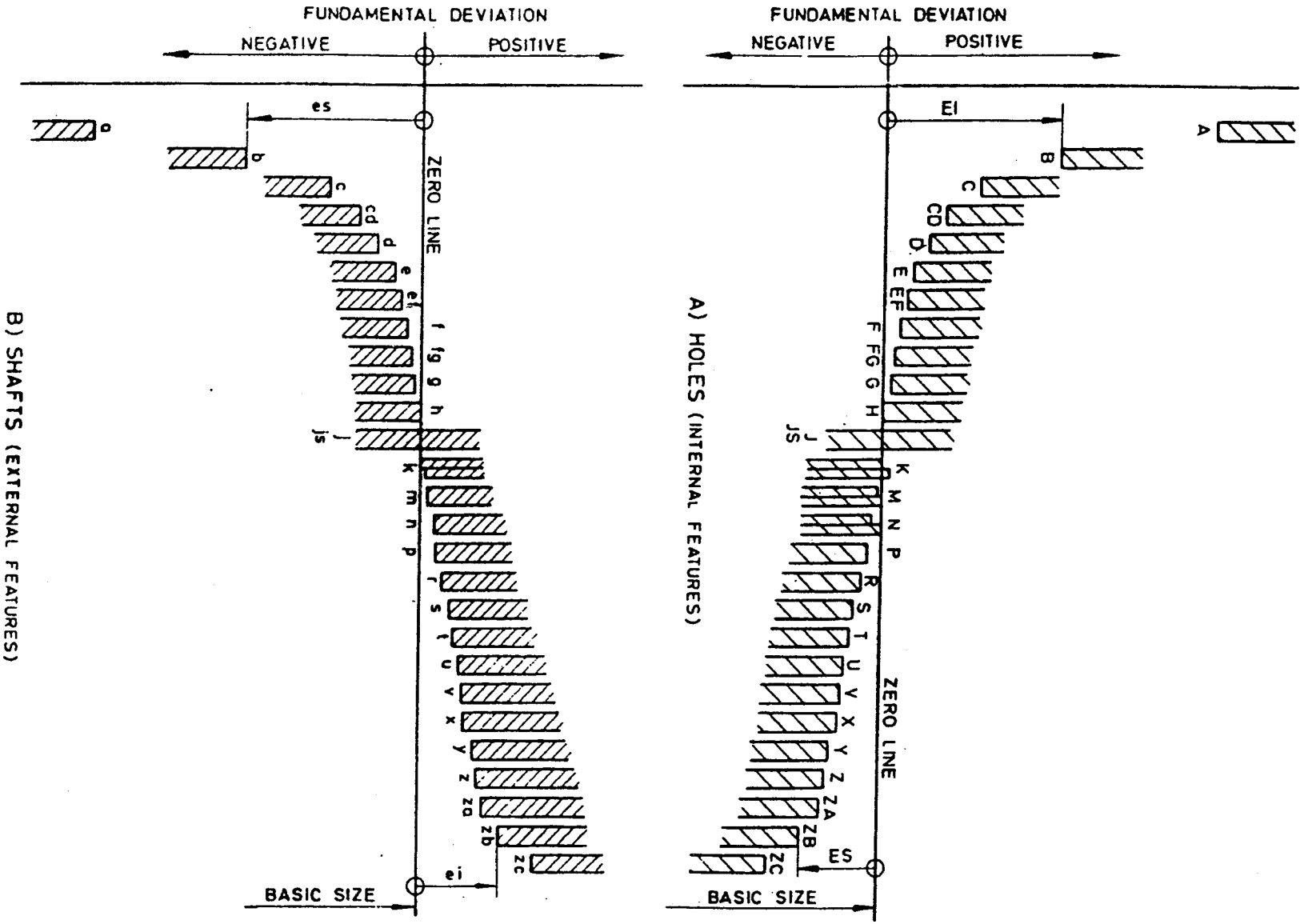


FIG. B-5 LETTER SYMBOLS FOR TOLERANCES

ANNEX C

(This Annex forms an integral part of this Special Publication)

GUIDE FOR SELECTION OF FITS

C-1 GENERAL

This Annex gives recommendations for the selection of fits in engineering problems concerned with the mating of a shaft and a hole. These recommendations are also applicable to non-cylindrical fits.

C-1.1 This Annex gives the representative usage of various classes and grades to fit. These examples are only of an illustrative character and they do not specify any design details.

C-2 SYSTEM OF FITS

C-2.1 The hole-basis system is the system of fits in which design size of the hole is the basic size and the allowance is applied to the shaft (*see* Fig. C-1). In the shaft-basis system the design size of the shaft is the basic size and the allowance is applied to the hole.

C-2.1.1 The application of either system depends on many conditions, such as, the nature of product, the manufacturing methods, the condition of the raw material, etc.

C-2.1.2 The hole-basis system is the extensively used system. This is because a hole is more difficult to produce than a shaft due to the fixed character of hole producing tools. The shaft basis system should only be

used where it will convey unquestionable economic advantages, that is, where it is necessary to be able to mount several parts with holes having different deviations on a single shaft of drawn steel bar without machining the latter.

C-2.1.3 The designers should decide on the adoption of either system to secure general inter-changeability. A shaft dimension to a certain class of fit with a hole in the hole-basis system differs from the shaft giving the same fit in the shaft-basis system.

C-3 CLASSIFICATION OF FITS

C-3.1 The system of fits may be broadly classified as clearance fit, transition fit and interference fit.

C-3.1.1 Clearance fit results in a positive clearance over the whole range of the tolerance. Shafts *a* to *g* produce a clearance fit with the basic hole *H*.

C-3.1.2 Transition fit may result in either a clearance fit or interference fit depending on the actual value of the individual tolerances of the mating components. Shafts *js* to *n* produce transition fit with the basic hole *H*.

C-3.1.3 Interference fit results in a positive interference over the whole range of tolerance. Shafts *p* to *u* produce interference fit with the basic hole *H*.

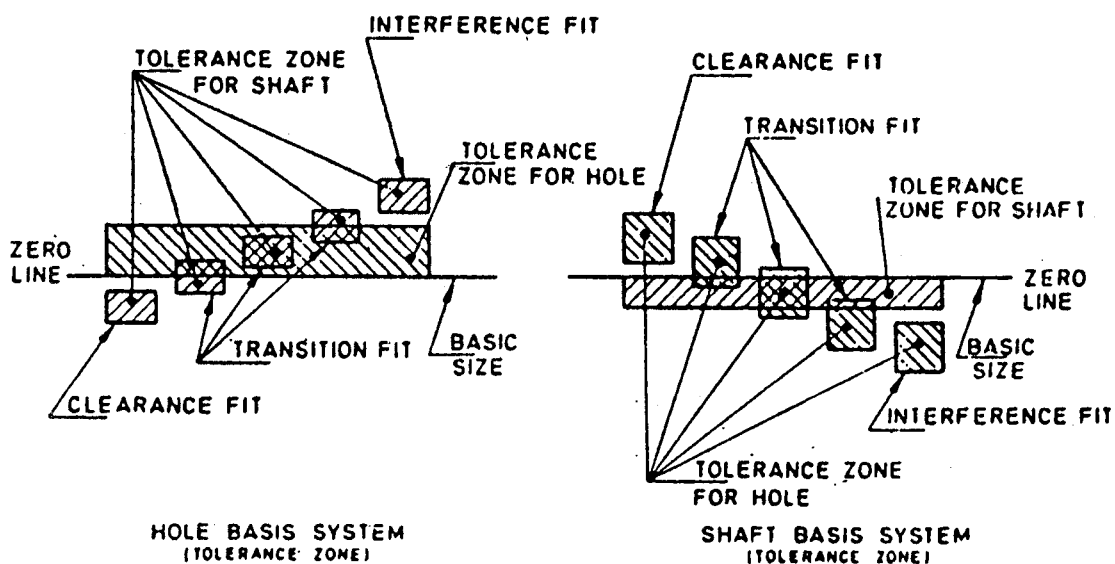


FIG. C-1 EXAMPLE ILLUSTRATING HOLE-BASIS AND SHAFT-BASIS SYSTEMS

C-3.1.4 Tolerances and deviations for both holes and shafts offer a wide range of fits of which many of the possible combinations may not be of practical use. Majority of common engineering requirements may be satisfied on the basis of a restricted selection of tolerance grades resulting in economy and ease of standardization, yet leading to universally applicable and recommended fits. The commonly used fits are given in Table C-4.

C-4 CHOICE OF FITS AND TOLERANCES

C-4.1 Fits

Fits may be selected on the hole-basis system or the shaft-basis system. The choice of fits considerably depends on the material of mating parts, workmanship, length of engagement, bearing load, speed, type of lubrication, temperature, humidity, surface finish, etc.

C-4.2 Tolerances

In order to obtain the most economic manufacture consistent with satisfactory quality, it is recommended that as wide a tolerance shall be provided as is possible. In the allocation of tolerances to the hole and the shaft members of a fit, it is generally advisable to give a larger tolerance to the hole than to the shaft due to the

fact that hole is more difficult to produce than a shaft. The exception is in the case of very large sizes where the effects of temperature play a large role.

C-4.2.1 The tolerances chosen shall be the largest compatible with the conditions of use the hole being the more difficult member to machine, may often be allocated a tolerance one grade coarser than that of the shaft (for example, H8-f7).

C-5 RECOMMENDATIONS

C-5.1 Recommendations for selection of tolerance zones for general purposes are given in Table C-1.

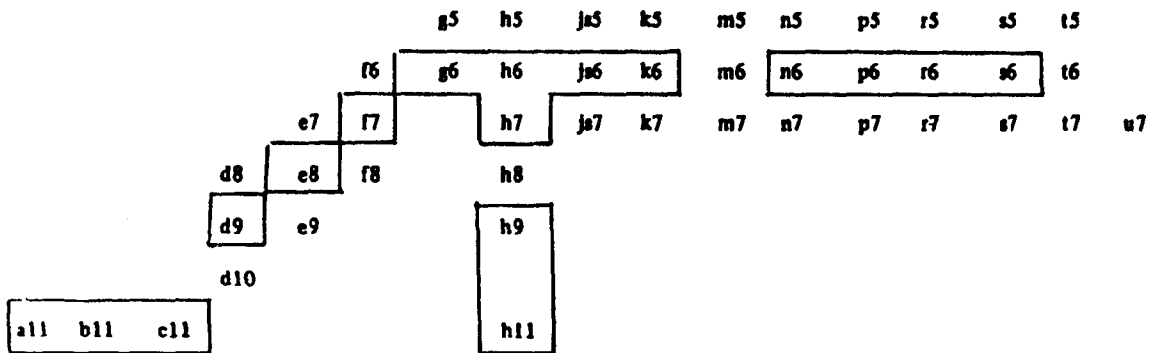
Wherever possible the tolerance zones shall be chosen from the corresponding symbols for shafts and holes as indicated in Table C-1. The first choice shall preferably be made from the symbols enclosed in the frames.

C-5.2 Limits for the tolerance zones enclosed in the frames in Table C-1 are given in Table C-2.

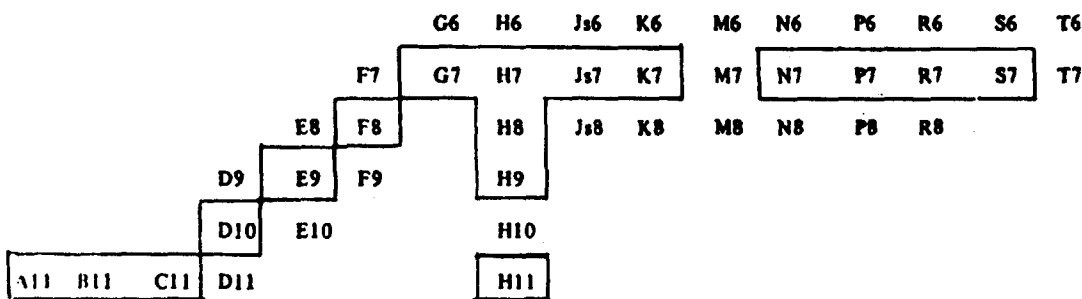
C-5.3 Dimensions for the fits chosen from the tolerance zones enclosed in the frames in Table C-1 are given in Table C-3.

Table C-1 Selection of Tolerance Zones
(Clause C-5.1)

For Shafts



For Holes



NOTE — Deviation js and Js may be replaced by the corresponding deviations j and J.

TABLE C-2/TOLERANCE ZONES AND LIMITS - DIMENSIONS IN μm

Nominal Size Range mm	From up to	as	rs	ps	as	hs	js	hs	h7	h8	h11	gs	17	es	ds	cl1	b11	a11	S7	R7	P7	N7	K7	Js7	H7	H8	H9	H11	G7	F8	E8	D10	C11	B11	A11			
		1 3	+20 +14	+18 +10	+12 +6	+10 +4	+8 0	+3 -3	0 -6	0 -10	0 -25	0 -60	-2 -6	-6 -16	-14 -26	-20 -45	-90 -120	-140 -200	-270 -330	-14 -24	-10 -20	-6 -16	-4 -10	0 -5	+5 -5	+10 0	+14 0	+25 0	+60 0	+12 +2	+20 +8	+30 +14	+60 +20	+120 +60	+200 +140	+330 +270		
Over up to	3 6	+27 +19	+23 +15	+20 +12	+16 +8	+9 +1	+4 -4	0 -8	0 -12	0 -30	0 -75	-4 -12	-10 -22	-20 -38	-30 -60	-70 -145	-140 -215	-270 -345	-15 -27	-11 -23	-8 -20	-4 -16	+3 -9	+6 -6	+12 0	+18 0	+30 0	+75 0	+18 +4	+28 +10	+50 +20	+78 +30	+145 +70	+215 +140	+345 +270			
Over up to	6 10	+32 +23	+28 +19	+24 +15	+18 +10	+10 +1	+4.5 -4.5	0 -9	0 -15	0 -36	0 -90	-5 -14	-13 -28	-25 -47	-40 -76	-80 -170	-150 -240	-280 -370	-17 -32	-13 -28	-9 -24	-4 -19	+5 -10	+7.5 -7.5	+15 0	+22 0	+36 0	+90 0	+20 +5	+35 +13	+61 +25	+96 +40	+170 +80	+240 +150	+370 +280			
Over up to	10 14	+39	+34	+29	+23	+12	+5.5	0	0	0	0	-6	-16	-32	-50	-95	-150	-290	-21	-16	-11	-5	+6	+9	+18	+27	+43	+110	+24	+43	+75	+120	+205	+280	+400			
Over up to	14 18	+28	+23	+18	+12	+1	-5.5	-11	-18	-43	-110	-17	-34	-58	-83	-205	-260	-400	-39	-34	-29	-23	-12	-9	0	0	0	0	+6	+16	+32	+59	+85	+150	+230			
Over up to	18 24	+46	+41	+35	+28	+15	+8.5	0	0	0	0	-7	-20	-40	-65	-110	-160	-300	-27	-20	-14	-7	+9	+10.5	+21	+33	+52	+130	+28	+53	+82	+148	+240	+290	+430			
Over up to	24 30	+35	+28	+22	+15	+2	-6.5	-13	-21	-52	-130	-20	-41	-73	-117	-240	-290	-430	-46	-41	-35	-28	-15	-10.5	0	0	0	0	+7	+20	+40	+65	+110	+160	+230			
Over up to	30 40	+59	+50	+42	+33	+18	+8	0	0	0	0	-9	-25	-50	-80	-120	-170	-310	-34	-25	-17	-8	+7	+12.5	+25	+36	+62	+160	+34	+64	+112	+190	+280	+370	+470			
Over up to	40 50	+43	+34	+26	+17	+2	-8	-16	-25	-62	-160	-25	-50	-89	-142	-130	-180	-320	-50	-50	-42	-33	-18	-12.5	0	0	0	0	+9	+25	+50	+80	+130	+180	+240	+320		
Over up to	50 65	+72 +53	+60 +41	+51	+39	+21	+9.5	0	0	0	0	-10	-30	-60	-100	-140	-190	-340	-42	-30	-21	-9	+9	+15	+30	+48	+74	+180	+40	+70	+134	+220	+320	+430	+530			
Over up to	65 80	+78 +59	+62 +43	+52	+40	+2	-9.5	-19	-30	-74	-190	-29	-60	-106	-174	-150	-200	-360	-48	-32	-21	-30	-21	-18	0	0	0	0	+10	+30	+60	+100	+160	+230	+330			
Over up to	80 100	+83 +71	+73 +51	+59	+45	+25	+11	0	0	0	0	-12	-36	-72	-120	-170	-220	-380	-58	-38	-24	-10	+10	+17.5	+35	+54	+87	+220	+47	+96	+180	+280	+390	+500	+630			
Over up to	100 120	+101 +79	+78 +54	+57	+43	+3	-11	-22	-35	-87	-220	-34	-71	-126	-207	-180	-240	-410	-68	-41	-59	-45	-25	-17.5	0	0	0	0	+12	+36	+72	+120	+200	+280	+380			
Over up to	120 140	+117 +92	+88 +63													-200	-260	-460	-77	-48														+450	+510	+710		
Over up to	140 160	+125 +100	+90 +65	+68 +43	+52 +27	+3	+12.5 -12.5	0 -25	0 -40	0 -100	0 -250	-14 -39	-43 -83	-85 -148	-145 -245	-210	-280	-520	-85	-50	-26	-12	+12	+20	+40	+53	+100	+250	+54	+106	+185	+305	+460	+530	+770			
Over up to	160 180	+133 +108	+93 +68													-230	-310	-560	-93	-53															+480	+560	+830	
Over up to	180 200	+151 +122	+106 +77													-240	-340	-600	-105	-60																+530	+630	+950
Over up to	200 225	+159 +130	+109 +80	+79 +50	+60 +31	+33 +4	+14.5 -14.5	0 -29	0 -46	0 -115	0 -290	-15 -44	-50 -96	-100 -172	-170 -285	-260	-380	-740	-113	-63	-33	-14	+13	+23	+46	+72	+115	+290	+61	+122	+215	+355	+550	+670	+1030			
Over up to	225 250	+169 +140	+113 +84													-280	-420	-820	-123	-67	-79	-60	-33	-23	0	0	0	0	+15	+50	+100	+170				+570	+710	+1110
Over up to	250 280	+190 +158	+126 +94	+88	+66	+36	+16	0	0	0	0	-17	-56	-110	-190	-300	-480	-920	-138	-74	-36	-14	+16	+25	+52	+81	+130	+320	+69	+137	+240	+400	+620	+800	+1240			
Over up to	280 315	+202 +170	+130 +98	+56	+34	+4	-16	-32	-52	-130	-320	-49	-108	-191	-320	-330	-540	-1050	-150	-78	-88	-66	-36	-26	0	0	0	0	+17	+53	+110	+190	+650	+860	+1370			
Over up to	315 355	+226 +190	+144 +108	+98	+73	+40	+18	0	0	0	0	-18	-62	-125	-210	-360	-600	-1200	-169	-87	-41	-18	+17	+28.5	+57	+89	+140	+360	+75	+151	+265	+440	+720	+960	+1560			
Over up to	355 400	+244 +208	+150 +114	+62	+37	+4	-18	-35	-57	-140	-360	-54	-119	-214	-350	-400	-680	-1350	-187	-93	-98	-73	-40	-28.5	0	0	0	0	+18	+68	+125	+210	+760	+1040	+1710			
Over up to	400 450	+272 +232	+166 +126	+108	+80	+45	+20	0	0	0	0	-20	-68	-135	-230	-440	-780	-1500	-209	-103	-68	-45	+17	+31.5	+63	+97	+155	+400	+83	+166	+290	+480	+840	+1160	+1900			
Over up to	450 500	+292 +252	+172 +132	+68	+40	+5	-20	-40	-63	-155	-400	-60	-131	-232	-355	-480	-840	-1650	-229	-109	-108	-60	-45	-31.5	0	0	0	0	+20	+68	+135	+230	+890	+1240	+2050			

Table C-4 Commonly Used Fits
(Clause C-3.1.4)

I For Holes

Type of Fit	Class of Shaft	With Holes					Remarks
		H6*	H7	H8	H9	H11	
Clearance	a	—	—			a11	Large clearance fit and widely used
	b					b11	
	c	—	—			c11	Slack running fit
	d	—	d8*	d8*, d9, d10	d8*, d9, d10	d9	Loose running fit
	e	e7*	e8	e8, e9*			Easy running fit
	f	f6*	f7	f7, f8*			Normal running fit
	g	g5*	g6	—			Close running fit or sliding fit, also spigot and location fit
	h	h5*	h6	h7, h8*, h9		h11	Precision sliding fit. Also fine spigot and location fit.
Transition	js	js5*	js6	js7*			Push fit for very accurate location with easy assembly and disassembly
	k	k5*	k6	k7*			Light keying fit (true transition) for keyed shafts, non-running locked pins, etc.
	m	m5*	m6*	m7*			Medium keying fit
	n	n5*	n6	n7*			Heavy keying fit (for tight assembly mating surfaces)
Interference	p	p5*	p6	p7*			Light press fit with easy dismantling for non-ferrous parts. Standard press fit with easy dismantling for ferrous and non-ferrous parts assembly
	r	r5*	r6	r7*			Medium drive fit with easy dismantling for ferrous parts assembly Light drive fit with easy dismantling for non-ferrous parts assembly
	s	s5*	s6	s7*			Heavy drive fit for ferrous parts permanent or semi-permanent assembly standard press fit for non-ferrous parts
	t	t5*	t6*	t7*			Force fit on ferrous parts for permanent assembly
	u			u7*			Heavy force fit or shrink fit

* Second preference fits.

Table C-4 — (Concluded)

II For Shafts

Type of Fit	Class of Holes	With Shafts						Remarks
		h5*	h6	h7	h8*	h9	h11	
Clearance	A						A11	Large clearance fit widely used
	B						B11	
	C						C11	Slack running fit
	D		D9*		D10	D10	D11*	Loose running fit
	E		E8*		E8*	E9		Easy running fit
	F		F7*		F8	F8*		Normal running fit
	G	G6*	G7					Close running fit or sliding fit, also spigot and location fit
	H	H6*	H7	H8	H8	H8, H9	H11	Precision sliding fit. Also fine spigot and location fit.
Transition	Js	Js6*	Js7	Js8*				Push fit for very accurate location with easy assembly and disassembly
	K	K6*	K7	K8*				Light keying fit (true transition) for keyed shafts, non-running locked pins, etc.
	M	M6*	M7*	M8*				Medium keying fit
	N	N6*	N7	N8*				Heavy keying fit (for tight assembly of mating surfaces)
Interference	P	P6*	P7					Light press fit with easy dismantling for non-ferrous parts. Standard press fit with easy dismantling for ferrous and non-ferrous parts assembly
	R	R6*	R7					Medium drive fit with easy dismantling for ferrous parts assembly Light drive fit with easy dismantling for non-ferrous parts assembly
	S	S6*	S7					Heavy drive fit for ferrous parts permanent or semi-permanent assembly standard press fit for non-ferrous parts
	T	T6*	T7					Force fit on ferrous parts for permanent assembly

* Second preference fits.

ANNEX D

(This Annex forms an integral part of this Special Publication)

GENERAL TOLERANCES FOR LINEAR AND ANGULAR DIMENSIONS

D-1 GENERAL

Specifies the permissible machining variations in linear and angular dimensions without tolerance indications.

D-1.1 This Annex is applicable for all machining processes with chips like turning, milling, etc and without chips like drawing, printing, embossing, pipe bending, etc, and is not applicable for production methods like casting, forging, processing, welding, flame cutting, etc.

D-2 DEVIATIONS

D-2.1 Linear Dimensions

Shall be as given in Table D-1.

D-2.2 Radii and Chamfer

Shall be as given in Table D-2.

D-2.3 Angular Dimensions

Shall be as given in Table D-3.

D-3 INDICATION IN DRAWINGS

In the space provided for the purpose of drawings or otherwise, two methods of indications are suggested:

- a) Class of deviation required shall be indicated, for example, Medium IS 2102, Coarse IS 2102, etc.
- b) The values of the permissible variations to be shown in general note for dimensions without tolerance indications.

Table D-1 Deviations for Linear Dimensions

(Clause D-2.1)

All dimensions in millimetres.

Class of Deviation	Range of Nominal Dimensions												
	Above	0.5	3	6	30	120	315	1 000	2 000	4 000	8 000	12 000	16 000
	Up to and Including	3	6	30	120	315	1 000	2 000	4 000	8 000	12 000	16 000	20 000
Fine	± 0.05	± 0.05	± 0.1	± 0.15	± 0.2	± 0.3	± 0.5	± 0.8	—	—	—	—	—
Medium	± 0.1	± 0.1	± 0.2	± 0.3	± 0.5	± 0.8	± 1.2	± 2	± 3	± 4	± 5	± 6	—
Coarse	—	± 0.2	± 0.5	± 0.8	± 1.2	± 2	± 3	± 4	± 5	± 6	± 7	± 8	—
Extra coarse	—	± 0.5	± 1	± 1.5	± 2	± 3	± 4	± 6	± 8	± 10	± 12	± 12	—

Table D-2 Deviations for Radii and Chamfers

(Clause D-2.2)

All dimensions in millimetres.

Class of Deviation	Range of Nominal Dimensions					
	Above	0.5	3	6	30	120
	Up to and including	3	6	30	120	315
Fine and medium	± 0.2	± 0.5	± 1	± 2	± 4	—
Coarse and extra coarse	± 0.2	± 1	± 2	± 4	± 8	—

Table D-3 Deviations for Angular Dimensions
(Clause D-2.3)

All dimensions in millimetres.

Class of Deviation	Permissible Variations on Length of Shorter Side of Angle							
	Upto 10		Over 10 to 50		Over 50 to 120		Over 120	
	Degree	mm per 100 mm	Degree	mm per 100 mm	Degree	mm per 100 mm	Degree	mm per 100 mm
Fine and Medium	$\pm 1^\circ$	± 1.8	$\pm 30'$	± 0.9	$\pm 20'$	± 0.6	± 10	± 0.3
Coarse	$\pm 1^\circ 30'$	± 2.6	$\pm 50'$	± 1.5	$\pm 25'$	± 0.7	$\pm 15'$	± 0.4
Extra coarse	$\pm 3^\circ$	± 5.1	$\pm 2^\circ$	± 3.5	$\pm 1^\circ$	± 1.8	$\pm 30'$	± 0.9

ANNEX E

LIST OF REFERRED AND OTHER RELEVANT INDIAN STANDARDS AND INTERNATIONAL STANDARDS

<i>Standard No.</i>	<i>Title</i>
IS 813 : 1986	Scheme of symbols for welding
IS 919 (Part 1) : 1993/ ISO 286-1 : 1988	ISO systems of limits and fits: Part 1 Bases of tolerances, deviations and fits (<i>second revision</i>)
IS 919 (Part 2) : 1993/ ISO 286-2 : 1988	ISO systems of limits and fits: Part 2 Tables of standard tolerance grades and limit deviations for holes and shafts (<i>first revision</i>)
IS 1076 (Part 1) : 1985/ ISO 3 : 1973	Preferred numbers: Part 1 Series of preferred numbers (<i>second revision</i>)
IS 1076 (Part 2) : 1985/ ISO 17 : 1973	Preferred numbers: Part 2 Guide to the use of preferred numbers and series of preferred numbers (<i>second revision</i>)
IS 1076 (Part 3) : 1985/ ISO 497 : 1973	Preferred numbers: Part 3 Guide to the choice of series of preferred number and of series containing more rounded values of preferred numbers (<i>second revision</i>)
IS 2102 (Part 1) : 1993/ ISO 2768-1 : 1989	General tolerances: Part 1 Tolerances for linear and angular dimensions without individual tolerance indications (<i>third revision</i>)
IS 2102 (Part 2) : 1993/ ISO 2768-2 : 1989	General tolerances: Part 2 Geometrical tolerances for features without individual tolerance indications
IS 3073 : 1967	Assessment of surface roughness
IS 3403 : 1981	Dimensions for knurls
IS 4218 (Part 1) : 2001/ ISO 68-1 : 1998	ISO general purpose metric screw threads: Part 1 Basic profiles (<i>second revision</i>)
IS 4218 (Part 2) : 2001/ ISO 261 : 1998	ISO general purpose metric screw threads: Part 2 Diameter pitch combination (<i>second revision</i>)
IS 4218 (Part 3) : 1999/ ISO 724 : 1993	ISO general purpose metric screw threads: Part 3 Basic dimensions for design profile (<i>second revision</i>)
IS 4218 (Part 4) : 2001/ ISO 262 : 1998	ISO general purpose metric screw threads: Part 4 Selected sizes for screw, bolts and nuts (<i>second revision</i>)
IS 7283 : 1992	Hot rolled bars for production of bright bars and machined parts for engineering applications (<i>first revision</i>)
IS 8000 (Part 1) : 1985/ ISO 1101 : 1983	Geometrical tolerancing on technical drawings: Part 1 Tolerances of form, orientation, location and run-out and appropriate geometrical definitions (<i>first revision</i>)
IS 8000 (Part 2) : 1976/ ISO 2692 : 1988	Geometrical tolerancing on technical drawings: Part 2 Maximum material principles (<i>first revision</i>)
IS 8000 (Part 3) : 1985/ ISO 1660 : 1987	Geometrical tolerancing on technical drawings: Part 3 Dimensioning and tolerancing of profiles
IS 8000 (Part 4) : 1976	Geometrical tolerancing on technical drawings: Part 4 Practical examples of indications on drawings
IS 8930 (Part 1) : 1995/ ISO 10209-1 : 1992	Technical product documentation — Vocabulary: Part 1 Terms relating to technical drawings (<i>first revision</i>)

<i>Standard No.</i>	<i>Title</i>
IS 8930 (Part 2) : 2001/ ISO 10209-2 : 1993	Technical product documentation: Part 2 Terms relating to projection methods
IS 8976 : 1978	Guide for the preparation and arrangement of sets of drawings and parts lists
IS/ISO 9178-1 : 1988	Templates for lettering and symbols: Part 1 General principles and identification markings
IS 9609 (Part 0) : 2001/ ISO 3098-0 : 1997	Technical product documentation — Lettering: Part 0 General requirements
IS 9609 (Part 1) : 1983/ ISO 3098-1 : 1974	Lettering on technical drawings: Part 1 English lettering (<i>first revision</i>)
IS 9609 (Part 2) : 1985/ ISO 3098-2 : 1984	Lettering on technical drawings: Part 2 Greek characters
IS 9609 (Part 3) : 1991/ ISO 3098-3 : 1987	Technical drawings — Lettering: Part 3 Diacritical and particular marks for the Latin alphabet
IS 9609 (Part 4) : 1991/ ISO 3098-4 : 1984	Technical drawings — Lettering: Part 4 Cyrillic characters
IS 9609 (Part 5) : 1998	Lettering on technical drawings: Part 5 Amplified devnagri letters
IS 9609 (Part 6) : 2001/ ISO 3098-5 : 1997	Technical product documentation — Lettering: Part 6 CAD lettering of the Latin alphabet, numerals and marks
IS 10164 : 1985/ ISO 6428 : 1982	Requirements to execute technical drawings for microcopying (<i>first revision</i>)
IS 10711 : 1983/ ISO 5457 : 1980	Sizes of drawing sheets
IS 10712 : 1983/ ISO 6433 : 1981	Presentation of item references on technical drawings
IS 10713 : 1983/ ISO 5455 : 1979	Scales for use on technical drawings
IS 10714 : 1983/ ISO 128 : 1982	General principles of presentation on technical drawings
IS 10714 (Part 20) : 2001 ISO 128-20 : 1996	Technical drawings — General principles of presentation: Part 20 Basic conventions for lines
IS 10714 (Part 21) : 2001 ISO 128-21 : 1997	Technical drawings — General principles of presentation: Part 21 Preparation of lines by CAD systems
IS 10715 (Part 1) : 1999/ ISO 6410-1 : 1993	Technical drawings — Screw threads and threaded parts: Part 1 General conventions (<i>first revision</i>)
IS 10715 (Part 3) : 1999/ ISO 6410-3 : 1993	Technical drawings — Screw threads and threaded parts: Part 3 Simplified representation
IS 10716 (Part 1) : 1999/ ISO 2162-1 : 1973	Technical product documentation — Springs: Part 1 Simplified representation (<i>first revision</i>)
IS 10717 : 1983/ ISO 2203 : 1973	Conventional representation of gears on technical drawings
IS 10718 : 1993/ ISO 3040 : 1990	Technical drawings — Dimensions and tolerancing of cones (<i>first revision</i>)
IS 10719 : 1983/ ISO 1302 : 1978	Method of indicating surface texture on technical drawings
IS 10720 : 1999/ ISO 5261 : 1995	Technical drawings — Simplified representation of bars and profile sections (<i>first revision</i>)

<i>Standard No.</i>	<i>Title</i>
IS 10721 : 1983/ ISO 5459 : 1981	Datum and datum systems for geometrical tolerancing on technical drawings
IS 10990 (Part 1) : 1991/ ISO 6412-1 : 1989	Technical drawings — Simplified representation of pipelines: Part 1 General rules and orthogonal representation (<i>first revision</i>)
IS 10990 (Part 2) : 1992/ ISO 6412-2 : 1989	Technical drawings — Simplified representation of pipelines: Part 2 Isometric projections (<i>first revision</i>)
IS 11065 (Part 1) : 1984	Drawing practice for axonometric projection: Part 1 Isometric projection
IS 11065 (Part 2) : 1985	Drawing practice for axonometric projection: Part 2 Dimetric projection
IS 11663 : 1986	Conventional representation of common features and materials on technical drawings
IS 11664 : 1986	Folding of drawing prints
IS 11665 : 1985/ ISO 7200 : 1984	Technical drawings — Title blocks
IS 11666 : 1985/ ISO 7573 : 1983	Technical drawings — Item lists
IS 11667 : 1991/ ISO 406 : 1987	Technical drawings — Linear and angular tolerancing — Indication on drawings (<i>first revision</i>)
IS 11669 : 1986/ ISO 129 : 1985	General principles of dimensioning on technical drawings
IS 11670 : 1993	Technical drawings — Abbreviations and symbols for use in technical drawings (<i>first revision</i>)
IS 14440 : 1997	Drawing instruments — Tubular tips for hand held technical pens using India ink on tracing paper — Specification
IS 15021 (Part 1) : 2001/ ISO 5456-1 : 1996	Technical drawings — Projection methods: Part 1 Synopsis
IS 15021 (Part 2) : 2001/ ISO 5456-2 : 1996	Technical drawings — Projection methods: Part 2 Orthographic representations
IS 15021 (Part 3) : 2001/ ISO 5456-3 : 1996	Technical drawings — Projection methods: Part 3 Axonometric representations
IS 15021 (Part 4) : 2001/ ISO 5456-4 : 1996	Technical drawings — Projection methods: Part 4 Central projection
IS 15023 (Part 1) : 2001/ ISO 5845-1 : 1995	Technical drawings — Simplified representation of the assembly of parts with fasteners: Part 1 General principles
IEC 61082-1 : (1991)	Preparation of documents used in electrotechnology: Part 1 General requirements
ISO 128-22 : 1999	Technical drawings — General principles of presentation — Part 22 : Basic conventions and applications for leader lines and reference lines
ISO 128-23 : 1999	Technical drawings — General principles of presentation — Part 23 : Lines on construction drawings
ISO 128-24 : 1999	Technical drawings — General principles of presentation — Part 24 : Lines on mechanical engineering drawings
ISO 128-25 : 1999	Technical drawings — General principles of presentation — Part 25 : Lines on shipbuilding drawings
ISO 216 : 1975	Writing paper and certain classes of printed matter — Trimmed sizes — A and B series
ISO 544 : 1989	Filler materials for manual welding — Size requirements
ISO 657-1 : 1989	Hot-rolled steel sections — Part 1 : Equal-leg angles — Dimensions

<i>Standard No.</i>	<i>Title</i>
ISO 1119 : 1998	Geometrical product specifications (GPS) — Series of conical tapers and taper angles
ISO 1219-1 : 1991	Fluid power systems and components — Graphic symbols and circuit diagrams — Part 1 : Graphic symbols
ISO 1219-2 : 1995	Fluid power systems and components — Graphic symbols and circuit diagrams — Part 2 : Circuit diagrams
ISO/DIS 1302 : 1999	Geometrical product specification (GPS) — Indication of surface texture in technical product documentation
ISO/IEC 2382-4 : 1999	Information technology — Vocabulary — Part 4 : Organization of data
ISO 2553 : 1992	Welded, brazed and soldered joints — Symbolic representation on drawings
ISO 2560 : 1973	Covered electrodes for manual arc welding of mild steel and low alloy steel — Code of symbols for identification
ISO 3461-1 : 1988	General principles for the creation of graphical symbols — Part 1 : Graphical symbols for use on equipment
ISO 3511-3 : 1984	Process measurement control functions and instrumentation — Symbolic representation — Part 3 : Detailed symbols for instrument interconnection diagrams
ISO 3545-1 : 1989	Steel tubes and fittings — Symbols for use in specifications — Part 1 : Tubes and tubular accessories with circular cross-section
ISO 3545-2 : 1989	Steel tubes and fittings — Symbols for use in specifications — Part 2 : Square and rectangular hollow sections
ISO 3545-3 : 1989	Steel tubes and fittings — Symbols for use in specifications — Part 3 : Tubular fittings with circular cross-section
ISO 3581 : 1976	Covered electrodes for manual arc welding of stainless and other similar high alloy steels — Code of symbols for identification
ISO 3753 : 1977	Vacuum technology — Graphical symbols
ISO 4063 : 1998	Welding and allied processes — Nomenclature of processes and reference numbers
ISO 4067-1 : 1984	Technical drawings — Installation — Part 1 : Graphical symbols for plumbing, heating, ventilation and ducting
ISO 4067-2 : 1980	Building and civil engineering drawings — Installation — Part 2 : Simplified representation of sanitary appliances
ISO 4067-6 : 1985	Technical drawings — Installation — Part 6 : Graphical symbols for supply water and drainage systems in the ground
ISO 5817 : 1992	Arc-welded joints in steel — Guidance on quality levels for imperfections
ISO 5864 : 1993	ISO inch screw threads — Allowances and tolerances
ISO 6947 : 1990	Welds — Working positions — Definitions of angles of slope and rotation
ISO 9175-1 : 1988	Tubular tips for hand-held technical pens using India ink on tracing paper — Part 1 : Definitions, dimensions, designation and marking
ISO 9175-2 : 1988	Tubular tips for hand-held technical pens using India ink on tracing paper — Part 2 : Performance, test parameters and test conditions
ISO 10042 : 1992	Arc-welded joints in aluminium and its weldable alloys — Guidance on quality levels for imperfections
DIN 199 (Part 2) : 1977	Terms in drawings and parts lists — Parts lists

ALPHABETICAL INDEX

A

Abbreviations, Section 20
 Additional dimension, **12.2.5** (a)
 Adjacent parts, **10.3.1**
 Altitude, indication of, **12.6.2.2**
 Angles, **12.5.1**
 Angle section, Table 17.1
 Angular dimension, tolerance of, Annex D
 Angular dimensional values, **12.3.4.1**
 Angular spacing, dimensions of, **12.5.2.2**
 Angularity, Table 19.1
 Arc end, **12.3.3.5**
 Arcs, **12.5.1**
 Arrangement of dimensions, **12.4**
 Arrangement of successive section, **10.2.9**
 Arrow heads, **12.3.3.1** (a)
 Assembly drawing (gear parts), **11D.3**
 Assembled threaded parts, **11A.2.3**
 Assembly drawings, planning of, Section 3
 Auxiliary dimension, **12.2.1.1** (a)

B

Basic size, **13.3.1** (a)
 Bolts, Tables 16.1 and 16.3
 Border, **1.6**
 Bulb angle section, Table 17.2
 Bulb flat, Table 17.2

C

Central line, **12.3.2.7**
 Centring mark, **1.7**
 Chain dimensioning, **12.4.1**
 Chain wheels, **11D.3.6**
 Chamfers, **12.5.4.1, D-2.2**
 Channel section, Table 17.2
 Choice of tolerance, C-4
 Choice of views, **8B.3.7**
 Chords, **12.5.1**
 Circular run-out, Table 19.1
 Circular solid section, Table 17.1
 Circular spacing, dimensioning of, **12.5.2.4**
 Circularity, Table 19.1
 Classification of fits, C-3
 Clearance fits, Fig. B-3, C-3.1.1
 Coaxiality, Table 19.1
 Colour, use of, **10.3.10**
 Combined dimensioning, **12.4.4**
 Commonly used fits
 for holes, Table C-4
 for shafts, Table C-4
 Compression spring, helical, **11C.3**
 Cones, dimensioning, **14, 14.4**
 Conventional representation of
 definition, **14.2**
 graphical symbol, **14.3**
 gears, Section 11D
 detail drawings, **11D.2**
 assembly drawings, **11D.3**
 axial section, **11D.2.1** (b)
 chain wheels, **11D.3.6**
 contours and edges, **11D.2.1**
 direction of teeth, **11D.2.4**
 pitch surface, **11D.2.2**

 root surface, **11D.2.3**
 teeth, **11D.2.4**
 external, **11D.3.1**
 internal, **11D.3.2**
 repetitive features, **10.3.7, 12.5.3**
 screw threads, Sections 11A, 11B
 general conventions, Section 11A
 representation, **11A.2**
 detailed representation, **11A.2.1**
 conventional representation, **11A.2.2**
 assembled threaded parts, **11A.2.3**
 indication and dimensioning, **11A.3**
 simplified representation, Section 11B
 screws and nuts, **11B.1.2**
 small diameter threads, **11B.1.3**
 assembled threaded parts, **11A.2.3**
 end view, **11A.2.2.2**
 hidden screw threads, **11A.2.2.3**
 limit of length, **11A.2.2.5**
 run-out, **11A.2.2.6**
 section of threaded parts, **11A.2.2.1**
 springs, Section 11C
 disc springs, **11C.6**, Table 11C.4
 helical compression springs, **11C.3**, Table 11C.1
 helical extension springs, **11C.4**, Table 11C.2
 leaf springs, **11C.8**, Table 11C.6
 spiral springs, **11C.7**, Table 11C.5
 torsion springs, **11C.5**, Table 11C.3
 Common feature, dimensioning, from, **12.4.2**
 Contour lines, **12.6.4.2**
 Coordinates, **12.4.3.2**
 Countersinks, **12.5.4.2**
 Cutting planes, **10.2.5**
 designation of, **10.2.4.3**
 position of, **10.2.4.3**
 section in one plane, **10.2.5.1**
 section in three planes, **10.2.5.3**
 section in two intersecting planes, **10.2.5.4**
 section in two parallel planes, **10.2.5.2**
 Cylindricity, Table 19.1

D

Dashed line, Table 6.1
 Datum feature, Fig. 19.2
 Datum letter, Fig. 19.1
 Datum target, symbol, Fig. 19.8
 Datum triangle, Fig. 19.2
 Designation of
 bars, Table 17.1
 bolts, Table 16.1
 holes, Table 16.2
 profile section, Table 17.2
 rivet, **16.3.3**
 Deviations
 for angular dimensions, Table D-3
 for chamfers, Table D-2
 indication in drawings, D-3
 positive, Fig. B-5
 negative, Fig. B-5
 for radii, Table D-2
 Diameter, **12.3.4.4**
 Dimension, **12.2.1.1**
 additional, **12.2.2.5** (a)

arrangement, 12.4
 auxiliary, 12.2.1.1 (c)
 functional, 12.2.1.1 (a), 12.2.2.7
 indication, 12.4
 of lettering, 7.4
 lines, 12.3.2
 non functional, 12.2.1.1 (b)
 out of scale, 12.3.4.3
 square, 12.3.4.4
 superimposed, running, 12.3.4.1 (b)
 theoretically exact, Fig. 19.3
 unit, 12.2.2.4
 Dimensional information, 12.2.2.1
 Dimensional values, 12.3.4, 12.4.2.4
 angular, 12.3.4.1
 indication of, 12.3.4.1 (b)
 out of scale, 12.3.4.3
 positioning, 12.3.4.2
 Dimensioning, Section 12
 an assembly, 12.5.5.3
 bolts, 16.3.5
 chain, 12.4.1
 chamfers, 12.5.4.1
 combined, 12.4.4
 common feature, 12.4.2
 cones, 14.4, Table 14.1
 by coordinates, 12.4.3
 countersinks, 12.5.4.2
 elements of, 12.3.1
 elements of revolution, 12.5.5.5
 general principles, Section 12
 hole, 16.3.5
 indication, other, 12.5.5
 indirect functional, 12.2.2.7
 limited area, 12.5.5.4
 limited length, 12.5.5.4
 method of, 12.3
 oblique, 12.3.4.1 (b)
 parallel, 12.4.2.3
 radii, 12.5.1
 repeated features, 12.5.3
 rivets, 16.3.5
 space, too small, 12.3.3.3
 spacing, angular, 12.5.2.2
 spacing, circular, 12.5.2.4
 special requirements, 12.5.5.6
 spherical diameters, 12.3.4.4
 spherical radii, 12.3.4.4
 tapered features, 14.4
 welds, 18.5
 Drawing sheet, Section 1
 borders and frames, 1.6
 centring marks, 1.7
 grid references, 1.10
 metric reference graduation, 1.9
 multiple sheet drawings, 1.11
 Drawing, typical examples of, Annex A

E

Edges of gear, 11D.2.1
 Elements of dimensioning, 12.3.1
 Elements on a larger scale, 10.3.8
 Elevation, 12.6.3.2
 Elevation datum, 12.6.4.3
 End product, 12.2.1.3
 End view of screw threads, 11A.2.2.2
 Equidistant features, 12.5.2
 Examples, Annex A

F

Fasteners, simplified representation, Section 16

Dimensioning, 16.3
 Features, 12.2.1.2
 First angle projection, 8B.3.1
 symbol, Fig. 8B.4
 Fits, B-4
 Fits commonly used
 for holes, Table C-4
 for shafts, Table C-4
 Flatness, Table 19.1
 Folding of drawing print, 4
 basic principle, 4.2
 for binding, Fig. 4.1
 for storing in filing cabinet, Fig. 4.2
 method, 4.4
 Frames, 1.6
 Functional dimensions, 12.2.1.1 (a), 12.2.2.7

G

Gear, 11D.1
 axial section, 11D.2.1 (b)
 chain wheels, 11D.3.6
 contour and edges, 11D.2.1
 engagement
 bevel, 11D.3.4
 cylindrical worm in cross-section, 11D.3.5
 external, 11D.3.1
 internal, 11D.3.2
 pitch surface, 11D.2.2
 root surface, 11D.2.3
 teeth, 11D.2.4
 teeth direction of, 11D.2.4
 Geometrical tolerancing, Section 19
 location tolerance, Table 19.1
 orientation tolerance, Table 19.1
 related features, Table 19.1
 single feature, Table 19.1
 Geometrical tolerancing, symbols for
 angularity, Table 19.1
 circular run-out, Table 19.1
 circularity, Table 19.1
 coaxiality, Table 19.1
 cylindricity, Table 19.1
 flatness, Table 19.1
 parallelism, Table 19.1
 perpendicularity, Table 19.1
 position, Table 19.1
 profile and line, Table 19.1
 profile and surface, Table 19.1
 straightness, Table 19.1
 symmetry, Table 19.1
 total run-out, Table 19.1
 Grid, Table 19.1
 Grid reference, 1.10

H

Half section, 10.2.7
 Hatching
 to indicate type of material, 10.2.2
 Hexagonal hollow section, Table 17.1
 Hexagonal solid section, Table 17.1
 Hidden screw threads, 11A.2.2.3
 Holes, Tables 16.1, 16.2 and 16.3
 Hole basis system, C-2.1.2

I

I-beam section, Table 17.2
 Indication of deviations
 order of, 13.4
 limit of sizes, 13.4
 Indication of, 13.5

dimensions, **12.4**
 dimensional values, **12.3.4**
 Indication of tolerances, **13.5**
 Indication of surface texture, Section 15
 Initial outlines, **10.3.9**
 Interference fit, Fig. B-3, C-3.1.3
 Interrupted views, **10.3.6**
 Intersections, **10.3.2**
 imaginary, **10.3.2.2**
 simplified representation, **10.3.2.3**
 true, **10.3.2.1**
 Isometric axonometry, **8C.4.1**
 Item list, **2.4**
 Item reference, **2.2**
 presentation, **2.3**

L

Lay out of drawing, **2.4.6**
 Leader lines, **6.9.1, 6.10, 12.3.2, 12.6.3.1**
 termination of, **6.10**
 Leaf spring, **11C.8**
 Lettering, Section 7
 designation, **7.5**
 dimensions, **7.4, Table 7.1**
 inclined, **7.4.4**
 Lettering A
 dimension, Table 7.1
 Lettering B
 dimension, Table 7.1
 Levels, indication of, **12.6**
 on horizontal (plain) views, **12.6.3**
 on sections, **12.6.3**
 on vertical section, **12.6.2**
 on vertical views, **12.6.4**
 Levels on site layout, **12.6.4**
 Limits and fits, Annex B
 Limits of partial views, **8B.3.9**
 Limit of sizes, **13.3.3**
 in one direction, **13.3.4**
 Lines, Section 6, **6.2.1**
 calculation of line elements, **6.8**
 combination of, **6.4.3**
 combination of, with the same length, **6.3.3**
 colours, **6.6**
 configuration, **6.4.3**
 construction drawings, **6.15, Table 6.5, Table 6.7**
 draughting of, **6.5**
 designation, **6.7**
 dimension, **6.4**
 element, **6.2.2**
 mechanical engineering drawings, **6.10, Table 6.8, Table 6.10**
 segment, **6.2.3**
 spacing of **6.5.1**
 width, **6.4.1**
 types of, **6.3**
 basic type, Table 6.1
 variations of basic type, Table 6.2
 Linear dimensions
 component of, **13.3**
 ISO symbols, **13.3.1**
 tolerances of, Annex D
 width, **6.4.1**
 deviation in, **6.4.2**
 Local sections, **10.2.8**
 Local views, **8B.3.10**
 Location tolerance, Table 19.1

M

Machining allowance, **15.4.4**
 Maximum material condition symbol, Fig. 19.1
 Methods of representation, **8B.3**

Multiple sheet drawings, **1.11**

N

Negative deviations, Fig. B-5
 Non-horizontal dimension lines, **12.3.4.1**
 Non-functional dimension, **12.2.1.1**

O

Oblique dimension line, **12.3.4.1 (b)**
 Oblique stroke, **12.3.3.1 (b)**
 Orientation tolerances, Table 19.1
 Origin indication, termination, **12.3.3**
 Out line, **12.3.2.7**
 Out of scale — dimension, values, **12.3.4.3**

P

Parallelism, symbol of, Table 19.1
 Parallelism dimensioning, **12.4.2.3**
 Partial section, **12.5.5.2**
 Partial views, **8B.3.9**
 Parts located in front of a cutting plane, **10.3.4**
 Permissible deviations, **13.3.2**
 Pipelines, simplified representation, Section 9
 coordinates, **9.5**
 crossing and connection, **9.2**
 deviation from the direction of coordinate axes, **9.6**
 dimensioning, **9.1.3**
 dimensions and special rule, **9.7**
 diameters and wall thickness, **9.7.2**
 dimensions for pipe bending machines, **9.7.10**
 direction of slope, **9.7.7**
 levels, **9.7.6**
 longitudinal and angular dimensions, **9.7.3**
 pipes with bends, **9.7.4**
 positions of ends of pipe, **9.7.8**
 radii and angles of bend, **9.7.5**
 redundant dimensioning, **9.7.9**
 graphical symbols, **9.8**
 lettering, **9.1.2**
 representation of, **9.1, Table 9.1**
 representation of equipment, **9.3**
 spacing, **9.1.1.1**
 tolerances, **9.1.4**
 types of lines, **9.1.1, 6**
 Pitch surface of gear
 Planning of assembly drawings, Section 3
 Position, symbol of, Table 19.1
 Positioning of dimensional values, **12.3.4.2**
 Positive deviation, Fig. B-5
 Principal view, **8A.2.4**
 Profile of any line, Table 19.1
 Profile of any surface, Table 19.1
 Projection
 lines, **12.3.2**
 Projected tolerance zones, symbol, Table 19.7
 Projection methods
 synopsis, Section 8A
 exploded view, **8A.2.3**
 pictorial representation, **8A.2.2**
 principal view, **8A.2.4**
 true view, **8A.2.2**
 survey of, **8A.3**
 geometrical orientation, **8A.4**
 invariable, **8A.5**
 systems, Table 8A.1
 orthographic representations, Section 8B
 choice of views, **8B.3.7**
 local views, **8B.3.10**
 methods of representation, **8B.3**
 first angle projection, **8B.3.1**

third angle projection, **8B.3.2**
 reference arrow layout, **8B.3.3, 8B.3.5**
 mirrored orthographic representation, **8B.3.4**
 indication of method, **8B.3.6**
 partial view, **8B.3.9**
 special views, **8B.3.8**
 axonometric representation, Section 8C
 position of coordinate system, **8C.2.1**
 position of object, **8C.2.2**
 axes of symmetry, **8C.2.3**
 hidden contours and edges, **8C.3.4**
 hatching, **8C.3.5**
 dimensioning, **8C.3.6**
 recommended axonometries, **8C.4**
 isometric axonometry, **8C.4.1**
 dimetric axonometry, **8C.4.2**
 oblique axonometry, **8C.4.3**
 cavalier axonometry, **8C.4.3.1**
 cabinet axonometry, **8C.4.3.2**
 planometric axonometry, **8C.4.3.3**
 central projection, Section 8D
 development of, **8D.7**
 method, **8D.4, Fig. 8D.1**
 one-point, **8D.4.1**
 two-point, **8D.4.2**
 three point, **8D.4.3**
 coordinate method, **8D.4.4**
 principle, **8D.5**
 principles and method of depiction, **8D.6**
 piercing method, **8D.6**
 trace point, vanishing point method, **8D.6.2**
 method A, **8D.6.2.1**
 method B, **8D.6.2.2**
 distance point method, **8D.6.3**
 scale point method, **8D.6.4**
 coordinate piercing method, **8D.6.6**
 symbols, **8D.3**

R

Radii, **12.5.1, D-2.2**
 Radius, **12.3.4.4**
 Rail section, Table 17.2
 Recommendations for selection of tolerances, C-5
 Rectangular opening, **10.3.3.2**
 Rectangular solid section, Table 17.1
 Reference arrow layout, **8B.3.3**
 Reference line, **6.9.2, 6.11**
 Reference section — designation of, **10.2.4.4**
 Reference temperature, **B-2**
 Related features, Table 19.1
 Removed sections, **10.2.6.3**
 Repetitive features, **10.3.7, 12.5.3**
 dimensioning, **12.5.3**
 Representation of
 (*see also* 'Conventional representation')
 bolts, **16.3.3**
 holes, **16.3.3**
 on projection planes, **16.2.1**
 ribs section, **10.2.4.6**
 rivets, **16.3.3**
 welds, **18**
 Removed sections, **10.2.6**
 Root surface of gear, **11D.2.3**

S

Scales, Section 5
 definition, **5.2**
 designation, **5.3**
 enlargement scale, **5.2.3**
 full size, **2.2.2**
 ratio, **5.2.1, 5.3**

Screw threads — Conventional representation
 (*see* 'Conventional representation')
 Section, **10, 10.2**
 arrangement of successive, **10.2.9**
 cutting plane, **10.2.5**
 half, **10.2.7**
 hatching to indicate type of materials, **10.2.2**
 local, **10.2.8**
 notes on hatching, **10.2.1**
 notes on sections, **10.2.4**
 other conventions, **10.3**
 adjacent parts, **10.3.1**
 conventional representation of square ends and openings,
10.3.3
 square ends, **10.3.3.1**
 square and rectangular openings, **10.3.3.2**
 elements on a larger scale, **10.3.8**
 initial outlines, **10.3.9**
 intersections, **10.3.2**
 true, **10.3.2.1**
 imaginary, **10.3.2.2**
 simplified representation of, **10.3.2.3**
 interrupted views, **10.3.6**
 simplified representation of repetitive features, **10.3.7**
 transparent objects, **10.3.11**
 use of colours, **10.3.10**
 views of symmetrical parts, **10.3.5**
 thin, **10.2.3**
 Selection of fits, guide for, Annex C
 Sheet type X, Fig. 1.4
 Sheet type Y, Fig. 1.5
 Simplified representation, bars and profile sections, Section 17
 complimentary rules, **17.2**
 schematic representation, **17.3**
 Single feature, Table 19.1
 Sizes — Designation of, **1.3**
 Sizes of drawing sheet, **1**
 exceptional elongated size, **1.3.3**
 sizes series ISO-A (First choice), **1.3.1**
 special elongated sizes, **1.3.2**
 Sizes and layout of drawing sheets, Section 1
 basic principles, **1.2**
 Sizes, selection of, **1.4**
 Spacing of lines, **6.5.1**
 Special indication, **12.5**
 Special views, **8B.3.8**
 Spherical diameters, **12.3.4.4**
 Spherical radius, **12.3.4.4**
 Spring, Section 11C
 (*see* 'Conventional representation')
 Square, **12.3.4.4**
 Square hollow section, Table 17.1
 Square opening, **10.3.3.2**
 Square solid section, Table 17.1
 Straightness, symbol, Table 19.1
 Structural metal work, **17.3**
 Superimposed running dimensions, **12.3.4.1, 12.4.2.4, 12.4.2.5**
 Surface texture, Section 15
 definition, **15.2**
 direction of lay, **15.4.3, Table 15.1**
 indication of machining allowance, **15.4.4**
 indication on drawings, **15.5**
 position orientation of the graphical symbol and its annotation,
15.5.1
 symbols, Fig. 15.1, Fig. 15.2, Fig. 15.3, **15.3**
 symbols with indication of roughness, **15.4**
 symbols with additional indications
 synoptic tables, **15.6**
 Symbols for
 bars, profile sections, Table 17.1
 diameter, **12.3.4.4**
 direction of lay, Table 15.1

geometrical tolerancing, Table 19.1
 holes, 16.3.2
 machining, 15.3.2
 projection system, Fig. 8B.4 & 8B.7
 rivets, Tables 16.1 & 16.3
 radius, 12.3.4.4
 spherical diameter, 12.3.4.4
 spherical radius, 12.3.4.4
 square, 12.3.4.4
 taper, 14.3
 weld, Section 18
 (*see also* weld symbols)

T

T-Section, Table 17.2
 Taper, 14.2
 Taper standard, 14.4.3
 Teeth of gear, 11D.2.4
 Terminations, 12.3.3
 arrow heads, 12.3.3.4, 12.3.3.5
 leader lines, 12.3.2
 sizes of, 12.3.3.2
 Thin sections, 10.2.3
 Third angle projection, 8B.3.2
 symbol, Fig. 8B.7
 Title block, 1.5
 position, 1.5.1
 Tolerance
 recommendation for selection, C-5
 symbols, 13.3.1(b)
 Tolerance for
 angular deviation, Annex D
 linear deviation, Annex D
 Tolerance on angular deviations, 13.6
 Tolerance of parts, B-3
 Torsion spring, 11C.5
 Total run-out, Table 19.1
 Transition fit, Fig. B-3, C-3.1.2
 Transparent object, 10.3.11
 Triangular solid section, Table 17.1
 True intersections, 10.3.2.1
 Types of drawings
 assembly, 3.2
 individual, 3.3
 Types of lines, 6.3, Table 6.1

U

Units, 12.2.2.4, 13.2
 Use of colour, 10.3.10

V

Values of deviations, 13.3.1.1
 Values by digits, 13.5.2
 Vertical views and sections, 12.6.2.3
 Views
 choice of, 8B.3.7
 exploded, 8A.2.3

front, 8B.3.7.1
 interrupted, 10.3.6
 local, 8B.3.10
 principal, 8A.2.4
 special, 8B.3.8
 symmetrical parts, 10.3.5
 screw threads, 11A.2.2.1
 true, 8A.2.2

W

Weld, Section 18
 complementary indications, 18.6
 dimensioning, 18.5
 positions, 18.4
 arrow line, 18.4.3
 reference line, 18.4.4
 symbol with regard to reference line, 18.4.5
 symbols, 18.3
 combinations, 18.3.2
 elementary, 18.3.1
 supplementary, 18.3.3
 Weld symbols, 18.3, Table 18.1
 backing run; back or backing weld (USA), Table 18.1
 butt weld, Table 18.1
 combination of, 18.3.2, Table 18.2
 concave fillet weld, Table 18.4
 convex double — V butt weld, Table 18.4
 edge weld, Table 18.1
 elementary, 18.3.1, Table 18.1
 fillet weld, Table 18.1
 flat (flux) single V butt weld, Table 18.4
 flat (flux) single V butt weld with flat (flush) backing run, Table 18.4
 fold joint, Table 18.1
 inclined joint, Table 18.1
 method of representation, Fig. 18.1
 plug weld, plug or slot weld (USA), Table 18.1
 position, 18.4
 relation between the arrow line and the joint, 18.4.2
 seam weld, Table 18.1
 single bevel butt weld, Table 18.1
 single bevel butt weld with broad root face, Table 18.1
 single J-butt weld, Table 18.1
 single U-butt weld (parallel or sloping sides), Table 18.1
 single V-butt weld, Table 18.1
 single V-butt weld with broad root face, Table 18.1
 steep-flanked single V-butt weld, Table 18.1
 steep-flanked single-bevel butt weld, Table 18.1
 spot weld, Table 18.1
 square butt weld, Table 18.1
 supplementary, 18.3.3, Table 18.4
 surface joint, Table 18.1
 surfacing, Table 18.1

Z

Z-section, Table 17.2
 Zeroline, B-6, Fig. B-1, B-2 and B-5