

The British Sundial Society



BULLETIN

No. 95.1

FEBRUARY 1995

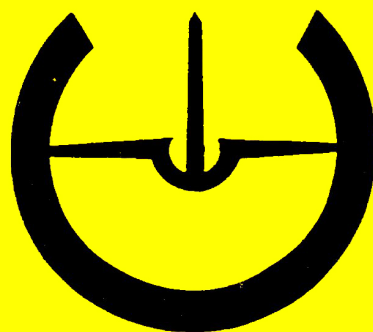

ISSN 0958-4315

HONORARY OFFICIALS OF THE BRITISH SUNDIAL SOCIETY

PATRON: THE RT. HON. THE EARL OF PERTH P.C.
PRESIDENT: SIR FRANCIS GRAHAM-SMITH
VICE-PRESIDENT: M. RENÉ R.-J. ROHR (France)
VICE-PRESIDENT: DR. MARINUS J. HAGEN (Netherlands)

COUNCIL:

CHAIRMAN: MR. CHRISTOPHER ST. J.H. DANIEL
GENERAL SECRETARY: MR. DAVID YOUNG
FINANCE: MR. R. A. NICHOLLS
MEMBERSHIP: MR. ROBERT B. SYLVESTER
BULLETIN EDITOR: MR. CHARLES K. AKED
DIAL RECORDING: DR. I. D. P. WOOTTON
EDUCATION: MRS. JANE WALKER
LIBRARY AND RECORDS: MRS. ANNE SOMERVILLE
COUNCIL MEMBER: MISS R. J. WILSON
SPONSORSHIP: MR. PIERS NICHOLSON
LIAISON: MR. ALAN SMITH

BULLETIN 95/1 - FEBRUARY 1995 - CONTENTS

Page

1. DIALOGUE - De Zonnewijzerkring, Société Astronomique de France, Oxford Today
2. Bewcastle Cross, by Charles K. Aked
9. The London Dialmakers, by John Moore
15. Proof of the Accuracy of the Capuchin and Regiomontanus Dials using the Polar Triangle of Navigation, by J.W. Findlay
18. Bifilar Gnomonics, by Frederick W. Sawyer III (USA)
27. Österreich Astronomischer Verein
28. Some Early Dialling Title Pages and Illustrations, by John Briggs
34. A Medieval Ecclesiastical Sundial at Rackeve, Hungary, by Lajos Bartha and Dr. Szilvia A. Holló
36. The Theory of Equivalent Sundials, by Erwin H. Overkamp (Germany)
39. Of Analemmas, Mean Time and the Analemmatic Sundial - Part 2,
by Frederick W. Sawyer III (USA)
44. Analemmatic Sundial, by Frederick W. Sawyer III
45. Readers Letters
48. Book Reviews - A Celebration of Cornish Sun Dials, Sundials - A Beginner's Guide,
Maltese Sundials
49. From Stretch Dial to the Double Helix, by John Moir
50. BSS Sundial Computer Program
51. Declination Finder, by Ray Ashley
52. The Scientific Instrument Society (SIS)

Inside back cover - Useful Addresses.

Cover Illustration - The Thomas Tompion sundial at Kew Gardens which is sited on the site of the house where the Reverend James Bradley made some of his astronomical discoveries such as the nutation of the earth. (The dial on the pedestal is a replica, the original is in the nearby house.)

DIALOGUE

DE ZONNEWIJZERKRING

Bulletin 94.3 reports that at the AGM in March Wiel Coenen took over from Marinus Hagen the task of recording sundials in the Netherlands. A description was given of the programme for the symposium on the 250th birthday of Eise Eisinga in Franeker.

Attention was drawn to clocks now on sale which are controlled by a radio signal, a talk was given on the Gauss formula for reckoning Easter in the Gregorian calendar. Other subjects discussed were finding the direction of Mecca and a model of the ecliptic. A member described work on an astronomical clock, an analemmatic dial and a carillon and sundial for the Town Hall in Ootmarsum.

A number of examples of the "Underwater Sundial" issued in 1983 by the Dutch Society are available from Thibaud Chaudin Chabot J.G.T.M., Mr. F.A. van Hallweg 3, 1181 ZT Amstelveen. Netherlands price F.30. Giro 1182942.

A member discovered a collection of sundials in an antique shop at Buren and reported on a possible exhibition of sundials in the clock museum at Zaanse Schans.

An obituary is given of Hendrik Hoitsma who was responsible for restoring the moonphases and high water indicator on the church clock at Arnemuiden and the planetarium in the museum at Middleburg. A memoir is given of Ignace Nauts who wrote several articles for the Bulletin and died at the age of 43.

A description is given of a dial on the public works office in Middleburg with a discussion on its possible dating. A further article describes sundials in Middelburg and a map of 1873 shows their location. The children in a school at Capelle a.d. IJssel have made a sundial in the playground and a description and photographs of this are given together with further description by the author. This is followed by a mathematical discussion on finding the exact noon and more on finding the direction of Mecca. The errors in a sundial at Deurne showed that the instrument was pointed 15° to the west of true north.

Another proof is given concerning material from Bulletins 92-4-7 and 93-3-18 on "spot-of-light" dials and is followed by an article on the construction of an ellipse and a hyperbola. Arabic prayer lines on a sundial are then discussed.

An article from the periodical "Heelal" is reproduced concerning sundials formed by crossed threads, with 9 illustrations. An illustration is given of a stone dial discovered at Harkstede, Groningen and another on the Palais de Justice at Rennes. The difference between horizontal and vertical dials is discussed in connection with a piece of metal engraved with hour lines 3 am - 9 pm.

The catalogue of dials in the Netherlands is continued, followed by a review of current literature and a list of members of the Society. E.J. TYLER

SOCIÉTÉ ASTRONOMIQUE DE FRANCE

Accompanying the notice by the COMMISSION DES CADRANS SOLAIRES of the 17th Autumn reunion, which was held on Saturday 15th October 1994, were details of the previous reunion. Fifty people were present on Saturday 9th October 1993, and proceedings opened at 10 am. There are 93 members, the average age being 63 years. A list, updated to 1st July, gives details of all the

participating members of the Commission des Cadrans Solaires.

Up to the end of December 1993, 9974 dials had been recorded, of which 8717 are French and 1257 foreign (to France). In 1993 445 new registrations of dials were made. The number of British dials recorded is only 146, so obviously an exchange of information between the British Sundial Society and the Commission des Cadrans Solaires is long overdue.

In BIBLIOGRAPHIE GNOMONIQUE No 15, three new works are described:

Cadran solaires de Paris, by A. Gotteland and G. Camus.

Cadran solaires des Alpes, by P. Putelet and P. Gagnaire.

L'Astrolabe, les astrolabes du Musée Paul Dupay, by Raymond D'Hollander.

Two brochures are mentioned "17 cadrans solaires à découper", by G. Oudenot, (17 cut-out dials in cardboard; and "Restauration de cadrans solaires peintes" by J. Fort, (Restoration of painted dials).

A full page of dialling articles listing articles in various publications, mostly French, follows. Similarly a list of gnomonic works recorded in the card index of the Société Astronomique de France is given, the reviewer was quite surprised to find about thirty-six books only. As a private individual, without setting out to form a dialling library, he considers his collection rather sparse with about one hundred books and pamphlets. There are at least five thousand dialling books and articles from which to make a choice.

OXFORD TODAY

In the Michaelmas issue 1994, Volume 7 No 3, pages 32-33 is a short article entitled "Only Happy Hours" by our member Dr. Margaret Stanier (Somerville 1938). It includes ten coloured illustrations. Naturally, as may be expected in an Oxford University publication, it deals with some of the dials to be found in Oxford Colleges. Those BSS members who attended the first British Sundial Society Conference held in Oxford in 1990 will remember the tour of Oxford sundials with some nostalgia, when the heavy rain of early morning thankfully gave way to sunshine to allow the afternoon tour to be undertaken with the majority of the dials actually casting meaningful shadows.

The dials illustrated include Merton in the Fellows' Quad, All Souls, Corpus Christi, Peckwater Quad, Christ Church; Brasenose, St. Cross Church, St. Antony's, plus three engraved glass examples from University College and the Museum of the History of Science Museum. The illustrations are excellently reproduced and cannot be repeated easily by means of personal photography since some dials, such as that on St. Cross Church tower are now sadly in need of restoration. Even the Corpus Christi dial is beginning to peel.

As Dr. Stanier remarks towards the end of her short text, a sundial is a most appropriate means of reminding viewers of past fellows or events, much better than some item which is seen but rarely, for example a silver dish or cup resented in memory of someone. As the Oxford dials adequately demonstrate, they give a permanent but ever changing decorative vignette of the daily passage of the sun.

BEWCASTLE CROSS

CHARLES K. AKED

One of the great mysteries of the Anglo-Saxon dialling world is that of the sundial on Bewcastle Cross in Cumbria. If we had the answers that this could yield, we would know much more about the history of dialling in Britain. Had the inscriptions on the cross been copied faithfully when they were still legible, the task of unravelling the problems posed by this enigmatic stone would have been made very much easier today. Sadly the task of attempting to decipher the runes cut into the stone was left until decay had destroyed most of the individual letters.

A SHORT HISTORY

Looking at the rural scene surrounding the little church today, the average visitor might be forgiven for thinking that nothing of importance had ever happened there. Figure 1 shows the site plan with the tiny church dedicated to St. Cuthbert built upon a large mound, part of the old Roman settlement.

About AD 120, the Romans built a permanent camp here, it was known by the name of *Banna*. In Tullie House Museum, Carlisle, is a carved stone from this camp which bears a dedication to Cocidius, and there are a number of other carved, inscribed and sculptured stones from this site preserved in the museum. Traces of an old Roman road from this camp to Hadrian's wall still remain to be seen in the undulations of the turf.

Until about AD 436, when the Romans were recalled to defend their Empire from invasion, Bewcastle was a busy place. By about AD 580, the site was taken over by a colony of Anglo-Saxons who invaded Britain when the Romans left. These in turn were usurped by the invading Norsemen. One of their chiefs decided to build a castle here which was known as Beuth's Castle. Later this name was modified to Bew Castle when a new castle was built.

When William the Conqueror annexed Britain, he dispossessed Beuth of his properties and granted these to one of his friends, William de Meschine. Beuth's castle

was later demolished, Bew castle being built in the reign of Edward I, utilising much of the Roman material still on the site. Of this castle there remains only a few parts of the outer walls, although these are still quite impressive. Bew Castle was a formidable barrier to the ambitions of the Scottish marauders until it was blown up by the Roundheads (Puritans) in 1641.

A farm house stands nearby, built from the stones of the demolished castle, and a little further away still is the church of St. Cuthbert, for which the builders made use of Roman stones. The church was erected in the reign of Edward I, and stood for a further 150 years after Bew castle was blown up. It was rebuilt in 1792, when only a small part of the chancel of the early church was spared from the restoration. It was last restored in 1901 by the Reverend E. Walker.

From the slight rise of land on which all these buildings stand, one can look out in all directions over the uncluttered English rolling countryside.

BEWCASTLE CROSS

The visitor must walk the final short journey to the church itself, see Fig 2, and as he enters the little churchyard, his eyes are drawn as if by magic to the tall pillar or obelisk standing a few yards from the church entrance. Its presence is omniscient yet the message is obscure. One stands in front of the monument in puzzled wonder, alas the pillar now remaining is only part of what was once a great and glorious cross.

Whilst some distance away, the visitor has the impression that the cross is still in good condition, and one might say that for its great age it is a miracle of preservation. As one draws nearer it is thus disappointing to find that the many details do not get clearer because the ravages of time have long since softened the outline of inscriptions and figures.

An examination of Figs 3 and 13 will convince the

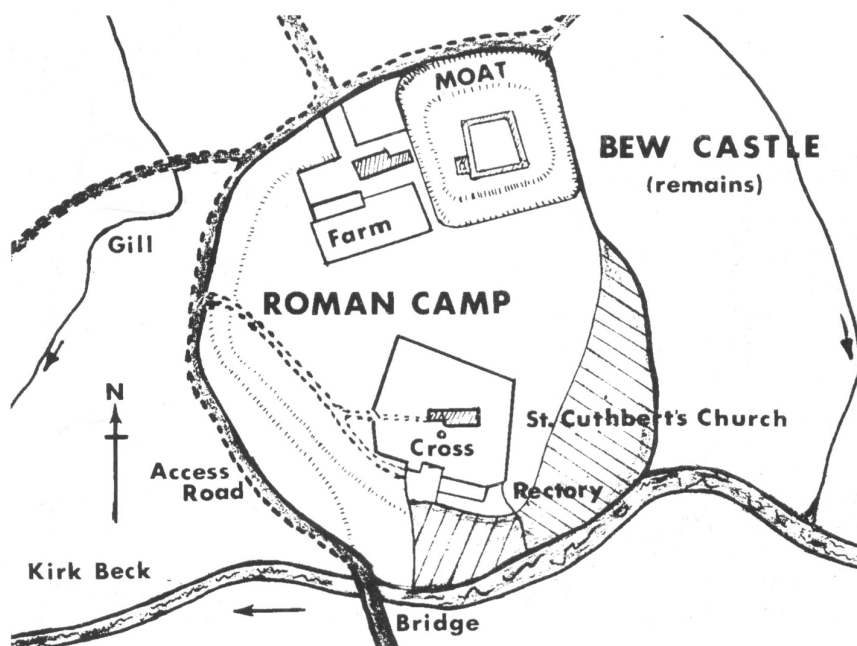

FIGURE 1: The area around St. Cuthbert's church at Bewcastle Cross.



FIGURE 2: Bewcastle Parish church of St. Cuthbert. The nearby farmhouse is just visible, lower right.

reader that the figures were magnificently designed and executed in the first place. The cross must therefore be meant to celebrate some great event or person. No one knows precisely what or who.

The earliest Anglo-Saxon historians include the Venerable Bede of Jarrow (672-735). In his writings he mentions the visit of Alcfrith, Prince of Northumberland, to the Synod of Whitby in AD 664 when Oswy of Northumbria decided in favour of the Roman date for Easter. Popular belief has long held that the cross was erected to the memory of Alcfrith, however he is not mentioned by other early chroniclers, notably Asser, biographer of King Alfred, a most noteworthy and accurate historian.

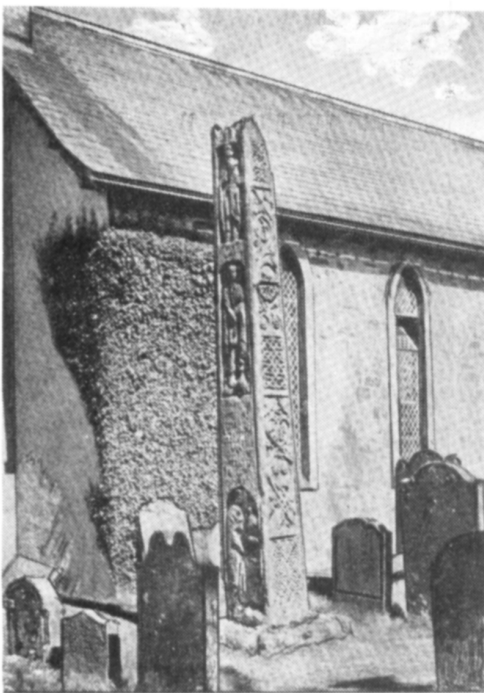

FIGURE 3: A photograph of Bewcastle Cross and church taken early this century.

There is a long catalogue of researches into the mystery of Bewcastle Cross, although these did not commence until 1601 when the Rector of Appleby Grammar School, Reginald Bainbrigg (1545-1606) complained to William Camden (1561-1623) about the lack of a mention of Bewcastle Cross in Camden's *Britannica* of 1586, then the most comprehensive guide to the counties of Britain. Bainbrigg described the cross and sent a copy of one word - "DITIBOROX".

At this point a slight digression is necessary to be able to inform readers that the cross has inscriptions which are formed by Runic characters. These are letters or characters based on the earliest Teutonic alphabet formed from Greek letters but modified in shape to allow these to be carved in wood or stone. Such runes were employed by the early Anglo-Saxons and Scandinavians. These inscriptions, even freshly cut, would have no significance to modern readers. It is possible that only a few educated persons at the time of the erection of the monument would have been able to decipher the meaning, most of the native population would have been unable to understand their own written language. Now that over a millenium has passed, the ravages of time and weather have virtually erased the cryptic signs. It is unfortunate that the west face of the monument carrying the main inscription is more exposed to the prevailing wind and rain than the other three sides, where on these the intricate interwoven patterns of the Anglo-Saxon culture are still clearly delineated. The study of these runes is a complex subject, and the interpretations of the experts have to be taken for granted by the majority of us, see Figs 9 and 10 (in part 2).

Six years later, Nicholas Roscarrock, of Naworth Castle, also wrote to Camden about Bewcastle Cross. Thus Camden's 1607 edition of *Britannica* includes the description - "Crux ... surgit, inscripta, sed letteris ita fugientibus vt legi nequequam possint". In other words, "A cross rises, with inscription, but with letters so fugitive that they cannot by any means be read". From this evidence it seems reasonable to assume that the inscriptions on Bewcastle Cross have not been legible for many centuries.

In 1685, the curate of Bewcastle church, Mr. Allen, wrote in reply to a letter from the Reverend William Nicolson (1655-1727), later Bishop of Carlisle. He stated that "the characters are now so miserably worn out ... that they are now wholly defaced and nothing to be met with worth my while." Nicolson did not believe Allen and so paid a personal visit to verify (or disprove) Allen's statement and had to admit "The former part of this narrative I found to be true". Nicolson paid a second visit in 1703, when he took a Mr. Benson to help decipher the inscriptions. This second visit is recorded in Gough's edition of *Britannia* when Nicolson stated "Though it looked promising at a Distance, we could not assuredly make out so much as that single line, which Sir Henry Spelman long since communicated to Olius Wormius". This observation confirms the words written earlier about the illusive clarity from a distance. It would have been a miracle if the line had been read since it had long before been removed, as will be detailed later.

George Smith (1693-1756), who taught mathematics at the town of Brampton a few miles away, took a personal interest in the Cross. He prepared a number of illustrations, the inscriptions being shown remarkably clear (and inaccurately rendered). His account is recorded in *The Gentleman's Magazine* of 1742.

Another local person, Captain G. Armstrong, who was born in the parish of Bewcastle; worked as a surveyor and draughtsman. He reported his findings on the cross in "An Account of a curious obelisk ... in ... Bewcastle", published in 1775 in *The London Magazine*. He stated in this account that "The figures and carving are very fair, but the inscription is not legible". As a draughtsman, his observations were more reliable than those of an ordinary layman.

Some time later, Mr. William Hutchinson, F.A.S., wrote an account of Bewcastle Cross in his book *The History of the County of Cumberland*, published in 1794. He accepted George Smith's transcription of the inscriptions of 1742 but sent his friend to decipher the runes. He reported that the runes were "confused and imperfect". Mr. Hutchinson sadly concluded: "Late visitors, as well as we, have great doubts whether any such characters (as shown by Smith) were ever legible".

Shortly afterwards a local antiquarian, Mr. Henry Howard, of Corby Castle near Carlisle, spent two full days closely examining the details of the cross, making careful measurements, and copying the remains of the inscriptions. He prepared a paper which he read at the Society of Antiquaries in May 1801. This paper was published in *Archeologia* in 1803. In this he states "The third, fourth and fifth lines are the most perfect. Towards the lower part scarce anything is to be made out. On the whole, indeed, little more than the vestiges of the inscription remain".

In the British Museum is a manuscript dated 1816 written by Samuel Lysons for *Magna Britannia*. At this time he was the Keeper of Records in the Tower of London. He was a very skilled artist and his drawings clearly show the bad condition of the main inscription. In 1836 the Reverend John Maughan B.A. (Dublin) became Rector of Bewcastle. He commenced research on the cross that he passed daily on his way to the church. Nevertheless he did not publish any of his findings until 1854 and he did not unearth anything of importance. His notes aroused the interest of the Reverend Daniel Henry Haigh (1817-79) who was the priest at Erdington church, Birmingham. He

requested rubbings of the inscriptions from Maughan, who supplied these but deliberately made them less than perfect. Haigh struggled with these and being dissatisfied, visited Bewcastle to prepare his own. The two men collaborated in an examination and reappraisal of the cross and its inscriptions, from which resulted the findings upon which present day opinions are founded. The decisions made were more subjective than objective. See Fig 10 for examples of Maughan's drawings of the runes of the main inscription.

The Reverend Haigh was a most scholarly man and of author of a work entitled *The Conquest of Britain by the Saxons*. This book contains much about the meaning of Runes. Haigh suggested a date of 665 AD as the date of the erection of the cross, and the first, with Maughan, to suggest that the cross was erected to Alcfrith.

In 1891 Charles Ferguson, President of the Cumberland Antiquarian Society, prepared his account - "Report on Injury to the Bewcastle Cross". In this he stated that "the appearance of the obelisk was hideous and pitiable". These views were reiterated by Mr. W.G. Collingwood MA, who reported in 1899 - "visitors unknown have poked and scratched at the letters without mercy". Perhaps this was a reference to the efforts to increase the contrast of the inscriptions by limewashing, and other methods used by previous researchers.

Next in line was the Reverend James King Hewison, another learned classical scholar. He first published the Runic Roods of Ruthwell and Bewcastle in 1914, followed by *The Romance of Bewcastle Cross* in 1923. Between these two dates, Professor G. Baldwin Brown and Professor Blyth Webster, in *The Arts in Early England* made announcements in 1920 and 1921 about the origin, date and purpose of these two monuments. The Royal Commission on Ancient and Historical Monuments of Scotland, Edinburgh, employed Brown and Webster in 1920, who then prepared a report which places Bewcastle Cross about 670 AD.

Hewison was extremely critical of Maughan, Brown and Webster. It must be admitted that Baldwin Brown's conclusions are based on circular reasoning after making unfounded assumptions. The Reverend Hewison stated in his earlier work that he considered that the Bewcastle and Ruthwell Crosses were erected as Peace Memorials under the influence of St. Dunstan following the overthrow of the Norsemen by King Aethelstan in the tenth century. His findings have not been accepted.

One of the more modern treatments of Bewcastle was produced by R.I. Page, published in *Nottingham Medieval Studies*, Volume IV, pages 36-57, 1960.

The previous outline covers some of the associated works dealing with the various aspects of Bewcastle Cross, the thrust of which is towards the elucidation of the meaning which was locked up in the Runic inscriptions. These are now seemingly without possible recovery because of the deterioration in the runes. However the precise meaning of the legible runes is open to question, whilst some of the pronouncements made by Baldwin Brown et al are based on very flimsy conclusions.

In all these writings, the part of greatest interest to diallists receives little or no mention, it is regarded of being of minor importance because the researchers were not interested in early timekeeping methods. For the sake of those wishing to pursue these matters further, it must be pointed out that to study all this material takes an enormous amount of time and effort. The collation here is all-

embracing from the point of view of the diallist and is included in order that the sundial on the south face of the monument may be considered in the context of the purpose of the monument. It would be quite pointless merely to examine the sundial itself to the exclusion of the rest of the column.

THE TRUE CROSS

Finally, to end the historical overview, the reader might be forgiven for asking why the constant reference is to Bewcastle Cross when the object appears to be only a vertical shaft. This brings us to another unsolved mystery because originally the shaft was another few feet taller and had a cross superstructure possibly similar to that of the well known Irish crosses. No one knows exactly when the cross was defaced or why but it fell before 1600. What remains is approximately 14½ feet in height. The top was in the churchyard for many years and a part of it suffered the ignominy of being built into a wall at one stage.

The present shaft was flat on the top and surmounted by a flat slab of stone which was possibly four inches in thickness and slightly overhanging the top of the column by an inch or so. Above this impost slab, or epistyle, was the head of the cross itself. A square hole was cut in the top of the column and through the epistyle, into which a corresponding tenon at the base of the cross passed. This was secured by lead to form a sound mechanical and water-proof joint. This point was, of course, much weaker than the main shaft and could have been damaged by water getting into the joint and freezing. It could also have been deliberately pulled off by any determined vandal.

When the head of the cross fell, it brought down the impost slab and broke away several inches of the top of the shaft on two sides. The effect of this can be seen in Fig 3 on the upper right. The impost slab was also broken in the fall and eventually came to the attention of Lord William at Naworth. He was known as Belted Will Howard, being Commissioner of the Border, visiting all parts of the country, a great lover of antiquities, and who delighted in collecting stones bearing inscriptions.

Lord William confiscated the stone for himself and in 1618 he showed the stone to Sir Henry Spelman and William Camden, which together with many others were incorporated in his garden wall at Nawarde, or Nawarth as it is now known. The impost slab was removed from the garden wall and despatched to Sir William Cotton via an intermediary, Lord Arundel (of the Arundel Marbles). Cotton wrote a letter to a friend - "I received this morning a ston from my Lord Arrundell sent him from my Lord William, it was the head of a Cross at Bewcastle. All the letters legable are thes in on line". [Note this is the epistyle, *not the true head of the cross*, which was lost without trace].

This inscription in Runic characters is given with important notes in two Cottonian manuscripts in the British Library, XVIII f. 33, and Julius F. VI f. 313. The curious thing is that the Runic characters on the epistyle appear to have been clear and the weathering had not affected them greatly up to 1618.

Unfortunately the epistyle, which was eventually removed to the British Museum with the Cottonian collections, has "disappeared". Although archeologists may have left no stone unturned to find the answers to the riddles of Bewcastle Cross, they have never found the missing epistyle in the dusty basements of the British

Museum.

It seems fairly clear that when Reginald Bainbrigg first wrote his description of Bewcastle Cross in 1601, the circumstances of the removal of the head of the cross were already forgotten. Thus Lord William is exculpated. Perhaps the partial destruction of the cross was through the Puritan clearance of churchyard crosses, or it may even have been the result of a very strong gale. The beautiful cross at Ruthwell a few miles away was completely smashed up and was used as building material. It has since been restored and is now safely under cover in the church itself. It might be considered as a twin of Bewcastle Cross except that it does not incorporate a sundial.

BEWCASTLE - A BRIEF HISTORICAL SKETCH

There was on sale in Bewcastle church, at the time of the writer's last visit in 1972, a five page pamphlet with the above title. In this Professor Collingwood states that Bewcastle Cross was made between 700 and 800 AD. This pamphlet neatly summarises the information describing the four faces of the monument and is repeated here with slight amendments.

WEST FACE

This bears four separate panels (see Fig 3).

- 1 Top. Contains a figure of John the Baptist bearing the nimbed *Agnus Dei* (Lamb of God). Above his head are the weathered remains of now indecipherable runes.
- 2 The figure of Jesus Christ standing upon the lion and adder, with His right hand uplifted in the act of blessing and His head surrounded by a halo. Above this panel are two lines of runes which are decipherable as "Gessus Kristus" (Jesus Christ).
- 3 A panel containing nine lines of runes which have been rendered as: "This tall standard of victory set up Hwaetred, Wothgar, Olfwold after (in memory of) Alcfrith lately king and son of Oswy. Pray for his soul". [There have been variations in the translations of these runes but as they are all based on the same basic assumptions, the differences are not great.
- 4 A panel of a falconer bearing a hawk on his left wrist, below is the bird's perch. The man appears to be wearing a cape. [Professor Stephens thought that the figure might have been intended to be that of Alcfrith himself, the latest theory is that it is of St. John the Evangelist, and the bird is meant to be the eagle of St. John. [It seems most unlikely to the writer that two figures of St. John would be carved on the same monument].

NORTH FACE

This bears five panels.

- 1 Top. A panel of vine scroll, consisting of a thick main stem, and three spirals, each ending in a bunch of fruit.
- 2 A panel of intertwined knot work.
- 3 A panel of chequer work, there are eight squares from side to side and twenty-five from top to bottom.
- 4 A panel of intertwined knot work.
- 5 A panel of double vine scroll with fruit and foliage.

On the spaces between these five panels are lines of runes which are now quite indecipherable. They are thought to name three persons - "Wulfhere", King of the Mercians and son of Penda; "Kuniburug", Alcfrith's Queen and Penda's daughter; "Kuneswitha", the Queen's sister.

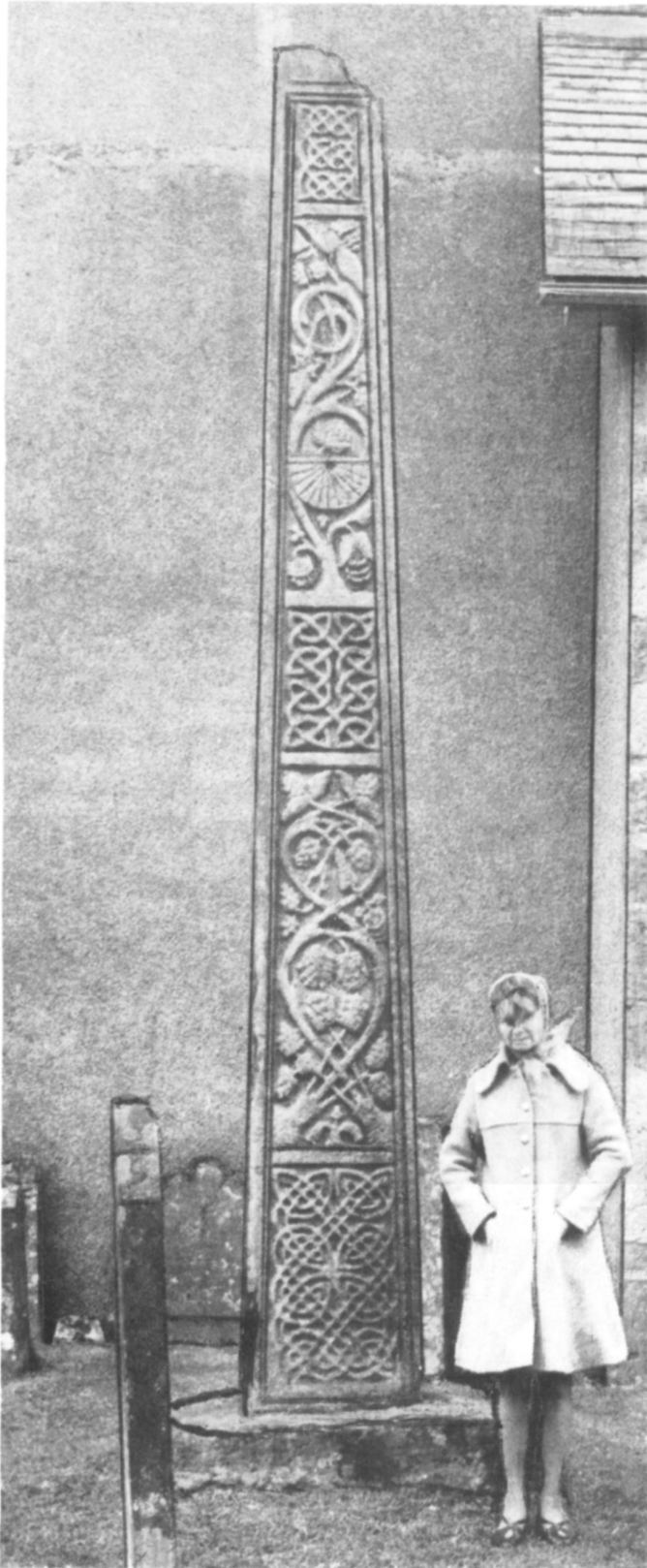

FIGURE 4: Bewcastle Cross photographed in 1972 when all the lines were still visible on the sundial.

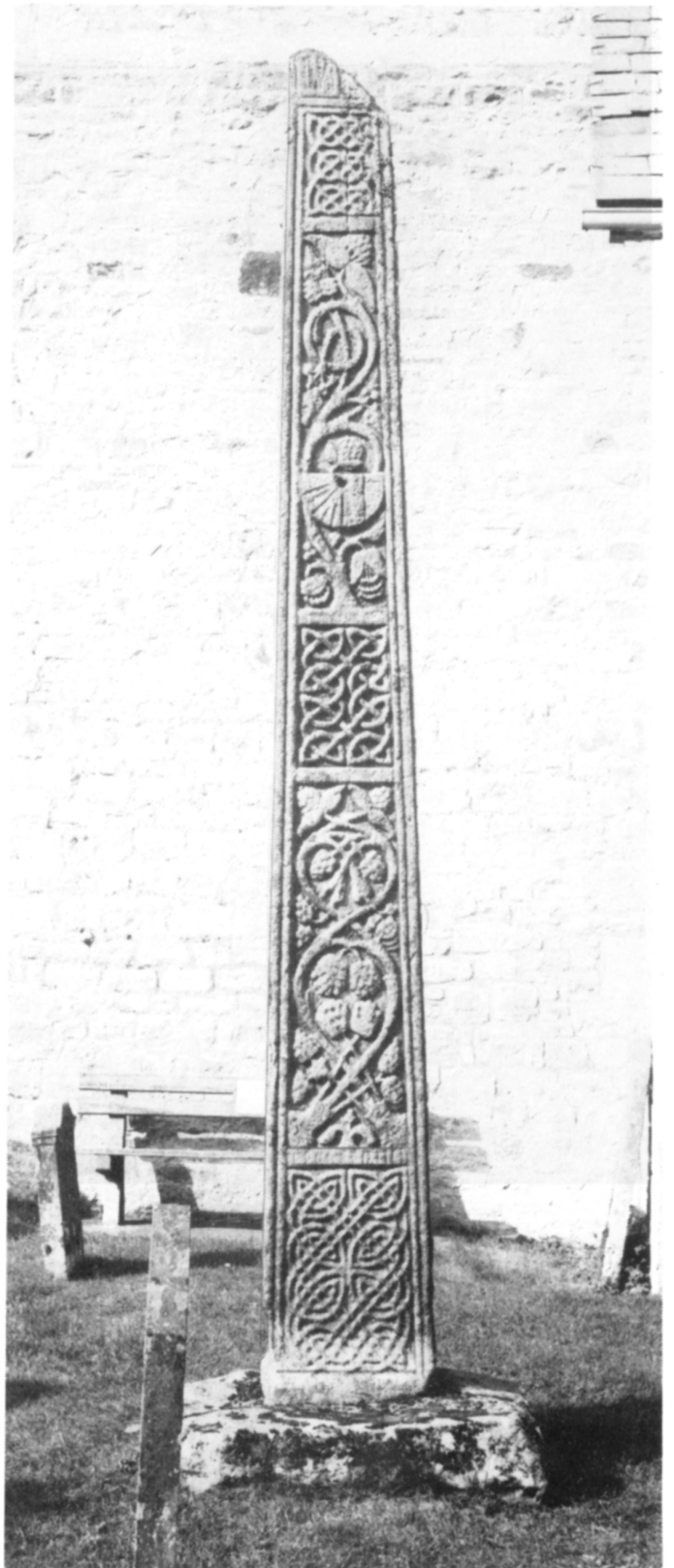

FIGURE 5: The south face of Bewcastle Cross in 1990.



FIGURE 6: The sundial of Bewcastle Cross in 1990, note the severe loss of lines.

EAST FACE

This bears one panel only.

The panel contains a vine scroll running the full length of the shaft. The vine is boldly designed and bears foliage and clusters of fruit. Near the top are two squirrels, below are two birds, probably a raven and a falcon; lower are two unknown creatures, and at the foot of the vine is an animal eating one of the clusters of grapes. [This design is similar to that on Ruthwell Cross which is not far from Bewcastle].

SOUTH FACE

The face is divided into five small panels (see Fig 3, 4 & 5).

- 1 Top. Panel of intertwined knot work, of the so-called Celtic design, above which are the remains of a line of runes.
- 2 A panel of scrolled ornament, containing a semicircular sundial resembling the dial over the Saxon porch of Bishopstone in Sussex. There is a similar dial over the entrance of Kirkdale Church in the North Riding of Yorkshire. The gnomon is missing from the cross. The rays mark 12 divisions between sunrise and sunset. See Fig 4.
- 3 A panel of intertwined knot work.
- 4 A panel of double scroll work, consisting of two grape bearing vines.
- 5 A panel of intertwined knot work.

On the spaces between each of the panels is a line of runes which have been transliterated as "In the first year of the King of this realm Ecgrith".

COMMENT

If the runes have been deciphered correctly, which is almost impossible for the inscriptions on the south face are very indistinct, then the date must be 670 or 671 AD since King Ecgrith ruled from 670-685 AD. The Venerable Bede, in his *Life of Saint Cuthbert*, writes "Ecgrith was killed ... in battle with the Picts, and was succeeded on the

throne by his brother Aldfrid, who had a few years before had devoted himself to literature in Scotia (Ireland), suffering a voluntary exile to gratify his love of learning".

THE SUNDIAL

Although it is now over twenty years since the present writer first saw Bewcastle Cross (on a sunless day), he must confess that the whole monument remains an enigma as far as he is concerned. On his first visit he was struck by the remarkable state of preservation of the whole but disappointed that whilst the intricate carving had been fairly well preserved, the inscriptions were almost useless. It was his opinion then, and now, that whilst the patterns, sculptures, and inscriptions blend harmoniously in a magnificent accord, the sundial does not fit into this melodious harmony with anything like the same ease. Yet the part of the stone on which the sundial was cut (was is used because it has almost disappeared, see Fig 6) is obviously part of the original cross and the scrolled ornament is most skilfully contrived to contain it.

Assuming that the dial was cut when the cross was first erected, then perhaps the inclusion of such a strange device was foreign to the artist who created this masterpiece. This small dial is over ten feet from the ground, a most unsuitable height for the average viewer of today, and men of the last millenium were generally smaller in stature. The designer and cutter of this magnificent monument was a man (or men) of such genius that such a position for the sundial would have been unthinkable.

After pondering on this dial for years, it seems to the writer on using gut feeling, that this dial is a later added feature, possibly replacing some original decorative feature which did blend into the general design without looking out of place. The execution of the work for the sundial does not appear to be of the same standard as the rest of the monument which is uniformly excellent. From this one might suppose that the sundial was delineated some time after the cross itself was completed.

If comparison is made with an early datable dial [circa 1065] as that at St. Gregory's Minster, Kirkdale, Yorkshire,



FIGURE 7: The sundial inside the porch at St. Gregory's Minster, circa AD 1065. Note the error in the engraving above where "N" has been substituted for "D" near the noon line.

it must be agreed that the tablet was executed by a less skilled hand than that which created Bewcastle Cross, see Fig 7. Yet the Kirkdale sundial is better both in conception and cutting than the Bewcastle dial. The much longer exposure of Bewcastle cross to the elements needs to be taken into account, but it appears cruder and earlier.

Figure 8 gives a conjectural form for the dial as originally cut in Bewcastle Cross which was based on an octaval division of the twenty-four hour day. It would have been a revolutionary device at the time. One might have expected that some inscription to explain the use of this would have been incorporated, as at Kirkdale, however there is no indication at Bewcastle. At Kirkdale the inscription "This is the Sun's marker at every tide" clearly indicates its purpose, at least to those who could have read the inscription.

In the pamphlet previously mentioned, the Bewcastle Cross dial is compared with that of Bishopstone which was at one time thought to have been cut in 685 AD because of the word "Eadric" cut into the dial. Eadric was a South Saxon prince who lived at that time. The dial form is similar but the Bishopstone dial is certainly much later, possibly some time before the Norman Conquest of 1066 AD.

(To be continued in BSS Bulletin 95.2)

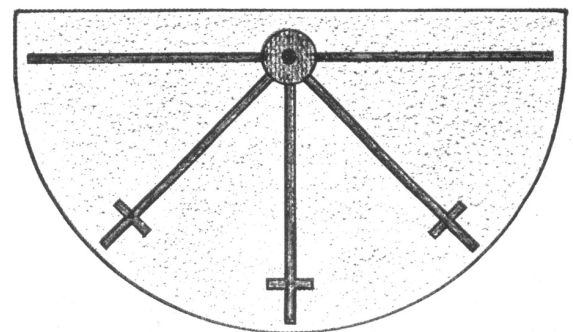

FIGURE 8: The conjectural original form of the Bewcastle Cross sundial.

THE LONDON DIALMAKERS

JOHN MOORE

The tradition of dialmaking in London covers a wide period of time and a great many makers. Most of these dialmakers were primarily instrument makers and produced, not only sundials, but often a wide range of scientific and mathematical instruments. From the mid-17th century, the various craftsmen in London formed themselves into guilds and laid down strict rules for obtaining and maintaining their memberships. It was one way to keep out undesirable members including those from the provinces seeking work in London, and its rules imposed strict quality controls on their workmanship. Any piece not meeting the required standards could be confiscated and destroyed by guild officials. In general, the guild system did much for the overall standard of tradesmen and their products and made London instruments much prized both in Britain and overseas.

There was no Instrument Makers Company at that time and instrument makers were to be found in various other companies such as the Clockmakers Company, and rather surprisingly to us today, the Grocers Company. In fact, the Grocers Company was the main guild for instrument makers at that time. (Ref. 1.)

THE SIXTEENTH CENTURY

Portable sundials were known prior to this century but extant examples and the names of their makers are mostly unknown. Those that were produced were made individually in universities or monasteries by learned men and not generally as commercial items. Some simple and possibly mass produced portable dials are known, particularly those salvaged from wreck of the Mary Rose. These were made of wood and consequently few from this period have survived. It was not until the time of Elizabeth I, 1558-1603 that instrument making really began to flourish.

It is the three famous makers of this period, Humphrey Cole, James Kynfin and Charles Whitwell that we know

best as makers of sundials.

Cole was the most famous and examples of his work are to be found in many museums. It is certain that he was a fine and accomplished instrument maker as is evidenced by the quality and execution of his works.

Kynfin (in its various spellings) is remembered best for his bad workmanship rather than his good. The quality of his engraving on one instrument would vary dramatically. It is thought by some that he was probably a drunkard. One of his instruments is signed KYNVYN, the first few characters being perfectly executed but the remainder sloping and diminishing in size. We can only conjecture that he finished the engraving following a lunch time visit to a tavern. (Ref. 2.)

THE SEVENTEENTH CENTURY

It was the early years of the century that saw the first instrument makers producing portable sundials in any quantity. Their dials were of high quality, being finely made and were generally accurate in their time recording.

The best known makers of the period were Elias Allen, Edmund Culpeper I, his son Edmund II, Edward Culpeper, Walter Hayes, Henry Sutton, Thomas Tompion, John Worgan, and Henry Wynne. Joyce Brown in her book (Ref. 1.) shows the close relationships that existed between many of these makers. A line of descent through apprenticeship may be traced from Charles Whitwell, through Elias Allen, Walter Hayes, John Worgan and the two Edmund Culpepers' in turn. Further famous makers followed this lineage into the 18th. Century. In the Whipple Museum in Cambridge is an horary quadrant by Edmund Culpeper with a sundial on its reverse. (Ref. 3.) During restoration, the volvelle supporting the gnomon was removed and trial engravings were found beneath it including the name of Culpeper. A similar quadrant by Hayes has recently been found and this too has hidden engraving beneath the volvelle. (Fig. 1.) It is interesting to surmise whether this Hayes quadrant was engraved by Culpeper during his apprenticeship to Hayes or if Hayes passed on the habit to the young Culpeper.

Henry Sutton is perhaps the best known maker from the 17th. Century. His work covered a wide range of instruments but he is best known for his horary quadrants and his ring dials.

Thomas Tompion was the famous 'father of clockmaking' towards the end of the century. His main output was in clocks and watches but a few sundials of his are known to exist. The best known is a superb garden dial at Hampton Court. It shows clearly the wonderful quality of his workmanship for which he is justly famous. Portable dials by him are quite rare but the British Museum in London has two virtually identical examples, one in gold and the other in silver. (Ref. 4)

John Worgan was a fine instrument maker producing portable sundials and garden dials of the highest quality. One interesting feature of his work that appears on all but one instrument that he made, (known to the author), is a beautifully engraved English Rose. (Fig. 2.) Other makers of the period including Edmund Culpeper also used a similar symbol but not so exclusively as Worgan.

Henry Wynne is well known for his ring dials and the small book that he produced to explain how to use them.

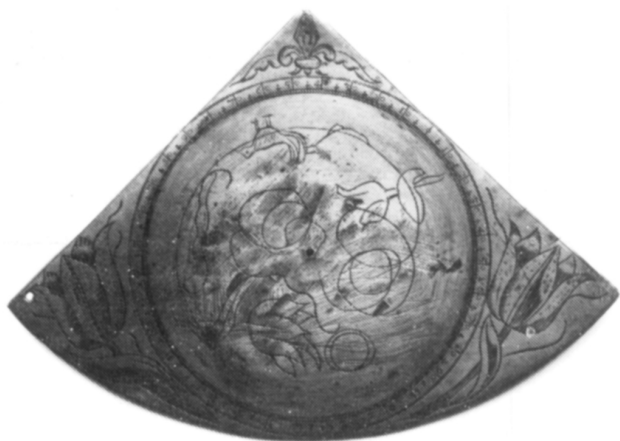

FIGURE 1: Quadrant by Walter Hayes showing engraving that was hidden beneath the sun dial volvelle.



FIGURE 2: Detail of Tudor Rose on Sector by John Worgan.

(Ref. 5.) Further details have already been given in a previous article about Ring Dials.

THE EIGHTEENTH CENTURY

A considerable number of dials were produced in London during this period by a large number of instrument makers. Very few of them made sundials alone. Their trade was widely spread throughout the field of scientific and mathematical instruments. It was usual for each instrument maker to have his own shop from which to sell his wares. In London, most were to be found in the area around Fleet Street. Evidence shown by the Trade Cards and Advertisements of the time, indicates that most makers could supply virtually any instrument on demand. It is unlikely that each of them would actually manufacture all of the items offered and there must have been a considerable amount of trading between them. It is quite difficult actually to prove this point unless one particular maker had an individual style that could easily be identified. The vendor would, in nearly all cases, add his own signature to the instrument. Similar practices have been found amongst the clockmakers of the period. One case known to the author is of a bracket clock signed by Henry Jones but, stylistically, it must be the work of Joseph Knibb. Jones, however, has completed the work by adding the finishing touches including the decorative engraving plus his own signature.

Some London dials are signed by Masig, but these are clearly the work of one or both of the Augsburg makers, Johann Martin and/or Johann Willebrand. It is believed that Masig was their local agent in London and as far as we know there are no dials of his own manufacture. (Ref. 6.)

The range of dials produced in London covered almost every type imaginable with a few notable exceptions. The most prominent exception is the pillar dial that was most commonly made in France and Italy, but probably never in London. Another type is the mechanical equinoctial dial. It is not commonly found but when it is, it most often comes



FIGURE 3: Universal Equinoctial Mechanical Dial by Thomas Wright.

from the Continent and sometimes Dublin. There are exceptions to every rule, dials of this type by Thomas Wright of London are known to exist. (Fig. 3.) The details of this dial are worth description. Its base contains a large compass with a London magnetic variation of 14° west. Around the compass is engraved the Equation of Time and it is signed 'Made by T : Wright Instrum^l. maker to ye KING'. The chapter ring itself which is divided into the full 24 hours can be inclined from 20° to 90° . Around the edge of the chapter ring are gear teeth that engage with a small pinion on the supplementary minute dial. Once the dial has been correctly aligned by the compass to face south with the correct latitude set, the small finger of a gnomon is erected and the minute dial turned until the shadow lies exactly across its centre, i.e. the 30 to 60 minute line. The time is then read by combining the hour reading shown by the pointer opposite with the minute dial reading. During the winter months the sun's altitude will be too low to throw a shadow along this line, so Wright has thoughtfully put another parallel line beneath the minute dial. Other dials of this kind have different gnomon arrangements but their operation remains essentially the same.

Similarly, the ivory diptych dial, generally coming from Dieppe and Nuremberg was not, as far as we know, made in London. One later, but rare exception by R. & J. Beck was illustrated in an earlier article. (Ref. 7.)

Several 'Butterfield' style dials were made in London, most notably by Thomas Heath. As with most English portable dials, these were usually of brass, unlike the majority of those from Paris that were frequently of silver. These English Butterfield's were generally of much higher technical standard and were not as ornate as their French counterparts.

If any dial could be said to be a typical London (or English) dial it would be the Universal Equinoctial dial of the form illustrated in Fig. 4. Its style varied considerably but it was nearly always heavily built with a large compass, and in use, capable of quite accurate time recording. The

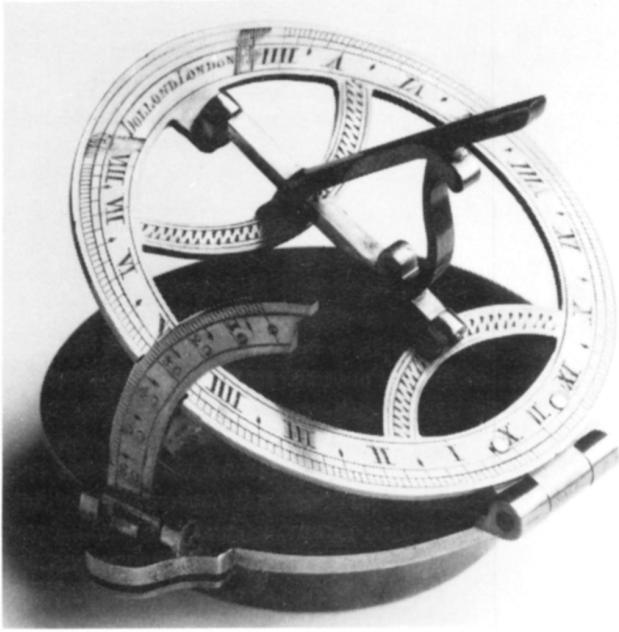

FIGURE 4: 'London' Style dial by Dolland.

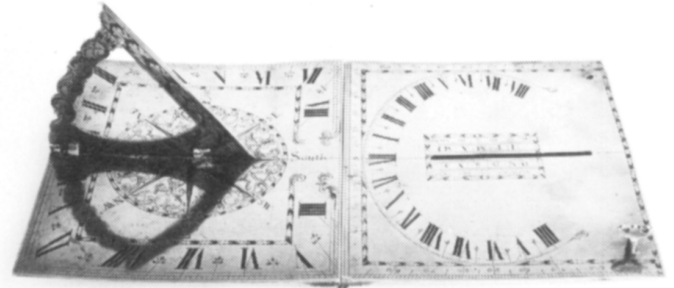

FIGURE 5: Analemmatic Dial, unsigned, c1750.

'equation of time' was frequently engraved around the edge of these dials and the usual list of European towns with their latitudes underneath. Some, designed for wider travel, included towns in the 'new colonies' of the British Empire.

A particularly interesting form of dial that was occasionally made in London is the analemmatic type. (Fig.5.) The analemmatic dial in this form is believed to be the invention of Thomas Tuttell (Tuttel) of Charing + in 1698. It is one type of portable dial that does not need a compass for correct alignment. Essentially it is two dials in one, a standard horizontal dial with its gnomon parallel to the Earth's axis, and a second analemmatic dial with a vertical pin or blade gnomon in the centre of an elliptical chapter ring. The analemmatic gnomon, which is missing on this example, needs to be adjusted to the appropriate month to correct for the seasonal change in the sun's altitude. Usually the two dials are joined together, often on two hinged plates to allow for storage. Each of the two dials is complete in its own right, but each, without a compass, cannot be used. In use, the dial plate is turned so that the shadows from the two gnomons record the same time on their separate scales. This form of analemmatic dial, as with several other types of dial, notably the ring dial, does not give any indication as to whether the observed time is before or after noon. The user must therefore use other clues to achieve the correct setting. Once set, the main dial plate should be perfectly aligned North - South. A dial such as this was intended for use at one particular latitude but was usually fitted with screw feet for levelling so that other latitudes could be set. A small plumb bob, again missing, usually hangs in the triangular cut-out section of the gnomon, its tip indicating the angle of the plate against the scale along its bottom edge. In practice latitudes of $\pm 25^\circ$ could usually be accommodated by tilting the dial. The sliding gnomon fitted to the analemmatic portion when set to the correct date also indicates the angle of declination of the sun and normally has a second scale showing the zodiac date. On the reverse, where the gnomon

protruded through the plate was often a scale to show the hours of sunrise and sunset. These figures were, of course, only true for its one intended latitude. Also on its reverse side there would frequently be found a perpetual calendar showing golden numbers, etc. (Fig. 6.)

A perpetual calendar is often a useful indicator of the date of manufacture of a dial. (Ref. 8.) If it is an English dial, we know that the calendar was changed in 1752. A quick check on the date for the 'first point of Aries' will give March 10th or 11th for the older Julian Calendar and March 21st for the current Gregorian Calendar. Where the zodiac signs are missing it may still be possible to check these dates by comparing the points on a calendar scale where the two scales cross. If the 21st March is opposite to 21st September it is Gregorian. If the 11th March was opposite 11th September it would be Julian. A perpetual calendar would often indicate the years of its intended use, giving a good check against recorded dates for its maker. The silver dial by J. Simons of London carries a perpetual calendar on its lid. (Fig. 7.) The earliest date shown may be found from the inscriptions:- 'March begins on in the Year 1700 &', 'Thurfday 70. 81. 92. 98.' It is therefore probable that it was made in the year 1770. This form of calendar is attributed thus:- 'The Univerfal Time Table, S Kingdon inv.' Many of the dials of this period were made so that the compass bowl could turn with respect to the chapter ring to enable the latest compass declination to be set. At this time the rate of change of compass declination was at its maximum being around 1° for each 4 year period.

THE NINETEENTH CENTURY

The portable sundial was being made in quite large quantities throughout the 19th century. It was essential to have some means of setting both clocks and watches. Ownership of mechanical timekeepers was now widespread and many gentlemen would own at least a pocket watch. Watches were widely available at affordable prices, being made in large quantities in parts of Lancashire and other

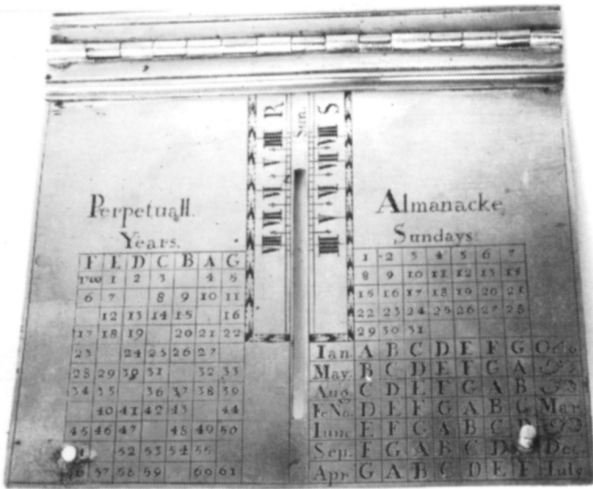

FIGURE 6: Calendar on reverse of Analemmatic Dial.



FIGURE 8: Magnetic Compass Dial by S. Porter, 1824.

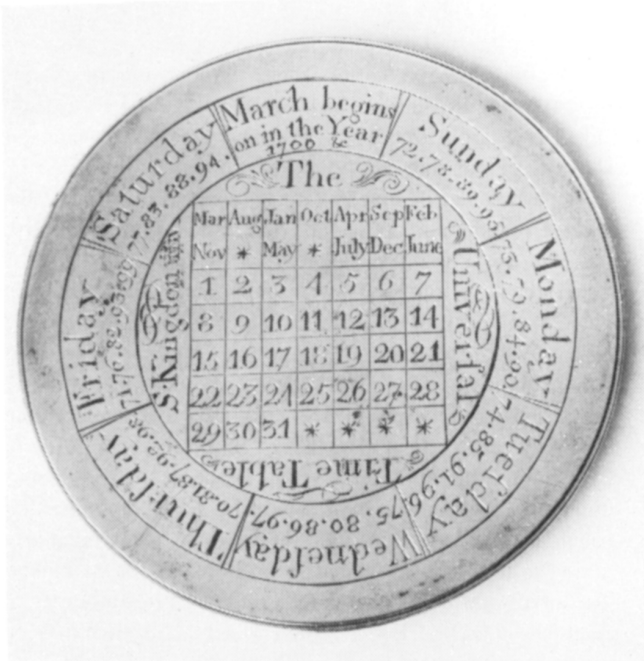

FIGURE 7: Perpetual Calendar on lid of dial by J. Simons.

areas. Clocks at this time were more likely to have come from France, Germany and the ex-colony of the Americas. It is not known how many persons would own a pocket sundial as the correct time was frequently available from the local church clock. We can only surmise that the figure would have been many tens of thousands. Naturally, these mass produced dials were much simpler and utilitarian. The higher accuracy dials continued to be made but could, as before, only be afforded by the richer members of society.

An interesting dial of the period was the magnetic compass dial. It was made by at least two manufacturers, Samuel Porter and Essex & Co. Many of these were unsigned but those that were had a printed scale and would often carry a 'signature' such as:- 'S. Porter Fecit Feby, 16

1824' and 'Entered at Stationer's Hall'. (Fig. 8.) These simple dials consisted of a card supporting the gnomon with a thin bar magnet attached to the underside held in position by a piece of paper that was pasted over it. They had no means of adjustment for any change in magnetic declination which was at a maximum of around 24°W at this period and so was changing only slightly each year. The compass card assembly was supported from the base by a pin to allow it to rotate. It was a fixed latitude dial and of dubious accuracy, but very convenient and easy to read without any setting up being required. Examples were normally in simple turned wooden cases but occasionally one will be found in an ivory case as is the one illustrated. This dial, unfortunately, is missing its protective glass dome.

An accurate form of sundial was produced later in the century that was capable of the measurement of the moment of noon to within seconds. This was known as the Dipleidoscope. It used prisms and formed two split images of the sun that coincided exactly at noon as long as it was correctly set on the North - South axis. (Ref. 9.) (Fig. 9.)

With the introduction of Railway Time in the late nineteenth century it became necessary to have clocks and watches set to same time throughout the country. The railway telegraph then became the prime disseminator of the Nation's time keeping, and towards the close of the century the pocket sundial and most other types of sundial became redundant. It was still necessary to find the Nation's time from the sun, but this could now be done in London at The Royal Observatory at Greenwich from where it was transmitted throughout the country.

THE LONDON PORTABLE DIALMAKERS

The following list of London makers are those found in the author's own research and is not necessarily complete. Certain names have been excluded, in particular, those makers whose trade cards or advertisements mention portable or pocket dials and those who are only known to

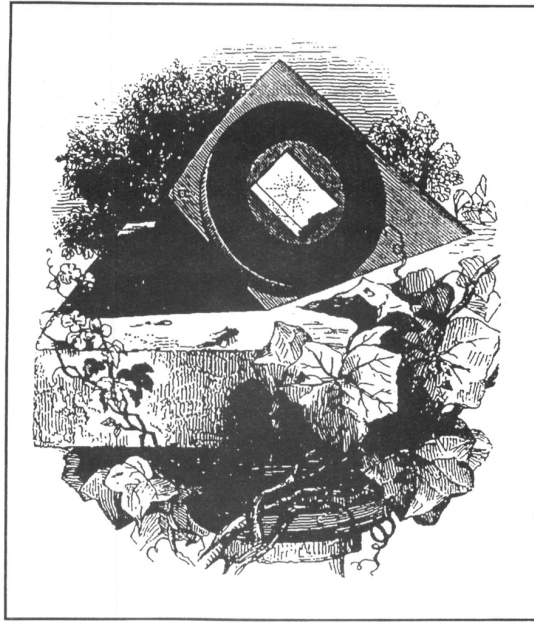

FIGURE 9: Illustration from Dent's booklet showing his Dipleidoscope mounted on an ivy covered pillar.

have made other sundials. The list that remains, is of makers with known examples of portable dials to be found in museums, illustrated in books, auction catalogues, in private collections or dealers stocks.

In some cases, the maker may have signed only his surname, or his first name may be the same as another member of the family. In these cases it has been necessary at times to make a reasonable guess as to whether it is father, son or other relative. The dates given for each maker have been taken from various sources, most notably the two important listings by E.G.R. Taylor. (Ref. 10 & 11). For this reason no further biographical information has been listed as it is readily available in these and other works.

In 1995, a new work will be published that should cover all known British instrument makers. (Ref.12). At the time of writing, its contents are not available to the author.

SURNAME	FIRST NAME	DATES
ADAMS	Dudley	c 1760-1654
ADAMS	George, Snr.	1704-1773
ADAMS	George, Jnr.	1750-1795
ALLEN	Elias	fl 1606-1654
ALLEN	John	fl 1632-1637
BAKER	Robert	fl 1685-1712
BATE	Robert Bretsell	fl 1807-1843
BARKER	F. & Son	c 1900
BECK	R & J	19 cent
BEDFORD	Helkiah	fl 1660-1680
BIRD	John	1709-1776
BITHRAY	Stephen	fl 1827-1846
BLEULER	John	1757-1829

CARY	William	1759-1825
CASELLA	Lewis	fl 1833-1838
COGGS	John	fl 1690-1740
COLE	Benjamin, Snr. (or Jnr.)	1695-1755, (1727-1813)
COLE	Humphrey	1530?-1591
COX		c 1800
CULPEPER	Edmund	1660-1738
CULPEPER	Edward	fl 1666
DEANE	William	fl 1690-1712
DENT	Edward John	1770-1853
DIXEY	C. W.	19 cent
DOLLOND	Peter	1730-1820
DUTTON	Richard	fl 1663?-1682
ELLIOTT	Bros.	fl c1840
ELMES	William	fl 1667-1672
ENGLAND	John	ante 1692
ESSEX	C & Co.	c 1830
EVANS		late 18 cent
FERGUSON	James	1710-1776
FLOWER	Samuel	c 1750
FRAZER	A & H & Sons	19 cent
GILBERT (& GILKERSON)		
	John	fl 1726-1763
GLYN(NE)	Richard	fl 1696-1755

GOTTMAN	Daniel	c 1770
GRAYDON	George	fl 1820-1839
GREATOREX	Ralph	1625-1712
GRICE	William Hawks	fl 1815-1825
HAMLIN	William	fl 1792-1814
HAMMOND	J	fl 1731
HANKS	W	19 cent
HARRIS	Thomas & Son	fl 1806-1846
HAYES	Walter	fl 1651-1692
HEATH	Thomas	fl 1714-1765
HEATH & WING		fl 1740-1771
HICKS	Joseph J.	fl 1814-1822
HORNE & THORNWAITHE		19 cent
JACKSON	Joseph	fl 1730-1770
JONES	William & Samuel	1784-1838
KYNFIN (KYNVYN, KYNVIN)	James	fl 1569-1610
LIFORD (& SCOTT)	J (&B)	
LITTLE	G	20 cent
LONG		early 19 cent
MARKE(S)	John	fl 1665-1679
MARTIN	Benjamin	b 1704, 1714-1782
MASIG		fl c 1700
NAIRNE	Edward	1726-1806
NAIRNE & BLUNT		fl 1774-1822
NAISH	John	fl 1707
NEGRETTI & ZAMBRA		(1819-1879)
NEMES	T & J	fl c1700-1740
NEWMAN	J. (James or John)	fl 1793-1827 or fl 1816-1838)
NEWTON & Co.		c 1910
PARKER	S	c1820
PARSONS	William	1759? 1822-1838
PHILIP	George & Sons	c 1910
PORTER	Samuel	c 1825
PRITCHARD	Andrew	fl 1804-1841
RAMSDEN	Jesse	1735-1800
ROWLEY	John	fl 1698 d1728
RUBERGALL	Thomas	fl 1810-1846
SAIGHT	T	late 19 cent
SCOTT	Benjamin	fl 1714-1733 (1751?)

SEARCH	James	fl 1780
SHUTTLEWORTH	Henry Raines	c 1730-1811
SIMONS	James	fl 1791
SISSON	Jeremiah	fl 1736-1788
SISSON	Jonathan	1694?-1749
SMITH		18 cent
SUTTON	Henry	fl 1637 d1665
T(H)OMPSON	Anthony	fl 1638 d1665
TOMPION	Thomas	1639-1713
TROUGHTON		late 18 cent
TROUGHTON & SIMMS		1826-1836
TUTTELL (TUTTEL)	Thomas	fl 1695-1702
WATKINS	W	19 cent
WATKINS & HILL		fl 1806-1846
WATLINGTON	Abraham W ?	
WEBB	John	1760-1846
WEST		late 18 cent
WHITEHEAD	Richard	fl 1663-1693
WHITWELL	Charles	fl 1591-1606
WORKMAN	Benjamin	fl 1805
WRIGHT	Thomas	fl 1686-1748
WYNN(E)	Henry	fl 1654-1709

REFERENCES

- Ref.1: Brown. J. Mathematical Instrument Makers in the Grocers Company.
- Ref.2: Dawes. H. Marks, Doodles & Scratchings. *Bulletin of the Scientific Instrument Society*, Vol.19, 1988.
- Ref.3: Bryden. D.J. Sundials and Related Instruments. *Catalogue of the Whipple Museum*.
- Ref.4: Ward. F.A.B. A Catalogue of European Scientific Instruments....., Items 52 &53.
- Ref.5: Wynne. H. The Description of the General Horological Ring or Universal Ring-Dyal. 1682.
- Ref.6: Moore. J. The Augsburg Dials. *BSS Bulletin*, 93.3.
- Ref.7: Moore. J. The Ivory Diptych Dial, Part 1. *BSS Bulletin*, 93.3.
- Ref.8: Moore. J. The Ivory Diptych Dial, Part 2. *BSS Bulletin*, 94.1.
- Ref.9: Dent. E.J. A Description of the Dipleidoscope or Double Reflecting Altitude Instrument. 1843.
- Ref. 10: Taylor. E.G.R. The Mathematical Practitioners of Tudor & Stuart England.
- Ref. 11: Taylor. E.G.R. The Mathematical Practitioners of Hanoverian England, 1714 - 1840.
- Ref. 12: Clifton. G. Directory of British Scientific Instrument Makers, 1550 - 1851.

PROOF OF THE ACCURACY OF THE CAPUCHIN AND REGIOMONTANUS DIALS USING THE POLAR TRIANGLE OF NAVIGATION

BY J.W. FINDLAY

In the April 1961 Journal of The Royal Astronomical Society of Canada an interesting article was published on the Capuchin portable sundial which aroused interest among the cognoscenti. The article justified the principle of this altitude dial but gave no mathematical proof and although dealt with in Waugh's excellent book (again without proof) many enthusiasts doubted the accuracy claimed for this little dial in the absence of a mathematical justification for the simple graphical layout.

The Capuchin dial is accurate and the following trigonometrical proof confirms the accuracy claimed and also that of the universal version, the dial of Regiomontanus.

For those not familiar with the Capuchin dial here is a brief description of the simple version shown in Figure 1 constructed from a piece of rigid cardboard 15cm x 10cm, a length of thread 30cm long, a small plummet or weight and a tight fitting bead to run on the thread.

The thread runs in a slit in the cardboard which travels the length of the date line FG. When the thread is slid along the narrow slit to the date position for the day, it is pulled taut and the bead is slid along the thread till it is opposite the noon mark on the semi-circle. The free end of the thread has a small plummet attached and this is then allowed to fall free as the card is held vertical. A small door with a perpendicular slit is situated at the top of the card and opposite this a line is drawn (the sun-line) which is parallel with the top of the card. The vertical board is now tilted until the shaft of sunlight passing through the slit is coincident with the sun-line. The plummet holds the thread vertical and the small bead will indicate the time by its position among the hour lines.

Construction: Draw the line ACB parallel to the top of the card (Figure 1) and in the centre of the card draw the line DCE at right angles to ACB. With centre C and any convenient radius form the semicircle AEB on the underside of ACB. Using a protractor centred at C mark off twelve equal divisions of 15 degrees around the semicircle and through the points marked draw lines parallel to EC. These are the hour lines and are numbered from A which is 12 noon down and around to the right 1, 2, 3, 4 etc, the afternoon hours and from 12 along and above ACB 11, 10, 9, 8 etc the morning hours. If required the hours in the semicircle may be further divided in halves and quarters.

Next draw AD forming an angle with AC equal to the latitude of the place, meeting EC at D. Through D draw FG at right angles to AD. FG is the date line. With a protractor lay off from AD 23.5 degrees either side of AD and from A through the points marked draw AF and AG. Where the 23.5 degree angle cuts the date line FG at F this will be 22nd December and at the opposite end G will be 21st June. From an almanac using the second year after a leap year which gives a close approximation of the mean declination of the four year cycle take out the declinations for the first, the tenth and the twentieth of each month. With a protractor mark off the declination angles found along the date line FG, (the 10th and 20th have not been

shown in Figure 1) with the south declinations to the left of AD and the north declination to the right. This of course would be reversed in the southern hemisphere. Jan, Feb, Mar, April and May are inscribed above FG and Nov, Oct, Sept, Aug and July below FG. Now with centre F and radius FA draw the arc AY and with centre G and radius GA draw the arc AZ. The arcs mark the limits of the hour lines and the bead indicating the time will always fall between the two arcs. Lastly draw the sun-line at the top of the card parallel to the line ACB and near the right hand edge draw a small rectangular figure abef and exactly in the centre of the figure and continuous with the sun-line draw cd.

With a Stanley knife cut through the cardboard from F to G, from b to f, from a to e, from e to f and from c to d. Making sure that the fold line ab is not cut and is at right angles to the sun-line fold the rectangle aefb upright ensuring that cd is perpendicular to the sun-line.

Take a piece of thread about 30cm long and tie a large knot at one end. Cut a small round cardboard disc or washer and with a needle make a hole in the middle and pull the thread through the hole. Now push the thread from the back of the card through the date line slit until the cardboard washer engages at the back of the card. Now thread a small bead on the thread of such a size that the bead will grip the thread i.e. stay in the position placed until pulled to change its position and then tie the small plummet or weight to the free end of the thread hanging out in front. The dial is now ready for use.

Early writers describing the Capuchin dial did not use the sun slit and ray of light along the sun-line but instead used two parallel lines the width of the door as a shadow line. The upper edge of the rectangular door formed the prolongation of the shadow. This meant that the card had to be tilted further than necessary for the upper edge to take effect, in fact about a quarter of a degree more than the sun-line. The upper limb of the sun casts the shadow instead of the centre. Even at some distance from noon the sun may take an appreciable time to rise a quarter of a degree and this amount of time is the error found in using the shadow line rather than the sun-line.

To prepare the dial for observation make sure the door is opened and at right angles. Push the thread along the date line slot until it is positioned at the date of the observation then pull the thread taut and slide the bead till it is coincident with the noon mark at A. Holding the card vertical with the right hand edge facing the sun, tilt the card until the shaft of sunlight is superimposed on the sun-line. Read the time from the position of the bead in relation to hour lines.

Like all altitude dials the Capuchin does not differentiate between morning and afternoon but one is normally aware whether the sun is rising or falling to make this decision except when close to noon where it will always be uncertain unless a second reading is taken later.

To demonstrate the accuracy of this little instrument let H (Figure 2) be the position on the date line from which the

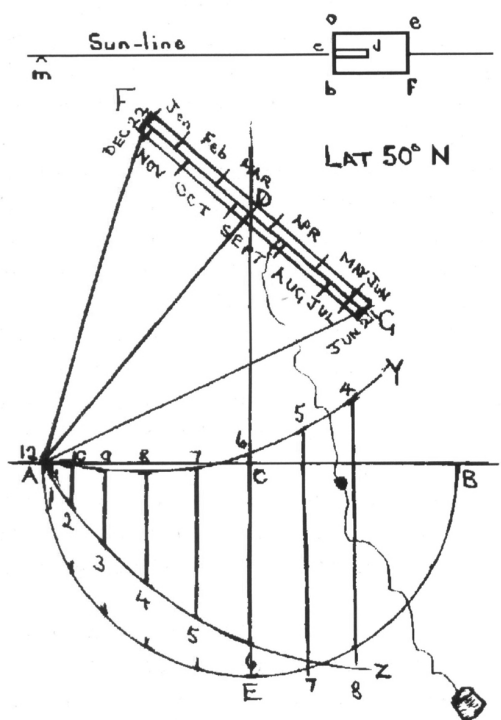

FIGURE 1

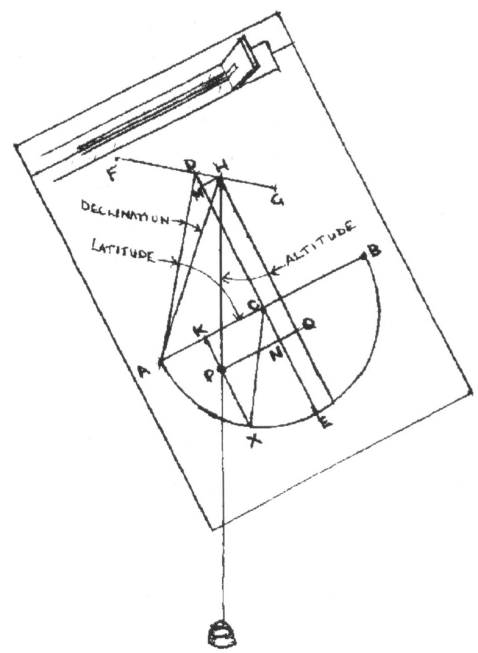

FIGURE 2

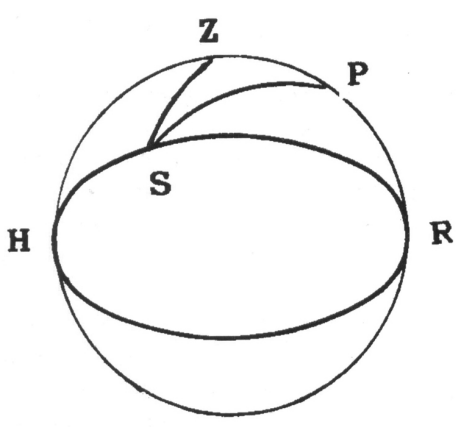

FIGURE 3

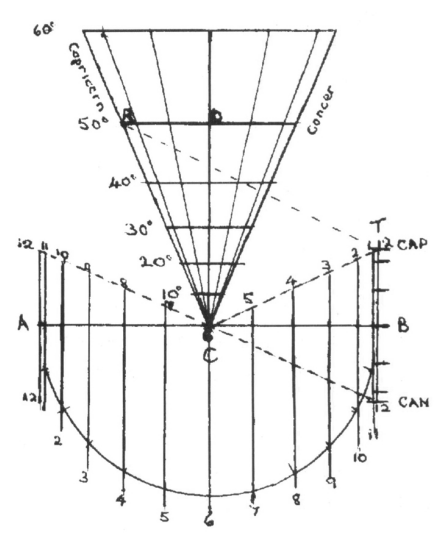

FIGURE 4

plummet is suspended at the time of the observation with DAH the north declination angle of the sun; P the bead sitting opposite the hour line KX. By joining CX we determine the hour angle ACX from noon given by the bead. It is necessary to prove that this hour angle is correct and corresponds to a north latitude DAC, a north declination DAH and an altitude equal to the angle AC (which is parallel with the sun line) makes with the horizontal. The angle PHQ will be equal to the altitude if HQ be drawn parallel to DE, for HQ will then be at right angles to the sun-line and HP at right angles to the horizontal.

Draw PQ and HM parallel to AB so they meet DCE and M and N respectively.

Let the equal radii HA and HP be represented by a. Then it follows from Figure 2:

$$AD = a \cos \text{ decl} \quad DH = a \sin \text{ decl} \quad PQ = a \sin \text{ alt}$$

$$CX = AC = AD \cos \text{ lat} = a \cos \text{ decl} \cos \text{ lat}$$

$$PN = CK = CX \cos ACX = a \cos \text{ decl} \cos \text{ lat} \cos ACX$$

$$NQ = MH = DH \sin MDH = a \sin \text{ decl} \sin \text{ lat}$$

Therefore the angle MDH = DAC = latitude

But because PQ = NQ + PN we have by substitution,
 $a \sin \text{ alt} = a \sin \text{ decl} \sin \text{ lat} + a \cos \text{ decl} \cos \text{ lat} \cos ACX.$

And dividing by a throughout:

$$\sin \text{ alt} = \sin \text{ decl} \sin \text{ lat} + \cos \text{ decl} \cos \text{ lat} \cos ACX \quad \dots (1)$$

The equation which determines the hour angle ACX shown by the bead.

To determine the hour angle of the sun at the same time, let Figure 3 represent the celestial sphere, HR the horizon and P the pole with Z the zenith and S the sun.

From the spherical triangle PZS it may be seen:

$$\cos ZS = \cos PS \cos ZP + \sin PS \sin ZP \cos ZPS$$

But ZS = zenith distance = 90° - altitude

$$ZP = 90^\circ - PR = 90^\circ - \text{latitude}$$

$$PS = \text{polar distance} = 90^\circ - \text{declination}$$

And by substitution:

$$\sin \text{ alt} = \sin \text{ decl} \sin \text{ lat} + \cos \text{ decl} \cos \text{ lat} \cos ZPS \quad \dots (2)$$

and ZPS is the hour angle of the sun.

By comparing the two formulae (1) and (2) it may be seen that the hour angle indicated by the bead will be the same as that given by the sun and justifies the accuracy of the Capuchin dial. The slight error caused by refraction at sunset and sunrise slightly exceeds half a degree. This can be eliminated by placing a small cross at m just below the sun-line at a distance subtended by half a degree from c (Figure 1) and allow the ray of light to fall from c to the cross at m instead of along the sun-line at sunset and sunrise.

Figure 4 shows the design of the Regiomontanus dial which is based on the same principle as the Capuchin dial but modified for use in all latitudes. The latitudes are projected onto the main centre line exactly as for the Capuchin in Figure 1 but are the drawn at right angles to

the centre line. Above the 60° latitude line a swivel arm is mounted (not shown in Figure 4) which allows the thread to be placed over the junction of the cross latitude lines and the date lines. With this position held the thread and bead are then moved to the right and the bead placed over the same date point on the scale at right angles to the central date line. The early models of the Regiomontanus dial were not calibrated in unequal months but in equal zodiacal signs. The distance found on the Capuchin dial in Figure 1 from 50° latitude on 22nd December and the 12 noon point i.e. the distance from F to A is the same distance as that in the Regiomontanus dial from 22nd December at 50° latitude to 22nd December on the date line at right angles i.e. from R to T. The Regiomontanus bead will fall on the same hour line as the Capuchin but at a slightly lower level although the distance subtended by both beads for the same date and latitude are the same.

The following is the proof that the construction in Figure 1 gives the same result as that in Figure 4 (Capuchin dial) AD = AC sec latitude therefore FA = AC sec declination sec latitude.

At any latitude (see Figure 4) the date at that latitude will be at right angles to the same date (declination) at the equivalent declination on the lower right hand date line. Take for example the position at 50° latitude on 22 December i.e. a declination of 23.5° shown by the letter R in Figure 4. The same declination at T forms a right angle.

Also in Figure 4 CB = AC and CD = AC tan latitude

By Pythagorus: $RT^2 = RC^2 + CT^2$

$$\text{and } RC = AC \tan \text{ latitude sec decl}$$

$$\text{and also } CT = CB \sec \text{ declination}$$

$$\text{It follows } RT^2 = CB^2 \sec^2 \text{ decl} + AC^2 \tan^2 \text{ lat sec}^2 \text{ declination}$$

$$RC^2 = CB^2 \sec^2 \text{ decl} (1 + \tan^2 \text{ latitude})$$

$$3 \quad RT^2 = CB^2 \sec^2 \text{ decl sec}^2 \text{ latitude}$$

$$RT = CB \sec \text{ decl sec latitude} \quad (\text{Figure 4})$$

$$\text{And } FA = AC \sec \text{ decl sec latitude} \quad (\text{Figure 1})$$

But as AC = CB Then RT = FA

The construction in Figure 1 gives the same result as that in Figure 4.

It is often claimed Francois de Saint-Rigaud, a Jesuit priest invented the Capuchin dial in 1630. Regiomontanus (1436-76) however was using the principle almost two hundred years earlier. And before that the Navicula another similar altitude dial, not quite so accurate was used in the 13th century. We cannot but admire the sound mathematics of the early astronomers and indeed some regard Regiomontanus as the direct successor to Hipparchus and Ptolemy. He is given credit with making spherical trigonometry a science independent of astronomy.⁴

REFERENCES

1. The Journal of The Royal Astronomical Society of Canada, April 1961. Article by F.A. Stebbins: A Mediaeval Portable Sun-Dial.
2. Encyclopedia Britannic 11th Ed. 1910. Article: Dial & Dialling.
3. My thanks to Dr Roderick Ferguson for checking my calculations and reminding me that trigonometrical identities can be used in geometry.
4. Everyman's Encyclopaedia, vol. 12 page 116.

BIFLAR GNOMONICS

FREDERICK W. SAWERY III

Biflar gnomonics is the study of one of the few truly twentieth-century types of sundials. The biflar sundial was invented in 1922 by Professor Hugo Michnik^{a*}, an Oberlehrer at the Kgl. Gymnasium in Beuthen, Upper Silesia, Germany (now Bytom, Poland). The dial has the advantage of having equiangular hour-lines: the lines all intersect in a single point and the angles between successive hour-lines are uniformly 15° . The usual sort of sundial, based on a gnomonic projection, does not display this uniformity in the placement of the hour-lines. Besides making the dial easier to construct, the equiangular feature permits a very easy daily adjustment of the dial face to give a direct reading of standard clock time rather than local apparent time: once the difference between the two times is determined for a given date and location, the required adjustment amounts to a simple rotation of the dial face through an angle whose size is proportional to that difference. Unlike other horizontal equiangular dials^b, this one does not require an additional daily adjustment of the gnomon; indeed, in the case of the biflar sundial, there is no gnomon to adjust. Instead of the usual shadow-casting device the dial uses two horizontal threads (hence the term 'biflar') suspended at right angles to one another at appropriate heights above the dial face. Although the threads do not intersect, their shadows do; and it is their intersection which indicates the time.

The purpose of the present paper is to elaborate on Michnik's somewhat condensed treatment of the theory of the dial, thus making it more accessible to modern diallers. Besides reproducing Michnik's results and presenting a simplified justification of the construction, we will consider dials on arbitrary planes, a combination of dials which will indicate the time whenever the Sun is above the horizon, and general geometrical procedures for drawing Babylonian, Italian and sidereal hour-lines.

Construction

In order to construct a biflar sundial for a latitude north of the equator, begin with a circle of equiangular hour-lines: hours are marked clockwise around the circle at 15° intervals; each degree corresponds to 4 minutes of time. Suppose perpendicular lines NQS and EQW (figure 1) are drawn

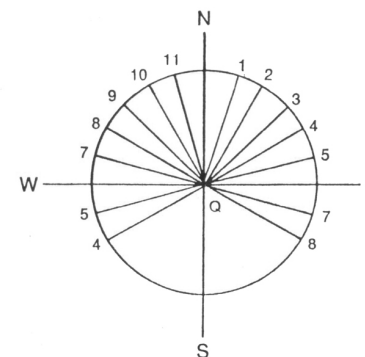

FIGURE 1.

on a horizontal base; the hour-circle should be attached to this base at its centre Q so that it can rotate freely. The line SN will represent the meridian; the direction from Q to N is north. Let O be a point on QN such that the segment QO has unit length. Suspend a thread horizontally above O in the east-west direction with height $\tan \phi$, where ϕ is the geographical latitude at which the dial is to be used. Suspend a second thread horizontally above O in the north-south direction with height $\sec \phi$. To set the dial up, place it on a horizontal surface with the threads in the directions indicated, using true geographic north. Rotate the hour-circle so that the noon-line lies along the meridian QN. The intersection of the threads' shadows on the dial face will register local apparent time. Alternatively, if the hour-line corresponding to the (clock) time at which the Sun crosses the meridian on any given day is made to lie along QN, then the dial will agree with the clock throughout the day.

There are a number of ways to determine the direction of true north, the easiest of which uses the dial itself with an accurate clock. After rotating the dial face to indicate Standard (or Summer) Time, rotate the entire dial base until the correct time is read; the dial will then be correctly oriented and will continue to give correct readings throughout the year with only the minor modifications already noted.

Local noon, the time of the Sun's crossing the meridian for any given day and location, may be determined by reference to the Equation of Time (a table which is available in most almanacs). To determine the Standard Time of local noon, the appropriate entry in the table is to be added algebraically to the base time which is noon plus $4(\lambda - \lambda')$ minutes, where λ is the longitude, expressed in degrees, of the dial's location and λ' is the standard meridian of the dial's time zone. During Summer Time, of course, an additional hour must be added. Alternatively, local noon may be determined simply as the time midway between local sunrise and sunset.

*The letters refer to notes at the end of this paper.

For a dial south of the equator the hours are marked counterclockwise around the circle. The point O should be selected on the southern line segment QS which now corresponds to the noon-line. The heights of the threads above O are the same as they would be for a dial at the corresponding latitude above the equator^c.

Justification

Suppose that the threads on the dial are attached to a vertical rod with base at point O. In figure 2, the shadow of this rod is OR; lines UP (parallel to QE) and RP (parallel to QN) are the shadows of the threads, and P is therefore the intersection of the shadows. We will need the following identities:

$$\cos h \cos A = \sin \phi \cos \delta \cos t - \cos \phi \sin \delta \quad (1)$$

$$\cos h \sin A = \cos \delta \sin t \quad (2)$$

$$\sin h = \sin \phi \sin \delta + \cos \phi \cos \delta \cos t \quad (3)$$

where t = solar hour-angle; A = solar azimuth; h = solar altitude; δ = solar declination.

In order to justify the equiangular construction of the dial described above, we need to establish that the angle w between the meridian line QN and the hour-line QP is equal to the Sun's hour-angle t .

$$OU = \tan \phi \cot h \quad OR = \sec \phi \cot h$$

$$\begin{aligned} \tan w &= PV/QV = RT/(1+OV) \\ &= \sec \phi \cot h \sin A / (1 + \tan \phi \cot h \cos A) \\ &= \cos h \sin A / (\cos \phi \sin h + \sin \phi \cos h \cos A) \\ &= \cos \delta \sin t / (\cos^2 \phi \cos \delta \cos t + \sin^2 \phi \cos \delta \cos t) \\ &= \tan t \end{aligned}$$

Thus, $w = t$ and the equiangular bifilar sundial is justified. The case for a southern dial is similar.

Optimum radius

One drawback of the bifilar sundial is that it does not indicate the hour for the entire time that the Sun is above the horizon; as the Sun rises or sets, the distance QP from the centre to the point of intersection of the shadows becomes larger than the radius of the dial. Referring to figure 2, the distance QP is determined as follows:

$$\begin{aligned} QP &= PV/\sin w = \sec \phi \cot h \sin A \operatorname{cosec} t \\ &= \sec \phi \operatorname{cosec} h \cos \delta \quad \text{by (2)} \\ &= \sec \phi / (\sin \phi \tan \delta + \cos \phi \cos t) \quad \text{by (3)} \end{aligned}$$

Thus the latest hour-angle t_f which can be read on a dial of radius ρ (in units equal to the distance QO) for a given declination δ is determined by setting $QP = \rho$ and solving for t :

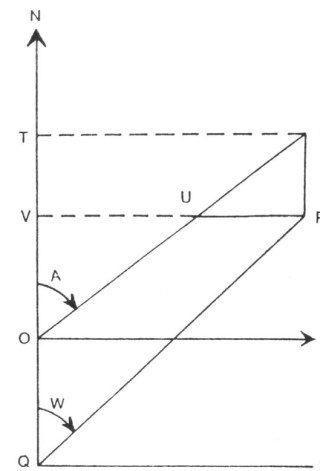

FIGURE 2.

$$t_f = \cos^{-1}[(1 - \rho \cos \phi \sin \phi \tan \delta) / (\rho \cos^2 \phi)] .$$

The hour-angle t_s of sunset for a given day and latitude is

$$t_s = \cos^{-1}[-\tan \phi \tan \delta] .$$

As a guide for the selection of a convenient radius, values for the ratio t_f/t_s of these hour-angles appear in Tables I and II for latitudes 40°N and $51^\circ 30'\text{N}$, respectively. A procedure for constructing a combination of dials which indicates the time whenever the Sun is above the horizon will be discussed below.

TABLE I

VALUES OF THE RATIO t_f/t_s FOR LATITUDE 40°N

Radius	Summer Solstice	Equinox	Winter Solstice
3	0.703	0.615	0.310
4	0.776	0.720	0.551
5	0.820	0.779	0.658
6	0.849	0.817	0.723
7	0.870	0.843	0.766
8	0.886	0.863	0.798
9	0.899	0.879	0.822
10	0.909	0.891	0.840

Dials for arbitrary Planes

Although we have been considering dials which lie on a horizontal plane, it is possible to construct a bifilar dial for any given plane. Suppose

we draw a north-south line N_1QS_1 and an east-west line E_1QW_1 on a horizontal plane and then rotate the plane through an angle i about E_1W_1 so that the line segment QN_1 is above the horizon. Suppose further that the plane is then rotated clockwise about the vertical line QZ (where Z is the zenith point directly overhead) through an angle d . As a result of these rotations the plane is said to have inclination i and declination d . In order to construct a dial on an arbitrary plane the only information needed in addition to the dial's latitude is the inclination and declination of the plane on which it is to rest. Throughout the following, the line QN_1 (figure 3) on a given plane will be understood to be the north ray of the line N_1QS_1 which is obtained in the manner just described: beginning as a horizontal meridian line and then being rotated so that it lies on the given plane.

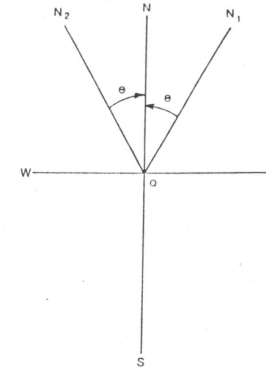

FIGURE 3. (The angle N_2QN should be θ' .)

TABLE II

VALUES OF THE RATIO t_f/t_s FOR LATITUDE $51^\circ 30'N$

Radius	Summer Solstice	Equinox	Winter Solstice
3	0.582	0.341	-
4	0.685	0.554	-
5	0.745	0.655	-
6	0.785	0.717	0.225
7	0.814	0.760	0.421
8	0.836	0.791	0.523
9	0.853	0.815	0.592
10	0.867	0.834	0.642

Now to construct an equiangular bifilar sundial for latitude ϕ on a plane with inclination i and declination d , begin by selecting a point Q on the plane and draw the line segment QN_1 . Draw the perpendicular lines NQS and EQW (figure 3) with the angle θ from QN_1 to QN determined as follows:

$$\cos \theta = \frac{\tan \phi \sin i + \cos d \cos i}{((\tan \phi \sin i + \cos d \cos i)^2 + \sin^2 d)^{1/2}}$$

where the direction from QN_1 to QN is counterclockwise if d is positive and clockwise if d is negative. QN is the intersection of the given plane with the plane determined by its pole and the celestial axis.

Alternatively, the lines NQS and EQW may be determined by first drawing the north-south line QN_2 (figure 3); *i.e.* the line which is the intersection of the given plane and the meridian plane. The angle θ' from QN_2 to QN is determined as follows:

$$\tan \theta' = \frac{\sin \phi \cos i - \cos \phi \sin i \cos d}{\sin \phi \cot d + \cos \phi \cot i \operatorname{cosec} d}$$

Now at latitude ϕ and longitude λ a plane with inclination i and declination d is parallel to a horizontal plane at latitude α and longitude $(\lambda + t')$, where longitude is understood to increase to the west, and

$$\sin \alpha = \sin \phi \cos i - \cos \phi \sin i \cos d \quad (4)$$

$$\sin t' = \sin i \sin d \sec \alpha$$

$$\cot t' = \sin \phi \cot d + \cos \phi \cot i \operatorname{cosec} d \quad (5)$$

Moreover, if north-south and east-west lines were drawn on that horizontal plane, they would be parallel respectively to the lines NS and EW which have already been drawn on the given plane. We can therefore simply construct the dial over these lines as before, but in doing so we must use α as our latitude as though the plane were displaced to the location in which it would be horizontal.

The dial is now complete, but it is important to note that the point N (or, if $\alpha < 0^\circ$, the point S) no longer corresponds to local noon but rather to the hour-angle t' (*i.e.* the time past noon expressed in degrees, where 1° equals 4 minutes of time).

As examples, suppose first that we wish to construct at latitude $40^\circ N$ a vertical sundial which faces directly south. For such a dial we have $i = 90^\circ$ and $d = \theta = \theta' = 0^\circ$; the line NS is vertical. Further calculation yields $\alpha = -50^\circ$ and $t' = 0^\circ$. The dial to be constructed may thus be treated as though it were a horizontal dial at latitude $50^\circ S$.

Since the distance from the shadows' intersection to the centre of the horizontal dial is generally greater when the Sun is low above the horizon, a vertical dial used at a northern latitude will be easier to read during the spring and summer than will a horizontal one: during these seasons the Sun is low in the sky at the southern latitude whose horizontal plane is parallel to the vertical dial. However, although such a dial would be

TABLE III

USABLE PERIOD OF DIALS WITH RADIUS 2.95 AT LATITUDE 40°N

	<i>East</i>	<i>Horizontal</i>	<i>West</i>
Summer Solstice	4:35–10:41	6:49–5:11	1:19–7:25
Equinoxes	6:00–10:41	8:21–3:39	1:19–6:00
Winter Solstice	7:25–10:41	10:41–1:19	1:19–4:35

easier to read, it would indicate time during a smaller portion of the daylight.

Now suppose that at latitude 40°N we want a vertical dial facing directly east, so that $i = 90^\circ$, $d = -90^\circ$ and $\theta = +50^\circ$, where the positive value for θ indicates a clockwise measurement from QN_1 to QN . The line QN_1 is again vertical, so QN is parallel to the celestial axis. Since $\alpha = 0^\circ$, the dial may be constructed as though it were in either hemisphere, the different choices determining the placement of the point O and whether the hours are marked in a clockwise or counterclockwise sense. Because $i' = -90^\circ$, the line QN (or QS , depending on the placement of O) is now the hour-line for 6 am local apparent time. The resulting dial is equivalent to the classical vertical direct east dial.

Direct east and west dials may obviously be used to read early morning and late afternoon hours, respectively. A combination of these dials with a horizontal one, all of them being displayed, for example, on the faces of a cube, will indicate the time whenever the Sun is above the horizon, provided their radii are chosen appropriately. Thus, if all three dials have the radius 2.95 (where the line QO has unit length) at latitude 40°N, the time during which each dial is usable is given in Table III for selected dates.

The equations for determining appropriate values for the radius ρ are complex. On the simplifying assumption that the dials share a common radius and are either horizontal or vertical, the value chosen for ρ must be such that conditions (6) and (7) hold, where $\epsilon = 23;26^\circ$.

$$\cos^{-1} [(1 + |\rho \cos \phi \sin \phi \tan \epsilon|)/(\rho \cos^2 \phi)] + \cos^{-1} [1/\rho] \geq 90^\circ \quad (6)$$

$$\cos^{-1} [-|\tan \phi| \tan \delta] - \cos^{-1} [1/\rho] \leq 90^\circ \quad (7)$$

The first condition guarantees that the dial combination records the time whenever the Sun is above the horizon between 6 am and 6 pm; the second imposes a similar guarantee for earlier risings and later settings of the Sun. It can be shown that whenever condition (6) is satisfied, so is condition (7). Thus the minimum—and, from the point of view of readability, the best—value for ρ at latitude ϕ is obtained by considering the case of equality in (6) and solving for ρ . This yields the following equation:

$$\rho = K + \sqrt{K^2 + (\sec^2 \phi + \cos^2 \phi)/(1 - \sin^2 \phi \sec^2 \epsilon)}$$

where $K = |\tan \phi \tan \epsilon|/(1 - \sin^2 \phi \sec^2 \epsilon)$.

At latitude 40°N, this equation gives the value $\rho = 2.95$; at latitude 51° 30' N we have $\rho = 5.86$. Additional values for various latitudes are given in Table IV.

Throughout the following, the equations to be given apply to horizontal dials; however, appropriate adjustments may be made to adapt them to dials on arbitrary planes.

TABLE IV

OPTIMUM RADII FOR BIFILAR CUBE DIALS

ϕ	ρ	ϕ	ρ	ϕ	ρ
30°	2.11	40°	2.95	50°	5.21
31°	2.17	41°	3.08	51°	5.63
32°	2.23	42°	3.23	52°	6.11
33°	2.30	43°	3.39	53°	6.68
34°	2.37	44°	3.57	54°	7.35
35°	2.45	45°	3.77	55°	8.14
36°	2.53	46°	3.99	56°	9.11
37°	2.62	47°	4.24	57°	10.29
38°	2.72	48°	4.52	58°	11.77
39°	2.83	49°	4.84	59°	13.67

General theory

The justification given earlier for equiangular bifilar sundials presupposed that the heights of the two threads were known. The general development to be given here makes no such supposition and, as a result, it will demonstrate not only that the values already given are the only ones which produce an equiangular dial, but also that a variety of different (non-equiangular) dials may be obtained by appropriate changes in the heights.

Consider a rectangular co-ordinate system with origin at point O and such that the x and y -axes are directed east and north, respectively (see figure 2). Suppose that horizontal threads are suspended above O , one along the y -axis at height g_1 and the other along the x -axis at height g_2 . As before, suppose that a solid vertical rod has its base at O ; then P is the intersection of the shadows of the threads, and

$$\overline{O\bar{U}} = g_2 \cot h \quad \overline{O\bar{R}} = g_1 \cot h$$

The co-ordinates of P are

$$x = g_1 \cot h \sin A \quad (8)$$

$$y = g_2 \cot h \cos A \quad (9)$$

Using the identities (1)–(3) above, these equations may be transformed into the following:

$$x = g_1 \sin t / (\sin \phi \tan \delta + \cos \phi \cos t) \quad (10)$$

$$y = g_2 (\sin \phi \cos t - \cos \phi \tan \delta) / (\sin \phi \tan \delta + \cos \phi \cos t) \quad (11)$$

Solving these equations for $\tan \delta$ and then eliminating this parameter yields an equation for the hour-lines^d, dependent only on ϕ and t :

$$g_2 x \cot t - g_1 y \sin \phi = g_1 g_2 \cos \phi$$

Since this equation is linear in x and y , the sundial has straight hour-lines. All of these lines intersect in one point Q, the y -intercept (obtained by setting $x = 0$).

$$\begin{aligned} x = 0 &\rightarrow y = -g_2 \cot \phi & \overline{QO} &= g_2 \cot \phi \\ y = 0 &\rightarrow x = g_1 \cos \phi \tan t & \overline{OV} &= g_1 \cos \phi \tan t \end{aligned}$$

Suppose we choose our unit length so that $\overline{QO} = 1$; then $g_2 = \tan \phi$.

We also have $\tan w = \overline{OV}/\overline{QO} = k \tan t$, where $k = g_1 \cos \phi$. In order to obtain an equiangular dial ($w = t$) we must set $k = 1$; we then have $g_1 = \sec \phi$.

However, suppose now that we relinquish the equiangular requirement. Then a variety of dials may be constructed corresponding to different values for k . As an example, suppose we have a usual sort of horizontal (hour-arc) dial constructed for latitude ϕ' . If we identify the meridian line of this dial with QON and the centre of its hour-lines with the point Q, then any text on gnomonics will tell us that

$$\tan w' = \sin \phi' \tan t$$

We can therefore adapt the dial for latitude ϕ and still keep it horizontal by removing the gnomon and erecting a horizontal east-west thread above point O at height $\tan \phi$ and a similar north-south thread at height $\sin \phi' / \cos \phi$; that is, simply set $k = \sin \phi$. If $\phi = \phi'$, then $g_1 = g_2$ and we have an ordinary horizontal dial.

Day curves

On many sundials there are curves drawn to trace the path of the shadow of a particular point on the gnomon for selected dates. While this practice would serve no purpose in an equiangular bifilar sundial with a rotating dial face (unless of course the face were transparent and the curves were drawn on the non-rotating base), nevertheless one may determine exactly what these curves will be in general. The curve we will consider is traced by the intersection of the threads' shadows.

From equation (11) we have

$$\cos t = \tan \delta (g_2 \cos \phi + y \sin \phi) / (g_2 \sin \phi - y \cos \phi)$$

Using this result in equation (10) yields

$$\sin t = g_2 x \tan \delta / (g_1 g_2 \sin \phi - g_1 y \cos \phi)$$

Since $\sin^2 t + \cos^2 t = 1$, we have

$$\tan^2 \delta (g_2^2 x^2 + g_1^2 (g_2 \cos \phi + y \sin \phi)^2) = g_1^2 (g_2 \sin \phi - y \cos \phi)^2$$

Finally, by means of the identity $\cos^2 \phi = 1 - \sin^2 \phi$, we have the following equation of the day curve^e, dependent only on ϕ and δ ,

$$\sin^2 \delta (g_2^2 x^2 + g_1^2 y^2 + g_1^2 g_2^2) = g_1^2 (g_2 \sin \phi - y \cos \phi)^2$$

Note, however, that this equation is based on considering O as the origin. If Q, the centre of the equiangular dial, were used as the origin, the variable y would have to be replaced by $(y - g_2 \cot \phi)$.

On the equinoxes, when $\delta = 0^\circ$, the day curve becomes a straight line from west to east. More generally, the form of the curve on any given day may be determined from Table V.

For a horizontal equiangular dial (constructed say for a northern latitude), it is probably easier to trace the day curves by using polar co-ordinates with Q as origin, since at any time t the point P has the polar co-ordinates (t, \overline{QP}) .

TABLE V

THE FORM OF THE DAY CURVE ON SELECTED DATES

Solar Declination	Day Curve
$\delta > 90 - \phi$	ellipse
$\delta = 90 - \phi$	parabola
$\delta < 90 - \phi$	hyperbola

Altitude and azimuth curves

In addition to day curves, a dial may be furnished with curves of equal solar altitude or azimuth. Thus, for example, on a bifilar sundial with curves for altitude $h = 30^\circ$ or azimuth $A = 40^\circ$, the intersection of the shadows will lie on one of these curves exactly when the Sun has altitude 30° or azimuth 40° , respectively.

The equation for altitude curves is obtained by eliminating the parameter A from equations (8) and (9) to obtain

$$(x \tan h / g_1)^2 + (y \tan h / g_2)^2 = 1$$

The resulting curve is an ellipse.

Using equations (8) and (9) again, but this time eliminating the parameter h , we have

$$y = (g_2 / g_1) x \cot A$$

The azimuth curve is thus a straight line through the origin O. The line corresponding to solar azimuth A itself has an azimuth A' , where $\cot A'$ is the slope (y/x) of the line. For an equiangular dial the two angles are therefore related to each other as follows:

$$\cot A' = \sin \phi \cot A$$

Babylonian and Italian hour-lines

As a general rule in gnomonics, the zero-point for determining the hour-angle of the Sun for any particular location is local noon, when the Sun is on the meridian. However, this need not be the case; we will consider here two other well-known systems: the Babylonian, which reckons time from the preceding sunrise, and the Italian, which reckons time from the preceding sunset. Consider a sundial which has both Babylonian and Italian hour-lines but on which the Italian lines are numbered in reverse, so that sunset is 0 hours, while one hour before sunset is 1 hour. Such a dial may be used to determine at any given time how many hours have elapsed since sunrise (the Babylonian hour b), how many hours remain until sunset (the reversed Italian hour i), how many hours of daylight there are on the given day ($b+i$), and the local apparent time $\frac{1}{2}(b-i)$, where a zero value for t denotes local noon.

If we let T be the time from sunrise to noon on any given day and let b be the Babylonian hour, then

$$t = b - T \quad \text{and} \quad \cos T = -\tan \phi \tan \delta .$$

Substituting these equations into the equations (10) and (11) for the co-ordinates of the point P yields:

$$x = \frac{g_1 (\sin b - \cos b \tan T)}{(\cos \phi \cos b + \cos \phi \sin b \tan T - \cos \phi)}$$

$$y = \frac{g_2 (\sin \phi \cos b + \sin \phi \sin b \tan T + \cos \phi \cot \phi)}{(\cos \phi \cos b + \cos \phi \sin b \tan T - \cos \phi)}$$

Solving these equations for, and then eliminating, $\tan T$ results in the equation for Babylonian hour-lines:

$$g_1 y \sin \phi \cos \phi (1 - \cos b) - g_2 x \sin b \cos \phi = g_1 g_2 (\sin^2 \phi + \cos^2 \phi \cos b) \quad (12)$$

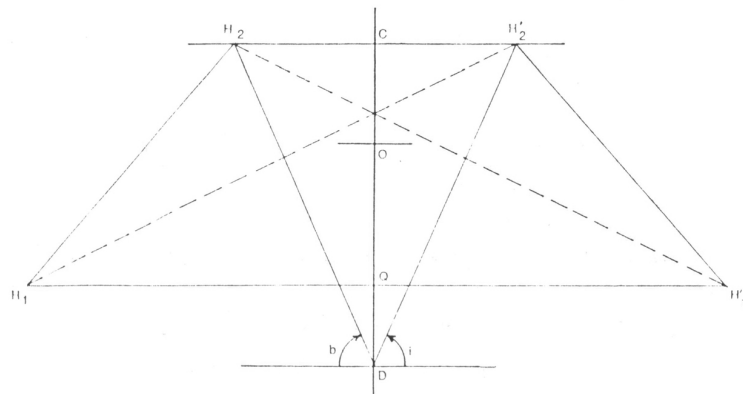

FIGURE 4.

TABLE VI

CO-ORDINATES OF SELECTED POINTS FOR THE CONSTRUCTION OF BABYLONIAN AND ITALIAN HOUR-LINES

Point	General Case		Special Case	
	X	Y	X	Y
Q	0	$-g_2 \cot \phi$	0	-1
C	0	$g_2 \tan \phi$	0	$\tan^2 \phi$
D	0	$g_2 \tan \phi - g_1 \sec \phi$	0	-1

By similar reasoning for the (reverse-numbered) Italian hours i : T may also be viewed as the time from noon to sunset; so $t = T - i$ and the resulting equation is:

$$g_1 y \sin \phi \cos \phi (1 - \cos i) + g_2 x \sin i \cos \phi = g_1 g_2 (\sin^2 \phi + \cos^2 \phi \cos i) \quad (13)$$

Both families of hour-lines are linear; however, neither the Babylonian nor the Italian hour-lines have a common point of intersection, as is the case for the usual astronomical hour-lines. The angles β and ι that they respectively make with the line QON are as follows:

$$\tan \beta = (g_1/g_2) \sin \phi \tan \frac{1}{2}b \quad \tan \iota = -(g_1/g_2) \sin \phi \tan \frac{1}{2}i$$

Thus, if $g_2 = g_1 \sin \phi$, the hour-lines are equiangular in the sense that β and ι are proportional to b and i , respectively.

Michnik gives a graphic means of drawing these hour-lines for special values of g_1 and g_2 ; it may be generalized as follows. In figure 4 let O be the origin as before. Table VI lists the co-ordinates of the points Q, C and D in the general case and in the special case in which $g_2 = \tan \phi$ and $g_1 = \sec \phi$. Construct lines CH_2 and QH_1 perpendicular to QC and let H_2 be the point of intersection of line DH_2 with line CH_2 , where the angle $CDH_2 = b - 90^\circ$. Let point H_1 be such that $\overline{QH_1} = \overline{DH_2}$. The Babylonian hour-line for hour b is H_1H_2 .

A similar construction, symmetric about the line QC and yielding points H_1' and H_2' works for Italian hour-lines.

To justify these constructions it suffices to show that points H_1 and H_2 as well as the symmetrically placed points H_1' and H_2' lie on the respective hour-lines. From the manner of selecting the points we have:

$$H_1 = (-g_1 \sec \phi \operatorname{cosec} b, -g_2 \cot \phi)$$

$$H_2 = (-g_1 \sec \phi \cot b, g_2 \tan \phi)$$

$$H_1' = (g_1 \sec \phi \operatorname{cosec} i, -g_2 \cot \phi)$$

$$H_2' = (g_1 \sec \phi \cot i, g_2 \tan \phi)$$

It is now a simple matter to verify that the co-ordinates of these points satisfy the equations (12) and (13) for the appropriate hour-lines.

It should also be noted that each of the four hour-lines obtainable from these points may be viewed as either Babylonian or Italian (see

Table VII). Although there are no lines corresponding to sunrise ($b = 0^\circ$) or to sunset ($i = 0^\circ$), the same line, given by the following equation, represents the twelfth hours after sunrise and before sunset:

$$y = g_2 (\tan \phi - \cot \phi) / 2$$

Figure 5 displays Babylonian hour-lines, numbered clockwise, and Italian hour-lines, numbered counterclockwise, for a bifilar dial at latitude 40°N with $g_1 = \sec \phi$ and $g_2 = \tan \phi$.

TABLE VII

HOURLINES OBTAINABLE FROM A SINGLE CONSTRUCTION

Line	Babylonian Hour	Italian Hour
H_1H_2	b	$360^\circ - b$
$H_1H'_2$	$180^\circ - b$	$180^\circ + b$
H'_1H_2	$180^\circ + b$	$180^\circ - b$
$H'_1H'_2$	$360^\circ - b$	b

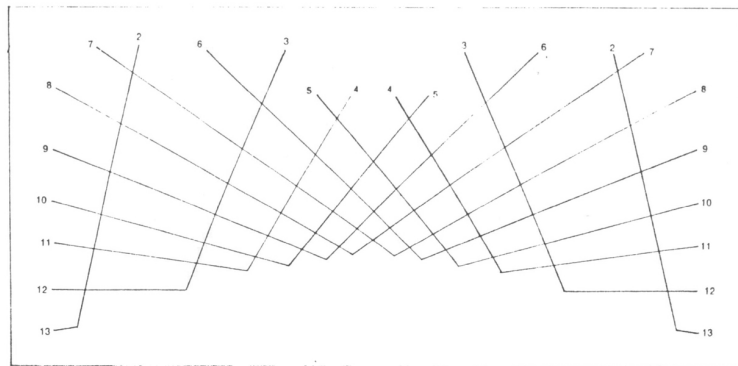

FIGURE 5. Babylonian and Italian hour-lines for $\phi = 40^\circ\text{N}$.

Sidereal hour-lines

Finally^f, we will consider one more system of indicating time: sidereal hours. It is a fact well known to diallers that the length of the solar day, defined as the time between successive meridian-crossings by the Sun, is not constant. Because the Sun appears to have a non-uniform motion of its own along the ecliptic with respect to the fixed stars, the so-called Equation of Time must be added to the sundial's reading to obtain a result which increases uniformly. The chief advantage of an equiangular dial is that it affords an easy means of making the desired correction in the reading.

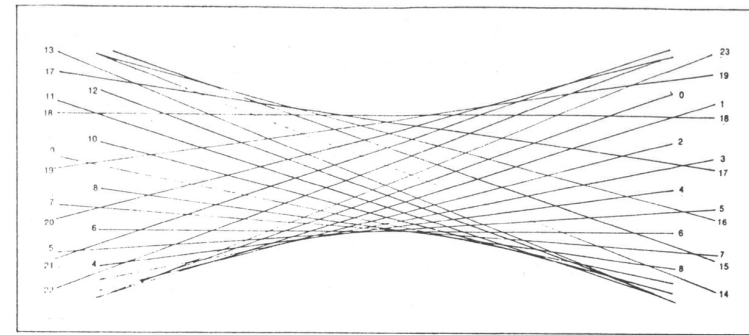

FIGURE 6. Sidereal hour-lines for $\phi = 40^\circ\text{N}$.

Suppose, however, that the day is now defined as the interval between successive crossings of the meridian by a fixed point on the ecliptic—in particular, by the vernal point, *i.e.* the Sun's position on the day of the vernal equinox, which corresponds to the intersection of the ecliptic and celestial equator. This so-called sidereal day is of interest primarily in astronomical contexts; its length is constant and, on the average, is approximately 3 minutes 56 seconds shorter than a solar day. By definition, the local sidereal hour θ is the hour-angle of the vernal point. For any astronomical body, and in particular for the Sun, θ is equal to the body's hour-angle t (the angle west of the meridian measured along the equator) plus its right ascension α (the angle east of the vernal point measured along the equator).

To obtain an equation for sidereal hour-lines we begin with the equations relating θ to the Sun's hour-angle, right ascension and declination.

$$t = \theta - \alpha \quad \tan \delta = \tan \epsilon \sin \alpha \quad (\epsilon = 23;26')$$

At this point, we proceed as before; using these equations for substitutions in (10) and (11), we obtain:

$$x = \frac{g_1 (\sin \theta - \cos \theta \tan \alpha)}{(\sin \phi \tan \epsilon + \cos \phi \sin \theta) \tan \alpha + \cos \phi \cos \theta}$$

$$y = \frac{g_2 ((\sin \phi \sin \theta - \cos \phi \tan \epsilon) \tan \alpha + \sin \phi \cos \theta)}{(\sin \phi \tan \epsilon + \cos \phi \sin \theta) \tan \alpha + \cos \phi \cos \theta}$$

Eliminating $\tan \alpha$ yields the equation for the sidereal hour-lines:

$$g_2 x \cos \theta \tan \epsilon - g_1 y (\cos \phi + \sin \phi \sin \theta \tan \epsilon) = g_1 g_2 (\cos \phi \sin \theta \tan \epsilon - \sin \phi) \quad (14)$$

The equation^g is linear in x and y ; in the special case of $\phi = 90^\circ - \epsilon$, these lines coincide with the Babylonian (for $\theta = b - 90^\circ$) and Italian (for

$\theta = 270^\circ - i$) hour-lines. Sidereal hour-lines for latitude 40°N under the assumptions $g_1 = \sec \phi$ and $g_2 = \tan \phi$ are drawn in figure 6.

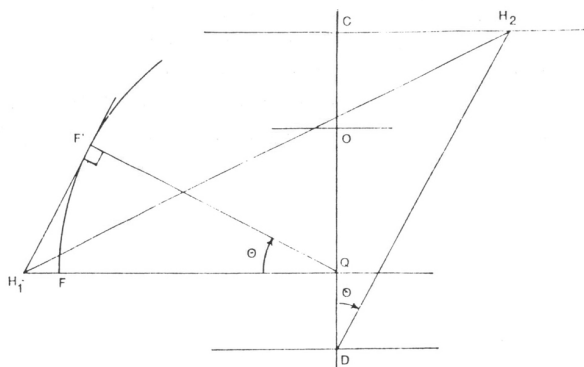

FIGURE 7.

A graphic construction of these lines similar to the one given for Babylonian hour-lines may be developed as follows^h. In figure 7 let O be the origin and let points Q, C, D and F have the co-ordinates listed in Table VIII, where the special case is the one which generates figure 6. Construct lines CH_2 and QF perpendicular to QC . Let H_2 be the intersection of lines CH_2 and DH_2 , where the angle $CDH_2 = \theta$. Let H_1 be the intersection of the line QF with the tangent to the circle (with centre Q and radius QF) at point F' , where the angle $QFQ' = \theta$. The sidereal hour-line for hour θ is H_1H_2 . For the limiting cases when these points are at infinity, the hour-lines have the following equations:

$$\begin{aligned} \theta = 90^\circ &\rightarrow y = g_2 \tan(\phi - \epsilon) \\ \theta = 270^\circ &\rightarrow y = g_2 \tan(\phi + \epsilon) \end{aligned}$$

TABLE VIII

CO-ORDINATES OF SELECTED POINTS FOR THE CONSTRUCTION OF SIDEREAL HOUR-LINES

Point	General Case		Special Case	
	X	Y	X	Y
Q	0	$-g_2 \cot \phi$	0	-1
C	0	$g_2 \tan \phi$	0	$\tan^2 \phi$
D	0	$g_2 \tan \phi - g_1 \sec \phi$	0	-1
F	$-g_1 \operatorname{cosec} \phi \cot \epsilon$	$-g_2 \cot \phi$	$-\sec \phi \operatorname{cosec} \phi \cot \epsilon$	-1

To justify the construction, it suffices to determine that the points H_1 and H_2 satisfy equation (14).

$$\begin{aligned} H_1 &= (-g_1 \operatorname{cosec} \phi \sec \theta \cot \epsilon, -g_2 \cot \phi) \\ H_2 &= (g_1 \sec \phi \tan \theta, g_2 \tan \phi) \end{aligned}$$

TABLE IX

HOURLINES OBTAINABLE FROM A SINGLE CONSTRUCTION

Line	Sidereal Hour
H_1H_2	θ
$H_1'H_2'$	$360^\circ - \theta$
$H_1''H_2''$	$180^\circ + \theta$
$H_1'''H_2'''$	$180^\circ - \theta$

If we consider the points H_1' and H_2' as before, we see that each construction actually gives us four hour-lines (see Table IX).

Perhaps the primary interest of these hour-lines is that they demonstrate that a sundial is capable of recording time uniformly despite the fact that the apparent position of the Sun changes non-uniformlyⁱ. No correction needs to be made to the dial reading to obtain sidereal time. The value of θ at local noon on the vernal equinox is 0° ; it continues to increase throughout the succeeding year, having a value of 90° on the summer solstice, 180° on the autumn equinox and 270° on the winter solstice.

Notes

- See ref. 10. Other references to bifilar dials include 1 (p. 105) and 2 (p. 135). Another brief geometrical treatment (ref. 5) of the basic equiangular dial appeared while the present article was in the hands of the referee.
- Dials of this type are discussed in ref. 11, where the treatment is not restricted to horizontal examples. This type of dial was invented in the seventeenth-century by Samuel Foster³ but is often attributed to the eighteenth-century mathematician and philosopher J. H. Lambert⁷. The dial is discussed in ref. 1, and there have been a number of more recent studies of it, the most extensive being refs 4, 6 and 11.
- As a practical addition to the dial, one should consider some form of alidade or pointer free to rotate as a diameter of the dial face. If a line is drawn down the middle of the alidade, it can be turned until the intersection of the shadows lies on the line and the end of the alidade indicates the time on the circumference of the dial face. This addition would eliminate the need for drawing an excessive number of hour-lines. It should be noted that the heights of the threads must be measured from the upper surface of the alidade rather than from the surface of the dial proper.
Another practical point to make here is that if the threads are attached to the tops of their supports, the shadows of the supports will not obliterate any readings. However, if the supports extend above the threads, care should be taken to insure against problems caused by the shadows.
- The astronomical hour-lines for a dial at latitude ϕ with inclination i and declination d are given by the equation
$$g_1 g_2 \cos a = g_2 \cot(t - t') - g_1 y \sin a$$
where a and t' are given by equations (4) and (5).

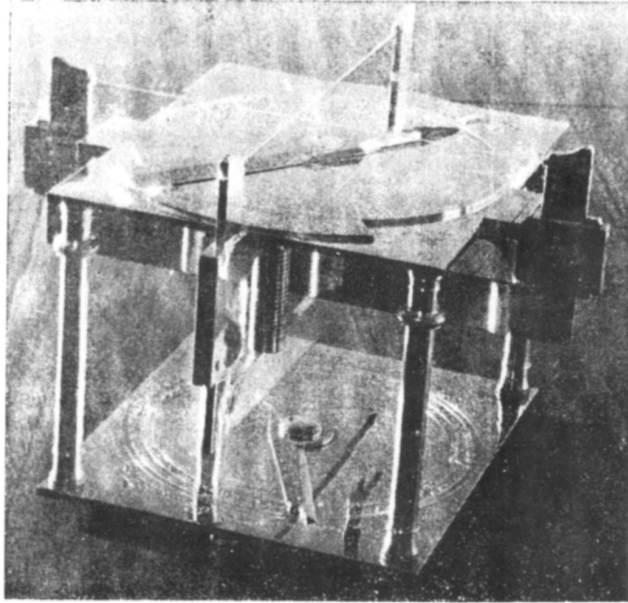

FIGURE 8. An equiangular bifilar sundial designed by M. U. Zakariya and the author. The dial is on the upper plate with hours marked around the circumference. The alidade has a line down its centre and must be turned until the intersection of the shadows of the threads lies on that line. The height and position of the threads are adjusted by micrometers on the underside of the plate, according to the latitude of the dial's location; adjustments for longitude and the equation of time are made with verniers on the dial face. The lower plate gives the equation of time. This dial is the first of a small series of bifilar dials to be constructed by Mr Zakariya.

(e) The day curve for a non-horizontal dial is

$$\sin^2 \delta (g_2^2 x^2 + g_1^2 y^2 + g_1^2 g_2^2) = g_1^2 (g_2 \sin \alpha - y \cos \alpha)^2$$

where α is given by equation (4).

(f) Michnik also considers temporary or unequal hour-lines, which result from dividing the period of daylight on any given day into 12 equal hours. The lines are given by higher-order algebraic equations (although they are often approximated by straight lines) and will not be considered here. They are treated in detail for the case of non-bifilar dials in ref. 8; the modification required to adapt them to the bifilar case is discussed in ref. 10.

(g) The equation for sidereal hour-lines for non-horizontal dials is

$$g_2 x \cos (\theta - t') \tan \epsilon - g_1 y (\cos \alpha + \sin \alpha \sin (\theta - t') \tan \epsilon) = g_1 g_2 (\cos \alpha \sin (\theta - t') \tan \epsilon - \sin \alpha)$$

where α and t' are given by equations (4) and (5).

- (h) For a somewhat different construction and development of sidereal hour-lines for non-bifilar sundials, see ref. 9.
- (i) For the use to which such a sundial may be put in astrology, see ref. 1 (chapter XIV).

References

- 1 Drecker, J., *Die Theorie der Sonnenuhren*, Berlin, 1925.
- 2 Drecker, J., *Zeitmessung und Sterneutung in geschichtlicher Darstellung*, Berlin, 1925.
- 3 Foster, S., *Elliptical, or azimuthal horologigraphy*, London, 1654.
- 4 Hanke, W., *Die Sterne*, **51**, 159 (1975).
- 5 Hanke, W., *Die Sterne*, **52**, 228 (1976).
- 6 Janin, L., *Le Cadran Solaire Analemattique—Histoire et Développements*. Note 74.2057. Besançon, France: Centre Technique de l'Industrie Horlogère, 1974.
- 7 Lambert, J., *Berliner Astronomisches Jahrbuch für 1777*, 200. Berlin, 1775.
- 8 Michnik, H., *Beiträge zur Theorie der Sonnenuhren*. Leipzig, 1914.
- 9 Michnik, H., *Astronomische Nachrichten*, **216**, 441 (1922).
- 10 Michnik, H., *Astronomische Nachrichten*, **217**, 81 (1923).
- 11 Taylor, G., *J. Br. astron. Assoc.*, **86**, 7 (1975).

See Appendix to this article on next page.

* * * * *

SOME EARLY DIALLING TITLE PAGES AND ILLUSTRATIONS

JOHN BRIGGS

For many years Senor José Luis Basanta has sent out cards to his friends to wish them well for the coming New Year. These bear the title pages of early dialling works and manuscripts in his own library and are from many different countries. These title pages are of great interest and will not have been seen by the majority of BSS members, so the writer asked Senor Basanta for permission to reproduce these in the BSS Bulletin, to which he has very kindly consented. The first two are from P.M.E. Erwood, the bookseller.

1. Johannes Hamman. Woodcut illustration from Regiomontanus, *Epitoma in Almagestum Ptolemaei*, published 31st August 1496 by Johannes Hamman. Around the border is **ALTIOR INCVBVIT ANIMUS SVBIMAGINE MVNDI**, and in the bottom border is **PTOLEMEVS** and **IOHANES DE MONTER**. This identifies the figure on the left as Ptolemy, that on the right as Johannes de Monter.

The words on the diagram are: **Circulus Arcticus** - Arctic Circle, **Polus Zodiac** - Northern Zodiac, **Tropicus Cancer** - Tropic of Cancer, **Zodiacus** - Zodiac, **Equinoctialis** - Equinoctial, **Tropicus Capricorn** - Capricorn of Capricorn, **Polus Mundi Antarcticus** - Antarctic World Pole.

The *Almagest*, Ptolemy's great work on astronomy, placed the earth at the centre of the universe, and set back the course of astronomy until Copernicus almost 1400 years later correctly stated that the earth revolved around the sun. Hamman's work was an abridgement of Ptolemy's *Almagest*.

Regiomontanus was the Archbishop of Ratisbon, a German mathematician and an astronomer. He was born in Königsberg in 1436, studied in Italy, and in 1461 travelled with Cardinal Bessarion to Italy to study the Greek language. In 1471 he settled in Nuremberg where he found a patron, Bernard Walther. These two worked on clarifying the Alfonsine Tables, from which the Ephemerides for 1475-1506 resulted, and of which Columbus made much use of in his voyages. Regiomontanus was summoned to Rome in 1464 by Pope Sixtus to help in the reform of the calendar, and whilst engaged on this task he died in Rome in 1476, still a young man. He may have died of a fever, or perhaps was poisoned.

Johannes or Joannis Regiomontanus is the pseudonym for Johann Müller. He published many writings on the torquetum, the armillary astrolabe, the great Ptolemaic rules, the astronomical staff and observations on comets.

2. Hyginus, 1512. Woodcut title page from Hyginus *Astronomi De Mundi et Sphaeraeac Utriusque cum Planetis et variis Signis Historiatis*, published 1512. Astronomy of the World and Sphere with the Planets and various Historical Signs. The arc above the figure (Ptolemy?) in a firmament of stars shows the signs of the Zodiac from Aquarius on the left with a youthful moon, at Capricorn on the right with a rather older sun. The zodiac band on the sphere is a trifle misplaced, the instrument on the right is nondescript but perhaps is intended for altitude measurements only, the figure on the left appears to be *Astronomia*, with an open book on geometry. Latin text.

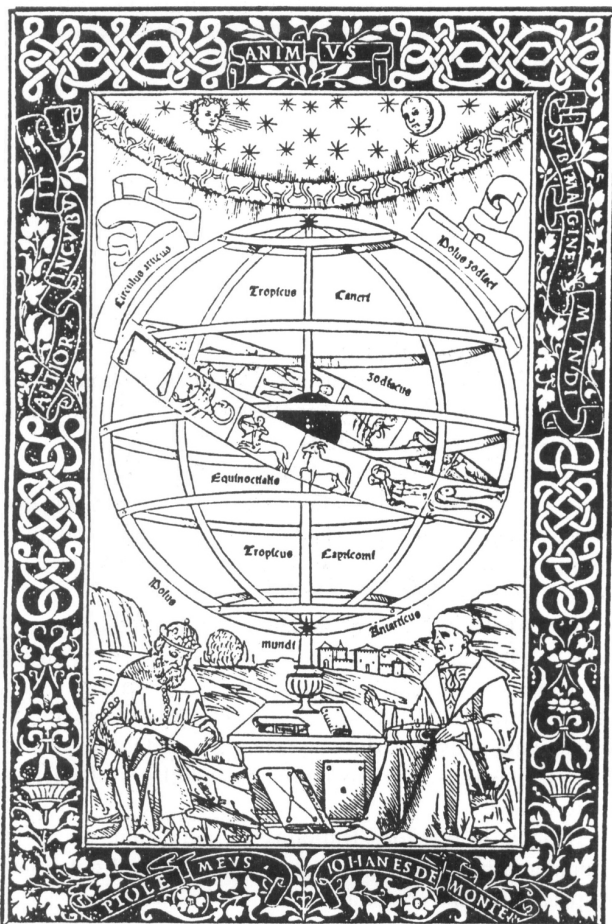

FIGURE 1: Johannes Hamman, Venice, 1496

Clarissimi Hyginij Astronomi De Mundi Et Sphaere Ac Utriusq; Partium Declaratione Cu Planetis Et Varijs Signis Historiatis.



FIGURE 2: Hyginus, Venice, 1512

LIBRO DE RELOGES

S O L A R E S

COMPUESTO POR PEDRO ROIZ

Clerigo Valenciano, discipulo del Maestro Hieronymo Muñoz
en el qual muestra a hazer relojes, en llano, y en paredes
a qualquier viento descubiertas, leuantadas a plo-
mo, o inclinadas bazia tierra, y otras
cosas para esto neccessarias.

DIRIGIDO AL MVY ILLVSTRE SENOR DON

Ioan de Borja, hijo del Illustrissimo y Reuerendissimo Señor
Don Pedro Luys Galceran de Borja, Maestre de
Montesa, y Marques de Nauarres.

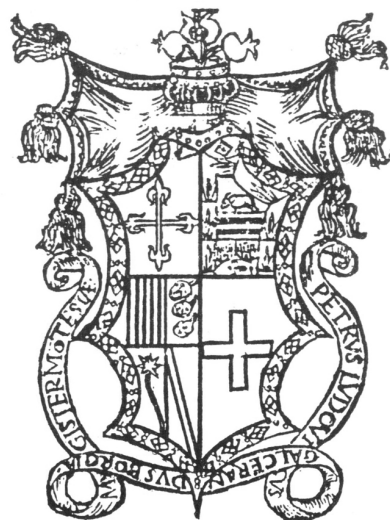

CON LICENCIA

Impresso en Valencia en casa de Pedro de Huete. Año de 1575
Vendense en casa de Francisco Castillo librero a la Corregeria vieja

LIBRO DE

Regla vndecima, para la segunda tabla general del cap. 27.

Multiplica el seno recto del complemento de la inclinacion de la plana superficie por el seno recto del complemento del angulo de la regla 6. deste, y lo que se hiziere, partirlo has por el seno recto de la inclinacion de la raya Meridiana, que se halla por la regla 10. y ternas el seno recto del cõplemento del arco que buscas.

No ponemos el capitulo 29. en el qual pensauamos tratar de los fundametos y causas desta materia de Reloges, porque muy presto plaziendo a Dios sacaremos vn libro en lengua Latina, que tratara de todas las demonstraciones de las tablas deste libro, y de muchas otras que no estan aqui, donde se darã exemplos de todas las reglas muy extensos.

Fin del libro de Reloges solares.

Impresso en Valencia, en casa
de Pedro de Huete a la
placa de la Yerua.

1576.

FIGURE 3: Pedro Roiz, Valencia, 1575

FIGURE 3A: Last page of Roiz's work

IOANNIS PADVANI
VERONENSIS

*De compositione, & usu multiformium Horologiorum Solarium ad omnes totius orbis
Regiones, ac situs in qualibet
superficie:*

Opus nunc denuo ab ipso multis in locis illustratum, & auctum.

Adiectæ sunt præterea peculiæ Methodi ad dignoscenda stellarum loca, & supputandas quascunque tabulas, tam per minutissimum calculum, quàm per instrumentum nunquam hæctenus ab ullo excogitatæ.



Venetis, Apud Franciscum Franciscum Senensem, 1582.

FIGURE 4: Joannis Padvanni, Venice, 1582

FABRICA
ET VSVS
INSTRUMENTI
AD HOROLOGIORVM
DESCRIPTIONEM
PER OPPORTVNI.

ACCESSIT RATIO DESCRIBENDARVM
horarum a meridie & media nocte exquisitissima,
& nunquam ante hac in lucem edita.

AUCTORE
CHRISTOPHORO CLAVIO
BAMBERGENSI SOCIETATIS IESV.



ROMAE, Apud Bartholomæum Grassium. 1586.
PERMISSV SVPERIORVM.

FIGURE 5: Christophoro Clavio, Rome, 1586

3. Pedro Roiz, 1575. *Libro de Reloges solares. Compesto por Pedro Roiz Clerigo Valenciano, discipulo del Maestro Hieronymo Muñoz en qual muestra a hazer relojes, en llano, y en paredes a qualquier viento descubiertas, leuantadas a plosmo, o inclinadas bazia tierra, y otras cosas para esto necessarias*. Dirigido al mvy Illustre Senor Don Joan de Borja, hijo del Illustrisimo Reuerédissimo Senor Don Pedro Luys Galceran de Borja, Maestre de Montesa, y Marques de Nauarres. Con Licencia. Impresso en Valencia en casa de Pedro de Huete, Año de 1575. Vendense en casa de Francisco Castillo librero a la Corregeria vieja. In the scroll at the base of the coat of arms is "Petrus LvdoVICUS Galceran Dvsborgia Magister Motesia".

Book of Sundials composed by Pedro Roiz, Valencian cleric, Disciple of Master Heironymus Munoz . . . The first dialling work written in Spanish. The book had 124 pages, the last page of which is shown here. It mentions Oronce Finé as the great mathematician and also his book on sundials. The last page of the book gives the date of printing as 1576. There must have been some delay in publishing the work. This book was produced in facsimile in 1980 in a limited edition of 250. A review of this work, by Charles K. Aked, was published in *Antiquarian Horology* Vol. XII, No. 5, Spring 1981.

This is not the first book on dialling in the Romance language, for Hugo Helt published *Descriptions and Uses of Spanish Sun-Clocks* in 1549.

4. Joannis Padvanii, Verona, 1582. *De compositione, & usu multiformium Horologiorum Solarium as omnes totius orbis Regiones, acsitus in qualibet superficie: Opus nunc denuo ab ipso multis in loci illustratum, & auctum*.

Adiectæ sont præteræ peculiare Methodi ad dignoscenda stellarum loca, & supputandas quascunque tabulas, tam per minutissimum calculum, quam per instrumentum nunquam hactenus ab vlllo excogitate. Venetys, Apud Franciscum Franciscum Seaensem, 1582.

Book of making and use of many forms of sundial for diverse regions of the world on plane surfaces of walls. New edition with many illustrations. The author wrote a number of dialling treatises, this one was produced in a number of editions.

The figure is that of Peace holding an olive branch, with a cornucopia of fruit under her right hand. The text is in Latin, the universal language of the Middle Ages.

5. Christophoro Clavio, Rome, 1586. *Fabrica et Vsvs Instrumenti ad Horologiorvm Descriptionem per Opportvni. Accesit Ratio Describendarum horarum a meridie & media nocte exquisitissima, & nunquam ante hac in lucem edita*. Avctore Christophoro Clavio Bambergensi Societatis Jesv. Romae, Apud Bartholemæum Grassium. 1586. Permissv Sveriorum. Latin text.

Making and use of instruments such as horologia, with useful descriptions . . . Author Christopher Clavius, Member of the Society of Jesus. One of the best early treatises on the astrolabe, and perhaps one of the fullest treatments of the period. First edition Rome 1586, another 1593; another Rome, 1599.

6. Don Valentino Pini, 1598. *Fabrica de gl' Horologi Solari. Nella quale si trattano non solo Instrumenti per dissegnare horologi sopra ogni suerficie di muro ma acncò si danno regole per fabricare altri Horologi portatili così per seruitio del giorni, come della notte*. Di Don Valentino

Pini Can^{co} Reg^{re} della Cong^{ne} del Salvat^{re}. Con Licenza de Superiori & Con Priuilegio. In Venetia Appresso Marco Gvarisco MDXCVIII. In the scroll under the sundial is "TEMPESTIVE EXCVBANDVM" - (Keep watch of time). Italian text.

Making of Sundials, in which is treated not only instruments for designing dials on any surface of a wall but also gives rules for making other portable clocks which serve for day as well as night. By Valentino Pini.

7. Anonymous - *Arte de hacer relojes Horicontales y Verticales por Arithmetica*. Manuscript of 320 quarto pages with figures. Art of making Horizontal and Vertical clocks by Arithmetic. According to the dial at the top of the title page, the date of compiling was 1620. This must have been prepared for publication to have such a sophisticated and elaborate design for a title page. Many such manuscripts never reached the printer but were usually compilations of the work from other authors prepared by pupils learning the art of dialling, or by a tutor for the course work for his students. Spanish text.

8. Bartolemeo Scanavacca, 1688. *Novissima Inventione. Per dissegnare con grandissima facilità, et prestezza Horologi Solari, Italiani, Babilonici, e Francesi*. Con alcun Tavole, nelle quali immediate si vede ogni giorno del l'Anno in perpetuo. Il nascer del Sole, la lunghezza del giorno, il mezo giorno, la mezza notte, il loco del Sole nel Zodiaco, la declinatione del medemo dall 'Equatore, gl 'Archi Seminotturni, Semidiurni, & anco gl 'Archi intieri Diurni, & Notturni.

Data in luce à commun beneficio dal Molto R. P. D. BARTOLOMEO SCANAVACCA. Della Congregatione, de 'Preti Secolari di S. Fillipo Neri di Padova. Al L' Illustriss. Et Eccellentiss. Sig. GIROLAMO GRADENIGO Dignissimi Procurator di S. Marco. In Padova, Nella Stamperia del Seminario. Per Bernardo Luciani. 1688. Con Licenza de' Superiori, e Privilegio.

New Invention. For designing with the greatest facility, and precision Italian, Babylonian, and French Sundials. With some tables, . . . In Padua under the stamp of the Seminary, by Bernardo Luciani 1688. Italian text.

9. Lodovico Quadri, 1733. *Tavole Gnomonische per Delineare Orologj a Sole. Che mostrino l'ore conforme a quelle degli Orologi che suonano, Con altre Tavole che servono per las costruzione de' medesimi, e per altri usi. Calcolate da Gio: Lodovico Quadri*. Associatio all' Accademia dell' Istituto delle Scienze di Bologna. Nella Stamperia di Lelio della Volpe. MDCCXXXIII. Con Licenza de' Superiori. Italian text.

Gnomonic Tables for delineating Sundials for showing the hour with other tables which serve for constructing the same and for other uses, calculated by Gio. Lodovico Quadri. Associate of the Institute of Science of Bologna. Under the stamp of Lelio della Volpe. 1733. With License of the Superior.

This treatise is usually bound with *Tavole per regolare di giorno in giorno gli a ruote*. (Table to regulate a clock with wheels, day by day). This is a set of equation tables in order to convert from local solar time to mean solar time in order to regulate a mechanical clock, the earlier tables evidently being in error or lacking in some way. Published in Bologna, 1736.

(See following pages for Figures 6-9.)

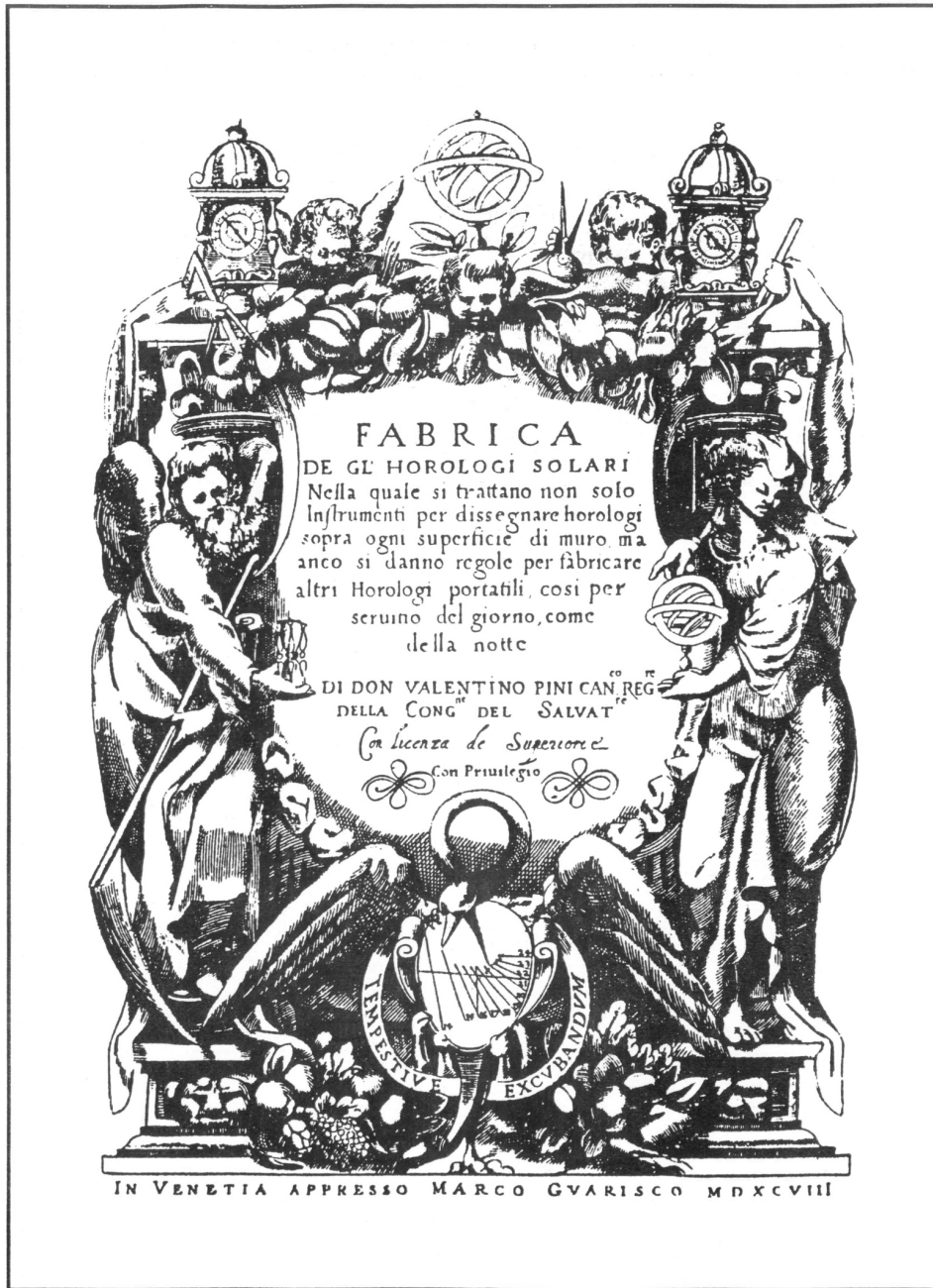

FIGURE 6: Valentino Pini, Venice, 1598



FIGURE 7: Anonymous, Spain, 1620

NOVISSIMA INVENTIONE

*Per dissegnare con grandissima facilità, e prestezza
Horologi Solari, Italiani, Babilonici, e Francesti.*

Con alcune Tavole, nelle quali immediate si vede ogni giorno del-
l'Anno in perpetuo Il nascer del Sole, la lunghezza del
giorno, il mezo giorno, la meza notte, il loco del Sole
nel Zodiaco, la declinatione del medemo dall'Equa-
tore, gl' Archi Seminotturni, Semidiurni, &
anco gl' Archi intieri Diurni, & Notturni.

Data in luce à commun beneficio dal Molto R. P.

D. BARTOLOMEO SCANAVACCA

Della Congregatione, de' Preti Secolari di S. Filippo Neri di Padova.

ALL'ILLUSTRISS. ET ECCELLENTISS. SIG.

GIROLAMO GRADENIGO

DIGNISSIMO PROCURATOR DI S. MARCO.



IN PADOVA.

NELLA STAMPERIA DEL SEMINARIO.

Per Bernardo Luciani . 1688.

Con Licenza de' Superiori, e Privilegio.

FIGURE 8: Bartolomeo Scanavacca, Padua, 1688

TAVOLE GNOMONICHE PER DELINEARE OROLOGJ A SOLE

Che mostrino l' ore conforme a quelle degli Orologj,
che suonano

CON ALTRE TAVOLE

Che servono per la costruzione de' medesimi,
e per altri usi

CALCOLATE DA GIO: LODOVICO QUADRI

Affociato all' Accademia dell' Istituto delle Scienze

DI BOLOGNA.

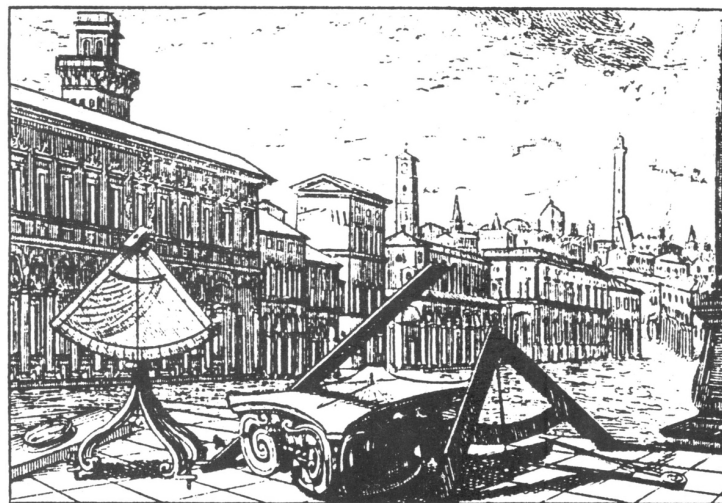

IN BOLOGNA

Nella Stamperia di Lelio dalla Volpe. MDCCXXXIII.

CON LICENZA DE' SUPERIORI.

FIGURE 9: Lodovico Quadri, Bologna, 1733

A MEDIEVAL ECCLESIASTICAL SUNDIAL AT RÁCKEVE, HUNGARY

LAJOS BARTHA AND DR. SZILVIA A. HOLLÓ

During a recent restoration of the wall paintings on the late Gothic Greek Catholic Church at Ráckeve, Hungary (near the Danube, 45 km's south of Budapest), there came to light, under the whitewash layer, a number of lines forming a sundial. Traces of the black lines were found on the oldest layers of the plaster coating. (Personal report from D. Eng, Gyula Káldy, a member of the National Centre for Restoration of Monuments).

This Greek Catholic Church was erected by Serbians who had emigrated to Hungary around the year 1440 to escape the Turkish expansion on the Balkan Peninsula. The popular Hungarian name for the Serbian nation is "Rác" and the immigrants came from the town of Keve - known as Kovin today, close to the lower Danube. The beautiful Gothic church was founded in the year 1478 and enlarged in the year 1771. A separate clock tower was built close to the church in 1758, the church had its first great restoration in 1771, followed by a clock installation in 1776.¹

The sundial is inscribed on the second half-pillar by the corner of the south wall and the apse facing east, see Fig. 1. The face of the pillar is inclined ten degrees to the east from south. The horizontal gnomon is 12 inches long at a height of 2.5 metres (approximately 8½ feet). The hour lines, painted black, are 22-25 cm in length, extending from 8 am to 3 pm, see Fig. 2.

The marking of the hours is most interesting. The medieval Cyrillic script characters mark the hours in place of numbers: (See Figs. 2 and 3)

1 = A, 2 = B, . . . and so on.

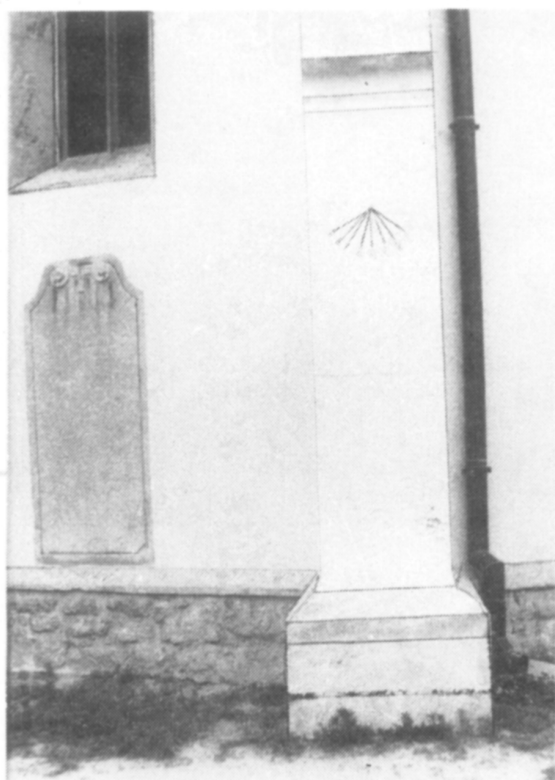

FIGURE 1: The medieval sundial on the ESE half-pillar of the Greek Catholic Church (Serbian) at Ráckeve, Hungary

Similarly these are shown in the old Greek script and Byzantine style. This type of Cyrillic lettering served to the turn of the 17th/18th century. In the drawing illustrated here (Fig. 3), the inner marking of the hours is in Cyrillic characters, the outer semicircle carries the equivalent Arabic numerals.

An analysis of the division of the hour lines reveals no mathematical or geometrical pattern. The angles of the hour lines to the vertical midday line (i) and the angular difference between pairs of lines (di) are given in the following table. (C is the Cyrillic character for the hour.)

Hour	C	i	di	Hour	C	i	di
8 am	И	61°	12°	12 noon	BI	0°	18°
9 am	θ	47°	9.5°	1 pm	A	18°	18°
10 am	I	37.5°	18°	2 pm	B	36°	17°
11 am	AI	19.5°	19.5°	3 pm	f	53°	

It is well known that a horizontal gnomon casts a different angular shadow for a given hour throughout the year. The diagram (Fig. 3) indicates the shadow-lines for the geographical latitude at Ráckeve (47.3°) for the summer solstice (s), and the two equinoxes (e). Comparison of the

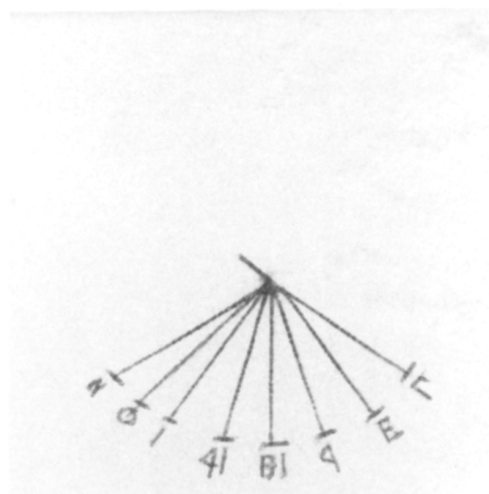

FIGURE 2: A closer view of the Ráckeve church dial, showing the hour lines

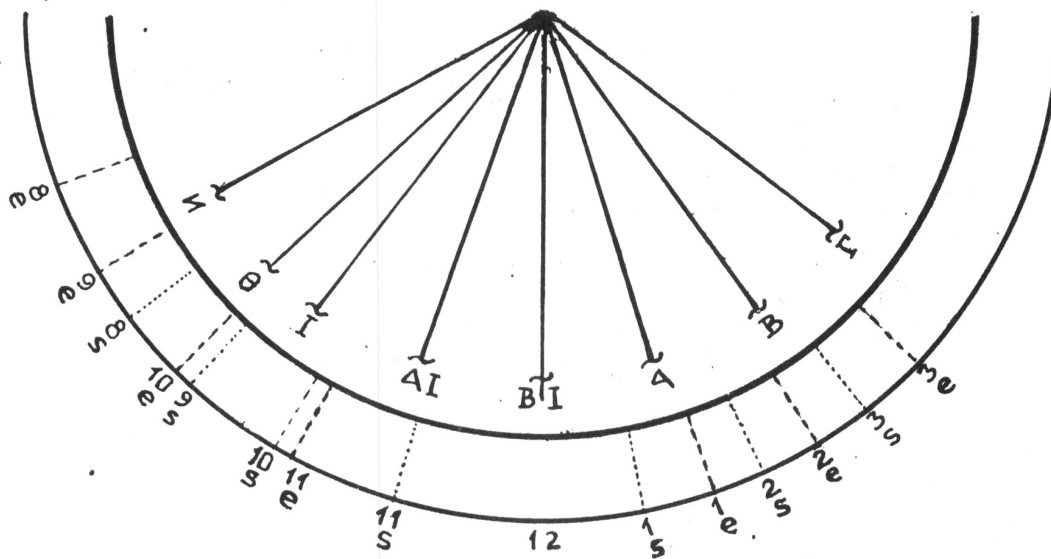

FIGURE 3: Explanatory diagram of the Ráckeve dial

calculated angles with the position of the hour lines indicates that the forenoon lines were drawn with the help of a watch or clock some weeks before or after the summer solstice. The afternoon lines show no connection with this kind of determination.

The opinion of the authors is as follows:

The sundial is older than the mechanical clock in the tower (1776), and perhaps was made some time before the end of the seventeenth century. After the erection of the clock, the construction of an old-style sundial would be senseless, and the numbering of the hours with Cyrillic letters indicates the earlier origin at the turn of the 17th/18th century.

Perhaps a simple ecclesiastical sundial (with possibly twelve divisions) was scratched in the stone pillar at the same time as the erection of the church in 1487 to indicate the times of the church services. Later the stone surface was covered with plaster but the lines of the sundial were painted on the new surface, over the position of the old scratch dial. After each new coating of whitewash, or restoration of the plaster, the sundial was newly-painted again. With the erection of the clock tower and installation of the mechanical clock, the difference in indication between clock and dial would highlight the difference between the solar time of the sundial and the the mean time shown by the clock. The church authorities made an attempt to correct the "wrong" sundial lines with the help of the mechanical clock but without success in the absence of gnomonic knowledge. In later times the inaccurately delineated sundial was replicated on the new whitewash layers.

If our deductions are correct, this is the only Greek Catholic ecclesiastical sundial in the north of the Balkan Peninsula. But in the Balkans, mainly in the area of the former Yugoslavia, on the walls of the old monasteries and churches were to be found more medieval scratch dials.² The Greek Catholic ecclesiastical sundials are based on the late Greek-Roman and the Byzantine sundials: a semicircle divided into twelve equally spaced sectors to indicate temporal hours. From the early Middle Ages, the nominal hour lines were marked with Cyrillic letters.

Dr. Milutin Tadić (Sarajevo) discovered seven ecclesiastical scratch dials in Yugoslavia. These are similar to the sundial in Ráckeve and two of these are older than the Hungarian example. The similarity between the Hungarian example and the original Greek Catholic Serbian sundials confirm our opinion of the history of the sundial at Ráckeve.

REFERENCES

1. Dercsényi, D. (Editor). Pest megye muemékei, II. (Monuments in the country). *Pest*, Vol. II. Budapest, 1956, pp. 18-28.
2. Tadić, M. Catalogue of the Antique and Middle Age Sundials in Yugoslavia. Publication of the Astronomical Observatory Sarajevo, 1986.

ACKNOWLEDGEMENTS

Photographs 1 and 2 were supplied by Mrs. S. Holló.

THE THEORY OF EQUIVALENT SUNDIALS

ERWIN H. OVERKAMP (GERMANY)

Duplicates of sundials at various points on the surface of the Earth show identical readings if they are adjusted in conformity with the rules of the Theory of Equivalent Sundials. All these sundials can be reduced to a distant point at which the original dial is adjusted horizontally, for convenience called the Point of Origin. This theory - known since the ninth century - is applicable to all kinds of sundials, it explains the conditions for their displacement and the dissimilarity between the hours of sunshine, and the duration of the solar irradiation, but besides these, there are significant simplifications for the design of sundials in non-horizontal adjustments. For all computations only the two formulae of Section 3 are needed.

1. FUNDAMENTALS OF THE THEORY OF EQUIVALENT SUNDIALS

The conditions for identical readings in various points of the surface of the Earth are the equivalence of the adjustment of the sundial planes with reference to the position of the Sun and the simultaneousness of the solar irradiation.

The equivalence of the adjustments will be described in accordance with Figure 1 in which the following notations are used: N = North Pole, P_o = point of horizontal and P_a = point of non-horizontal adjustment of the sundial respectively. Assuming that the geographic coordinates $\lambda_o \phi_o$ of P_o and $\lambda_a \phi_a$ of P_a are known, in the spherical triangle $P_o P_a N$ the side Z_a and the angles ω and $N P_a P_o$ can be computed, the angle A_a can be deduced from the latter. Two rectangular coordinates systems $x_o y_o$ and $x_a y_a$ will be provided for, they have a common zero in P_o and their y-axes differ by the angle ω which is enclosed by the meridian through P_o and the great circle connecting P_o and P_a .

The equivalence of the sundial planes in P_o and P_a is ensured if the y_{a-} axis and the normal to the sundial planes are adjusted in P_a in the said great circle and there, the normal remains parallel to that in P_o .

The plane of the adjusted sundial forms with the horizon in P_a the angle Z_a which is equal to the angular distance between P_o and P_a . The proof of this can be deduced from the plane triangle $P_a C T$ in Figure 2, there the centre of the Earth is denoted by C. In the case the sundial is adjusted in P_a' , its plane faces the surface of the Earth and not the sky, the angle Z_a' exceeds 90° .

The angles A_a and Z_a suffice to describe the adjustment of a sundial plane in a horizon system completely, in P_o the values $A_a = 180^\circ$ or 360° and $Z_a = 0^\circ$ are decisive.

The second condition for an identical reading in P_o and P_a is satisfied if two relevant zenith-distances do not exceed the following values:

- in P_a : $ZD_a \leq 90^\circ$, that is during the hours of sunshine.
- in P_o : $ZD_o \leq 80^\circ$, this is the maximum admissible value to cast a readable shadow on the sundial plane.

The hours of sunshine in P_a as well as the duration of the solar irradiation in P_o and thus the limitation caused by the displacement of sundials can be deduced from Figure 3. In the point B_s a light beam from the centre of the Sun passes through the surface of the Earth on its way to the centre.

The simultaneous irradiation in P_o and P_a is ensured if B_s is located in the spherical surface EFMLRE overlapped by both circles around P_o and P_a having the said corresponding zenith-distance as their radii. In this general situation, two limiting cases are to be mentioned:

- P_a'' is located on the great circle through P_o and E in a distance of $Z_a'' = ZD_a'' + ZD_o = 170^\circ$ from P_o . The simultaneous solar irradiation occurs only once a year if B_s coincides with E.
- If the circle with the radius $ZD_a = 90^\circ$ around P_a overlaps the curves EK and FM, no dissimilarity exists between the solar irradiation of the sundial in P_o and P_a respectively.

2. APPLICATION OF THE THEORY OF EQUIVALENT SUNDIALS

A few examples follow for the use of this theory.

2.1 Duration of the Solar Irradiation in P_a

The start/end of the solar irradiation in P_a can be calculated for every declination δ of the Sun, but in most cases it suffices to restrict these computations to the solstices and the equinoxes. The calculations are referred to the time system to be read in P_a defined by its reference meridian λ_t . The following steps are to be carried out:

- insert on a straight line representing the equator: $\lambda_o \lambda_a$ and λ_t in the scale of degrees, west-direction to the left.
- compute the local hour angles from the declination, the latitudes and the values $ZD_o = 80^\circ$ for P_o and $ZD_a = 90^\circ$ for P_a respectively.
- insert the results on the said line.
- establish a common counting system proceeding from $\lambda_t = 180^\circ$ and transfer the values of $\lambda_o \lambda_a$ and of the two pairs of hour angles to this system.
- select the two points nearest to λ_a in eastern and western directions and transform values to the system of hours.

The result is the start/end of the solar irradiation in P_a expressed in solar time of λ_t .

2.2 Direct Displacement of Sundials

An horizontal sundial may be designed for P_o , the angles $A_a Z_a$ and ω can be computed according to Section 1. After inserting the y_{a-} axis on the sundial's plane with the aid of the angle ω , all necessary values are obtained to adjust the sundial in P_a . The opposite displacement of a sundial from P_a to P_o or to another location of P_a follows the same rules. In the latter case the detour through P_o must be applied.

It is recommended to design the sundial for the time system to be read in P_a , so no difficulties arise regarding the interpretation of the readings in P_a . If the reference meridians λ_t of the time system for the design and that for the readings are dissimilar, the latter must be allowed for by a constant amounting to $1/15 \Delta \lambda_t$. Such a solution impedes the interpretation of the readings or it may make the sundial unsuitable for common use.

As far as altitude-sundials are concerned, the plumb line reference in P_o is replaced in P_a by the normal to the artificial horizon displaced from P_o to P_a . This indication has been made for reason of completeness only.

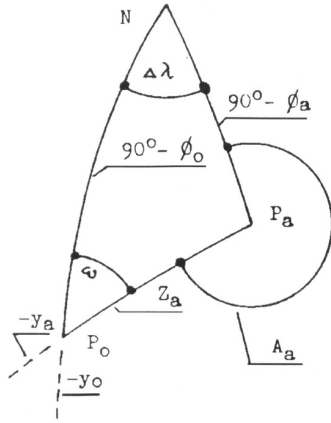

FIGURE 1

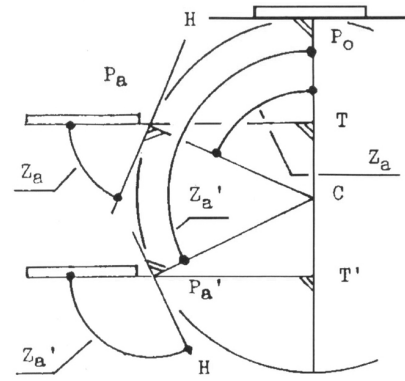

FIGURE 2

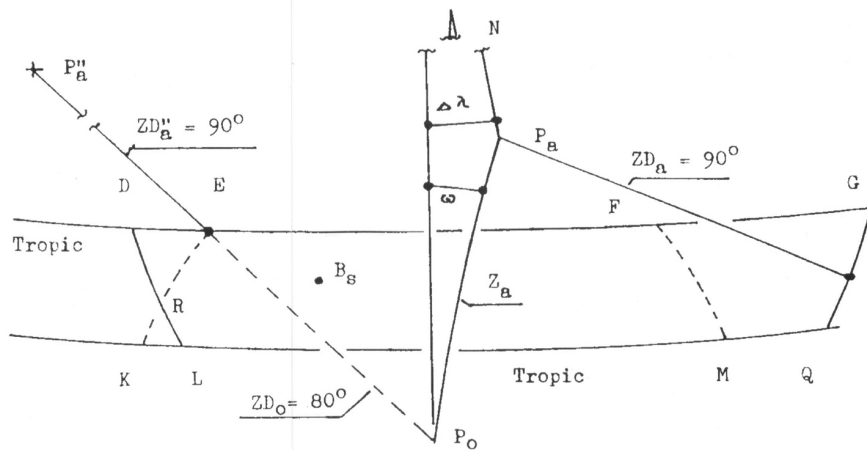

FIGURE 3

TABLE 1

Explanations			Adjustments				
			I	II	III	IV	V
Ref. Meridian of App. Solar Time	λ_t	hours : min.	+ 7.25			+ 15.00	+ 30.00
Geographic Coordinates of P_o	λ_o		- 7.75	- 7.25	+ 7.25	+ 15.00	+ 45.00
	ϕ_o		- 30.00	+ 30.00	- 30.00	+ 30.00	- 30.00
Angles of Adjustment in P_a	A_a		193.06	180.00	180.00	162.04	147.96
	Z_a		82.56	21.50	81.50	22.26	88.00
	ω	9.34	0.0	0.0	12.80	22.42	
Numeration of Substyle			13:00	12:00	12:00	12:00	11:00
Readings in P_a	Jun. 21.	from to	8:55 17:05	5:55 18.05	7:55 16:05	5:55 18:05	6:55 15:05
	Dec. 21.	from to	8:15 + 15:45 +	8:15 + 15:45 +	8:15 + 15:45 +	7:55 + 15:15 +	9:45 + 17:05 +

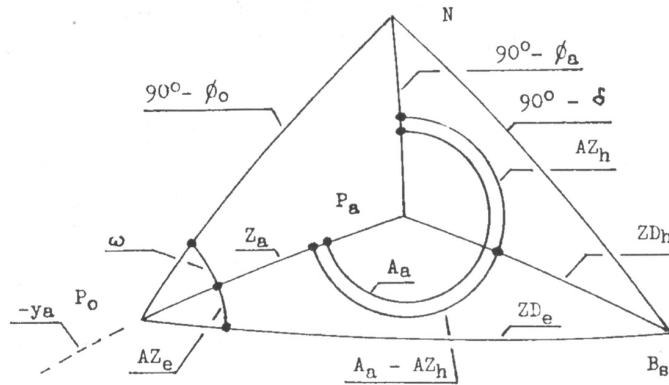

FIGURE 4

2.3 Indirect Displacement of Sundials

The application of the Theory of Equivalent Sundials for the design of non-horizontal sundials is described here below in accordance with Figure 4.

It is supposed that the geographic coordinates of P_a , the angles Z_a and A_a as well as the Sun's declination and the local hour angle $P_a N B_s$ are known, the latter calculated in the time system to be read in P_a . The zenith-distance ZD_h and the azimuth AZ_h can be computed, both of them are related to the horizon in P_a . In the spherical triangle, $P_0 B_s P_a$ are known: Z_a , ZD_h and the enclosed angle $A_a - AZ_h$, thus the side ZD_e and the angle AZ_e can be calculated.

The angle AZ_e refers to the y_a - axis, thus the position of the shadow on the sundial can be expressed directly in the coordinates system x_a, y_a which is unique for the adjustment of the sundial in P_a . This method of calculation is one of the essentials of the Theory of Equivalent Sundials and it can be incorporated easily in a computer programme, additional formulae are not needed. The knowledge of the geographic coordinates of P_0 and the angle ω is not necessary.

It is possible to allow for the effects of the parallax and of the atmospheric refraction on the position of the shadow in P_a if the calculated value of ZD_h will be reduced by the sum of them.

2.4 Examples for Direct Displacements

A sundial may be designed for the reading of the local apparent solar time on a latitude of $\phi_0 = 30^\circ$, the location of P_0 may be either in the northern or in the southern hemisphere. The substyle line may be marked but neither it nor the hour lines will be numerated. A few proposals will be made for the adjustment of the sundial in P_a having the geographic coordinates $\lambda_a = +7^\circ.25$ east and $\phi_a = +51^\circ.50$ north, the results are indicated in Table 1.

The position of P_0 have been selected in the proportion that the difference between the reference meridians λ_t of the time system derived in P_0 and that to be read in P_a is either zero or a multiple of 15° equal to one hour. The numeration of the substyle line refers to this difference $\Delta \lambda_t$, see especially the Adjustments I and IV, the remaining hour lines are to be denoted accordingly, thus no corrections for the interpretation of the readings are to be applied. The duration of the solar irradiation in P_a is indicated for the solstices, the points of time refer to the

apparent solar time of the selected references meridian λ_t . By consideration of the Equation of Time, the Standard Time can easily be obtained for the adjustments IV and V. As far as the readings in P_a are limited by the sunrise/sunset in P_a , these moments are marked by a plus-sign (+). This indicates that the sharpness of the shadow suffers loss at zenith-distances near to $ZD_a = 90^\circ$ in P_a due to the absorption of light in the atmosphere.

2.5 Determination of the Location of P_0

In most cases the adjustment angles A_a and Z_a are given by the local situation but sometimes it occurs that they are selectable. Thus the most favourable location of P_0 can be determined.

The steps of a relevant computation are listed here below under the assumption that the solar irradiation shall end in P_a at the moment of Sunset at the solstices, reference is made to Figure 3:

- omit P_0, P_a'' and all lines relevant to them.
- fix in a separate sketch the location of P_0 in a distance of $ZD_0 = 80^\circ$ from D and L respectively in the direction to P_a .
- compute the unknown angles and sides in the spherical triangles $D P_a N, L P_a N, D L N, D L P_0$ and $D P_0 N$ in the said sequence.

The results are the distance $N P_0$ and the angle $D N P_0$, thus the latitude ϕ_0 of P_0 is equal to $90^\circ - N P_0$, the longitude λ_0 of P_0 can be calculated from the computed angles at N with reference to the longitude λ_a of P_a . This computation can be carried out for every pair of points of intersection between the circle with $ZD_a = 90^\circ$ around P_a and any declination line or lines, such as the tropics.

3. FORMULAE

The previously mentioned computation in spherical triangles are carried out according to the following formulae given in their general form:

$$\cos c = \cos a \cdot \cos b + \sin a \cdot \sin b \cdot \cos \gamma$$

$$\cos \alpha = \frac{\cos a - \cos b \cdot \cos c}{\sin b \cdot \sin c}$$

In this triangle the angles are denoted by α, β, γ and the opposite sides by a, b, and c.

OF ANALEMMAS, MEAN TIME AND THE ANALEMMATIC SUNDIAL - PART 2

FREDERICK W. SAWYER III (USA)

There is an interesting irony in the fact that the analemma ('figure 8') curve has become a familiar feature on the classical sundial over the last century and a half, but has only rarely been seen on the analemmatic sundial.¹ One might expect the similarity in names to suggest more of a kinship between the dial and the curve. The purposes of the present article are (in Part 1) to consider this irony - a consideration which requires something of an etymological journey - and (in Part 2) to elaborate on the design of a standard-time analemmatic sundial which reinforces the kinship by reuniting the dial and the curve.

EXPERIMENTS WITH ANALEMMAS

The ancestor of all existing analemmatic sundials, the dial which Lalande rebuilt in 1756 at the church of Brou, was restored once again in 1902. The craftsman charged with its restoration was an amateur diallist who decided to overlay an analemma curve on the meridian line. The dates were not marked on a linear declination scale; they were noted only on the curve itself. This situation quickly resulted in the common belief that the vertical gnomon or erect visitor should be stationed on the curve rather than the meridian in order to cast a shadow on the hour-ring.² There is of course no justification for this arrangement; it introduces significant error into the dial design.

In Kennett Square, Pennsylvania USA, not far from Philadelphia, there is a 1050 acre horticultural park, Longwood Gardens.³ The park is on the former country estate of Pierre S. duPont (1870-1954). The park's last construction project overseen by duPont was the design of a 37 by 24 foot analemmatic sundial in what is now a Topiary garden in the park. The dial was completed in 1939 after more than six years of daily noon-time observations:

In the late 1960's an analysis was done on the Longwood Gardens dial, enlisting the assistance of P. Kenneth Seidelman of the U.S. Naval Observatory. Measurements showed that the hour-points were positioned for standard time readings, but the double analemmas then at the centre of the dial⁴ proved to be little more applicable to a proper design than a single analemma. To address this problem, Seidelman developed a weighted average approach to defining substitute analemma curves which results in a close approximation to mean time.⁵ The engraving of a new pair of analemmas was undertaken in 1978, and the Longwood Gardens dial was thus corrected in a novel way. Our purpose here is to consider the mathematics of this approach.

STANDARD TIME ANALEMMATIC SUNDIAL

We begin by noting that the real challenge here is to move from apparent time to mean time. Since, for any location, the difference between standard and mean time is constant; the additional shift to standard time is simply a matter of relabelling the hour-points.

Equation [1] specifies the line of shadow which at mean time T will intersect the hour-point for T . Note that for the special case in which we ignore the equation of time (*ie.* set $\epsilon_\delta = 0$), dealing then only with apparent time, this equation collapses to the usual analemmatic sundial with all of the shadow lines for a given day intersecting the meridian at

the same point, $(0, \cos \varphi \tan \delta)$. However, once the equation of time enters the picture, the shadow lines for any given day no longer all converge. Instead, they all become tangent to a single curve (equations [2]), technically known as their envelope.

[1]

Determine the equation of the shadow of a vertical gnomon at mean time T , if the base of the gnomon is placed on the elliptical hour-ring at the point corresponding to time T

(*ie.* at point $x_t = \sin T, y_t = \cos T \sin \varphi$).

* * *

$$y \sin (T - \epsilon_\delta) = x (\sin \varphi \cos (T - \epsilon_\delta) - \cos \varphi \tan \delta) - \sin \varphi \sin \epsilon_\delta + \cos \varphi \tan \delta \sin T$$

[2]

Determine the envelope of the family of shadow lines which intersect the elliptic hour-ring at appropriate mean times T .⁶

* * *

$t = T - \epsilon_\delta$

$$x = \sin \epsilon_\delta \frac{\sin \varphi \cos t - \cos \varphi \tan \delta}{\sin \varphi - \cos \varphi \tan \delta \cos t}$$

$$y = \frac{\cos \varphi \tan \delta [\sin \varphi \cos \epsilon_\delta - \cos \varphi \tan \delta \cos T] - \sin^2 \varphi \sin \epsilon_\delta \sin t}{\sin \varphi - \cos \varphi \tan \delta \cos t}$$

The shape and orientation of the envelope vary from day to day; examples are given in figure [3], where selected shadow-lines ranging from sunrise through noon to sunset are shown, all tangent to their envelope. On days for which the solar declination is positive (assuming a location north of the equator), this parade of lines swings through at least 180° and in effect seals or closes the envelope; on days with a negative solar declination, the envelope remains open. Note also that a large absolute value for the equation of time results in a wider envelope. If the equation is positive, the envelope opens to the west; if negative, the opening is to the east.

If we now plot the envelopes for each day throughout the year (figure [4]) in their correct positions relative to each other, we find, not surprisingly, that they come together to form a figure 8 analemma.⁷ However, even though we make the usual assumption that the solar declination is constant on any given day, we do not have discrete points representing the correct gnomon position for each day; instead, we have small curves. To solve this dilemma, we will select average points to replace the curves, with the selection being made to minimise the error introduced by the averaging. Since experimentation shows that use of a single point for each day would result in no advantage over a traditional dial with no analemma at all,⁸ we will replace each day's envelope by two distinct points, one selected for use in the morning hours and one for the afternoon.

There are a number of approaches we can take at this

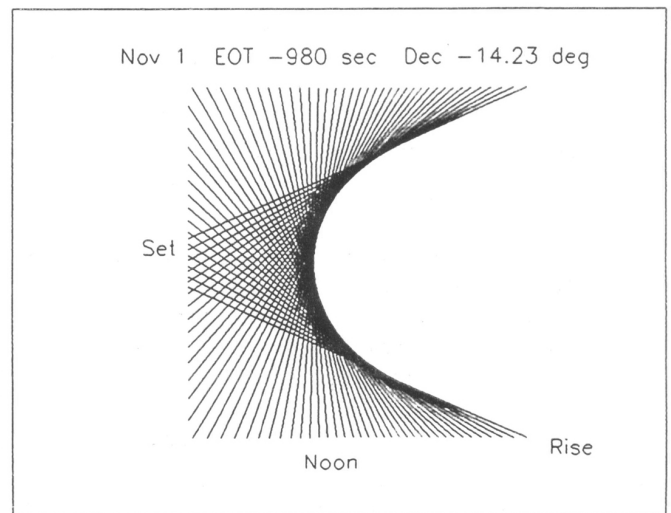
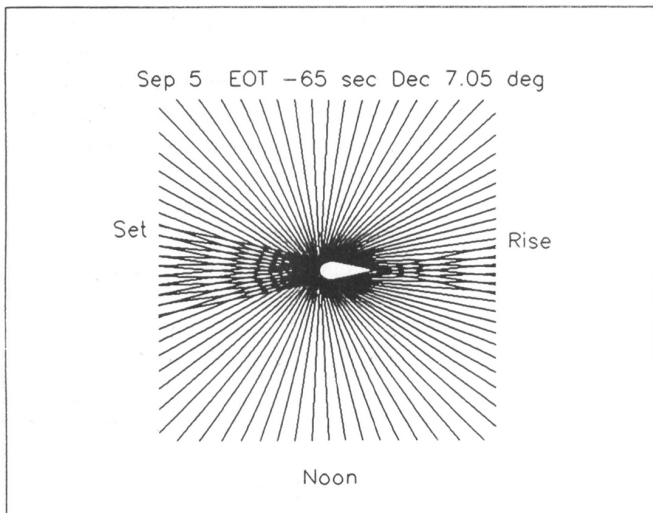
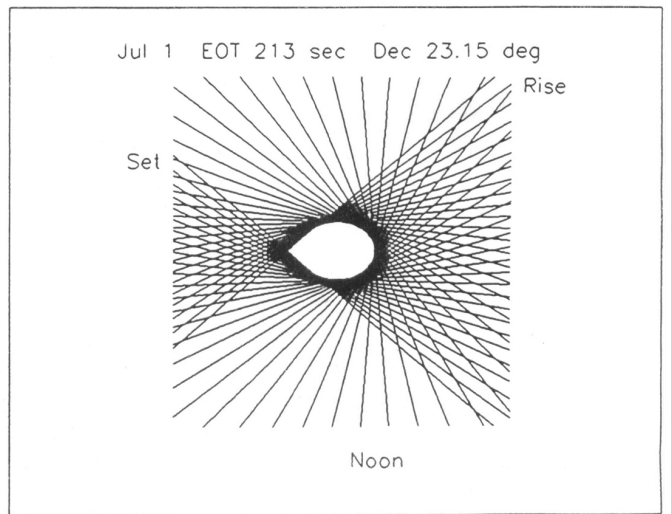
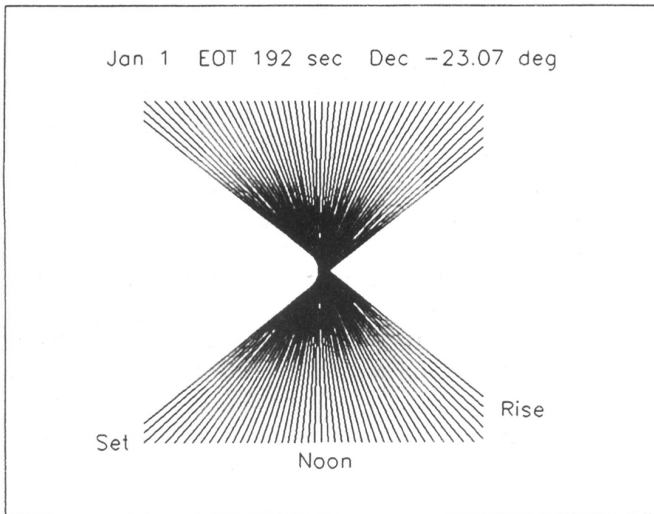

3. Envelopes of Shadow Lines Registering Mean Time on the Elliptic Hour Ring



4. Analemma of Envelopes



5. Overlay of Analemma

junction; we will briefly consider four options: **I-IV**, and the decision on which option to use is ultimately up to the individual diallist.

I.

Select a number of evenly-spaced *apparent* time (t) between noon and the time of sunset on the winter solstice. Find weighted averages of the coordinates of the points (x_t, y_t) on the envelope for the given date and associated with the selected times (equations [6]). To understand the rationale for the weightings to be used, consider two shadows: one falling in a North-South direction, and the other East-West. The placement of the gnomon casting the North-South shadow is very sensitive to the x coordinate of the point at its base, but is totally independent of the y coordinate. A change in the y coordinate will not change the line on which the shadow lies, but any change in the x coordinate will place the shadow on a totally different line. Similarly, for an East-West shadow, the gnomon's placement is sensitive to the y coordinate and insensitive to the x coordinate. For shadows between these two, sensitivity to either coordinate will depend on the slope of the shadows; use of the sines and cosines of the shadow's azimuths as weights reflects this sensitivity.

This process is then repeated for the morning hours. The result is a pair of similar but not identical analemmas, as can be seen in figure [5], where such a pair, calculated for London, is shown with one curve overlaying the other.⁹

[6]

For a given date with solar declination δ , and selected apparent time t , with corresponding points (x_t, y_t) on the envelope of the shadow-lines, determine the weighted average coordinates of the date's analemma point (morning or afternoon).

$$\cot Z_t = (\cos t \sin \phi - \tan \delta \cos \phi) / \sin t$$

$$x = \left(\sum_t x_t |\cos Z_t| \right) / \sum_t |\cos Z_t| \quad y = \left(\sum_t y_t \sin Z_t \right) / \sum_t \sin Z_t$$

To implement the dial, we need only draw the two analemmas side by side and split the elliptical hour-ring at noon, with the space between the two halves equal to the space between the North-South axes running through the analemmas. The vertical gnomon is placed each morning on the appropriate date point of the west analemma, and at noon it is moved to the corresponding point on the east analemma. To adjust the dial from mean to standard time, simply relabel points on the ellipse to reflect the constant

difference between standard and mean times.

II.

To consider a second option, observe that if the intersection of the shadow-lines of any two of the selected apparent times (t) were used as the analemma point (equations [7]), then there would be no error in the dial reading at those two times. Indeed, if we selected an analemma point *within* the envelope, we would have no correct readings during the day; a point selected *on the* envelope produces only a single correct reading. But a point selected from a small region just outside the envelope, the region of intersecting shadow-lines which shows in figure [3] as cross-hatching, gives completely correct readings twice per day. Perhaps these are the points which should enter into the weighted average. Continuing the restriction that the apparent times (t) are either all morning or all afternoon times, the region of interest is further limited to the area bounded by the envelope, the noon shadow-line, and either the sunrise or sunset shadow-line.

[8]

For a given date with solar declination δ , N selected apparent time t , and the $N^2 - N$ pairwise points (j, x_k, y_k) of intersection of the corresponding shadow-lines, determine the weighted average coordinates of the date's analemma point (morning or afternoon).

$$\cot Z_k = (\cos t_k \sin \phi - \tan \delta \cos \phi) / \sin t_k$$

$$x = \left(\sum_j \sum_{k \neq j} x_j |\cos Z_k| \right) / (N - 1) \sum_k |\cos Z_k|$$

$$y = \left(\sum_j \sum_{k \neq j} y_k \sin Z_k \right) / (N - 1) \sum_k \sin Z_k$$

III.-IV.

As a third and fourth option for the definition of the two analemma curves, consider broadening the interval from which the apparent times (t) are selected. By using the interval between noon and sunrise/sunset on the specific given date, we decrease both the overall average and the absolute maximum deviation from mean time. The tradeoff is that the average deviation in the hours when the sundial is probably most often used goes up and the maximum error at noon increases.

Obviously, an important element in the evaluation of these various options is a measure of the error or deviation from mean time that they incur. Equations [9] provide a

[7]

Determine the point of intersection (${}_1x_2, {}_1y_2$) of the shadow-lines for mean times T_1 and T_2 corresponding to apparent times

$$t_1 = T_1 - \epsilon_\delta \text{ and } t_2 = T_2 - \epsilon_\delta.$$

$$M_\delta = \cos \phi \tan \delta$$

$${}_1x_2 = {}_2x_1 = \sin \epsilon_\delta$$

$$\frac{\sin \phi (\sin t_1 - \sin t_2) - M_\delta \sin(t_1 - t_2)}{\sin \phi \sin(t_1 - t_2) - M_\delta (\sin t_1 - \sin t_2)}$$

$${}_1y_2 = {}_2y_1 =$$

$$\frac{M_\delta [\cos \epsilon_\delta \sin \phi \sin(t_1 - t_2) - M_\delta (\sin T_2 - \sin T_1)] + \sin \epsilon_\delta \sin^2 \phi (\cos t_1 - \cos t_2)}{\sin \phi \sin(t_1 - t_2) - M_\delta (\sin t_1 - \sin t_2)}$$

means for determining the apparent time at which the gnomon's shadow crosses any given hour point. Following the calculation, a natural measure of measure of the error is to consider the difference between the time (T) registered by the shadow on the dial, and the actual mean time equal to the sum of the apparent time (t) at which the reading is made and the day's equation (ϵ_δ).

The deviations (in seconds) from mean time incurred by dials designed for London according to these four options appear in the following table:¹⁰

[9]

Given a vertical gnomon with base at point (x_δ, y_δ) , determine the local apparent time(s) t at latitude φ and solar declination δ at which the shadow of the gnomon will pass through the point (x_T, y_T) .

* * *

$$a = y_T - y_\delta \quad b = (x_\delta - x_T)\sin\varphi \quad c = (x_\delta - x_T)\cos\varphi\tan\delta$$

$$\sin t = \frac{ac \mp b\sqrt{a^2+b^2-c^2}}{a^2+b^2} \quad \cos t = \frac{bc \pm a\sqrt{a^2+b^2-c^2}}{a^2+b^2}$$

	I	II	III	IV
Average Deviation	44	46	38	32
Maximum Deviation	399	410	370	223
Average Deviation (Noon \pm 3.7 Hours)	15	14	31	30
Average Noon Deviation	49	40	87	80
Maximum Noon Deviation	120	99	203	198

Thus, if we choose option IV, by introducing a pair of analemmas we produce an analemmatic sundial we produce an analemmatic sundial which always registers within 4 minutes of mean time and on average errs by 32 seconds, little more than one-half minute. Although the deviation at mean noon, the time of shifting from one analemma to the other, can exceed 3 minutes, the average error when the dial records this time is within the limits of our ability to distinguish different readings on the dial. These values should be compared with the corresponding numbers for an uncorrected dial, with no analemmas; such a traditional dial located in London would have an average deviation from mean time of 385 seconds¹¹ and, of course, could suffer from an error in excess of 16 minutes.

A better sense of the deviations for option IV can be obtained from the following more graphic presentation, which also shows that for 90% of the time that the sun is above the horizon the dial's deviation from mean time is less than 69 seconds:

REUNION & SOURCES

Having presented the requisite formulas, we now see that the stray modern sense of *analemma* - with perhaps a slight evolution in its meaning - can be reunited with the

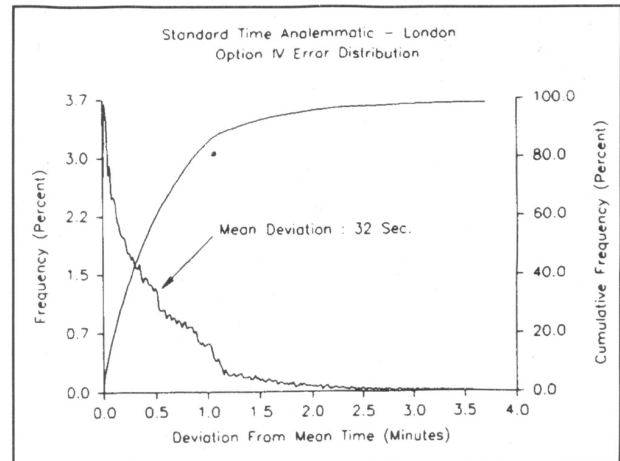

analemmatic sundial that already incorporates all of the prior historical senses of the word. The result is a dial which can provide a fair reading of standard time, yielding a level of accuracy well within the tolerance of most diallists.

To assure that a reading can be taken at all times the sun is above the horizon, the usual minimum value for the height of the gnomon is $1.09\cos(\varphi - 23.43^\circ)$ times the semi-major axis. This formula continues to be useful for the standard time analemmatic, only slightly understanding the required height.¹²

Similarly, in order to assure that the gnomon's shadow is sharp as it intersects the ellipse, the width of the gnomon should be approximately one percent of the semi-major axis of the dial.¹³

For the diallist interested in experimenting with this combination, a sample dial calculated for London (more specifically, for $51.53^\circ N$ $0.00^\circ W$) is presented on a separate page included with this issue of the Bulletin, see page 44. For diallists with access to an IBM compatible computer, software which calculates the coordinates of the analemmas and hour-points according to the various methods discussed here is currently available at a nominal charge directly from the British Sundial Society, see page 50.



BIBLIOGRAPHY

- JANIN, LOUIS, "Note sur le cadran solaire de Brou", *l'Astronomie*, Paris, February 1970, pp. 83-86.
- JANIN, LOUIS, *Le Cadran Solaire Analemmatique, Histoire et D veloppements*, Note 74.2057, Centre Technique de l'Industrie Horlog re, Besan on France, 1974.
- SEIDELMAN, P. KENNETH, *Analemmatic Sundials*, Typescript (received in correspondence), circa 1970.
- SEIDELMAN, P. KENNETH, "A Design for an Analemmatic Standard-Time Sundial", *Sky and Telescope*, December 1975, 50(6):368-369.
- THOMPSON, GEORGE, "The Longwood Sundial", *A Man and His Garden*, Chapter X, Longwood Gardens, Kennett Square PA, 1976.

REFERENCES

1. This article assumes a basic familiarity with the traditional analemmatic sundial. On a horizontal plane with coordinates pointing to the cardinal points, x increasing to the east, and y increasing to the north, the dial point corresponding to apparent time t is $(\sin t, \cos t \sin \phi)$. These points lie on an ellipse with an east-west semi-major axis of 1 and a north-south semi-major axis equal to $\sin \phi$, where ϕ is the latitude of the dial. The gnomon is a vertical rod positioned daily at point $(0, \cos \phi \tan \delta)$, where δ is the solar declination for a given day.
2. For a discussion of this situation and indignation it created among diallists, see Janin 1970.
3. The author is indebted to Colvin L. Randall of the Longwood Gardens staff for help in providing information on the history of the Longwood Sundial.
4. It is not clear when the double analemmas became part of the sundial. The published recollections of Knowles Bowen, the engineer, and comments by George Thompson, who was duPont's personal secretary (Thompson 1976), seem to suggest a single analemma on the original dial; this view is supported by the reports of noon-time readings being taken. However, no one seems to be able to recall a time when the dial did not have a double analemma arrangement, and there is a photo in the Thompson book (p.94) of Bowen with two gnomons astride two analemmas; the photo is undated.
5. Seidelman 1970 and 1975. Developing on this idea, a large sundial fountain with weighted-average double analemmas was designed by Albert M. Thorne for a mall area at the University of North Carolina at Charlotte. Unfortunately, funding was not obtained for the sundial fountain, and the Longwood Gardens dial remains as perhaps the only large standard time analemmatic sundial.
6. The easiest way to derive this equation is to apply l'Hôpital's rule to determine the limiting values for equations [7] as $t_2 \rightarrow t_1$.
7. Seidelman's only comment on this collection of envelopes is "The hourly positions of the gnomon are a helical curve, whose daily average is shaped like the figure eight" (Seidelman 1970, p. 4). If we treat the solar declination δ as a continuous quantity and calculate the envelope curve as well for times when the sun is below the horizon, we do in fact obtain a helical curve which winds itself into a figure 8. Note that a case can be made for the view that applying the term *analemma* to this and later curves discussed in this article amounts to an extension or further generalization of its meaning. For purposes of clarity, the illustration given here actually only shows the envelopes for every third day throughout the year.
8. For a London dial, use of a single analemma - one point for each day - would result in an average error in excess of 3 minutes, with extremes ranging as high as 16 minutes, and a variation within one day of as much as 12 minutes. The usual spatial symmetry of the analemmatic sundial about the meridian fails when we introduce the equation of time. Accounting for the equation requires nudging shadow lines a little closer to the meridian line on one side and a little further away on the other. Unfortunately, the equation of time does not change sign when the sun crosses the meridian.
9. Although none of the options presented here matches exactly the approach adopted by Seidelman 1970; this first option is perhaps the closest. Seidelman limited his average to the time interval corresponding to sunlight on the winter solstice day (1970, p.5), but the points selected to go into the average were not exactly on the envelope. He used the intersections of the shadows for successive hour-points, and he apparently dealt only with full hour intervals (p.4). If more points were selected, the interval between successive times would decrease, and the resulting points would all approach the envelope as a limit. Thus, this option may be viewed as Seidelman's 1970 technique applied to a larger number of points. Note that in Seidelman 1975 there is an indication that a wider interval was actually used for the Longwood Gardens dial, thus suggesting that the final implementation may have corresponded more to Option II.
10. A similar table for the Longwood Gardens site (39.8728°N, 75.6748°W) is given here, times in seconds:

	I	II	III	IV
Average Deviation	40	39	38	32
Maximum Deviation	359	341	266	216
Average Deviation (Noon \pm 4.5 Hours)	21	20	28	28
Average Noon Deviation	53	48	80	77
Maximum Noon Deviation	132	112	205	210
11. This value is an average of the absolute values of the equation of time, weighted by the duration of sunlight in London on the respective dates.
12. For London, the formula produces a height of 0.9615 times the semi-major axis. Actual calculation for the analemmas illustrated here shows that, for the standard time dial, at 12.05 pm on July 3 the gnomon height should be 0.979 times the semi-major axis. A weakness in most large analemmatic dials is that they seldom can incorporate gnomons tall enough to satisfy this formula; the Longwood Gardens gnomon would have to be more than 19 feet tall.
13. Janin 1974, p. 26.

British Sundial Society London

Designed for the Society by F.W. Sawyer III 1993
Std. Time Analemmatic Sundial for 51.53N 0.00W

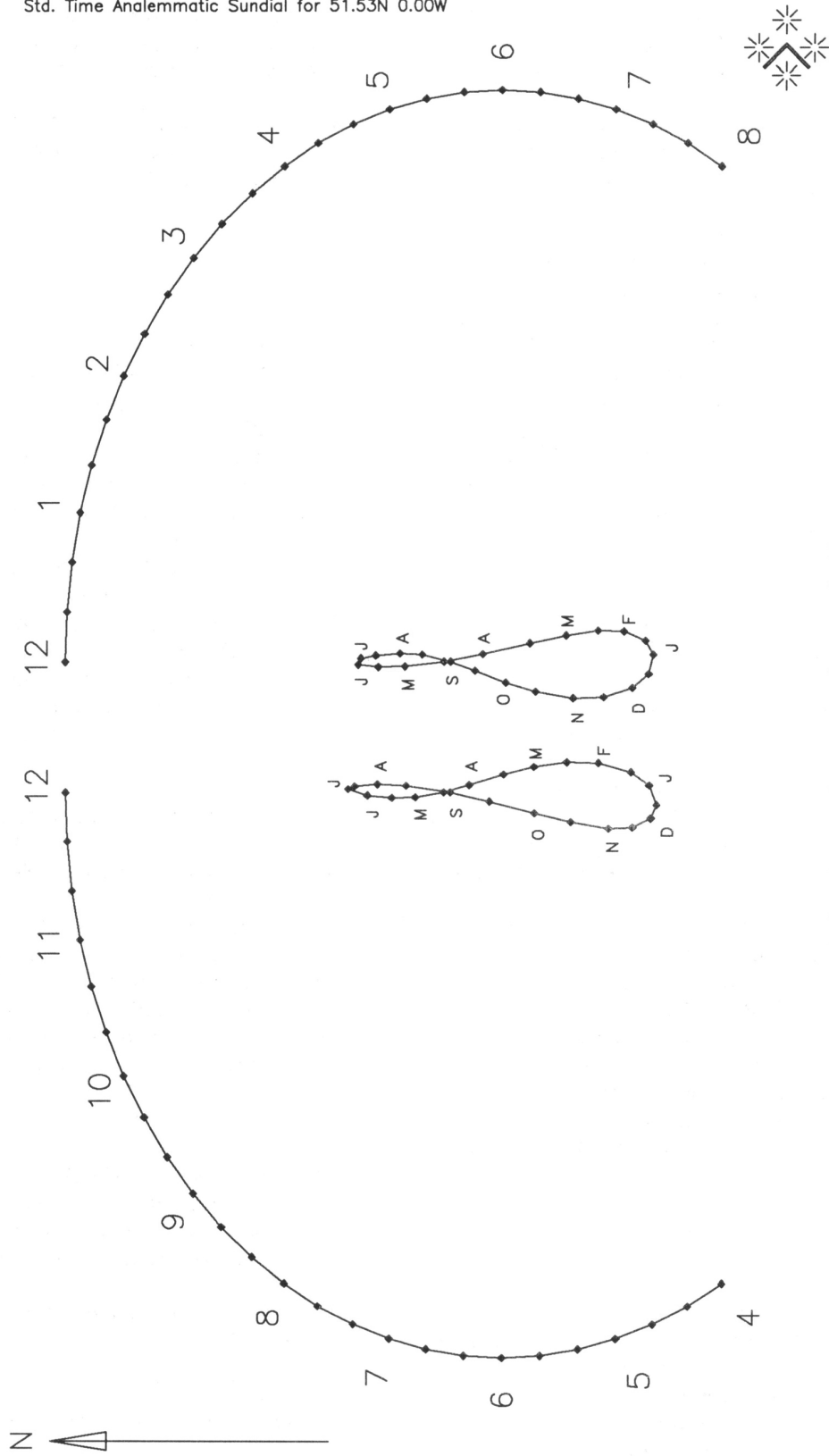

It is the silent voice of time
and without it the day were dumb.

For Summer Time, Add One Hour

READERS LETTERS

KIRCHER'S SUNFLOWER CLOCK

EDITOR'S NOTE: Mr. Bradshaw's letter in the October issue of the BSS Bulletin should have been modified before publication, unfortunately the first version was printed in error. Mr. Bradshaw wrote the following amendment on 22nd July 1994:

In reading my letter to you I find I have missed out some rather technical but very important words at the beginning of the second paragraph. Will you please amend your copy to read:-

"The second Greek word is misleading: the author and/or the engraver have written the first Greek capital letter E (epsilon), but it should be H (eta); there is also a horizontal blemish, either on the original paper or in the reproduction, which makes the second letter, which should be a Greek capital lambda (Λ), look like a capital alpha (A). With these errors put right (and there is no doubt about them) the correct transliteration . . ."

J. BRADSHAW
Dorchester

The Editor apologises for the non-inclusion of this correction to Mr. Bradshaws letter.

SUNFLOWER CLOCK ENGRAVING

Your correspondent George Wyllie (BSS Bulletin 94.2, p.40) is certainly correct in transliterating the second word of the Greek inscription on the engraving of the Sunflower Clock (93.2, p.42) as 'heliotropikon'. However, both he and W.A. Dukes (94.1, p.16) are in error in assuming that the second letter of this word is the Greek A (alpha). It is in fact Λ (lamda), which resembles an A without the crossbar. On the engraving as illustrated in the Bulletin, there appear many extraneous horizontal lines, and one such line happens to cross the lamda.

There is no Greek equivalent for our letter H. The Greek word in manuscript or in print, would appear as:

ἩΛΙΟΤΡΟΠΙΚΟΝ

The reversed apostrophe (rough-breathing) before the E (epsilon) indicates the 'h' sound. A rough-breathing would also appear before the letter omega, in the first word of the inscription. The engraver omitted this also.

MARGARET STAINIER
Cambridge

BRUNEL

Thank you very much for sending me a copy of the Bulletin which included the article about Brunel and the legend of Box Tunnel. I only spotted two errors in an article which must have been very difficult to transcribe from my original. Brunel was not born in 1993, and the broad gauge was 7ft 0¹/₄ in not 6ft 0¹/₂ in.

The legend about the odd ¹/₄ in is that Brunel ordered the engines for his first railway to have wheels 7ft apart and also started laying the rails 7ft apart. Only when the engines were delivered and first put on the rails did he find that he needed a little tolerance and decided that it was easier to widen the rails a bit than to alter the engines.

Yet another legend concerns the reason for the huge

entrances to Box Tunnel which you mentioned in the article. For the first few years of the railways the third class passengers were carried in open trucks and they had a tendency to take fright in tunnels. To reduce the terror, Brunel made the entrances to his tunnels extra large. Box Tunnel reduces to an ordinary section a hundred yards or so from each end. Brunel's idea, it is said, was that, once away from daylight, the passengers would not notice that the roof of the tunnel was only a little way above their heads!

DR. MARTIN BARNES
Kirtlington

QUEENS' COLLEGE DIAL

In René R.-J. Rohr's book *Die Sonnenuhr*, Munich 1982 is an illustration of the newly renovated Queens' College Sundial at Cambridge.

In making further enquiries, I am afraid that during one of the renovations something has gone wrong. In my opinion the lower row of figures, the moon's age should have been written from left to right:

30, 29, 28 . . . 18, 17, 16

After day 15 should follow day 16/12 hours or 11 hours 12 minutes, and day 30 is again the New Moon with 0h 48m on the left side.

I am very anxious to know if this situation still exists and I thank you in anticipation of your reply.

ING J. T. H. C. SCHEPAN
Netherlands

EDITORS NOTE: The table of the moon's ages is discussed fully in the article on the Queens' College Dial in BSS Bulletin 94.3. It is correctly delineated as shown in M. Rohr's book, the table actually indicating from New Moon on day 1 and arriving at New Moon again on day 30. It must be confessed that the table is confusing, especially without indication of the day of the full moon. The table is arranged so that addition of the tabular figures only is required (no subtraction). Best to consult the clock dial conveniently placed above the sundial and floodlit at night.

THREE SHADOW LENGTHS

I was most interested to read J. G. Freeman's article for finding Latitude, Declination, and North from three, spaced shadow lengths of a vertical gnomon in Bulletin 93.3, page 23.

As a tyro in these matters I would like to ask two questions:

1. What happens to the formula

Declination - 90° - $\angle S_3$ OP when the declination is south?

2. What sort of accuracy does Professor Freeman think one can get from this procedure?

My own experience in finding Latitude from a shadow-stick at noon, knowing the sun's declination exactly, is that the accuracy depends very much on a bright sun giving a sharp tip to the shadow.

I would have thought that the more drawing one has to

do, as in Professor Freeman's method, would lead to a considerable loss of accuracy. I hope I am wrong.

C. D. LACK

THE CAPUCHIN DIAL AS AN EDUCATIONAL STUDY OF THE SPHERICAL TRIANGLE

The article by Frederick W. Sawyer III in Bulletin 94.3, October 1994 implies that the more general form of the Capuchin dial includes the Regiomontanus dial and which introduces a 'two-dimensional tridon'. These rather unfamiliar terms are apparently required to prepare the device for a given latitude and date. The description of this sundial is presented as a compromise between the simplicity of the Capuchin dial and the Regiomontanus dial universality.

It is generally acknowledged that the Capuchin dial is not simple either in its construction or use for ordinary diallists. It is, nevertheless, a dial of historical interest and one of great instructional and educational value for the following reasons:

It belongs to the type of sundial which is based on the Sun's altitude α , and on the date of the observation. This date fixes the Sun's declination δ . The trigonometrical relation which determines the Sun's Hour Angle and hence the solar local time, is:

$$\cos HA = \frac{\sin \alpha - \sin \delta}{\cos \phi \cos \delta}$$

This relation in action on the Capuchin dial elegantly demonstrates the essential geometry of this type of dial, as shown in Figure 1. The geometry of the Capuchin dial agrees with the spherical triangle formula calculation. This can be confirmed by a calculation using altitude $\alpha = 20^\circ$, declination $\delta = 6^\circ$ and latitude $\phi = 51^\circ$;

$$\text{so } \cos HA = \frac{\sin 20^\circ - \sin 6^\circ \sin 51^\circ}{\cos 6^\circ \cos 51^\circ}$$

giving $HA = 65^\circ.37$ (i.e. at $15^\circ = 1$ hour) = 4h 21m. Adding

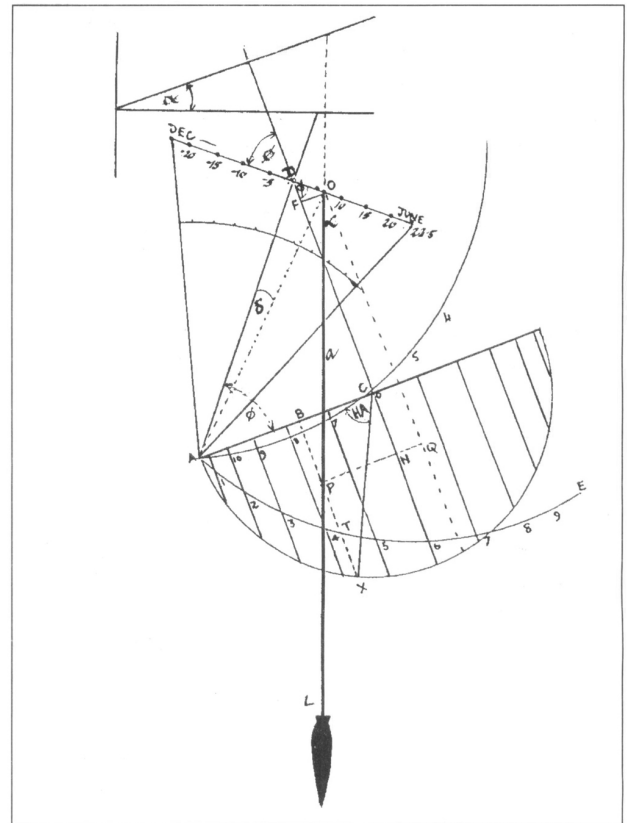

FIGURE 1: P is position of bead where: $OP = a = OA$

- $\cos HA = DN/CX$
- $PN = PQ - NQ$
- $PQ = A \sin \alpha$
- $NQ = D \sin \delta$
- $DO = a \sin \delta$

$CX = CA = D \cos \phi$ and $DA = a \cos \delta$ so:

$$\cos HA = \frac{a \sin \alpha - a \sin \delta \cdot \sin \phi}{a \cos \phi \cdot \cos \delta}$$

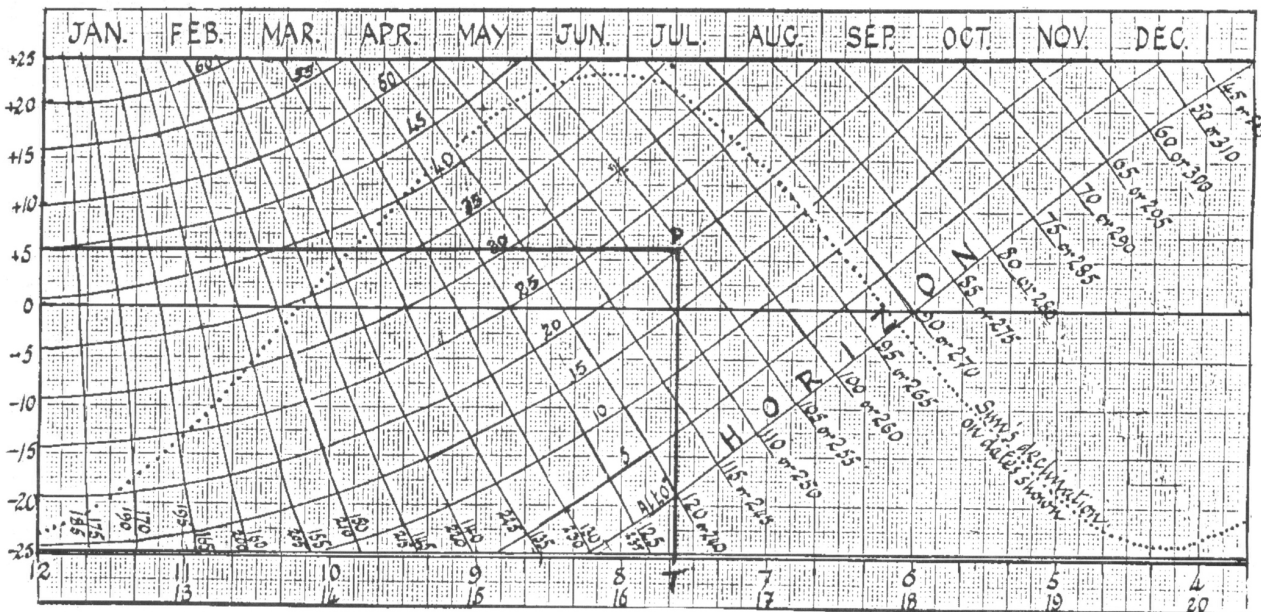

FIGURE 2: A SUN COMPASS AND SUN CLOCK

Latitude $51^\circ N$

1. Read the sun's declination for the date from the dotted curve.
2. Enter this declination on the Y axis.
3. Read the sun's altitude and azimuth from the graticule.
4. Read the Local Sun Time along the X axis.

12h for Sun time pm gives 16h 21m, or the am time 7h 39m. This corresponds with the time given by the bead P on the diagram of the dial.

It is of interest to check this time with the reading given by the intersection monogram show in Figure 2 which has been drawn for Latitude 51° , and shows solar time at the point T which is the intersection point having declination 6° and altitude 20° . This particular nomogram relates the Hour Angle, the Altitude, the Declination (and for good measure, the Azimuth) and is drawn from a computer printout based on the trigonometrical relation shown above.

The nomogram demonstrates that the Sun's Hour Angle can be obtained without knowledge of the declination by making use of the Sun's azimuth in combination with the altitude. In the example quoted, the azimuth is 106° for the morning time, and 254° for the afternoon time.

Note: GMT = Local SUN Time - E + Long West or - Long East. See Equation of Time graph. Atmospheric refraction causes the sun to rise about 5 minutes earlier and to set 5 minutes later than the times for the theoretical sun.

LOCAL SUN TIME

EXAMPLE: On May 1st the sun's declination is 14° , from the dotted graph. Observed alt. of sun 30° . From the graphs the Sun Time is 0805 and its Az. 106° or Sun Time 1555 and Az. 254° . The 14° declination line intersects the horizon curve showing sunrise at 0450, Az. 68° , and sunset at 1910 hrs. Az. 292° . For declination 6° and altitude 20° , latitude $\phi = 57$, Sun Time 7h 39m am or 16h 21m pm.

H. R. MILLS

TIDAL DIAL

You had the kindness to publish my article "A Tidal Dial" in BSS No. 92/2.

The revue "Seine Marine" asked me about the subject and rather than give the French version, I have given to them a more adapted text to seamen and also more complete.

I have read with interest your article in BSS Bulletin 94.3 "The Queens' College Dial", particularly about "Longitude" which you translate by the "duration of the day", but the Latin word excuses Mr. Shephard's error.* The design of these hours is so curious (120 for 12) that I believed they were degrees and consequently longitude of the sun and not the right ascension. I found other corrections than those proposed by Mr. Shephard! May I ask you a Rank Xerox of Scarr's pamphlet?

About your paragraph "The Mood Dial", I suppose we must read at page 5 (right and left) "the same amount must be added" at the place of "deducted". I think it is an error of print or I have nothing understood . . .

Personally, I prefer to add the initial connection and consider that days are those after the New Moon. More simple yet is the M. Rohr's design page 132 in his 1986 edition "Les Cadrans Solaries" and your proposition confirms it.

Bravo for the BSS and its Bulletin - Thank you for your work.

With best regards.

DENIS SCHNEIDER
France

*Munster wrote "Quantitor diai" in 1531.

LITTLE SHIP OF VENICE

There is in England a magazine devoted to sundials and you belong to the editorial staff. I would like to subscribe to your magazine and would be pleased if you would inform me by letter:

- The magazine's name, number of pages and issues each year.
- The yearly subscription rate and cost of despatch to Italy.
- The payment terms of the magazine.

ING ENRICO DEL FAVERO
Italy

P.S. I enclose a postcard illustrating one of the two hundred sundials which are held in the private museum "Poldi Pezzoli" in Milan.

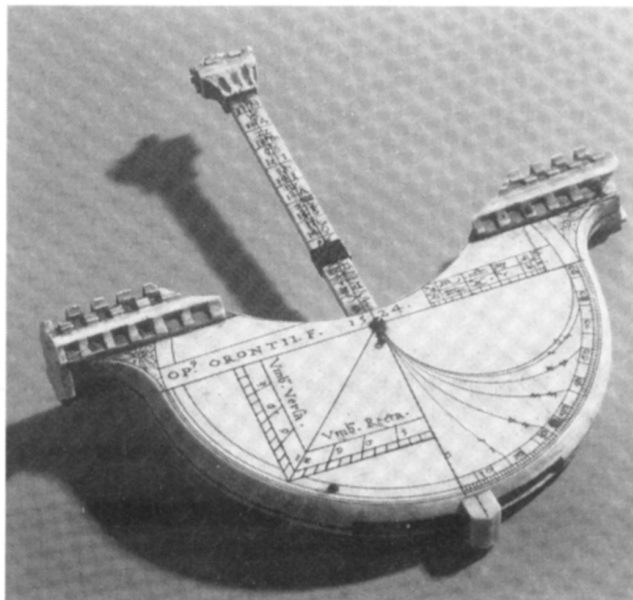

EDITOR'S NOTE: I visited the Poldi Pezzoli Museum in 1973, just before it was officially opened. The horological exhibits are absolutely splendid, and what could be nicer than the Little Ship of Venice (Navicula de Venetiis) sundial depicted here? It is signed by Oronce Finé, and dated 1524. It is made from ivory and is in remarkably good condition.

To remind members - the subscription rate is £18.00 for membership, and £20 for family membership but the family member does not have a copy of the BSS Bulletin. There is a charge for the extra postal costs for despatch to overseas countries, for details contact the Membership Secretary. Mr. Robert Sylvester, address on the inside of the back cover. Since receiving this letter I have been looking for the rest of the editorial staff to inform them, but without success.

BOOK REVIEWS

A CELEBRATION OF CORNISH SUN DIALS, Carolyn Martin, pp. 48, 18 b & w illustrations, mostly by Tessa Fearnley, 21 x 15 cm, thin card covers, illustration on front cover by Jonathan Statham based on the sundial at St. Columb Minor, 1994. Published by Cornish Publications, Dyllansow Truran, Trewolsta, Trewirgie Hill, Redruth. ISBN 1 85022 071 9, Price £3.50.

This is a pleasant little sundial book from our member Carolyn Martin, consisting of an Introduction to sundials in Cornwall, Sundial Furniture, Search and Research, Directory of sundials in Cornwall, a short history of sundials, types of dials, the mathematics of dialling and making of a simple sundial, a short piece on modern dials, ending with short notes on the British Sundial Society, sundial manufacturers in the West Country and a bibliography.

It is eminently suitable for an introduction to the dials of Cornwall and is written so that anyone, even without a knowledge of dialling, can read its contents with pleasure.

CHARLES K. AKED

SUNDIALS - A BEGINNER'S GUIDE, Bob Kiddle, pp. 14, 30 b & w illustrations, A4 photocopy pamphlet. 1994, published by the author. Price not known. Enquiries - please telephone 0171 274 0530.

The cover states "A Synthesis of Design, History, Astronomy and Architecture it (the Sundial) is the perfect context for cross-curricular explorations. Use this guide to make one for your home or school".

This is truly a beginner's guide, written by someone who still counts himself a novice in the art of dialling and therefore still familiar with the problems met by those wishing to make their own sundial for the first time.

The contents of this little guide are:

- Introduction
- Dials - Equatorial, Horizontal, Vertical, Declining and Miscellaneous
- Local Solar and Mean Time
- Two Appendices - giving information on examples

The information is given in a very open and clear style which is suitable for the absolute beginner or for the younger student. Since the guide was obtained it has been amended, in the review copy statements are included such as:

"Horizontal dials are simple to construct because they

need be oriented to north on any horizontal surface". The reviewer fails to see the logic in this. Again, in the chapter - Local Mean Time - the last sentence reads - "So during BST all sundials are automatically one hour slow". Really?

These small blemishes are mentioned merely to let the reader know that the reviewer has read the pamphlet. For schools this is a good guide for students to gain basic dialling knowledge.

MALTESE SUNDIALS, Paul I. Micallef, pp. 125, 60 b & w plates. 20.5 x 14 cm., thin card covers, coloured illustration front cover, 1994. Price not supplied. Available from Sapienzan Bookshop, Republic Street, Valletta, Malta.

The Preface to this outlines the purpose of the book in recording the sundials in the Maltese Islands, amplified by the Introduction and a little history which includes the revision of the Calendar to the Gregorian in 1582 (in Malta).

Pages 12-15 give short biographical notes on designers of sundials. Included are Castronius, Father Calcedonius, Reverend George Fenech, Charles G. Zammit, H.R. Lee, and the author Paul I. Micallef.

Pages 16-113 contain the actual examples of sundials in alphabetical sequence, the left hand page showing a full page photograph, opposite each is a brief note giving location, description and the name of the designer (where known). That of Rabat, a vertical dial with analemmatic hour lines, designed by the Reverend George Fenech in 1984, provides the front cover illustration.

Two Appendixes give some further photographs which could not be placed in the main listing. There are only captions in explanation, where some text should have been provided. There is also a page taken from an 18th century manuscript on sundial design preserved in the National Library of Valletta on page 6, and a listing of 16 bibliographical references on page 124 which brings the book to a close.

The photography by Charles Fava is competently done, so the book is an excellent reference source for details on Maltese Sundials. The book employs perfect binding and suffers from not being able to be opened flat, plus the normal curving covers after opening. As most of the textual pages are only partially used, it would have been far better to have had a wider margin on the left so the words could be read easily instead of having to be dug out of the centre fold which cannot be fully opened.

CHARLES K. AKED

FROM STRETCH DIAL TO THE DOUBLE HELIX

JOHN MOIR

No, there are no misprints in the above title - I hope not anyway! The Stretch (as opposed to Scratch) and the Double Helix dials are simply two concepts which arose out of my strong desire to understand the workings and mathematics, such as they may be, of helical (twist) dials, believing they must be incredibly complex.

I first turned to an article by Allan Mills in BSS Bulletin 92.2 in which he explains the workings of the Piet Hein helical dial. He points out that both edges of the helix act as gnomons, and both surfaces as receiving planes for the cast shadows. Fig 2a shows the 12 o'clock shadows on such a dial. The shadow boundaries "climb up" the axis with the rotation of the sun about that axis at a rate of 15 degrees per hour. (As a useful analogy, I compare it to an Archimedean screw which lifts shadows instead of liquid or grain).

In my enthusiasm to make one, and observe it in operation as soon as possible, I decided that twisting a piece of metal accurately would take me forever and/or cost me the earth. There had to be another way - and there it was. I would use elastic strip, in some ways it would be superior to twisted metal in that my material would "give", and thus accommodate distortion more successfully.

CONSTRUCTION

The elastic I needed was a larger version of that utilised, with varying degrees of effectiveness, is preventing boys' socks and undergarments in general from descending at unwanted moments.

I obtained my one and a half inch elastic strip by raiding my wife's work basket, (I do like to involve her as much as possible in my hobby!). The frame to support the

elastic strip was obtained by cutting off a slice of twelve inch diameter yellow plastic gas pipe, carelessly thrown away in the vicinity of my house by the fitters. Figure 1 shows the finished dial, produced at no cost after all of three hours work.

As the photograph shows, the ends of the band are gripped in slits in the plastic and both these ends and the mid-point of the strip lie in the meridian plane. Before assembly, the elastic strip was stretched out, pinned it to a drawing board and marked out with the twelve hour divisions (each $1/24$ of the helix) from 6 to 6, which of course, lie at $1/4$ and $3/4$ of the helix length respectively. This was then repeated on the reverse side and the band slotted into its carrier, giving it a 360° left-handed twist. As Allan Mills points out, this 12 hour calibration is all that is needed, for when the summer sun goes off the upper 6 hour mark, the shadow of the lower 6 hour mark takes over, so that 7, for example, would then stand for 7 pm, having served duty as 7 am 12 hours earlier.

I was now ready to test out the behaviour of my creation in action, and since the autumn equinox was approaching I would be starting off with what I suspected was the simple situation, the sun's rays being at right-angles to the helix angle.

OBSERVATIONS

As Fig 2a shows, at the equinox, the shadow boundary at noon lies squarely through the noon mark. However, when viewed from the West the shadow lies above the hour mark, and when viewed from the East it lies below the hour mark. This reversal is a fascinating feature of this type of dial.

I now wanted to see what happened at a solstice position, and reluctant to wait three months, I simulated this by tilting the dial, at noon, through $23\frac{1}{2}$ degrees North and South. Hereafter all my comments apply to the noon readings, although of course the effects described "translate" to any time of day. Figure 2b shows the shadow effects as seen from West and East at the winter solstice. When viewed from the West, two changes were noted:

1. The boundary line, although still passing through the noon mark (as far as could be judged), was not perpendicular to the axis but angled towards the sun.
2. The boundary mark was less distinct than before.

When viewed from the East, the following effects were noted:

3. The boundary line was again roughly at right angles to the axis but was displaced to approximately 12.25 pm.
4. The line was now more distinct than in 2a, the equinox situation.

Figure 2c shows the summer solstice position where all the above effects apply, but to the reverse face, and the displacement, as in 3 above, is now from 12 to 11.35 am approximately.

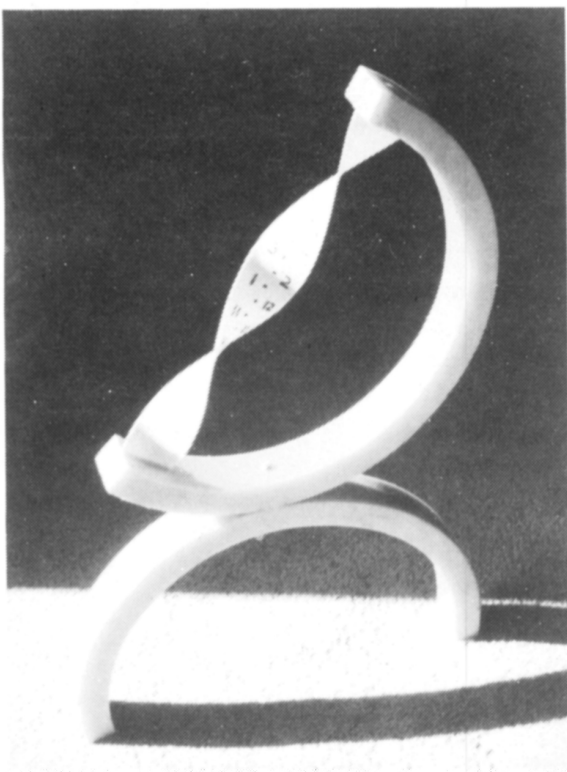

FIGURE 1: Stretch Dial

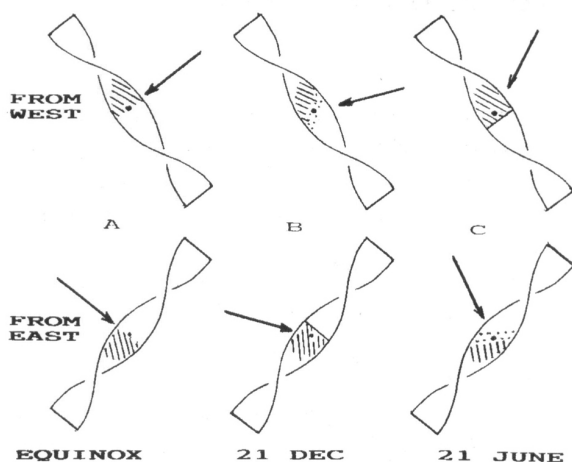

FIGURE 2: Shadows cast on helical strip at Equinox, 21st December and 21st June, viewed from West and East

CONCLUSIONS

An analysis of the above observations can perhaps best be undertaken by journeying through time from 21st December to 21st June, looking only at the west side for simplicity. The first remarkable discovery is that on 21st December, the edge is not acting as a gnomon at all! The shadow boundary here is simply an indistinct division between lit and unlit areas, familiar to moon-watches as the “terminator”). In topological terms, the surface on which the light impinges here is in the form of a “saddle”, whose shape causes the shadow boundary to be indistinct and angled towards the sun, see Fig 2b upper). As we continue towards the equinox, the shadow boundary becomes a little more distinct and less angled towards the sun, until when the equinox is reached, it is again perpendicular to the axis, see Fig 2a.

The equinox is a sort of pivotal point since it is only after 21st March that the leading edge starts to act as a gnomon, thus providing, the first time a sharp boundary line. Also, as the sun climbs higher in the sky, the boundary line is correspondingly projected forward until at 21st June, the maximum displacement occurs (Fig 2c upper).

A similar journey in time, looking at the East side of the dial would show all the above effects but in reverse order of occurrence. In all, I had observed some most unexpected shadow effects and seen that they were the result of complex geometric relationships, but I doubt whether these

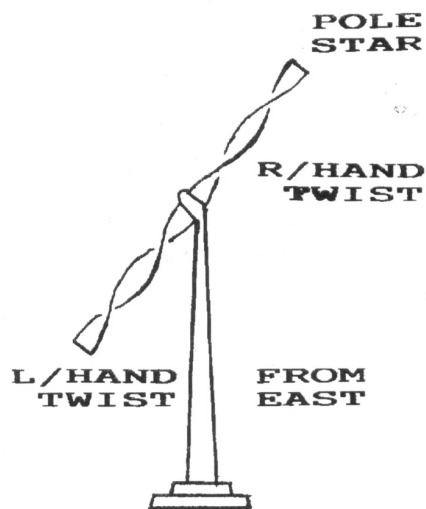

FIGURE 3: Double Helix Sundial

would be amenable to a mathematical analysis (the displacement effect in particular), though I wait to be proved incorrect! With hindsight, it is easy to see that these “unexpected” shadow effects are not surprising at all, they result inevitably from the asymmetrical form of the helix.

At this point I refer to Fig 3 which shows my solution to the problem - the “Double Helix”. Such a dial combines a left-handed helix with an identical but right-handed helix, thus creating an overall symmetry, which can be exploited as follows:

The upper, right-handed helix is calibrated from 6 at the top downwards, whereas the lower left-hand helix runs from 6 upwards. Ignoring the fuzzy boundaries, which may be difficult to determine accurately, one would simply observe the respective sharp boundaries. If one reads fast, the other must read equally slow, and the average must always give a correct indication!

Finally, I would like to hear from anyone who decides to make such a dial, or has any comments to make on the points made here.

POSTSCRIPT

I must add that I have not intended in any way to criticise the Piet Hein dial, which, if not the most accurate of sundials is, for me at least, the most intriguing. Its inspired form deserves to be seen and appreciated more widely.

BSS SUNDIAL COMPUTER PROGRAM

Mr. F.J. de Vries has kindly provided an extension to the dialling program which allows the results to be printed out on printers such as Canon, Epson, Fujitsu, HP, IBM, JRL, NEC, Toshiba (9 or 24 pin), Laser, etc. Mr. de Vries actually uses a Canon bubblejet printer in the Epson 24 pin mode and says he gets good results from this. If you have a colour printer, this can be used also.

Thanks to the kindness of Mr. J. McCrindle, the program is now available on two 3½" discs. The price is

still £8.50 for the program and despatch costs; those who purchased the original program may update for the price of £2.50 (to cover the cost of the discs and postage) on return of the old disc as proof of the initial purchase. There is no objection of copying the original program for continued personal use.

The Editor, on behalf of the BSS members, thanks both Mr. de Vries and Mr. McCrindle for their assistance in providing the program for BSS members.

DECLINATION FINDER

RAY ASHLEY

In order to calculate accurately and set up a vertical sundial, the declination of the wall to which it is to be fixed must first be measured. A number of ways are described in most books on sundials and involve a board with either a vertical pin or a plumbline which requires still air in which to get a reading.

An accurate result depends on eliminating errors as much as possible and an instrument I have designed, does this, enabling an accurate instantaneous measurement to be made at the moment the sun souths. Measurements can be taken at other times and the declination calculated mathematically.

The measuring device consists of two parts.

PART 1

For the base, I used a piece of $\frac{3}{4}$ " MDF 12" x 12", drilled to take 3 feet, one fixed and two adjustable for levelling. MDF can be drilled and tapped to take machine screws or alternatively clearance holes can be drilled and nuts and screws used for adjustment.

A centre line is accurately drawn perpendicular to the edge that will be placed against the wall to be checked. This line is the datum line and a small pin should be fixed at the centre of the line protruding about 12 mm above the board.

PART 2

A disc $4\frac{1}{2}$ " diameter is cut from $\frac{3}{4}$ " MDF and 3 small holes drilled on the centre line, one at the centre and one each side about 6 mm from the edge. The centre hole should be about 14 mm deep and should not go right through.

A 360° protractor is fixed to the disc so that both centres coincide. The centre line of the disc and the 360°-180° line of the protractor should also coincide. The protractor is fixed to the disc by drilling and countersinking two holes and screwing it to the disc.

When the disc is set on the pivot on the base board, the centre line of the protractor should lie on the datum line.

A small pin is fitted in one of the outer holes in the disc and cut to protrude about 1mm above the board and another pin should be fitted into the other hole sticking up about 150 mm both pins should be a good fit in the holes but is a good idea if the long pin can be taken out for protection when it is not in use, as it is important that it is straight and truly vertical when in use.

TO FIND THE DECLINATION OF A WALL

The device is placed against the wall to be measured and levelled using a spirit level on two

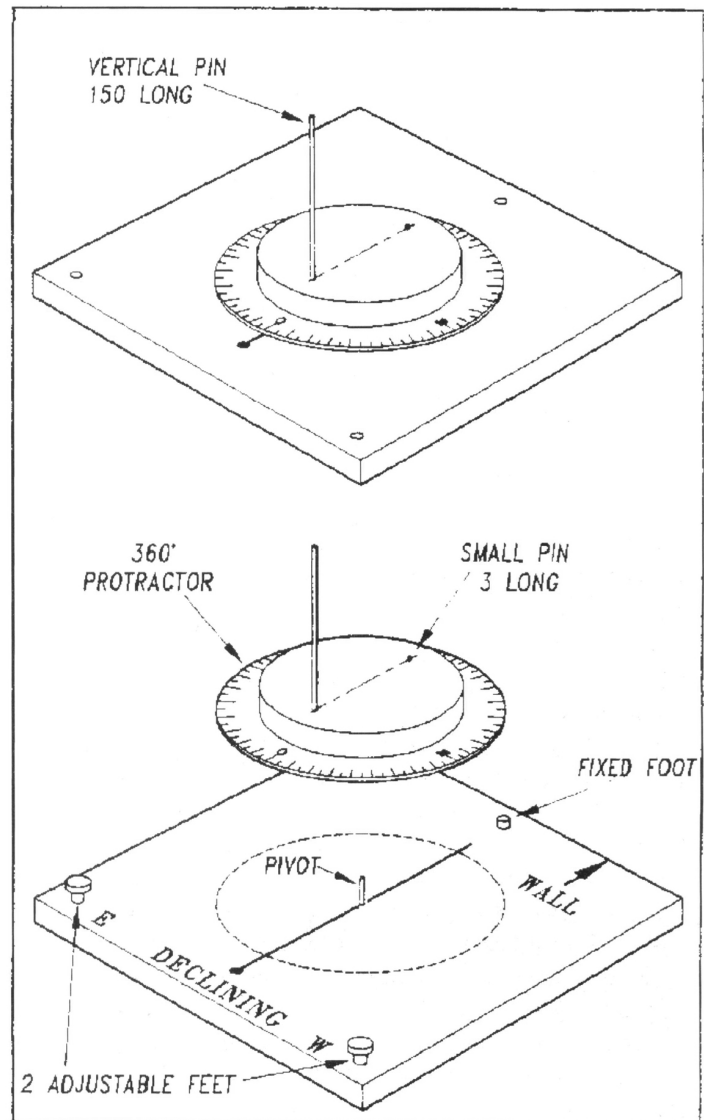

Declination Calculator
Dimensions in millimetres

axes, and the disc set so that the centre line of the protractor is in line with the datum line on the base board. The pins should lie perpendicular to the wall with the longest pin farthest away.

The shadow of the longest pin will fall across the disc. At the moment that the sun souths, rotate the disc so that the shadow falls over the small pin. The angle turned can be read at the datum line and this will give the declination of the wall.

The wall declines east of south if the disc has moved to the left and west of south if the disc has moved to the right.

My dimensions are not critical, accurate construction being more important.

NOTE: MDF = Medium Density Fibreboard.

THE SCIENTIFIC INSTRUMENT SOCIETY

The Society was formed in 1983 to bring together people with an enthusiasm for scientific instruments. Members' interests span from the earliest known instruments of antiquity through to those of the present century. They include Collectors, Dealers from the Antique Trade, Museum Staff, Academics and other enthusiasts, all with an interest in instruments and the skills used in their manufacture.

A high quality Bulletin is published four times each year. It contains a wide range of articles by members as well as book reviews, exhibition news, details of meetings and general activities. Its advertising section keeps members up to date with the activities of the auction houses and dealers' stock.

The Society holds regular meetings, mostly in London. These meetings often include a museum visit and usually one or more short talks on a specific topic.

The highlight is the annual foreign visit, each year to a different country, to explore its museums and sights. During these visits, the members are usually taken behind the scenes and are able to study reserve collections at first hand. In many instances, the precious exhibits are available for members to handle and photograph.

The Society is also setting out on a programme of publishing Monographs from acknowledged experts in their various fields. These monographs are destined to become

standard works in their subject.

Many of the interests of the SIS and the BSS overlap and already there are several members in both societies. Sundials form only part of the SIS activities and usually the emphasis is on the portable dials produced from 16th century onwards. A number of members also have a keen interest in the sundial's big brother, the astrolabe.

Most sundial makers were general scientific instrument makers and their dials were just one item from the wide range of scientific, mathematical and philosophical instruments that they produced. When looking for sundial makers, reference to lists of scientific instrument makers will frequently prove rewarding. Otherwise they will often be found from the clockmakers of that period.

The Scientific Instrument Society extends a warm welcome to all members of the BSS to attend many of its meetings. Details of these meetings will generally be found in the BSS Bulletin.

For membership please write to:

The Scientific Instrument Society,
31 High Street, Stanford in the Vale,
Faringdon, Oxford, SN7 8LH.

Annual membership fees are £30 UK and £35 Overseas.

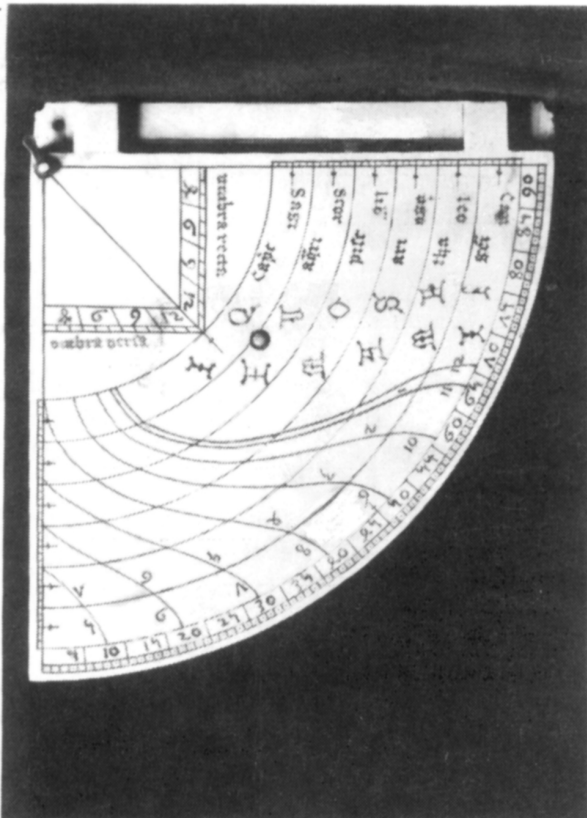

FIGURE 1: A Quadrant once owned by the Kaiser Friedrichs III, now in the Kuntsthistorisches Museum in Vienna.

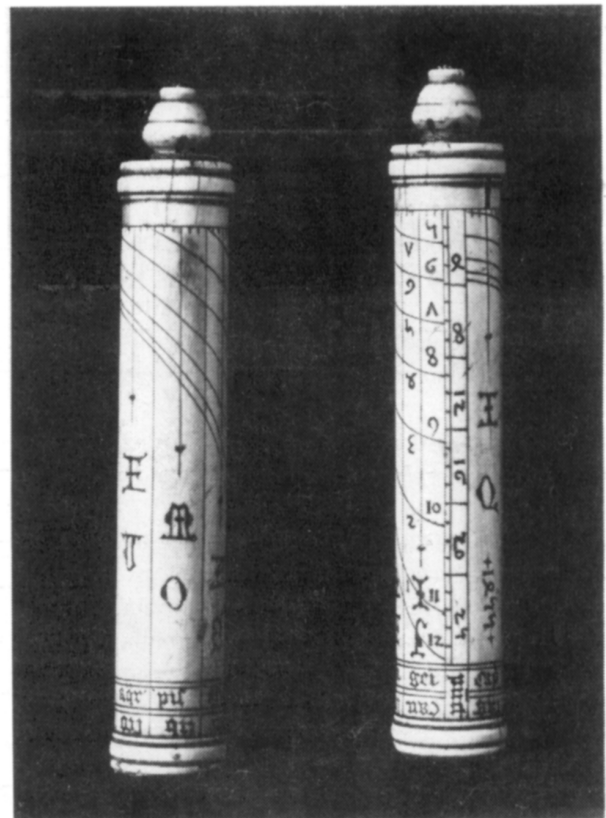

FIGURE 2: Two views of an ivory Column Sundial dated 1685.

USEFUL ADDRESSES

Mr. Charles K. Aked
54 Swan Road
WEST DRAYTON
Middlesex UB7 7JZ

[Editor]
Tel: 01895 445332

Mr. Robert B. Sylvester
Barncroft
Grizebeck
KIRKBY-IN-FURNESS
Cumbria LA17 7XJ

[Membership]
Tel: 01229 889716

Mr. C. St. J.H. Daniel
57 Gossage Road
PLUMSTEAD COMMON
London SE18 1NQ

[Chairman]
Tel: 0181 3178779

Mrs. Jane Walker
31 Longdown Road
Little Sandhurst
CAMBERLEY
Surrey GU17 8QG

[Education]
Tel: 01344 772569

Mr. E.R. Martin
West Lodge
Thicknall Lane
CLENT
Nr. Stourbridge
Worcs DY9 0HJ

[Mass Dials]
Tel: 01562 882709

Miss R. J. Wilson
Hart Croft
14 Pear Tree Close
CHIPPING CAMPDEN
Gloucestershire GL55 6DB

[Council Member]
Tel: 01386 841007

Mr. R.A. Nicholls
45 Hound Street
SHERBORNE
Dorset DT9 3AB

[Treasurer]
Tel: 01935 812544

Dr. I.D.P. Wootton
Cariad Cottage
Cleeve Road
GORING-ON-THAMES
Oxon RG8 9BD

[Registrar]
Tel: 01491 873050

Mr. P. Nicholson
9 Lynwood Avenue
EPSOM
Surrey KT17 4LQ

[Sponsorship]
Tel: 0137 27 25742

Mr. D.A. Young
Brook Cottage
112 Whitehall Road
CHINGFORD
London E4 6DW

[Secretary]
Tel: 0181 529 4880

Mr. Alan Smith
21 Parr Fold
WORSLEY
Manchester M28 4EJ

[Northern Liaison]
Tel: 0161 790 3391

Mrs. Anne Somerville
Mendota
Middlewood Road
HIGHER POYNTON
Cheshire SK12 1TX

[Library, Archival
Records & Sales]
Tel: 01625 872943