

# Textural Modification of Processing Tomatoes

Diane M. Barrett,\* Elisabeth Garcia, and Jo Ellen Wayne\*\*

Department of Food Science & Technology, University of California, Davis, California 95616–8598

\* Author to whom correspondence should be addressed.

\*\* Current position is with: Quest International, Silverton, Oregon 97381.

Referee: Professor Malcolm C. Bourne, Food Research Laboratory, Geneva, New York 14456–0462

**ABSTRACT:** Knowledge of the textural properties of processing tomatoes is crucial to ensuing product acceptability; measurement, control, and optimization of these properties through judicious selection of varieties and control of unit operations results in products that the consumer prefers. It is important to first define the terms texture, rheology, consistency, and viscosity prior to discussing principles of their measurement. The textural properties of processing tomatoes may be measured using both sensory and objective tests, and the latter may be either destructive or nondestructive in nature. The unique anatomy of tomato fruit (peel, pericarp, columella, and locules) in part dictates the method of texture measurement. Numerous factors, including variety, maturity, genetic modification, cultural particles, and environmental conditions, processing conditions, and calcium addition affect the textural integrity of tomatoes. Textural properties of raw tomatoes and most processed tomato products are reviewed in this article.

**KEY WORDS:** textural properties, rheology, viscosity, tomatoes, processed, sensory, objective.

## I. INTRODUCTION

Tomatoes are unique fruit vegetables composed of varied types of tissues that play a critical role in the perception of texture. Tomato products represent an increasing proportion of the U.S. diet and provide an essential source of Vitamin C, potassium, and antioxidants (primarily lycopene). Two-thirds of the total world production of tomatoes is processed (Johannessen, 1993), and application of thermal preservation treatments significantly affects product firmness, viscosity, and consistency. California produced 93% of the U.S. processing tomato volume in 1994 (USDA, 1971), and it is estimated that 60 to 65% of the world production of processing tomatoes is concentrated in California and Italy (Hobson and Grierson, 1993). The objective of the review is to briefly discuss textural properties and tomato biology, review sensory and objective methods of measuring texture, and evaluate the textural properties of raw tomatoes and processed tomato products.

## II. TEXTURAL PROPERTIES, VISCOSITY, AND CONSISTENCY

According to Bourne (Bourne, 1982), the *textural properties* of a food are the “group of physical characteristics that arise from the structural elements of the food are sensed by the feeling of touch, are related to the deformation, disintegration, and flow of the food under a force, and are measured objectively by functions of mass, time, and distance”. The terms texture, rheology, consistency, and viscosity are often used interchangeably, despite the fact that they describe properties that are somewhat different. In practice the term texture is used primarily with reference to solid or semi-solid foods such as whole peeled and diced tomatoes, rather than liquids. *Rheology* may be defined as the study of deformation and flow of matter or the response of materials to stress (Bourne, 1993). Rheology is a science that involves evaluation of foods and other materials that are both solid (do not flow) and liquid (flow).

*Consistency* refers to non-Newtonian fluids or semi-solids (sauces, purees, pastes) with suspended particles and dissolved long chain molecules. The term *viscosity* is used primarily to describe liquid foods such as tomato juice and is defined as “the internal friction of a fluid or its tendency to resist flow” (Bourne, 1982). Viscosity and consistency differ from texture in that the latter typically requires forces greater than gravity to effect flow or deformation. Raw and processed tomatoes may be described in terms of their general rheological or textural properties, which include consistency and viscosity.

Although the term texture generally applies to solids and semi-solids and viscosity to liquids, very few foods are strictly solid or liquid in nature. Most foods are *viscoelastic*, implying that they exhibit combined properties of ideal liquids, which demonstrate only viscosity (flow), and ideal solids, which exhibit only elasticity (deformation). Tomatoes, for example, are typical of plant materials which contain a significant amount of water and other liquid-soluble materials surrounded by semi-solid cell wall and pectic middle lamella materials. In addition, plant materials contain a certain amount of gas dispersed both intra- and intercellularly. Tomatoes are approximately 93 to 95% water and 5 to 7% total solids, the latter comprised of roughly 80 to 90% soluble and 10 to 20% insoluble solids (Wolcott, 1982). The greatest contributor to the consistency of tomato products are the insoluble solids.

U.S. Standards of Identity for various tomato products loosely define consistency with reference to fluid or semisolid products as “the viscosity of the product and the tendency to hold its liquid portion in suspension” (Gould, 1992). Observations of free liquid separation and flow in a Bostwick consistometer are the specific indices utilized for the consistency of fluid and semi-solid products. Standards of identity for solid tomato products such as canned whole peeled and diced tomatoes define another textural property, character, as the “degree of firmness normally found when tomatoes have been processed using good manufacturing practices” (Gould, 1992). Cooked tomato products that are excessively soft or mushy are considered lacking in character. Excessively soft products are further defined as

meaning that “the unit may disintegrate upon handling, has evidence of sloughing or has ragged edges, and has lost ability to hold its shape.”

Knowledge of textural properties of processed tomatoes is crucial to ensure product acceptability; their measurement, control, and optimization through judicious selection of varieties and control of unit operations will result in products that the consumer prefers. Many tomato processors interested in producing high-quality products have implemented company standards that go above and beyond those specified by the U.S. Department of Agriculture.

### III. PRINCIPLES OF MEASUREMENT OF TEXTURAL PROPERTIES OF TOMATOES

Textural properties may serve as an indicator of maturity or processability to the food processor and of eating quality to the consumer. The measurement of tomato texture is not as straightforward as one might imagine, in part because of the number and diversity of physical and sensory properties falling under the designation of texture and in part because of the discontinuous and varied nature of tomato tissues themselves. The measurement of textural properties may employ either objective or sensory evaluation or preferably a combination of the two, and may be accompanied by an evaluation of tomato microstructure. In order to predict consumer response to texture via objective tests, one must first correlate sensory evaluation results with the results of objective tests (Bourne, 1979). Procedures for sensory analysis of textural properties, the principles of objective texture tests (nondestructive and destructive) and the correlation of these two important types of evaluation is reviewed.

#### A. Sensory Analysis

The sensory perception of textural properties occurs directly through the tactile (touch) and kinesthetic (movement) senses and indirectly through the senses of vision and hearing (Bourne, 1993). Unlike color and flavor, humans do not

have specific sensory receptors for texture. Texture sensations may be organized into (Szczeniak et al., 1963; Bourne, 1993): mechanical characteristics (reaction of the food to stress), geometrical characteristics (feeling of the size, shape and arrangements of food particles), and other characteristics (relating to the sensations of moisture, fat and oil in the mouth).

Based on the structural integrity of horticultural tissues, consumers usually describe fruit and vegetable products as either “juicy” or “pulpy” (Bourne, 1983). In unripe tissues where the middle lamella is strong and rupture occurs through cell walls, biting into the product releases cell contents into the mouth and a juicy sensation results. In senescent or processed tissues the middle lamella is weakened and a mixture of crushed cells, juice, and soft cell wall parts are released on biting, imparting a pulpy sensation.

Methods used to evaluate changes in texture typically fall into three general categories: difference; preference, including relative-to-ideal, and attribute methods (Jack et al., 1995). In recent years, the development of the sensory texture profile has afforded scientists with a more comprehensive technique for measurement of the textural properties of foods. In this method, a panel is trained using reference standards to scale and quantitatively measure all of the textural properties experienced during complete mastication of the food. Using a trained descriptive panel, our laboratory recently collaborated with sensory scientists on generation of a list of tomato texture descriptors (Table 1) for diced tomatoes.

Sensory tests are typically destructive and empirical, although methods that involve a gentle squeeze between the fingers and do not involve measurable deformation may be considered non-destructive. Voisey (Voisey and Crete, 1973) developed a method for measuring the force and application rate by which untrained males and females squeezed fruits and vegetables with the fingers. It was noted that the way in which a product was squeezed appeared to provide a personality index and that individual panelists were very consistent. The panel as a whole, however, showed quite a bit of variability, with the variation in rate of force application being even higher than that in the applied force. Panel variability for

rate of force application on tomatoes ranged from 1456 to 95,568 g/s in females and 1536 to 14,392 g/s for males.

## B. Objective Measurement

Instrumental or objective methods of texture evaluation can be grouped into three classes (Szczeniak et al., 1963): fundamental, empirical, and imitative tests. Fundamental tests measure properties that are familiar to engineers (e.g., strength, Poisson’s ratio, and various moduli such as Young’s modulus, Shear modulus, and Bulk modulus [Bourne, 1978]). Fundamental tests may correlate poorly to sensory judgments, and they are limited in that they measure only one property of what is typically a multiparameter attribute (Bourne, 1994).

Empirical tests cover a wide range of simple and rapid tests, including puncture, compression, extrusion, shear, and others, which measure one or more textural properties and are commonly used in quality control applications (Bourne, 1994). Experience teaches us that these types of tests correlate well with sensory judgments, but we usually have little or no fundamental understanding of the test. Most methods used for evaluation of the textural properties of tomatoes are empirical or semiempirical, in part due to the operational difficulties inherent to texture measurements, but also because of the nonhomogeneous, discontinuous, and anisotropic nature of tomatoes themselves (Jackman, 1995).

Finally, imitative tests are those that utilize instruments in an attempt to mimic what occurs in the mouth as the food is masticated. In many cases, results from imitative tests also correlate well with sensory judgments, but again we may not have fundamental knowledge of the test principles. In choosing an objective test for measuring textural properties, one must first determine which specific textural properties are of interest, then evaluate which objective test(s) will best measure those properties, and finally correlate results to sensory analysis prior to predicting consumer response.

The most commonly used methods for the evaluation of textural properties are those that

**TABLE 1**  
**Descriptive Panel Ballot for Diced Tomatoes**

Attributes	Directions	To assess...	1	2	3	4	5	6
Saltiness	Move sample around mouth before chewing	Saltiness of samples						
Acidity	Move sample around mouth before chewing	Acidity of samples						
Sweetness	Move sample around mouth before chewing	Aweetness of samples						
Slimy	Move sample around mouth before chewing	Amount of firmness and viscous feeling around the mouth						
Mushy	Press sample against palate	Whether sample breaks down						
Grainy	Rub sample against palate	Amount of particulate (also roughness produced by particulates) feel on palate						
Chunky (5 = more chunks)	Press sample against palate	The amount of chunks of tomatoes present (both visual and by mouth)						
Juicy	Chew sample 3 times between molars	Amount of juice released after chewing						
Crunchy	Chew sample 3 times between molars	Loudness a sample makes						
Seedy	Chew sample 3 times between molars	Amount of seed cracks						
Rubbery	Chew sample 5 times between molars	Amount of resistance a sample gives						
Fibrous	Chew sample 10 times between molars	Amount of fiber network leaves behind						
Ease of swallowing	Chew sample 5 times between molars, then swallow (0 = easy; 5 = hard)	Smoothness that sample gives while swallowing						
Sample consistency/homogeneity	Take 1 spoonful of sample; compare overall texture consistency both in mouth and visually (0 = inconsistent; 5 = consistent)	Compare the texture among tomato pieces						
Firmness/hardness	(5 = very firm)	Firmness/hardness of the tomato pieces						

*Note:* Procedure:

1. A half-spoonful of tomato sample will be used to rate the samples.
2. Rate samples across groups of attributes.
3. Rinse two (2) times between samples.
4. Use a scale of 0 to 5 to rate (0 = none to 5 = pronounced).

apply large deforming forces (e.g., via puncture or compression) and are therefore destructive. Because of the empirical nature of these tests, however, they do not provide us with an understanding of food microstructure or force-deformation and failure mechanisms at the cellular level (Jackman and Stanley, 1992). Recently, there has been a resurgence of interest in nondestructive tests that rely on well-defined fundamental principles and thereby may provide a better understanding of tomato tissue microstructure and the forces that lead to tissue failure. Both destructive and nondestructive tests are described below.

### 1. Destructive Tests

Bourne has reviewed objective methods for measuring textural properties of foods (Bourne, 1966); Bourne, 1980; Bourne, 1993) and classified them on the basis of the variable(s) being measured (e.g., force, distance, time, energy, ratio, multiple, chemical, and miscellaneous). The primary difference in the force-measuring instruments is the geometry of the test cell that holds the sample and applies a force to it (puncture, compression, shear, extrusion, etc.) (Bourne, 1993). Szczesniak and Bourne (1969) stated that with soft foods texture is generally measured by a viscosity test, with foods of intermediate firmness by a deformation test, foods of high firmness by puncture, and those of very high firmness by

bending. In most cases solid food is subjected to tensile, compressive, or shear stress (force per unit area), resulting in a change in dimensions such as length and strain (unit change due to stress) (Jackman, 1995). Stress is a function of not only force but also the rate at which it is applied and generally stress increases with application rate. The texture of horticultural products in particular is typically evaluated using one of the destructive methods listed in Table 2.

#### a. Puncture

The puncture test, which is a force measuring method that has the dimensions mass, length, and time, is probably the most frequently used method for textural evaluation. It consists of measuring the force and/or deformation required to push a probe or punch into a food to a depth that causes irreversible damage or failure (Jackman, 1995). The photograph (Figure 1) illustrates use of a 5-mm flat head stainless steel cylindrical probe to measure maximum force required to penetrate a tomato pericarp disk. Puncture force depends on two different properties of the sample (e.g., compressive and shear strengths) and on both the probe area and perimeter.

Convenient, hand-held puncture or pressure testers have been used by horticulturists in the field and laboratory for many years. Puncture probes of a specific diameter may also be easily fitted to laboratory scale instruments such as the

**TABLE 2**  
**Destructive Methods Used for Evaluation of Horticultural Crop Texture**

1. Force measuring
  - a. Puncture, e.g., Magness-Taylor Pressure Tester, Maturometer
  - b. Extrusion, e.g., Shear Press, Tenderometer
  - c. Crushing
2. Distance measuring
  - a. Deformation
  - b. Acoustic spectrometer
3. Multiple measuring (Texture Profile Analysis) e.g., Instron, G. F. Texturometer, Shear Press with recorder, Ottawa Texture Measuring System

From Bourne, M. C., *Hort. Sci.*, 15, 1, 1980. With permission.

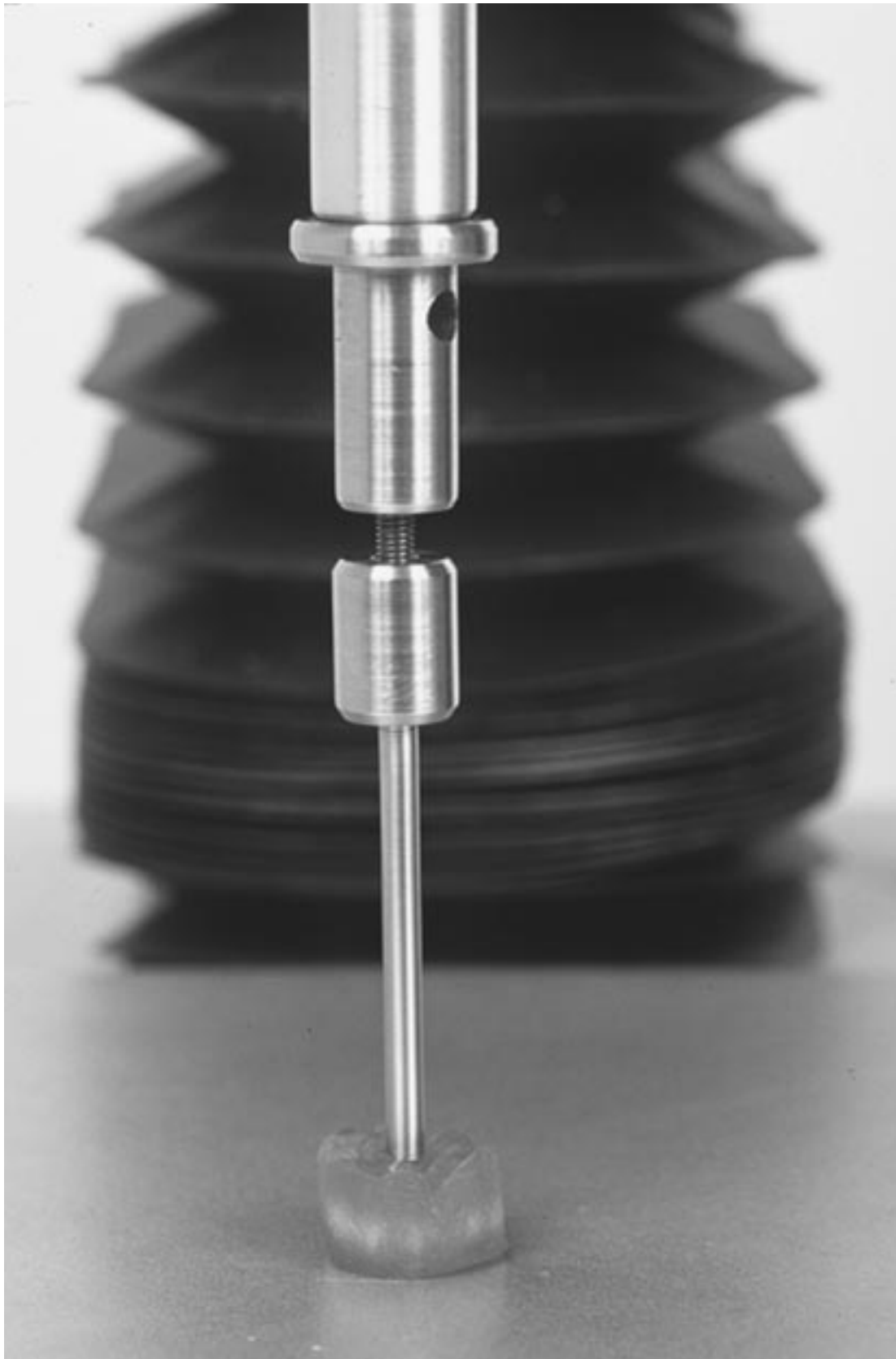

**FIGURE 1.** Puncture testing of a tomato pericarp disk.

Copyright© 1998, CRC Press LLC — Files may be downloaded for personal use only. Reproduction of this material without the consent of the publisher is prohibited.

Maturometer, the Instron, and the Texture Technologies TA-XT2 machine for more controlled measurements; the agreement between hand testers and the Instron, at least, is quite good (Bourne, 1980).

Our laboratory has successfully carried out puncture tests on both tissue disks obtained from the equatorial region of tomato pericarp and single 6.35-mm-thick slices taken from tomato fruit at the equator. Pericarp tissue disks were obtained using a 20-mm cork borer and were evaluated skin side down using a 5-mm probe. For slice evaluation it was necessary to use a 2.5-mm-diameter flat-tipped cylindrical probe and a 500-kg load cell for measurement of outer pericarp, radial arm, and columella tissues.

### *b. Flat Plate Compression*

Flat plate compression is a technique very similar to that of puncture, except that the perimeter effect is eliminated through the use of flat plates of an area exceeding that of the sample. This test may be used in either a destructive or nondestructive manner. Flat plate compression is assumed to be nondestructive when restricted to less than the elastic limit of 3% strain; however, in some cases permanent damage may occur. Similar to the puncture test, this is a force-measuring method with the dimensions mass, length, and time.

In ripening fresh market tomatoes, (Jackman, 1995) found that total area under the curve to failure, maximum force to failure, and initial firmness decreased to a constant and minimum value fairly quickly (e.g., within the first week of ripening to the pink stage). Our laboratory has carried out flat plate compression evaluation of tomato pericarp disks using a flat 7.6-cm-diameter probe. Raw and lightly processed (e.g., steam peeled) tissue displayed a distinct failure peak on a force-deformation curve. However, as tissues softened, this peak disappeared, thus a strict comparison of failure forces was not possible. In this instance, force-deformation curves may be probed for force values at 20% strain, which is well below the failure peak in raw and lightly processed fruit. It should be noted that the flat plate compression

test may not be sensitive enough to determine differences in textural properties of processed tomatoes.

Jackman et al. (Jackman et al., 1990) and Marangoni et al. (Marangoni et al., 1995) also found that small differences in tomato firmness induced by chilling injury were detectable using puncture tests of whole fruit and compression of pericarp disks but were unmeasurable using flat plate compression of whole fruit. The three tests yielded typical force-deformation curves that were particular to each method (Figure 2). Tomatoes evaluated using the flat plate compression method were placed in an axial (vertical) orientation, and the relative firmness or strength of the shoulder area in particular may account for the insensitivity of the method. In these studies, the authors also determined that firmness values (force/length) were more sensitive in detecting treatment differences than peak force values.

### *c. Extrusion*

Extrusion tests are another example of a force-measuring test in which units are expressed as mass, length, and time. A number of different test cells, including the standard shear-compression cell (or Shear Press) and the back extrusion cell, have been designed for the measurement of extrusion behavior (Voisey, 1970). Although use of shear-compression cells involves primarily extrusion, some compression and shear also take place. In this test, a specific weight of sample material is loaded into a test cell that has horizontal slots at the top and bottom. A series of blades passes through the cell, extruding, shearing, and compressing the sample material. Figure 3 illustrates the method for evaluation of a 200-g sample of diced tomatoes using the Shear Press. Voisey (Voisey, 1970) found that both Kramer shear and wire shear extrusion cells were effective tools in force measurements of particulate tomato products. Szczesniak et al. (Szczesniak et al., 1970) found that, depending on the sample, in most foods the ratio of maximum force per gram of sample weight decreased as sample weight increased; therefore, they advised that sample weight be kept constant during extrusion testing.

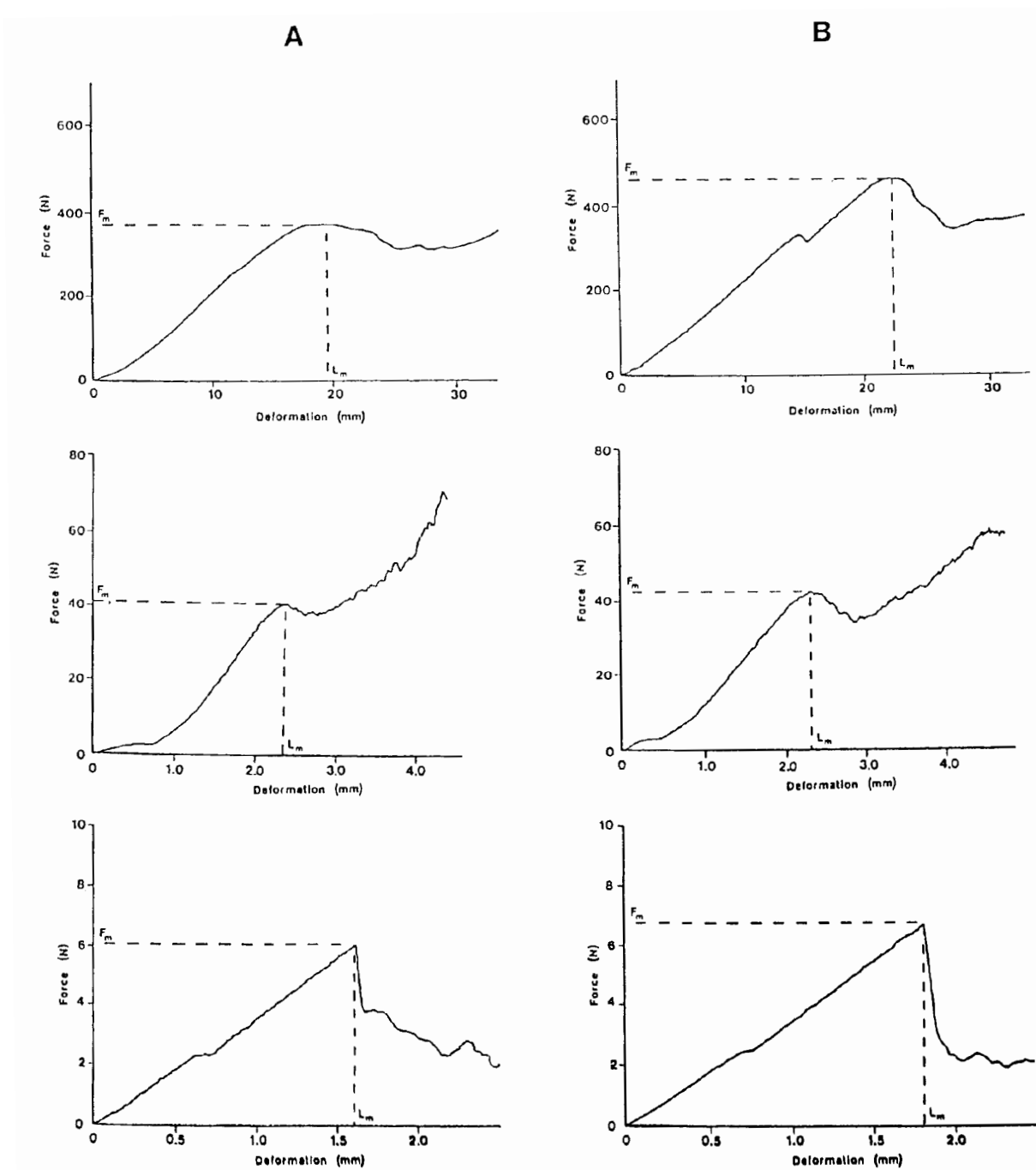

**FIGURE 2.** Typical force-deformation curves for flat-plate compression (top), constant area compression (center) and puncture (bottom) of individual tomatoes. (From Jackman, R. L. and Stanley, D. W., *Hort Science*, 25, July 1990.)

#### d. Multiple Measuring Instruments

Early models of texture evaluation instruments were restricted to “one-point” determinations, but in the 1960s and thereafter several instruments

(e.g., Brabender, Shear Press, General Foods Texturometer, Instron Universal Testing Machine and Ottawa Texture Measuring System) were designed to use a recorder and measure the complete history of a number of force-deformation



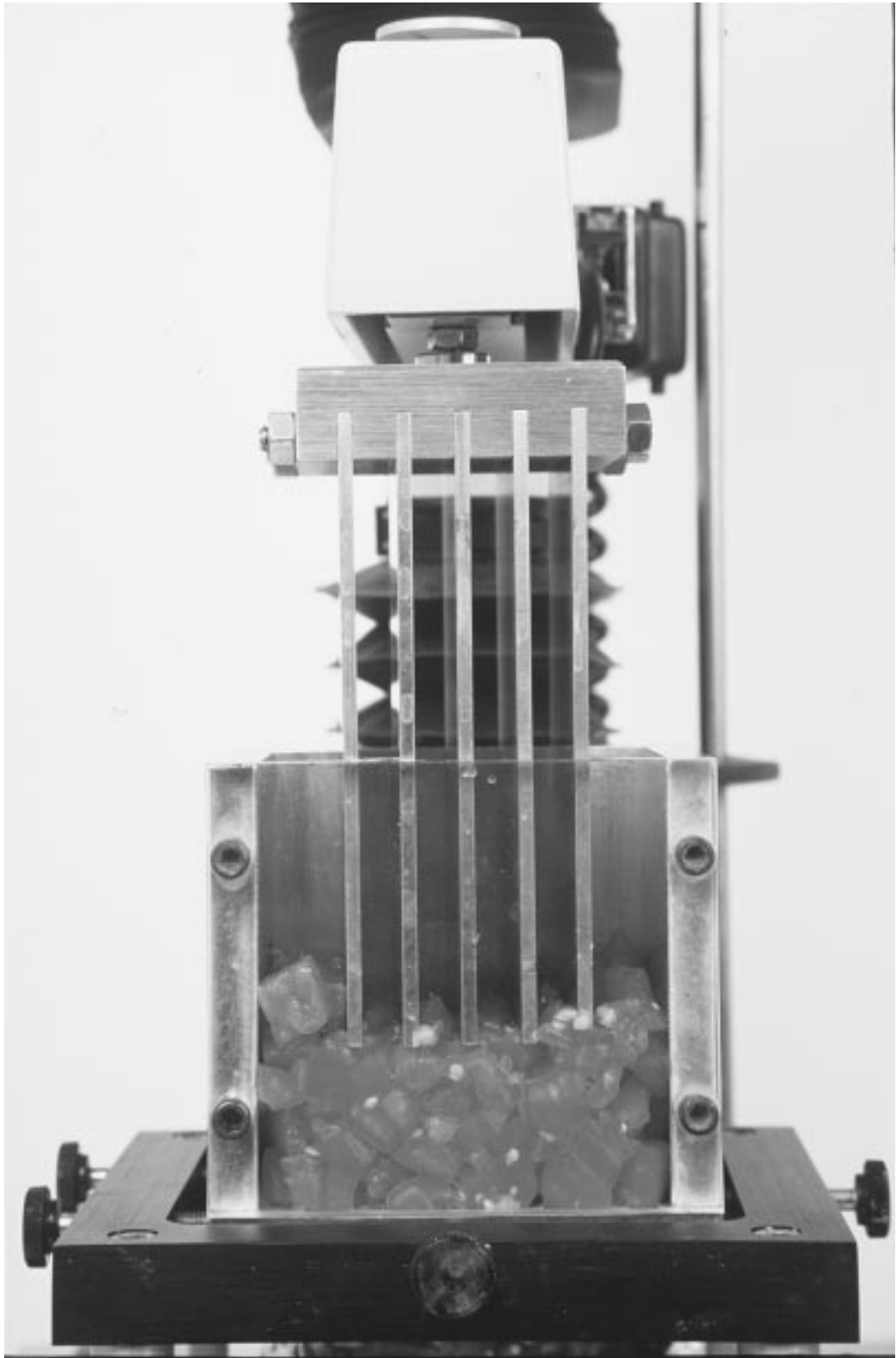

**FIGURE 3.** Shear press evaluation of diced tomatoes.

variables. These instruments are generally very constant and reproducible, capable of being used with relatively high force, and adaptable to several test cells or probes. The only disadvantage to their use is that they are expensive, require some maintenance, and are generally too large to be taken to the field. Texture profile analysis (TPA) is one example of an imitative test that involves double compression of a small cube of food and allows one to obtain the following parameters: fracturability, hardness, cohesiveness (area under compression portion of both curves), adhesiveness, springiness, gumminess (hardness  $\times$  cohesiveness), and chewiness (gumminess  $\times$  springiness).

#### *e. Drained Weight*

Drained weight measurements are relatively gross indicators of the textural properties of whole peeled, diced, chopped, and crushed tomato products. This method does not in fact measure textural properties but a secondary effect, which is weight loss following handling or processing. This method (21 CFR 155.190) consists of opening and pouring an individual can of product over a U.S. Standard Number 2 circular sieve (11.3-mm or 0.446-in opening), waiting for 30 s and then weighing both the filtered liquid volume and the residual solid weight. In the case of sliced and diced tomatoes, a U.S. Standard Number 8 (2.362-mm or 0.093-in opening) circular sieve is used. The Italian Official Methods of Analysis (Foreste, 1989) is quite similar and defines drained weight of canned whole peeled (and also diced) products as the product that remains after 30 s draining on a sieve with holes of 2.8 mm  $\times$  2.8 mm. High drained weight values are desirable and are indicative of tissue moisture retention, juiciness, and relatively greater firmness.

#### *f. Consistency*

The term consistency applies to non-Newtonian fluids with suspended particles and dissolved long chain molecules and is typically measured by the spread or flow of the product.

The insoluble materials present in these products may include intact and broken or crushed cells, cell fragments, and long-chain polymers of lignin, cellulose, hemicellulose, and water-insoluble pectic materials. These suspended particles are highly hydrated and occupy a relatively large volume but contain very little solid material (Kertesz and Loconti, 1944). The consistency of tomato and many other horticultural products is influenced by the presence of both intact cells and cell fragments, the pectic substances on their surfaces, and both soluble pectin and suspended particles in the serum. Investigators at the University of California, Davis (Marsh et al., 1980) found that consistency depended primarily on the ratio of water-insoluble solids to total solids, rather than serum viscosity, but serum viscosity did have an effect on the locus of the tomato paste concentration curve. In many cases, the importance of either consistency or viscosity measurements is dictated by the tomato product being manufactured.

Mohr (Mohr, 1987) compared several objective tomato juice consistency methods for dependability and correlation to sensory ratings by trained judges. These methods included Bostwick consistometer, Brookfield viscometer, Efflux-tube viscometer, Ottawa Texture Measuring System (OTMS), and Cannon-Fenske viscometer. The Bostwick consistometer and OTMS (maximum force value) were found to be the most reliable and correlated well ( $r = -0.91$  and  $0.82$ , respectively) with sensory ratings. Bostwick consistency values for tomato juice also correlated well ( $r = 0.84$ ) with those for concentrated 14% total solids puree. The author recommended that due to its simplicity, versatility, and low cost, Bostwick consistometers be used for routine analyses of tomato products.

#### **i. Bostwick and Adams Consistometers**

The Bostwick consistometer (USDA, 1971) was developed by E. P. Bostwick specifically for the measurement of tomato puree and paste consistency. It is the most frequently used consistency measurement device in the tomato industry today. The Bostwick method involves measurement of the distance a material flows under its

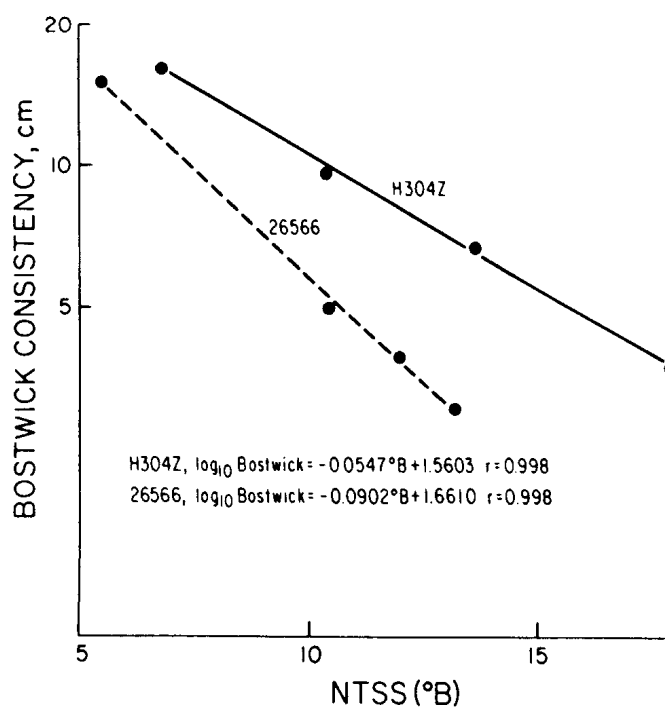

**FIGURE 4.** Concentration of two newly developed tomato cultivars. (From Marsh, G. L. et al., *J. Food Sci.*, 45, 3, 1980.)

own weight along a level surface in a specified amount of time. The consistometer itself is composed of a stainless steel trough with a sample reservoir at one end, which is closed off by a gate that can be opened almost instantaneously.

Marsh (Marsh et al., 1980) found that the rate of change of Bostwick consistency in tomato juice during concentration is a logarithmic function of the change in either total or natural tomato soluble solids (NTSS) content (Figure 4). As concentration of tomato products increases to greater than 15° Brix, use of the Bostwick consistometer is no longer valid because flows are on the order of 1 cm or less. Recently, McCarthy and Seymour (McCarthy and Seymour, 1993; McCarthy and Seymour, 1994) evaluated the effects of the Bostwick width to height ratio on extent of flow and established a relationship between the Bostwick measurement and fluid properties. In all cases, the extent of flow was greater in wider consistometers due to relatively less drag exerted on the fluid by the side walls. Using gravity current analysis, these researchers stated that it may

be possible to predict apparent viscosity for homogenous fluids and fluid suspensions using a single Bostwick measurement.

The Adams consistometer (or Tuc cream corn meter) is similar in principle to the Bostwick, and measurements from each correlate quite well (Gould, 1992). This rapid method measures the distance a semifluid food flows across a plate in a standard time. A clear hard plastic square that is leveled by means of adjustable legs is inscribed on the underside with concentric circles. A cone containing the product is placed in the center of the plate, filled, and gently lifted. The diameter of the product flow is measured along at least two axes at right angles to each other.

## ii. Blotter Test

The Blotter test is a simple, rapid visual measurement that can be easily adapted for quality control purposes. A spoonful of tomato product is dropped onto a blotter (or filter paper) and allowed to stand for a given amount of time, usually

3 min (Gould, 1992). Results can be standardized using products of varying quality and target grades may be established. If the product penetrates the blotter, leaving a wide ring of colorless liquid around the red center, the consistency of the product is determined to be low. If, on the other hand, the tomato product does not readily penetrate the blotter and there is only a narrow ring of colorless liquid, the product is of high consistency.

In 1953, the consistency of tomato puree was evaluated by Davis et al. (Davis et al., 1953) using a variety of methods (i.e., Bostwick consistometer, Adams consistometer, Stormer viscometer, Efflux-tube viscometer, and the Blotter test). The Blotter test was found to correlate fairly well with the Bostwick ( $r = 0.75$ ) and the Adams ( $r = -0.73$ ) but poorly with the other two methods. Correlations between the Bostwick and Adams ( $r = -0.94$ ) consistometers and between the Stormer and Efflux tube viscometers ( $r = 0.91$ ) were likewise very good. Therefore, the authors concluded that the Stormer and Efflux tube viscometers measured different viscous prop-

erties (e.g., liquid rather than suspended solids) of tomato puree than the Bostwick and Adams consistometers and the Blotter test.

### iii. Serum Separation

The serum separation (syneresis) test is another rapid method commonly used for quality control purposes by the tomato processing industry. This test consists of placing a specified amount of tomato product into a filter cone lined with cheesecloth. The fluid from the product is allowed to drain into a graduated cylinder for a certain amount of time, typically 5 min, and the volume is measured. Caradec and Nelson (Caradec and Nelson, 1985) found a strong inverse relationship ( $r = -0.86$ ) between serum separation and precipitate weight ratio (Figure 5), which was determined by calculating the relative weight of the precipitate obtained by centrifuging a weighed sample for 30 min at  $12,800 \times g$  ( $4^\circ\text{C}$ ). Although the serum separation method is fairly widespread in its use, in a comparison of this method with the

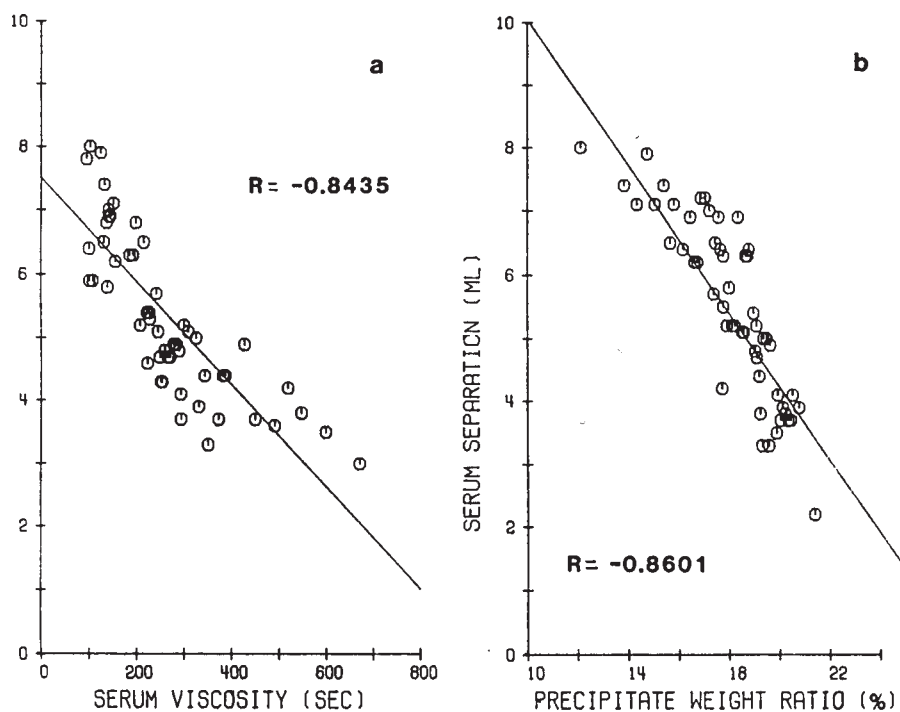

**FIGURE 5.** Correlation of serum separation to serum viscosity and precipitate weight ratio. (From Caradec, P. L. and Nelson, P. E., *J. Food Sci.*, 50, 1985.)

Bostwick carried out in our laboratory, results for the same tomato sauce product were poorly correlated ( $r = 0.42$ ). It may be that the gravitational force exerted during the analysis causes expulsion of serum that would typically remain entrapped within the product matrix. Therefore, use of this method may lead one to conclude that product consistency is poorer than it is actually.

### *g. Viscosity*

Viscosity ( $\pi$ ) has been defined earlier in this section as the internal friction of a fluid or its tendency to resist flow. Tomato products do not generally follow simple Newtonian fluid models in which the relationship between shear stress and shear rate are linear. Rather, tomato products are typically shear-thinning or pseudoplastic fluids in which the apparent viscosity decreases with increasing shear rate. In many instances a measure of tomato serum viscosity is a good index of overall product consistency and provides a measure of the severity of process operations. Analysis of serum viscosity is particularly important in the manufacture of products such as tomato juice and ketchup, where good color and flavor quality are a requirement. Tomato serum contains 4 to 7% dissolved solids, which include primarily sugars, acids, salt, and pectic substances.

For viscosity determination of tomato juice or relatively thin (e.g., low suspended particle concentration) samples, it is common to use glass capillary, tube, concentric cylinder or cone and plate viscometers. The most commonly used instrument for tomato viscosity measurement is the Ostwald glass capillary viscometer. Stormer and Brookfield viscometers have also been used for tomato products, but these instruments are typically expensive and require additional expertise to operate, thus prohibiting their use for routine quality analysis.

The serum viscosity measurement involves separation of serum from paste by either filtration or centrifugation, then a standard volume is pipetted into a wide-bore arm of the viscometer that is held in a vertical plane in a constant temperature (typically 25 to 30°C) bath. After temperature equilibration is achieved, suction is ap-

plied to pull the sample through the capillary arm, and flow time through a specific length of the narrow-bore glass is measured. This type of instrument is relatively inexpensive, fairly precise and easy to operate and is suitable as a quality control instrument. Marsh et al. (Marsh et al., 1980) found that serum viscosity was a major factor in determining the locus of the tomato paste concentration curve.

The behavior of fluids has been characterized using nuclear magnetic resonance (NMR) velocity spectrum measurements (Seymour et al., 1995). The velocity probability distribution function is measured with a velocity phase encoding NMR technique, and it is possible to distinguish between materials exhibiting Newtonian, shear-thinning, and yield stress (Bingham) flow behavior. A 6.2% (wt.) solids tomato juice product was characterized by these authors as having shear-thinning behavior and, in the model system used, it was possible to monitor juice viscosity on-line.

## **2. Nondestructive Tests**

Tests that apply a small amount of deformation or force traditionally have been termed “non-destructive,” although Jackman and Stanley (Jackman and Stanley, 1995) hold that this classification may be misleading. Plant tissues, including tomatoes, possess both elastic (time-independent) and viscous (time-dependent) characteristics, and it may be argued that no application of deformation or force over a measurable period of time is truly nondestructive. Indeed, following compression a portion of the energy invested is irrecoverable due to internal friction and irreversible structural modifications (Peleg, 1980). Nonetheless, a number of instrumental procedures for evaluation of the textural properties of tomatoes are commonly considered nondestructive, and these are described briefly in the following section. While nondestructive techniques may not necessarily correlate well with sensory evaluations, because the deforming force is generally less than 3% strain and therefore does not induce tissue failure, they provide essential information regarding tomato tissue structure and composition and allow for a better understanding

of the mechanism(s) responsible for tissue failure. Nondestructive tests have been used for repeated measures on the same unit, theoretically without a change in the character of the tissue.

### 1. Flat Plate Compression

Bourne utilized small-magnitude deformation or strain tests in order to repeatedly evaluate the deformability of two varieties of fresh market tomatoes as they ripened (Bourne, 1973). Small strain was defined either as less than 25% absolute compression or less than 50% of the rupture (Bourne, 1979). A low-cost penetrometer was fitted with a flat plastic disc that was allowed to fall freely for a set time, after which the distance fallen was measured. The use of this small-magnitude deformation method (commonly termed flat plate compression) was effective in discriminating between the two varieties in terms of initial softness and storage stability as determined by change in deformation (Figure 18). In this example it was desirable to resolve two samples of similar deformability, and the use of small deforming forces was more sensitive than the use of large strains.

Jackman (Jackman, 1995) has noted that flat plate compression measurements of whole tomato fruit may reflect a combination of compression, shearing, and tension and may not be very sensitive to tissue properties per se. In such a test, factors such as fruit size, shape and turgor, viscosity and content of locular fluid, number of ribs, and total amount and structural integrity of columellar tissue, pericarp thickness, and skin integrity all influence the measured value. Indeed, if successive compressions are carried out, the stress-strain relationship indicates that an increased force is required to reach the same strain level until the internal tissue structure reaches a steady-state condition. Although this method does appear to result in irrecoverable changes in a situation where a nondestructive test and/or repeated measures are required, flat plate compression of whole tomatoes may impart useful information if used with caution.

Recently, our laboratory was asked to carry out a validation study to compare potential meth-

ods for quantifying the human “finger feel”, or gentle squeeze applied by consumers to whole fresh market tomatoes. A method similar to that developed by Bourne (above) was compared with a new method using the Instron Universal Testing Machine, and sensory rankings of a controlled population were used as a reference standard. Ripe, undamaged fruit were grouped by sensory analysis into five firmness categories (Hard, Very Firm, Firm, Firm with Give, and Soft), and further ranked within each category from most to least firm. The quantitative methods were as follows:

1. Modified penetrometer deformation. A 500-g weight was applied (radially) for a constant time period and deformation was measured (mm) for a single point.
2. Instron axial (vertical) deformation. Fruits were subjected to axial compression of an initial pre-load of 0.1 kg and subsequently to a total load of 1.0 kg. Resultant delta deformation was measured in millimeters. One data point per fruit was taken. (This variation was included because historically most whole fruit firmness studies have been in axial mode.)
3. Instron radial (horizontal) deformation ( $n = 4$ ). Same procedure as 2, except four data points per fruit were taken at  $45^\circ$  rotations along the equator.
4. Instron radial deformation ( $n = 1$ ). This is a subset of procedure 3, where the first data point (from original  $n = 4$  data set) for each fruit is case 1, and the second data point per fruit is case 2.

A custom brace to gently hold tomatoes in a radial position was designed and the Instron method employed a flat disk probe, 3 in. in diameter, and a 2 kg load cell. The diameter at each position was measured and recorded prior to compression. The crosshead moved at a constant speed of 20 mm/min. Spearman's Rho, which is a measure of linear association between ranks of variables, similar to the linear regression for parametric statistics, was utilized for analysis of the data. The five variations of the small magnitude deformation test under investigation were compared in

terms of total range in deformation values, and range for each sensory category, category average, and Spearman's Rho value vs. sensory average. Results are shown in Table 3 and are summarized as follows:

- **Total Range (mm):** A wide range is most desirable, suggesting the method can clearly differentiate between hard and soft fruit. The Instron radial ( $n = 4$ ) method had the greatest total range (5.143 mm). The modified penetrometer deformation method had the least range (1.85 mm).
- **Category Range (mm):** This comparison revealed that the modified penetrometer method could not distinguish between the first two firmness categories. Category ranges were the widest for Instron radial,  $n = 4$ , and least wide for the modified penetrometer deformation method and the Instron axial method.
- **Category Averages and Standard Deviations (mm):** These data were evaluated along with the scatter plots of all the data for each method. Despite significant overlap between categories for all methods, the same fruit were more clearly

differentiated with the Instron radial,  $n = 4$  data. Additionally, the standard deviations for the modified penetrometer method were quite large, especially when compared with the Instron data.

- **Spearman's Rho:** Statistical tables show that rho is significant at the 90% level if equal to 0.175, and significant at the 95% level if equal to 0.786. Virtually all categories were significant at 95% for Instron radial,  $n = 4$ . Only one category was significant (at 90%) for the modified penetrometer method.

The new Instron method of radial deformation,  $n = 4$ , was clearly able to distinguish between tomato fruit firmness in these categories. The new method was superior to the modified penetrometer deformation test in every comparison made (total ranges, standard deviations, Spearman's Rho, etc.). The axial data were somewhat better than the modified penetrometer deformation data, but still had a narrow total range and overall poor correlations with Spearman's Rho test. This mode of deformation does not correlate to "finger feel" as well as the radial mode does, as

**TABLE 3**  
**Deformation Values Obtained Using Five Different Flat Plate Compression Tests**

	Modified penetrometer deformation	Instron axial	n = 4 Instron radial	n = 1 case 1 Instron radial	n = 1 case 2 Instron radial
Total range (mm)	1.85	2.700	5.143	4.902	4.691
Category ranges (mm)					
Hard	0.09	0.210	0.752	0.511	0.421
Very firm	0.00	0.900	1.594	1.173	0.717
Firm	0.70	1.350	3.098	2.466	2.887
Firm w/ give	1.82	1.950	3.008	2.737	2.526
Soft	1.60	1.020	2.067	1.534	1.383
Category average (Std dev)					
Hard	0.01 (0.03)	0.477 (0.088)	0.859 (0.164)	0.926 (0.149)	0.932 (0.149)
Very firm	0.00 (0.00)	0.782 (0.303)	1.540 (0.385)	1.757 (0.421)	1.569 (0.240)
Firm	0.16 (0.25)	1.293 (0.597)	2.361 (0.748)	2.513 (0.874)	2.552 (1.073)
Firm w/ give	0.84 (0.54)	1.662 (0.616)	3.556 (0.762)	3.951 (0.953)	3.752 (0.979)
Soft	0.79 (0.47)	2.128 (0.335)	3.756 (0.512)	4.015 (0.481)	3.835 (0.395)
Spearman's Rho vs. sensory average					
Hard	0.286	-0.223	0.714	0.098	0.295
Very firm	0.509	0.393	0.991	0.554	0.938
Firm	0.616	0.786	0.848	0.723	0.598
Firm w/ give	0.762	0.762	0.929	0.762	0.952
Soft	0.220	0.268	0.792	0.839	0.613

was expected. Practically, evaluating four data points per fruit was time consuming and could be expensive if it were to be used as a quality control measure. Reducing the sampling base was not without some cost, but the single point data extracted from the  $n = 4$  data set was still superior to both the modified penetrometer deformation method and the Instron axial method.

## **2. Resonance (Dynamic Oscillation, Vibration, or Sonic Transmission)**

Resonance theory has its basis in dynamics and is founded on the fact that any body that possesses both mass and elasticity is capable of vibrating. Free vibration may be exhibited at one or more frequencies and is dependent on the specific physicochemical properties of the food itself. On the other hand, forced vibration over a range of frequencies results when an external force is applied periodically (Jackman et al., in press) and a series of resonance peaks may be observed. The two lowest frequencies correlate with fruit firmness and overall elastic behavior, and stiffness factors are commonly used as indices of textural quality (Jackman and Stanley, 1995; Peleg et al., 1990).

For an elastic solid, shear stress is in phase with strain, but for a Newtonian fluid the shear stress is  $90^\circ$  out of phase with the strain. In viscoelastic fluids or foods, the shear stress lags behind the strain by an angle of difference ( $\phi$ ), or raw phase angle, that lies between  $0^\circ$  and  $90^\circ$ . Resonance tests may be used to measure solid samples of known dimensions or liquid samples placed in a container with standard dimensions. The sample is subjected to repeated small sinusoidal deformations that are nondestructive and do not cause fracture (Bourne, 1993).

Pioneering efforts in the development of vibration techniques for evaluation of fruit and vegetable texture were made by Abbott et al. (Abbott et al., 1968) and Finney and Norris (Finney and Norris, 1968; Finney, 1972) in the late 1960s. Using vibrational responses in the frequency range from 20 to 10,000 Hz it was deemed possible to separate fruit by maturity and textural properties. In studies carried out primarily on apples, numerous investigators have since found good correlation between resonance (also termed dynamic

oscillation, acoustic, or sonic) methods and both sensory and destructive compression and puncture tests (Abbott et al., 1995; Abbott et al., 1992).

Stephenson et al. (Stephenson et al., 1973) utilized a tuned vibrator to excite three varieties of tomatoes to determine whether distinctly different resonant bandwidths existed for red ripe and green tomatoes. All three varieties of ripe fruit exhibited sharp resonant peaks between 200 and 400 Hz, and one quite firm variety (Red Rock) had a second peak at 1050 Hz. No significant peaks were exhibited by any ripe variety at frequencies greater than 1300 Hz. Green fruit of all varieties had resonant peaks between 300 and 960 Hz and large amplitude peaks at higher frequencies from 1340 to 2100 Hz. Therefore, the authors concluded that vibrational response in the bandwidth of 1400 to 2000 Hz could be applied to detect and sort green fruit. Saltveit (Saltveit et al., 1985) found that the frequency and amplitude of sounds produced by struck green tomato fruit correlated with days to reach the breaker maturity stage.

Jackman has utilized dynamic oscillation techniques to evaluate the oscillatory strain and viscoelastic parameters of excised tomato discs in order to determine the effects of turgor pressure and chilling on structure and failure mechanisms (Jackman et al., 1992; Jackman and Stanley, 1992; Jackman et al., in press). Tomato tissue resonance behavior has been compared to more traditional large deformation (e.g., destructive) measurements, such as puncture and flat plate compression (Jackman and Stanley, 1992; Jackman et al., in press). Significant correlations were observed between resonance frequency and the logarithm of compression parameters, especially the parameters associated with tissue failure (Table 4). Therefore, Jackman et al. (Jackman et al., in press) suggest that it might be possible to use one instrument over a range of frequencies to predict tissue compression behavior merely by measuring resonance frequency ( $f_r$ ).

## **3. Creep Compliance**

Recently, Jackman and Stanley (Jackman and Stanley, 1995) utilized creep tests to estimate separate elastic, viscoelastic, and viscous flow



**TABLE 4**  
**Semilog Relationship between Tomato Pericarp**  
**Frequency and Compression Tests**

Regression equation	Regression coefficient <sup>a</sup> (r <sup>2</sup> )
$f_r = -3.387 + 17.042 (\log \sigma_y)$	0.572*
$f_r = -21.701 + 18.836 (\log E_{app})$	0.649*
$f_r = -35.671 + 20.956 (\log D_f)$	0.767**
$f_r = -6.870 + 12.546 (\log \sigma_{max})$	0.832**
$f_r = 1.874 + 10.095 (\log E)$	0.838**

Note: Abbreviations:  $f_r$ , frequency;  $\sigma_y$ , bioyield strength;  $E_{app}$ , apparent elastic modulus;  $D_f$ , failure deformability modulus;  $\sigma_{max}$ , failure strength; E, toughness.

<sup>a</sup> Significance levels: \* =  $P < 0.05$ ; \*\* =  $P < 0.01$ .

From Jackman, R. L. et al., *J. Texture Studies*, in press.

characteristics in excised pericarp disks from fresh market tomatoes. This method of evaluation is similar to that previously used in dynamic oscillation studies, in which a controlled stress rheometer with parallel plate geometry was the test instrument. A constant torsional stress of 150 Pa was applied to the tissue disc, and its strain response was monitored over time. On the basis of creep tests, the physico-mechanical behavior of tomato pericarp tissue was shown to fit a 6-element Burgers model (Jackman and Stanley, 1995) and was defined in terms of four separate compliances (strain/stress). These compliances and their contributions to overall compliance of fresh market tomato tissues during ripening and storage were stated to be as follows: an instantaneous elastic compliance; a slow-rate viscoelastic compliance; a fast-rate viscoelastic compliance and a steady-state viscous flow compliance. The authors went on to attribute elements of this model to general plant cell wall structures given the biochemical changes that they are known to incur during tomato fruit ripening.

Sakurai and Nevins (Sakurai and Nevins, 1993) utilized a novel method of applying stress to tomato pericarp disks via a conical probe to a depth of 0.6 mm, then employed a strain gauge to measure deflection of an arm calibrated according to the load. Mature red tissues were compared with green, and it was determined that significant

decreases in initial stress, minimum and maximum stress-relaxation times could be used to predict losses of both tissue viscosity and elasticity. These authors found that pectin solubilization, depolymerization of xyloglucans, and changes in cell wall polysaccharide fractions were all contributors to alterations in the physical properties measured using techniques based on stress-relaxation.

### C. Microstructural Evaluation

The textural properties of food products are dictated to a large degree by the structural organization of component anatomical parts. We have seen in tomatoes, for example, that there is a wide diversity in tissue types, including skin, pericarp, locules, columella, and radial arms. The use of microscopic and other techniques to study food structure and the way in which this arrangement of tissue types relates to both sensory and instrumental measurements of texture has increased dramatically in the last 2 decades.

Very little work was published on the correlation between fruit and vegetable structure and texture prior to 1940, and even those studies concentrated primarily on comparative morphology. Reeve (Reeve, 1970) was one of the first to point out that interrelationships between tissue struc-

ture and composition contribute to a large range of textural qualities in fresh and processed fruits and vegetables. He noted that the size and shape of cells, cellular outgrowths, and the natural deposition of materials on the external surfaces of cells influenced textural appearance. Reeve found that small cells with few or tiny intercellular spaces formed a compact texture, while large cells that often had large intercellular spaces formed a coarse or spongy texture. He postulated that differences in pectic constituents as well as differences in the total amount of cell wall materials per unit tissue volume should correlate with differences in softness and overall textural appearance.

More recently, Stanley has been one of the key players in evaluation of microstructural elements of food products and their relation to textural properties, and he has categorized various techniques used in this field (Table 5) (Stanley, 1987). Low power examination is the best for discerning interacting elements, but often more than one technique is required for a complete picture of microstructural organization.

## D. Chemical Methods

The textural properties of tomatoes may also be evaluated in terms of their component parts, the most important of which include total and insoluble solids, soluble pectins, size of insoluble polymers, and both degree of polymerization and degree of esterification of insoluble polymers. In addition, the activity of texture-affecting enzymes such as pectin methylesterase, polygalacturonase, and cellulases may be measured. These methods are described briefly.

### 1. Total, Water-Soluble, and Water-Insoluble Solids

When speaking of tomato products, it is important to distinguish between total solids, water-soluble (or just “soluble”) solids, and water-insoluble solids. The tomato processing industry has a tendency to refer merely to “solids”, and in most cases soluble solids are implied; however, the terminology can be confusing to the unenlightened.

Total solids (TS) represent all the solid components of the tomato (approx. 5 to 7% by weight), excluding the seeds and skin. Total solids are measured by calculating the ratio of tomato product weight to its weight after removing the water by drying in a vacuum oven (Lamb, 1977). Conversely, one may derive moisture content (excluding seeds and skin) as the percentage weight removed by drying. Water-soluble solids (e.g., low MW compounds) present in tomatoes comprise 80 to 90% of the total solids content and include sugars, organic acids, amino acids, soluble pectins, and mineral salts. Soluble solids (SS) is determined in the same way by vacuum drying serum separated by centrifuging and filtering out the insoluble material.

For quality control purposes, it is easier and faster to determine natural tomato soluble solids (NTSS) or °Brix in tomato serum by refractometer. “Natural” implies the tomato soluble solids without added salt and the NTSS or °Brix value is a useful index of concentration and an indication of consistency. Although NTSS values closely approximate the water-soluble solid content obtained by drying, they are not a measure of the actual sugar content and are not related in a constant manner to total solids across varieties. NTSS or °Brix values are typically 0.2 to 0.4 units higher than SS values obtained by drying for juice samples, and are even more skewed for higher solids samples (Wolcott, 1982).

Water-insoluble solids (WIS) content represents the higher MW cell wall and middle lamella components that are important determinates of consistency. WIS are determined by difference, which is by subtracting the percent water-soluble solids from the percent total solids. The procedure used by Lamb (Lamb, 1977) is typically utilized:

$$\text{WIS} = 100 (\text{Total Solids} - \text{Soluble Solids}) / 100 - \text{Soluble Solids}$$

WIS may also be determined by filtering the product, washing to remove water-soluble compounds, drying and weighing the insoluble residue. Good agreement has been found by UCD researchers between the two methods, but the difference method is much faster and easier.

**TABLE 5**  
**Microscopic Techniques Used for Evaluation of Food**

	Magnification range	Information provided
Magnifying devices		
Transmission light microscope (TLM)	10 to 1,000 ×	Images of surfaces and sections; poor depth of field
Scanning electron microscope (SEM)	20 to 100,000 ×	Electronic image of surfaces and sections; good depth of field and magnification range
Transmission electron microscope (TEM)	200 to 3,000,000 ×	Electronic image of thin sections; difficult sample preparation
Scanning transmission electron microscope (STEM)	Same as TEM	Combines characteristics of SEM and TEM
Non-magnifying devices		
X-ray microanalysis		Used in combination with electron optics; provides quantitative spectra of elements (>A.N. = 11)
Differential scanning calorimeter (DSC)		Quantitation (T transition, ΔH) of thermal events

From Stanley, D.W. In: *Food texture: instrumental and sensory measurement*, 1st ed., Moskowitz, H. R., Ed., Marcel Dekker, 1987. With permission.

To compensate for variations in total solids between varieties, WIS values are most appropriately expressed as a ratio or percentage (e.g., WIS/TS). When multiplied by 100, this ratio expresses the percentage of water-soluble solids in the total solids fraction of the sample. UCD studies carried out from 1974 to 1980, the period in which breeders were selecting firmer varieties of tomatoes, showed that varietal changes resulted in a WIS/TS increase from 9 to 19% (Wolcott, 1982). WIS content markedly affects consistency and the rate of change of Bostwick consistency with a change of soluble solids during concentration. Marsh et al. (Marsh et al., 1980) illustrated (Figure 6) the importance of the WIS/TS ratio by plotting 4 years of results for WIS/TS against the slope (b) of the Bostwick vs. NTSS concentration curve (see Figure 4). These authors found that the higher the WIS/TS ratio for a tomato product, the greater the Bostwick consistency at any given level of TS or NTSS.

## 2. Total Pectin

Total pectin content may be evaluated in both tomato pulp and tomato serum. Pulp analysis may

be carried out using the versene-pectinase carbazole method developed in 1952 by McCready and McComb (McCready and McComb, 1952). This method involves extraction of all pectic substances in fruit tissue at pH 7 and below with mild heating, followed by determination and characterization of total pectic substances such as anhydrouronic acid. Fresh tissue is blender with 95% ethyl alcohol, filtered, and the ethyl alcohol containing the sugars is discarded. Then the pulp is washed twice with 75% ethyl alcohol, and the cations and sequestered and the pectin deesterified by adding 0.5% versene solution (ethylenediamine-tetraacetic acid tetrasodium salt) at pH 11.5 and holding at 25°C for 30 min. The solution is acidified to pH 5 to 5.5 with acetic acid, pectinase is added and the solution stirred for 1 h, diluted and filtered. Deesterified galacturonide or polymer are added to the solution, and aliquots are measured colorimetrically with carbazole reagent.

Total pectin in tomato serum may be determined by taking serum obtained from serum viscosity measurements (e.g., centrifuged at  $600 \times g$  for 30 min and filtered through Whatman No. 90 paper), pipetting this into a centrifuge tube and then adding 30 ml of 95% ethanol and eight drops 0.5 N HCl. The solution is mixed and centrifuged

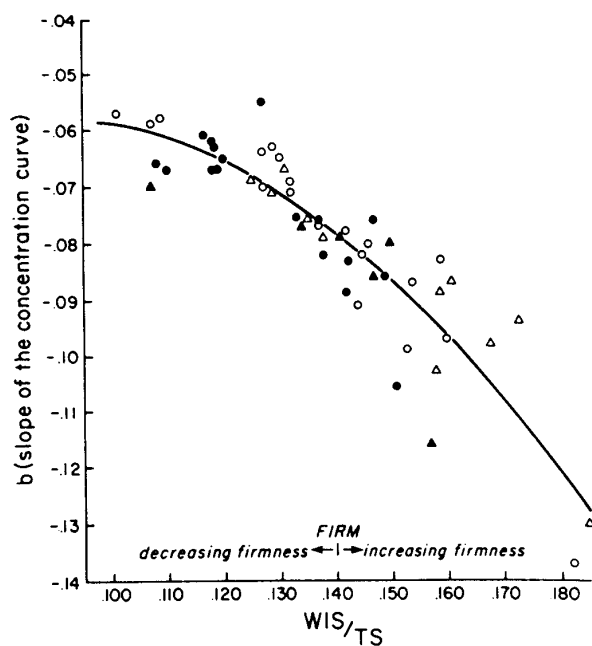

**FIGURE 6.** Relationship between slope of concentration curve and WIS/TS ration. (From Marsh, G. L. et al., *J. Food Sci.*, 45, 3, 1980.)

for 20 min at 10,000 rpm ( $12,100 \times g$ ) at 34°F according to the method of Luh and Daoud (Luh and Daoud, 1971). The supernatant is decanted, and the residue washed once with 30 ml 95% ethanol and twice with 30 ml of 70% ethanol. Twenty-five ml of 0.05 N NaOH are added to residue, and it is allowed to stand 1 h. Then the mixture is diluted with distilled water to 500 ml, and 2 ml of the resulting solution is used for analysis by the H<sub>2</sub>SO<sub>4</sub>-carbazole method (McCready and McComb, 1952).

### **3. Cell Wall and Middle Lamella Polymers**

Tomato polymers may be further evaluated by extracting cell wall material, chromatographing isolated pectins and determining the degree of polymerization (DP) and degree of esterification (DE) of component polymers. Cell wall material (CWM) may be prepared by heat inactivation in 50% ethanol, which serves to inactivate constitutive enzymes and protect pectins from  $\beta$ -elimination reactions (Koch and Nevins, 1989). The evaluation of DE may be carried out after dehydrating the CWM with acetone, followed by vacuum drying. Identification of galacturonic acid is performed after reduction of carboxyl groups, and the conversion of galacturonic acid to galactose is verified by gas-liquid chromatography of alditol acetates.

In order to calculate DP, which reflects average polymer size, it is necessary to analyze the sample for pectin content and galacturonic acid reducing groups. DP is equal to the moles of galacturonic acid residues divided by the moles of uronic reducing groups. Pectin concentration may be determined using the meta-hydroxydiphenyl assay (Blumenkrantz and Asboe-Hansen, 1973), and the quantification of galacturonic acid reducing endgroups can be carried out according to Sajjaanantakul et al. (Sajjaanantakul et al., 1989).

Isolated polyuronides may be chromatographed using gel filtration on a Sephacryl S-400 column (Seymour and Harding, 1987), and more complete fractionation may be achieved through the procedure of Fishman et al. (Fishman

et al., 1991). The isolated pectins are fractionated by passing them through a series of three columns: a Waters  $\mu$ Bondagel E-high, Waters E-100, and a Synchronapak GPC-100. Column effluent detection is performed using a refractive index detector. Molecular weight determination of the pectic fractions eluted is carried out using a technique of low-speed sedimentation-equilibrium (Seymour and Harding, 1987).

### **4. Enzymes**

Polygalacturonase (PG) is assayed by incubation of enzyme extracts with a solution of polygalacturonic acid at the optimum pH and temperature for enzyme action. Blanks are prepared by previous boiling of the reaction mixtures before addition of substrate (Pressey, 1986). After appropriate incubation periods, aliquots are taken for analysis of reducing groups using disodium 2,2' bicinchoninate (McFeeters, 1980).

Pectin esterase (PE) measurement focuses on the principle that ester bonds of the substrate polygalacturonic acid methyl ester are hydrolyzed, and acid groups are released, causing a lowering of pH. This assay is based on the color change of the pH indicator, bromothymol blue, during the reaction catalyzed by PE. As the pH is lowered, bromothymol blue changes color, which can be monitored spectrophotometrically (Hagerman and Austin, 1986).

### **5. Alcohol-Insoluble Solids**

Determination of alcohol-insoluble solids (AIS) is a good indication of maturity and texture in some horticultural products. In tomatoes, alcohol-insoluble solids include: protein (8%), pectic substances (7%), hemicellulose (4%), and cellulose (6%) dry matter (Davies and Hobson, 1981). The method (Association of Official Analytical Chemists Method 32.006) for evaluation of AIS involves blending tomatoes in 80% alcohol, filtering on a vacuum filter, washing with additional 80% alcohol, drying and weighing the residue.

Janoria and Rhodes (1974) found that AIS content of fresh market tomato fruit was highly

correlated with viscosity, as measured by a Brookfield viscometer on microwaved samples. Correlation coefficient values, based on 12 cultivars, were  $r = 0.94$  for whole fruit extracted with 75% ethanol. Investigators separated fruit into three anatomical tissues, outer and inner pericarp, and locular contents and found the correlation of AIS with viscosity was high for outer pericarp,  $r = 0.93$ , and inner pericarp,  $r = 0.78$ , but low for locular contents,  $r = 0.18$ . A principal component analysis indicated that fruit size, shape and firmness, total solids, proportion of outer and inner pericarp, and locular contents were not highly associated with either AIS or viscosity.

It was noted that AIS is a small fraction of the total solid content of tomato juice, yet it accounts for a significant variation in juice viscosity. For example, the range of AIS in the 12 varieties studied in this trial was 2.9 to 7.4% of total solid content, but its coefficient of determination ( $r^2$ ) with viscosity was estimated to be 0.88 (Janoria and Rhodes, 1974). In terms of breeding potential, an increase in the weight proportion of outer pericarp may not result in an increase in the AIS (outer) or AIS (whole) content because the percentage outer pericarp was found to vary independently of AIS (outer and whole).

### **E. Correlation of Sensory Methods with Objective, Microstructural and Chemical Methods, and Criteria for Method Selection**

Although sensory methods are preferred because of their strong correlation with consumer judgments, objective instrumental or chemical methods are often faster and less expensive. For this reason, many scientists use objective methods to evaluate textural properties. In the final analysis, however, objective methods of textural property evaluation must correlate well with sensory judgments. Szczesniak (1987) cites the following as reasons researchers seek correlations: (1) need for quality control instruments; (2) desire to predict consumer response; (3) desire to understand what is being perceived by sensory test; and (4) need to develop improved instrumental test methods that will ultimately duplicate sensory evaluation.

One difficulty frequently encountered in correlating instrumental and sensory results is poor definition of the textural property being measured. In addition, when correlating instrumental and sensory results, one must consider differences in sample variability or reproducibility (greater with instrumental than sensory analysis) and the sensitivity of both instrumental and human sensors. The sensitivity of a sensory panel is usually better, but if there is great scatter (low reproducibility) in sensory ratings, differences may not be significant (Kapsalis and Moskowitz, 1977). It is important to realize the limits of correlation of each approach. Szczesniak (1979) found that, with different foods, optimum agreement between sensory and objective evaluation occurs at different force/percent compression values, illustrating the importance of initial testing to set test parameters.

The literature contains relatively few well-conducted studies of textural properties that correlate sensory analysis results with those of objective methods. There are even fewer examples relating sensory evaluation to microstructural or chemical analyses. In most cases, methods are compared by statistical analysis of the results and simple calculation of correlation coefficients. Kader et al. (Kader et al., 1978) evaluated two objective methods (one destructive, one nondestructive) and a sensory judgment of fresh market tomato firmness. The UC fruit firmness tester was utilized for the destructive puncture-type test and a nondestructive compression method based on pressing two steel balls against the sides of the tomato and measuring deformation was also used. These methods were compared with the sensory method of feeling fruit with the fingers along the equatorial diameter of the fruit with specific attention to measurements being made over the locules rather than the radial walls. Sensory scores were highly correlated with both nondestructive deformation measurements ( $r = -0.81$ ) and destructive pressure test values ( $r = 0.79$ ). In addition, the two objective tests correlated fairly well ( $r = -0.75$ ) with each other. Table 6 illustrates the agreement obtained between the three methods.

Gormley and Keppel (Gormley and Keppel, 1976) measured whole fresh market tomato fruit firmness with a modified shear press by compressing (radially) individual fruit by 5 mm between two flat surfaces. This deformation resulted

**TABLE 6**  
**Relationship between Subjective and Objective Firmness**  
**Measurements for Whole Tomato Fruit Firmness**

Subjective firmness score and class	Deformation (mm) at 1 s using a 2.2 N compressive force	UC fruit firmness tester reading (kg) with a 7.9 mm plunger
6 = Very firm	0.8 ± 0.4	2.18 ± 0.48
5 = Firm	1.3 ± 0.5	1.81 ± 0.39
4 = Fairly firm	1.6 ± 0.6	1.27 ± 0.27
3 = Soft	2.3 ± 0.6	1.00 ± 0.20
2 = Very soft	2.7 ± 0.3	0.73 ± 0.25

From Kader, A. A., *J. Amer. Soc. Hort. Sci.*, 103, 1, 1978.

in firmness readings of 1700 to 550 g, depending on the age of the fruit. A 12-member sensory panel of individuals experienced in tomato production and marketing was asked to rank fruit in order (1 to 10) from firmest to softest on the basis of finger feel. The rank correlation coefficient between tomato firmness as measured by finger feel and shear press was 0.988. The break point in fruit firmness between suitability and unsuitability for sale at the retail level was taken at 680 g, while that for tomatoes usable in the home, that is, capable of being sliced easily, was 540 g.

The relationship between sensory attributes and objective measurements of fresh market tomato quality was also investigated by Resurreccion and Shewfelt (Resurreccion and Shewfelt, 1985). Nineteen different sensory and objective variables were evaluated and Table 7 illustrates how the data were first simplified by clustering groups of variables into nonoverlapping clusters. Analysis of individual factors found that sensory tomato color measurements were highly correlated with objective color measurements L and  $\tan^{-1} b/a$  ( $r = -0.66$ ,  $P < 0.0001$ ) and whole fruit firmness as measured by a penetrometer ( $r = -0.61$ ,  $P < 0.0001$ ). It is interesting to note that the only objective measures that correlated with sensory analysis were firmness and color.

Table 8 summarizes the methods described above which may be applied to characterization of the textural properties of tomatoes. Faced with what may seem to be an overwhelming number of choices, it is useful to review the following criteria, which have been adapted from

Bourne (Bourne, 1993) as a guide to method selection:

1. Purpose: routine quality assurance or a research tool?
2. Nature of product: liquid, solid, viscoelastic, homogeneous, or heterogeneous?
3. Cost: capital equipment cost, including operation and maintenance; cost of training, and maintaining a sensory texture panel?
4. Time: results needed immediately for decision making (e.g., quality assurance) or more long-term evaluation?
5. Location: used in field, processing plant, or on the laboratory bench?
6. Nature of sensory evaluation method used by people: is the product typically squeezed, cut by incisors, crushed between molars, rolled with tongue, etc.?

After reviewing all of the above criteria, one will hopefully be left with two or three potential test principles, which should be tested over the full range of textures normally encountered in the food and correlated with sensory evaluation (Bourne, 1993). Using statistical analysis to evaluate the results should identify which principle and instrument are the best for a certain product. Finally, test conditions must be established and standardized such that they give the strongest distinction between different samples.

In terms of the evaluation of textural properties of processing tomatoes, liquid and semi-solid tomato products such as juice, sauce, and paste

**TABLE 7**  
**Cluster Structure and Factor Pattern of Sensory and**  
**Objective Measures of Postharvest Quality**

Variable	Type of measurement <sup>a</sup>	Cluster	(R <sup>2</sup> )	Factor <sup>b</sup>
L	O	1	0.92	1
tan <sup>-1</sup> b/a	O		0.87	1
Firmness	O		0.81	1
Color	S		0.63	1 (-)
"Tomato-like"	S	2	0.85	2
"Overall" flavor	S		0.77	2
Sweetness	S		0.59	2
Preference	S		0.49	2
Juiciness	S		0.43	2
Acidity	S		0.10	6
Soluble solids	O	3	0.89	3
Moisture	O		0.81	3 (-)
Weight	O		0.30	3,4 (-)
"Off-flavor"	S		0.11	6
Ripening method	O	4	0.72	4
ΔE	O		0.54	4
Ascorbic acid	O		0.43	3,4
pH	O	5	0.70	5
Titrateable acidity	O		0.70	5 (-)

<sup>a</sup> O = objective measure; S = sensory measure.

<sup>b</sup> Variables with rotated loadings > 0.35 for a factor. Negative loadings are indicated by (-).

From Resurreccion, A. V. and Shewfelt, R. L., *J. Food Sci.*, 50, 1985.  
 With permission.

historically have been evaluated in terms of their viscosity, consistency, and chemical composition (e.g., TS, SS, WIS, pectins). In-plant quality-assurance practices routinely involve measurement of diluted paste or juice Bostwick, soluble solids, and perhaps total solids and serum viscosity. Evaluation of the textural properties of more solid products such as diced, crushed, and whole peeled tomatoes is still in its relative infancy. With consumer attraction to salsa and ethnic foods and the subsequent rise in market share in the diced tomato category, textural integrity has become a significant factor in quality assessment. In practice, as a quality control tool the tomato industry frequently uses methods of texture evaluation that are quite subjective and often involve visual examination and/or probing or squeezing with the fingers. A scant few companies presently use objective methods such as the Shear Press or

puncture test for evaluation of either raw or processed tomato products.

The textural quality of processing tomatoes is rarely evaluated on incoming loads, in general processed product texture is measured after the fact. In addition, although varieties may be processed separately, the raw material is rarely sorted for textural quality or maturity differences prior to processing. Following bulk production of a product such as diced tomatoes, textural properties may be evaluated at the time of remanufacture or formulation of higher value products, but at this point it is impossible to recover losses in textural integrity. In order to distinguish higher value products containing diced, crushed, or whole peel tomatoes, it would behoove the processor to institute routine methods for evaluation of the textural properties of raw and processed products. Perhaps if standards were better defined and less



**TABLE 8**  
**Classification of Methods Available for Evaluation of Textural Properties of Tomatoes<sup>a</sup>**

Test name	Type of test			Classification				Measured variable	Dimensional units	Tomato product application
	Sensory	Objective Destructive	Objective Non-Destructive	Fundamental	Empirical	Imitative	Principle			
Intensity rating	x	x				x	Intensity	Numerical	0 = absence 7 = high	All
Hedonic scaling	x	x				x	Degree of liking	Numerical	0 = dislike extremely 9 = like	All
Texture profile	x	x				x	Intensity, order of changes	Numerical, descriptive	Scales of 1 to 5 through 9, rate, descriptive	All
Puncture		x				x	Force	Force	$mN^{-2}$	Whole peeled stewed diced
Flat plate compression		x	x			x	Force	Force	$mN^{-2}$	crushed Raw (whole) whole peeled
Extrusion		x				x	Force	Force	$mN^{-2}$	stewed diced Stewed diced
Multiple measuring (shear press, etc.)		x				x	Multiple	Force, distance, time	$mN^{-2}, l, t$	crushed purée formulated Whole peeled stewed diced
Drained weight		x				x	Time	Volume	ml	formulated Raw stewed diced
Bostwick consistometer		x				x	Distance	Length	/	crushed purée formulated Juice catsup sauce paste

**TABLE 8 (continued)**  
**Classification of Methods Available for Evaluation of Textural Properties of Tomatoes<sup>a</sup>**

Test name	Type of test			Classification					Measured variable	Principle	Dimensional units	Tomato product application
	Sensory	Objective Destructive	Objective Non-Destructive	Fundamental	Empirical	Imitative						
Adams consistometer		x			x				Distance	Length	/	Catsup sauce purée
Stormer consistometer		x			x				Time	Time	t	paste Juice catsup sauce purée
Blotter test		x			x				Distance	Area	l <sup>2</sup>	Catsup sauce purée
Serum separation test		x			x				Distance	Volume	l <sup>3</sup>	Catsup sauce purée
Ostwald viscometer		x			x				Time	Time	t	paste Serum
NMR imaging		x	x		x				Magnetic resonance	Magnetization phase distribution	g (φ)	Raw (whole) whole peeled stewed diced crushed juice purée
Resonance (dynamic oscillation)			x			x			Resonance vibration	Frequency	Raw phase angle (φ), amplitude (ψ)	Raw (whole) whole peeled stewed diced crushed
Creep compliance			x			x			Force	Compliance	Strain (ε), applied stress (sigma)	Raw whole peeled stewed diced crushed formulated

Microstructure	x	x	Magnification	Area, volume, descriptive	12, 13	Raw (whole) whole peeled stewed diced crushed purée formulated All
Chemical methods (e.g., TS, SS, WIS, soluble pectin, DP, DE, PG, PE)	x	x	Chemical	Concentration	Dimensionless (%)	

<sup>a</sup> Adapted from Bourne, M. C., Texture. *Encyclopedia of Food Science, Food Technology and Nutrition*, 1993. With permission.

subjective more attention would be paid to textural integrity. On the other hand, efforts to optimize the textural properties of tomato products will offer a marketing advantage to savvy processors.

#### IV. TOMATO BIOLOGY

The commercially cultivated forms of tomato belong to the species *Lycopersicon esculentum*, Mill. In 1893 in the U.S., as the result of a tariff dispute, the tomato was officially proclaimed by the Supreme Court a vegetable (Margen and Letter, 1992). Nevertheless, botanically the tomato is a *fruit* of the genus *Lycopersicon*.

Transversal sections of a tomato fruit reveal from 2 to 25 locules (Salunkhe et al., 1974). Most of the world's tomatoes, including processing tomatoes (cultivars used for canning, freezing, drying, etc.) are grown under nonlimiting light conditions for most of the year. Under these conditions, multilocular fruit (Figure 7) can be easily grown (Davies and Hobson, 1981).

##### A. Tomato Shape and Size

The shape of an individual tomato fruit is largely genetically determined, with some influence of environmental and nutritional conditions.

Tomato shape varies greatly, depending on the cultivars; commonly fruits are elongated or pear-like, oblate, or spherical. Typically, processing tomatoes are pear shaped; it is common to find globular and oblong fruits. However, the diversity of fruit shapes are exemplified in Figure 8, which presents 12 cultivars of tomatoes used by Janoria and Rhodes (1974) for tomato juice preparation.

##### B. Tomato Anatomy

The tomato is a fleshy fruit, specifically, a berry. Most of the flesh or juicy tissue of the mature fruit is derived from the placenta (Fahn, 1974); the placenta constitutes the ovule-bearing region of the ovary of the flower (Esau, 1953). In the tomato, as in many but not all fleshy fruits, the mature ovary wall (the pericarp) is not highly differentiated, and a distinct exocarp, mesocarp, and endocarp are lacking. Figure 9 is a diagram of a transverse section of a mature tomato fruit showing the various structures and regions. Pericarp includes the skin, peripheral pericarp, radial arms, and columella.

Tomato "skin" or peel is composed of a thin layer of heavily cutinized epidermal cells and two or more layers of relatively small, flattened cells referred to by some authors as hypodermal cells (Chu and Thompson, 1972; Reeve, 1970). Cells

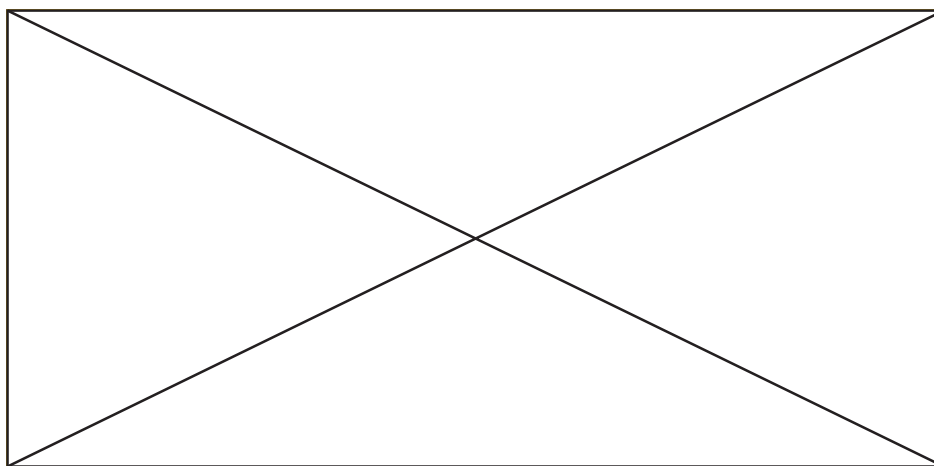

**FIGURE 7.** Multilocular fruit grown under nonlimiting light conditions. (From Davies, J. N. and Hobson, G. E., *Crit. Rev. Food Sci. Nutr.*, 15, 3, 1981.)

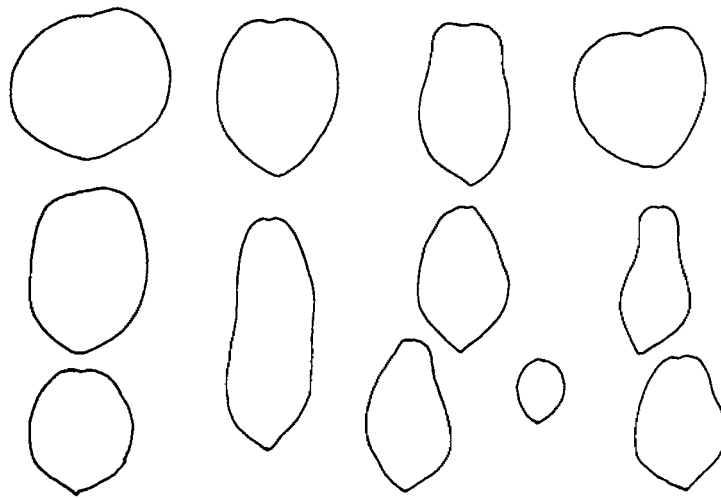

**FIGURE 8.** Variation in fruit shape and size of 12 cultivars. (From Janoria, M. P. and Rhodes, A. M., *Euphytica*, 23, 1974.)

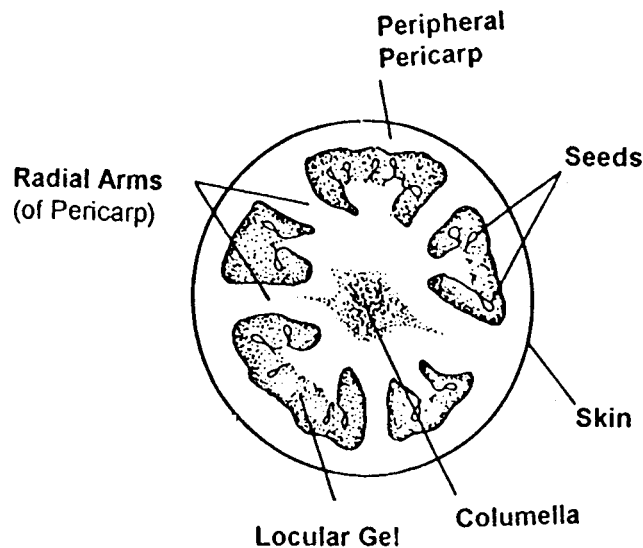
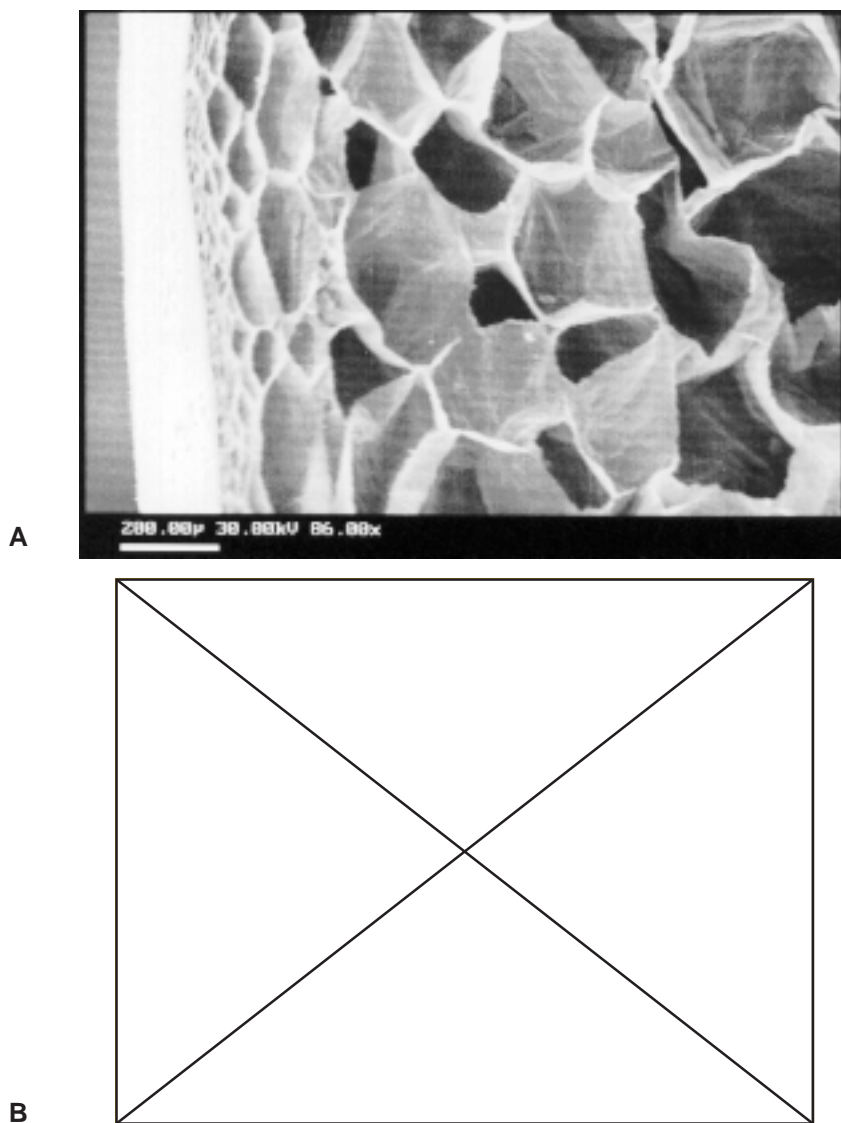

**FIGURE 9.** Internal structure of a tomato fruit.

of the skin are thicker walled than the parenchyma cells of the main portion of the pericarp. Lining the locules is a layer of thin-walled cells, which constitutes the inner epidermis (Esau, 1953; Fahn, 1974; Gould, 1992).

Cells located in the main portion of the pericarp (central part of the peripheral pericarp; see Figure 9) are much larger than skin cells; they have thin walls and are separated by many intercellular spaces. Often pericarp cells are polyhe-

dral; both cell size and cell shape vary. Those cells beneath the skin (Figure 10A) and adjacent to the inner epidermis lining the locules (Figure 10B) are much smaller than cells in the central portion of the peripheral pericarp. Peripheral pericarp parenchyma cells of mature green tomatoes measure 300 to 500  $\mu$ m or more across; their cytoplasm appears as a thin layer that surrounds a central vacuole, and the cell walls are relatively thick (Grierson and Kader, 1986). In



**FIGURE 10.** Electron micrograph of tomato cells.

the micrographs of ripe processing tomato presented in Figure 10A,B some of the largest cells are over 700  $\mu$ m across. Vascular bundles are distributed throughout the pericarp. They run from the stem end to the blossom end in both the peripheral pericarp and the columella (Davies and Hobson, 1981). Locular cavities of the ripe tomato fruit are filled with a jelly-like material and seeds. In the early stages of development, the tomato fruit locules are filled by an outward growth of parenchymatous placental cells and the seeds are surrounded by them. This tissue is not fused with either the adjacent pericarp or the seeds, but

instead presses against these structures. While firm and compact at first, the intruding parenchymatous tissue becomes gelatinous with fruit maturation, as cell walls thin and eventually rupture to produce the locular gel (Brecht, 1987; Davies and Hobson, 1981; Salunkhe et al., 1974).

The overall thickness of the pericarp was determined in 10 cultivars of processing tomatoes grown in California (Barrett and Garcia, 1996); results are presented in Table 9. Pericarp wall thickness does not necessarily increase with fruit weight; in some cultivars, small fruit may have quite thick walls. There is a large variation of

**TABLE 9**  
**Variation of Fruit Weight and Pericarp Thickness of Ten Processing Tomatoes at Three Maturity Stages**

Variety	Maturity stage	Fruit weight (g)		Wall thickness (mm)	
		min – max	Average	min – max	Average
BOS 8066 (Orsetti)	R	65–115	92.8	5.3–7.8	6.9
	R + 2	43–114	70.0	5.0–7.1	6.0
	R + 3	50–104	76.1	4.8–6.2	5.5
Brigade (Asgrow)	R	60–86	73.2	6.2–8.6	7.3
	R + 2	63–87	75.7	5.1–8.4	7.4
	R + 3	66–80	73.5	5.9–7.5	6.8
FM 9208 (Ferry Morse)	R	64–93	80.8	5.9–9.4	7.7
	R + 2	57–82	72.7	6.9–9.6	8.2
	R + 3	54–104	78.7	5.9–8.6	7.2
H 3044 (Heinz)	R	45–82	62.1	4.4–8.2	6.1
	R + 2	44–84	67.5	4.9–7.5	6.2
	R + 3	49–81	65.5	3.5–6.5	5.5
H 8892 (Heinz)	R	62–89	74.7	5.7–8.8	7.0
	R + 2	63–78	70.3	5.2–6.8	6.0
	R + 3	58–105	81.3	5.7–8.8	7.2
H 9280 (Heinz)	R	50–106	72.8	5.2–9.3	7.0
	R + 2	57–93	72.0	5.8–8.1	6.9
	R + 3	49–138	74.2	5.1–7.9	6.9
LaRossa (Rogers)	R	71–105	83.0	6.5–9.4	7.6
	R + 2	53–91	70.0	6.2–7.9	7.2
	R + 3	50–112	76.1	5.9–8.4	7.0
Sun 6117 (Sun Seeds)	R	70–127	88.0	5.1–7.4	6.7
	R + 2	78–116	93.4	5.9–8.0	7.0
	R + 3	61–91	77.8	5.4–7.3	6.6
Halley 3155 (Orsetti)	R	85–130	100.9	6.2–9.1	8.1
	R + 2	61–96	83.4	5.8–8.1	7.3
HyPeel 45 (Peto Seed)	R	68–105	91.3	6.6–8.9	7.6
	R + 2	43–79	62.8	6.1–7.6	7.0

*Note:* All tomatoes were grown simultaneously and under the same agronomic conditions. R = red stage/USDA stage 6; R + 2 = 2 weeks after red stage; R + 3 = 3 weeks after red stage.

pericarp thickness in the same cultivar and maturity stage. As shown in Table 9 fruit of the cultivar H 3044 had pericarp between 3.5 to 8.2 mm thick, considering the three maturity stages together; that was the highest variation (186%) of pericarp thickness observed. Moreover, the maturity stage and fruit weight do not seem to consistently affect the variation of pericarp thickness; some of the thinnest pericarp walls were found among the ripest (Red + 3 weeks) fruit of the cultivars BOS 8066 and H 3044. For 6 of the 10 cultivars studied, the pericarp thickness decreased (7.9 to 20%) with maturity; therefore, there may be a genetic effect on pericarp thickness.

Knowledge of tomato anatomy is a prerequisite to accurate sampling for texture evaluation. A structural feature that has to be considered when texture measurements, such as whole fruit deformation, are to be performed is the presence of radial arms of pericarp (Figure 9). Both the number of radial arms present, as well as their thickness, are expected to impart resistance to fruit deformation, while the locular cavities, which are filled with jelly in the ripe fruit, are much less resistant to deformation.

In evaluating whole fruit deformation (uniaxial compression), it is important to be conscious of the position of the radial arms. The stresses that

occur in tomatoes during this type of test are not evenly distributed due to geometrical factors that result from structural nonuniformity. In our studies we have chosen either to arbitrarily position fruit and evaluate deformation every 45°, or to studiously avoid radial arms in evaluation.

It is somewhat common practice to trim pieces of tissue (cylinders, disks), in particular pericarp tissue, in order to perform texture measurements. It is important to highlight the natural variation of cell size, as seen in Figure 10A and B. In trimming we eliminate some structures that might offer more or less resistance in a puncture test. Also, in trimmed samples it becomes more difficult to perform tests observing the same orientation of the tissue, which might create nonreproducible results. As a general rule, we consider trimming a nonrecommended practice.

### C. Tomato Classification

According to the U.S. Standards USDA, 1975, fresh market tomatoes are classified on the basis of color, into six ripening stages (see Table 10). In California processing tomatoes are typically harvested when 90% of the field is at the red stage.

Examination of internal morphology of sliced fruit can also be used to assess maturity of mature green tomatoes. Observation of locular gel formation allows classify green tomatoes in four physiological stages, as described in Table 11.

Tomato fruit maturity has also been determined nondestructively with nuclear magnetic resonance imaging, NMR (Saltveit, 1991). Changes in the locular content (liquefaction or gel

formation) and softening of the pericarp (observed as a decrease in pericarp wall density; graininess) can be seen in NMR images. Yet NMR imaging is not applicable to sorting of mature green tomatoes due to the length of time required to produce the image.

Other nondestructive techniques have been studied with the purpose of determining fruit maturity, among them X-ray computed tomography (Brecht, 1991), transmission of sound (Abbott et al., 1968; Saltveit et al., 1985), changes in the vibrational response of the fruit (Stephenson et al., 1973), transmission of visible light (Worthington et al., 1973), and delayed light emission (Abbott et al., 1986; Chuma et al., 1982).

### D. Tomato Ripening

Ripening of tomato fruit involves dramatic changes in color, texture, aroma, flavor, and composition. At the onset of ripening, following a rise in ethylene production, respiration begins to increase and initial color changes occur in the locular region; chlorophyll is replaced by carotenoids, mainly lycopene. Tomatoes typically ripen from the “inside-out”, that is, internal color development and tissue softening precede changes in external color and firmness, and ripening progresses from the central columella region down to the blossom end and up to the stem scar. At the breaker and light-red stages  $\alpha$ - and  $\beta$ -carotene reach peak concentrations; in the ripe fruit lycopene accounts for 50 to 76% of the total carotenoid pigments (Davies and Hobson, 1981).

**TABLE 10**  
**USDA Tomato Classes**

Score	Class	Description
1	Green	Fruit surface completely green, varying from light to dark green
2	Breaker	First appearance of external change in color; pink, red, or tannish yellow color on not more than 10% of fruit surface
3	Turning	Over 10% but not more than 30% fruit surface is red, pink, or tannish yellow
4	Pink	Over 30% but not more than 60% pinkish or red
5	Light red	Over 60% surface shows pinkish-red or red, but not more than 90% red
6	Red	Over 90% red; desirable table ripeness

*Note:* All percentages refer to both color distribution and intensity.

Copyright© 1998, CRC Press LLC — Files may be downloaded for personal use only. Reproduction of this material without the consent of the publisher is prohibited.



**TABLE 11**  
**Scoring of Mature Green Tomatoes by Examination**  
**of Sliced Fruit**

Score	Gel formation	Locule color change
M1	None	None
M2	At least in one locule, but not all locules	None
M3	All locules	None
M4	All locules	Red in one or more locules

Modified from Brecht, 1987; Shewfelt and Prussia, 1993.

Ultrastructural studies revealed important changes during ripening at the cell wall-middle lamella level. Initially, there is solubilization of the cell wall; as ripening continues the wall solubilization is more extensive, leading to fragile walls in very ripe fruit.

Production of aroma and flavor compounds also occur during ripening; more than 200 volatile constituents have been described. A major contribution to the tomato taste is imparted by the accumulation of sugars (48% of dry matter in ripe tomato) and the presence of organic acids (13% of dry matter), mainly citric (9% of dry matter). Pectic polysaccharides, which represent approx. 35% of the cell wall composition, correspond to 7% of the ripe tomato fruit (dry basis) (Grierson and Kader, 1986).

## V. TEXTURAL PROPERTIES OF RAW TOMATOES

### A. Factors Affecting Tomato Texture

Factors that affect the textural properties of processing tomatoes may be categorized as either production-related or tissue-specific factors. Production-related factors have been discussed by Bourne (Bourne, 1983) and Jackman (Jackman, 1995) and include: (1) cultivar or variety, (2) maturity at harvest and degree of ripeness, (3) cultural practices, including use and type of fertilizer, application of certain hormones, amount of water and degree of sun exposure, and (4) environmental stresses on the tomato plant prior to harvesting, such as drought, salinization, water,

chilling, and freezing stresses. The effects of variety, maturity, cultural, and environmental factors on textural properties are discussed in greater detail in this section.

It should be noted here that, in growing tomato plants, the destination of labile assimilates (dry matter) from leaves and other sources of supply to growing tomato fruits changes during plant growth (Atherton and Rudich, 1986). The source/sink relationship of supply and demand for assimilates is dynamic and complex and is strongly influenced by environmental conditions. Competition exists between developing fruit, stem, and roots, and also between trusses and between fruit on the same truss. Therefore, on any one plant, ripening of an individual tomato fruit will depend on its location on a specific truss, the location(s) of assimilate sources, and environmental conditions.

Varietal differences exist between the time period from which proximal fruit on the first truss (crown set) are ripe, to the time when the least competitive fruit (typically distal fruit on top truss) are ripe. Because of the fact that tomatoes do not change color significantly once they have reached the red ripe stage (Barrett and Garcia, in preparation) it is difficult to discern by eye maturity differences in fruit on a single plant. Tomato processors typically harvest a field at "90% red ripe", which means that, due to different patterns in assimilate distribution in a single plant, some fruit may have reached the red ripe stage a full 2 to 3 weeks prior to the least competitive fruit. This physiological reality means that the processor inherits a raw material of nonhomogeneous maturity even prior to its leaving the field. In addition,

it explains in part the large variability in red ripe tomato texture observed in most scientific studies.

Tissue-specific or structure related factors (Jackman, 1995) that affect the textural properties of tomatoes include the following: (1) chemical composition of the cell wall, and spatial organization and interaction of the constituent macromolecules in the formation of this structure; (2) activity of softening-related enzymes such as polygalacturonase, pectin methyl esterase and various hyalases; (3) turgor pressure, as dictated by water status, presence of salt gradients and/or cell membrane integrity; (4) cell shape and size distribution; larger cells tend to have greater strain in their walls and are thus somewhat more susceptible to cracking or fracture after application of an external load or with increasing turgor; (5) the amount and distribution of intercellular spaces; and (6) the proportion and arrangement of specialized tissues such as vascular, epidermal, and locular tissues. In addition, the temperature at the time of testing critically affects firmness of both raw and processed products (Bourne, 1982; 1986); therefore, measurements should be conducted in a narrow temperature range.

Due to the scarcity of data reported in the literature on processing varieties, studies on fresh market tomato varieties will supplement the following discussion. The authors realize that production conditions, and in particular ripening regimes for fresh market and processing tomato varieties are quite different, but the two genetic variants do share many similarities. Therefore, it is of interest to review research on fresh market varieties in addition and reference will be clearly made as to tomato type in the discussion.

## **B. Textural Properties of Red Ripe Whole Tomatoes and Specific Anatomical Tissues**

### **1. Whole tomatoes**

Recently, our laboratory carried out comparative varietal evaluations on red ripe fresh market tomatoes, using the Instron Universal Testing Machine for nondestructive flat plate compression of whole fruit and destructive puncture test-

ing of equatorial slices from the same fruit. The objective of the study was to determine the contribution of three distinct anatomical regions (pericarp, columella, and radial arms) to the overall textural properties of whole fruit. Slice analysis of the specific anatomical tissues, and correlation with whole fruit texture are discussed in the next section, while whole fruit measurement is highlighted here. Thirty-six tomato varieties were evaluated, and, to maintain confidentiality, the varieties were arbitrarily coded with letters from A through CC. Twelve of the varieties were picked green and allowed to ripen in air, and these are designated by a (G) following the variety code. Of these twelve, eight were also picked red ripe; therefore, a comparison of textural properties is possible.

Whole fruit samples were placed in the custom brace described above (see discussion of flat plate compression in radial mode,  $n = 4$ ) and subjected to an initial preload of 0.1 kg and total load of 1.0 kg. Resultant delta deformation (deformation at maximum load — deformation at preload) was recorded in mm. Figure 11 is a scatter plot of delta displacement vs. fruit ranking from firmest to softest fruit. This plot shows the spread of the data by variety as well as clustering and outliers. ANOVA testing (one factor) of this data set (mean delta displacement vs. fruit firmness ranking) was significant at  $p = 0.0001$ , and results of LSD testing ( $p = 0.05$ ) of multiple comparisons are summarized in Table 12.

Although the spread in the data for each variety and each individual fruit within a variety is not insignificant, to some extent this reflects normal variation in biological systems. In addition, a decision was made to take four readings per fruit at 45° rotations, and the starting point was randomly chosen to simulate consumer evaluation at point of purchase. It is obvious that measurements made by compression over radial arms will give different results (firmer, therefore smaller delta displacement) than those made over large locules (softer, therefore larger delta displacement). A consequence of this decision is a relatively high standard deviation.

Despite the relatively high standard deviation, the data set could be divided into 20 statistically different groups. It was possible to assign

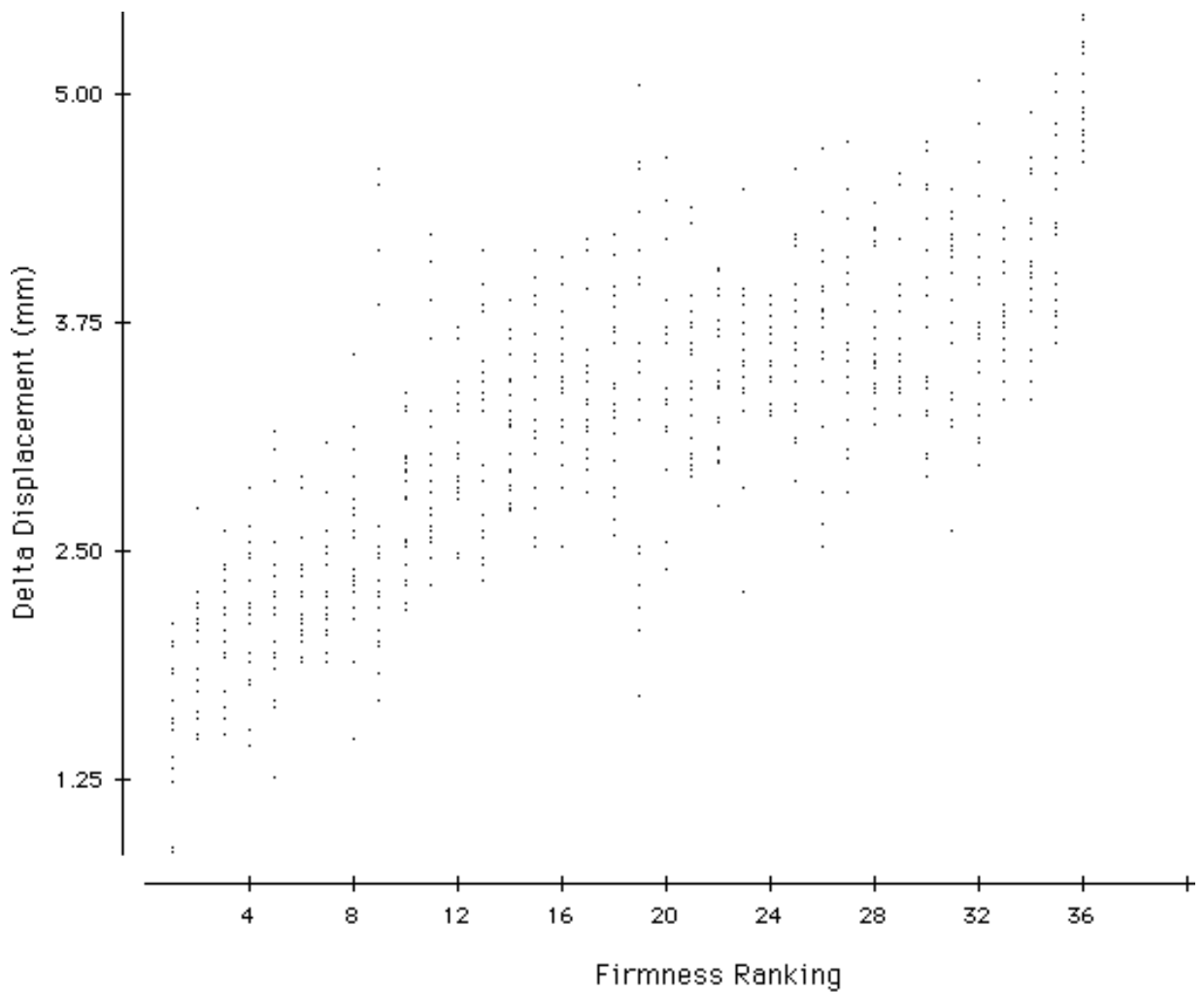

**FIGURE 11.** Scatter plot of delta displacement vs. sensory ranking for whole tomato fruit.

sensory “finger feel” categories, based on the correlations determined earlier in the validation study (see discussion in flat plate compression section above) between delta deformation values and sensory finger feel. The average values (mm) and standard deviations of delta deformation for each category were determined to be as follows:

- |    |                |               |
|----|----------------|---------------|
| 1. | Hard           | 0.859 (0.164) |
| 2. | Very firm      | 1.540 (0.385) |
| 3. | Firm           | 2.361 (0.748) |
| 4. | Firm with give | 3.556 (0.762) |
| 5. | Soft           | 3.756 (0.512) |

Comparison of the eight varieties that were both picked green and allowed to ripen and picked

red ripe yielded interesting results. Of the eight, in five cases the green fruit were firmer than the red, in one case the green fruit was softer than the red, and in two cases the green and red fruit did not differ significantly in firmness.

## **2. Specific Anatomical Tissues**

### **a. Pericarp Tissue**

In an effort to standardize measurements of textural properties, many investigators have concentrated on evaluation of pericarp tissue, typically taken from the equatorial region of the tomato. Pericarp disks are commonly obtained using

**TABLE 12**  
**Whole Tomato Fruit Rankings by Nondestructive Flat Plate Compression**  
**and Sensory Analysis**

Arbitrary variety code	Whole fruit firmness ranking	LSD Results	Mean delta displacement (mm)	Finger feel categories
A(G)	1	A	1.64	Very firm, Firm
B(G)	2	B	1.96	Firm
C(G)	3	BC	2.06	Firm
D	4	BC	2.21	Firm
E	5	BC	2.22	Firm
A	6	BC	2.26	Firm
G	7	CD	2.31	Firm
H(G)	8	DE	2.60	Firm
I	9	E	2.65	Firm
J	10	EF	2.77	Firm
K(G)	11	FG	3.04	Firm, Firm w/give
L	12	GH	3.08	Firm, Firm w/give
M(G)	13	GHI	3.16	Firm w/give
N	14	GHIJ	3.21	Firm w/give
O(G)	15	GHIJK	3.33	Firm w/give, soft
P	16	HIJKL	3.38	Firm w/give, soft
H	17	IJKL	3.39	Firm w/give, soft
Q	18	IJKLM	3.41	Firm w/give, soft
R(G)	19	IJKLM	3.44	Firm w/give, soft
S(G)	20	JKLMN	3.46	Firm w/give, soft
S	21	JKLMNO	3.47	Firm w/give, soft
T	22	JKLMNOP	3.50	Firm w/give, soft
U	23	JKLMNOP	3.51	Firm w/give, soft
V	24	KLMNOPQ	3.60	Firm w/give, soft
K	25	LMNOPQ	3.67	Firm w/give, soft
W	26	LMNOPQ	3.67	Firm w/give, soft
X	27	MNOPQ	3.70	Firm w/give, soft
Y	28	NOPQR	3.74	Firm w/give, soft
Z	29	OPQR	3.76	Firm w/give, soft
O	30	PQR	3.78	Firm w/give, soft
M	31	PQR	3.79	Firm w/give, soft
AA(G)	32	QR	3.82	Firm w/give, soft
AA	33	QR	3.85	Firm w/give, soft
BB	34	RS	4.03	Firm w/give, soft
V(G)	35	S	4.31	Soft
CC	36	T	5.00	Soft

a cork borer after cutting the whole fruit open axially and removing the internal columella, radial arm, placental, and locular tissues. In our laboratory we have consciously chosen not to trim pericarp disks to a standard thickness, because of the differing cell types and sizes that naturally exist in the pericarp.

During the last 6 years, a tremendous amount of excellent work has been carried out by Jackman and Stanley at the University of Guelph, utilizing fresh market tomato pericarp tissue disks as a model system (Jackman, 1995; Jackman et al., 1992; Jackman and Stanley, 1992; Jackman and Stanley, 1992; Jackman and Stanley, 1995;

Jackman and Stanley, 1995; Jackman et al., in press). Based on creep tests and analysis of chilled tomato fruit (Jackman and Stanley, 1995), the authors were able to effectively consolidate mechanisms of tomato softening into one fundamentally solid physico-mechanical model. Their conclusions are discussed below and summarized in Table 13.

Recently, we carried out an evaluation of the effects of thermal processing on diced tomato textural integrity that involved evaluation of “raw control” samples for comparison on each day of processing. The experimental design was based on two replicates of the entire process and tomatoes for each process replicate were obtained from separate fields that matured approximately 10 d apart. Textural properties were measured using three different procedures, puncture, compression, and Shear Press. It is interesting to examine the textural heterogeneity of the raw control tomato pericarp disks that were taken from red ripe tomatoes grown in the same field and were carefully sorted such that hue angles were in a tight range from 36 to 40.

The range in raw control peak force values obtained using the puncture test (Figure 12) on red ripe fruit harvested from both fields over an approximate 3 week period was  $551 \pm 186$  g to  $967 \pm 351$  g. Compression test values (Figure 13) ranged from a low of  $3451 \pm 1580$  g to a high of  $6100 \pm 1560$  g. Due to the lack of available fruit, it was only possible to carry out Shear Press

evaluations on raw controls on approximately half of the process days, but values ranged from  $19,760 \pm 539$  g to  $26,290 \pm 312$  g. Attempts to correlate raw control data obtained from the three different texture methods utilized were unsatisfactory, and correlation coefficients had  $r^2$  values of only 0.13 to 0.35. This may indicate either the variability in raw material texture or the fact that each of the three tests utilized may be evaluating slightly different textural properties. In this case, it is important to further investigate the properties evaluated and the limitations in sensitivity inherent to each test.

Although all subsequent process effects were evaluated compared with the raw control harvested from the same field on that particular process day, due to the variability in raw control firmness values process effects were often insignificant. As a result of this variability in the raw material, our laboratory conducted a study the following year to determine the effect of maturity on red color development and textural properties, among other attributes, in seven tomato varieties (Barrett and Garcia, in preparation). It was found that once the red ripe stage was achieved, tomato color did not deviate significantly, even though fruit was overmature; therefore, color was not a sensitive indicator once red ripe maturity was reached. Tomato fruit firmness did, however, change with maturity and decreased as tomatoes ripened from a peak force range of 353 to 661 g at the pink stage to 199 to 303 g at the red ripe

**TABLE 13**  
**Mechanisms Involved in the Softening of Tomatoes<sup>a</sup>**

Textural parameter	Mechanism	Contribution to Softening (%)
Instantaneous elasticity	Turgor pressure	20–35
	Primary wall strength (esp. cellulose)	— <sup>b</sup>
Viscoelastic properties	Hemicellulose composition	10–15
	Pectin composition	20–35
Steady-state viscous behavior	Increased wall fluidity due to Exosmosis <sup>c</sup>	20–35
	Breakdown of cell wall and/or middle lamellar polymers	

<sup>a</sup> Modified from Jackman, R. L. and Stanley, D. W., 1995.

<sup>b</sup> No evidence for contribution to softening.

<sup>c</sup> May be considered as a component of turgor pressure.

## Puncture Summary of Raw Control

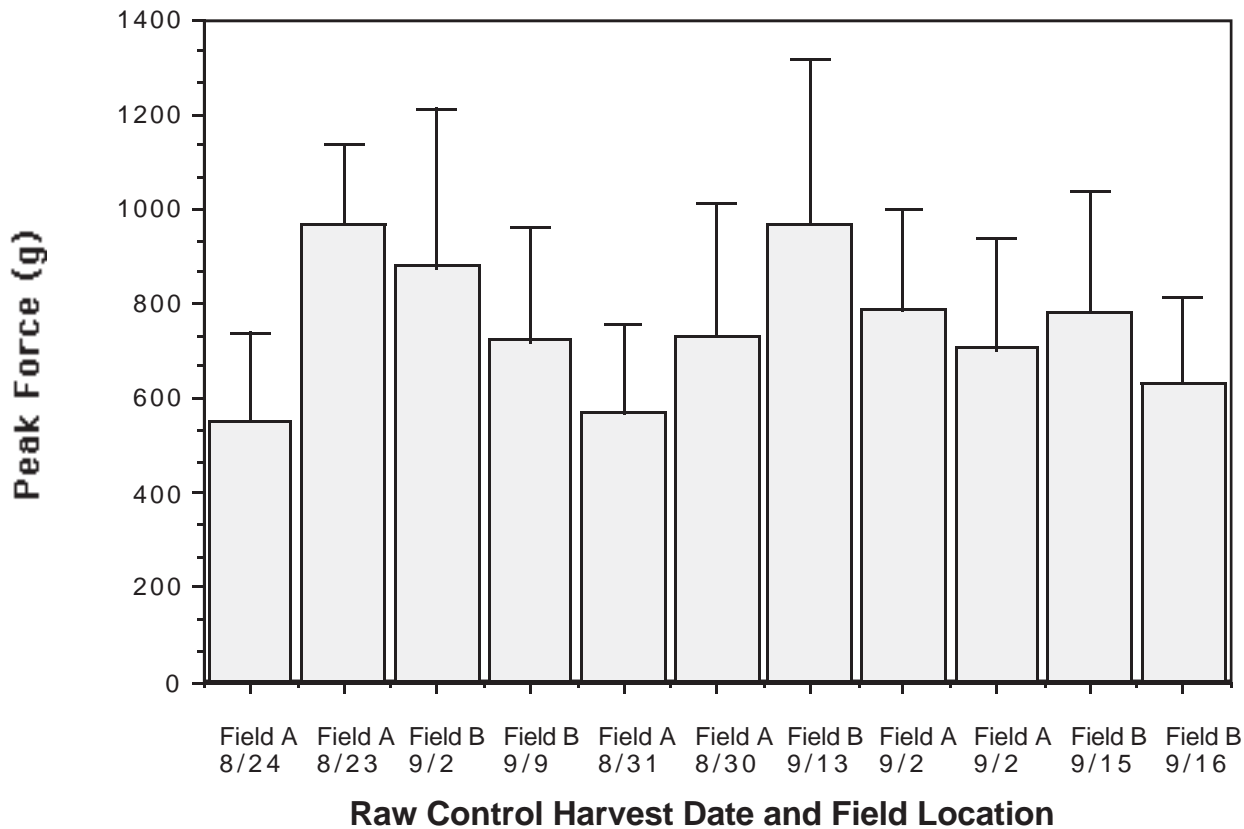

**FIGURE 12.** Firmness of raw control tomatoes as evaluated by puncture tests.

stage, and 189 to 240 g at the overmature stage (Figure 14).

### *b. Other Anatomical Tissues*

The tissue in the stem scar region plays a vital role in support of the fruit structure and typically is the most firm and the least developed in terms of color. Because of physiological differences in ripening rate, different anatomical regions of the tomato will have varying degrees of textural integrity. It is important to keep this variability in mind when sampling tomatoes for experimentation, and to realize that this inherent variability in any single tomato will dictate to some degree the range of textural properties one may encounter in both raw and processed tomatoes.

Holt (Holt, 1970) used an Instron fitted with a puncture probe to evaluate the different anatomical tissues of ripening tomatoes (Figure 15). He found that, as tomatoes ripened, the structural components changed in different ways. The primary peaks observed corresponded to the skin followed by a plateau where the probe passed through the pericarp (flesh), then a smaller inner epidermis peak. As the probe entered the locular area of the tomato, a constant low force was also obtained. The authors observed that force required to penetrate the skin was higher in unripe tomatoes and that inner epidermis peak and pericarp plateau force values were also higher in unripe tomatoes. Pericarp and inner epidermis strength decreased rapidly during the green to late color break stages and then slowed while skin strength fell more progressively.

## Compression Summary for Raw Controls

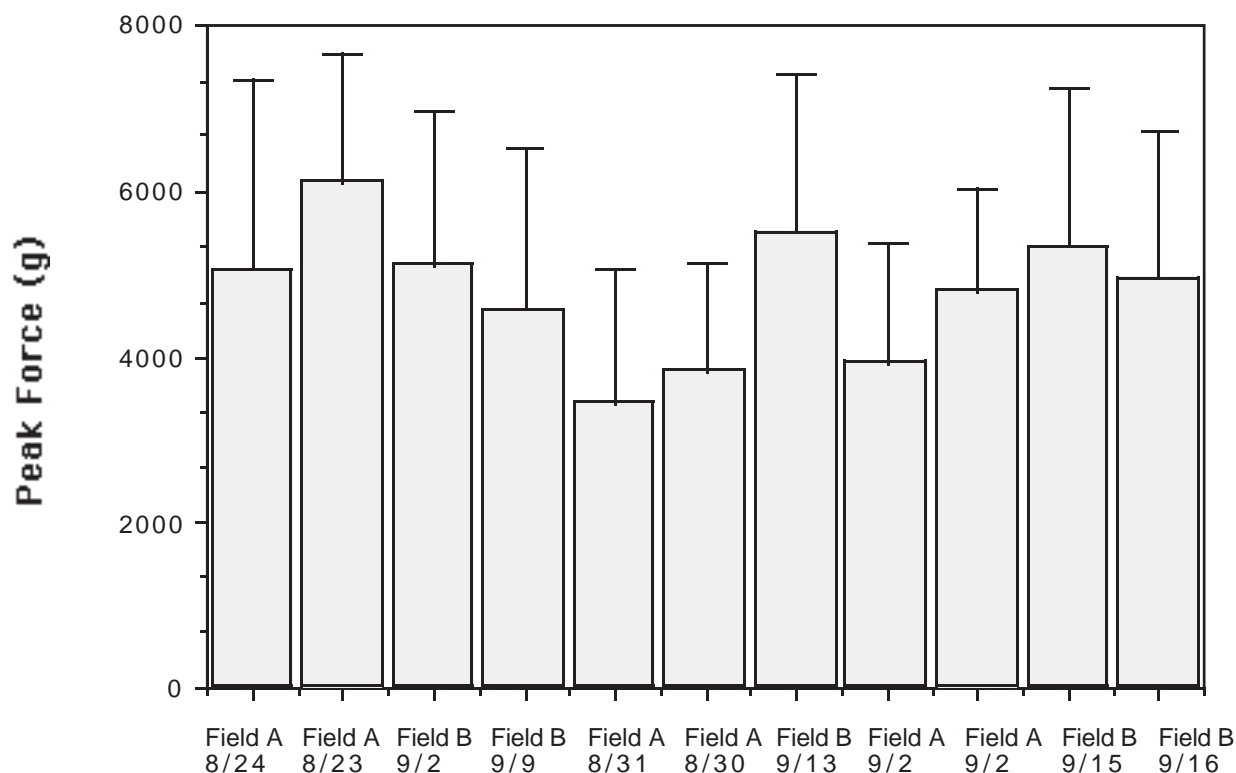

## Raw Control Harvest Date and Field Location

FIGURE 13. Firmness of raw control tomatoes as evaluated by compression tests.

Saltveit (Saltveit, 1991) noted that the alteration in the firmness and consistency of the locular tissue is not detectable by most common methods of nondestructive texture measurement, but it could be discerned using NMR imaging (see discussion above). No external changes in color or appearance could be detected between the mature green 1 and 3 stages, and there was no significant difference in firmness, as determined by flat plate compression (Table 14). Significant changes in whole fruit firmness did, however, occur with ripening. An increase in the NMR image intensity of the locular region, indicating increased water content due to liquefaction, and more ‘graininess’ in the pericarp wall due to decreased density occurred as a result of tomato ripening (Figure 16).

In 1988, Adegoroye et al. (Adegoroye et al., 1988) reported on the correlation of six force-

deformation based characteristics of texture with insoluble protopectin content. A whole fruit puncture test was utilized to obtain the following measurements: (1) deformation, distance (mm) of probe travel from first contact with the tomato fruit surface to the bioyield point; (2) pericarp strength, the force (N) at bioyield; (3) locular resistance, the residual force following bioyield; (4) firmness, the maximum slope of the force deformation curve; (5) compliance, the deformation per unit pericarp strength and (6) toughness, the total energy consumed during puncture, or the area under the force-deformation curve. Fruit size had a significant effect on deformation, pericarp strength and toughness values but not on locular resistance, compliance, and firmness. Pericarp strength, locular resistance and firmness decreased with ripening (Table 15), but toughness was un-

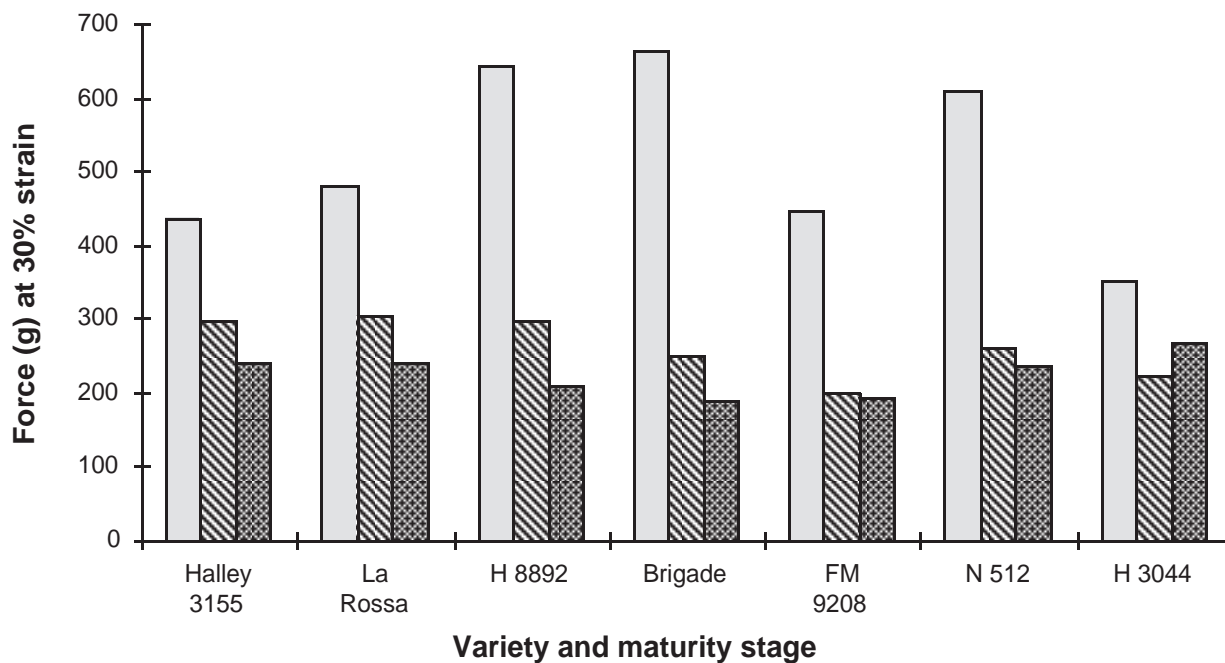

**FIGURE 14.** Firmness of seven varieties of processing tomatoes harvested at the pin, red, and over-mature stages.

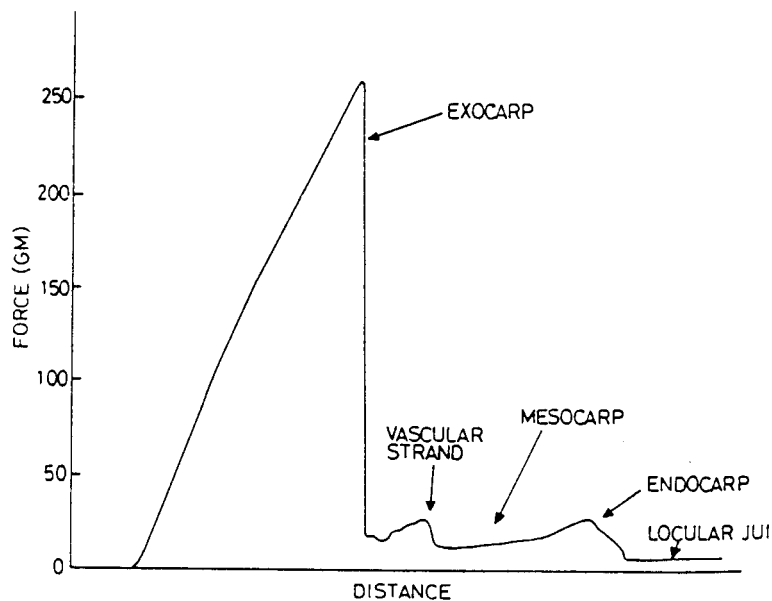

**FIGURE 15.** Instron force-distance curve for penetration through different anatomical regions of the tomato. (From Holt, C., *J. Texture Studies*, 1, 1970.)

affected. While all six force-deformation characteristics measured were significantly correlated with protopectin content, the highest correlation

existed between compliance and protopectin ( $r = -0.88$ ). Both epicarp strength and firmness correlated well with compliance; therefore, the



**TABLE 14**  
**Comparison of Subjective External and Internal Attributes of**  
**Tomato Fruit**

Maturity	External color	Internal maturity	nl C <sub>2</sub> H <sub>4</sub> /(gh)	μCO <sub>2</sub> /(gh)	Firmness
Red-ripe	6 <sup>x</sup>	— <sup>y</sup>	9.8 a <sup>w</sup>	24.5 b	1.8 <sup>z</sup> a
Turning	3	—	5.7 b	23.9 b	1.6 ab
Breaker	2	—	2.6 c	28.8 a	1.3 b
Mature-green	1	3	0.4 d	17.9 c	0.8 c
Mature-green	1	1	0.03 e	11.7 d	0.7 c

<sup>w</sup> Means within each column followed by the same letter are not significantly different by Duncan's multiple range test. *P* = 0.05.

<sup>x</sup> External color subjectively rated as mature-green equals 1, breaker equals 2, turning equals 3, pink equals 4, red-ripe equals 6.

<sup>y</sup> Internal maturity subjectively rated on firmness of locular tissue and color of seeds with 1 being green, firm tissue and seeds cut with sharp knife, and 3 being green, reddish tissue with seeds not cut by knife.

<sup>z</sup> Firmness was measured as the displacement in mm of a 500 g weight resting on the fruit for 10 s.

From Saltveit, M., *Postharvest Bio. and Tech.*, 1, 1991.

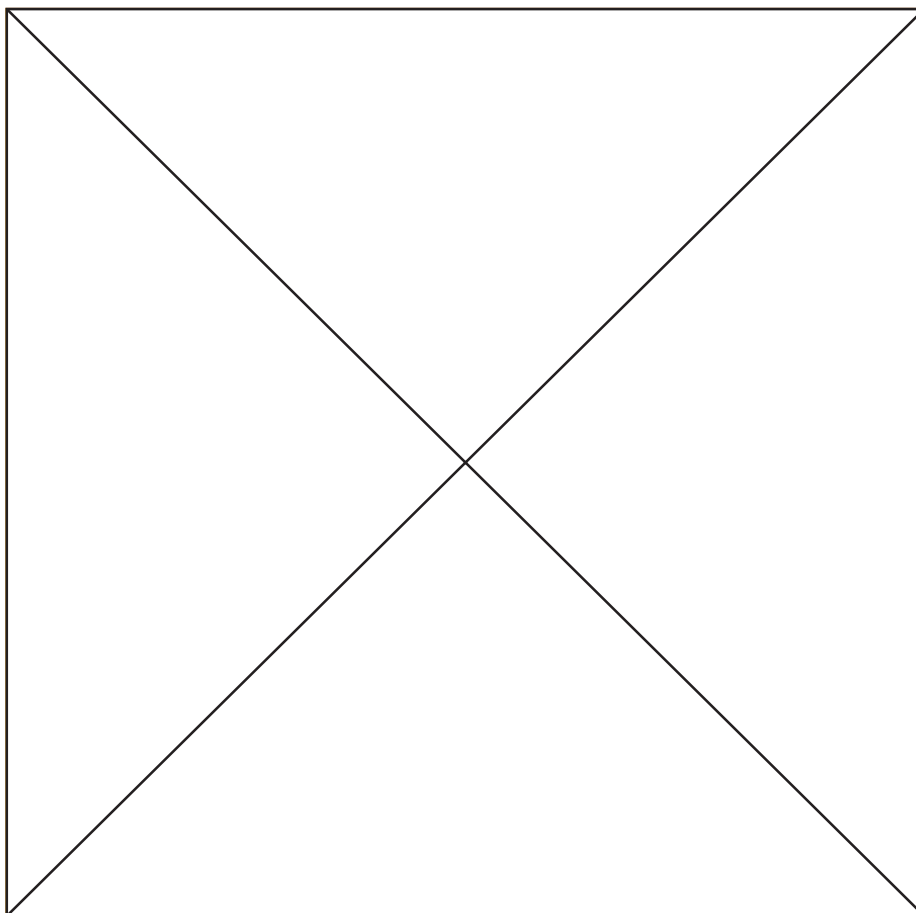

**FIGURE 16.** Comparison between photographs (left) and NMR (right) images of mature green (MG) tomatoes at two stages of development: (A) MG1 and (B) MG3. (From Saltveit, M. E., *Postharvest Biol. Technology*, 1, 1991.)

Copyright© 1998, CRC Press LLC — Files may be downloaded for personal use only. Reproduction of this material without the consent of the publisher is prohibited.

**TABLE 15**  
**Force-Deformation Characteristics and Protopectin Content of Tomato Fruits at Different Stages of Ripeness and Their Correlation**

Factor	Deformation (mm)	Epicarp strength (N)	Locular resistance (N)	Compliance (mm N <sup>-1</sup> )	Firmness (N mm <sup>-1</sup> )	Toughness (N mm)	Protopectin (mg % AUA)*
<i>Ripeness</i>							
Mature-green	12.03 <sup>a</sup>	2.65 <sup>c</sup>	0.50 <sup>d</sup>	4.53 <sup>a</sup>	0.22 <sup>c</sup>	15.84 <sup>a</sup>	20.5 <sup>c</sup>
Turning	12.67 <sup>a</sup>	2.72 <sup>c</sup>	0.40 <sup>c</sup>	4.66 <sup>a</sup>	0.21 <sup>c</sup>	16.92 <sup>a</sup>	20.0 <sup>c</sup>
Pink	14.91 <sup>b</sup>	2.04 <sup>b</sup>	0.13 <sup>b</sup>	7.29 <sup>b</sup>	0.14 <sup>b</sup>	15.17 <sup>a</sup>	18.3 <sup>b</sup>
Firm-ripe	18.16 <sup>c</sup>	1.71 <sup>a</sup>	0.08 <sup>a</sup>	10.55 <sup>c</sup>	0.095 <sup>a</sup>	15.41 <sup>a</sup>	10.1 <sup>a</sup>
<i>Correlation coefficient (R)</i>							
Protopectin	-0.61**	0.79**	0.83*	-0.88**	0.86**	0.53**	—
Compliance	0.72**	-0.91**	-0.84**	—	-0.99**	-0.59**	-0.88**

\* AUA = Anhydrouronic acid

\*\* Significant at P = 0.01.

*Note:* Figures in the column with different superscripts are significantly different ( $P < 0.01$ ) according to Duncan's multiple range test.

From Adegoroye, A. S. et al., *J. Food Sci. Technol.*, 25, 2, 1988.

authors concluded that pericarp strength was a good parameter to evaluate in quick tests. In the case of fruit of varying sizes, locular resistance was a more sensitive measure.

Hall (Hall, 1987) evaluated the firmness of outer (opposite the locules), radial (outer tissue opposite radial arms) and inner (columella) pericarp tissues of several cultivars of fresh market tomatoes at different stages of maturity. Transverse slices were taken midway between the blossom and stem ends and a 4.9-mm flat cylindrical probe was utilized for puncturing the various tissues. Tissue firmness in three fresh market cultivars, 'Walter', 'Flora-Dade', and 'MH-1' was compared 6 d after ripening mature green fruit at 20°C. Hall found that cultivars differed in the relative firmness of the tissues evaluated (Table 16), with 'Walter' being the least firm overall. In addition, while the inner pericarp (columella) tissue was the least firm in 'Flora-Dade' and 'MH-1' cultivars, the inner pericarp was softest in 'Walter'. This study is of interest because it is the first reported use an instrumental texture method to discriminate ripening in different anatomical tissues of tomatoes.

In conjunction with the whole fruit evaluation described above, recently our laboratory carried out puncture testing of tomato slices using a method similar to that of Hall (Hall, 1987), which was described previously (Figure 17). The objective of the study was to determine the contribution of three distinct anatomical regions: pericarp, columella, and radial arms, to the overall textural properties of whole fruit. Thirty-three of the original varieties were picked red ripe, and five varieties were also picked green and allowed to ripen in air ("G" following the sample code).

Simple linear regressions between mean maximum force for each tissue vs. whole fruit firmness ranking were performed. This analysis provided an indication as to how much each tissue contributed to overall whole fruit firmness. We expected and found an inverse relationship between puncture force and delta deformation data. Maximum force values from each of the three tissues tested vs. whole fruit firmness all had an  $r^2 < 0.40$ , suggesting that none of the tissues alone could fully predict the firmness of whole fruit. However, when all tissues were taken together in a multiple regression, the  $r^2$  increased to 0.51.

**TABLE 16**  
**Firmness of Three Fruit Tissues of Three**  
**Tomato Cultivars Ripened at 20°C 6 Days**

Cultivar	Newtons			Cultivar means <sup>z</sup>
	Tissue			
	Outer	Radial	Inner	
Walter	2.0	1.2	1.5	1.63 A
Flora-Dade	2.6	2.4	2.3	2.46 B
MH-1	3.2	2.9	2.4	2.81 B
Tissue means <sup>y</sup>	2.60A	2.25AB	2.06B	—

<sup>z,y</sup> Mean separation by Duncan's multiple range test, 1% level.

From Hall, C. B., *J. Amer. Soc. Hort. Sci.*, 112, 4, 1987.



**FIGURE 17.** Puncture analysis of different anatomical tissues in tomato slices

These results suggest that contributions of each tissue were not additive, and parallel tissue softening may have occurred, as the multiple re-

gression  $r^2$  did not approach 1.00. When data from the radial arms was plotted vs. data from the outer pericarp, the  $r^2 = 0.925$ , suggesting that these

two tissues soften simultaneously and predict each other very well. However, when data from the columella tissue was plotted vs. radial arm data the  $r^2$  value was only 0.49, suggesting that the two tissues do not predict each other well. This would corroborate the theory that columella tissue softens first, followed by softening of outer tissues from the blossom end up to the stem scar. In comparing the firmness of different tomato tissues, Hall (Hall, 1987) found no interaction of tissue type and cultivar, but did not attempt to correlate the firmness of different tissues with each other or compare them to whole fruit measurements.

It is not surprising that the tomato slice tissue analysis did not fully predict whole fruit firmness. The deformation test used for whole fruit subjects intact fruit to a simple, unidirectional stress, but this stress is distributed through a nonsymmetrical, irregular system of anatomical tissues and locular spaces. The spaces allow the fruit to flex and deform differently than it would if it were solid. Puncture testing is much more tissue specific and is a destructive test, while whole fruit deformation is nondestructive. Nonetheless, valuable information concerning variable softening of different anatomical tissues, and the ability to correlate whole fruit and specific tissue softening was obtained from this study.

The contribution of locular material to the textural properties of tomatoes is at present an unknown. Measurement of the locular material is difficult, and often highly subjective, unless one uses a sophisticated technique such as NMR imaging (see discussion above) or physically removes the material and subjects it to either consistency or viscosity determination. Recently, we evaluated a number of processing tomato varieties at different stages of maturity, subjectively evaluated the state of the gel (e.g., hard to soft), physically removed and weighed it and expressed this as a percentage of whole fruit weight (Barrett and Garcia, in preparation).

### C. Effects of Variety and Maturity

Both tomato variety and the stage of maturity at which the fruit is picked are extremely impor-

tant factors influencing the textural properties of processing tomatoes. With the design of the mechanical tomato harvester in the late 1960s, tomato breeders were required to develop varieties that would withstand the additional rough handling incurred during harvest. Thicker pericarp walls, more pericarp tissue, and fewer locules ensured the structural integrity of tomato fruit, and correspondingly resulted in increased the insoluble solids content such that improvements were realized in consistency.

Gould (Gould, 1992) suggested considering the following guidelines when developing and using new varieties for processing:

1. Varieties should be uniform in setting fruit and in ripening with ability to set fruits over a wide range of temperature and climatic conditions.
2. Varieties should be fully resistant to all tomato diseases, insects, and disorders.
3. New cultivars must be adaptable to mechanical harvesting and bulk handling.
4. All tomatoes for processing must be free from blossom end scars and cracking.
5. Tomatoes must be stemless when removed from the vine with stem scars less than 0.25 in (6 mm) in diameter. Further the stem scar should not brown during processing.
6. Tomatoes for peeling should be round to oval in shape, but shape may vary for juice or crushing and products manufacture.
7. Fruit size should be uniform with no fruit smaller than 50 g and none larger than 90 g.
8. Tomato total solids content should be in excess of 5.5% and preferably upward to 8.5%.
9. Tomato soluble solids content (Brix value) should be in excess of 4.5% and preferably upward to 7.5%.
10. Tomato water-insoluble solids content should be in excess of 1% and increasing proportionally with total solids content.
11. Tomatoes should have a high acid (citric) content (minimum of 0.35% and up to 0.55%).
12. Tomatoes should have a low pH value (maximum of 4.4 and preferably all fruits with a pH of 4.2 or less).

13. Tomatoes should be high in Vitamin C content (in excess of 20 mg/100 g).
14. Tomatoes for canning should have skin or peel that removes easily and completely without stripping. Also, they should remain firm and whole (depending on style) after processing.
15. Tomatoes for juice manufacture should have a thick consistency (GOSUC value of 50 or more) after manufacture and the juice should not separate while in the can or jar during shelf life.
16. All tomatoes for processing should have a bright red glossy color after processing, regardless of the processed product.
17. All tomatoes have typical tomato flavor before and after processing with no bitterness or stringent flavor.

The list prepared by Gould is a good general guideline, but unfortunately relatively few varieties

meet all of the criteria stipulated. Since the 1970s the California League of Food Processors has supported research conducted by the Dept. of Food Science at the University of California, which is focused on evaluation of new tomato breeding lines. Materials showing potential as processing varieties are annually submitted by seed companies to replicated and observational trials that are conducted in five different counties throughout California. Following the advent of the mechanical harvester, it was noted in studies carried out in the UCD Dept. of Food Science and Technology that Bostwick values decreased. Combined county averages for quality evaluation of replicated trials carried out in five California counties in 1996 are presented in Table 17.

Marsh et al. (Marsh et al., 1968) evaluated the effects of harvest maturity on the consistency of concentrated tomato products and found that with some varieties, maturity had a significant effect on the viscosity of paste. An increase in total

**TABLE 17**  
**Combined California County Averages for Tomato Quality Evaluation**  
**(Fresno, San Joaquin, Stanislaus, Sutter and Yolo)**

Variety	Counties	°Brix	pH	Avg. Bostwick	% Citric acid	Predicted		
						Paste Bostwick	Paste yield	Catsup yield
AB 4077	All	5.3	4.51	14.58	0.279	4.5	379	895
APT 127	All	5.2	4.56	15.75	0.270	4.8	370	853
ATPX 270	All	4.8	4.59	14.92	0.235	3.8	343	853
BOS 528	All	5.0	4.59	14.72	0.259	4.1	359	873
CXD 181	All	5.0	4.60	16.54	0.265	4.9	354	814
H 8892	All	4.9	4.53	13.41	0.272	3.2	349	915
H 9382	All <sup>a</sup>	5.2	4.58	13.39	0.284	3.7	371	929
H9497	All	4.9	4.62	15.29	0.259	4.1	349	846
Halley 3155	All	5.4	4.50	14.83	0.328	4.8	386	893
HMX 4878	All	5.0	4.64	16.57	0.236	5.0	360	818
HyPeel 108	All <sup>a</sup>	5.2	4.58	17.13	0.261	5.5	371	813
HyPeel 153	All	5.6	4.58	15.45	0.277	5.3	397	883
PSX 32212	All <sup>a</sup>	5.4	4.51	13.87	0.319	4.3	387	926
RPT 1294	SJ, St, Su, Y	5.3	4.66	15.21	0.249	4.8	377	888
RPT 1478	All	4.9	4.57	13.32	0.247	3.1	349	918
Sun 6200	All <sup>a</sup>	5.0	4.55	14.21	0.261	3.8	359	891
Sun 6216	All	5.1	4.55	14.12	0.247	3.9	365	902
Overall averages		5.1	4.57	14.90	0.268	4.3	366	877

<sup>a</sup> One replicate in one county.

solids occurs during the maturation of tomatoes from the below color (Agtron E reading 68 to 100) to the well-colored (Agtron E reading 0 to 46) stages with serum viscosity remaining unchanged or actually decreasing. Because consistency measurements are proportional to both the total solid content and the serum viscosity of the raw material, these may lead to a confounding of results. Paste samples were stored at ambient conditions for 2 and 4 months, and the authors concluded that the effect of maturity on the tendency towards gelation was variety dependent.

Studies carried out in our laboratory during the 1995 and 1996 season show that both variety and maturity significantly affect raw tomato texture, paste consistency, and serum viscosity and the texture of cooked diced tomatoes. In general, texture, consistency, and serum viscosity decline with increasing maturity; however, some varieties “hold” their integrity better than others as they mature in the field. Ease of peel removal is enhanced with maturity, and the number of flags or peel remnants remaining on the tomato following the peel operation is reduced in mature fruit. There is a tradeoff when selecting harvest maturity for whole peel and diced tomatoes between maintenance of textural integrity and ease of peel removal.

Recently, our laboratory carried out a study of the effects of variety and maturity on the textural properties of processing tomatoes. Textural properties of raw fruit were evaluated using both puncture tests on pericarp disks and Shear Press measurements on bulk dice samples. Results of the puncture tests were presented earlier (Figure 12). Raw fruit texture (measured in grams force) was obviously highest at the pink stage, but declined as tomatoes matured. In some varieties there was a rapid decline in firmness between the red ripe and overmature stages, while in others firmness was fairly constant. Because firmness generally declined with maturity, early harvest or perhaps sorting of fruit by maturity would benefit textural integrity.

Bourne (Bourne, 1973) utilized a nondestructive flat plate compression method with a modified penetrometer to evaluate the deformation of two fresh market tomato varieties that were picked green-ripe and held in a ripening room at 18.3°C for 17 d. Figure 18 illustrates that the varieties differed tremendously in terms of absolute deformation values and the change in deformation as ripening progressed. The Heinz variety, which is relatively firm, showed a deformation range from approximately 0.3 to 0.5 mm, while the softer New Yorker variety ranged from about 0.5 to 1.3 mm during the 17-d period. In both cases,

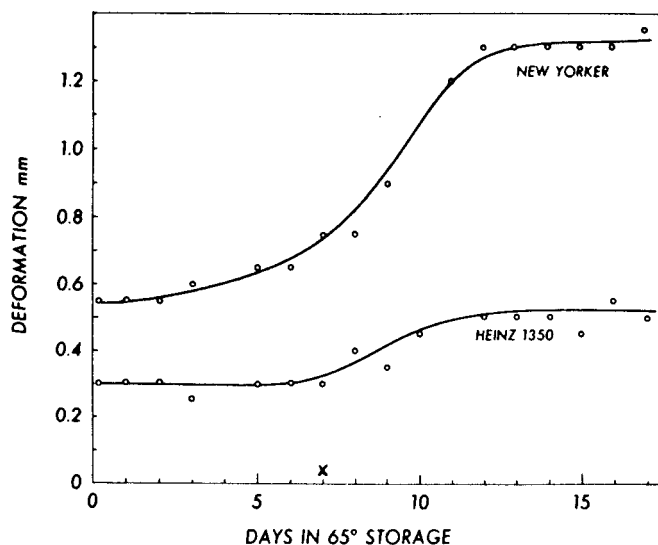

**FIGURE 18.** Deformation changes in two varieties of fresh market tomatoes during ripening and storage. (From Bourne, M. C., *J. Food Sci.*, 38, 1973.)

deformation values were relatively constant after 12 d of storage. The X on the graph marks the day when the first pink coloration appeared on the blossom end.

Another study of the textural properties of fresh market tomatoes at various stages of ripeness was carried out by Kader et al. (Kader et al., 1978). The authors utilized both a nondestructive compression method and a destructive puncture-

type test to evaluate textural properties. Cal Ace tomatoes were picked at various stages of ripeness: (1) mature green, (2) breaker, (3) turning, (4) pink, (5) light red, and (6) red. Tomato firmness declined significantly as ripening progressed, as indicated by both compression (Figure 19) and puncture tests (Figure 20).

It is interesting to compare absolute deformation values obtained in the nondestructive study

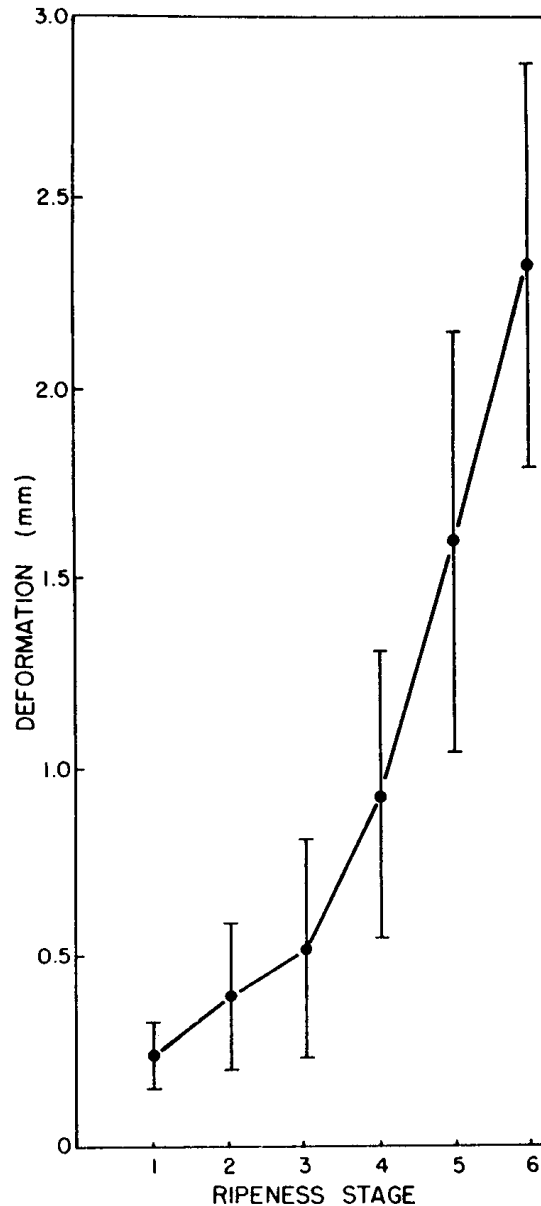

**FIGURE 19.** Firmness of tomatoes during ripening as evaluated using the compression test. (From Kader, A. A. et al., *J. Am. Soc. Hort. Sci.*, 103, 1978.)

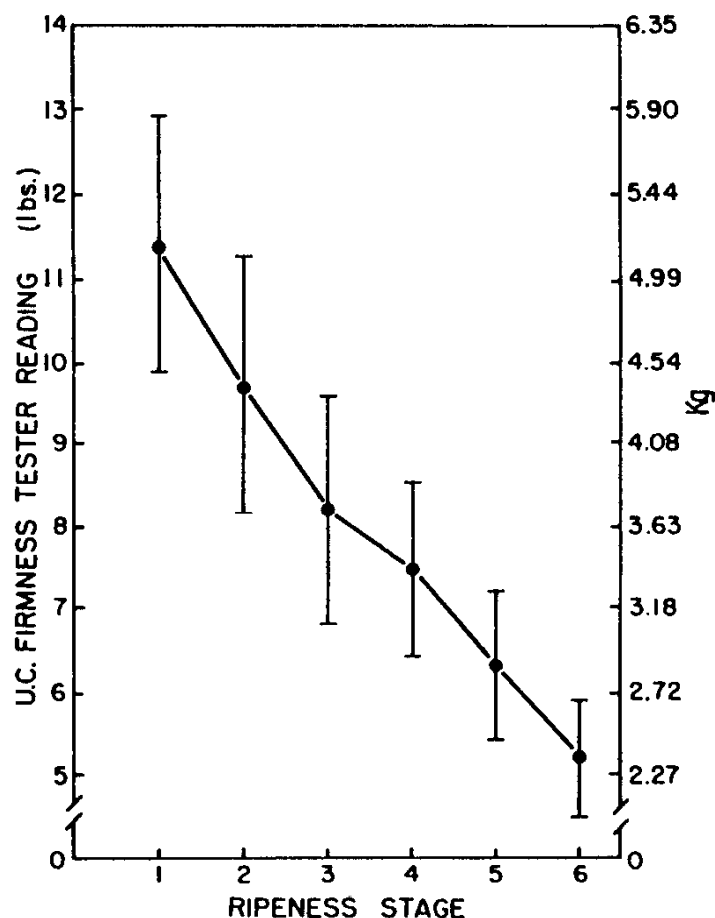

**FIGURE 20.** Firmness of tomatoes during ripening as evaluated using the puncture test. (From Kader, A. A. et al., *J. Am. Soc. Hort. Sci.*, 103, 1978.)

carried out in our laboratory on red ripe whole fresh market tomatoes (see discussion above) to those previously reported for nondestructive measurements by Bourne (Bourne, 1973) and Kader et al. (Kader et al., 1978), as described above. Bourne found that the range in axial mode deformation values during ripening (green to red ripe) of two different varieties was 0.3 to 1.3 mm, as obtained with a modified penetrometer. Kader et al. used a different nondestructive technique in radial mode and correlated this to finger feel categories for light red and red ripe fruit, which ranged from 0.8 mm (very firm) to 2.7 mm (very soft). Our own range of values, as obtained on red ripe fruit using the Instron in radial mode, ranged from 0.9 mm (hard) to 3.8 mm (soft). The greater range and therefore increased sensitivity obtained in our study may have been due to both radial

mode determination, use of the custom brace and a more sensitive instrument (e.g., Instron) for evaluation of textural properties of tomatoes.

Jackman and Stanley (Jackman and Stanley, 1992) found that both puncture and flat plate compression of mature green and red ripe tomato pericarp disks resulted in a typical force-deformation curve (Figure 21). The authors found that, in normal tomato fruit ripening, most of the parameters associated with this curve decrease to a constant and minimum value. Through careful data analysis and visual examinations of pericarp disks, it was possible to conclude that failure mechanisms varied in mature green and red ripe tissues. Failure in mature green fruit appeared to occur through a sequential mechanism involving cell relaxation and concomitant fluid migration from cells, followed by cell rupture. In red ripe tissues,



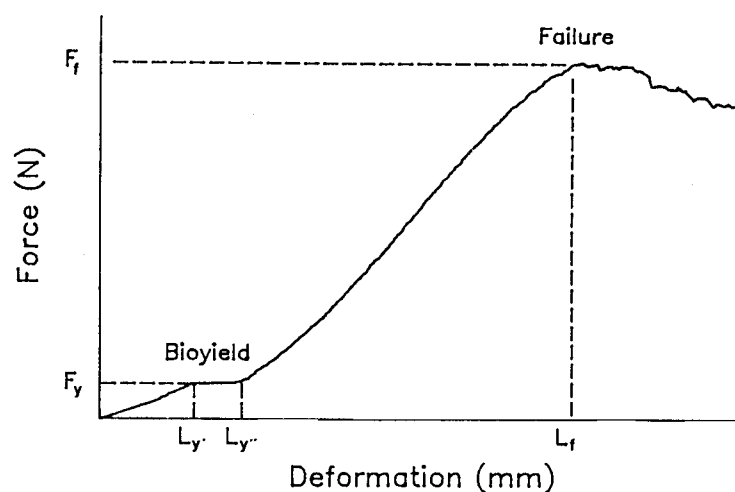

**FIGURE 21.** Typical force-deformation curve for whole tomatoes. (From Jackman, R. L. and Stanley, D. W., *J. Texture Studies*, 23, 1992.)

failure was less distinct and the dominant mode was concluded to be middle lamella degradation and cell de-bonding, with cells remaining intact. This transition in failure mode is depicted in Figure 22 (Jackman and Stanley, 1995).

## D. Effects of Cultural Practices and Environmental Conditions

### 1. Temperature

In an excellent review on tomatoes, Davies and Hobson (Davies and Hobson, 1981) reported that tomato fruit firmness is strongly affected by environmental conditions. Ethylene production, polygalacturonase activity, lycopene, and carotenoid synthesis are all inhibited at temperatures in the range of 30 to 40°C. These authors stated that high-temperature tolerance varies among varieties and with the temperature and time of exposure. In tolerant fresh market varieties, high-temperature injury was still reversible after up to 2 d at 40°C, 4 d at 35°C, or 6 d at 30°C if the tomatoes were transferred to optimum ripening temperatures (20 to 25°C).

In terms of tomato ripening, growing temperatures have a significant effect on ripening rate. Once ripening has been initiated and breaker stage attained, ripening progresses in a predict-

able fashion controlled almost exclusively by ambient temperature because internal levels of endogenously produced ethylene are near saturation levels (Saltveit, 1991).

At the other end of the spectrum, tomatoes are also sensitive to freezing (−1°C) and chilling temperatures (above −1°C and below 12.5°C) (Grierson and Kader, 1986). Symptoms of freezing injury include a water-soaked appearance, softening, and drying of the gelatinous locular material. The severity of chilling injury depends on the exposure temperature and time. Chilling is more likely to occur in green rather than red ripe tomatoes, but symptoms are more noticeable after transfer to ripening temperatures. Symptoms of chilling injury include failure in fruit ripening, irregular ripening, premature softening, surface pitting, seed browning, and increased decay.

Jackman and Stanley (Jackman and Stanley, 1995) used a creep compliance method to evaluate the influence of normal ripening and chilling stress on the viscoelastic properties of fresh market tomato pericarp tissue. Creep behavior was measured on tissue from fruit stored at 22°C (nonchilled) and 5°C (chilled) for 28 d, or at 5°C for 16 d prior to transfer to 22°C for an additional 12 d (prechilled). The authors evaluated four separate compliances (see preceding discussion on creep method) and found that each increased steadily during ripening and contributed to the

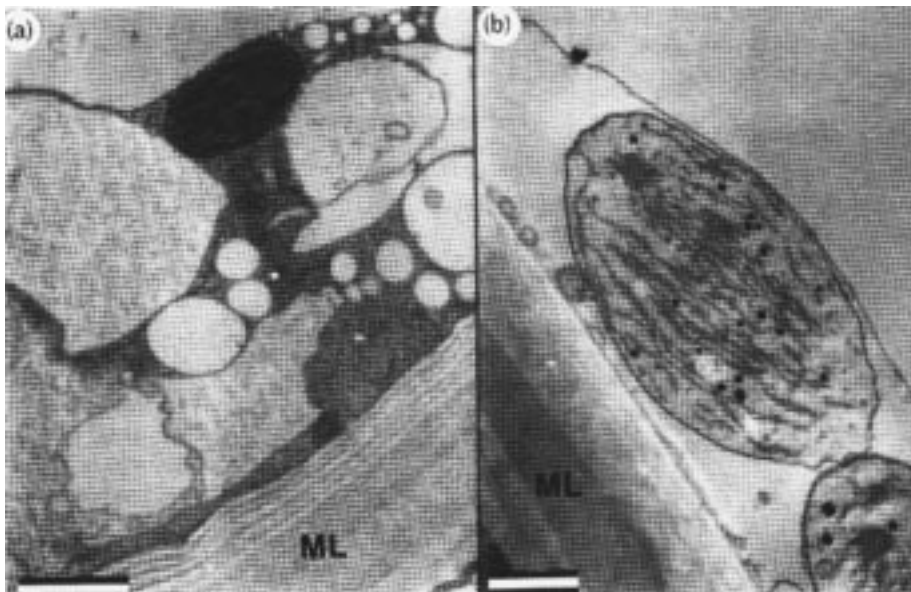
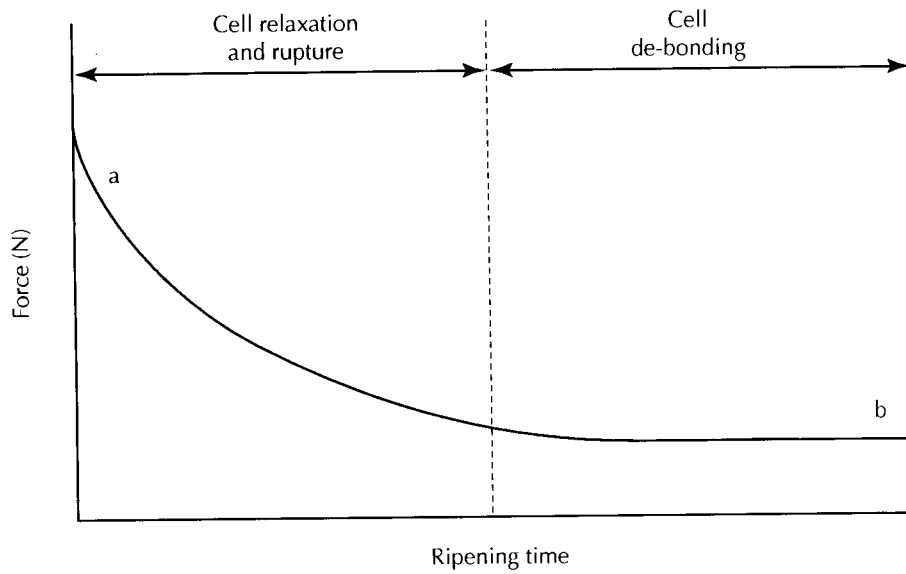

**FIGURE 22.** Transition in failure mode in tomatoes during ripening from mature green to red ripe stages. (From Jackman, R. L. and Stanley, D. W., *Trends Food Sci. Technol.*, 6, 1995.)

overall softening of nonchilled and prechilled tissue but did not change during chilling of tomato fruit.

The largest amount of change occurred in the slow-rate viscoelastic (corresponding to breakdown of pectic materials) and steady-state viscous (related to exosmosis and wall fluidity) properties, and the rate of these alterations was faster

in fruit that had been chilled previously. Jackman and Stanley concluded that loss of turgor, breakdown of polyuronides and an overall increase in cell wall fluidity each contributed 25 to 30% to tomato tissue softening, and the decline in molecular weight size distribution of hemicelluloses was thought to add another 10 to 15%. These results corroborated conclusions reached in an

earlier study by the same authors, using puncture and dynamic oscillation tests (Jackman and Stanley, 1992).

Table 13 summarizes the conclusions reached concerning mechanisms of tomato softening. This study is pivotal in that it correlates an instrumental measurement of textural properties with physicochemical changes occurring during tomato softening. In addition, it illustrates the significant roles that turgor and ripening or processing induced changes in pectin and hemicellulose polymer composition play in maintenance of textural properties.

Mealiness is an undesirable physiological condition that may occur in chilled tomatoes and leaves the fruit lacking juiciness and flavor, exhibiting a dry, soft texture even though the moisture content is the same as non-chilled fruit of the same age (Jackman and Stanley, 1995). The mechanism involves a chilling-induced increase in cytosol membrane leakage and loss of ions or water, which may then bind to deesterified pectin regions or be physically entrapped in the wall matrix. After transfer to non-chilling temperature, polygalacturonase may hydrolyze glycosidic bonds and cells de-bond rather than rupturing. The resultant texture is perceived as mealy because cells are no longer turgid and do not release the internal fluids normally associated with the perception of juiciness. The de-bonding could be related to the findings of van Marle et al. (van Marle et al., 1997) in a comparison of raw and cooked potato varieties. After cooking, both mealy and nonmealy potato varieties lost more unbranched than branched pectin through solubilization to the cooking media. Nevertheless, prolonged cooking (15 min) led to solubilization of more branched, more methylated, and more acetylated pectic polysaccharides in the mealy cv. than in the nonmealy. Marangoni et al. (Marangoni et al., 1995) found that chilling-associated softening correlated ( $p < 0.05$ ) with higher initial extracted pectin methylsterase activity.

## 2. Water and Nutrients

Tomato fruit size is dramatically influenced by water and water stress will result in a shorter

fruit growth period (Salter, 1958). Fruit size, sugar concentration, and acidity have also been shown to increase in glass house studies when plants are fed a nutrient solution with high electrical conductivity (e.g., salt concentration). Under these conditions, dry matter accumulation rather than water was affected and both sugar concentration and acidity were increased. Water absorption results in individual cell expansion, which causes internal turgor pressure to increase. In immature cells, turgor pressure goes up in relation to both water uptake and the strength of cell walls, which counteract and balance the internal pressure buildup. On a larger scale, cell size increases are responsible for fruit expansion and may lead to undesirable cracking of the skin, especially in cases of water stress.

Turgor pressure generally declines as cell wall integrity progressively weakens, primarily at the red ripe and overmature stages in tomatoes. Turgor pressure has a significant effect on tomato cell wall stress, strain, and elasticity. Jackman et al. (Jackman et al., 1992) found the osmotic potential and turgor pressure of fresh market tomato pericarp tissue to be  $-0.56 \pm 0.08$  MPa and 0.20 MPa, respectively. If turgor pressure was increased above normal levels, cell wall extensibility and elasticity became limiting and cell wall stiffness increased. Additional deformation or force applied to such prestressed tissue resulted in failure due to cell rupture, much as in the case of mature green tissues. Decreasing turgor pressure to less than that of normal tissue, however, led to an increase in viscoelasticity and tissue failure resulted from cell de-bonding, similar to that seen in red ripe tissues. The authors concluded that, although the effects of turgor pressure on textural properties were significant, they could not be held accountable for all ripening-related softening changes in tomatoes. In a later study they concluded that turgor-related changes were responsible for 25 to 30% of tomato softening (Jackman and Stanley, 1995).

The three most important nutrients to tomato development and therefore textural integrity are nitrogen, phosphorous, and potassium. Nitrogen may influence both fruit quality and harvest maturity. Some reports indicate that high rates of nitrogen application may result in lower soluble

solids and more blotchy ripening, more yellow eye and poorer machinability (Zobel, 1966 [printed Dec. 1976]). Phosphorous affects fruit quality by stimulating root growth, promoting a sturdy stem and healthy foliage. Potassium is important to tomato fruit acidity, color, and shape (Atherton and Rudich, 1986). Potassium represents 85% of the total cation composition of tomatoes, and at high fruit levels acidity increases and color and shape improve. At low potassium levels, the growth period of the tomato fruit is shortened and fruit will be both smaller and less dense.

Although addition of calcium salts to peeled fruit is known to improve firmness (see discussion below), most studies of the application of calcium fertilizer during production have not determined an improvement in textural properties. Even when applied in excessive amounts, Sayre et al. (Sayre et al., 1940) found no definite effect on the firmness of the harvested and canned fruit. In addition, calcium concentration in the fruit harvested from fields with calcium application was the same as that normally present in tomatoes.

## E. Ripening Associated Softening

The textural characteristics of a particular plant tissue are dependent on the cell turgor; cell anatomy (shape, size); proportion of intercellular spaces; the chemical composition of the cell wall and middle lamella, as well as the spacial arrangement of all the polymers constituent of the whole wall structure. Fruit texture is affected by many factors, such as fruit variety; ripening stage at harvest; agronomic practices; and postharvest handling conditions (Bourne, 1980). For whole tomato fruit, texture depends not only on flesh firmness, but it is also influenced by skin toughness and the ratio of pericarp/ocular material, which is dependent on cultivar type (Grierson and Kader, 1986). Shackel et al. (1991) suggested that some aspects of tomato softening are the result of turgor loss as well as (instead of) changes in the wall integrity. Fruit softening can be a consequence of loss of turgor (such as occurs in dehydration), breakdown of starch (as happens during ripening of the banana fruit), or degradation of

polymer constituents of the cell wall (Tucker, 1993).

The plant cell wall is a very complex structure, and to date is not completely understood. A good review of its composition and a recent model of the cell wall was presented by Carpita and Gibeaut (1993). It is suggested that the cell wall is constituted of three interacting domains. One is the cellulose-xyloglucan (hemicellulose) framework, which is embedded in a second domain of pectic polysaccharides. The structural proteins constitute the third domain (Carpita and Gibeaut, 1993). The approximate proportion of these major polymers in the cell wall of the tomato fruit is: 30% of cellulose, 30% of hemicellulose; 35% of pectic polysaccharides, and glycoproteins and phenolic compounds make up the balance of the wall (Jackman and Stanley, 1995).

Generally, textural modifications observed in intact fruits and vegetables are attributed to metabolism of the cell wall and middle lamella polymers. In the ripening associated softening of tomato fruit, changes in the composition and solubility of cell wall polysaccharides appear to play a major role (Seymour et al., 1987). The major widely reported changes in wall structure of tomato are an increase in soluble polyuronides and a loss of galactose and arabinose residues (Gross, 1984; Gross and Wallner, 1979; Wallner and Bloom, 1977). Carrington and Pressey (1996) suggested that galactosidase II activity correlates with the net loss of galactosyl residues. During ripening of tomato fruit soluble polyuronides are released from the pectic fraction of the cell wall. Huber (1983a) reported a marked increase of low-molecular-weight polyuronides; their weight average decreases from ca. 160,000 to 96,000 (Seymour and Harding, 1987). The loss of pectin integrity during tomato ripening has been implicated as the predominant component of softening.

Endo-polygalacturonase (endo-PG) hydrolyses the  $\alpha$ -(1-4) link between two adjacent galacturonic acid residues within a polygalacturonic acid. Endo-PG is absent in green tomato fruit; it appears at the onset of ripening and its activity increases dramatically during ripening. Exo-polygalacturonase activity has been detected in green tomatoes, however, it comprises only a small frac-

tion of the total polygalacturonase activity in ripening and it is not likely to play a significant role in softening (Giovannoni, 1992).

As endo-polygalacturonase (PG) is more active in degrading nonesterified than methyl-esterified pectin, this suggests the involvement of another enzyme in the softening process: pectinesterase. Pectinesterase (PE) carries out demethoxylation at the C6 position of galacturonate methyl esters of the pectin molecule. Through the action of PE, sites may be generated for subsequent PG attack, in a synergistic mode of action. *In vitro* studies carried out by Pressey and Avants (1982) showed that the presence of PE enhances the ability of PG to solubilize polyuronide. However, the authors reported that the degree of esterification is a critical factor in the solubilization of the cell wall, and that esterification slightly lower than 47% seems to be optimum. Evaluation of total PE activity during the ripening of tomato fruit has been reported to remain constant (Sawamura et al., 1978), to increase (Tucker et al., 1982), or to decrease (Pressey and Avants, 1972). Tucker (1993) suggested that these discrepancies in total PE activity can be related to the use of different tomato cultivars; moreover, total PE activity does not reflect possible changes of individual isoforms of the enzyme. Both PG and PE occur in multiple forms in tomato fruit, such as isozymes PG1, PG2A, and PG2B (Ali and Brady, 1982), and PE1 and PE2 (Pressey and Avants, 1972; Tucker et al., 1982).

According to Seymour et al. (1987; Seymour et al., 1987), it is clear that the extent to which solubilization and depolymerization of pectins occur *in vivo* is not the same as *in vitro*. It is also suggested that the main restriction on polyuronide solubilization is the extent of PE action *in vivo*. Despite the correlation of increased PG activity with degradation of polyuronides, other mechanisms must be involved in softening, as some softening of tomato fruit occurs early in ripening prior to detectable PG activity (Hall, 1987).

Recently, with the use of antisense RNA technology, transgenic plants expressing markedly reduced levels (less than 1% of normal) of polygalacturonase failed to result in the expected reduction of fruit softening (Sheehy et al., 1988). Transformed and normal tomatoes softened simi-

larly. Consequently, it is now believed that PG is either unnecessary or insufficient to mediate tomato fruit softening. It has been suggested that PG may be primarily involved with "over-softening" observed later in tomato ripening (Gross, 1990). In addition, transgenic tomato fruits with reduced levels (less than 10% of the control) of PE have been produced (Tieman et al., 1992). Juice prepared from those fruits contain pectins of much higher molecular weight than pectins isolated from juice of control fruits (Thakur et al., 1996). Also, the degree of esterification (DE) was affected; juice prepared by cold break showed a DE of 14% for the control and DE of 51% for the transgenic fruit. Transgenic fruits showed also a decrease in EDTA-soluble pectins and an increase in soluble solids (Tieman et al., 1992). Moreover, transgenic tomato ripening mutant *rin* expressing a PG gene showed pectin solubilization and hydrolysis, but not fruit softening (Giovannoni et al., 1989).

Cell wall hydrolases other than pectinases (Hobson, 1968; Huber, 1985; Wallner and Walker, 1975) have been examined and their possible role in the softening process investigated. Pressey (1989) described an endo- $\beta$ -mannanase extracted from ripe tomato fruit that hydrolyses  $\beta$ -mannans, which role remains unknown.

Huber (1983b) also reported an increase of low-molecular-weight hemicelluloses after ripening of tomato fruit, while usually cellulose shows no sign of depolymerization. It has been suggested that hemicellulose fractions may form bridges between adjacent cellulose fibrils (Hayashi, 1989). If this is true, a possible cause of fruit softening would be hydrolysis of such bridges.

Maclachlan and Brady (1992) provided evidence for the existence of multiple forms of 1,4- $\beta$ -glucanases in ripening tomato fruit. These enzymes can also be considered as candidates for contributing to softening because their activities increase when softening occurs more rapidly. At least three enzymes with activity on carboxymethylcellulose, CMCases, were detected in extracts of tomato fruit. The CMCases are more concentrated in the locules (Figure 9) of fully ripe fruit than in the pericarp. In addition, two xyloglucanases, XGases, were detected. A latent

oligosaccharide activatable XGase was most concentrated in pink (breaker) pericarp tissue and an endogenous XGase in green pericarp.

Kim et al. (1991) reported that during tomato ripening there is a decrease in cell wall galactosyl residues that they supposed is most likely due to an increased rate of galactosyl solubilization from the cell wall. An exo-1(4)-(-D-galactose from tomato fruit cell wall has been isolated [Pressey, 1983]) and shown to be highly active against its native substrates, and its activity increases 4-fold between the mature green and ripe stages (Carey et al., 1995).

The dogma had been that textural changes occur as polygalacturonase hydrolyses cell wall pectins (Gross, 1990), because of the evident increase in the activity of the enzyme endo-polygalacturonase simultaneously with the increase in soluble polyuronides (Hobson, 1965). This explanation was challenged by the results obtained from the transgenic plants expressing reduced levels of PG and PE. It has yet to be determined how ripening associated softening is controlled.

## F. Effects of Genetic Manipulation

Over the last 10 to 15 years a great deal of work has been dedicated to the use of transgenic tomatoes for more precise definition of the role(s) of certain enzymes in the tomato softening process. Transformation of antisense gene constructs for both polygalacturonase (PG) and pectinesterase (PE) has advantages over the use of ripening mutants, which may exert pleiotropic effects on overall ripening behavior (Kramer et al., 1992). To date, significant improvements in textural properties do appear to have resulted from these genetic manipulations, while differences in general appearance, color, and flavor are not obvious. In the following discussion transformations involving antisense PG and PME constructs are reviewed.

### 1. Polygalacturonase

Kramer et al. (Kramer et al., 1992) of Calgene, Inc., transformed fresh market and processing tomato genotypes with an antisense PG construct

and lines were produced with fruit that had PG levels reduced by more than 99%. Analysis of field grown material demonstrated a significant improvement in firmness of the raw fruit, as measured by flat plate compression, and a decrease in softening during storage of fresh market fruit relative to nontransgenic controls. However, it was also noted that fruit lacking 99% of normal PG activity still soften over time, although more slowly than nontransgenic controls.

Transformed and control lines were processed and evaporated to 10.8° Brix paste at 85°C and then evaluated for a number of typical attributes. Although Ostwald viscometer measurements indicated a significant increase in the serum viscosity of processed juice and paste, it is of interest to note that no other processing characteristic was significantly affected by transformation. The authors suggest that the increase in serum viscosity may be due to almost complete elimination of PG-catalyzed pectin breakdown. However, this study was one of the first to indicate that genetic manipulation of one single enzyme, polygalacturonase, may not be sufficient for elimination of softening in fresh or processed tomatoes.

Another group with Zeneca Plant Science also modified a fresh market tomato cultivar by the expression of antisense RNA to polygalacturonase and obtained plants with <1% of normal PG activity (Schuch et al., 1991). No significant differences were found in samples collected at the breaker stage and processed by either cold or hot break. After color development, however, the cold break samples showed decreased of 45 to 48% in Bostwick values in the transformed lines. While these investigators reported that serum viscosity and cold break juice consistency were higher in transformed fruit, there was no significant improvement in raw fruit firmness. In addition, the authors found no significant difference in hot break consistency or any other processing characteristics.

Two points should be made regarding the texture evaluation procedures used in this study. The method of firmness evaluation utilized involved axial compression of the fruit with 9.8N force for 3 s. It was noted earlier that axial measurements do not correlate well with sensory finger feel, and the structural integrity of the fruit

may constrict deformation except in the case of soft fruit, therefore radial measurements were recommended. Secondly, Bostwick measurements were made on 4°Brix juice, presumably in the standard stainless steel trough that is only designed for paste evaluation. Use of this apparatus for juice samples is inappropriate; therefore, investigators at the University of California designed a longer trough specifically for juices a number of years ago.

## **2. Pectin Methyltransferase**

In a later publication, Schuch, 1994 reported that transformed tomatoes with 10% pectinesterase (PE) activity had also been investigated by the Zeneca group. The major difference obtainable in low PE tomatoes was a significant increase in serum viscosity, which the author attributed to a greater degree of methylation in soluble pectins. Although an improvement in Bostwick consistency was also reported, no data were given for either serum viscosity or Bostwick measurements, therefore, it is difficult to assess the data.

It is interesting to note that in both the Calgene and Zeneca investigations, both transformed PG and PE lines appear to affect serum viscosity to a greater degree than consistency. Luh and Daoud (1971) found similar effects on viscosity, and to a lesser extent on consistency, as a result of thermal processing. These observations point out the complexity associated with tomato product consistency and the inadequacy of the assumption that an enzyme may be individually responsible for softening. In addition, the work on genetic manipulation may further corroborate the model for tomato softening proposed by Jackman and Stanley (1995), which suggest that changes in pectin, hemicellulose, and wall fluidity are the largest contributors.

In a recent study (Thakur et al., 1996), juice made from transgenic tomatoes with less than 10% of wild-type Rutgers fruit pectin methyltransferase (PME) activity was significantly better in quality. Tomatoes were processed under cold break, hot break, and microwave heating procedures had percentage increases in juice quality ranging between 5.1 to 5.3 for total solids, 3.8 to 6.1 for soluble solids, 70 to 80 for efflux viscosity, 180 to

220 for serum viscosity, and about 50 for precipitate weight ratio (Table 18). In addition, ketchup prepared from transgenic fruit juice had a lower Bostwick value, reduced serum separation, and higher serum viscosity when compared with the wild-type product.

The authors were unable to explain the exact mechanism of solids level increase in transgenic juice, however it was noted that low levels of PME in the raw fruit led to a 20 to 40% increase in the degree of pectin methoxylation (Thakur et al., 1996). In addition, raw fruit had higher molecular weight pectins, both factors which other authors have found to result in greater consistency (Kramer et al., 1992; Schuch et al., 1991; Kertesz and Loconti, 1944). It may be that the highly esterified pectins did not break down as easily or adhere to the cell wall, or that the increased degree of methylation was sufficient for PG inhibition.

## **G. Thermal Processing Associated Softening**

In raw produce physiological processes maintain cell turgor pressure, which imparts textural characteristics, such as crispness among others, to fruit and vegetables. As a consequence of thermal processing the hydrostatic pressure responsible for maintaining turgor is absent in processed plant tissues, and usually they are softer than the original raw produce (Bourne, 1989). The chemical changes affecting texture that take place during thermal processing affect the constituents of the cell wall and middle lamella, mainly the pectic polysaccharides.

The textural changes that tomatoes can undergo during processing can be enzymatic and/or chemical. The vast literature on the enzymes that may be involved in ripening associated softening gives an important background information to study the textural changes that occur during the processing of tomato.

Fishman et al. (Fishman et al., 1989; Fishman et al., 1986) suggested that tomato cell wall pectins behave as if they are an aggregated mosaic, held together, at least partially, by noncovalent interactions. This raises the possibility of pectin

**TABLE 18**  
**Quality Characteristics of Tomato Juice from Wild Type and Transgenic Fruit**

Variable	Processing condition <sup>b</sup>	Genotype <sup>a</sup>		
		Rutgers	3781 <sup>^</sup> Azygous	3781 <sup>^</sup> Homozygous
Total solids	Cold	6.83 ± 0.09	6.84 ± 0.03	7.18 ± 0.03 <sup>d</sup>
(% Fr. wt)	Hot	7.36 ± 0/13	7.07 ± 0.08	7.74 ± 0.05 <sup>c</sup>
	MW	6.91 ± 0.03	6.60 ± 0.14 <sup>c</sup>	7.28 ± 0.04 <sup>d</sup>
Soluble solids	Cold	6.18 ± 0.10	6.09 ± 0.08	6.56 ± 0.04 <sup>d</sup>
(% Fr. wt.)	Hot	6.63 ± 0.15	6.60 ± 0.5	6.96 ± 0.06 <sup>c</sup>
	MW	6.33 ± 0.04	6.15 ± 0.06 <sup>c</sup>	6.57 ± 0.04 <sup>e</sup>
Precipitate	Cold	9.25 ± 0.13	9.51 ± 0.33	13.56 ± 0.18 <sup>e</sup>
Weight ratio	Hot	10.67 ± 0.13	11.04 ± 0.21	15.51 ± 0.13 <sup>e</sup>
	MW	11.22 ± 0.22	9.73 ± 0.07 <sup>e</sup>	16.66 ± 0.26 <sup>e</sup>
Serum	Cold	73.33 ± 0.23	73.75 ± 0.53	219.66 ± 10.21 <sup>e</sup>
Viscosity	Hot	93.33 ± 2.42	103.91 ± 2.07 <sup>c</sup>	262.91 ± 10.75 <sup>e</sup>
(Sec)	MW	77.33 ± 0.59	74.75 ± 0.16 <sup>c</sup>	258.58 ± 14.90 <sup>e</sup>
Efflux	Cold	28.00 ± 1.04	28.11 ± 1.12	43.17 ± 4.50 <sup>e</sup>
Viscosity	Hot	30.67 ± 1.04	31.04 ± 1.21	58.16 ± 2.30 <sup>e</sup>
(Sec)	MW	29.11 ± 2.11	29.16 ± 1.07	50.28 ± 1.72 <sup>e</sup>
pH	Cold	4.25 ± 0.02	4.28 ± 0.01	4.35 ± 0.023 <sup>e</sup>
	Hot	4.28 ± 0.01	4.27 ± 0.01	4.33 ± 0.01 <sup>d</sup>
	MW	4.27 ± 0.02	4.21 ± 0.01 <sup>c</sup>	4.35 ± 0.02 <sup>d</sup>
Acidity	Cold	0.49 ± 0.01	0.53 ± 0.03 <sup>e</sup>	0.50 ± 0.01
(% citric acid)	Hot	0.53 ± 0.01	0.55 ± 0.01 <sup>c</sup>	0.53 ± 0.01
	MW	0.51 ± 0.01	0.57 ± 0.01 <sup>e</sup>	0.50 ± 0.01

<sup>a</sup> 3781<sup>^</sup> Azogous and 3781<sup>^</sup> Homozygous represent the segregated progenies of transformant 3781<sup>^</sup> containing 0 and 2 copies of the introduced PME antisense RNA gene, respectively.

<sup>b</sup> Cold, hot and MW represent cold-break, hot-break and break after microwaving tomatoes, respectively.

<sup>c</sup> Significantly different from Rutgers ( $P < 0.05$ ).

<sup>d</sup> Significantly different from Rutgers ( $P < 0.01$ ).

<sup>e</sup> Significantly different from Rutgers ( $P < 0.001$ ).

From Thakur et al., *J. Food Sci.*, 61, 1, 1996.

depolymerization through a nonenzymatic mechanism of deaggregation.

Heating brings major change in the firmness of vegetables, for example, the softening accompanied by solubilization and depolymerization of pectin, which can be excessive in the processing of low-acid vegetables. After the loss of turgor brought by blanching, the remaining mechanical properties of the tissue depend on the structure, arrangement, and chemical composition of the cell wall (Van Buren, 1979). Less desirable textural properties are frequently associated with canned fruits and vegetables due to the length of

heat treatment required to ensure safety of the product. At low pH values pectin depolymerization occurs through an acid-catalyzed hydrolysis mechanism. Deesterification can also occur by an acid-catalyzed mechanism. Both below and above pH 4, depolymerization and deesterification occur simultaneously, the rate of deesterification being higher than the rate of depolymerization (BeMiller, 1986). For many vegetables, pH values are above 5; under these conditions pectin depolymerization occurs through a  $\beta$ -elimination type of reaction, catalyzed by hydroxyl ions, and inhibited by demethoxylation of pectins.



Although softening is usually associated with processing, enzyme-catalyzed changes of pectic polysaccharides have also been related to a firming effect in precooked fruits and vegetables. This firming effect by precooking or blanching involves activation of PME, deesterification of pectin, and further formation of crosslinkages of pectic polysaccharides through bridges with Ca or Mg. Enhanced retention of fruit firmness has been reported after removal from storage of apples that had been heated (38°C/4 d) before storage. Although enzymatic activity increased similarly in both unheated and heated stored apples, the treated fruit softened much less than the unheated. Water- and CDTA-soluble pectin had a decrease in their DE in both heated and unheated samples (Klein et al., 1995). Frozen then thawed carrots exhibited decrease in firmness, but carrots that were preheated (60°C/2 h) then cooked retained firmer texture than raw or cooked carrots (Fuchigami et al., 1995). Mohamed and Hussein (1994) reported that a low temperature long-time blanching (70°C/20 m) associated with a calcium treatment significantly improved the texture of rehydrated dried carrots compared with carrots submitted to a HTST blanching (100°C/3 m). Canning green beans and carrots after extended blanching and addition of calcium and/or acid resulted in firmer products. Results showed evidence of intact middle lamella in firmer beans, while cell separation was observed in softer samples (Stanley et al., 1995). Textural changes of snap bean pods during cooking have been attributed to a deesterification of pectin molecules by PME during precooking steps, and further formation of Ca or Mg pectates, resulting in tissue firmness (Chang et al., 1996). However, Stolle-Smiths and collaborators (1995) suggested that the overall decrease of degree of methylation after sterilization of green beans is more likely caused by a  $\beta$ -elimination mechanism. Also, in model studies it was shown that the solubilization of pectin of potato cell walls boiled at pH 6.1 is by a  $\beta$ -elimination degradation (Keijbets et al., 1976). Alkali soak prior to cooking is effective in retarding tissue softening due to a decreased degree of esterification of the pectin, and consequently a reduced susceptibility of the deesterified pectin to depolymerization through a  $\beta$ -elimination type of

reaction (Sajjaanantakul et al., 1989; Van Buren and Pitifer, 1992).

In a comparison of the firmness of snap beans that had been canned with salt (salt cook) or were added of salt after canning (salt soak), Van Buren (1986) found that the use of NaCl in the canning media contributed to softer cooked beans than when water was the canning media. The ability of monovalent salts to increase the softness apart from heating may be related to  $\text{Ca}^{+2}$  displacement. Decrease of canned bean firmness caused by the presence of salts can be a consequence of both displacement of  $\text{Ca}^{+2}$ , which takes place apart from cooking, and pectin solubilization, which requires cooking.

## H. Effects of Added Calcium Salts

Thermal treatment results in a loss of textural integrity; therefore, many processed tomato products in which integrity is desirable (i.e., whole peeled tomatoes, sliced, wedged, diced, and crushed tomatoes) are improved by the addition of small amounts of calcium salts, which act as firming agents. Because calcium is a divalent cation, it is able to bind free carboxyl groups on adjacent pectin polymers and bridge them, thereby creating a more stable three-dimensional network and imparting additional firmness to the tissue. The addition of calcium salts to tomatoes causes the formation of a calcium pectate gel, which supports the tissues and minimizes tomato softening.

The FDA has approved use of the following salts as firming agents: purified calcium chloride, calcium sulfate, calcium citrate, mono-calcium phosphate, or any two or more of these in concentrations, not to exceed 0.045% except for diced, wedged, or sliced tomatoes and not to exceed 0.08% calcium by weight in the finished canned tomatoes (21 CFR 155.190, 1994). Italian standards for addition of calcium is 100 mg/kg (or 1000 ppm), which is higher than the 800 mg/kg allowed in the U.S. In diced, wedged, or sliced tomato products the FDA Standard of Identity reads that the amount of calcium added may not be more than 0.1% of the weight of the finished food. The addition of a firming agent must be

declared on the label. Calcium chloride is the most commonly added salt, and typically it is used in the form of special tablets, or as a solution of sodium chloride-calcium chloride dissolved in tomato juice.

Kertesz et al. (Kertesz et al., 1940) carried out many of the pioneering studies of the effects of calcium salt addition on the firmness of canned whole peeled tomatoes. In an exceptionally well-conducted series of experiments, these investigators compared the relative merits of three methods of calcium chloride ( $\text{CaCl}_2$ ) treatment: calcium chloride dips prior to canning, calcium chloride dissolved in tomato juice and added to cans, or incorporation into salt tablets. Because these early experiments formed the basis for current practices of calcification, they are reviewed in some detail.

In initial studies, peeled fruit were dipped for 1, 5, and 10 min into solutions of 1, 5, and 10%  $\text{CaCl}_2$ . Although drained weight increased substantially, no consistent increase could be noted from treatments longer than a 1 min dip in 5%  $\text{CaCl}_2$  (Table 19). Indeed, bitterness and a leathery texture was noted when tomatoes were dipped 5 min in 5%  $\text{CaCl}_2$ , and in 10%  $\text{CaCl}_2$  solutions tomatoes were considered tough and had white precipitate on their surfaces. The authors claimed that the bitter flavor of  $\text{CaCl}_2$  was not a significant factor, because textural quality (e.g., leatheriness) usually developed in samples treated with excessive amounts of  $\text{CaCl}_2$  at lower concentrations than those at which the bitter flavor became apparent.

However, in a second set of dipping experiments,  $\text{CaCl}_2$  concentrations were decreased to 1, 2.5 and 5%. The best results were obtained with 1% solution dips for 5, 10, or 15 min or 2.5% solutions for 2.5 min. It was noted that rates of calcium uptake (Figure 23) in any concentration dip solution did not increase significantly after the first 2 to 3 min of dipping. Based on these results, the authors suggested a treatment for 2 to 3 min in a 2%  $\text{CaCl}_2$  solution.

Although the amount of calcium uptake increased with the warmer dip solutions, this practice was not recommended because the solution temperature would have to be carefully controlled and tomatoes were observed to soften more in warmer solutions. In a later study where the po-

tential of peeling whole fruit in boiling  $\text{CaCl}_2$  solutions was evaluated, it was found that although drained weight increased with dipping time, calcium uptake and firmness increases were not uniform between dipping time intervals (Stephens et al., 1973). Peeling in hot calcium solutions, therefore, was eventually not recommended due to the difficulty in controlling the amount of calcium uptake and the need for constant supervision to prevent excessive tomato softening.

Determination of calcium content in the dipping experiments conducted by Kertesz et al. (Kertesz et al., 1940) indicated that in order to cause a desirable increase in firmness the calcium content must be increased by approximately 100 to 300 ppm. These investigators evaluated samples produced all over the U.S. and found the following natural calcium contents of drained whole tomatoes: California, 57 ppm; Delaware, 92 ppm; Indiana, 51 ppm; Maryland, 63 ppm; New York, 61 ppm; and Pennsylvania, 73 ppm. Although the natural variation was considerable, none of the samples tested reached 100 ppm; therefore, supplementation was deemed desirable.

Experiments conducted by Kertesz et al. on dissolving calcium chloride in tomato juice involved use of range from 6 to 24.8 grains of  $\text{CaCl}_2$ , which is equivalent to 0.39 to 1.56 g  $\text{CaCl}_2$  or 0.141 to 0.562 g Ca, in each can. The best results, in terms of drained weight and percentage of tomatoes remaining whole, were obtained with 12 to 18 grains (0.282 to 0.421g Ca/can). This method of application, however, suffers from the requirement for a fairly pure salt, and it has been found (Kertesz et al., 1940) that only about one-third to one-half of the added calcium is utilized with the rest remaining in the juice. In the case of dipping applications, because the  $\text{CaCl}_2$  does not actually enter the can it is possible to use commercial grades of calcium chloride, which are much cheaper.

In evaluating the last method of  $\text{CaCl}_2$  application, which utilized salt tablets added directly to the can, the following amounts gave the best results: In the case of firm fruit, 7.5 grains; in the case of soft fruit, 10 grains; and in the case of very soft fruit, 12.5 grains per No. 2 size can (Kertesz et al., 1940). Although this was the easiest means of adding  $\text{CaCl}_2$ , it is quite hygroscopic and tablets containing this compound and table salt deteriorate

**TABLE 19**  
**Results Obtained by Dipping Tomatoes in Calcium Chloride Solution**

No.	Concentration of CaCl <sub>2</sub> per cent	Duration of dip min.	Temperature of dip solution, °F	No. of cans analyzed	Percent-age of tomatoes remaining whole	Flavor	Texture	Sediment	Calcium PPM		Drained weight	
									In drained meat	Increase over control	Percentage of "put in weight"	Percentage of can capacity
Packed in No. 2 1/2 size cans												
1	Control	—	—	6	16	OK	OK	None	56	—	71.7	54.2
2	1	1	120–140°	3	93	OK	OK	None	141	85	84.7	69.6
3	1	5	120–140°	3	100	OK	OK	None	166	110	88.7	66.6
4	1	10	120–140°	3	93	OK	OK	None	149	93	87.2	69.0
5	5	1	120–140°	3	100	OK	OK?	None	392	336	93.6	75.4
6	5	5	120–140°	3	100	OK?	Off	None	588	532	90.7	74.8
7	5	10	120–140°	3	100	Off	Off	None	772	716	93.7	75.5
8	10	1	120–140°	3	100	Off	Off	Much	422	366	89.4	72.0
9	10	5	120–140°	3	100	Off	Off	Much	—	—	91.8	75.9
10	10	10	120–140°	3	100	Off	Off	Much	—	—	94.5	78.5
Packed in No. 2 size cans												
11	Control	—	—	3	30	OK	OK	None	63	—	74.6	58.7
12	1	5	80°	2	100	OK	OK	None	211	148	82.8	70.8
13	1	10	80°	3	100	OK	OK	None	161	98	86.7	68.0
14	1	15	80°	2	100	OK	OK	None	182	119	84.6	69.0
15	2.5	2.5	80°	3	100	OK?	OK?	None	265	202	84.1	67.3
16	2.5	5	80°	2	100	Off	Off	None	223	160	87.2	67.4
17	5	2.5	80°	3	100	Off	Off	None	412	349	90.6	71.2
18	5	5	80°	2	100	Off	Off	None	361	298	92.1	71.0
19	Control	—	—	3	60	OK	OK	None	61	—	81.6	58.6
20	5	5	64–68°	4	100	OK	OK	None	615	554	86.8	69.1
21	5	5	100–115°	3	100	OK	Off	None	819	758	87.4	76.3
22	5	5	120–140°	3	100	OK	Off	None	877	816	88.5	72.2
23	5	5	140–168°	4	100	OK	Off	None	1,026	965	86.0	75.0
Packed in No. 10 size cans												
24	Control	—	—	2	Few	OK	OK	None	60	—	47.3	45.2
25	2.5	5	80°	2	100	OK	OK?	None	502	442	79.8	66.3

From Kertesz et al., *Technical Bulletin No. 252*, New York State Agricultural Experiment Station, April 1940.

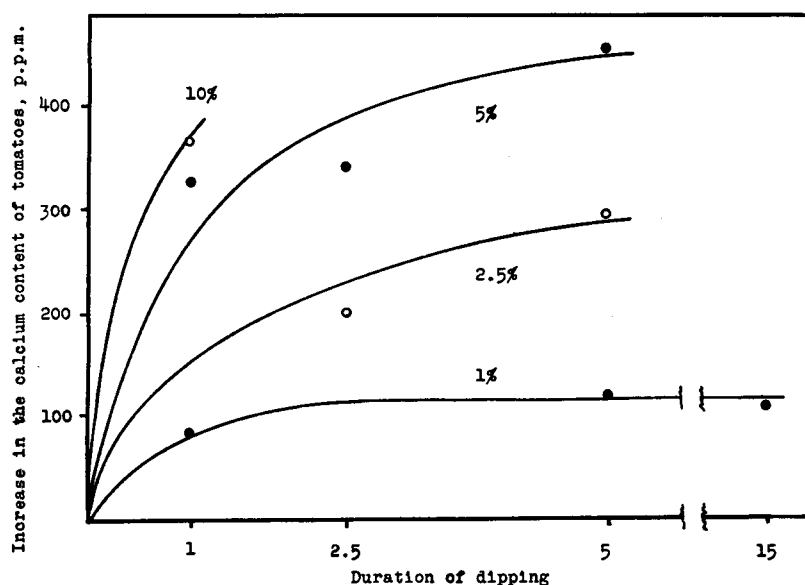

**FIGURE 23.** Calcium taken up by tomatoes dipped in calcium chloride solutions. (From Kertesz, Z. I. et al., *Technical Bulletin*, 252, New York State Agricultural Experiment Station, 4, 1940.)

very quickly in the open air. Tablets containing anhydrous  $\text{CaCl}_2$  and sodium chloride in the appropriate amounts are available today, but it is necessary to package them in moisture-proof containers and to open them just prior to use (Gould, 1992). After an evaluation of effect on textural properties, cost and ease of use, Kertesz et al. recommended the method of  $\text{CaCl}_2$  addition by dipping in solutions of 2% for 2 to 3 min. Later studies with calcification are reviewed below in conjunction with specific processed tomato products. Today it is general practice to add calcium chloride or sodium chloride-calcium chloride tablets when filling into individual cans and to dissolve tablets into tomato juice in which tomato products are dipped when packing in drums.

## VII. TEXTURAL PROPERTIES OF PROCESSED TOMATO PRODUCTS

### A. Whole Peeled Tomatoes

#### 1. Grades and Standards

Textural integrity is a vital determinant of the quality of canned whole peeled tomatoes. Firm-

ness will significantly affect ease of peeling, wholeness, and drained weight of the final product. Specifications for whole peeled canned tomatoes are covered by USDA Standards for Grades and by FDA Standards of Identity, Quality, and Fill of Container. The grade of canned tomatoes is based on drained weight, character, color, wholeness, flavor and odor, and defects. According to U.S. Standards for Grades of Canned Tomatoes, U.S. Grade A or U.S. Fancy canned tomatoes must have a drained weight not less than 66% of the capacity of the container; U.S. Grade B or U.S. Extra Standard must have a drained weight of not less than 58% of the capacity of the container, and U.S. Standard or Grade C canned tomatoes must have a drained weight of not less than 50% of the capacity of the container (Gould, 1992). Drained weight is significantly affected by tomato variety and maturity, initial raw textural quality, process conditions, and fill weight. Average minimum drained weight requirements for meeting U.S. grades for all styles of canned and stewed tomatoes are specified.

Character requirements are specified in a similar way for A, B, and C grades of whole peeled, stewed, halved, wedged, diced, and sliced tomatoes. For all products, Grade A is required to have

“good” character; Grade B “reasonably good character”, and Grade C “fairly good character”. Character is defined as “degree of firmness normally found when tomatoes have been processed using good manufacturing practices as defined in 21 CFR part 110” (Gould, 1992). Cooked tomato products which are excessively soft or mushy are considered lacking in character. Excessively soft products are further defined as meaning that “the unit may disintegrate upon handling, has evidence of sloughing or has ragged edges, and has lost ability to hold its shape”. The following are more specific definitions from the U.S. Standards:

1. **Good character:** Products, with the exception of diced tomatoes, in which not more than 15 percent by count are excessively soft or mushy. In diced tomatoes, not more than 15 percent by weight are excessively soft or mushy.
2. **Reasonably good character:** Products, with the exception of diced tomatoes, in which not more than 25% by count are excessively soft or mushy. In diced tomatoes, not more than 25% by weight are excessively soft or mushy.
3. **Fairly good character:** Products, with the exception of diced tomatoes, in which more than 25% by count are excessively soft or mushy. In diced tomatoes, more than 25% by weight are excessively soft or mushy.

## 2. Peeling Operation

One of the first unit operations involved in whole peeled tomato production is peeling. The objective of the peeling operation is to split or crack the tomato peel to a sufficient degree that the peel will be subsequently removed when the tomato passes over mechanical peel eliminators, typically a rubber disc roller followed by a pinch roller bed. In the early 1900s, tomatoes were blanched in ambient pressure steam or in boiling water, immersed or sprayed with cold water to crack the skin, and then the peel was removed by hand (Corey, 1986). Beginning in the 1960s, the use of hot lye (sodium hydroxide or caustic) solutions and peeling aids allowed for more effi-

cient peel removal. In the 1970s a move began away from the use of lye due to waste disposal problems, lower product recovery, and the complexity of recovering peel and pulp tissue. During this period a number of studies were carried out to investigate the use of hot calcium chloride solutions (Stephens et al., 1973), application of freeze-heating (Leonard and Winters, 1974; Thomas et al., 1978), high-pressure or superheated steam and flame or infrared treatments on peeling efficiency (Weaver et al., 1980). In recent years, the application of high-pressure steam (7 to 10 bar) for short dwell times (5 to 15 s) in combination with mechanical peel eliminators has replaced lye peeling operations in most tomato processing operations (Corey, 1986).

Efficiency of peel removal by high-pressure steam has been shown to depend on steam pressure, dwell time, variety, and presence disorders such as yellow shoulder disorder (YSD) (Corey, 1986). Subjecting the tomato to too much heat may result in softening and/or removal of excessive amounts of tomato pericarp and a reduction in yield. Optimization of the peeling operation to achieve adequate peel loosening without excessive yield loss is a challenge and depends to a large part on tomato variety, maturity, and fruit size. Tomato processors should be aware of the genetic identity of incoming raw fruit and determine the optimum combination of steam pressure and dwell time to maximize product recovery, throughput, and quality.

In a study comparing steam exposure at high (4.34 bar) and low (2.81 bar) pressures, whole tomato recovery decreased with increasing steam pressure and dwell time in two processing tomato varieties. Recovery ranged from 64.8 to 77.8%, and quantity of adhering peel ranged from 385 to 1866 mg/kg fruit for nine varieties steam peeled at 4.4 bar (Corey, 1986). Equations for the prediction of percent recovery and quantity of adhering peel as functions of steam pressure, dwell time, and percent YSD were developed for two processing varieties.

The ease with which tomatoes are peeled may be correlated to their susceptibility to skin cracking, an undesirable characteristic that may occur during fruit growth as a result of water stress. Indeed, some investigators have concluded that

the epidermis is the single most important component of the tomato as related to mechanical strength (Murase and Merva, 1977). Voisey et al. (Voisey et al., 1970) found that the strength of tomato skin and resistance to cracking was not governed by skin thickness, but rather by skin strength and its ability to stretch. These authors compared different cultivars of tomatoes with varying susceptibility to cracking and through microscopy determined that the penetration of the cutinized outer layer into the outer cells of the skin could be correlated to skin strength.

### 3. Thermal Processing Operations

In 1988, Wahem (Wahem, 1988) conducted a study in which raw processing tomatoes were sorted by firmness and the effects on the physical, chemical, and sensory characteristics of canned whole peeled tomato products were evaluated. A commercial vibratory sorter was used to sort fruit, which were then lye peeled and canned. Unfortunately, the study did not utilize any objective method of textural evaluation to verify differences in “soft”, “firm”, and “unsorted” fruit. How-

ever, firm fruit were found to be significantly ( $P < 0.05$ ) higher in drained weight, Agtron E-5 color readings, total acidity, sodium hexametaphosphate-soluble, and sodium hydroxide-soluble pectic substances, and lower in pH, soluble solids, soluble solids/acid ratio, and water-soluble pectin than soft and unsorted fruits (Tables 20 and 21).

Drained weight differences were thought to be due to less cell rupture and leakage of cell contents to cover liquid in the firmer, possibly less mature fruit (Wahem, 1988). The texture of the canned tomatoes, as evaluated by a sensory panel, was negatively correlated ( $-0.936$ ) with total water-soluble pectin and positively correlated with sodium hexametaphosphate-soluble (0.934) and sodium hydroxide-soluble (0.959) pectic substances. In addition, the texture of canned tomatoes was highly correlated (0.922) with the drained weight of the product. Water-soluble and salt-soluble differences in pectic substances were suggested to reflect solubilization of pectic materials with ripening. The fact that color of the soft fruit was significantly more red than that of the firm fruit supports the suggestion that the latter were less mature.

**TABLE 20**  
Effects of Degree of Firmness on Quality Attributes of Canned Whole Peeled Tomatoes

Quality factors	Avg. of individual cultivars			
	Unsorted	Soft	Firm	L.S.D.
% Drained weight	66.70 B	66.25 C	67.65 A	0.11
Color (Agtron E-5)	44.50 B	29.75 C	63.50 A	2.24
pH of fruits	4.28 B	4.32 A	4.25 C	0.01
pH of cover liquids	4.28 B	4.32 A	4.25 C	0.01
% Total acidity of fruits	0.34 B	0.32 C	0.36 A	0.01
% Total acidity of cover liquids	0.34 B	0.32 C	0.36 A	0.01
% Soluble solids of fruits	3.43 B	3.57 A	3.19 C	0.12
% Soluble solids of cover liquids	3.43 B	3.57 A	3.19 C	0.12
Soluble solids/acid ratio	10.21 B	11.33 A	8.98 C	0.42
Mg ascorbic acid	12.07 A	11.90 A	12.20 A	—

Note: For each quality factor, values in the same row followed with the same letter are not significantly different ( $P \leq 0.05$ ).

From Wahem, I. A., *J. Food Quality*, 11, 1988.

**TABLE 21**  
**Effects of Degree of Firmness on Pectic Substances of Canned**  
**Whole Peeled Tomatoes**

Pectic substances	Avg. of individual cultivars			
	Unsorted	Soft	Firm	L.S.D.
% Total pectin	0.27 A	0.27 A	0.27 A	—
% of total pectin				
Water-soluble in cover liquids	23.10 B	26.26 A	16.49 C	2.56
Water-soluble in fruits	33.31 B	35.78 A	30.17 C	1.45
3Na <sub>2</sub> O: 3P <sub>2</sub> O <sub>5</sub> -soluble in fruits	26.34 B	24.18 C	30.53 A	2.14
NaOH-soluble in fruits	17.24 B	13.78 C	22.81 A	1.64

Note: For each pectic fraction, values in the same row followed with the same letter are not significantly different ( $P \leq 0.05$ ).

From Wahem, I. A., *J. Food Quality*, 11, 1988.

## B. Stewed Tomatoes

In the manufacture of canned stewed tomatoes, not as much care as taken in whole peeled processing is required during peeling, as the tomatoes are broken or cut into sections for this product. However, a high standard grade of tomatoes is generally used for this pack and some processors prefer to use extra standard grade. While it is desirable to have the tomatoes in sections or small pieces, maintenance of textural integrity is critical (Lopez, 1996).

## C. Diced, Chopped, and Crushed Tomatoes

### 1. Grades and Standards

In 1991, salsa replaced ketchup as the top-selling condiment in the U.S., opening the floodgates to salsa and salsa-related food manufacturing. Although the demand for diced, chopped, and crushed tomatoes as ingredients in products such as pizza sauce, spaghetti sauce, and salsa has risen astronomically during the last decade, Standards of Identity have yet to be defined by the FDA for these product types. They are typically graded according to the same standards that were developed for canned whole peeled tomatoes; however, some countries do not even regulate these products.

Legislators in both the U.S. and European countries commonly use drained weight measurements as one of the few quality parameters that may stand up to scrutiny in evaluation of the consistency of diced, chopped, or crushed tomatoes. Drained weight requirements for these products are as stipulated for whole peeled tomatoes, except for the case of individual no. 2 1/2 or smaller cans of diced product that do not meet the average drained weight requirements. In a diced product not more than 0.5 ounce may be lower than the minimum average, whereas in other styles not more than 0.7 ounces may be lower.

The selection of the appropriate tomato variety for processing is crucial to producing chopped or dice pieces of the highest textural integrity and the most intense red color. Textural integrity is even more important than with the more comminuted tomato products, and variety plays a significant role. Typical dice sizes produced include the following:  $1 \times 1 \times 1 \text{ in}^3$  ( $25 \times 25 \times 25 \text{ mm}^3$ ),  $1 \times 3/4 \times 3/4 \text{ in}^3$  ( $25 \times 19 \times 19 \text{ mm}^3$ ),  $1/2 \times 3/8 \times 3/8 \text{ in}^3$  ( $13 \times 9.5 \times 9.5 \text{ mm}^3$ ),  $1/2 \times 1/2 \times 1/2 \text{ in}^3$  ( $13 \times 13 \times 13 \text{ mm}^3$ ),  $5/8 \times 5/8 \times 5/8 \text{ in}^3$  ( $16 \times 16 \times 16 \text{ mm}^3$ ), and others. Choice of chopped, crushed, or dice size will depend on the characteristics of the final product to which the dice ingredients are added but will be limited by the need to ensure adequate heat penetration into the dice pieces during thermal processing.

## 2. Definition of Quality

In recent years, a number of excellent publications concerning diced tomato product quality have come out of Italian laboratories (Castaldo et al., 1995; Castaldo et al., 1995; Porretta, 1993; Porretta et al., 1992; Porretta et al., 1995; Porretta et al., 1992; Porretta et al., 1993). The Italians use the term “pulp” to describe crushed, diced, or chopped tomatoes with about 30% tomato juice as packing medium, whereas U.S. standards of identity define pulp differently (see discussion below). Because the Italian pulp products are essentially diced tomatoes with topping juice, their quality and processed conditions are discussed in this section rather than under the formulated products discussion.

In 1992, Poretta et al. (1992; 1993) evaluated the quality of commercially formulated tomato pulp using quantitative descriptive analysis (QDA) techniques. Tomato pulp produced by eight European processors was characterized in terms of the following physical, chemical, and sensorial properties: % drained weight, color, consistency, volatile acidity, color of serum, total acidity, pH, total solids, D- and L-lactic acid, glutamic, monohydrate citric and acetic acid, sodium chloride, glucose and fructose, pectin, and sensory properties (acid taste, natural taste, homogeneity of redness, and viscosity). Unfortunately, the authors did not specifically define the pulp products in terms of processing method, variety or dice size used, or other specifications; therefore, it is difficult to compare products. Nevertheless, Table 22 illustrates the ranges, maximum, minimum, and other statistical values for the eight products evaluated.

From the textural properties point of view, it is interesting to note in particular the range in percent drained weight, pulp and juice Bostwick, total solids, pectic materials, and sensory viscosity score. It would appear that the tomato products analyzed by these authors suffered from a lack of standardization. When the various attributes were compared statistically, the highest correlations existed between the following texture-related attributes (Porretta et al., 1992): sensory viscosity and drained weight ( $r = 0.92$ ), protopectin and pectates ( $r = 0.77$ ), pectic acid and pectates ( $r = 0.69$ ), and sensory viscosity and pectates

( $r = 0.61$ ). Poor correlations were found between drained weight and Bostwick consistency ( $r = -0.37$ ), drained weight and pectic acid ( $r = 0.20$ ), and drained weight and protopectin ( $r = 0.35$ ).

Porretta et al. (1992) compared the profiles of tomato pulps with the highest and lowest quality, as determined by D- and L-lactic acid, total acidity, and volatile acidity contents, because these parameters were thought to be related to possible causes of spoilage, raw material conditions, and color of serum (browning index). Figures 24 and 25 illustrate that the best pulps were also higher in sensory viscosity, Bostwick consistency, and pectic material content, but not necessarily higher in drained weight. The authors did not comment on the ranges of attribute values obtained, but used discriminant analysis (Porretta et al., 1993) to classify commercial samples according to attributes that showed significant differences, for example, drained weight, pulp and juice Bostwick consistency, color (L, a and b values), pH, soluble solids, total solids, serum color, fructose, acetic acid, and glutamic acid.

## 3. Addition of Calcium Salts

The addition of calcium salts results in a significant improvement in the textural properties of diced tomatoes. The effects of calcium salts on tomato products in general was discussed earlier. In work carried out in our laboratory, the effects of dipping 1/2" diced tomatoes in various concentrations of calcium chloride (0, 0.5% and 1.0%) for 3 min were evaluated (Barrett and Garcia, in preparation). Processing variety Halley 3155 tomatoes were steam peeled (250°F for 30 s), diced, dipped, and drained for 1 min, then triplicate 200-g samples were evaluated for maximum force using a shear press cell fitted to an Instron Universal Testing Machine. All force values were expressed as a ratio of raw control firmness, and it is clear from Figure 26 that dipping in 0.5%  $\text{CaCl}_2$  resulted in an approximately 50% increase in firmness. No additional benefit was obtained from increasing the  $\text{CaCl}_2$  concentration from 0.5 to 1.0%.



**TABLE 22**  
**Results of Physical, Chemical, and Sensory Analyses of Tomato Puree**

	Acetic acid, g/kg TS	Glutamic acid, g/kg TS	Diacetyl, mg/kg	AMC, g/kg	Glucose, g/kg TS	HMF, mg/kg	AIS, g/kg	Pectic acids, g/kg TS
Range	2.60	30.37	7.60	0.69	206.70	4.36	396.30	20.00
Minimum	0.40	21.30	0.00	0.01	90.80	0.00	408.89	12.00
Maximum	3.00	51.65	7.60	0.70	297.50	4.36	805.22	32.00
Mean	1.40	33.79	1.81	0.19	141.50	0.79	594.00	20.00
SDa	0.30	8.02	2.34	0.19	44.50	1.60	100.12	6.00
Median	1.10	31.75	0.66	0.11	131.20	0.00	593.10	16.00
F ratio <sup>a</sup>	4.01 <sup>b</sup>	42.70 <sup>b</sup>	11.00 <sup>b</sup>	5.01 <sup>b</sup>	5.44 <sup>b</sup>	2.90 ns	11.1 <sup>b</sup>	19.3 <sup>b</sup>

	Pectates, g/kg TS	Protopectins, g/kg TS	Drained weight, %	Bostwick pulp	Bostwick juice	L	a <sub>L</sub>	b <sub>L</sub>
Range	31.00	5.00	31.80	7.00	8.50	3.41	7.91	1.82
Minimum	7.00	2.00	64.80	0.00	1.00	23.57	23.91	12.76
Maximum	39.00	7.00	96.60	7.00	9.50	26.98	31.82	14.58
Mean	17.00	4.00	79.65	3.77	5.57	25.71	29.70	13.87
SDa	8.00	1.20	9.35	2.20	2.60	0.92	2.05	0.21
Median	16.00	4.00	77.66	4.25	6.50	25.95	30.36	13.97
F ratio <sup>a</sup>	32.20 <sup>b</sup>	5.40 <sup>b</sup>	29.10 <sup>b</sup>	9.70 <sup>b</sup>	13.50 <sup>b</sup>	4.14 <sup>b</sup>	5.25 <sup>b</sup>	3.87 <sup>b</sup>

	a <sub>L</sub> /b <sub>L</sub>	pH	Volatile acidity, g/kg TS	Total acidity, g/kg TS	Sodium chlorided, g/kg TS	Fructose, g/kg TS	Total solids, g/kg	Color of serum
Range	0.52	0.34	56.50	41.70	107.72	189.20	42.40	0.17
Minimum	1.84	4.12	0.90	49.80	6.14	94.50	50.00	0.19
Maximum	2.36	4.46	57.41	91.50	113.87	283.70	92.40	0.36
Mean	2.14	4.30	20.80	67.20	31.80	151.00	71.00	0.22
SDa	0.12	0.30	15.37	9.90	28.17	45.80	11.90	0.04
Median	2.17	4.30	13.21	66.30	22.56	135.60	68.80	0.26
F ratio <sup>a</sup>	5.00 <sup>b</sup>	9.00 <sup>b</sup>	118.00 <sup>b</sup>	32.60 <sup>b</sup>	3174.00 <sup>b</sup>	419.00 <sup>b</sup>	108.00 <sup>b</sup>	5.18 <sup>b</sup>

  

	L-Lactic acid, g/kg	D-lactic acid, g/kg	Soluble solids, g/kg	Citric acid, g/kg TS	Acidity (sensory)	Natural taste (sensory)	Color (sensory)	Viscosity (sensory)
Range	0.53	0.64	41.00	89.65	8.00	8.00	8.00	8.00
Minimum	0.00	0.00	45.00	20.51	1.00	1.00	1.00	1.00
Maximum	0.53	0.64	86.00	110.16	9.00	9.00	9.00	9.00
Mean	0.16	0.11	64.00	55.82	5.20	4.60	6.50	5.15
SDa	0.17	0.17	11.90	16.64	2.25	1.10	3.00	2.34
Median	0.07	0.94	62.30	55.91	5.50	5.40	5.50	5.45
F ratio <sup>a</sup>	14.90 <sup>b</sup>	9.90 <sup>b</sup>	178.00 <sup>b</sup>	230.00 <sup>b</sup>	9.28 <sup>b</sup>	2.61 ns	20.10 <sup>b</sup>	19.18 <sup>b</sup>

<sup>a</sup> Between groups.

<sup>b</sup>  $p \leq 0.05$ ; ns = not significant.

*Note:* From Porretta, S. et al., *Food Chemistry*, 47, 1993.

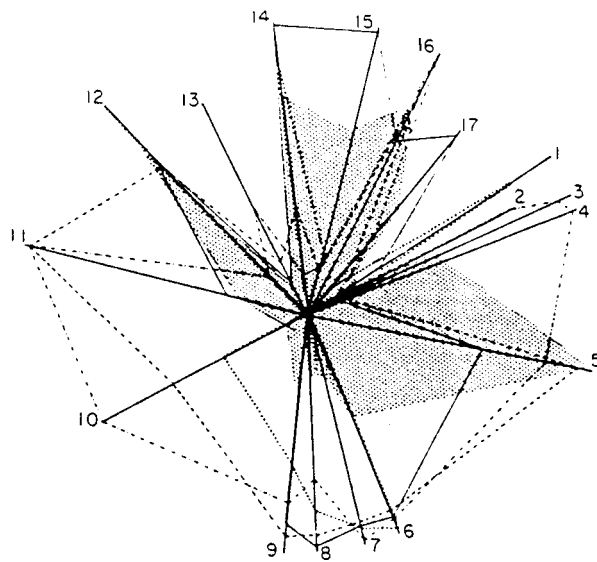

**FIGURE 24.** Profiles of tomato pulps with the highest quality. Key to polar coordinate scales: 1 = drained weight; 2 = sodium chloride; 3 = glucose; 4 = fructose; 5 =  $a_w$ ; 6 = D-lactate; 7 = L-lactate; 8 = total acidity; 9 = volatile acidity; 10 = color of serum; 11 = Bostwick consistency; 12 = natural taste; 13 = acid taste; 14 = pectic acid; 15 = protopectin; 16 = viscosity (sensorial); 17 = pectates. The shaded area represents the mean QDA profile. (From Porretta, S. et al., *Lebensmittel Wissenschaft and Technologie*, 25, 5, 1992.)

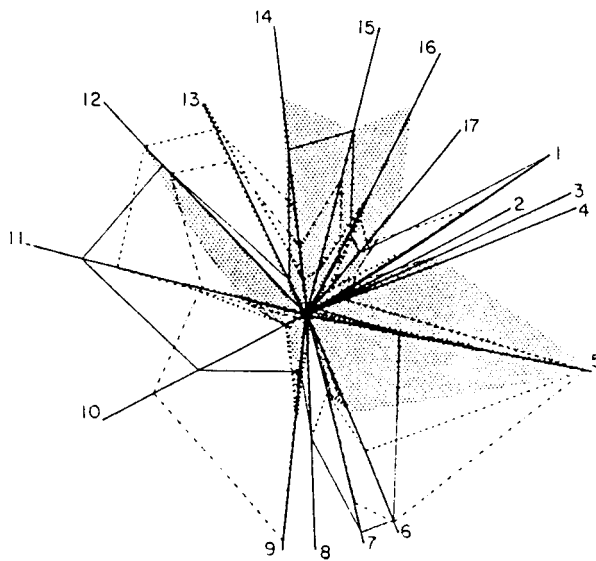

**FIGURE 25.** Profiles of tomato pulps with the highest quality. Key to polar coordinate scales: 1 = drained weight; 2 = sodium chloride; 3 = glucose; 4 = fructose; 5 =  $a_w$ ; 6 = D-lactate; 7 = L-lactate; 8 = total acidity; 9 = volatile acidity; 10 = color of serum; 11 = Bostwick consistency; 12 = natural taste; 13 = acid taste; 14 = pectic acid; 15 = protopectin; 16 = viscosity (sensorial); 17 = pectates. The shaded area represents the mean QDA profile. (From Porretta, S. et al., *Lebensmittel Wissenschaft and Technologie*, 25, 5, 1992.)

Floros et al. (1992) carried out a comprehensive study on raw diced tomatoes in which  $\text{CaCl}_2$  concentration (0.05, 0.75, and 1.45%), solution

temperature (35°, 50°, and 65°C), and treatment time (0.5, 2.0, and 3.5 min) were evaluated. The relative merit of each treatment combination was

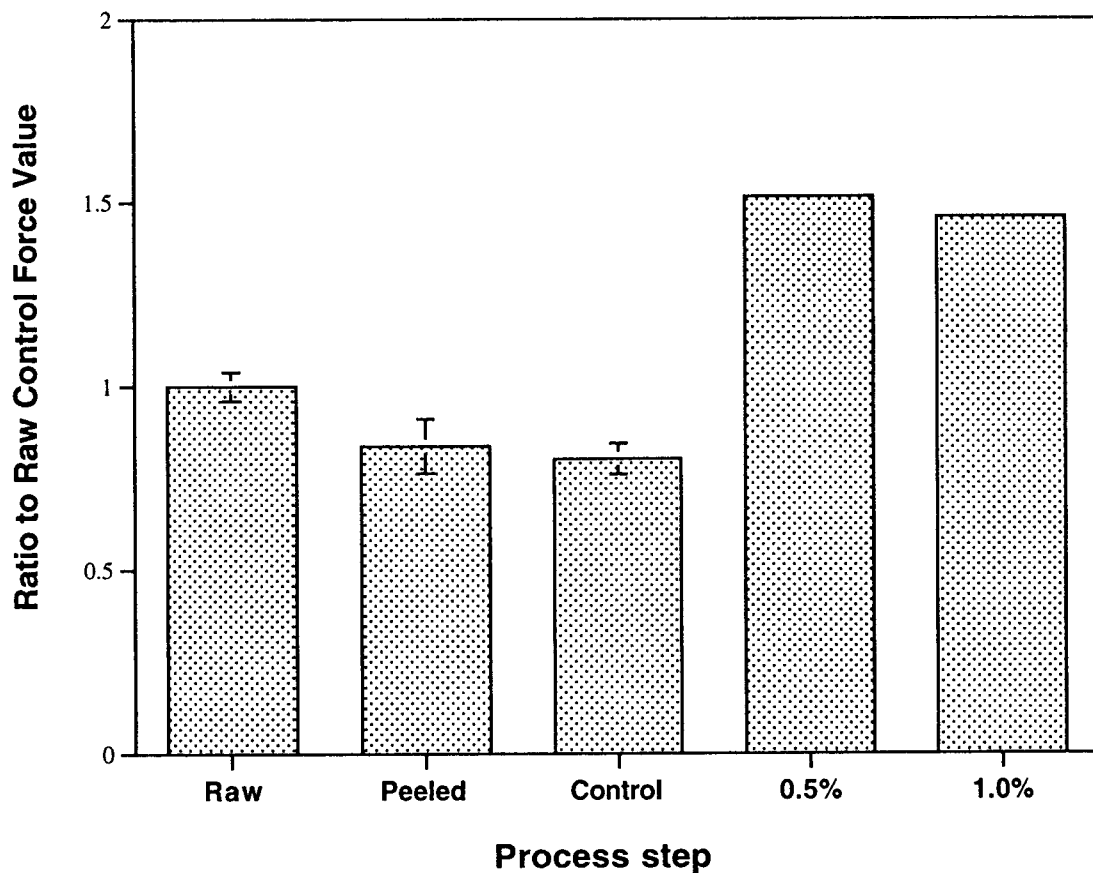

FIGURE 26. Textural modification in diced tomatoes by addition of calcium chloride.

evaluated in terms of calcium uptake, firmness (shear press), and pH. Calcium content and treatment time were highly significant factors, but these authors found that temperature had no significant effect on the process of calcium uptake or firming. Response surface methodology was used to determine that optimal conditions for production of diced tomatoes with less than 800 ppm calcium utilized approximately 0.43%  $\text{CaCl}_2$  and a 3.5-min treatment time.

In a recent study (Porretta et al., 1995) quite similar to that conducted by Floros et al. (1992), the effect of calcium concentration (0.05 to 1.05%  $\text{CaCl}_2$ ), temperature of dipping solution (40 to 60°C), and contact time (1 to 5 min) on calcium uptake, physico-chemical parameters, and sensory attributes of canned diced tomatoes were evaluated using response surface methodology. Analysis of variance results for the overall effect of the three process variables,  $\text{CaCl}_2$  concentra-

tion, temperature of dipping solution and contact time, on attributes is presented in Table 23.

Calcium concentration was the most important variable; however, contrary to results determined by Floros, temperature of the dipping solution did also affect some quality attributes. Pectate concentration, drained weight, pH, total acidity, calcium content in both dices, and final product and sensory properties were all significantly affected by calcium concentration. In most cases the higher the calcium concentration the better the quality attribute; however, sensory acceptability limited the addition of calcium concentrations above 0.7% (0.75 mg  $\text{kg}^{-1}$  in the final product). Increasing dipping solution temperature resulted in increased drained weight and calcium content in both dices and final product. The authors did not note a deleterious effect of temperature on the textural integrity of dices. Contact time had a significant overall effect on calcium uptake, but

**TABLE 23**  
**Analysis of Variance for the Overall Effect of Three Process Variables on Responses**

Input process variables	pH	Color (a/b)	Drained weight	Total acidity	Pectic acids	Pectates	Proto-pectins	Ca <sup>♦♦</sup> indices	Ca <sup>♦♦</sup> in final product	Sweet taste	Acid taste	Natural taste
CaCl <sub>2</sub>	10.4 <sup>a</sup>	7.2 <sup>c</sup>	15.2 <sup>a</sup>	8.9 <sup>b</sup>	0.1	38.1 <sup>a</sup>	0.01	23.1 <sup>a</sup>	19.2 <sup>a</sup>	8.9 <sup>a</sup>	6.6 <sup>a</sup>	2.6 <sup>a</sup>
Dipping temperature	0.4	0.3	7.7 <sup>b</sup>	0.6	0.2	2.4 <sup>b</sup>	0.01	15.4 <sup>a</sup>	1.2	0.48 <sup>c</sup>	1.0 <sup>c</sup>	2.03 <sup>c</sup>
Contact time	3.7 <sup>c</sup>	0.4	4.1	1.2 <sup>c</sup>	0.1	1.6 <sup>b</sup>	0.01	7.7 <sup>b</sup>	13.6 <sup>a</sup>	0.01	0.9	0.02

<sup>a</sup> Significant at 1% probability level.

<sup>b</sup> Significant at 5% probability level.

<sup>c</sup> Significant at 10% probability level.

From Porretta, S. et al., *Sciences des aliments*, 15, 1995.

only a slight effect on pH, color, total acidity, drained weight, and pectin content. Optimal conditions suggested were a dip in 0.75% CaCl<sub>2</sub> for 1 min at a temperature no greater than 40°C (Porretta et al., 1995).

In another recently reported Italian investigation, Castaldo et al. (Castaldo et al., 1995) immersed tomato dice in pH 7.5 saline solutions containing up to 800 mg/l of calcium, with and without the addition of the enzyme pectin methylesterase (PME), for times up to 30 min. Use of the pH 7.5 solutions alone resulted in significant improvements in both product consistency (texture evaluation by shear press) and drained weight (Figure 27). The authors suggested that improved textural properties were a consequence of increased activity of endogenous pectin methylesterase, which is known to have an optimal activity in the alkaline pH region. However,

even better results were obtained with solutions containing a combination of 400 to 800 mg/l of calcium and about 5 U/ml of PME for contact times of no longer than 15 min. The consistency of these products was almost 300 times higher than that of the non-treated product (Figure 28).

In a subsequent study, Castaldo et al. (Castaldo et al., 1995) used a slightly lower pH solution (pH 6.5) and higher PME activity levels in order to optimize the effect of added enzyme and calcium on dice texture. The PME activity added to the calcifying solutions ranged from 0 to 30 U/ml, and the contact time from 0 to 30 min. The highest consistency increase was observed in the range of added PME from 6 to 12 U/ml (Figure 29). The authors found that too much additional enzyme activity was undesirable; however, possibly resulting in more extensive deesterification of the pectic fractions and consequent tissue lysis.

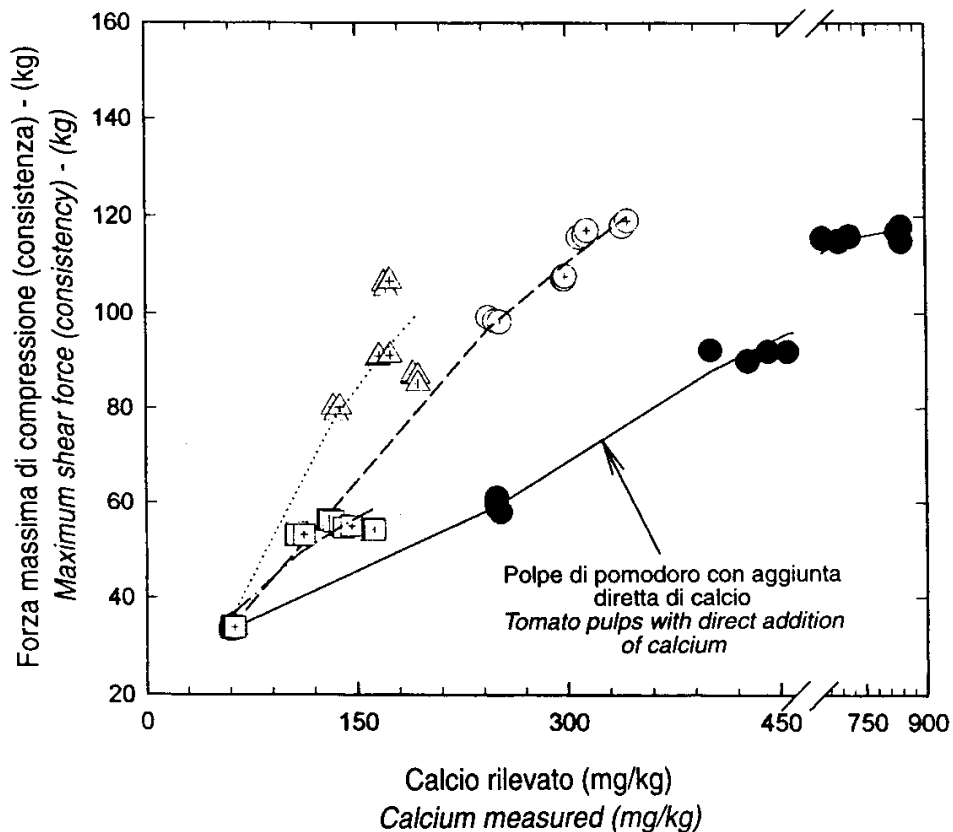

**FIGURE 27.** Comparison between product consistency with direct addition of calcium and with addition by immersion (pH 7.5). (From Castaldo, D. et al., *Industrie Conserve*, 70 (1), 1995.)

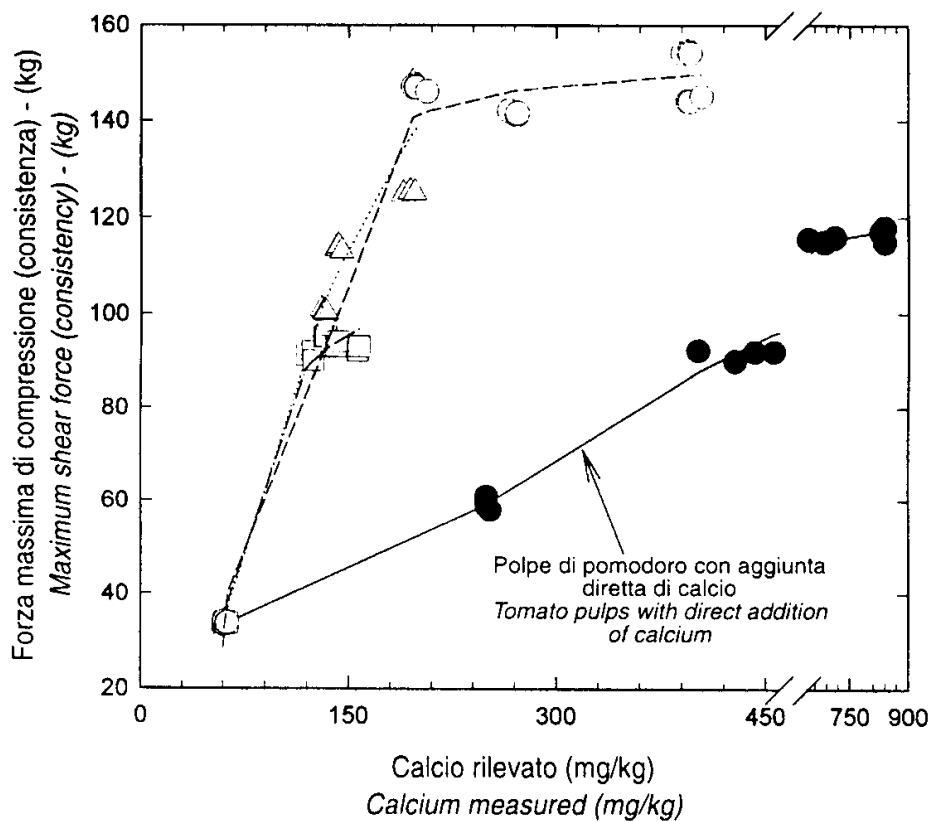

**FIGURE 28.** Comparison between product consistency with direct addition of calcium and with addition by immersion (pH 7.5). (From Castaldo, D. et al., *Industrie Conserve*, 70 (1), 1995.)

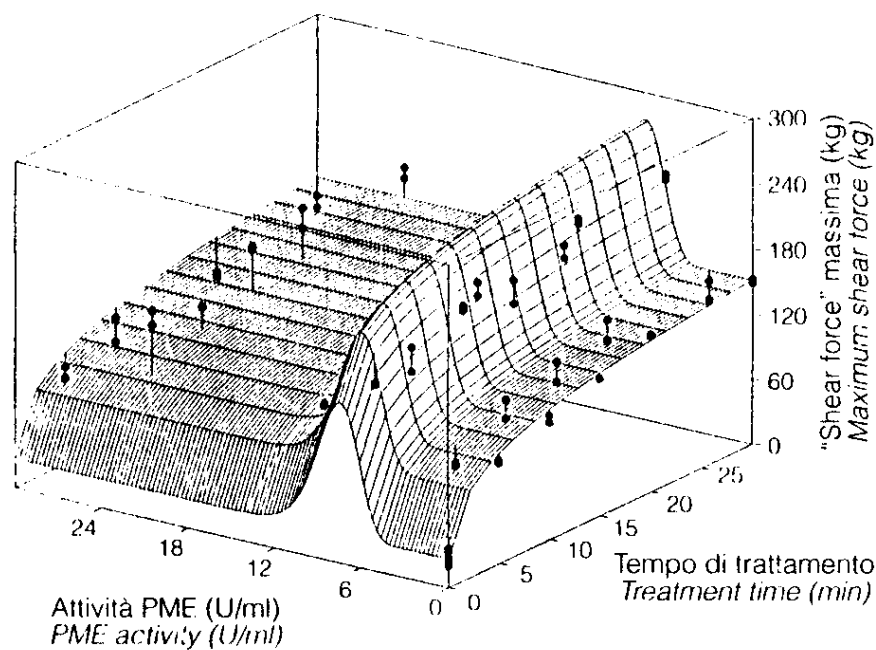

**FIGURE 29.** Effect of PME activity and treatment time on product consistency during the calcifying process. (From Castaldo, D. et al., *Industrie Conserve*, 70 (2), 1995.)

Since the early 1940s researchers have known about calcium-associated firming, and this effect is specific to calcium and not necessarily to other divalent cations. De Giorgi et al. (De Giorgi et al., 1994) used a shear press fitted to an Instron to measure the effects of both  $\text{CaCl}_2$ ,  $\text{MgCl}_2$ , and their combination on the mechanical properties of tomato dice. Although both are divalent ions, calcium salts (up to 500 mg/kg) significantly improved the textural properties of diced tomatoes, while magnesium salts did not.

#### **4. Thermal Processing Operations**

Until about 1990 there was very little in the scientific literature concerning optimal processing and quality parameters for these types of products, most likely because their success was so rapid. Recently, a number of well-conducted studies have been carried out both in the U.S. and Europe and these are reviewed. Diced, chopped, and crushed products are subjected to both high temperatures and shear stresses as they pass through pumps, pipes, strainers, valves, pressurized tanks, and fillers. In addition, Gould (Gould, 1992) estimated that 80% of the diced tomatoes processed today are bulk processed and thermally or aseptically filled into cans and drums for later remanufacture. Textural integrity of the final formulated product therefore will be dictated by thermal and mechanical abuses experienced both in the initial bulk processing and during remanufacture.

In a novel study, Porretta et al. (Porretta et al., 1992) evaluated the characteristics of tomato pulp (crushed or diced tomatoes with about 30% tomato juice as packing medium) canned with tomato juice enriched by ultrafiltration (UF) as a packing medium and compared this to those using conventional vacuum-concentrated juice. UF does not heat application and removes only water and low MW solids; therefore, it was thought to have potential in removing the compounds that may cause syneresis on storage. After 4 to 6 months storage, packing mediums in which 20 and 37% serum reduction had been accomplished by UF were found to be superior in color, reduction of browning, and Bostwick consistency. However, acidity and volatiles were lower, probably due to the removal of low MW solids. In addition, total

solids an drained weight were significantly lower in UF-treated products; therefore, commercial application may not be desirable. Drained weights may have been lowered due to the reduction in low MW pectic materials, which may increase drained weight due to their physical adherence to diced particulates. Perhaps the use of a lower MW cutoff UF membrane in order to retain more soluble pectins would have resulted in better overall textural properties.

#### **D. Tomato Pulp or Puree**

##### **1. Grades and Standards**

Tomato pulp or puree is covered by USDA Standards for Grades and by an FDA Standard of Identity. This product must contain at least 8.0% tomato solids, but less than 24.0% of salt-free tomato solids. Although puree grade is based primarily on color and absence of defects, the product description does define “fine” and “coarse” puree texture. Fine texture means a smooth, uniform finish, while coarse is defined as coarse with a slightly grainy finish. There are two general types of tomato pulp, one made from whole tomatoes and the other made from tomato byproducts such as the skins and cores from canning tomatoes or the partially extracted tomatoes from the manufacture of tomato juice (Gould, 1992).

Italy, which is the second largest producer of tomato puree, does not mention this product in their food regulations (Porretta, 1993), but evaluates puree quality by many of the same procedures used for paste (i.e., total solids, pH, total acidity, volatile acidity, color, salt, fructose, and glucose). Commercial Italian tomato puree, or “passato”, typically contains no less than 6% but less than 18% natural tomato solids. Mold counts commonly permissible in tomato puree are the same as those allowed for high-quality paste products, for example, 70% by the European Community and 50% by Italian standards.

##### **2. Definition of Quality**

Porretta (Porretta, 1993) evaluated a number of physicochemical properties of commercial to-

mato puree (8 to 14°Brix) and correlated these with typical sensory attributes. Puree samples were obtained from five traditional and five organic European processors, and all samples had a mold content between 14 to 46%, which was less than both the European Community and Italian limits. Only one organically produced sample showed traces of pesticide residues. It is interesting to see the range in physical, chemical, and sensory attributes obtained from the 10 puree products. In terms of the texture-related properties evaluated, there was a significant correlation between total solids and soluble solids ( $r = 0.96$ ), a weak correlation between Bostwick consistency and pectates ( $r = -0.60$ ), and a poor correlation between Bostwick consistency and sensory viscosity assessment ( $r = 0.22$ ). The author claimed that cluster analysis revealed the existence of two distinct subgroups, traditionally and organically produced tomato puree, but did not specify the qualitative differences.

### 3. Thermal Processing Operations

Luh and Daoud (Luh and Daoud, 1971) evaluated the effect of break temperature and holding time on the chemical and physical properties of canned tomato pulp and on the activity of polygalacturonase (PG) and pectin esterase (PE). Both gross viscosity (measured by Brookfield viscometer) and serum viscosity (measured by Ostwald viscometer) of the canned tomato pulp increased and total pulp and serum pectin decreased as the break temperature was raised from 140° to 240°F. The effect of break temperature on both gross and serum viscosity was much greater than that of holding time (Figures 30 and 31). The authors explained these results in terms of inactivation of pectic enzymes at higher break temperatures and longer holding periods. Pectinesterase (PE) and polygalacturonase (PG) activity decreased significantly as break temperature and holding time increased (Table 24). For both enzymes there was

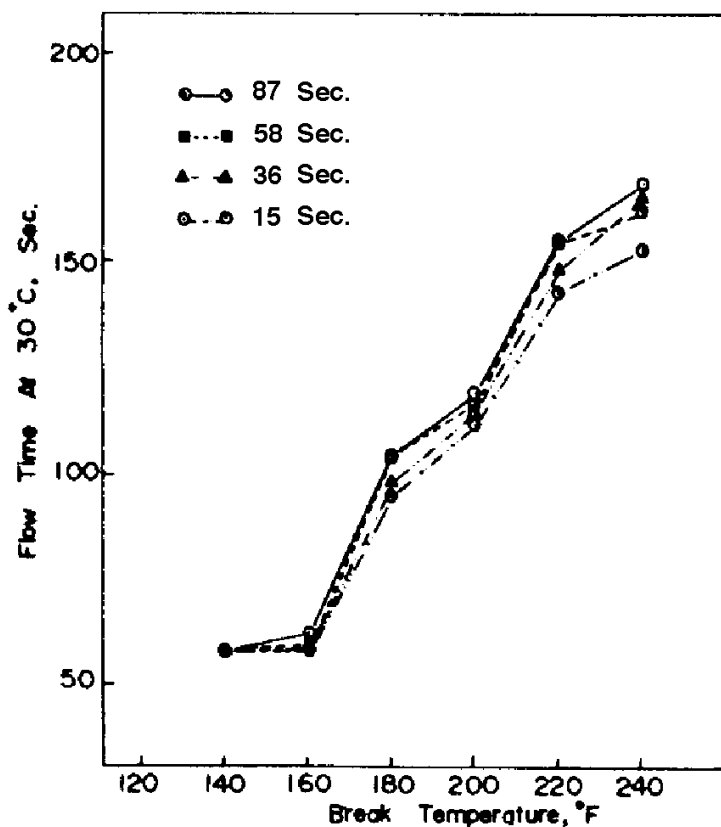

**FIGURE 30.** Effect of break temperature and holding time on serum viscosity of canned tomato pulp. (From Luh, B. S. and Daoud, H. N., *J. Food Sci.*, 36, 1971.)



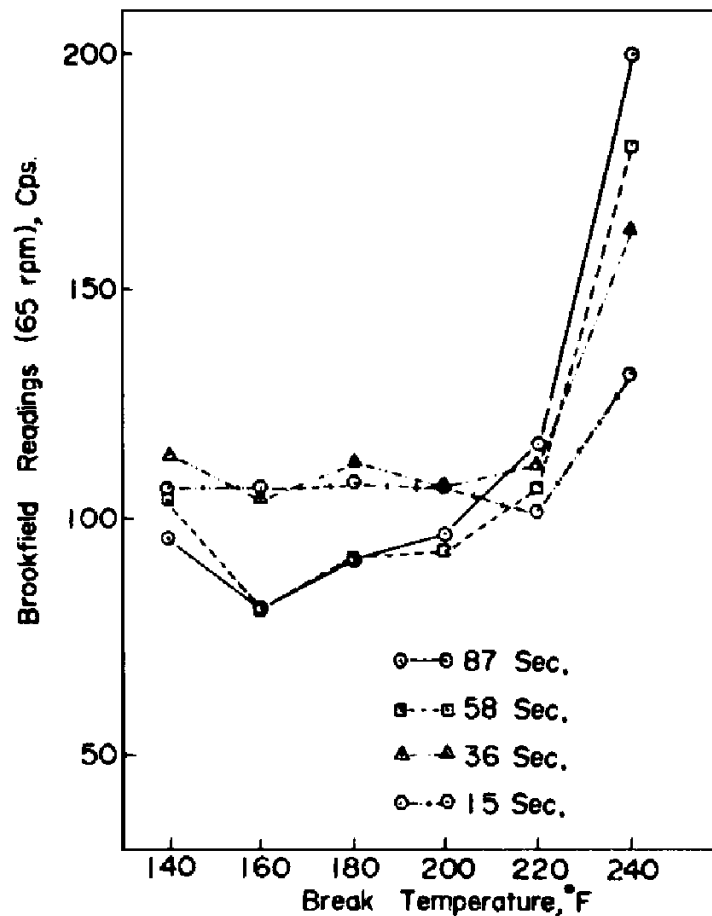

**FIGURE 31.** Effect of break temperature and holding time on consistency of canned tomato pulp. (From Luh, B. S. and Daoud, H. N., *J. Food Sci.*, 36, 1971.)

a critical temperature required for inactivation, for example, 180°F for 15 s for PE and 220°F for 15 s for PG.

In a later study, Heil et al. determined the heat-resistance parameters of endogenous pectin esterase and polygalacturonase enzymes prepared from tomato homogenates (Heil et al., 1989). The addition of 0.44% (pH 3.76) gluconic acid as an acidulant reduced the heat resistance of pectin esterase and eliminated gel formation in canned whole peeled tomatoes. However, heat inactivation of tomato PG was not significantly affected by the addition of up to 1.65% by wt gluconic acid. Both pectic enzymes in canned whole peeled tomatoes packed in juice in 303 × 406 cans were inactivated in 35 min at 98.9°C and 101.7°C, 26 min at 110.0°C, and 25 min at 118.3°C. These authors noted that inactivation times for extracted

pectic enzymes reported previously by Luh and Daoud were much shorter than those required in their study, which evaluated crushed tomato homogenates. It was suggested that extraction and removal of enzymes from their natural environment, which may include the presence of protective compounds, may be the difference.

## E. Tomato Juice

### 1. Grades and Standards

Canned tomato juice is covered by USDA Standards for Grades and by the FDA Standard of Identity, Quality, and Fill of Container. Tomato juice grades are determined by color, consistency, defects, flavor, and soluble solids content. In this

**TABLE 24**  
**Effect of Break Temperature and Holding Time on PE and PG**  
**Activity in Tomato Pulp**

Code	Treatment temp. and time	Enzyme activity		
		PE activity (PEu) <sub>g</sub>	PG activity	
			% loss in viscosity per min	Retention %
26	240°F–87 s	None	None	None
27	240°F–58 s	None	None	None
28	240°F–36 s	None	None	None
29	240°F–15 s	None	None	None
30	220°F–87 s	None	None	None
31	220°F–58 s	None	None	None
32	220°F–36 s	None	None	None
33	220°F–15 s	None	None	None
34	200°F–87 s	None	0.50	3.54
35	200°F–58 s	None	0.56	3.97
36	200°F–36 s	None	0.61	4.32
37	200°F–15 s	None	0.66	4.68
38	180°F–87 s	None	0.96	6.81
39	180°F–58 s	None	1.23	8.72
40	180°F–36 s	None	1.51	10.71
41	180°F–15 s	None	1.70	12.06
42	160°F–87 s	$3.68 \times 10^{-3}$	3.24	22.99
43	160°F–58 s	$4.00 \times 10^{-3}$	4.12	29.24
44	160°F–36 s	$4.72 \times 10^{-3}$	5.56	39.46
45	160°F–15 s	$6.24 \times 10^{-3}$	6.25	44.35
46	140°F–87 s	$4.12 \times 10^{-3}$	5.69	40.38
47	140°F–58 s	$4.20 \times 10^{-3}$	7.18	50.95
48	140°F–36 s	$4.76 \times 10^{-3}$	7.76	55.07
49	140°F–15 s	$5.56 \times 10^{-3}$	8.46	60.04
50	Cold break	$19.60 \times 10^{-3}$	11.75	83.39
Raw	Frozen tomato raw material	$26.24 \times 10^{-3}$	14.09	100.00

From Luh, B. S. and Daoud, H. N., *J. Food Sci.*, 36, 1971.

case, consistency is defined as the viscosity of the juice, including the degree of separation of the insoluble solids (Gould, 1992). Grade A is required to have “good” consistency, while Grade B should be of “reasonably good consistency”. The following are more specific definitions from the U.S. Standards:

1. *Good consistency:* Juice flows readily, has a normal amount of insoluble tomato solids in suspension, and there is little solids separation.

2. *Reasonably good consistency:* Juice flows readily, has a normal amount of insoluble tomato solids in suspension, and there is not a market degree of solids separation.

## 2. Thermal Process Operations

In juice and other tomato products with a relatively low WIS content (approximately 1%), the textural properties are determined not only by the WIS/TS ratio, but also by the characteristics

of the WIS particles (Whittenberger and Nutting, 1957) and the serum viscosity (Marsh et al., 1980). Tomato juice serum behaves as a Newtonian liquid (Tanglertpaibul and Rao, 1987), but as total solids content increases it more non-Newtonian, probably due to the presence of soluble pectins.

In 1944, Kertesz and Loconti (Kertesz and Loconti, 1944) stated quite accurately that among the properties that determine the commercial value of canned tomato juice, consistency seems to be the least understood. The interplay between pectic substances and cellulosic wall materials in tomato consistency was first described by Whittenberger and Nutting (Whittenberger and Nutting, 1957; Whittenberger and Nutting, 1958), who found that the more finely divided the cellulosic wall materials, the thicker the consistency of the juice, providing the pectin substances had not been degraded by too much by processing. This applied also to pastes in which the pH was held at the proper levels during manufacture. Reeve et al. (Reeve et al., 1959) found that in "puff-dried" tomato juice, a high frequency of intact cells appeared to be important to maintaining a stable suspension when the powder was reconstituted to a juice. The degree of comminution and thermal treatment applied to paste significantly affects paste consistency.

Sometimes tomato juice is homogenized to generate a product of thicker consistency and to prevent settling of the solids. However, the homogenization step is usually eliminated, particularly when hot break juice is being processed. Thakur et al. (Thakur et al., 1995) found that pressurized homogenization (up to 3000 psi) of tomato juice at room temperature (28°C) resulted in increased consistency and reduced serum separation in hot and cold break juice. The magnitudes of change in cold break juice were smaller than those in hot break juice, and increasing pressurization temperature resulted in only a small increase in consistency. The authors contributed increased consistency to the shredding, stirring, and breaking actions induced by pressurized homogenization, which resulted in more linear cell walls and reduced particle size.

The rheological properties of tomato juice, puree, and paste are strongly affected by the thermal treatment during hot or cold break. In some

cases, product may be held in evaporation systems for 3 to 4 h at various temperatures, and may spend minutes at temperatures as high as 110°C (Caradec and Nelson, 1985). As discussed above, Luh and Daoud (Luh and Daoud, 1971) found that both consistency and serum viscosity are improved when higher break temperatures are used. Caradec and Nelson (Caradec and Nelson, 1985) determined serum viscosity of canned tomato juice that was processed at 82°C, 102°C, and 112°C. Heat treatments applied for 2 h significantly affected serum viscosity, with the 82°C process showing a 17 to 30% loss of serum viscosity and the 112°C process a 67 to 82% loss, depending on the tomato variety.

Xu et al. (Xu et al., 1986) evaluated the rheological properties of both juice and paste produced from three varieties at break temperatures of 85°, 96°, and 107°C. A Weissenberg rheogoniometer was fitted with a cone and plate for tomato juice evaluation and with two flat parallel plates for measurement of paste viscosity. These authors found that apparent viscosity depended both on tomato variety and process temperature, with the highest viscosity achieved through use of the 107°C break temperature (Table 25). It was suggested that both pectic enzymes were still active at 96°C, while a temperature of 107°C was sufficient for inactivation and hence improved pectin retention and viscosity. Tomato juice was canned and exposed to processing temperatures of 82°C, 102°C, and 112°C. Serum viscosity was measured after 30, 60, and 120 min at each temperature. Heat treatment affected serum viscosity. A temperature of 82°C applied for 2 h resulted in a 17 to 30% loss of serum viscosity depending on the cultivar. Treatment at 112°C applied for 2 h caused 67 to 82% loss, again depending on the cultivar.

Juice samples were also evaluated for microstructural differences and samples processed at lower temperatures had coarser cell wall debris than those processed at 107°C, which appeared as a much finer network. Paste samples processed from 107°C hot break juice also seemed to have a finer, more highly disrupted cell structure than those produced from lower temperature break juice. The authors noted that, in addition to differences in cellular debris, more soluble pectin ap-

**TABLE 25**  
**Power Law Parameters Consistency Index and Flow**  
**Index in Tomato Juice Processed from 4 Cultivars at**  
**3 Different Break Temperatures**

Cultivar	Break temperature °C					
	85		96		107	
	k <sup>a</sup>	n	k	n	k	n
E6203	72.44	0.174	83.17	0.160	147.91	0.151
FM785	63.09	0.188	72.44	0.194	117.48	0.149
Murietta	60.25	0.176	69.18	0.174	91.20	0.132
H2152	41.68	0.208	72.44	0.183	134.89	0.113

<sup>a</sup> The units of k are 10<sup>-1</sup> N.s<sup>n</sup>/m<sup>2</sup>.

From Xu, S-Y et al. *J. of Food Sci.*, 51, 2, 1986.

peared to have leached out of cells in the high-temperature break juice. These pectins seemed to have coated collapsed cell walls, perhaps allowing for more water binding and improved consistency. Rha (Rha, 1978) suggested that the presence of pectic substances on the outside of cells creates a sticky, charged, and adhesive surface and may result in an increase in hydrodynamic volume and thereby consistency. It is interesting to note that high break temperatures may cause the same structural changes as those observed in homogenization (Whittenberger and Nutting, 1957; Ouden, 1995), that is, a more highly disrupted cell structure and improved consistency.

## F. Tomato Paste

### 1. Grades and Standards

Tomato paste is covered by USDA Standards for Grades and by FDA Standards of Identity and Quality. As with tomato puree, the grade for paste is based primarily on color and absence of defects; however, “fine” and “coarse” texture are defined as described above.

### 2. Thermal Process Operations

Tomato paste or concentrate exhibits shear thinning (Tanglerpaibul and Rao, 1987) and thixo-

tropic behavior and has a yield stress. Mathematical models have been designed to characterize the flow behavior of tomato concentrate (Rao, 1987), which according to Rao may be described satisfactorily by the power law model (Rao et al., 1981). In a fairly large study, Rao et al. evaluated the flow properties of over 70 pastes made from four tomato varieties. The apparent viscosity (100 s<sup>-1</sup>, 25°C) of the concentrates of each variety was proportional to the 2.5 power of the concentration (% total solids). The authors also found that the consistency index of the power law model also showed a power dependence on the concentration (Rao et al., 1981). Recently, McCarthy and Seymour (1994) compared experimental measurements for tomato sauce and other power law fluids to theoretical predictions. Although the flow behavior of tomato sauce differed significantly from other homogeneous fluids evaluated, it was possible to obtain a linear relationship when length was plotted vs. time<sup>0.2</sup>.

The concentration of tomato juice to paste effects the physical properties of the end product and although alternative technologies have been proposed, evaporation is still the most common technology today. Harper and El Sahrighi (1965) found a relationship between apparent viscosity at 500 sec<sup>-1</sup>, concentration and temperature for an evaporated tomato juice sample. They found that shear rate increased from 500 to 800 sec<sup>-1</sup> as total

solids increased from 12.8 to 30%. In an interesting approach, they attempted to reduce serum separation by removing juice insoluble solids by centrifugation, concentrating the serum by evaporation to 65°Brix, and reconstituting the various components. Unfortunately, apparent viscosities of the reconstituted samples were found to be only one-third that of the corresponding original concentrates.

Mannheim and Kopelman (1964) obtained similar results when they compared whole juice evaporation and serum evaporation after separation of the pulp by centrifugation. However, juice was obtained using cold break (60°C) temperatures; therefore, pectic enzymes were most probably active. The differences observed in apparent viscosity were suggested to be due to the centrifugation step, which may have crushed cells and reduced structural integrity, but it is more likely that the action of pectic enzymes reduced consistency.

Tanglertpaibul and Rao (1987) used a more carefully designed experimental plan to compare the apparent viscosities of pastes made by the traditional method of hot break juice evaporation (JE) to those obtained by serum evaporation (SE) or reverse osmosis (SRO). Although apparent viscosities of SRO and SE concentrates were not significantly different at low concentrations, at higher concentrations the viscosity of the less temperature-affected SRO pastes was higher. The apparent viscosities of pastes made by evaporation of hot break tomato juice were always lower than those obtained by centrifugation followed by either evaporation or reverse osmosis of the separated serum and remixing. Therefore, there may be improvements in textural properties realized through separation of tomato juice serum and preferably non-thermal concentration, followed by recombination with pulp.

A number of investigators have noted a “dilution loss” on rehydration of concentrated tomato paste. Marsh et al. (1977) used Bostwick measurements to show that concentrating paste to higher °Brix values resulted in lower consistency when the paste was subsequently diluted to 12% NTSS. Table 26 illustrates that, as an originally 8.6 Bostwick (12% NTSS) juice was diluted from 15 to 20, 21 to 25 and >25 NTSS concentrate, the

apparent Bostwick values increased to 9.5, 10.9, and 11.2 NTSS, respectively. In addition, Bostwick values increased significantly after samples were canned and stored for 3 months. The authors suggested that desiccation of the water-insoluble solids and inability to resorb water to the same degree as originally present were the reasons for their observations. To improve resorption, they incorporated a heat treatment (30 min at 100°C) after dilution of the paste to 12% NTSS.

Recently, Ouden (1995) also found that degree of paste concentration had a significant effect on the apparent viscosity of diluted, nonhomogenized suspensions. Figure 32 illustrates that the apparent viscosity of suspensions made from a 30°Brix concentrate was about 35% of that of the suspension prepared from the original 4.9°Brix juice. Ouden proposed that chemical changes may occur in tomato cells during concentration that affect resorption of water. Indeed, in another unpublished thesis by the same group, Heutink (1986) found that solubilization of highly esterified pectin occurred during hot break processing and resulted in a corresponding decrease in WIS pectin. However, WIS/TS ratios remained the same during processing and the author was unable to clarify a chemical change in the cell walls that would cause dilution loss.

Homogenization is known to increase apparent viscosity (Whittenberger and Nutting, 1957), and in the same thesis, Ouden found that the apparent viscosity of nonhomogenized tomato suspensions made from 30°Brix concentrate was about 65% lower than the original juice (Ouden, 1995). After homogenization, however, the difference was only about 10 to 15% (Figure 5A and B from above). The author attributed the decrease in viscosity of nonhomogenized suspensions to a decrease in diameter of tomato particles due to the concentration process. Nonhomogenized suspensions showed a significantly greater increase in serum separation during storage, which was thought to be caused by uniaxial compression of the network under its own weight. Ouden (1995) suggested that serum separation might continue until the gravitational force was counterbalanced by the product of the uniaxial compression modulus of the network and the deformation gradient. When tomato suspensions were homogenized, an

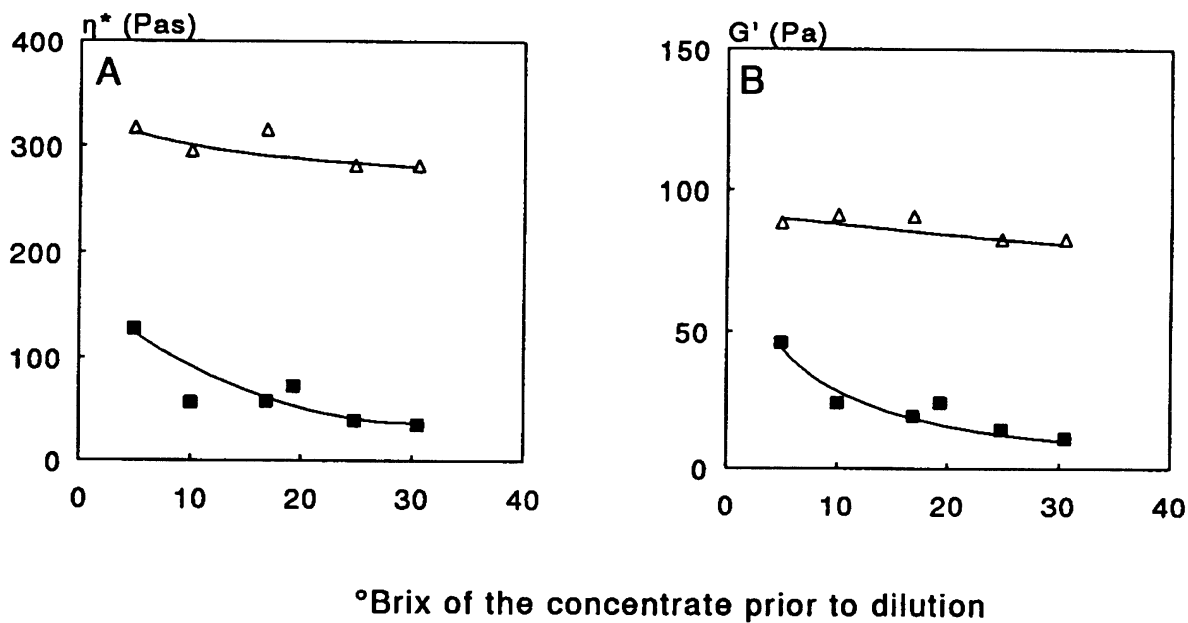

A. Apparent viscosity and B.  $G'$  as a function of °Brix of the concentrates before dilution to a suspension with 0.65% WIS, non-homogenized (■) and homogenized (△).

**FIGURE 32.** Apparent viscosity and storage modulus as a function of °Brix of concentrates. (Ouden, den, F. W. C., *Physico-chemical stability of tomato products*, Unpublished dissertation, Agricultural University, Wageningen, The Netherlands, 1995.)

increase in storage modulus ( $G'$ ) was observed and particle settling was retarded.

Tanglerpaibul and Rao (1987) measured shear rate-shear stress relationships in tomato pastes made from juices that were produced using the following finisher screen openings (FSO): 0.020, 0.027, 0.033, and 0.045 in. Although paste apparent viscosity at a shear rate of  $100 \text{ s}^{-1}$  generally increased with increasing FSO, use of the 0.027-in screen resulted in the highest apparent viscosity. The authors suggested that in choosing an optimal screen size one desires an increased surface area of small particles without excluding large particles that would result in a decrease in gross viscosity. The smallest screen used in this study (0.020 in) may have eliminated most of the large particles; therefore, the slighter larger screen size (0.027 in) resulted in better overall textural properties.

## G. Formulated Products

### 1. Salsa, Pizza, and Spaghetti Sauces

Salsa, pizza, and spaghetti sauces have not been defined by the FDA, or is there a voluntary U.S. grade standard established for them. Pizza sauce is generally evaporated to a specific gravity of approximately 1.035 or to a consistency of 6 to 8 on a Bostwick consistometer when measured hot.

### 2. Catsup

#### a. Grades and Standards

Tomato ketchup or catsup is covered by USDA Standards for Grades and by an FDA Standard of Identity. Only a product made from whole toma-

atoes may be called catsup without qualification. Pulp quality determines the final product quality and in inferior grades of catsup made from poor pulp, the flavor of the pulp must be overcome by added spices. The grade is based on color, consistency, absence of defects, and flavor. In this case consistency is defined as the viscosity of the product, and the tendency to hold its liquid portion in suspension. Grade A and B are defined as having “good consistency”, while Grade C should be of “fairly good consistency” (Gould, 1992). The following are more specific definitions from the U.S. Standards:

1. *Good consistency*: Catsup shows not more than a slight separation of free liquid when poured on a flat grading tray, is not excessively stiff, and flows not less than 3 cm but not more than 7 cm in 30 s at 20°C in a Bostwick consistometer.
2. *Reasonably good consistency*: Catsup may show noticeable but not excessive separation of free liquid when poured on a flat grading tray, is not excessively stiff, and flows not less than 2 cm but not more than 10 cm in 30 s at 20°C in a Bostwick consistometer.

Although the Standard of Identity for catsup does not specify a minimum concentration, the U.S. Standards for Grades of Ketchup require Standard ketchup to have a specific gravity of at least 1.11 (corresponding to about 25% total sol-

ids), Extra Standard to have a specific gravity of at least 1.13 (corresponding to 29% total solids), and Fancy ketchup must have a specific gravity of at least 1.15 (about 33% total solids).

### b. Thermal Process Operations

Tomato catsup quality is dictated to a large degree by its consistency and the degree of serum separation that occurs. Marsh et al. (Marsh et al., 1979) found that the consistency and serum separation in catsup were unrelated quality attributes. Consistency was directly dependent on tomato pulp WIS/TS ratio, while serum separation was found to depend on the break temperature used. Table 27 indicates the dramatic differences in serum viscosity resulting from hot break vs. cold break juice. It was determined that retention of at least 80% of the raw tomato serum viscosity was required for minimal serum flow.

### 3. Chili Sauce

Chili sauce differs from catsup in that the tomatoes are peeled, cored and chopped as for canning, however the seeds are not removed. Chili sauce generally contains more sugar and onions than catsup (Gould, 1992), and may be hotter due to the addition of cayenne pepper. Whereas catsup and paste manufacture may utilize small tomatoes, chili sauce production typically utilizes

**TABLE 26**  
**Effect of Concentration on the Bostwick Values Determined After Dilution to 12 NTSS**

True Bostwick 12 NTSS	Diluted from concentrate in the 15 to 20 NTSS range	Diluted from concentrate in the 21 to 25 NTSS range	Diluted from concentrate above the 25 NTSS range
8.6	9.5	10.9	11.2
8.2	8.0	9.2	10.3
6.7	7.0	7.6	8.3
5.3	6.3	7.0	7.5
2.5	3.0	3.2	3.9

From Marsh, G. I. et al., *J. Food Processing and Preservation*, 1, 1977.

**TABLE 27**  
**Effect of Pulping Temperature on the Yield and Quality of Catsup Produced from Tomato Paste**

Catsup, 33% total solids and 6 cm Bostwick consistency										
Pulping temperature	Composition of pulp					Quality factor	Yield factor	Lb of tomato solids per 100 lb Catsup yield factor x .33	Serum viscosity cps	Kramer shear press values lb
	Total solids w/w	Water insoluble solids w/w	Serum viscosity cps	Serum flow on blotter <sup>a</sup> cm	Percent of tomato solids in formulation; dry catsup solids basis					
	225°F (107°C)	6.00	0.69	4.9	4.2	39.7	13.1	22.0	—	
77°F (25°C)	6.13	0.61	1.0	9.2	57.3	18.9	3.5	—		
225°F (107°C)	4.65	0.80	3.9	4.2	31.8	10.5	—	25.5		
77°F (25°C)	4.43	0.57	1.0	9.4	40.6	13.4	—	14.0		
225°F (107°C)	4.65	0.62	4.5	4.8	35.7	11.8	27.3	21.5		
77°F (25°C)	4.51	0.56	0.9	9.8	50.0	16.5	2.4	13.5		
225°F (107°C)	6.30	0.63	5.8	4.8	42.7	14.1	37.0	23.0		
160°F (71°C)	6.06	0.62	1.0	9.9	44.8	14.8	2.5	13.0		
225°F (107°C)	6.25	0.64	3.3	5.0	46.7	15.4	29.5	19.5		
160°F (71°C)	5.98	0.65	1.7	8.9	47.9	15.8	4.4	15.0		
225°F (107°C)	5.17	0.54	2.6	4.9	40.6	13.4	21.0	18.1		
160°F (71°C)	5.26	0.59	1.8	9.0	42.4	14.0	3.0	12.8		
225°F (107°C)	4.85	0.72	3.8	5.2	41.8	13.8	14.8	—		
160°F (71°C)	4.84	0.72	1.2	10.7	44.2	14.6	2.5	—		

<sup>a</sup> From Marsh, G. L. et al., *J. Food Processing and Preservation*, 3 1979. (AU: where is 1 footnote?)



large to medium-sized tomatoes, depending on processor preference. Cooking and handling are the same as for ketchup, but the finishing operation is eliminated and the final product has more of a chunky texture than catsup.

Chili sauce has not been defined and therefore all of the ingredients must be stated on the label. A voluntary U.S. grade standard does exist; however, and grade is based on color, consistency, character, absence of defects, and flavor. Both A and C grades are specified, with Grade A chili sauce being of “good consistency” and Grade C being only of “fairly good consistency”. The following are more specific definitions from the U.S. Standards:

1. *Good consistency*: Heavy bodied sauce that, when emptied from the container to a flat surface, forms a moderately mounded mass and shows not more than a slight separation of free liquid at the edges of the mass.
2. *Fairly good consistency*: Sauce that, when emptied from the container to a flat surface, may tend to level itself or show a moderate separation of free liquid at the edges of the mass but is not excessively stiff or excessively liquid.

In addition to consistency, character attributes are also defined for chili sauce. In this case, character refers to the degree of disintegration of the tomatoes or the tenderness and texture of the other added ingredients. Definitions have been established for Grade A chili sauce, which should be of “good character” or Grade C, which is only “fairly good character”. The following are more specific definitions from the U.S. Standards:

1. *Good character*: Product does not have a finely comminuted appearance and that onion, celery, and other ingredients are tender, reasonably firm, or crisp in texture.
2. *Fairly good consistency*: Product may be finely comminuted and other vegetable ingredients may be only fairly tender.

## ACKNOWLEDGMENT

The authors acknowledge the assistance of Dr. Malcolm C. Bourne of Cornell University and

Dr. Robert Jackman of the University of Guelph in critically reviewing this manuscript. We acknowledge the collaboration of Ms. Charlene We and Dr. J. X. Guinard in generation of the sensory texture ballot (Table 1), and Dr. J. Jernstedt for her suggestions on anatomical terminology. Finally, we would like to acknowledge the hard work and diligence of Ms. Jean Seay in editing and proofing the final manuscript.

## REFERENCES

- Abbott, J. A., Affeldt, H. A., and Liljedahl, L. A. 1992. Firmness measurement of stored ‘Delicious’ apples by sensory methods, Magness-Taylor and sonic transmission. *J. Amer. Soc. Hort. Sci.*, **117**(4):590–595.
- Abbott, J. A., Bachman, G. S., Childers, N. F., Fitzgerald, J. V., and Matusik, F. J. 1968. Sonic techniques for measuring texture of fruits and vegetables. *Food Technology*, **22**:101–112.
- Abbott, J. A., Massie, D. R., Upchurch, B. L., and Hruschka, W. R. 1995. Nondestructive sonic firmness measurement of apples. *Transactions of the ASAE*, **38**(5):1461–1466.
- Abbott, J. A., Norris, K. H., and Watada, A. E. 1986. Maturity and chilling stress of tomato fruit measured by nondestructive DLE and optical techniques. *HortScience*, **21**(3):128.
- Adegoroye, A. S., Jolliffe, P. A., and Tung, M. A. 1988. Instrumental measures of texture of tomato fruit and their correlation with protopectin content: Effect of fruit size and stage of ripeness. *J. Fd. Sci. Technol.*, **25**(2):72–74.
- Ali, Z. M. and Brady, C. J. 1982. Purification and characterization of polygalacturonase of tomato fruits. *Aust. J. Plant Physiol.*, **9**:155–159.
- Atherton, J. G. E. and Rudich, J. 1986. *The tomato crop. 1st ed.* Chapman and Hall, London.
- Barrett, D. M. and Garcia, E. L. 1996. Report to the California League of Food Processors (unpublished).
- Barrett, D. M. and Garcia, E. L. In preparation. Varietal and maturity effects on texture of processed diced tomatoes.
- BeMiller, J. N. 1986. An introduction to pectins: structure and properties. In: *Chemistry and function of pectins*, Fishman, M. L. and Jen, J. J., Eds., Vol. ACS Symp. Ser. 310, pp. 2–12. American Chemical Society, Washington, D.C.
- Blumenkrantz, N. and Asboe-Hansen, G. 1973. A new method for quantitative determination of uronic acids. *Anal. Biochem.*, **54**:484.
- Bourne, M. C. 1966. Measure of compression and shear components of puncture tests. *J. Food Sci.*, **31**:282–291.
- Bourne, M. C. 1973. Use of the penetrometer for deformation testing of foods. *J. Food Sci.*, **38**:720–721.

- Bourne, M. C. 1978. Texture profile analysis. *Food Technology*, **7**:62–66, 72.
- Bourne, M. C. 1979. Rupture tests vs small-strain tests in predicting consumer response to texture. *Food Technology*, **10**:67–70.
- Bourne, M. C. 1980. Texture evaluation of horticultural crops. *HortScience*, **15**(1):7–13.
- Bourne, M. C. 1982. Effect of temperature on firmness of raw fruits and vegetables. *J. Food Sci.*, **47**:440–444.
- Bourne, M. C. 1982. *Food texture and viscosity*. 1st ed. Academic Press, New York.
- Bourne, M. C. 1983. Physical properties and structure of horticultural crops. 1st ed. In *Physical properties of foods*, Peleg, M. and Bagley, E. B., Eds., pp. 207–227. AVI Publishing Co. Westport, CT.
- Bourne, M. C. 1986. Effect of temperature on firmness of thermally processed fruits and vegetables. *J. Food Sci.*, **51**(2):531–533.
- Bourne, M. C. 1989. Applications of chemical kinetic theory of the rate of thermal softening of vegetable tissue. In: *Quality factors of fruits and vegetables*, Jen, J. J., Ed., Vol. ACS Symp. Ser. 405, pp. 98–110, American Chemical Society, Washington, DC.
- Bourne, M. C. 1993. Texture. 1st ed. In: *Encyclopaedia of Food Science, Food Technology and Nutrition*, Macrae, R., Robinson, R. K., and Sadler, M. J., Eds., pp. 4059–4065. Academic Press, London.
- Bourne, M. C. 1994. Converting from empirical to rheological tests on foods—it's a matter of time. *Cereal Foods World*, **39**(1):37–39.
- Brecht, J. K. 1987. Locular gel formation in developing tomato fruit and the initiation of ethylene production. *HortScience*, **22**:476–479.
- Brecht, J. K. 1991. Using X-ray-computed tomography to nondestructively determine maturity of green tomatoes. *HortScience*, **26**(1):45–47.
- Caradec, P. L. and Nelson, P. E. 1985. Effect of temperature on the serum viscosity of tomato juice. *J. Food Sci.*, **50**:1497–1498.
- Caradec, P. L., Nelson, P. E., and Takada, N. 1985. Tomato products: a new serum separation measurement. *J. Food Sci.*, **50**:1493–1494.
- Carey, A. T., Holt, K., Picard, S., Wilde, R., Tucker, G. A., Bird, C. R., Schuch, W., and Seymour, G. B. 1995. Tomato exo-(1④)-b-D-galactanase. Isolation, changes during ripening in normal and mutant tomato fruit, and characterization of a related cDNA clone. *Plant Physiol.*, **108**:1099–1107.
- Carpita, N. C. and Gibeaut, D. M. 1993. Structural models of primary cell walls in flowering plants: consistency of molecular structure with the physical properties of the walls during growth. *Plant Journal*, **3**:1–30.
- Castaldo, D., Impembo, M., Laratta, B., Villari, G., De Giorgi, A., Fasanaro, G., De Sio, F., and Giovane, A. 1995. Preparation of high consistency vegetable products: tomato pulps (Part 1). *Industria Conserve*, **70**:119–127.
- Castaldo, D., Servillo, L., Laratta, B., Fasanaro, G., Villari, G., De Giorgi, A., and Giovane, A. 1995. Preparation of high consistency vegetable products: Tomato pulps (Part II). *Industria Conserve*, **70**:253–258.
- Chang, C.-Y., Liao, H.-J., and Wu, T.-P. 1996. Relationships between the textural changes and the contents of calcium, magnesium ions, and non-freezing water in the alcohol-insoluble solids of snap bean pods during cooking processes. *Food Chemistry*, **55**:49–53.
- Chu, M. C.-Y. and Thompson, A. E. 1972. Comparative anatomy of pericarps of four tomato mutants. *J. Amer. Soc. Hort. Sci.*, **97**(4):478–481.
- Chuma, Y., Ohura, M., and Tagawa, A. 1982. Delayed light emission as a means of sorting tomatoes. *J. Fac. Agric. Kyushu Univ.*, **26**(4):159–167.
- Corey, K. A., Schlimme, D. V., and Frey, B. C. 1986. Peel removal by high pressure steam from processing tomatoes with yellow shoulder disorder. *J. Food Sci.*, **51**(2):388–390, 394.
- Davies, J. N. and Hobson, G. E. 1981. The constituents of tomato fruit - the influence of environment, nutrition and genotype. *CRC Critical Review in Food Science and Nutrition*, **15**(3):205–280.
- Davis, R. B., DeWeese, D., and Gould, W. A. 1953. Consistency measurement of tomato puree. *Food Technology*, **8**(7):330–334.
- De Giorgi, A., De Martino, E., Castaldo, D., and Impembo, M. 1994. Effect of the addition of calcium and magnesium salts on the firmness of cubed tomatoes: preliminary investigation. *Industria Conserve*, **69**:214–217.
- Esau, K. 1953. *Plant Anatomy*. John Wiley and Sons, New York.
- Fahn, A. 1974. *Plant Anatomy*. 2nd ed. Pergamon Press, Oxford.
- Finney, E. E., Jr. 1972. Vibration techniques for testing fruit firmness. *Journal of Texture Studies*, **3**:263–283.
- Finney, E. E., Jr. and Norris, K. H. 1968. Instrumentation for investigating dynamic mechanical properties of fruits and vegetables. *Trans. Am. Soc. Agr. Engrs.*, **11**:94.
- Fishman, M. L., Gillespie, D. T., and Sondey, S. M. 1991. Intrinsic viscosity and molecular weight of pectin components. *Carbohydrate Research*, **215**:91–104.
- Fishman, M. L., Gross, K. C., Gillespie, D. Y., and Sondey, S. M. 1989. Macromolecular components of tomato fruit pectin. *Arch. Biochem. Biophys.*, **274**:179–191.
- Fishman, M. L., Pepper, L., Damert, W. C., Phillips, J. G., and Barford, R. A. 1986. A critical examination of molecular weight and dimensions for citrus pectins. In *Chemistry and function of pectins*, Fishman, M. L. and Jen, J. J., Eds., Vol. ACS Symp. Ser. 310, pp. 22–37. American Chemical Society, Washington, D.C.
- Floros, J. D., Ekanayake, A., Abide, G. D., and Nelson, P. E. 1992. Optimization of a diced tomato calcification process. *J. Food Sci.*, **57**(5):1144–1148.
- Foreste, M. d. A. e. d. 1989. *Official Italian methods, metodi ufficiali di analisi per le conserve vegetali-Parte generale*. Istituto Poligrafico dello Stato, Roma, Italy.
- Fuchigami, M., Miyazaki, K., and Hyakumoto, N. 1995. Frozen carrots texture and pectic components as affected by low-temperature-blanching and quick freezing. *J. Food Sci.*, **60**(1):132–136.

- Giovannoni, J. J., DellaPenna, D., Bennett, A. B., and Fischer, R. L. 1989. Expression of a chimeric PG gene in transgenic rin (Ripening inhibitor) tomato fruit results in polyuronide degradation but not fruit softening. *Plant Cell*, **1**:53–63.
- Giovannoni, J. J., DellaPenna, D., Bennett, A. B., and Fischer, R. L. 1992. Polygalacturonase and tomato fruit ripening. *Hortic. Rev.*, **13**:67–103.
- Gormley, T. R. and Keppel, D. 1976. A method for measuring tomato fruit firmness using a modified shear press. *Journal of Food Technology*, **11**(6):607–617.
- Gould, W. A. 1992. *Tomato production, processing and technology*. 3rd ed. CTI Publications Inc., Baltimore, MD.
- Grierson, D. and Kader, A. A. 1986. Fruit ripening and quality. 1st ed. In *The tomato crop: a scientific basis for improvement*, Atherton, J. G. and Rudich, J., Eds., pp. 241–280. Chapman and Hall, London.
- Gross, K. 1984. Fractionation and partial characterization of cell walls from normal and non-ripening mutant tomatoes. *Physiol. Plant.*, **62**:25–32.
- Gross, K. and Wallner, S. J. 1979. Degradation of cell wall polysaccharides during tomato fruit ripening. *Plant Physiol.*, **63**:117–120.
- Gross, K. C. 1990. Recent developments on tomato fruit softening. *Postharvest News Inform.*, **1**:109–112.
- Hagerman, A. E. and Austin, P. J. 1986. Continuous spectrophotometric assay for plant pectin methyl esterase. *Journal of Agriculture and Food Chemistry*, **34**:440–444.
- Hall, C. B. 1987. Firmness of tomato fruit tissues according to cultivar and ripeness. *J. Amer. Soc. Hort. Sci.*, **112**(4):663–665.
- Harper, J. C. and El Sahrgi, A. F. 1965. Viscometric behavior of tomato concentrates. *J. Food Sci.*, **30**:470.
- Heil, J. R., McCarthy, M. J., McIntyre, D. J., and Merson, R. L. 1989. Influence of gluconic acid on thermal processing requirement for canned whole peeled tomatoes. *Journal of Food Processing and Preservation*, **13**:431–445.
- Heutink, R. 1986. Tomato juices and tomato juice concentrates: a study of factors contributing to their gross viscosity. Agricultural University, Wageningen, The Netherlands.
- Hobson, G. 1965. The firmness of tomato fruit in relation to polygalacturonase activity. *J. Hortic. Sci.*, **40**:66–72.
- Hobson, G. and Grierson, D. 1993. Tomato. In: *Biochemistry of fruit ripening*, Seymour, G. B., Taylor, J. E., and Tucker, G. A., Eds., pp. 405–442. Chapman and Hall, London.
- Hobson, G. E. 1968. Cellulase activity during the maturation and ripening of tomato fruit. *J. Food Sci.*, **33**:588–592.
- Holt, C. 1970. Measurement of tomato firmness with a universal testing machine. *Journal of Texture Studies*, **1**:491–501.
- Huber, D. J. 1985. A possible role for cellulose and Cx-cellulase activity in locular gel formation in tomato fruit. *Hort. Sci.*, **20**(3):442–443.
- Jack, F. J., Paterson, A., and Piggott, J. R. 1995. Perceived texture: direct and indirect methods for use in product development. *International J. Food Sci., and Technology*, **30**:1–12.
- Jackman, R. L. 1995. Components of tomato texture. *Tomato Quality Workshop*, Davis, California.
- Jackman, R. L., Marangoni, A. G., and Stanley, D. W. 1990. Measurement of tomato fruit firmness. *HortScience*, **25**(7):781–783.
- Jackman, R. L., Marangoni, A. G., and Stanley, D. W. 1992. The effects of turgor pressure on puncture and viscoelastic properties of tomato tissue. *Journal of Texture Studies*, **23**:491–505.
- Jackman, R. L. and Stanley, D. W. 1992. Area- and perimeter-dependent properties and failure of mature-green and red-ripe tomato pericarp tissue. *Journal of Texture Studies*, **23**:461–474.
- Jackman, R. L. and Stanley, D. W. 1992. Failure mechanisms of tomato pericarp tissue suggested by large and small deformation tests. *Journal of Texture Studies*, **23**:475–489.
- Jackman, R. L. and Stanley, D. W. 1995. Creep behaviour of tomato pericarp tissue as influenced by ambient temperature ripening and chilled storage. *Journal of Texture Studies*, **26**:537–552.
- Jackman, R. L. and Stanley, D. W. 1995. Perspectives in the textural evaluation of plant foods. *Trends in Food Science and Technology*, **6**:187–194.
- Jackman, R. L., Tregunno, N. B., Goff, H. D., and Stanley, D. W. in press. Tomato pericarp tissue resonance and its correlation with compression behavior. *Journal of Texture Studies*.
- Janoria, M. P. and Rhodes, A. M. 1974. Juice viscosity as related to various juice constituents and fruit characters in tomatoes. *Euphytica*, **23**:553–562.
- Johannessen, G. A. 1993. Enhancing tomato color. *California Tomato Grower*, **Jul/Aug**:12–13.
- Kader, A. A., Morris, L. L., and Chen, P. 1978. Evaluation of two objective methods and a subjective rating scale for measuring tomato fruit firmness. *Journal of American Society of Horticultural Scientists*, **103**(1):70–73.
- Kapsalis, J. G. and Moskowitz, H. R. 1977. The psychophysics and physics of food texture. *Food Technology*, **4**:91–94, 99.
- Keijbets, M. J. H., Pilnik, W., and Vaal, J. F. A. 1976. Model studies on behaviour of pectic substances in the potato cell wall during boiling. *Potato Res.*, **19**:289–303.
- Kertesz, Z. I. and Loconti, J. D. 1944. Factors determining the consistency of commercial canned tomato juice. New York State Agricultural Experiment Station. 272.
- Kertesz, Z. I., Tolman, T. G., Loconti, J. D., and Ruyle, E. H. 1940. The use of calcium in the commercial canning of whole tomatoes. New York State Agricultural Experiment Station, Geneva, NY. Technical Bulletin No. 252.

- Klein, J. D., Hanzon, J., Irwin, P. L., Ben-Shalom, N., and Lurie, S. 1995. Pectin esterase and pectin methylesterification in heated Golden delicious apples. *Phytochemistry*, **39**(3):491–494.
- Koch, J. L. and Nevins, D. J. 1989. Tomato fruit cell wall. I. Use of purified tomato polygalacturonase and pectinmethylesterase to identify developmental changes in pectins. *Plant Physiology*, **91**:816–822.
- Kramer, M., Sanders, R., Bolkan, H., Waters, C., Sheehy, R. E., and Hiatt, W. R. 1992. Postharvest evaluation of transgenic tomatoes with reduced levels of polygalacturonase: processing, firmness and disease resistance. *Postharvest Biology and Technology*, **1**:241–255.
- Lamb, F. C. 1977. Tomato products. National Canners Association. 27-L.
- Leonard, S. and Winters, F. 1974. Pilot application of freeze-heat peeling of tomatoes. *J. Food Sci.*, **39**:162–165.
- Lopez, A. 1996. *A Complete Course in Canning*. 13th ed. The Canning Trade, Baltimore.
- Luh, B. S. and Daoud, H. N. 1971. Effect of break temperature and holding time on pectin and pectic enzymes in tomato pulp. *J. Food Sci.*, **36**:1030–1043.
- Maclachlan, G. and Brady, C. 1992. Multiple forms of 1,4- $\beta$ -glucanase in ripening tomato fruits include a xyloglucanase activatable by xyloglucan oligosaccharides. *Aust. J. Plant Physiol.*, **19**:137–146.
- Mannheim, H. C. and Kopelmann, J. 1964. Evaluation of two methods of tomato juice concentration. II. Product comparisons. *Food Technology*, **18**:911–914.
- Marangoni, A. G., Jackman, R. L., and Stanley, D. W. 1995. Chilling-associated softening of tomato fruit is related to increased pectinmethylesterase activity. *J. Food Sci.*, **60**(6):1277–1281.
- Margen, S. and Letter, E. o. t. U. o. C. a. B. W. 1992. *The wellness encyclopedia of food and nutrition: How to buy, store, and prepare every variety of fresh food*. Rebus, New York.
- Marsh, G. L., Buhlert, J., and Leonard, S. 1977. Effect of degree of concentration and of heat treatment on consistency of tomato pastes after dilution. *Journal of Food Processing and Preservation*, **1**:340–346.
- Marsh, G. L., Buhlert, J. E., and Leonard, S. J. 1980. Effect of composition upon Bostwick consistency of tomato concentrate. *J. Food Sci.*, **45**(3):703–706, 710.
- Marsh, G. L., Leonard, S. L., and Buhlert, J. E. 1979. Yield and quality of catsup produced to a standard solids and consistency level. II. Influence of handling practices, break temperature and cultivar. *Journal of Food Processing and Preservation*, **3**:195–212.
- Marsh, G. L., Tombropoulos, D., Vilas, N., and Pearl, R. C. 1968. The effect of harvest maturity on the consistency and color of the concentrated tomato products. Dept. of Food Science and Technology, University of California-Davis. Unpublished data.
- McCarthy, K. L. and Seymour, J. D. 1993. A fundamental approach for the relationship between the Bostwick measurement and Newtonian fluid viscosity. *Journal of Texture Studies*, **24**:1–10.
- McCarthy, K. L. and Seymour, J. D. 1994. Gravity current analysis of the Bostwick consistometer for power law foods. *Journal of Texture Studies*, **25**:207–220.
- McCready, R. M. and McComb, E. A. 1952. Extraction and determination of total pectic materials in fruit. *Anal. Chem.*, **24**, 12:1986–1988.
- McFeeters, R. F. 1980. A manual method for reducing sugar determinations with 2,2' bicinchoninate reagent. *Analytical Biochemistry*, **103**:302–306.
- Mohr, W. P. 1987. Measuring consistency of tomato thin pulp and puree. *Canadian Journal of Plant Science*, **67**(3):919–921.
- Murase, H. and Merva, G. E. 1977. Static elastic modulus of tomato epidermis as affected by water potential. *Transactions of the ASAE*:594–597.
- Ouden, D. F. W. C. 1995. *Physico-chemical stability of tomato products*. Agricultural University, Wageningen, The Netherlands.
- Peleg, K., Ben-Hanan, U., and Hinga, S. 1990. Classification of avocado by firmness and maturity. *Journal of Texture Studies*, **21**:123–139.
- Peleg, M. 1980. The basics of solid foods rheology. 1st ed. In: *Food Texture: Instrumental and sensory measurement*, Moskowitz, H. R., Ed., Marcel Dekker, New York.
- Porretta, S. 1993. Analysis of sensory and physicochemical data on commercial tomato puree with pattern recognition techniques. *Lebensmittel Untersuchung und Forschung*, **197**:531–536.
- Porretta, S., Carpi, G., Dall'Aglio, G., and Ghizzoni, C. 1992. Use of ultrafiltration for preparing improved tomato pulp. *International Journal of Food Science and Technology*, **27**:427–433.
- Porretta, S., Poli, G., and Palmieri, L. 1995. Optimization of the addition of calcium chloride to canned diced tomatoes. *Sciences Des Aliments*, **15**:99–112.
- Porretta, S., Poli, G., Rondelli, M., and Zanangeli, G. 1992. Definition of tomato pulp quality using a multivariate QDA method. *Lebensmittel Wissenschaft und Technologie*, **25**(5):487–490.
- Porretta, S., Poli, G., Rondelli, M., and Zanangeli, G. 1993. Quality evaluation of tomato pulp. *Food Chemistry*, **47**:379–386.
- Pressey, R. 1983. Beta-Galactosidases in ripening tomatoes. *Plant Physiol.*, **71**(1):132–135.
- Pressey, R. 1986. Extraction and assay of tomato polygalacturonases. *Horticultural Science*, **21**(3):490–492.
- Pressey, R. and Avants, J. K. 1972. Multiple forms of pectinesterase in tomatoes. *Phytochemistry*, **11**:3139–3142.
- Pressey, R. and Avants, J. K. 1982. Solubilization of cell walls by tomato polygalacturonase: effects of pectinesterase. *J. Food Biochem.*, **6**:57–74.
- Rao, M. A. 1987. Predicting the flow properties of food suspensions. *Food Technology*: 85–88.
- Rao, M. A., Bourne, M. C., and Cooley, H. J. 1981. Flow properties of tomato concentrate. *Journal of Texture Studies*, **12**:521–538.

- Reeve, R. M. 1970. Relationships of histological structure to texture of fresh and processed fruits and vegetables. *Journal of Texture Studies*, **1**:247–284.
- Reeve, R. M., Kaufman, V. F., and Wong, F. F. 1959. Food Technology. *Microscopic structure and reconstitution of vacuum-dried tomato powders*, **13**:561.
- Resurreccion, A. V. A. and Shewfelt, R. L. 1985. Relationships between sensory attributes and objective measurements of postharvest quality of tomatoes. *J. Food Sci.*, **50**:1242–1245, 1256.
- Rha, C. 1978. Rheology of fluid foods. *Food Technology*, **7**:77–82.
- Sajjaanantakul, T., Van Buren, J., and Downing, D. L. 1989. Effect of methyl ester content on heat degradation of chelator-soluble carrot pectin. *J. Food Sci.*, **54**:1272–1277.
- Sakurai, N. and Nevins, D. J. 1993. Changes in physical properties and cell wall polysaccharides of tomato (*Lycopersicon esculentum*) pericarp tissues. *Physiologia Plantarum*, **89**:681–686.
- Salter, P. J. 1958. The effect of different water-regimes on the growth of plants under glass. IV. Vegetative growth and fruit development in the tomato. *Journal of American Society of Horticulture*, **104**:835–8.
- Saltveit, M. E., Jr. 1991. Determining tomato fruit maturity with nondestructive in vivo nuclear magnetic resonance imaging. *Postharvest Biology and Technology*, **1**:153–159.
- Saltveit, M. E., Upadhyaya, S. K., Happ, J. F., Caveletto, R., and O'Brien, M. 1985. Maturity determination of tomatoes using acoustic methods. *American Society of Agricultural Engineers (ASAE)*, **85(3536)**:1–8.
- Salunkhe, D. K., Jadhav, S. J., and Yu, M. H. 1974. Quality and nutritional composition of tomato fruit as influenced by certain biochemical and physiological changes. *Qual. Plant. - Plant Foods Human Nutr.*, **24(1/2)**:85–113.
- Sawamura, M., Knegt, E., and Bruisma, J. 1978. Levels of endogenous ethylene, carbon dioxide and soluble pectin, and activities of pectin methylesterase and polygalacturonase in ripening tomato fruits. *Plant Cell Physiol.*, **19**:1061–1069.
- Sayre, C. B., Kertesz, Z. I., and Loconti, J. D. 1940. Effect of calcium and potassium fertilizer on the firmness and calcium and potassium content of canned tomatoes. *Jour. Amer. Soc. Agron.*, **32**:5.
- Schuch, W. 1994. Improving tomato quality through biotechnology. *Food Technology*, **11**:78–83.
- Schuch, W., Kanczler, J., Robertson, D., Hobson, G., Tucker, G., Grierson, D., Bright, S., and Bird, C. 1991. Fruit quality characteristics of transgenic tomato fruit with altered polygalacturonase activity. *HortScience*, **26(12)**:1517–1520.
- Seymour, G. B. and Harding, S. E. 1987. Analysis of the molecular size of tomato (*Lycopersicon esculentum* Mill) fruit polyuronides by gel filtration and low-speed sedimentation equilibrium. *Biochemical Journal*, **245**:463–466.
- Seymour, G. B., Lasslett, Y., and Tucker, G. A. 1987. Different effects of pectolytic enzymes on tomato polyuronides *in vivo* and *in vitro*. *Phytochemistry*, **26(12)**:3137–3139.
- Seymour, J. D., Maneval, J. E., McCarthy, K. L., Powell, R. L., and McCarthy, M. L. 1995. Rheological characterization of fluids using NMR velocity spectrum measurements. *Journal of Texture Studies*, **26**:89–101.
- Shackel, K. A., Greve, C., Labavitch, J. M., and Ahmadi, H. 1991. Cell turgor changes associated with ripening in tomato pericarp tissue. *Plant Physiol.*, **97(2)**:814–816.
- Sheehy, R. E., Kramer, M. K., and Hiatt, W. R. 1988. Reduction of polygalacturonase activity in tomato fruit by antisense RNA. *Proc. Natl. Acad. Sci. USA*, **85**:8805–8809.
- Stanley, D. W. 1987. Food texture and microstructure. 1st ed. In: *Food texture: Instrumental and sensory measurement*, Moskowitz, H. R., Ed., pp. 35–64. Marcel Dekker, New York.
- Stanley, D. W., Bourne, M. C., Stone, A. P., and Wismer, W. V. 1995. Low temperature blanching effects on chemistry, firmness and structure of canned green beans and carrots. *J. Food Sci.*, **60(2)**:327–333.
- Stephens, T. S., Saldana, G., and Brown, H. E. 1973. Effects of different submergence times in hot calcium chloride on peeling efficiency of tomatoes. *J. Food Sci.*, **38**:512–515.
- Stephenson, K. Q., Byler, R. K., and Wittman, M. A. 1973. Vibrational response properties as sorting criteria for tomatoes. *Transactions of the ASAE*: 258–260, 265.
- Szczesniak, A. S. 1979. Recent developments in solving consumer-oriented texture problems. *Food Technology*, **10**:61–66.
- Szczesniak, A. S. 1987. Correlating sensory with instrumental texture measurements—an overview of recent developments. *Journal of Texture Studies*, **18**:1–15.
- Szczesniak, A. S., and Bourne, M. C. 1969. Sensory evaluation of food firmness. *Journal of Texture Studies*, **1**:52.
- Szczesniak, A. S., Brandt, M. A., and Fiedman, H. H. 1963. Development of standard rating scales for mechanical parameters of texture and correlation between the objective and sensory methods of texture evaluation. *J. Food Sci.*, **28**:397.
- Szczesniak, A. S., Humbaugh, P. R., and Block, H. W. 1970. Behaviour of different foods in the standard shear compression cell of the shear press and the effect of sample weight on peak area and maximum force. *J. Texture Studies*, **1**:356–378.
- Tanglerpaibul, T. and Rao, M. A. 1987. Flow properties of tomato concentrates: effect of serum viscosity and pulp content. *J. Food Sci.*, **52**:318–321.
- Thakur, B. R., Singh, R. K., and Handa, A. K. 1995. Effect of homogenization pressure on consistency of tomato juice. *J. Food Quality*, **18**:389–396.
- Thakur, B. R., Singh, R. K., Tieman, D. M., and Handa, A. K. 1996. Tomato product quality from transgenic fruits with reduced pectin methylesterase. *Food Sci.*, **61(1)**:85–108.

- Thomas, W. M., Mohr, W. P., Stanley, D. W., and Arnott, D. R. 1978. *Can. Inst. Food Sci. Technol. J.*, **11(4)**:209–215.
- Tieman, D. M., Harriman, R. W., Ramamohan, G., and Handa, A. K. 1992. An antisense pectin methylesterase gene alters pectin chemistry and soluble solids in tomato fruit. *Plant Cell*, **4**:667–679.
- Tucker, G. A. 1993. Introduction. In *Biochemistry of fruit ripening*, Seymour, G. B., Taylor, J. E., and Tucker, G. A., Eds., pp. 1–51. Chapman and Hall, London.
- Tucker, G. A., Robertson, N. G., and Grierson, D. 1982. Purification and changes in activities of tomato pectinesterase isoenzymes. *J. Sci. Food Agric.*, **33**:396–400.
- USDA. 1971. Methods of analysis for tomato products: Determination of consistency. United States Department of Agriculture, Consumer Marketing Service, Fruit and Vegetable Division, Processed Products Standardization and Inspection Branch.
- USDA. 1975. Color classification requirements in tomatoes. The John Henry Co., Lansing, MI.
- Van Buren, J. P. 1979. The chemistry of texture in fruits and vegetables. *J. Text. Stu.*, **10(1)**:1–23.
- Van Buren, J. P. and Pitiifer, L. A. 1992. Retarding vegetable softening by cold alkaline pectin deesterification before cooking. *J. Food Sci.*, **57(4)**:1022–1023.
- van Marle, J. T., Stolle-Mits, T., Donkers, J., van Dijk, C., Voragen, A. G. J., and Recourt, K. 1997. Chemical and microscopic characterization of potato (*Solanum tuberosum* L.) cell walls during cooking. *J. Agric. Food Chem.*, **45(1)**:50–58.
- Voisey, P. W. 1970. Test cells for objective textural measurements. *Can. Inst. Food Technol. J.*, **3(3)**:93–102.
- Voisey, P. W. and Crete, R. 1973. A technique for establishing instrumental conditions for measuring food firmness to simulate consumer evaluations. *Journal of Texture Studies*, **4**:371–377.
- Voisey, P. W., Lyall, L. H., and Kloek, M. 1970. Tomato skin strength: Its measurement and relation to cracking. *J. Amer. Soc. Hort. Sci.*, **95(4)**:485–488.
- Wahem, I. A. 1988. The influence of the firmness of raw tomatoes on the physical, chemical and sensory characteristics of canned products. *J. Food Quality*, **11**:107–116.
- Wallner, S. J. and Bloom, H. L. 1977. Characteristics of tomato cell wall degradation *in vitro*. Implication for the study of fruit-softening enzymes. *Plant Physiol.*, **60**:207–210.
- Wallner, S. J. and Walker, J. E. 1975. Glycosidases in cell wall-degrading extracts of ripening tomato fruits. *Plant Physiol.*, **55**:94–98.
- Weaver, M. L., Huxsoll, C. C., and Ng, K. C. 1980. Sequential heat-cool peeling of tomatoes. *Food Technology*, 40–43.
- Whittenberger, R. T. and Nutting, G. C. 1957. Effect of tomato cell structures on consistency of tomato juice. *Food Technology*, **11**:19.
- Whittenberger, R. T. and Nutting, G. C. 1958. High viscosity of cell wall suspensions from tomato juice. *Food Technology*, **12**:420.
- Wolcott, T. K. 1982. Tomato product consistency. *Tomato Day*. University of California, Davis.
- Worthington, J. T., Massie, D. R., and Norris, K. H. 1973. Light transmission technique for predicting ripening time for intact green tomatoes. *ASAE pap.* 73–6526.
- Xu, S.-Y., Shoemaker, C. F., and Luh, B. S. 1986. Effect of break temperature on rheological properties and microstructure of tomato juices and pastes. *J. Food Sci.*, **51(2)**:399–402, 407.
- Zobel, M. B. 1966 (printed Dec. 1976). Mechanization of tomato production. *Processors National Conference on Tomatoes*, Dept. Horticulture, Purdue University, Lafayette, IN. National Food Processors Association.