

FORUM

San Francisco

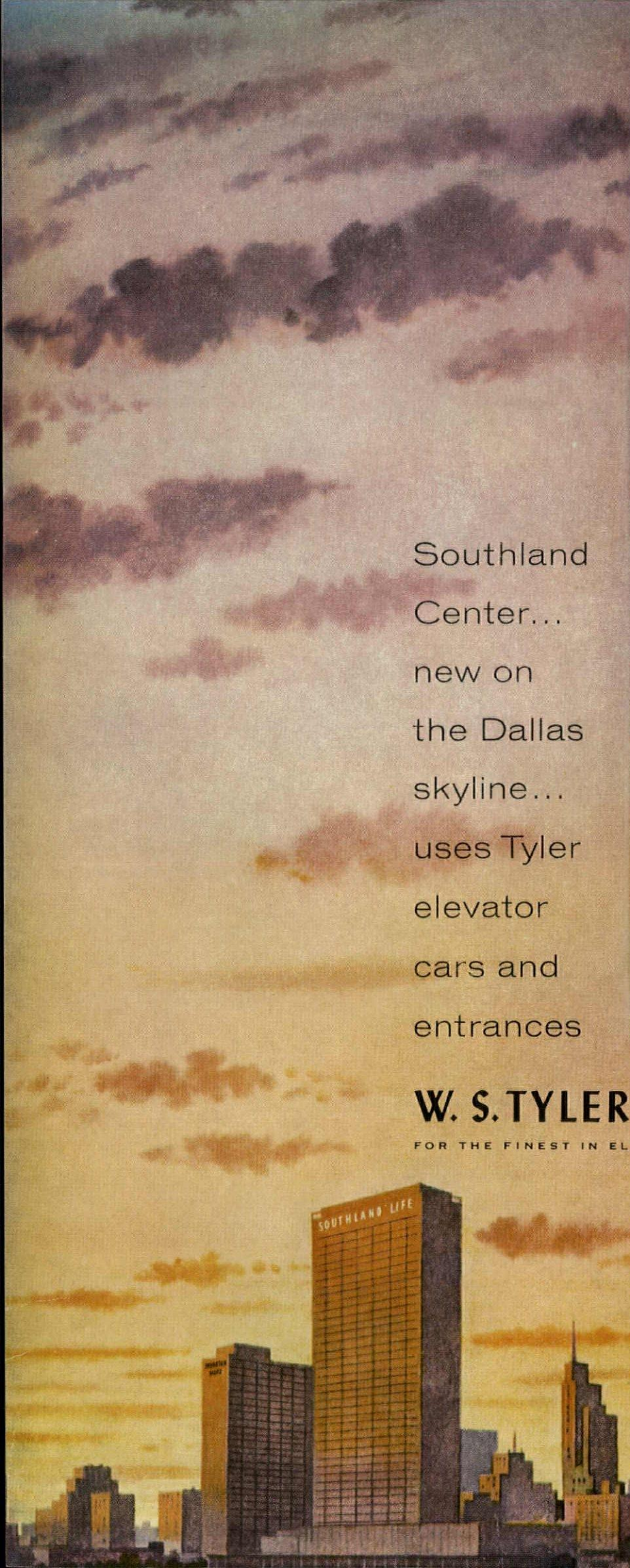

Southland
Center...
new on
the Dallas
skyline...
uses Tyler
elevator
cars and
entrances



Southland Life Tower and Sheraton Dallas Hotel, integral parts of Southland Center, Dallas • Architects and Engineers, Welton Becket and Associates • Elevators by Westinghouse. Owner, Southland Life Insurance Company

W. S. TYLER

FOR THE FINEST IN ELEVATOR CARS AND ENTRANCES



THE W. S. TYLER COMPANY
Cleveland, Ohio
OFFICES: NEW YORK • BOSTON
PHILADELPHIA • CHICAGO • ATLANTA
DALLAS • SAN FRANCISCO
LOS ANGELES • SALT LAKE CITY
THE W. S. TYLER COMPANY
of Canada, Ltd.
ST. CATHARINES, ONTARIO • BRANCH
OFFICES: MONTREAL • TORONTO

Library of the
Minneapolis School of Art

CITIES

San Francisco's changing cityscape 98

Although some of the old city's charm may have been sacrificed to the local building boom, planners and citizens are now coming to the rescue.

San Francisco's newest tower 104

As the western development of a Chicago style, S.O.M.'s John Hancock Building enriches the city's romantic architectural continuity—a criticism.

San Francisco's \$100 million contest 112

In the keenest urban renewal competition yet, the city will choose one of these nine projects for its Golden Gateway project.

ART OF ARCHITECTURE

A medal for Mies van der Rohe 132

This month the A.I.A. honors a pioneer of modern architecture who is still pioneering. His redevelopment of Lafayette Park in Detroit shows how.

Rooms for worship 140

From the office of Harold Spitznagel comes this trio of handsome interiors, each for a different denomination, all in Sioux Falls, S. D.

BUSINESS OF BUILDING

A.T.&T.'s architectural quest 120

Building's biggest client, cautiously seeking, has yet to find what message architecture might put into buildings for the wondrous telephone industry.

The client and the architect 123

Satirist Robert Osborn portrays a classic relationship—a gallery.

What next in shopping centers? 129

The economics have been changing—the stress now is on long-term, steady gains rather than quick, speculative profits.

The new rivals: architects and designers 138

Now that architects design carpets and industrial designers tackle architecture, building clients wonder who properly does what.

TECHNOLOGY

The problem of the sealed building 144

Obligatory air conditioning begets hostility unless it is specifically designed for particular kinds of space.

- 5 News
- 13 People
- 65 Projects
- 71 Products
- 95 Editorials
- 150 Ideas
- 155 Abroad
- 177 Excerpts
- 185 Books
- 251 Forum

Cover: Design by Ray Komai, based on San Francisco's John Hancock Building (story, page 104).

252 Editorial, subscription, and advertising data.

248 Advertising index.

Published monthly by TIME INC. Time & Life Building, Rockefeller Center, New York 20, N.Y. This issue is published in a national and western edition. Entered as second-class matter at New York, N.Y. and at additional mailing offices. Subscription price \$6.50 a year. © 1960 TIME INC. All rights reserved.

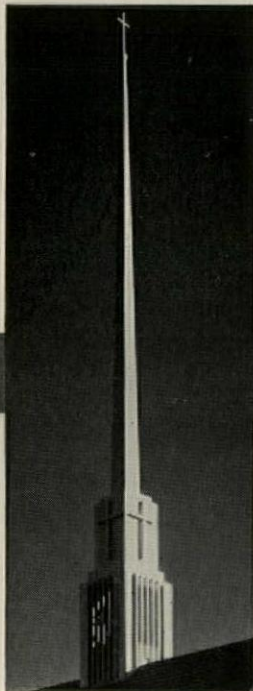
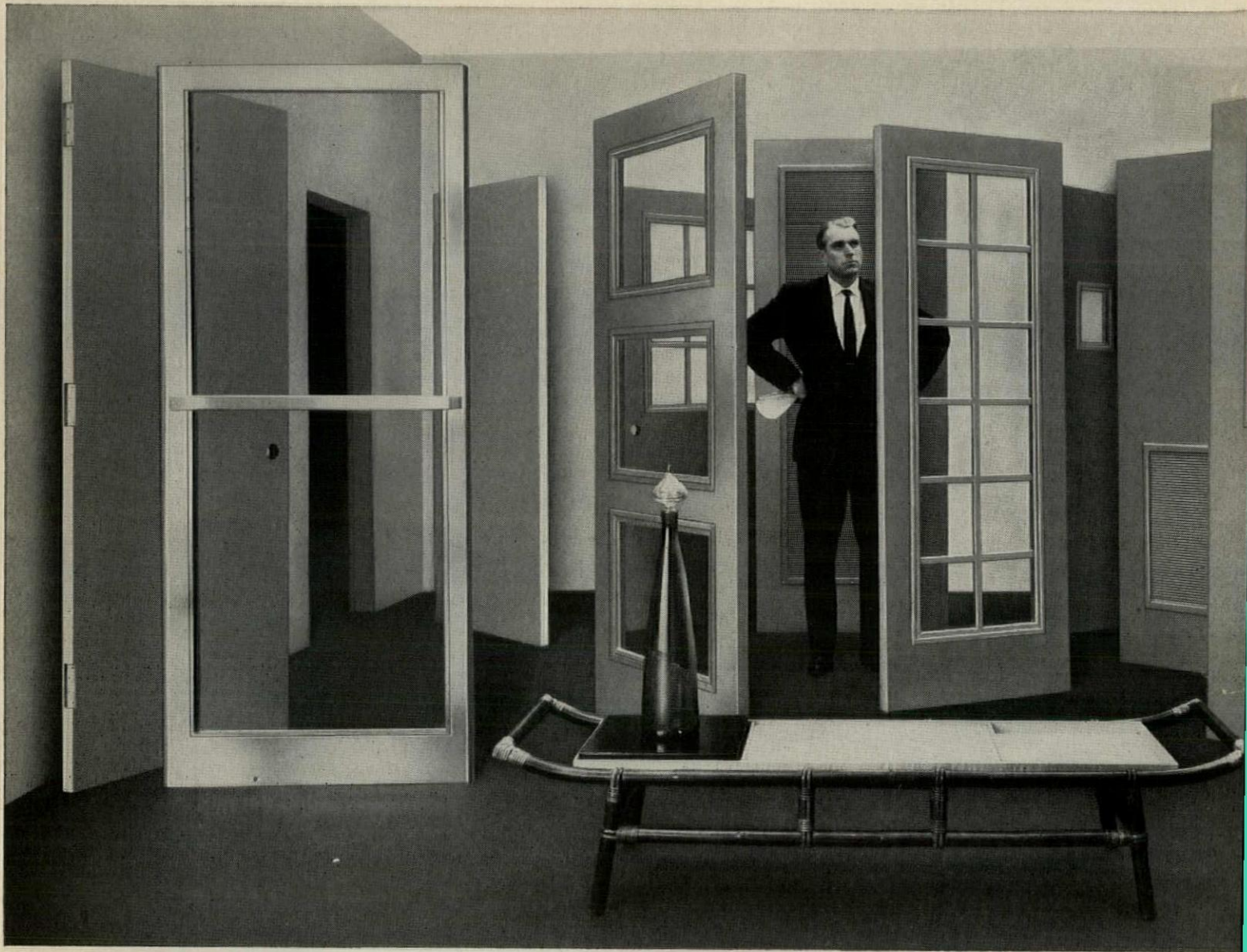

Overly Church Spires

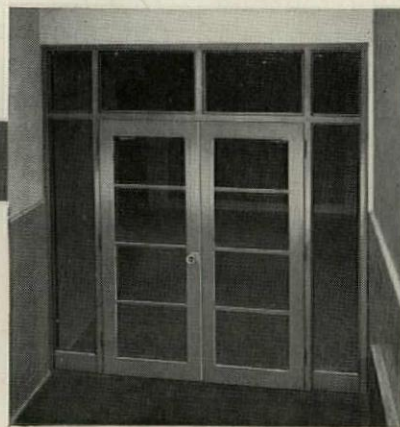

Overly U/L Labeled Fire Barriers

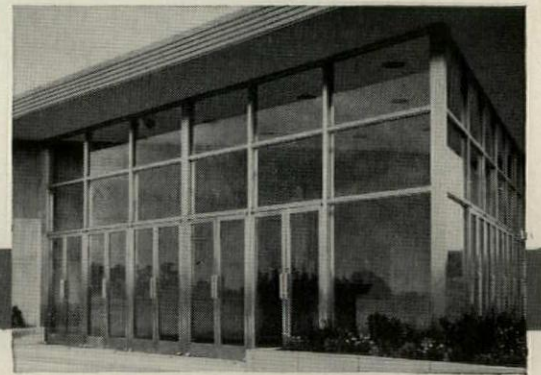

Overly Stainless Steel Entrances

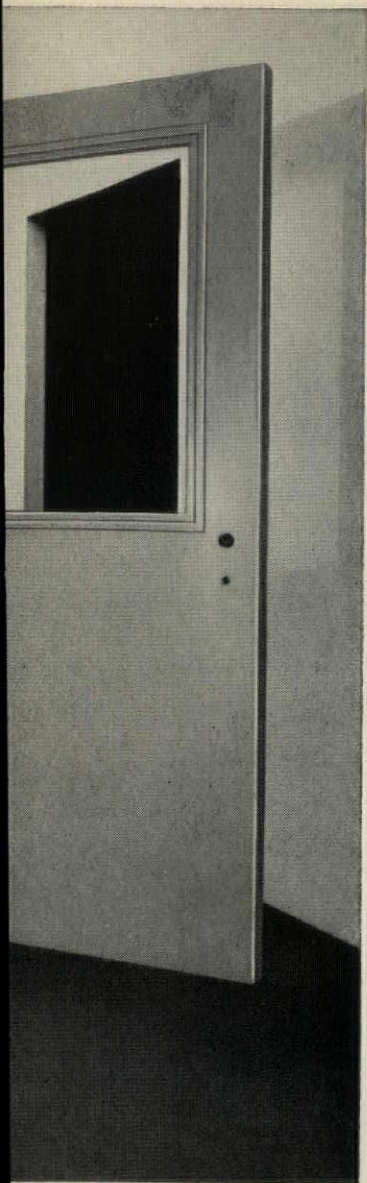

More design freedom with Overly Doors

Overly hollow metal doors and frames are crafted to complement any division of space, providing attractive and functional entrances and doorways. The architect has a choice of over 90 basic door styles, designed for every type of location and tailored to suit the installation.* Each door design is available in steel, stainless steel, bronze, aluminum or other metals, with prime, baked enamel, laminated fabric and hand-grained wood finishes. For every special installation, Overly custom doors are crafted to meet the most exacting architectural specifications.

The architect also has a complete line of Overly labeled doors for his selection. These doors have been tested by Underwriters' Laboratories, and in many instances, their performance records were in excess of the U/L standards. And the Overly Fire Barrier, only U/L tested and labeled Fire Barrier available today, is designed to protect corridors and stairwells in schools, institutions and public buildings.

Other Overly architectural products include Overline Stainless Steel Entrances, Overly Tilt-A-Front installations, Overly Goodwin batten-type roofs to match any shape or form, and Overly Church Spires rendered tastefully in modern or Gothic. Each of these products, and the new products to follow, will be subjected to the same sensitive scrutiny and exhaustive testing that have been part of Overly craftsmanship in the past. For your architectural metal needs, why not contact Overly?

**No other manufacturer catalogs so many different door designs. Among the recent installations using Overly doors are the Libbey-Owens-Ford Building, Toledo, Ohio; the H. K. Porter Building, Pittsburgh, Pa.; the Beverly-Hilton Hotel, Los Angeles, Calif.; the Kroger Building, Cincinnati, O.; the John J. Kane Hospital, Pittsburgh, Pa.; and the First National Bank Building, Fort Worth, Texas.*



Overly Goodwin Pre-fabricated Roofs

The Architect's Craftsman

Overly

MANUFACTURING COMPANY

Greensburg, Penna. • St. Louis 19, Missouri • Los Angeles 39, California

You pay no more for unequalled SLOAN quality...

Flush urinals Automatically

WITH THE **Sloan**
Flushing System

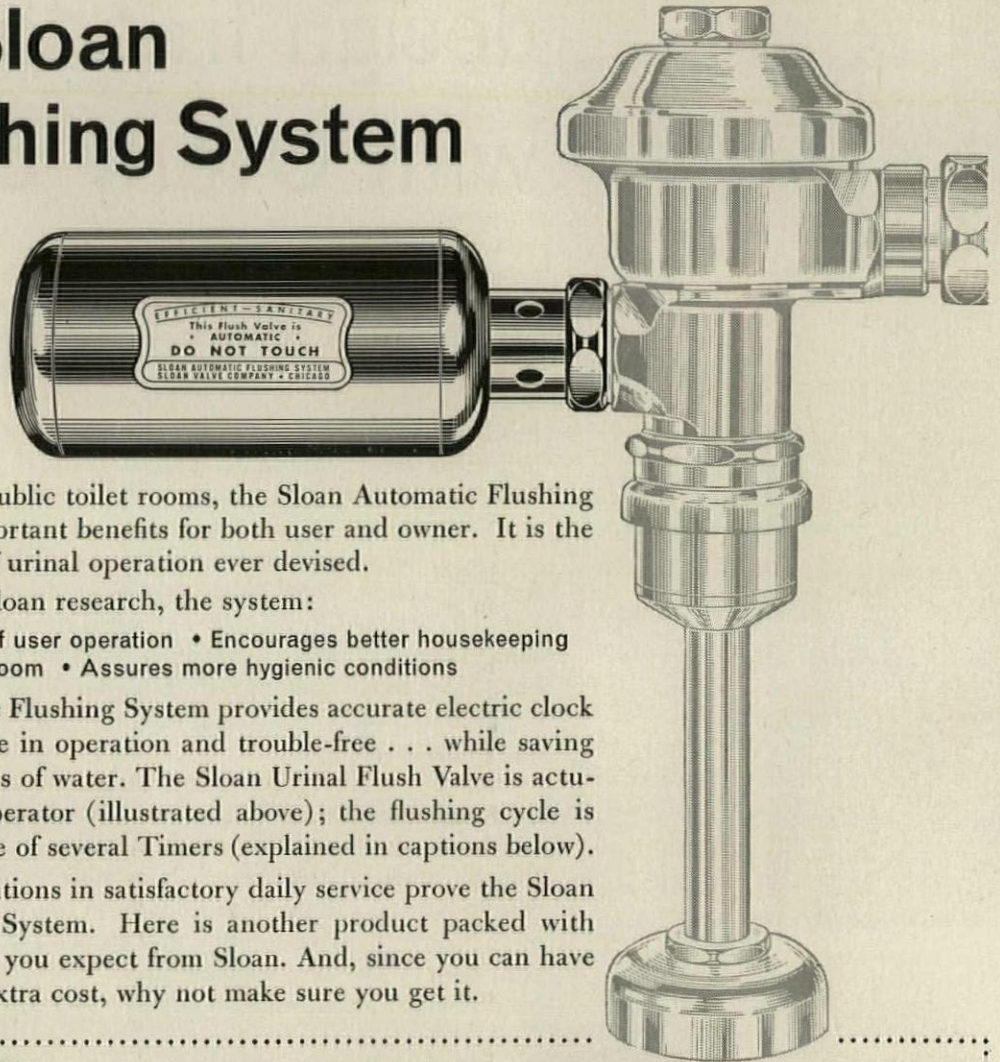

In public and semi-public toilet rooms, the Sloan Automatic Flushing System provides important benefits for both user and owner. It is the most ideal method of urinal operation ever devised.

Pioneered through Sloan research, the system:

- Eliminates the need of user operation
- Encourages better housekeeping of the toilet room
- Assures more hygienic conditions

The Sloan Automatic Flushing System provides accurate electric clock timing; is dependable in operation and trouble-free . . . while saving tremendous quantities of water. The Sloan Urinal Flush Valve is actuated by a Motor Operator (illustrated above); the flushing cycle is controlled by any one of several Timers (explained in captions below).

Thousands of installations in satisfactory daily service prove the Sloan Automatic Flushing System. Here is another product packed with that bonus of quality you expect from Sloan. And, since you can have Sloan quality at no extra cost, why not make sure you get it.



SINGLE CIRCUIT TIMER for flushing one Flush Valve (or two simultaneously).

THREE CIRCUIT TIMER for sequential flushing of three Flush Valves. Either one connected to light switch so that flushing occurs only when light is on and toilet room ready for use.

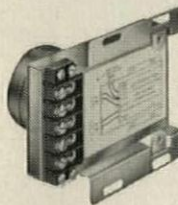

DOOR-OPERATED TIMER

employs door switch (not furnished) which starts Timer as user enters toilet room. Flushing occurs within succeeding five minutes while successive door openings have no effect.



DAY-NIGHT TIMER

for large number of Flush Valves. Controls urinal Flush Valves for each toilet room in sequence at five minute or one hour intervals according to traffic hours of the building.

SLOAN FLUSH VALVES



SLOAN VALVE COMPANY • 4300 WEST LAKE STREET • CHICAGO 24, ILLINOIS

Details announced for entering Franklin D. Roosevelt Memorial competition; any type project eligible

A national design competition for an appropriate memorial to Franklin D. Roosevelt in Washington on a 10-acre Tidal Basin site within the triangle of the Washington Monument and the Lincoln and Jefferson Memorials will be inaugurated this month.

Six winners in the four-month first stage of the competition will receive prizes of \$10,000 each, and be required to submit more detailed proposals. In this second stage, lasting three months, one of the contestants will win another \$50,000 prize, or the contract to draw the final plans and supervise construction of the memorial. The competition is restricted to registered architects who reside in the U.S. and to resident landscape architects, sculptors, or painters in association with registered architects.

The Franklin Delano Roosevelt Memorial Commission's advisory committee of seven architects, landscape architects, and city planners (Pietro Beluschi, chairman, plus Samuel Glaser, R. Sturgis Ingersoll, Lewis Mumford, G. Holmes Perkins, Hideo Sasaki, and Jay S. Unger) decided that it would not be "wise or appropriate" to designate a particular form for the memorial. Their reasoning: "It would stultify the mind of the designer, perhaps paralyze him. If the committee were to indicate beforehand whether the appropriate form would be a building, a garden, a fountain, a pool, a whole landscape, or all of these wrought together in some fresh, surprising, and appropriate form." However, for the guidance of contestants the commission cites a report it prepared in 1958, when it unanimously selected the site for the memorial: a peninsula between the Potomac and the Tidal Basin (see photo) that is now partially occupied by a number of barrack-type temporary government buildings that eventually will be demolished. Said this report:

"The Tidal Basin site . . . suggests a more reflective expression [than other sites that were considered] and, because of its location, a less dominant form than the Lincoln, Jefferson, and Washington Monuments. This need not mean that the design be of lesser quality. It will have its own quality, which should balance the other three and complete

them. . . . In drawing up a program for the Roosevelt Memorial therefore, it will be well to cast aside . . . any previous building or work of art, as a model to be directly imitated. . . . We must look rather to the character and work of Franklin Roosevelt to give us the theme of a memorial that will do him the honor he deserves and transmit his living image to future generations."

The commission's announcement on March 20, less than a month short of 15 years after Roosevelt's death in April 1945, allowed competitors five weeks to enroll in the competition. Says the commission: "No registration will be accepted after May 16; to be completely sure of receiving programs without delay, participants must register by April 25. It is anticipated that the competition will commence in early May upon the mailing of the competition program. The first stage will last four months and the second stage three months." Registration forms and programs are available from Edmund N. Bacon, professional adviser for the competition, Room 108, Tariff Commission Building, Washington 25, D. C.

The award jury will consist of Beluschi, chairman, plus Thomas D. Church, San Francisco landscape architect; Bartlett Hayes Jr., director of the Addison Gallery of American Art, Phillips Academy, Andover, Mass.; Joseph Hudnut, former dean of Harvard's School of Design, and Paul Rudolph, architect and chairman of Yale's School of Architecture. The jury may withhold any or all prizes if it should decide that submitted designs "are not of a sufficiently high standard of excellence."

If the ultimate winner contracts to
continued on page 6



Site for Franklin Roosevelt Memorial adjacent to the Washington Monument and Lincoln and Jefferson Memorials.

complete final designs and supervise construction of the memorial, his \$50,000 prize will be considered as an advance payment against gross fees of \$200,000 or greater; if gross fees are less than \$200,000, his prize money will be considered as a 25 per cent payment on such fees.

Political debates due on housing, renewal

Spring practice skirmishing in Washington last month left little doubt that housing and urban renewal will come in for considerable public debate once this year's Presidential election race gets under way in earnest.

An avowedly partisan report prepared by the Democratic Advisory Council's committee on urban and suburban problems, headed by noted redevelopment advocate Mayor Richard C. Lee, of New Haven, asserted that "each year more areas slip into slums than are cleaned up . . . in far too many cities today there are more slums than there were ten years ago. We can only conclude that the President and the Republican Party have turned their backs on cities and suburbs all across America. . . . Through government by veto, the President has repeatedly destroyed all Congressional efforts to fashion a comprehensive legislative program for urban renewal, depressed areas, and many other problem areas." A second paper by this committee, outlining its recommended solutions for urban and suburban problems, Mayor Lee reported,

will be issued later in the campaign.

The 29th annual convention of the National Housing Conference in Washington last month also heard numerous attacks on the administration's policy of reducing federal aid for public housing and urban redevelopment. One was a particularly acid comment by Senator John Sparkman (D, Ala.), chairman of the Senate subcommittee on housing, that some considered a distorted interpretation of Presidential remarks:

"No matter which party wins, I hope the next administration will improve upon the record made in the eight years following 1952. I am encouraged in this belief by the remarks made by the President reporting upon his visit to four South American countries: 'I was impressed, for example, by what I saw in Chile. I visited a low-cost housing project. The government had provided land and utilities. The home owners were helping one another build the new houses. They will pay for them monthly, over a period of years. Personal accomplishment brought pride to their eyes, self-reliance to their bearing. Their new homes are modest in size and character, but I cannot possibly describe the intense satisfaction they take in the knowledge that they themselves have brought about this great forward step in their living conditions.'

"How sad it is that the President did not discover the values of 'low-cost housing' in 1953—or even in 1959. But in any event, perhaps this attitude will persist and will influence the decisions of his successor in 1961 and future years. If another 'visit' should be necessary, I am sure the National Housing Conference could arrange visits to low-cost projects in [the U.S.]."

The NHC convention adopted a resolution favoring the creation of a full-fledged federal department for housing and urban renewal headed by a cabinet member. In this it was backed by Representative John V. Lindsay, a Republican often suggested as a Fusion candidate for mayor of New York against Tammany's heavily criticized Robert F. Wagner. Lindsay told the convention: "Urban centers are the cores of our national economy; if they are allowed to deteriorate any further, we will be eroding the very base of our existence. . . . We must accept the fact that federal assistance in the solution of metropolitan problems—urban problems—is both essential and wise. . . . The interests of both the local and state governments and the federal government would be more economically and efficiently served through the coordination in a single executive department of all federal activities concerned with urban affairs."

The new NHC president, succeeding William L. C. Wheaton, director of the Institute of Urban Studies at the University of Pennsylvania, will be Washington Redevelopment Consultant Nathaniel S. Keith, Truman administration director of the HHFA Division of Slum Clearance and Redevelopment, now the Urban Renewal Administration.

Volpe sees steady rise in building backlogs

Although the U.S. has set new construction outlay records almost every year since the end of the war, its production has been steadily falling behind in practically every type of new construction it needs. So declared one of the nation's ranking construction industry leaders in Washington last month in his keynote address opening the annual construction industry conference of the U.S. Chamber of Commerce.

John A. Volpe, president-elect of the Associated General Contractors of America, and former Public Works Commissioner of Massachusetts (where he is now a candidate for the Republican nomination for governor), predicted a rosy future for construction for many years to come, because, instead of diminishing, "the backlogs of needed community facilities are actually growing all the time."

Volpe first cited President Eisenhower's Economic Report to Congress in 1954, when the President said that to catch up on backlogs of community construction it would be necessary to spend \$8 billion annually for ten years for highways; \$6.75 billion annually for ten years for schools; \$1.8 billion annually for five years for water and sewer facilities, and \$1.5 billion annually for ten years for hospitals—a total of more than \$18 billion a year. "Today we know, better than we did six years ago," Volpe added, "that those estimates were conservative. Yet in no year since 1954 have we spent anything like as much as those estimates for a single one of these categories. And total expenditures for all four categories have run less than two-thirds as much annually as we thought we needed to spend six years ago. Last year they aggregated only \$11.4 billion, including both public and private outlays, as compared with the total of more than \$18 billion a year which the President said we needed to spend each year to catch up. . . . It is fair to say that substantially the same situation exists with respect to every other category of construction needs, public and private."

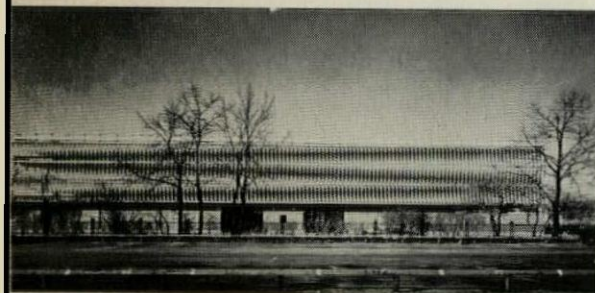

DETROIT GARAGE CITED FOR ARCHITECTURAL EXPRESSION IN CONCRETE

More than 1,700 pure white twisted concrete panels create the striking appearance of this four-story, 870-car park-it-yourself garage completed last November for Henry Ford Hospital, Detroit. Designed by Albert Kahn Associated Architects & Engineers, Inc., the structure cost \$3.70 per square foot. Use of such panels in this type of building is considered unique in America, and the building was commended for its architectural expression in an exhibition last month of parking structures held at the Institute of Civil Engineers, in London.

Mies and Breuer designs included in competing proposals for downtown Baltimore project

Elation was high in Baltimore last month when two fast-breaking developments presaged success for the city's bold and comprehensive Charles Center downtown redevelopment project (FORUM, June '58).

▶ Six rival developers, two Baltimore and four out-of-town firms, submitted competitive design proposals to build a store and office tower on the first parcel being offered in the area (see map and photos), and two of them offered premiums for the property above its minimum price.

▶ A week later, federal officials agreed to include a \$24.3 million federal office building in the project—largely because of the strong private interest in the area indicated by the competition for the office building parcel. The land price must still be settled, and an architect designated for the federal project. As the center's largest single building, with 550,000 to 600,000 square feet of

floor area, this will occupy a 2.3-acre block on the southern edge of the redevelopment, farthest from the central business district but suitably adjoining the proposed new civic center just west of Charles Center.

The six redevelopers who submitted proposals for the commercial property, a 31,438-square-foot plot covering the Charles Street blockfront between Lexington and Fayette Streets, estimated their construction costs in a range between \$9 and \$12 million, plus land costs. The prospectus for the sale of the property called for proposals for a 20- to 25-story office tower, with underground parking facilities, and with 250,000 to 275,000 square feet of floor area. On three sides, two- or three-story wings were to provide 30,000 to 40,000 square feet of store space. After review, the winning developer will be selected on the basis of 1) the total estimated costs for his project; 2) finan-

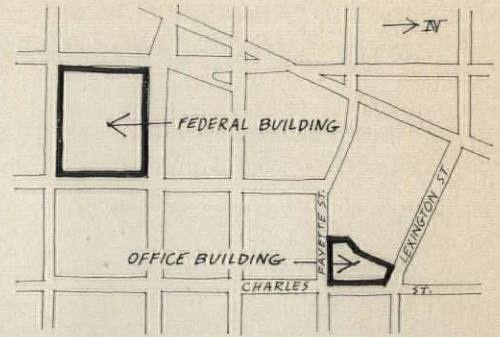

Seven-block area of Baltimore's Charles Center development shows sites for new federal building and first private office building.

cial responsibility; 3) how soon he is prepared to execute his project, and 4) the "architectural and design quality" he offers, including related landscaping. If two or more proposals are considered equally acceptable under these conditions, then the final selection will be made on the basis of land bids that exceed the \$800,000 minimum price.

The proposals received last month:

Metropolitan Structures, Inc., of Chicago.—A building designed by Mies van der Rohe that would cost an estimated \$12 million (the highest estimate in any of the proposals)—photo 1.

American Trading and Production Corp., of Baltimore, and McCloskey & Co., of Philadelphia.—A 26-story building designed by Marcel Breuer, estimated to cost at least \$10 million. This would have about 338,400 gross square feet of office space, 42,600 gross square feet of retail and commercial space, and 120 tenant parking spaces. This firm offered \$876,000 as an initial bid for the land (the highest offer at this stage)—photo 2.

Community Research and Development, Inc., of Baltimore.—A tower designed by Rogers, Taliaferro & Lamb. This firm is a subsidiary of the Baltimore mortgage and investment organization headed by James W. Rouse, president of ACTION (the American Council to Improve Our Neighborhoods) and a pioneer supporter of the Charles Center program and other Baltimore urban renewal efforts—photo 3.

E. J. Frankel Co., of Philadelphia.—This firm estimated that its proposed improvement, designed by John Hans Graham, would cost \$11.7 million (second highest estimated investment), and in its initial proposal it offered to pay at least \$825,000 for the land—photo 4.

Roscoe-Ajax Construction, Inc., of Washington.—A tower designed by Edwin Weihe—photo 5.

Bush Construction Co., of Norfolk,
continued on page 9

FRANK GARDINA

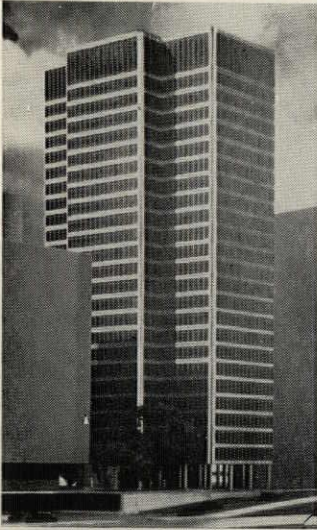

1



2

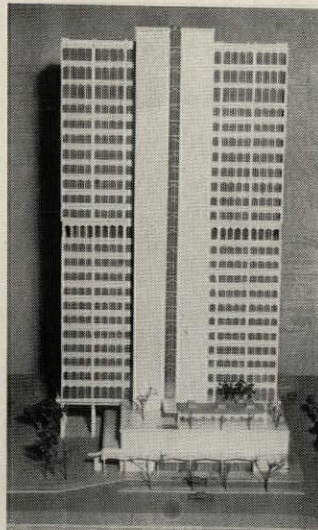

3

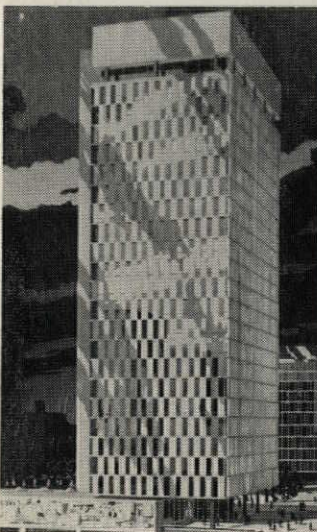

4

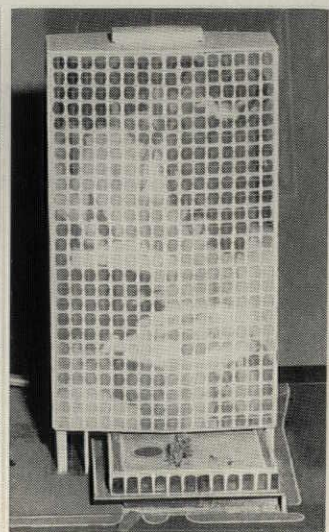

5

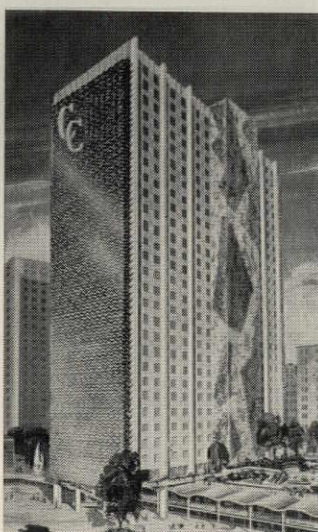

6

*Another of America's architectural achievements—
the Gulf Building—features **Briggs Beautyware***

Beauty, efficiency and durability are the most wanted features in the components of modern buildings.

For these reasons, Briggs Beautyware is being specified for more and more of America's fine buildings, typified by the Gulf Oil Company's building in Midland, Texas. Briggs offers the sculptured styling, lustrous durability and carefully worked out features so important in today's modern structures.

Put the advantages of Briggs Beautyware to work for you. Specify from the complete line of high-density vitreous china. Quality-controlled to meet every requirement, it will provide years of dependable operation. Briggs Beautyware is the brand that makes the difference. Send today for free literature. Advertising Department, Briggs Manufacturing Company, Warren, Mich.



GULF BUILDING—Midland, Texas. Owner: R. E. Dumas Milner, Jackson, Miss. Architects: Hedrick and Stanley, Fort Worth, Texas. Plumbing Contractor: Davis Plumbing Co., Jackson, Miss. Plumbing Distributor: Paine Supply Co., Gulfport, Miss.



BRIGGS CARLTON WATER CLOSET is a vitreous china syphon jet bowl available in six compatible colors, plus white.

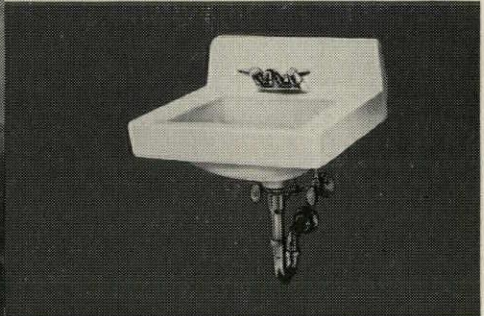

BRIGGS MILTON LAVATORY has 5" back, two cast-in soap depressions, anti-splash rim. Wall-mounted. Six compatible colors.



BRIGGS LAWTON URINAL is a wall-hung, washout urinal with integral extended shields, flushing rim, integral china strainer and trap with cleanout. Compatible colors or white.

BRIGGS
B E A U T Y W A R E

THE STYLE LEADER IN PLUMBING FIXTURES

Va.—A building designed by Charles F. McKirahan—photo 6.

Officials of Charles Center and of the Baltimore Urban Renewal and Housing Agency hope to complete their review of the six proposals and announce the winner by the end of this month, or name those who may be asked on a second round to bid against each other on the basis of land price. Final execution of a contract may be delayed, however, because city officials have now decided to try qualifying, under last year's federal housing act, for a federal Title I grant of approximately \$15 million for the Charles Center project. The project had previously won wide notice as an urban redevelopment scheme, asking no federal assistance.

In a somewhat similar competition, to be decided largely on planning and design, San Francisco received nine proposals for its large Golden Gateway project last month (story and photos on page 112).

Simplified URA rules may speed projects

Shorter and simpler regulations issued last month by the Urban Renewal Administration may trim as much as a year from the two to three years frequently needed to initiate renewal projects, if URA Commissioner David M. Walker has his way.

New federal urban renewal manuals that govern the activity of local renewal agencies have been slimmed about 40 per cent, from three volumes totaling 1,075 pages, to two volumes totaling 625 pages. In the process, according to Walker, many former requirements have been eliminated or simplified, and local agencies have been given much more of "the freedom and responsibility they want and should have."

In addition to greater local autonomy, says Walker, the speedier, simplified regulations are intended to attract to the program more redevelopers who have shunned it up to now because of its long and complicated procedures. To speed up projects as much as another eight to 12 months in some areas, Walker also has ordered an overhaul of processing procedures in URA headquarters and its seven regional offices. Coordinator for the recasting of the federal manual for local officials was William R. Ewald Jr., URA assistant commissioner for technical standards.

In a report on the availability of federal urban renewal funds, Walker said nearly \$220 million has already been allocated out of \$418.6 million of authorizations at URA's disposal since

start of the fiscal year last July 1. Grant reservation applications on hand total \$280 million, or roughly \$80 million in excess of available authorizations. Under the Housing Act of 1959, however, the agency will have another \$300 million of grant authority at its disposal beginning next July 1.

N.Y. housing study out; Moses ahead of it

When New York City's Title I slum clearance and redevelopment "scandals" were making daily headlines last August, Mayor Robert Wagner appointed a "special adviser" who was given a \$150,000 budget to make a fast sweeping survey of the city's multiplicity of housing, redevelopment, urban renewal and relocation programs, and to recommend a comprehensive correlated city policy and program in these fields.

Although the survey was not to be an "investigation" of Title I abuses, it served almost as well in causing a marked decrease in the volume and intensity of criticism of the city administration on this score pending completion of the survey, originally scheduled for February 1. In command of the survey

was J. Anthony Panuch, corporation and government agency reorganization specialist and former special adviser to General Lucius Clay, when the latter was head of the U.S. military government in Germany. Panuch also was long an admirer of the controversial Robert Moses, boss of the New York Title I program whom he respects highly as a benevolent-despot type of "bureaucrat" to be lauded for his ability "to get things done" in spite of all the governmental restrictions that usually circumscribe public officials.

Last month Panuch completed his survey, "well within the limits of the \$150,000 budget," but a month late because the mayor in the interim had requested him to expedite an extra, separate report on relocation problems.

Almost coincidentally, Moses announced that he was ready to give up his role as Title I boss, and some but not all of his other assorted city and state offices. The city's Slum Clearance Committee "has finished the job for which it was formed," organizing and getting a Title I program into execution, said Moses, and now others could carry it to completion. Simultaneously, Thomas J. Shanahan, vice chairman of the committee, who had been under fire

continued on page 10



MIES APARTMENTS NEARING COMPLETION IN NEWARK, NEW JERSEY

While Mies van der Rohe is in San Francisco this month receiving the A.I.A. Gold Medal (page 132), the first tenants will be completing arrangements to move into the three 22-story glass and aluminum apartment buildings he designed for two sections of a redevelopment project in Newark, N.J. The buildings are being erected by Metropolitan Structures, Inc., originally headed by the late Herbert S. Greenwald. Two of them (above) contain 340 apartments each, and

the third one about ten blocks away, 560 units. Within walking distance of downtown Newark, and about half an hour commuting time from midtown Manhattan, the buildings are being rented for \$96 for efficiency units, and \$134, \$179 and \$248 for one- to three-bedroom units. Last month more than one-half of the units in the first 340-unit building opening May 1 had been leased, and more than 70 of the units in the other two buildings scheduled for occupancy in June and in the early fall.

for mingling his banking activities with his official one, said he likewise would resign from the committee.

Moses' prospective severance from some of his several offices (at 71 he is past the city's regular retirement age and can only remain in office by periodic

special dispensation from the Board of Estimate), was coupled with an invitation for him to become president of the 1964 New York World's Fair, at a salary expected to be \$100,000 a year.

Although the Panuch report is oriented to New York's unique and complex housing and urban renewal problems, including a plan for a new Housing and Redevelopment Board that would consolidate the city's Title I operations with several of its other housing and renewal programs (but would exclude the City Housing Authority), it also contained a number of items of general interest:

▶ In another section, the report shows that New York City through last September 30 had been allowed 11.8 per cent of all Title I capital grant reservations in the entire country and had received 22.3 per cent of all disbursements. Disbursements for its own projects at that date equalled 32.1 per cent of the city's federal reservations.

▶ Indicative of the changing character of the city and its urban renewal problems, the report said that 875,000 more white people moved out of New York than moved into it between 1950 and 1957, and during the same period

293,000 more Negroes and Puerto Ricans moved in than moved out. This prompted Panuch to make two recommendations: 1) "The city must adopt new techniques to assimilate immigrants more effectively. This is not a matter of 'welfare.' It is a matter of economics and human relations." More specifically he urged that federal and state housing officials reverse their present policies and allow their subsidies to cover the expense of special programs to teach in-migrant public housing families the rudiments of "metropolitan city living" i.e., home sanitation and housekeeping. 2) New York Congressmen should seek legislation and action by HHFA and the Defense Department "to finance a massive program of slum clearance in Puerto Rico." Many Puerto Ricans move to New York to escape worse slum conditions there, so alleviation of conditions in Puerto Rico should lessen New York's immigration problem "and assist significantly the cause of inter-group relations in the U.S. and in New York."

▶ The report took note of FORUM's article last September on the city's Title I scandals (*The future of Title I*). "The writer," said Panuch's report,

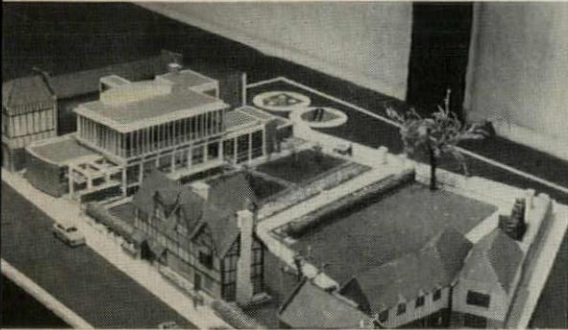

SHAKESPEARE GOES MODERN
AT STRATFORD

Scorning hoaxed-up traditional or fake period design, the Shakespeare Birthplace Trustees at England's Stratford-on-Avon announced recently that the new library and headquarters to be built next door to The Bard's home would be of modern design, in glass and concrete. Designed by Birmingham Architects Wood, Kendrick & Williams, the \$280,000 center will house the Birthplace Library and a collection of Shakespeariana from the Memorial Theater.

1950: 65 feet long . . . 1955: 125 feet long . . .

NOW: HAVEN-BUSCH T-CHORD* LONGSPAN JOISTS

- the longest steel joist made
- one-piece fabrication with matched-fit splices
- modern T-Chord* construction
- all web members designed for compression stresses
- ASTM-A-7 steel assures uniform factory quality
- minimum thickness of material $\frac{3}{16}$ " thickness
- highest standards — A.I.S.C. specifications
- every weld by certified AWS weldors

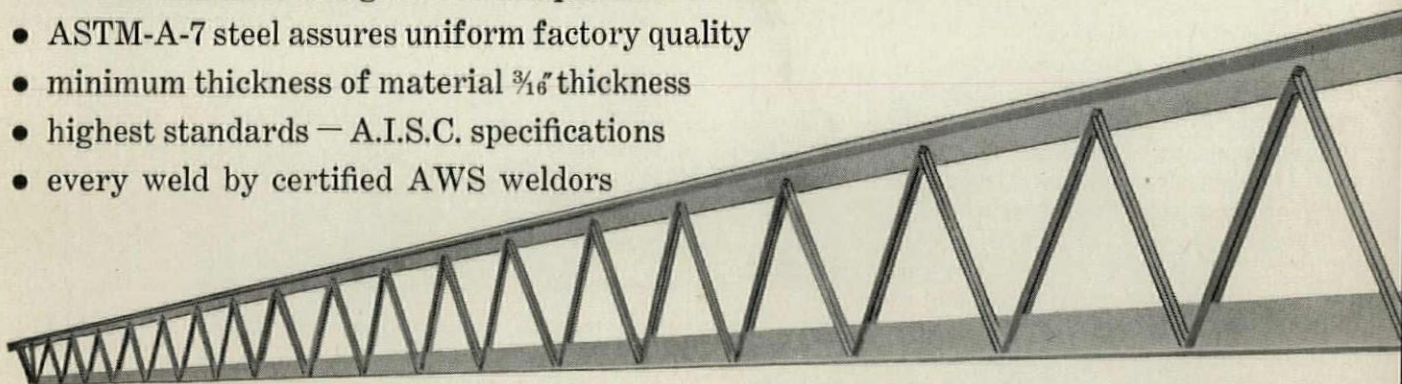

Opens new horizons for you in planning larger clearspan, column-free interiors.

*T.M. Reg.

"assumes that a meaningful 'coordinated plan' . . . and a 'consistent pattern' of urban redevelopment . . . for New York City, which does not even have a modern zoning ordinance, is feasible." Confining its comment on this article to a rhetorical question, the Panuch report said: "How does one evolve a 'consistent pattern' of urban redevelopment in a nontotalitarian society, in a city such as New York, where private builders and investors respond only to market opportunities?" But in those parts of his report which were not obvious appeasement, Panuch did outline a "consistent pattern" of proposals. Mayor Wagner had given him \$150,000 to do just that.

Brief

Ceremony outranked design when President Eisenhower laid the cornerstone for the U.S. Embassy in Brasilia during his South American good-will tour. When asked for a sketch of the building the State Department disclosed that no architect for the structure has been selected yet; the ceremony had been staged purely as a "symbolic" affair for the still-unconceived building.

Columbus and Genoa swap Columbus memorials

On Columbus Day, 1955, Columbus, Ohio unveiled in front of its City Hall a 20-foot, realistic 2½-ton bronze statue of Christopher Columbus by Italian Sculptor Edoardo Alfieri—a gift from the city of Genoa (left photo).

Last fall, two Ohio State University architecture students, Jean P. Gordon, 26, and George Enesey, 33, a refugee from the 1956 Hungarian uprising in Budapest, won a Columbus Area Chamber of Commerce design competition for a reciprocal gift to Genoa. Their design: three abstract symbolic 65- to 85-foot bronze masts and sails (representative of the *Santa Maria*, the *Pinta*, and the *Nina*) rising from an azure 60-foot diameter bowl, and an abstract island (representing the unknown sea and the erroneous maps of 1492). This was proposed as a centerpiece for a semicircular plaza on a promontory 100 feet above Genoa harbor (right photo).

The selection of the award jury, including Cleveland Architect Anthony S. Cirese and Cleveland Sculptor William McVey, caused considerable controversy



in Columbus, and some minor repercussions in Genoa. "Nothing but three flagpoles stuck in the ground," said Columbus Art School Dean Joseph Canzani. "An impressionistic monstrosity," complained another critic.

But in January, when a Columbus delegation including Architect Noverre Musson took sketches of the proposed memorial to Genoa, officials of that city accepted the gift offer with alacrity, the mayor of Genoa declaring that he was moved by "the deep meaning of the symbol." Back in Columbus, the Chamber of Commerce set out to raise the \$25,000 needed to have the memorial executed in time to dedicate October 12.

UP TO 175 FEET LONG!

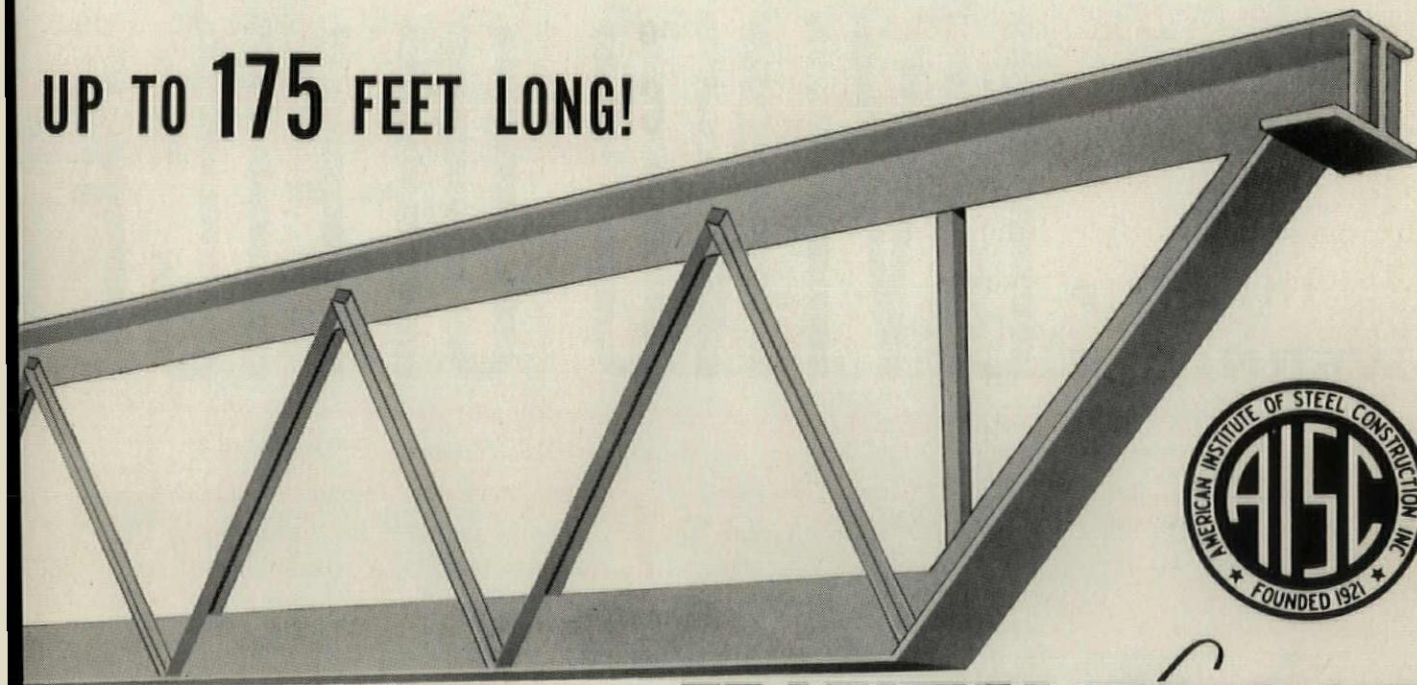

Better building begins with structural steel by

HAVEN-BUSCH
Company

3453 Chicago Drive, S.W., Grandville, Mich.

CHICAGO OFFICE: 228 N. LaSalle

DESIGNERS • FABRICATORS • ERECTORS

SINCE 1888

T-Chord* Longspan Joists — Structural Steel — Miscellaneous Iron



Write for illustrated brochure
with full technical data.

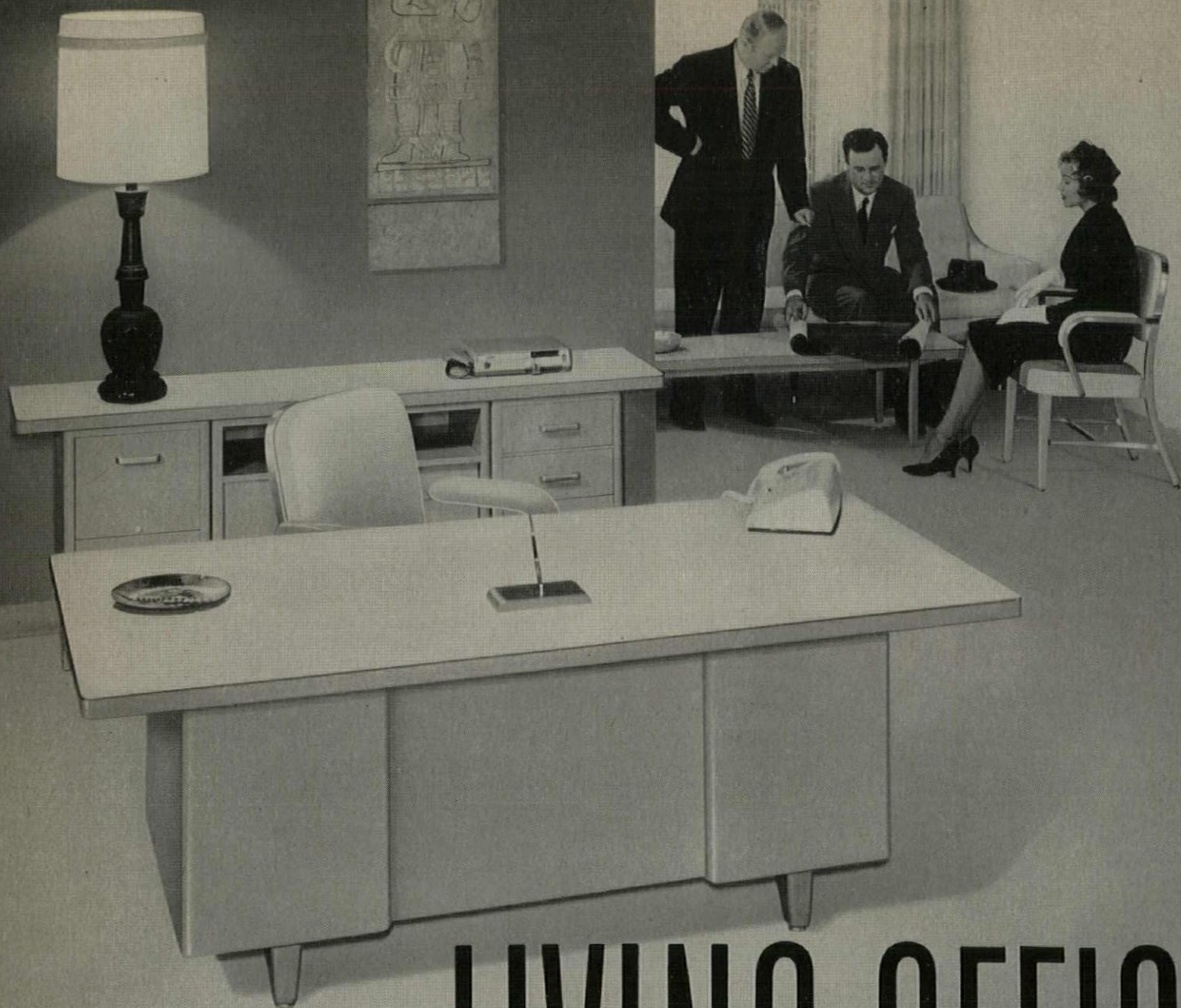

**this is a
GLOBE-WERNICKE**

LIVING OFFICE

Here is a brilliant new concept of the business office, planned for day-in, day-out comfort and efficiency. Just as furniture is designed for home living, Globe-Wernicke office furniture is designed for "business living." Your G/W dealer* will be happy

to show you how a custom-designed Streamliner "Living Office" can effectively lower your operating costs through increased efficiency. Call him soon, or write us direct for free booklet, Dept. V-4. *Dealers listed in Yellow Pages under "Office Furniture"



"C" PEDESTAL offers choice of 2 letter-size file drawers, 4 box drawers, or 2 box drawers and a file drawer. Same overall dimensions as other pedestals.



VERTI-SWING® or any hanging folders suspend directly from sides of Streamliner file drawer —no special or extra frame is needed.



VISIBLE RECORD CARD TRAY fits into desk arm slide, keeping facts at your fingertips. Holds 50 5" x 8" cards for 100 complete records.



THE GLOBE-WERNICKE CO.
CINCINNATI 12, OHIO

Globe-Wernicke makes business a pleasure

Architectural League exhibit, recast by Ketchum, regains prestige; Scheuer seeks Congress seat



CAMPBELL AND KETCHUM

"For nearly 80 years the Architectural League of New York has stood for the belief that architecture provides a framework for all the building arts, and that without these building arts no work of architecture is fully realized. The League's 61st national exhibition provides pictorial proof that the last five years of material prosperity in America have given our country's practitioners of the building arts the opportunity to create a new and brilliant renaissance in the art and science of building."

In appearance and demeanor easily mistaken for a contemporary university president, the speaker was Architect and League President **Morris Ketchum Jr.** The occasion was the opening of the League's 1960 National Gold Medal Exhibition of the Building Arts in the Museum of Contemporary Crafts of the American Craftsmen's Council, in New York.

Behind Ketchum's quiet, modest façade of precisely organized phrases, however, was another "brilliant renaissance"—of the show itself. It has been redesigned, mainly under Ketchum's impetus, to recapture the acclaim and importance of the famous League shows of about three decades ago—before their suspension, because of the famine in building and the decline of collaborative effort between architects and other artists, throughout some ten years of depression and war. Almost reverently, Ketchum recalls the League's spectacular shows that used to draw thousands to New York's old Grand Central Palace in the twenties.

To rebuild the quality of League shows, Ketchum established new "ground rules" and procedures. Among new measures: 1) a biennial instead of annual event, to allow better preparation and a broader base of outstanding works to choose from; 2) a carefully organized series of preliminary shows, in each of the different arts, from which final gold-medal contenders would be selected; 3) "inviting" selected architects and their collaborators to submit outstanding projects, and guaranteeing that any such entry would be shown in at least the preliminary exhibitions; 4) consideration of open submissions also; 5) limitation of entries to those that represent at least three of the building arts, including architecture, and have been completed within the previous five years; 6) the submission of entries mounted on standard panels, suitable for repeated easy packing as a

part of a traveling exhibition. Public interest was stimulated through an alliance with the American Craftsmen's Council headed by **David R. Campbell** and the American Federation of Arts, **Roy R. Neuberger**, president; the one providing a good local showplace and the other arranging a two-year circulating tour of the show beginning in September (and already booked for most of this period).

Another Ketchum innovation is a Collaborative Medal of Honor, for the project that best exemplifies outstanding collaboration among at least four of the building arts, including architecture. He stresses that this helps to demonstrate that the League—unlike the A.I.A. in its annual architectural Honor Awards program—honors achievement in all the building arts, including engineering, mural decoration, sculpture, landscape architecture, design, and craftsmanship. The 62 projects in the League's current show, he points out, honor not only 65 architects, but equally 89 engineers, 13 muralists, 21 sculptors, 23 landscape architects, and 25 designers and craftsmen. Incidentally, the show hung 57 out of 199 "invited" submissions from 111 artists, and seven out of more than 50 open submissions that were received. (One of the latter captured the design and craftsmanship gold medal.) Thirty-three League members are represented in the final show.

This year's gold medal winners:

Architecture—**Ludwig Mies van der Rohe** and **Philip Johnson**, for the Seagram Building.

Engineering—**Isadore Thompson**, for structural engineering of the Vista Mar Elementary School, Daly City, Calif.

Sculpture—**Alexander Calder**, for a mobile for the UNESCO Headquarters Building, Paris.

Landscape architecture—awarded jointly to **Skidmore, Owings & Merrill**, architects and landscape architects, and **Isamu Noguchi**, sculptor and landscape designer, for landscape design for the Connecticut General Life Insurance Building, Hartford, Conn.

Design and craftsmanship—**Hervey Parke Clark** and **John F. Beuttler**, architects, for building craftsmanship in Christ Church, Episcopal, Portola Valley, Calif.

Collaborative Medal of Honor—**Mario J. Ciampi** and **Paul W. Reiter**, architect and associate, and their collaborating structural and mechanical engineers, landscape archi-



An important new concept in building construction! Shlagro's new Vertical Member longspan joist is the first to provide a diagonal-free ceiling thru-way! The result: easier installation and maintenance of ducts, piping, wiring, sprinkler systems—all utilities. Future utility additions and emergency repairs are made without disturbing ceiling area. Meets all structural requirements for materials, strength, safety, design and stress—surpasses the older diagonal-type longspan joists in economy, appearance, and usable utility space. Write today for Shlagro Catalog 375.

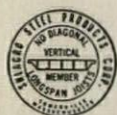

another PRODUCT by the PIONEERS of SQUARE columns!

SHLAGRO
STEEL PRODUCTS CORPORATION
SOMERVILLE, MASS.

I am interested in Shlagro No-Diagonal Longspan Joists and other SHLAGRO products checked below:

- #375 — SHLAGRO NO-DIAGONAL LONGSPAN JOISTS
- #100 — STOCK STEEL ROOF TRUSSES
- #150 — STOCK STEEL LONGSPAN JOISTS
- #200 — SQUARE STEEL COLUMNS
- #225 — KARRI-MORE SQUARE COLUMNS
- #230 — SHLAGRO SHEAR HEADS
- #300 — STOCK STEEL TURNABLES
- #350 — SCAFFOLDING
- #400 — EGG-SHELL STEEL PLATE ROOFS
- #450 — SHLAGRO DOME STRUCTURES
- #500 — STOCK STEEL RIGID FRAMES
- #550 — STOCK STEEL VERTICAL MEMBER TRUSSES
- #600 — STEEL VERTICAL LIFT DOORS
- #650 — NO SHELL PRE-CAST FIREPROOF REINFORCED CONCRETE COLUMNS
- #700 — STEEL FLOORSPAN GIRDERS
- #735 — SHLAGRO TRIANGULAR GIRDER
- #750 — STEEL WELDED PIPE TRUSSES
- #775 — KARRI-MORE BEAM AND GIRDER
- #800 — STOCK STEEL MOMENT CONTOUR BEAM AND GIRDER
- #825 — SHLAGRO TAPERED GIRDER
- #850 — PREFAB BUILDINGS FLAT ROOF
- #875 — PREFAB BUILDINGS PITCH ROOF

name _____
title _____

Please attach to your professional letterhead and mail to:
SHLAGRO STEEL PRODUCTS CORP.
SOMERVILLE, MASS.

teet, muralist and sculptor, for design and construction of Westmoor High School, Daly City, Calif.

THE TIME FOR ALL GOOD MEN

The nation may gain a new congressman but lose a redeveloper, if New York Builder **James H. Scheuer** wins the Democratic nomination in Manhattan's 20th Congress District in the primary election in June. Last month, 40-year-old politically ambitious Scheuer announced his insurgent candidacy for the nomination against incumbent Representative Ludwig Teller. Scheuer criticized his opponent as "a patronage-dispensing old-line Tammany district leader" and charged that he had one of the worst absentee records in Congress. The advancement of constructive and liberal legislative programs, said Scheuer, "demands the hard, unremitting work of a full-time congressman." If he should win the nomination and be elected, Scheuer



SCHEUER

agreed, he would no longer be able to devote any substantial amount of his time to his building and redevelopment interest. However, his redevelopment staff, headed since last June by **H. Ralph Taylor**, former executive director of the New Haven Redevelopment Agency, would be able to carry on effectively without him.

Meanwhile, **Roger L. Stevens**, partner with Scheuer in the Capitol Park Apartments project in Washington, and promoter of other realty, redevelopment, and theater interests, was chosen for the star role in raising funds for the Democratic National Committee, as chairman of its finance committee. In 1952 Stevens headed the finance committee for Volunteers for Stevenson, and in 1956 was named chairman of the official party finance committee. At the end of this year's repeat performance he hopes to exit with greater success than from the 1956 show, which closed with a deficit of \$800,000 and a Republican in the White House.

THEATER DESIGN GRANTS

Under a program to cost approximately \$150,000, the Ford Foundation has made
continued on page 16

MODERN
CONTEMPORARY
TRADITIONAL

Standard or
Custom to your design

**SKELETON
DIAL
CLOCKS**
by
ELTIME CO

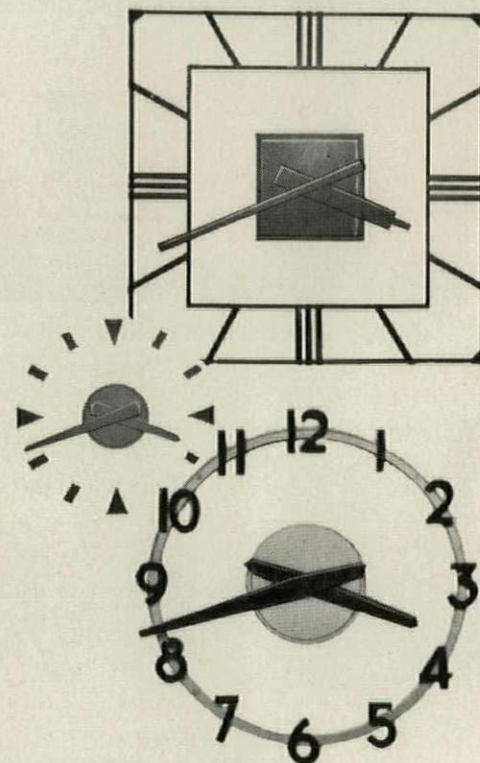

Indoor and outdoor types, guaranteed accuracy, use 110 v. current, multiple face mountings and remote control available, "Telechron" self-starting motors.



BULLETIN AIA-31-I-23 describing standard and custom ELTIME CO Skeleton Dial Clocks will be mailed upon request.

ELTIME CO

**ELECTRIC TIME
COMPANY, INC.**
17 Union Street
NATICK, MASS.

New York Office
51 East 42nd Street
New York 17, N. Y.

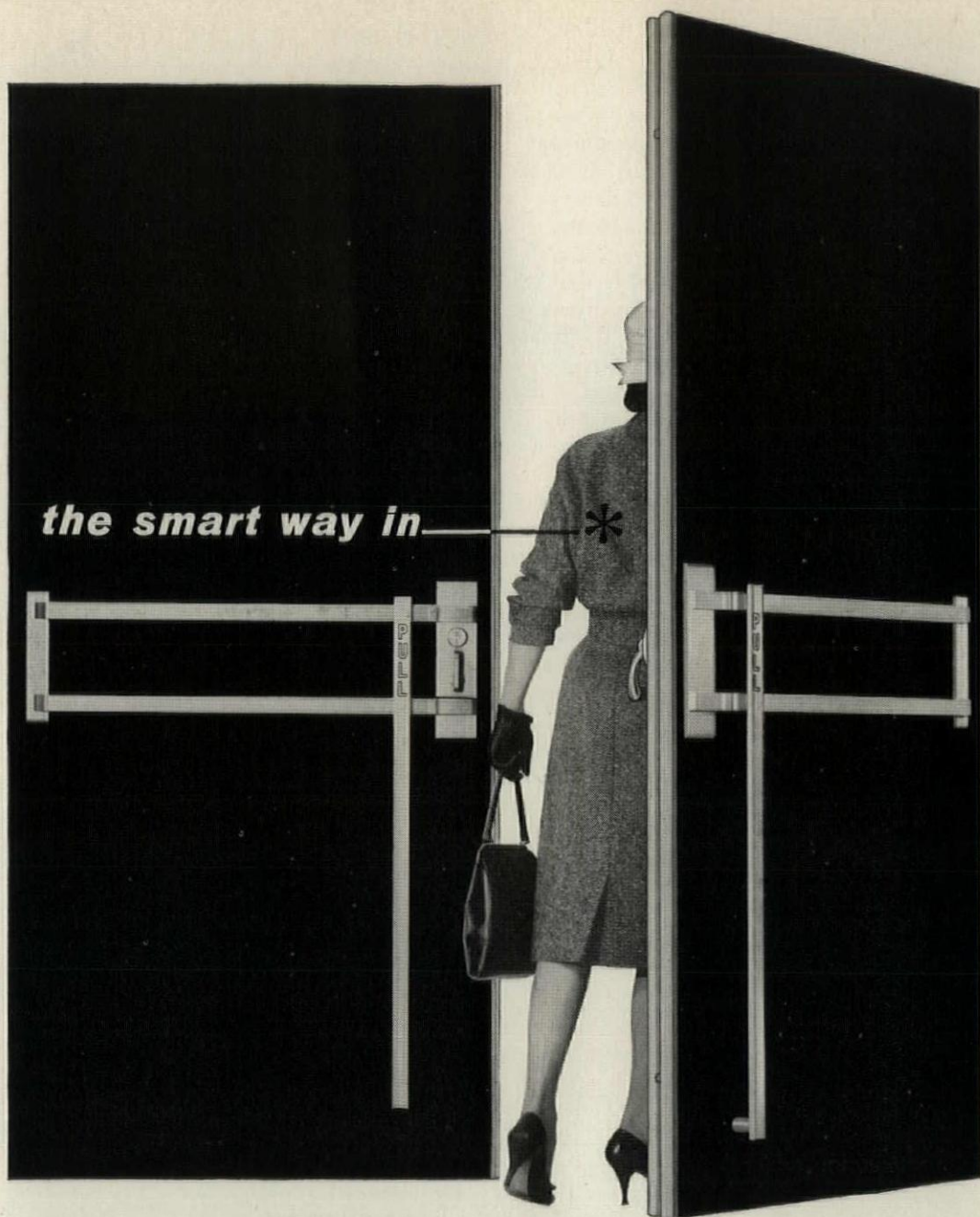

Von Duprin® PULL BARS

● Von Duprin pull bars are *all* extruded aluminum or bronze. Here is a fully versatile line: reversible . . . no resizing necessary . . . modern or matching designs, each with studs to anchor A² or 88 Von Duprin rim devices . . . plain or engraved grips are curved to fit the hand—safely. Matching push plates and pulls available for vestibule doors. Complete details are yours for the asking; write for Bulletin 576.

illustrated above: all extruded aluminum modern design with extended and engraved grips. Catalog number E282-ENG. on active door; E282DT-ENG. on inactive door.



VONNEGUT HARDWARE CO. • VON DUPRIN DIVISION • INDIANAPOLIS, INDIANA

TEMPRITE WATER COOLERS SERVE PRUDENTIAL

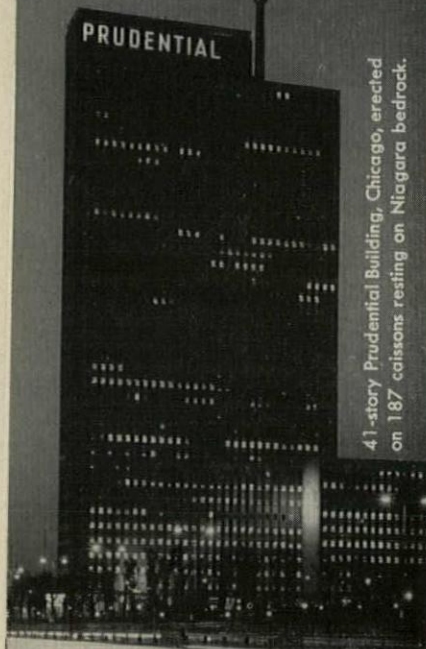

41-story Prudential Building, Chicago, erected on 187 coissons resting on Niagara bedrock.

Comparative analyses have led The Prudential Insurance Company of America and many other financial, commercial and industrial enterprises to select Temprite Drinking Water Coolers.

Reason? A clear-cut edge in quality...a clean-cut edge in styling.

Consult Sweet's Architectural file or clip coupon for details.

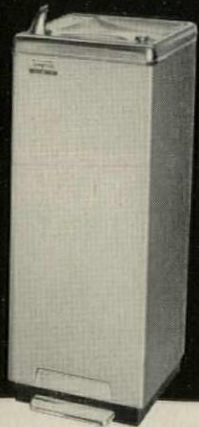

TEMPRITE PRODUCTS CORPORATION
P.O. Box 72K, E. Maple Rd., Birmingham, Mich. h.
Send me literature on Temprite self-contained water-coolers.

Company _____
Name _____
Address _____
City _____ Zone _____ State _____

grants to eight architect and theater designer teams to develop contemporary "ideal theaters" through design and model stages. The teams and their projects:

Paul Rudolph and Designer **Ralph Alswang**—a theater for new film-projection techniques and live stage action simultaneously.

Edward Durell Stone and Designer **Eldon Elder**—a 2,000-seat outdoor theater.

Paul Schweikher and Designer-Engineer **George C. Izenour**—a theater complex comprising one theater convertible among proscenium, Elizabethan, and arena-stage forms, and an experimental space controlled by an analogue and digital computer.

Peter Blake and Designer **David Hays**—a 299-seat open-stage theater.

Edward L. Barnes and Designer **Jo Mielziner**—a theater for intimate music-drama outside the traditional operatic and musical-comedy forms.

Seth Hiller and Designer **Barrie Greenbie**—a theater for modern dance.

Architect-Designer **Frederick J. Kiesler**, working with playwrights and mechanical engineers—a flexible urban theater adaptable to both classical and experimental plays.

Ben Schlanger and Designer **Donald Oenslager**—studies and design of proscenium theater form and space concepts, and of nonproscenium techniques for producing a maximum number of desirable viewing positions.

ARCHITECTS IN THE FINE ARTS

Fourteen architect members of the National Academy of Design were exhibitors in the Academy's 135th annual exhibition last month including **Edward Durell Stone**, who was awarded the Samuel Finley Breese Morse Medal for Architecture for his New Delhi Embassy and the Stuart Co. building, in Pasadena, Calif. Two of the other architect exhibitors were Philadelphian **John F. Harbeson**, recently elected for his second term as president of the Academy, and Associate Member **Hugh Ferriss**, of New York, who simultaneously was elected a full member of the Academy.

Two architects, **Wallace K. Harrison** and **Gordon Bunshaft**, of New York, and **Alexander Calder**, of mobile-sculpture fame, were among the 12 new members elected to the National Institute of Arts and Letters last month, when it also installed **Pietro Belluschi** as one of its new vice presidents.

In Los Angeles, Architect **William L. Pereira** was elected as the new board chairman of the Los Angeles County Art Institute.

END



NEW STRAN- WALL SYSTEM

FRAMING DETAILS

Lightweight, load-bearing, nailable steel framing can be delivered in lengths pre-cut for the job, and handled without the aid of machinery. Windows, available in a variety of designs, slip in place quickly. Panels are hung from the integral "j" girts and simply snap in place without exposed fastenings—without welding, riveting or mispositioning.

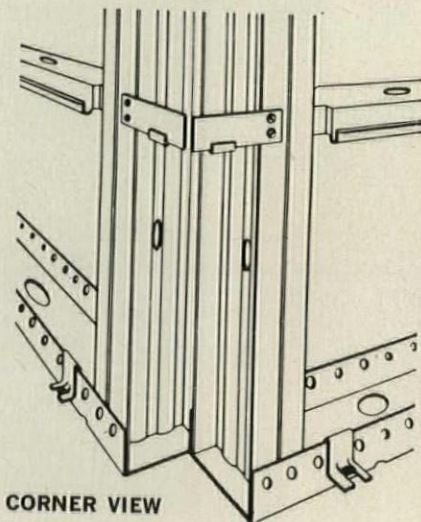

CORNER VIEW

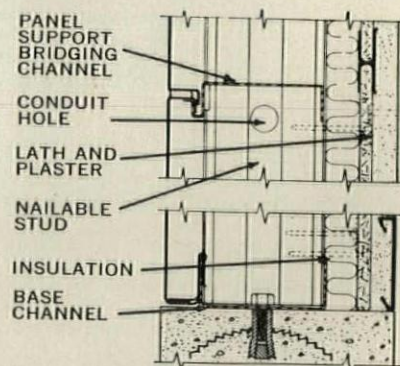

WALL CROSS SECTION



IT'S REVOLUTIONARY! IT'S LOAD-BEARING! IT'S ONE-POINT RESPONSIBILITY!

Here's a complete modular wall system which integrates lightweight nailable steel framing with architectural porcelain panels and aluminum extrusions. The steel framework is load-bearing and specially designed to hold the thermally efficient panels without additional framing or attachment operations. This skeleton-and-skin coordination not only saves during construction, it provides unlimited design possibilities. ■ Foundations or footings need not be heavy or complex. The structural load-bearing framework of Stran-Steel has a high strength/weight ratio. Architectural panels and other collateral materials work without secondary members. And the integrated fit of joists and beams eliminates the need for dropped ceilings or boxed beams. ■ The complete Stran-Wall system—including panels, insulation, nailable steel framing, and aluminum Mullions for doors and windows—is available from one source, your Stran-Steel architectural products dealer. For specifications and details, mail the coupon or call him. He's listed in the Yellow Pages under Steel.

NEW STRAN-WALL SYSTEM

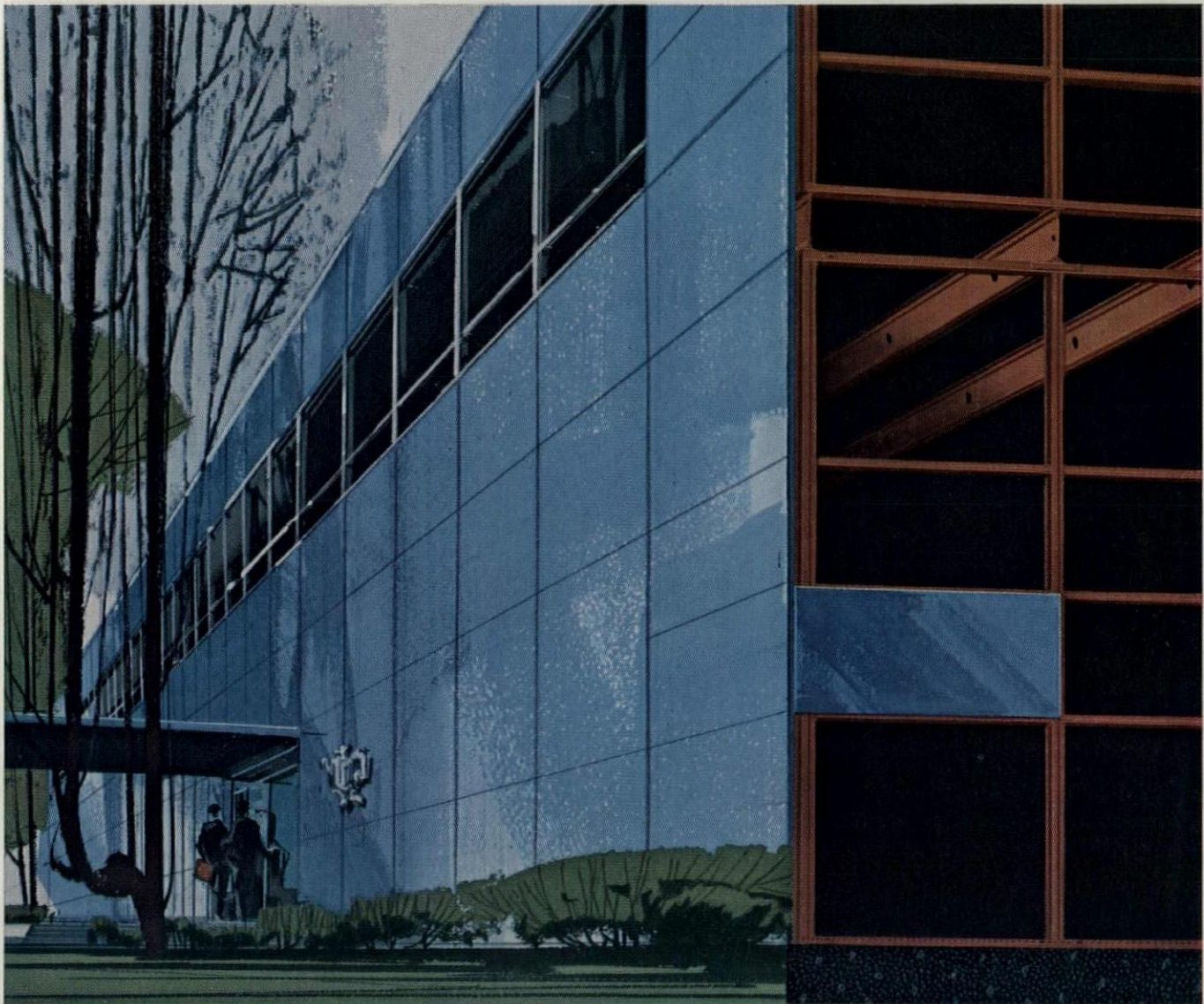

ARCHITECTURAL PORCELAIN PANELS: FLAT, COLORFUL, MAINTENANCE-FREE—Extremely flat panel surfaces reduce reflection patterns. Porcelainized both sides, Stran-Wall panels (shown below) come in 72 colors, 3 textures (smooth, ripple, stipple), 3 finishes (gloss, semi-gloss, matte).



Stran-Steel Corporation, Dept. AF-11, Detroit 29, Michigan

Please send complete information on the new Stran-Wall System.

Name _____ Title _____

Company _____

Phone _____

Address _____

City _____ Zone _____ State _____

STRAN-STEEL IS A DIVISION OF **NATIONAL STEEL CORPORATION**

Sealants based on THIOKOL liquid polysulfide polymer

Architecture

By bringing together the textures, colors, patterns available in modern structural materials, architects are changing the "look and feel" of urban centers . . . shaping buildings more beneficial to owners, occupants and the community at large.

This freedom of architectural design has grown with development of polysulfide sealants. Their unique sealing qualities . . . multi-material adhesion, long-life bonding, sympathetic expansion and contraction, shock absorption, high resistance to all deleterious elements, custom fitting to the job on the job, wide range of colors . . . have made polysulfide sealants integral to an expanding "architecture."



STAINLESS STEEL

STONE

ALUMINUM

BRONZE

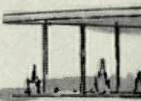

have helped open new worlds of building design...

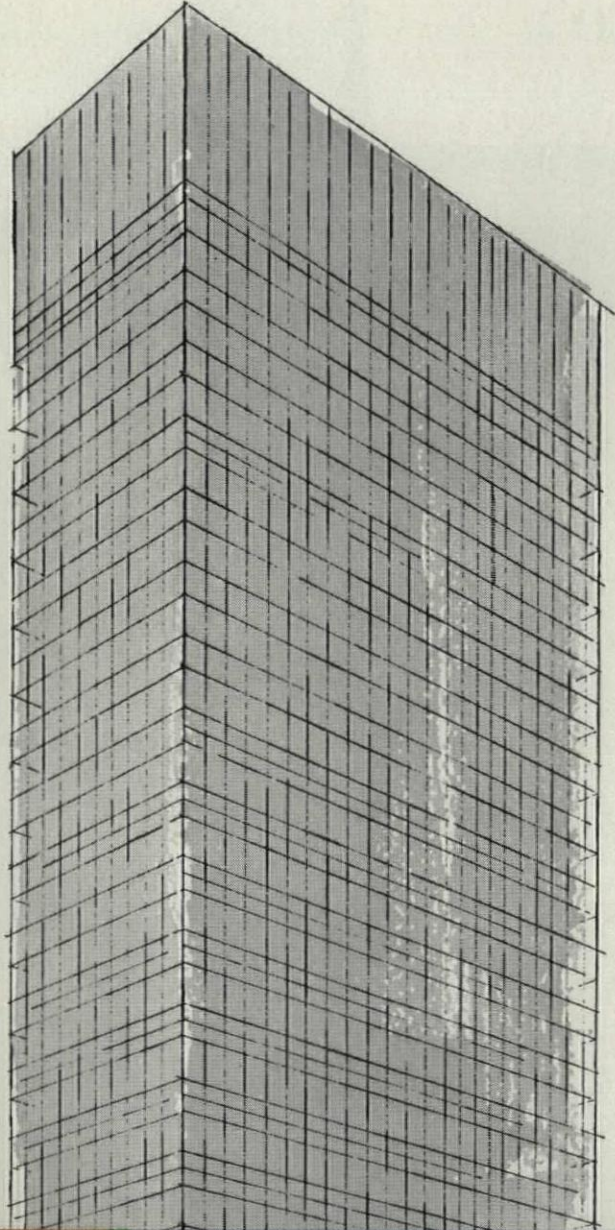

For further information, write:

Thiokol®

CHEMICAL CORPORATION

780 North Clinton Ave., Trenton 7, New Jersey

In Canada: Naugatuck Chemicals Division,
Dominion Rubber Co., Elmira, Ontario

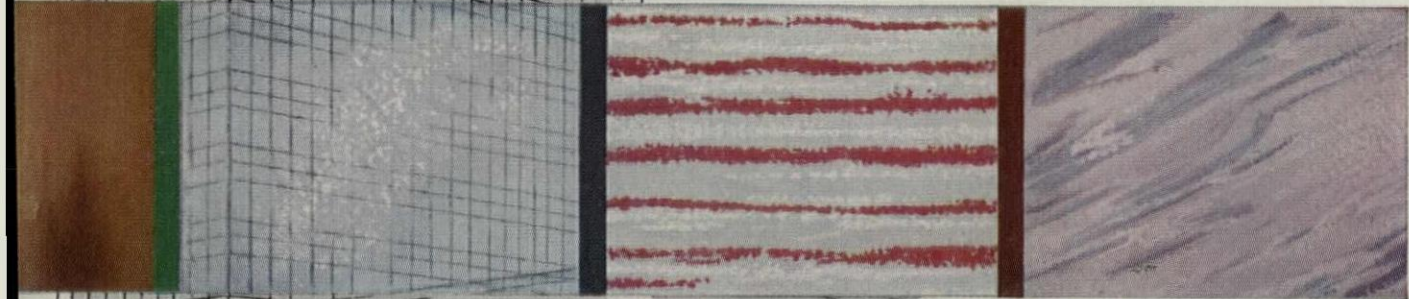

GLASS

PORCELAIN ENAMEL

MARBLE

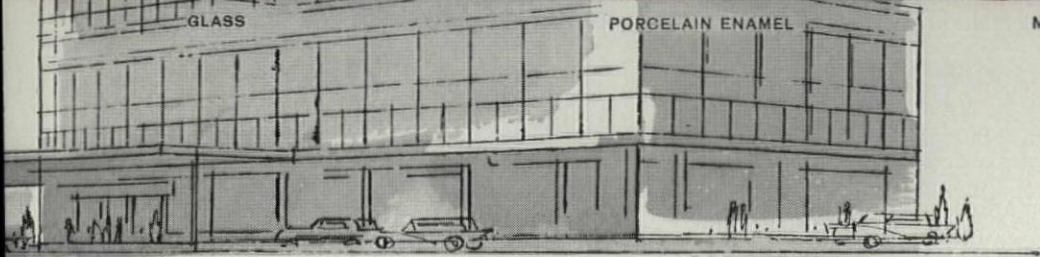

The best ideas are more exciting
in **concrete**

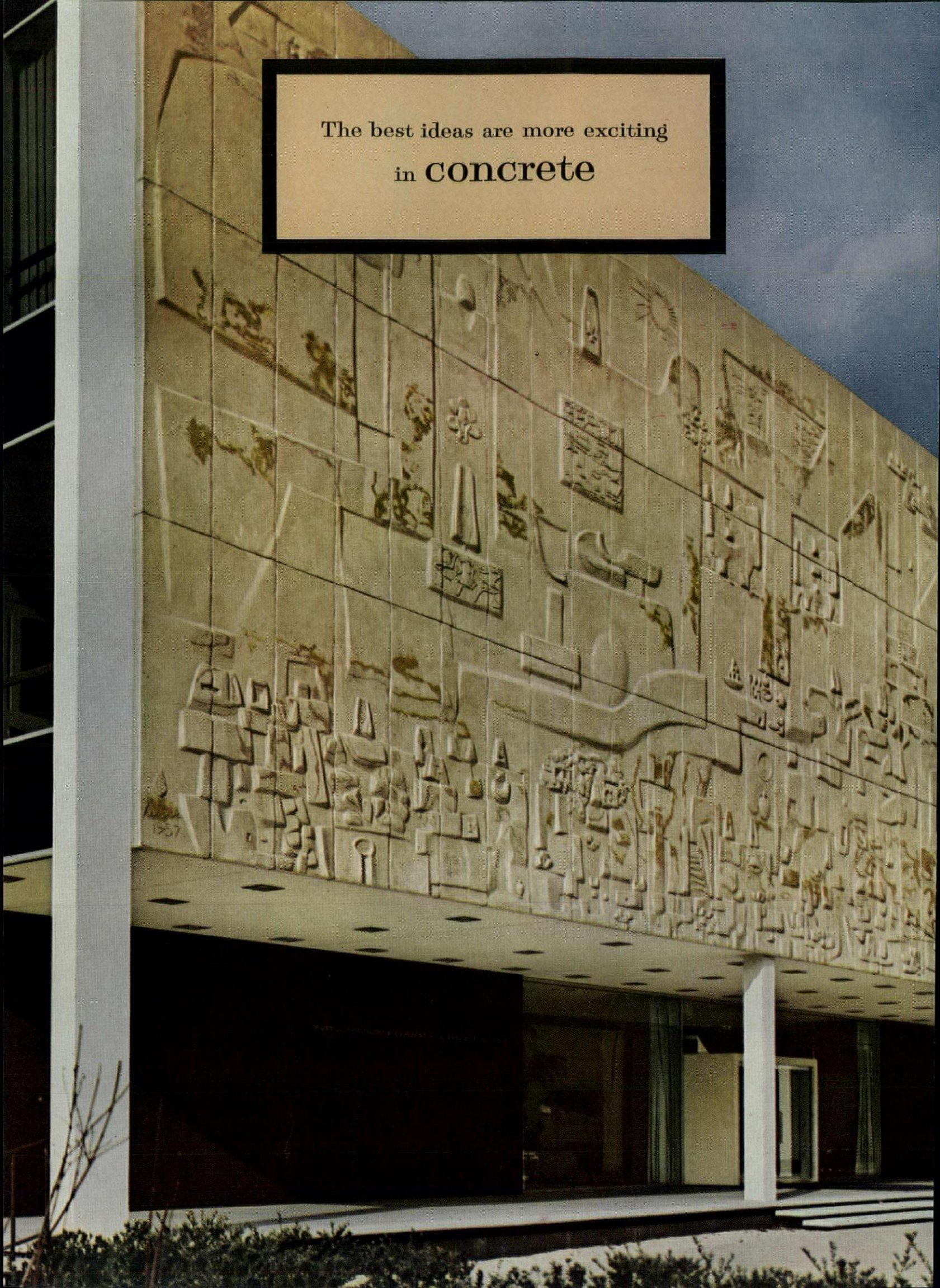

Precast concrete and sand molds make "sculptured walls" come easy!

To achieve the design effect sought for the new Hartford, Connecticut, headquarters of Mutual Insurance Company of Hartford, the architects chose precast concrete. With it they turned the fronting wall into an heroic bas-relief of striking beauty.

Famed sculptor Costantino Nivola "carved" the designs in damp sand. Cast directly from these sand molds in 132 panels, the concrete captured all the detail and rich texture of the original sculpture. Color variations on buff-toned background increase the feeling of depth.

This is just one example of how today's architects are using concrete to create outstanding decorative effects. In buildings of every size and type, concrete fits both free-ranging imagination and functional requirements.

PORTLAND CEMENT ASSOCIATION

A national organization to improve and extend the uses of concrete



Spectacular clubhouse created for the Elks at Duncan, Oklahoma, was made possible by an inches-thin shell roof of modern concrete.



Unique house of worship, Zion Church, Milwaukee, Wis., gets strength and character from walls of concrete hyperbolic paraboloids.

Mutual Insurance Company of Hartford. Architects: Sherwood, Mills & Smith, Stamford, Conn. Structural Engineers: Werner-Jensen & Korst, Stamford, Conn. Elks Clubhouse. Architects: Cottingham and Cook, Lawton, Okla. Structural Engineers: Wilson & Associates, Oklahoma City, Okla. Zion Evangelical and Reformed Church, Architect-Engineer: W. P. Wenzler, Milwaukee, Wis.

INTRODUCING

signature

MOVABLE WALLS
BY HAUSERMAN

New slim appearance,
New functional design,
New approach to sound control
... ideal for commercial
and industrial buildings



*If it's new...
you'll find it first
in Hauserman*



MOVABLE

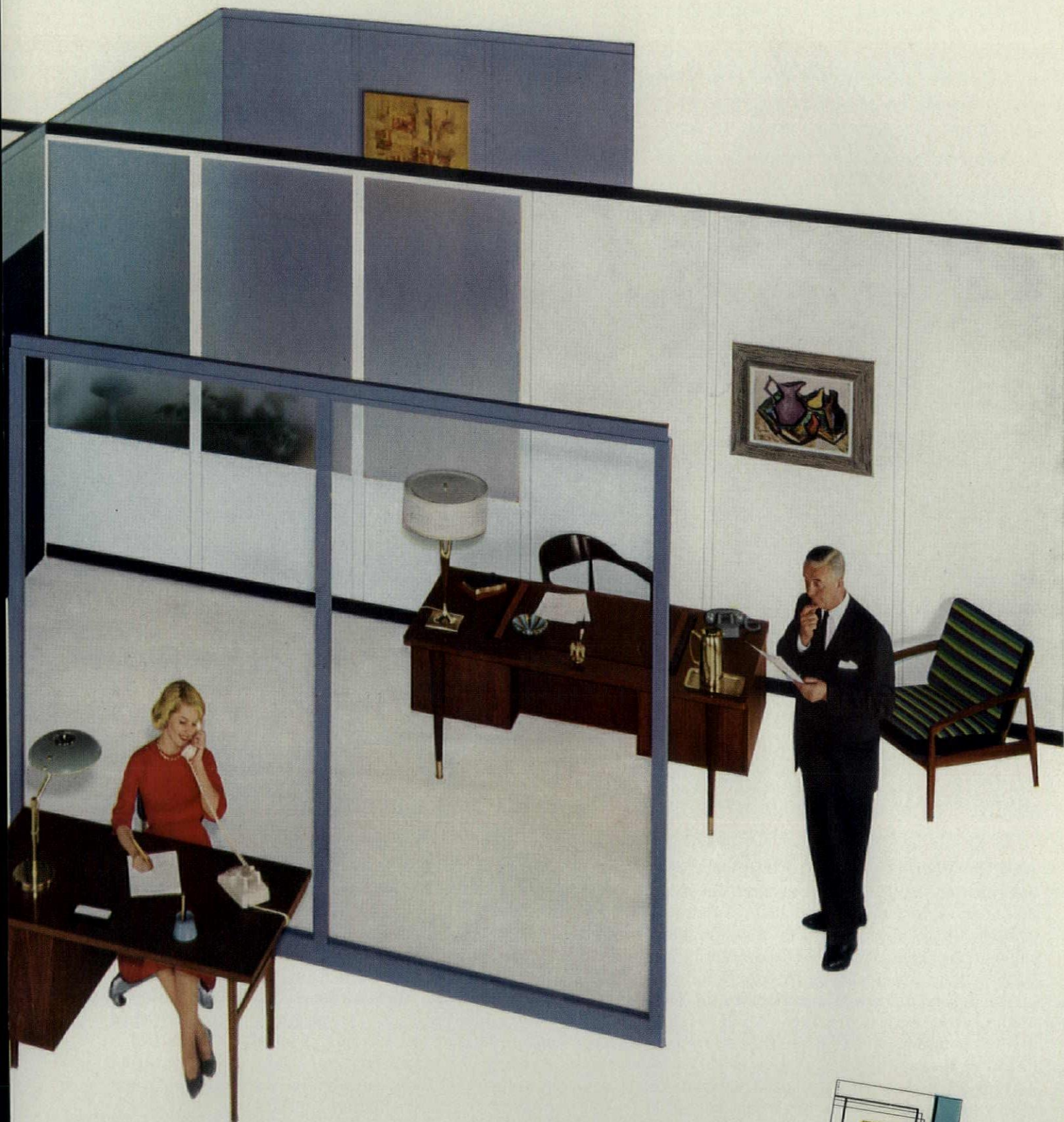

All-new Signature combines the slimness of contemporary design with all the functional benefits a movable wall system should have... **NEW SLIM APPEARANCE**—Panels only 2¼" thick provide strength without bulk. Trim 2¼" square posts join the completely flush panels, creating a clean, two-line joint... particularly effective with glazed units. Compact, simply-defined, new door unit design eliminates vertical strike. Choice of recessed or overlapping base and ceiling trim... **NEW FUNCTIONAL DESIGN**—Signature's 2¼" square universal post permits intersecting the modular panels in any or all of four directions... Wall units are completely movable, easy to relocate. Electrical switches and outlets install quickly with ready access to wiring in posts, base and ceiling trim. **NEW SOUND CONTROL**—All Signature components—base, ceiling trim, post caps, etc... join mechanically with a continuous, zipper-like grip. Entire perimeter is sealed against sound leaks by a flexible gasket. Result: quietest rooms possible with either fixed or movable walls. For the full story, call your Hauserman representative. He's listed in the Yellow Pages under "Partitions."

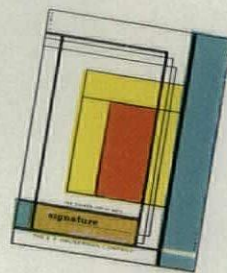

See Sweet's Architectural File No. 22a or write:
The E. F. Hauserman Company
 7154 Grant Ave., Cleveland, Ohio
 for free Signature brochure.

HAUSERMAN INTERIOR WALLS

* Patents pending on distinctive features of Signature design.

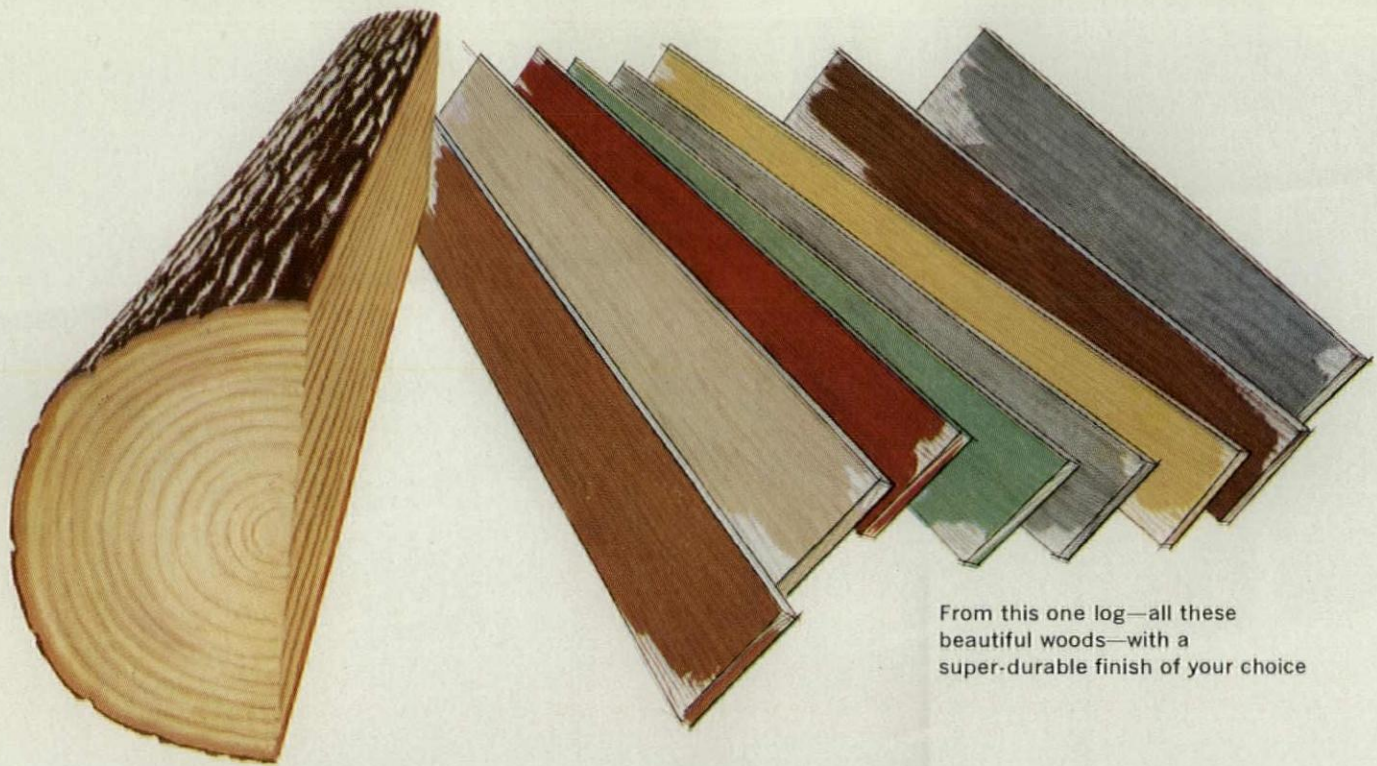

From this one log—all these beautiful woods—with a super-durable finish of your choice

AMERICAN-MARIETTA'S WOOD FINISHING SYSTEM WORKS WONDERS WITH WOOD

...using versatile **INTEX** and **LIQUID GRANITE FINISHES**

American-Marietta's Wood-Finishing System has been hailed as the simplest and most effective system ever developed for securing an almost limitless selection of colors, surface tones and wood-grain effects—for beautifying and protecting exterior surfaces, and for glorifying interior woodwork. The products used are few—and they are the finest that modern research can produce. Application is easy, involving fewest steps. With this system of wood finishing, inexpensive woods glow with the richness and luxury associated with costly cabinet woods.

If your special need is for a custom finish, A-M can provide it. Wood-finishing experts at American-

Marietta, utilizing some of the world's most modern research laboratories, invite you to bring them your toughest problems. This staff will work with you every step of the way—even demonstrating any desired special finish on the wood of your choice. Here, literally thousands of wood-finishing formulas are at your disposal—for purposes ranging from the mirror-like finish of a grand piano to the enriched natural color of exterior woodwork. Whether a finish is to be brushed, sprayed, rubbed or lithographed, A-M can supply the right products and suggest the most effective application.

May we mail you A-M's colorful new Wood-Finishing Brochure, showing 10 Intex colors on 6 typical woods? Write to:

American-Marietta Company, Chicago 11, Illinois
In Canada, 687 Wellington St., Ottawa 4, Ontario



WOOD FINISHES

A-M Mark of Quality

designed to harmonize with your buildings...

NORTON TRIMLINE SERIES 1500 DOOR CLOSER

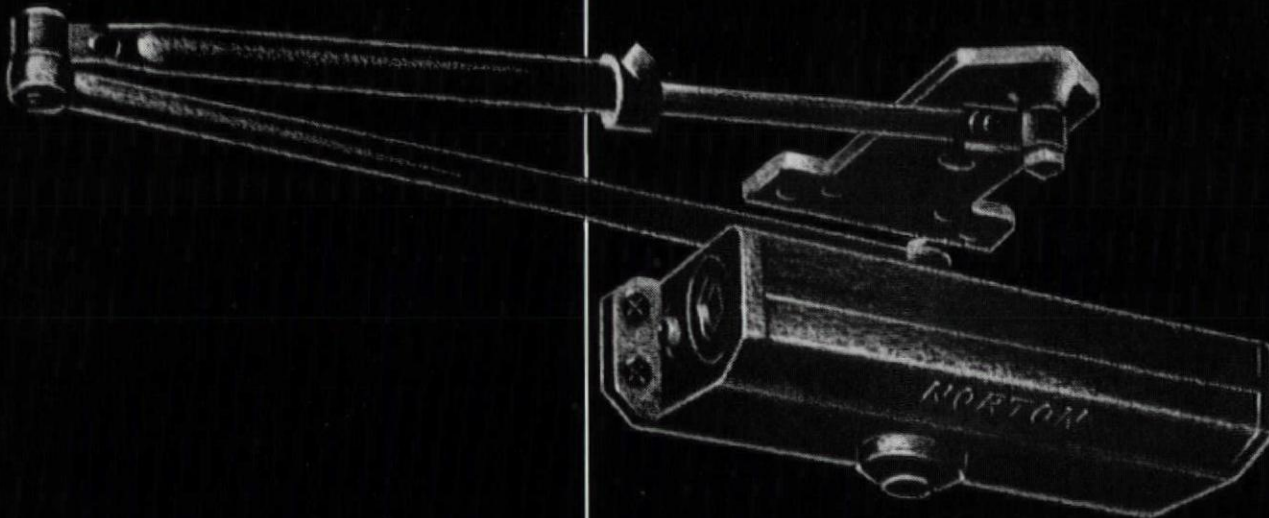

• Norton's new Trimline is specially designed to complement the good taste and artistic expression of your buildings. This rugged door closer combines function, beauty and performance.

The Trimline is non-handed, suitable for either interior or exterior surface mounting. It is a compact rack-and-pinion closer—projecting as little as 3 inches from the door. Write for complete details; ask for Manual T.

1007

NORTON®

DOOR CLOSERS

Dept. AF-40, Berrien Springs, Michigan



Color and form for the Time & Life Building...through



GLASS BY AMERICAN-SAINT GOBAIN

Imaginative uses of ASG products are of course gratifying to us. Especially so, when our glasses contribute to a design as strikingly successful as Rockefeller Center's new Time & Life Building. The debut of ASG's polished, wired glass as a facing material is a landmark in curtain wall technology—as well as an apt solution to the specific problems which confronted the architects. Harrison & Abramovitz & Harris further demonstrate the freshness of their approach by their specification of a noted ASG spandrel glass for a dramatic interior application. American-Saint Gobain Corporation.

BLUE RIDGE HUETEX®—tempered glass facing—adds luxury and drama to the Time & Life Building's spacious lobby. These textured glass ceiling panels, with a layer of deep red ceramic enamel fused to the back, shimmer richly in reflected light from the down-spots which pierce them at intervals.

Architects: Harrison & Abramovitz & Harris
Glazing Contractor: David Shuldiner, Inc.
General Contractor: George A. Fuller Co. & John Lowry, Inc., A Joint Venture

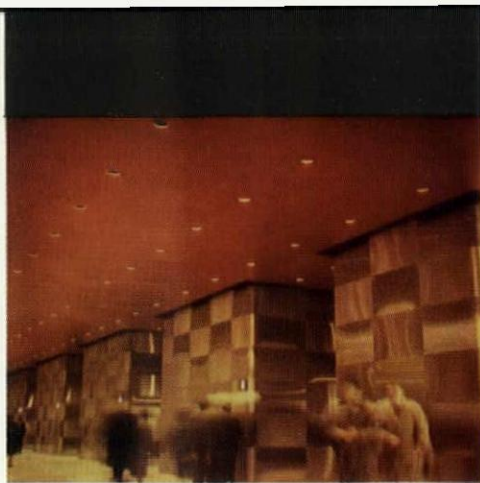

BLUE RIDGE HUEWHITE® is used extensively for partitions in the new Corning Glass Building, 717 Fifth Avenue, New York City. This elegant, translucent white glass reduces glare and insures privacy. It transmits softly diffused light and true color. The finely engraved, non-directional pattern makes a rich, distinctive surface, yet is easy to clean.

Architects: Harrison & Abramovitz & Abbe
Interior Designers: Designs for Business, Inc.

Harrison & Abramovitz and associates
produce striking innovations
with these versatile ASG glasses

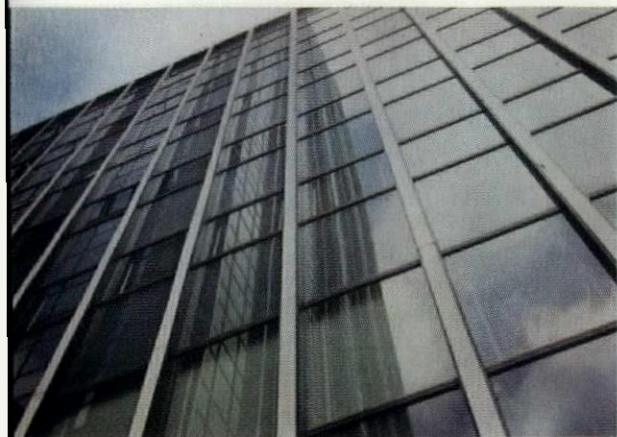

POLISHED, WIRED GLASS—200,000 square feet of it—gains new importance as a curtain wall material. Applied as a facing, but separated from the masonry spandrel (which is covered with aluminum mesh) by an air space, the wire pattern produces a subtle textured effect. Maintenance, of course, is minimal.

The installations and samples pictured here suggest the variety of ways in which American-Saint Gobain glasses can contribute to your plans. Every important type of flat glass—in the widest range of characteristics, sizes and designs—is available to you from this one source.

For detailed information, see the following Sweet's files: *Architectural*: 7a/Am . . . 16d/Am . . . 3e/Am. *Industrial Construction*: 6a/Am . . . 3b/Am. *Light Construction*: 2e/Am. *Plant Engineering*: 5b/Am.

For other information, call the American-Saint Gobain district office nearest you . . . or write:

AMERICAN-SAINT GOBAIN CORPORATION
Dept. AF-10, 625 Madison Ave., N. Y. 22

AMERICAN-SAINT GOBAIN CORPORATION



LUSTRAGRAY®
gray tinted window glass
Reduces glare approximately 50% without sacrificing vision. Exterior opacity contributes to privacy. Neutral shade does not restrict decor. Thicknesses: 3/16" . . . 7/32" . . . 1/4".



RANDEX
decorative patterned glass
Newly styled for striking visual effects. Random, parallel striations in relief on one surface . . . matte texture on the other. Available with Satinol® finish for increased obscurity. 7/32" thick.



AKLO®
heat absorbing glass
Dissipates most solar heat. Maximum light transmission in portion of the spectrum most restful to the eyes. Resists thermal shock. Many combinations of patterns, finishes, thicknesses.



DESIGNED SATINOL®
patterned and textured glass
One of six patterned glasses further enhanced through additional surface treatment by the exclusive Satinol process. Eight motifs currently available. Thickness: 7/32".



Flush block ceiling blends well with other masonry. Long unbroken spans.

SAFE, ECONOMICAL FLOOR AND ROOF SYSTEMS

from the wonderful new world of **BLOCK**

FIRE safe floor and roof systems of concrete block deliver safety first where safety counts—in homes, schools, hospitals and industrial buildings. Combines beauty and practicality. Construction is faster. Provides natural insulation against changing weather conditions. Assures better acoustics. Can be painted or left exposed. Your local NCMA member can give you complete information on the types of systems available.

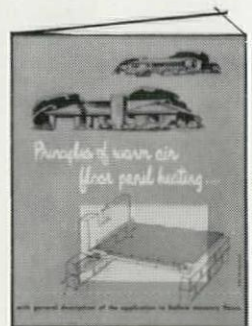

The booklet "Principles of Warm Air Floor Panel Heating" describes how heating systems are particularly adaptable to concrete block floor and roof systems. For your copy, write us direct, enclosing 20c to cover postage and handling.

NATIONAL CONCRETE MASONRY ASSOCIATION • 1015 WISCONSIN AVE., N.W., WASHINGTON 7, D.C.

Speedy erection immediately forms a dry working area for other trades, cuts building costs.

Recessed block ceiling delivers a handsome exposed beam and acoustical block pattern.

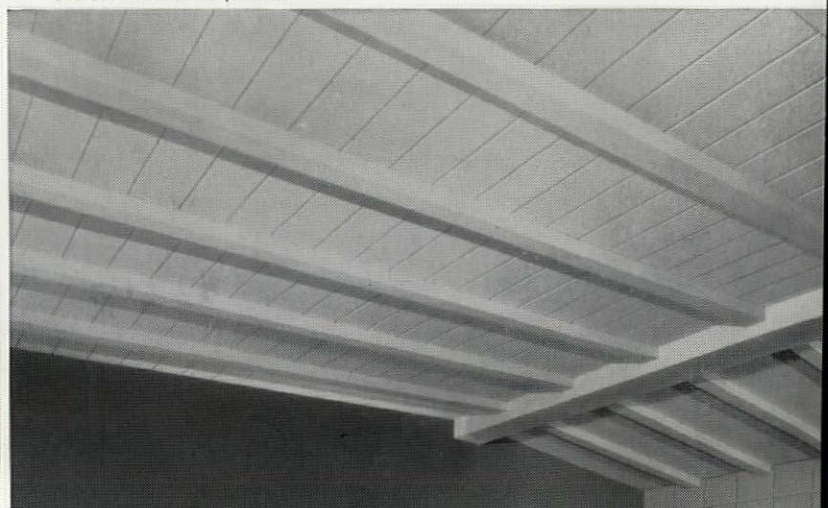



Executive Office, Connecticut General Life Insurance Co., Hartford

Interiors designed by the Knoll Planning Unit

An imaginative treatment of interior space by
the Knoll Planning Unit. May we send further in-
formation to you on Knoll Furniture and Fabrics?



KNOLL ASSOCIATES, INC., AND KNOLL INTERNATIONAL, LTD., 575 MADISON AVE., NEW YORK 22

Boston, Chicago, Dallas, Detroit, Miami, New York, Philadelphia, St. Louis, San Francisco, Washington.

Skidmore, Owings and Merrill, architects Idaka, photograph

WALLS

New Approaches to Old Problems with Modern Products by Johns-Manville

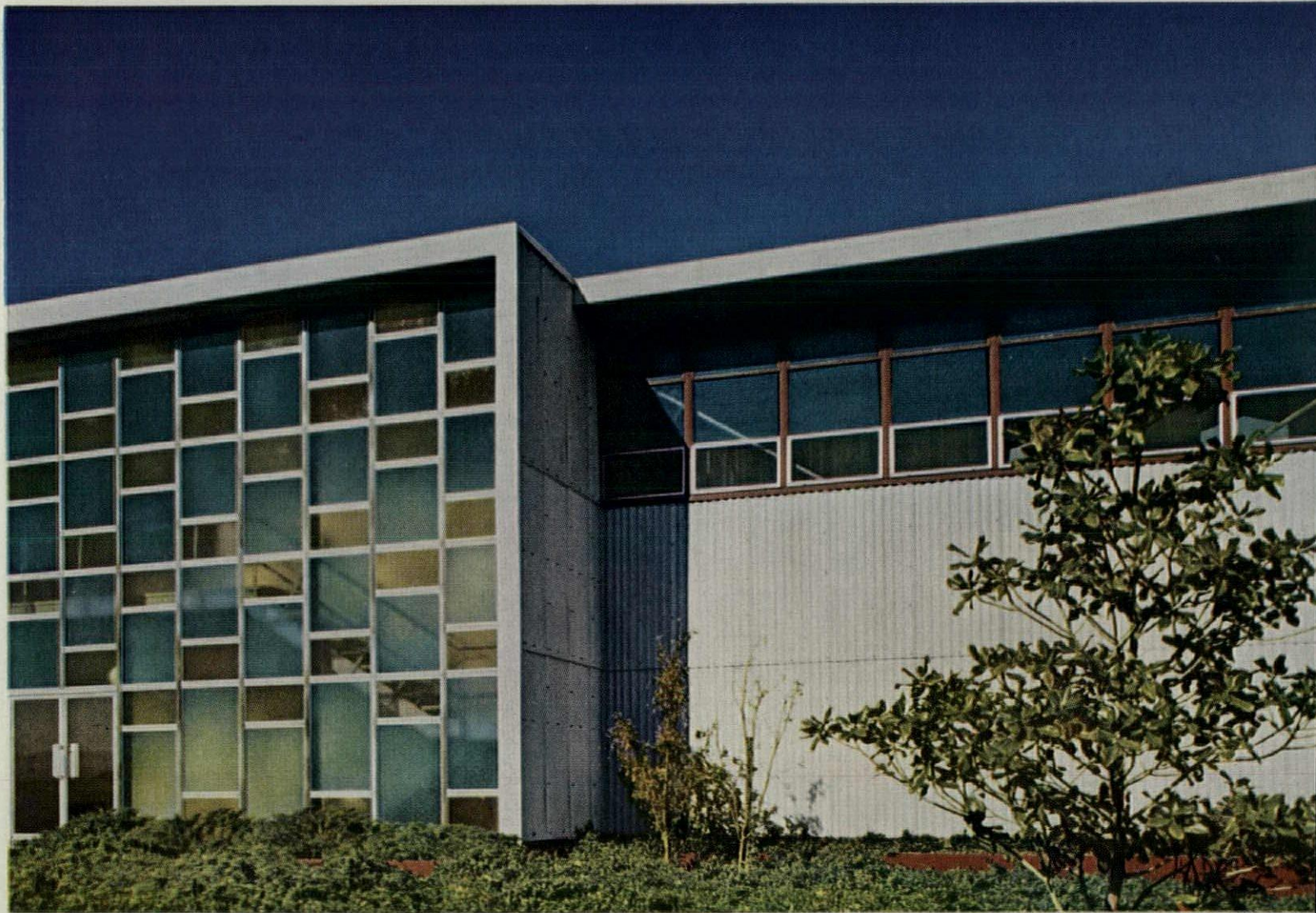

ASBESTOS WALLS . . . Soffits of the overhanging roof, window spandrels and returns at the entrance of this plant are Flat Transite. Large panels of fire-safe economical Corrugated Transite are used for the main wall areas. These structurally strong asbestos-cement sheets can be used equally well with steel frame construction or with wood framing.





DIRECTIONAL WALLS . . . Sheets of J-M Corrugated Transite erected horizontally provide a strong directional accent at the entrance of this building. These asbestos-cement panels can be used painted or in natural stone-like gray.



MASSIVE WALLS . . . The massive main element of this power plant is faced with Corrugated Transite . . . structural panels that combine fine appearance and permanence.

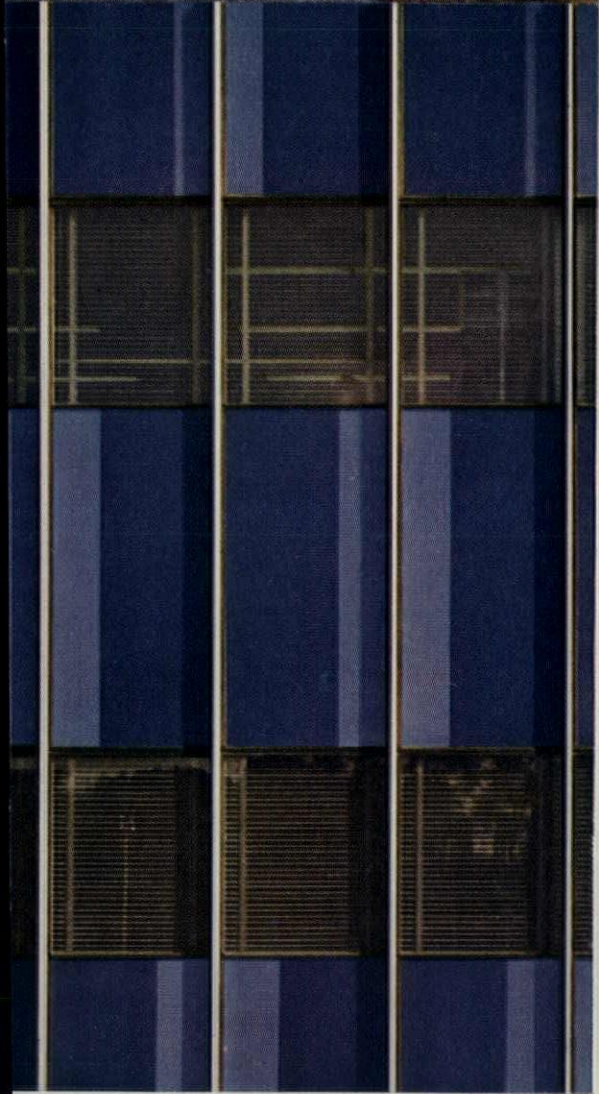

Interesting and functional approaches to the handling of exterior walls—and exciting design potentials adaptable to a wide range of building types—become available with the use of Johns-Manville building products. Shown here are recent applications on buildings in different sections of the United States.

For more than a century, Johns-Manville has been famous for its leadership in research and in the development of quality building products. This knowledge and experience is available through Johns-Manville building specialists who can be reached by contacting Johns-Manville, Dept. AF-4, Box 158, 22 E. 40th St., New York 16, N. Y. In Canada, address Port Credit, Ontario.

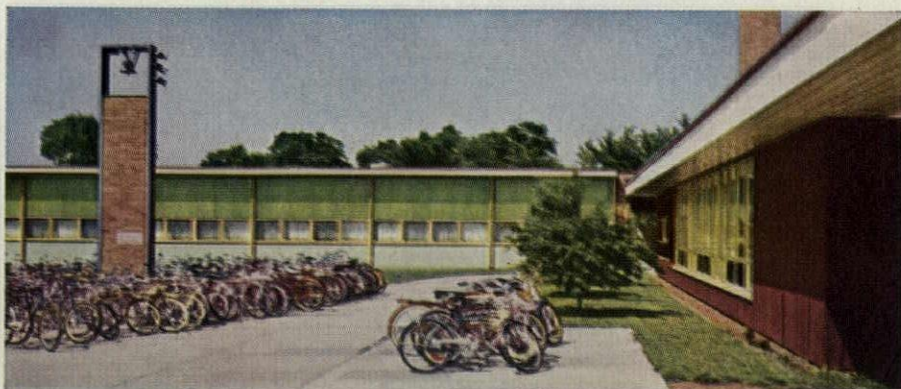

TRANSLUCENT WALLS . . . Johns-Manville Corrugulux reinforced fiber glass panels combine design with function . . . to provide soft, natural interior lighting. Use these shatterproof translucent panels anywhere, corrugated or flat. Available in a wide range of colors.

THIN WALLS . . . Here, porcelain on metal skin was laminated to both sides of Johns-Manville Micro-Flexboard for a total thickness of only 5/16". These curtain walls have no waviness; stay uniformly flat. Virtually any finish can be laminated or applied.

TWIN-PURPOSE WALLS . . . By using J-M Transi-top for the walls of this laboratory, both interior and exterior finish are provided by one material. The large, quickly installed panels consist of an insulating core faced on both sides with strong, tough asbestos-cement sheets.

JOHNS-MANVILLE



TRANSITE, MICRO-FLEXBOARD, TRANSITOP, CORRULUX are registered trademarks of the Johns-Manville Corporation.



ARCHITECT SPECIFIED for better home design

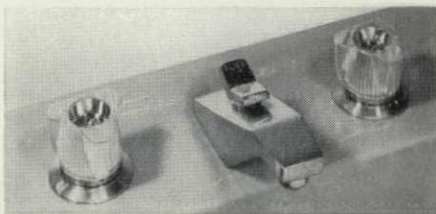

NEW LUXURY BRASS FITTINGS

Sparkling new brushed chrome fittings with plastic prism handles add beauty to any installation . . . another popular new element in design from Eljer.

"Attractive, functional styling . . . modern, clean-line design . . . choice of colors and models . . . fine, hand-rubbed wood cabinets . . ." These were some of the features specified by architects when we asked them what they wanted in a completely new, first-quality lavatory.

You will find all these features (and many more) in this beautiful new *Brent* lavatory-cabinet combination. That's why we call it *architect specified* . . . it was designed for *you* in planning today's modern, attractive homes. Send today for complete specifications.



1,850,000 CONSUMERS WILL SEE THIS AD!
More than 1,850,000 prospective homeowners will be presold on the new *Brent* lavatory and *Luxury Brass* fittings when they see this full-page, four-color ad appearing in current issues of leading consumer magazines.

ELJER

Division of The Murray Corporation of America

Three Gateway Center, Pittsburgh 22, Pa.

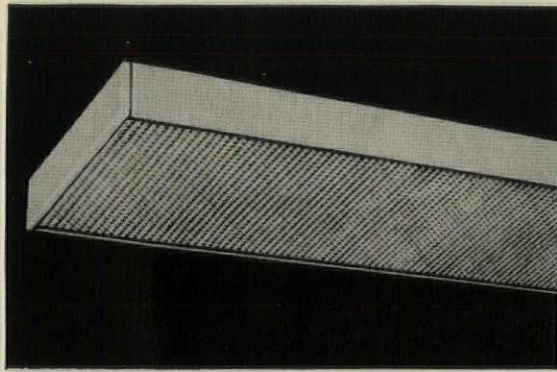

IT LOOKS RIGHT

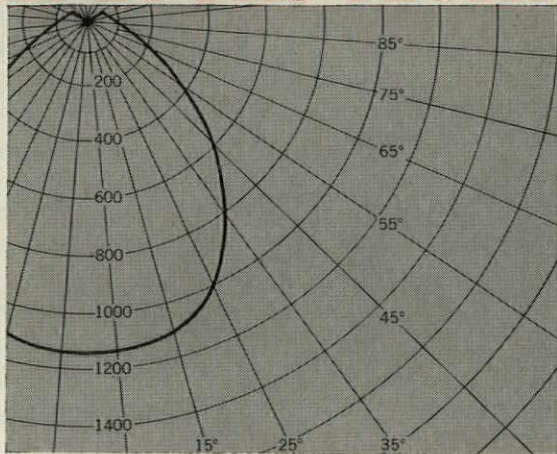

IT LIGHTS RIGHT

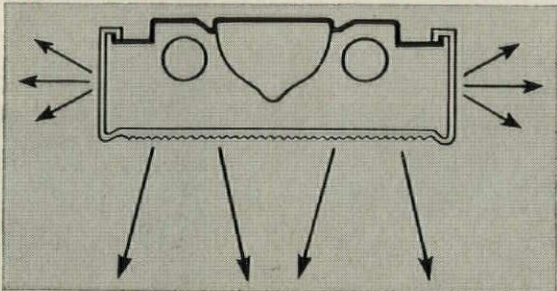

IT'S MADE RIGHT
WITH EVENGLO®

Lightolier's new Primalux fixture is only $3\frac{7}{8}$ " deep, so it hugs the ceiling with a built-in look. **It Looks Right.** It spreads the light evenly in the 0° - 45° zone and also reduces brightness in the direct glare 45° - 90° zone. **It Lights Right.** The diffuser is made from Koppers light-stabilized EVENGLO® polystyrene, a plastic that comes in a wide range of colors, can be extruded into a variety of shapes, and is tough enough to cope with a heavy-handed maintenance man. **It's Made Right.** For more information on EVENGLO polystyrene, or for a list of manufacturers using EVENGLO in fluorescent fixtures, write to Koppers Company, Inc., Plastics Division, Dept. AF-40, Pittsburgh 19, Pennsylvania. Offices in Principal Cities • In Canada: Dominion Anilines and Chemicals Ltd., Toronto, Ontario

KOPPERS PLASTICS





A New Dimension in Sign Advertising!

AMPLEX 3-D PLEXIGLAS* LETTERS

Attention-Commanding! Precision formed from heavy gauge—(yet light in weight)—Plexiglas, ultra-modern Amplex letters add a distinctive touch which will make a store or place of business stand out and attract attention. Their permanent rich lustre and unusual 3-dimensional effect beautifies and adds prestige wherever they're used . . . outdoors or indoors.

Versatile! Durable, color-fast, weather resistant, Amplex letters are available in 14 different colors—6 styles—in sizes from 2" to 72"—with depths from 1" to 6".

Economical! Easy to install, they can be mounted on any type of background material—wood, brick, glass, marble, stainless steel, porcelain enamel, etc. Amplex letters never need painting or any other maintenance except for an occasional cleaning with soap and water.

• Even with all these high quality features, Amplex letters are comparatively inexpensive. Truly, they're your best value for your sign advertising dollars.

• Sold and installed exclusively by local sign companies throughout the United States and Canada.

• Upon request, we'll send you a colorful brochure along with name of sign company near you handling these letters.



Dep't A
2325-31 FAIRMOUNT AVE.

Philadelphia 30, Penna.

*Reg. T.M. Rohm and Haas Co.

© 1960 Amplex Manufacturing Co.

WORLD'S LARGEST MANUFACTURER OF PLEXIGLAS LETTERS FOR SIGNS!

Air-Skreen sparks new ideas in SUPERMARKET PLANNING

Air-Skreen is an all-new integrated display and storage merchandiser which saves steps, reduces product handling, cuts labor costs; by providing fast, easy rear-loading of display from within storage cooler itself. It can be used in separate, single units—or in multiple, continuous display. For details consult Tyler Distributor listed in Yellow Pages, or send coupon.



TYLER

PIONEER of important improvements

TYLER REFRIGERATION CORPORATION, Niles, Michigan

See our catalog in Sweet's Architectural File—26a/Ty

Tyler Refrigeration Corporation, Dept. AF-4, Niles, Mich.
Send data on new Tyler Air-Skreen Sales & Storage Cooler free Store Planning Assistance available to architects.

NAME _____

ADDRESS _____

Canada: Tyler Refrigerators, 732 Spadina Ave., Toronto. Export: Tyler Refrigeration Int'l., C.A., Apartado Postal 9262, Caracas, Venezuela, S.A.

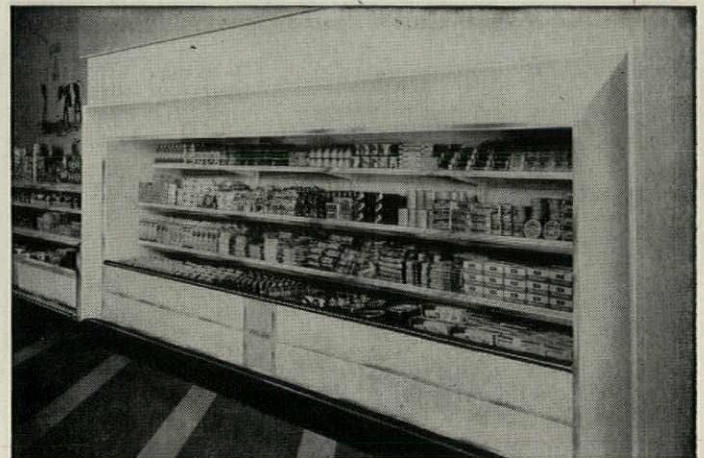

Every store has its own requirements, but Air-Skreen opens new solutions, new arrangements, new shortcuts to better store layout, more efficient operation.

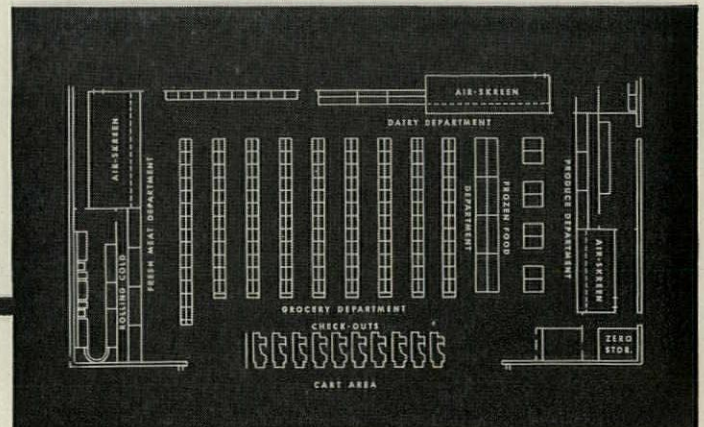

Air-Skreen makes possible various perimeter arrangements which provide short, direct flow of merchandise from receiving to combination sales and storage cooler.

here's
STRENGTH
 where it counts...
 in the
HARDWARE

Get away from coatings and plating, and you have the solid-metal strength and durability that's needed in toilet compartment hardware.

That's why Fiat *LIFE-LINE Harmonized Hardware* is solid-to-the-surface selected alloy... aluminum above the floor, stainless steel for floor shoes... all in a harmonizing satin finish that blends with any decor.

It's top quality, furnished without exception for every Fiat Enclosure installation because it's been tested and proved best for the purpose.



S-2 Alloy Wall Stirrups



S-2 Alloy Top Hinge Bracket

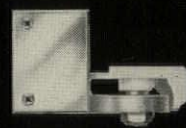

S-2 Alloy Bottom Hinge Bracket

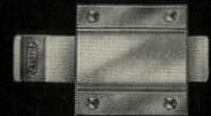

S-2 Alloy Slide Bolt



Stainless Steel Plinth

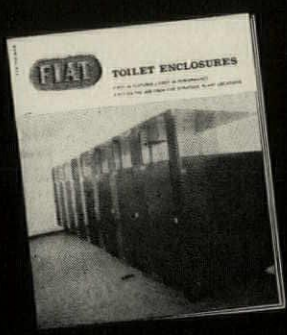

Send for new Brochure: "Fiat Toilet Enclosures" to get the facts about the FIAT line, as well as architectural details and specifications.

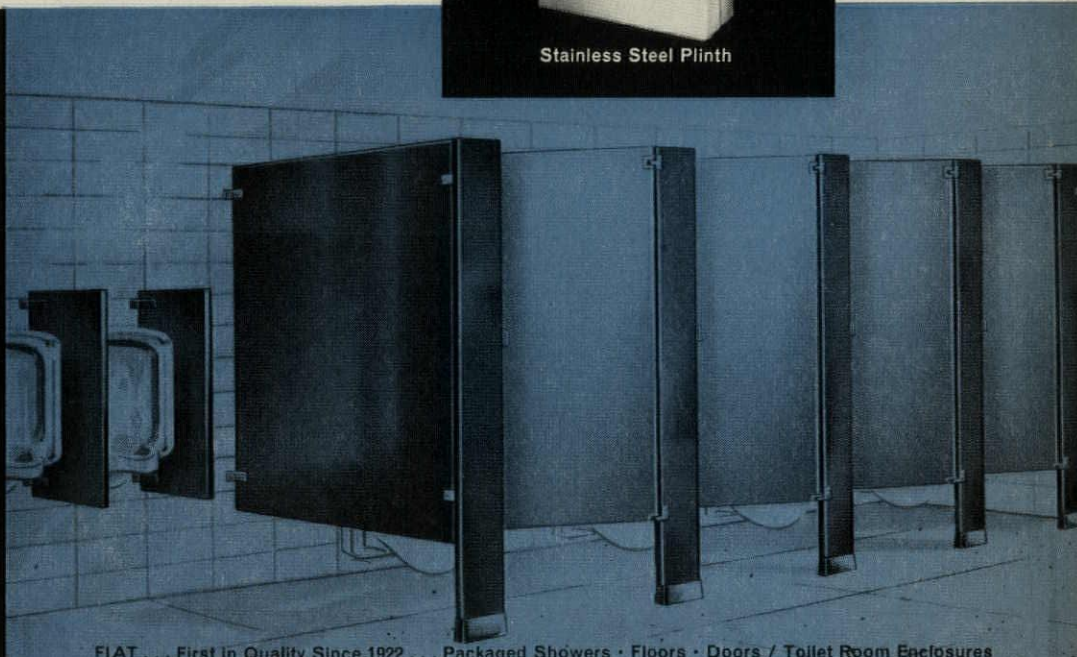

FIAT... First in Quality Since 1922... Packaged Showers • Floors • Doors / Toilet Room Enclosures

5

STRATEGICALLY LOCATED PLANTS FOR FAST DELIVERY AT LOWER COST!

FIAT
METAL MANUFACTURING CO.
 9301 Belmont Avenue,
 Franklin Park, Illinois



In each of These Modern Buildings...

Maintenance Savings were DESIGNED IN

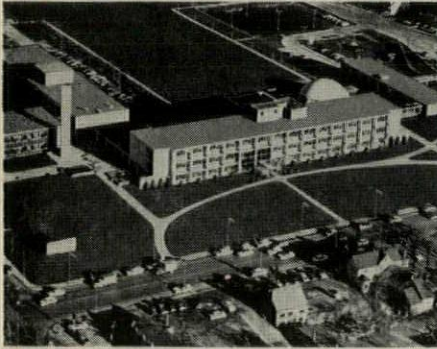

Municipal Center, Flint, Michigan
Architects and Engineers:
H. E. Beyster & Associates, Inc., Detroit

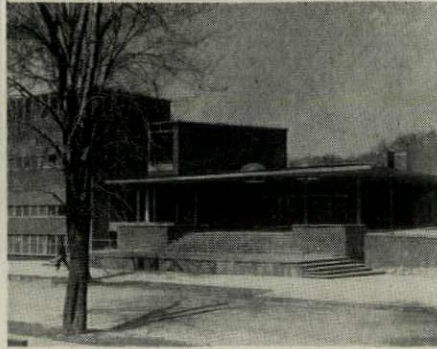

Community Arts Center,
Wayne State University, Detroit
Architect: Suren Pilafian



St. Joseph Hospital, Burbank, California
Administrator:
Sister Agnes of the Sacred Heart

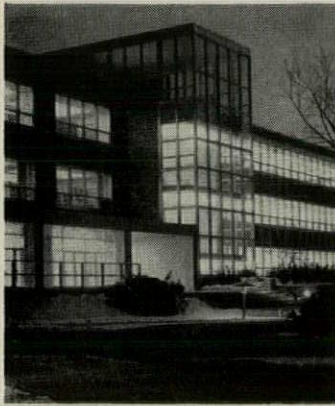

New Library,
Michigan State University
Architect: Ralph R. Calder

with **SPENCER VACUSLOT**®

... the modern, built-in maintenance system that handles ALL these cleaning tasks:

- Dry Mop Cleaning
- Water Pick-up
- Cleaning Walls and Overheads
- Vacuum Cleaning
- Boiler Tube Cleaning
- Venetian Blind Cleaning

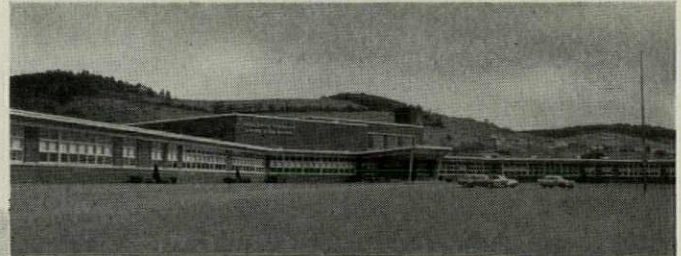

Junior High School,
Loyalsock Township,
Williamsport, Penna.
Architect: John E. Boodon,
Montoursville, Penna.



West Ridge School, Greece, N.Y.
Architect: Benedict Ade—Rochester
Consulting Engineer:
Robson & Woese, Inc.—Rochester

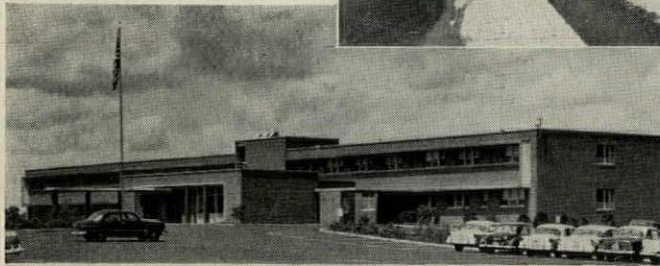

McPherson Community Health Center, Howell, Michigan
Architect: Clark R. Ackley

ALSO MANUFACTURERS OF

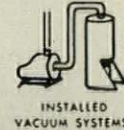
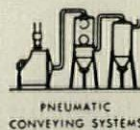

Request
descriptive Bulletins
No. 153D and 157.



The **SPENCER**
TURBINE COMPANY
HARTFORD 6, CONNECTICUT

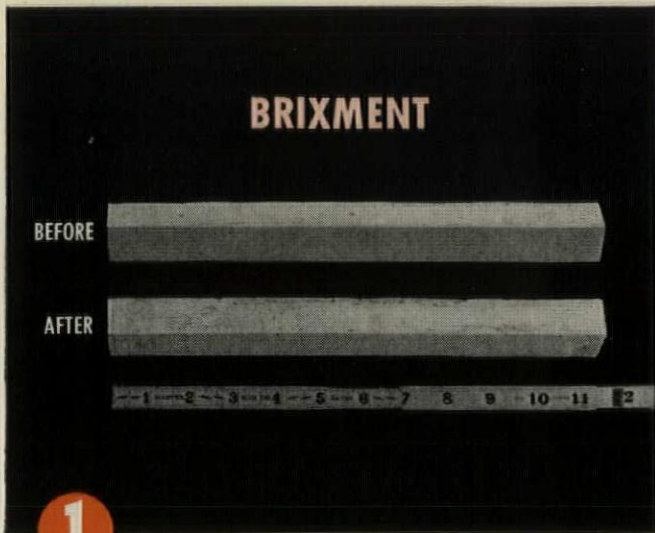

1 In these autoclave tests, the bottom bar in each set of neat cement bars above was exposed to 295 lbs. steam pressure, 420° F., for 3 hours. *Left:* The two bars are both Brixment. Note that it

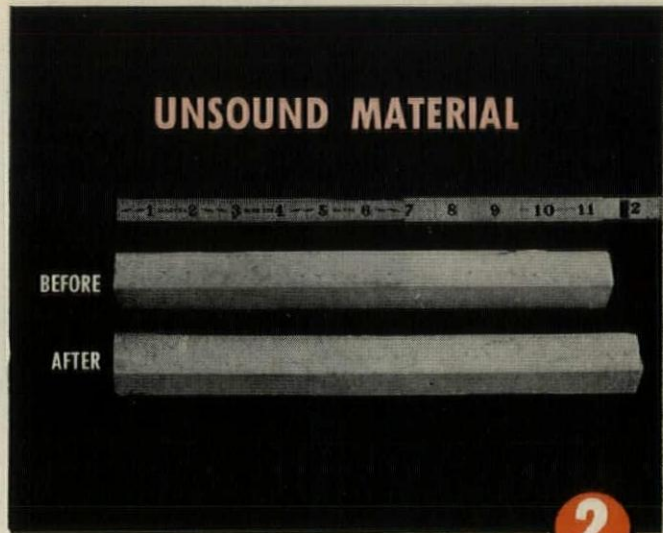

is sound—it has not expanded. *Right:* The two bars were made of one part portland cement and one part of a lime which does not meet autoclave test. Note expansion—proof of unsoundness.

BRIXMENT meets the Autoclave Test for SOUNDNESS!

Sound mortar is essential for strong, durable brickwork. To be sound, mortar must be free of constituents which may cause abnormal expansion after long exposure to weather.

Unsoundness in mortar material is readily detected by the autoclave test. This severe test rapidly accelerates the chemical reaction of mortar materials, and the slightest unsoundness is immediately revealed by excessive expansion.

Brixment easily meets the autoclave test requirements of the Federal and ASTM specifications. It also complies with the strength requirements of both specifications for Type II masonry cement.

Therefore, when Brixment is used, sound, strong, durable mortar is assured.

But soundness is only *one* of the characteristics in mortar necessary to produce top-quality masonry at lowest cost. Several others are listed below—and *no other mortar combines ALL these characteristics to such a high degree as Brixment mortar.* It is this combination of advantages that makes Brixment superior to any mixture of portland cement and lime—and which also accounts for the fact that Brixment has been the leading masonry cement for over 40 years.

Louisville Cement Company, Louisville 2, Ky.

BRIXMENT MORTAR ALSO COMBINES THESE 8 OTHER ESSENTIAL CHARACTERISTICS



PLASTICITY



WATER RETENTION



BOND

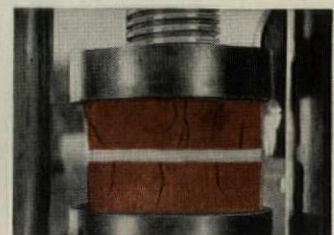

STRENGTH

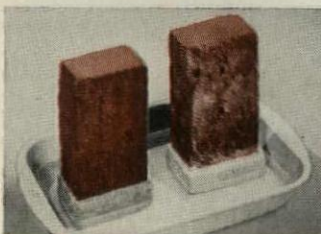

LOW EFFLORESCENCE



IMPERMEABILITY



DURABILITY

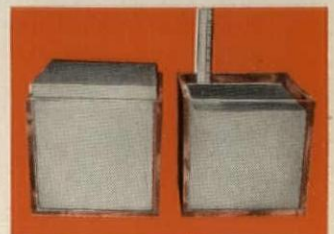

YIELD



36% Commercial Hydrochloric Acid splashed on a LAPIDOLITH treated surface. Note there is no reaction. The concrete surface is unaffected because it has been protected by the chemical hardening action of LAPIDOLITH, PERMITTING ENOUGH TIME TO FLUSH THE ACID AWAY WITH WATER, before the concrete is harmed.

CAN YOUR FLOORS SURVIVE THIS ACID TEST?

LAPIDOLITH protects concrete floors against acid erosion . . . and does it in depth!

Tests conducted by FOSTER D. SNELL, INC., famous independent research organization, show that a concrete floor protected by the chemical hardening action of LAPIDOLITH permits enough time to flush off acids before the concrete is harmed. However, untreated concrete is *instantly* attacked by the acid.

Acid may never be spilled on *your* concrete floors, but they are subject daily to atmospheric acid attack. The American Chemical Society has reported that thousands of tons of corrosive sulphur dioxide are released daily into the atmosphere of the average

industrial city. For example, enough sulphur dioxide is released into the air annually over metropolitan New York area to make approximately 2.2 million tons of sulphuric acid.

Therefore, your concrete floors are constantly exposed to atmospheric acid attack which cannot help but have a disintegrating effect on your concrete floors.

In addition to the protection LAPIDOLITH gives your concrete floors against atmospheric acid attack, here are several more reasons why your concrete floors must be LAPIDOLIZED:—

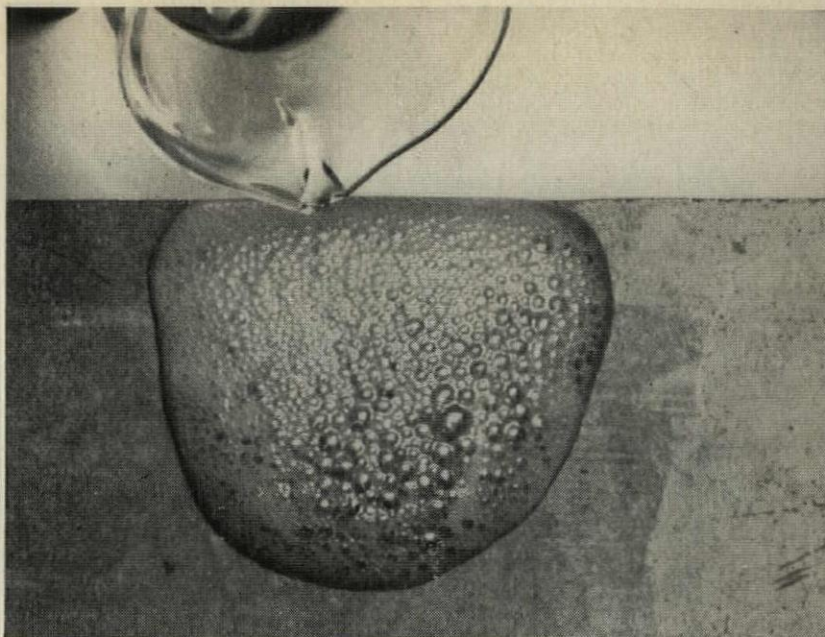
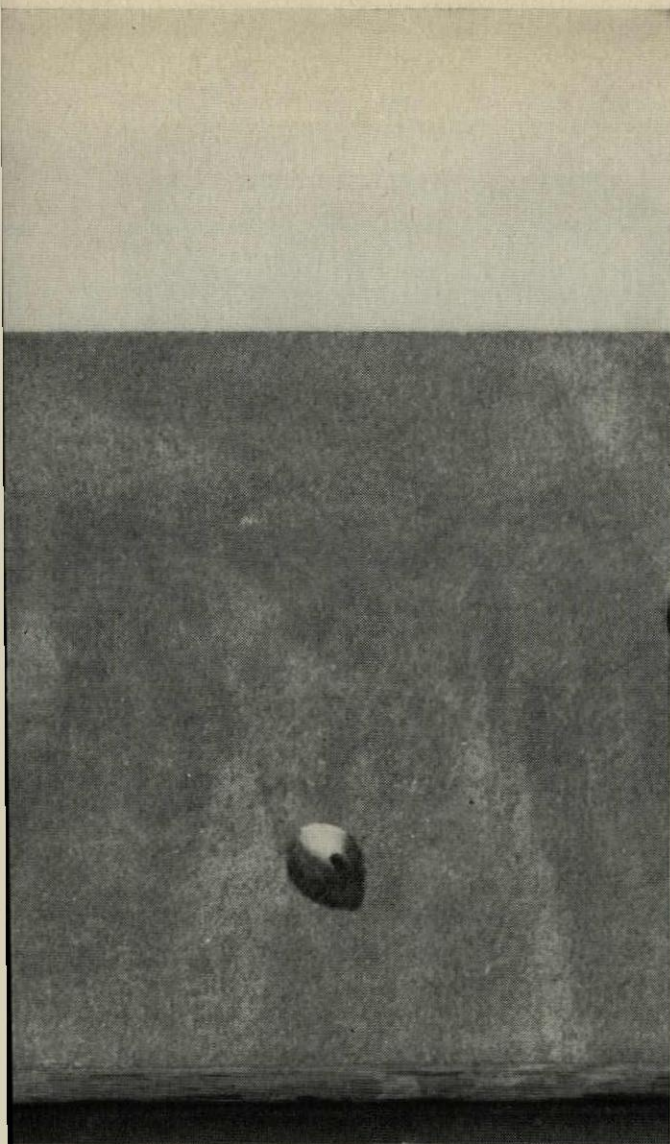

The same concrete was treated with a coat of a typical sealer, which claims sealing, curing and hardening. The sealer was stripped by means of a paint and varnish remover, exposing the bare concrete. The concrete is still instantaneously attacked by acid, proving that the sealer did nothing to change the nature of the concrete, leaving "sealed" concrete which has been scratched or worn, vulnerable to acid erosion.

At no obligation to you, we will have one of our qualified floor specialists make an expert inspection and recommendation to you.

Replacing worn-out concrete floors will cost you many times more than a simple, low cost, application of LAPIDOLITH.

WRITE TODAY FOR FREE INSPECTION

All photos are *actual* and *unretouched* and are of tests made by FOSTER D. SNELL, INC., with their facilities and under their supervision.



**SONNEBORN
CHEMICAL AND REFINING
CORPORATION**

Building Products Division, Dept. AF-40
404 Park Avenue South, New York 16, N. Y.

Always Consult Your Architect or Engineer

ATTACK is violent and instantaneous when 36% commercial Hydrochloric Acid is splashed on untreated high grade concrete.

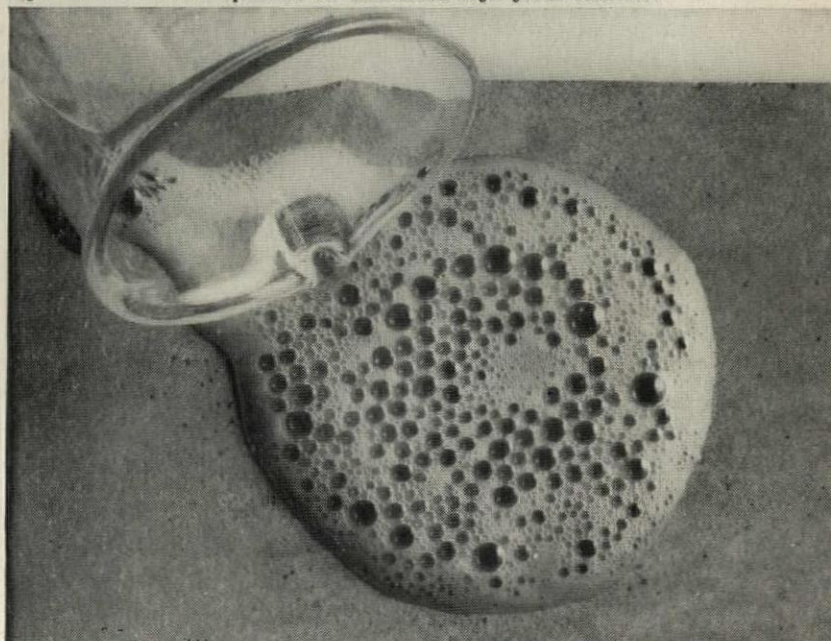

1. ONLY LAPIDOLITH CONTAINS DYNEX®. Because of Dynex, LAPIDOLITH not only chemically hardens the surface, but penetrates deeply into the sub-surface pores and capillaries, giving greater **HARDNESS IN DEPTH.**

2. GUARANTEED—LAPIDOLIZED concrete floors are fully *bonded* and *guaranteed for 5 years* against any dusting as a result of abrasion and wear, when applied under contract by Sonneborn—America's foremost manufacturers of liquid chemical concrete floor hardeners.

3. PROVEN SUCCESS—LAPIDOLITH is the original chemical floor hardener and has been distinguished by having received the famous "Brand-Names-Award." Over half a billion square feet of concrete floors have been successfully LAPIDOLIZED in the past 57 years.

4. EASY TO APPLY—LAPIDOLITH, the original patented chemical floor hardener is a factory prepared, stabilized colorless solution, very simple to apply.

5. "CUSTOM DESIGNED" LAPIDOLITH CONCRETE FLOOR SYSTEM—Only Sonneborn offers you a "custom designed" LAPIDOLITH Concrete Floor System to help *you* with your *specific* floor problem. Sonneborn is the *one* company you can come to with *all* your concrete floor treatment requirements.



WHAT KIND
OF FLOOR
IS RIGHT
FOR
Hawaii

14,450 sq. ft. 33/32" Edge Grain
Ironbound floor in Palama Settlement
Gymnasium, Honolulu,
Hawaii. Arch.: Vladimir Ossipoff,
F.A.I.A., Honolulu. General Contr.:
Harry Kobayashi. Installer: Lewers
& Cooke, Ltd., Honolulu.

Why the architect specified
Ironbound* CONTINUOUS STRIP* HARD MAPLE

One of the outstanding recreational centers in the 50th state is in Honolulu's Palama Settlement. It includes a spacious gymnasium with the finest hardwood floor in the islands — a beautiful Ironbound installation.

This Ironbound floor was chosen for more than its natural beauty and uniform resiliency — it is the *right* floor for Hawaii's climate, too. The hard maple flooring, laid over cork underlayment directly on a concrete slab, is interlocked with sawtooth steel splines for control of normal expansion and contraction. The flooring was also treated with Woodlife preservative to double the normal retention for

positive protection against termites and excessive moisture absorption.

Important, too, was the fact the architect and owners knew Robbins stands behind this floor and sees that it's properly installed.

Indeed, Ironbound was a happy choice for Honolulu, as it has been for thousands of gymnasiums throughout the other 49 states and Canada. For literature and the name of your nearest installer, write Robbins Flooring Co., Reed City, Mich., Attn: Dept. AF-460.

Material for the Palama Settlement Gymnasium was Dri-Vac treated. Specify certified Dri-Vac treatment with Woodlife for wood floors. For unusual conditions, special retentions are available.

*T.M. Reg. U.S. Pat. Off.

ROBBINS
MAKERS OF MODERN MAPLE FLOORS *flooring company*
REED CITY AND ISHPEMING, MICHIGAN.

In-stock
Steel Doors
and
Frames
to architects'
specifications

Aetnapak offers these custom features in steel door & frame packages, in stock for speedy delivery (no custom engineering delay):
Doors constructed of 18-gauge steel, reinforced with continuous, vertical 20-gauge stiffeners spaced 6" on centers. Completely flush design. Uniform clearance. Standard bevelled stiles. Reinforced for closers and other surface hardware. Mortised flush bolts. Order Aetnapak with or without hardware—doors and frames, doors separately, frames separately.
Complete U-L service including "A" labeled Aetnapak Fyr-Chek doors with single-point locks. Smoke screens, borrowed lights and transoms. Send for Aetnapak order-from-stock catalog today.

AETNAPAK®

DISTRIBUTED THROUGHOUT THE UNITED STATES* AND CANADA BY UNITED STATES PLYWOOD CORPORATION.
AETNA STEEL PRODUCTS CORPORATION, 730 FIFTH AVENUE, NEW YORK 19, N. Y.

Other Aetna products: Aetnawall Metal Office Partitioning Systems

*With the exception of the Metropolitan New York area.

AETNA STEEL PRODUCTS CORPORATION
730 Fifth Avenue, New York 19, N. Y.
Please send free catalog of Aetnapak
custom-quality, always-in-stock Steel Doors,
Frames and Hardware.

Name & Title _____

Company Name _____

Address _____

City _____ State _____

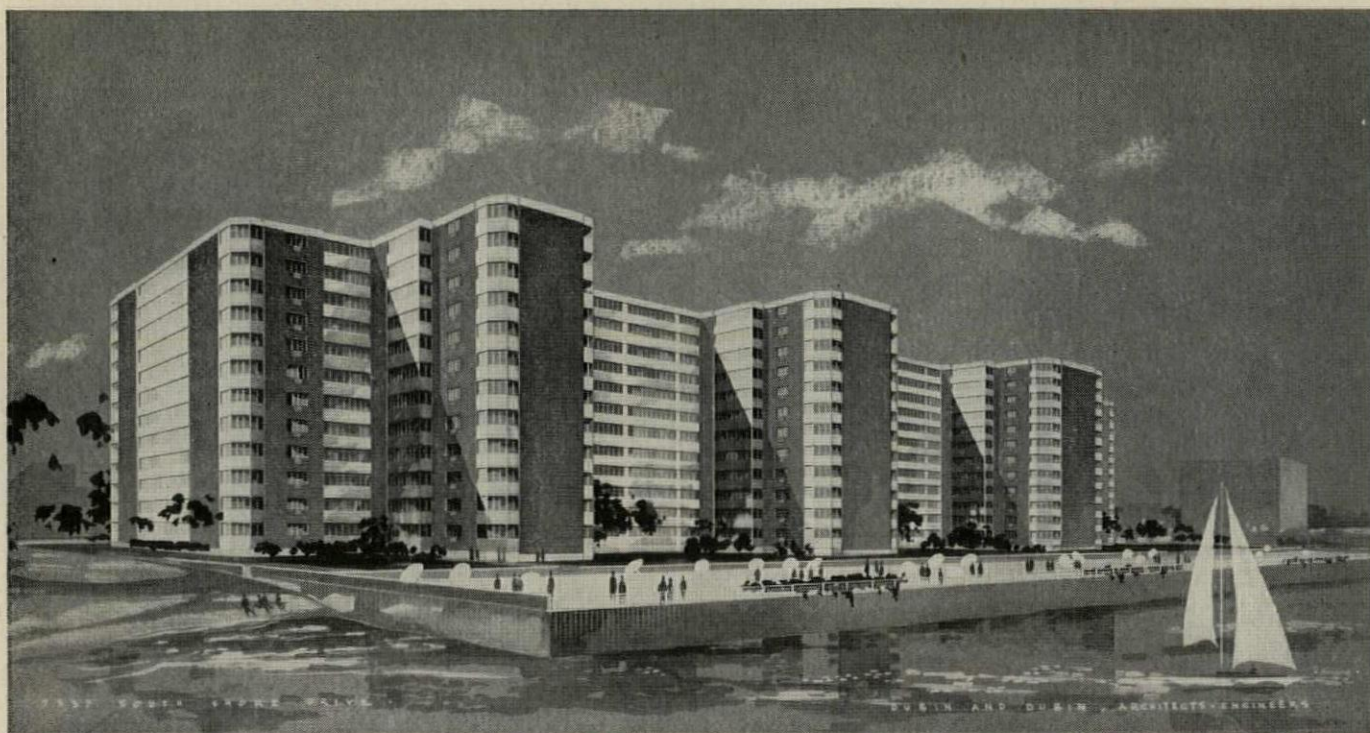

Tenants of this just-completed building don't have to rely on fickle breezes from Lake Michigan. All 364 apartments are air conditioned with General Electric Built-In *Thinlines*.

General Electric Thinlines Air Condition Luxury Apartment on Chicago's Lakefront

778 through-the-wall room units assure comfort throughout building

"Price was only one reason why we chose General Electric *Thinline* Air Conditioners," says Henry Dubin, of Dubin and Dubin, Architects & Engineers. "In product engineering and manufacturing quality, *Thinlines* were the best of all air conditioners we considered.

"And tenants are sure to be pleased with the exclusive decorator-front baffle on all General Electric Built-In *Thinlines*. This baffle conceals the unit and it can be

painted, papered, or paneled to match the walls."

Each living room and bedroom in 7337 South Shore Drive has its own General Electric Built-In *Thinline*. Tenants can control their own comfort; varying the temperature from room to room as they wish.

General Electric *Thinline* air conditioning systems can be tailored to your needs—whatever they may be. *Thinlines* are available in a variety of models, over a wide capacity-range (5,300 to 16,000 B.T.U.'s*).

See your General Electric representative for full details. General Electric Company, Room Air Conditioner Department, Appliance Park, Louisville 1, Ky.

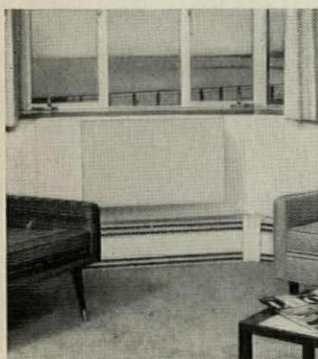

Built-In Thinline Air Conditioners are part of the wall—and they look like it.

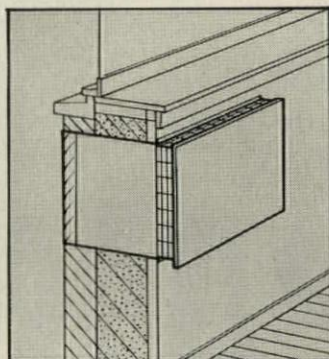

Thinline case is installed during construction. Unit is concealed by decorator baffle.

*Cooling capacities are tested and rated in accordance with NEMA publication No. CN 1-1958.



Progress Is Our Most Important Product

GENERAL  ELECTRIC

this is a fabulous new paint called

metALACE®!

A PRODUCT OF PLEXTONE RESEARCH



It creates a lace-like metallic pattern of silver or gold over a wide variety of glamorous new decorator colors...

an exciting effect previously available only in the most expensive wall papers...now possible with paint at a fraction of the cost!

Your painting contractor applies MetaLace...quickly, easily, inexpensively for long lasting beauty.

Mail coupon for details on this unique new paint product.

PLEXTONE Corporation of America
2126 McCARTER HIGHWAY, NEWARK 4, NEW JERSEY
PACIFIC COAST DIVISION: 10751 VENICE BLVD., LOS ANGELES 34, CALIF.

PLEXTONE Corporation of America
2126 McCarter Highway, Newark 4, N. J.
Please rush color chips & complete data on new METALACE paint.

Name _____
Title (or occupation) _____
Company _____
Street _____
City _____ Zone _____ State _____

"HONEYCOMB"

S

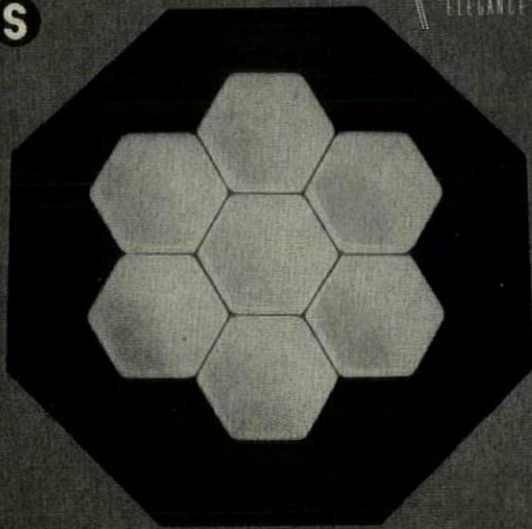

INCANDESCENT SEMI FLUSH
CEILING CLUSTER

7 - 271 dia. 36" 1400 Watts
7 - 287 dia. 42" 2100 Watts

DESIGNED IN EUROPE

write for catalogue

AW PISTOL INC., 8-10 DRAKE AVE. NEW ROCHELLE, NY

**19% MORE STEEL
IN THE MORTAR**

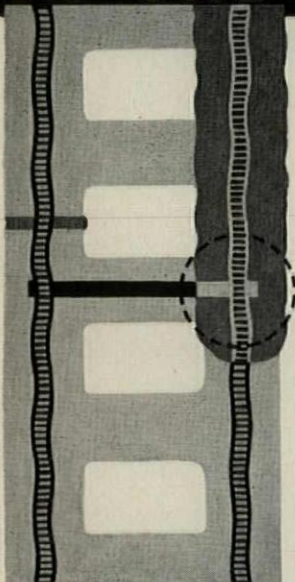

with

WAL-LOK

HORIZONTAL MORTAR
JOINT REINFORCING

Other reinforcing may be heavier but, Grade for Grade and dollar for dollar, WAL-LOK puts more steel in the mortar where it counts - 19.2% more than competitive products. SUPERSTANDARD Grade has 8 ga. Siderods rather than the 9 ga. used by others and it's the Siderods that end up in the mortar. Ladder type construction means no wasted steel to get in the way of insulation, pipe or conduit in the walls • No extra freight on steel that serves no useful purpose. PLUS—many other features at no extra cost.

WRITE FOR NEW DESCRIPTIVE BROCHURE AND NAME OF DISTRIBUTOR NEAREST YOU



WAL-LOK

DIV. of LENAWEE PEERLESS, INC.
1307 E. MICHIGAN • ADRIAN, MICH.

6-IN-ONE

**"BIG SIX"
NEWS FOR
ARCHITECTS**

GENERAL CHEF combines six kitchen-essentials in one compact, efficient unit:

**REFRIGERATOR • OVEN • SINK
STOVE • FREEZER • STORAGE**

Every model available in white or several wood-grain finishes. Entire base unit factory-assembled and shipped in one crate. Available on all units: garbage disposal; one-piece stainless steel tops. And don't forget: GENERAL CHEF is the only Complete Kitchen Unit with factory-owned, nation-wide sales and service.

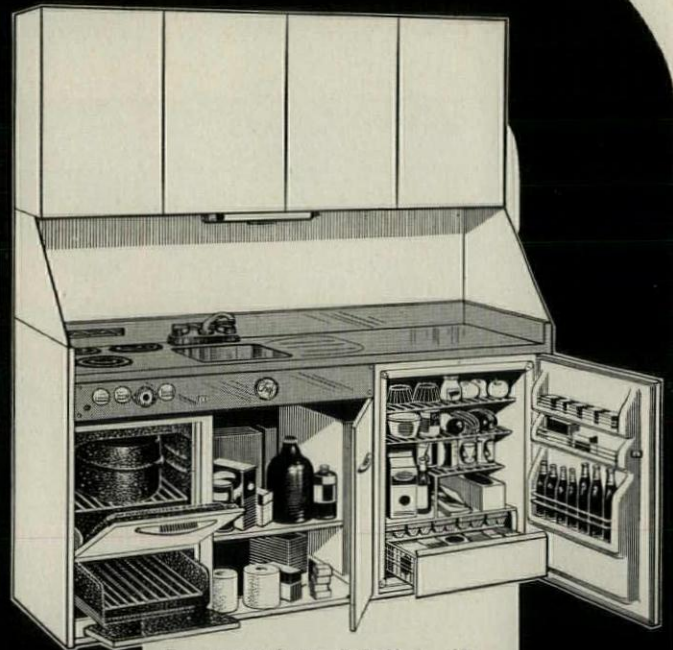

For complete details write:
General Air Conditioning Corp.
Dept. G-17, 4542 E. Dunham St.
Los Angeles 23, California

GENERAL CHEF

World's largest-selling
COMPLETE KITCHEN UNIT

IF YOU FASTEN TO, DRILL, OR CUT CONCRETE and STEEL...



Split-Second "Nailing" To Concrete or Steel with OMARK DRIVE-IT Tools.



No-Burn Stud Welding with OMARK-GRAHAM Stud Welding System.

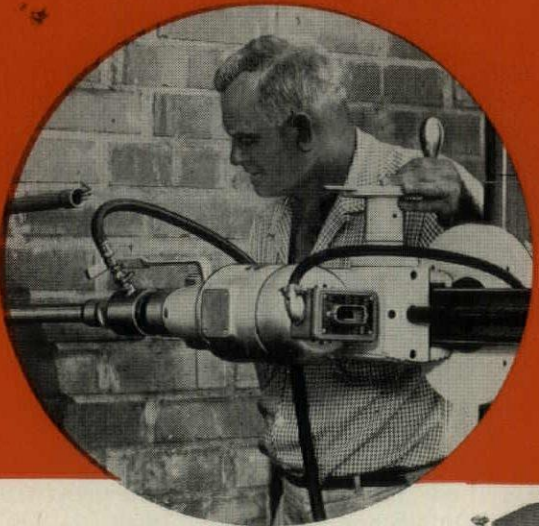

Drilling, Sawing Concrete, Masonry with OMARK Diamond Saws, Drills.



CAN DO THE JOB FASTER, EASIER AT MINIMUM COST

Whether you fasten to concrete or steel, drill or saw concrete or masonry, there's an OMARK tool made to help you do the job quicker, easier and at less cost.

Service, parts, supplies and repairs available nationwide through factory-trained personnel. Check your needs below and contact your OMARK dealer for details, demonstrations.

DRIVE-IT POWDER ACTUATED TOOLS

OMARK DRIVE-IT tools use cartridges to drive hardened steel drivepins directly into concrete or steel . . . no drilling, power lines, or plugs. Fastenings withstand thousands of pounds pullout force. Simple and safe to operate. Used by electricians, general contractors, heating, ventilating men, acoustic contractors and other building tradesmen.

OMARK-GRAHAM STUD WELDING SYSTEM

For permanent installation of insulation to metal buildings, sheet metal ductwork, tanks, boilers use the OMARK-GRAHAM stud welding system. Easy, simple to use. Needs only 115 volt power line. Welds pointed pins to many types of metal, without burn-through or distortion, for attaching insulating material. No flux, ferrules or special material preparation needed.

OMARK DIAMOND DRILLING, SAWING TOOLS

You can bore through concrete, brick, tile and masonry easily with an OMARK diamond drilling machine. Operates at any angle, drills holes from 1/4" to 18" in diameter. For sawing concrete slabs, choose one of four models of gasoline engine OMARK concrete cutters. Cut up to 12 ft. per minute. For sawing tiles, bricks, concrete blocks use an OMARK Diamond masonry saw. Zip through the largest block in one pass.

Remember, for concrete and steel fastening, drilling, sawing equipment, consult your OMARK dealer for high quality tools, dependable service.

© Copyright 1960 by

OMARK Industries, Inc.

9701 S. E. McLoughlin Blvd., Portland 22, Oregon

Branch Offices: Westwood, Mass.; Baltimore, New York, Miami, Tampa, Orlando, New Orleans, Mobile, Cincinnati, Milwaukee, Dallas, St. Louis, Chicago, Los Angeles, San Francisco.



National Bank of Detroit
Albert Kahn Associated Architects & Engineers, Inc.
Bryant & Detwiler, Gen'l Contractor

Impressively modern...

**and served by HAUGHTON OPERATORLESS ELEVATORS
... new concept in elevating inspired by Elevonics***

A dramatic combination of architectural beauty and functional design, the new National Bank of Detroit has the most advanced system of electronically controlled elevators, keyed to the age of automation!

Seventeen Haughton Operatorless Elevators speed traffic from floor-to-floor, in regal comfort, and with uncanny speed and smoothness. They are motivated by an amazing "electronic brain" that anticipates service needs at every moment, and dispatches cars at proper times and in proper sequence to meet traffic needs *exactly!*

Such is the magic of Haughton Elevonics*, key to new advancements in elevator technology... and new standards of elevator performance, economy and comfort for multi-floor buildings of all types.

We are proud that Haughton Elevators have a part in maintaining the functional integrity of the new National Bank of Detroit. Their complete reliability is thoroughly recognized by building professionals. We will be glad to furnish you with complete information on Haughton design, modernization and maintenance capabilities.

**Haughton's advanced program in elevator systems research and engineering, with specific emphasis on the creative application of electronic devices and instrumentation for betterment of systems design and performance.*

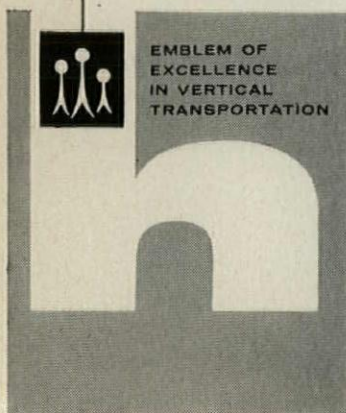

**HAUGHTON
ELEVATOR COMPANY**

DIVISION OF TOLEDO SCALE CORPORATION
Executive Offices and Plant • Toledo 9, Ohio
FACTORY BRANCHES TO SERVE YOU COAST TO COAST

NEW LOF
CURTAIN-WALL
BUILDING
STRUCTURALLY
SEALED
WITH
INLOCK[®]
NEOPRENE
GASKETS

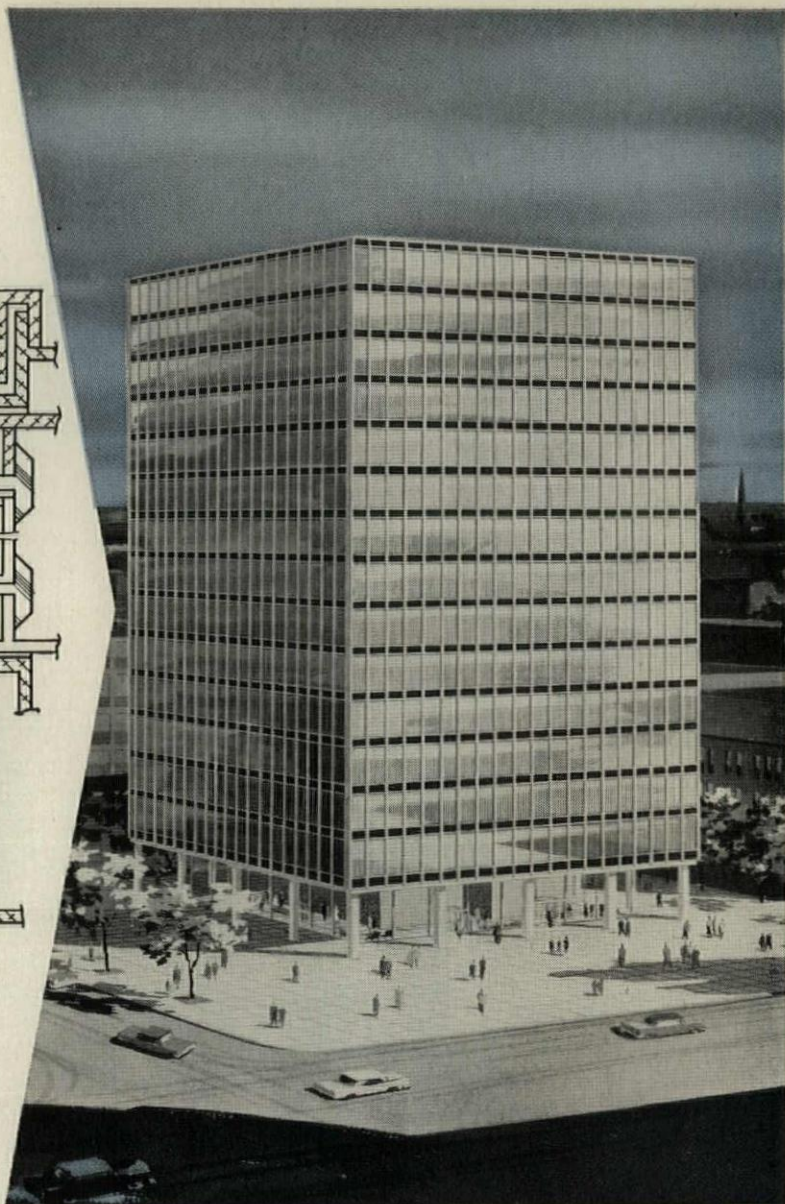
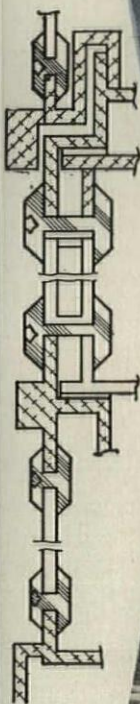

Architect: Skidmore, Owings & Merrill, New York • Contractor: The George A. Fuller Co., New York
Glazing Contractors: The Toledo Plate and Window Glass Co., Toledo—Abbott Glass Co., New York

The new, high-rise, 15 story Libbey-Owens-Ford Office Building in Toledo, Ohio, used Inlock Neoprene Structural Gaskets throughout for a resilient and leakproof setting of all window and spandrel components of its curtain-walls.

A striking showplace for L-O-F glass products, this new building has 1120 one inch Thermopane units, with Parallel-O-Grey outside panes, for fixed windows structurally sealed with Inlock Section 759228, and 1200 complementary 1/4" grey Vitrolux spandrel panels, positively sealed with Inlock Section 760161.

The first high-rise building in the world to utilize structural gaskets, the L-O-F Office Building reflects the proven advantages and functional characteristics of Inlock Gaskets. An Inlock closure system offers the owner, architect, contractor, fabricator, and glazier the ultimate in economy of installed cost and in guaranteed—long life—leakproof curtain-wall design.

The use of Inlock Gaskets reduces the technique of glazing to an exact science, thus eliminating any possibility of man failure during installation. We invite you to

investigate right now the very real savings on installation and maintenance costs.

Inlock functional designs are patented, cannot be copied or duplicated—our designs and quality may be imitated but never equalled. Tell us your sealing problems. We will design a gasket to solve it. Send for latest Catalog No. 200, showing available Inlock sections, design features, and specification data. Write Inland Manufacturing Division, 2744 Inland Avenue, Dayton 1, Ohio.

Specify . . .

INLOCK[®]
NEOPRENE
STRUCTURAL GASKET



INLAND MANUFACTURING DIVISION
General Motors Corporation, Dayton, Ohio

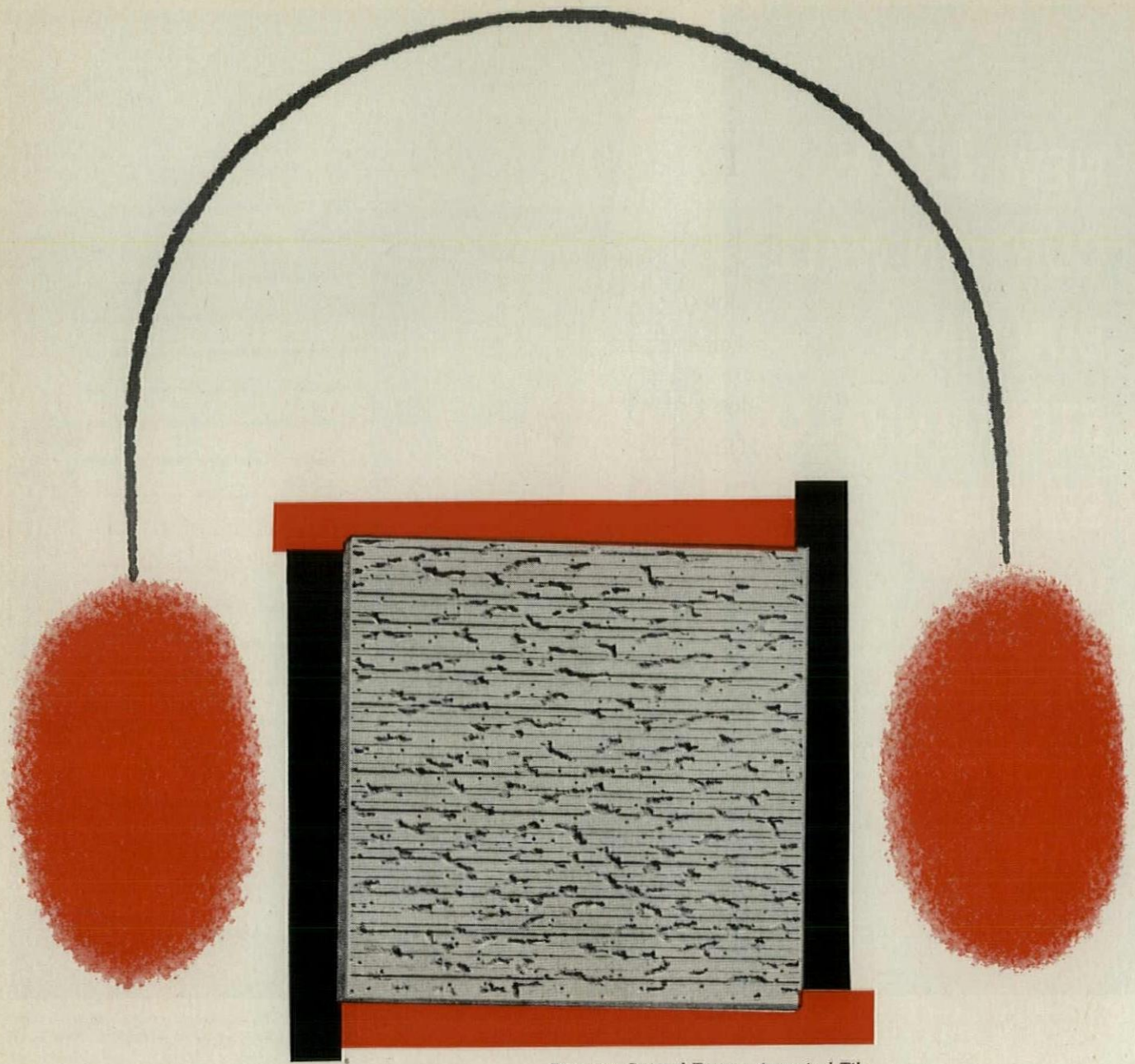

Forestone Striated Texture Acoustical Tile

SUDDENLY IT'S QUIET!

The noise you never hear is absorbed by Forestone*. This handsome woodfiber acoustical tile helps keep modern interiors quiet and beautiful. Forestone has high sound absorption characteristics and meets Class C requirements of Federal Specification SS-A-118b...exclusive Biotox processing protects it against termites, mildew and mold. Forestone is available in four distinctive deep-etched textures for all types of installations including ceiling boards for grid systems. Refer to Sweet's File or call your Simpson Certified Acoustical Contractor (look under Acoustical Materials in the Yellow Pages) for full information, or write Simpson, 1009D White Bldg., Seattle.



Forestone. quiets rooms . . . beautifully

RELY ON SIMPSON • QUALITY SINCE 1895

SAC-05/3449-*Reg. U. S. Pat. Off.-U. S. Pat. No. 2,791,289

style is stainless steel

Stainless Steel is the only surfacing material with a hard lustrous finish that is always in style, withstands exposure to all kinds of wear and has a low maintenance cost for the life of the building.

No other metal offers the freedom of design and fabrication, economy of care and the durable beauty that serves and sells like Stainless Steel.

McLOUTH STEEL CORPORATION, Detroit 17, Michigan



specify

McLOUTH STAINLESS STEEL

HIGH QUALITY SHEET AND STRIP

for architecture

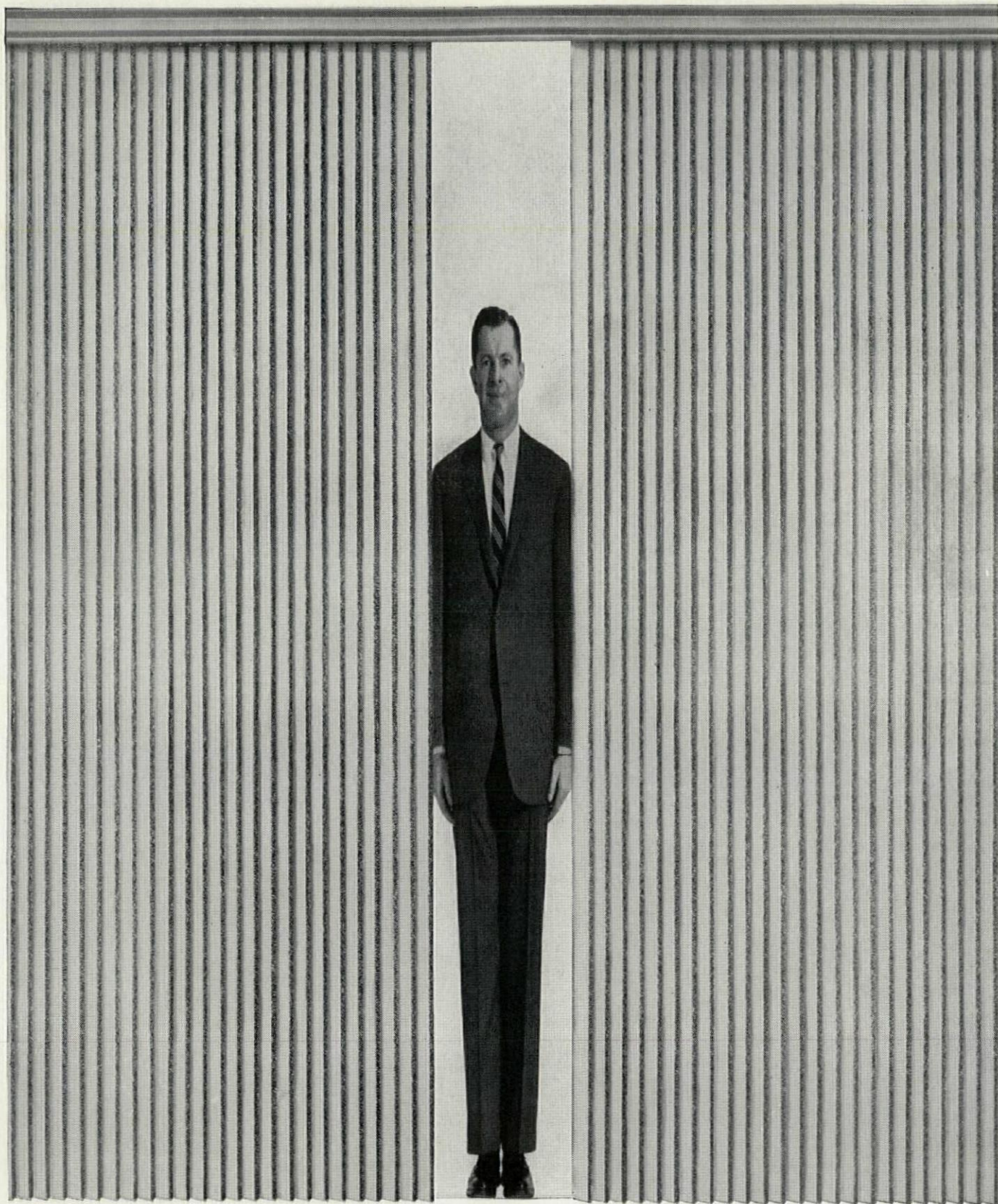

architects and designers go vertical

Flexalum Verticals give windows the bold new vertical look — dramatize them *outside* and *inside* by adding height. A single cord rotates the louvers to any angle, opens or closes the verticals for full range of light control or privacy. Dust can't cling to the vertical surfaces, so maintenance headaches don't exist. Choose from 11 Brush-Stripe, 35 solid and texture patterns in standard 2" wide louvers. Extra-wide 3½" louvers also available for large commercial installations. For name of your nearest Flexalum Verticals manufacturer write: Bridgeport Brass Co., Hunter Douglas Division, Bridgeport 2, Connecticut.

Flexalum[®] VERTICALS

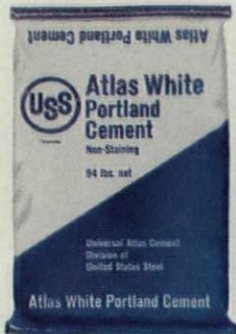

Precast concrete panels face Denver's tallest building

Denver's First National Bank Building is faced with over 100,000 square feet of precast white concrete panels. All panels were made with ATLAS WHITE portland cement and Georgia white marble aggregate. Ground to a smooth finish to expose the aggregate, the panels provide a beautiful, weathertight curtain wall that requires little or no maintenance. Positioned by overhead cranes, individual panels were bolted to the framework in record time. For example, 2 masons anchored the 900-lb. flat facing panels at the rate of one every 2 minutes. This kind of installation economy and the design versatility of precast concrete panels are becoming important considerations in constructing today's buildings. Precast concrete units can be specified in any shape, size, color or texture. For specific information on the use of ATLAS WHITE cement in architectural concrete, write Universal Atlas Cement, 100 Park Avenue, New York 17, N. Y.

"USS" and "Atlas" are registered trademarks

WF-48



**Universal Atlas Cement
Division of
United States Steel**

OFFICES: Albany • Birmingham • Boston • Chicago •
Dayton • Kansas City • Milwaukee • Minneapolis •
New York • Philadelphia • Pittsburgh • St. Louis • Waco



FIRST NATIONAL BANK BUILDING, DENVER, COLORADO — **Architect:** Raymond Harry Ervin & Assoc., Denver; **Engineer:** Phillips-Carter-Osborn, Inc. and Rhuel A. Andersen; **Gen'l Contractor:** Mead & Mount Construction Co., Denver; **Concrete Panels:** Otto Buehner & Co., Salt Lake City.

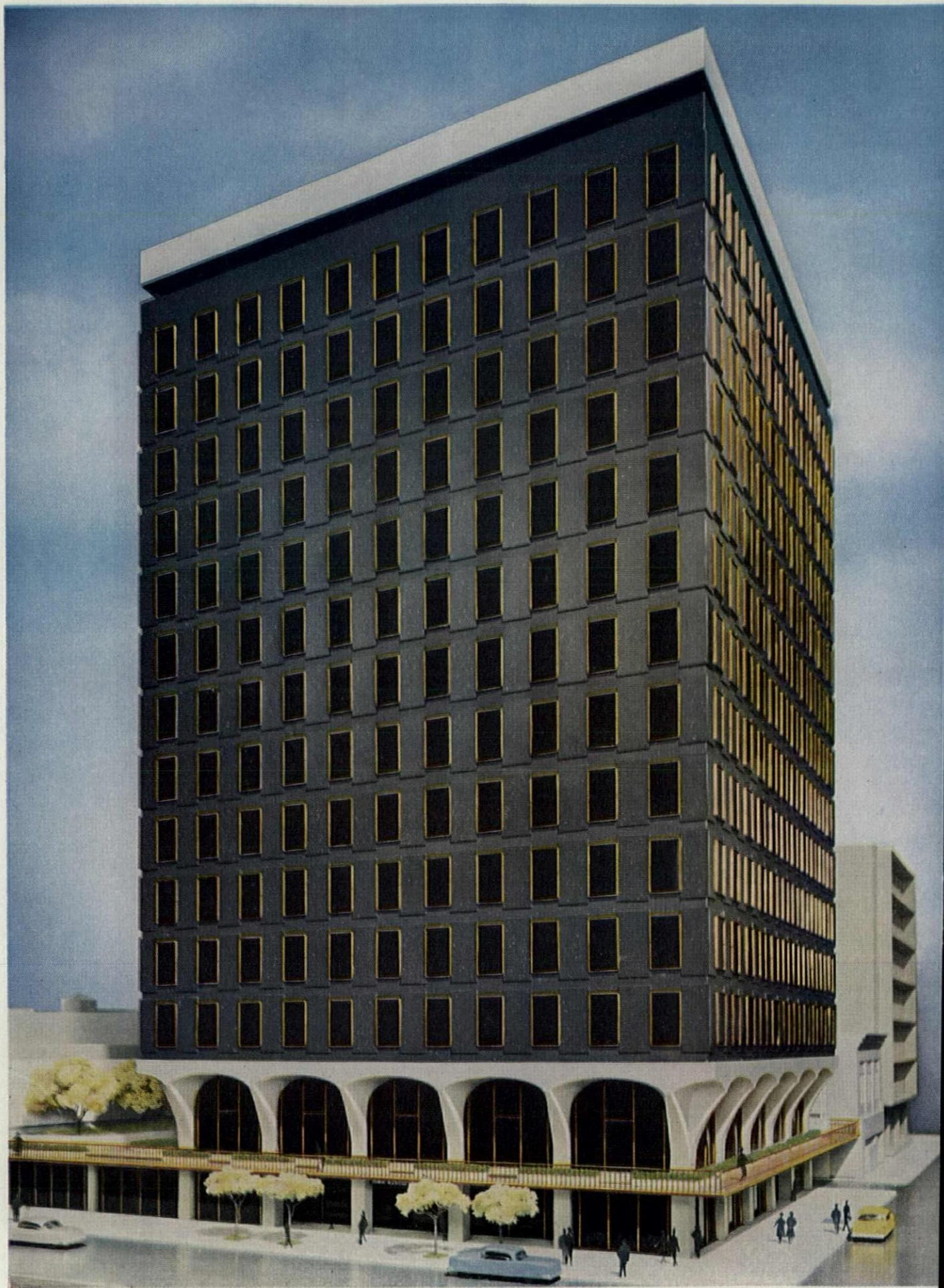

NEW BRONZE BEAUTY BY THE GOLDEN GATE

New San Francisco Western Home Office of John Hancock Life features functional use of Chase® Architectural Bronze

The John Hancock Mutual Life Insurance Company wanted a new warmth, beauty and elegance in their Western Home Office building. They turned to the beauty of bronze.

Each of the 528 window frames for the new building is of Chase® Bronze...special architectural shapes for frames and glass stops that hold the hundreds of panes in place. These interlocking elements require tolerances which are reassured to thousandths of an inch.

Bronze has other important uses. An all-bronze railing encircles two sides of the building at the second floor. Window flashings are Chase copper. When this new 15-story building is occupied in the fall, the functional use of Chase bronze will add new beauty and distinction to the downtown skyline in San Francisco.

Call your nearest Chase office, or write Chase at Waterbury 20, Conn. for the help of expert Chase metallurgists.



Chase

BRASS & COPPER CO. WATERBURY 20, CONN.
Subsidiary of **Kennecott Copper Corporation**

THE NATION'S HEADQUARTERS FOR ALUMINUM • BRASS • BRONZE • COPPER • STAINLESS STEEL

Atlanta Baltimore Boston Charlotte Chicago Cincinnati Cleveland Dallas Denver Detroit Grand Rapids Houston Indianapolis Kansas City, Mo. Los Angeles Milwaukee Minneapolis Newark New Orleans New York (Maspeth, L. I.) Philadelphia Pittsburgh Providence Rochester St. Louis San Francisco Seattle Waterbury

CHASE SALUTES: Skidmore, Owings & Merrill, Architects, San Francisco • Lawrence Halprin, Landscape Architect • Cahill Brothers, Inc., General Contractors • C. E. Toland & Sons Ornamental Metal Fabricators.

WINDOWS and exterior doors on all floors of the new Hancock building feature the use of Chase Architectural Bronze Shapes, made to tolerances of thousandths of an inch. Bronze adds warmth, beauty and elegance to the building.

BALCONY around two sides of building has a beautiful bronze railing made of Chase Architectural Bronze. This feature adds beauty to the new building now under construction at California and Battery Streets in San Francisco.

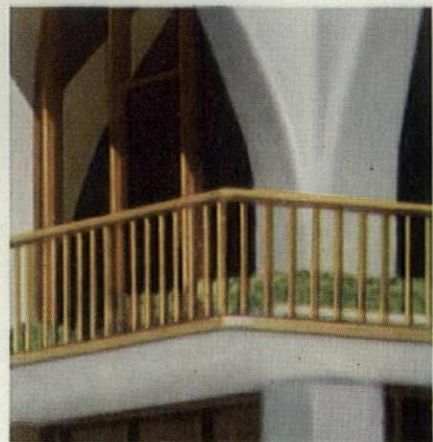
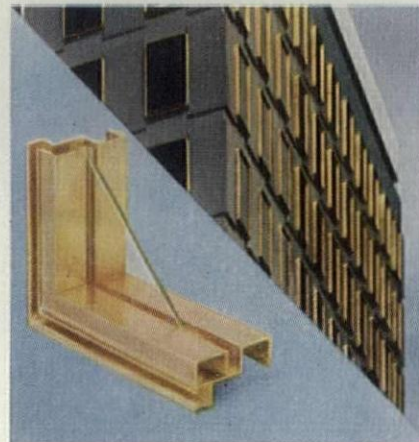



PLEXIGLAS letters and modular background panels at Bank of Old York Road, Abington, Pa. Architects: Haag & d'Entremont

BEST WAY TO SIGN A NAME ...

PLEXIGLAS

Powerful identification can be combined with pleasing, dignified appearance when signs are made of PLEXIGLAS® acrylic plastic.

Designed in PLEXIGLAS, signs become solid areas of color and light—clean and legible by day, completely luminous from internal lighting at night. They resist weather and breakage, cost little to maintain. PLEXIGLAS makes possible the design of signs that meet the specific identification needs of any type of business, any type of building.

We will be glad to put you in touch with sign companies in your area who are experienced in the use of PLEXIGLAS.



Chemicals for Industry

**ROHM & HAAS
COMPANY**

WASHINGTON SQUARE, PHILADELPHIA 5, PA.

In Canada: Rohm & Haas Company of Canada, Ltd.,
West Hill, Ontario

*weather-tight with
corner-molded
Climatite*

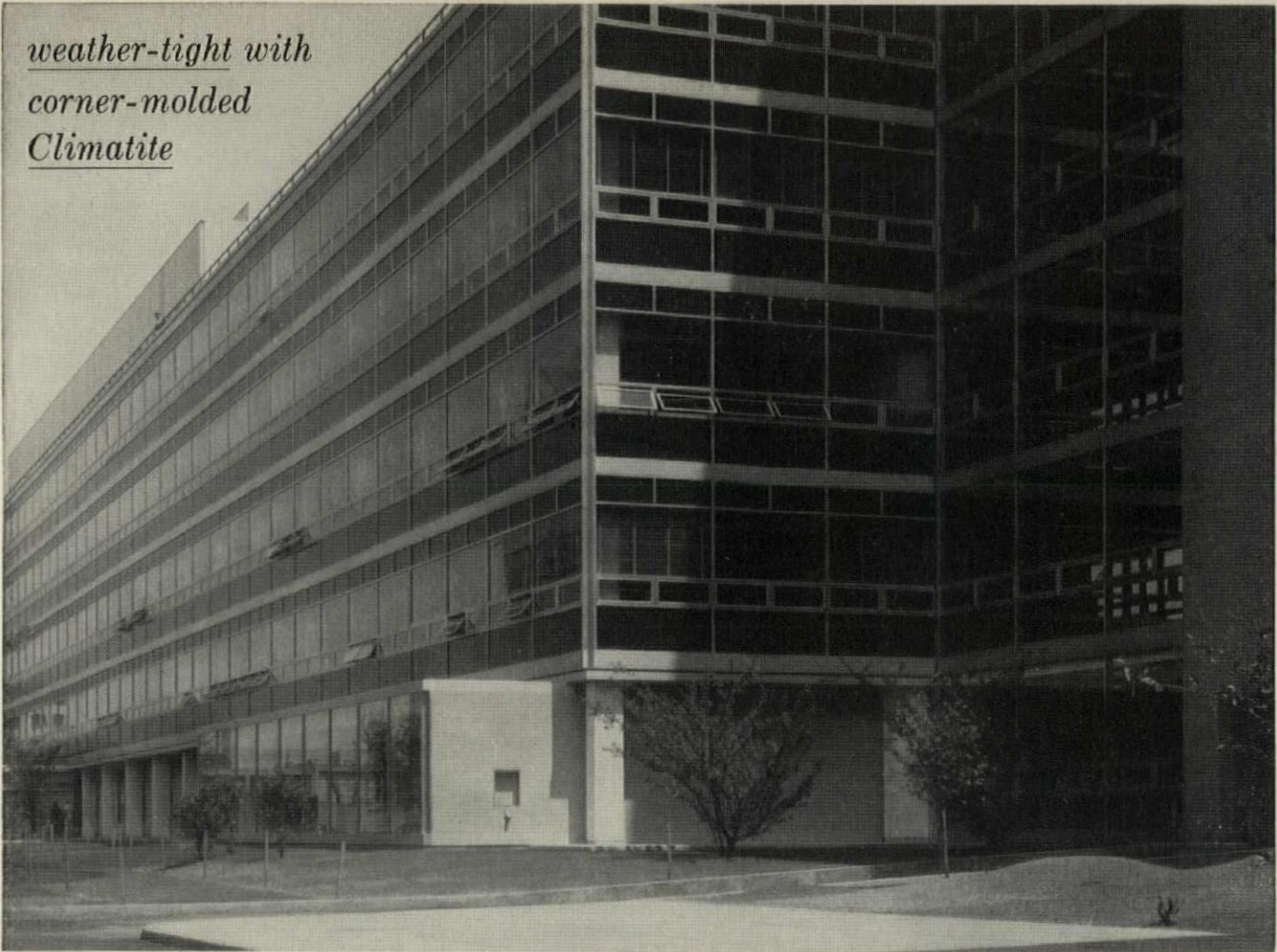

ONE OF THE LABORATORY BUILDINGS AT M.I.T. Architects: Skidmore, Owings & Merrill; Geo. Fuller, contractor and builder.

FIRESTONE CLIMATITE PANEL GASKETS SEAL OUT WATER AND WEATHER FOR A STRUCTURAL LIFETIME

This striking M.I.T. laboratory building in Cambridge, Mass., features a weather-impregnable sealant for curtain walls—*Firestone Climatite Panel Gaskets*.

These are one-piece channel gaskets *molded to fit* at all corners without buckling, sagging or cracking. Their custom-made compounds are *precisely* formulated for maximum resistance to area climatic conditions. Result: lasting weather tightness—so much so that the gaskets unflinchingly withstand repeated 140-m.p.h. water/wind machine tests without a leak.

Another *Climatite* product much in demand is *Climatite* adhesive strip-seal, a perennial best seller for its stout protection against the elements.

Use the coupon or call today for complete details on this sound building investment for your clients and for yourself.

Copyright 1960, The Firestone Tire & Rubber Company

Firestone
RUBBER & LATEX PRODUCTS CO.

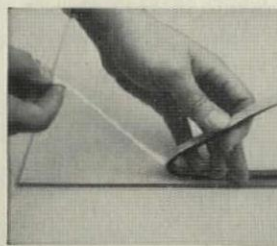

CLIMATITE adhesive strip-seal is a builders' favorite for its ease of installation and exceptional weather resistance.



CLIMATITE channel gasket molded-to-fit corners eliminate buckling, sagging and cracking. A lasting seal at every edge.

FIRESTONE RUBBER & LATEX PRODUCTS CO., FALL RIVER, MASSACHUSETTS

Gentlemen:

CLIMATITE'S unique advantages interest us. Please send detailed information, including cost. Please have your representative call and demonstrate CLIMATITE, with no obligation to us.

NAME _____

FIRM _____

ADDRESS _____

CITY _____

ZONE _____

STATE _____

FBP 16 (1)



MAHON CURTAIN WALLS

IN NATURAL OR COLORED METALS

**provide an ideal combination—
high design potential...
low-budget installation**

Mahon Curtain Walls of charcoal-gray enamel are functionally and attractively used in this new motel at Plymouth, Mich., General Contractor: Don Primo Co.

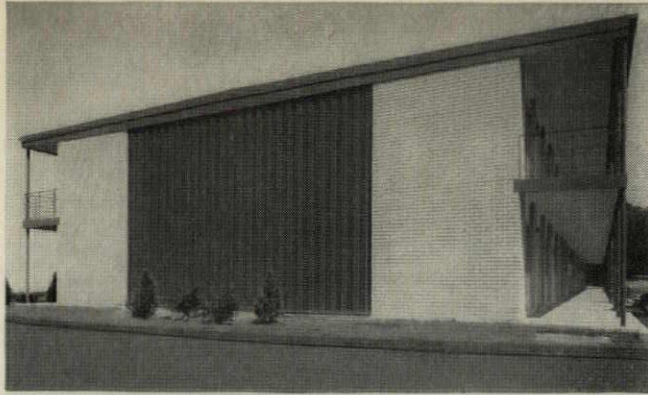

Even used with dissimilar building materials (as shown in this rear view of the Hines Park Motel) Mahon Curtain Walls integrate easily for modern design expression.

The design flexibility of Mahon Metal Curtain Walls gives you a practical answer to many architectural and construction problems. Walls for the long runs of a giant industrial plant . . . for the touch of individuality in small commercial buildings or for the vast sweep of modern, multi-story buildings . . . exterior walls that glisten in clean metal or glow in dynamic color . . . walls that decorate, protect and solidify. Mahon Curtain Walls will meet your every requirement. They can be erected up to 60 feet in height without a horizontal joint . . . vertical joints are invisible. Quality Metal Walls from Mahon cost no more when specified nor do savings stop with installation—maintenance is low, durability is long. To learn how Fiberglass-insulated Mahon Curtain Walls fit into your project, contact your local Mahon representative, write for descriptive catalog or see Sweet's Files.

MAHON BUILDING PRODUCTS

- Aluminum or Steel Curtain Walls (in natural or colored metals)
- Rolling Steel Doors (Standard or Underwriters' labeled)
- Metalclad Fire Walls (Underwriters' rated)
- M-Floors (Steel Cellular Sub-Floors)
- Long Span M-Deck (Cellular or Open Beam)
- Steel Roof Deck
- Acoustical and Troffer Forms
- Acoustical Metal Walls, Partitions and Roof Decks
- Permanent Concrete Floor Forms

CONSTRUCTION SERVICES

- Structural Steel-Fabrication and Erection
- Steel Fabrication-Weldments

RIBBED
—field constructed

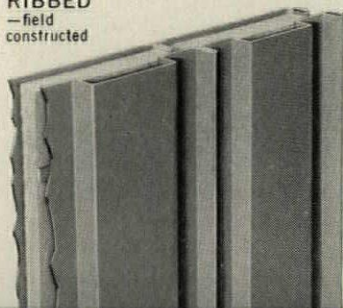

FLUTED
—field constructed

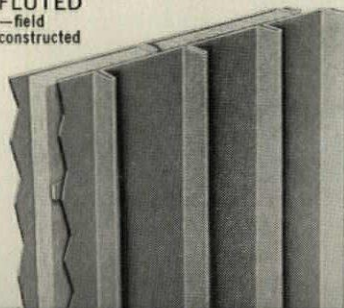

FLUSH or FLUTED
PREFAB PANELS

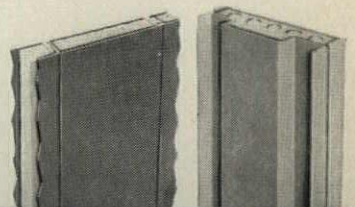

Mahon Curtain Walls are supplied in galvanized, porcelainized, enameled or stainless steel, and aluminum in many finishes, each in three types

THE R. C. MAHON COMPANY / DETROIT 34, MICHIGAN

Manufacturing Plants—Detroit, Michigan and Los Angeles, California.
Sales-Engineering Offices in Detroit, New York, Chicago, Los Angeles and San Francisco.
Representatives in all principal cities.

SPEEDING AMERICAN CONSTRUCTION WITH METAL BUILDING PRODUCTS, FABRICATED EQUIPMENT AND ERECTION SERVICES

MAHON

**LOW COST, WHITE
ROOFING AGGREGATE**

CRYSTALITE

**Bondable, Whitest White
Highly Reflective Marble**
(cuts air conditioning expense)

Sparkling white Crystalite makes a beautiful built-up roof—yet costs very little more than the cheapest aggregates. Crystalite is approved for bonding by leading roofing material manufacturers. Crystalite is a hard, nonporous limestone marble.

It will not crumble, deteriorate or change color. Because of its heat reflective properties, air conditioning expense is greatly reduced. Crystalite, clean, dry and ready to use, also saves on handling expense.

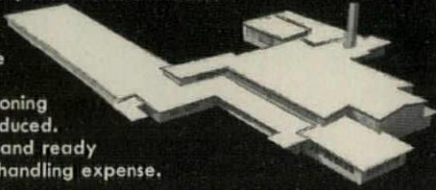

Write for Complete Information, Samples and Prices
BLACK WHITE LIMESTONE CO.
Front and Eighth Streets, Quincy, Illinois

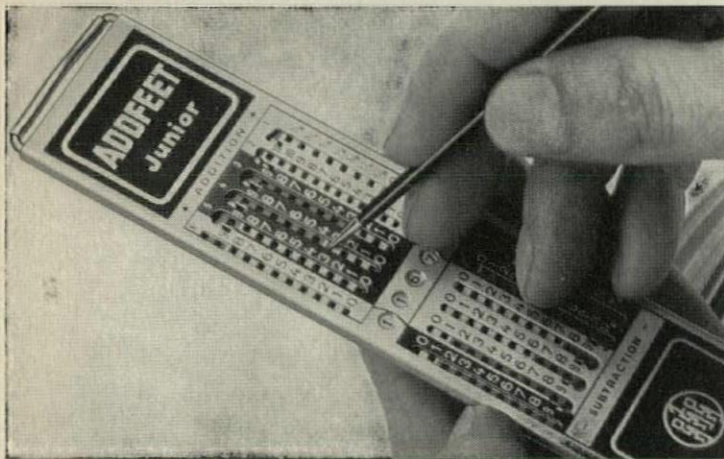

PRECISION POCKET CALCULATOR

**ADDS AND SUBTRACTS FEET, INCHES and FRACTIONS to 1/8ths;
CONVERTS FRACTIONS INTO INCHES, INCHES INTO FEET
AUTOMATICALLY!**

Costs only \$4.95

Invaluable aid to architects, engineers, draftsmen, etc.

- Saves time; 2 to 3 times faster than mental arithmetic.
- Eliminates costly errors.
- Simple to use, impossible to use incorrectly.
- Adds and subtracts to 9,999 feet, 11 7/8 inches.
- Embossed numbers for long life, easy reading.
- Only 1 1/2" wide x 6" long x 3/16" thick, easily fits pocket.
- Comes complete with genuine leather case, new illustrated booklet.
- Fully guaranteed for one year.
- 10 day money-back trial period.

Send check or money order to

Sole U. S. Agent: **Alexander Drafting Equipment Co.**
642 North Chester Avenue, Pasadena, California

Add 4% Sales Tax in California

ADDFEET—A precision-made product of West Germany. Dealer inquiries invited. Exclusive agents for Canada wanted.

Competitively priced *PARAGON* projected aluminum *WINDOWS*



Swing **2** BIG BENEFITS YOUR WAY

DESIGN: Aluminum beauty . . . clean functional lines that are adaptable to any styling plus the rugged strength of heliarc welded construction. Inside bead glazing . . . white bronze hardware standard.

FUNCTION: Ideal ease of operation and practical draft control settings . . . easily positioned on nylon shoes under spring tension . . . weather tight closure with single plane polyvinyl seal.

PLUS THIS BIG BONUS: Paragon windows are competitively priced. A heavyweight sturdy window in the medium price range, Paragon offers many fine construction features usually found only in costlier windows at prices lower than those charged for some makes of lesser quality.

Feel sure that you're giving your client the best. Specify Paragon! Here is a projected aluminum window ideal for hospitals, schools, offices, public buildings and commercial installations of all kinds. You can have Paragon Windows in special sizes and arrangements for single or multi-story curtain walls. Bids will be submitted for *prompt delivery* on either large or small orders. Engineering consultation is available to architects with no obligation. For information write:

PETERSON WINDOW CORPORATION
706 Livernois Avenue, Ferndale 20, Michigan

COLORLINE[®]

PARTITIONS



*National Society for Crippled Children and Adults, Chicago, Illinois
Reception Lobby and Directors Room (below) in National Headquarters*

Designed by Walter E. Foss
with J. William Iid as Architect



Just a pencil and your imagination

are all it takes to design a COLORLINE interior. You need no catalog of "standard" wall units at hand . . . because COLORLINE partitions are a way of creating interiors, not a way of buying them. With the COLORLINE system, you can think big at low cost . . . combine shapes, sizes, colors, patterns, textures as you will. Our full color brochure may give you some new ideas about space division. Write

Unistrut Products Company,

931 West Washington Boulevard, Chicago 7, Illinois.

SEE US IN "SWEETS"

FREEDOM OF FORM

The artist knows which materials allow the sculptor's curve, a clean interplay of line, a precise, geometric mass, or a shaggy, romantic texture. This is freedom; freedom which fits into a structural frame or holds up the roof; freedom, too, through economy and ageless workmanship. This is brick and tile.

ARTISTS AND THEIR WORKS:

Jefferson Medical College Hospital,
Vincent Kling, Architect.
Chapel, Massachusetts Institute of Technology,
Eero Saarinen and Associates, Architects.

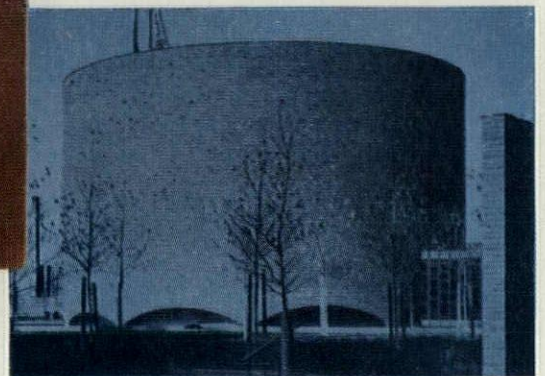
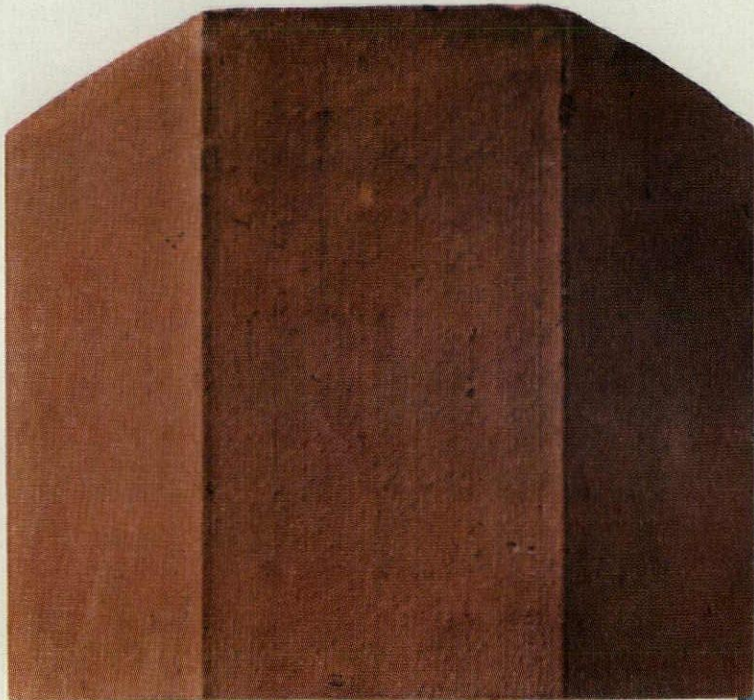
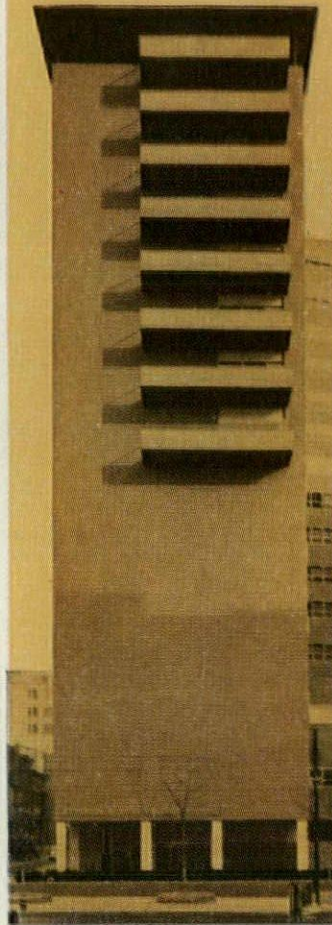

STRUCTURAL CLAY PRODUCTS INSTITUTE

1520 18th St. N.W.
Washington, D.C.

A roundup of recent and significant proposals

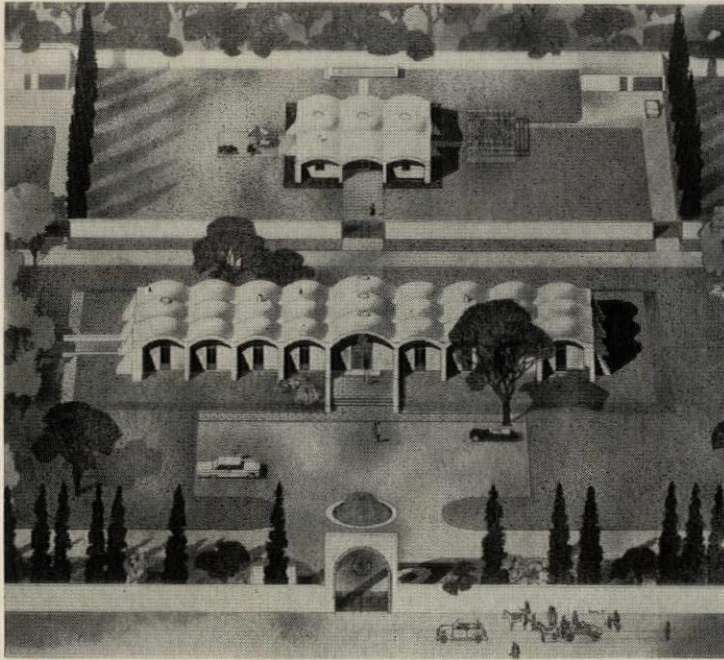

U.S. CONSULATE IN IRAN

Edward Larrabee Barnes's design for the U.S. Consulate in Tabriz, Iran, achieves a tactful blend of old and new, using building techniques and site planning indigenous to ancient Persia. The two buildings shown at left—the consul's residence (top) and an office building—will be brick, the domes and vaults built over curved brick beams without centering. Like these first two buildings, a block of staff apartments, garage and service facilities, and a recreation area will stand in separate courts, all within a walled compound entered through a main gate. Construction of the first units will start this year. Structural engineers: Severud-Elstad-Krueger Associates.



DOWNTOWN CHICAGO PROJECT

Just a block from the Loop, on the Chicago River at State Street, the Building Service Employees International Union of the AFL-CIO plans to start work next month on Marina City (right), a \$36-million development. Two 60-story apartment cylinders, a rectangular office building, and a motion picture theater (above) are the main elements in the scheme by Bertrand Goldberg Associates, but there will also be a skating rink, a marina, and a sprinkling of open space. Roughly a third of each tower will be a parking ramp so that apartments will begin at the 20th floor.

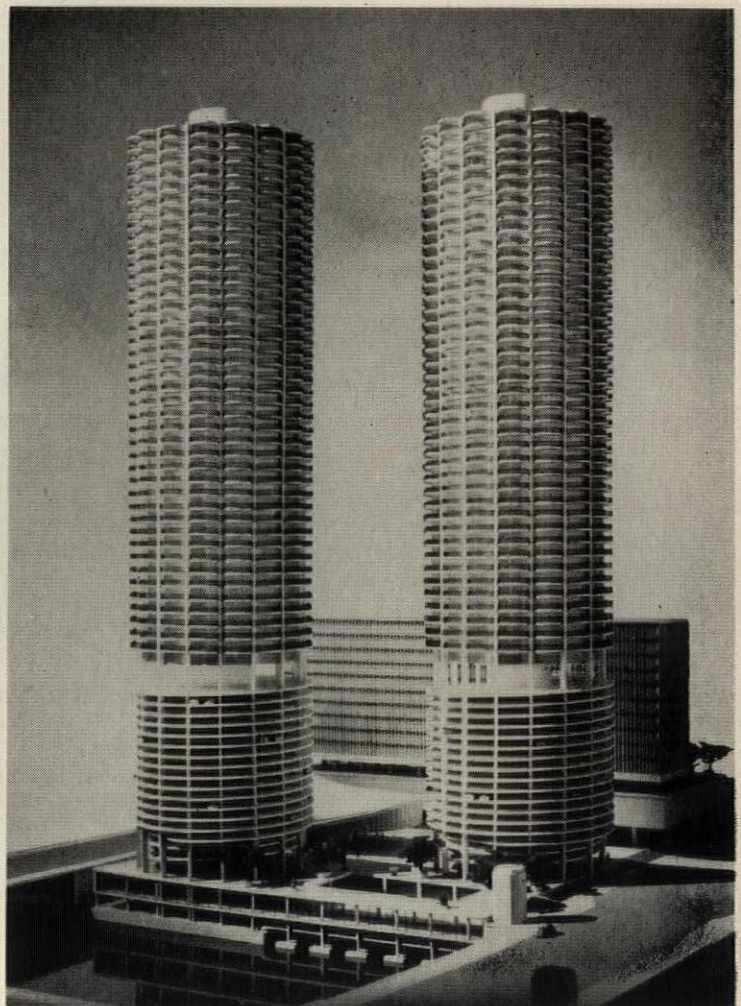

continued on page 67

No. 3 Penn Center Plaza
Philadelphia, Pa.
Architect: Emery Roth & Sons
Contractor: Cauldwell-Wingate Co.

planned
for
lowest
maintenance
with

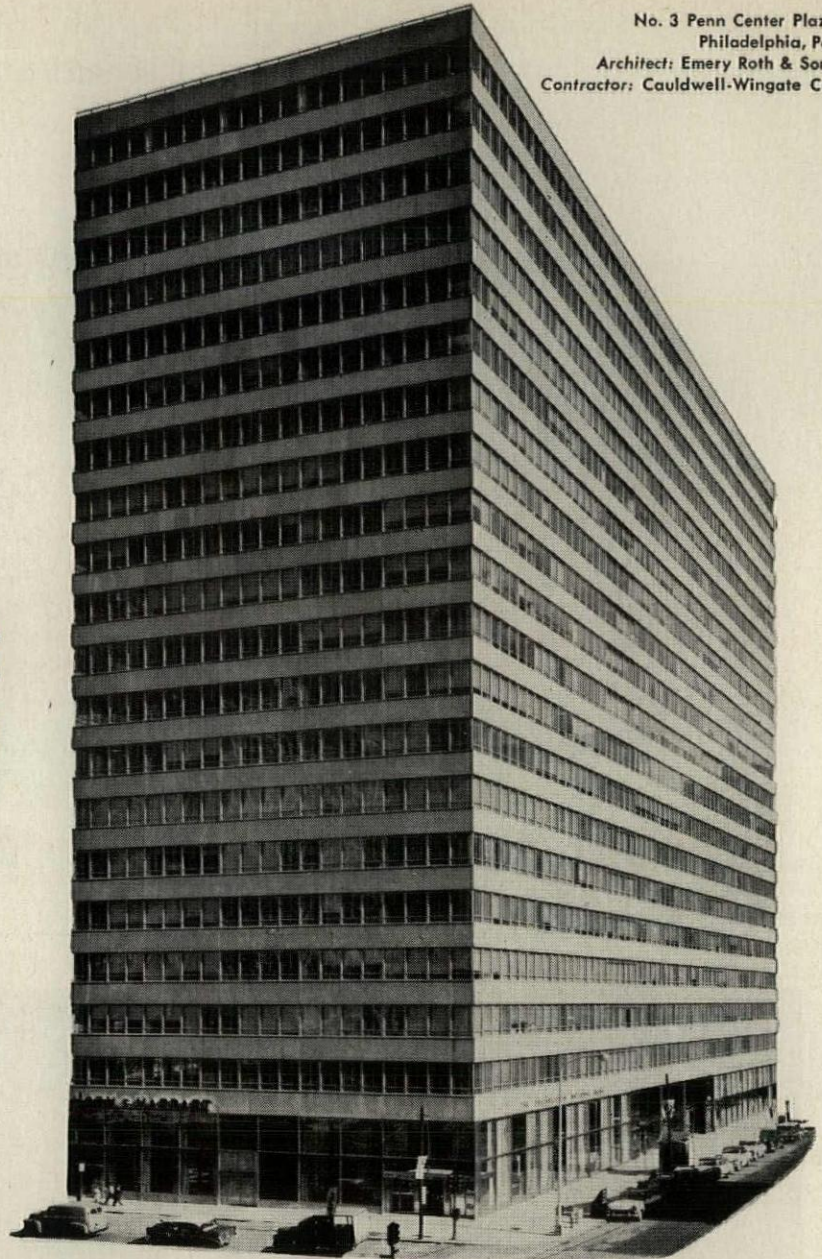

quality approved

ALUMINUM WINDOWS

**QUALITY APPROVED
ALUMINUM WINDOW**



TYPE: DH-A1 SERIES: 100
SIZE TESTED: 3'8" x 5'0" CERT. NO. 400
MANUFACTURERS NAME
CITY AND STATE

You get lowest maintenance costs when you design and build with "Quality-Approved" aluminum windows—either awning, casement, double-hung, jalousie, projected or sliding types. They are rustproof and rotproof . . . never need painting or expensive maintenance. They retain their trim modern appearance for the life of the building and save money year after year for the owner. Specify "Quality-Approved" and look for the seal on the window. For latest Window Specifications book, write to Dept. AF 604.

ALUMINUM WINDOW MANUFACTURERS ASSOCIATION, 630 Third Ave., New York 17, N. Y.

These window manufacturers are ready to supply you with "Quality-Approved" Aluminum Windows.

Adams Engineering Co., Inc., Miami, Fla. • Albritton Engineering Corp., Bryan, Texas • Aluminum & Glass Products Co., Houston, Texas • American Duralite Corp., Loudon, Tenn. • Arnold Altex Aluminum Co., Miami, Fla. • The Wm. Bayley Co., Springfield, Ohio • Capital Products Corp., Mechanicsburg, Pa. • Ceco Steel Products Corp., Chicago, Ill. • Crossly Window Corp., Miami, Fla. • Fenestra Incorporated, Philadelphia, Pa. • Michael Flynn Mfg. Co., Philadelphia, Pa. • Mayfair Industries, Inc., Lafayette, La. • Miami Window Corp., Miami, Fla. • Porterfield Industries, Inc., Miami, Fla. • Reynolds Metals Co., Richmond, Va. • F. C. Russell Co., Columbiana, Ohio • Truscon Division, Republic Steel Corp., Youngstown, Ohio • Valley Metal Products Co., Plainwell, Mich. • W. M. Products Co., Houston, Texas • Windalume Corp., Kenil, N. J. • Wisco Incorporated, Detroit, Mich.

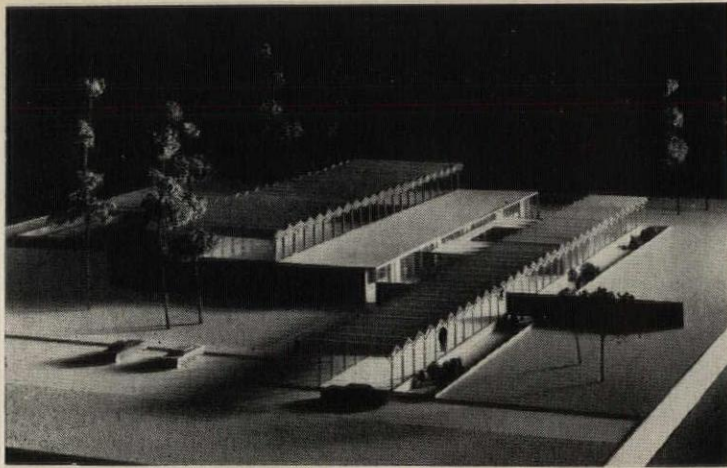

WASHINGTON LABORATORY UNDER A SERRATED WOOD ROOF

If researchers inside the Simpson Timber Co. laboratory (above) find it hard to think creatively about wood, it will not be the fault of the building's architect. Paul Hayden Kirk put his client's products to work in stressed-skin plywood panels, folded plate roofs,

and box beams for the laboratories and offices to be built on a 10-acre plot near Bellevue, Wash. Ground-breaking will take place late this spring, and the 20,000-square-foot building is expected to be ready for full operation toward the end of the year.

KANSAS CITY'S JET AIRPORT FOR 1975

Passengers skimming along underground tunnels on moving sidewalks are part of Kansas City's plans for its \$50-million air terminal in Platte County, Mo. The tunnels would connect ticket and baggage depots ringing the parking lot (center) to four

separate loading terminals. The terminals' walls will be recessed to allow jets close enough for passengers to board from escalators carrying them up to the plane's door. Architects and engineers: Cooper-Robison - Carlson - O'Brien of Kansas City, Mo.



NEW CITY IN TEXAS

Close to the city limits of El Paso, Developers Arthur Rubloff and Joseph Timan plan a whole new city (right) which, when completed, will have 1.5-million inhabitants and six times El Paso's area. The heart of Horizon City's 167 square miles will be an elliptical park and a man-made lake dividing two half-moon business and commercial sections. One end of the park would be set aside for a civic center; the other, for cultural and recreational buildings. Brazilian Lucio Costa is planning consultant to Horizon City, assisted by Nicholas Sakellar and Guy Greene.



LOS ANGELES OFFICES

In Los Angeles next month the Pacific Employers Group of five insurance companies will begin work on its new nine-story home-office building (below). Charles Luckman Associates, who designed it, moved all the service and mechanical equipment, including stairs and elevators, into an outside mechanical shaft, leaving the office floors largely unobstructed. Facing Wilshire Boulevard, the main entrance will be flanked by reflecting pools and fountains.



CHICAGO TOWN HOUSES

Eight houses, built in clusters around walled gardens (left), have been designed by Architect Y. C. Wong (owner of one house) for construction in Chicago's Hyde Park-Kenwood urban renewal area. To passers-by, the houses will present windowless masonry façades, but each family's living room and three bedrooms will face a private garden entered through sliding glass walls. These "atrium" houses, described as "inner-directed architecture," will cost \$32,500 for 2,000 square feet, including 480 square feet of garden.

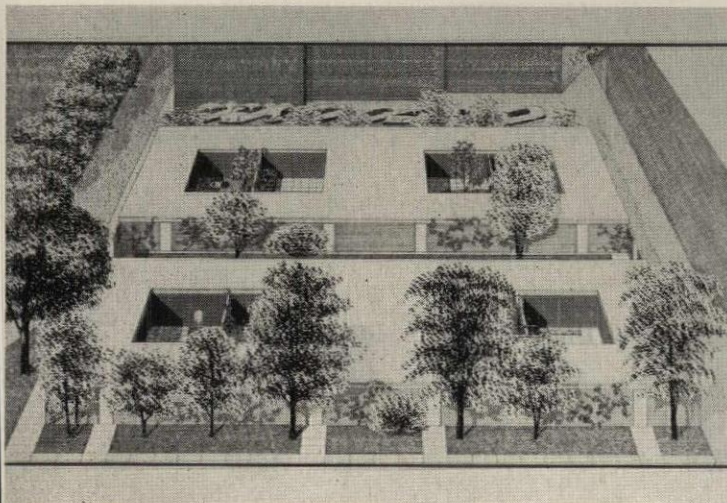

continued on page 69

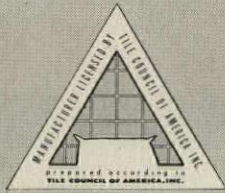

Tile Council dry-set Portland Cement mortar

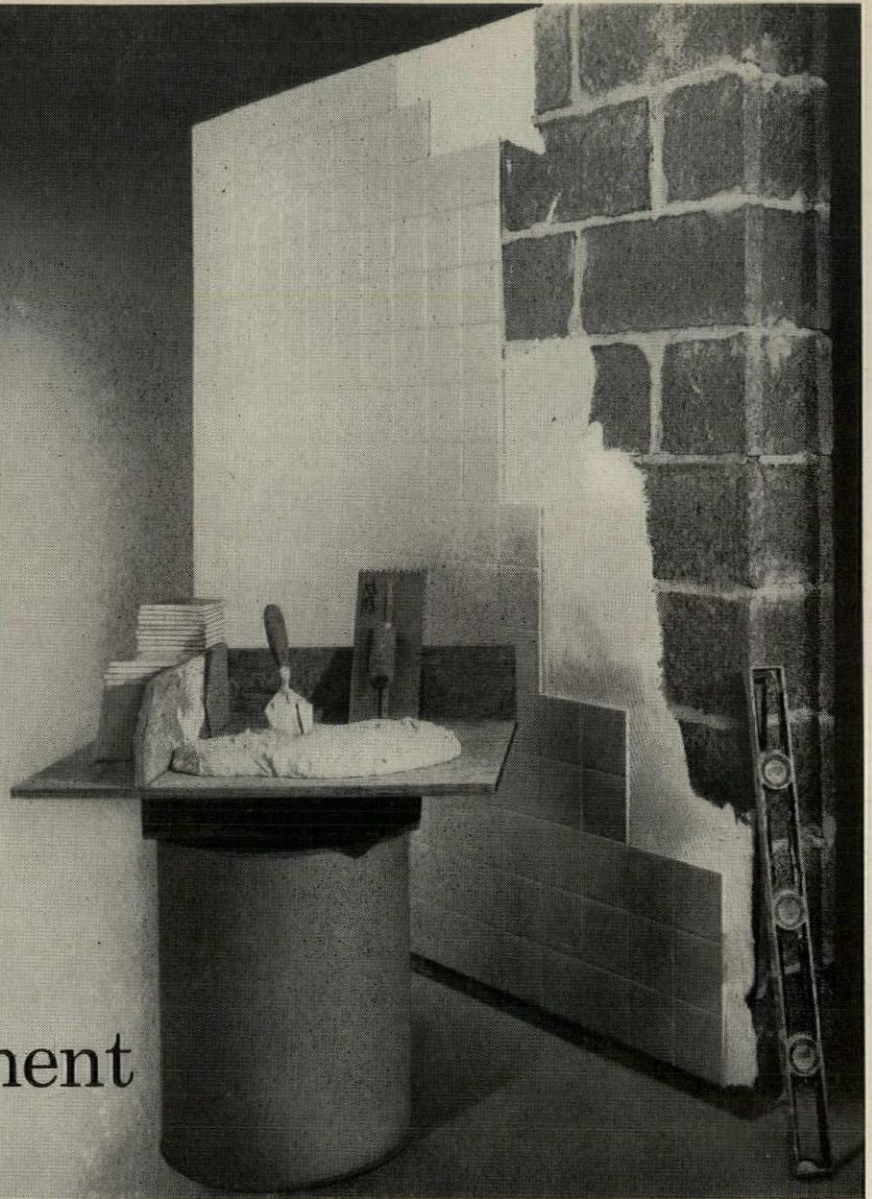

...makes a better bed...faster

The new mortar for installing ceramic tile provides the architect and builder with a better setting bed for many important applications. The new mortar has been particularly satisfactory for concrete masonry, cement plaster and poured concrete floor construction.

This new mortar reduces radically the time and labor of tile installations. It gives a bonding strength of double that of conventional types of mix. The secret: A Tile-Council-developed additive which makes Portland Cement water-retentive and gives it more tensile strength. Result: setting beds are thinner, mixing time is cut to a

minimum, tile does not have to be soaked, backup walls do not have to be sprayed and the tile mechanic finds the mortar easier to work.

The new mix is one of many developments at the Tile Council Research Center in Princeton, New Jersey. This industry-sponsored research program continues to discover new uses and better installation methods for ceramic tile.

Manufactured by L. & M. Tile Products, Inc., Technical Adhesives, Inc. and the Upco Company, the new mortar is available nationally. Look for the seal of approval.

The Modern Style is

TILE COUNCIL OF AMERICA, INC. 800 Second Ave., N. Y. 17, N. Y.; Room 933, 727 West Seventh St., Los Angeles 14, Calif.; Room 207, 5738 North Central Expressway, Dallas, Texas • American Encaustic Tiling Co., Inc. • Atlantic Tile Mfg. Co. • Aztec Ceramics, Inc. • Cambridge Tile Mfg. Co. • Carlyle Tile Co. • Continental Ceramics Corporation • General Tile Co. • Gladding, McBean & Co. • Hood Ceramic Corporation • Jackson Tile Mfg. Co. • Jordan Tile Mfg. Co. • Lone Star Ceramics Co. • Monarch Tile Mfg. Inc. • Mosaic Tile Co. • Murray Tile Co., Inc. • National Tile & Mfg. Co. • Olean Tile Co. • Oxford Tile Company • Pacific Tile and Porcelain Co. • Pomona Tile Mfg. Co. • Redondo Tile Company • Ridgeway Tile Co. • Robertson Mfg. Co. • Stylon Corp. • Stylon Southern Corp. • Summitville Tiles, Inc. • Texeramics, Inc. • Wenzel Tile Co. • Winburn Tile Mfg. Co.

CERAMIC
tile

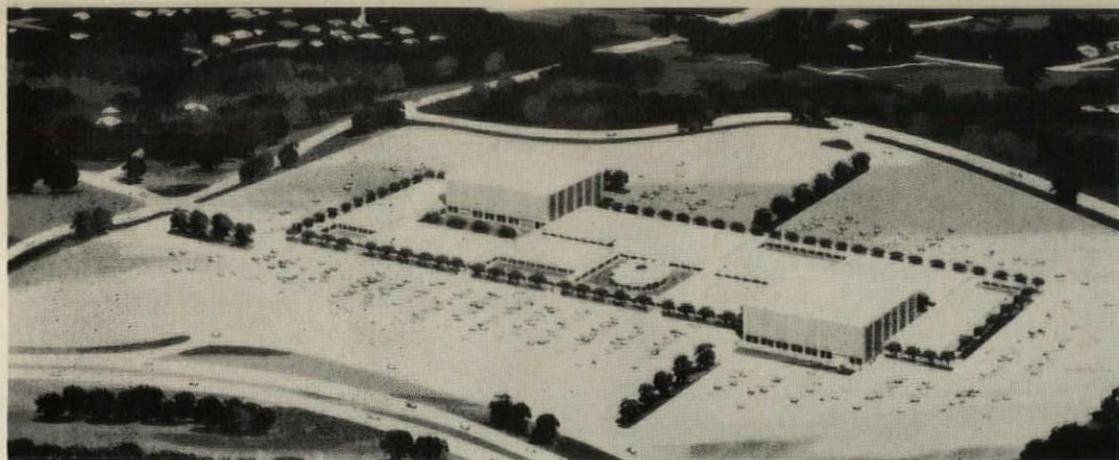

SHOPPING CITY IN ATLANTA

A \$12-million shopping center in southwest Atlanta will be strategically located at the intersection of two major highways and bordering a new 300-home subdivision. Since the shopping and residential areas are going up simultaneously, the developers call their venture a shopping city. The developers are Trammel Crow and W. R. Hawn of Dallas and John C. Portman Jr., whose architectural firm, Edwards & Portman, designed the shopping city.

VIRGINIA CIVIL WAR CENTENNIAL DOME

Civil War buffs interested in the Army of Northern Virginia will be drawn to Richmond during the centennial years. There the Virginia Civil War Commission will erect an aluminum dome over three-dimensional exhibits, memora-

bilia, and short films relating to the campaigns. Walter Dorwin Teague Associates designed the centennial building, which will rest on limestone or cast stone piers. A ramp will lead visitors inside and wind around the dome's perimeter.

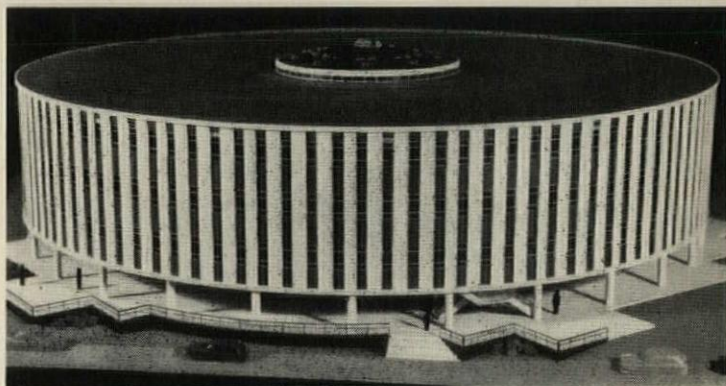
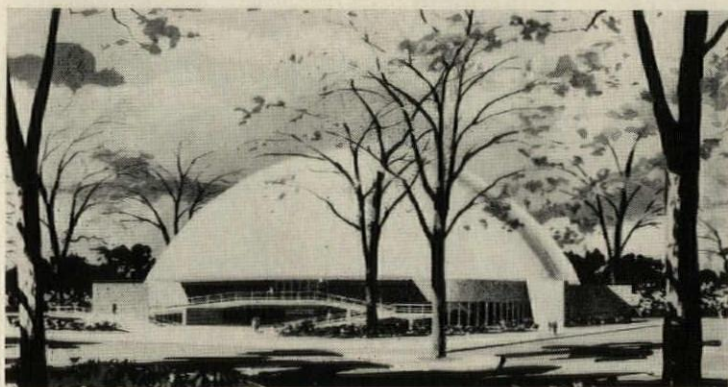

A DRUM FOR 6,000 NORTH CAROLINA STUDENTS

Perched on stilts, this huge striped drum is a general classroom building under construction in the center of the North Carolina State College campus, Raleigh. Each of its three floors will resemble a soup plate: offices on the flat

outside rim and, farther in, wedge-shaped lecture rooms sloping toward the central core, all connected by corridor rings. A ramp will spiral around the cylindrical mechanical core. Architects: Holloway-Reeves and E. W. Waugh.

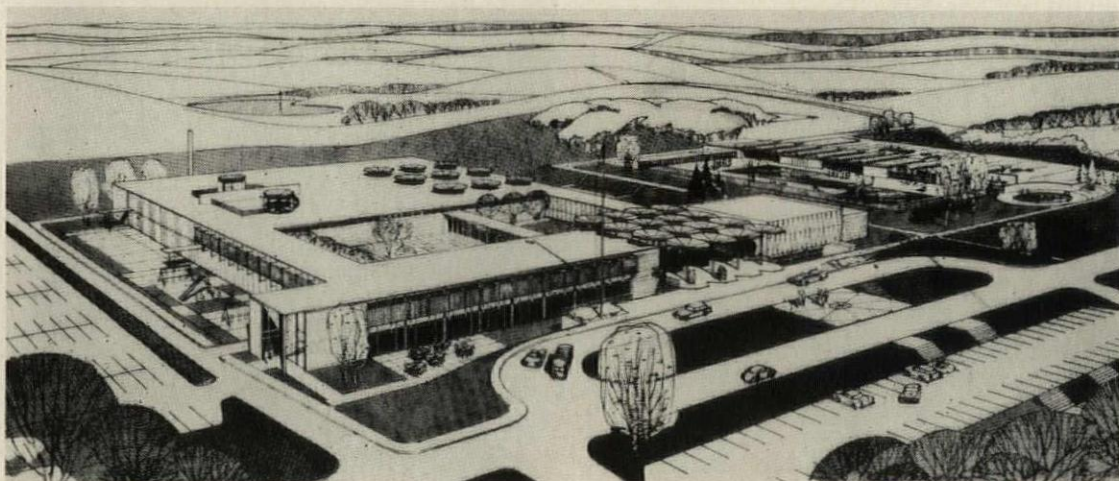

JEWISH COMMUNITY CENTER IN ST. LOUIS

This extensive recreation center for St. Louis' Jewish families, but open to everyone in the community, will be ready by 1963. Most of the outdoor facilities will be finished first, such as the swimming pool

and bathhouse (far right), archery range, picnic sites, and ball fields, spread over a 108-acre site. Last up, the main clubhouse will add a spacious auditorium wrapped in a diamond-patterned curtain

wall of blue and white, an indoor swimming pool, sun deck, offices, kitchens, and dressing rooms. The St. Louis firm of Russell, Mullgardt, Schwarz, Van Hoefen designed the center, to cost about \$2.8 million.

CHICAGO MOTEL TOWER

The first venture announced by Metropolitan Structures, Inc., successor to the late Herbert Greenwald's firm, is a 14-story "motor inn" near the Conrad Hilton in Chicago (below). The 285 rooms, the builders promise, will have views of Lake Michigan and Grant Park, not to mention the outdoor swimming pool topping a four-story extension next door. Architects: A. Epstein & Sons, Inc.

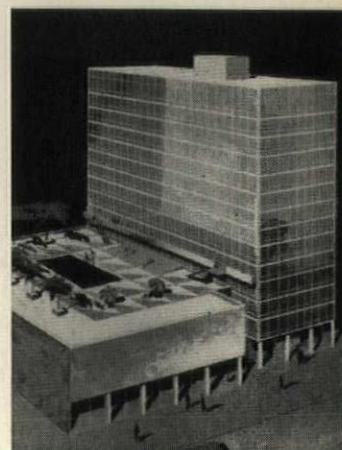

FOR THE NEW HARRIS TRUST BUILDING, CHICAGO, ILLINOIS

CURTAIN WALLS

IN STAINLESS STEEL
BY **GENERAL BRONZE**

Here's one of Chicago's newest and most modern office buildings—the new Harris Trust & Savings Bank Building. With fixed glass windows and stainless steel spandrel panels set within a gleaming stainless steel grid, the architects, Skidmore, Owings & Merrill, have created a building that is both pleasing and spectacular in its appearance.

An interesting effect has been provided by recessing the first, eleventh and twenty-second floors approximately 10 ft. on three sides. Air-conditioning and mechanical equipment is housed on the eleventh floor and is enclosed with stainless steel louvers. The twenty-second floor, used for executive offices, is glass enclosed and also features an interior open court.

As the country's foremost producer of curtain walls, windows and architectural metalwork in aluminum, bronze and stainless steel, General Bronze is also anxious to serve you. Why not call us in on your next job? Whether it be large or small, you'll find us helpful. Our catalogs are filed in Sweet's.



Harris Trust & Savings Bank, Chicago, Ill.
Architects: Skidmore, Owings & Merrill
Contractors: Turner Construction Co.

GENERAL BRONZE
CORPORATION · GARDEN CITY, N.Y.
SALES OFFICE: 100 PARK AVE., NEW YORK 17, N. Y.



PERMATITE DIVISION—Windows, Curtain Walls, Architectural Metal Work.
ALWINTITE DIVISION—Stock-size Aluminum Windows and Doors.
BRACH MFG. CO. DIVISION—Radio, Television and Electronic Equipment.
STEEL WELDMENTS, INC. DIVISION—Custom fabrication in Steel and Iron.

Functional luminous ceiling . . . adjustable walls . . . tiles: deep-scored, mesh-backed, rubber-matted.

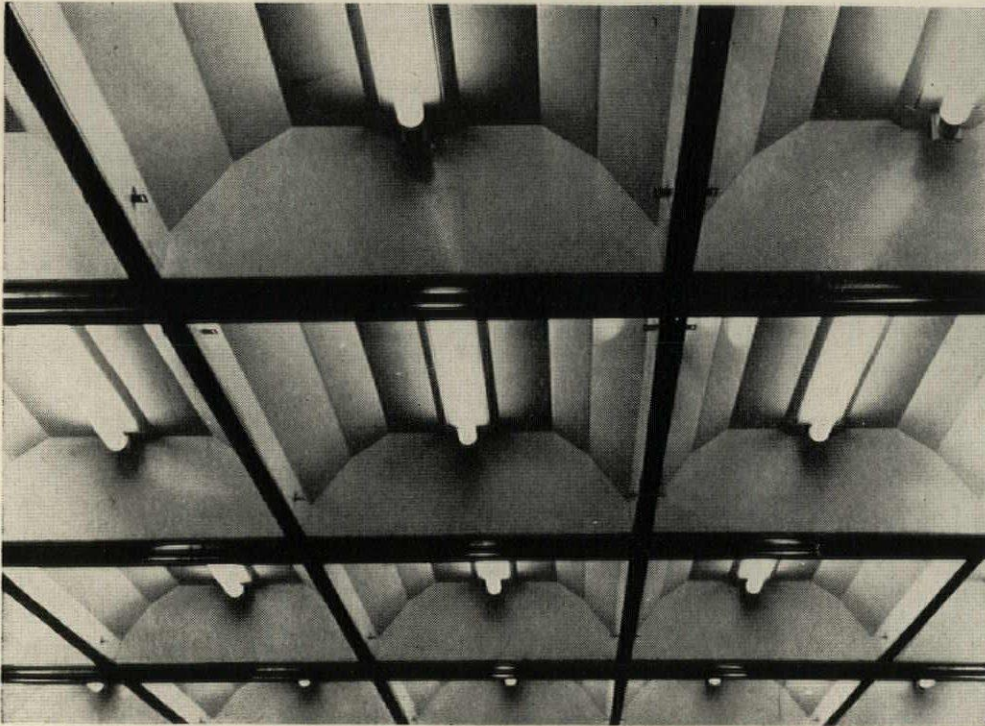

FOUR-FUNCTION CEILING

The latest addition to Park Avenue's row of sleek corporation headquarters is the giant of them all, the 52-story Union Carbide Corp. home office. As befits a corporation which makes, among other things, steel alloys and plastics, the building itself will be a showcase for its products. A case in point is Union Carbide's ceiling system, composed largely of Bakelite rigid vinyl crisscrossed by stainless-steel runners.

This ceiling works hard. Besides supplying light, it distributes air, blocks sound, and anchors movable partitions. It grew out of several preliminary versions put up and tested in Union Carbide's mock-up building in Eastfield, N. Y. Working with Union Carbide's engineering staff, Skidmore, Owings & Merrill, the building's architects, Syska & Hennessy, and Bolt, Beranek & Newman all had a hand in the ceiling's development. The final system, partly installed in the new building (where eventually there will be 800,000 square feet of it), is tailored to the building's 5-foot-square module in panels 5 by 2½ feet.

Viewed from below, the finished ceiling seems an almost unbroken plane of light, for its brightness is evenly distributed and the runners between panels are unobtrusive. Inside each panel there is one rapid-start 40-watt fluorescent tube which produces at least 50 foot-candles of light at desk level, or 4 watts per square foot, a one-third saving over the 6 watts previously thought necessary to maintain this level of illumination.

Above the diffuser, which is laminated vinyl sheet framed in aluminum and tightly gasketed, is a one-piece white enameled steel reflector with built-in angles to spread light out to the panel edge. The grid pattern is formed by A and T runners of cold-roll-formed stainless steel. Ducts and connecting boots serve the major A runners, which are pierced and curved to distribute conditioned air and exhaust "used" air. This air-conditioning system operates over the whole ceiling to within 15 feet of the outside wall, where

continued on page 72

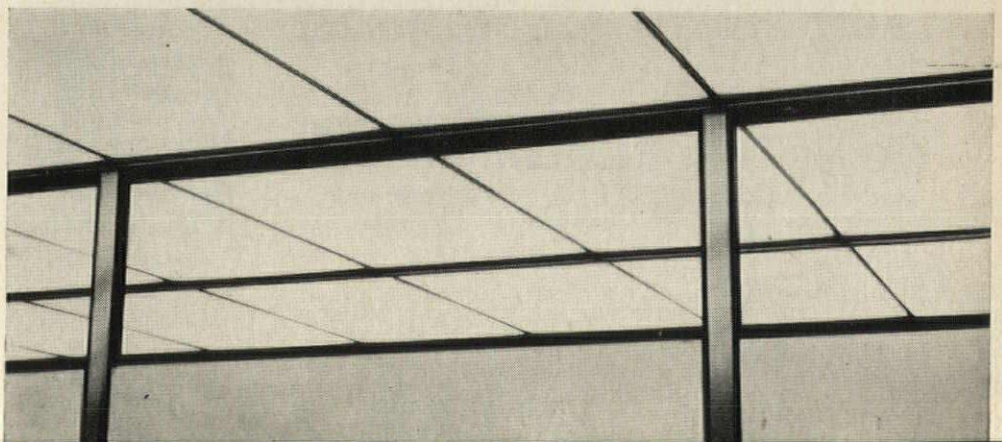
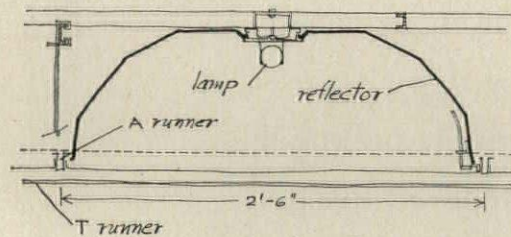
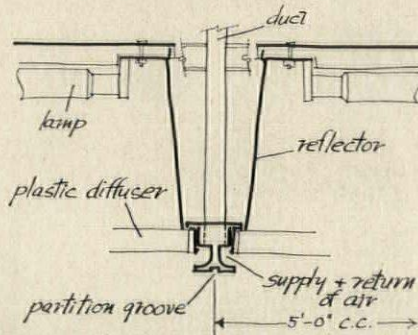



it's not the original cost-it's the upkeep

the application of *MicroRold*[®] Stainless Steel to your building will assure you lowest maintenance costs...the fact that stainless steel's beauty is permanent . . . and so easy to maintain—makes it the most practical choice in contemporary design.

Send for your free copy, Bulletin 259—"ARCHITECTURAL STAINLESS ENGINEERING DATA," and Bulletin 459—"COLORROLD STAINLESS STEEL COLOR CARD."

WASHINGTON STEEL CORPORATION
4-K WOODLAND AVENUE WASHINGTON, PA.



a separate perimeter system takes over.

Both A and T runners are grooved for partitions, making it easy to rearrange office space overnight. Corridor widths may be any multiple of 2½ feet, and offices may be any modular size providing one dimension is at least 10 feet.

Sound transmission is kept to a comfortable level by tight gasketing at all joints and is further helped by the one-piece light reflector, which forms a completely sealed modular unit.

With all its functions, this ceiling costs about \$6 per square foot. Union Carbide expects to save a considerable amount annually from lowered maintenance and power consumption.

Manufacturer: Frink Corp., 211 63rd St., Brooklyn, N. Y.

SCULPTURED TILE

Peter Ostuni, a New York City artist, has designed a new series of tiles, two of them shown here. Hand-made of pumice stone, marble powder, and asbestos, the tiles are light in weight (2½ pounds per square foot) and are said to be fire- and waterproof. The line consists of ten designs and eight colors: white, sand, dark brown, black, gray, beige, ochre, and moss green. On exterior walls, the tiles are set in cement; indoors, in tile-setting adhesive.

The eight deep designs cost \$8 each, and are available in only one size, a 12-inch

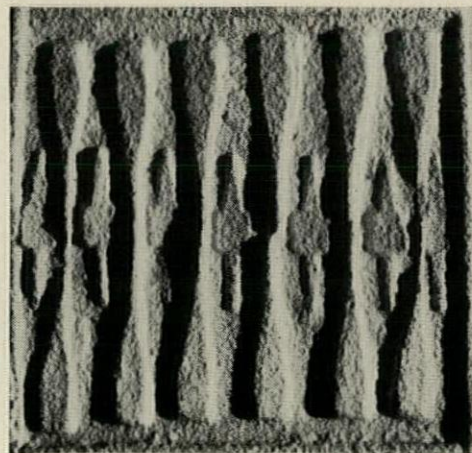

square. Two complementary shallow tiles are less expensive: \$6 for a 12-inch square, and \$2 for a 6-inch square. Custom designs by Ostuni are also available, but at additional cost. The tiles are made by Albra Cold Process Ceramics.

Distributor: Virginia Frankel, 235 East 58th St., New York 22.

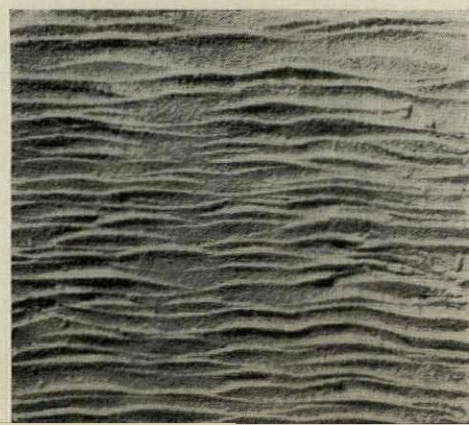

RUBBER-CUSHIONED TILE

Set in a rubber mat, small ceramic tiles "give" slightly underfoot, making them comfortable to stand or walk on. Besides lending resiliency, the rubber grid softens foot noises and insulates against cold, heat, and electric shock. The little tiles in *Ceramaflex* resist scratches and dents, and they project just far enough above the grid to make the floor slip-resistant.

Marketed in cartons of 36 nine-inch squares, each of these squares contains 64 one-inch tiles and is 7/32 inch thick. Solid colors are not offered, but there are

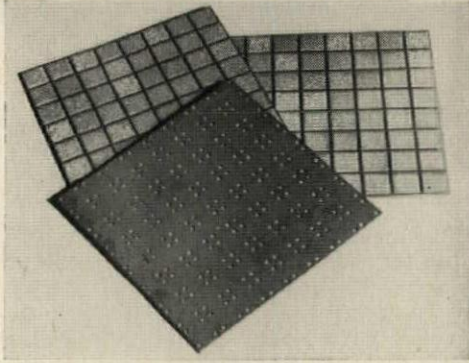

12 color mixtures, each keyed to a basic color. *Ceramaflex* may be installed with adhesive over wood or concrete subfloors, but it is not recommended for use on wood subfloors over basement concrete slabs. The manufacturer quotes savings of 20 per cent over the installation cost of conventional ceramic mosaic.

Manufacturer: U. S. Ceramic Tile Co., 217 4th St., N.E., Canton 2, Ohio.

MESH-MOUNTED TILE

Most ceramic tile of small dimension is delivered in rectangles 1 foot by 2 feet with paper pasted temporarily to its face. *Perma-Bak* has a stiff mesh on its back side which simplifies handling and saves up to 50 per cent in labor costs on large jobs. This saving results from the tile's being fully visible during application, which makes alignment easier, and there is nothing to remove once the tile is in place.

The mesh backing is a twisted kraft paper woven and impregnated with poly-
continued on page 74

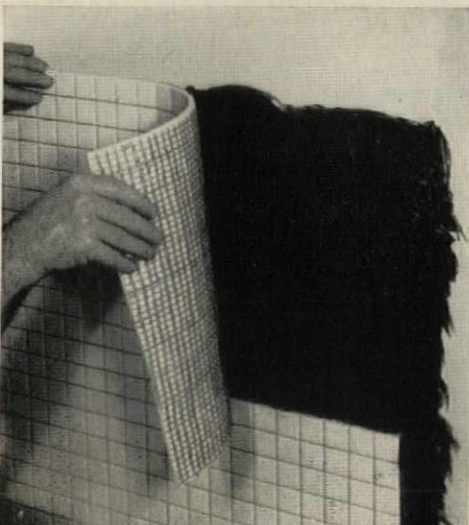

Your client's
building
isn't complete
without

FULL TIME FIRE PROTECTION

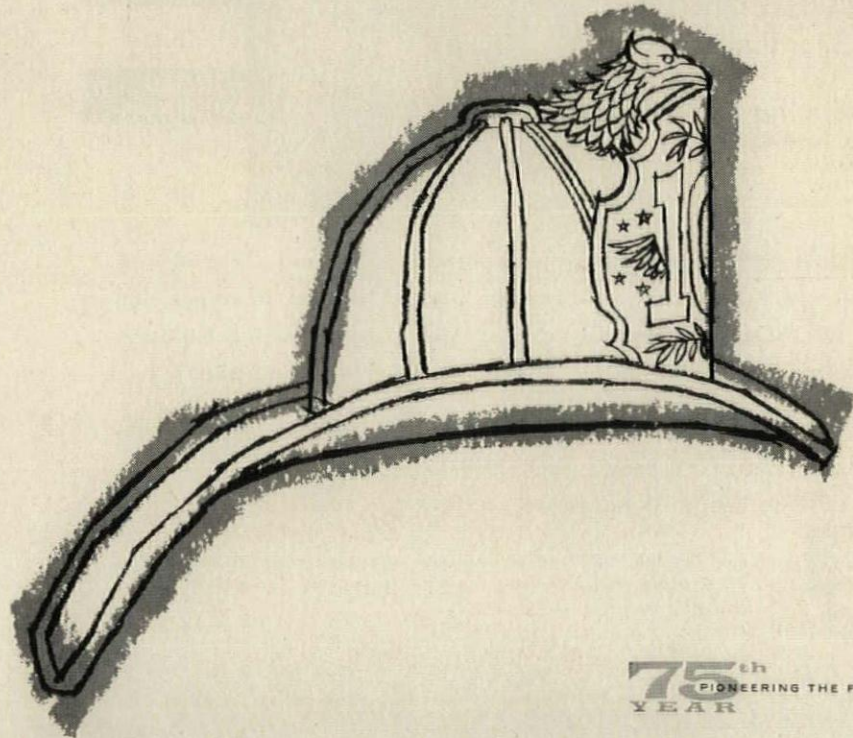

75th
PIONEERING THE FUTURE
YEAR

FIRES don't care *when* they happen! That's why it's important to specify *automatic* day and night fire protection with a Honeywell fire alarm system. Honeywell alarms can protect your client's building two important ways. 1. By automatically signalling the location of the fire instantly—*not* depending on someone to discover and report it. 2. By relaying the alarm to the local fire station automatically, thus saving precious minutes. This automatic fire protection is vital, not only in hospitals and schools, but in every type of building. For more information about Honeywell fire alarm systems, consult your electrical engineer or contractor; or write Minneapolis-Honeywell, Minneapolis 8, Minnesota.

Honeywell



First in Control

SINCE 1885

First Low Cost Decorative Door



Beautiful
ALUMINUM
and
VINYL-ON-STEEL
FLUSH DOORS

RICH VINYL COLORS
VARIETY OF SIZES & TYPES

Suitable for Exterior
or Interior Use



DécorDors brings high quality decorative doors into the realm of general specifications . . . through standardization of types and sizes. DécorDors successfully passed the rugged Forest Products Laboratory Test assimilating severest weathering conditions.

DécorDors withstand heavy traffic-use, with exceptional strength-to-weight ratio . . . passed the 1,000,000 cycle slam test without failure. Wide range of hardware applications available.



Color Catalog, DHSV-60 is available through your nearest D&H Distributor, listed in the Yellow Pages, in Sweet's Architectural File or by writing direct.

D-H "The Complete Door Line"

MINERAL CORE

PyroDor®

FIRE DOORS

with UL Labels at
no extra cost!

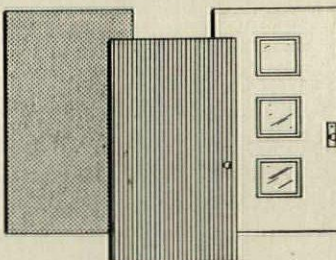

ECONOMICAL



ALUMINUM • WOOD
• VINYL-ON-STEEL
DECORATIVE DOORS

NEW! PyroDor Sliding Fire Door With Pyromatic Door Release

WRITE For New Dusing & Hunt Color Catalogs or Call your nearby D & H Distributor —
Consult the Yellow Pages or Sweet's Architectural File, or Write direct.

DUSING & HUNT, Inc.

Over 50 Years Manufacturing Fireproof Doors and Metal Trim

69 LAKE STREET

LE ROY, NEW YORK

vinyl plastic for water resistance. It is bonded tightly to the tile back with thermal-set adhesive. Conventional or thin-set mortar or mastic may be used for setting; these form a strong bond, for they seep around the mesh.

Ceramic Perma-Bak-mounted tiles are available in most standard patterns at a cost about 10 per cent higher than conventional tile.

Manufacturer: American-Olean Tile Co., Olean, N. Y.

EMERGENCY EXIT

Designed for use in first-floor classrooms and single-story buildings of other kinds, this aluminum window swings out a full 180 degrees should it be needed as an emergency exit. The *Lupton Emergency Exit Window* looks like any standard projected window except that it has a slightly heavier frame. Light pressure on

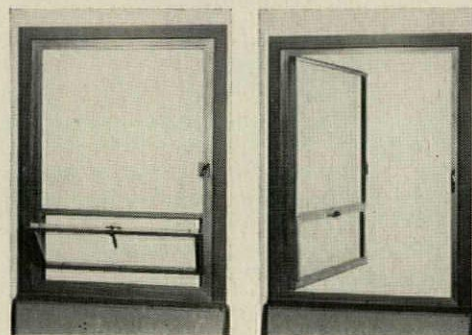

the locking handle releases the whole window.

Though the window shown has a projected ventilator, the same safety feature is offered in windows without ventilators and those with horizontal muntins. Right or left openings may be ordered, and sizes available range from 2 feet 11 inches up to 3 feet 4 inches wide and 4 feet 1 inch to 5 feet 1 inch high. This window costs about 25 per cent more than a standard projected ventilator window but, since one or two per room would probably be enough, the added cost per room would be nominal.

Manufacturer: Michael Flynn Manufacturing Co., 700 East Godfrey Ave., Philadelphia 24.

ADJUSTABLE CLASSROOM WALLS

Chalkboards that move up and down the wall, adjusting to a child's height, are one component of *Moduwall*, the name Brunswick-Balke-Collender has given its new wall-hung schoolroom equipment. All of *Moduwall's* components—pegboard, tackboard, flannel board, bookshelves, maga-

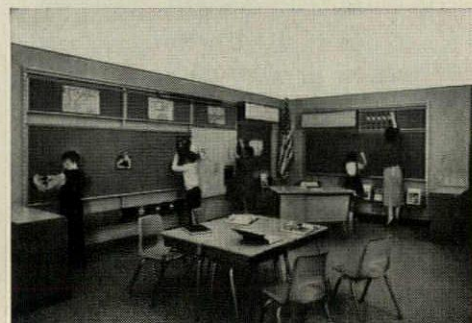

zine racks, easels, and utility rails for maps and movie screens, in addition to the chalkboard—work on a 4-foot module and are interchangeable. In fact, the only fixed parts of the system are parallel strips fastened to the wall. Hooks at the top of each component lock into slots punched in the strips; clips on the bottom edge snap snugly between them. To switch units, the teacher (or perhaps a good-sized pupil) unhooks and pulls out the unit, then substitutes another.

Moduwall aims at flexibility in classrooms. By simply raising the eye level and replacing pegboard with chalkboard, a first-grade classroom could be converted to, say, a junior high school room.

A sample 16-foot wall like the one on the facing page, in Brunswick's model classroom in Kalamazoo, would cost from \$150 to \$200. The Moduwall chalkboard is comparable in cost to a built-in steel chalkboard.

Manufacturer: Brunswick-Balke-Collender Co., 623 South Wabash Ave., Chicago 5.

PLASTIC SHELTER

The canopies billowing over the service station below are thin reinforced plastic sheets supported by hollow plastic beams. Shipped and sold as a package, the beams arrive in three sections, and the sheets in rolls 2 by 42 feet. Once the components are on the site, workmen assemble the beams and bolt them to steel girder footings. Next, they rivet the plastic strips over the curved ribs. From unwrapping to completion, the operation can be completed by three unskilled workers in less than five days.



Developed jointly by Monsanto Chemical Co. and the Tru-Scale Division of Wasco Chemical Co., the canopy is intended as an inexpensive shelter for public parks, parking areas, drive-ins, or service stations. Each canopy is 30 by 30 feet, stands 20 feet high (without the base platform shown in photo), and can be ordered in almost any color. If a longer shelter is desired, the basic unit may be lengthened by adding more beams and skin. The manufacturer says that it stood up well to 80-mile-an-hour wind tests and that it requires virtually no maintenance. Cost: from \$5,000 to \$6,000 for each canopy, plus another \$1,000 for erection.

Manufacturer: Tru-Scale Div., Wasco Chemical Co., 2501 South West St., Wichita, Kan. END

McKINNEY HINGES MAKE NEWS!

SELECTED FOR NEW WASHINGTON STAR NEWSPAPER BUILDING

The new Washington (D.C.) Star Building houses the latest newspaper publishing facilities. In addition to high-speed presses and other modern printing equipment, quality building materials are used throughout to assure maximum operating efficiency.

McKinney Ball Bearing Hinges were selected for installation on all heavy duty interior and exterior doors. It's through dependable operation on important jobs such as this that McKinney has built a

reputation for fine quality and trouble-free service.

On your next important job, give your clients the best. Specify McKinney Hinges.

Architects: Faulkner, Kingsbury, and Stenhouse, Washington, D.C.

General Contractors: Charles H. Tompkins Co., Washington, D.C.

Hardware Consultants: Barber & Ross Company, Washington, D.C.

Hinges: 530 pairs McKinney Ball Bearing Hinges for all heavy duty interior and exterior doors.

McKINNEY

PITTSBURGH 33, PENNSYLVANIA · IN CANADA: McKINNEY-SKILLCRAFT LTD., TORONTO, ONTARIO

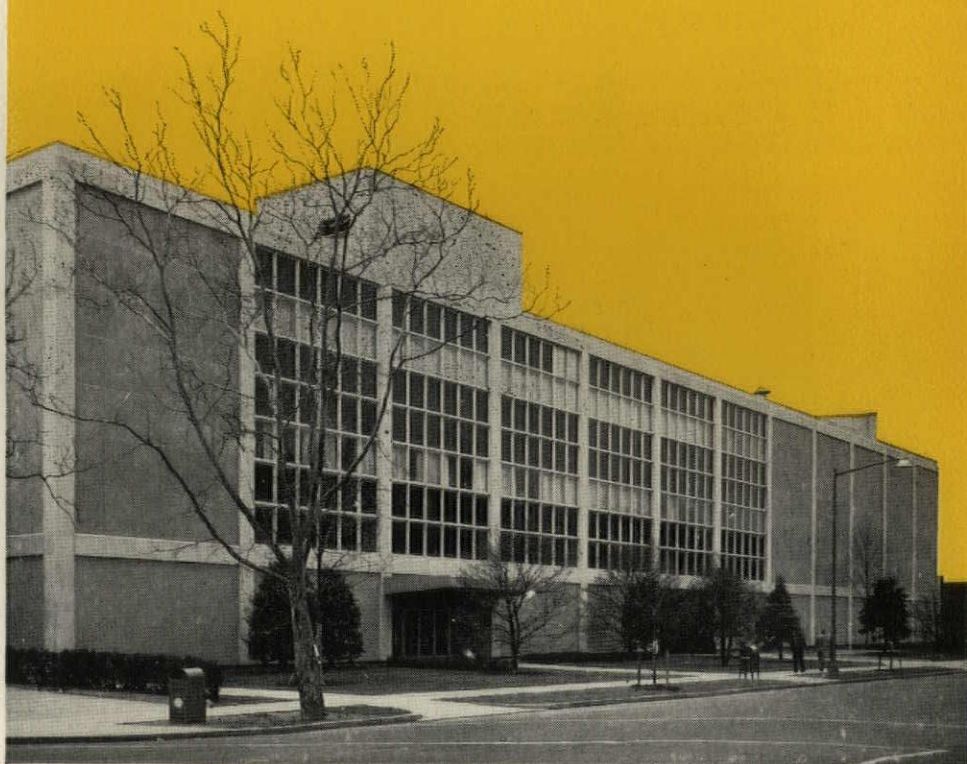

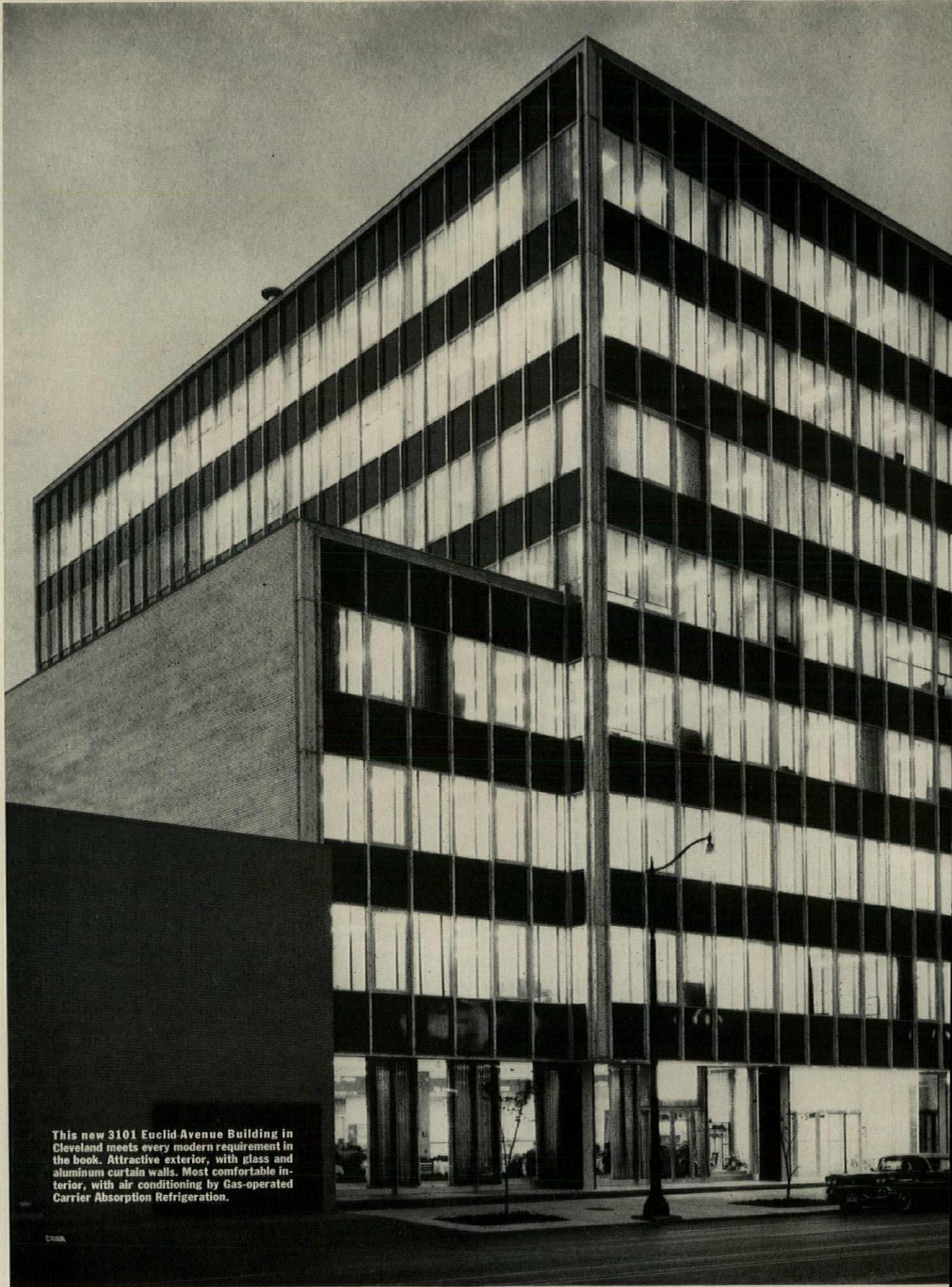

This new 3101 Euclid Avenue Building in Cleveland meets every modern requirement in the book. Attractive exterior, with glass and aluminum curtain walls. Most comfortable interior, with air conditioning by Gas-operated Carrier Absorption Refrigeration.

Attracts tenants with comfort cooling by GAS-operated CARRIER Absorption Refrigeration

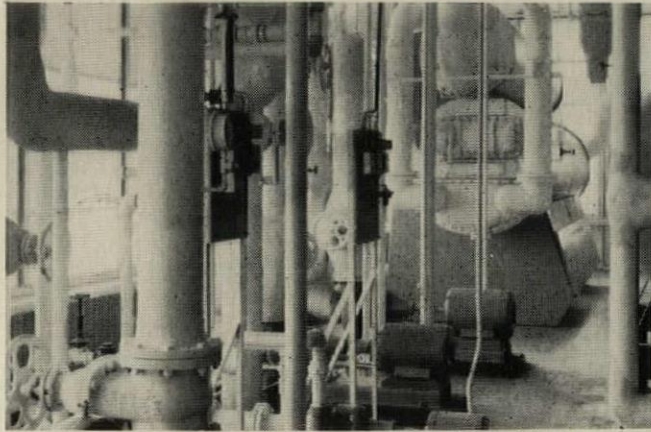

AIR CONDITIONING PENTHOUSE. This equipment in penthouse atop the building includes two gas-fired Bryant boilers, 300-ton capacity Carrier Absorption unit to chill water for the Carrier Weathermaster air conditioning system, and Carrier cooling towers, too. Roof-top installation frees basement area for other uses.

H. L. Vokes Company of Cleveland, designers and builders of the new 3101 Euclid Avenue Building in that city, are experts in two-way satisfaction. They satisfied their tenants and their own cost requirements with one of the most efficient types of modern air conditioning—Gas-operated Carrier Absorption Refrigeration.

Comfort cooling in this building starts at the same two gas-fired boilers that furnish heat in winter. The Carrier absorption unit uses low pressure steam from the boilers as the energy source for water chilling. Thus, no prime mover is needed. Boiler capacity is put to use on a year 'round basis. And thrifty gas keeps fuel costs low.

Judge for yourself the efficiency and economy of Gas-operated Carrier Absorption Refrigeration. Specific performance data and cost details are yours for the asking. Just call your local gas company, or write to Carrier Corporation, Syracuse 1, New York. **AMERICAN GAS ASSOCIATION.**

FOR HEATING & COOLING  **GAS IS GOOD BUSINESS**

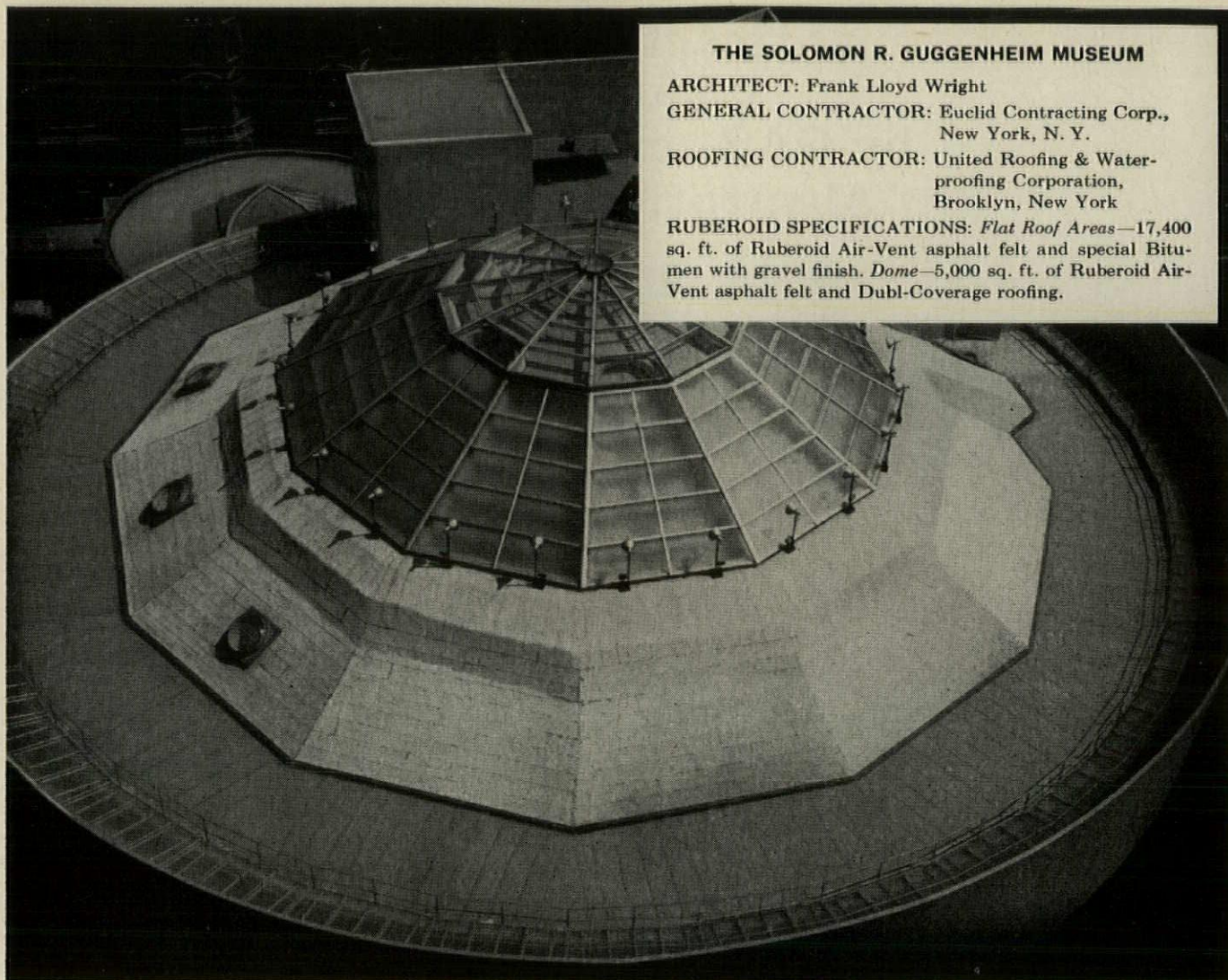

THE SOLOMON R. GUGGENHEIM MUSEUM

ARCHITECT: Frank Lloyd Wright

GENERAL CONTRACTOR: Euclid Contracting Corp.,
New York, N. Y.

ROOFING CONTRACTOR: United Roofing & Water-
proofing Corporation,
Brooklyn, New York

RUBEROID SPECIFICATIONS: *Flat Roof Areas*—17,400
sq. ft. of Ruberoid Air-Vent asphalt felt and special Bitu-
men with gravel finish. *Dome*—5,000 sq. ft. of Ruberoid Air-
Vent asphalt felt and Dobl-Coverage roofing.

What's on top really counts when it's RUBEROID SPECIAL ROOFING BITUMEN



William Rockhill Nelson Gallery of Art, Kansas City, Mo. For 27 years—since 1933—a Ruberoid Special Roofing Bitumen roof has provided protection for this Kansas City landmark. Another example of the economy and durability of Ruberoid Roofing.

Special Roofing Bitumen provides rigidly controlled quality for any built-up roof. This alone adds many extra years of weather-tight, maintenance-free service for any type of building.

Add to this quality an engineered application by a Ruberoid Approved Roofer and you'll be assured of a built-up roofing combination that can't be topped in the industry today.

Specify Ruberoid Special Roofing Bitumen on your next project for assured all-weather performance and extra economy.

For detailed Ruberoid Specification Data, write: The RUBEROID Co., 500 Fifth Avenue, New York 36, New York.

The RUBEROID Co.



Naugatuck MARVIBOND

VINYL-TO-METAL LAMINATING PROCESS

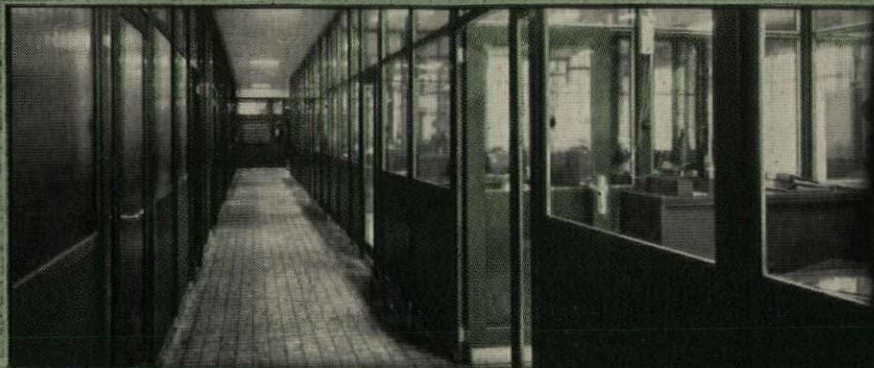

Toughest, most beautiful protection in the world!

It's MARVIBOND®—the patented process that permanently bonds a blanket of tough vinyl plastic to sheets of steel, aluminum, or other metals to provide lasting beauty that's unique.

Because MARVIBOND panels are *prefinished*, they actually cost less to use than bare metals that must be painted on the site.

Because the tough vinyl surface is practically impossible to harm, these MARVIBOND panels can be considered *permanently finished*. The only maintenance they'll ever need is an occasional wash down.

And the range of decorative possibilities is as broad as that of vinyl itself...extending from smooth, marbelized patterns through intricate upholstery weaves. What's more, the tough vinyl surface has a valuable sound and thermal insulating effect. And it never feels cold or unpleasant to the touch.

If you don't yet know all about MARVIBOND, and the practical possibilities it offers, contact your nearest distributor or the address below. You may well want to put MARVIBOND to work on the very job you're planning now.



United States Rubber

Naugatuck Chemical Division

DEPT. 431-D ELM STREET
NAUGATUCK, CONNECTICUT

KRALASTIC RUBBER-RESINS • MARVINOL VINYLs • VIBRIN POLYESTERS

Akron • Boston • Chicago • Gastonia • Los Angeles • Memphis • New York • Phila. • CANADA: Naugatuck Chemicals • Elmira, Ont. • Cable: Rubexport, N.Y.

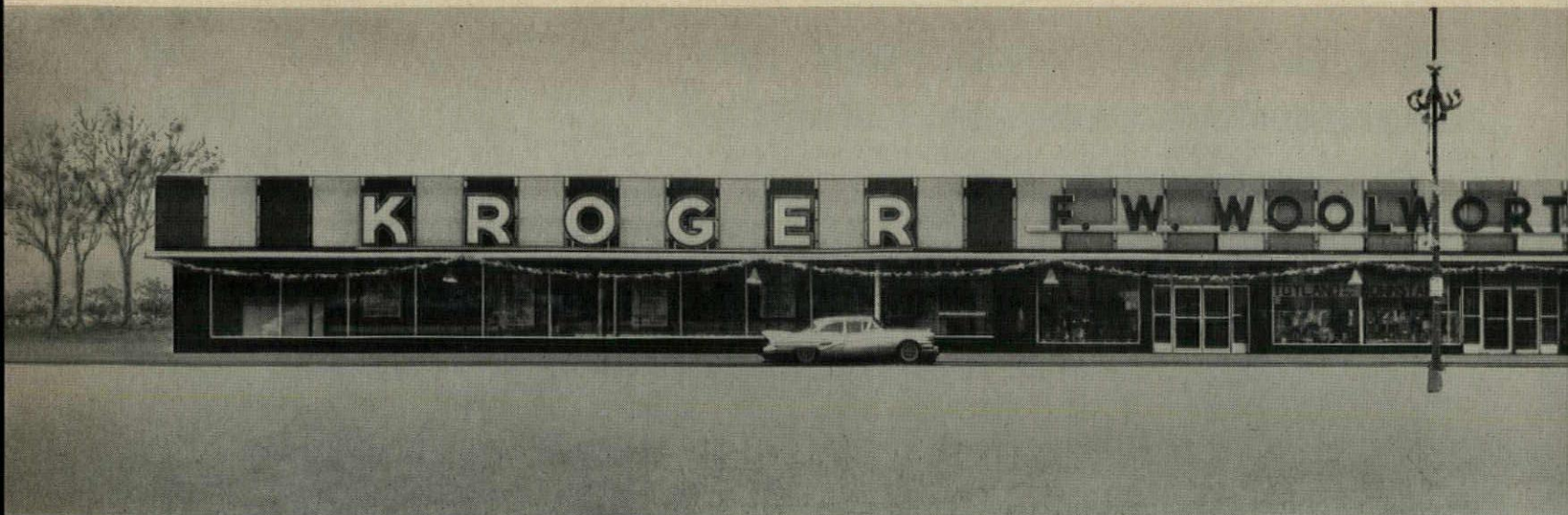

From an old farm to a \$20 million shopping area—that's the exciting story



This is the fifth and largest unit. It contains 16 stores and 225,000 sq. ft.



Owners: At left, Mr. A. Page Sloss. Center, Mr. Everett Shepherd. At right, builder, Mr. H. A. Brice, Sr.
Architect: Henry Sprott Long, Birmingham, Alabama.
Steel Erector: Brady Faucett Erection Co., Birmingham, Alabama.



of Five Points West Shopping City, Birmingham, Alabama.



of space. Everett Shepherd and Page Sloss conceived the idea and developed it into the biggest shopping center in Alabama. Builder, H. A. Brice, Sr., gave it a backbone of USS Structural Steel —417 tons of it. “A builder can make longer spans, and do the job quicker with structural steel,” says Mr. Brice, “and most important, it’s economical and we can get it right here in Birmingham from United States Steel.”

USS is a registered trademark



United States Steel Corporation—Pittsburgh
Columbia-Geneva Steel—San Francisco
Tennessee Coal & Iron—Fairfield, Alabama
United States Steel Supply—Steel Service Centers
United States Steel Export Company

United States Steel

In the world's most beautiful buildings

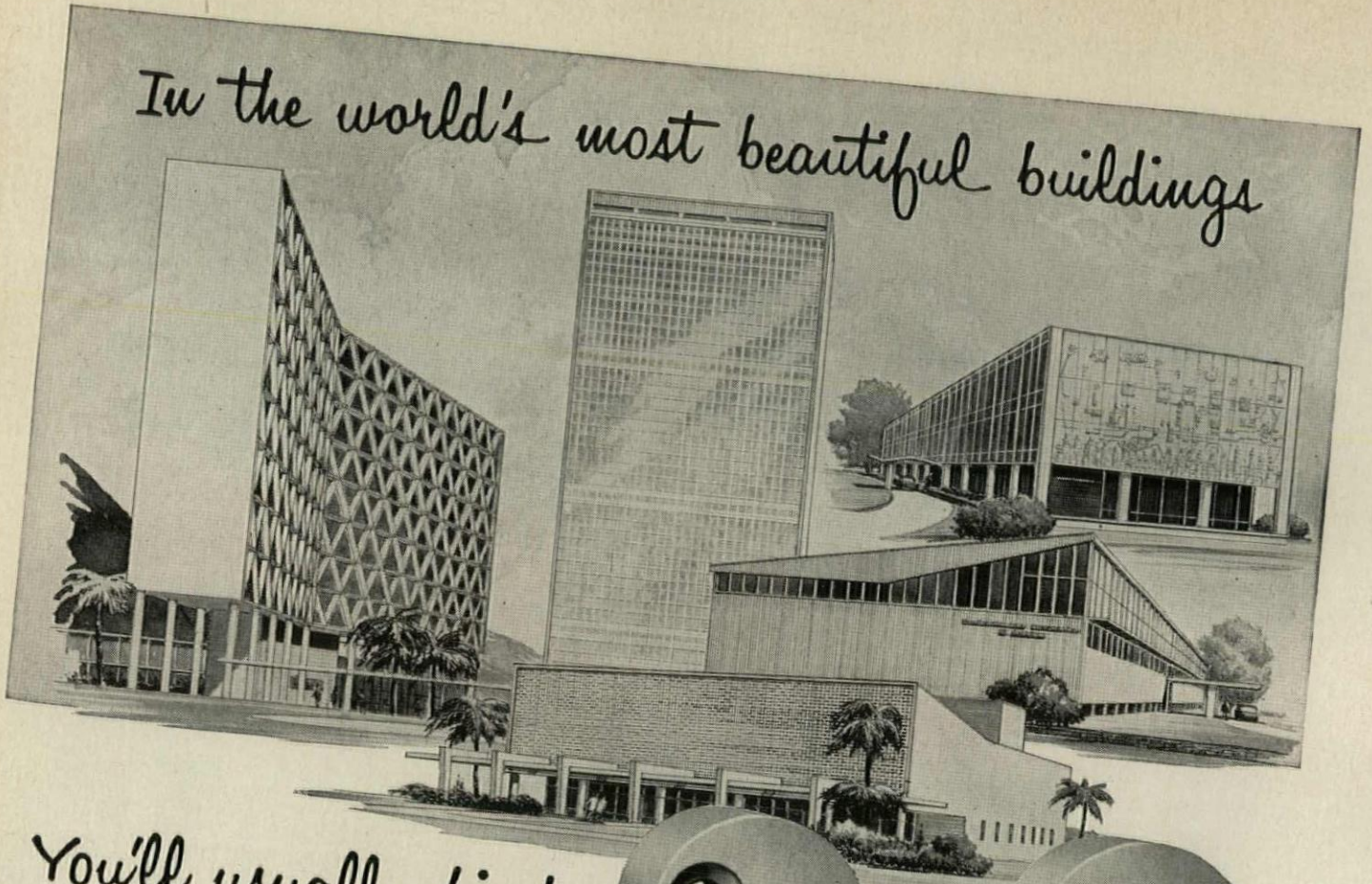

You'll usually find

SOSS
INVISIBLE
HINGES

**"The Hinge
That Hides Itself"**

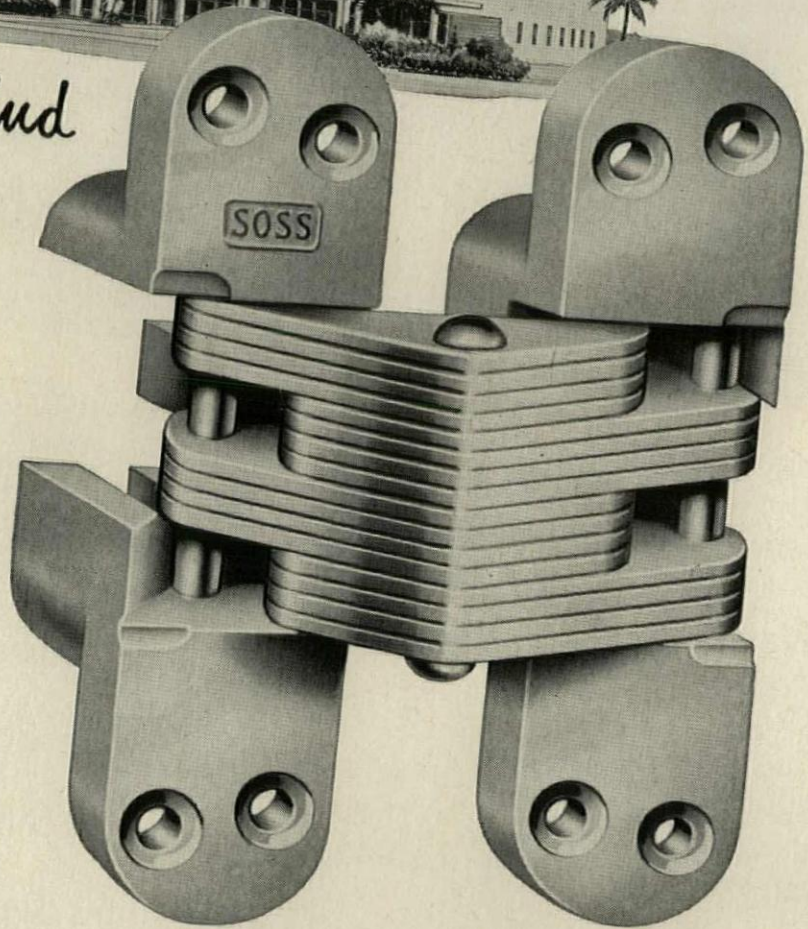

for complete information and prices, see your building supply dealer or hardware dealer, or write us.

SOSS MANUFACTURING COMPANY

Dept. AF-8 P. O. BOX 38, DETROIT 13, MICHIGAN



This Pace Setter Home for 1960 was designed and decorated by the editors of House Beautiful as "A dwelling place that is a complete work of art . . . to symbolize those hopes, aspirations, and human emotions that are summed up in the single word; home." They point out, "A stone tower, topped with a clear plastic 'Skydome', instead of a roof, is the moodsetter for this house . . . This is something new in shelter. And until the clear plastic Skydome came into being as a commercial reality, such a space would not have been feasible. Here is real exploitation of a 20th-century tool!"



PACE SETTER FOR 1960 ... DAYLIGHTING BY WASCO

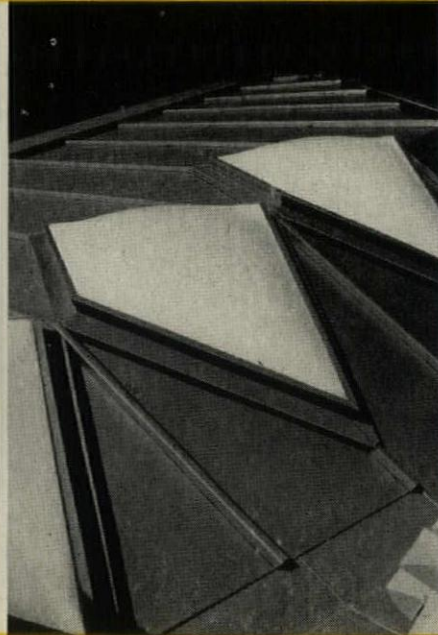
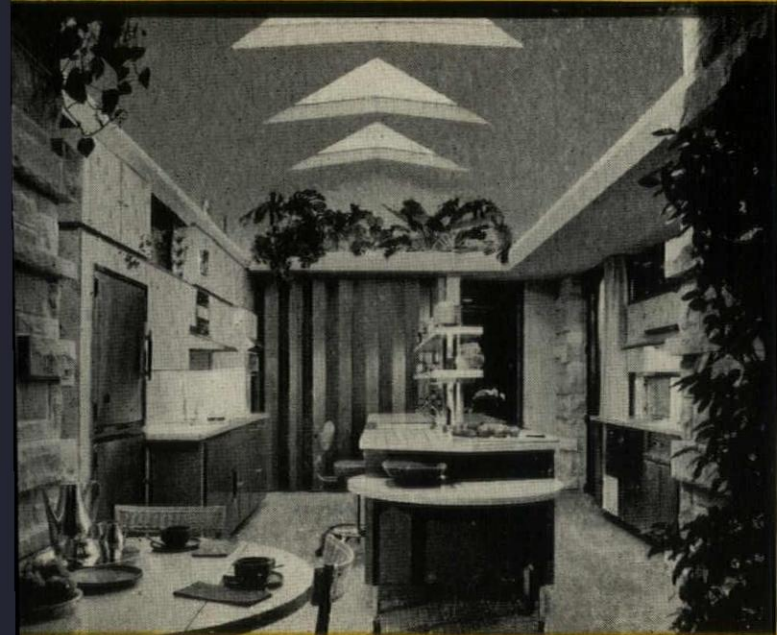

Wasco Skydomes — in both standard and special shapes — figure repeatedly in the Pace Setter's most striking effects. The "light tower" entrance hall uses a standard 20" x 52" Skydome. The kitchen (at left), the indoor swimming pool, bathrooms, and corridors use a variety of custom formats. This achievement shows how Wasco designs Daylighting products to fit the ever-changing needs of creative architecture. Skydomes are truly a "20th Century Tool", available in a variety of types and sizes. See Sweet's File 20 a/Wa.

GOOD DAYLIGHTING DESIGN STARTS WITH

WASCO PRODUCTS, 5 BAY STATE RD., CAMBRIDGE 38, MASS.
IN CANADA: WASCO PRODUCTS (CANADA) LTD., TORONTO, ONT.



WASCO
SKYDOMES



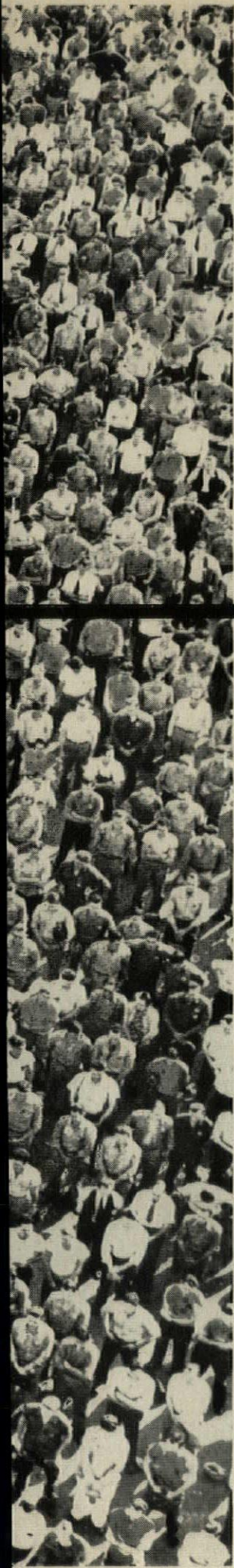

6000 Lennox Specialists

*give you the help
you want, when
you want it*

*World leader in indoor comfort for homes,
business, schools and industry*

LENNOX
HEATING AND AIR CONDITIONING

The broad base of Lennox superior service to Architects is its "army" of 6000 specialists—5500 of which are dealers known as *Comfort Craftsmen*. Each works directly with his nearest of 10 strategically located factories to assure on-schedule delivery and installation of the world's finest heating/air-conditioning equipment.

Lennox *Comfort Craftsmen* are factory-trained and are pledged to ensure customer satisfaction. They even check back after occupancy to make sure the system is operating to perfection.

Spearheading this unique "army" is the industry's most experienced field force—250 factory-trained territorial managers, 30 experienced service engineers, 50 seasoned graduate technicians. This technically trained and practically experienced help is at the disposal of your architect-engineer team in selecting the perfect combination of equipment for any structure . . . giving you a new design freedom.

Your local Lennox *Comfort Craftsman* is listed in your Yellow Pages. Call him—or write *Lennox Industries Inc.*, 322 S. 12th Ave., Marshalltown, Iowa.

© 1960 Lennox Industries Inc., founded 1895; Marshalltown and Des Moines, Ia.; Syracuse, N.Y.; Columbus, O.; Decatur, Ga.; Ft. Worth; Los Angeles; Salt Lake City.
In Canada: Toronto, Montreal, Calgary, Vancouver, Winnipeg.

LENNOX 65 YEARS
OF PROGRESSIVE ENGINEERING

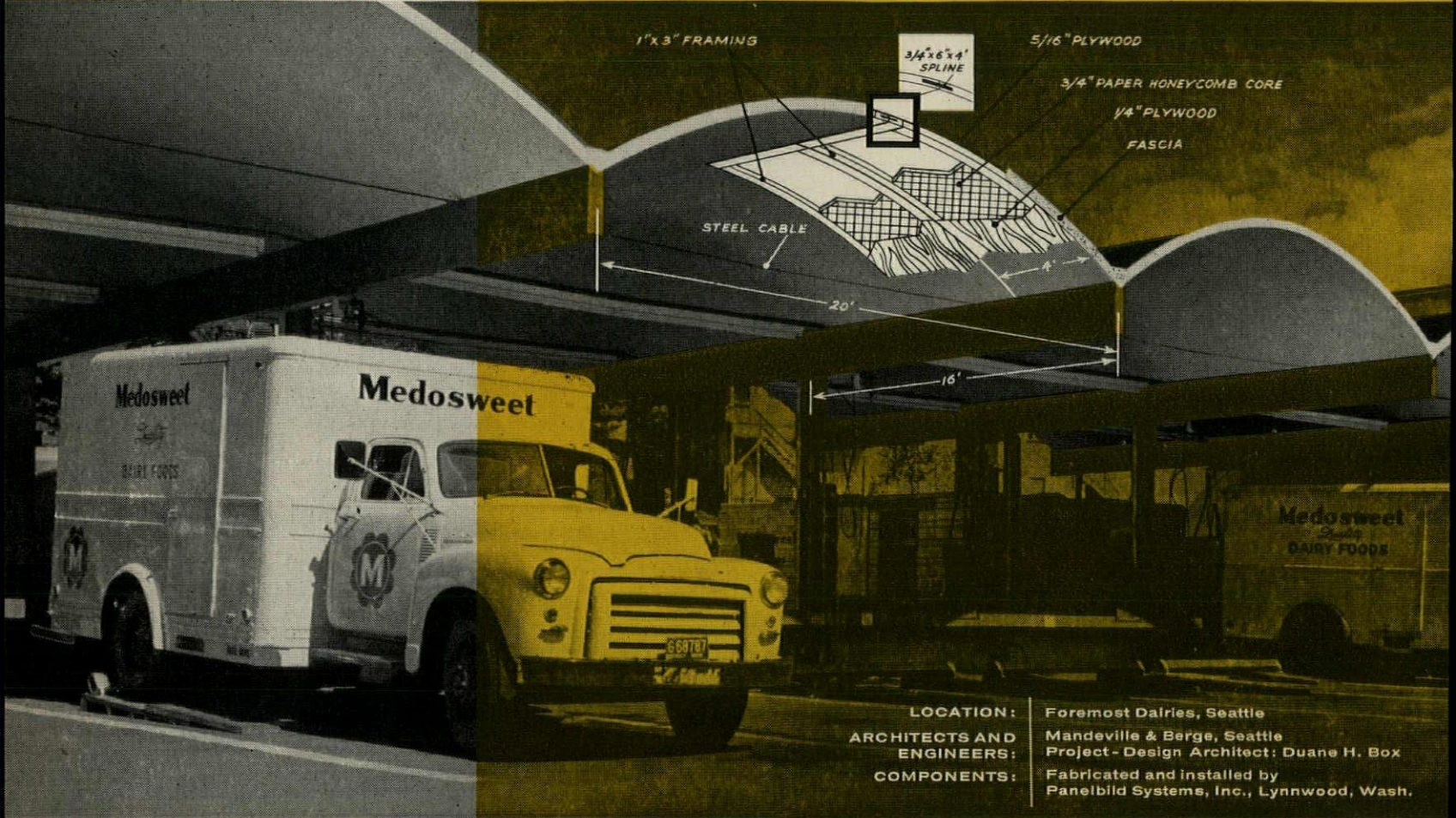
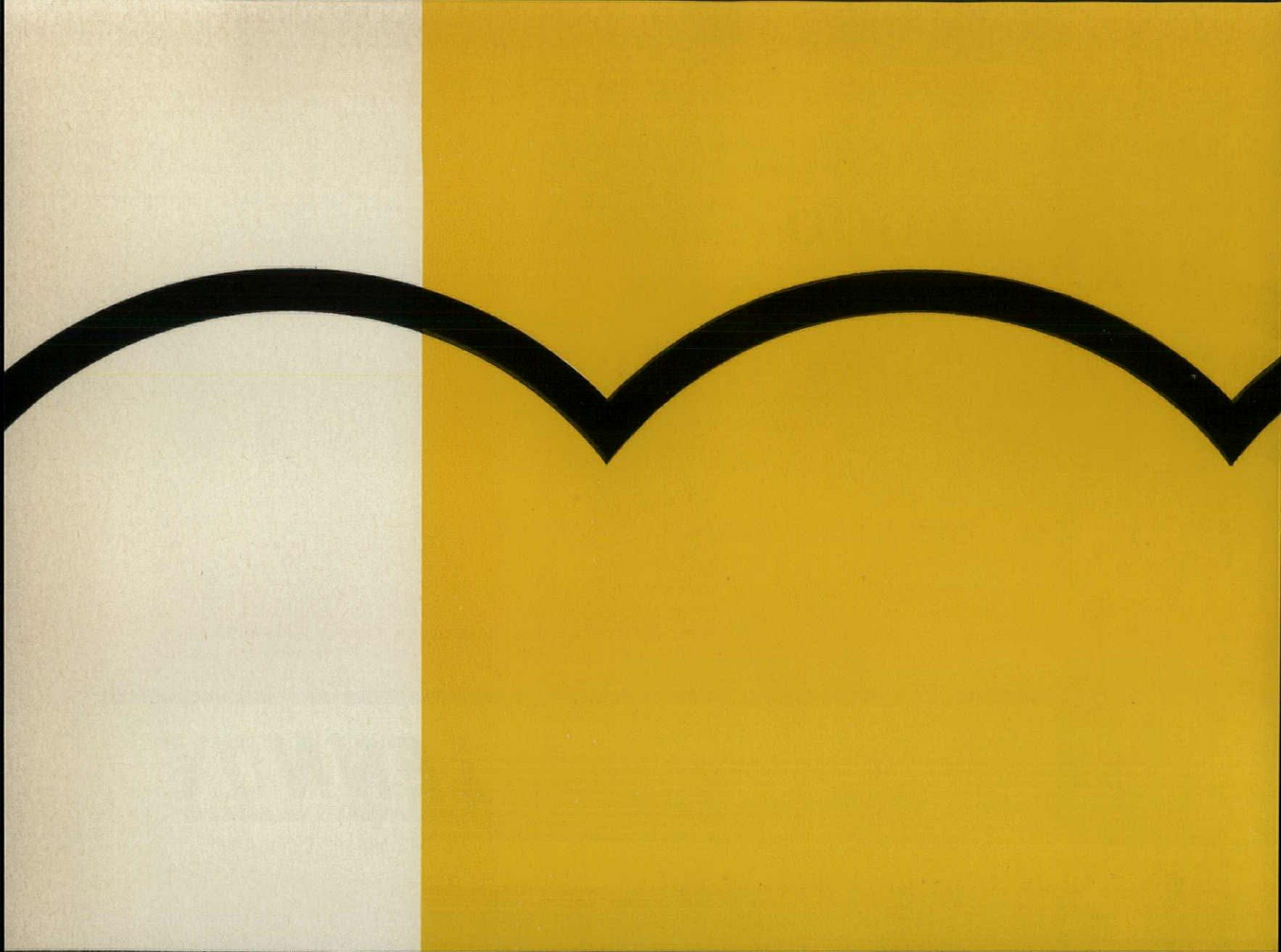

1"x3" FRAMING

3/4"x6"x4" SPLINE

5/16" PLYWOOD

3/4" PAPER HONEYCOMB CORE

1/4" PLYWOOD

FASCIA

STEEL CABLE

20'

4'

16'

Medosweet

Medosweet

DAIRY FOODS

Medosweet
DAIRY FOODS

LOCATION: Foremost Dairies, Seattle
ARCHITECTS AND ENGINEERS: Mandeville & Berge, Seattle
PROJECT-DESIGN ARCHITECT: Duane H. Box
COMPONENTS: Fabricated and installed by Panelbild Systems, Inc., Lynnwood, Wash.



new approaches to structural design with fir plywood



THE GRACEFUL, repetitively curved roof of this loading dock translates an ancient architectural shape—the arch—into today's idiom with modern lightweight fir plywood components.

The floating, airy profile is deceptive. Actually, the roof has extremely high resistance to vertical loading. Construction went fast because of the large size of prefabricated plywood components, and in-place cost was substantially less than thin-shell concrete or a conventionally framed flat roof with the same span.

Capitalizing on fir plywood's high strength and workability, the vaulted roof system offers wide design flexibility through variations in radius, span and number of arches. The distinctive roofline is appearing on more and more schools, commercial buildings and homes.

In this application, 12 bays, 20 x 40 ft., and two half bays shelter 48 loading stations along a 260-ft. conveyor platform. Vault supports are beams and steel columns. Roof components are 4 x 13-ft. curved stressed skin fir plywood panels, used in pairs (spline jointed at midpoint of the vault) to form an arch with a 16-ft. radius and a 2½-ft. rise.

For basic design data on fir plywood or information about fir plywood components, write to Douglas Fir Plywood Association, Tacoma 2, Washington. (Offer good USA only.)



ALWAYS SPECIFY BY
DFPA TRADEMARKS



Truscon Series 138 Double-Hung Steel Windows, fixed picture windows, and screens are an income producing feature of 3440 Lake Shore Drive Apartments, Chicago, Illinois. Architects: L. R. Solomon and Associates. Contractor: Lloyd's Builders.

BEST KITCHEN BUY FOR APARTMENT BUILDERS—Republic Steel Kitchens. Durable baked enamel in white and in colors ends kitchen maintenance costs, assures tenant satisfaction. Also available in new vinyl on steel cabinets—abuse resistant, high fashion decorative effect. You don't repaint with every tenant move. Dimensionally accurate Republic Steel Kitchens are easy to install. Doors and drawers fit right with no maintenance. You save for the life of the building when you install trouble-free Republic Steel Kitchens. Send coupon for specifications.



BEST WINDOW BUY FOR APARTMENT BUILDERS... TRUSCON SERIES 138 STEEL DOUBLE-HUNG WINDOWS

No other window like it! All-steel, bonderized, finished in lasting baked enamel. Stainless steel weatherstripping, stainless steel balance tapes. Series 138 is the trouble-free window.

Steel construction is dimensionally stable. Window always operates easily, fits right, closes tight. Tenant satisfaction is built in. Weather-tightness makes the Series 138 the ideal window for use with air conditioning—either central or window located.

Series 138 Steel Double-Hung Window can be incorporated into Truscon's VISION-VENT® Window Wall, giving you the ultimate in apartment curtain wall construction. And, Series 138 can be furnished in your choice of color.

Where apartments are in your plans, be certain to see a demonstration of Truscon Series 138 Steel Double-Hung Window. Your local Truscon representative will be happy to give you all the facts. Or, send coupon.



BEST ROOF DRAINAGE SYSTEM FOR APARTMENT BUILDERS—Republic Roof Drainage Products. Republic "K" Gutter in lengths up to 32 feet go up easy, go up fast, go up to stay! Precision manufacturing eliminates bends and bows. And Republic tight galvanized coating stays on to provide years of vital protection. Your Republic roof drainage distributor offers a complete line of everything you need—in galvanized steel, stainless steel, terne, copper, with perfectly matched components. Call your Republic representative, or send coupon for additional facts and specifications.

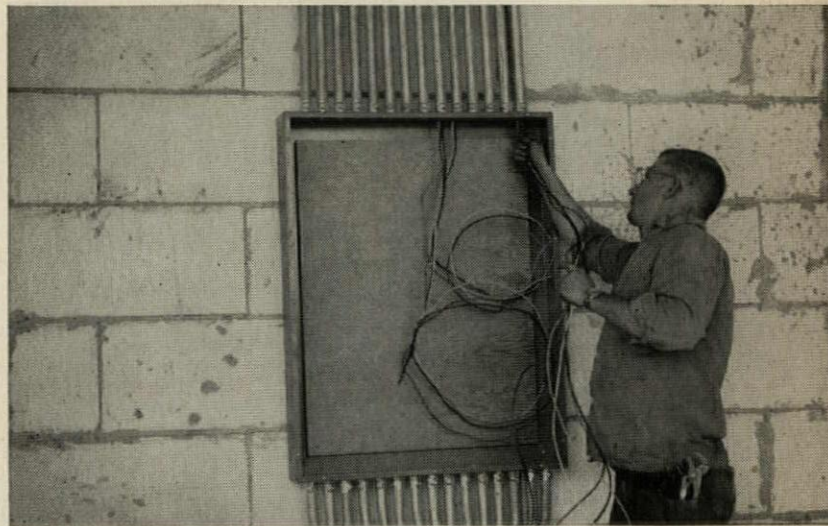

BEST RACEWAY BUY FOR APARTMENT BUILDERS—Republic Electrical Metallic Tubing. Give your building full housepower, now and in the future. Specify Republic E.M.T. in the next larger size and avoid early electrical obsolescence. You will have a grounded, pull-in, pull-out electrical system in which wire can readily be added or replaced. Tenants will enjoy full housepower, whatever their electrical needs for years to come. And, the installation economies of Republic "INCH-MARKED"® E.M.T. allow all this at no greater cost. Ask your electrical contractor for Republic E.M.T. Send coupon for more facts.



REPUBLIC STEEL

*World's Widest Range
of Standard Steels and Steel Products*

REPUBLIC STEEL CORPORATION
DEPT. AF -9193
1441 REPUBLIC BUILDING • CLEVELAND 1, OHIO

Please send more information on the following products:

- Truscon Series 138 Steel Double-Hung Windows
- Republic Steel Kitchens Roof Drainage Products
- Republic Electrical Metallic Tubing

Name _____ Title _____

Firm _____

Address _____

City _____ Zone _____ State _____

Acme

... the **practical** approach to



The First National City Bank of New York
... International Airport Branch



International Showcase of and comfort

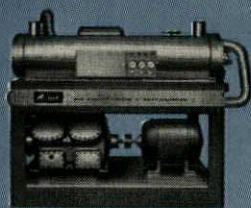

*Tested and certified
package chillers*



*Single and multi-zone
air handling units*



*Cooling towers and
evaporative condensers*

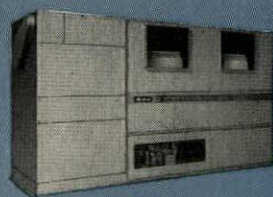

*Self-contained
air conditioners*

Designed for the "Jet Age" by Skidmore, Owings & Merrill, this striking new First National City Bank Branch is located, appropriately, at New York's International Airport. And with its clean, modern architecture . . . its spaciousness, lighting and air conditioning . . . its handsome appointments and up-to-the-minute equipment . . . Citibank's International Airport Branch is truly an impressive showcase of banking efficiency, convenience and comfort.

MANUFACTURERS OF QUALITY AIR CONDITIONING
AND REFRIGERATION EQUIPMENT SINCE 1919

air conditioning



banking efficiency, convenience ... conditioning (by *Acme*)

Headlining the comfort story . . . air conditioning by Acme. It's a story that rates headlines, too. Start with the fact that, per dollar invested, Acme-system equipment delivers the best return in cooling capacity and efficiency on the market today.

Then consider a few of the many other Acme advantages...*compactness and light weight*, saves valuable floor space, reduces building structural requirements (a case in point: installation at

International, where Acme's unit was one of few that would fit into space available) . . . *factory "packaging"* eliminates on-the-job assembly, cuts installation costs . . . *easily accessible controls* facilitates inspection-maintenance, keeps service time and expenses to a minimum.

Finally, a suggestion . . . get the whole story. Acme advantages are easy to prove . . . proof is readily available from your nearby Acme sales engineer.

Acme INDUSTRIES, INC.
JACKSON, MICHIGAN



Allowing wood to function structurally *and* decoratively helped realize significant economies in the construction of this modern church. These dramatic supporting members are 2x6's over laminated arches. Sargent, Webster, Crenshaw and Folley, architects.

Because it brings its own beauty to basic design . . .

for new answers . . . look to **WOOD!**

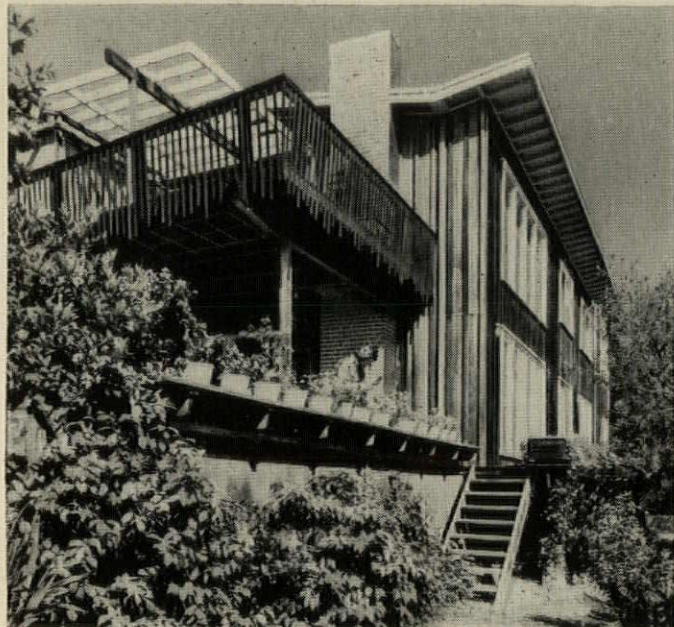

The natural beauty of weathered wood helps wed this house to its site, harmonize with masonry and painted surfaces. Battens create a strong design line. Ernest Born, architect.

Wood's beauty goes to the very heart of a design problem, because it rests on a strong foundation of structural integrity. When you designate wood, you have a material that functions on two levels . . . structural and decorative . . . *simultaneously*. Any material that can perform this double duty is the welcome ally of today's inflation-harassed architect!

For example, wood's use on exteriors . . . its ability to weather subtly, beautifully, even as it protects and insulates . . . the ease with which it harmonizes with so many color schemes. In interiors, wood construction need not be hidden. Rather, you can boast of its beauty with exposed post, plank and beam . . . with floors, paneling and handsome built-in cabinetry. For more information on designing with wood, write to:

NATIONAL LUMBER MANUFACTURERS ASSOCIATION
Wood Information Center, 1319 18th St., N.W., Washington 6, D.C.

nlma

for freedom of design, look to **wood**

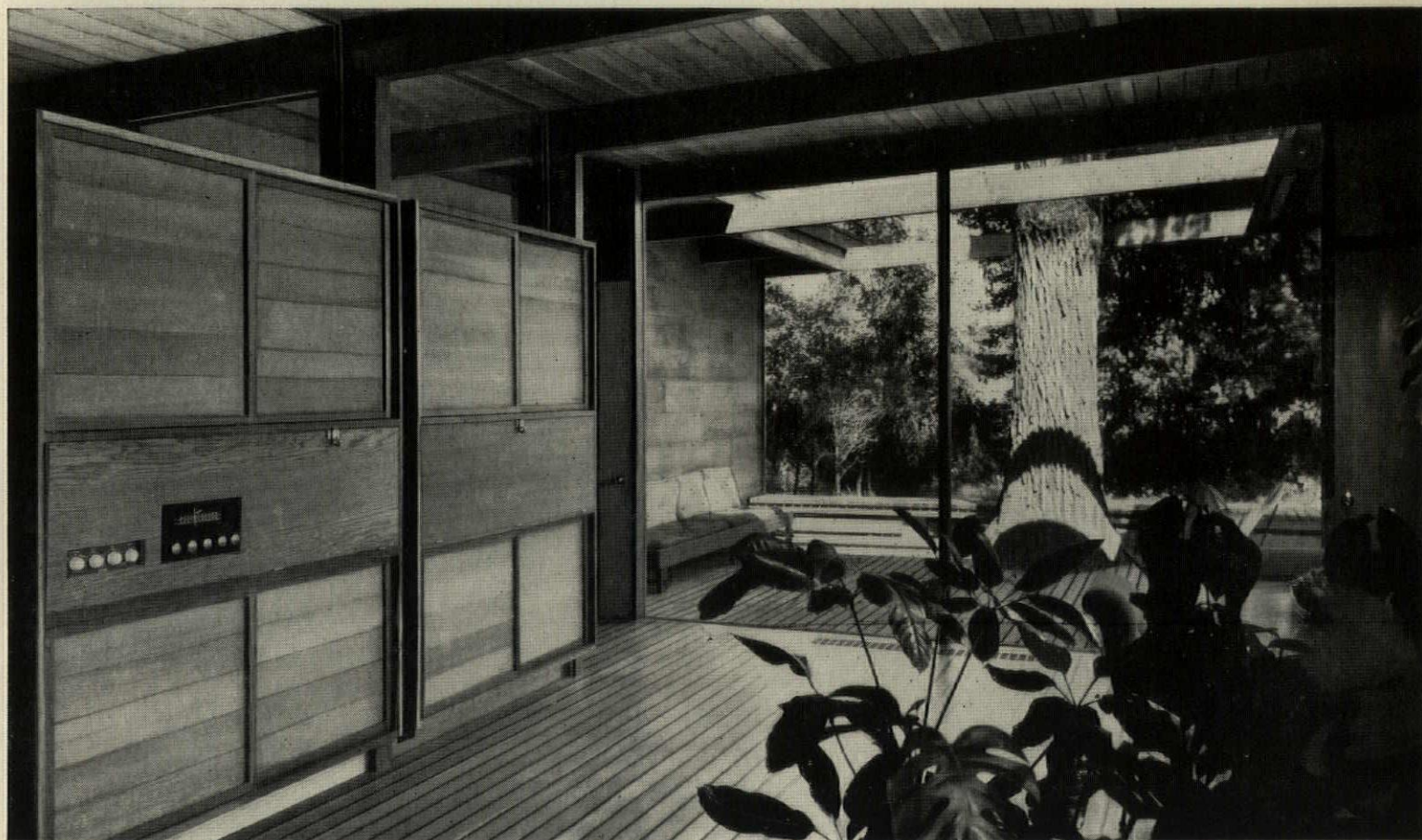

Wood's capacity for capturing the color of Nature, plus its ability to withstand the elements, makes it the logical choice for the architect trying to bridge the gap between indoors and out. Wood's acoustical properties enhance the richness of high-fidelity sound in this modern home. Schweikher & Elting, architects.

SANDWICH CONSTRUCTION MAKES ERECTION OF 100 SQ. FT. PANELS QUICK AND EASY

1 MINUTE ▼

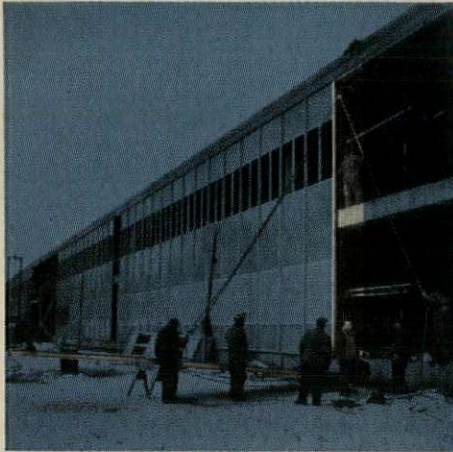

5 MINUTES ▼

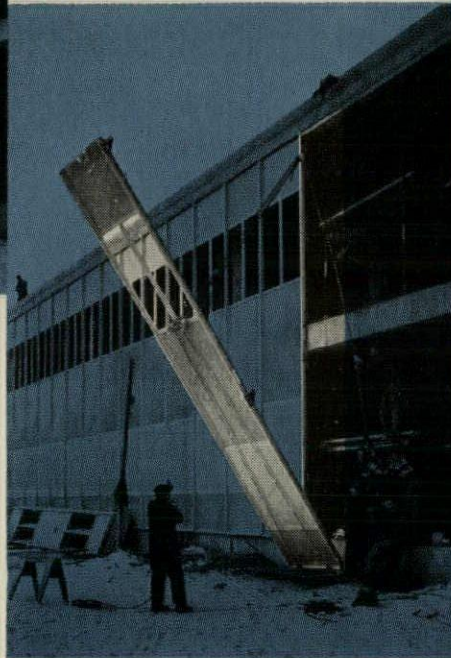

12 MINUTES ►



5' x 20' = 12'

URETHANE FOAM

adds new dimensions
to curtain walls

In just 12 minutes, a 5-ft. by 20-ft. factory engineered panel is raised, positioned, interlocked and anchored into place! This is dramatic proof of the newest advance in curtain wall design made possible by the materials of modern chemistry.

These tongue-and-groove, metal panels—with their self-bonding cores of polyurethane foam—are light in weight, easily handled, made in sizes up to 100 sq. ft. Thin-wall design allows up to 5% more useable interior space. The stressed-skin panels stay flat; will not buckle or warp under temperature and weather extremes.

The urethane foam core is self-extinguishing; is permanently bonded; an integral part of the panel unit; has good dimensional stability and insulation properties. It is an efficient acoustical, thermo and vapor barrier that does not lose its effectiveness with aging.

A REPORT on the use of urethane foam in curtain wall construction is available for your information and evaluation. Write for your copy.

Mobay Chemical Company
Dept. AF-1 Penn Lincoln Parkway West
Pittsburgh 5, Pa.

Mobay is the leading supplier of quality chemicals used in the manufacture of both polyether and polyester urethane foams.

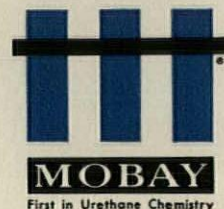

EDITOR-IN-CHIEF: Henry R. Luce
 EXECUTIVE ASSISTANT: Albert L. Furth
 PRESIDENT: Roy E. Larsen
 EDITORIAL DIRECTOR: Hedley Donovan

EDITOR
 Douglas Haskell, AIA

MANAGING EDITOR
 Joseph C. Hazen Jr., AIA

ART DIRECTOR
 Paul Grotz

ASSOCIATE EDITORS
 David Allison, Peter Blake, AIA,
 Russell Bourne, David Carlson,
 Jane Jacobs, Walter McQuade, AIA,
 Richard A. Miller, AIA,
 Ogden Tanner, AIA, Stephen G. Thompson,
 Mary Elizabeth Young,
 Richard Saunders (Washington),
 Allan Temko (West Coast)

ASSISTANT TO THE EDITOR
 Mary Jane Lightbown

RESEARCH STAFF
 Mireille Gerould, chief;
 Benita Galanti, Joan Mebane,
 Kip Mueller, Anne Peyton

ART STAFF
 Ray Komai, associate art director;
 Martha Blake, Charlotte Winter,
 associates; Peter Bradford, assistant

EDITORIAL ASSISTANTS
 Anne Le Crenier,
 Henry Martin Ottmann,
 Ann Wilson

CONSULTANTS
 Miles L. Colean, FAIA
 Lawrence Lessing

PUBLISHER
 Ralph Delahaye Paine Jr.

GENERAL MANAGER
 Charles B. Bear

ADVERTISING DIRECTOR
 S. C. Lawson

ARCHITECTURAL FORUM
 Published by TIME INC.

Editorial

The awards game

This month in San Francisco, at the annual convention of the American Institute of Architects, 16 architectural firms will receive citations for their work through the annual Honor Awards Program. They are to be congratulated. Such competitions have some value: the winning buildings get shown in newspapers and magazines, and help to set a higher national standard of architecture; and the A.I.A. results, picked by qualified and conscientious juries, excel the usual selections by scratch juries pulled together on occasion by local civic organizations. Eleven of this year's 13 award-winning buildings (other than houses) had been chosen by FORUM, quite independently, as instructive buildings to show in some detail to its readers. And yet the award procedure should not be taken too seriously by either winners or losers.

Here are some of the difficulties that the eminent juries are up against:

First, a building to win must be entered, as in any competition, and meeting the rules is both exacting and a bit costly. Hence, the awards are limited to those having the time, money, temerity, or inclination to submit their work.

Second, it is entirely a matter of chance if jury members have seen any of the actual buildings. Photographs and plans are the chief basis of judgment; and both can conceal as well as reveal. Then, too, as Critic Bruno Zevi has said, photographs are a poor substitute at best in judging *space*, and the quality of the space which architecture creates is, after all, the essential "stuff" of the art.

Third, a competition without categories compares peas and carrots, since the buildings are totally dissimilar in program, budget, ownership, locale.

Surely it is asking too much of a jury, no matter how distinguished, to review hundreds of buildings and come up infallibly with 16 stand-outs. It was cruel of Frank Lloyd Wright to characterize the jury process as "the average of an average by an average." Yet buildings

continued on page 97

LASTING QUALITY for your CLIENTS!



Smooth, uninterrupted lines — free of bolts, hinges and all visible hardware.

Interlocking door frame provides positive light seal.

Framed in the ceiling by a narrow metal band.

Maximum illuminated areas, softly diffused illumination.

Easily installed with time-saving mounting brackets, double-fast screws.

Four basic types fit 101 ceiling systems.

Your choice of 12 shielding media.

Available in one and two-foot widths.

Write to Smithcraft for illustrated catalog and price list of Smithcraft Speedomatic Troffers.

Smithcraft SPEEDOMATIC TROFFERS



Light-conditioning by Smithcraft — America's finest fluorescent lighting

Smithcraft

LIGHTING

CHELSEA 50, MASSACHUSETTS

that are exceptional and therefore controversial must inevitably fall out, leaving a tendency to pick the "first among equals."

Awards of distinction in architecture, like awards for achievement in movies or in beauty—or in journalism—are pleasant, occasionally helpful customs, which will be ever with us. They may inspire, instruct, promote. It is hardly news to say that nevertheless competitions cannot substitute for the independent judgment of enlightened individuals, but this may, in today's publicity-conscious U.S., be worth a reminder.

Farewell to a valued friend

With the death last month of Adriano Olivetti, the Italian manufacturer and civic leader, architecture and the arts lost a great friend. Signor Olivetti was the latest, and in his lifetime the greatest, of the creative Renaissance-type patrons of the arts, and he supported them not as a matter of duty or of prestige, but joyfully and bountifully and with participation, as a man of culture naturally would.

He was president of the Olivetti Typewriter Co., a family enterprise with its chief facilities at Ivrea near Turin. He made a top-rank architectural project out of every factory facility that he produced, and beyond that of the housing, the schools, the recreational facilities, and other civic buildings that he erected for his employees and their community. A high design standard permeated not only the plant but the product; and not only the product but the showrooms, the advertising,

the graphic production, and everything that pertained to Olivetti's enterprises. In the U.S., the Olivetti showroom was a chief ornament of Fifth Avenue; it was designed by the outstanding Milan firm of "Studio Architetti BBPR" (Belgiojoso, Peressutti, Rogers) and was a showpiece for the arts and crafts, notably the sand-sculpture wall of Constantino Nivola. Other showrooms such as San Francisco's, by Designer Leo Lionni and Architect Giorgio Cavaglieri, won wide acclaim.

Olivetti did more than set a fine example in the arts; he was aware of the importance of art propagation. All architectural and planning publications in Italy that had any standing were aided by him financially, and he founded an international art journal named *Sele Arte* and an international architectural one, *Zodiac*. Two other, nonart, publications mirrored his other extensive interests: *Technica et Organizzazione* his industrial ones, and *Comunita* his social ones. (He set up the National Institute of Town Planning, and established small factories in more than 65 communities, many of them rural, operated wide-ranging employee benefits, set up his "Community Movement" to battle Communism, was elected mayor of Ivrea, and a member of the Italian Chamber of Deputies.)

Olivetti was probably a sharp bargainer in a business deal, and he was a showman. American planners and architects who attended an Olivetti-organized conference, in 1955, of Italian and American professionals, remember being impressively conducted through the Naples Olivetti establishment by the sturdy

Roman-browed figure in a snow-white suit, attended by a photographer as potentates were once attended by court jesters. Such little vagaries merely rendered the more appealing Adriano Olivetti's massive concern with the whole range of values of today's cultivated man.

Architecture will long and gratefully remember him.

The winner: San Francisco

There is a familiar saying that every man should be allowed to love two cities—his own and San Francisco. We love San Francisco, and we are happy she is no longer coasting on her climate and her cable cars. In a wave of new building, she has begun to rediscover herself: painfully through the automobile which is slashing her proud bay views and swallowing her parks, joyfully in new buildings that portend a whole rich architectural Renaissance.

But it is in her biggest downtown project, perhaps, that San Francisco stands to learn the most about herself. Unlike some cities that have allowed their "Gateways" and "Centers" and "Miracle Miles" to shape themselves, San Francisco has carefully studied its own Golden Gateway project, and then thrown it open to a design competition that has attracted some formidable teams indeed (see page 112). The breadth and clash of ideas, some offering highly original translations of San Francisco, can only benefit the final result. And the concepts—including the concept of a competition itself—might suggest to other cities some new approaches to urban life.

San Francisco's



changing cityscape

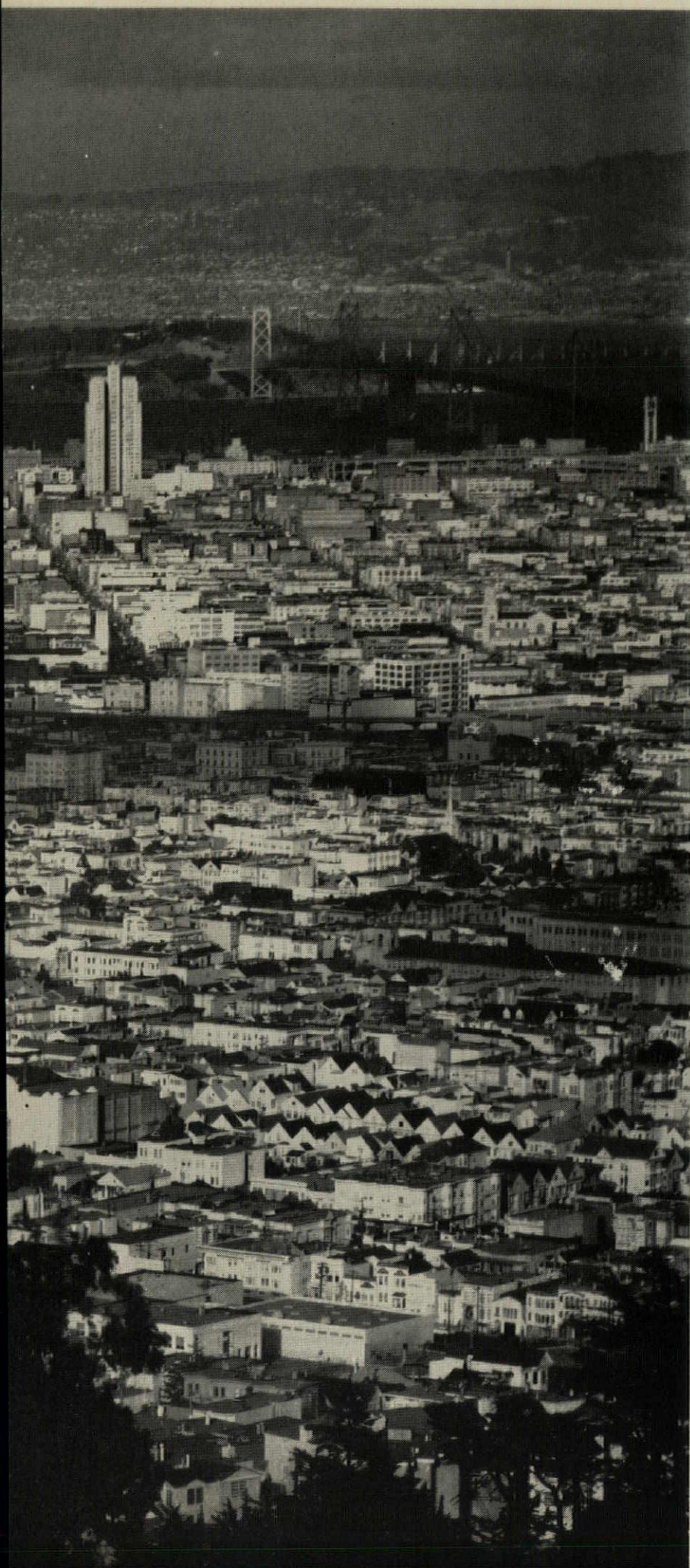

Although some of the old city's charm may have been sacrificed to the local building boom, sensitive planners and aroused citizens are coming to the rescue.

BY ALLAN TEMKO

The cable car, dipping over Nob Hill, rushes downward as the panorama of city, bay, bridge, and sky unfolds in every direction. San Francisco stands gay and brilliant on its hills, burnished by sunlight, compact, intense, proudly cosmopolitan—the most pleasant of American cities. Towers rise at all levels of the terrain, massed together downtown, standing isolated on the slopes and hilltops. Those at the crests lift nearly as high as the great skyscrapers of New York, commanding a port whose sweeping grandeur is rivaled only perhaps by the beautiful bay of Rio de Janeiro. For almost 50 miles to north and south, where it is lost in golden haze, the harbor unites the regional metropolis of the 3.5 million people who live on its shores in a territory almost as large as New Jersey. And because this is the Far West, with its tremendous open space and wonderful light, the whole scene can go crimson at sunset.

To find so powerful a modern metropolis in such a setting, almost Latin in mood but plainly American in vigor and enterprise, is a stroke of luck in this age of urban crisis. If renewal can succeed anywhere, it should here, in a city which is not only young and blessed with natural beauty, but was also, like a fortunate person, born to wealth. An almost incredible treasure was carried down from the mines during the first years of the city's existence, and wealth has been accumulating in the great banks and commercial houses of downtown ever since. Today the per-capita income of more than \$2,600 a year is among the highest in the country.

This prosperity is reflected in the city's *savoir vivre*: its easy but elegant manners, its appreciation of food and wine, its support of the arts, its deep-rooted, but scarcely slavish, sense of history. Apollo, protector of cities, has been exceptionally kind to San Fran-

cisco, a city which is dear to the sun.

Yet when the Philadelphia urbanist Aaron Levine was invited last year to criticize San Francisco's lagging renewal program, he could speak of "euphoria," and warn that, when cities go, they go fast. The note of urgency was justified, for, although it had been clear to the city's able planners immediately after the last war that San Francisco was "badly run-down at the heels," more people were living in slums today than in 1945, and blight was spreading.

Nevertheless, the redevelopment program seemed hopelessly stalled. Three major projects, the great Golden Gateway scheme to replace the obsolete produce market, and the smaller but ambitious projects for Western Addition and Diamond Heights, all model enterprises which dated back to 1956, 1951, and 1949, respectively, were tied up by red tape, litigation, and—most important—apathy, incompetence, and even venality at high levels in the municipal government. A scandal erupted at City Hall, resulting in the resignation of the mayor's principal aid, who owned stock in a syndicate dealing in slum properties; federal officials impatiently started an investigation of the city's "slowness"; the general outlook appeared so dark that FORUM only last September described the city's renewal prospects as "poor."

Complacency abandoned

Today the situation has changed so dramatically, and the city is proceeding so impressively in other sectors of the urban struggle, that San Francisco's experience can stand as an object lesson for the rest of the nation. Land acquisition has been virtually completed in the Western Addition, and is already complete on Diamond Heights, and proposals from developers are being considered. For Golden Gateway, in an effort to ensure high architectural quality based on a philosophy of humanism that goes "beyond the expected returns to investors," the city is conducting one of the great urban design competitions of modern times (page 112).

If any single man is responsible for

this remarkable turn of events, it is M. Justin Herman, former western administrator of the U.S. Housing and Home Finance Agency, who, after prodding, cajoling, and threatening the city for eight years in an effort to spur it to action, was finally asked to assume direction of the redevelopment agency, and do the job himself. That few men could do as brilliantly, he has demonstrated in only eight months.

Yet Herman's success in salvaging the sinking renewal program is only a symptom of a profound change for the better in San Francisco's urban health. Not only the city's gifted architects and planners, as well as enlightened officials and businessmen, but the populace as a whole, shocked into recognition that the very future of San Francisco is at stake, have abandoned complacency. Never before have San Franciscans, who are not quick to find fault with their city, been so concerned by the fate of their surroundings.

Menace of the automobile

They have reason. The tasks confronting San Francisco, as it strives to preserve and enrich its historical *cachet*, clear its slums, and defend itself against the automobile, are staggering. More than \$100 million of new construction has been recently completed, and no less than \$500 million more is to be spent in the next few years. But even if all the work contemplated is actually carried out, more will remain to be done.

In spite of its jaunty, bay-windowed charm and occasional real elegance, the city which was hastily rebuilt after the disaster of 1906 has aged with tragic swiftness. Abject tawdriness typifies streets as important as Market and Kearney; and spacious Van Ness Avenue, a potentially magnificent boulevard, passes between the Beaux-Arts monuments of the civic center to become a nightmarish automobile row.

The auto menaces the city everywhere, as was painfully revealed by the demolition of the Montgomery Block of 1853, the most precious momento of the pioneer community. Long a home of artists, it could easily have been brought into the group of splendidly



Jackson Square (above), "a group of splendidly renovated early structures." Portsmouth Plaza (below), "to be undermined for a garage unless a citizens' law suit succeeds in blocking it."



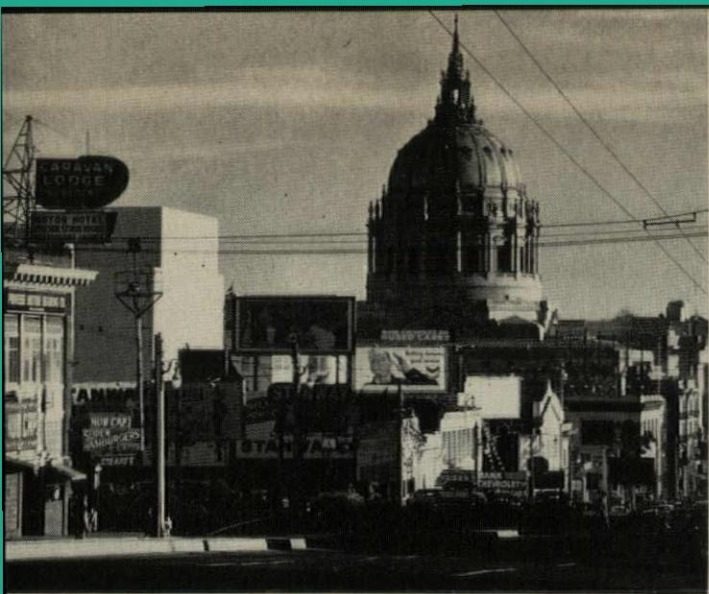

1

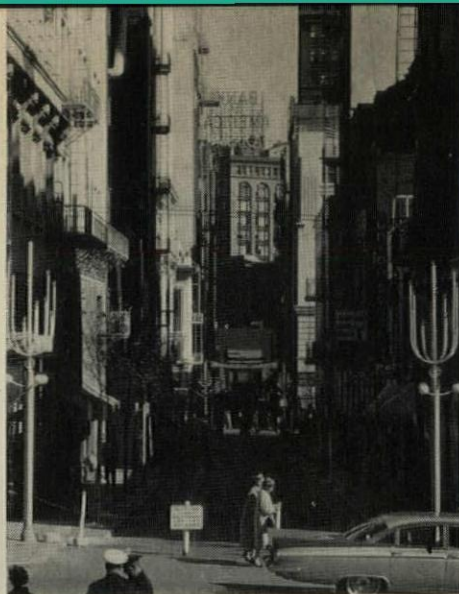

2

3

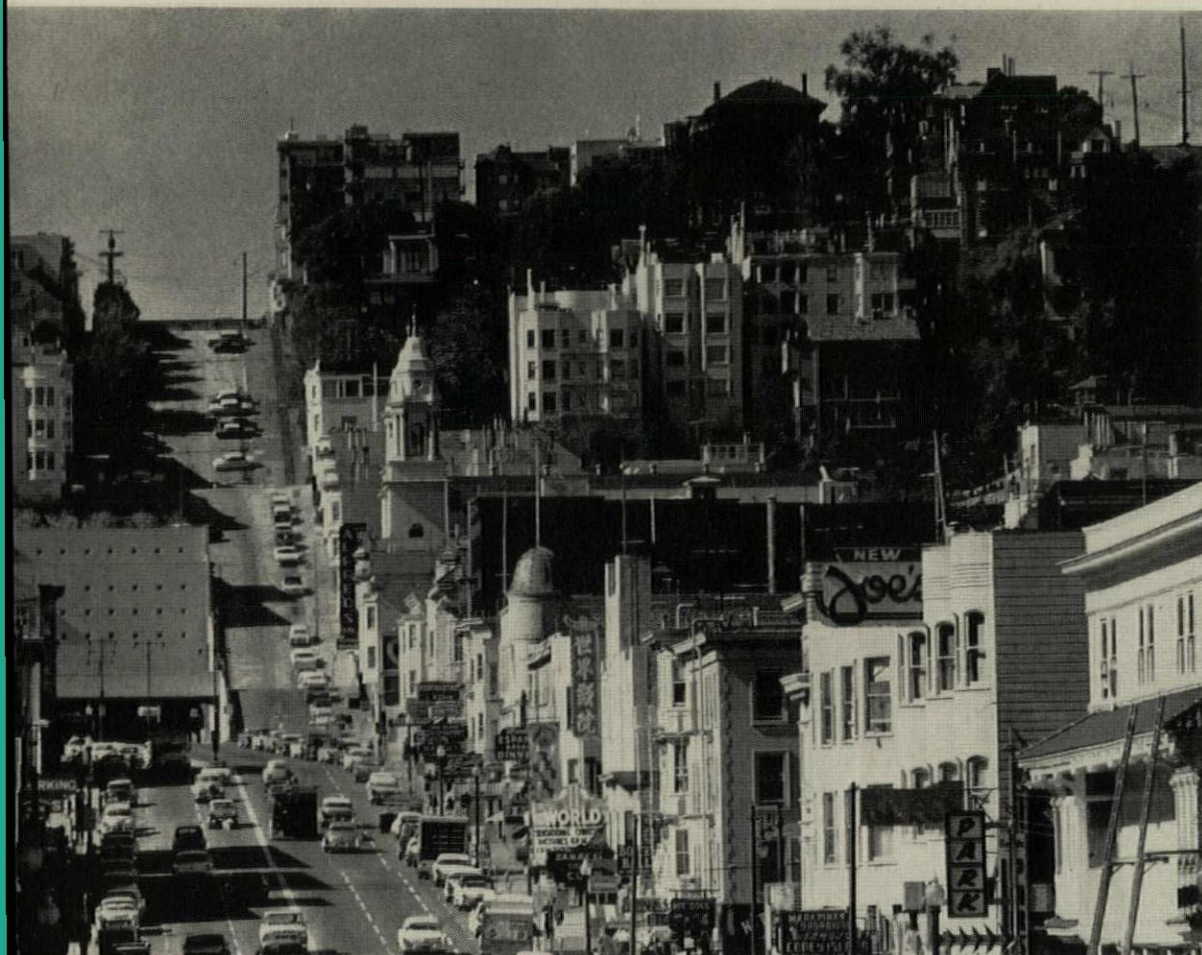
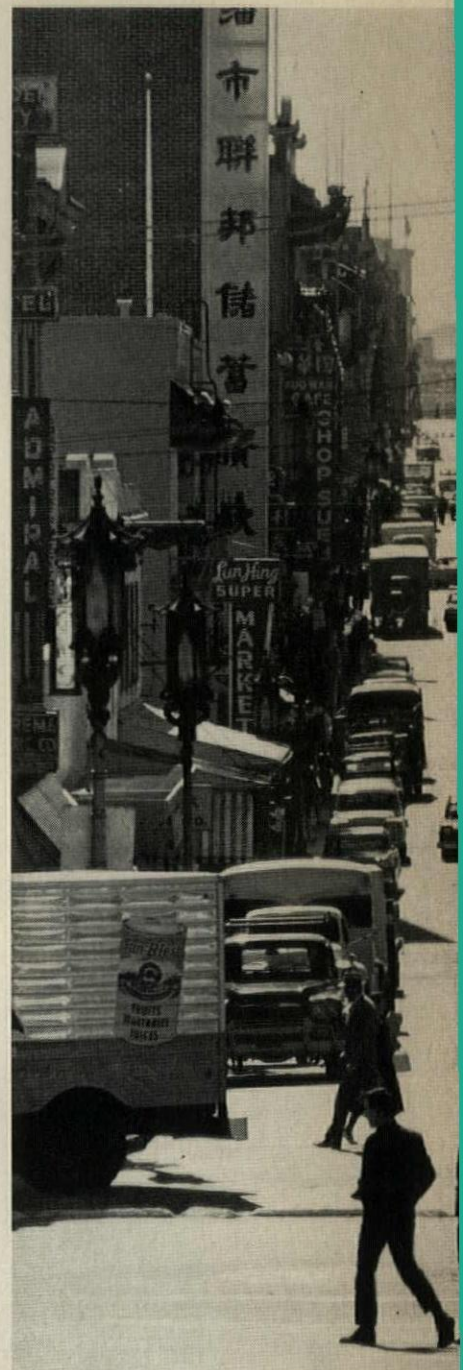

4

PHOTOS: RONALD PARTRIDGE

5

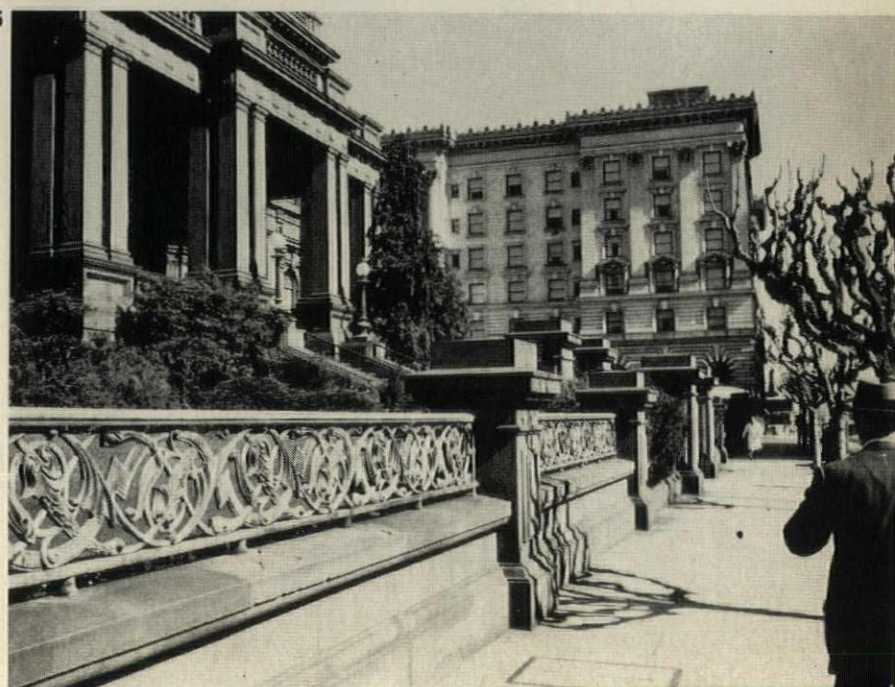

THE OLD CITY

1. Below the civic center dome: Van Ness Avenue, "potentially magnificent, actually a nightmarish automobile row." 2. Maiden Lane, "a little street overpublicized, overpraised, and overdecorated." 3 & 4. "Abject tawdriness typifies San Francisco's streets": Broadway at Russian Hill, and Chinatown. 5. Nob Hill's noble Pacific Union Club and Fairmont Hotel.

renovated early structures of Jackson Square, but it was leveled to make room for a parking lot. Throughout downtown, block-busting garages have sprouted up to accommodate as many as possible of the 630,000 cars which enter the city on a typical business day, and the parking authority has come to regard the subsurface of every public square as a possible underground storage space. Yet, no matter how adroitly these squares are transformed, they are never quite so sympathetic again. Something indefinably valuable is lost when the natural contour of the city, with its depth of earth and rock, is replaced by a suave terrace of concrete. Union Square and St. Mary's Square have already been thus undermined, and the turn of Portsmouth Plaza, where Old Glory was raised over the city, will come next unless a citizens' law suit, claiming violation of the city charter, succeeds in blocking its conversion.

Perhaps even more fateful for the city has been the plan of the state-highway engineers to run a network of freeways over the hills, dismembering San Francisco as Los Angeles has been dismembered. Thanks to public indignation, which here for once has been effective, the program was checked and is now being reconsidered. Yet it was not checked before the system had forked into downtown, directing one prong at the civic center and jamming another double-deck expressway down the Embarcadero, ruthlessly cutting in front of the old Ferry building at the foot of Market Street, and robbing the water front of sunlight and the famous bay views.

Cause for hope

"Progress usually means giving up something worth-while for something less attractive," the *Chronicle* ruefully quoted Architect Edward Durell Stone, and recommended that the freeway be torn down. Yet at the same time, casting a critical eye over the city, the newspaper also saw cause for hope: a prodigious display of civic responsibility by the Crown Zellerbach Corp. Eighty years before, the company had

started as a stationery store in a basement; it now wished to pay a debt of gratitude to the city which had helped it become a wood-products empire with holdings from Canada to Mexico.

The gesture was handsome. Soaring 20 stories as a transparent enclosure of green glass, the company's new headquarters building created a magnificent gift of urban space, carved from what had been a declining waste on lower Market Street. Only one-third of the triangular, parklike site—certainly a local record for urban land use—is occupied by the tower, which lifts two stories free of the ground on 18 formidable columns that ascend the full height of the structure as its only vertical supports. Elevators and other utilities are housed in the massive service shaft which flanks the southern façade.

Whatever the shortcomings of the concept (the unprotected glass façades, to name one obvious weakness, suffer severely from sun), this far-western cousin of Inland Steel and of Lever House nevertheless deserves comparison with the serious architecture of its time—a claim which hitherto could not be made for any tall building in San Francisco, including the elephantine, white Equitable of 1955. Together with the nearby John Hancock Building (page 104)—so profoundly different although it too was designed by Skidmore, Owings & Merrill and completed about the same time—Crown has inaugurated a new phase in the city's development which the Chamber of Commerce has dubbed "The Big Build."

By the standards of any city, the build is big, even though none of the major structures would attract much notice if deposited in the Manhattan sky line. The tallest planned so far is a 30-story luxury apartment house on Russian Hill, which John Bolles is designing for William Zeckendorf. Probably the most ponderous will be the \$50 million Federal Building, a 20-story block that will dominate the north side of the civic center. Perhaps the most ill-advised is the 22-story shaft by Mario Gaidano—a fair enough design in itself—which Owner Ben

continued on page 232

"A double-deck expressway down the Embarcadero, ruthlessly cutting in front of the Old Ferry Terminal, robbing the water front of sunlight and bay view."

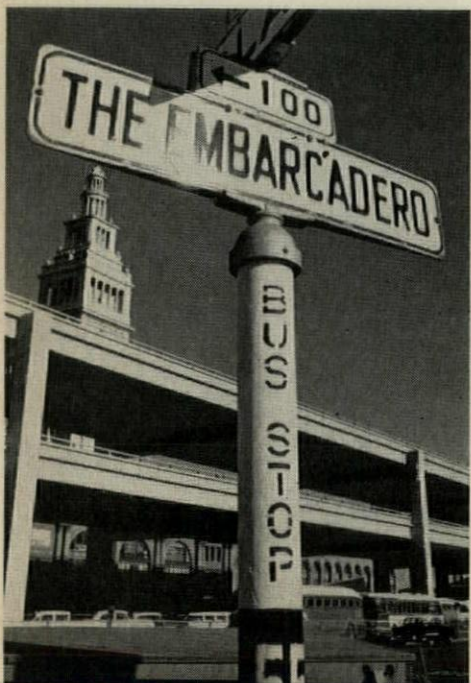

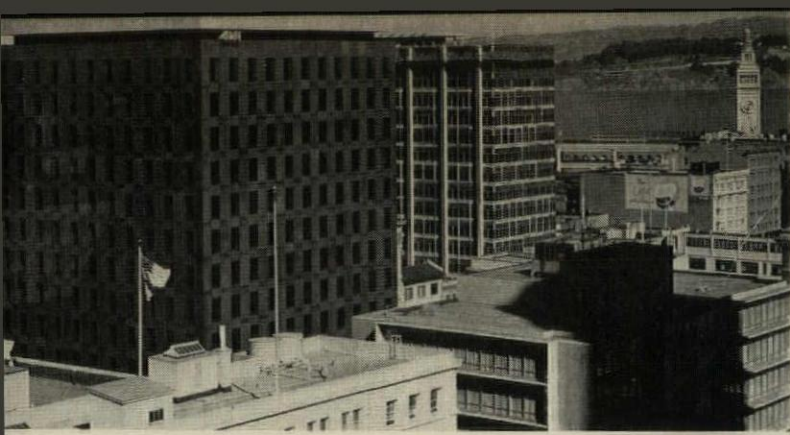

1



2



3

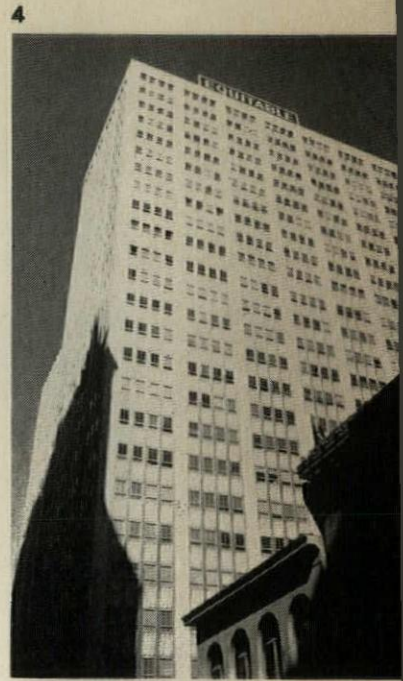

4

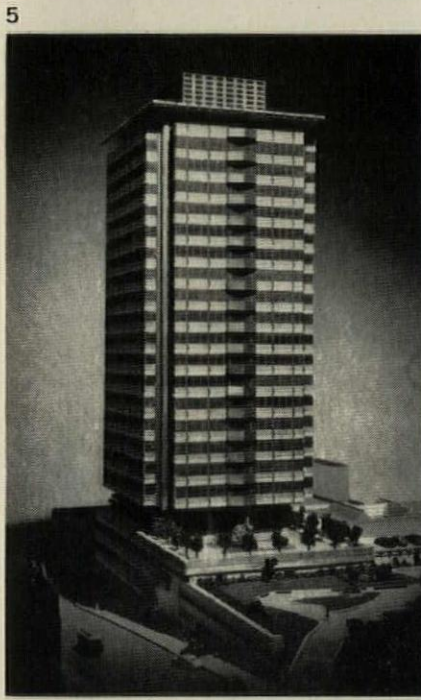

5



6

THE NEW ADDITIONS

1 & 2. "The strength and sobriety of John Hancock's dark granite inaugurates a new phase in the city's redevelopment." 3. Crown Zellerbach, "a magnificent gift of urban space, but vulnerable to sun." 4. The Equitable Building, "elephantine and white." 5. The American President Lines project, "a glittering shaft of white and gold." 6. The Bethlehem Steel Building, "garish rather than dignified." 7. St. Mary's Square garage, "something indefinably valuable is lost when the natural contour of the city is replaced by a suave terrace of concrete."

7



(3) MOSS PHOTOGRAPHY; (5) DEAN STONE & HUGO STACCATI; (OTHERS) RONALD PARTIDGE

San Francisco's newest tower

As a western development of a Chicago style, the John Hancock Building enriches San Francisco's romantic architectural continuity.

BY ALLAN TEMKO

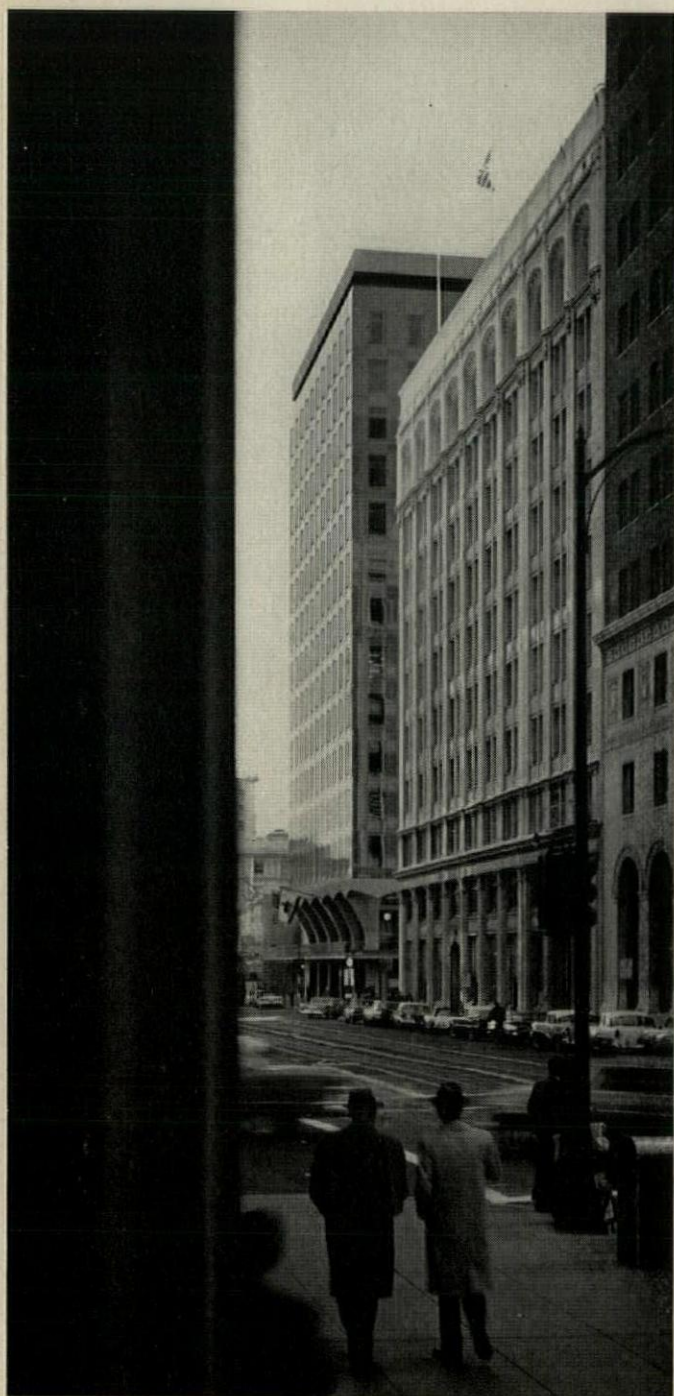

Black and solid in the sunlight, responding eloquently to sky and weather, the John Hancock Building is a romantic creation for a romantic city, in which it could not be more at home. Indeed, this western headquarters for a conservative Boston insurance company has taken its place in San Francisco's vigorous financial district with such imaginative tact, and such refreshing freedom from modernist dogma, that it can scarcely be appreciated except in the context of the cityscape (see page 98). This is perhaps the first measure of its excellence.

Whatever its other virtues—which include a happy recollection of the uninhibited early skyscrapers of Louis Sullivan—Hancock is first of all a brilliant urban concept. Although at only 14 stories it plays a powerful role in the sky line, Hancock has been designed primarily to be seen by the pedestrian approaching through the busy downtown streets, past the formidable banks, steamship lines, exchanges, insurance companies, and corporation headquarters which for blocks present massive and continuous façades (1).

If few of these old buildings are truly distinguished, taken en masse they nevertheless constitute an admirable urban scene. Beaux-Arts monuments, laden with classical orders, rise on two-story colonnades or arcades that provide them with imposing entrances and interiors; and, like Renaissance palazzos, they are capped with strong cornices which enable them to meet the sky with unmistakable finality.

To the credit of Hancock's architects (who, although this may seem astounding to those familiar with the firm's other work, are the San Francisco office of Skidmore, Owings & Merrill) it was decided to accept the historical challenge of California Street as an opportunity rather than a handicap. Clearly, a street with so firmly established a character presented problems almost as vexing as those which have defeated the contemporary movement on Park Avenue in New York, where S.O.M. and other modernists have been content to remake entirely a handsome existing environment by erecting a series of glass boxes—granted, a few of them extremely elegant boxes. In a city as sun-swept and unconstrained as San Francisco, however, a "New York building" would be even less satisfactory, as S.O.M.'s transparent Crown Zellerbach tower on Market Street has already demonstrated (photo, page 103).

The problem, obviously, had to be completely re-examined; and it is fascinating that the concept developed for Hancock actually harks back to the pioneer period of the modern movement, which after three quarters of a century still remains the most winning moment of office building design in the U.S. Like Sullivan's venerable Wainwright and Guaranty Buildings, Hancock was given a clearly defined base, a middle, and a top. And like John Wellborn Root's grandly sober Monadnock Building, the last triumph of the bearing wall, Hancock also celebrates the strength, calm, and opacity of traditional masonry, but in conjunction with a modern industrial material





—reinforced concrete—to do the structural framing.

If these affinities with the early modern in a sense make Hancock an old-fashioned building, the lessons of the pioneers have been faithfully translated into the new architectural vocabulary of the present. The result is an uncompromisingly experimental structure, suffering some of the *gaucheries* inevitable in such experiments, but with a prodigious originality that can be grasped as soon as its unique arcade of reinforced concrete—drawing the eye past older arcades in the foreground—comes into the pedestrian's view (2).

Quite suddenly, one after the other, the lithe arches are seen springing, logically changing shape as they rise to meet the weight of the granite-sheathed walls of the square tower above, and creating at each of the corners a deep, heraldic recess reminiscent of a neoclassical shield (yet actually dictated by structural needs). Nowhere in the U.S. has concrete been used more cheerfully than in these arches, so precise in outline and warm in texture, given a rose tint by the basaltite aggregate which was bush-hammered and washed with acid to bring out its full tone.

At their crown the arches project outward some 5 feet above the terrace, which breaks their supporting columns in midrise, and provides the key to Hancock's very special role in the city. Not only does the terrace overhang the shop fronts below, sheltering the pedestrian as nowhere else in San Francisco, but it also provides a platform of greenery from which the tower—set well back from the sides of the site—can ascend unimpeded by its neighbors. Thus Hancock has been ingeniously united with the surrounding city at street level, where continuity is welcome, but at the same time rises *solus*, as Sullivan said the tall building must.

The tower, furthermore, lifts with controlled opulence. Even in this city, where less than a dozen towers exceed 20 stories, Hancock does not qualify, at 14, as a "skyscraper." But what it lacks in height it makes up in richness. The plaques of polished Minnesota granite, actually charcoal in color, turn jet when seen as an ensemble in San Francisco's rapidly changing light. The granite makes no secret that it is applied; and thus it is as "honest" and architectonically as valid a device as Mies's largely decorative use of nonstructural metal members to express his fireproofed (and therefore hidden) steel skeletons. The staggered, overlaid pattern of the granite gives a baroque effect of low relief.

The bronze around the windows of course makes the effect richer still, and is admirably in scale: the glass is not framed so much as trimmed (section, right). Moreover, the gray glass has been chosen with care. Its color, in large sheets, approximates that of the stone, and because of the chaste flush mountings the windows appear as a heavy film, rather than as pronounced openings in the wall, enhancing the impression of mass (photo, left). Only at night do the windows blaze forth individually.

Like San Francisco, Hancock is complex, subtle,

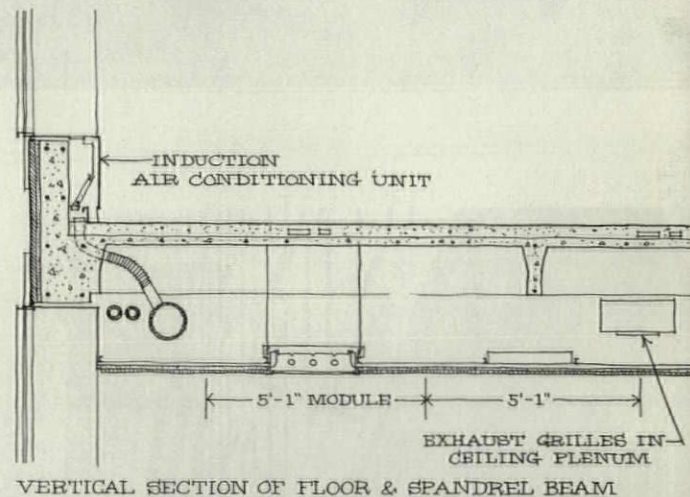
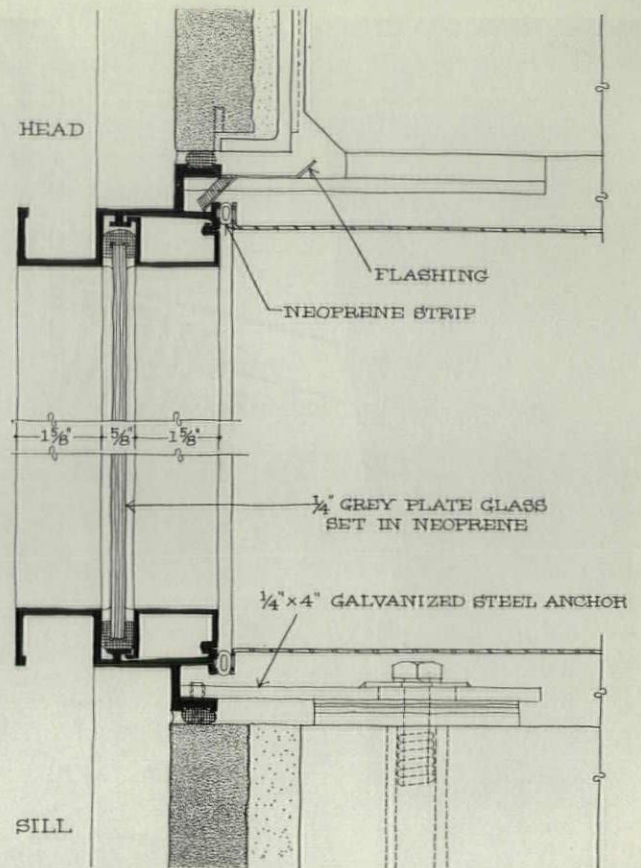

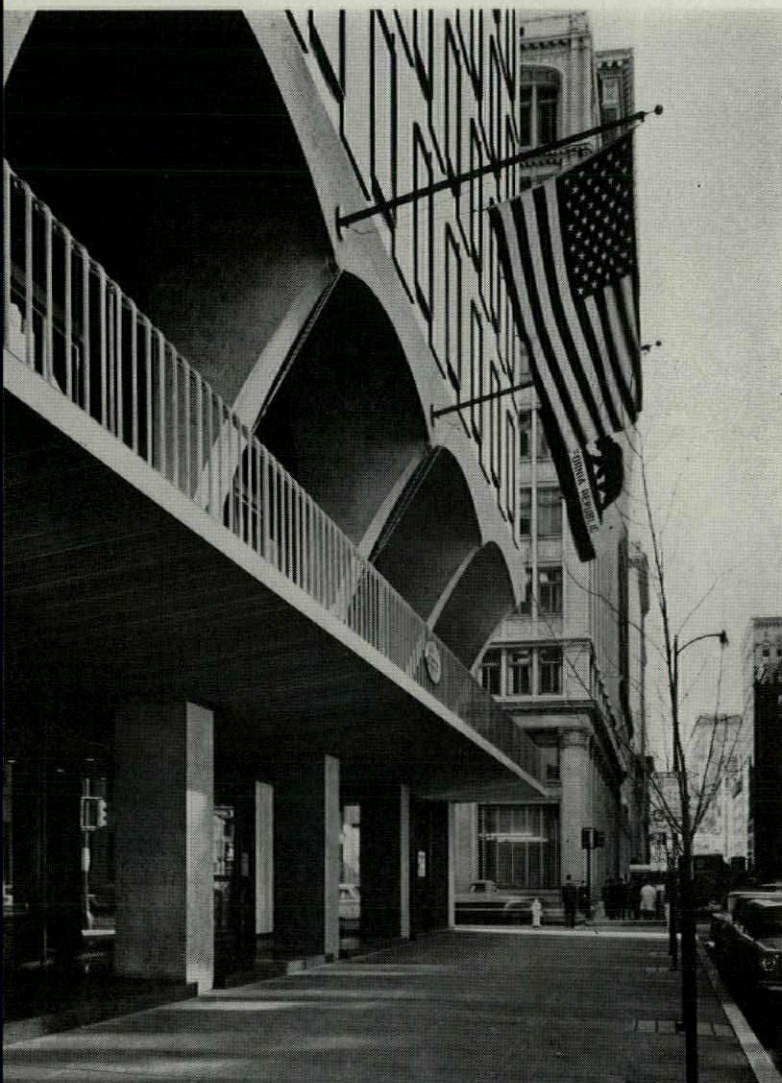
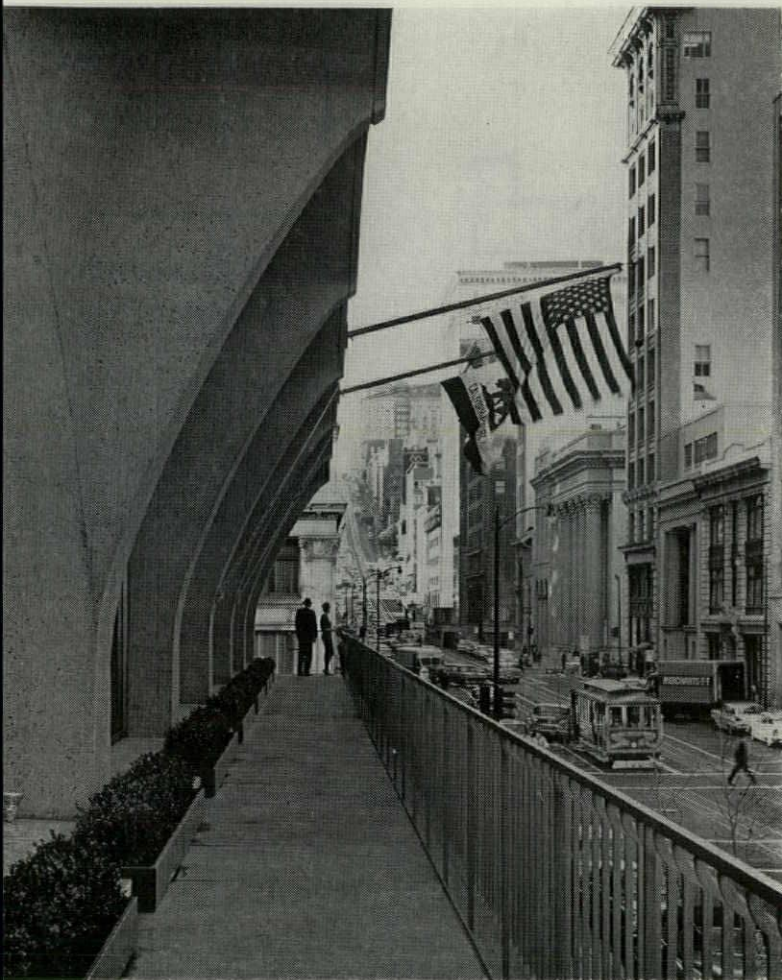

full of unexpected secrets, yet candid. Set in the midst of imitation Florentine palaces, it is truly palatial. With generosity and ingenuity its architects have shown what the best Renaissance designers, if they had been working in a technological age, might have done with industrial techniques and materials, hesitating neither to use stone (which after all is today quarried and polished by machines), nor even to attach the precast concrete panels of the parapet to a roof frame of steel. Structurally, the technique is as justifiable as the hiding of reinforcing bars within concrete; and visually—which is what counts in this building—the effect is handsome.

Hancock, then, is a palazzo of today, transmuted Renaissance ideology into a thoroughly modern idiom, and using classical forms only to obtain richness and diversity. If this is the ground on which the building should be considered, then one may ask fairly if it satisfies Alberti's dictum that the essence of beauty resides in "the harmony and concord of all the parts achieved in such a manner that nothing could be added or taken away or altered except for the worse."

This awesome verse from a bible of architecture is perhaps more dreaded by contemporary designers than by any of their predecessors, and Hancock's architects—as the splendid change of proportions between base, shaft, and summit show—took it to heart. A glance at the terrace, cutting through the arcade across the whole width of the structure, reveals, however, that they have not hesitated to spoil the base for the sake of the over-all concept (3, 4). Both the Renaissance and Gothic masters taught with incomparable authority that a curved line should be allowed to develop energy, so that, at the key of an arch or a vault, it is spent with maximum drama. If this were done at Hancock, the mezzanine floor would have been eliminated, and the entire base of the building would have stood open and lordly. At the very least the first two floors should have been recessed, and the arcade left unbroken.

Although Hancock is a palace, it is a monument of the modern mercantile community and not of a ducal regime, and attends to the economic as well as the esthetic use of space. Hancock was designed with the client's requirements in mind. Although the company needed only one floor for its regional executive office, not an entire building, it did wish to display a corporate image commensurate with its wealth, age, and dignity. How far its building is from being simply a crass money-maker can be appreciated by contrasting it with the Equitable Building only three blocks away, erected by a comparable institution on a comparable corner site (photo, page 103). Equitable is crammed on its lot, rising 25 stories—11 higher than Hancock. It provides no greenery—not even sidewalk trees, such as Hancock's sycamores. It even fails to provide for underground parking, while Hancock accommodates 40 cars in its basement.

Hancock's only mark of identification is its traditional signature on a small oval medallion attached

to the exquisitely wrought bronze balustrade of the terrace just above the main entrance: a far cry from the ludicrous advertising clock on the roof of the Equitable. Nevertheless, everyone knows which building is the Hancock. Not only in the building's monumental appearance, but in the elegance of its appointments, including the greenery, Hancock obtained a corporate image scarcely less impressive than the headquarters of the nearby Crown Zellerbach Corp., which is set in a luxurious private park.

As soon as one moves under the balcony, beneath the flags of the state and the nation hung like Renaissance banners from almost horizontal staves, one realizes that this is a special arcade indeed. The underside of the balcony is finished in strips of teak. The shop windows and doorways are handsomely trimmed in bronze, and the over-all appearance is controlled. There is a clear indication of welcome, a feeling of expectation, as one passes through the triple bay of the entrance. The lobby, however, is a disappointment.

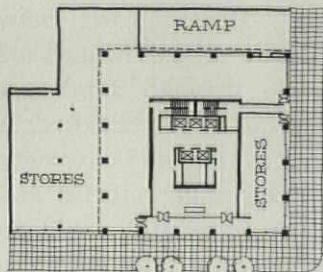

The space which flows through the glazed doorways is abruptly checked—scarcely 10 feet inside the entrance—by the wall of the service core (5). This surface of cream-colored, unfilled travertine might have been less oppressive if it had been left unadorned—as are the rest of the lobby walls where the same classical material is left handsome and discreet in itself. But the entrance wall has been hung with bulky concrete bas-reliefs which are not only woefully out of scale—perhaps two or three times larger than they should be—but also undistinguished. Perhaps these pieces of precast sculpture were meant to symbolize the Hancock's nationwide or world-wide associations, for they include patriotic motifs as well as a fish and a sextant. But in actuality they call attention to the small dimensions of the lobby. Here was an appropriate place for a sitting group but there is not so much as a bench.

As soon as the Hancock suite is reached, the building comes into its own again. The garden with its jetting fountain is immediately seen through the glass doors of the reception room and the glazed archway beyond: a little urban oasis. The lofty, vaulted offices, sweeping around the perimeter of the building, are even more than one expected from outside (6, 7).

Not for some time have spaces like these appeared in a major American office structure. Their close contact between indoors and out—in the heart of the city but above the hurly-burly of the street—is a heartening sign. From every desk, including those of the stenographers farthest from the windows, there are views of the garden and the city through the broad arching bays. There is also a sense of elation in having the ceiling so high overhead. Even small private offices only one bay wide seem to have generous dimensions, because of the vaulted ceilings.

PHOTOS: MORLEY BAKER

5

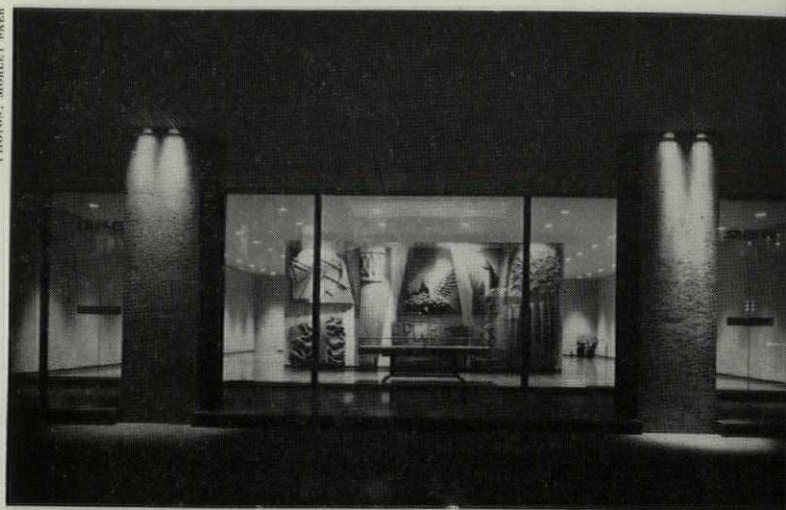

6



7



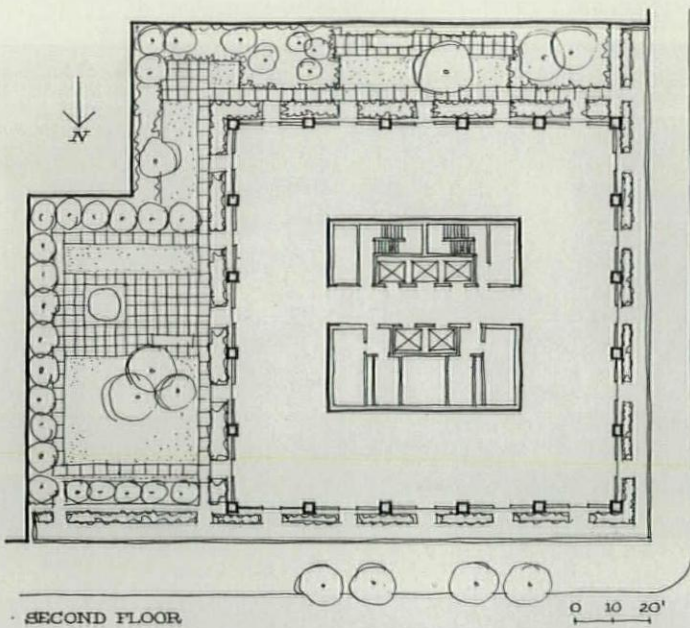

PHOTOS: MORLEY BAEH



8

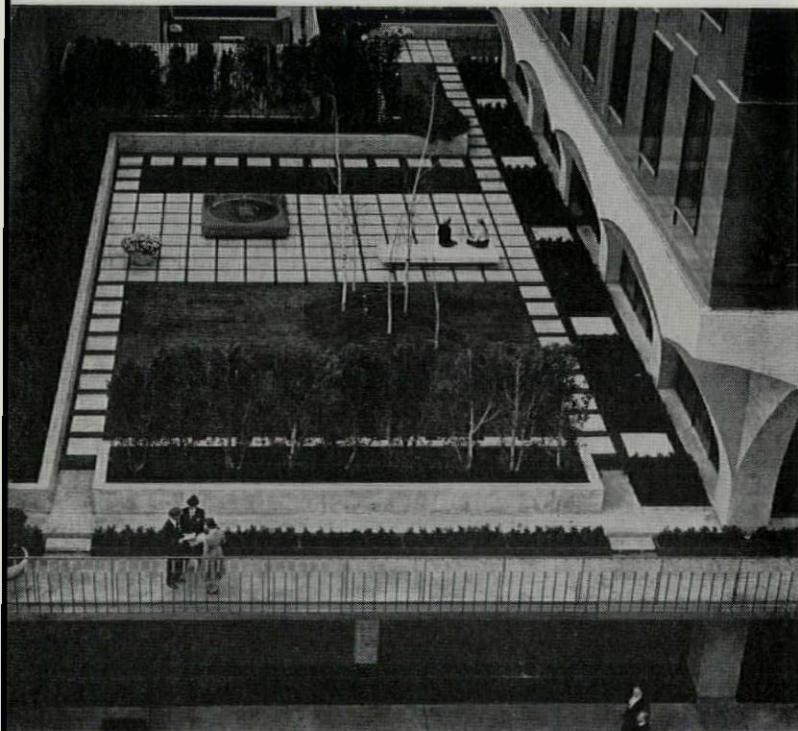

9

The detailing everywhere on this floor is particularly accomplished. The colors are serene: beige, off-white, warm browns; the woodwork is teak.

Outside doors offer a strong invitation to the L-shaped garden (the joint work of S.O.M. and Landscape Architect Lawrence Halprin) which so adroitly enhances the building at the rear of the site, and which is continued, in planters of box hedge, on the balconies overlooking the street. The focal point of the terrace is the little patio first seen from the reception room, with its splashing fountain which was carved at the quarry from a single 8 foot square of the same granite used in facing the tower (8). Grass grows between the concrete paving blocks, which branch off in single files from the patio through small areas of lawn enlivened by birches and sycamores, laurel and wisteria, jasmine, periwinkle, and a variety of other plants (9).

The upper stories are entirely column-free: the plan (opposite) could not be more "Miesian," simplified to a square—the compact central service core placed within the larger square of the exterior walls. Both inner and outer walls are bearing members, and the 32-foot space between them is modular and flexible. The 5-foot, 1-inch module is curious: by adding an inch to the original module they contemplated, the architects found that additional space equal to that of a whole floor could be obtained; and since 14 stories was near the physical limit of the concrete, they decided to go not higher but slightly wider. The cost of custom fabricating ceiling tiles and other standard fixtures was offset by the increased rental income.

On the upper floors one can appreciate the advantages and disadvantages of the window pattern. In comparison with an all-glass tower such as Crown Zellerbach, where acrophobia can result if one moves too close to the transparent wall, Crown's intermittent pattern of solid and void is reassuring. Yet a tower should grow lighter and more open as it ascends, and this is something that Hancock, a classical building, does not do. Could the upper portions of the building have been given a treatment as revolutionary as that of the base? Perhaps. But the chance, if it exists in a building of this kind, was not seized upon. Perhaps it will be, in the building which next picks up the thread—one of the most essential threads in the many-colored fabric of modern architecture.

The significance of the Hancock building to modern architecture should not be underestimated. That its architects have turned from their Miesian doctrine is alone an architectural event of some importance, in view of the stature of the firm and its unswerving allegiance to Mies's design precepts for more than two decades. Hancock also marks the emergence of Edward Charles Bassett, S.O.M.'s 38-year-old chief designer in San Francisco, as an unusually gifted architect. Perhaps it is no accident that S.O.M. has been the light of romance, for the light is San Francisco's, catching the square, black, powerful structure which overlooks the Bay.

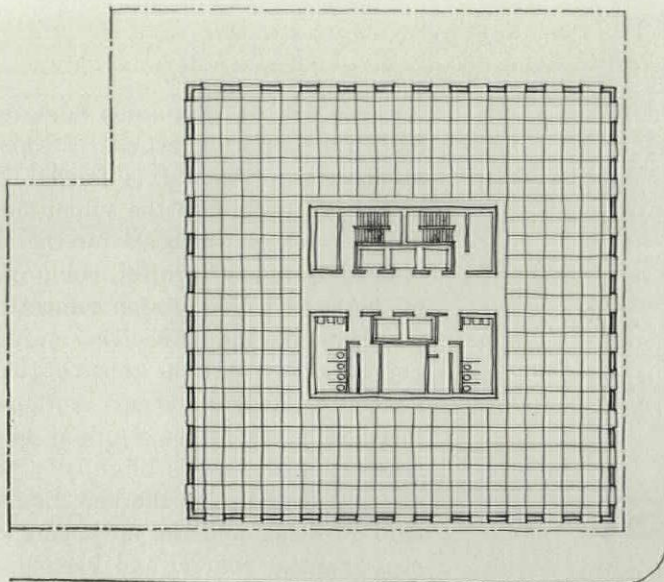

TYPICAL FLOOR

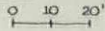

JOHN HANCOCK WESTERN HOME OFFICE BUILDING, *San Francisco, Calif.* ARCHITECTS & ENGINEERS: *Skidmore, Owings & Merrill.* LANDSCAPE ARCHITECT: *Lawrence Halprin.* GENERAL CONTRACTOR: *Cahill Brothers, Inc.*



San Francisco's \$100 million contest

From the keenest design competition yet in urban renewal, the city will choose one of these nine schemes for its big "Golden Gateway" project.



CARROLL MULLIN

After years of discussion and delay, San Francisco's biggest concerted effort at downtown renewal is finally under way this month with the submission of nine competing proposals for the city's "Golden Gateway" project, result of one of the largest civic design competitions yet held in the U.S. The unjudged entries, shown with the assent of the San Francisco Redevelopment Authority*, cover 20 acres of an eventual 44-acre renewal of the city's blighted produce district, bounded by the new Embarcadero Freeway and the advancing business-financial center, and blessed with sweeping views of the bay, bridge, and Berkeley hills beyond (see photo).

Requirements of the official redevelopment plan, which should involve well over \$100 million of improvements, included 2,200 apartment units with parking spaces, and a 1,300-car public garage served by new freeway ramps and topped by landscaped malls and an office or apartment tower. A planned commercial development of the southern half of the site was not included, nor was the long-discussed creation of a park opposite the old Ferry Building (both now show fresh signs of realization). Several competitors, however, related their schemes to these areas, and to a cultural-commercial "Embarcadero City" proposed along the waterfront to the north. One entrant, protesting the program's limits, removed the ramps at the heart of the project in favor of an unbroken residential community and park (see page 115).

To help evaluate the various entries, the five-man authority appointed a seven-man architectural advisory panel of national significance to meet in San Francisco April 25-29. Members: San Francisco Architect Mario Ciampi (chairman), M.I.T. Architectural Head Lawrence Anderson, Philadelphia Architect-Planners Henry Churchill and Louis Kahn, New York Architect Morris Ketchum, Detroit Architect Minoru Yamasaki, Chicago Mortgage Banker-Developer Ferd Kramer. The city's final decision is expected late this summer or fall. Meanwhile acquisition of properties is under way, and the land, cleared under Title I, should be in the winners' hands within two years.

*and with commentary excerpted from the competitors' presentations. Proposals are shown only in outline for reasons of space, and arranged primarily for variety and interest of magazine layout.

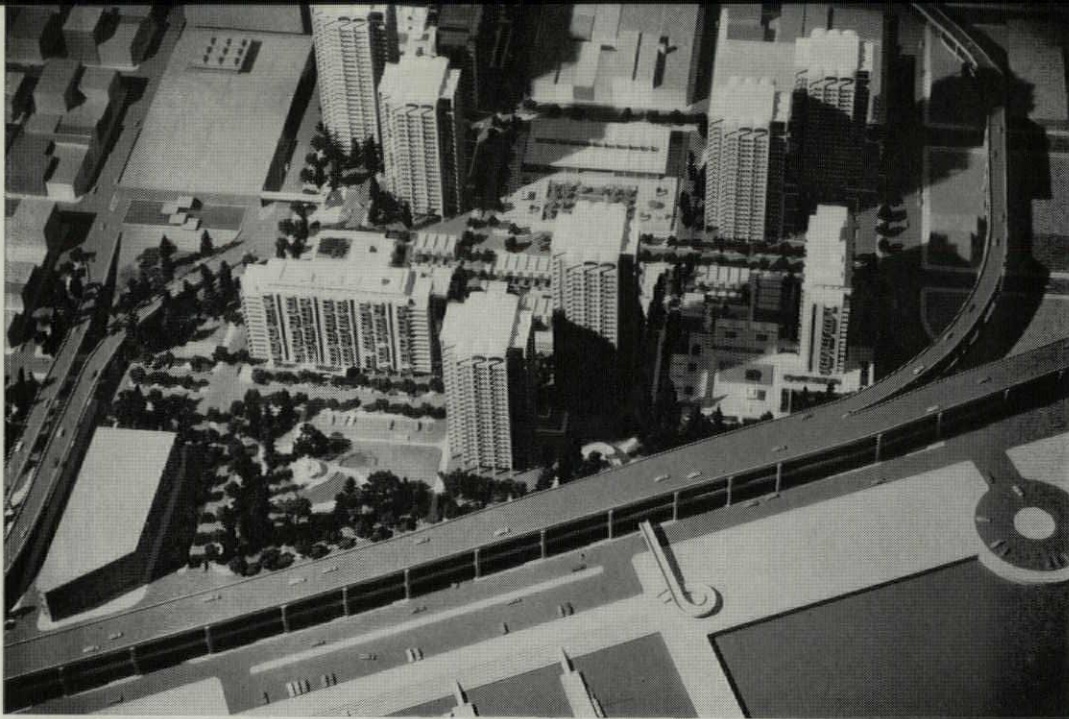

GORDON SOMMER

Drama and diversity for San Francisco urban living.

"This is a plan for urban living within the context of San Francisco. The main features are these: 1) six towers of varying heights and three long, 16-story buildings, designed to provide drama and contrast, grouped in mixed clusters of three with each cluster focused on a small square, and sited to exploit the area's excellent views; 2) a parking solution that successfully subordinates the requisite large structures to the over-all scheme: garages, closely related to the buildings they serve, kept toward exterior streets; low residential structures masking exposed garage walls, and garage roofs converted into active, landscaped terraces; 3) two- and three-story town houses and terrace apartments (with San Francisco bay windows and gardens), introduced not merely to broaden the choice of accommodations and to balance the high-rise buildings, but to weave a pervasive pattern of variety and interest at human level; 4) the fullest utilization of landscaping to shape and accent distinctive urban spaces; 5) close but subtle integration of the development into the city by siting, by adaptations of familiar building types and architectural details, and by a characteristically San Francisco mixture of high structures with low.

"While the tall buildings strike the strong design note, low buildings, artful landscaping, and a mesh of small designed spaces combine to produce the sense of liveliness, surprise, intimacy, and variety so essential to city life."

DEVELOPERS: Tishman Cahill Renewal Associates. **ARCHITECTS:** John Carl Warnecke & Associates, Gardner A. Dailey & Associates, Victor Gruen Associates.

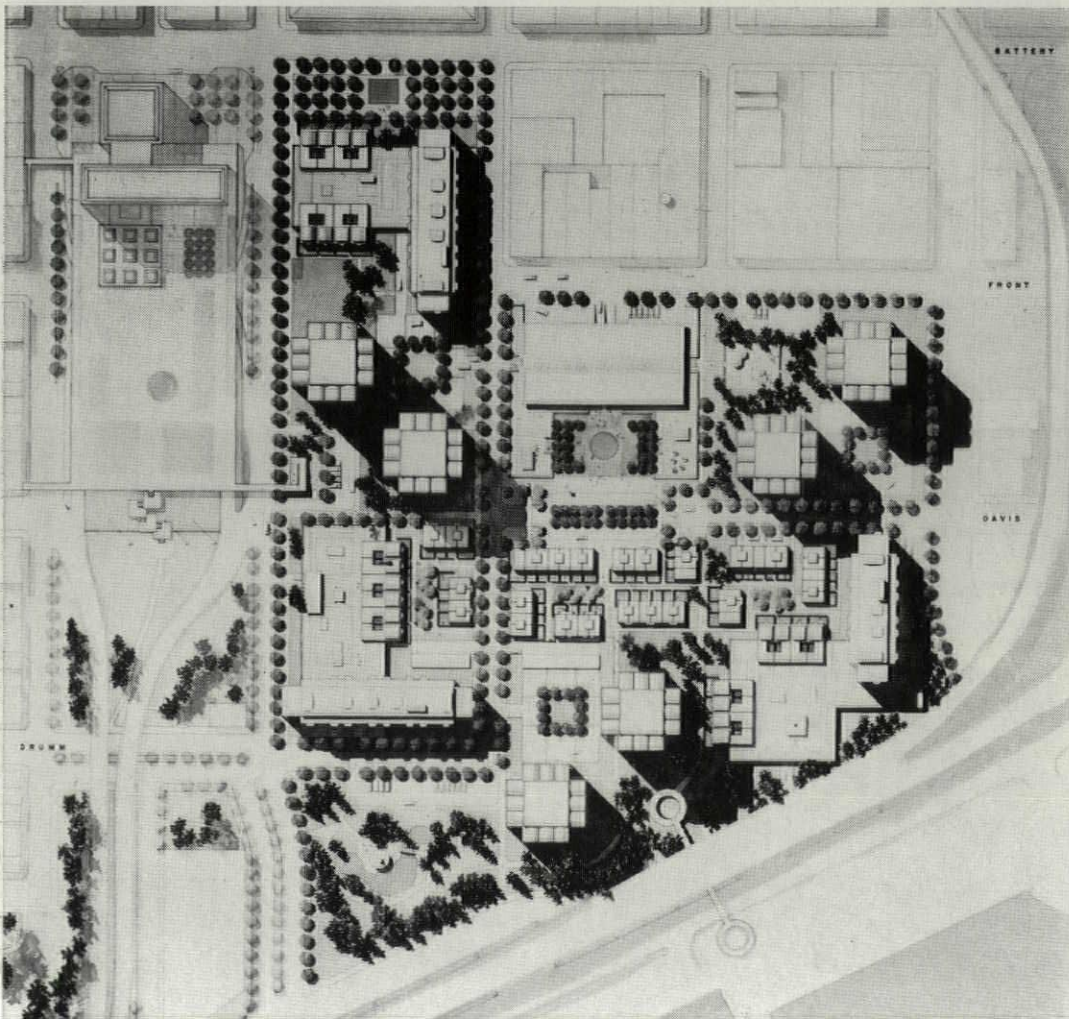
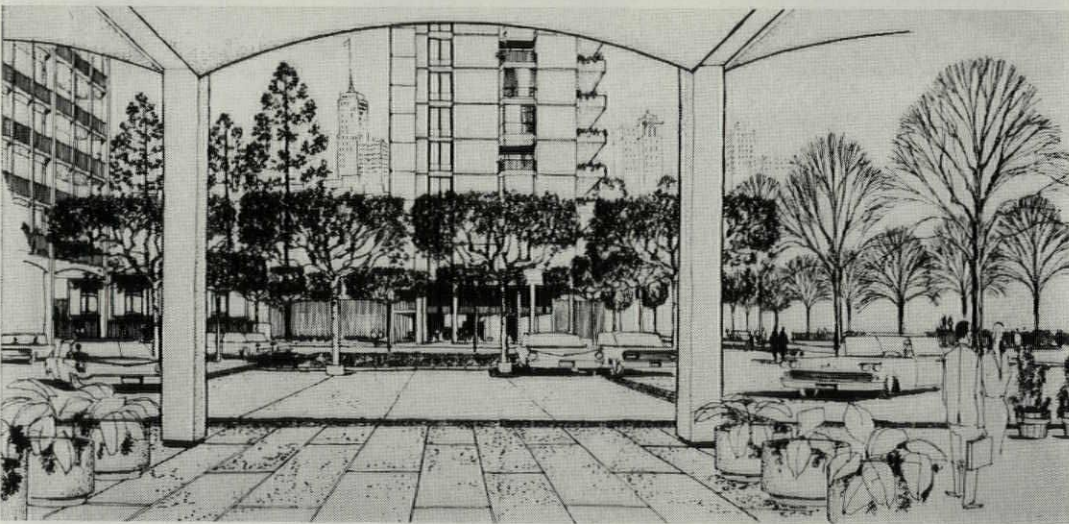

Three curved giants with balconies in the sky.

"By treating the 20-acre site in its entirety, it has been possible to achieve a composition of great strength: a broad park along the entire water front, three parking garages so designed that they become visual assets rather than liabilities, and three curving, 22-story apartment buildings with both sweeping views and complete privacy.

"The use of the three apartment buildings on the perimeter made possible a single 10-acre landscaped park, and provided spaces generous enough (736 feet between facing buildings) not only to ensure privacy for resident, but also to maintain open views of the Bay and the surrounding city. Each of the 2,575 apartments (375 more than called for) has its own garage stall. The buildings have roof gardens, 11 separate entrances, and are raised for circulation and views beneath. Each apartment has a sheltered "lanai" within the richly balconied façades, and 75 per cent have views of the Bay.

"These buildings, with their garages, are grouped in a close and strongly radiating plan around the circular court of a neighborhood shopping center in order to leave a maximum of ground free, to concentrate automobile circulation in one part of the site, and to make the most of raised plazas above the garages. In addition, there is a 500,000-square-foot office building on the central block south of the mall, in the project's commercial area. We have a letter of intent from a major insurance company indicating a desire to build just such a building on this site."

DEVELOPER: Golden Gateway Center Corp., Lewis E. Kitchen, president. ARCHITECTS: Skidmore, Owings & Merrill.

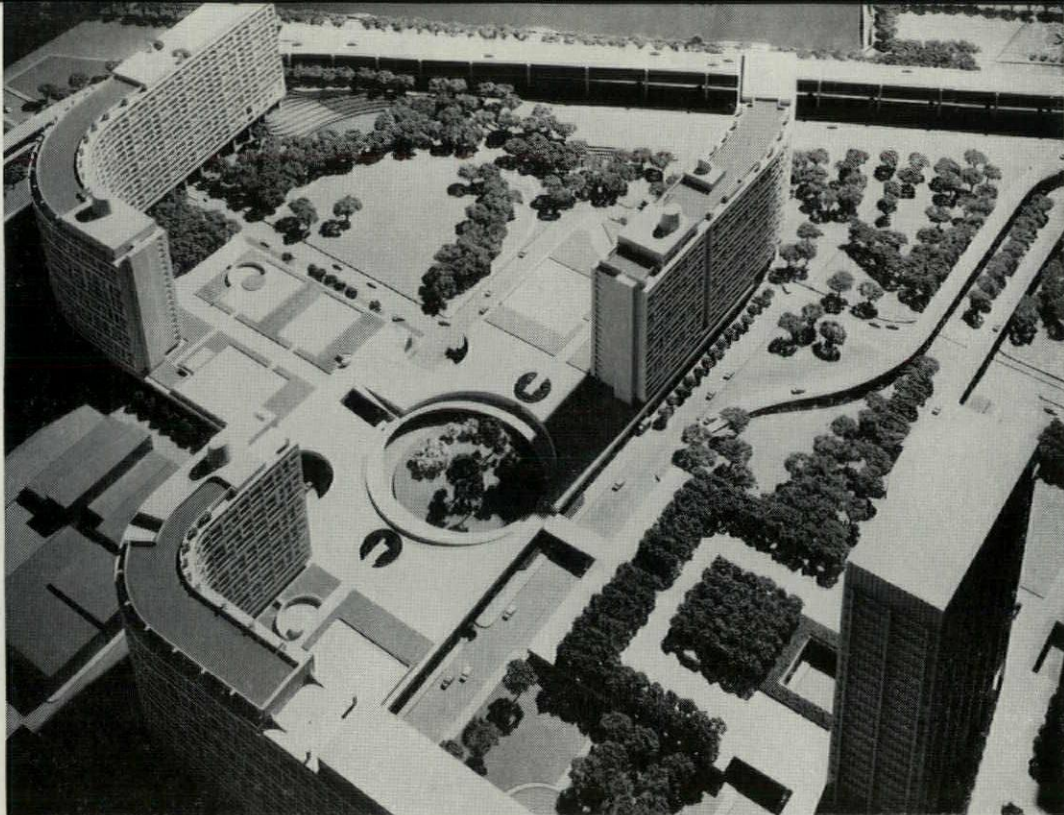

MORLEY BARR

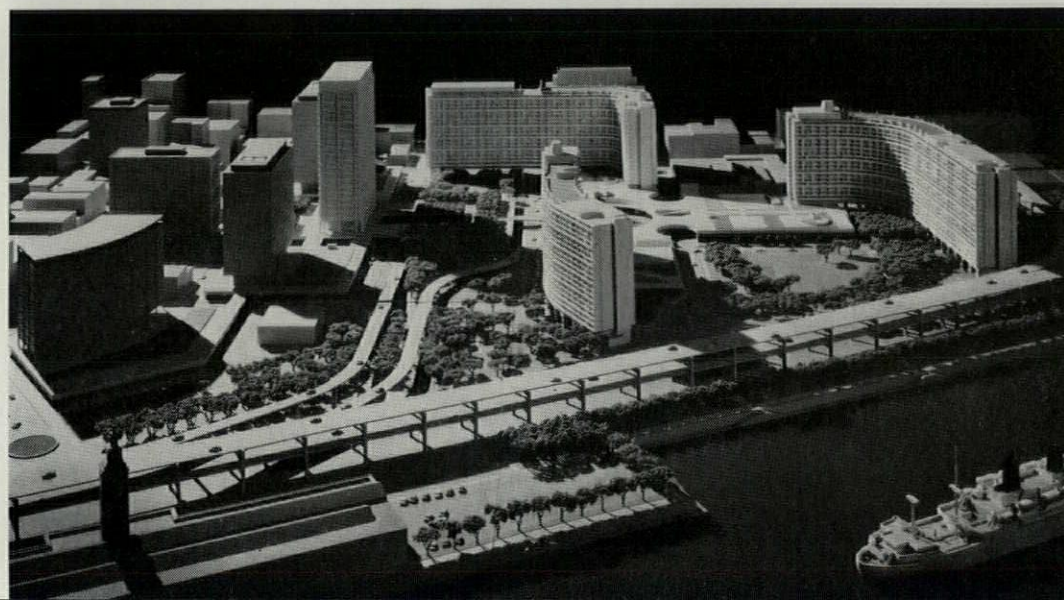
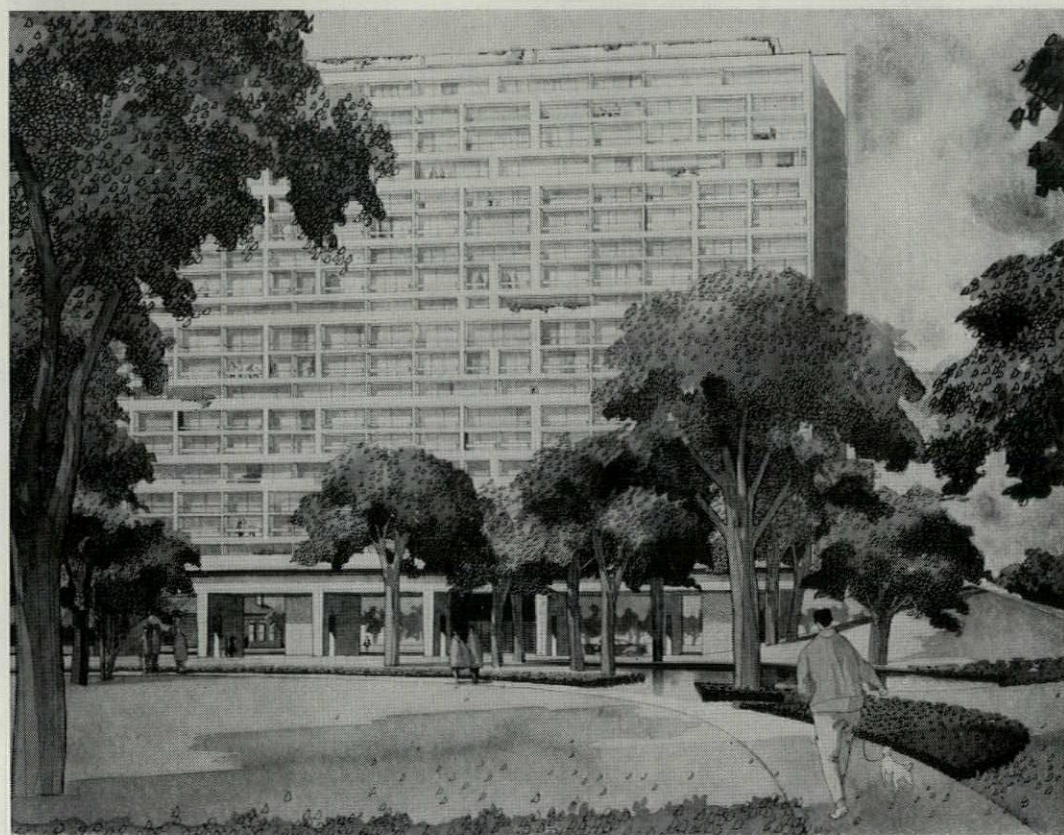

A civilized community for people—and for cars.

"San Francisco's spirit stems mainly from its intimate scale and cosmopolitan busyness—the small alley suddenly discovered, the special restaurant, the unusual shop. The concept of the approved redevelopment plan, however, is rigid. Already partly encased in the girde of the Embarcadero Freeway, for example, the area is to be still further "automobilized" by new central ramps and parking.

"We are submitting a proposal we feel is more in the spirit of San Francisco. Using Jackson Street as a 'spine,' we have tried to capture the unique charm of nearby Jackson Square with informal maisonettes and studios (400 units) and small arcaded shops and offices in buildings three to five stories high. On the north, a 20-story slab of 840 duplex apartments shields the area from existing freeway ramps; a similar slab bridging Davis Street makes a terminus toward the office district on the south. A 'town center' contains shops, post office, library, nursery school, entertainment, a community hall. There is a place for a church, a school, recreation areas, and a major civic monument or museum in a broad extension of Ferry Park. This is made possible by removing the prescribed ramps and public garage from the heart of the project. Instead, there is resident parking for 2,500 cars mainly underground, and a 2,000 car commuter garage at the back, where it can be amply served by the existing freeway ramp to the north."

DEVELOPERS: Webb & Knapp.
ARCHITECTS: I. M. Pei & Associates.
CONSULTANTS: Ernest Born, John Bolles.

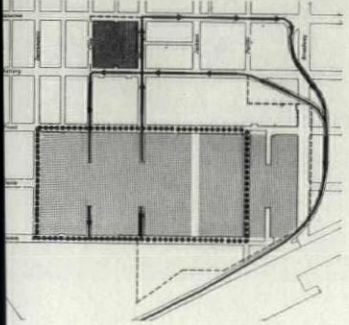
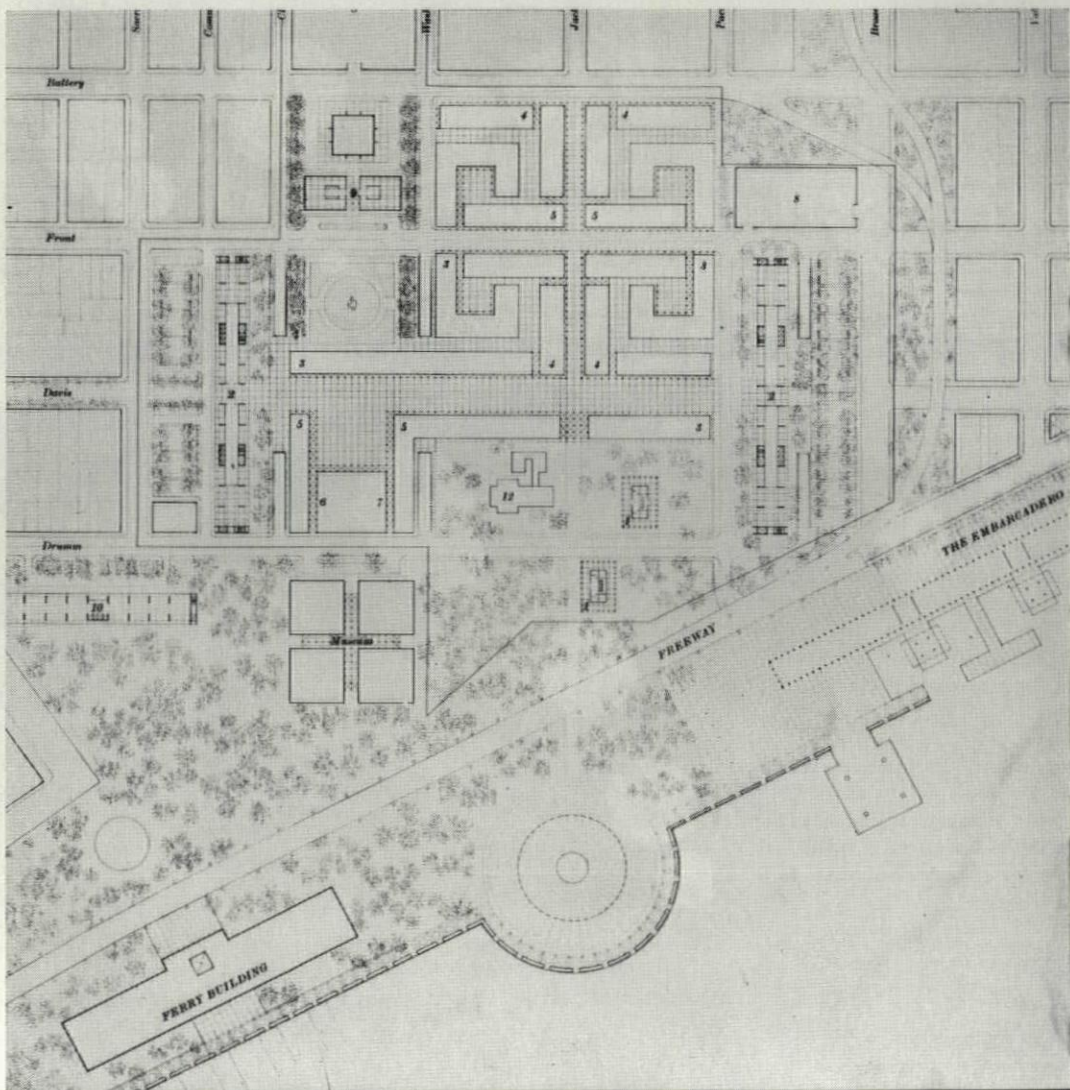

Variety and continuity, with garden offices, "maisonettes."

"San Francisco itself has set the pattern for both the concept and the details of this proposal. The slim towers that rise from the slopes of Nob and Russian hills have their counterparts in 22-story 'point' towers, which accent the flat site and gain unsurpassed views of the hills and Bay. The row house, so much a part of San Francisco, appears in two sophisticated forms atop the low parking structures: in duplex 'maisonettes' with private gardens, and in garden offices

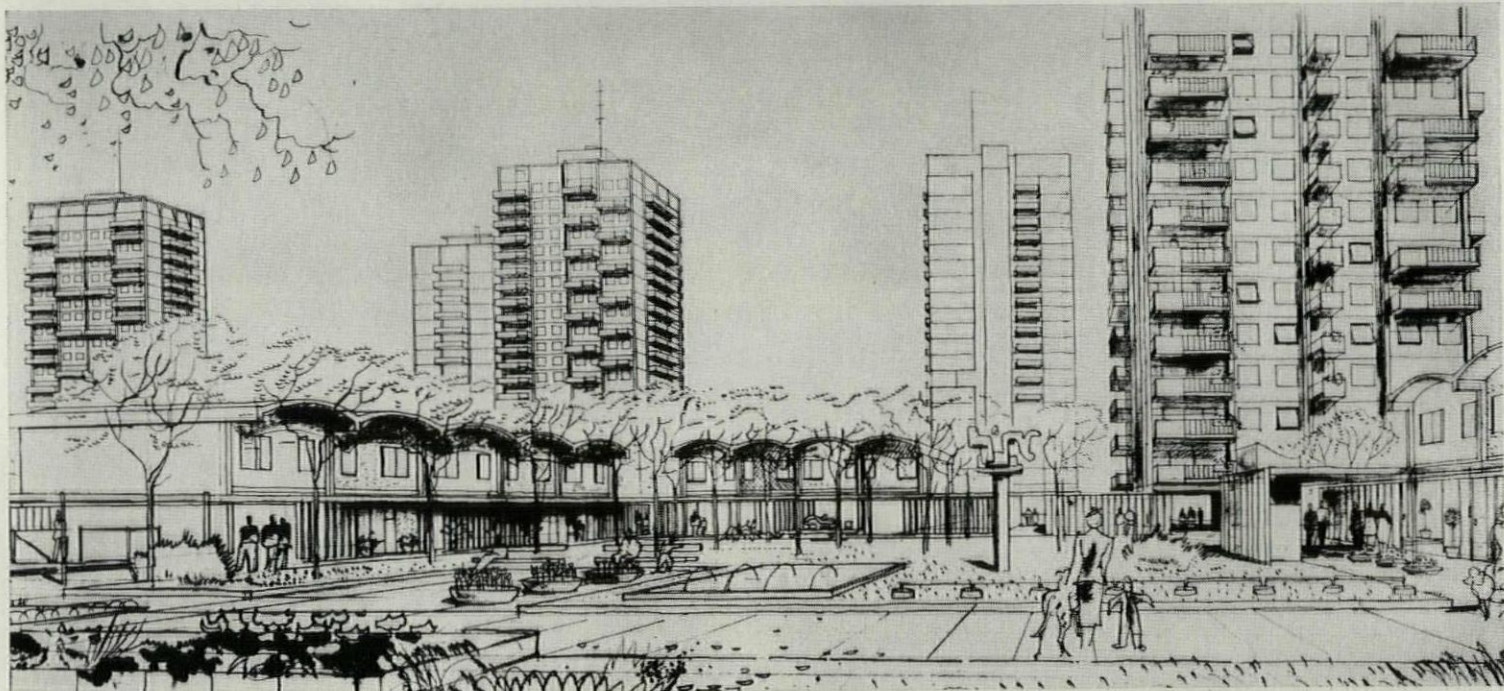
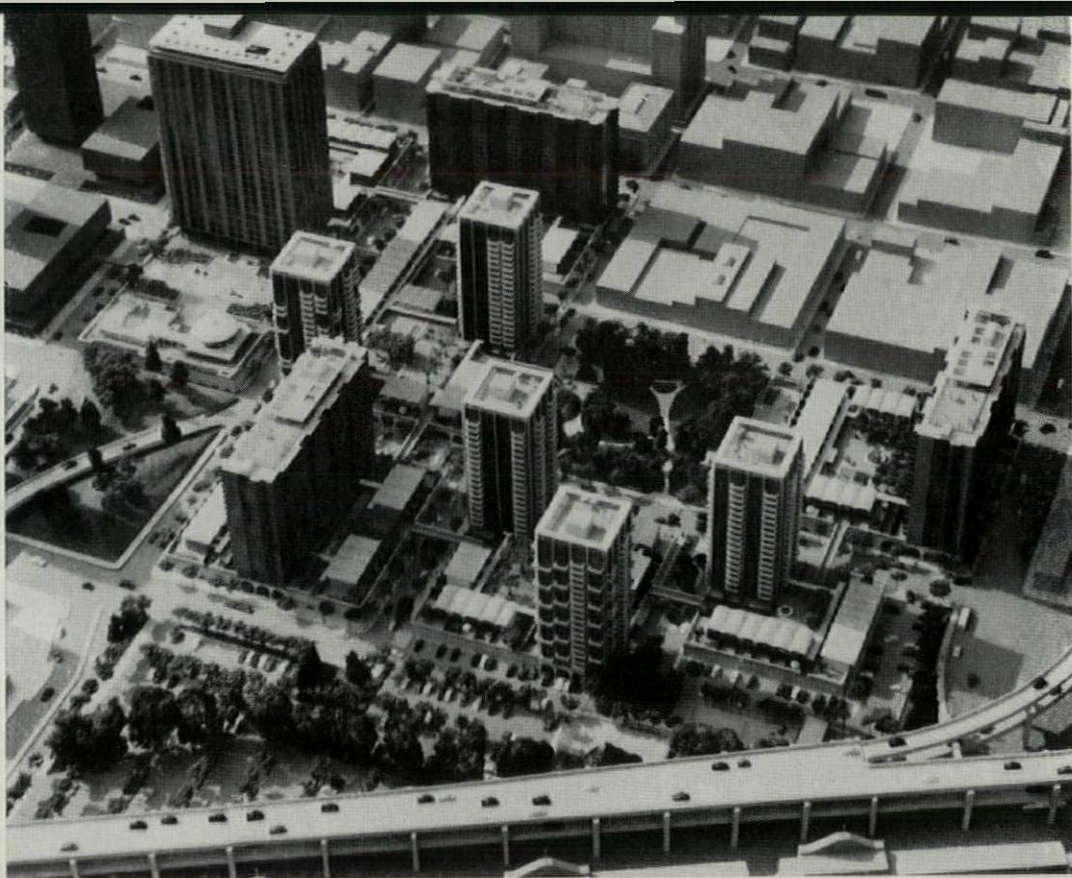

for business. These low buildings with their arched roofs introduce a smaller scale and reflect the diversity of the city's moods as much as the variety in its dwelling and office types. The formal, paved plazas; the informal, wooded park; the individual gardens—these make a many-faceted environment for buildings, but, more importantly, for people."

DEVELOPERS: Perini-San Francisco Associates. ARCHITECTS: Wurster, Bernardi & Emmons and DeMars & Reay. CONSULTING ARCHITECTS: Pietro Belluschi, Milton Schwartz.

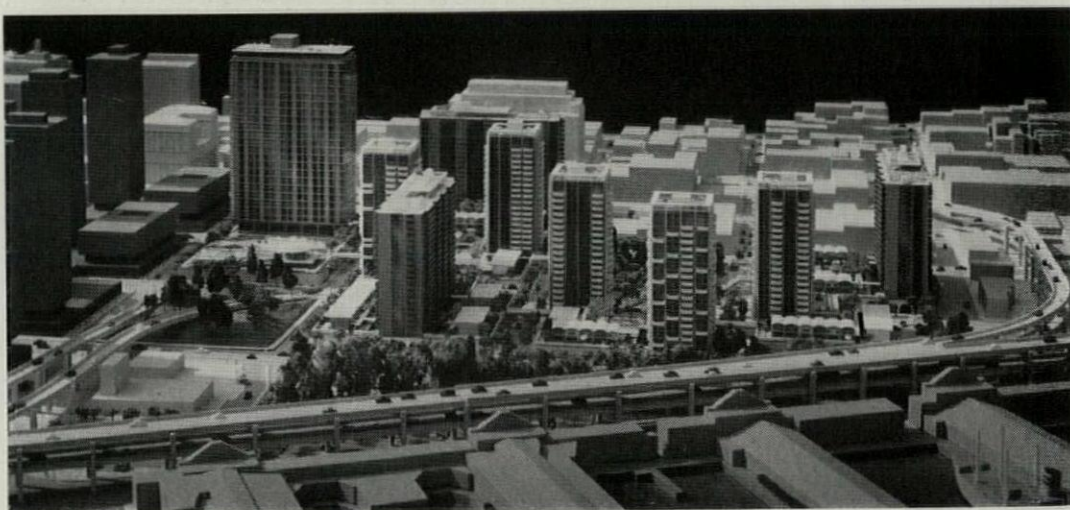

A rich play of forms in a richly faceted urban scene.

"This design demonstrates that high-rise buildings need not fall into the all-too-familiar form of stark slabs and repetitive curtain walls. These buildings have for surroundings an incomparable landscape of buildings, hills, and bay.

"Facets of characteristic San Francisco—the ubiquitous bay window, the arched window, the balcony, the serrated roof and sky line—are reflected in our exteriors. Typical building segments are repeated in a series of relationships; building heights are varied; types, sizes, and arrangements of windows, balconies, and railings are alternated to produce individual places to live, and a lively play of light, shadow, and wall planes—a group of buildings as diverse and rich in appearance as their background.

"The arrangement, with parking on two underground levels, creates spacious areas of landscaped park and assures each apartment sweeping views and individual privacy. On the north and east an earth berm 25 feet high planted with tall trees screens the gardens, pools, and walkways, both aurally and visually, from the Embarcadero and freeway. Interior arrangements have all the amenities developed over a number of years in suburban dwellings by the developer and the architects.

"The characteristic elements of modern construction—steel frame, monolithic shear wall, curtain wall, and manufactured building components—have been used here in a bold and imaginative fashion to achieve a unique solution, a design distinctly suited to and derived from the site."

DEVELOPER: Eichler Homes, Inc.
ASSOCIATE: Dinwiddie Construction Co. ARCHITECTS: Anshen & Allen.

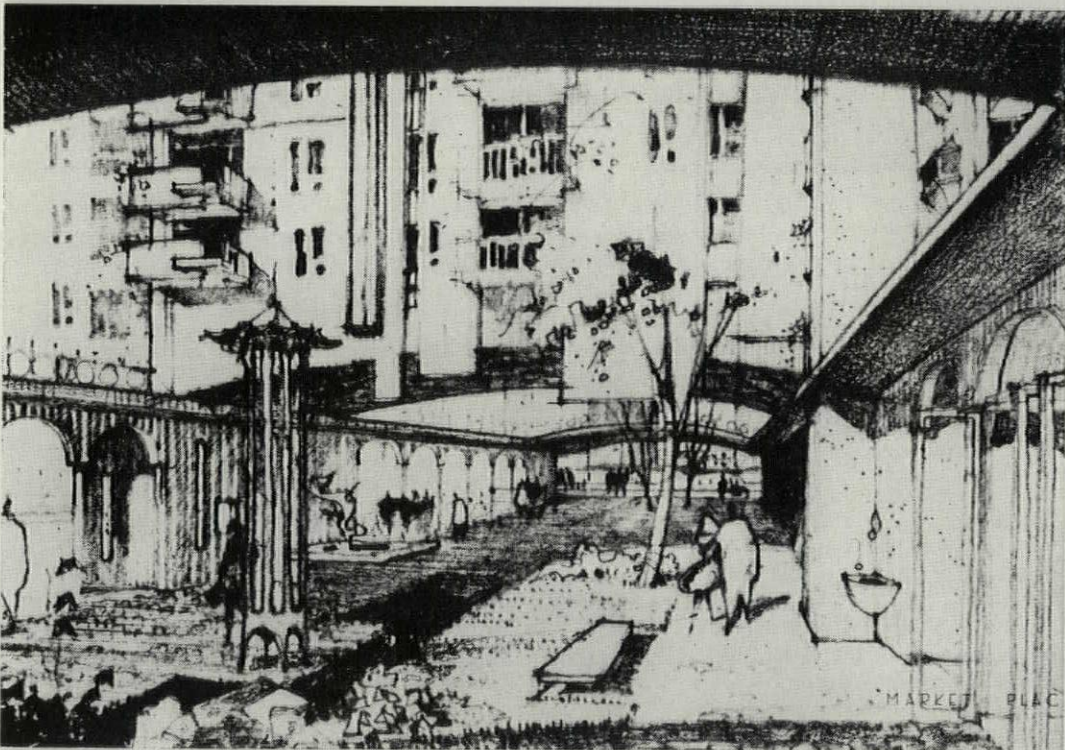
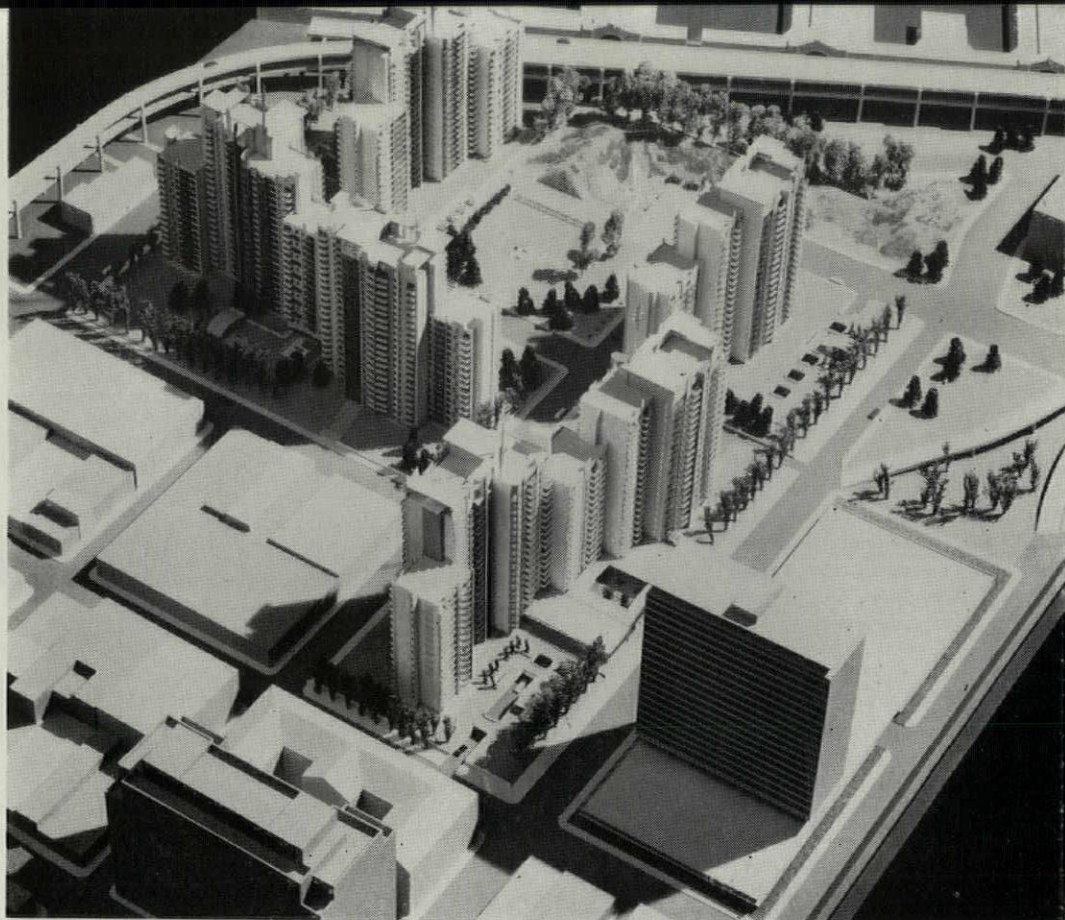

Simplicity and economy; each apartment with a balcony view.

"We have selected concrete for its rough beauty to match our hills, its rugged strength to withstand our occasional temblors. Balconies, recessed from wind, permit full windows and terrace gardens. We suggest either a 'chevron' plan of buildings, or a grouping around a parklike plaza and shopping center. We recommend 1,800 units rather than 2,200 to maintain the openness characteristic of San Francisco, and have limited height to 17 floors. To fit medium incomes, the project is designed to be simple, attractive, economical."

DEVELOPERS: Utah Construction & Mining Co. and Henry C. Beck Co. **ARCHITECTS:** Angus McSweeney, Donald Kirby, Loubet & Glynn.

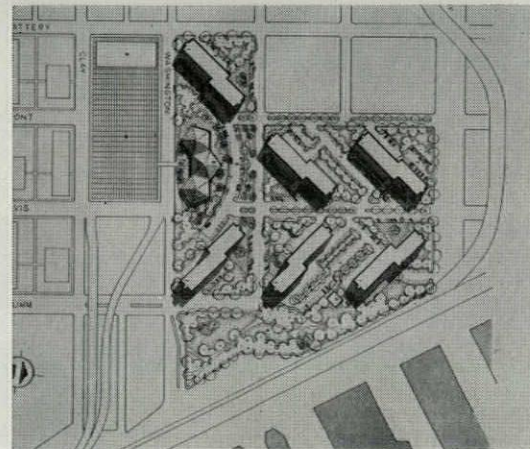
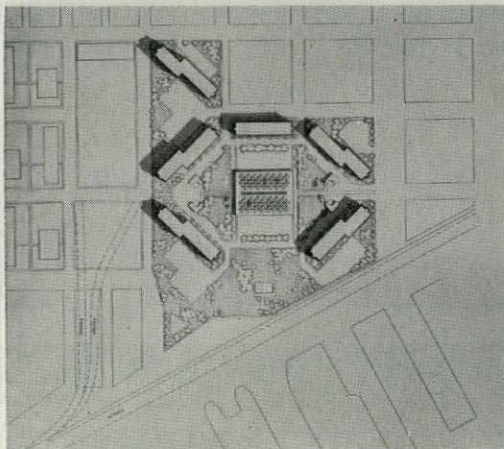

A co-op plan, and a hotel tower for older citizens.

"Our proposal provides for a cross-section of the population, including a plan for cooperative apartments. Lowest living floors are 50 feet above the street, 10 feet above freeway level. Landscaped parking decks are set back from sidewalk to elevated plazas, which are open to a central restaurant and skating rink. Above the public garage a novel plan has been developed for senior citizens in 500 to 670 hotel-style units above a cafeteria, shops, and clinics. Monthly charges for room and meals would start at \$185 under a plan worked out with FHA and the city."

DEVELOPERS: Barrett-Diversified-Lesser - Braemar. **ARCHITECTS:** Daniel, Mann, Johnson & Mendenhall and Corlett & Spackman.

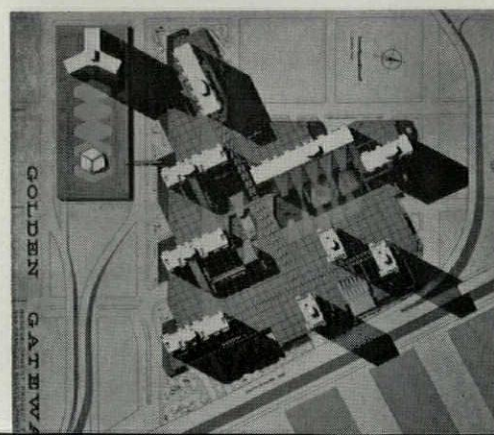
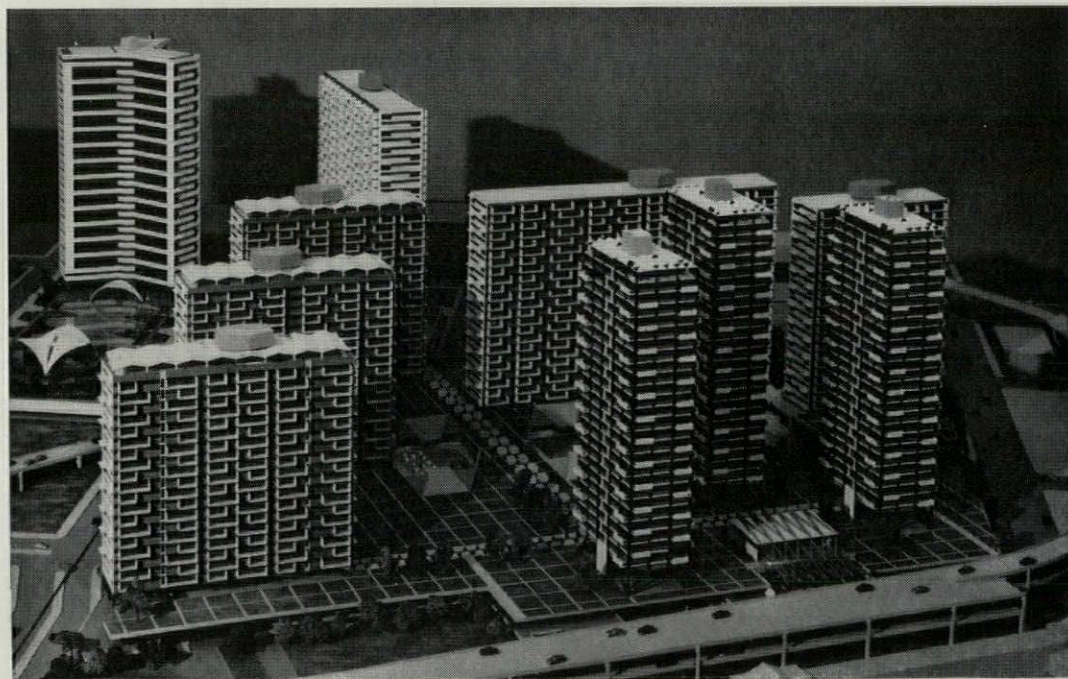

**A community
balanced for
living, culture,
and recreation.**

"This design conceives a balanced, spacious residential community in which people will enjoy the flavor, variety, and urbane atmosphere for which San Francisco is famous. An array of distinguished buildings containing about 2,200 apartments is located atop spacious elevated plazas with parking and service facilities for each apartment underneath. High-rise apartments command sweeping views of the Bay and city. These are complemented by town-house and garden apartments around quiet, intimate courts and squares which are linked together by landscaped plazas and pedestrian walks bridging the streets. Shops and stores are centrally located. Land coverage by residential buildings is less than 22 per cent of net site area.

"The developers are convinced that the cultural, spiritual, and recreational amenities which enrich daily life must be an integral part of this community. Therefore, an exhibit pavilion and sculpture garden, chapel, theater, meeting room, recreation center, indoor and outdoor play facilities are included.

"At the focal point of the ultimate development is a broad landscaped mall, to be dedicated as a public park, constructed on the roof of a public garage. Rising above the garage and mall is a monumental, 30-story office building containing 400,000 square feet of rentable space. Pedestrian bridges connect the mall to the residential section and to the office buildings south of Clay Street."

DEVELOPER: Kern County Land Co. and Del E. Webb Construction Co. ARCHITECTS: Welton Becket & Associates. CONSULTANT: Lawrence Lackey.

continued on page 221

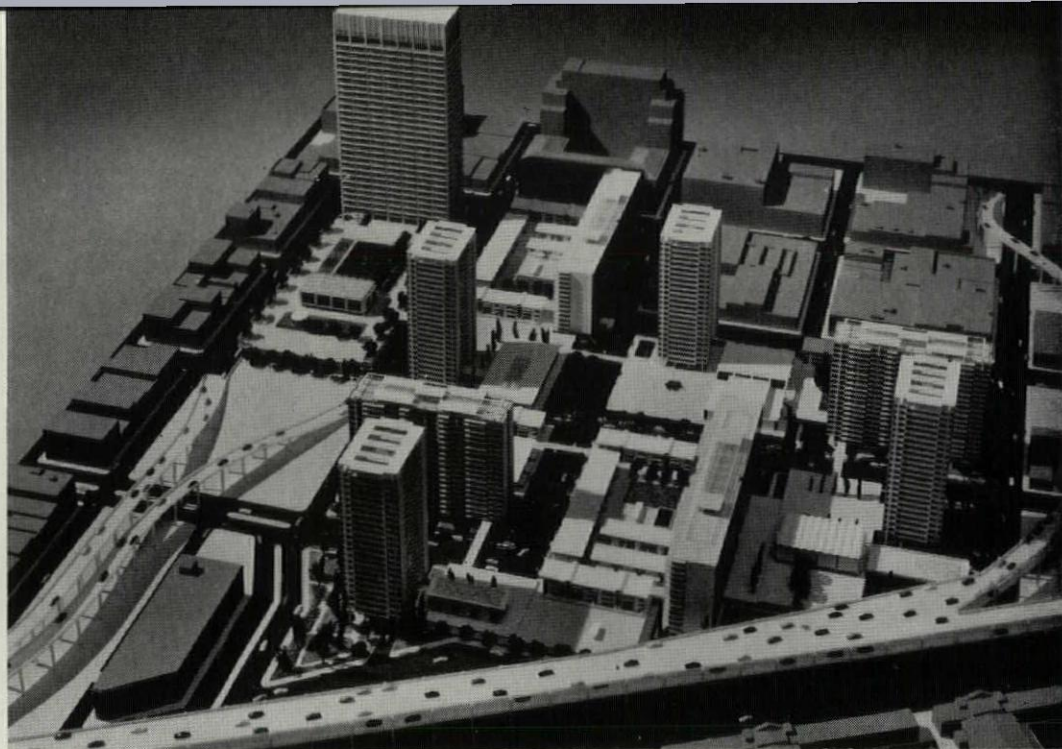

WELTON BECKET CROSS

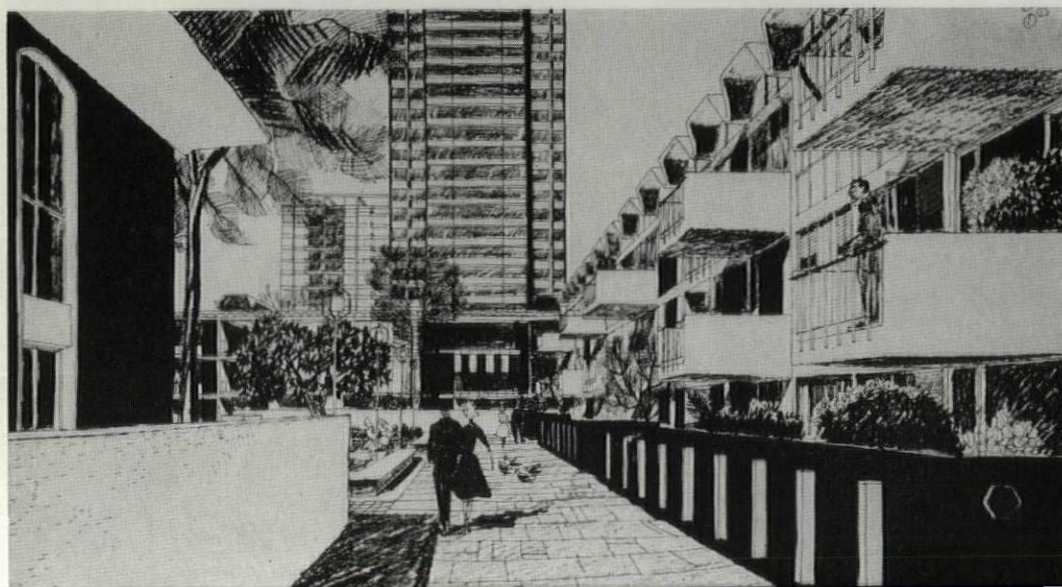
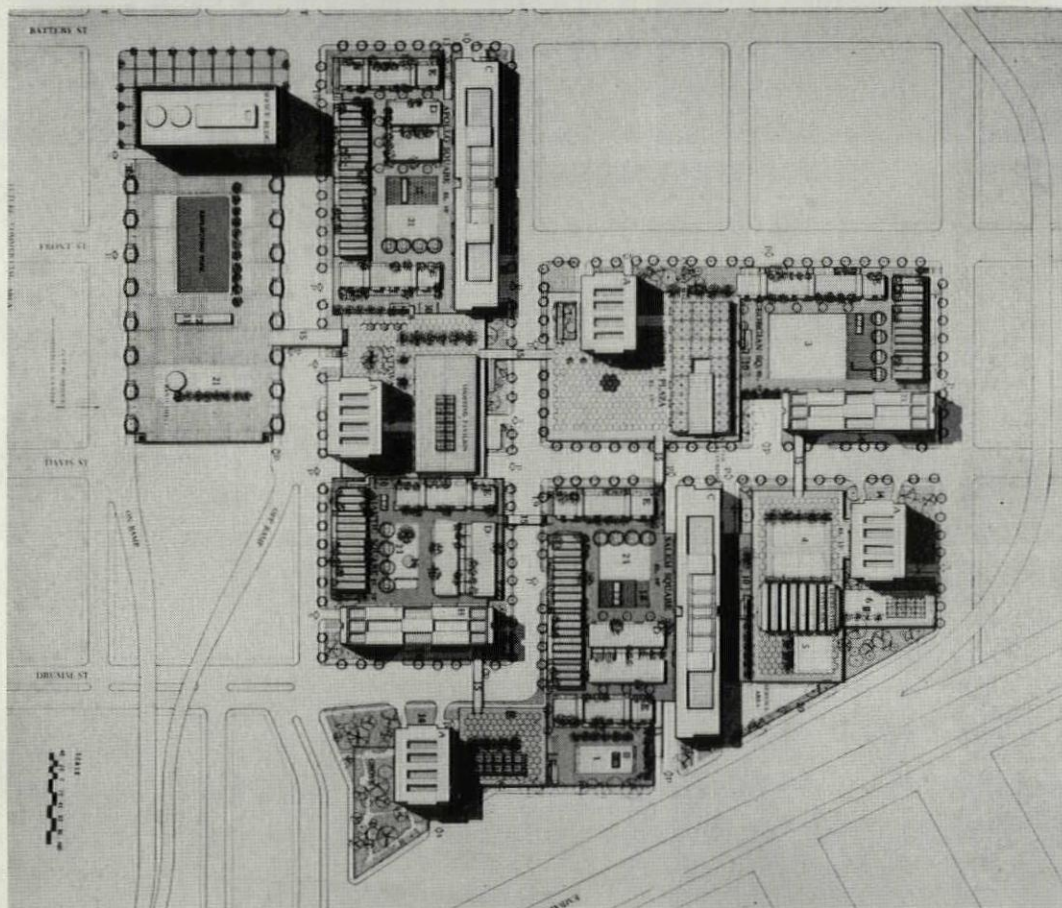

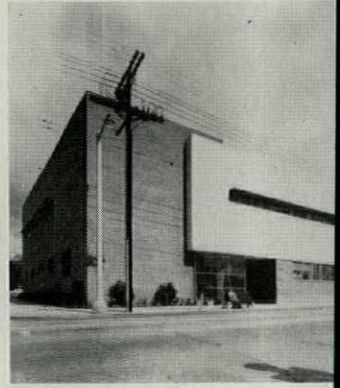
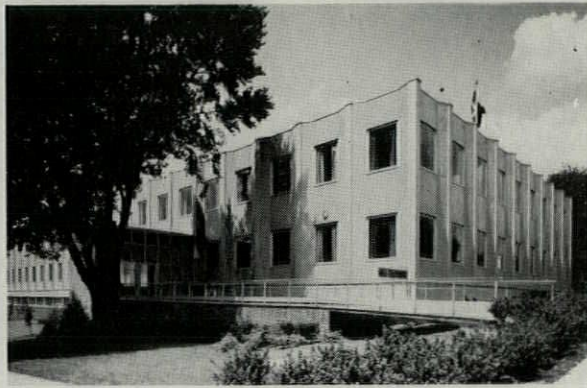
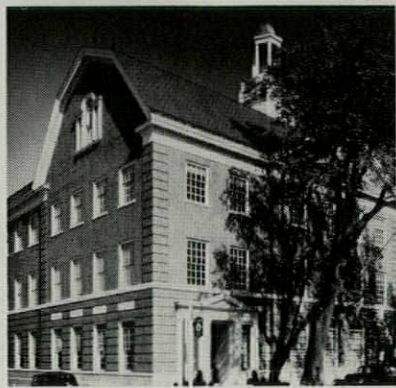
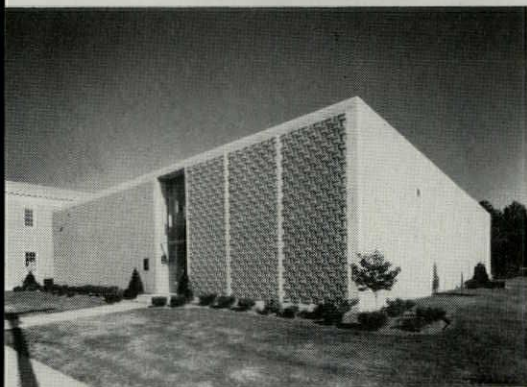
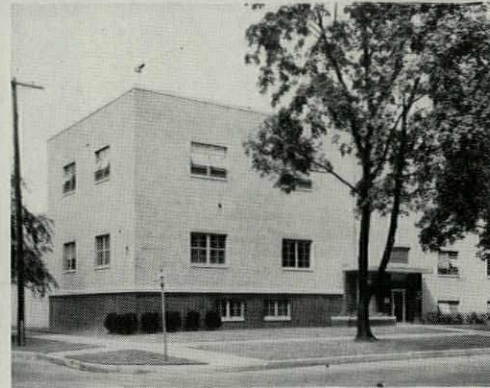
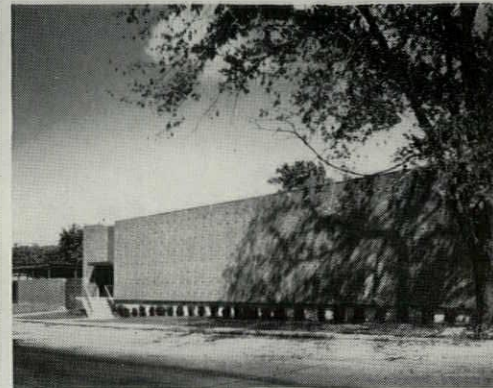

A.T. & T.'s architectural quest

BY RICHARD A. MILLER

Building's biggest client, cautiously seeking better design, has yet to ask what role architecture could really play in the wondrous telephone industry.

Up over the elevator doors at 195 Broadway, A.T.&T.'s classically piled headquarters building in downtown New York, is a parade of sculptured cherubs that symbolize the fate of art—and architecture—in the nation's biggest private enterprise. The older cherubs, carved by Paul Manship in 1916, are prancing and saucy, exuberantly stretching beyond confining bounds. The younger ones, modeled by Gaston Lachaise in 1923, are sensibly within bounds, soberly setting one foot in front of the other. Today, a perceptive sculptor would probably carve their descendants immobile. At least, that is what might have been concluded after viewing (only two floors above the cherubs) the recent architectural exhibition of A.T.&T.'s 281 "best" new telephone buildings.

The buildings exhibited, a sampling of which is pictured at the left, where actually culled from 9,860 buildings built by A.T.&T.'s 20 operating companies since the war. Impressively, the exhibited buildings were less than 2 per cent of the 15,000 buildings in the Bell System; and this sheer, incomprehensible volume makes it tough for A.T.&T. to obtain anything as elusive as good architecture. In 1959 alone, the Bell System constructed 1,344 buildings and put additions on 528 more, at a total cost of more than \$175 million.

In both 1957 and 1958, A.T.&T.'s construction pace was enough to put it way out ahead on the list of building's 100 biggest clients (FORUM, Oct. '59). If the building activities of A.T.&T.'s subsidiary Western Electric Co., the second biggest client in 1958, are added in, A.T.&T. and related com-

panies spent more than \$225 million on building last year—more than 9 per cent of their total capital outlays.

Merely to spend sums of that order year after year takes complex organization; but to spend them in carefully planned support of the fantastic expansion of the telephone in the U.S. (up from 111 million daily conversations at war's end to 265 million in 1959), takes an organization of enormous scope.

Most of A.T.&T.'s building operations, and its other operating functions, are conducted by 20 associated operating companies which blanket the U.S. Each of the companies, under an independent president, plans future building and equipment needs at least ten years ahead through the office of a chief engineer. For the actual building operation, the chief engineer depends on a building engineer, the head of a sizable organization in each company.

A.T.&T. itself, which is the representative, in fact, of over 1.7 million shareholders who "own" the operating companies, was initially formed to operate so-called long lines. Today, for a fee of 1 per cent of the operating companies' local and long-distance revenues, the "American Company" additionally provides important engineering, commercial, and financial services to the "Associated Companies."

Also operating under the American Company are the Bell Telephone Laboratories, a centralized research facility, and Western Electric Co., which makes, buys, distributes, and installs telephone equipment.

It is not surprising that this amalgam gives a rather mixed impression of itself in terms of its building opera-

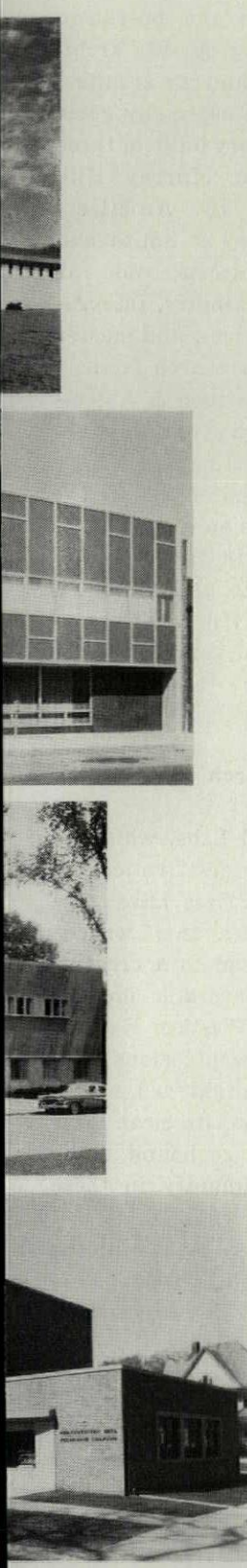

A.T.&T.'s postwar buildings, including such oddly termed structures as No. 5 crossbar buildings and long-lines toll structures, were recently reviewed by chief engineers in the 20 Bell System operating companies. The buildings shown here, ranging from Flandreau, S. Dak. to Lewiston, Me., each one by a different architectural firm (see list, page 228), are among the 281 architectural best commensurate with economy. They were submitted to a two-day jury meeting held at 195 Broadway, A.T.&T.'s corporate headquarters in New York. Of the 20 buildings shown, which ones received awards?

The answer: honor awards are shown in the top row. The next two rows received merit awards.

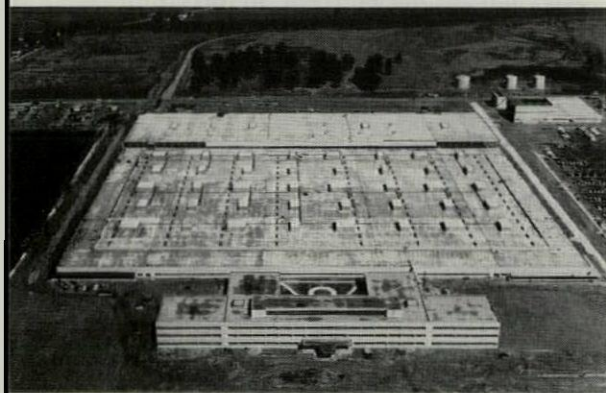

Western Electric Co., A.T.&T.'s manufacturing and distributing subsidiary, was, in 1953, the second biggest U.S. building client all by itself. Its New York general office (sketch above), under construction across from A.T.&T.'s 195 Broadway, is the current largest project, but a series of manufacturing plants like the recently completed 1.6-million-square-foot Columbus, Ohio plant (photo above) has kept the entire postwar program clipping.

Bell Labs, A.T.&T.'s research operation, is currently housed mainly in the sprawling Murray Hill, N.J., buildings (photo right), built in three stages since 1940 to a master plan determined by Architects Voorhees, Walker, Foley & Smith. Bell Lab scientists will soon branch out into a loft-plan building (model photo, right), to be built in Holmdel, N.J., designed by Architects Eero Saarinen & Associates.

tion. In contrast to A.T.&T.'s commitment to outside architects and engineers, Western Electric, for example, like many another production enterprise, generally designs and engineers its own buildings. Except for the new home office (drawing left) across the street from 195 Broadway, Western Electric buildings are of two types: distributing centers, of which there are 32 (one, at least, in the territory of each operating company), and manufacturing plants, of which there are currently 22. Like parent A.T.&T., Western Electric plans for building needs ten years ahead of time but, also like A.T.&T., it conscientiously avoids building to fill all its needs. Instead, it keeps a "cushion" of rented space to allow for business fluctuation.

After World War II Western Electric found itself both too concentrated and too scattered for its own good. The 14-building, multistory Hawthorne plant in Chicago, for example, with nearly 4.5 million square feet, was far too big by today's standards, yet countless other plants, largely acquired to fill defense needs, spread manufacturing operations out too far. The company's answer was to build a series of six one-story plants ranging in size to 1.8 million square feet. The latest, at Columbus, Ohio (photo left), is typical. At the same time, a policy of moving its highly mechanized distributing facilities out of rented space helped multiply Western Electric's investment in building six times since V-J Day.

Bell Labs, the other major A.T.&T.

subsidiary, works like the operating companies in employing outside architects and contractors—and the architectural results have been especially good. The pioneering laboratory built in three sections since 1940 at Murray Hill, N.J. (photo below), by Architects Voorhees, Walker, Foley & Smith and Western Electric architects, was far ahead of its time in flexibility, integration of mechanical services, and master planning. Now, a new research facility, by Architects Eero Saarinen & Associates, is being planned (model photo below) for Holmdel, N.J.

Bell Labs, like the rest of A.T.&T., is sensitive to the impression its buildings make. Saarinen may, in fact, owe his commission in part to the mistaken identity of the Murray Hill buildings in a recent U.S. geological survey. On the new maps the labs were called a veterans' hospital!

Twenty clients in search of an image

In the hands of Bell Labs, which is, after all, outstandingly creative technologically (two Nobel Prizes have gone to Bell Lab scientists), this concern for impressions can lead to a creative notion of how an unfavorable impression can be changed. Western Electric has little trouble with impressions: like the plants of most enlightened manufacturing organizations, its clean, spaciouly set buildings are bound to be welcomed by any community in these days of industry-seeking.

Even with the best wills in the

continued on page 218

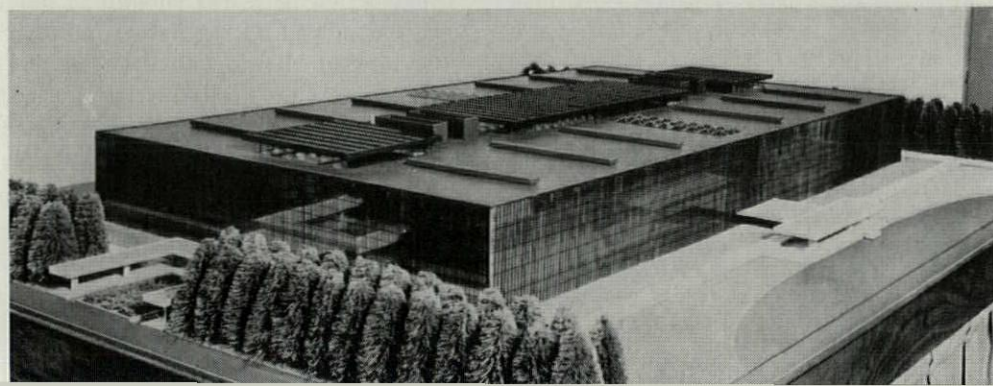

The Client & the Architect

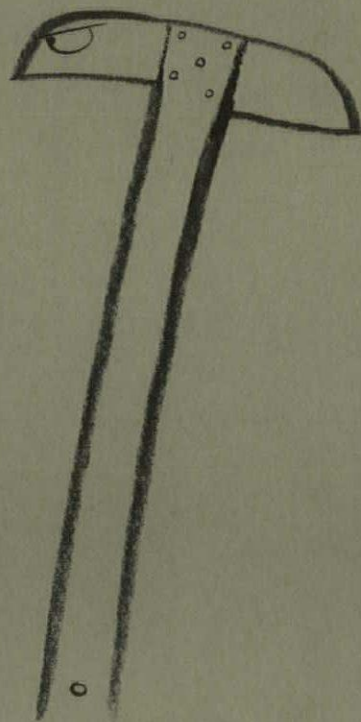

First meeting

Osborn



Exposition

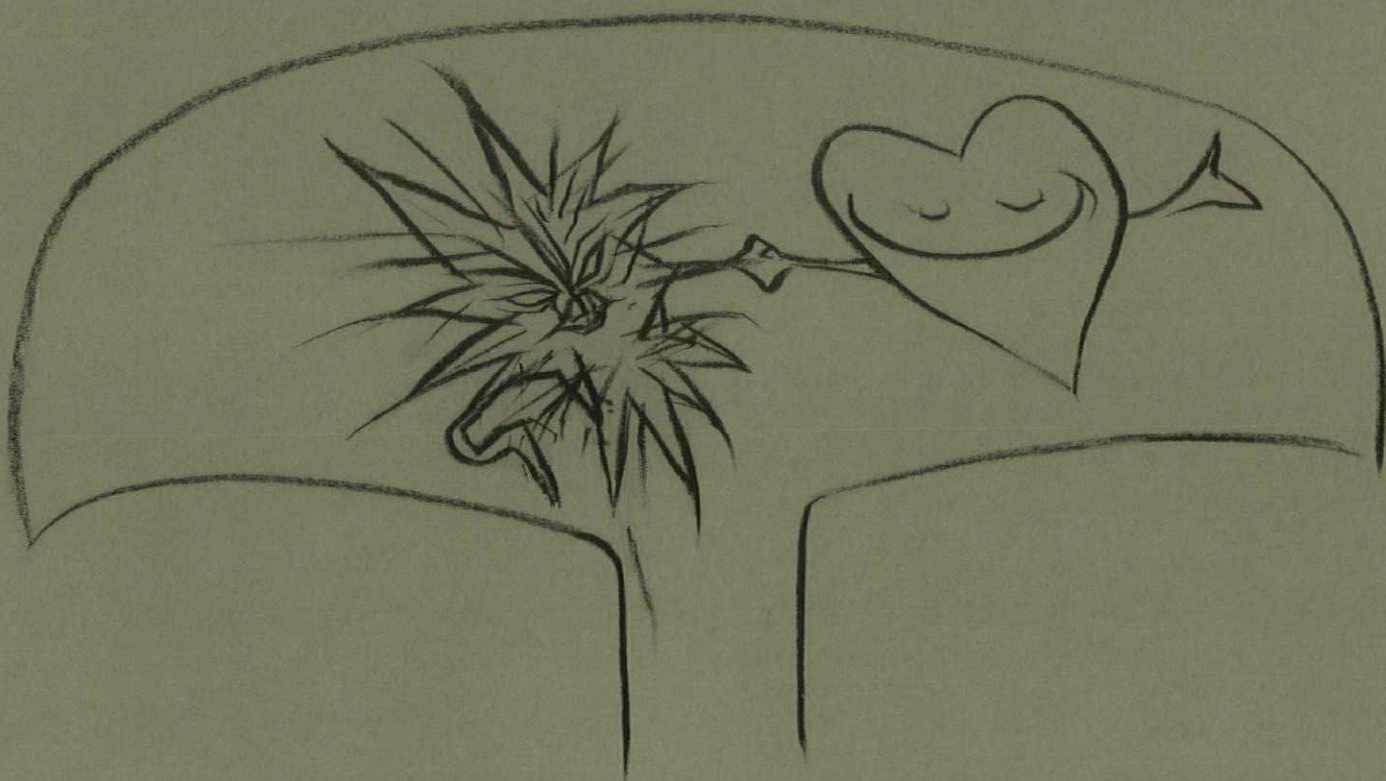

Creation of the idea



Honeymoon



Disenchantment



Deterioration



Horrid snarl



Freeze

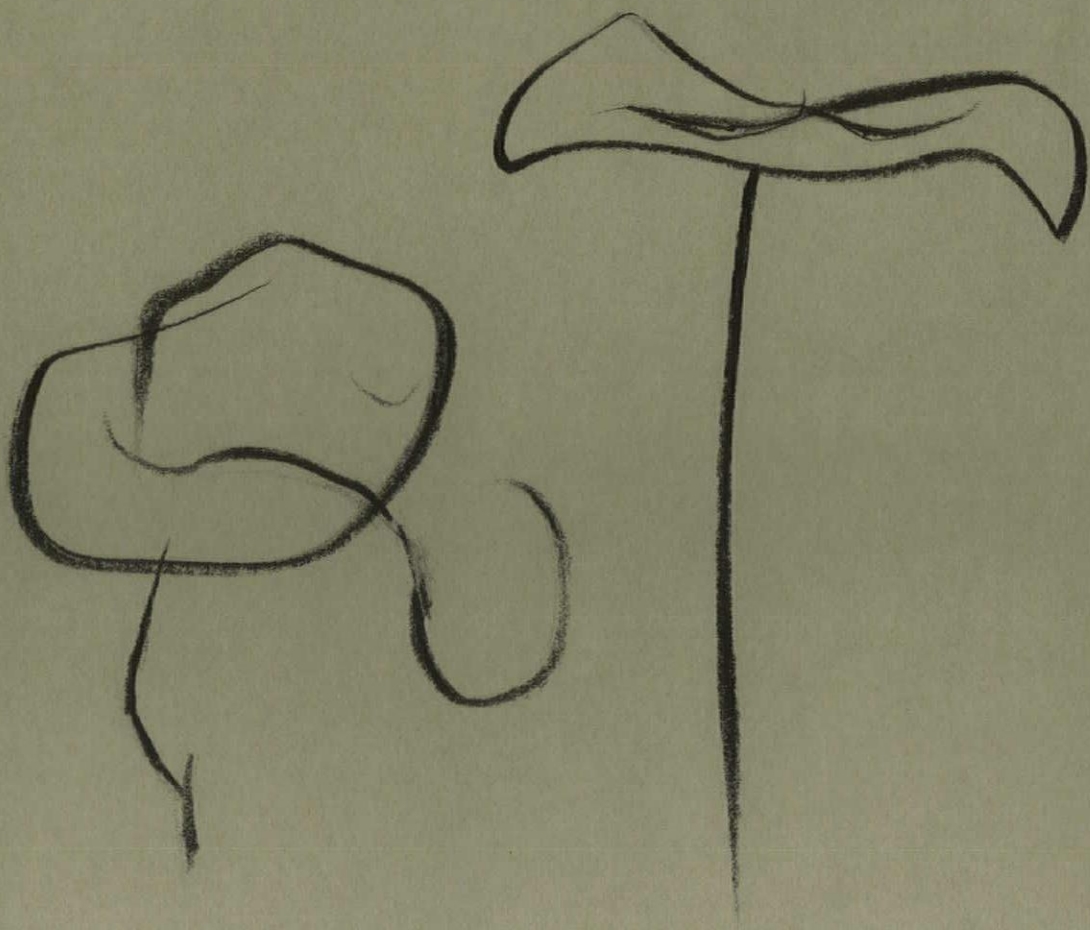

Thaw

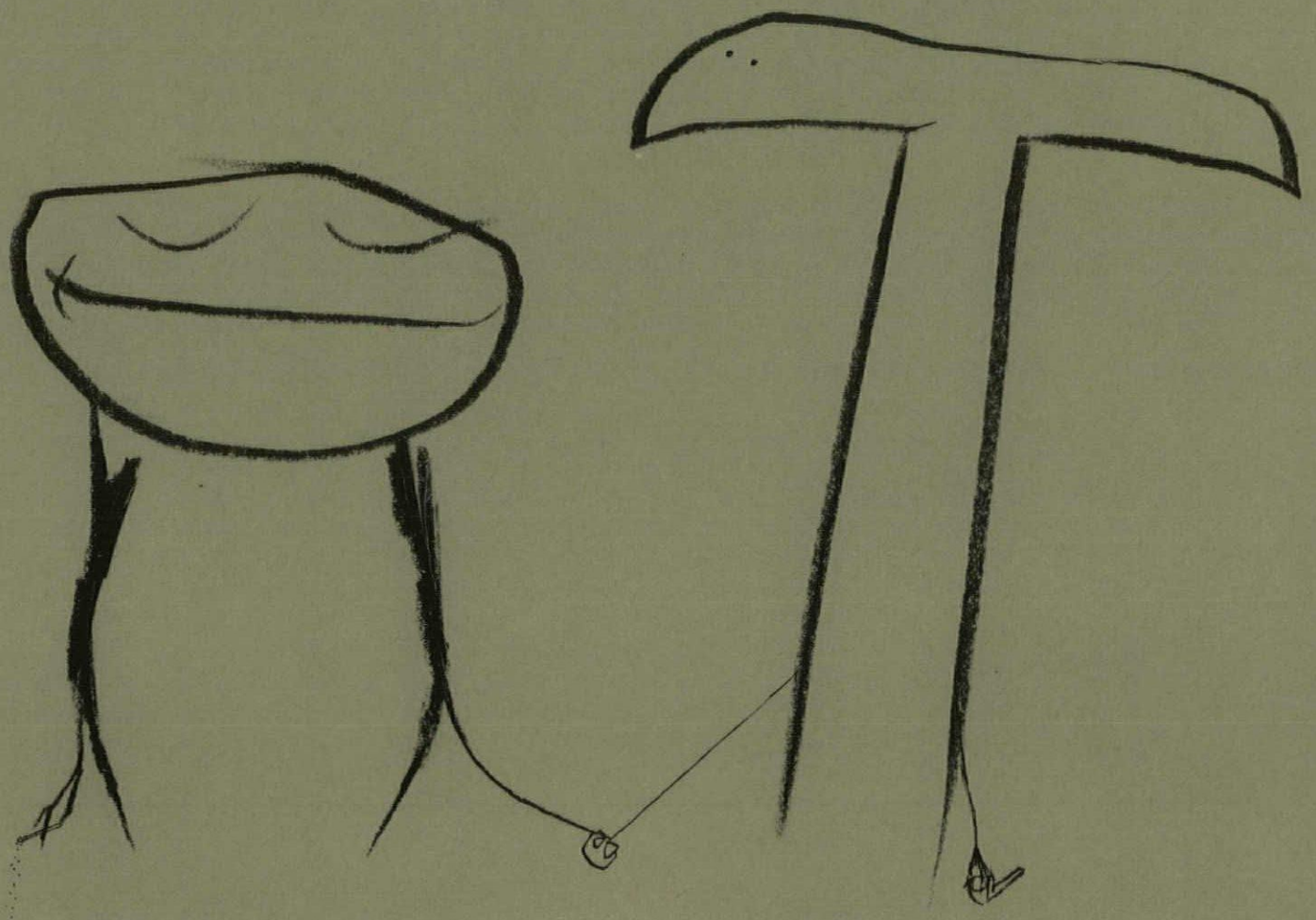

Tenuous reconciliation

What next in shopping centers?

BY DAVID CARLSON

The economics have been changing—stress now is on long-term, steady gains rather than quick, speculative profits.

From 1946 to 1960 the most pervasive new building type on the U.S. scene was the shopping center. It came in all sizes, shapes, and colors, sprawling across the land as indiscriminately as the FHA towns it invariably followed, or squatting strategically beside some superhighway linking a city with its suburb. Through the early years of this period the shopping center was, more often than not, simply a real estate speculation, whether as part of a residential tract development or as a one-shot effort by a shrewd developer to "get in on the ground floor" in a fast-growing area. The economics—and merchandising—were pretty crude, as were designs. Land was cheap, building costs not yet overburdensome, and, as a consequence, there were handsome capital gains made on the first shopping centers. As in most speculation, development was frequently haphazard, with only a few rules of thumb as guides, and no one was ever certain just how profitable the new centers would be.

Today, the development of shopping centers is, for the first time, showing the characteristics of a mature industry. Its maturity shows up in many ways. First of all, the business has already suffered through a minor recession, when shopping-center development slowed drastically in 1956-57 (FORUM, Aug. '57). And it has proved its resiliency by bouncing back, in the last two years, to hit new highs for total square footage of shopping-center space. This year will be the best ever; an estimated 900 new centers—about 850 of them small—are expected to be finished, adding a total building area of about 70 million square feet to the nation's retailing space. By the end of this year, there will be standing more

than 4,500 shopping centers of all sizes, about 4,200 of them of the small, neighborhood type (averaging about 60,000 square feet of total building area).

Maturity in shopping-center development has resulted from factors other than a brief skirmish with the business cycle, however. The mere fact that shopping centers are today seldom inspired by real estate speculation is another key symptom of maturity. Several factors have caused this, but paramount has been the rise in the cost of available land. Prime suburban sites which could be bought for \$200 to \$2,000 per acre a decade ago today command prices of \$10,000 to as high as \$40,000 per acre. Also, the estimated "average" costs of building new shopping-center space has risen in the past decade from \$5 to \$7 per square foot to \$11 to \$14 per square foot. And some centers have recently cost as much as \$35 per square foot to build.

These elements have removed much of the potential for large—and fast—gains (see page 237). The shopping-center developer, rather than being a freewheeling real estate speculator, is increasingly more like the conservative merchant he has as tenants. This stems largely from the phenomenon of the percentage lease, by which the tenant pays a percentage of his gross sales as rent and which forces on the developer a sympathy with the economic well-being of the merchant. As Developer Leonard Farber, who is also president of the International Council of Shopping Centers, says: "The developer has a vital interest in each merchant's experience and ability as well as in methods by which he, as landlord, can help build sales volume."

Thus, as long-term investment potential crowds out short-term speculation as a motive for development, shopping-center backers are taking a longer view of their economics. The pressures of the merchants and lenders themselves are reinforcing this view, which is basically conservative and sunk in

a bedrock of actuarial methodology. Today, the development of shopping centers is much more in the nature of a merchandising venture than a real estate speculation.

Boom at the bottom

Few experts will yet concede that this maturity, based as it is on conservative and well-regulated economic dicta, must necessarily spell an end to the shopping-center boom. Yet most believe that the nature of the future pattern of development will be different from that of the past decade or so.

The building of the vast regional shopping centers—those with from 500,000 to over 1 million square feet of building area—already shows definite signs of slowing down. From 1948 to 1960, about 70 of these centers were built. In the next 15 years, only about 60 more are likely to be built, most of them in the latter part of that period. A number of lenders—and developers—are of the opinion that there is no more room on the fringes of many cities (e.g., Milwaukee, Detroit, Chicago, Los Angeles) for large regional centers, although there are still plenty of opportunities for smaller neighborhood centers, containing no more than 100,000 square feet (and frequently around half that space).

One expert, Bruce Hayden, secretary of the mortgage and real estate department of Connecticut General Life Insurance Co., is more worried about the future of the so-called intermediate, or community, centers, which average about 250,000 square feet of building area. Hayden says: "The industry is suffering from considerable overproduction, particularly in the intermediate-size center." He cites one Texas city which has five community-sized centers within a 3-mile radius, and a huge regional center scheduled smack in the middle of the area. Hayden says: "The intermediate-sized center is highly vulnerable to future competition from a regional center and is too small to forestall competition even from other centers its own size."

Future building will be concentrated in the small neighborhood centers, al-

though these are always overshadowed by the bigger, more glamorous regional and community variety. Experts are predicting that 8,000 small centers, mostly of the strip type, will be built in the next 15 years, encompassing 420 million square feet of retail space. This in itself is more than the total of all postwar shopping-center construction, and twice the total of neighborhood center construction. Key tenants in these small centers are usually supermarkets and drugstores, and the centers are less costly to build (on a dollars-per-square-foot basis) and easier to finance.

Neighborhood centers have little of the impact, visually or economically, on an area that the larger centers have, and it is the regional and community centers that most experts have in mind when they simply say "shopping centers." In the development of these larger shopping centers, the signs of maturity are even more persuasive than in the small ones. Most important is the clear indication that the development of large centers has become increasingly dominated by two major influences—the big lenders and the big retailers.

The big lenders

The trend of dominance by big lenders and big retailers really started the day the first shopping center was conceived. This is not to subscribe to the theory that bigness is an inevitable concomitant of growth in a capitalist system, but rather to indicate the key role these two groups have played since the beginning. And in the past three years, their rise to a position of dominance has accelerated, and has resulted in their being today the pivotal elements in the development of any shopping center of over 250,000 square feet, and many smaller ones.

No single factor has figured more prominently in this rise to dominance of the big lenders than the tight mortgage-money market, which has prevailed with only short breaks for most of the past three years. Bruce Hayden observes: "Centers that would have been readily financible a few years ago



Regional centers (average building area: 800,000 square feet), like the mammoth Eastland Center near Detroit, are the biggest, most glamorous of all. Since 1948 there have been 70 of these huge centers built throughout the U.S., and an additional 60 are expected to be built in the next 15 years.



Community centers (average building area: 250,000 to 300,000 square feet), like the new, completely enclosed Charlottetown Mall in Charlotte, N.C., will probably show a slight decline in building activity. Since 1948, about 250 centers of this size were built, but only 200 are predicted for the next 15 years.

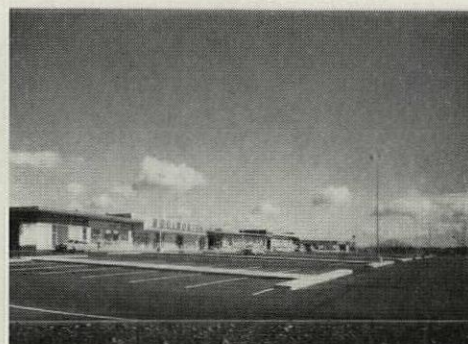

Neighborhood centers (average building area: 60,000 square feet), like this one near Greenwich, Conn., make up more than 90 per cent of all the 4,500 centers that will have been built by the end of this year. They will be an even bigger factor in the next 15 years when more than 8,000 are expected to be built.

are financible today only with difficulty. The ratios of loan to value are lower, interest rates are higher, and loan terms are stiffer." Interest rates are, of course, the most readily discernible evidence of tight money, and they have risen from about $5\frac{1}{4}$ to $5\frac{1}{2}$ per cent a year and a half or so ago (following the tight money market of 1957) to around $6\frac{1}{2}$ per cent today. But there are other, more important, factors that the big lenders—a small handful of the largest life insurance companies—today weigh more carefully than ever: the location of the center, population, incomes, and retail trade volume of the trading areas; accessibility of the site; design; tenant selection; and building costs.

Architecture and site planning, particularly, are pored over more carefully than ever by insurance companies, some of which now have their own architectural departments. As centers have become bigger, and as the mall-type center (particularly those with a roofed mall) has dominated regional-center design, plans have become more complicated—and more expensive. John Jewett, vice president of Prudential Insurance Co., says: "The attractiveness of the design and layout is important in the promotion of centers . . ." yet he also claims that "there is very little say-so for the lender in either." While it is true that the lenders seldom make suggestions directly to the architect of a center, they have been known to turn down loans on the basis of design. Andrew Jackson, manager of the retail stores division of Equitable Life Assurance Society, says that "as a rule, we have little to say about design, although, of course, we can refuse to finance a center if we don't like it. As a consequence, the architect is sometimes asked by the developer to alter the design." Architect Kenneth Welch, who has designed several large centers, says: "Lenders heretofore looked at nothing but credit ratings, but now they are recognizing the advantages of attractive and efficient surroundings."

The lenders are pretty solid backers of the mall-type layout for large centers, and are becoming more favorable to covered malls, such as the new Char-

lottetown Mall in Charlotte, N. C. Jewett believes that the covered mall plan will prove a most successful design, but another lender, Edward C. Rose, of New York Life, feels that one drawback to this plan in some instances is the loss of perimeter parking space. Perhaps the biggest obstacle to the covered mall plan is its added cost, but developers such as James W. Rouse, of Baltimore, have been successful in convincing lenders that the cost of enclosure is well worth it, since heat loss, central ventilating, and air conditioning actually work out more economically than in individual stores each open on four sides. Rouse says confidently that "in five years, I don't think anyone will try an open-mall design for a large center." Less optimistic is Economist Homer Hoyt, who believes that the economics of the covered-mall design have yet to be proved, that their higher costs have not yet been justified by proportionately higher rental income.

While big lenders scrutinize design factors more carefully than ever before, what weighs most heavily in their decision to lend on a large shopping center is still the drawing power and credit of the main tenants, and this comes right back to the other influential factor in the whole development picture, the participation of a big retailer, usually a department chain store. Lenders today want to see a leasing pattern that usually results in about 70 per cent of all rental income covered by the minimum rentals of big-name tenants with AAA-1 credit ratings—that is, a net worth of over \$1 million. This means that minimum rentals from these tenants should cover taxes, mortgage interest, operating expenses, and, if possible, mortgage amortization.

The lender's insistence on having minimum guaranteed rentals covering these costs (usually resulting in some 70 per cent or more of the space being taken up by nationally known chains or strong local chains) has led Congress to explore the possibility of lease insurance for smaller retailers. But, at hearings last year, lenders and developers alike denied that small retailers were discriminated against as a result

of the policy, and they also doubted the need for lease insurance. Developer Rouse told the senators that the problem was not one of signing up the best from a group of independent retailers clamoring to get into a center, but one of finding them. All lenders agreed that strong independent shops are a vital necessity to any larger center to give it merchandising balance.

The big retailers

Demands of lenders for "top-name" credits have so strengthened the hand of the department stores that many developers consider they are being bullied by the retailers. Rouse says: "The department stores happen to be in a strong position. You could say they are our natural enemies in this business. But the fact is that without the department store, the center cannot exist at all."

Department stores are the key to the center's success, and the leases they sign show it. They pay the lowest minimum rentals (on the average, \$1.00 to \$1.25 per square foot compared to \$3 to \$4 per square foot for large, but local apparel stores). Department stores also pay the lowest percentage-of-gross rentals, too (1 to 2 per cent compared to 4 to 5 per cent for variety stores, 6 to 7 per cent for local apparel shops) and frequently the percentage drops lower with each \$5- or \$10-per-square-foot rise in sales. (Rentals are usually paid on a percentage of gross, but tied to a minimum dollar-per-square-foot figure which sets a rental floor.)

Although they are responsible for the emphasis on the need for big-name tenants, the lenders are nevertheless concerned about the kind of leases that department stores are getting from the developers. Bruce Hayden cites one developer who sought a mortgage loan on a center in which the department store's lease had a minimum rental of only \$1.10 per square foot. The debt service alone would have cost the developer \$1.19 per square foot, leaving nothing for taxes, insurance, plus promotional expenses and costs of maintaining common areas. "On the basis of minimum rents," Hayden adds, "the developer

continued on page 236

FRANK SCHERSHEL—LIFE



AIA honors a pioneer of modern architecture who is still pioneering. His row houses and apartment tower in Detroit's Lafayette Park are a case in point.

A medal for L. Mies van der Rohe

Even as the American Institute of Architects this month bestowed its gold medal on the master of steel expression, Ludwig Mies van der Rohe, the 74-year-old architect, born in the Rhineland, was enhancing his adopted land by completing a significant new architectural assignment in a typical American urban slum. The first of his Lafayette Park town houses in the Gratiot Redevelopment area of Detroit are occupied, and signs are that Mies, with this design, will amaze many who accuse him of dwelling in a steel and glass tower in the sky, remote from the down-to-earth problems of environment and living in the U.S.

In this redevelopment project his work has more than the usual structural poetry and the usual industrial significance. Mies has now added sociology to his arsenal: in the row houses arranged in a subtle domino game on the broad greensward before the 22-story apartment slab of Lafayette Park, he has designed a new version of this old kind of city dwelling. In this development there are 186 row houses, of two types: single-story houses with walled-in courts (two to four bedrooms) and two-story houses, with three bedrooms. They sell as co-ops at from \$20,500 to \$25,000. Like the courthouses he sketched in Berlin three decades ago, they are shaped severely and detailed with tasteful restraint. Like other Mies designs of the past, they are not only a reflection of a present architectural program for himself but may also be an intimation of a future pattern for many others.

Early photos are shown on the next four pages; next month FORUM will cover the development completely.

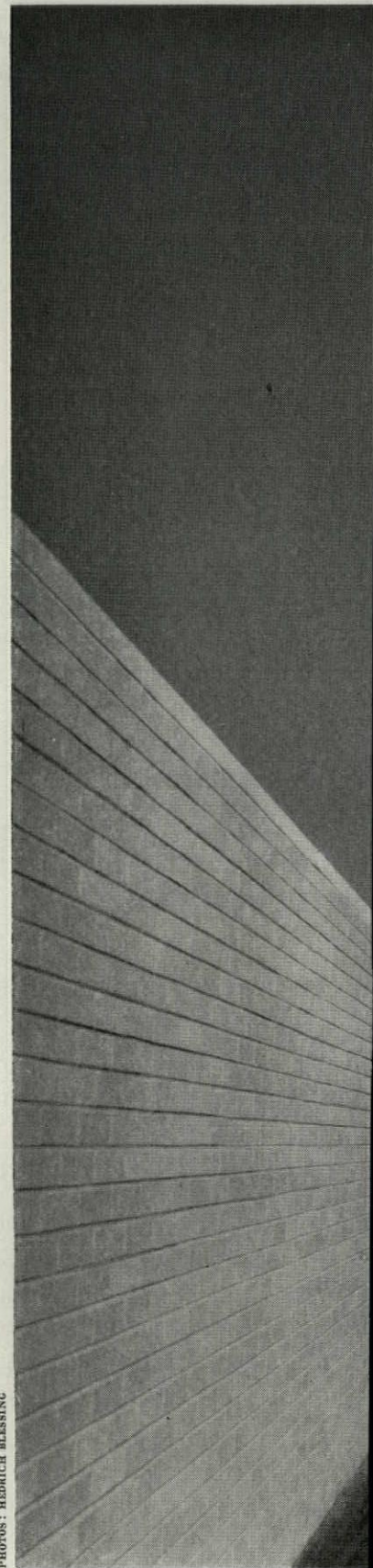
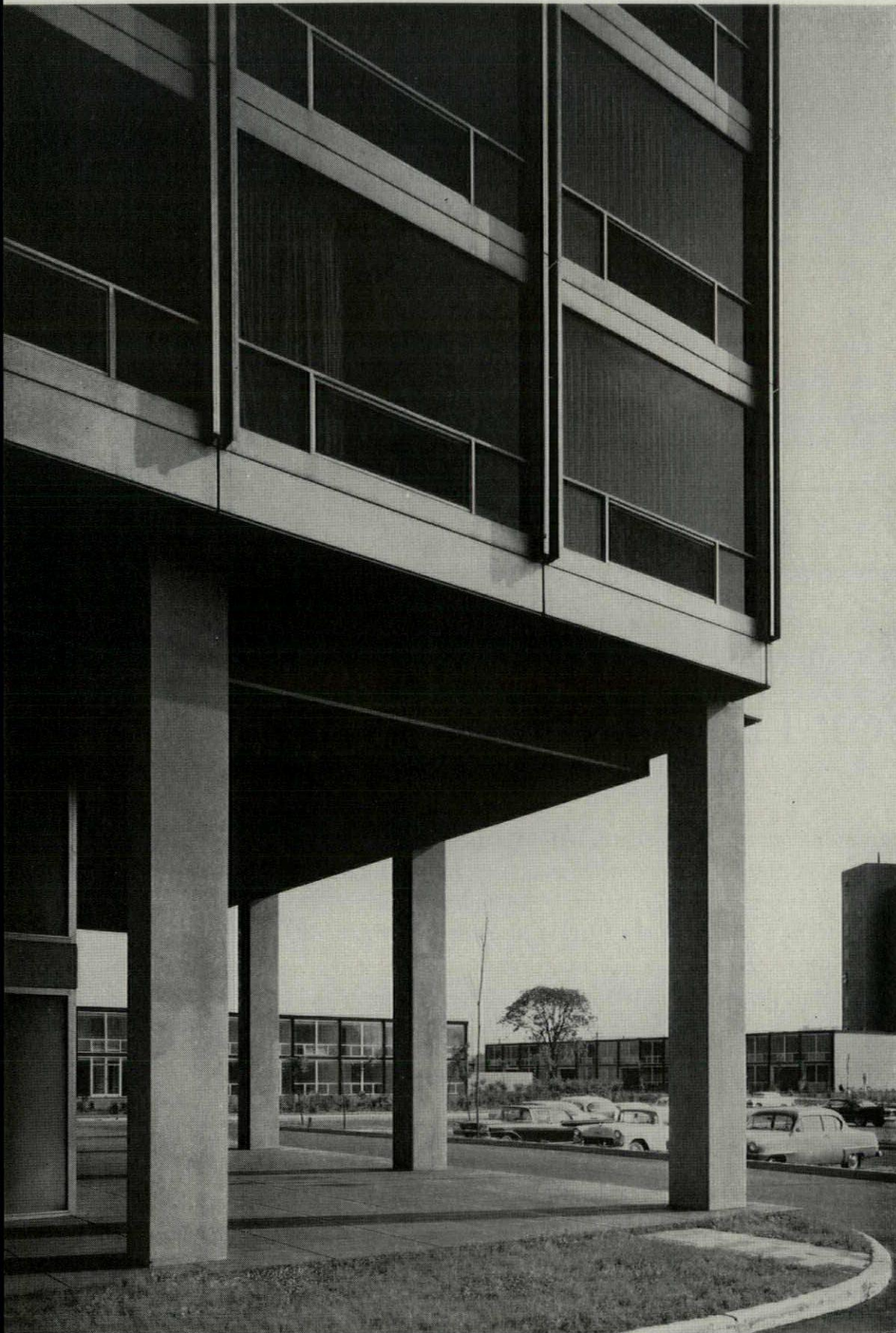

PHOTOS: HEDRICH BLESSING

Miesian articulation defines the differences in materials (concrete, aluminum, glass) . . .



... and the difference in building types. The tower lies across a divide from the neighborhood of row houses.



PHOTOS: FREDRICH-MESSING

Planes are related subtly in the design, and views are composed carefully. Brick walls enclose the private gardens (above) and the ends of the row houses (right). Streets and parking spaces are sunk discreetly below the level of lawns and paths to keep Detroit's shiny automobiles from dominating the scene.

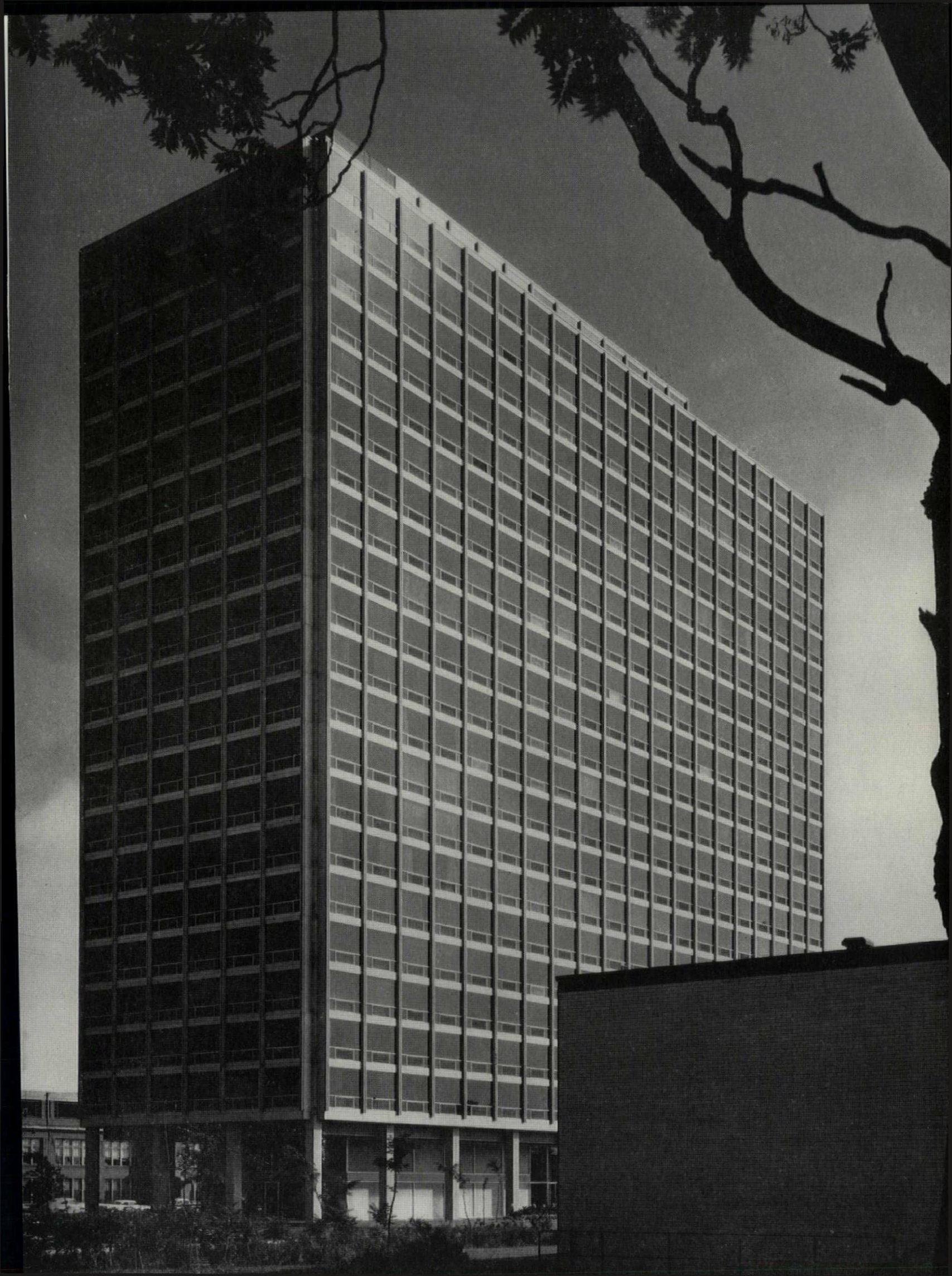

The new rivals: architects and

Now that architects design carpets and industrial designers tackle architecture, the building client is wondering who properly does what. BY RUSSELL BOURNE

Like a whimsical spring breeze, the news that the demonstration building at this year's Portland, Ore. Home Builders Assn. show will be designed by a team of industrial designers rather than by architects might be easily ignored. Even the report that Boeing's \$4.5 million research center in nearby Seattle is being designed by Walter Dorwin Teague Associates (industrial designers) might be dismissed as just another seasonal williwaw. Indeed, all the gusty indications across the country that architectural works of varied importance are falling to nonarchitect designers of various descriptions might be regarded as flukes—if it were not known that one of the continent's biggest plums, supervision of Montreal's \$13.5 million cultural center, had been blown into the office of The Raymond Loewy Corp.

The Montreal center is undoubtedly the most conspicuous example of the tempestuous relationship between architects and designers. And, in viewing this competitive relationship, it is just as easy to exaggerate the size and importance of things as it is to lose a sense of scale in a storm or in a rebellion. The fact can be lost sight of that architecture is a large, slow-moving body of historical thought, whereas industrial design is a far smaller band of diverse talents which have adapted themselves swiftly and cleverly to the changing demands of the U.S. economy. Architecture still displays its aristocratic lineage in its emphasis on excellence, order, and responsibility, while industrial design makes no secret of its origins in sales and its trust in popular taste.

Whether the changing architect-designer relationship is regarded as the most serious threat to Western Civilization since the Four Orders were howled down or as something less, it is clear that the peaceable ground rule which formerly ordered these matters no longer applies. The old rule was that designers would draft small items of equipment to be produced en masse and

architects would create large structures, long lasting and complex in function but vigorously unified in form. Now designers take part in the largest of man's endeavors, city building, and architects are found designing X-ray machines. Having come closer in recent years, the two disciplines now show signs of passing each other in swift pursuit of the other's origins.

Architecture for sale

For some 80 years civic leaders in Montreal had dreamed of building a concert hall that would give their city a cultural flavor appropriate to its international status. But each new effort to bring the dream to reality had run afoul of the many uncertainties of such a venture: exactly how many Montrealers could be counted on to show up for what kind of performance at what price? Therefore, when the latest effort was organized, the Sir Georges-Etienne Cartier Corporation's 21 members determined to conduct a thorough survey of the city's "cultural-economic potential." In choosing a research organization to manage this survey, they reasoned that an industrial designer should be most capable. "Anyone who can think through the complex problems of making—and merchandising—an automobile should be able to program an opera-house design," said Managing Director Claude Robillard. Seconding his suggestion (and, presumably, his trust in market surveys) was J. Bartlett Morgan, president of one of Montreal's biggest department store chains; a suburban Morgan's had shortly before been designed by The Raymond Loewy Corp.

Corporation members who might have been inclined to disagree with Robillard and Morgan, on the grounds that the functions of an opera house are after all not quite so simple as those of an automobile, designed merely to carry people somewhere, were soon overwhelmed by the massive, 150-page research volume that Loewy's Managing Partner William T. Snaith brought back

designers

six months later. By graphs and charts, as well as words, the research proved that the market for a full-scale, \$13.5 million cultural center existed, that culture was available to Montreal in certain forms having certain requirements, and that it was possible to package those forms and requirements in a popular design. Very little was said about the problem of giving architectural order to a complex group of buildings on a challenging urban site, for this was not an architectural proposal.

Yet so ponderously impressive was the survey that the Corporation decided to ask The Raymond Loewy Corp. to stay on as client's representative during the design phase. (Drawings for the center's first building—the concert hall—are now under way, prepared by Architects Affleck, Desbarats, Dimakopoulos, Lebensold, Michaud, Sise.) Snaith then faced the ethical choice of accepting or rejecting a commission that was a clear confusion of sales methods with artistic objectives. In the course of one week end, he determined to accept, dismissing all reservations to the contrary with the memorable phrase: "It seemed to me no damn different." It now remains to be seen what this strange combination of architectural creativity and industrial-design supervision will produce.

Snaith, who like most of the better industrial designers was originally trained as an architect, is frank in his eagerness to get more architectural work. He admits that his architectural esthetics are not very grand: "That's the trouble—architects are the prisoners of their own esthetic systems, they're priests dedicated to the theology of structure, they don't give a damn for human needs. Look at all these architect-designed stores with four glass walls! How do they help man? Everyone knows that a glass wall is the enemy of good interior retailing." He, on the other hand, puts strong emphasis on "human needs" although the words can be very easily confused with popular taste or what people are willing to pay for.

He is particularly fond of demonstrating how many more human needs will be met by the concert hall at Montreal

than by Lincoln Center's Philharmonic Hall. "The function of both these halls is to introduce people to symphonic works," he says. "Can you imagine anything more ludicrous than interfering with that purpose by restricting the number of people who can be admitted, for the sake of a few decibels?" He was referring to the fact that the hall at Lincoln Center, designed by Architect Max Abramovitz to replace the existing Carnegie Hall, will have only 2,600 seats (and a reverberation time of 1.9) whereas the hall in Montreal will seat 3,100 (and have the lower reverberation time of 1.7). Apart from betraying a quick readiness to sell out quality of performance to numbers, Snaith's question left untouched other important architectural questions dealing with

such intangibles as scale, relationship to environs, and the complexities of listening to music.

New faces

Not only Canadians but even the clients of New York's confident corporate towers have evinced a remarkable uncertainty in the matter of whose leadership, architects' or designers', should be followed. "Architects have a structural purpose," says Herman Maser of the Bankers Trust's real estate department. And in that succinct statement he fails to note the world-famous new look given by Architects Skidmore, Owings & Merrill to the Manufacturers Trust building almost directly across the street. He goes on: "Architects' function is to execute buildings according to the building code—not to give someone like us a corporate face." Bankers Trust has indeed been given a corporate face by Designer Henry Dreyfuss, a smiling if somewhat dull face, that is seen in everything from its "in" boxes to its series of new branch banks in and around Manhattan. Dreyfuss, who reiterates that he is not looking for architectural work, says that he was willing to do for Bankers Trust what he would not do for many another would-be architectural client because "it was an obvious extension of their merchandising program and corporate identity—besides, we always insist on having an architect help us."

Although clients generally admire the designer's way with a corporate identity problem, not all of them are willing to let designers go whole hog—or, in the case of Socony Mobil, whole horse. For

when it came to a point where Socony's face-maker, Peter Schladermundt, might have been chosen as the logical designer of the interior space for the company's steel-plated headquarters near Grand Central Terminal, he actually was not. One reason was that Socony did not understand that Schladermundt, an architect-trained designer, also did interiors. He was considered by Socony's management simply as the man who had succeeded in integrating the wings of the "flying red horse" into the de-

continued on page 241



Rooms for worship

From one architectural office in South Dakota comes this trio of handsome interiors, each for a different denomination.

The fact that in a single year these three churches were completed in Sioux Falls, South Dakota (population, 65,000; total cost of churches, \$2 million) is but one hint of the immense volume of church work now taped on architects' drafting boards. The fact that the same South Dakota architects, Harold Spitznagel & Associates, executed all three—the prize-winning Roman Catholic Church of St. Mary (1), First Presbyterian Church (2), and Our Savior's Lutheran Church (3)—is an indication of the interdenominational appeal of one firm's spare but sturdy approach to church design. Another common denominator: although the three churches vary considerably in cost, each saved a considerable slice of its budget for art, and none approached its art in the conventional archaeological way.

Despite shared characteristics, each of these churches has its own specific character, more evident in the interiors (right and next two pages) than in the traditionally solid masonry exteriors (left). As seen from the outside only one, First Presbyterian, pitches a tall, tile-shingled roof atop its old rose common brick walls in the currently stylish manner. But all three, washed as they are of antique detail, reach upward: St. Mary's with a trio of masonry piers between which carillon bells are slung; First Presbyterian with a cupola riding its roof over the chancel; and Our Savior's with a slim brick bell tower supporting a cross. This part of South Dakota is level land under a large prairie sky, and silhouette is what counts strongest in architectural symbolism.

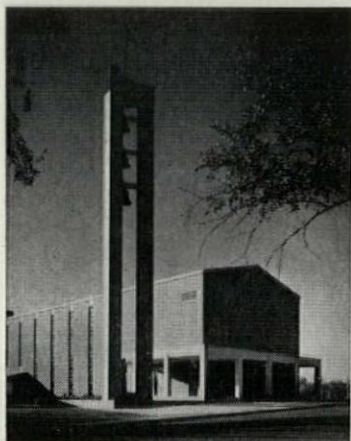

1

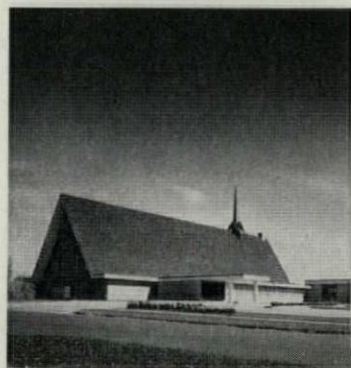

2

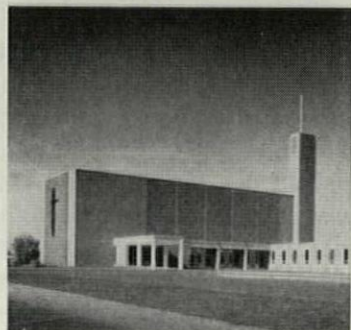

3

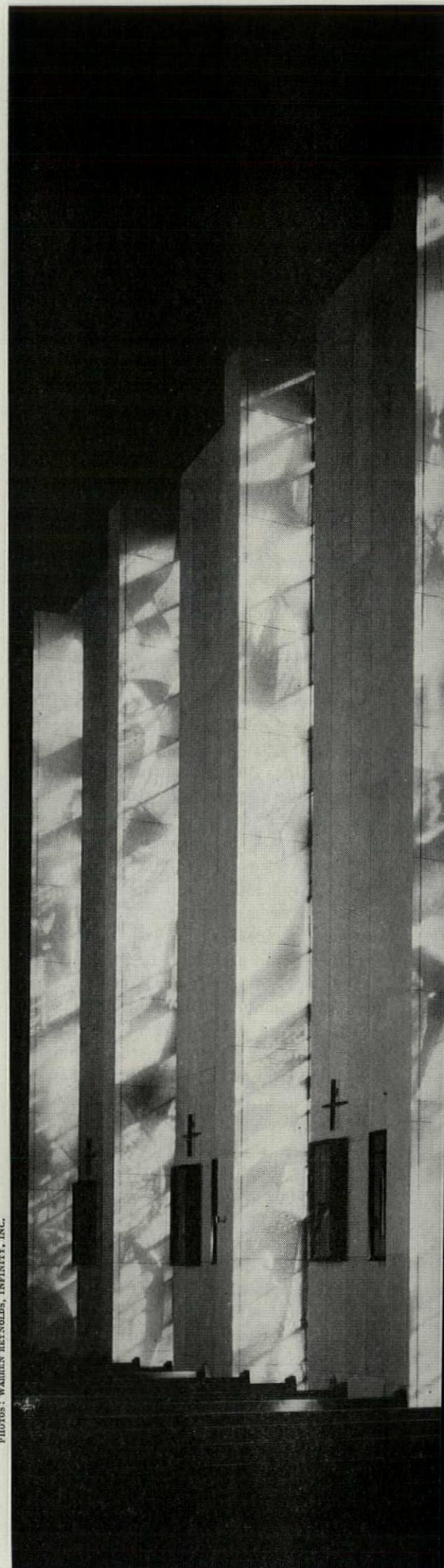

PHOTOS: WARREN REYNOLDS, INFINITY, INC.



1

Slim stained-glass windows by Emil Frei and Robert Harmon along the side of Church of St. Mary alternate with paintings by Robert Rambusch depicting the Stations of the Cross. The photograph below looks forward the full length of the nave toward the sanctuary, which is flooded with daylight from above. The walls are face brick veneer on the exterior with block backup and Winona travertine interior veneer; the roof structure is laminated wood beams and purlins. This church seats 850 and cost a total of \$351,000—about \$23 per square foot. Last month the building was awarded a silver medal for elements of its design and craftsmanship by the Architectural League of New York. The project designer for Spitznagel was W. E. Bentzinger; the general contractor: Henry Carlson Co.



2

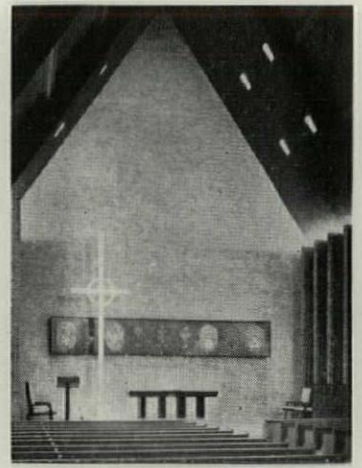
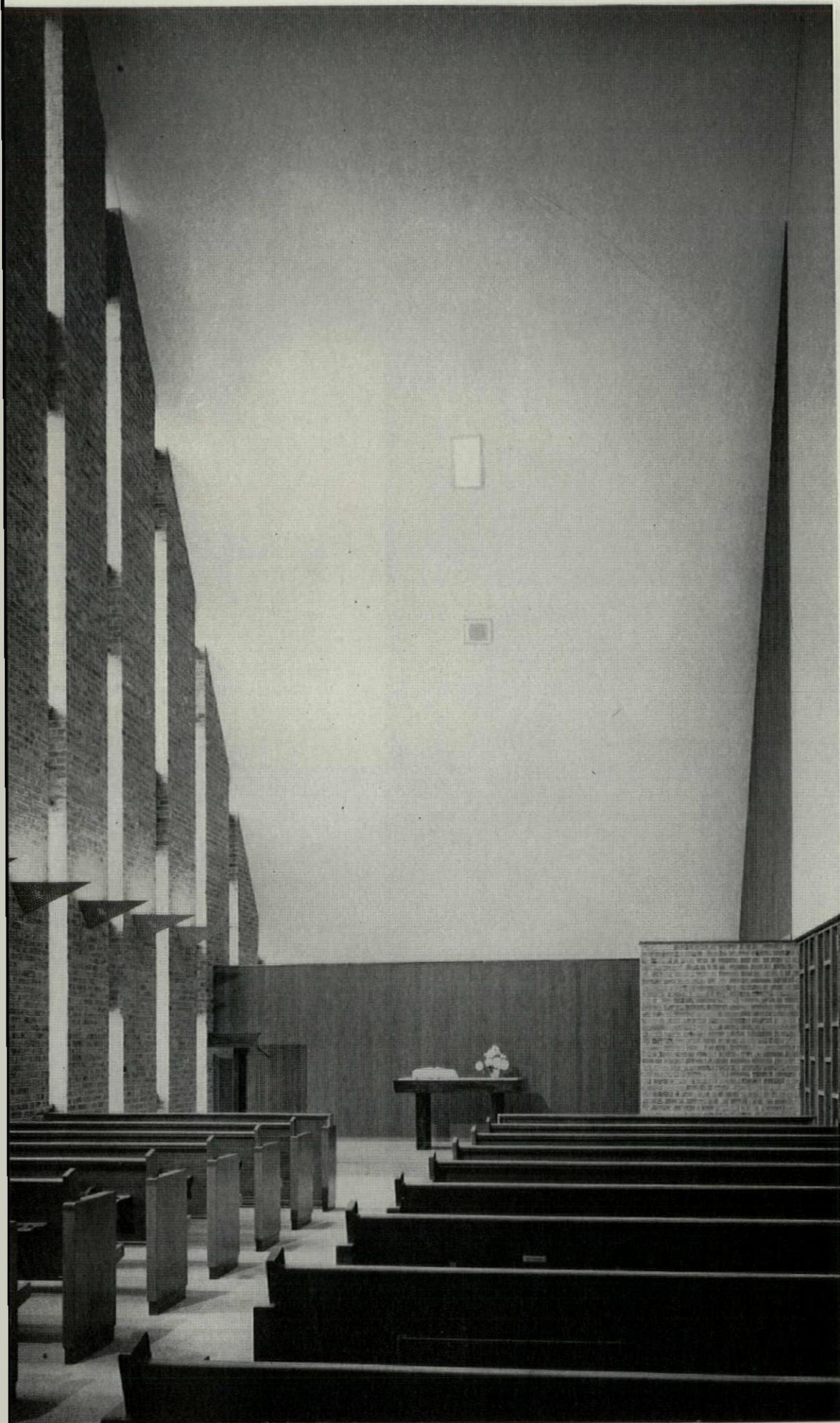

The chapel in the First Presbyterian Church (left) lies across one end of the tent-shaped building. Attention is focused on the altar by simple means: the ceiling slants down behind the altar's grooved wood paneling and is lighted by fixtures aimed upward from behind the unfinished brick wall. Staggered slot windows light the participants. The nave of the church proper (above) follows the roof peak; the chancel wall bears a ceramic mosaic panel by Palmer Eide using symbols to portray the life of Christ. This church seats 500 in the nave, 100 in the chapel, 50 in the balcony, and cost a total of \$551,000—about \$15.50 per square foot. The project designer for Spitznagel was Wallace S. Steele; the general contractor: G. L. Gullickson Construction Co.

3

The small chapel in Our Savior's Lutheran Church seats 120 for weddings, funerals, and other services, and is housed in a wing parallel to the nave of the church. A massive red cross is set out from the chancel wall and lighted from the left by a narrow window extending from floor to ceiling, a type of lighting which picks up the textures of the white-painted bricks. The altar is black marble, and the fixed baptismal font is spun aluminum. Including this chapel and overflow seating in the narthex the church seats 1,020 and cost a total of \$750,000—about \$16.40 per square foot. Project designer for Spitznagel: W. E. Bentsinger; general contractor: Sioux Falls Construction Co.





Sealed and unsealed offices, as seen in Lever House and non-air-conditioned building in Rockefeller Center, reveal their differences from across the street. Both pictures were made on a sunny afternoon in late February, both show south-facing windows. In the air-conditioned space, a larger proportion of the Venetian blinds are lowered to the sill to reduce solar heat gain. In some offices of the nonair-conditioned building, windows are obviously opened (more are probably open than can be seen) to compensate for solar heat gain. The sun problem is more acute in buildings with inoperable windows.

The problem of the sealed building

Natural hostility to controlled environment can be countered only by designing the air conditioning to suit the space. BY HENRY WRIGHT

Undoubtedly the most significant innovation in the current crop of office buildings has been sealing the windows. In effect, the designer and owner are telling the tenants: "Don't touch the windows; the mechanical system knows more about keeping you comfortable than you know yourself."

The ordinary person's reaction to this claim is apt to be less than enthusiastic, if only because it is a challenge. Indeed, the air conditioning of any sealed building is likely to arouse the ire of some of the occupants, no matter how "good" it may be. And a system which does not work will inspire rebellion among the occupants. An example: A mild-mannered, law-abiding corporate executive finds himself imprisoned behind a wall of glass in a new Manhattan skyscraper. He can look out and see the springtime, but the air he breathes is stale and warm. So the law-abiding man becomes a felon; he steals a key from the maintenance room—the key used by window-washers to unlock the windows so that they can be spun around for cleaning. The man tests the fresh, spring air until the alert building managers detect a leak in the system, trace it to its source, and, presumably, punish the nonconformist for his crime.

Why was the man compelled to steal the window key? Why did the building managers not provide their tenants with windows that could be opened? To the air-conditioning engineer, the answer is obvious: an air-conditioning system cannot function if there are leaks. It cannot be turned on on Monday, off on Tuesday, and on again on Wednesday—or off in one office while on in another. Perhaps this point should be made to the new occupants of an air-conditioned building, and they should be educated to the capabilities (and incapacities) of the system, to placate their natural hostility to a controlled environment.

There are half a dozen complaints most likely to be heard against air conditioning; each has its basis in psychology; by checking the effects against

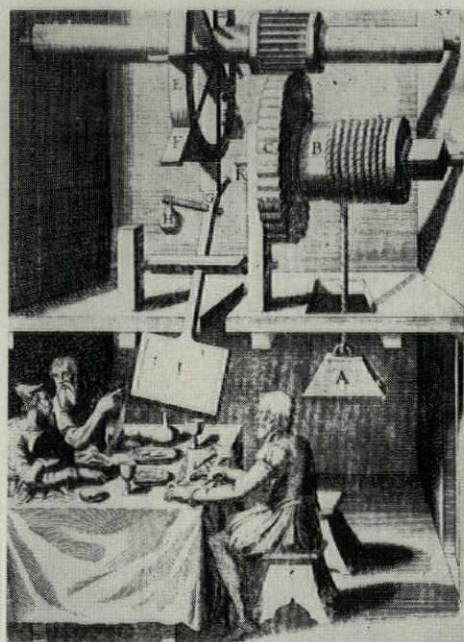

Sealed conference room, as conceived by an architect in 1660, relied on air conditioning of a kind. The idea seems to have been to keep the air moving, rather than to replace it, but then, none of the occupants was smoking, as would be the case today.

the characteristics of various air-conditioning systems it is possible to make a most intelligent selection. As will be shown, there is no single system which is best for all applications.

The six most commonly expressed complaints regarding air conditioning relate to: odor, noise, drafts, overcooling, overheating, and stuffiness. In relative importance these will vary with the environment in which each is experienced (see chart, page 148). For example, a noisy air-conditioning system will be less objectionable in a noisy restaurant than in a quiet hotel or office building. And an overcool lobby occupied for a moment will be less objectionable than an overcool office occupied for a day. Air conditioning comes in many generic types, each with advantages and disadvantages. For instance, it is almost universal practice, these days, to use a different kind of system in the interior portions of an office building from the kind used for the space adjoining the window walls. Air

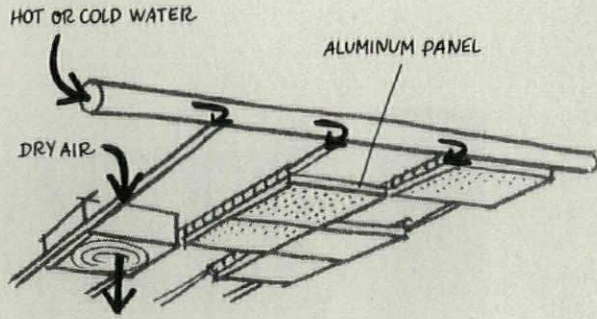

Radiant panel heating and cooling, as used in the Alcoa Building, relies principally on water coils in the ceiling for heating and cooling. In summer, a small amount of dry, conditioned air is supplied to control humidity and preclude condensation on the panels.

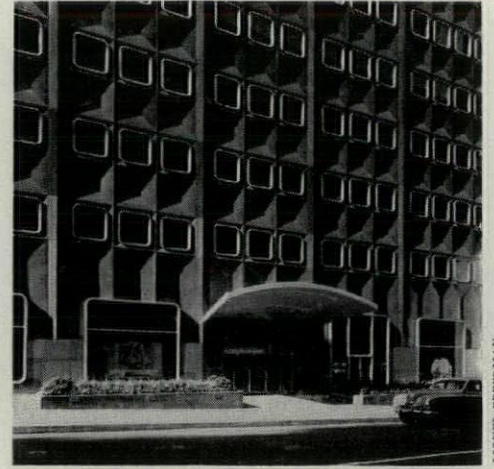

LIONEL FRIEDMAN

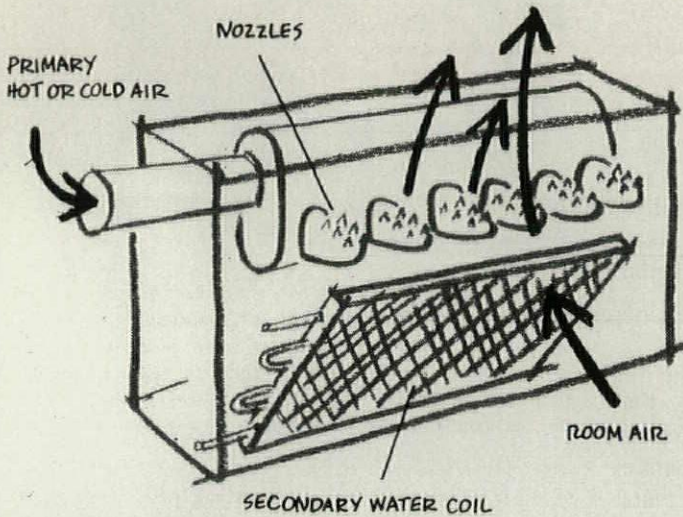

Induction air conditioning, as used in the perimeter spaces of the Seagram Building, releases a relatively small amount of conditioned air through special nozzles which "induce" room air to flow through a finned coil, where it can be heated or cooled. The coil is supplied with hot or cold water.



© EBRA STOLLER

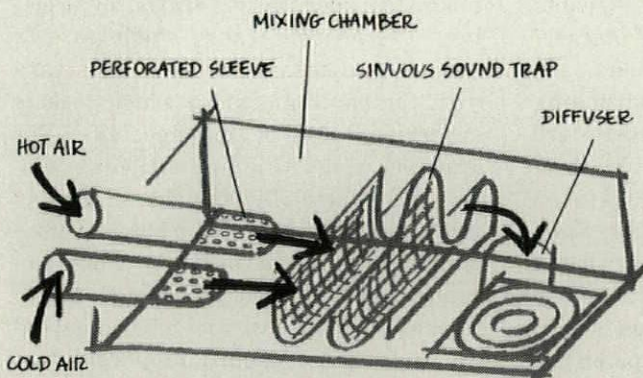

Double-duct high-velocity air conditioning, as used in the Blue Cross-Blue Shield Building, delivers both hot and cold air to each room where it can be mixed in any proportion to supply either heating or cooling as required.



conditioning the "core" is essentially simpler and demands less complicated equipment than the periphery; there is no point in providing a high degree of flexibility in areas where the cooling load is practically constant, and does not even vary significantly in winter as compared with summer. Thus, in selecting a method for air conditioning a new building, the evaluation should begin by rating these six commonly expressed complaints with respect to various types of space.

ODOR is a subtle sense impression with psychological sources. Either a person is aware of the "strange" odor of an air-conditioned space when he first comes in or he is likely not to notice it at all, since awareness of a constant odor falls off rapidly when the stimulus is sustained. However, in a space where heavy odors are likely to be encountered, as in a restaurant, and where they cannot be allowed to remain, it is essential that the air-conditioning system be designed to introduce new air in great quantities. To make even a barely perceptible difference in odor intensity, the rate of ventilation must be doubled; to positively improve the condition another "step," it must be doubled again.

NOISE is another complaint with a complex basis. For example, a person entering an air-conditioned motel room is likely to be more disturbed by noisy air-conditioning equipment if the evening is mild than if the weather is hot and sticky. Because he is in a room intended for sleeping, this disturbance is accentuated. But the same person may be quite undisturbed by the equally intense (but familiar) traffic noise that results if he turns off the air conditioning and opens the windows. Similarly, a man all by himself in an air-conditioned office may find the soft, hissing noise of an air inlet intolerable in its persistence.

Cooling can be accomplished within any specified limit of noise production, including no sound at all, as with panel cooling. The question of what stand-

ard to maintain depends to a large extent on the occupancy and use of the air-conditioned space.

DRAFTS which create a definite consciousness of air movement may or may not be interpreted involuntarily as a defect in an air-conditioning system. The reaction will depend on whether the person is comfortable already or whether he wants to be cooler. In the lobby of a building, air delivery downward from the ceiling in localized form may provide areas of supercooling into which people entering the building on a hot day can step and cool off pleasantly. The inescapable draft which hits a hotel bed is another matter; it is felt as undesirable because exposure is compulsory for many hours.

Drafts are most likely to occur where the cooling load is high, i.e., a great deal of air must be circulated to do the cooling job. Motel rooms are notorious offenders, because their large exposed roof areas soak up solar energy, and their air-conditioning systems are designed to cool the rooms quickly with a big rush of air after long "off" periods. In other building types, particularly office buildings, the need for extra cooling to carry off the heat generated by the new lighting often intensifies the draft problem.

OVERCOOLING EFFECTS are usually caused by human error. They often result from setting the thermostat at the lowest possible point, the theory being that if a little cooling is a good thing, more cooling must be even better. (Bellhops are strong adherents of this school of thought.) But where overcooling is not the result of misguided zeal, it is most frequently caused by poor control. In a large building, for example, which should be controlled on a zone basis, the attempt is made to economize by cooling each floor as a single zone. The result is overcooling on the shady side of the building and undercooling on the sunny side.

Overcooling is also common, paradoxically, where the total air-conditioning capacity of the system is inadequate

to meet the peak load, as in restaurants, where an effort is made to cool the room to its lowest point before periods of peak occupancy. As in the case of drafts, one's awareness of overcooling is primarily a function of length of occupancy—the longer, the "cooler." Overcooling is most resented in situations in which people are unable to move around and increase their body heat production.

OVERHEATING is a common complaint in a building which is cooled by a centrally controlled air-conditioning system which does not provide unit controls in each office. The maintenance engineer must determine the comfortable temperature without regard for individual preferences or load conditions. For example, the rooms on the south side may be already overheated by solar heat gain, while the rooms on the north are cool. If the north rooms are to be made warmer, warm air must circulate through the entire system, but the south rooms will be overheated. In fact, in buildings with large glass areas, the south side may actually require refrigeration cooling while the rooms on the north require heating. Most modern systems are able to avoid this dilemma by breaking the system into zones, whereby the warm areas receive cooler air and the cooler areas, warmer air. More sophisticated systems, such as an induction or a double-duct system (see diagrams, opposite page) reduce the possibility of overheating by providing individual thermostatic controls in each space.

STUFFINESS is a word that has long been used to describe anything invidious which a person feels about his building's air-conditioning system. People usually complain of defective air conditioning in vague, general terms. Defective air conditioning and human reactions to it are partly a matter of physics, partly physiology, and all register psychologically. Thus, a system which lacks a separate control of humidity may account for certain "stuffiness" objections, or complaints of

TYPE OF COMPLAINT	PERIPHERAL PRIVATE OFFICES	INTERIOR GENERAL OFFICE SPACE	CONFERENCE ROOMS	LOBBIES
ODORS			mixture of recirculated air may cause complaints	contrast from outside heightens odor perception
NOISE	quiet of office accentuates sound perception	mixture of sounds obscures air-conditioning noise		
DRAFTS		fixed furniture arrangements may increase complaints		localized cooling may be asset in warm weather
OVERCOOLING	individual control obviates problem	variety of temperaments difficult to satisfy		may be asset
OVERHEATING	solar effects create winter cooling problem		crowded rooms may need cooling even in winter months	
STUFFINESS			variety of temperaments difficult to satisfy	

Air-conditioning complaints vary with the type of space use, as indicated in this table. Dark gray areas represent the greatest amount of criticism or sensitivity to a particular defect, light gray areas fewer complaints, white areas least critical conditions.

Notes in small type suggest some reasons for these ratings. By relating the relative importance of these factors to the advantages and disadvantages of different air-conditioning methods, the best and most economical system for a given application can be determined.

"clamminess." The effects of overheating are ordinarily attributed to "stale" air. In other instances, such words may signify nothing more than that the person is unaccustomed to his new air-conditioned environment.

The degree of importance to be attached to any of these air-conditioning shortcomings must vary greatly with the type of building and the use to which its various spaces will be put. There are few buildings which justify the cost of a system which is completely odor-free, noiseless, draft-free, etc., even though such a perfect system is attainable if the building owner is willing to pay for it. Practically speaking, a less-than-perfect system must be chosen, in which the effects considered

most objectionable are, of course, carefully eliminated.

This is an important point for the building owner to grasp, for the ultimate effectiveness of his building's air conditioning will depend upon the suitability of the particular design to the particular building. Most of the objectionable features of faulty air-conditioning systems are independent of the quality of the equipment itself.

The trouble which an air-conditioning system can cause is roughly proportional to the magnitude of the cooling job presented by the building design. Thus, quality air conditioning in a sprawling, single-story building is more difficult to achieve than in a multi-story building. Similarly, a properly

oriented "slab-type" building, particularly in the south, presents a simpler cooling problem than a square tower, and involves much less need for zone control. Until these facts are impressed on building owners, who do the buying of air-conditioning systems, whether from the air-conditioning engineer's designs or otherwise, the demand for really good systems will remain, as now, largely unheard. Awareness of the difference between poor air conditioning and good must take the form of specific objections to the performance of today's systems. It is necessary to categorize these objections, to relate them to surrounding conditions—with a view to discovering whether they would be equally objectionable under

other circumstances—and to learn what particular features of air-conditioning design are capable of correcting or minimizing them, including the kind of systems especially suited to solving unusual cooling problems.

Selecting the system

Of all the fallacious beliefs surrounding the science of air conditioning, perhaps none is more widely held than that which offers hope for a system which can demonstrate superiority under any building condition. Of course, the ultimate value of any system is bound up with the kind of building it inhabits and, therefore, it is illogical to assume that a good system in one building will perform as well in another. A case in point is the heating-cooling system in Pittsburgh's Alcoa Building. This radiant system (see sketch) has performed well and economically for eight years, but its satisfactory performance is due largely to the kind of building it is in, i.e., a building with relatively small windows. The same system would make less sense for a Seagram Building or a Lever House, buildings with large glass areas, because of the tremendous cooling loads on those buildings' outside bays. Similarly, a radiant system would probably not be used in spaces where large groups of people congregate, as in department stores, because they generate excessive moisture whose removal requires great quantities of air coming in and going out of such spaces. The effectiveness of panel cooling in such instances would be negligible.

The basic systems

Most people think of air conditioning as simply a central system which supplies warm air in winter and cool air in summer, and thus makes up for the heat loss or heat gain in the enclosed space. Indeed, the traditional system works in just this way; it is appropriate for the heating or cooling of interior spaces of office buildings, where the heating and cooling loads are likely to be uniform and seasonable.

However, the single-duct central system runs into difficulties when it is imposed on an entire building—including the peripheral offices as well as the

interior spaces. Spaces which are likely to be densely occupied, such as conference rooms, may require cooling even in winter to offset body heat released by the occupants of the room. Although a "conventional" system can be arranged, through zoning, to solve such problems, only a system which is capable of simultaneous heating and cooling can handle all situations.

To provide simultaneous heating and cooling requires a more refined system. Instead of simply feeding the same kind of air into all spaces, the more refined system uses two air supplies, carried through two ducts, one carrying warm air and the other, cold. In this system, both cold air and warm air are supplied to all areas at all times. Its ducts terminate at mixing boxes within each space, usually located in the ceiling; the mixing box acts as a noise silencer and makes possible thermostatic control for each room. Thus, the temperature of the incoming air can be varied to balance with the heat gain or loss of the space. An inherent problem with the double-duct system is its relatively high noise level; this is due to the high speed at which the air travels through the ductwork. Great care is required to minimize this difficulty, particularly in the design of the mixing boxes.

The double-duct system is not applicable in buildings which require very long duct runs, because of the difficulty of moving great quantities of air over long distances.* To provide cooling for these spaces, e.g., the high-rise office building, another system has been developed. This is the induction system, which uses both air and water for heating and cooling. With the induction system, less air is moved than with either conventional or double-duct cooling, because about 80 per cent of the heating and cooling is supplied by water. The induction system is widely used in the peripheral spaces of office buildings: air and water are fed to a cabinet under the window, and the air is released within the cabinet in such a way that air from the room itself is induced to circulate through it. This

*Double-duct systems are frequently installed, however, in large buildings being converted to air conditioning.

air passes through a finned coil supplied with hot or cold water; in hot weather, the coil is cold, thus chilling the air as it passes the fins. In cold weather the coil is usually hot, to provide heating.

The simultaneous supply of cool air to a group of induction units and of hot water to the coils makes it possible, by controlling the water valves, to heat one room while cooling another. With this system, the maintenance engineer has a rather wide spectrum of heating-cooling possibilities: for the warmest spaces, he can supply cool air and cool water; for the coolest, he can supply warm air and warm water. And for less extreme needs, he can supply other combinations, thus providing the building with a variety of heating-cooling possibilities.

Induction systems are inherently quiet, making them especially suitable for peripheral spaces; moreover, they permit rather good control of humidity, as well as temperature. The pattern of air distribution with an induction system is appropriate for small offices, and particularly for offices with large glass areas.

Radiant panel heating and cooling is used less frequently in modern office buildings, principally because it is less capable than an induction system of coping with the wide fluctuations of heat gain and loss caused by the large glass façades. In some respects, a panel system is quite similar to an induction system: instead of cold water being circulated in a finned coil under the window, the water is circulated above the ceiling. The new air, which was brought into the room at the window unit by an induction system, can be introduced at any point in the room. The function of the new air is simply to keep the room air dry. (In the case of the Alcoa Building, this air is introduced through small ceiling diffusers.) Radiant heating-cooling is obviously the *de luxe* air-conditioning system. It is completely noise-free; there is less chance of mixing odors with this system. But it is the one cooling system which cannot be imposed upon any exterior design; if a radiant system is to be effective, the building's design must match with the system's capabilities.

Conveyors for shopping . . . tax bounty for churches . . . incubators for industry

? *How to deliver shopping-center customers' packages to convenient parking area locations some distance from main store buildings.*

! *Install continuous chain-conveyor systems to tow shopping carts to and from satellite loading areas in the parking fields.*

When the Jewel Tea Co. first considered opening one of its big stores in the new Hillcrest Shopping Center in Joliet, Ill., the proposal seemed impractical, because the store would be more than 200 feet from the edge of the parking area. Few customers could be expected to carry large bundles or to push loaded shopping carts such a distance, and then as much as 600 feet farther to their individual cars. Nor could customers be expected to return empty carts such distances.

The problem was solved, however, when Chester H. Cole, Jewel's construction and maintenance engineer, studied modern factory and warehouse materials-handling systems and designed a continuous-chain conveyor system to tow shopping carts to and from a special drive-up loading platform at the edge of the parking field. At the check-out station in the store, a customer's packaged purchases are loaded into a shopping cart. He is given an identification check that matches a duplicate attached to the cart, which is then hooked onto the conveyor chain and promptly towed out to the sheltered parking area platform. There the cart is

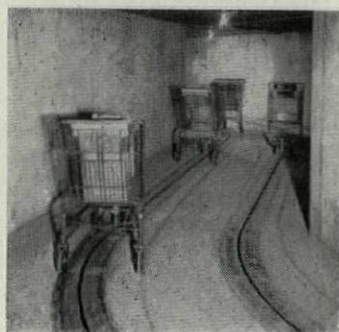

kept safely by store personnel until claimed, and the shopper can make other purchases in other stores in the center if he wishes without immediately having to pick up his first purchases.

The conveyor system, which also returns empty carts to the store, is operated through an underground tunnel (see cut). In adaptations of the system, however, carts also could be towed through enclosed or screened surface passageways inside or outside of buildings, and lines could be run to a whole series of loading stations at strategically convenient points in different sections of extensive parking areas.

? *How to acquire an existing building for a nonprofit institution at substantial savings to both buyer and seller.*

! *Show present owners the tax advantages—even the net financial gains—they may achieve if they give rather than sell an institution part of a property's value.*

Religious, educational, and other nonprofit organizations often lack adequate resources to build brand-new accommodations, but can use existing buildings, after remodeling or modernization. Last year, for instance, Congregation Shaaray Tefila in New York moved into a temple remodeled from a movie theater by Architects John J. McNamara and Horace Ginsbern & Associates.

What makes this conversion noteworthy is the astute manner in which the property was acquired at a bargain price—and in part as a contribution that the previous owner could advantageously afford to make to a nonprofit purchaser but not to an ordinary buyer, because of federal tax rules.

A building held in one ownership for many years usually has had a large portion of its value depreciated for tax

purposes, explains New York Builder Gerard Oestreicher, a member of the congregation who helped negotiate the purchase and also supervised the reconstruction without charge. If a building is sold at market value, which normally is greater than its tax-depreciated value, the seller must pay a capital gains tax on the difference. If an owner sells a property to a nonprofit institution at its tax-depreciated value, however, he is allowed to treat the difference between this price and the property's normal market value as a tax-deductible contribution to the institution, and both parties can benefit substantially. Having realized no profit, the seller does not have to pay any capital gains tax and can retain the full proceeds of the sale portion of the transfer. Moreover, after deducting the value of the gift portion of the transaction from his other taxable income, the seller has a smaller tax to pay on that income. In higher tax brackets this might even give the seller a net cash gain for himself. In any event such a deal would be infinitely better than first selling the property at full market value and then making a cash contribution to the institution, which would require that a capital gains tax be paid.

The big advantage for any nonprofit institution in this kind of a situation is its ability to purchase an existing building at less than ordinary market value without any corresponding decrease in net income for the seller. The institution can either save the difference, if the building is already suitable for its purposes, or spend it on whatever remodeling may be necessary.

Alternatively, the institution can resell the property for its full market value without tax liability and then apply the entire proceeds to the purchase of another property or the construction of a brand-new building.

? *How to attract new plants to an industrial park without compelling them to sign up immediately for a long term or to lease or erect an entire building.*

! *Erect a multitenant "incubator" plant for pilot operations of prospective tenants and small firms, who get options to have their own buildings erected later.*

Most large industrial parks are interested only in tenants large enough to occupy an entire building or group of buildings. However, many small firms would like to locate within a good industrial park, and these firms may be able to order buildings of their own later on after they are better established. Then again, a U. S. firm recently wanted to test its new Canadian operation before committing itself. The plant site was in the 200-acre Flagarwood Holdings industrial park in Trafalgar Township, near Toronto.

To accommodate such operations, Flagarwood officials broke ground in October for a small 30,000-square-foot "incubator" building, with four distinct wings of 7,500 square feet each, plus a central office and reception area. Designed by Bregman & Hamann, Toronto architects, this building has a prestressed concrete frame with beams providing a 45-foot clear span for industrial operations, and it will cost about \$8.25 per square foot. Small tenants may rent from one to four of its wings for \$1 per square foot net for terms of only two to three years, with or without options for subsequent construction of larger buildings of their own. On long-term leases the park will erect these latter buildings to the tenants' specifications and rent them for 80 to 85 cents per square foot.

Flagarwood's officers also hope to gain from the industrial diversification spurred by the incubator plant. **END**

IT'S
EASY TO
"PINPOINT"
THE
PROPER DRAIN
WHEN YOU USE

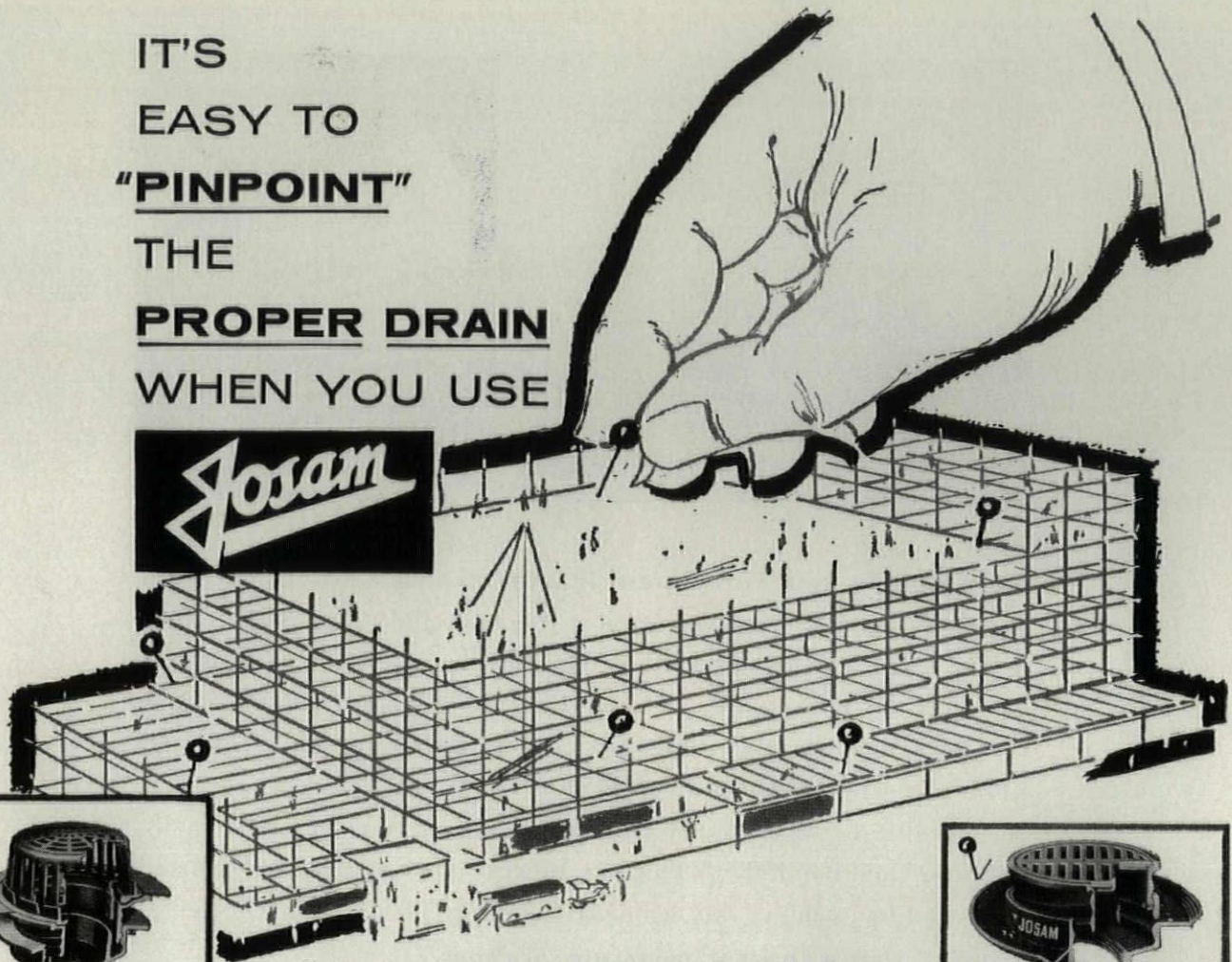

Series No. 4550
"Leveze" Adjustable
Roof Drain



Series No. 4010
Promenade Deck
Roof Drain



Series No. 300-35C
Shower Drain with
adjustable strainer



Series No. 5440
Non-Clog
Floor Drain



Series No. 680-V
Industrial Drain with
tractor grate

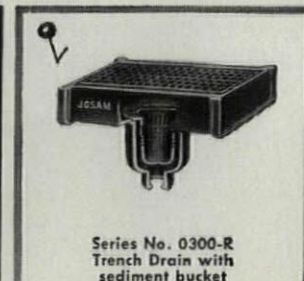

Series No. 0300-R
Trench Drain with
sediment bucket



Series No. 3510
"Leveze" Adjustable
Floor Drain



Series No. 7020
"Super-Flo"
Floor Drain

Isn't it satisfying to know that wherever you indicate a drain . . . whatever the drainage condition . . . from roof to basement . . . that you can get the exact drain you need from Josam? This means that you can save countless hours of time . . . avoid guesswork and error . . . assure maximum service on every job, simply by checking with Josam first.

The Josam line of drains today is the most complete in the industry because it has been constantly expanded to meet the changing needs of advanced building. As a result Josam drains are engineered to install easier . . . perform better . . . yet cost no more than ordinary types. Don't waste a minute when you have to "pinpoint" any plumbing drainage product — call Josam. You'll be time and money ahead.



JOSAM MANUFACTURING CO.

General Offices and Manufacturing Division
MICHIGAN CITY, INDIANA
REPRESENTATIVES IN ALL PRINCIPAL CITIES

West Coast Distributors
JOSAM PACIFIC CO.
765 Folsom Street San Francisco 7, Calif.

Josam Products are sold through plumbing supply wholesalers.

JOSAM MANUFACTURING CO.
Dept. AF-4, Michigan City, Indiana

Please send Catalog K showing complete line of drains.

Firm

By Title

Address

City Zone State



Atlantic Coast Line Railroad Bldg., Jacksonville

Federal Reserve Bank Bldg., Chicago

Gold Bond's new Fire-Shield Plaster gave these two buildings full fire protection in one sprayed-on-coat. It gives cellular steel decks a four-hour rating when sprayed $\frac{5}{8}$ " thick after the flutes are filled. Corrugated decks get this rating with a $\frac{3}{4}$ " coat. Fire-Shield® plaster goes on in one coat, sticks immediately to clean steel decks, and dries (without fissuring) with a bond stronger than the material itself.

See how this remarkable fireproofing plaster can cut costs on *your* next job. Ask your Gold Bond® Representative, or write direct to Dept. AF-460 and we'll send free samples and technical literature.

NATIONAL GYPSUM COMPANY, BUFFALO 13, NEW YORK

4-HOUR FIRE PROTECTION—FAST!



Gold Bond
BUILDING PRODUCTS

a step ahead of tomorrow



Marble

*Adds
Excitement
To Good
Design*

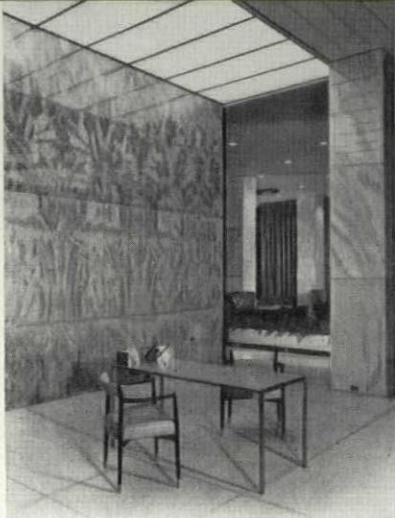

The beauty of American marbles is becoming increasingly apparent to Architects and Decorators who find their clear, quiet patterns highly adaptable to today's simplified decor. In this case a cool pearl gray on columns, screens and wall relieves the movement in the background areas.

Judicious combinations of American and foreign marbles—both finished in this country, where equipment and skills are now the best in the world—enlarge the designer's palette beyond anything known even a quarter century ago. Today, there are over 200 American and foreign marbles available to satisfy the artistic and practical needs of Architect, Decorator or Building Owner.

NEW YORK TRUST COMPANY
640 MADISON AVE. NEW YORK, NEW YORK

Architects: Halsey, McCormick & Helmer



**MARBLE INSTITUTE
OF AMERICA, INC.**
32 SOUTH FIFTH AVENUE
MOUNT VERNON, NEW YORK

Steelcase 76" x 38" desk with hand-rubbed walnut top, matching credenza and four chairs, about \$1,500.



A
wonderful
place
to work!

■ The new executive office — pleasant, comfortable, efficient — created by a unique partnership in ideas between Steelcase and the architect. We maintain a well-staffed architectural consulting service to work with architects and consulting engineers. Full-color brochure on request. Address Dept. A, Steelcase Inc., Grand Rapids, Michigan; Canadian Steelcase Co., Ltd., Don Mills, Ontario.

STEELCASE INC

A continuing review of international building

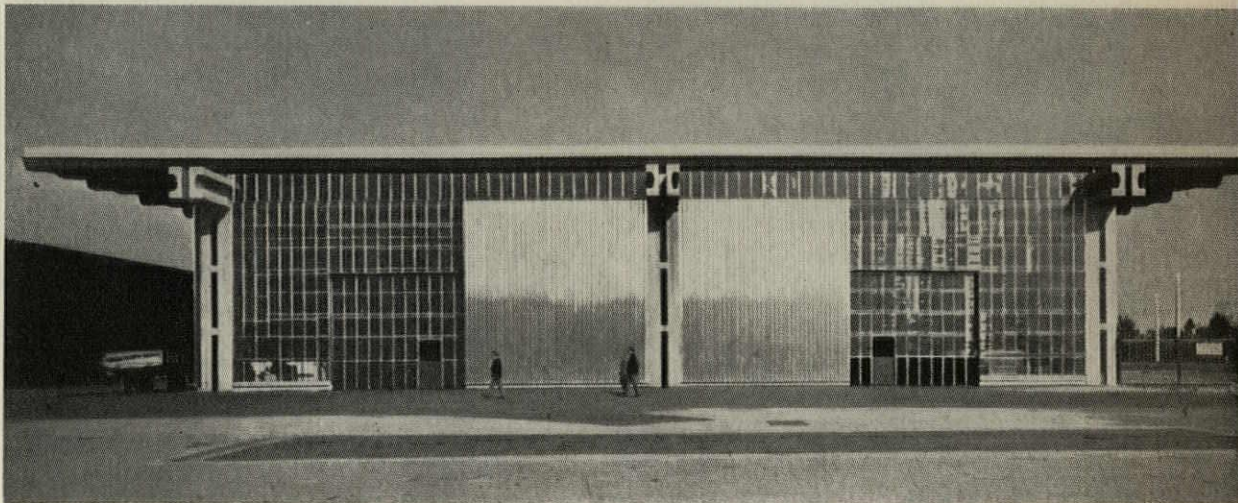

PHOTOS: COURTESY "DOMUS"

MONUMENT IN PADUA

This broad-roofed hardware shed near Padua indicates, among other things, that the warehouse as a building type need not be assigned to architecture's back yard. It also in-

dicates the roof strength that can be achieved by using steel pipes to span a heroically proportioned concrete frame. On the warehouse's monumental structural system Architects

Angelo Mangiarotti and Bruno Morassutti have hung walls of glass and corrugated aluminum. Light is brought into the building by vertical shafts in the horizontal pipe beams.

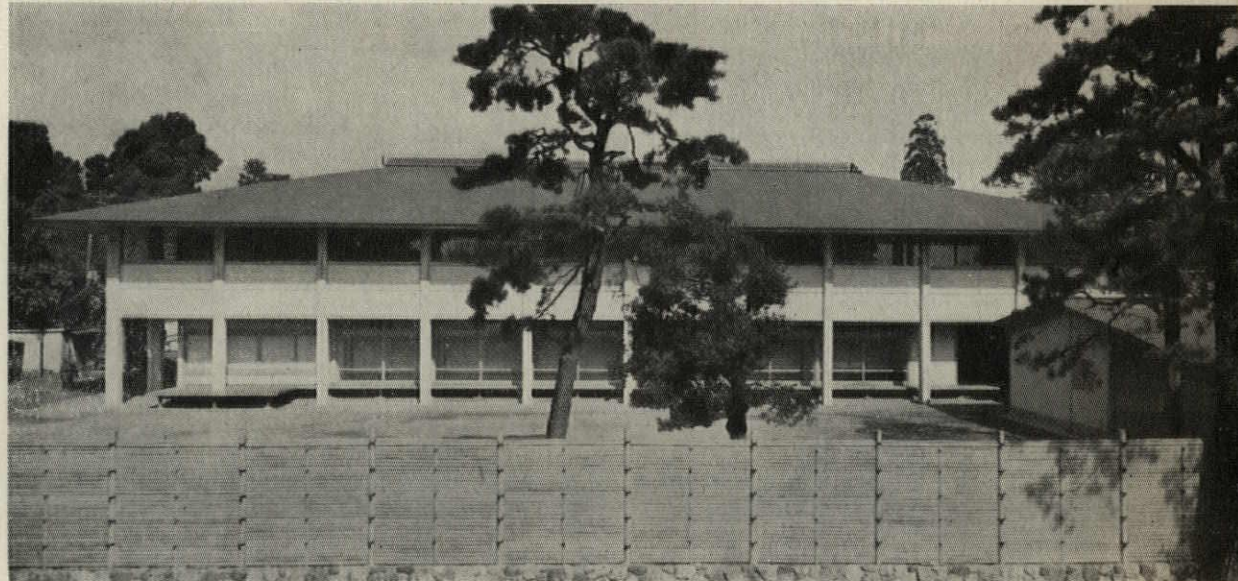
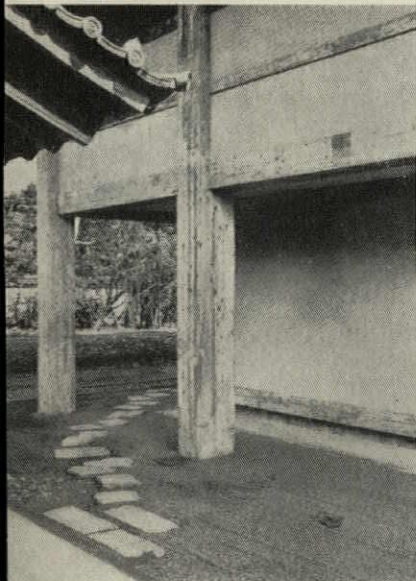

PHOTOS: COURTESY "KOKUSAI-KENTIKU"

TEMPLE IN KYOTO

In Kyoto, Japan's ancient temple city, Architect Togo Murano designed and directed construction of this new temple that is a fascinating lesson in Japanese continuity. Both the simplicity of the concrete structure (photo left, above) and the careful crafting of the

loggia platforms (photo left, below) could be attributed to either modern or traditional styles. The fact that the styles are combined to give interior and exterior spaces of timeless peace is a measure of the continuing strength of Japanese architecture.

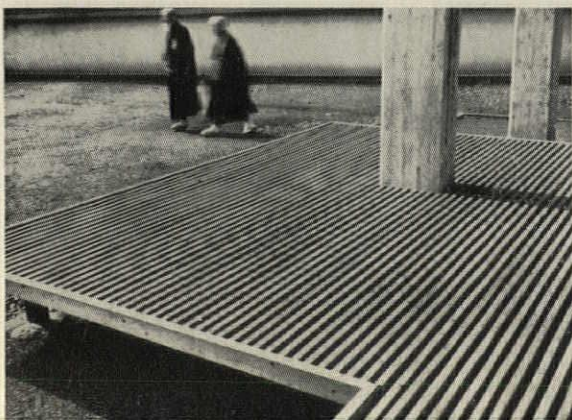



C. E. KIDDER SMITH

HEADQUARTERS IN MILAN

Long awaited as the richest yield from Italy's mine of architectural and engineering talents, the Pirelli building in downtown Milan (above) is now being critically assayed. When first published, the original form that Architect Gio Ponti gave to the building seemed a pure expression of Pier Luigi Nervi's elegant structural system (see model photo, at right). The four massive, hollow column pairs that tapered upward from their deep bases, carrying service

utilities with them, could be appreciated through the model's glass walls, as could the basic division of the building's two halves. In actuality, however, the 36-story building now resembles many another modern corporate headquarters. Its window rows interlined with heavy spandrels have modified the architect's objective to build a "thin, transparent, and light" structure as a new example of what urban architecture might be. The building will be shown more fully later.

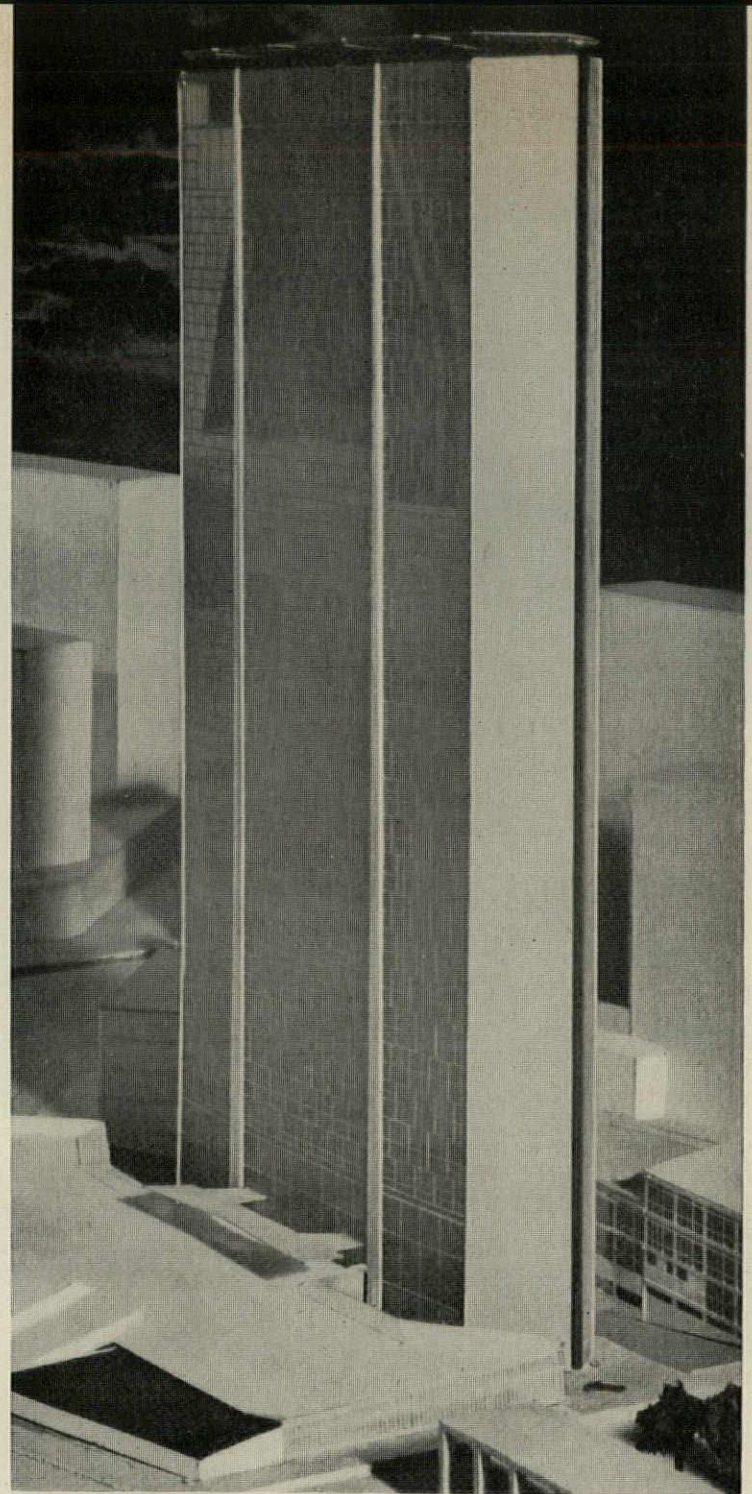

PHOTOS: CHAS. W. MILLER & SON

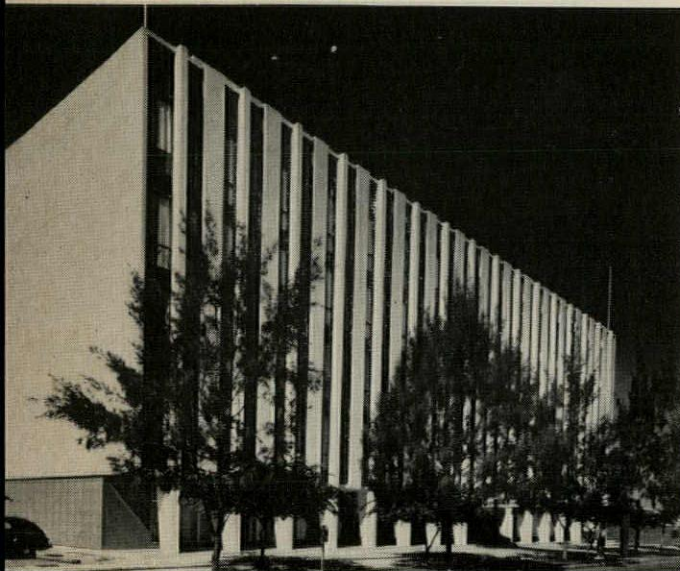

FLEXIBILITY IN MANILA

One of Manila's most admired commercial structures is this office building by Leandro V. Locsin. Built as a speculative venture, the building had to be flexible enough in mechanical and structural plan to be suitable for the needs of any tenant, yet strong enough in basic plan to withstand the rigors of the Philippine climate. Locsin thus brought the columns outside (leaving a 50-foot columnfree interior) and used them as rhythmical fins to shade the windows of the air-conditioned offices. At their bases, the columns taper down, providing a pleasantly sculptural colonnade.

BACK YARDS IN LONDON

In Bethnal Green, a borough of London, the public housing authority is redeveloping former slum areas by means of "cluster blocks," one of which is shown below. The purpose of the cluster block is to break up the usual monolithic apartment house into four relatively small

towers which are so positioned that they admit light, air, and views of the surrounding city into the backyard-like "drying platforms" of the common service core (sketch at bottom). Most of the duplex apartments in the towers have private access to and from the core.



COURTESY "ARCHITECTURAL DESIGN"

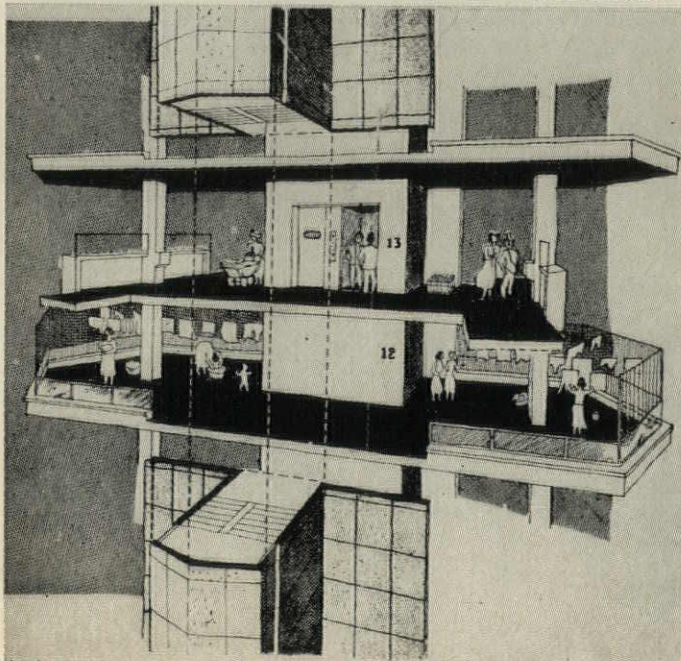

PHOTOS: C. E. KUDEN SMITH



AMENITY IN SWEDEN

At Eskilstuna, a growing city near Stockholm, a busy yet pleasant center has been developed that combines residential units with commercial and cultural facilities. Focal point of the Fröslunda Center is the 13-story apartment tower, which is flanked by plazas and wings of shops and restaurants. At the end of one wing is the movie theater (at left

in top photo) which doubles as an auditorium for the school in back of it. Architects J. Höjer and S. Ljungqvist have filled the main plaza between the tower and the facing garden apartments (photo, above) with enough fountains, sculpture, and well-designed street furniture to satisfy the demands of the most ardent civic humanist. END

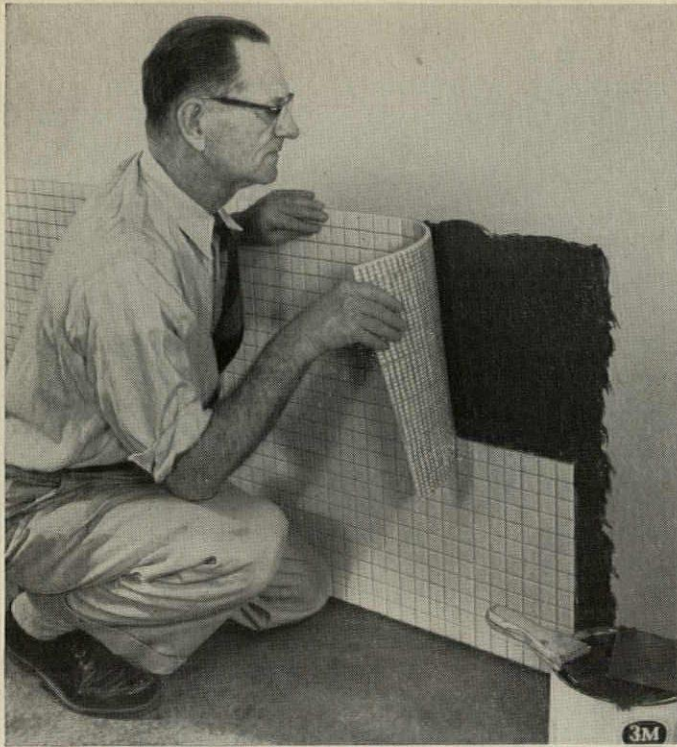

Better handling quality is one reason Perma-Bak cuts costs. Sheets go into place quickly, easily.



With Perma-Bak, the tile setter can see what he is doing. Chance of error is greatly reduced.

NEW **PERMA-BAK**^{*}

MESH-MOUNTED TILE

for Ceramic Mosaics

Reduces Installation Costs

American Olean Perma-Bak tile is a development of special interest to architects—offering as it does substantial savings on unglazed tile installations, especially on long corridors and in large areas.

In some instances, tile contractors have reported labor savings of more than 50% on such jobs.

Perma-Bak can be used to advantage with any accepted setting method—conventional mortar, mastic or the new thin-set mortars. It is available in full-size sheets in both the 1 $\frac{9}{16}$ "- $\frac{3}{4}$ " and the 2 $\frac{3}{16}$ "-1 $\frac{1}{16}$ " series. Plan to use it on your next job.

1. **It goes up fast!** Tile contractors report very substantial labor savings in large areas.

2. **It goes up clean!** No paper or paste to remove. Adhesive doesn't bleed through joints. Grouting is easier.

3. **It goes up right!** Pattern is visible all the time—reduces chances of error on the job.

4. **It goes up smoother!** When set with adhesives, Perma-Bak cushions underbed irregularities—results in smoother surfaces.

CERAMIC TILE
**American
 Olean**

*Trademark
 Licensed under U.S. Pat. No. 2,887,867

AMERICAN OLEAN TILE COMPANY • UNGLAZED TILE FACTORY AT OLEAN, N.Y. • EXECUTIVE OFFICES AT LANSDALE, PENNA. • A SUBSIDIARY OF NATIONAL GYPSUM COMPANY

There can be no compromise here*

On galvanized metal surfaces —
be sure of lasting performance with
Rust-Oleum GALVINOLEUM® Coatings

Galvanized metal surfaces present a special problem—"getting a coating that will really stick, to eliminate paint peeling headaches." Rust-Oleum Galvinoleum is that coating—it can be applied directly over *brand new* galvanized metal *without etching, without weathering, without waiting*—and it lasts and lasts! It is available in four attractive colors—red, gray, green, and metallic. Specify Rust-Oleum Galvinoleum coatings for galvanized buildings, metal gutters, downspouts, roofs, siding, vents, etc. Would you like a guide to lasting performance on galvanized metal surfaces? Write for your free copy of the new 30-page Rust-Oleum Architectural Catalog. Just attach the coupon to your letterhead and we'll send it promptly.



SEE OUR
CATALOG IN
SWEET'S
OR WRITE FOR COPY

RUST-OLEUM®



There is only one Rust-Oleum.
It is distinctive as your own fingerprint.
A matter of excellence.

STOPS RUST!

RUST-OLEUM CORPORATION
2551 Oakton Street
Evanston, Illinois

New 30-page Rust-Oleum
Architectural Specifications
Catalog. Features actual
color charts. Clip coupon to
your letterhead for your free
copy of Form No. 259-A.



Your nearby Rust-Oleum Industrial Distributor maintains complete stocks for your convenience.



NEW *3-Wire*

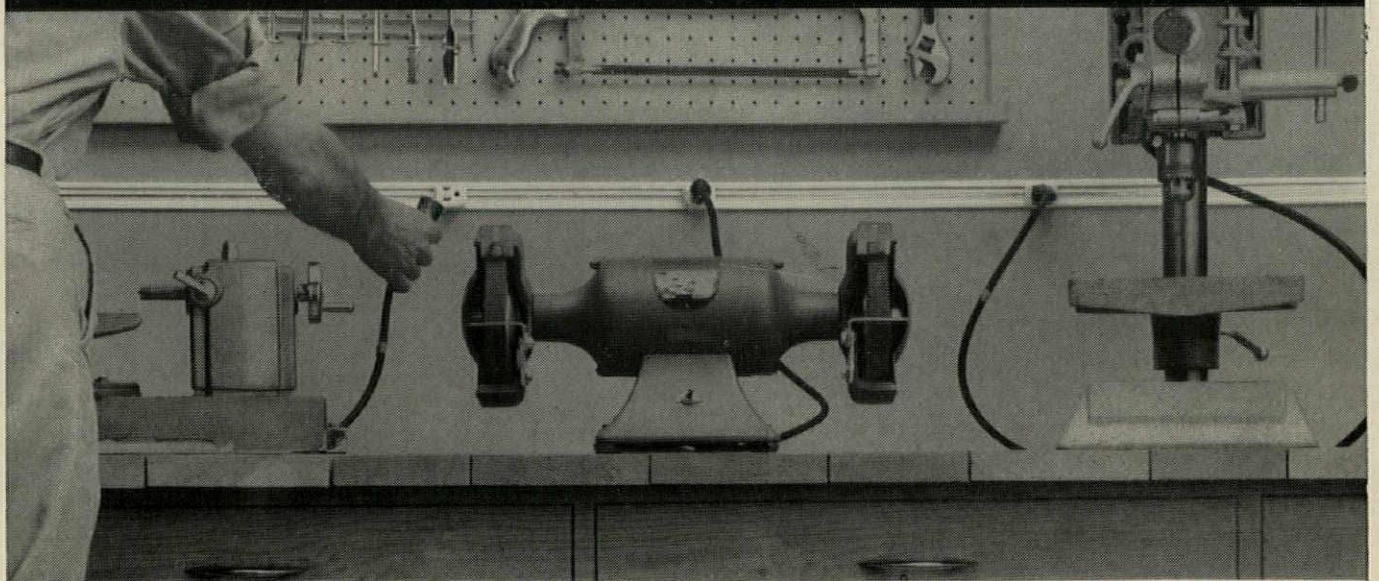
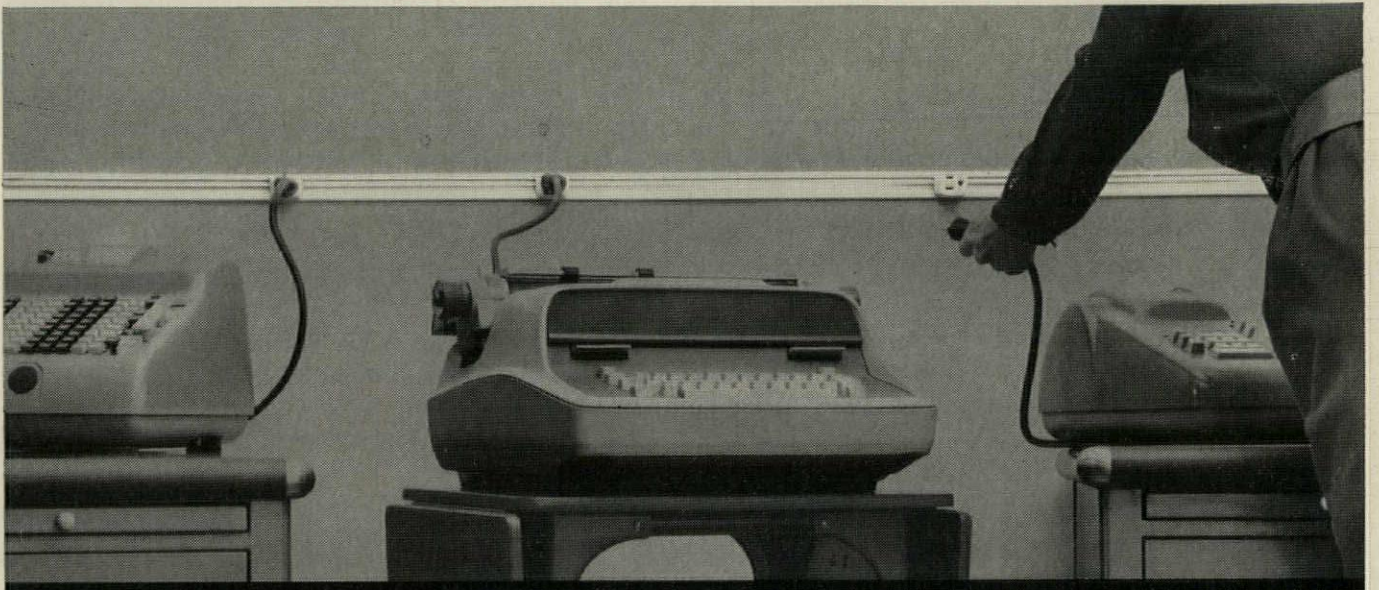

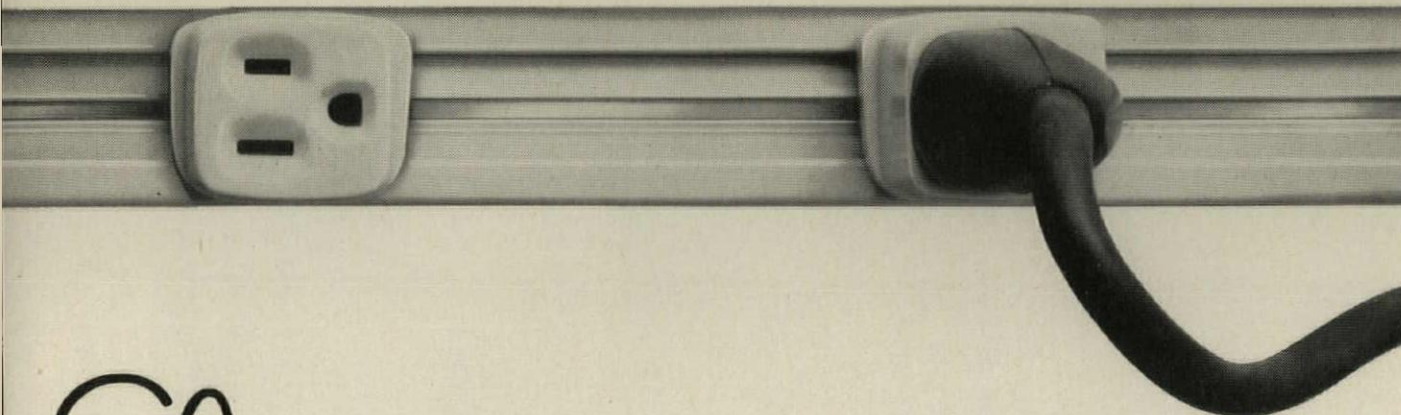

Electrostrip

PATENTED [®]

MEETS THE ELECTRICAL CODE REQUIREMENTS FOR EQUIPMENT GROUNDING

Outlets twist into place anywhere along the strip . . . and each outlet has a grounding contact connected to the equipment grounding conductor.

New 3-Wire Electrostrip eliminates outlet planning, and permits adding or moving equipment and machines at a moment's notice. You can install 3-Wire Electrostrip in a hurry on any surface . . . ready to deliver power . . . without wire-pulling or breaking into plaster.

3-Wire Electrostrip is ideal for new buildings, and for modernizing old ones . . . offices, showrooms, shops, homes, garages, factories. It is UL listed. See your Bulldog distributor. He has 3-Wire Electrostrip in stock in handy 100-foot and 250-foot coils, and a complete selection of fittings (blister-packaged) for any type of installation.

Bulldog Electric Products Division, I-T-E Circuit Breaker Co., Box 177, Detroit 32, Mich. In Canada: 80 Clayson Rd., Toronto 15, Ont. Export Division: 13 E. 40th St., New York 16, N.Y.



BULLDOG ELECTRIC PRODUCTS DIVISION
I-T-E CIRCUIT BREAKER COMPANY

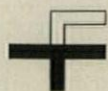

FOLLANSBEE STEEL CORPORATION

Follansbee, West Virginia

As Frank Lloyd Wright once remarked, "Because of its inherent adaptability . . . Follansbee Terne permits the visible roof area to become a significant part of structural design." The recently completed Fasbender Clinic at Hastings, Minnesota—one of his last major projects—dramatically confirms this statement. Here COLOR ● and FORM ▼ unite in a singular felicity of expression, underlined by the FUNCTIONAL □ integrity of the material itself.

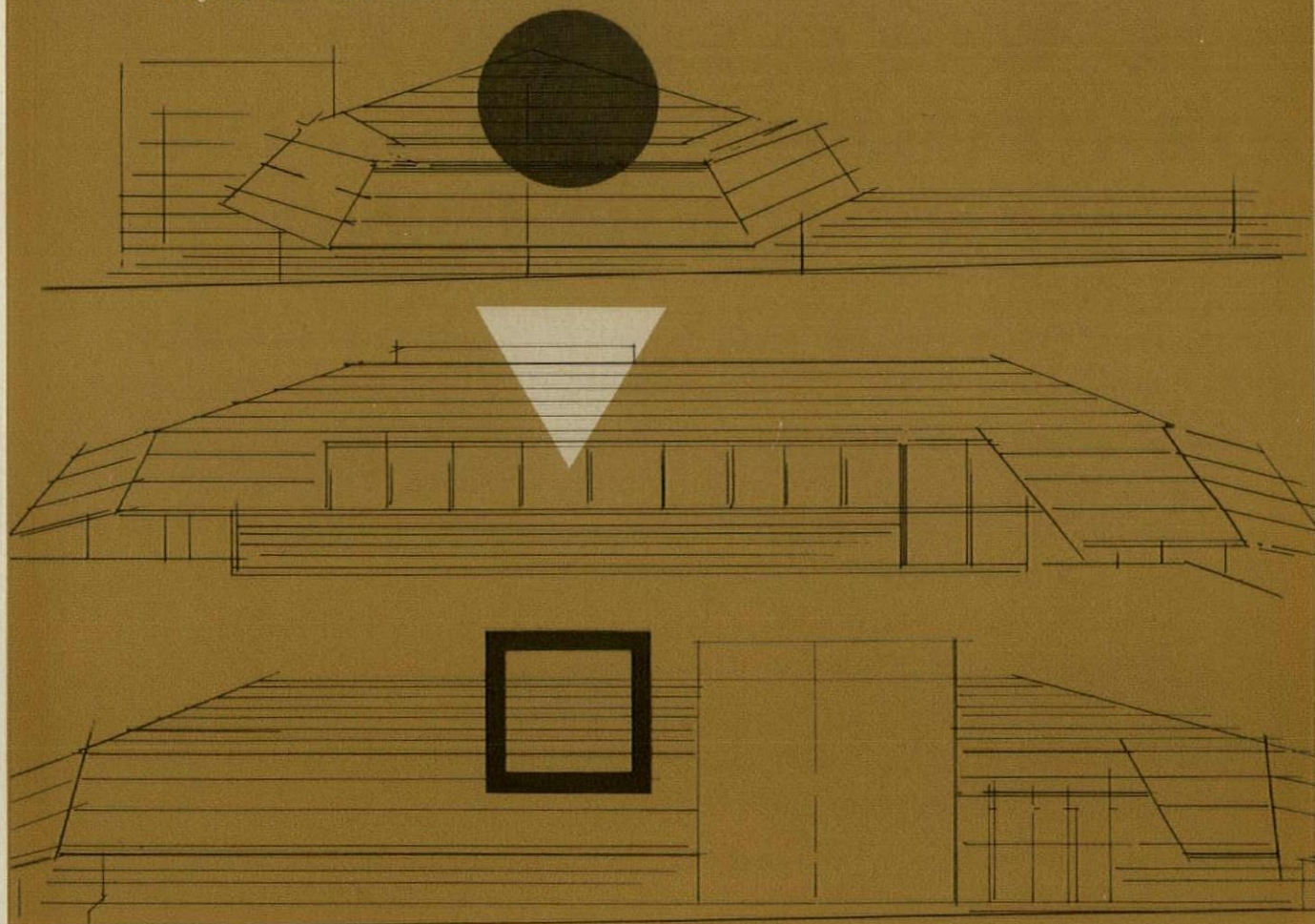

Follansbee is the world's pioneer producer of seamless terne roofing

architects prefer

Roddis doors

2.1
to 1



Recently an independent research organization asked architects: "What brand of flush veneered doors is your first choice preference?" More than twice as many chose Roddis than the next leading brand! Why this great vote of confidence?

These architects know the Roddis name represents a standard of quality and craftsmanship unmatched in the industry. A standard maintained through more than 60 years of manufacturing and design leadership.

Today, more and more architects are specifying Roddis

Doors. In the nation's hospitals for example. Administrators and building committees are vitally concerned that their new hospitals be built of quality products for greatest long-run economy. They insist on doors that will assure proper function, low maintenance and safety, for decades to come.

Roddis now offers the most complete wood door line wholly designed and produced by a single manufacturer. May we send you our latest brochure? Write to:

RODDIS PLYWOOD CORPORATION, Marshfield, Wisconsin

Roddis THE MOST RESPECTED NAME IN DOORS

TRANE ANNOUNCES...

all-new Unit Ventilators with
space-saving design...now
available with air conditioning!

*Units have modern, "built-in" appearance, save
classroom space, meet all climate requirements*

When a group of school architects saw the first models of these new TRANE Unit Ventilators, they said, "Most advanced design in the industry... best-looking, most compact units..."

These modern TRANE Unit Ventilators are more compact than any others. They save space along the wall, can provide a wider aisle. Attractively styled, TRANE Unit Ventilators complement modern school design and decor. Matching trim blends the components together to form a single, continuous unit. The top surface is covered with a patterned hard-top ma-

terial that enhances appearance, resists wear.

And now the TRANE Unit Ventilator system is available with complete, year-around air conditioning. Chilled water source for air conditioning may be included when the system is installed—or easily added later. The same space-saving cabinet is used for all types of systems: hot water, steam, chilled water or electric heating.

For complete facts on the new TRANE Unit Ventilators, call your nearby TRANE Sales Office; or write TRANE, La Crosse, Wisconsin.

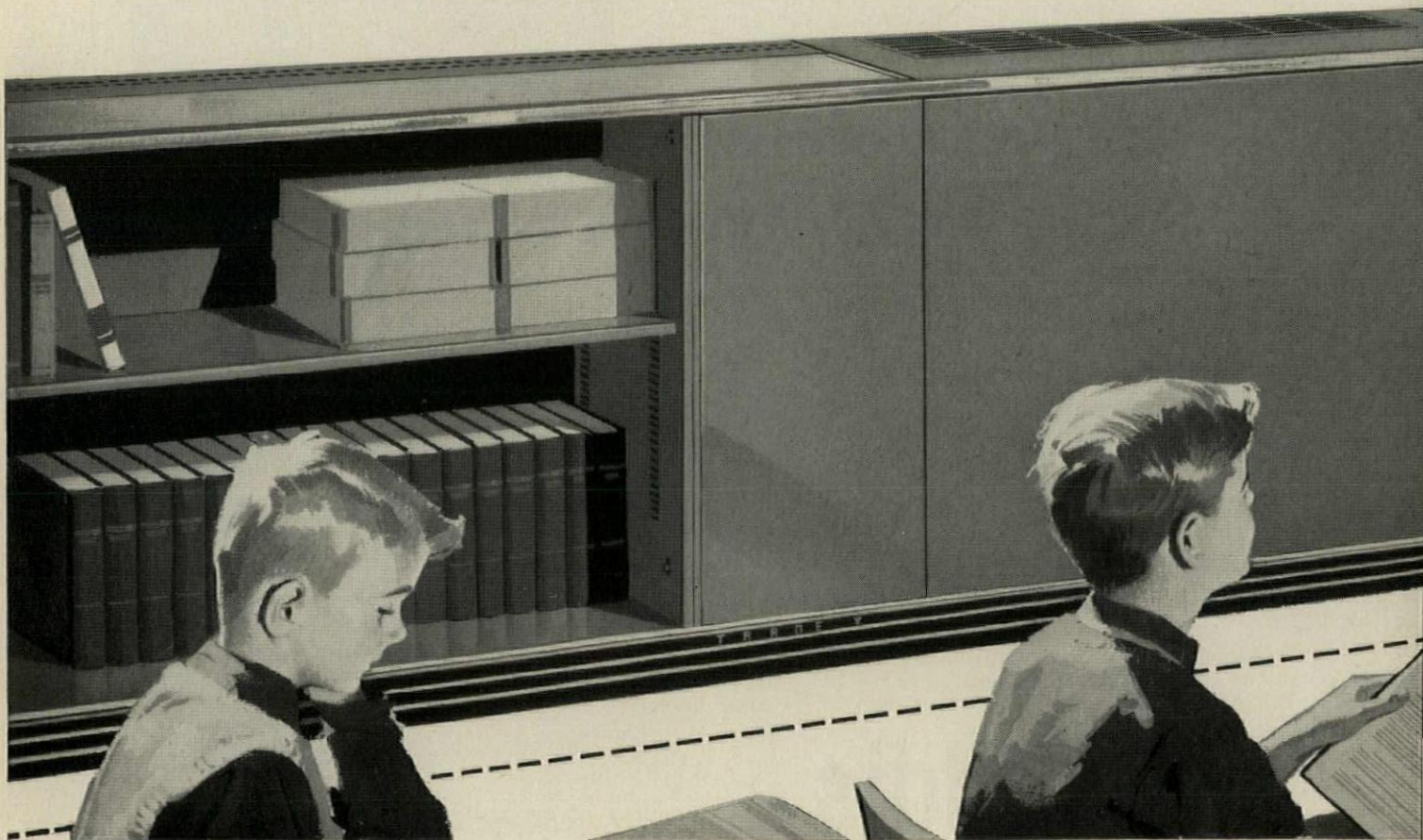

**TRANE Unit Ventilators
provide these
important features
for the
modern classroom**

- **Space-saving design.** Most compact units in the industry provide more usable classroom space. All 28" and 32" high conventional units are 11 $\frac{5}{8}$ " deep. 28" high *Kinetic Barrier* air conditioning units are 14 $\frac{7}{8}$ " deep.
- **Modern appearance.** Matching trim blends components together to form a continuous unit. Attractive shelving provides built-in storage and cabinet space.
- **Versatility.** TRANE Unit Ventilators provide just the type of system needed. Five basic types to meet the requirements of any school, any climate. Same space-saving cabinet used for all types.
- **Exclusive *Kinetic Barrier* Action.** Provides continuous powered ventilation and heating or cooling from room-wide outlets. Eliminates window downdrafts, sleepy corners . . . provides an ideal climate for learning all day long!

For any air condition, turn to

TRANE

MANUFACTURING ENGINEERS OF AIR
CONDITIONING, HEATING AND VENTILATING
EQUIPMENT FOR THE MODERN SCHOOL

THE TRANE COMPANY, LA CROSSE, WIS. • SCRANTON MFG. DIV., SCRANTON, PA. • CLARKSVILLE MFG. DIV., CLARKSVILLE, TENN. • TRANE COMPANY OF CANADA, LIMITED TORONTO • 100 U.S. AND 15 CANADIAN OFFICES



**Trane Unit Ventilators
save valuable floor space**

The new TRANE Unit Ventilator is 21% thinner than other makes of heating units . . . 29% thinner than other makes of heating-air conditioning units. (Other makes of units are as much as 16 $\frac{3}{8}$ " deep.) Same space-saving cabinet design is used for all systems—water, steam, electricity.



Strong, durable, lower in cost

You can now specify windows of sturdy, lasting stainless steel—at a cost much lower than you may think. Reason? Manufacturers now *roll-form* windows from Allegheny Stainless and pass the fabrication economies on to you.

In actual bidding recently, the price of roll-formed Allegheny Stainless windows averaged only about 10% higher than another non-stainless metal.

Vital to architecture, durability and compatibility are inherent in Allegheny Stainless. It never requires chemical films for surface protection, and virtually cleans itself with normal rainfall. Because of an amazing resistance to corro-

WSW 7298

sive atmospheres, the brightness and freedom-from-pitting of Allegheny Stainless are recorded history; yet different patterns, textures and colors make news each day.

Stainless steel windows—of all-welded design and tubular construction—are available in Allegheny Stainless Types 202 and 302.

Include Allegheny Stainless in your design-thinking now. Learn how you can get the quality of stainless steel windows for much less than you think. For additional facts, and manufacturers' names, write to *Allegheny Ludlum Steel Corporation, Oliver Bldg., Pittsburgh 22, Pa. Dept. B-28.*



ALLEGHENY LUDLUM

Export distribution: AIRCO INTERNATIONAL

EVERY FORM OF STAINLESS . . . EVERY HELP IN USING IT

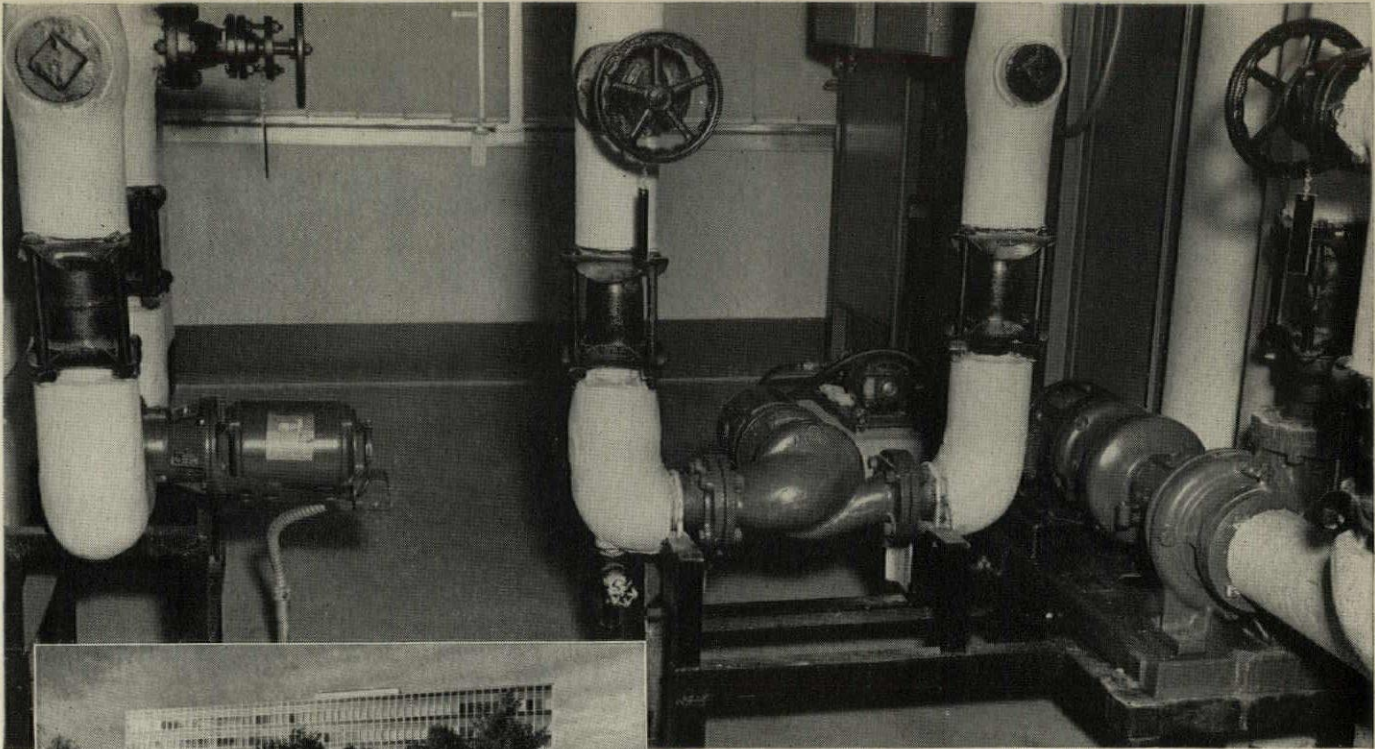

Washington Water Power Building, Spokane, Wash. and one of the pumping stations.

Architects: Kenneth W. Brooks, A.I.A.
 Bruce M. Walker, A.I.A.
 Mechanical Engineer: Wood & Landerholm
 J. Donald Kroeker & Associates—Consultant
 Mechanical Contractors: Warren, Little & Lund, Inc.

WORLD'S THIRD LARGEST HEAT PUMP INSTALLATION EQUIPPED WITH **B&G® PUMPS**

In this modern building, the third largest heat pump installation in the world provides 815 tons of refrigeration and 9,000,000 BTU for heating. The heat pump draws 1600 GPM from a deep well with the water being discharged to the river in winter and used for irrigation in the summer.

The heating and cooling system is a dual duct, high velocity system, with a separate zone and pumping station on each floor. Five B&G Universal pumps and 21 B&G Boosters provide the necessary circulating equipment.

The system employs the Primary and Secondary Method of Pumping developed by B&G engineers. This method materially reduces pump horsepower required and provides close temperature control, more comfort, lower operating and installation costs.

Send for free booklet on B&G System of Primary and Secondary Pumping.

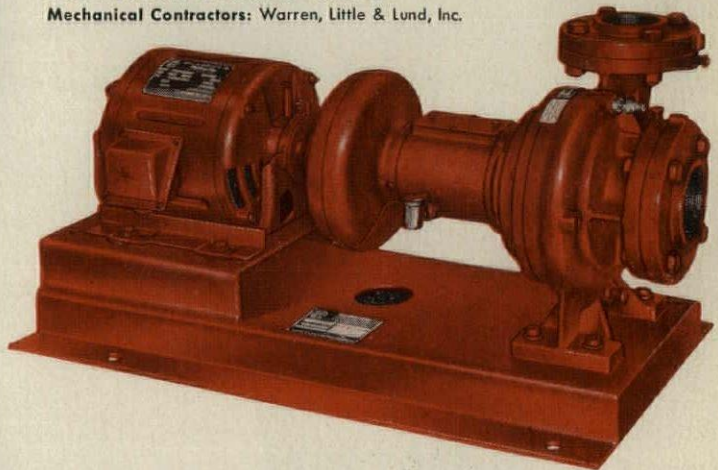

B&G Universal and Booster Pumps are specially designed and built for systems using water for heating and cooling. They are distinguished by quiet, vibrationless operation and long failure-proof operation. They can be installed without flexible connectors or noise dampeners of any kind.



BELL & GOSSETT
 COMPANY
 Dept. GD-62, Morton Grove, Ill.

Canadian Licensee: S.A. Armstrong, Ltd., 1400 O'Connor Drive, Toronto 16, Ontario

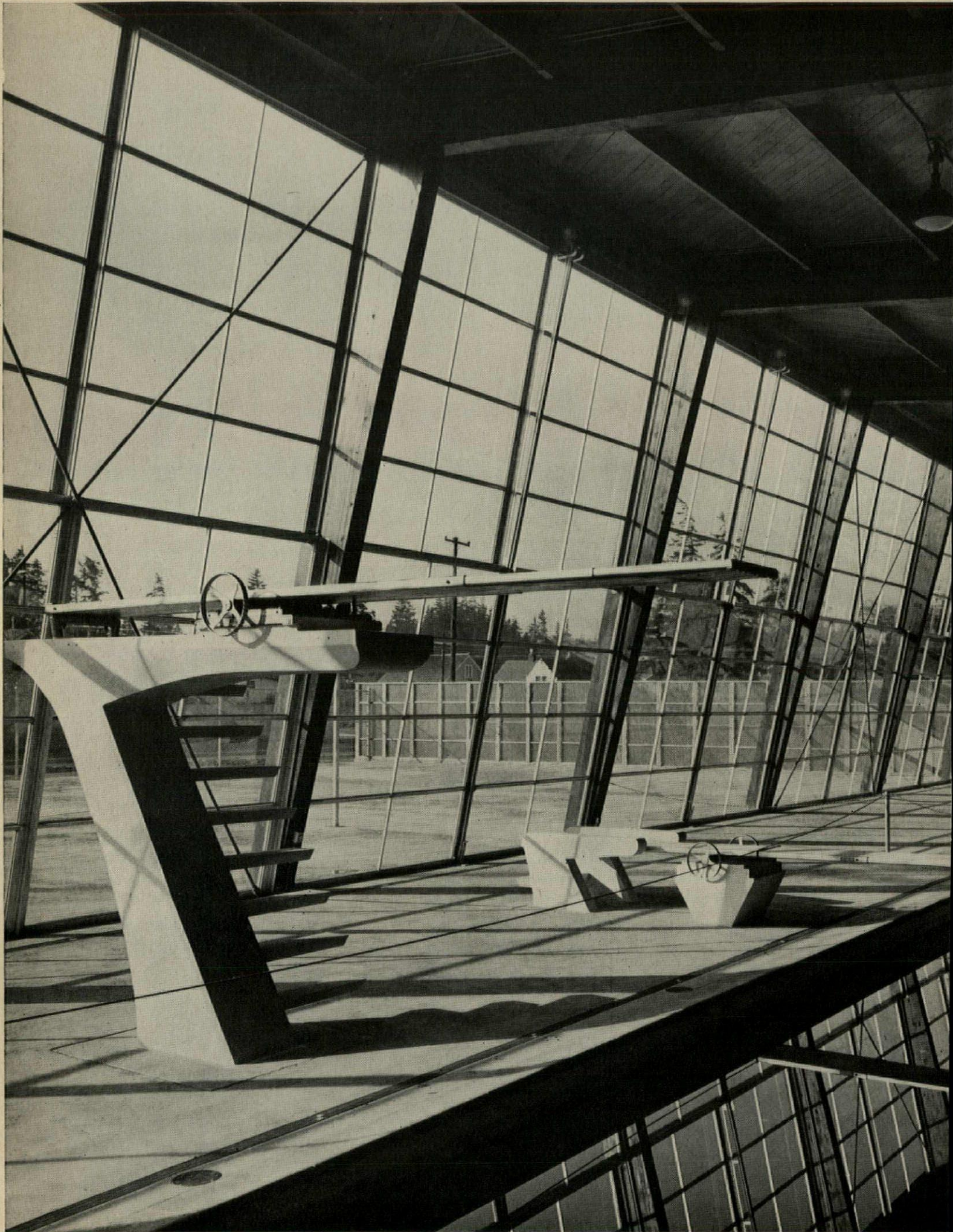

"OVERHEAD DOOR" opens a new door to climate control

Now doors adapt any building to weather, temperature changes

Now the "OVERHEAD DOOR" offers you new ideas in climate control. Through unique, imaginative applications you can now design structures that literally *adapt* to changing seasons, changing temperatures.

One new idea is the movable wall—banks of "OVERHEAD DOORS" that make the whole wall open, close . . . quickly, silently. To a basically outdoor structure, they let you add indoor protection. To a basically indoor structure, they let you add measured amounts of sun and fresh air.

The dramatic swimming pool shown at left is an example. Oregon architect Gordon Trapp utilized banks of glass-paned aluminum "OVERHEAD DOORS" to bring climate control to this indoor-outdoor swimming pool. They open the pool to warm, fair weather,

tightly close it to cold, foul weather—flood it with light all year 'round.

Many other new ideas in climate control have been developed and tested by Overhead Door Corporation engineers—ideas that are a result of this company's 39 years of experience in the garage door field. Some of these ideas may be of value to you.

Get detailed information from your local distributor (see "OVERHEAD DOOR" in the white pages) for an application you may now be planning, or write to Overhead Door Corporation, *General Office*: Hartford City, Indiana—*Manufacturing Distributors*: Cortland, N.Y.; Hillside, N.J.; Lewistown, Pa.; Nashua, N.H.—*Manufacturing Divisions*: Dallas, Tex.; Portland, Ore.—*In Canada*: Oakville, Ontario.

To solve many climate control problems—



Ventilating doors—Protection from winter weather, screened ventilation for summer comfort are both provided with a double-track "OVERHEAD DOOR." This arrangement actually holds two doors—one with screen panels (A), one with wood and glass panels (B).



Weather-lock—Double rows of doors protect shipping areas. An inside row (A) of "OVERHEAD DOORS" is opened after the outer doors (B) have been closed. Trucks or railroad cars are loaded in a protected area, without excessive loss of heated or cooled air.



Movable store front—Stores and markets also utilize movable walls for climate control to stimulate customer traffic. "OVERHEAD DOORS" open the whole store front—attract customers with a store-wide display. At night and in bad weather, doors secure tightly.



the original upward-acting sectional door, made only by

OVERHEAD DOOR CORPORATION

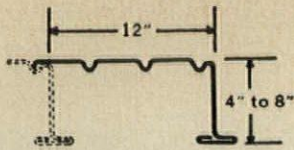

T-STEEL — New! Galvanized. For clear spans to 32'0". Adaptable to acoustical and flush, luminous treatments. Provides superior diaphragm to resist seismic and wind loads.

Ceiling Treatments with T-Steel Deck

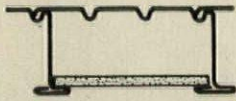

Standard Tile or Board

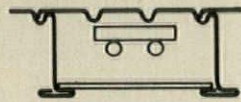

Light Diffuser

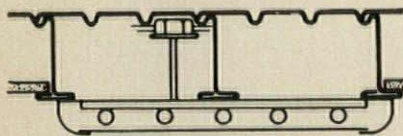

Surface-mounted Fixture

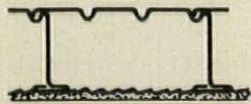

Lath-and-Plaster Fireproofing

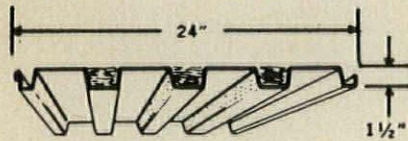

TYPE B ACOUSTIDECK — For purlin spacings to 10'. Uses minimum of 1" rigid insulation board.

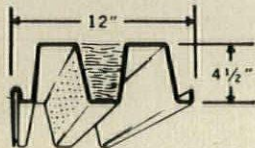

TYPE C ACOUSTIDECK — For purlin spacings to 24'. Uses minimum of 1 1/2" rigid insulation board.



ACOUSTIDECK



INLAND coordinated roof

Complete structural systems permit a range of ceiling, lighting, and acoustical treatments within budget limitations

Acoustideck serves as a combination steel roof deck and acoustical ceiling having a Noise Reduction Coefficient of .70. It is especially practical over gymnasiums and other areas where it is important to have acoustical treatment not easily damaged.

Panels are erected fast in any weather that a man can work. Since the panels are Bond-erized, then covered with a baked-enamel prime finish, field-painting costs can be cut in half because only one finish coat is required normally. The fluted underside is left exposed as an attractive ceiling.



T-STEEL
ROOF DECK

systems save school building dollars

New T-Steel Roof Deck allows you design freedom in covering classrooms of 26' to 32' spans. You can specify various types of acoustical tile — provide a flush, luminous ceiling — or leave the underside of T-Steel exposed and paint it.

T-Steel deck provides a superior diaphragm to resist seismic and wind thrusts — proved by full-scale shear tests conducted by independent engineering firms.

Write for catalogs 240, 241 and 246 — or see Sweet's sections 2c/Inl and 11a/In for full information on Acoustideck and T-Steel. Inland Steel Products Company has a force of trained sales engineers capable of giving you the benefit of diversified experience on specific problems. Write or call your nearest Inland office.

member of the



ENGINEERED PRODUCTS DIVISION

**INLAND STEEL
PRODUCTS COMPANY**

Dept. D, 4031 West Burnham Street
Milwaukee 1, Wisconsin

EP-6

DENVER, DETROIT, HOUSTON, KANSAS CITY, LOS ANGELES, MILWAUKEE, MINNEAPOLIS, NEW ORLEANS, NEW YORK, ST. LOUIS

(CUPRA/CREST
DESIGN—ALUMINUM)

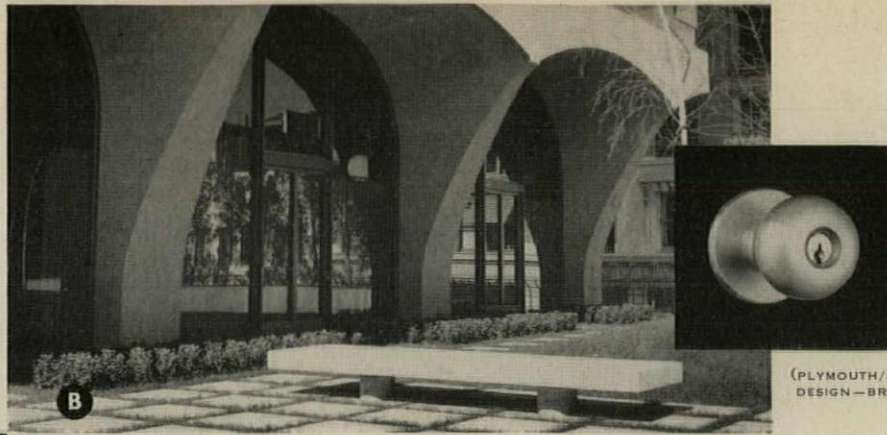

(PLYMOUTH/SATURN
DESIGN—BRONZE)

Designs of Enduring Worth —Locked by SCHLAGE

The glory of a building grows out of a sensitive selection and use of materials by the architect. We at Schlage make it our aim to assist the architect in our special field by placing at his disposal a variety of designs and finishes to suit every style and mood of design.

In the San Francisco-Oakland area, see each of the four important buildings pictured here. All have used Schlage Locks as elements of the whole.

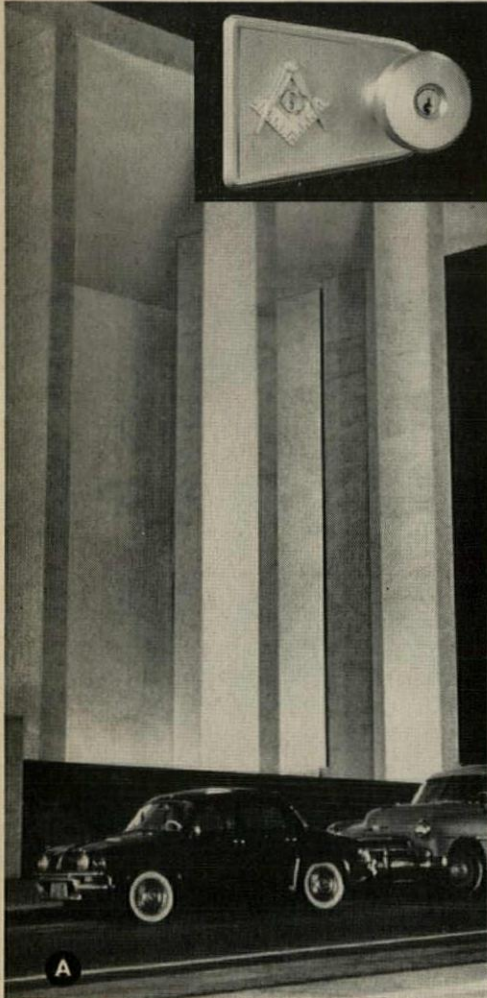

At the AIA Convention . . .
Visit the Schlage Exhibit
California Masonic Memorial Temple
Booths 44-45

(PLYMOUTH/CENTURY
DESIGN—STAINLESS STEEL)

A. California Masonic Memorial Temple, San Francisco
Architect: Albert F. Roller
General Contractor: MacDonald, Young & Nelson, Inc.

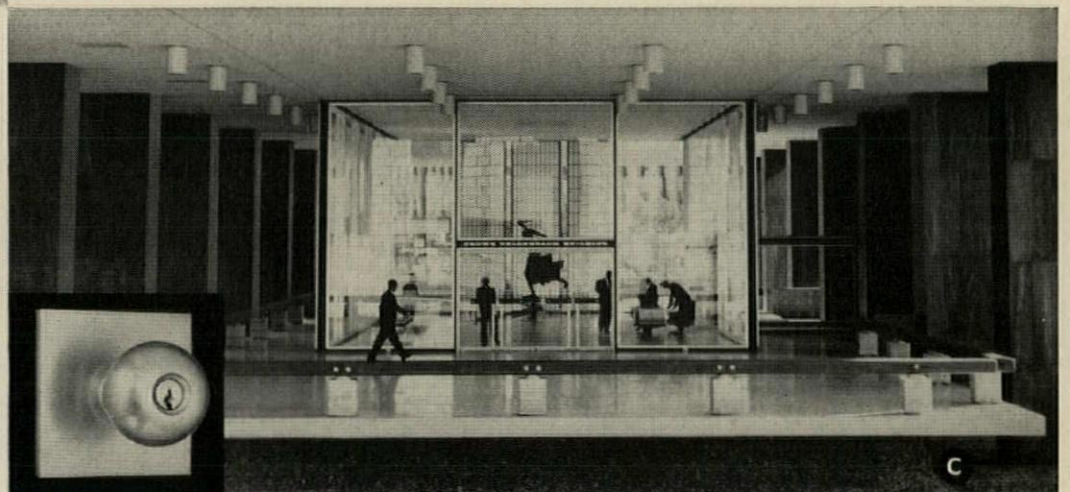



(TULIP DESIGN—ALUMINUM)

® SCHLAGE ©

CYLINDRICAL LOCKS

Schlage Lock Company... San Francisco... Chicago... New York... Vancouver, B. C.

B. John Hancock Western Home Office,
San Francisco
Architect: Skidmore, Owings & Merrill
General Contractor: Cahill Brothers

C. Crown Zellerbach Building, San Francisco
Architect: Hertzka & Knowles; Skidmore, Owings
& Merrill, Associated Architects
General Contractor: Haas & Haynie

D. Kaiser Center Office Building, Oakland
Architect: Welton Becket and Associates
General Contractor: Robert E. McKee General
Contractors, Inc.

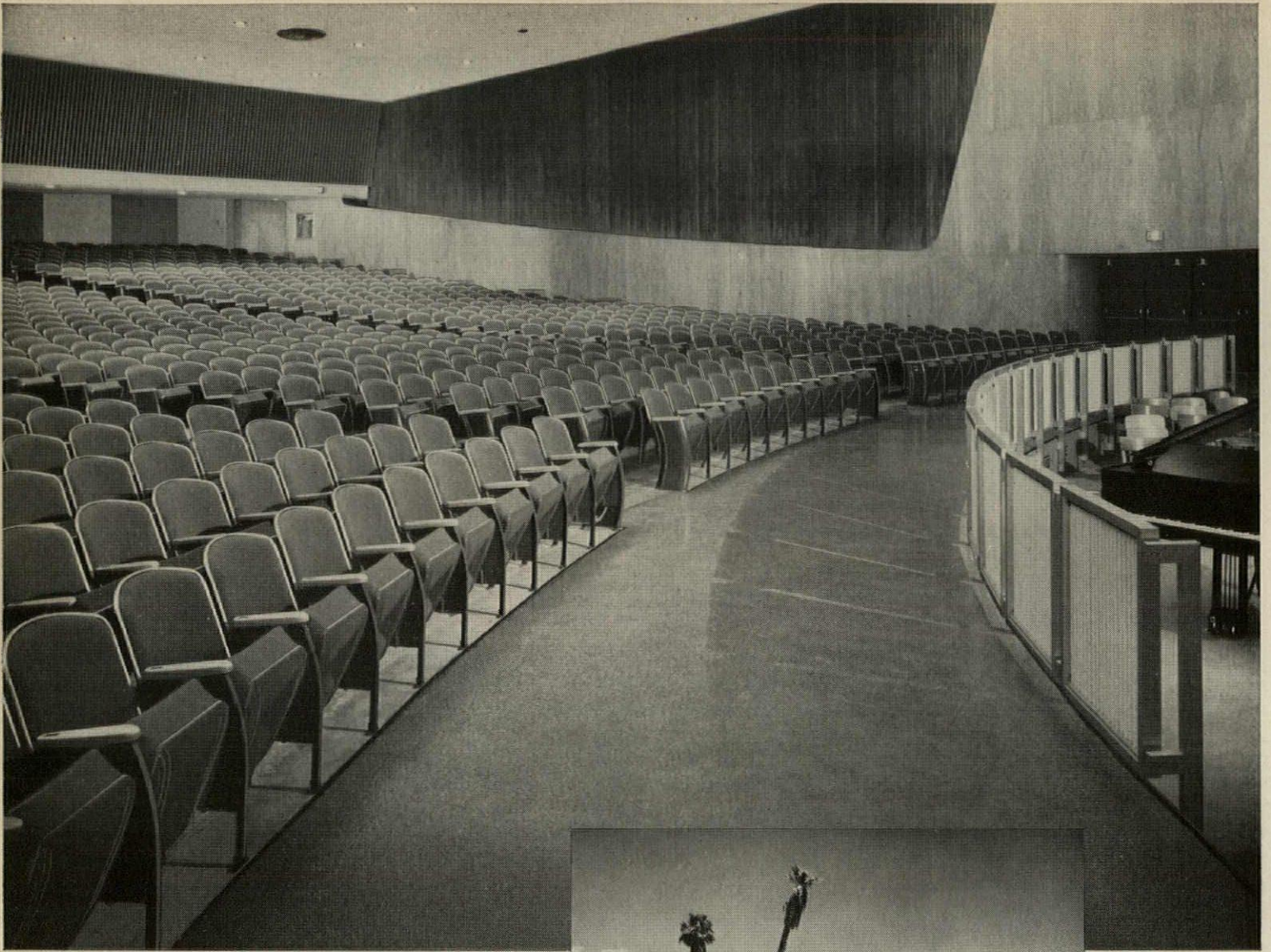

Architects for the Palm Springs High School at Palm Springs, California were Williams & Williams and Clark, Frey & Chambers. Seating arranged through B. F. Shearer Company: Los Angeles, San Francisco, Seattle, Portland.



Lasting comfort greets the audience in The Palm Springs High School Auditorium

Seated with 1100 Heywood-Wakefield TC 616 "Scholastic" Chairs, this new auditorium will continue to offer deep-down comfort through years of minimum maintenance. Lifetime chrome banding around the top and sides protects the red mohair upholstery fabric from damage or soil. Sixteen coil springs of varying gauges and heights provide utmost comfort in the cushion seat, while the full-length steel back protects it in both raised and lowered positions. Priced for initial economy, built for long-run economy, the Scholastic is frequently specified for school auditoriums.

Write for Auditorium and Theatre Seating Catalog

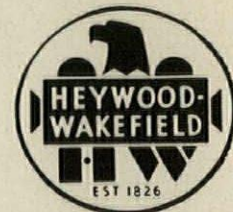

PUBLIC SEATING DIVISION
Menominee, Michigan

AUDITORIUM and THEATRE SEATING
SCHOOL FURNITURE • PORTABLE SEATING
and FOLDING CHAIRS
CONTRACT LINES FOR HOTELS and MOTELS



MUELLER
BRASS CO. [®]

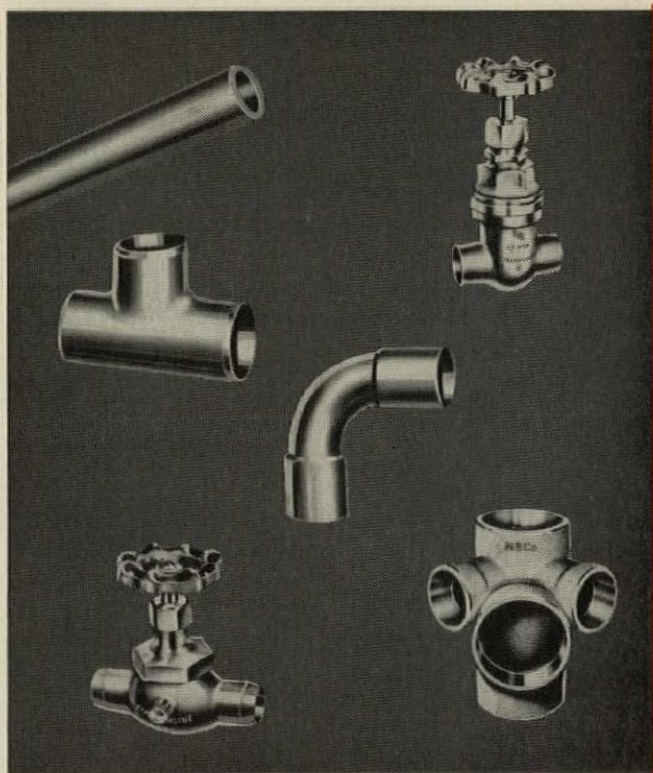

a new symbol
for all these
QUALITY PRODUCTS
for plumbing and
heating from **ONE**
dependable source

This distinctive corporate symbol is a new addition to the American business scene and will be found on the many diversified products made for the plumbing and heating industries by the Mueller Brass Co. of Port Huron, Michigan . . . your one dependable source for such products as Streamline solder-type fittings, copper tube and valves.



MUELLER BRASS CO.
PORT HURON 9, MICHIGAN

ALSO MANUFACTURERS OF: REFRIGERATION VALVES, DRIERS, FITTINGS AND ACCESSORIES • FORMED COPPER TUBES • BRASS AND BRONZE ROD • FORGINGS • SCREW MACHINE PRODUCTS • IMPACT EXTRUSIONS • CASTINGS • ALUMINUM WINDOWS • ALUMINUM SHEET, COIL AND STRIP • POWDERED METAL PARTS • PLASTIC PIPE, CUSTOM EXTRUSIONS AND INJECTION MOLDINGS.

**LEES custom carpet solved
.....
a highly complex problem
for Harrahs Club in Reno**

Problem: to unify three vast casinos full of spacious rooms, stairways and corridors—and still retain a feeling of separate areas

Problem: to satisfy the demand for a unique design in holiday-mood colors that would show no soil under extraordinarily heavy traffic

Problem: to get a 27-foot repeat design when carpet experts consider a 54-inch repeat large

Homer Huntoon, A.I.D., staff decorator for Harrahs, wanted carpeting everybody told him couldn't be made. That is, until he started working with Lees design and product departments. Yes, Mr. Huntoon got his 27-foot repeats in a five-frame all-wool Wilton for a minimum of cross-seaming in traffic lanes.

Each repeat includes plain color, vertical and horizontal stripes in ingenious rearrangements, with black stria to camouflage cigarette burns. A totally new concept for club and hotel design, and one which permits easy small-area replacement without disrupting the pattern.

Even if your problems are simpler than Mr. Huntoon's, you'll agree with him, "Co-operation from Lees was outstanding, their designing most advanced." Now, while you're in the planning stage, write for the name of the Lees commercial specialist nearest you, and for free brochure.

James Lees & Sons Co., Bridgeport, Pa.

those heavenly carpets by *Lees*®



Constructive device . . . congested sites . . . curtains

THE A.I.A. AS A DEVICE

Architect A. Quincy Jones, 1960 president of the Southern California Chapter of the A.I.A., described his concept of the Institute when delivering his inaugural address in January.

There is no *unimportant* architecture. The barn, the tract house, the factory, the warehouse, and the service station are equally as important in our total environment as the museum, the opera house, shopping center, and church. This total responsibility cannot be met by an individual architect when he must face all of today's complexities of practice. The American Institute of Architects through a joint effort by a great number of architects should be a device to make it possible for all of us to spend a larger proportion of our time practicing real architecture.

If I should pose the question: "Should the architect be the best possible business man and subtle design and technical skills?" there is no doubt that the answer would be negative. On the other hand, to the question: "Should the architect be the designer with the technical ability and subtle the business functions of a practice?" most all of you would agree that this would be ideal. I believe that allotting a small portion of each member's time to some constructive function of the Institute would make it possible for all of us to practice architecture as we like to think of the practice of architecture.

If we are going to be architects and truly believe that architecture is an art and that architects and architecture can provide a better environment for people, we must find the device that will make it possible to expend the majority of our energies in architecture as an art. This device, if all of us want it to be, is the American Institute of Architects.

GROPIUS AND GARROWAY

Walter Gropius, chief of the design team that has conceived the 59-story Grand Central City, was recently asked by television's Dave Garroway what justification there was for adding such a gigantic building to Manhattan's most congested area.

Every citizen has the right to use the law as far as he can. Specifically, New York City zoning permits a tower of unlimited height on 25 per cent of the site. So in this case, because it is almost a block, we could build a tower as high as we wanted to. But that, of course, is limited

by practical reasons, because when we have too many elevators—there are already 67 in this building—there is not very much left for office spaces. That keeps it to a reasonable amount.

This location, between Park and Vanderbilt Avenues on 45th Street, is the very best one in the whole region. It is really in the center of everything. One couldn't imagine that we'd take everything down and make a green space there. This is really a spot where a large building belongs. There has been a trend toward Park Avenue during the last ten or 15 years to build one high skyscraper after the other in that region. At present there are six big skyscrapers under construction which will have at least as many people as will go into this building. Of course, there will be some more congestion there as it is now, but—and the *but* I would like to underline—there are a lot of reliefs coming with this building here, particularly for the pedestrian.

Imagine the old hall of Grand Central Station (at far right in model photo below) as the southern or 42nd Street entrance to the new Grand Central City. Everyone now goes through and out to the cramped corner of Vanderbilt Avenue. The existing office building blocks everything going northward toward 45th Street. We will make it so open that people will flow through naturally. So I dare say that we will decongest the area for the pedestrian because there will be a very large hall three stories high all the

continued on page 179



Balfour
rolling doors

deserve your attention



rolling steel service doors
doc-port® rolling steel pier doors
automatic rolling fire doors
pygme® rolling counter doors
rolling steel grilles

Details in Sweet's or write for catalog.

Walter Balfour & Co. Inc.
Brooklyn 22, N. Y.

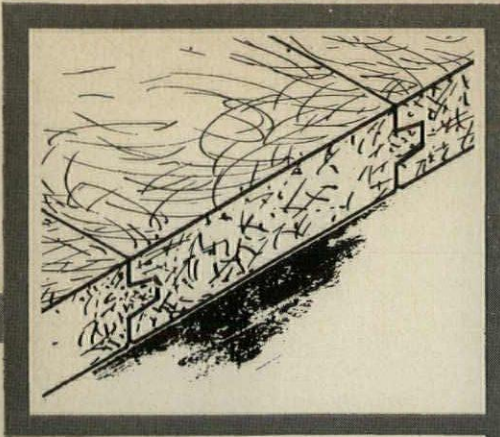

THE INTERLOCKING JOINT

NEW

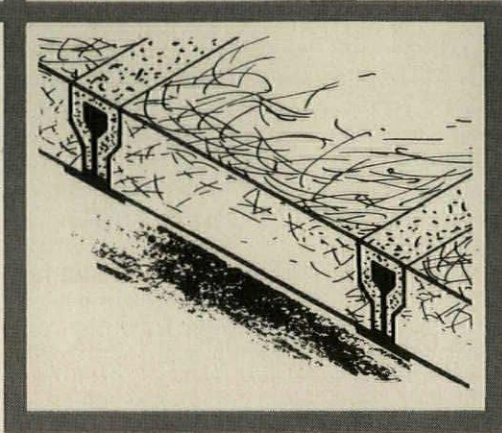

CHAMFERED EDGE

from

FLINTKOTE INSULROCK®

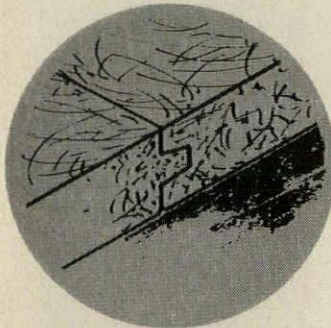

NEW from Insulrock - The Interlocking Joint for joist and beam construction aligns the roof deck for better appearance and greater strength; makes installation easier, faster; improves insulation; distributes loads over broader area; seals joints against run-through.

Available in standard Insulrock sizes at no extra charge.

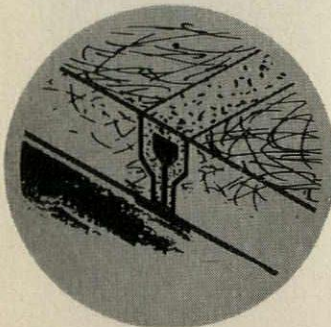

NEW from Insulrock - improved chamfered edges in sub-purlin construction further increase resistance to uplift; provide continuous structural joints that are sealed against run-through; give joints superior strength for long years of trouble-free service.

for better Roof Decks

Insulrock's positive new advantages in roof deck construction further simplify your selection of the best deck on the market. For ultimate beauty and high light reflectance in exposed, acoustical ceilings . . . for portland-cement-bonded strength . . . for all-in-one efficiency and economy . . . the answer is simple: **INSULROCK-FOR BEAUTY THAT STANDS UP THROUGH THE YEARS.**

Specify these newest Insulrock features for even greater satisfaction with **FLINTKOTE INSULROCK Roof Decks**



Manufacturer of
America's Broadest Line
of Building Products

THE FLINTKOTE COMPANY Insulrock Division

Executive Office: New York, N. Y.
General Sales Office: Richmond, Virginia
Plants: North Judson, Indiana; Richmond, Virginia
District Sales Offices: Atlanta, Georgia; Cleveland, Ohio;
Dallas, Texas; East Rutherford, New Jersey; Kansas City,
Missouri; Los Angeles, Calif.

length of the building toward 45th Street. People coming out of the station will go up escalators from the big existing hall and go right straight through to 45th Street and Vanderbilt Avenue.

More difficult, of course, is the problem of traffic congestion. The owner of a building or a group of architects cannot do much about this without the city. In this the city must come in. I will give you one explanation which I think could be done.

Now 45th Street is completely congested by trucks coming out for the post. It is hardly used by pedestrians for anything. We intend to set back the building's front so that we get a pedestrian walk of 35 feet width on 45th Street all along the building, with a large entrance going to this three-story lobby just opposite the New York Central building. And this will be open for the traffic. If we get a bus line going through 45th Street (which doesn't exist now), going westward to the center and to the bus terminal at 8th Avenue, then we would get decongestion in western traffic on 42nd Street.

Another point: a lot of people now coming in the city via Pennsylvania Station go through the shuttle service to Grand Central to board another train. Why should it be that all these people must go through Grand Central Station? We should get a bypass somewhere and this can be done only by the city.

TO THE BARRICADES!

A fairly wild-eyed group of London students who call themselves Anti-Ugly Action has recently been in the British news as a result of marches and demonstrations against buildings of dubious architectural merit. The Royal Institute of British Architects regards all this with quiet horror. Yet the chairman of the A.U.A. was given space for an article about the A.U.A.'s future in "The Architect's Journal."

Perhaps the most interesting thing about Anti-Ugly Action has been its success. In its own terms of attempting to interest the public in architecture it has been effective. In this high-old, philistine-old country the man in the street has heard of Anti-Ugly Action even though he has not heard of the R.I.B.A.—even though he occasionally seems to think that A.U.A. is *against* modern architecture (this calumny has appeared in print a number of times, and highlights just one of the difficulties). There are those who think that to get the public interested would be a dangerous thing, and with them we could not agree less. A genuine and informed interest would be ideal but that cannot be achieved without starting somewhere; and *nothing* could be more dangerous than the present situation, with the public dozing away quietly while the architects and developers heap rubbish on its head.

There are now the first signs that the people of this country are going to start taking an interest in their surroundings, and of course the controversy regarding the development of Piccadilly Circus (photo below) is the key example of this.



PICTORIAL PARADE

A.U.A. was involved, itself, with the M.P.s and is involved in the Inquiry, but it would have had a very tough time trying to persuade the Mother of Parliaments to get alarmed if the public had not been very clearly and vocally concerned.

Why this success, then? Frankly, I have no idea, except that A.U.A. seems to have itself been part of a general awakening of interest in the environment, a growing sense that something valuable was being lost, and that A.U.A. formed a useful focus for feeling. It is not amazing, in an age of Aldermaston marches, that it should have been the young people who formed A.U.A.—in some ways we are both more realistic and more idealistic than our elders. In this context it is interesting that the Action that has been most unfavorably received was our attack on the R.I.B.A. for its multifarious sins. We were called unrealistic and old-fashioned—"look," they said, "at what the R.I.B.A. is doing." And when we went to see the President he kindly told us the same thing, "we are doing something," he said. Well, maybe, but the buildings still go up—what's more, we are too much realists to believe in the hogwash about professionalism.

What we should like to see now would be "every man his own Anti-Ugly." We should like to bequeath our precedent, and even our name if it's any use, to students, housewives, bricklayers, and businessmen all over this rickety, traffic-filled, dull, beautiful island of ours.

CURTAINS FOR CURTAINS?

When speaking before the Building Research Institute in Washington, Architect Alfred Alschuler suggested various ways to defer the demise of curtain walls.

How can an architect work effectively with the manufacturers to create more satisfactory curtain-walled buildings? It is first of all necessary for architects to create attractive designs from which hand-

continued on page 180

IRCLGRID

a NEW product for the ARCHITECT

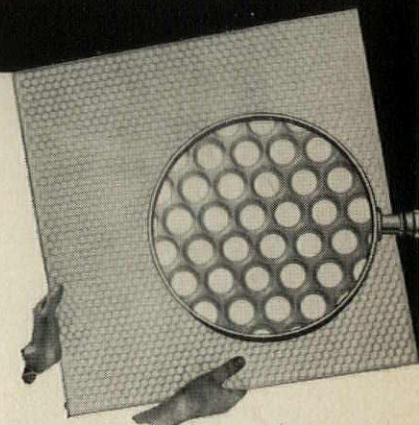

Cross Section through Circlgrid Louver

Nominal Sizes — 2' x 2' x 1/2"
 " " 2' x 4' x 1/2"
 Translucencies — 300-150-75 FC

More than a Luminous Louver

- ▶ It's UL listed-20 (non-combustible)
- ▶ It's both RIGID and LIGHTWEIGHT
- ▶ Outstanding BRIGHTNESS CONTROL

As lighting specialists we developed Circlgrid to meet building lighting codes—it will not support combustion and is safely applied under sprinklers. Circlgrid is thermo-formed from two sheets of vinyl and fused electronically to a center vinyl membrane for structural strength and rigidity—yet weighs only 3 1/2 oz./sq. ft. Many leading lighting equipment manufacturers are licensed to sell and distribute Circlgrid in USA, Canada and other countries.

The moment you see and inspect a Circlgrid sample you'll think of many applications in modern lighting.



Write for sample and technical data.



BOX 655-G • ERIE, PA.
 Illuminating Engineers and Specialists in Vacuum Forming and Electronic Welding

some practical buildings can be built. However, it is up to the manufacturers to provide more flexible, attractive building materials which the architect should demand and can utilize.

If we fail in this joint effort, the brief existence of the modern curtain wall should and will be ended. I recommend that manufacturers of curtain walls and component parts employ imaginative architects to design for them a tremendously appealing building of a different type each month. These solutions will

show the potential development of the curtain wall. One month it could be a home and in succeeding months an apartment building, low-rise office building, housing units, hospitals, schools, industrial plants, and others.

Another approach would be to have a competition between architects in accordance with A.I.A. regulations, seeking the best and most interesting solution to one or several different types of buildings. An imaginative but capable jury would select the best designs to be used in the

advertising literature of the manufacturers. I would hope that this would serve as a stimulus to better curtain-wall design by the architects and more interesting and varied products by the curtain-wall manufacturers.

BENEFICENT HIGHWAYS

The effects of the massive U.S. road-building program were praised rather than censured by highway-buff John A. Volpe, president-elect of the A.G.C., when speaking in Chicago.

The relocation of industrial plants, commercial buildings, and the rapidly multiplying shopping centers out along our highways has inevitably produced many important effects. Land values and land utilization have been drastically affected. While it is true that there has been a substantial increase in the value of farmlands and of residential property adjacent to highway improvements, the factor of land utilization has produced, paradoxical as it may seem, a relative lowering of land cost for certain purposes. For example, the value of land used for industrial purposes in the newly developed areas is much less than the cost of comparable sites in the industrial section of a city. Thus, for industrial and commercial purposes, the movement away from the centers of the old cities has been marked by reduced land costs.

This is by no means the whole story of the social and economic impact of highway improvement. What happens back in the centers of the cities from which so many people and so much economic activity have moved to the more spacious areas along the highways? We all know that to a large extent the central parts of many of our cities have been affected by this movement. But it is my firm belief that the ultimate result of these shifts of population and economic activity will be good.

If our modern age of automotive transportation and technological advancement is to be really fruitful, we must make good use of the tools we have. Not to expand our urban areas as we are doing would mean an impossible congestion, not only of traffic but of everything else, within the narrow confines of our old cities. Something had to give. What gave, in effect, was the city limits.

The result of this and of the extensive renewal that is now taking place in most major urban areas is that in time the decline in the central cities will be arrested and the land will be utilized in better and more profitable ways. The congestion which is paralyzing our central cities will be alleviated by redevelopment and by the relocation of much of our industry and commerce as well as our population. We are beginning to see, in my opinion, the rise of a better way of urban living, with more freedom and less congestion. **END**

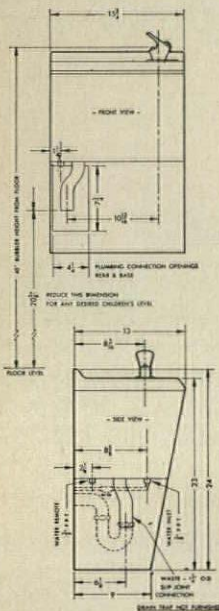

Haws Model HWT-13



CLEAN

from every angle...

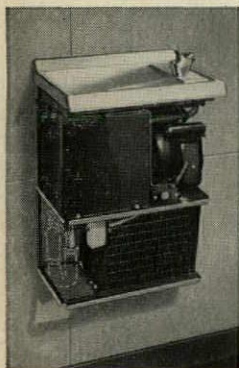

HAWS brilliant new wall mounted electric water coolers are a *clean break* with tradition! Compact design hugs the wall — leaving floor area clear! Crisp, *clean styling* is crowned by gleaming stainless steel — with plumbing and electrical unit completely enclosed. HAWS "clears the deck" for uncluttered maintenance ease and shining *clean floors*. This innovation in water cooler concept and design scores a *clean sweep* for HAWS — leader in the field since 1909! Find out about HAWS' complete line of drinking facilities. See HAWS Catalog in Sweet's Architectural File or write for your copy today.



HAWS DRINKING FAUCET CO.
1441 Fourth Street
Berkeley 10, California

WRITE FOR DATA ON HAWS CAFETERIA AND RESTAURANT WATER COOLERS



Port of New York Authority selects Kalwall "for evenness of lighting — superior thermal and acoustical insulation."
A. Gordon Lorimer, Architect Carl Buhr, Inc., Contractor

Ultramodern control tower at Newark Airport sheathed with translucent Kalwall panels

KALWALL CORPORATION
Dept. A-40, 43 Union St., Manchester, New Hampshire

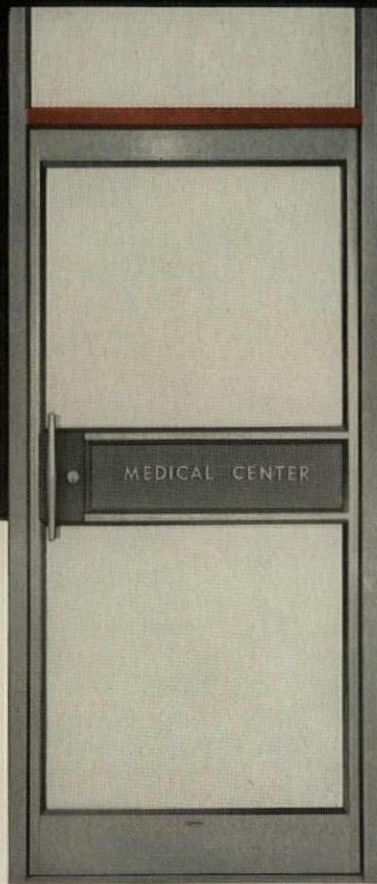

The Style Leader 125 is designed for shops where atmosphere is important, such as jewelry stores, clothing stores and specialty shops, or for banks or stores desiring a prestige appearance.

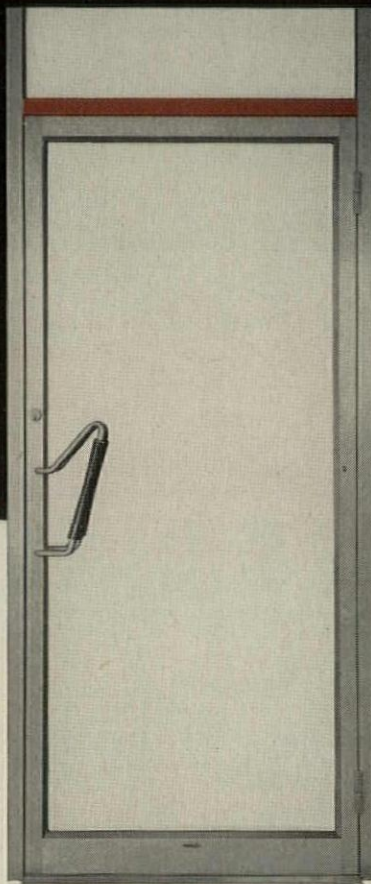

The Narrow Stile 188 is used in stores or buildings which have a normal to heavy flow of traffic.

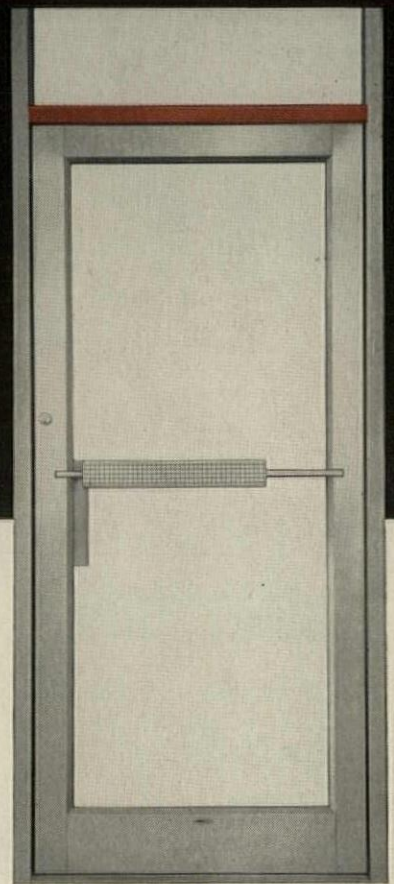

The Extra Duty 350 is for use in stores or buildings which have an extra heavy flow of abusive traffic, such as supermarkets and schools.

*Keys to the slim appearance
and low installed cost of
Kawneer Entrances...
manual or automatic*

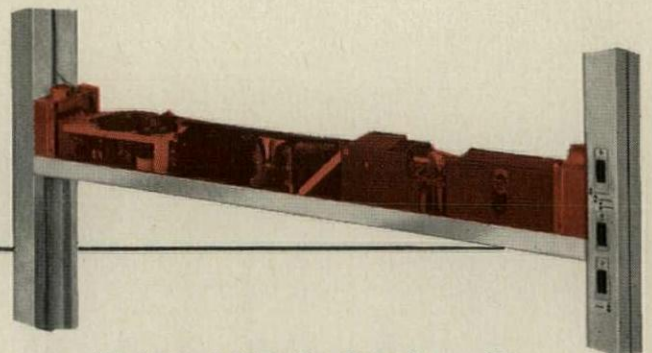

Kawneer Automatic Operator... the new idea in automatic operators. Nothing buried in the floor, nothing hanging over the door. The Kawneer Automatic Operator is completely concealed in the 4½" transom bar, wired to the mat through the frame. Available with all Kawneer entrance packages.

new! KAWNEER DUTY-RATED ENTRANCE PACKAGES

with "tuned-to-the-traffic" design

These new Kawneer entrance packages are built to meet specific entrance needs. They combine the economy of fabrication with custom design flexibility. You choose from

- ... five different doors
- ... twenty push-pull hardware combinations
- ... five (or more) closers
- ... eight frame and entrance wall glazing systems

All components arrive in one package shipment, eliminating catch-as-catch-can deliveries and scheduling problems.

For complete information, tear out this corner and hand it to your nice secretary.

(Nice secretary: write for "The Second New Idea In Entrances", Dept. AF-40, Kawneer Company, 1105 N. Front Street, Niles, Michigan.)

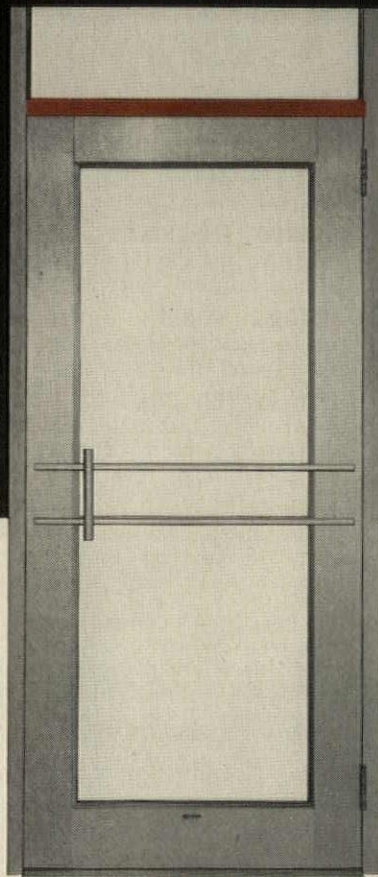

The Wide Stile 500 is for buildings where traffic is both heavy and highly abusive, or where a feeling of massiveness and solidity is desirable, such as banks.

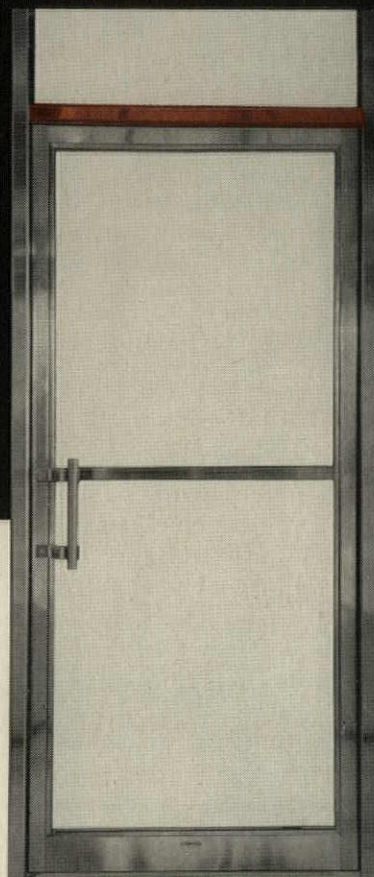

The Stainless Steel 200 has been developed for those applications in which the design and decor of the building or store makes its use preferable.

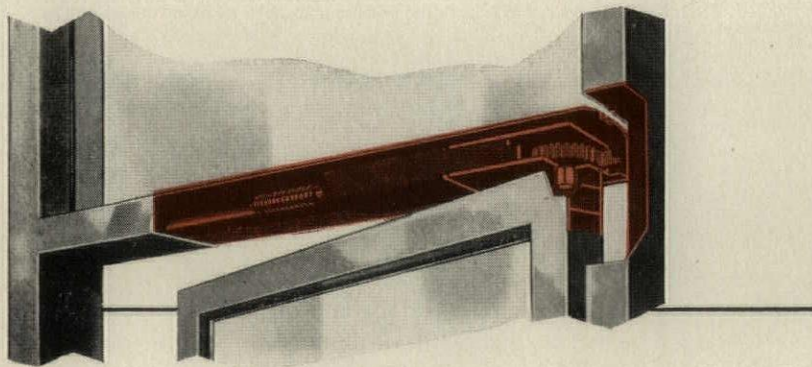

Kawneer Concealed Overhead Closer . . . It introduced the new sheer look in entrances—with low installed cost! No holes to dig, no cement case to set, no complex adjustments to make; this closer is completely concealed in the 1½" transom bar. Available with all Kawneer entrance packages.

why the trend is to

Sani-Dri

speed

New improved, automatic faster drying for washrooms!

savings

Saves 100% on towel costs... 85% on maintenance!

service

Automatic 24 hr. service, no storage, no ordering!

sanitation

Cleaner washrooms — no mess litter or clogged plumbing!



Write Today!

Data Folder gives ideas for modern heavy traffic washrooms... shows how to cut expense and improve sanitation!



THE CHICAGO HARDWARE FOUNDRY CO.
2500 Commonwealth Ave., North Chicago, Ill.

Yes!

Send facts on New Sani-Dri Dryers and washroom planning data.

NAME _____
FIRM _____
ADDRESS _____
CITY _____ STATE _____

MEARLCRETE INSULATING ROOF DECKS

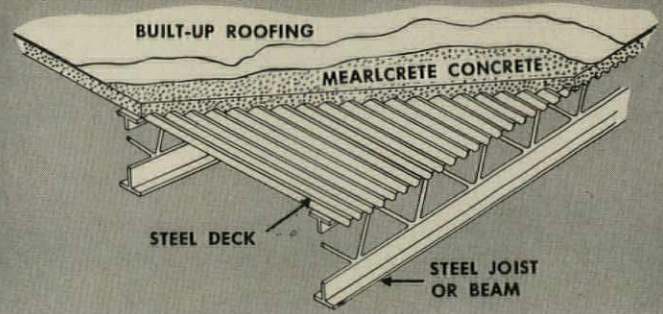

Pumped into place as insulating fill on galvanized corrugated steel decks, or as roof decks on form boards, Mearlcrete Foam Concrete offers many advantages over other systems. Here are a few:

FAST — Place up to 30,000 square feet of roof deck or insulation in a single day.

LIGHTWEIGHT — Permits savings on structural steel frame!

ECONOMICAL — Competitive with all other systems!

CONTROLLED QUALITY — Mearlcrete is installed only by franchised trained contractors.

INCOMBUSTIBLE — 100% concrete reduces heat flow and flame spread.

LOW WATER CONTENT — Less than other poured decks...dries rapidly...permits faster construction schedules.

HIGH INSULATING VALUE — Reduces initial cost and operating cost of heating and cooling plant.

Write for Technical Bulletin R411A with complete data on Mearlcrete Foam Concrete and the name of your local Mearlcrete contractor.

MEARL chemical corporation

220 WESTFIELD AVENUE WEST, ROSELLE PARK, N. J. • CHestnut 5-9500

"We specify MP Plexiglas Drawer Trays"

Pictured below: Hutzler's, Westview, Md.



For latest informative MP brochure and new "Clear-To-See" calculator wheel, without cost or obligation, mail coupon today.

Merchandise
Presentation, inc.

2191 THIRD AVENUE, NEW YORK 35, N. Y., LEHIGH 4-2220

says

Morris Ketchum, Jr., F.A.I.A.
of Ketchum & Sharp, Architects, New York

"Merchandise Presentation Trays are ideally suited to the designing of an integrated store display that is both pleasing to the eye and thoroughly practical for the efficient dispensing of merchandise. We specify MP Trays with complete confidence, secure in the knowledge that they have served so many stores so well."

Hundreds of outstanding stores have been made more efficient, more attractive with MP Plexiglas "Floating Merchandise" Drawer Trays. Crystal-clear MP Trays keep all merchandise in view at all times to spur impulse buying, facilitate selection by salespeople, promote more multiple unit sales. A large variety of stock and custom sizes are available to assure maximum usable space, positive dust-free protection, unparalleled interior beauty.

Merchandise Presentation, Inc., Dept. F-40
2191 Third Avenue, New York 35, N. Y.

Kindly send free calculator wheel and complete descriptive brochure on MP Plexiglas Drawer Trays.

name _____ title _____
company _____
address _____
city _____ zone _____ state _____

Master architects . . . ideal cities . . . community schools

- LE CORBUSIER.** By Francoise Choay.
- FRANK LLOYD WRIGHT.** By Vincent Scully.
- PIER LUIGI NERVI.** By Ada Louise Huxtable.
- ANTONIO GAUDI.** By George R. Collins.
- MIES VAN DER ROHE.** By Arthur Drexler.
- ALVAR AALTO.** By Frederick Gutheim.

All published by George Braziller, Inc., 215 Fourth Ave., New York 3, N.Y. 125-136 pages. 7½" x 10¼". Illus. \$3.95 each.

These six attractively packaged volumes comprise Braziller's "Master of World Architecture" series. The selection of the architects and the authors to introduce them is admirable. Yet somehow the whole collection is disappointingly thin.

Perhaps this is because there is very little real discovery, either in buildings pictured, details analyzed, or theories advanced. But more likely the unsatisfactory impression results from the editor's decision not to coordinate text and pictures. The constant references to pictures in the back of the book becomes wearing and finally defeating.

It is notable in this connection that the book that has the most complete picture captions, George Collins' study of Gaudí, is generally the most impressive.

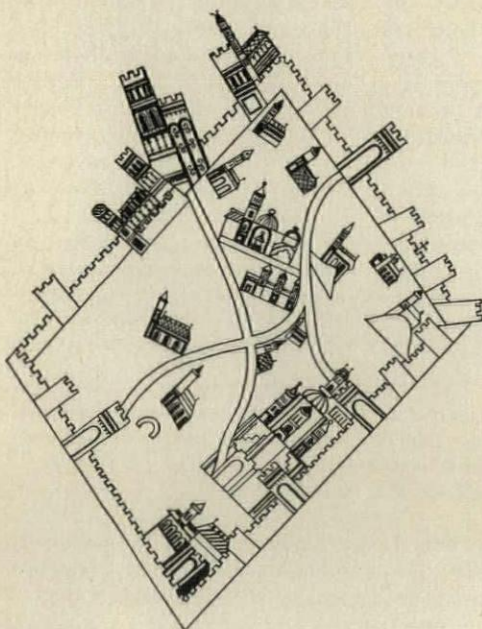

THE IDEAL CITY in its architectural evolution. By Helen Rosenau. Published by Boston Book and Art Shop, Inc., 657 Boylston St., Boston 16, Mass. 6¼" x 9¾". 168 pp. Illus. \$6.

In the current spate of books on cities too many promise more than they deliver. *The Ideal City* is an exception. Modestly bound, small and thin, and not especially handsome, the book nevertheless opens delightful vistas for the civic scholar, many

illustrated in token fashion, at least. Unlike so many books in the field, this one is frustratingly concise. A civic designer of importance during the Italian Renaissance, Architect L. B. Alberti, gets three or four pages and one or two illustrations to himself with about six tie-in references; the great Baron Haussmann is merely mentioned twice. But the fact that Haussmann gets lesser billing than Alberti is, these days, a significant fact itself.

Figures like Alberti, Piranesi, and Dürer march through the book with figures even more obscure—and herein lies its significance. This is a book on the *thinkers* about cities rather than the *doers*. To read it is to go through a kind of card index on city planning theory.

EXPERIENCING ARCHITECTURE. By Steen Eiler Rasmussen. Published jointly by Technology Press of Massachusetts Institute of Technology and John Wiley & Sons, Inc., 440 4th Ave., New York, N.Y. 251 pp. 6" x 9". Illus. \$4.50.

Danish Architect Steen Eiler Rasmussen is professor of architecture at the Royal Academy of Fine Arts in Copenhagen, and has lectured at a number of British and U.S. universities. Despite these academic credentials, somehow he still can talk about architecture so that outsiders know exactly what he means.

This book, which is aimed primarily at the young person who is interested to find out what architecture is all about, is lively, without ever becoming condescending and learned, without ever becoming dull. Author Rasmussen starts his readers off on the right track by awakening their visual senses, then proceeds to organize his material not by historical style but by forces that are rather more important to good architecture. As he ticks them off, these forces are: solids vs. cavities, planes, proportion, rhythm, texture, light, color, and sound. And throughout the work he weaves history and changing philosophies and the human condition as unforgotten background music.

The result is a book of great charm and broad understanding.

ARCHITECTURAL RENDERING: The techniques of contemporary presentation. By Albert O. Halse. Published by F. W. Dodge Corp., 119 W. 40th St., New York 18, N.Y. 277 pp. 8¾" x 11½". Illus. \$15.75.

No doubt this book will become the basic text in the rendering field—if, by rendering, is meant the art of preparing utterly realistic impressions of architecture for presentation to persons of little imagina-

continued on page 186

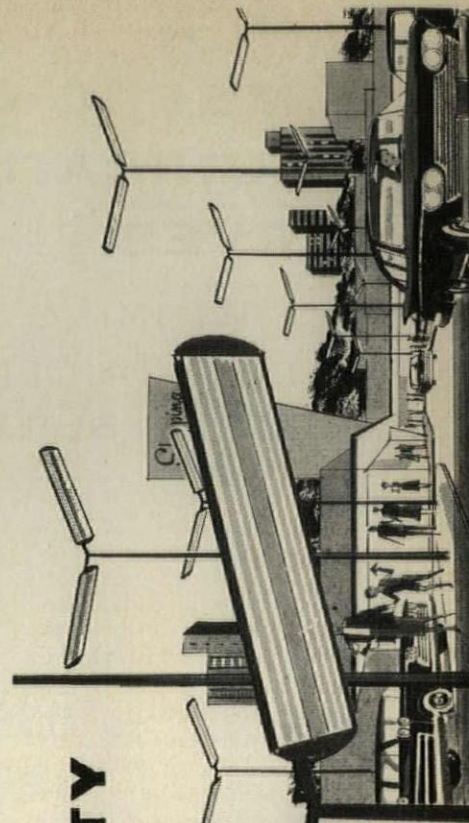

STRENGTH . . . COLOR FIDELITY
'Beauty on High' by **ELSCO**

Don't be deceived by the clean, almost delicately poised, beauty of ELSCO'S new model SCL high-mount all-aluminum fluorescent luminaire. Construction is weather-proof all the way, with strength aplenty to resist whipping winds. Write today for free attractive literature detailing ELSCO'S complete line of parking area lighting fixtures.

Electric Lighting, Inc. Dept. 3, 633 San Juan Ave., Stockton, California

HOW A STROMBERG-CARLSON COMMUNICATION SYSTEM SERVES

PRIZE-WINNING DUPONT PLAZA CENTER ...HOME OF BUILDORAMA

A prize-winning architectural achievement, the Du Pont Plaza Center in downtown Miami promotes the nation's finest building, decorator and accessory items through displays in Buildorama.

The triple-service structure—the first of its kind in the world—marks a new, practical integration of display area, office space and hotel facilities. And a Stromberg-Carlson integrated sound system was selected to provide the utmost in complete, modern communications for the entire center. The installation includes:

- Five-channel radio system, with one channel available for an outside music source.
- Two-channel music system for the hotel to deliver music—or music and paging—to any individual area.
- Maid's call for selective location of maids.
- Complete sound system for Buildorama, the Architects' International Bu-

reau of Building Products.

- Large number of selector stations which permit selection of 11 programs for distribution to any point.
- Latest master antenna equipment, closed-circuit systems, large projection TV sets, and intercom facilities between message centers.

The Stromberg-Carlson system doing this big job was "custom-engineered" from standardized components. Such an efficient, economical system is available to meet your needs in all types of construction.

Our field engineers are available for consultation on your current and future projects. Our factory-trained distributing organization is ready to handle all installation and maintenance problems. Look in the Yellow Pages under "Public Address & Sound Equipment," or write to Special Products Division, 1414-04 North Goodman Street, Rochester 3, New York.

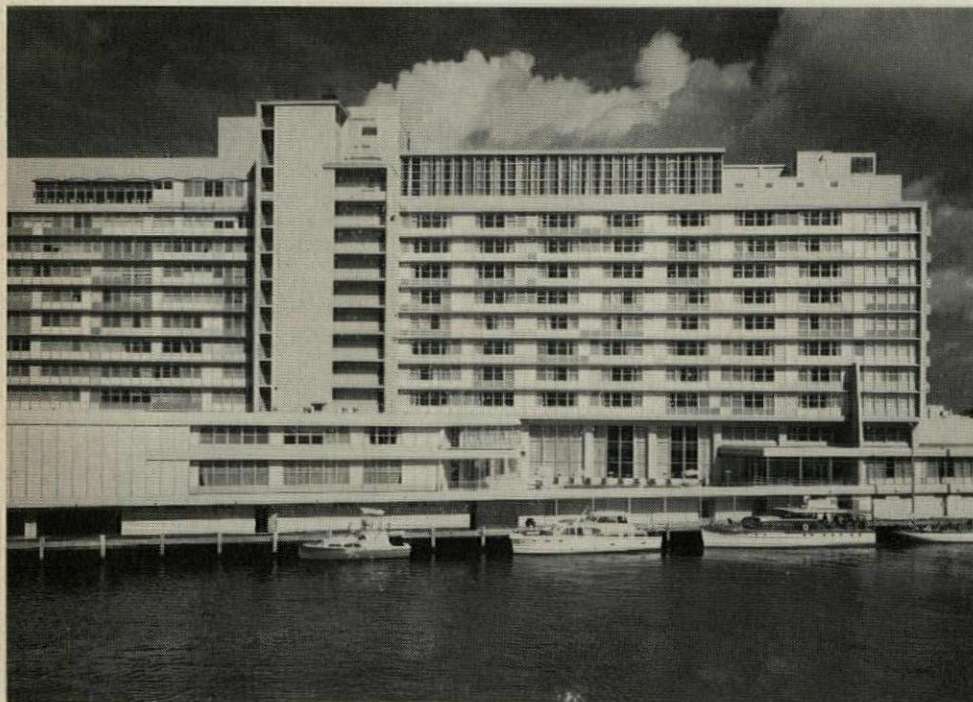

Sound installation by Bell Television of Florida, Inc.

"There is nothing finer than a Stromberg-Carlson"

STROMBERG-CARLSON
A DIVISION OF **GENERAL DYNAMICS**

tion and less poetic instinct. But, as the all-too-short historical chapter demonstrates, the art of rendering can excite the eye as well as inform it.

If a young man of talent wanted a text to help him obtain a sure grounding in techniques and processes, he should read this book. But he should be careful lest he study it so well that he lose his spark.

PLANNING AMERICA'S SCHOOL BUILDINGS.

A report of the School-Building Commission of the American Association of School Administrators, 1201 16th St., N.W., Washington 6, D.C. 229 pp. 8½" x 11", \$6

PLANNING YOUR SCHOOL BUILDING DOLLAR.

By Carl H. Stautz. Published by the Chilton Co. Book Division, Philadelphia 39, Pa. 116 pp. 7" x 10". \$2.75.

It is undoubtedly not mere coincidence that two such similar books should appear in print almost simultaneously. Rather, their publication points up the magnitude of the current school-building problem in America. Each of these volumes, in its way, is a worth-while contribution to a better understanding of the classroom emergency: neither is an extremist's book of panaceas or easy solutions.

Planning America's School Buildings is the work of a seven-man committee* of some of the most respected people in the school-building field. In their view, the school plant is a translation of the curriculum and all that it involves into teaching facilities and space. Thus, their effort aims to aid in planning and building schoolhouses and to be of value to the curriculum-maker as well. It covers every facet of school-building planning in thoughtful, thorough steps.

Planning Your School Building Dollar is more of a "how-to" type of book, offering a "plan of action" by which "any school board can build school buildings within its bond issue—no guesswork, no mystery, no unfortunate 'cost' surprises at the conclusion of the work." It is written in a somewhat relaxed style, apparently for the dedicated though uninformed school-board member who wants to serve his community well. And as such, it is a worth-while book.

DESIGN OF INDUSTRIAL EXHAUST SYSTEMS.

By John L. Alden. Third Edition. Published by The Industrial Press, New York 13, N.Y. 243 pp. 6¼" x 9¼". Illus. \$6.

This is an updated version, meant to serve as a guide in the design, construction, or purchase of industrial exhaust systems.

*The members of the A.A.S.A. School Building Commission are: Architect Charles R. Colbert, of New Orleans; Shirley Cooper, of A.A.S.A.; William H. Curtis, supervising principal, Bellport, N.Y.; Charles D. Gibson, chief of the Bureau of School Planning, California Department of Education; Robert S. Gilchrist, superintendent of schools, University City, Mo.; Architect John W. McLeod, of Washington, D.C.; and Arnold S. Tjomsland, director of School Plant Facilities for the State of Washington's Board of Education.

continued on page 188

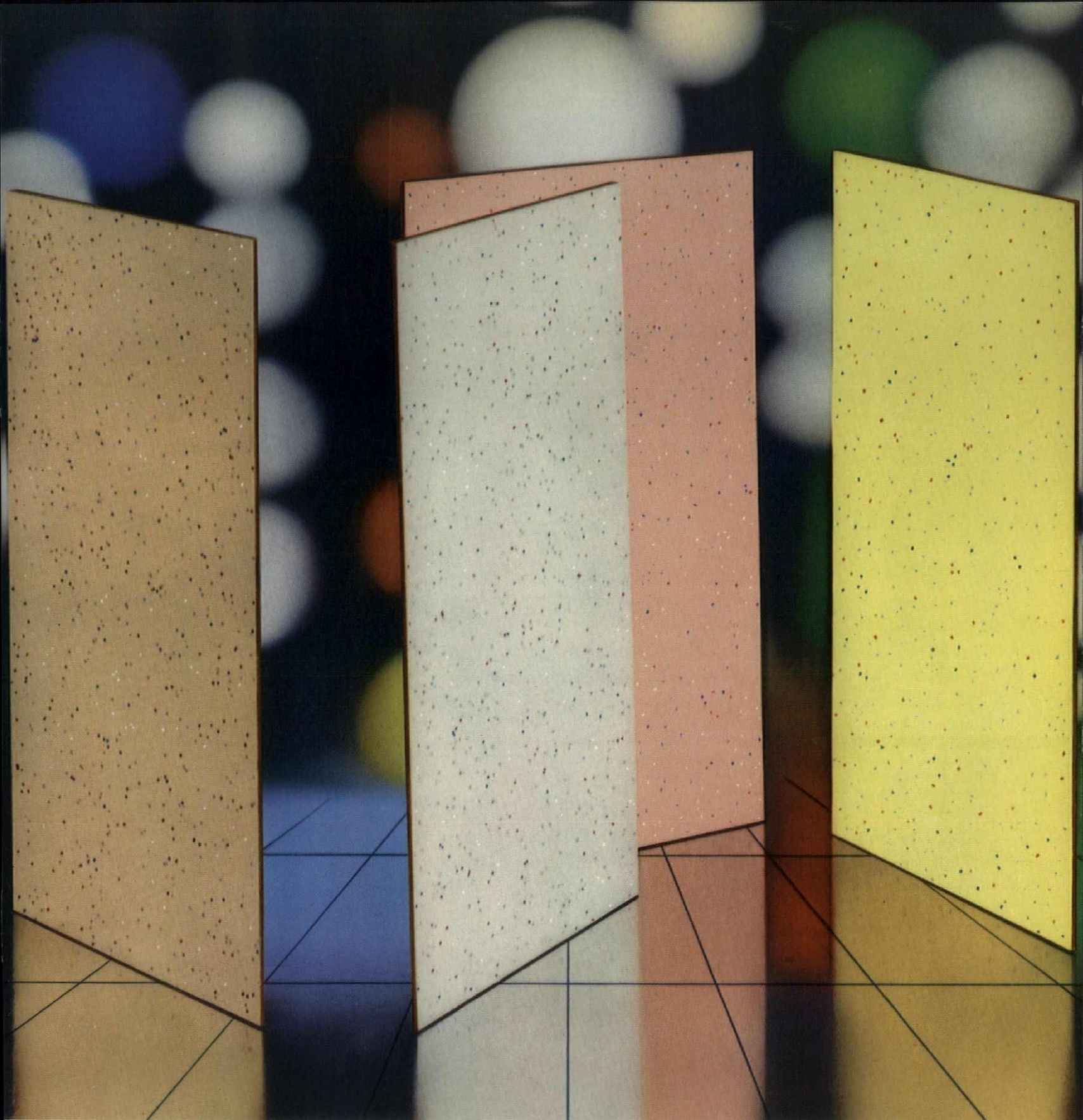

New Iridescence reflects modern design

A rainbow-like galaxy of color glimmers and glows in this attractive new pattern from Panelyte®. Once again, America's style leader in decorative laminates makes a splendid new addition to its rich, colorful line. And it can be a new addition to *your* storehouse of imaginative ideas for interiors. For "IRIDESCENCE" is designed to brighten almost any interior surface . . . *durably* designed to stay lastingly new over the years. That's something to reflect on, too.

AIA File No. 23-L1960

May we send you free samples of color-coordinated Panelyte? Write Panelyte Division, St. Regis Paper Company, 150 East 42nd Street, New York 17, N. Y.



Chem Marine
TRADEMARK

IT PAYS TO HAVE
HUBBELL
GOOD CONNECTIONS
REG. U.S. PAT. OFF.

UL
UNDERWRITERS LABORATORIES

a complete new line
of exceptionally
rugged wiring devices
that withstand
adverse conditions

RESISTS CORROSION

Special Materials:

This new super line of "Chem Marine" devices are engineered from corrosion resistant materials capable of withstanding the harmful effects of moisture, brine, grease, oils and many acids. They are designed for industrial applications such as plating rooms, shipping platforms, yards, shops, warehouses, or wherever corrosion or chemical action is a problem.

"INSULPRENE"—a Du Pont neoprene compound.

"MONEL® METAL"—Reg. Trademark of INCO.

"MELAMINE"

"CYMEL®"—Reg. Trademark of Am. Cyanamid

**HEAVY NICKEL-PLATED
CURRENT CARRYING PARTS.**

52CM62
3-wire, 15 amp, 125 volt
"Melamine" Duplex
Grounding Receptacle

74CM20
Metal Weatherproof Lift Cover Plate
with heavy vinyl coating for single
receptacles. Shown with 73CM10
"Twist-Lock" Receptacle and
mounted to standard FS box.

17CM51
Weatherproof "Insulprene"
Plate and A.C.
"Pressswitch" Combination.

52CM11
Weatherproof Lift Cover Plate
for duplex receptacles used
with FS boxes.

99CM60
Shown with
"Insulprene"
"Seal-Tite"
Cover 75CM31

99CM66
3-wire, 20 amp.
"Insulprene"
"Twist-Lock"
Connector Body

Listed by:
Underwriters' Laboratories, Inc.

"Chem Marine" devices are identified by their bright yellow color and a few representative items are illustrated above. For complete information contact the "Chem Marine" Department. —

HARVEY HUBBELL, INCORPORATED
BRIDGEPORT 2, CONNECTICUT, In Canada: Scarborough, Ontario

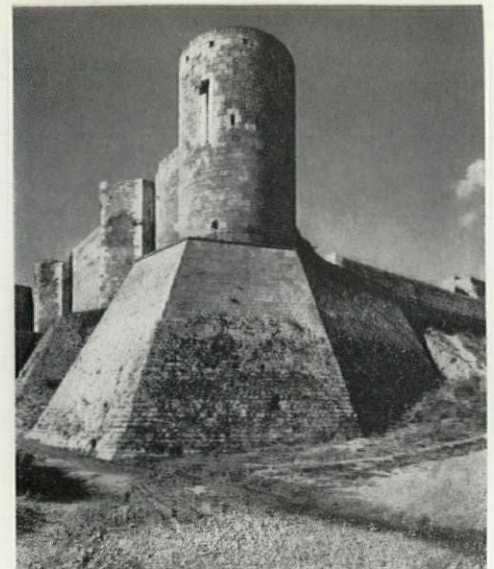

APULIA: Imperial splendor in Southern Italy.
By C. A. Willemsen and D. Odenthal. Published by Frederick A. Praeger, 15 W. 47th St., New York 36, N.Y. 257 pp. 9 1/4" x 11". Illus. \$12.50.

THE ART OF INDIA: TEMPLES AND SCULPTURES.
By Louis Frederic. Published by Harry N. Abrams, Inc., 6 W. 57th St., New York 19 N.Y. 268 pp. 9" x 12 1/2". Illus. \$17.50.

Two exotic picture books of special interest to wandering architects. Apulia, which is the ancient name of that southeastern part of Italy better known as Puglia, is a peculiarly rich area for those who don't mind going off the beaten path in either geography or chronology (Apulia's heyday was 1043-1250). The photo above is of Frederick II's fortress palace.

Now very much on the beaten track is India—and Author Frederic's introduction to its artistic and architectural delights should be read by anyone who would go there. Worth discovering, for example, is that the Gol Gumbad (1660) in Bijapur, illustrated below, covers a perfect acre and has a St. Peter's-size central dome.

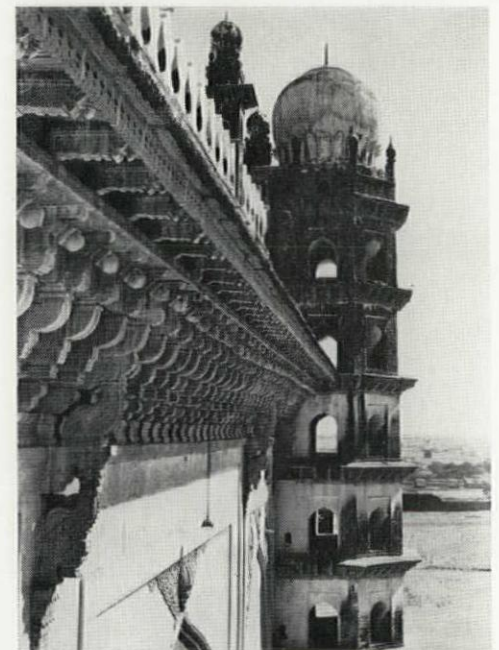

END

shaped for '60 . . .

the NEW DUNHAM-BUSH 'LSBC'

...a Low Silhouette Blower Condenser
that offers high
performance and exceptional
installation flexibility



Inner-Fin
Construction

The shape of the Dunham-Bush 'LSBC' really has a function . . . the low lines of this new air cooled blower condenser give it an important application/installation superiority over similar units of different design.

Because its new engineered shape ensures safe pounds-per-square-foot loading, the 'LSBC' can be installed virtually anywhere on any roof, without the costly reinforcement of roof members usually necessary to support heavier units. And, the low, compact 'LSBC' is easily accommodated within minimum space, yet has the operational and construction features to meet the most rigid performance demands. Air movement is up and out, meaning minimum noise rating.

Other major features include a high efficiency inner-fin condenser coil with less internal volume and therefore smaller refrigerant charge . . . drip-proof, NEMA frame, grease-lubed ball bearing type motors, with an adjustable base to facilitate belt tension adjustment.

The 'LSBC' is available in a variety of circuits. Models range from 5 to 53.5 tons.

For further information, write for Form No. 7011-1, or call the Dunham-Bush sales engineer near you.

Dunham-Bush, Inc.

WEST HARTFORD 10 • CONNECTICUT • U. S. A.

DUNHAM-BUSH

AIR CONDITIONING • REFRIGERATION • HEATING • HEAT TRANSFER

WEST HARTFORD, CONNECTICUT • MICHIGAN CITY, INDIANA
MARSHALLTOWN, IOWA • RIVERSIDE, CALIFORNIA

SUBSIDIARIES
HEAT-X, INC. DUNHAM-BUSH (CANADA), LTD.
BREWSTER, N.Y. TORONTO, CANADA

DUNHAM-BUSH LTD. BRUNNER CORPORATION (CANADA) LTD.
PORTSMOUTH, ENGLAND PORT HOPE, ONTARIO

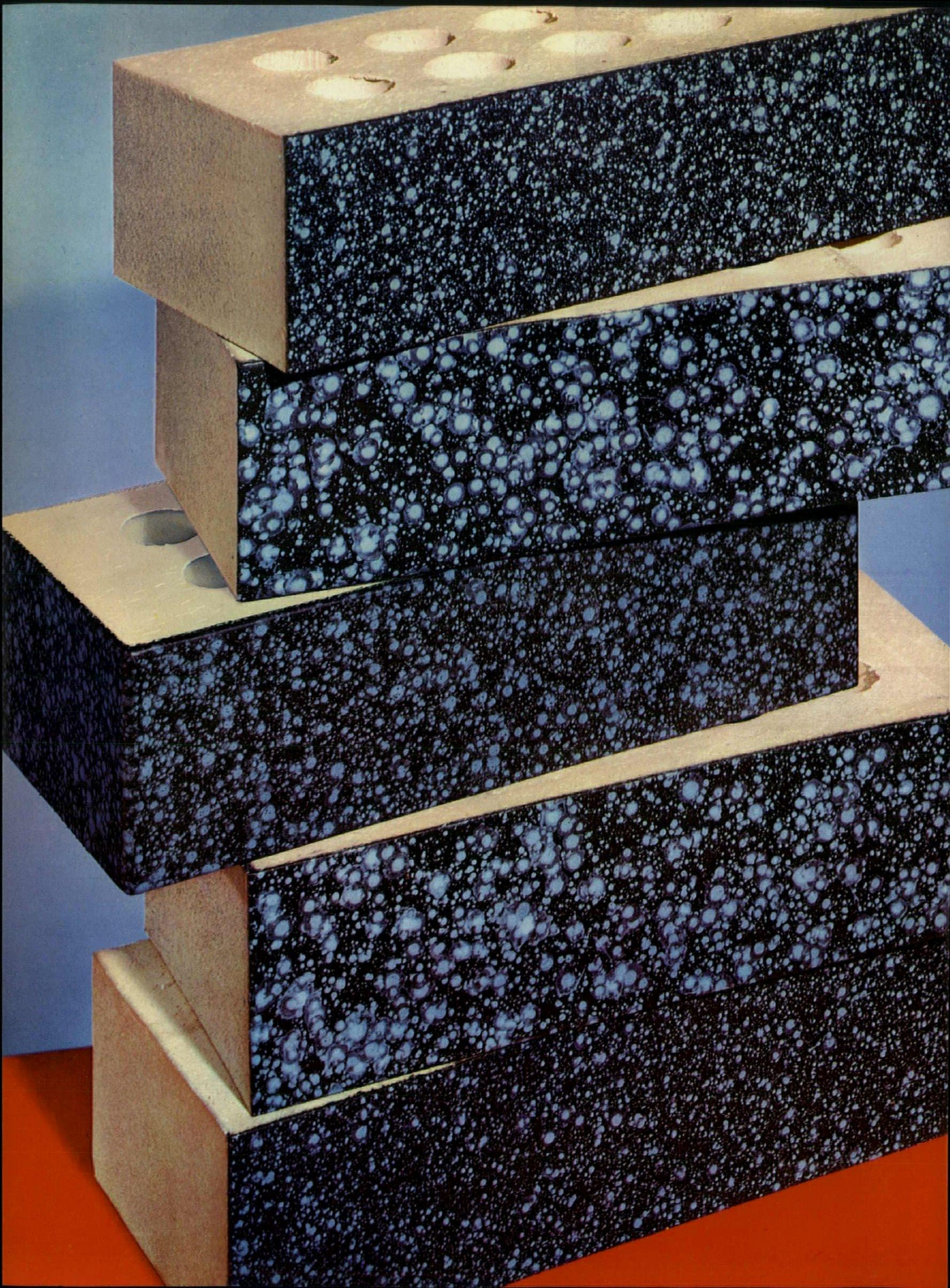

NEW COLOR EXCITEMENT

with

**DARLINGTON
STASO**

KolorspeK*

STASO KolorspeK combines the permanence of brick curtain wall construction with the beauty of the richest marble—an achievement of the master brickmaker's art. This new glazed brick will reflect the creative touch of the skilled architect in a building of modern elegance and incomparable beauty.

KolorspeK is available in four color ranges—Black Opal, Dutch Blue, Cinnamon, Mosaic Gray.

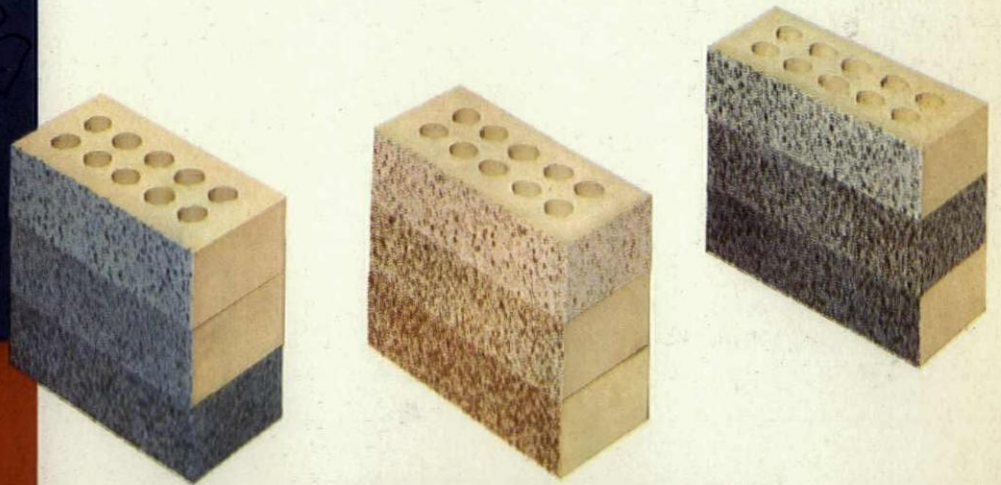

**DARLINGTON STASO
GLAZED BRICK**



Permanent Beauty in Color Ceramics

Also Available in Satin Finished Glazed Pastel Colors by
Manufacturers of Darlington *Royal* Face Brick.

CENTRAL COMMERCIAL COMPANY (Est. 1894)
332 South Michigan Avenue • Chicago 4, Illinois

*T. M. Pending — Patent Applied For

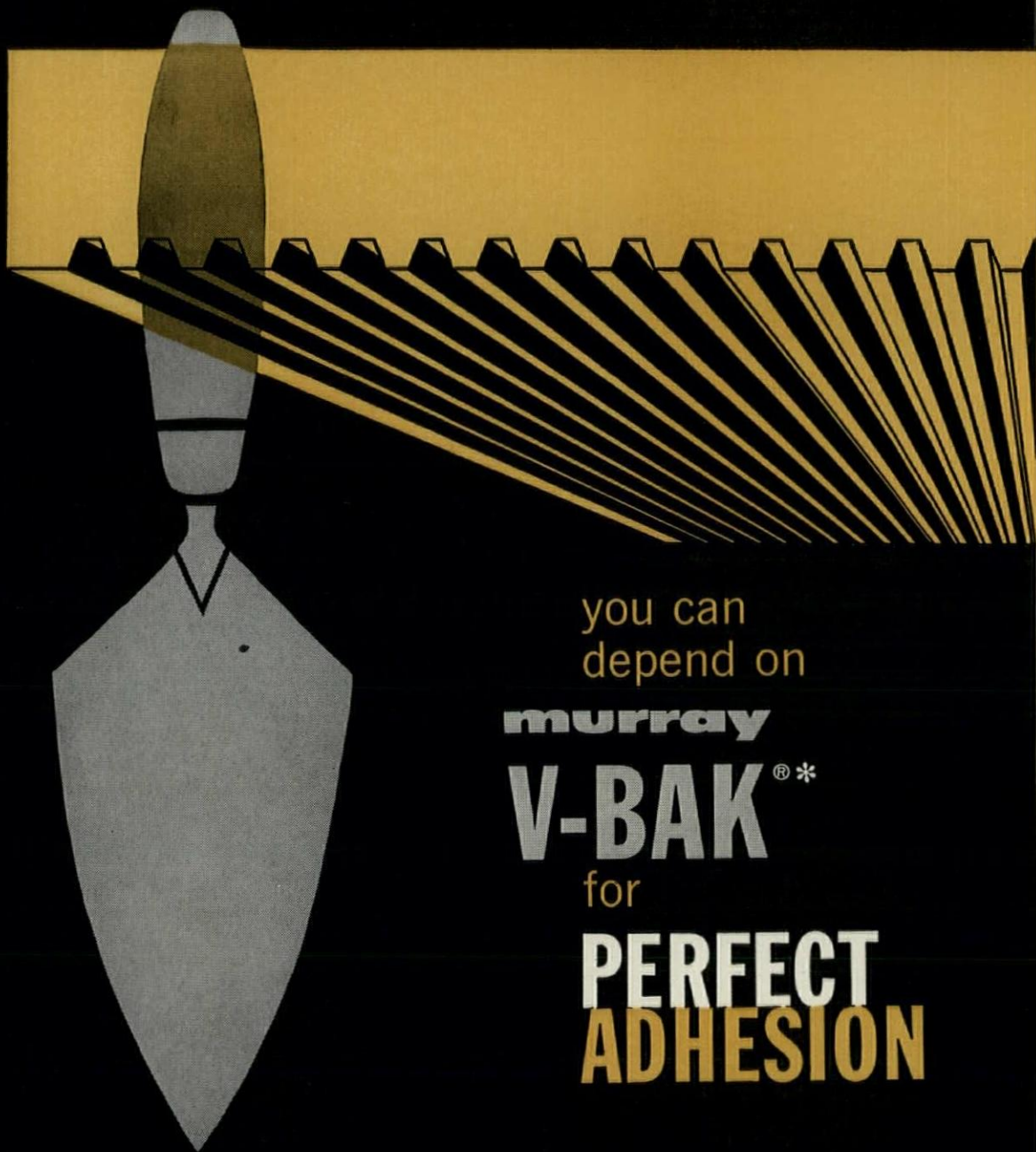

you can
depend on

murray

V-BAK^{®*}

for

**PERFECT
ADHESION**

When you are looking for economical, long lasting floors specify Murray V-Bak Quarry Tile. V-Bak provides 23.5% more bonding surface and requires 56.5% less bonding material.

Let us explain in detail!

murray TILE COMPANY INC. LEWISPORT, KY.
V-BAK[®]
DIVISION OF AMERICAN OLEAN TILE COMPANY

V-Bak Quarry Tile gives you all these features:

1. Perfect adhesion
2. Uniform size
3. Uniform color
4. Even texture
5. Smooth surface
6. Low maintenance
7. Lasting service

A.I.A. File No. 23-A-1

*PAT. PEND.

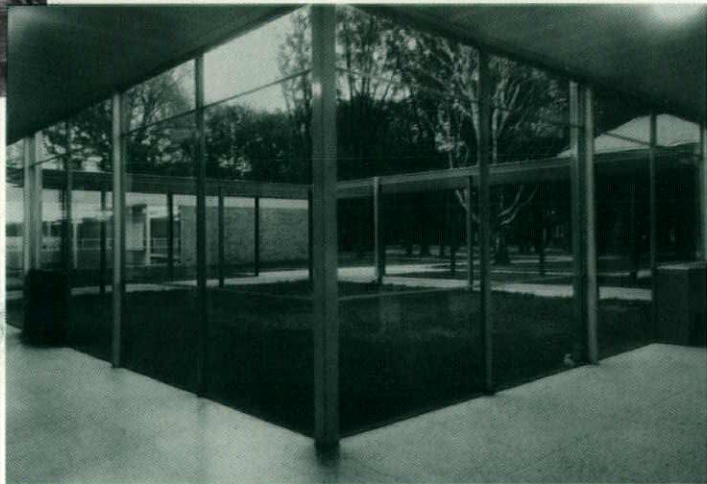
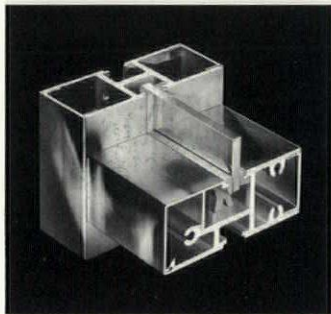

Glass does things to a building—It brightens the inside, colors the outside, gives design character to *every* side. Today, from one source, you can get all kinds of glass and metal products for schools and other commercial structures. That source is close to you. There are Pittsburgh Plate Glass Company branches and distributors everywhere. W. P. Fuller Company distributes PPG glass products on the West Coast. Your PPG architectural representative has all the information about the glass, the metal framing members, the insulation, the sealants, the glazing—the complete Pittsburgh curtain wall system. Check with him on any PPG product, or see our catalogs in Sweet's.



Pittsburgh Plate Glass Company

Paints • Glass • Chemicals • Fiber Glass

In Canada: Canadian Pittsburgh Industries Limited



Glass for design—The Ponce de Leon Motor Lodge in St. Augustine, Florida, has 60 comfortable units to accommodate guests. And it's a beauty, because of glass. Glass issues a wide-open invitation to motorists to drive in and relax. The lines are trim, clean, modern as only glass can make them. The Ponce de Leon's glass is green tint PENNVERNON® SOLEX® heavy sheet, to reduce glare and heat . . . plus clear Polished Plate Glass and clear PENNVERNON window glass, all PPG. Doors and sidelights are HERCULITE®, Pittsburgh's super-strong tempered Plate Glass. Call in a PPG architectural representative today. His training, his experience can be invaluable to you.



PITTSBURGH GLASS . . . the basic architectural material



Architects: Saxelbye & Powell, Jacksonville, Fla. Contractor: Florida East Coast Hotel Company, St. Augustine, Fla. Glazed by Service Paint & Glass Company, St. Augustine, Fla.





Glass for color—The Hammermill Paper Company's new Administration Building in Erie, Pennsylvania, features glass curtain walls alive with attractive color. The panels are SPANDRELITE®—heat-strengthened glass with ceramic color fused to the back. The color can't fade, can't wear off. And because they're glass, the panels stay smooth and flat. The metal framing is PITTCO® 82-X, specially developed for glass-clad construction. Its leakproof performance is assured by a remarkable PPG sealant—Butane Duribbon. Duribbon seals out moisture indefinitely. The building's vision areas are glazed with TWINDOW® insulating glass units, one pane of which is SOLARGRAY® glare- and heat-reducing Polished Plate glass. PPG welcomes *sole* responsibility for its curtain wall systems. Write for our full-color booklet on Glass-Clad Curtain Wall systems. Pittsburgh Plate Glass Company, Room 0128, 632 Fort Duquesne Blvd., Pittsburgh 22, Pa.



PITTSBURGH GLASS . . . the basic architectural material



Architects: Daniel, Mann, Johnson & Mendenhall, Los Angeles, Calif. Contractor: Rust Engineering Company, Pittsburgh, Pa.



Glass for light—Today's school architect designs with natural light. With glass, he builds walls of light to enliven the routine of study, to bring the outdoors in and make going to school more inviting. Gordon Road Elementary School, St. Clair Shores, Michigan, is a case in point. It's the kind of school you would have enjoyed attending. Take a stroll around it, through it, you'll find glass everywhere . . . doing a job no other material can do. All of this glass was supplied by Pittsburgh Plate Glass Company.



PITTSBURGH GLASS . . . the basic architectural material

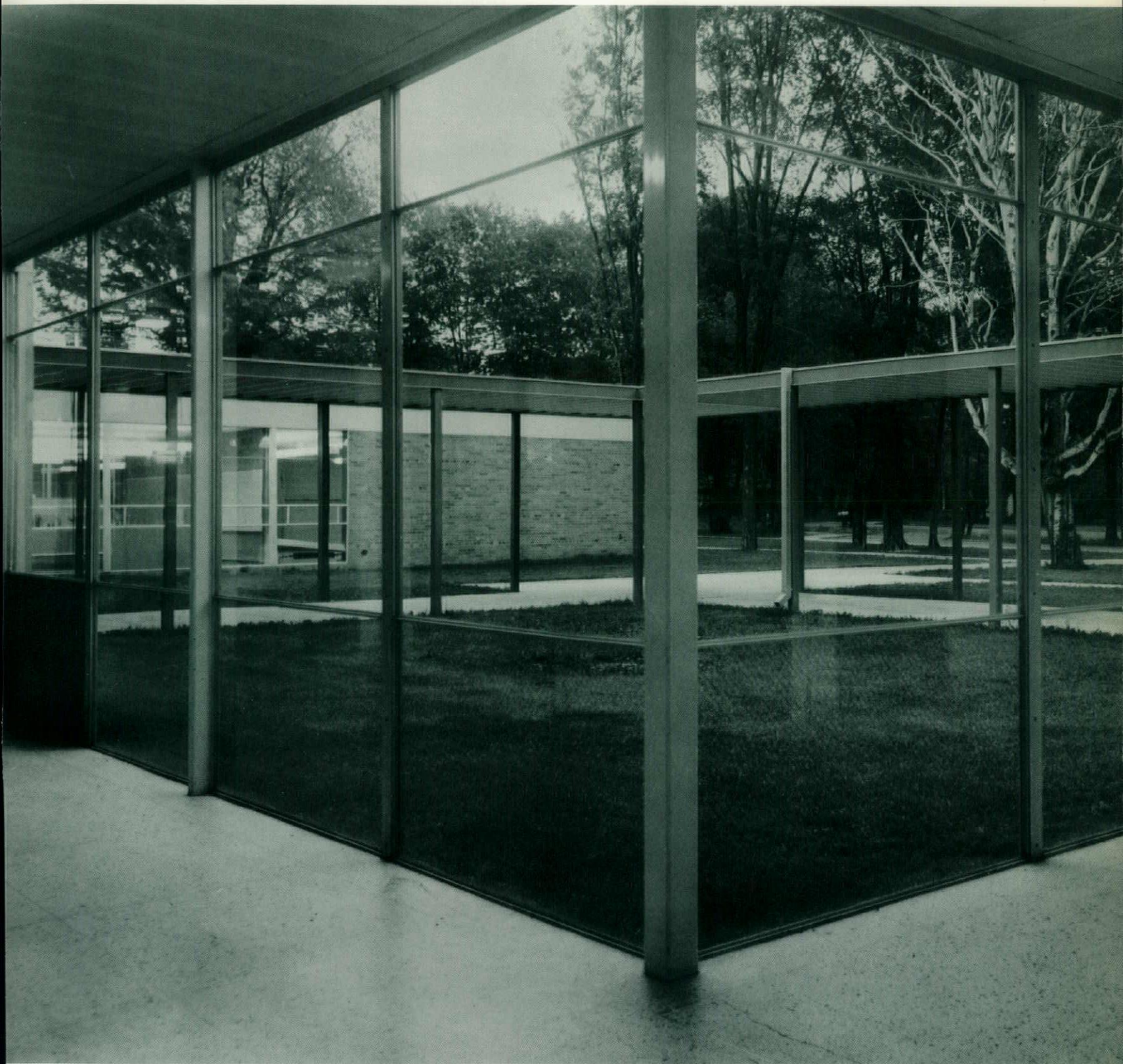

*Architects: Wakely-Kushner Assoc., St. Clair Shores, Michigan Contractor: Petku Construction Co., Birmingham, Michigan
Glazed by City Glass Company, Detroit, Michigan*

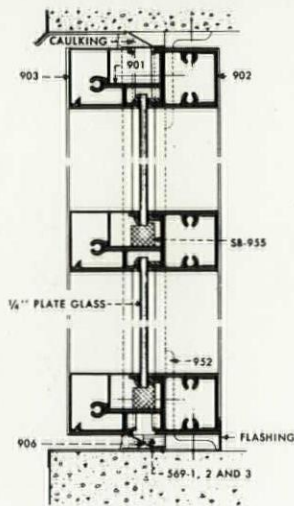
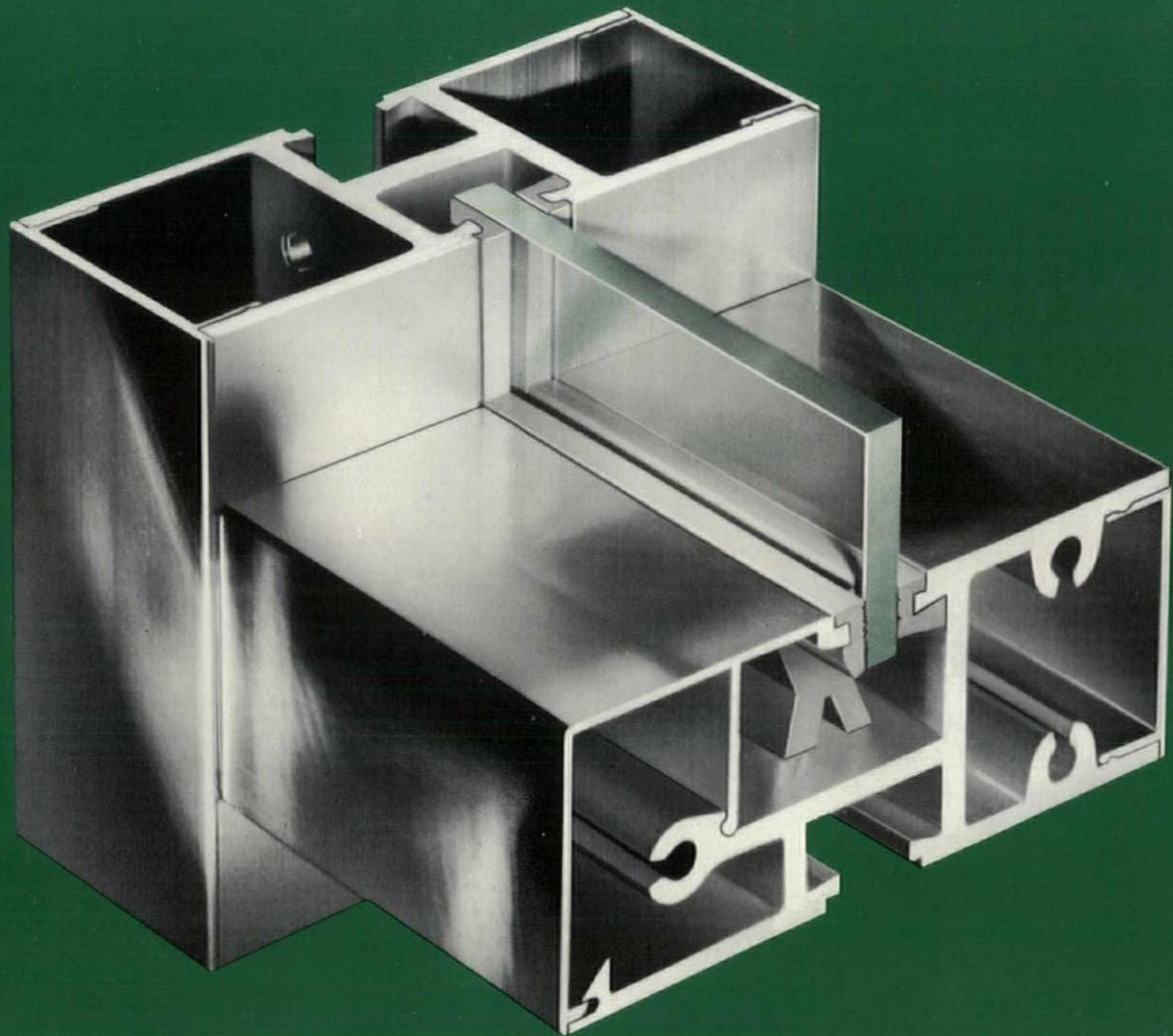

The new PITTCO "900" Series—You can frame windows and glass-clad walls completely with the related components of the new PITTCO® "900" series. It is provided with a drainage system. All members are aluminum; all fastenings are concealed; all glass is held in neoprene strips and recessed to increase daylight opening. And the clean beauty of every line is strikingly apparent. For details, consult your Pittsburgh architectural representative.



Pittsburgh Plate Glass Company

Paints • Glass • Chemicals • Fiber Glass

In Canada: Canadian Pittsburgh Industries Limited

JOB REPORT: NELSON Stud Shear Connectors In Composite Construction NELSON stud shear connectors and Cofar corrugated steel forming, provided a time and cost-saving combination in IBM's three-story education building.

COMPOSITE CONSTRUCTION* ...In IBM education center

Architects and engineers who designed International Business Machines Corporation's education center in Poughkeepsie, N. Y. specified the newest concept in modern building design—composite construction...

*A steel and concrete composite beam is made up of three essential elements: A steel beam, a reinforced concrete slab, and shear connectors. Horizontal shear is transferred to the beam through the shear devices which join the slab to the beam in such a way as to cause the concrete and steel to act as a unit.

Architecturally—composite construction permits wide spacing of columns, resulting in unobstructed floor space. The construction depth is reduced so that the over-all building cubage is reduced.

Structurally—the cured concrete slab and beam, acting as a composite unit, provide a higher section modulus than the same non-composite steel beam could afford... permitting a reduction in beam size required to carry the specific load.

To gain these advantages, the engineers specified composite construction with Nelson Stud Shear Connectors... for economy, ease of installation, reduction in handling time and earlier field completion.

Look into the advantages of composite construction for your next job. Call in your local Nelson field representative, or write for "The Case For Composite Construction". Nelson Stud Welding Division, GREGORY INDUSTRIES, INC., Department 21, Lorain, Ohio.

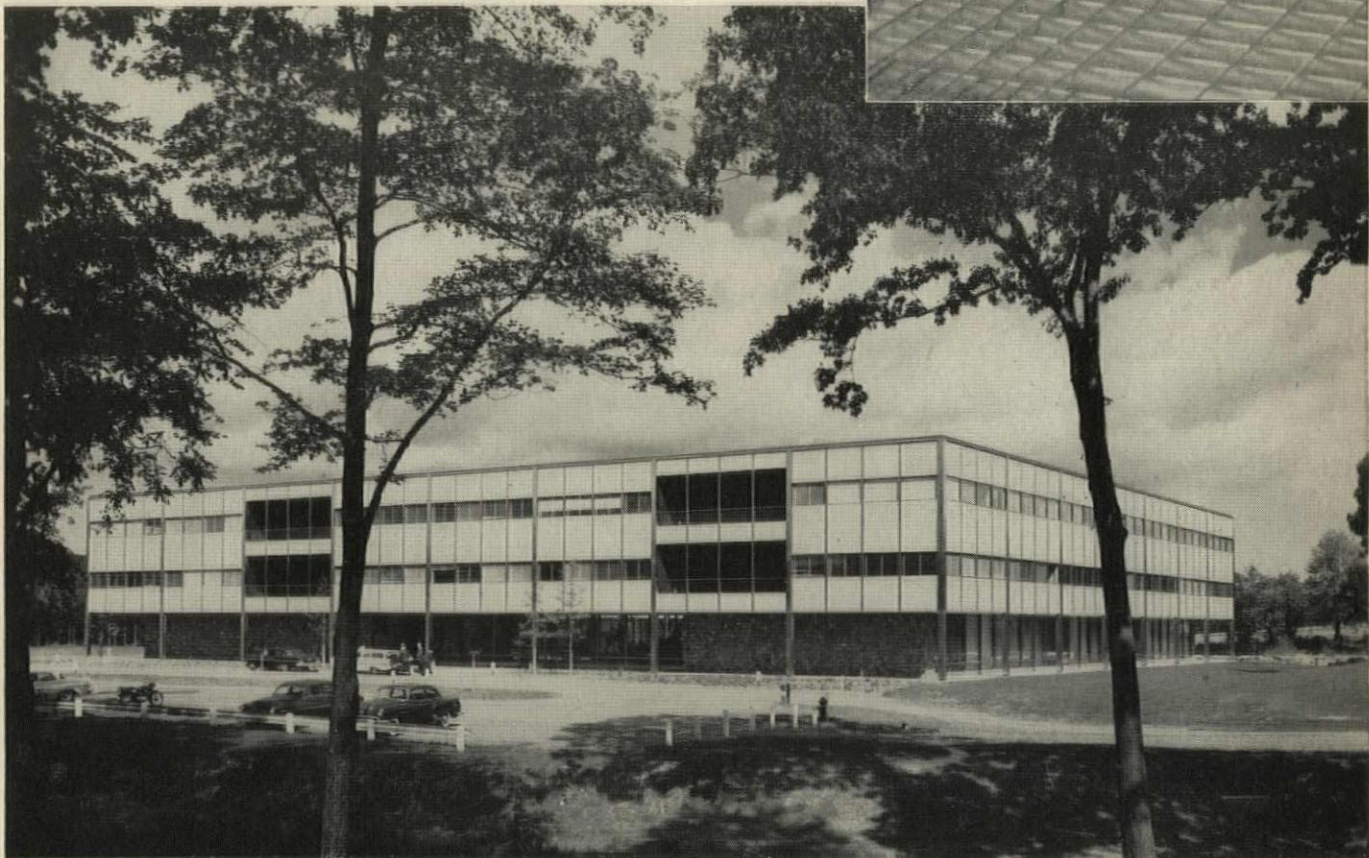
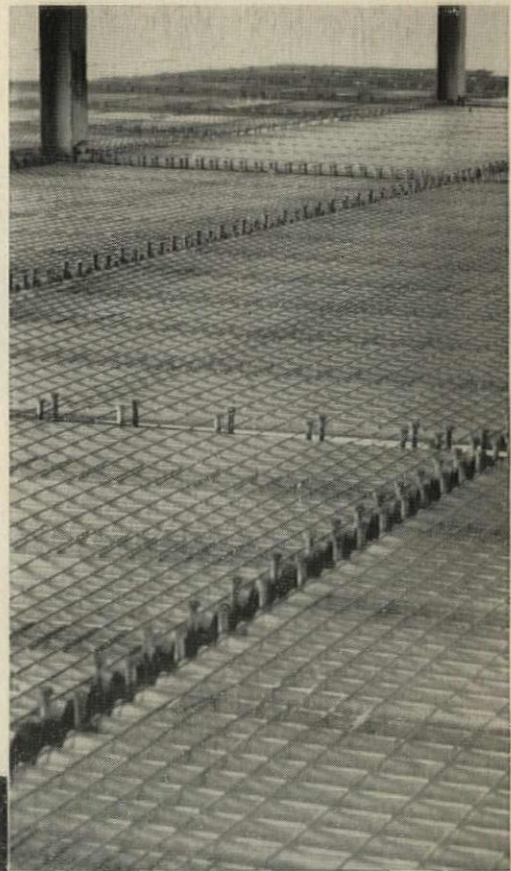

IBM EDUCATION CENTER, Poughkeepsie, N. Y. Architects and Designers: Eliot Noyes and Associates. Consulting Engineers: Seelye Stevenson Value and Knecht. General Contractor: Walter Stanley Construction Company. Structural Steel Contractor: White Plains Iron Works.

NELSON®
Stud Welding

a cost-saving product of

GREGORY INDUSTRIES, INC.

LORAIN, OHIO



If glass is a chief
visual element in your
design, then the beauty
of that glass should be
a major concern in
your specification.

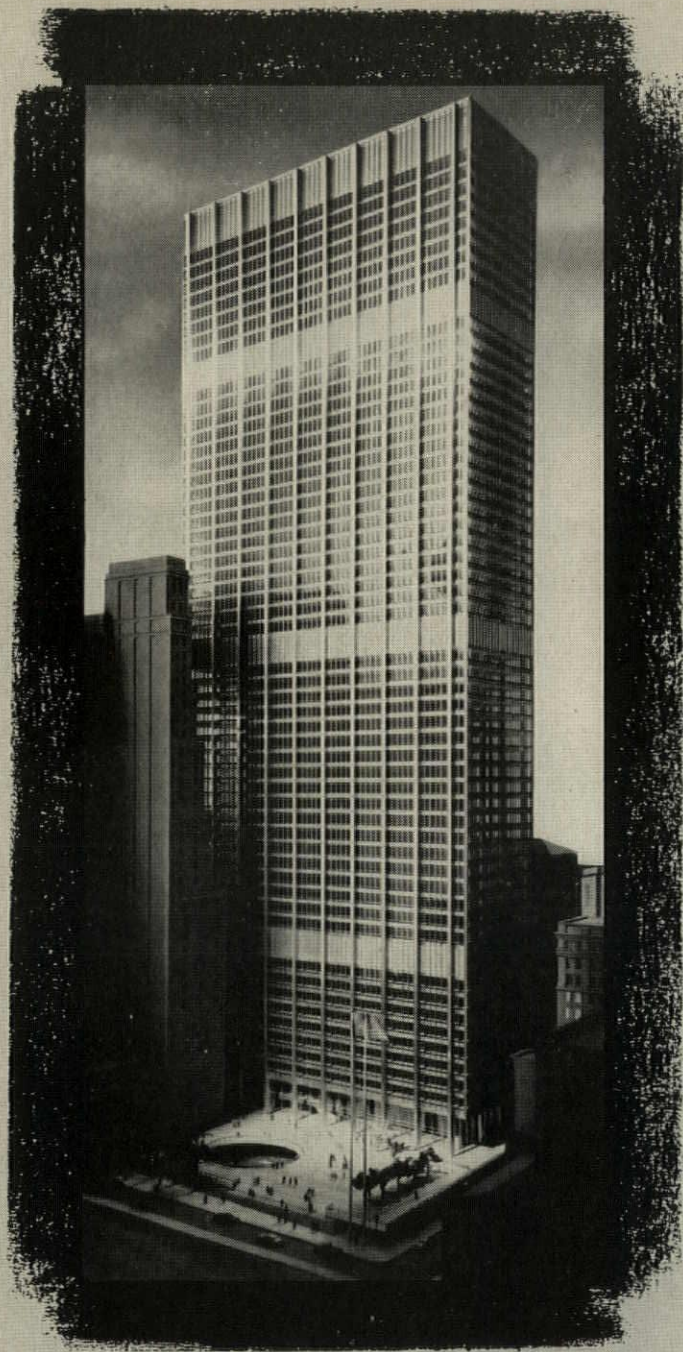

Beauty of glass is largely a matter of the reflections seen in it. Wiggly reflections—which mar beauty—are minimized with *plate* glass.

Twin-ground plate glass gives you the truest reflections. And you always get twin-ground plate glass when you specify L·O·F $\frac{1}{4}$ " *Parallel-O-Plate*® or *Parallel-O-Grey*®.

The Chase Manhattan Bank
head office building, New York.
Windows: L·O·F *Parallel-O-Plate* Glass.
Architects: Skidmore, Owings and Merrill,
New York.
General Contractor: Turner Construction Co.,
New York.



PARALLEL·O·PLATE GLASS

LIBBEY·OWENS·FORD GLASS CO. *a Great Name in Glass*

TOLEDO 3, OHIO



ON THE LEVEL... Why does a Westinghouse Elevator always glide to a perfect landing—softly, *without releveling*? The secret is hidden in a compact control worth its weight in gold—but you'll see it as "standard equipment" on the elevator system. Rototrol is its name and it's a Westinghouse exclusive.

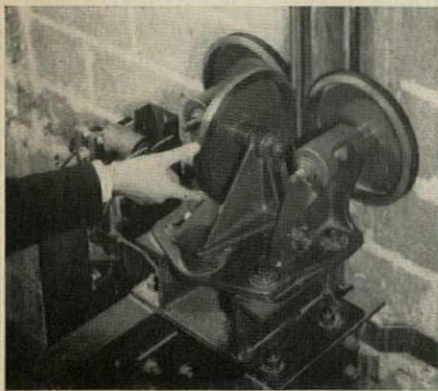

ROLLING ON RUBBER... Quiet elevators just don't *happen*—they're planned that way. You'll see how a Westinghouse Operatorless Elevator cushion-rides on rolling rubber, trapping vibration and noise. You'll see the cars operate on clean, *dry rails*—like an express train on rubber wheels.

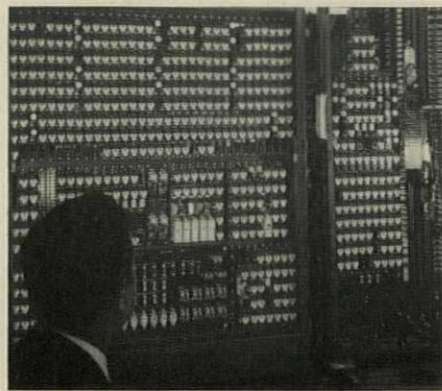

THE BRAIN ROOM... Your trip to the penthouse will reveal an electronic "brain," comprising computers, selectors and shuntless relays, that makes decisions every second. It supervises and directs elevator movement... dispatches elevators where and when they're needed. It's done instantly... automatically.

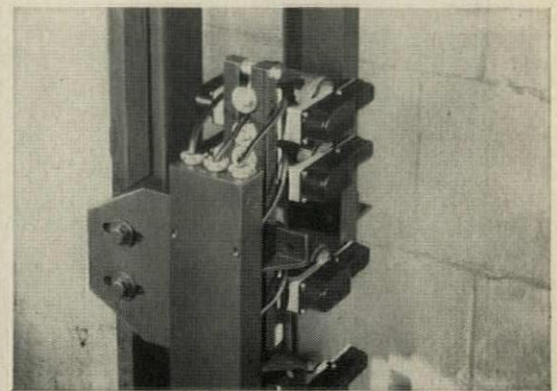

A MATTER OF INDUCTION... The "sinking stomach" is something you'll never experience in Westinghouse Operatorless Elevators. One of many devices built into the system that precludes such discomfort is this inductor on the elevator which controls slowdown and stop smoothly... accurately... quietly.

Westinghouse

*invites you to experience the
"30-Minute Pre-investment*

Eye-Opener"

JUDGE FOR YOURSELF THE BENEFITS OF WESTINGHOUSE OPERATORLESS ELEVATORS DURING THE BEHIND-THE-SCENES DEMONSTRATION

Westinghouse extends this special invitation to executives who are responsible for planning a *new* building or *modernizing* an existing one. In just 30 minutes, we can demonstrate technical advancements in modern elevating that will result in the efficient operation of your building, with complete tenant satisfaction, now and for the years to come.

Historically, the entire Westinghouse organization is electrically-oriented. Because of this, Westinghouse has brought to the elevator industry new control techniques

which have produced elevator systems of outstanding excellence. Westinghouse would appreciate the opportunity to show you this dramatic "eye-opener." Arrange to see this behind-the-scenes demonstration by calling the Westinghouse Elevator Division Sales Office in your city. Consult the Yellow Pages.

Typical preview highlights from the "30-Minute Pre-investment" demonstration are shown.



... MUCH TIME AND MONEY HAVE BEEN SAVED. "Our Engineering Staff experienced an actual demonstration of operatorless room service and freight elevators—and witnessed all the features Westinghouse builds into its system to satisfy the service needs of the Drake Hotel. With our new system in operation, we are particularly pleased with the manner in which the elevators speedily travel from floor to floor, eliminating long waits. Thoughtfulness of doors in their automatic opening and closing motion offers service personnel freedom of movement and elimination of anxiety while traffic is entering or leaving the car. As a result, guest service has been improved and much time and money have been saved in unnecessary delays."

Edwin L. Brashears, President
Drake Hotel, Chicago, Illinois

YOU CAN BE SURE...IF IT'S

Westinghouse

J-98779AA

Watch Westinghouse Lucille Ball-Desi Arnaz Shows CBS-TV alternate Fridays

WESTINGHOUSE ELEVATORS AND ELECTRIC STAIRWAYS

Drainage and Vent Lines in New York City's famous Seagram Building are galvanized steel pipe . . . durable and reliable steel pipe that will last the lifetime of the building and more with minimum service or maintenance.

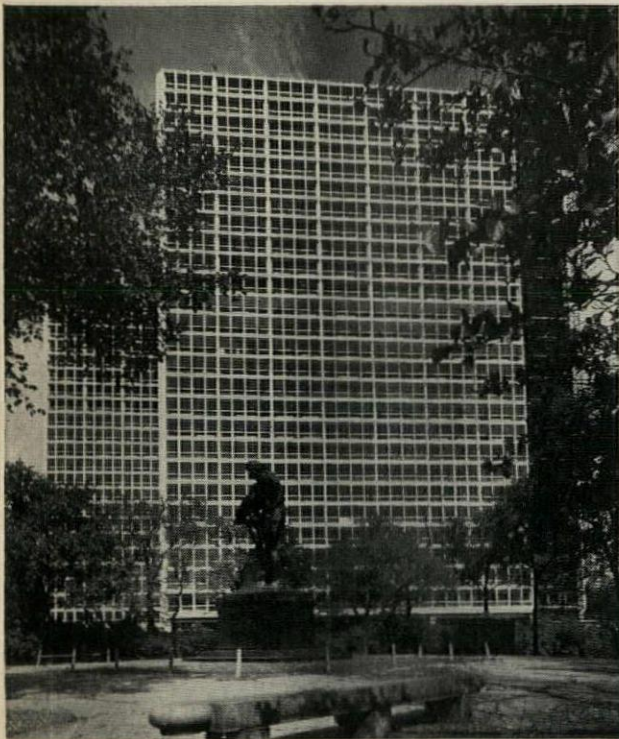

Rigid Steel Conduit safely and efficiently handles the electric power requirements of the Commonwealth Promenade Apartments in Chicago. Zinc coated steel conduit is used underground and in concrete, **black enamel** at grade level and above.



In the nation's buildings steel pipe does many jobs more efficiently, more easily, and at less cost

Accepted without question is the efficient and reliable performance of *steel pipe* in the nation's commercial, industrial and residential structures. And with reasons.

Design-wise—*steel pipe* fills many functions well, long and efficiently. Engineering-wise—it has the inherent strength and dimensional stability to withstand the toughest service over continued periods, and it is easy to form and join. Cost-wise—no

other metal tubular product offers more for less . . . ready availability, low initial cost, low installed cost and low per-year service cost.

These are only some of the reasons why *steel pipe* is the most widely specified pipe in the world for vent and drainage lines, heating and cooling, snow and ice melting, refrigeration and ice-making, fire protection systems, electrical conduit and structural uses, and water, steam, air and gas lines.



Sprinkler System and Stand-Pipe Fire Lines in Travelers Insurance Boston building are durable steel pipe. Savings in initial and installation costs were considerable; insurance premiums were less with steel pipe fire protection systems on guard throughout the structure.

STEEL PIPE IS FIRST CHOICE

- Low cost with durability
- Strength unexcelled for safety
- Formable—bends readily
- Weldable—easily, strongly
- Threads smoothly, cleanly
- Sound joints, welded or coupled
- Grades, finishes for all purposes
- Available everywhere*from stock

Insist on



Steel Pipe

COMMITTEE ON STEEL PIPE RESEARCH

150 East Forty-Second Street, New York 17, N.Y.

world, however, the operating companies do not have such an easy time. Telephone buildings are an increasingly bulky part of every U.S. city; and, ever since 1930, when the operator's so-called "voice with a smile" symbolizing the company "personality" began to be replaced by mechanical dial systems, A.T.&T. has realized that its buildings were an essential feature of its "personality."

Since then there has developed, in fact, an almost pathological concern about the appearance of its buildings. This concern has been a good thing for

U.S. architects. The operating companies are well-nigh the biggest and the steadiest customers architects have ever had. Last year, some 83 medium to large architectural firms, including those of every A.I.A. president from Ralph Walker on, did an almost constant run of telephone work. If all the architectural firms employed by the operating companies since the war were totaled, the number would exceed 250. Thus, if the architecture of the telephone building leaves something to be desired, part of the fault can be spread across the boards of U.S. architects.

Right now, A.T.&T.'s Building Engineer H. E. Phillips is quietly trying to do something about that. An architect himself, 47-year-old Phillips carries behind an impassive face a passionate conviction that A.T.&T. ought to have better architecture. "Some of the architects frequently employed," says Phillips, "are in the doldrums as far as telephone company work is concerned."

A share of the blame, A.T.&T. officials candidly admit, is also theirs. "I'm not sure," says Phillips' boss, Assistant Chief Engineer C. M. Mapes, "that we've always asked for the architectural excellence we ought to get."

Unfortunately, Phillips and his staff at 195 Broadway must be content to "sell" the notion of better architecture to the operating companies; they cannot, in the A.T.&T. way of doing things, "direct" it. The recent competition, the results of which are demonstrated on page 120, is the most earnest attempt to sell better architecture to date. But as the rather imperceptible differences drawn between honored and unhonored entries prove, *wanting* better architecture and *motivating* it (to use a favorite word at 195 Broadway) are two different things.

The stage sets

The difficulty is that all too rarely Bell System building engineers—and its commissioned architects—think of architecture as anything but skin deep. Most of the competition entries, for example, carried a comment by its architect and a review by A.T.&T.'s consulting architects, Voorhees, Walker, Smith, Smith, & Haines. One architect's comment, about his unsuccessful contender, went, unbelievably, like this: "Postwar construction costs dictated an economical design, and such was achieved with only a small amount of stone at the business office entrance." The enigmatic comment of the consulting architect was: "Modest landscaping might improve this design." To say the very least!

The trouble is that too often the architect's main contribution is merely considered a matter of stone trim or modest landscaping. But another trouble is that A.T.&T. knows so much about building that its architects have a hard time contributing more than

continued on page 225

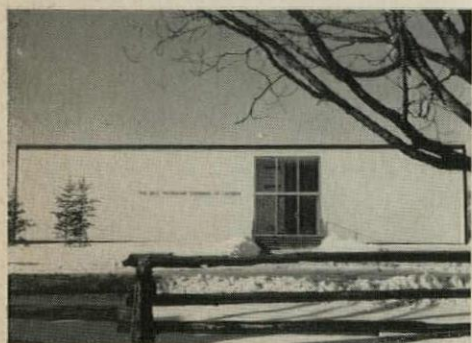
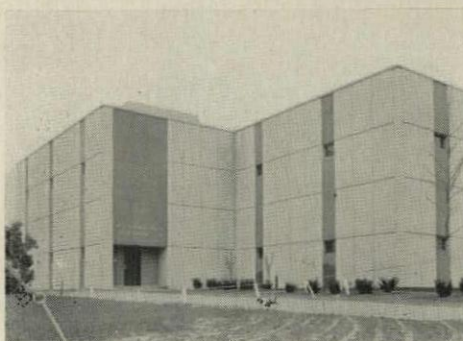

Continuity between the neighborhood and the telephone building obviously got the merest nod in two of the buildings above. One, pseudo-western, for Scottsdale, Ariz. (top), and another, pseudo-Colonial, for East Northport, L.I. (center), obtained stylistic front porches or colonial façades cut down until they are almost parodies. The frank grace of a similar but contemporary building in Pickering, Ont. (bottom) is far superior.

Inanimate massiveness is a characteristic of today's telephone building that is better faced than denied. The careful Colonial restoration in Staunton, Va. (top) belies its true use by the scrupulous care in which Venetian blinds are kept tightly closed. The frankly blocky structures in Southfield, Mich. (center), and Los Angeles, Calif. (bottom) are far superior, although both admittedly are somewhat grim in appearance.

A cluster of terraced units in a generous community park.

"The architectural character of San Francisco is expressed in buildings terraced to its hills: a closely knit complex of high retaining walls, introverted courts and alleys, which—apart from

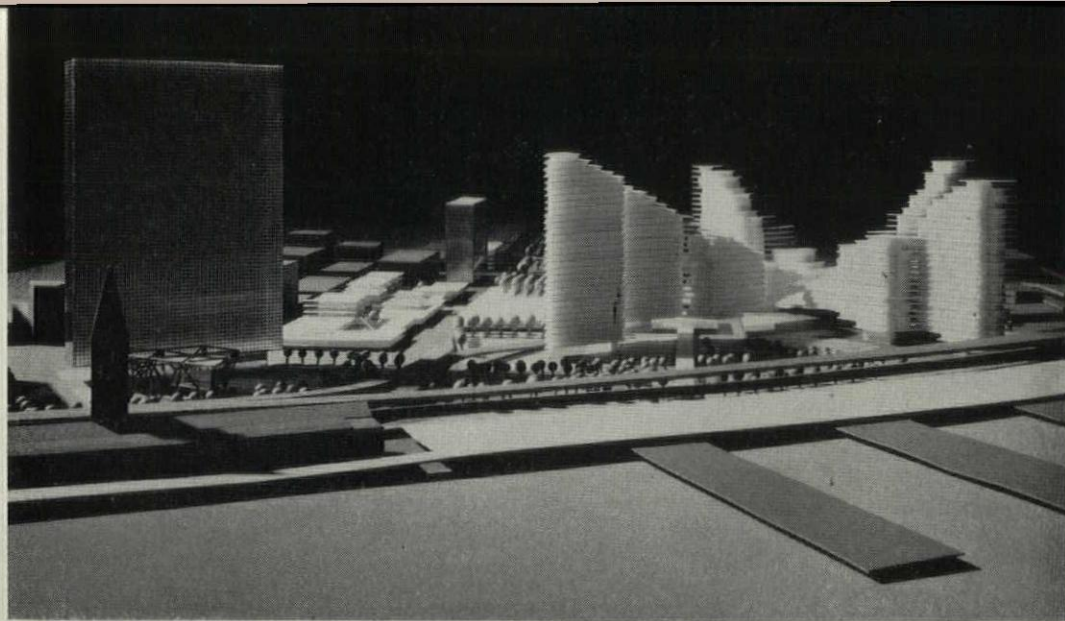

DWYER FAUBION

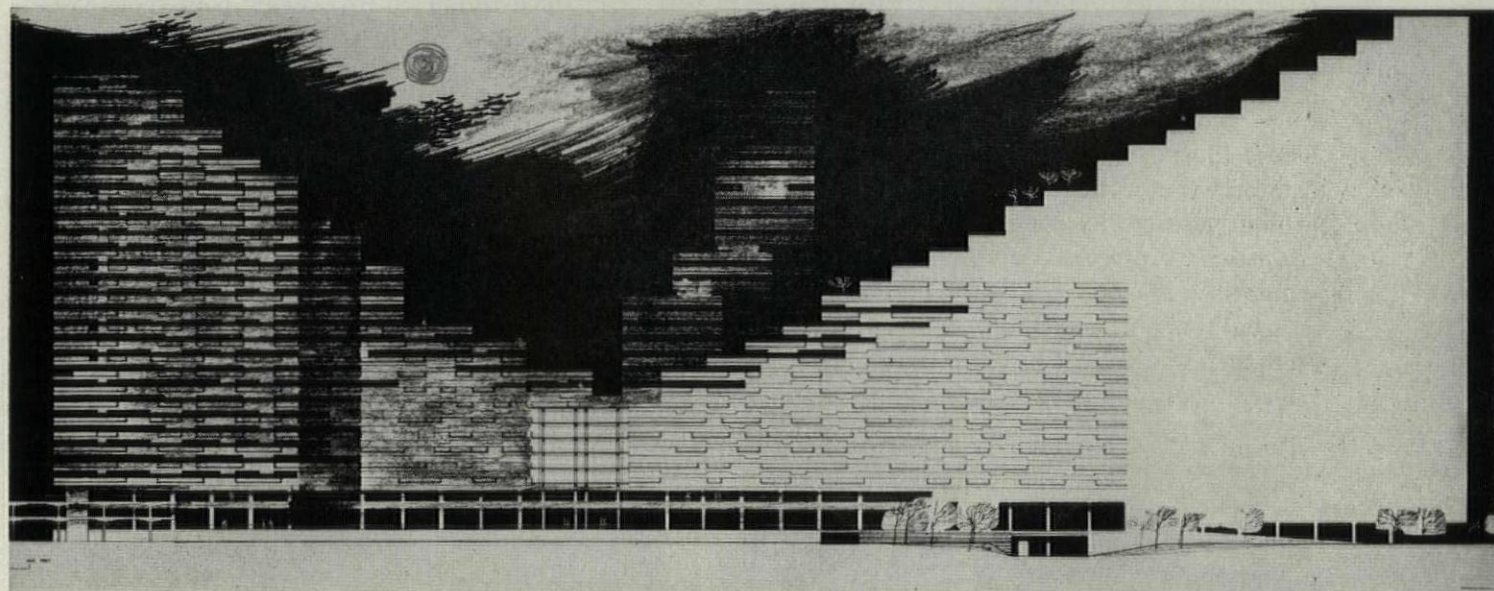

its axial plan—is reminiscent of the informal structure of southern European villages. The informality of these hill clusters provides a fertile background for individual expression.

"Against this background, our concept of Golden Gateway was in terms of 'clusters,' with a distinct structure providing the frame within which the living functions could develop freely. The residential area, the major cluster, was conceived on an axial plan, oriented for maximum views and sun, and arranged in stepped terraces linked by horizontal and vertical circulation. These terraces provide spaciousness and privacy yet retain a sense of community, and express in urban terms the 'California style of living.' By providing a link through to the proposed Ferry Park, we also hoped to open up to the public an urgently needed green space downtown."

DEVELOPERS: Sidney Leiken Enterprises and Theodore G. Meyer & Sons. ARCHITECTS: Jan Lubieznycz, John Collier, Philip Langley. END

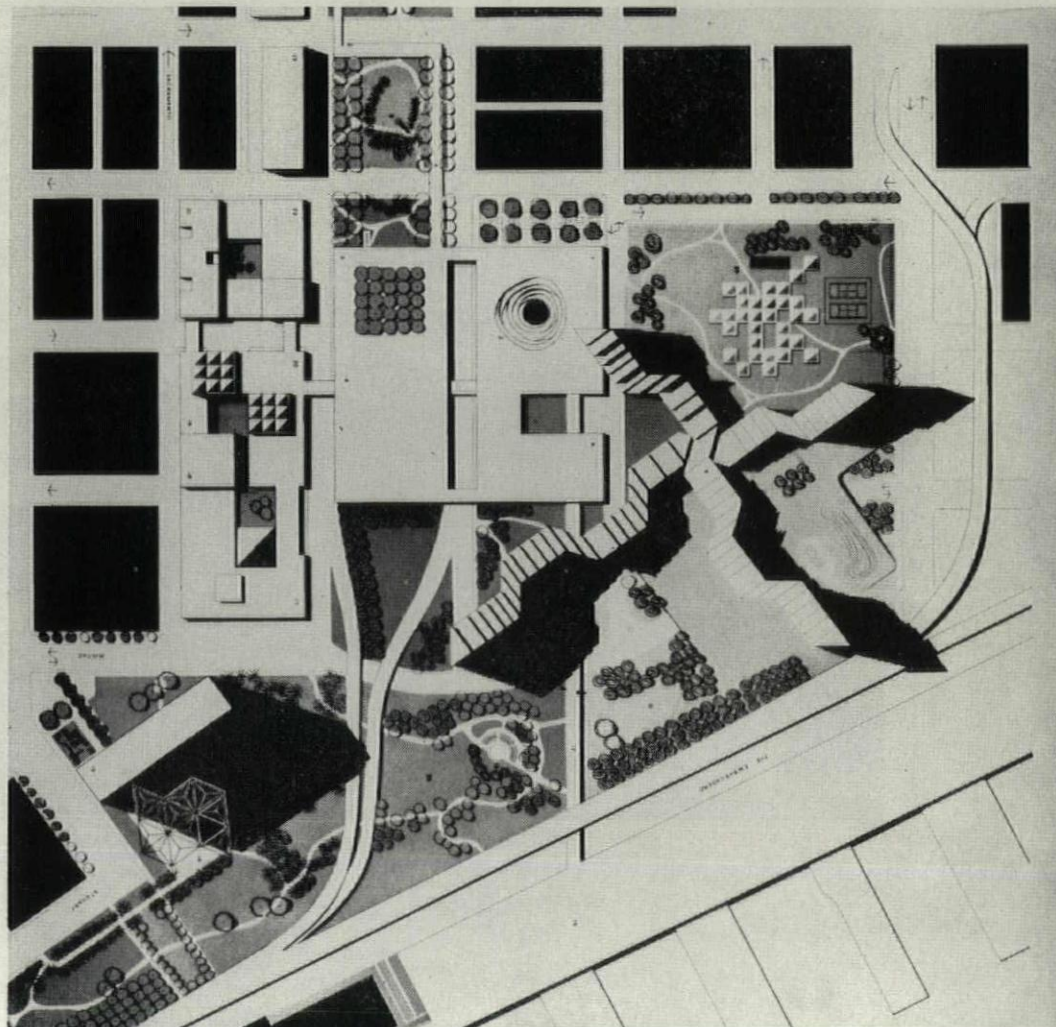

DESIGN WITH LUPTON

when you have a problem project, as they did at the University of Missouri

Administrators at the University of Missouri had a problem. They wanted to maintain a traditional "house" system in their new women's dormitories. But rising construction and maintenance costs called for much larger buildings.

Architects worked out a compromise by designing large dormitory buildings, each with four separate "house" units within. General facilities such as a social area, mail desk and office were centrally located.

These dormitory buildings and the centralized cafeteria that connects to each of them by underground passageway were built with 1,850 LUPTON "Master" Projected Aluminum Windows. These windows have both outward and inward opening ventilators for healthful, controlled ventilation. And their simple, uncluttered lines mean maximum natural light . . . easy cleaning.

Also, LUPTON "Master" Windows are lightweight

and accurately prefabricated for simple, economical installation. They're non-rusting . . . never need painting . . . exceedingly durable.

Most advantageous of all, though, is LUPTON's dependability. As proven in hundreds of jobs—including one of the largest curtain-wall installations in the world, Two Broadway, New York City—you can depend on LUPTON to meet your specifications, to deliver as scheduled. You can pinpoint responsibility because LUPTON can do the whole job—even install!

See SWEET's (Sections 3 and 17) for the Michael Flynn Aluminum Curtain Wall and Window catalogs, and write for further specific information. Inquire about LUPTON Comfort-Conditioning*—the new curtain wall system that cools, heats, and ventilates. A call to the nearest LUPTON representative (see the Yellow Pages under Windows—Metal) will bring fast action without obligation.

*Trade Mark

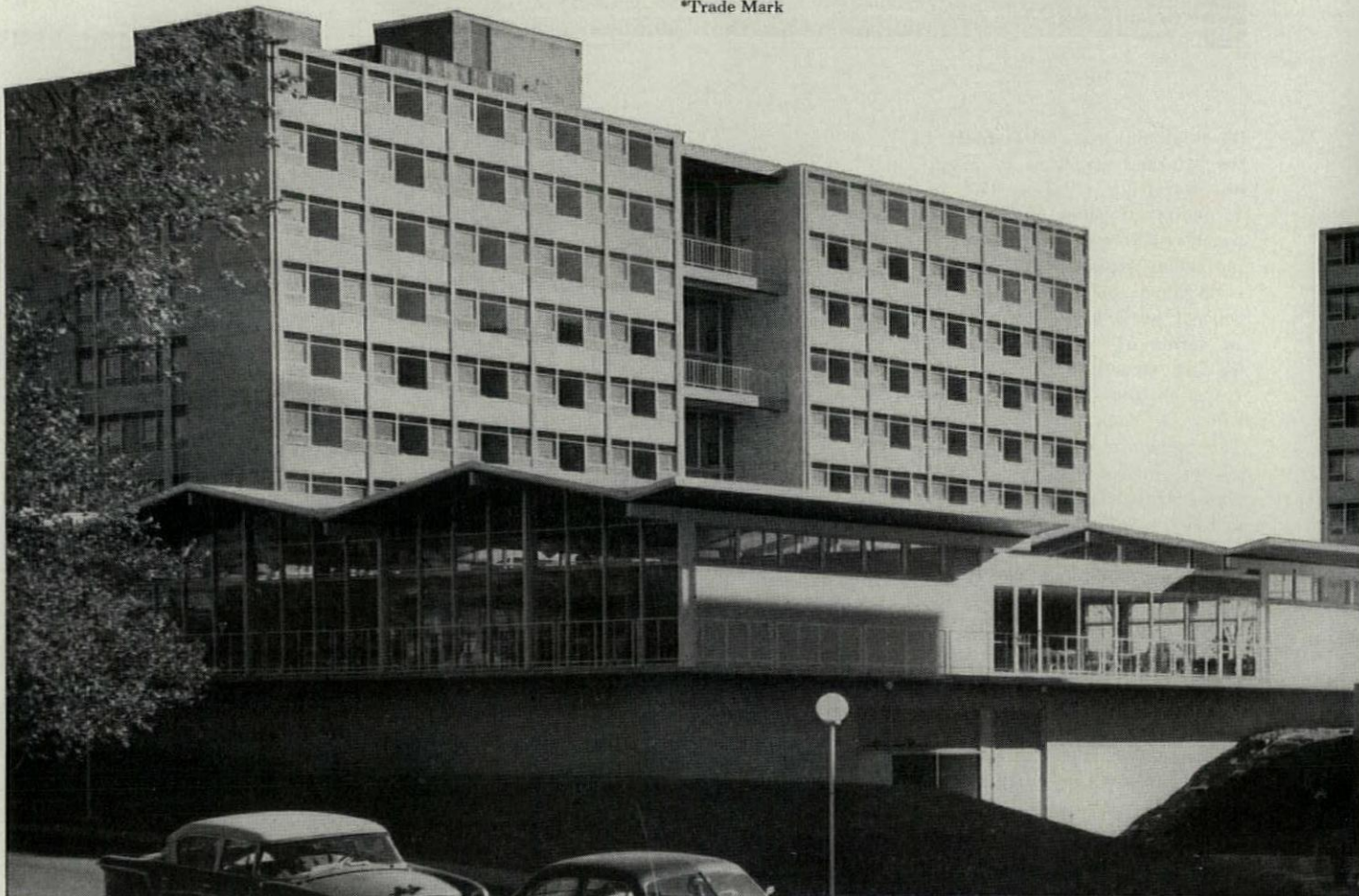

University of Missouri (Women's Dormitories and Cafeteria), Kentucky and Maryland Avenues, Columbia, Mo.

ALUMINUM WINDOWS

LUPTON[®]

**METAL WINDOWS • CURTAIN WALLS
MICHAEL FLYNN MANUFACTURING CO.**

Main Office & Plant: 700 E. Godfrey Ave., Philadelphia 24, Pa.; West Coast Plant: City of Industry, Calif. (Los Angeles County); Stockton, Calif.; Chicago, Ill.; New York, N.Y.; Cincinnati, Ohio; Cleveland, Ohio; Dallas, Texas. Representatives in other principal cities.



Architect: Hellmuth, Obata and Kassabaum, St. Louis, Mo. Contractor: D. C. Bass & Sons Construction Co., Bass Bldg., Enid, Okla.

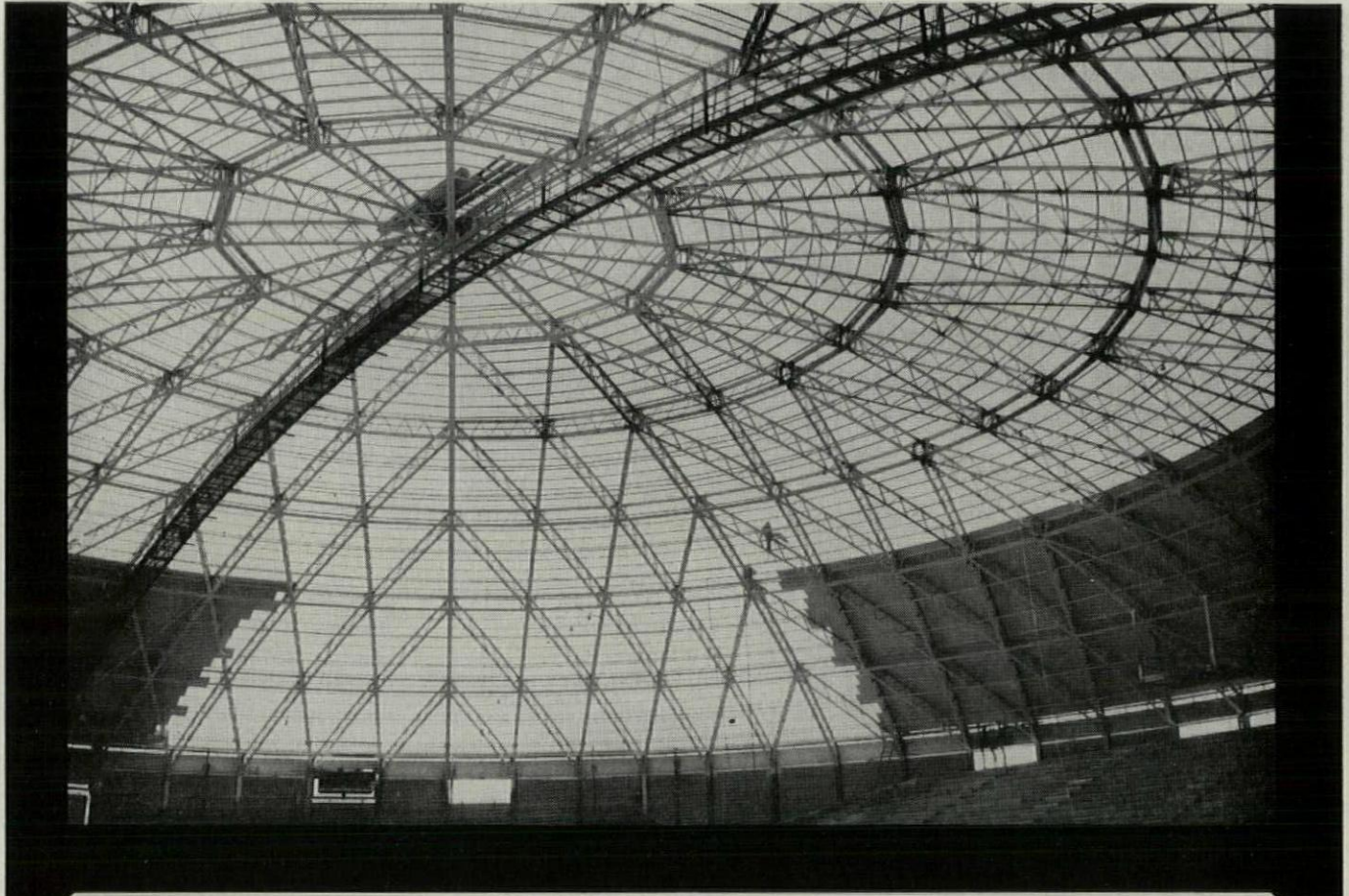

Note the clean, uncomplicated construction, the attractive architectural features, the enormous span.

*There's an Inland
Structural Steel
for every new
construction idea*

Domes making full use of the versatility of structural steel, easily span tremendous unobstructed areas—meet every requirement for ease and speed of erection, light weight, beauty and economy.

Prefabricated structural steel members are delivered to the site ready for immediate use. Erection is speedy and uncomplicated, with little field fabrication required. Ribs can be small trusses, light weight I-Beams or similar structurals. The light weight, self-supporting nature of such domes eliminates the need for the dead weight of heavy wall construction. Temporary steel columns support the compression ring during erection—eliminate expensive falsework.

For complete information on the considerable savings achieved on many steel domes, see your local fabricator who now has structural steel available in all shapes and sizes—or call the American Institute of Steel Construction office in your area.

Temporary supports of steel, easily salvagable, are used to support the trussed ribs during construction.

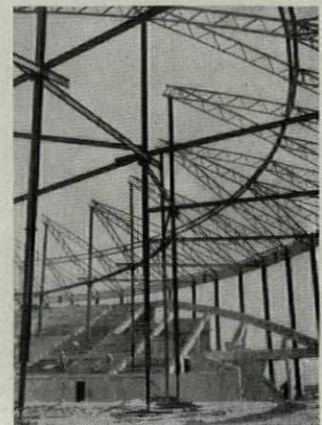

Use  For Modern Construction

other Inland construction products

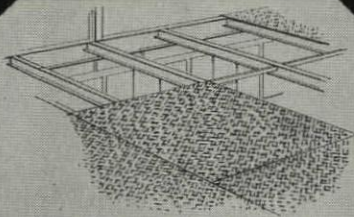

4-WAY SAFETY PLATE has come into general use as an integral, prefabricated part of the supporting structure, providing durable floors and added strength.

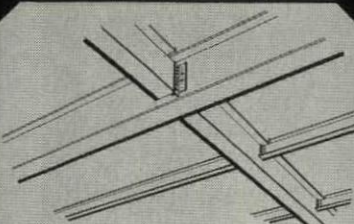

WIDE FLANGE BEAMS are the answer wherever more strength with less weight, longer spans with more open floor area, is the goal. Sizes from 8' to 24'.

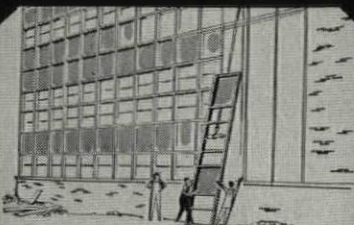

INLAND ENAMELING IRON is ideally suited to curtain-wall and enameled panel systems, providing strength, beauty and unlimited design possibilities.

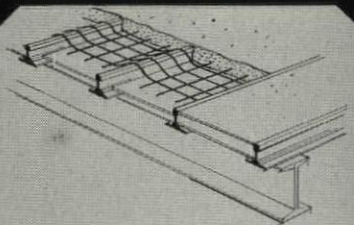

INLAND SUB-PURLINS are especially designed to provide a lighter, more efficient member for shorter-span roofs. They come cut-to-length and mill painted.



INLAND STEEL CO.
30 West Monroe Street
Chicago 3, Illinois

ideas about such things as trim and landscaping. The building engineers, with the efficient help of Phillips and his staff, have developed a truly impressive, systematized, and entrenched knowledge of telephone building. This knowledge not only covers the typical areas of building cost, details, materials, structural solutions, and maintenance standards (to such a degree that some architects have said that A.T.&T.'s buildings were designed for the janitor); it also includes the complex and parochial knowledge of telephone equipment and how to fit it into a structure.

Nearly 40 per cent of the Bell System's 130 million square feet of building floor space is, in fact, occupied by equipment. With each year, the ratio increases. As automatic equipment moves from research at Bell Labs, through development and production at Western Electric, to installation in cities and towns all over the U.S., the building problem becomes more rigidly constricted, more tightly a matter of carefully fitting equipment into system-wide standard bays. Small equipment buildings, called community dial offices and radio and repeater stations (which are not buildings in the conventional sense at all), are now usually completely unattended. Large equipment buildings, including new long-lines toll buildings, may have some office space, but they are designed to house equipment exclusively in the indefinite future when the human employees will be replaced by automatic equipment. For example, high-speed accounting machines are already installed in some 200 locations. Soon the only buildings that may be left to house people are administrative offices, garages, and work centers.

Obviously, from a functional point of view, A.T.&T. hardly needs architecture at all—at least, as it currently understands architecture. There remains, though, an intense concern about the Bell System's impression on the public. More and more, the "look" of the telephone company—its corporate image—is an important factor in the relations between company and public, especially since the government's anti-trust suit in 1948.

For many years, A.T.&T. has sought

its image in simple identification with the local community. If, for example, a building was to be built in New England, it was Colonial. If the building was on a residential street, it was disguised as a house. In the last few years, however, several changes have affected this policy, not the least of which has been the increasing acceptance of modern architecture.

This acceptance is all to the good, but while the operating companies have been timorously approaching modern architecture, they have enthusiastically embraced another notion disastrous to the cause of architecture: that because A.T.&T. is a public utility its buildings must not only be economical, they must decidedly look so. This attitude, when it appears in a traditional building (leaving vestigial corner quoins and tile roofs—see page 218), is obviously a disaster. Unfor-

continued on page 228

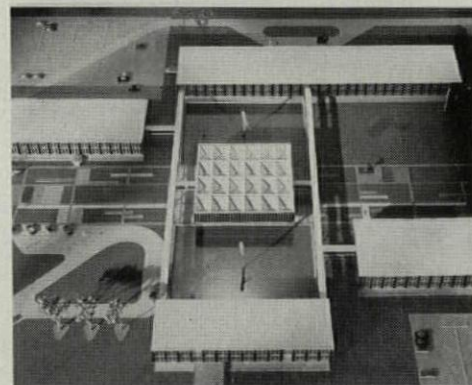
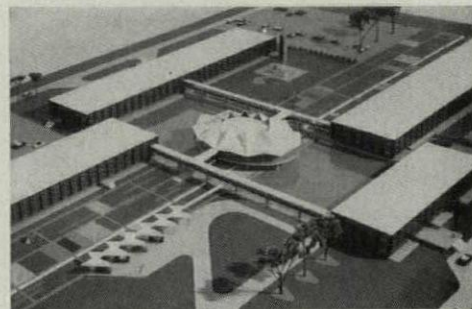

Michigan Bell's Northwest Staff Center, one unit of which is already built near Detroit's Northland Center, marks a hopeful new trend from too-conservative design. It was designed by Architects Smith, Hinchman & Grylls Associates with an elliptical service building in the center (model photo, above, top). After review by A.T.&T. and its consulting architects, a revised design (model photo, above) used a quieter, square structure. The Center is one of the first moves to decentralize Michigan office operations.

An Outstanding Achievement...
in modern design, engineering and construction



NEWARK AIRPORT, CONTROL TOWER
NEWARK, NEW JERSEY
OWNER: NEW YORK PORT OF AUTHORITY
ARCHITECT: A. GORDON LORIMER,
NEW YORK CITY
STRUCTURAL ENGINEERS: STROBEL & RONGVED,
NEW YORK CITY
CONTRACTOR: CARL BUHR, INC.
NEW YORK CITY

Bayley CURTAIN-WALL A-450 SYSTEM
With Kalwall Plastic Panels

The WILLIAM BAYLEY Co.
Springfield, Ohio
Agents in All Principal Cities

SPRINGFIELD, OHIO
1200 WARDER ST.
FAirfax 5-7301

District Sales Offices:
NEW YORK 17, N. Y.
GRAND CENTRAL TERMINAL
MUrray Hill 5-6180

CHICAGO 2, ILL.
105 W. MADISON ST.
RAndolph 6-5997

WASHINGTON 5, D. C.
1426 "G" ST., N.W.
STerling 3-3175

ORIGINATORS • DESIGNERS • MANUFACTURERS • INSTALLERS



THIS KEY WORKS ... UNTIL YOU USE THIS ONE!

Unique New Russwin Construction Key* System offers quick, easy way to insure building security!

No lock cylinders to change! Simply turn a key to introduce permanent key system

One set of keys operates locksets during building construction. Another set is issued after work is completed. *Initial use of this second set automatically cancels out the first set!* No lock cylinders to change. Security is insured with the turn of a key when permanent key system is introduced.

The unique Russwin Construction Key System offers the simplest, quickest, most practical way to provide protection and peace of mind for *any* building owner. Have your Russwin hardware consultant demonstrate this remarkable new development. Or write for details to Russell & Erwin Division, The American Hardware Corporation, New Britain, Connecticut.

*Pat. appl'd. for



KEEP YOUR EMPLOYEES...

ON THE LEVEL!

With a
**LAMSON SELECTIVE
VERTICAL CONVEYOR**



Simple — dial any floor

Granted, a pretty girl is like a melody. But let one drift around a multi-story building delivering papers and you have a pretty tired girl as well as a pretty expensive messenger.

Multiply this girl by all others in your office building and you'll readily understand the great need for a less costly and more efficient inter-floor light materials handling system.

LAMSON engineers have designed a very successful one, the **SELECTIVE VERTICAL CONVEYOR** — a continuous chain lift capable of servicing all floors, receiving and discharging tray-loads of material *automatically!*

Users report that enough savings result from reduced messenger expense plus more efficient time-use of productive employees to amortize the complete cost of a LAMSON SELECTIVE VERTICAL CONVEYOR.

Why not find out more about it? Write today for a LAMSON catalog containing full information about Selective Vertical Conveyors, Clinical History Lifts and Book-veyors. Or, simply clip this advertisement to your letterhead and mail to:



LAMSON CORPORATION

412 Lamson Street, Syracuse 1, N. Y.

PLANTS IN SYRACUSE AND SAN FRANCISCO
OFFICES IN ALL PRINCIPAL CITIES

A.T.&T.'S ARCHITECTURE

continued from page 225

tunately, most of the contemporary designs seem to suffer from this attitude too.

One point in favor of modern architecture could obviously be a blessing to A.T.&T.'s buildings: in a sealed, uninhabited equipment area, windows are unnecessary, and only modern architecture gives freedom from fenestration by rules. This opportunity, however, has rarely been exercised to date. An equipment building need not be more than an enclosing masonry surface, a backdrop, perhaps, for an articulated office wing or even for a civic open space. Indeed, with civic open space so rare, how better could A.T.&T. show its civic spirit than by putting its equipment *under* a new city square?

Perhaps the most difficult part of finding a corporate image for the Bell System building is to link the image with the real functional needs of the buildings themselves. They are necessarily massive, and they are getting more so. They are impersonal—also of necessity. At the moment, too many A.T.&T. buildings try to convey an image of grace in the manner of the elephant that tried to look graceful by draping a lace handkerchief on her back. Architecture, in the profoundest sense, is no mere "lace handkerchief" on a structure, and A.T.&T.'s corporate image need not adopt such a pathetic ruse. There is, after all, the magic and wonder of the world's most advanced communication network still to express.

Architects for the buildings illustrated (from left to right, top to bottom): Page 120: Tinsley, Higgins, Lighter & Lyon; Grassold-Johnson & Associates; Marani & Morris; Wallace & Burrill, Inc.; Voorhees, Walker, Foley and Smith; Edward J. Thias; Charles E. King; Harold Spitznagel & Associates; Tibbals-Crumley-Musson; Shaughnessey & Bower; Bellman, Gillett & Richards; Holabird & Root; Emil A. Schmidlin; Ray Hellmann; Hugill, Blatherwick, Fritzel & Kroeger; Tinsley, Higgins, Lighter & Lyon; Warren, Knight & Davis; Alonzo J. Harriman; Maurice Fletcher; Woodford & Bernard. Page 122: Shreve, Lamb & Harmon, Associates; Voorhees, Walker, Foley & Smith and Western Electric Co., Inc.; Eero Saarinen & Associates. Page 218: Lescher & Mahoney; Merrill C. Lee; Voorhees, Walker, Smith, Smith & Haines; Smith, Hinchman & Grylls Associates, Inc.; G. S. Adamson & Associates; Woodford & Bernard. Page 225: Smith, Hinchman & Grylls Associates, Inc.

PHOTO CREDITS: Frank P. Adams; J. W. Brown; Walter S. Craig; P. A. Dearborn; Robert De Long; Dementt Studio; Gitta Photo; Greg's Studio & Kamra Shop; Harold's; Hiatt Photo Service; Cortlandt V. D. Hubbard; L. D. Jones; Keyport, N. J.; Baltazar Korab; Lazarnick Steinberg; Ira Wright Martin; Michigan Bell Tel. Co.; Mac Mizuki; Mound Photographers; Pickering-Ajax; Sybenga Studio; Tyler Studio, Des Moines; Western Electric.

END

MECHANIZE... PROFIT-WISE!

WITH A
**LAMSON AUTOMATIC
AIRTUBE SYSTEM**



Station to station service.
Carriers have built-in
memory.

Orders, invoices, records, punch cards, blueprints, samples, inter-office memos, mail . . .

Everyone complains about mounting paperwork that slows production, increases overhead, cuts profits, ruffles tempers.

Now, you can do something about it . . . put your paper in the air via LAMSON'S AUTOMATIC AIR-TUBE SYSTEM. Delivery is assured 24 hours a day in a matter of seconds . . . automatically!

Increased efficiency is so dramatic that the entire cost can be amortized out of annual savings. After that, you enjoy the benefits of LAMSON AIRTUBE almost cost-free for years to come.

This is why you find more LAMSON AIRTUBE SYSTEMS in operation than any other kind.

Write LAMSON for informative catalog today. Or, simply clip this advertisement to your letterhead and mail to:



LAMSON CORPORATION

412 Lamson Street, Syracuse 1, N. Y.

PLANTS IN SYRACUSE AND SAN FRANCISCO
OFFICES IN ALL PRINCIPAL CITIES

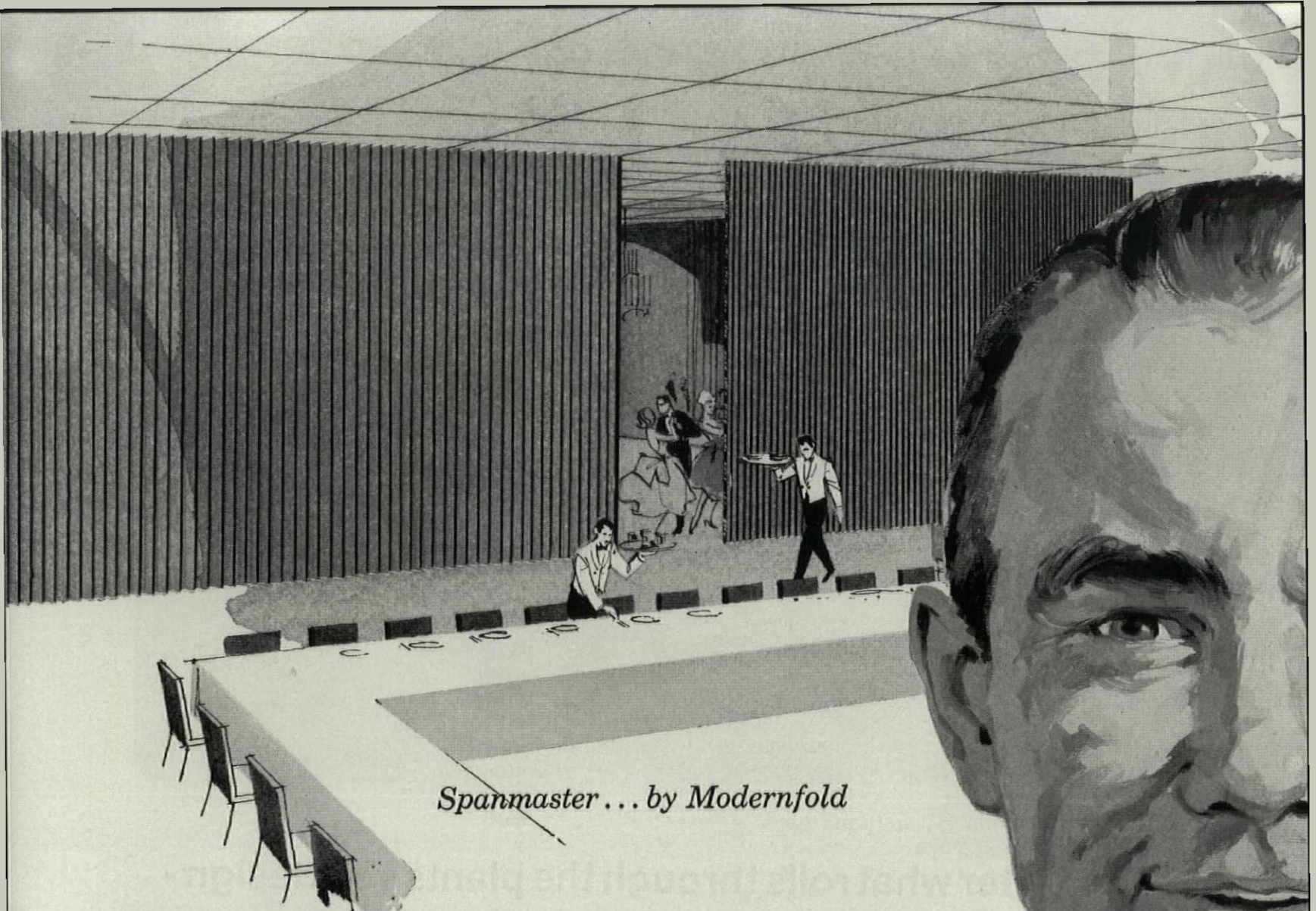

Spanmaster... by Modernfold

Only Modernfold goes to this length with double-truss strength

● The exclusive Modernfold twin hinge, plus overall heavier construction, is your guarantee that the new Spanmaster more than masters the stresses and weights a king-sized installation imposes.

In short, you no longer need to gamble . . . hoping a construction adequate on small jobs will work on big ones. Specify Spanmaster . . . by Modernfold. And get the bonus of a Class A fire rating . . . another Modernfold exclusive.

Get the specifics on Spanmaster now. Call your Modernfold Man. He's listed in the yellow pages, under "Doors, Folding." Or, write for the booklet, "Folding Partitions."

NEW CASTLE PRODUCTS, INC., NEW CASTLE, INDIANA
 In Canada: New Castle Products Canada, Ltd., St. Lambert, Que.

On all Spanmaster partitions over 15'0" high, you get this *double-truss* suspension for super strength and smooth action.

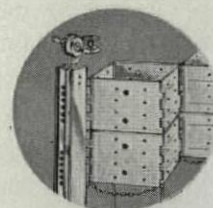

All-steel trolley glides on ball bearings . . . sends the biggest partitions skimming down the track like little ones.

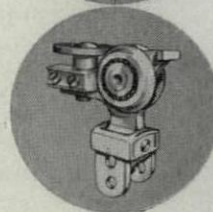

Folding partitions for every need . . . every budget

From standard to giant-sized . . . from thrifty to luxurious . . . Modernfold has the door, divider or partition that answers your specific requirements. Choose from up to 60 vinyl fabric coverings in the steel framework models . . . or from the selection of rich wood finishes.

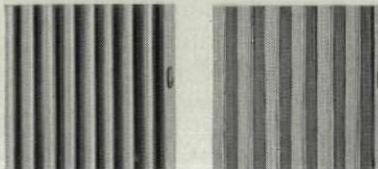

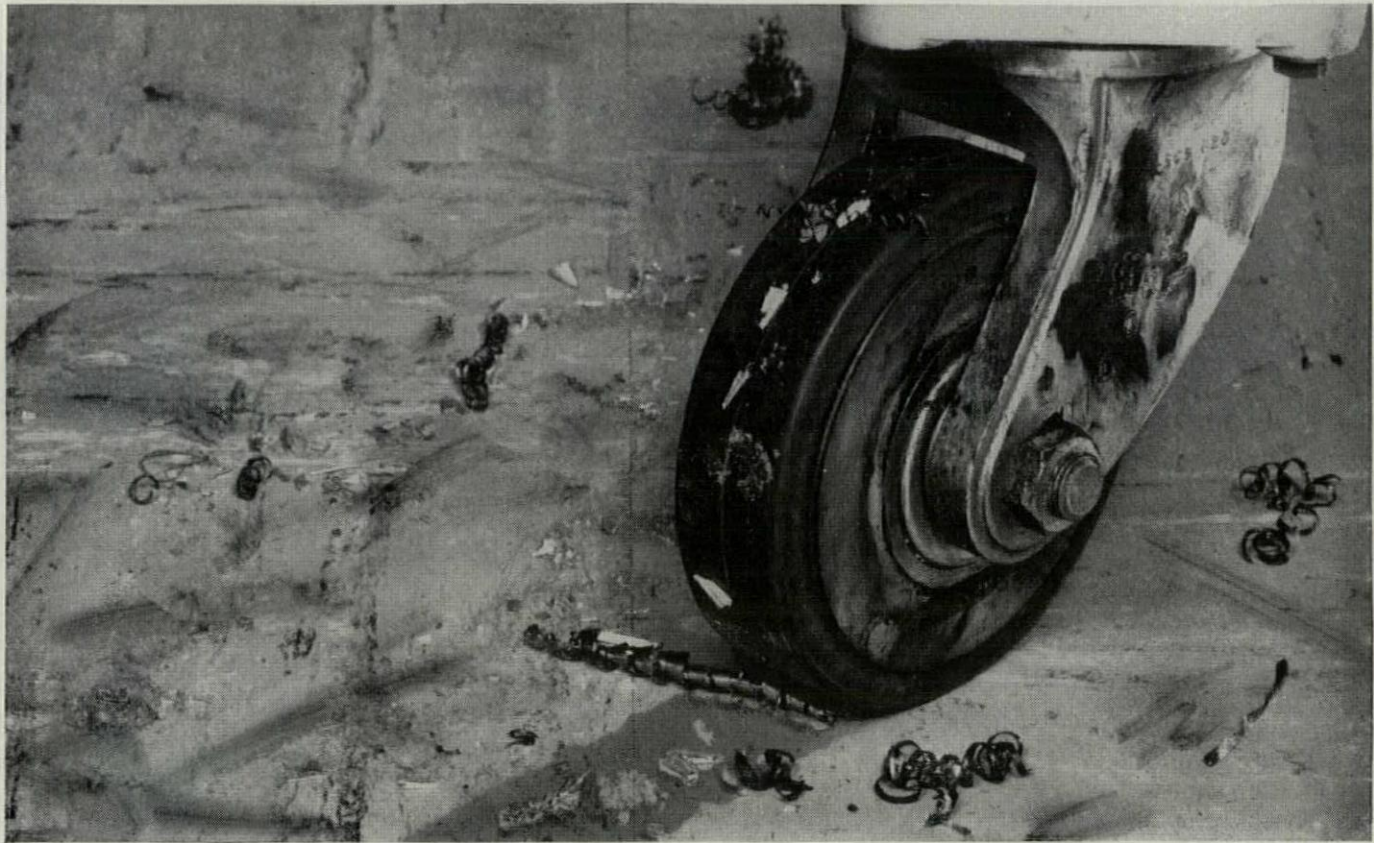

Flintkote salesman Bill Schrand says...

"No matter what rolls through the plants you design—Flintkote's new Super Tuff-Tex® floor tile can take it!"



"There's no doubt about one thing: an attractively designed plant means a more efficient plant. And an important part of design is handsome, but rugged, floors.

"Here's where Flintkote's Tuff-Tex floor tile has come to the aid of many industrial architects and designers for many years. Tuff-Tex was developed specifically for industrial use. And it has stood the toughest tests over and over again. New Super Tuff-Tex is even better. It is a heavy-duty tile, strengthened with Asbestos — nature's permanent fiber. As a result, these tiles have greater strength—can shrug off plant traffic, including an amazing amount of trucking abuse—and roll with

the punches from dropped objects.

"As for upkeep, Super Tuff-Tex is greaseproof, withstands oil, too. Its close-textured surface makes maintenance easier and economical. And, of course, Super Tuff-Tex is fire resistant.

"What about good looks? This year, Flintkote is introducing eight new, attractive colors. As you would expect from Super Tuff-Tex, the colors and marbleization go all the way through the tile, for long lasting beauty in your plant."

For particulars and literature, see your local Flintkote Flooring Contractor. You'll find him a great guy to work with . . . and he knows his stuff in flooring materials.

The Flintkote Company
Flooring Division
30 Rockefeller Plaza
New York 20, New York



TILE-TEX PRODUCTS

**Now Available for
1960 SCHOOL PROJECTS**

- New Construction
- Renovation

THE LEXINGTON

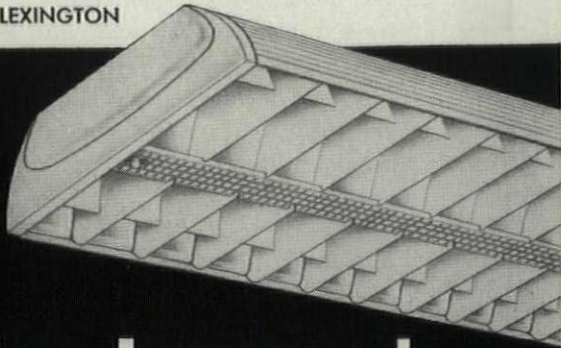

**New Improved
RICHMOND
and LEXINGTON
...at New Low Prices**

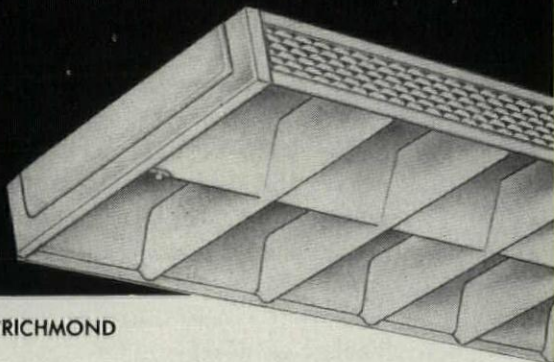

THE RICHMOND

The newly Improved Richmond and Lexington Series by Miller offer outstanding Values for lighting Schools, Offices, and Stores.

Four exclusive *installation and maintenance features* have been built into all units in both series. *Prices for most types are at new lows*, while illumination performance remains high as ever. Trimmer, more modern appearance is another plus.

You can choose between 45° x 45° or 35° x 25° shielding for both series; 2 or 4 Lp., in 4 or 8 foot lengths. *Power-Groove* operation is a brand new option for the 2 Lp. Richmond.

For complete catalog information mail coupon or write Dept. RL 460. For a physical demonstration contact your Miller Representative, or your Miller Distributor.

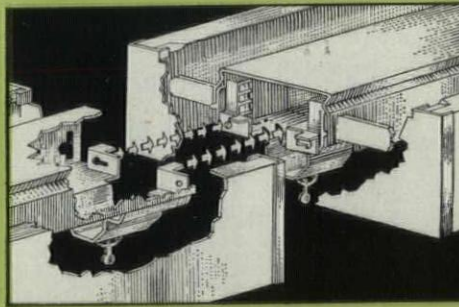

Sure Alignment . . .
Built-in Connector

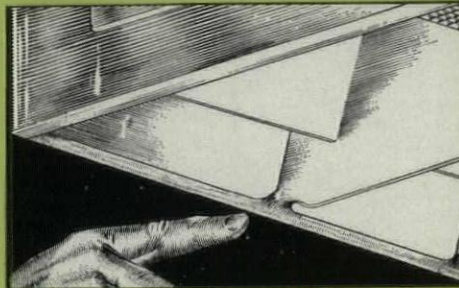

Rigid, Rattle-free
Shielding Assembly

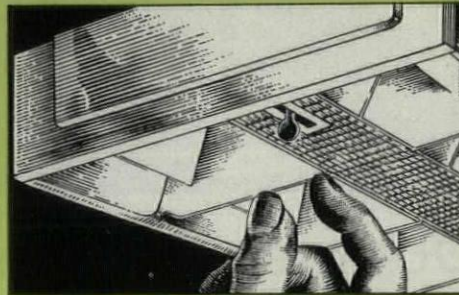

Sure Locking, Visual
Action Latches



Easily Relamped from Single Ladder Position

MAIL TODAY

To: Dept. RL-460
THE MILLER COMPANY, Meriden, Conn.

- I'd like additional information about The New, Improved RICHMOND & LEXINGTON Lighting Fixtures.
- Have Your Field Representative contact me.

Name..... Position.....

Company.....

Street.....

City..... State.....

LIGHTING BY
Miller
SINCE 1844

THE miller COMPANY
MERIDEN, CONNECTICUT • UTICA, OHIO



Here Is Double Protection For Masonry Walls

BLOK-JOINT For Control Joints
BLOK-MESH Deep Swedged Reinforcing

BLOK-JOINT is the cross shaped rubber extrusion for making fast, low cost control joints. It's used with ordinary metal sash blocks. There is no need for special blocks, building paper or mortar fill. It can be used in single block walls, with brick and block backup and at columns and pilasters. This time saving control joint forms a secure interlock that gives lateral stability and provides for *both* contraction and expansion in the wall.

BLOK-MESH is the "deep swedged" masonry reinforcing that gives additional strength and resistance to cracking. Its large, squared deformations allow the mortar to take a deep grip for maximum bond. Use both **BLOK-JOINT** and **BLOK-MESH** for maximum protection of masonry walls.



Pat. No. 2,869,356



BLOK-JOINT For Control Joints Made of "100 year life" rubber to meet ASTM and FEDERAL specifications. Comes in four lengths—8", 24", 48" and 50 foot rolls.

BLOK-MESH "Deep Swedged" Reinforcing. Large, well defined, squared notches to give a deeper, stronger mortar grip. No sharp edges to irritate hands. Butt welded to lay flat. Cuts and bends easily.

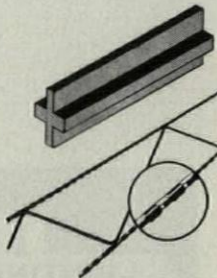

Arch. File Indus. File

4h

4c

Car

Car



Write for FREE Sample
and Specifications

Available in the U.S. through Concrete Block Manufacturers and Building Materials Dealers. Distributed in Canada by Consolidated Concrete Industries, Ltd., 9th Ave. & 24th St., East Calgary, Alberta, Canada.

BLOK-JOINT and **BLOK-MESH** are products of the Carter-Waters Corp., 2440 Pennway, Kansas City 8, Missouri, Dept. AF

Swig proposes to plunk on a corner of the noble old Fairmont Hotel; it will irreparably mar the scale and mood of the massive granite pile. In some ways the most interesting should be the ingenious combination hotel-motel, built around a garage, which William Tabler has devised for Conrad Hilton.

With luck, as many as 50 major structures will go up during the coming decade, including those in Golden Gateway. What makes the whole, roaring boom fascinating is that, although laissez-faire prevails in most cases and economic motives predominate, an imaginative planner could not have picked more logical sites for most of the buildings that are being erected. They are admirably spaced from the water front to the civic center in spots that are ripe for renewal. The Hilton Hotel, plaza, and adjoining office building, for example, will occupy a full block in the sleazy Tenderloin, where land was cheap, but will be within easy walking distance of both the smart shops and theaters around Union Square and the civic center where conventions are held. The magnitude of the \$35 million undertaking promises to improve the entire vicinity; and chic restaurants are already installing themselves nearby.

The city is on the move. Throughout downtown demolition and construction are under way. If much is architecturally disappointing, or worse, there are compensations in the very fact of newness, and amenities such as trees and planting. Welton Becket's Bethlehem Steel Building, just below John Hancock on California Street, is clearly outclassed by its splendid neighbor. Bethlehem's dark gray tile exteriors, brightened with white and stainless steel, manage to look garish rather than dignified, at least in contrast to the strength and sobriety of Hancock's granite. But the building has its greenery, and a charming roof garden by Royston, Hanamoto & Mayers, complete with waterfall. And again, there is the outlook on the city.

A challenge for architects

Everywhere, as San Francisco moves on its hills, swept over crest after crest by the resolute grid of streets, its

character changes. So does the language, color, and dress of the people—and the weather, when portions of the city are covered by fog blowing through the Gate, and the rest remains in the sun. The city is subtle. The architect can only try to capture its nuances, as Frank Lloyd Wright did in the V. C. Morris Store in Maiden Lane, in the days before the ugly little street was overpublicized, overpraised, and overdecorated.

On the other hand, the architect can try to capture the totality of the city's romance. Now beginning to rise on the slope of Nob Hill is a tower which may do just that. Anshen & Allen's American President Lines Building will be a glittering shaft of white and gold, capped by a bright hovering roof that should shine for miles in the sunlight, across the bay.

On the shores of the vast harbor, which until a few years ago were dotted with isolated towns and villages, there now extends a continuous urban strip, gradually broadening as subdivisions mount the hills. Population is growing at the rate of nearly 15,000 a month so that in a generation it will have doubled, and stand at 7 million. Socially, economically, and geographically the region is an entity; and, although it remains a political mosaic of 83 municipalities and nine counties, area-wide cooperation has already been achieved in smog-control and water-pollution agencies, as well as in the rapid-transit district which next year will ask the voters to approve an outlay of more than \$500 million for the first phase of a system which alone can liberate the region from the tyranny of the automobile.

At the center of this great metropolitan complex, giving it heart and cultural meaning, is San Francisco—"The City," as Manhattan is also called by Greater New York. Yet there the comparison must end. For if Manhattan has been rendered increasingly uninhabitable by insane congestion and Brobdingnagian scale, "The City" of San Francisco remains an uncommonly delightful place to live for its relatively stable population of 800,000. As they build, and gain the wisdom to plan, these San Franciscans are preparing for a period of greatness. **END**

use your foot to wash your hands



● A touch on the Bradley Foot-Control and you have a clean spray of tempered water for the best wash-up you've ever experienced! No soiled hot and cold faucets to touch. No dirty bowl because the Bradley rinses itself clean when it's used.

Yes, this is the Ultimate in washing pleasure, convenience, speed, sanitation and in modern good looks.

Bradleys are available in six beautiful colors, in any combination of these colors, and in stainless steel. Bradleys are ideal for today's schools, institutions, office buildings, plants and are already in use in many of the finest!

BRADLEY WASHFOUNTAIN CO.
2235 West Michigan St.
Milwaukee 1, Wis.



Write for
colorful new
Bradley Bulletin
K 1204



BRADLEY

washfountains



The Lennox Living Laboratory: This \$50,000 school has been built by Lennox Industries, Inc. in Des Moines, Iowa to carry on research in the field of school classroom heating, ventilating and air conditioning. Extensive research and testing is carried on continuously, both with and without students present in the classrooms.

GAS *and*
LENNOX *can*
provide your schools with the
finest in fresh air heating and
ventilating...

at lower operating and building costs

This new Gas system automatically draws in fresh air from outside . . . warms, cleans, and circulates air quietly and evenly throughout the school.

It's hard to believe, yet 65¢ per square foot was the complete cost of installing a Gas-fired Lennox Comfort Curtain System in the Potosi, Missouri, High School — including automatic controls, ductwork, labor — everything.

This is unusually low, even for the Comfort Curtain, but costs of \$1.03 in Indiana; \$1.15 in Montana; and \$1.12 in South Dakota were *usual and typical* of the amazing savings offered by a Lennox Comfort Curtain System using Gas.

Money saving, safe Gas units are being installed in thousands of schools across the country. If you have specific questions, your local Gas company or a Lennox specialist — or both — will be available to assist the architects and engineers to illustrate how this equipment can best be applied to any specific school plan. Check the facts about Gas and you'll see — modern Gas heating out-performs all other fuels.

Call your local Gas company or write to Lennox Industries Inc., 1701 East Euclid Ave., Des Moines 5, Iowa. *American Gas Association.*

UP goes door efficiency —

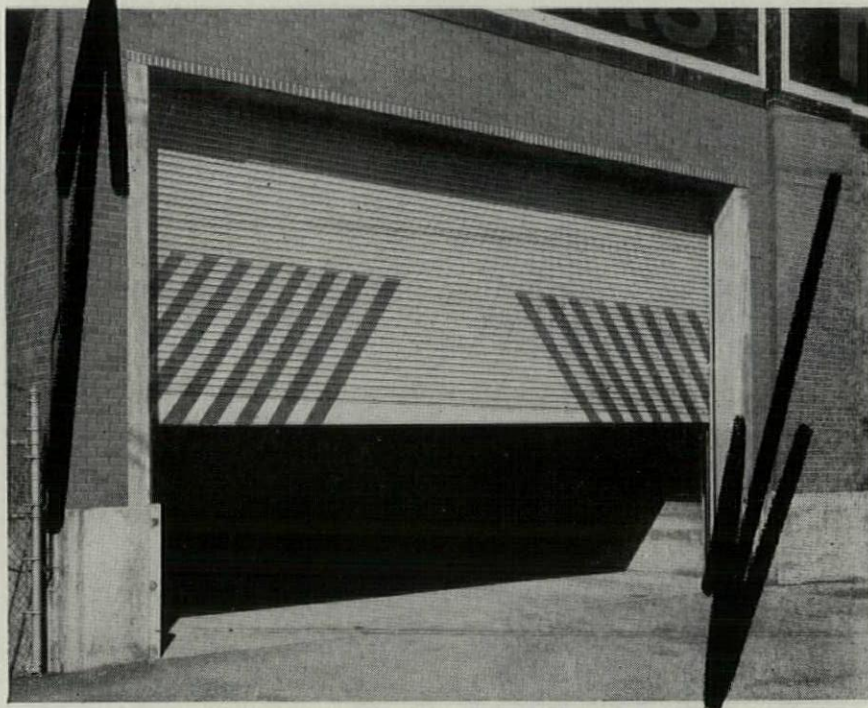

as door costs go DOWN, with
Kinnear Rolling Doors

The *coiling upward action* of Kinnear Rolling Doors saves time, manpower, and money!

The curtain of interlocking steel slats, *originated* by Kinnear, provides *vertical door action* at its very best!

All floor and wall space is fully usable at all times.

Even ceiling areas remain com-

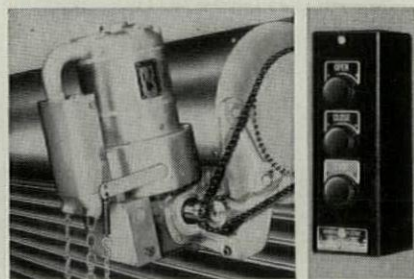

Kinnear Power Operators give time-saving, push-button control of Kinnear Rolling Doors — from a single point or any desired number of convenient locations.

pletely clear; leaving maximum room for use of hoists, lift trucks, and similar equipment.

When closed, the doors form all-metal barriers against wind, weather, intruders, and vandals.

Steel or Aluminum

Kinnear Rolling Doors are made of steel, aluminum, or other metals. Built to fit any opening in old or new buildings. Motor, manual, or mechanical control.

Steel Doors Heavily Galvanized

Heavy, hot-dip galvanizing gives Kinnear's steel doors lasting resistance to corrosion and the elements (1¼ oz. of pure zinc per sq. ft. of metal, ASTM standards). Kinnear Paint Bond makes them ready immediately for thorough coverage and adherence of paint.

Write for full details on Kinnear Rolling Doors.

The KINNEAR Mfg. Co.

FACTORIES:
1640-60 Fields Ave., Columbus 16, Ohio
1742 Yosemite Ave., San Francisco 24, Calif.
Offices and Agents in All Principal Cities

KINNEAR
ROLLING DOORS
Saving Ways in Doorways

SHOPPING CENTERS

continued from page 131

would have been out-of-pocket by at least 50 cents per square foot, and there would have been no return on his equity investment. If the department store were so outstandingly successful that its volume reached \$114 per square foot, the owner would just cover out-of-pocket costs."

While lenders are increasingly critical of such uneconomic leases, developers point out that if lenders did not insist on so many big-name tenants, they would not have to give the department stores a "free ride" and make their money on the smaller tenants, who pay higher rentals. The developer, in fact, is constantly squeezed between the two giant partners that he must have to make a large center work. The department store demands lease terms that sometimes do not allow the developer to break even on the space; the lender insists on top-credit names but turns down a loan if he believes the developer has given away too much in order to attract top names.

The squeeze

This squeeze has become critical in the past year or so, largely because of tight money. The lenders are no longer satisfied with high interest rates on low value loans. They are even asking for various devices which will allow them to share in the profits of the center. One of these devices is the participation clause, which has become popular in the past two years. This allows the lender to get a small chunk (generally about 2 per cent) of earnings over a certain minimum figure. It gives the lender a hedge against inflation the same way the percentage lease protects the developer, but he does it by siphoning off some of the developer's profits. To the same end, Northwestern Mutual has made several "larger-than-usual loans" for which it has received, besides the going interest rate, 20 to 40 per cent direct stock ownership in the centers (FORUM, March '60). Prudential has even taken stock options on deals still in the planning stage, but claims that this sort of deal will disappear when mortgage money is easier to obtain. Other lenders are chary about taking an equity position in a center, feeling that this is beyond their province as mortgage lenders.

Another major problem facing devel-

opers is the growing direct competition from large department stores and lenders who are building their own shopping centers. Of course, the department chains have been major factors in such development all along, and have been chiefly responsible for building about half of today's 70 regional centers and some of the smaller centers. But their prominence as developers is growing, boosted by their increasingly favorable position in making leases with other developers. (One large developer struggled for months to get some sort of economic lease with a huge department store for a new shopping center, and finally resignedly sold the land to the store, which developed the center itself.)

The lender's direct competition with the developer is of less importance than that of the retailers, but Prudential, Massachusetts Mutual, and Connecticut General have all built their own centers in recent years. However, the insurance companies have not been happy with many of the snarls encountered in leasing, building, and operating some of these centers, and it is likely that they will discontinue their program of direct investment, or at least curtail it drastically.

The developer, meanwhile, has his own troubles stemming entirely from the internal economics of shopping centers themselves. Because of rising taxes, sometimes disappointing rental income, and a multitude of lesser factors, shopping centers are not always working out to be as profitable as was once expected. Bruce Hayden says: "Some centers are profitable, but indications are that the degree of profitability is surprisingly low. . . . The early figures indicate a return on equity averaging less than 6 per cent." Edmund Thomas, of Brooks, Harvey & Co., New York mortgage brokers, estimates "reasonable returns" on a developer's investment at about 10 to 15 per cent. Other estimates peg returns at 8 to 9 per cent, but, at any rate, few developers of the larger centers have yet realized anything like the much larger returns that were once predicted. With the growing emphasis on merchandising, and the rising costs of land and building, the complexion of investment has changed radically. Experience has shown that it takes at least three years

continued on page 240

All Steel **X-PANDA**[®]

SHELVES by **hc**

the
MODERN
pre-fabricated
shelf for
MODERN
BUILDING

*Proven in actual use
in over
\$1,000,000,000
of construction!*

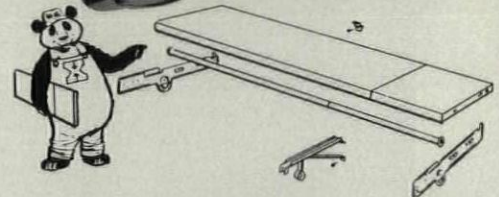
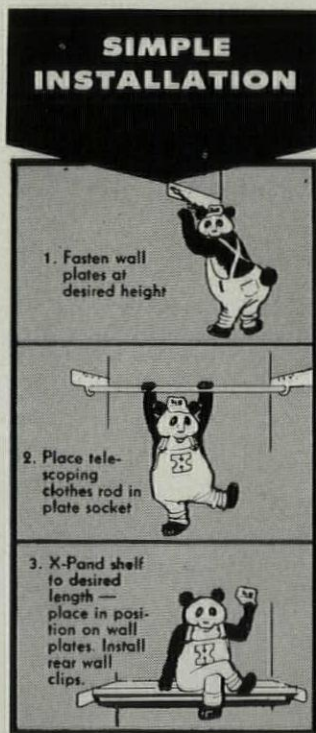

X-PANDA . . . THE COMPLETE ANSWER TO YOUR SHELVING PROBLEMS

- All steel shelves . . . maintenance free
- Strong . . . can be loaded to 30 lbs per linear foot
- Choice of two beautiful finishes - linen or greytone
- All sizes have 13" length adjustment. Can be compounded to any length.
- Completely fabricated and packaged.

TYPICAL INSTALLATIONS

Benning Terrace
Washington, D.C.
Architect:
Hogan Egan Wilson
& Corser

Wakefield Garden Apartments
Baltimore, Maryland
Architect:
Benjamin Brotman
Stephen Kornreich, Associate

Proctor Community Hospital
Peoria, Illinois
Architect:
Lankton-Ziegele-Terry & Associates

clip and mail
TODAY!

Quality Materials for Builders

hc
products co.

Princeville, Illinois

*Trade Mark of Home Comfort Mfg. Co.

hc products co. F-200
Princeville, Illinois

Please rush me literature on X-PANDA

Name _____
Street _____
City _____ State _____



BUILDING PRODUCTS



Memorial Student Union Building, Southern Connecticut State College. Architect: Carl R. Blanchard, Jr., A.I.A., New Haven, Connecticut.

STYROFOAM®

**delivers permanently low "K" factor,
lower costs for Connecticut college building**

Low thermal conductivity—"K" factor—was a major point in the choice of Styrofoam† to insulate the Memorial Student Union Building at Southern Connecticut State College. The building—which will house dormitories, apartments, cold storage areas, dining rooms, and activities rooms—required permanent insulation.

The application required an insulation with low moisture absorption, a low thermal conductivity factor, and one that would act as its own moisture barrier. Styrofoam was specified as the sole insulation material in the building—for all exterior cavity walls, for the foundation perimeter, and for all interior low temperature rooms.

Labor cost savings were also an important benefit from using Styrofoam. For example, one use of Styrofoam was in the exterior wall which was designed as a plenum chamber. Inside this 10" plenum cavity, the interior face of the exterior wall was insulated with Styrofoam applied by means of a water base adhesive.

The use of Styrofoam helped save construction costs by eliminating the need for battens, i.e., nailing of 2 x 2's over the insulation, as would be required with other insulation materials.

Because of its unique water and water-vapor barrier properties that bar moisture and won't absorb water, Styrofoam provides permanent, low-cost insulation efficiency for comfort and low temperature space. And its light weight makes installation fast and easy. For more information, write THE DOW CHEMICAL COMPANY, Midland, Michigan, Plastics Sales Dept. 1701LH4.

Other Dow building products

SCORBORD*—(Pat. applied for) Superior rigid insulation for foundation perimeters, slab floors. Exclusive pre-scored feature speeds installation.

ROOFMATE*—Lightweight rigid insulation for built-up roofs serves as its own moisture barrier. Reduces blistering, resultant leaks.

POLYFILM*—High quality polyethylene film for temporary enclosure or moisture barrier under slab or insulation.

SARALOY* 400—elastic sheet flashing conforms to surface contours. Bonds to any construction material. Won't crack. ^{*TRADEMARK}

†Dow's registered trademark for its expanded Polystyrene



Both walk-in refrigerators are insulated with Styrofoam.



Main dining room, showing exposed concrete roof structure.

THE DOW CHEMICAL COMPANY • MIDLAND, MICHIGAN

See the "DOW HOUR of GREAT MYSTERIES" on NBC-TV



Photo courtesy of Mel Warshaw, Inc., Miami (creators of Jay Originals and Trend-Setter fashions)

FASHION NOTE FOR 1960 — Advanced styling is an art, demanding the very epitome of creative genius. It's an incentive to feminine shoppers. And in like manner it influences industrial buyers . . . even in the selection of drinking-water equipment, such as these two trend-setting models by Halsey Taylor. In fact, if it's Taylor-made, it's the most modern in its field.

The Halsey W. Taylor Co., Warren, O.

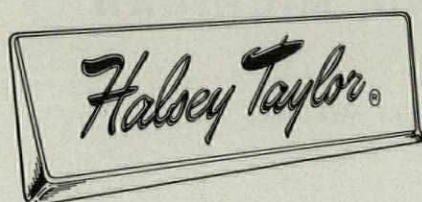

this is the new
WALL MOUNT *

It's a Halsey Taylor first! Mounts on the wall, off the floor. Compact, easy to keep clean, with no corners or crevices to catch the dirt.

* Patent Pending

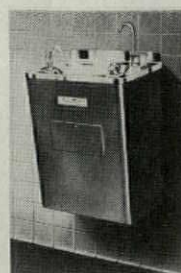

new wall-mounted
COFFEE BAR

Gives instantaneous hot water for serving up to sixty 8-oz. cups of hot coffee. Goose-neck type dispenser with a push-down lever. No exposed fittings.

ASK FOR LATEST CATALOG, OR SEE SWEET'S OR THE YELLOW PAGES

360

SHOPPING CENTERS

continued from page 237

before a large center begins to generate the income that allows an owner handsome profits, so that he can benefit from the leverage of his percentage leases. (If minimums cover fixed costs, a developer's net profits can rise very fast once sales begin to rise well above the minimum.)

Today, the developer must have a bigger chunk of equity money and may have to sell stock to raise it. Rouse recently sold a one-half interest in one of his centers to the public, and prior to that had sold \$3 million of stock in his own development company, Community Research & Development, with which to build new centers throughout the U.S. This gambit is being considered by other developers, for it will allow them more flexibility in the use of their own limited investment capital.

No room for amateurs

If the developer's role in future shopping centers will be somewhat more restricted than it has been, it will still be pivotal. He has become a professional, who relies on the advice of a small army of professional consultants specializing in economics, design, location, structure. **The amateurs** are disappearing fast; they either drop out of sight or else, by making their mistakes and seeing them through, they earn the status of professionals. The lenders are discouraging any influx of new amateurs. Bruce Hayden says positively: "We no longer even consider financing amateurs. It is too big a game with too high stakes for the amateurs to have any future position in it." By weeding out the shakier operators who have built many of the least successful centers, this policy is also giving the business a new measure of stability.

The future need for shopping centers, whether built by stores, lenders, or professional developers, seems assured, as long as population grows and the suburban stretch retains its elasticity. Most observers feel that Homer Hoyt's predictions of some 600 million square feet of new shopping-center building space in the next 15 years is conservative. Hoyt himself warns against overexpansion, and building in the wrong places, however: "After all, we won't know that we've built too many shopping centers until a lot of people have been hurt." **END**

THE NEW RIVALS

continued from page 139

sign of service stations throughout the world. The shaping of their corporate offices was another matter. The job was therefore given to a relatively more "architectural" architect, J. Gordon Carr.

Some clients have apparently begun to appreciate that the approach of the architect to corporate problems is not quite so specialized and that, indeed, it does involve a degree of over-all responsibility that is more valuable than hypersensitivity to current trends.

Thus, in the design of the C.I.T. Building on Madison Avenue, Harrison & Abramovitz, having been told they would not be chosen to do the interiors, were consulted as to what the general nature of the work should be. As the real estate officer of another corporation, Corn Product's Jack Frost, puts it: "You just don't feel that decorator-oriented designers have the professional standards necessary for such an important job." It is undoubtedly in an effort to combat this disadvantage that some interior designers have not only hired big-name architects to work on their staffs, but have even suggested being credited as "interior architects."

In other cases, however, architects have not made it easy for clients to understand their availability for all problems of modern building. There is, for example, the matter of "total design."

The economics of urban architecture dictate that most large buildings, even when nominally owned by a major corporation, have to be leased out to many smaller tenants, each of whom has his own ideas and his own budget. The building's architect, working either for a speculator or a corporate owner, generally prefers not to get involved with the multiple haggling and many conflicts of interest that would result from working with them all. In a fairly condescending manner, he calls in the "space cadets" to take care of the tenants' needs, human and otherwise. He thereby, of course, loses control of whatever integral design virtues the building might have had, and the tenants' vice presidents start mulling where to put their fireplaces.

Perhaps an important factor in the architect's decision not to go beyond the basic building is that he faces enough complexities already, building in cities, without expanding his shop with the

continued on page 244

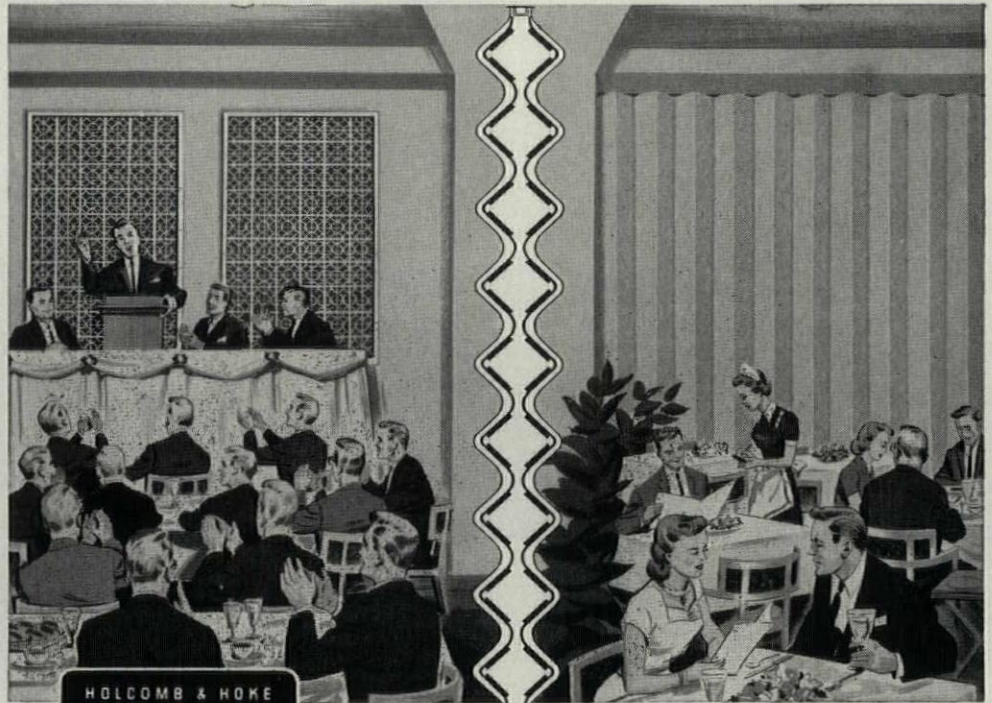

HOLCOMB & HOKE
FOLDOOR

Soundguard

...new way to combine sound separation
with folding door flexibility and beauty

You can now specify *both* sound and space separation—and also get the flexibility and beauty of fabric-covered folding doors and partitions—with SOUNDGUARD. Soundguard's greater sound reduction is due not only to the denser sound insulation within the partition itself, but also to the tight *perimeter sealing* that blocks sound from passing around jambs and operating edges. An outstanding Soundguard feature!

Soundguard is smart in appearance, too. The rugged frame is covered with your choice of beautiful vinyl fabrics which withstand abuse—assure long, active life and easy maintenance.

The FOLDOOR line is complete—a door or partition for every commercial or residential application.



Sold, installed and serviced by factory-trained FOLDOOR and FILIGRILLE distributors

... new, different, functional, decorative. A $\frac{3}{4}$ " thick styrene grillework in standard designs, factory fabricated in customized panels. Ideal as space dividers and screens for interior or exterior use. Variety of complete framing systems adaptable to all commercial and residential applications.



FOLDOOR 16e/HO
DUAL SOUND 22d/HO
FILIGRILLE 22h/HO

Holcomb & Hoke Mfg. Co., Inc. Dept. A 23
1545 Van Buren Street, Indianapolis 7, Indiana

Please send complete information on:

FOLDOOR Soundguard FiliGrille grillework

NAME _____

ADDRESS _____

CITY _____ STATE _____



cuts out
the
biggest step
in
installation

Loma Loom, the carpet that grows out of sponge rubber

No underlay needed. No special tools required. Loma Loom is ready to install, on any surface. Ready to install with minimum waste, with the least possible expenditure of time and money. It's all in the structure itself. Loma Loom is carpet with its own inseparable sponge rubber base. Not old-fashioned rubber-backed carpet. Not merely carpet attached to rubber. Loma Loom is an all-in-one, complete unit—so it's practically half-installed when you buy it!



Easy installation's only one of the advantages. Loma Loom permits unlimited design possibilities and perfect-fit restoration. Sections can be cut out, other sections will fit in—perfectly, accurately, smoothly. Loma Loom comes in a full range of decorator colors or custom-dyed to your specifications, in qualities from ultra-luxury to ultra-economy. Changes every carpet specification into the most practical, economical, versatile surface that ever covered a floor!

Distributed by: Berven Carpets Corporation, Los Angeles and San Francisco, Calif.; Vol T. Blacknall Co., Atlanta, Ga.; Florwall Inc., Pittsburgh, Pa.; James Carpet and Furniture Distributors, Inc., Syracuse, New York; Theodore Johnson Carpet Co., Minneapolis, Minn.; Kelly Inc., Seattle, Wash.; The New England Floor Covering Co., Hartford, Conn. and Boston Mass.; A. D. Radinsky & Sons, Denver, Colo.; Elias Wilf Corp., Balt., Md., Phila., Pa.

Loma Loom, trademark of Sidney Blumenthal & Co. Inc. One Park Avenue, New York 16, N. Y. A Division of Burlington Industries



AllianceWall

PORCELAIN ON STEEL AND ALUMINUM

NOW—Complete freedom of design with slim-line AllianceWall

Advanced AllianceWall production techniques offer architects and builders the combined advantages of design flexibility and on-the-job workability. Special continuous coil process uses slim, 28 gauge metal offering many advantages to the users. It's easier to saw into any number of different shapes and is unaffected by climate, sunlight, corrosives, and is more resistant to impacts. AllianceWall is lighter in weight and less expensive, too. Available now in 26 uniform lustrous colors and stipple patterns . . . plus black and white; both veneer panels and insulated sandwich panels. For full details, write for AllianceWall literature, today!

**VENEER
PANELS
FOR
EXTERIOR
USE**

First Federal Savings and
Loan Association Building
Uniontown, Pennsylvania
Architect: John Schurko*
General Contractor:
Fairchance Lumber*
Curtain Wall Contractor:
Golomb Paint &
Glass Co.*
*Pittsburgh

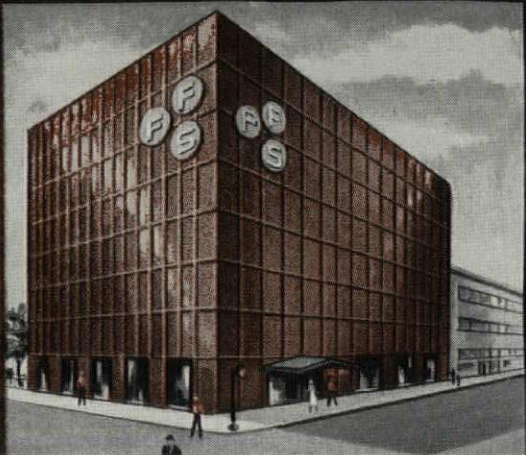
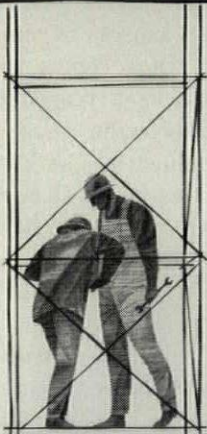

**ALLIANCEWALL DIVISION,
ALLIANCEWALL, INC.*
ALLIANCE, OHIO**

*an **amp** subsidiary

SALES FOLLOW THE RAILS



The railroads paved the way for industrial progress in the West and that is as true today as it was in the 1800's.

Distribution opens the channels for sales. And efficient, economical transportation is a big factor in distribution.

That's where Union Pacific enters the picture. When you have a plant located on or near U. P. trackage you are in a position to benefit from a freight transportation service that is unsurpassed.

That has been our contribution to industrial progress; to build and constantly improve our service to shippers.

So we suggest that if you have need for a plant in a western location, you give serious consideration to a tract in the "Union Pacific West."

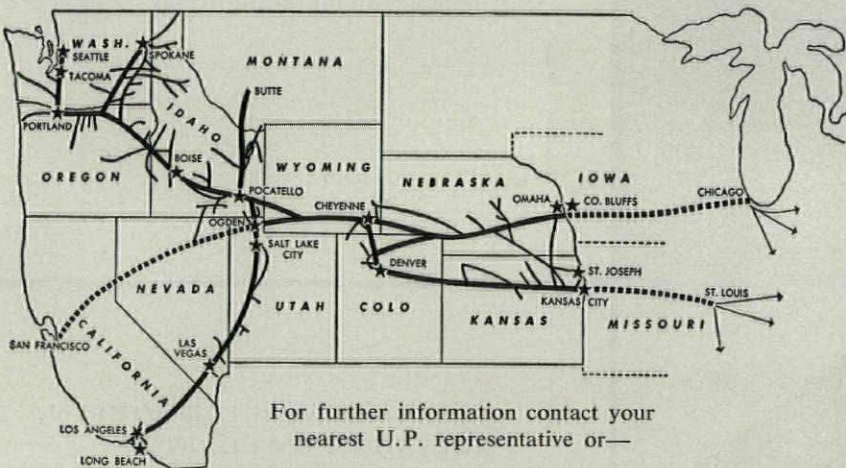

For further information contact your nearest U.P. representative or—

Industrial Development Dept.
UNION PACIFIC
Railroad
OMAHA 2, NEBRASKA

THE NEW RIVALS

continued from page 241

many talents necessary to plan, detail, order, and worry through all the interiors equipment necessary for the modern office. The client is therefore easily convinced that the architect has not kept abreast of the industrial processes that determine to an increasing degree the shape and look of working environments. As Max Abramovitz has expressed the problem: "If we were to hire enough people to design the interiors of—say—the new Time & Life Building, it would alter the balance of our office. It would change the nature of the whole operation. But perhaps its nature *should* be changed."

Unconscious emulation

There are, however, some areas in which architects and designers are coming closer than even they realize.

Abramovitz, for example, acknowledges that if his firm did fewer jobs, a slightly altered office staff on which industrial designers would be represented might better handle the total design of each building. This, to be sure, would scale the office down to much more modest proportions. The possibility of a smaller, better-rounded office seems to have a special attraction for the current generation of architects. To name two, George Nelson (51) and Eliot Noyes (49) both have firms that are balanced to handle all aspects of almost any design problem that comes their way. Noyes, who has been responsible for an extraordinarily wide range of carefully selected products and buildings (from X-ray machines to a \$3.5 million education center for I.B.M.), comes closer to the European concept of the total designer than any other architect or designer in the U. S.

There is another answer, of course, which is to make a firm *large* enough to take care of all design opportunities. This is the route that Skidmore, Owings & Merrill and Welton Becket & Associates, among others, are following. Nearly 80 per cent of the work now handled by Welton Becket involves total design, the firm has built up an interiors department of over 40 people (large, but far below Loewy's staff of 60 designers assigned to architectural projects). Becket's Kaiser Center in Oakland, Calif., which is to be completed in June, will perhaps be the largest totally designed office building in the U.S. Becket has, however, been accused of obtaining his wide range

at the cost of design quality in depth.

Two examples of the total design work done by S.O.M., a firm which has the reputation of not diluting its standards, are Cincinnati's Terrace Plaza Hotel, where both exterior and interior design, as well as most of the furnishings were executed by the architects (though the unity has since been destroyed by the new Hilton management), and the Warren Petroleum Building in Tulsa where the S.O.M. design included such "nonarchitectural" items as desks and carpets. S.O.M. has confessed that one of the reasons for the rapid growth of its design department (now up to 40 people) was that in farming out the design of the interior spaces and equipment, too many architects have jeopardized control of the entire building.

Some critics see, in the similarity of the business methods that both architects and designers now use, another indication that the two disciplines are really merging without knowing it. They both charge for design work according to any one of several methods. The most usual of them are these: 1) *cost* (including salaries plus overhead plus profit) times a factor, often in the neighborhood of 180 per cent; 2) *an hourly rate*, which may vary from \$10 to \$25 depending on many considerations, including how ardently the job is desired; 3) *a flat fee*, somewhat more scientifically arrived at than the \$50,000 which Loewy made with George Washington Hill that a better-selling Lucky Strike package could be designed; 4) *an A.I.A.-type contract arrangement*.

Other critics continue to hope, rather wistfully, that there may be a more radical solution to the architect-designer competition: that the designers will just go away. These critics base their hope not on spring breezes or on any discernible trend, but rather on the theory that the sales surveys and business currents that designers have been riding will take them to a dusty end. "When a depression comes," one of these hopeful architects prophesied recently, "they'll all be blown away like so much fluff in the wind. They're just in architecture as long as there's money there—we're in it for life."

A more probable forecast is that designers will remain as a challenge to architects, and that between the two, because of continued confrontation, there may grow some resemblances. END

CUSTOM EFFECTS in ORNAMENTAL GRILLES at low cost!

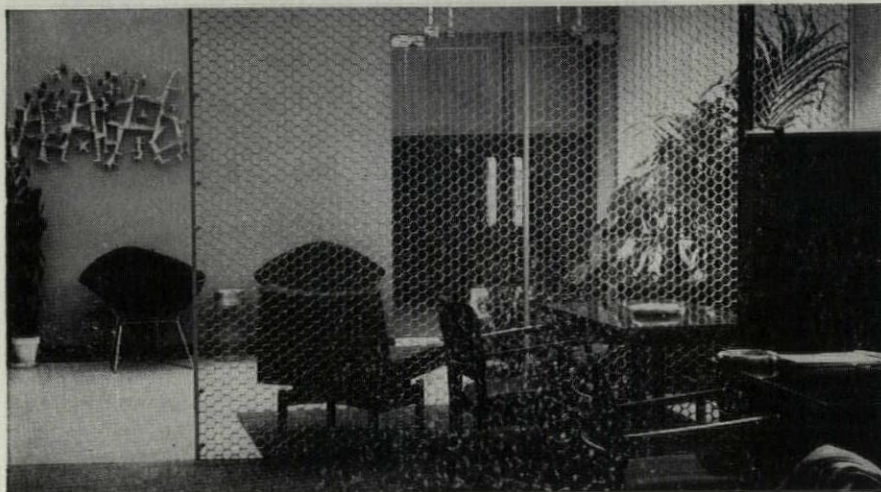

IRVICO'S mass production of "ALUMINUM GRIDSTEEL" now enables the designer to achieve the "custom look" in grillework economically.

"ALUMINUM GRIDSTEEL" is a honeycomb mesh that allows great flexibility in scale and texture, and diversity of application. Its third-dimension affords varying degrees of opacity depending on angle of view.

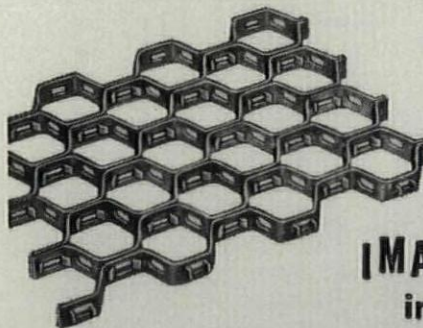

"ALUMINUM GRIDSTEEL" is available in rigid or flexible panels of various sizes... anodized, painted or mill finish.

Write for
colored brochure
IMAGINEERING
in ALUMINUM
"GRIDSTEEL"®



IRVICO

IRVING SUBWAY GRATING CO., Inc.

ORIGINATORS OF THE GRATING INDUSTRY

Offices and Plants at
5061 27th St., LONG ISLAND CITY 1, N. Y.
1861 10th St., OAKLAND 10, CALIFORNIA



FOR THE
WORLD'S LARGEST
OFFICE BUILDING...

51 acres

Grand Central City will rise 59 stories in the heart of New York. It will house a permanent working population of 25,000—with daily visitors expected to exceed a quarter million!

OWNER: Grand Central Building, Inc.
Erwin S. Wolfson, president

ARCHITECT: Emery Roth & Sons

DESIGN CONSULTANTS:
Walter Gropius and Pietro Belluschi

GENERAL CONTRACTOR: Diesel Construction Co., Inc.

STRUCTURAL ENGINEER:
James Ruderman

of electrified floor system

... FURNISHED BY *Fenestra*

FIFTY-NINE STORIES HIGH ...

with room for a work force of 25,000—Grand Central City will be the largest commercial office building ever built. A monumental job for architect, engineer, contractor and owner.

Fenestra will supply 2,200,000 square feet of Holorib Elect-Re-Form to reinforce and provide electrification to the floors of this building. As a reinforcing form, it offers top load capacity, permits use of thinner, stronger concrete slabs. As an electrification system, it offers maximum flexibility . . . lets you provide electrification more economically wherever needed *without* wasteful "dead" cells.

New Fenestra Holorib roof and floor structural systems may answer a design problem now facing *you*. For full information, see Sweet's File, call your Fenestra representative (he's in the Yellow Pages), or write: *Fenestra Incorporated, Dept. AF-4, 2296 E. Grand Blvd., Detroit 11, Michigan.*

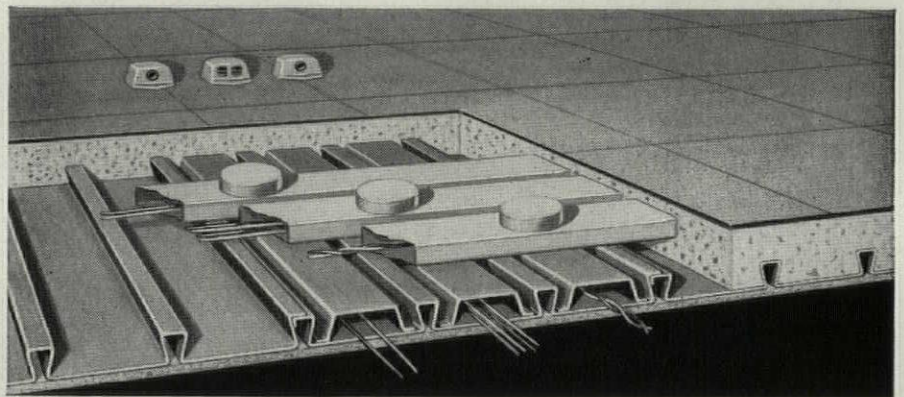

Versatile Holorib Elect-Re-Form can be supplied with one, two or three cells as the job requires—provides electrification where needed without wasteful "dead" cells. Pyramidically designed ribs key into concrete—a more positive bond, higher strength.

Fenestra

INCORPORATED

BUILDING PANELS • DOORS • WINDOWS • CURTAIN WALLS

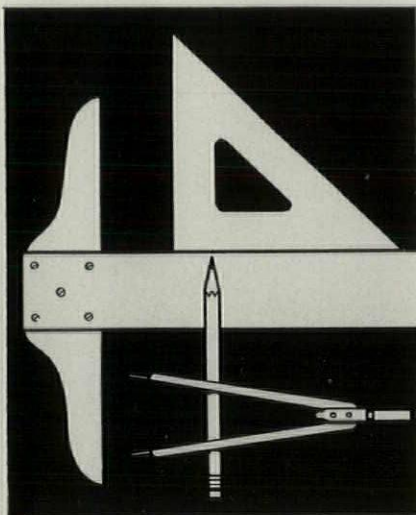

Tips on savings in restaurant design . . .

Save money for your clients by creating modern restaurant plans that use paper—the personal food service.

All-paper food service makes *the big difference* in the cost of constructing and operating all types of food service operations. It reduces the capital investment required for cubage as well as kitchen equipment. Dishwashing and breakage are eliminated and service is faster where paper is used. But you will want to learn more, so—

WRITE FOR THIS BOOK



Get this 60-page manual of helpful information on all phases of food service, with cost studies and case histories of money-saving ideas from hundreds of restaurants and institutions. Write on your letterhead for a copy.

Paper Cup and Container Institute, Inc.
250 Park Avenue, New York 17, N. Y.

PAPER
the *personal*
food service

A cmé Industries, Inc.	90, 91	<i>Gray & Kilgore, Inc.</i>
Aetna Steel Products Corp.	41	<i>Jamian Advertising & Publicity, Inc.</i>
Air Devices, Inc.	194	<i>The Powerad Company</i>
Alexander Drafting Equipment Co.	58	<i>Clyde D. Graham Advertising</i>
Allegheny Ludlum Steel Corp.	166	<i>Erwin Wasey, Ruthrauff & Ryan, Inc.</i>
Allianceware, Incorporated	243	<i>Waldie & Briggs, Inc.</i>
Aluminum Window Manufacturer's Assn.	66	<i>Wildrick & Miller, Inc.</i>
American Brass Co.	250	<i>Kenyon & Eckhardt, Inc.</i>
American Bridge Division United States Steel Corp.	192, 193	<i>Batten, Barton, Durstine & Osborn, Inc.</i>
American Gas Association	76, 77, 222, 223	<i>Ketchum, MacLeod & Grove, Inc.</i>
American-Marietta Company	24	<i>Turner Advertising Agency</i>
American-Olean Tile Co.	158	<i>Arndt, Preston, Chapin, Lamb & Keen, Inc.</i>
American-St. Gobain Corp.	26, 27	<i>G. M. Basford Co.</i>
Amplex Mfg. Co.	34	<i>Lee Keeler, Inc.</i>
Balfour & Co., Walter	177	<i>Marshall & Coch, Inc.</i>
Bayley Co., William	230	<i>Wheeler-Kight & Gainey, Inc.</i>
Bell & Gossett Company	167	<i>Perrin-Paus Company</i>
Bituminous Coal Institute	191	<i>Van Sant, Dugdale & Co., Inc.</i>
Black White Limestone Co.	58	<i>Halbach Advertising</i>
Blumenthal & Co., Inc., Sidney	242	<i>Altman-Stoller Advertising, Inc.</i>
Bradley Washfountain Co.	233	<i>Kirkgasser-Drew Advertising</i>
Briggs Manufacturing Co.	8	<i>MacManus, John & Adams, Inc.</i>
Brunswick-Balke-Collender Co., Inc.	59, 60, 61, 62	<i>Garfield-Linn and Company</i>
Bulldog Electric Products Division I-T-E Circuit Breaker Co.	160, 161	<i>MacManus, John & Adams, Inc.</i>
Carter-Waters Corporation	232	<i>Potts-Woodbury, Inc.</i>
Chase Brass & Copper Company	52, 53	<i>Cunningham & Walsh, Inc.</i>
Chicago Hardware Foundry Co.	184	<i>Wilson Advertising Service</i>
Cirvac Plastics	179	<i>Davies and McKinney Industrial Adv. Agency</i>
Committee On Steel Pipe Research	216, 217	<i>Smith, Taylor & Jenkins, Inc.</i>
Consoweld Corporation	209, 210	<i>Erwin Wasey, Ruthrauff & Ryan, Inc.</i>
Darlington Brick Co., Div. of Central Commercial Co.	198, 199	<i>The Fensholt Advertising Agency, Inc.</i>
Douglas Fir Plywood Assn.	86, 87	<i>The Condon Co.</i>
Dow Chemical Company	238, 239	<i>MacManus, John & Adams, Inc.</i>
Dunham-Bush, Inc.	197	<i>William Schaller Co., Inc.</i>
Dusing and Hunt, Inc.	74	<i>BVM Advertising Service</i>
Electric Lighting, Inc.	185	<i>Golden-George Advertising</i>
Electric Time Company, Inc.	14	<i>Randolph Associates</i>
Eljer Division of The Murray Corp. of America	32	<i>Fuller & Smith & Ross, Inc.</i>
Fenestra Incorporated	246, 247	<i>Brooke, Smith, French & Dorrance, Inc.</i>
Fiat Metal Mfg. Co.	35	<i>Waldie and Briggs, Inc.</i>
Firestone Rubber & Latex Products Co.	55	<i>Campbell-Ewald Company</i>
Flintkote Company, The	226	<i>Marschalk & Pratt Div. of McCann-Erickson, Inc.</i>
Flynn Mfg. Co., Michael	234, 235	<i>Erwin Wasey, Ruthrauff & Ryan, Inc.</i>
Follansbee Steel Corp.	162	<i>The Albert P. Hill Co., Inc.</i>
General Air Conditioning Corp.	44	<i>Hal Stebbins, Inc.</i>
General Bronze Corp.	70	<i>Wildrick & Miller, Inc.</i>
General Electric Company	42	<i>Young & Rubicam, Inc.</i>
Globe-Wernicke Co.	12	<i>Strauchen & McKim Advertising</i>
Gregory Industries, Inc.	211	<i>(Nelson Stud Welding Div.) The Griswold-Eshleman Co.</i>
Houghton Elevator Co.	46	<i>Besson-Feichert, Inc.</i>
Hauserman Co., The E. F.	22, 23	<i>Meldrum & Feosmith, Inc.</i>
Haven Busch Company	10, 11	<i>Schmidt & Sefton</i>
Haws Drinking Faucet Co.	180	<i>Pacific Advertising Staff</i>
H-C Products Co.	237	<i>Marvin Hult Associates</i>
Heywood-Wakefield Co.	174	<i>Charles W. Hoyt Co., Inc.</i>
Holcomb & Hoke Mfg. Co.	241	<i>Boswell & Jacobs, Inc.</i>
Hubbell, Inc., Harvey	188	<i>Peck-Adams Inc.</i>
Hunter Douglas Div. of Bridgeport Brass Co.	50	<i>Doyle Dane Bernbach, Inc.</i>
Inland Manufacturing Division General Motors Corp.	47	<i>Geyer, Morey, Madden & Ballard, Inc.</i>
Inland Steel Company	224, 225	<i>Edward H. Weiss & Co.</i>
Inland Steel Products Co.	170, 171	<i>Hoffman, York, Paulson & Gerlach, Inc.</i>
Insulrock Co. (Div. of The Flintkote Co.)	178	<i>Fred Gardner Company, Inc.</i>
Irving Subway Grating Co., Inc.	245	<i>Richmond Advertising Service, Inc.</i>
Johns-Manville Corporation	30, 31	<i>Cunningham & Walsh, Inc.</i>
Josam Mfg. Co.	151	<i>Allied Advertising Agency, Inc.</i>
Kalwall Corporation	181	<i>Noyes & Company, Incorporated</i>
Kawneer Co., The	182, 183	<i>Fuller & Smith & Ross, Inc.</i>
Kentile, Inc.	Cover IV	<i>Benton & Bowles, Inc.</i>
Kinnear Mfg. Co.	236	<i>Wheeler-Kight & Gainey, Inc.</i>
Knoll Associates, Inc.	29	<i>The Zlowe Company</i>
Koppers Company, Inc. Plastics Div.	33	<i>Batten, Barton, Durstine & Osborn, Inc.</i>

Lamson Corporation	228
<i>Chapman-Nowak & Associates, Inc.</i>	
Lees & Sons Co., James	176
<i>N. W. Ayer & Son, Inc.</i>	
Lennox Industries Inc.	84, 85
<i>Peitscher-Janda Associates, Inc.</i>	
Libbey-Owens-Ford Glass Co.	212, 213
<i>Fuller & Smith & Ross, Inc.</i>	
Louisville Cement Co.	37
<i>Doe-Anderson Advertising Agency, Inc.</i>	
Mahon Company, The R. C.	56, 57
<i>Dudgeon, Taylor & Bruske, Inc.</i>	
Marble Institute of America, Inc.	153
<i>Moore & Company, Inc.</i>	
McKinney Mfg. Co.	75
<i>Ketchum, MacLeod & Grove, Inc.</i>	
McLouth Steel Corporation	49
<i>Denman & Baker, Inc.</i>	
Mearl Chemical Corp.	184
<i>Richard-Lewis Advertising Corp.</i>	
Merchandise Presentation Inc.	184
<i>Arpadi-Sarett Associates</i>	
Miller Company, The	231
<i>Harrison House</i>	
Minneapolis-Honeywell Regulator Co.	73, 195
<i>Foote, Cone & Belding</i>	
Mobay Chemical Company	94
<i>Smith, Taylor & Jenkins, Inc.</i>	
Mueller Brass Co., The	175
<i>Price, Tanner & Wilcox Inc.</i>	
Murray Tile Company Division of American Olean Tile Co. ...	200
<i>Kentuckiana Advertising, Inc.</i>	
National Concrete Masonry Association..	28
<i>Roche, Rickerd & Cleary, Inc.</i>	
National Gypsum Company	152
<i>Batten, Barton, Durstine & Osborn, Inc.</i>	
National Lumber Manufacturers Assn.	92, 93
<i>Van Sant, Dugdale & Co., Inc.</i>	
New Castle Products Co.	229
<i>Caldwell, Larkin & Sidener-Van Riper, Inc.</i>	
Norton Door Closer Co.	25
<i>Erwin Wasey, Ruthrauff & Ryan, Inc.</i>	
Olin Mathieson Chemical Corp.	Cover III
<i>D'Arcy Advertising Company</i>	
Omark Industries, Inc.	45
<i>William Winter Advertising</i>	
Overhead Door Corporation	168, 169
<i>Fulton, Morrissey Co.</i>	
Overly Manufacturing Co.	2, 3
<i>Marsteller, Rickard, Gebhardt and Reed, Inc.</i>	
Paper Cup & Container Institute, Inc., The	243
<i>Fuller & Smith & Ross, Inc.</i>	
Peterson Window Corp.	58
<i>The Jaqua Company</i>	
Pistol, Inc., A. W.	44
<i>Dick Williams</i>	
Pittsburgh Plate Glass Co. 201, 202, 203, 204, 205, 206, 207, 208	
<i>Batten, Barton, Durstine & Osborn, Inc.</i>	
Plextone Corp. of America	43
<i>Lewis Advertising Agency</i>	
Portland Cement Association	20, 21
<i>J. Walter Thompson Co.</i>	
Republic Steel Corp.	88, 89
<i>Meldrum & Fewsmith, Inc.</i>	
Robbins Flooring Co.	40
<i>Schmidt & Sefton Advertising</i>	
Roddis Plywood Corp.	163
<i>J. Walter Thompson Co.</i>	
Rohm & Haas Co.	54
<i>Arndt, Preston, Chapin, Lamb & Keen, Inc.</i>	
Ruberoid Company, The	78
<i>Fuller & Smith & Ross, Inc.</i>	

Russell & Erwin Div. The American Hardware Corp.	227
<i>Noyes & Company, Inc.</i>	
Rust-Oleum Corp.	159
<i>O'Grady-Andersen-Gray, Inc.</i>	
St. Regis Paper Company	187
<i>Cunningham & Walsh Inc.</i>	
Schlage Lock Company	172, 173
<i>J. Walter Thompson Co.</i>	
Shlagro Steel Products Corp.	14
<i>Parsons, Friedmann & Central, Inc.</i>	
Simpson Logging Co.	48
<i>Lennen & Newell, Inc.</i>	
Sloan Valve Company	4
<i>Reincke, Meyer & Finn, Inc.</i>	
Smithcraft Lighting	96
<i>Parsons, Friedmann & Central, Inc.</i>	
Sonneborn Sons, Inc., L.	38, 39
<i>Adams & Keyes, Inc.</i>	
Soss Manufacturing Co.	82
<i>Stockwell & Marcuse</i>	
Spencer Turbine Co.	36
<i>William Schaller Co., Inc.</i>	
Steelcase, Inc.	154
<i>Aves, Shaw & Ring, Inc.</i>	
Stran-Steel Corporation	16, 17
<i>Campbell-Ewald Co.</i>	
Stromberg-Carlson Co.	186
<i>The Rumrill Company Inc.</i>	
Structural Clay Products Institute.....	64
<i>Henry J. Kaufman & Associates</i>	
Taylor Co., The Halsey W.	240
<i>The Advertising Agency of William Cohen</i>	
Temprite Products Corp.	16
<i>Watkins-Rogers, Inc.</i>	
Thiokol Chemical Corp.	18, 19
<i>Brown & Butcher, Inc.</i>	
Tile Council of America	68
<i>Fuller & Smith & Ross, Inc.</i>	
Trane Company, The	164, 165
<i>Campbell-Mithun, Inc.</i>	
Tyler Co., The W. S.	Cover II
<i>The Griswold-Eshleman Co.</i>	
Tyler Refrigeration Corp.	34
<i>Jones & Taylor, Inc.</i>	
Union Bag-Camp Paper Corp.	249
<i>Smith, Hagel & Knudsen, Inc.</i>	
Union Pacific R. R.	244
<i>The Caples Company</i>	
Unistrut Products Co.	63
<i>Roche, Rickerd & Cleary, Inc.</i>	
United States Plywood Corp.	219, 220
<i>Kenyon & Eckhardt, Inc.</i>	
U. S. Rubber Co. (Naugatuck Chemical Div.)	79
<i>Fletcher Richards, Calkins & Holden, Inc.</i>	
United States Steel Corp. (American Bridge Div.)	192, 193
<i>Batten, Barton, Durstine & Osborn, Inc.</i>	
United States Steel Corp.	80, 81
<i>Batten, Barton, Durstine & Osborn, Inc.</i>	
Universal Atlas Cement Co. (United States Steel Corp.)	51
<i>Batten, Barton, Durstine & Osborn, Inc.</i>	
Uvalde Rock Asphalt Co.	196
<i>Glenn Advertising, Inc.</i>	
Vonnegut Hardware Co.	15
<i>Caldwell, Larkin & Sidener-Van Riper, Inc.</i>	
Wal-Lok, Division of Lenawee Peerless	44
<i>La Vanway Advertising</i>	
Wasco Products, Inc.	83
<i>The Bresnick Co., Inc.</i>	
Washington Steel Corp.	72
<i>Cabbot & Coffman, Inc.</i>	
Westinghouse Electric Corp.	214, 215
<i>Fuller & Smith & Ross, Inc.</i>	

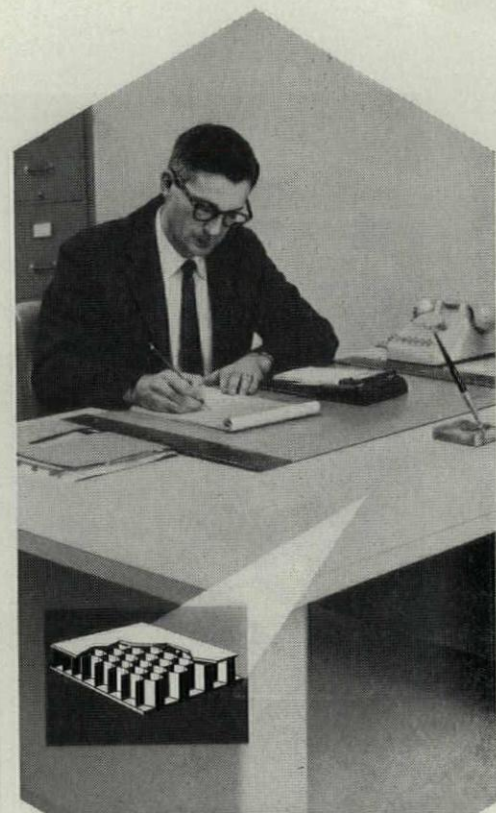

UNION HONEYCOMB in FURNITURE

Lightweight kraft HONEYCOMB core material speeds up, simplifies, improves construction of desks, tables, cabinets and other office fixtures. It's remarkably economical and can be bonded to almost any facing material. Durable HONEYCOMB "sandwiches" withstand years of punishment . . . require minimum finishing.

Free booklet describes many other Union HONEYCOMB advantages and structural uses—in walls, ceilings, partitions, room dividers and doors. Write for a copy.



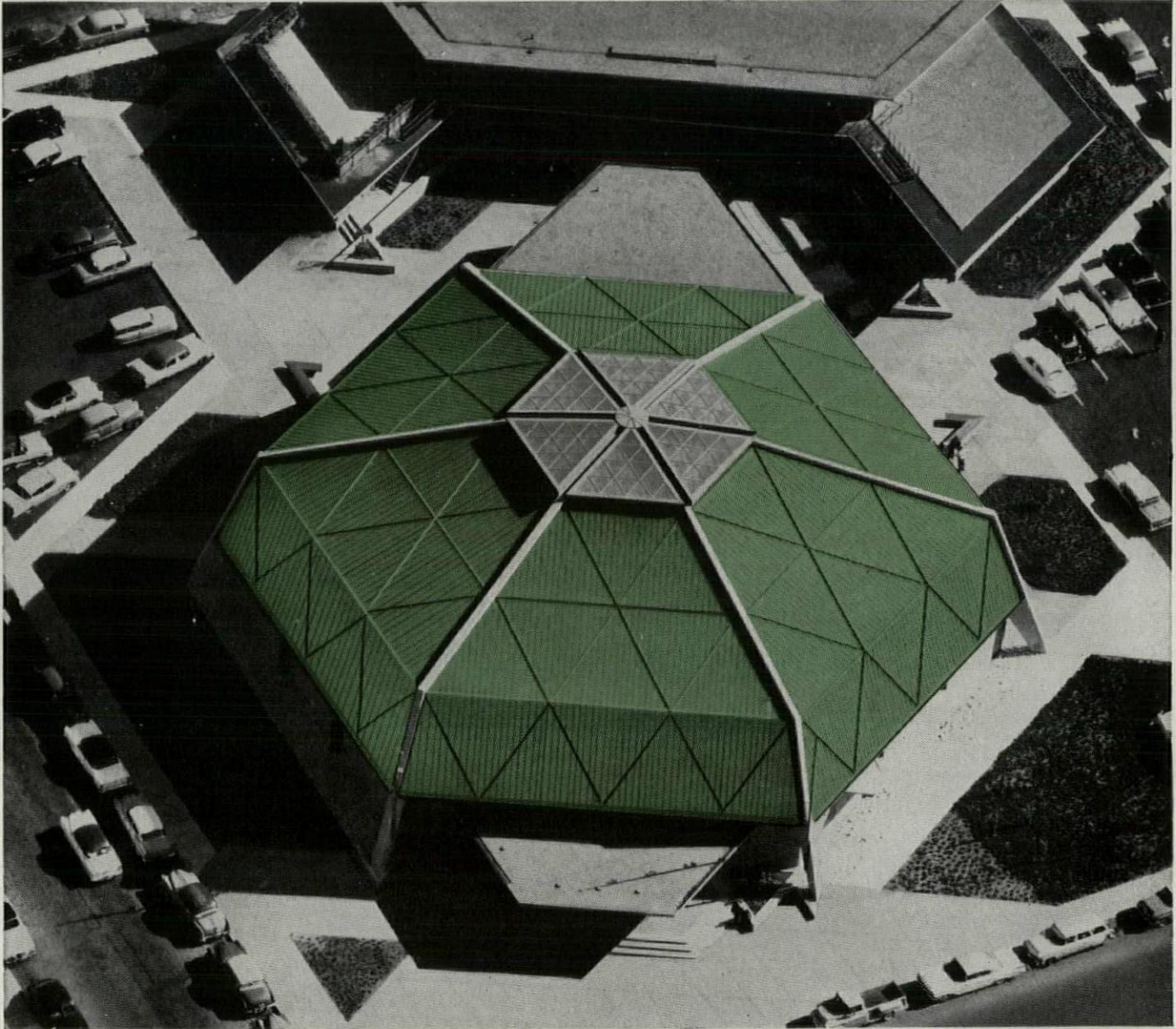

Copper gives lasting beauty to outstanding design

Whether viewed from ground level or from nearby Golden Gate Bridge, the copper roof of the Longshoremen's Memorial Building in San Francisco contributes much to the modern architecture of the structure.

Although each segment of the hexagonal mansard roof appears to consist of fifteen separate triangular roof areas, actually the standing seam copper roof is continuous on each slope between the concrete bents. The diagonal copper battens which create the pattern are above the standing seams.

Economy Copper Roofing, an Anaconda product, was selected because it provides a lasting and beautiful roof covering at savings in material and installation costs. Weighing 10 ounces per sq. ft., the standard sheets 16" x 72" are easy to handle and eliminate waste in forming roof pans of desirable dimensions.

Write for our "Modern Sheet Copper Practices"—109 pages of drawings, specifications and general information on copper sheet metal work. The American Brass Company, Waterbury 20, Conn.

6019



Memorial Building of the International Longshoremen's and Warehousemen's Union, San Francisco. ARCHITECT: Henry Hill, San Francisco. The dome is sheathed with about 18,000 sq. ft. of Economy Copper Roofing installed by Fire Protection Products Co., San Francisco.

Economy Copper Roofing
 an **ANACONDA**[®] product
 made by The American Brass Company

Owning . . . codes . . . fees . . . prisons

OWNING VS. RENTING

Forum:

You show that there is no easy answer to the question of owning vs. renting (FORUM, March '60) and that the decision is dependent upon each company's individual situation and space needs. We agree wholeheartedly. But we do not believe that this is a "do-it-yourself" decision. The economics of owning vs. renting may prove on paper the overwhelming advantage of owning your own office building, but if the wrong building is built at the wrong place at the wrong time, it will be a poor investment.

LEONE J. PETERS, *president*
Cushman & Wakefield, Inc.
New York City

Forum:

There are some further implications in the corporate ownership of office buildings:

At the outset the building is new and shining. So were the fine new buildings of the nineties and of the twenties. Many of these are gone and the survivors have had to expend large sums to modernize. Moral: Depreciation and obsolescence are something real, not just savings on income tax.

Individual owners of a building rented out to others are rapidly becoming aware of the need for concerted action on taxes, neighborhood improvements, and urban renewal. It is a regrettable fact that corporate ownerships, by and large, are less alert and sometimes not even passively cooperative. This is particularly true where the building owned is not the home office but only a branch. The resident vice president is reluctant to "stick his neck out" on local issues or to ask the home office for a contribution.

GRAHAM ALDIS, *realtor*
Chicago

Forum:

You have covered this situation intelligently, fairly, and very completely, at least as far as large operations are concerned.

However, you do not touch upon similar situations where the question of operation and maintenance is involved, necessitating undue attention on the part of personnel whose major duties are more profitable and whose experience in building management are generally limited. Under these circumstances renting in structures furnishing necessary service is preferable in most

instances to owning or to renting a small, isolated building. Furthermore, the question of expansion and contraction is an important consideration which is generally taken care of by competent management in a multi-tenant structure. In other words, a small operation, either home office or branch, if it owns its own building, is confronted with the problem of either having a larger structure than presently required with possible consequent excess capital investment, or in a relatively short time finding itself cramped for space and facing the necessity of either abandoning the existing structure and buying a larger one or adding to it. These difficulties are generally taken care of in a multi-tenant, competently managed structure and, to my mind, constitute a very persuading argument in favor of renting.

CLARENCE M. TURLEY, *realtor*
St. Louis

CODES VS. PEOPLE

Forum:

In your February Letters department it is implied that because code enforcement puts people on the streets, code enforcement is untenable. I disagree.

Until codes are enforced, there is no point in talking about rebuilding cities. Therefore, the more people on the streets the better. It would slow irresponsible and casual migration and force the issue of dwelling standards. Some cities in other countries have enforced these standards and are slumless, while we continue to put slum exploiters above law in the naïve supposition that they are rendering some sort of public service.

When the landlord is hurt in his pocket-book and when the incentives are for rehabilitation, we will have the means to stop the slum cycle and make it worthwhile to rebuild cities. The first step is to cut our swollen cities back to legal size; if this is an impossible task then we should revise or repeal the impossible laws and take the consequences.

HARRY WEESE, *architect*
Chicago

FEES VS. PROFITS

Forum:

Your fine story on Architects Meathe, Kessler & Associates' Mount Clemens pub-

lic housing project should challenge tired architects throughout the country who let the government wear them down into bad design. The job is an outstanding group design that could well be studied with profit by private as well as public housers.

Speaking of "profit"—I would like to know what services the architects provided at 2.66 per cent and "made a profit on the job." Did this fee pay for all engineering and landscaping consultants, supervision and missionary work? If so, consulting fees and wage rates must be lower out their way or they have a new definition for "profit." Knowing that low government-set fees have kept a lot of good architects out of public housing and low fees accepted by FHA have kept them out of private housing, I wonder if there is some magic in Michigan.

CHLOETHIEL WOODWARD SMITH
Satterlee & Smith, architects
Washington, D. C.

■ Unfortunately, Architects Meathe, Kessler & Associates found no more magic in Michigan than other public housing architects have elsewhere; their profitable 2.66 per cent fee mentioned by FORUM did not include the nonarchitectural labors listed by Reader Altman below.—ED.

Forum:

Certainly the architects and the local housing authority deserve kudos for the results pictured in your February article, "Mount Clemens fresh-start housing."

However, in fairness to the much maligned Public Housing Administration and its severely criticized fee schedule, I believe that the reference to the 2.66 per cent fee deserves clarification. It is nice to make a profit at that percentage, but you might have added that the fee mentioned is exclusive of additional fees for mechanical and civil engineers, and for a landscape architect. The total fee for professional design services was probably about 3.35 per cent. The "standard fee" for architectural-engineering services on public housing jobs of scope similar to Mount Clemens can be 3.7 or 3.8 per cent.

Should even this seem low, attention might be called to the repetitive character of the work.

CHARLES B. ALTMAN, architect
Washington, D. C.

FHA SLUMS

Forum:

Bravo on your "no vacancies" editorial (FORUM, Feb. '60).

I live in one of nature's most beautiful and climatically ideal locations. However, I have long been dismayed by man's devastation of this area with plain pasteboard or stucco homes jammed together

just as close as legally possible. As a small contractor, I too am interested in profit but more concerned over this "advanced" society where quantity has assumed far more importance than quality—or significant architectural contributions.

It is gratifying that the public has begun to realize the ruinous character of our Federal Housing Administration and its programs on the building scene. In my opinion, the VA and FHA programs are the real causes of America's preoccupation with quantity.

A. DANIEL ELIASON, contractor
Mt. View, Calif.

Forum:

Your February editorial regarding responsible building is a good reminder to professional men that money is not the first criterion in making decisions.

JOSEPH PALMA JR.
Palma-Knapp Associates, designers
River Forest, Ill.

SUN-SCREEN PRISONS

Forum:

The advent of solar screen construction on the American architectural scene poses the problem of the practical vs. the esthetic. Hiding behind the subterfuge of

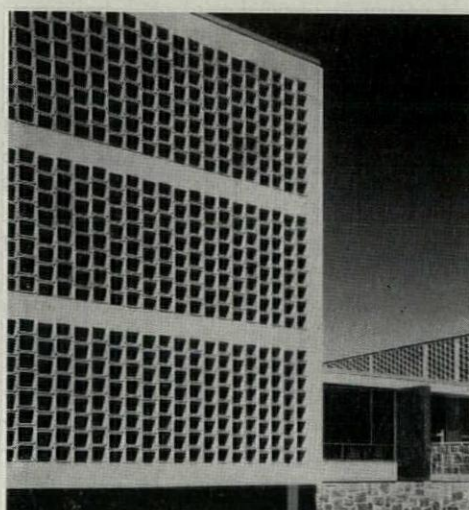

estheticism, the modern architect has taken the simplicity of geometric design and incorporated it into the solar screen (see photo, above).

It would appear that buildings are being designed on a penal institution basis; that is, escapeproof. Let no thought be given as to how the occupants can get out in case of fire or catastrophe, much less how firemen can get in to rescue anyone cut off from stair wells and other normal means of escape.

The building provisions of the Municipal Code of Chicago specifically prohibits this so-called innovation in design.

GEORGE L. RAMSEY,
commissioner of buildings
Chicago

URBAN CONTINUITY

Forum:

The January discussion of continuity in architectural and urban design clearly brings forth the shortcomings in the cooperative relationships required within groups of buildings. I believe greater emphasis should therefore be made in the architectural press on the environment in which the *chef-d'oeuvre* sits. The design emancipation which modern architects have newly gained should not encourage escape from environment, but more properly sponsor the artist's emergence from the singular work to the design of the larger scale.

OLINDO GROSSI, dean
The School of Architecture
Pratt Institute
Brooklyn

Forum:

We would appreciate 50 reprints of your feature articles "America Rebuilding" in the January 1960 issue of FORUM.

The articles were stimulating and very well done. We would like to share them with our commission members and others.

BRUCE W. MECARTNEY, planner
Saint Paul 4, Minn.

■ Reprints of FORUM's January issue are available in limited quantities for 25 cents, prepaid.—ED.

UMBRELLA SCULPTURE

Forum:

I thought your readers might be interested to know that the sculpture shown on page 117 of your February presentation of the "Umbrella House" is by Jack L. Squier. The sculpture was loaned to the owners of the house by the Whitney Museum.

ULRICH FRANZEN, architect
Rye, New York

END

ARCHITECTURAL FORUM is published monthly by TIME INC., Time & Life Building, Rockefeller Center, New York 20, N. Y.

SUBSCRIPTION SERVICE: Address all subscriptions and correspondence concerning them to: ARCHITECTURAL FORUM Subscription Dept., 540 N. Michigan Ave., Chicago 11, Ill. Subscription rates: in U.S., U.S. Possessions and Canada, one year \$6.50; elsewhere, one year \$10. Single copies, if available, \$1.

CHANGE OF ADDRESS: Four weeks is required for change of address. When ordering a change please name magazine and furnish a label from a recent wrapper. If no label is available please state as exactly as possible the address to which magazine has been sent. Changes cannot be made without old as well as new address.

EDITORIAL CORRESPONDENCE should be addressed to ARCHITECTURAL FORUM, Time & Life Building, Rockefeller Center, New York 20, N. Y. FORUM will not be responsible for unsolicited manuscripts or illustrations submitted, and it will not return such material unless accompanied by postage.

ADVERTISING CORRESPONDENCE should be addressed to the advertising director, ARCHITECTURAL FORUM, Time & Life Building, Rockefeller Center, New York 20, N. Y.

TIME INC. also publishes TIME, LIFE, FORTUNE, SPORTS ILLUSTRATED, and HOUSE & HOME. Chairman, Maurice T. Moore; President, Roy E. Larsen; Executive Vice Presidents, Howard Black, Charles L. Stillman; Administrative Vice Presidents, D. W. Brumbaugh, C. D. Jackson; Vice Presidents, Edgar R. Baker, Bernard Barnes, Clay Buckhout, Arnold W. Carlson, Allen Grover, Andrew Heiswell, J. Edward King, James A. Linn, Ralph D. Paine Jr., P. I. Prentice, Weston C. Pullen Jr.; Comptroller and Assistant Secretary, John F. Harvey.

There's no pace like **Home-Building**

Olin Aluminum is right in step with fast-moving home builders and building product manufacturers. They like us because we go all out to meet their precise schedules. Want sales-provoking alloys and finishes for siding, flashing, railings, gutters, etc.? We tailor-make the metal and speed it out. Want extrusions that cut the time and cost of producing components?  will help you design them... will make them. Looking for quality materials that cut down on job-site operations? Plenty of products fill the bill and they're made of Olin Aluminum. Call us today for a rundown on the many ways aluminum can cut your costs... improve your product... speed your sales. Your local Olin Aluminum sales office or distributor is listed in the Yellow Pages.

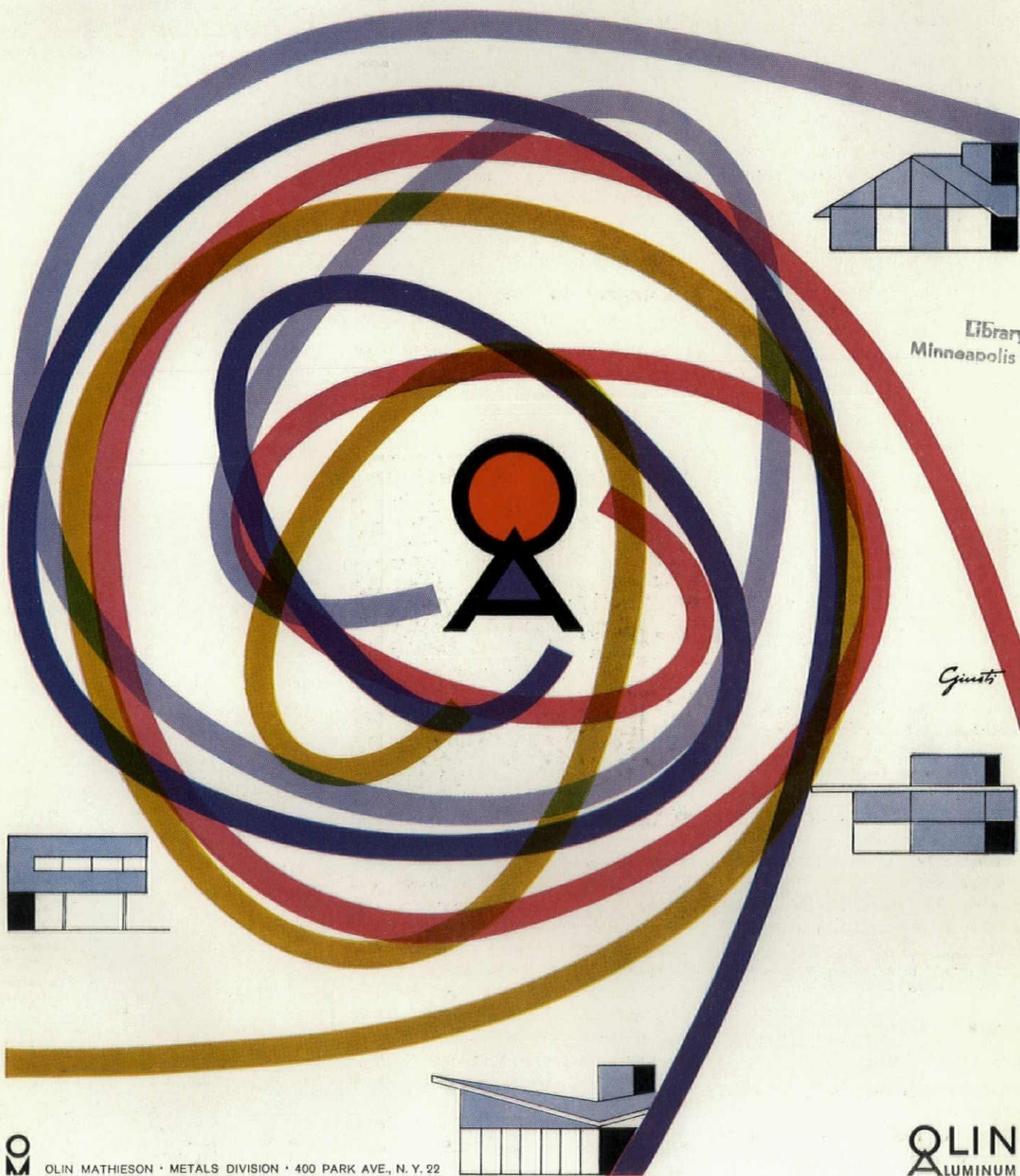

Library of the
Minneapolis School of Art

Gjants



OLIN MATHIESON • METALS DIVISION • 400 PARK AVE., N. Y. 22

OLIN
ALUMINUM

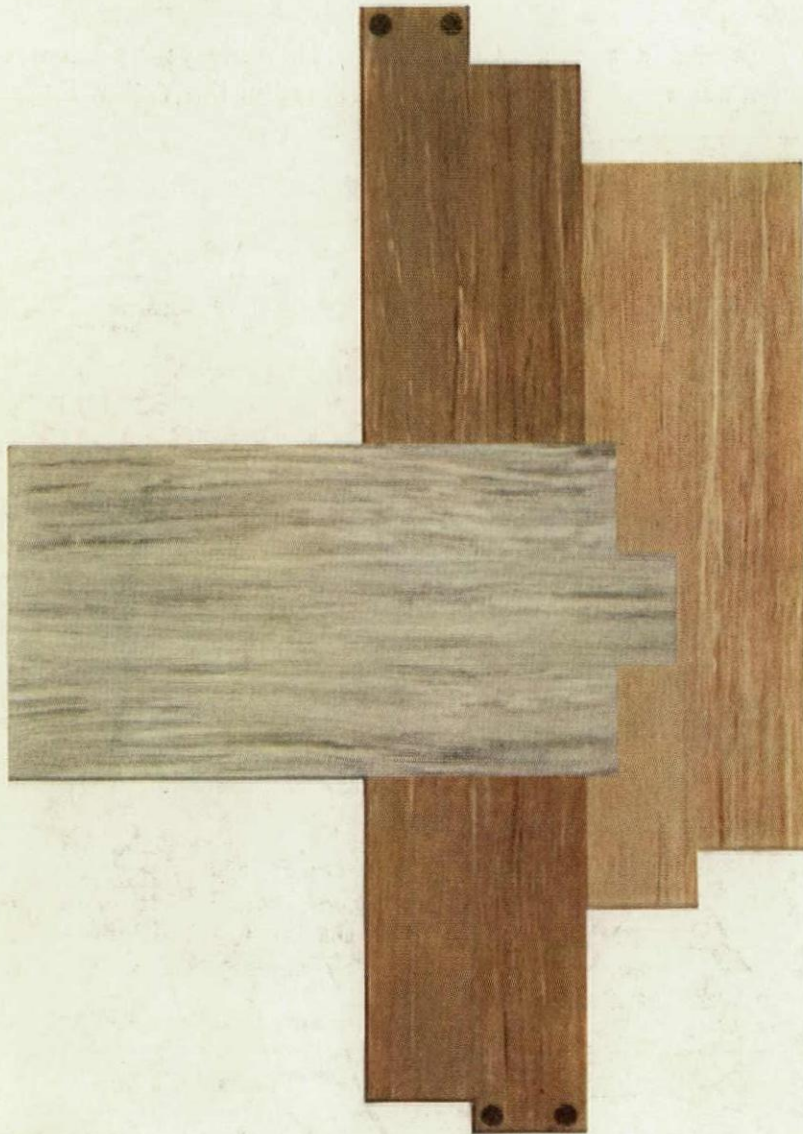

WOODGRAIN[®] RUBBER PLANKS

another exclusive style in

**KENTILE[®]
FLOORS**

... especially designed to create an atmosphere of natural wood in combination with the quiet luxury and superior wearing qualities of rubber flooring. Available plain, or pre-pegged at factory in contrasting color of your choice. For color selection, call your Kentile Representative for samples, or consult Sweet's File.

In New York, visit the Kentile Floors Showroom: Suite 3119, 31st Floor, Empire State Building, 350 Fifth Avenue.

SPECIFICATIONS Size: 4" x 36".
Thicknesses: .080" and 1/8".

* * * * *

Woodgrain Planks also available in Solid Vinyl. Woodgrain Tiles (9" x 9") available in Solid Vinyl, Vinyl Asbestos, Rubber, and Asphalt.