



**CHEMISTRY &
CHEMICAL
TECHNOLOGY**

CONFERENCE 2021 VILNIUS

16th INTERNATIONAL CONFERENCE
OF LITHUANIAN CHEMICAL SOCIETY
“**CHEMISTRY AND CHEMICAL TECHNOLOGY 2021**”

September 24, 2021, Vilnius, Lithuania

**BOOK
OF ABSTRACTS**



FIZINIŲ IR
TECHNOLOGIJOS MOKSLŲ
CENTRAS



kauno
technologijos
universitetas



TABLE OF CONTENTS

Oral presentations

O001. Richard Guy Compton. SOME ELECTRON TRANSFER REACTIONS: A FROG'S PERSPECTIVE	7
O002. Thomas Chung-Kuang Yang. RATIONAL DESIGN & NANO-ENGINEERED ASSEMBLY OF HETEROJUNCTIONS FOR VISIBLE-LIGHT-DRIVEN HETEROGENEOUS PHOTO(ELECTRO)CATALYSIS	8
O003. Aivaras Kareiva. THE PECULIARITIES OF SOL-GEL SYNTHESIS OF GARNET STRUCTURE COMPOUNDS	9
O004. Gediminas Niaura. MOLECULAR STRUCTURE OF MONOLAYERS PROBED BY VIBRATIONAL SPECTROSCOPIES	10
O005. Karl Scott Ryder. NOVEL APPROACHES TO BATTERY TECHNOLOGIES; UNDERSTANDING THE MATERIALS CHALLENGE AND ALTERNATIVES TO LITHIUM	11
O006. Linas Vilčiauskas. UNDERSTANDING AND APPLICATIONS OF NASICON-TYPE ELECTRODE MATERIALS FOR AQUEOUS NA-ION BATTERIES	12
O007. Sergei Piskunov. FIRST-PRINCIPLE CALCULATIONS FOR PHOTOCATALYTIC AND PHOTOVOLTAIC APPLICATIONS	13
O008. Vytautas Getautis. ADVANCED ORGANIC MOLECULES FOR PEROVSKITE SOLAR CELLS	14

Poster presentations

P001. Laima Kazakevičiūtė-Jakučiūnenė. DISTRIBUTION OF 137CS AND 239,240PU PHYSICO-CHEMICAL FORMS IN WATERLOGGED AND NON-BOGGY SOILS	15
P002. Edith Flora Joel. SYNTHESIS AND APPLICATION OF THIN FILMS OF GRAPHENE NANOCOMPOSITE CHITOSAN COPPER PLATINUM FOR ENVIRONMENTAL APPLICATION	16
P003. Karolina Karalevičiūtė. DEVELOPMENT AND APPLICATION OF CLAY-CHITOSAN-BASED NANOCOMPOSITES FOR SORPTION OF RADIONUCLIDES	17
P004. Nerijus Karlonas. DEVELOPMENT OF AN ANALYTICAL METHOD FOR THE DETERMINATION OF SEDATIVE-HYPNOTIC DRUGS IN BIOLOGICAL SAMPLES BY FAST GAS CHROMATOGRAPHY TECHNIQUE	18
P005. Raman Novikau. ADSORPTION OF CESIUM AND COBALT ONTO NANOCOMPOSITE BASED ON CLAY, GRAPHENE OXIDE AND MAGNETITE/MAGHEMITE	19
P006. Nataliia Tarasenko. OBTAINING HYBRID FIBROUS MATERIALS WITH ADSORPTION PROPERTIES	20
P007. Rugilė Telinskytė. EVALUATION OF ANTIBACTERIAL PROPERTIES AND PHYTOCHEMICAL COMPOSITION OF ARTEMISIA DUBIA WALL. EXTRACTS	21
P008. Maryia Drobysh. THE REVIEW OF AFFINITY SENSORS FOR THE DIAGNOSIS OF COVID-19	22
P009. Viktorija Liustrovaitė. FORMATION AND CHARACTERIZATION OF CHLOROPHYLL-A WITHIN TETHERED BILAYER LIPID MEMBRANE	23
P010. Mohamed Abdelkader. 3D PRINTED ELECTRODES FOR APPLICATIONS IN ELECTROCHEMICAL SENSING	24
P011. Katažyna Blazevič. THE APPLICATION OF SCANNING ELECTROCHEMICAL MICROSCOPY FOR THE EVALUATION OF ALCOHOL BIOSENSOR BASED ON YEAST CELLS	25
P012. Inga Gabriūnaitė. METAL OXIDE SURFACES APPLICATION FOR BIOLOGICAL MEMBRANE FORMATION	26
P013. Povilas Virbickas. APPLICATION OF PRUSSIAN BLUE IN THE DEVELOPMENT OF ENZYMATIC BIOSENSORS	27
P014. Edita Sodaitienė. APPLICATION OF WASTE MATERIAL FOR CATALYTIC DEGRADATION OF METAL COMPLEX DYE	28
P015. Virgilijus Valeika. ENZYMATIC TREATMENT INFLUENCE ON DERMATAN SULPHATE CHANGES IN HIDE	29
P016. Karolina Aleknaitė. STARCH ACETATE SORBENTS FOR REMOVAL OF PARABENS FROM AQUEOUS MEDIUM	30
P017. Karolina Almonaitytė. CATIONIC STARCH FLOCCULANTS FOR MICROALGAE BIOMASS SEPARATION	31

P018. Odeta Brigaitytė. COMPOUND FERTILIZERS GRANULATION USING BUCKWHEAT HUSK ASH	32
P019. Kristina Jančaitienė. THE INFLUENCE OF CELLULOSE ON GRANULAR PRODUCT PROPERTIES	33
P020. Rokas Klenauskis. TECHNOLOGICAL SOLUTIONS FOR CO ₂ REDUCTION IN BIOGAS	34
P021. Vesta Navikaitė-Snipaitienė. ENCAPSULATION OF EUGENOL AND THYME ESSENTIAL OIL IN STARCH SODIUM OCTENYLSUCCINATE	35
P022. Rasa Paleckienė. PREPARATION AND PROPERTIES OF COATINGS FOR FERTILIZERS SOLUBILITY CONTROL	36
P023. Kristina Ruginytė. THE INFLUENCE OF MAYENITE ADDITIVE ON THE EARLY STAGE HYDRATION OF PORTLAND CEMENT	37
P024. Rasa Šlinkšienė. PHOSPHATE FEED SUPPLEMENTS PRODUCED FROM LITHUANIAN DOLOMITE	38
P025. Virginija Valančienė. WASTE – FREE PRODUCTION OF GAS SILICATE BLOCKS	39
P026. Zenonas Valančius. PRODUCTION OF WHITE TEXTURED PAINTS USING SILICATE WASTE	40
P027. Benas Balandis. SYNTHESIS OF BENZENESULFONAMIDE-BEARING AZOLE DERIVATIVES AS HUMAN CARBONIC ANHYDRASE INHIBITORS	41
P028. Viktorija Dargytė. SYNTHESIS AND CHARACTERIZATION OF NEW POLYCYCLIC NITROGEN HETEROCYCLE COMPOUNDS VIA MULTICOMPONENT REACTIONS FROM 3- ALKOXY-1H-PYRAZOLE-4-CARBALDEHYDES	42
P029. Birutė Grybaitė. SYNTHESIS AND EVALUATION OF HYDRAZONE COMPOUNDS AS CARBONIC ANHYDRASE INHIBITORS	43
P030. Paulina Kaziukonytė. 4-ISOPROPYL-6-((1-SUBSTITUTED 1H-IMIDAZOL-5-YL)BENZENE-1,3-DIOLS AS POTENTIAL HSP90 INHIBITORS	44
P031. Rokas Žvirblis. SYNTHESIS OF TIOPHENE MODIFIED BODIPY BASED POLARITY SENSORS AND THEIR PHOTOPHYSICAL PROPERTIES IN LIPID MEMBRANES	45
P032. Miglė Babelytė. IMMOBILIZATION OF BIOACTIVE COMPOUNDS IN AMPHOTERIC STARCH DERIVATIVES	46
P033. Virginija Jakubkienė. SYNTHESIS OF PYRIMIDINES BEARING HYDROXAMIC ACID AND 1,3,4-OXADIAZOLE-2-THIONE MOIETIES AS POTENTIAL HDAC INHIBITORS	47
P034. Naveen Masimukku. ROOM-TEMPERATURE PHOSPORESCENCEBROMINE CONTAINING NAPHTHALIMIDES EXHIBITING	48
P035. Aida Šermukšnytė. SYNTHESIS AND BIOLOGICAL ACTIVITY OF ALDIMINE DERIVATIVES BEARING 1,2,4-TRIAZOLE-3-THIOLYL MOIETY	49
P036. Ingrida Tumosienė. SYNTHESIS OF AZOLES AND THEIR ANTIOXIDANT AND ANTIBACTERIAL ACTIVITY	50
P037. Rita Vaickelionienė. SYNTHESIS OF 3-((4-(N-(5-METHYLISOXAZOL-3-YL)SULFAMOYL)PHENYL)AMINO)PROPANOIC ACID DERIVATIVES	51
P038. Sandra Barysaitė. MODELING OF CONCENTRATION QUENCHING IN TWO-DIMENSIONAL SYSTEMS	52
P039. Austėja Mikalčiūtė. MODELING OF INTER-CHLOROPHYLL COUPLINGS IN THE PHOTOSYNTHETIC FCP COMPLEX	53
P040. Gabrielė Rankelytė. MODELING OF SINGLET–SINGLET ANNIHILATION IN MOLECULAR LATTICE	54
P041. Augustas Antanaitis. DEVELOPMENT OF ZINC-NICKEL 3D STRUCTURE ON TITANIUM PLATE FOR HYDROGEN PEROXIDE REDUCTION REACTION	55
P042. Aldona Balčiūnaitė. PREPARATION AND INVESTIGATION OF 3D ZINC-NICKEL COATINGS FOR OXYGEN EVOLUTION REACTION	56
P043. Greta Briedytė. ELECTROCHEMICAL FORMATION AND CHARACTERIZATION OF CALCIUM HYDROXYAPATITE ON Mg ALLOY	57
P044. Justina Gaidukevič. A NOVEL REDUCED GRAPHENE OXIDE BASED ELECTROCHEMICAL SENSOR FOR THE DETECTION OF DOPAMINE	58

P045. Zita Sukackienė. EVALUATION OF ACTIVITY OF DIFFERENT COBALT COATINGS FOR HYDROGEN EVOLUTION REACTION	59
P046. Davit Tediashvili. ROTATING RING-DISC ELECTRODE STUDY OF MANGANESE AND VANADIUM BASED MATERIAL OPERATION AND DEGRADATION AS AQUEOUS NA-ION BATTERY CATHODES	60
P047. Daina Upskuvienė. N-DOPED WOOD-DERIVED CARBON MATERIAL SUPPORTED WITH GOLD NANOPARTICLES AS AN EFFICIENT CATALYST FOR GLUCOSE ELECTRO-OXIDATION	61
P048. Eimutis Juzeliūnas. A NANOGRAVIMETRIC AND PHOTOELECTROCHEMICAL STUDY OF SILICON PASSIVATED BY ALD HAFNIUM OXIDE LAYER	62
P049. Gedvidas Bikulčius. ELECTRODEPOSITION OF TERNARY Cr-CeO ₂ /La ₂ O ₃ NANO-COMPOSITE FROM ENVIRONMENTALLY FRIENDLY Cr(III) BATH AND THEIR PROPERTIES	63
P050. Žana Činčienė. 3D STRUCTURES COPPER-NICKEL FOAMS DECORATED WITH PLATINUM PARTICLES FOR THE ELECTROOXIDATION OF SODIUM BOROXYDRIDE	64
P051. Arminas Ilginis. LEAD ELECTRODEPOSITION ON GRAPHITE FELT IN A REVERSABLE FLOW-THROUGH REACTOR	65
P052. Jolita Jablonskienė. SYNTHESIS OF CARBON-SUPPORTED MANGANESE (IV) OXIDE NANOCOMPOSITES FOR SUPERCAPACITORS APPLICATION	66
P053. Virginija Kepenienė. AuCeO ₂ /C – ENHANCED ELECTROCATALYTIC ACTIVITY FOR OXIDATION OF BOROXYDRIDE AND REDUCTION OF OXYGEN	67
P054. Aliona Kirdeikienė. PROTECTIVE AND SELF-HEALING PROPERTIES OF CERIUM-MODIFIED MOLYBDATE CONVERSION COATING ON STEEL	68
P055. Tadas Matijošius. IMPACT RESISTANCE OF ELECTROLESS Ni-P COATINGS ON ANODIZED AA6061 ALLOY	69
P056. Tadas Matijošius. EFFECTIVENESS OF FATTY ACIDS ON WEAR RESISTANCE OF ANODIC COATINGS	70
P057. Vytautas Žutautas. APPLICATION OF POLY(FOLIC ACID) FOR PH DETECTION	71
P058. Rūta Aukštakojytė. KINETICS OF GRAPHENE OXIDE THERMAL DECOMPOSITION IN THE PRESENCE OF CARBON SUBOXIDE	72
P059. Darius Budrevičius. SYNTHESIS OF CONTROLLED SIZE GdPO ₄ ·H ₂ O NANORODS	73
P060. Julija Grigorjevaitė. OPTICAL SPECTROSCOPY STUDIES OF NEW INORGANIC K ₂ Bi _{0.8} Yb _{0.2} (PO ₄)(MoO ₄) DOPED WITH Er ³⁺ PHOSPHORS	74
P061. Greta Inkrataitė. INVESTIGATION OF CERIUM AND BORON DOPED YTTRIUM AND LUTETIUM ALUMINUM GARNET CERAMICS	75
P062. Aleksej Mackevic. SYNTHESIS OF MONOPHASIC SrAl ₄ O ₇ COMPOUNDS DOPED WITH EUROPIUM AND DYSPROSIUM AND INVESTIGATION OF LUMINESCENT PROPERTIES	76
P063. Andrius Pakalniškis. INVESTIGATION OF ORTHORHOMBIC-HEXAGONAL PHASE TRANSITIONS IN HIGHLY SUBSTITUTED Lu _{1-x} Sc _x FeO ₃ SYSTEM	77
P064. Gintarė Rimkutė. SYNTHESIS AND CHARACTERIZATION OF GRAPHITE BISULFATE	78
P065. Monika Skruodienė. INVESTIGATION OF CALCIUM (II) AND VANADIUM (V) DOPED YAG PHOSPHORS	79
P066. Juras Šukys. SYNTHESIS AND CHARACTERIZATION OF La ₂ Mo ₂ O ₉ SOLID OXIDE-ION CONDUCTOR PREPARED BY AN AQUEOUS SOL-GEL METHOD	80
P067. Anastasija Afonina. LOW-TEMPERATURE SYNTHESIS OF CARBONATED HYDROXYAPATITE	81
P068. Rasa Alaburdaitė. FORMATION OF COPPER SULFIDE LAYERS ON POLYPROPYLENE BY CBD method	82
P069. Monika Baublytė. WOOD – CERAMIC COMPOSITES: SYNTHESIS AND ANALYSIS OF GdPO ₄ ·H ₂ O:Eu MODIFIED WOOD	83
P070. Ramūnas Diliautas. EFFECT OF La ³⁺ SUBSTITUTION ON PHYSICAL PROPERTIES OF BiFe _{0.85} Mn _{0.15} O ₃	84
P071. Justinas Januškevičius. SYNTHESIS OF GADOLINIUM ORTHOFERRITE THIN LAYERS	85

P072. Andrius Jaskūnas. PREPARATION OF CuO, Co ₃ O ₄ , AND Cr ₂ O ₃ CATALYSTS SUPPORTED BY 13X ZEOLITE	86
P073. Rasa Karalkevičienė. BIOCERAMIC NANO-CALCIUM HYDROXYAPATITE COATINGS ON SILICON SUBSTRATES	87
P074. Dovydas Karoblis. MOLTEN SALT SYNTHESIS OF CALCIUM MANGANITE BASED COMPOUNDS	88
P075. Greta Kazlauskaiė. INFLUENCE OF GRANITE CUTTING WASTE ON THE FORMATION OF DIBASIC CALCIUM SILICATE HYDRATES	89
P076. Agnė Kizalaitė. CHARACTERISATION OF ZINC WHITLOCKITE SYNTHESISED UNDER HYDROTHERMAL CONDITIONS	90
P077. Valentina Krylova. SEM/EDS AND XRD STUDIES OF Ag-Cd-Se THIN FILMS DEPOSITED ON POLYAMIDE 6	91
P078. Mantas Norkus. ANOMALOUS OPTICAL PROPERTIES OF YTTRIUM ALUMINUM GARNET DOPED WITH CHROMIUM	92
P079. Skirma Zalenkienė. SnS DEPOSITION BY CHEMICAL SOLUTION ROUTE	93
P080. Raminta Beresnevičiūtė. NEW STRUCTURES TADF EMITTERS FOR THIRD GENERATION ORGANIC LIGHT EMITTING DIODES	94
P081. Dovydas Blaževičius. NEW CARBAZOLE BASED HOST MATERIALS FOR THERMALLY ACTIVATED DELAYED FLUORESCENT OLEDs	95
P082. Šarūnė Daškevičiūtė. GREEN CHEMISTRY INSPIRED CARBAZOLE-FLANKED CYCLOBUTANES AS HOLE SELECTIVE MATERIALS FOR PEROVSKITE SOLAR CELLS AND MODULES	96
P083. Irina Fiodorova. SYNTHESIS AND PHOTOPHYSICAL PROPERTIES OF NOVEL PYRIMIDINEBASED DONOR-ACCEPTOR EMITTERS	97
P084. Aistė Jegorovė. CARBAZOLE DERIVATIVES AS HOLE TRANSPORTING MATERIALS FOR EFFICIENT SOLAR CELLS	98
P085. Gintarė Krucaitė. NEW ELECTROACTIVE POLYMERS WITH ELECTRONICALLY ISOLATED 4,7-DIARYLFLUORENE MATERIALS FOR OLEDs	99
P086. Maliha Parvin. SYNTHESIS OF HIGHLY POROUS PHOTOACTIVE WO ₃ FOR GENERATION OF ClO ⁻	100
P087. Justė Tamošiūnaitė. CONCENTRATION QUENCHING OF ZINC-PHTHALOCYANINE IN THIN FILMS	101
P088. Daiva Tavgenienė. PHENOXAZINES HAVING VARIOUS ELECTRON ACCEPTOR OR DONOR FRAGMENTS AS NEW HOST MATERIALS FOR PHOSPHORESCENT OLEDs	102
P089. Skirmantė Tutlienė. Na _{1±} YTi ₂ -XMX(PO ₄) ₃ (M = Al(III), Hf(IV), Mg(II), Zr(IV)) ISOVALENT AND ALIOVALENT SUBSTITUTION INFLUENCE ON AQUEOUS ELECTROCHEMICAL PROPERTIES AND ELECTRODE STABILITY	103
P090. Diana Vištorskaja. MOLYBDENUM-DOPED BISMUTH VANADATE PHOTOANODE FOR PHOTOCATALYTIC FUEL CELL	104
P091. Saulius Grigalevičius. THERMALLY CROSS-LINKABLE HOLE-TRANSPORTING MATERIAL FOR EFFICIENT SOLUTION-PROCESSED ORGANIC LIGHT EMITTING DIODES	105
P092. Algimantas Kaminskas. DEVELOPMENT OF THE GLUCOSE BIOFUEL CELL BASED ON GLUCOSE OXIDASE MODIFIED ANODE AND CATHODE	106
P093. Malek Mahmoudi. THERMALLY ACTIVATED DELAYED FLUORESCENCE OF MULTI-CARBAZOLE DERIVATIVES WITH DIFFERENT ACCPETOR MOIETIES	107
P094. Gintarė Plečkaitytė. SYNTHESIS OF Na ₃ MnPO ₄ CO ₃ AND Na ₄ Mn ₃ (PO ₄) ₂ (P ₂ O ₇) AS CATHODE MATERIALS FOR AQUEOUS NA-ION BATTERIES	108
P095. Simona Sutkuvienė. WET PROCESS FEASIBLE NOVEL FLUORENE-BASED MOLECULAR HOLE TRANSPORTING LAYER FOR PHOSPHORESCENT ORGANIC LIGHT EMITTING DIODES	109
P096. Agnė Šulčiūtė. ELECTROCHEMICAL PROPERTIES OF ELECTROPHORETICALLY DEPOSITED ZnO THIN FILMS	110
P097. Nadežda Traškina. TUNABLE CARBON COATING OF NaTi ₂ (PO ₄) ₃ FOR IMPROVED BATTERY PERFORMANCE	111

P098. Rokas Žalneravičius. ANTIMICROBIAL PROPERTIES OF SULPHUR-ENRICHED, HYDROPHILIC MoS ₂ NANO/MICROPARTICLES AND HETEROSTRUCTURED PD/MOS ₂ /TI COATINGS	112
P099. Edita Daublytė. MICROWAVE-ASSISTED SYNTHESIS OF GOLD-SILVER BIMETALLIC NANOPARTICLES	113
P100. Lena Golubeva. GRAPHENE QUANTUM DOTS AS PROMISING NANOSTRUCTURES FOR STUDYING REDOX PROCESSES IN NEUTROPHILS	114
P101. Asta Grigucevičienė. HARDNESS AND WEAR PROPERTIES OF ALD HfO ₂ LAYERS ON AZ31 ALLOY	115
P102. Aliona Klimovich. GRAPHENE QUANTUM DOT CHARACTERIZATION USING BLACK SILICON BASED SERS SUBSTRATE	116
P103. Gytautė Sirgėdaitė. EFFECT OF ULTRASONICATION ON MAGNETIC FE ₃ O ₄ NANOPARTICLES	117
P104. Konstantinas Brazinski. PREPARATION AND INVESTIGATION OF FILMS FROM PDMS AND SORBITOL MODIFIED POLYESTERS	118
P105. Marijus Jurkūnas. PHOSPHORYLCHOLINE-BASED DIBLOCK AND RANDOM BRUSH COPOLYMERS	119
P106. Liepa Pastarnokienė. SYNTHESIS OF MICROCAPSULES CONTAINING DIISOCYANATE AS A HEALING AGENT	120
P107. Kamilė Vonžodaitė. MODIFIED WITH CITRIC ACID AND PDMSSYNTHESIS AND CHARACTERIZATION OF POLYESTERS	121
P108. Lauryna Dabašinskaitė. POROUS POLYCAPROLACTONE SCAFFOLD FABRICATION FOR CARTILAGE REGENERATION VIA CRYO-ELECTROSPINNING	122
P109. Audrė Kalinauskaitė. IMPORTANCE OF MASTICATION FOR POLYISOPRENE RUBBER	123
P110. Justinas Masionis. COMBINATION OF NANO/MICRO FIBERS FOR COLLECTION OF PARTICLE MATTER	124
P111. Auksė Navaruckienė. VANILLIN ACRYLATE-BASED POLYMERS WITH ANTIBACTERIAL ACTIVITY	125
P112. Laura Pečiulytė. EFFECT OF ESTERIFICATION AGENT AND SUBSTITUTION DEGREE ON HYDROFOBICITY AND THERMAL PROPERTIES OF STARCH	126
P113. Medeina Steponavičiūtė. SYNTHESIS AND PROPERTIES OF CATIONIC CATECHOL BRUSH COPOLYMERS	127
P114. Agnė Zdaniauskienė. CHARACTERISTICS OF CEMENT SUPERPLASTICIZER BASED ON POLYMELAMINE SULPHONATE	128

Some Electron Transfer Reactions: A Frog's Perspective

Richard G Compton

Department of Chemistry, University of Oxford, Great Britain

Some electrochemical reactions will be considered at various perspectives of scale.

First, inspired by the work of Grotthuss [1] in 1806 on using colour changes adjacent to an electrode to detect local acidity and alkalinity, the use of fluorescence spectroscopy for unravelling some complex electrochemical reactions at the molecular scale will be discussed and quantitative methodological approaches outlined [2]. The development of sensors for the detection of single marine plankton will be presented and the combined use of fluorescence spectroscopy with electrochemistry shown to permit the identification of different species of plankton [3].

Second, electrochemical measurements at the scale of single entities will be discussed which allow the measurement of single enzyme chemistry and of single bacteria such as *E.coli* [4,5]. In the former case fluctuating kinetics of the catalase mediated decomposition of hydrogen peroxide into oxygen is revealed by quantitative modelling. Arising from the latter the development of an electrochemical bacteria sensor will be outlined [6].

Third, the contrasts between single entity and ensemble measurements implicit in the enzyme work [4] will trigger consideration of electron transfer reactions at electrodes modified with ensembles of particles [7]. The complications inherent in such measurements will be addressed from a simulation perspective. Implications for the evaluation of electro-catalysts will be discussed.

References

- [1] C J T de Grotthuss, Sur la décomposition de l'eau et des corps qu'elle tient en dissolution à l'aide de l'électricité galvanique', *Ann.Chim.* LVIII, 1806, 54-74 (translated to English and reprinted as *Biochimica et Biophysica Acta*, 1757, 871-875)
- [2] J Ma, M Yang, C Batchelor-McAuley and R G Compton, *PhysChemChemPhys*, 22, 2020, 12422-12433
- [3] M Yang, C Batchelor-McAuley, L Chen, Y Guo, Q Zhang, R Rickaby, H Bouman and R G Compton, *Chemical Science*, 10, 2019, 7988-7993
- [4] C Lin, L Sepunaru, E Kaetelhoeven and R G Compton, *J. Physical Chemistry Letters*, 9, 2018, 2814-2817
- [5] R Couto, L Chen, S Kuss and R G Compton, *Analyst*, 143, 2018, 4840
- [6] S Kuss, R Couto, R Evans, H Lavender, C Tang and R G Compton, *Analytical Chemistry*, 91, 2019, 4317-4322
- [7] E Kaetelhoeven and R G Compton, *Applied Materials Today*, 18, 2020, 100514

RATIONAL DESIGN & NANO-ENGINEERED ASSEMBLY OF HETEROJUNCTIONS FOR VISIBLE-LIGHT-DRIVEN HETEROGENEOUS PHOTO(ELECTRO)CATALYSIS

Sridharan Balu, Thomas Chung-Kuang Yang*

*Department of Chemical Engineering and Biotechnology, National Taipei University of Technology, Taipei-106, Taiwan (ROC). (ckyang@mail.ntut.edu.tw)

As a green and sustainable technology, semiconductor-based heterogeneous photocatalysis has received greater attention in the last several decades because it has the potential to solve both energy and environmental problems. Various hierarchical semiconductor heterojunctions/nanocomposites have been designed and fabricated at the micro/nanometer scale in recent years to synthesize efficient photocatalysts. This work presents a critical appraisal of fabrication methods, growth mechanisms, and applications of advanced hierarchical heterojunction photocatalysts. The facile synthesis strategies such as hydrothermal, microwave-assisted hydrothermal, ultrasonication, wet-chemical impregnation methods are highlighted. Finally, the as-synthesized materials were utilized for important applications, including photocatalytic degradation of pollutants and photo-electro-catalytic water-splitting (OER). The progress in photocatalysis may create new opportunities in the design of highly effective hierarchical photocatalysts for advanced applications including pollutant degradation and photoelectrochemical water-splitting to solar cells.

This presentation will summarize our efforts in (i) Enhancement of photocatalytic efficiency of novel hybrid nanocomposites, (ii) Rational and Nano-engineered fabrication of heterostructures for effective charge transfer processes, (iii) Elucidation of active species and mechanism of the synthesized photocatalysts, (iv) Applying the synthesized photocatalysts for environmental remediation and energy production applications. The 2D graphene-like morphology of g-C₃N₄ exhibits high chemical/thermal stability and serves as a promising host material for metal/non-metal doping, nanostructure regulations, semiconductor couplings, and surface modifications.

Keywords: Photocatalysts, Surface functionalization, Nanocomposites, Organic pollutants, Hazardous degradation, Photoelectrochemical, Z-scheme; type-II heterojunction.

THE PECULIARITIES OF SOL-GEL SYNTHESIS OF GARNET STRUCTURE COMPOUNDS

Aivaras Kareiva^{*}, Aldona Beganskiene

Department of Inorganic Chemistry, Vilnius University, Vilnius, Lithuania

** aivaras.kareiva@chgf.vu.lt*

Over the last few decades, sol–gel techniques have been used to prepare variety mixed-metal oxides. The sol–gel process is used to obviate the experimental difficulties and chemical inhomogeneity associated with conventional ceramic processing. In the ideal situation, the homogeneity in an amorphous gel which, on subsequent pyrolysis, yields the complex oxide directly, providing that segregation and partial crystallization can be prevented.

The compound $3\text{Y}_2\text{O}_3 \cdot 5\text{Al}_2\text{O}_3$ is referred to as yttrium aluminium garnet ($\text{Y}_3\text{Al}_5\text{O}_{12}$, YAG) and adopts the cubic garnet structure. When doped with a transition metal or lanthanide ions, YAG represents an important solid-state laser material widely used in luminescence systems, window materials for a variety of lamps and for fibre-optic telecommunication systems.

Recently, we have synthesized mixed-metal garnets of Sc^{3+} , Al^{3+} , and Ga^{3+} , by an aqueous sol–gel method. However, some garnet structures of lanthanide elements are not synthesized yet. For example, $\text{La}_3\text{Al}_5\text{O}_{12}$ phase has not formed by heat treatment of the precursor gel powders. The solid state reaction expressed by Eq. 1 does not proceed at $1000\text{ }^\circ\text{C}$ or higher temperatures [1]:

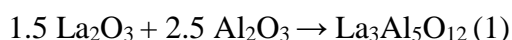

Therefore, the possible formation of ceramic composite schematically could be described by the following reaction:



or by “*phase metathesis*” reaction:

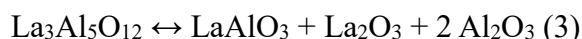

However, only one perovskite lanthanum aluminate crystalline phase was detected by X-ray diffraction analysis. Previously we predicted that probably amorphous oxides are forming even at such high temperature. Here we summarized the results on sol-gel synthesis of different garnet structure compounds, showing the dependence of formation on chemical composition of selected system [2-4].

Acknowledgements. Authors would like to thank Prof. V. Balevicius, Dr. A. Marsalka and all members of Sol-Gel Chemistry Group at Vilnius University for helpful discussions and fruitful cooperation.

References

1. R. Skaudzius, A. Zalga, A. Kareiva. *Materials Science (Medžiagotyra)*, 14 (2008) 193-197.
2. L. Pavasaryte, A. Katelnikovas, A. Momot, G. Reekmans, A. Hardy, M. Van Bael, P. Adriaensens, T. C. K. Yang, A. Kareiva. *J. Lumin.*, **212** (2019) 14-22.
3. A. Laurikenas, D. Sakalauskas, A. Marsalka, R. Raudonis, A. Antuzevics, V. Balevicius, A. Zarkov, A. Kareiva. *J. Sol-Gel. Sci. Technol.*, **97** (2021) 479-487.
4. A. Pakalniskis, A. Marsalka, R. Raudonis, V. Balevicius, A. Zarkov, R. Skaudzius, A. Kareiva. *Optic. Mater.*, **111** (2021) 110586.

MOLECULAR STRUCTURE OF MONOLAYERS PROBED BY VIBRATIONAL SPECTROSCOPIES

Gediminas Niaura^{*}, Albertas Malinauskas

Department of Organic Chemistry, Center for Physical Sciences and Technology (FTMC), Vilnius, Lithuania

** gediminas.niaura@ftmc.lt*

Adsorption at surfaces affects the structure and consequently the function of adsorbed molecules. To understand and control processes at interfaces, detailed molecular level knowledge is required. Thus, technique specific to both interface and molecular structure must be applied. Surface-enhanced Raman spectroscopy (SERS), reflection absorption infrared spectroscopy (RAIRS), and sum frequency generation (SFG) spectroscopy fulfills such requirements; being inherently surface specific these methods provide vibrational spectrum of adsorbed molecules. Thus, detailed molecular level analysis of bonding, conformation, and interaction of adsorbed molecules at interfaces is available.

The presentation will cover structural analysis of peptides, polyaniline, and self-assembled monolayers (SAMs) by surface vibrational spectroscopy methods [1–9]. Special attention will be given for in situ monitoring the potential-dependent transformation of adsorbed peptides and SAMs at electrochemical interface [1–3,5,6]. Isotopic-edited SERS coupled with first principles quantum chemical modeling of adsorption complexes considerably increases reliability of the interpretation and provides new information on structure of adsorbed species. Formation of metal-adsorbate bond between the imidazole ring and copper was evidenced by ⁶³Cu/⁶⁵Cu isotopic frequency shift and theoretical modeling. Marker bands for structure and orientation of positive charge bearing SAM of N-(6-mercapto)hexylpyridinium (MHP) were evaluated [1]. The metal-sulfur stretching bands were assigned by combined electrochemical SERS and DFT modeling. Electrostatic attraction of inorganic anions and graphene oxide by MHP was revealed. It was found that peak position of surface bound anions shifts to lower wavenumbers comparing with the solution spectrum. Interaction of methylene groups with metal surface was revealed for both adsorbed peptides and SAMs at lower surface coverage by appearance of unusually low frequency soft C–H stretching mode at 2820–2835 cm⁻¹ [2]. Specific Raman features were disclosed by the differential multiwavelength Raman spectroscopy for redox transformations of thin polyaniline films from its oxidized to semioxidized, and to reduced forms within a broad range of solution pH and electrode potential [6]. SFG spectroscopy was used to study the structure of hen egg-white lysozyme aggregates adsorbed to lipid/water and air/water interfaces [8]. It was found that aggregates with parallel and antiparallel β-sheet structure together with smaller unordered aggregates and a denatured protein are adsorbed to both interfaces. Finally, the structure of SAMs for highly efficient perovskite solar cells was revealed by SFG [9] and RAIRS methods.

References

1. I. Matulaitienė, Z. Kuodis, A. Matijoška, O. Eicher-Lorka, G. Niaura. *J. Phys. Chem. C* **119** (2015) 26481.
2. I. Razmūtė-Razmūtė, Z. Kuodis, O. Eicher-Lorka, G. Niaura. *Phys. Chem. Chem. Phys.* **12** (2010) 4564.
3. M. Talaikis, G. Valincius, G. Niaura. *J. Phys. Chem. C* **124** (2020) 19033.
4. R. Budvytytė, G. Valincius, G. Niaura, V. Voiciuk, M. Mickevičius, H. Chapman, H.Z. Goh, P. Shekhar, F. Heinrich, S. Shenoy, M. Lösche, D.J. Vanderah. *Langmuir* **29** (2013) 8645.
5. A. Zdaniauskiene, T. Charkova, I. Matulaitienė, O. Eicher-Lorka, A. Matijoška, M. Skapas, A. Selskis, G. Niaura. *J. Phys. Chem. C* **122** (2018) 1234.
6. R. Mažeikienė, G. Niaura, A. Malinauskas. *J. Solid State Electrochem.* **23** (2019) 1631.
7. G. Niaura, Z. Kuprionis, I. Ignatjev, M. Kažemėkaitė, G. Valincius, Z. Talaikytė, V. Razumas, A. Svendsen. *J. Phys. Chem. B* **112** (2008) 4094.
8. S. Strazdaite, E. Navakauskas, J. Kirschner, T. Sneideris, G. Niaura. *Langmuir* **36** (2020) 4766.
9. A. Magomedov, A. Al-Ashouri, E. Kasparavičius, S. Strazdaite, G. Niaura, M. Jošt, T. Malinauskas, S. Albrecht, V. Getautis. *Adv. Energy Mater.* **8** (2018) 1801892.

NOVEL APPROACHES TO BATTERY TECHNOLOGIES: UNDERSTANDING THE MATERIALS CHALLENGE AND ALTERNATIVES TO LITHIUM

Karl S. Ryder^{*,1}, Anthony Lucio¹

¹ *Materials Centre, School of Chemistry, University of Leicester, Leicester LE1 7RH, UK*

** k.s.ryder@le.ac.uk*

The rapidly increasing demand for rechargeable battery systems in order to power stationary energy storage, mobile electronics and electric vehicles has generated acute technical and social challenges. Much recent effort has focused on lithium-, sodium-, and magnesium-based battery technologies, with lithium-ion batteries (LIB) dominating the current market share. Although LIBs are widely used in everyday technology they possess significant drawbacks that limit their application *e.g.* geopolitical supply sensitivity of critical raw materials, difficulty in recycling used battery systems,¹ and safety concerns.² As a result, there are major efforts to develop battery systems to compete and replace the current technology. Even if new battery chemistries cannot match LIB performance metrics, the possibility of cheaper, safer and more environmentally friendly options are highly attractive.

One very encouraging option is aluminium-based batteries.³ Aluminium is economically inexpensive, highly abundant and possess an energy density almost as good as Li. Like Li, however, Al systems require non-aqueous electrolyte chemistries, as the reduction potential of Al is more negative than the evolution of hydrogen in aqueous-based electrolytes. The development of non-aqueous electrolytes for Al battery systems has subsequently received significant attention with much of this focused on the study of ionic liquids. However, most ionic liquids remain prohibitively expensive and are often difficult to handle.

Here we present the study of novel ionic liquid analogue (ILA) electrolytes for aluminium electrodeposition that are based on salts of amidine Lewis bases.⁴ The ILA electrolytes exhibit reversible voltammetric plating / stripping of Al, good ionic conductivity (10 – 14 mS cm⁻¹) and relatively low viscosities (50 – 80 cP). The observed rheological properties are an improvement on analogous amide-based ILAs and make these liquids credible alternatives to other ILAs based on urea or acetamide, or conventional chloroaluminate ILs for Al battery applications. We will describe the rheological and electrochemical properties of these electrolytes, including a study using QCM microgravimetry, in comparison to some of the other alternatives and speculate on the value of these systems to a new cell technology.

This work was funded by the EU H2020-FETOPEN-1-2016-2017 G.A. 766581 SALBAGE and FET-PROACT-EIC-06-2019 G.A. 951902 AMAPOLA projects.

References

1. G. Harper, R. Sommerville, E. Kendrick, L. Driscoll, P. Slater, R. Stolkin, A. Walton, P. Christensen, O. Heidrich, S. Lambert, A. Abbott, K. Ryder, L. Gaines and P. Anderson, *Nature*, (2019), **575**, 75-86.
2. G. A. Elia, K. V. Kravchyk, M. V. Kovalenko, J. Chacón, A. Holland and R. G. A. Wills, *Journal of Power Sources*, (2021), **481**, 228870.
3. K. V. Kravchyk and M. V. Kovalenko, *Communications Chemistry*, (2020), **3**, 120.
4. Anthony J. Lucio, Igor Efimov, Oleg N. Efimov, Christopher J. Zaleski, Stephen Viles, Beata B. Ignatiuk, Andrew P. Abbott, A. Robert Hillman, and Karl S. Ryder, *Chem. Commun.*, (2021), *submitted*.

UNDERSTANDING AND APPLICATIONS OF NASICON-TYPE ELECTRODE MATERIALS FOR AQUEOUS NA-ION BATTERIES

Linas Vilčiauskas^{1*}

¹ *Center for Physical Sciences and Technology (FTMC), Saulėtekio al. 3, LT-10257 Vilnius, Lithuania*

** E-mail: Linas.Vilciauskas@ftmc.lt*

Aqueous Na-ion batteries (ASIB) are one of the potential promising candidates for future stationary energy storage systems. NAtrium Super Ionic CONductor (NASICON) structure type materials are a very attractive class of ASIB electrode materials due to their great structural stability, fast ionic conductivity and great selection of redox potentials. However, there is still a number of issues to be solved before their full potential can be utilized. In addition to finding suitable new electrode materials there are also issues related to the stability of these materials in aqueous electrolyte solutions, morphological control and optimization etc. In my talk, I would like to present some of our recent contributions towards the understanding and applications of NASICON-type electrode materials for use in ASIBs.

Various NASICON structured phosphates such as $\text{NaTi}_2(\text{PO}_4)_3$, $\text{Na}_{1+2x}\text{Mn}_x\text{Ti}_{2-x}(\text{PO}_4)_3$ ($0.0 < x < 1.5$) or $\text{Na}_{3-x}\text{V}_{2-x}\text{Ti}_x(\text{PO}_4)_3$ ($0.0 < x < 1.0$) are prepared using a wide range of synthesis routes such as solid-state, sol-gel, solvothermal. Their structure, morphology and chemical composition is characterized by XRD, SEM, Raman, XPS, TEM, TGA, DTA, ICP-OES techniques. Electrochemical characterization is performed by CV, GCD, EIS, RRDE methods. A wide range of computational techniques such as DFT and cluster expansion are employed for fundamental understanding of atomic structure and energetics.

Acknowledgements: This project has received funding from the European Regional Development Fund (Project No. 01.2.2-LMT-K-718-02-0005) under a grant agreement with the Research Council of Lithuania (LMTLT).

References

1. D. Gryaznov et al. *Phys. Chem. Chem. Phys.*, **22** (2020) 11861.
2. Plečkaitytė et al. *J. Mater. Chem A*, **9** (2021) 12670.
3. Tutlienė et al. *J. Electrochem Soc.* **168** (2021) 060545.

FIRST-PRINCIPLE CALCULATIONS FOR PHOTOCATALYTIC AND PHOTOVOLTAIC APPLICATIONS

Sergei Piskunov^{*}, In-Bai Lin, Inta Isakoviča, Dmitry Bocharov

Institute of Solid State Physics, University of Latvia, Riga, Latvia

** piskunov@cfi.lu.lv*

Due to the world's growing population and industrialization, the demand for energy is also increasing. Using fuels as an energy source produces greenhouse gases, which have a detrimental effect on the environment, especially global warming [1-3]. To mitigate this problem, it is important to develop alternative clean energy sources that can fulfill the energy demand. Harnessing energy directly from sunlight is one option to fulfill the need for clean energy and simultaneously have a negligible environmental effect [4]. Solar energy can be utilized in photovoltaic applications to generate electricity and to split water to produce hydrogen. Developing suitable photocatalysts for photovoltaic [5,6] and water splitting reaction [7], is an important step toward harnessing solar light efficiently.

In this presentation we overview an approach allowing us modelling of photocatalyzed and photovoltaic reactions on surfaces of semiconducting TiO₂ (nano)materials, used here as an example. Our approach is based on density functional theory (DFT) and time-dependent DFT (TDDFT) that explicitly accounts for the evolution of one-electron excited states. TDDFT for excited-state calculations involving single excitations to define absorption spectra of catalyst, as well as for simulation of charge transfer processes at the surface of TiO₂ (nano)materials. Our calculations describe a large fraction of the processes occurring catalyst/water interface. These processes initiate at excitation and eventually result in charge separation, delocalization, and relaxation. They are accompanied by electron/hole trapping near the surface and their transfer back to the electrode (photoabsorber) or to the electrolyte. From our calculations we predict the possibility of hole-mediated splitting of molecularly adsorbed water on the surface of TiO₂ (nano)materials. In our study we show a general computational strategy for describing photoexcited oxide/adsorbate interfaces and also demonstrate that the occurrence of water dissociation on the TiO₂ (nano)materials depends sensitively on the local atomic environment and external parameters such as temperature.

This research was funded by the M-ERA.NET project “Multiscale computer modelling, synthesis and rational design of photo(electro)catalysts for efficient visible-light-driven seawater splitting” (CatWatSplit).

References

1. A.J. Nozik, Photoelectrochemistry: applications to solar energy conversion, *Annu. Rev. Phys. Chem.* **29** (1978) 189-222.
2. N.S. Lewis, Powering the planet, *MRS Bull.* **32** (2007) 808-820.
3. D.G. Nocera, Personalized energy: the home as a solar power station and solar gas station, *ChemSusChem* **2** (2009) 387-390.
4. H. Wei, D. Cui, J. Ma, L. Chu, X. Zhao, H. Song, H. Liu, T. Liu, N. Wang, Z. Guo, Energy conversion technologies towards self-powered electrochemical energy storage systems: the state of the art and perspectives, *J. Mater. Chem. A* **5** (2017) 1873-1894.
5. M. Moniruddin, B. Ilyassov, E. Seliverstova, Y. Shabdan, N. Bakranov, N. Ibrayev, N. Nuraje, Bioinspired study of energy and electron transfer in photovoltaic system, *J. Exp. Nanosci.* **12** (2017) 285-296.
6. Y. Shabdan, A. Ronasi, P. Coulibaly, M. Moniruddin, N. Nuraje, Engineered core-shell nanofibers for electron transport study in dye-sensitized solar cells, *AIP Adv.* **7** (2017) 065008.
7. S.Z. Islam, A. Reed, D.Y. Kim, S.E. Rankin, N₂/Ar plasma induced doping of ordered mesoporous TiO₂ thin films for visible light active photocatalysis, *Microporous Mesoporous Mater.* **220** (2016) 120-128.
8. S. Piskunov, O. Lisovski, J. Begens, D. Bocharov, Yu.F. Zhukovskii, M. Wessel, and E. Spohr, C-, N-, S-, and Fe-doped TiO₂ and SrTiO₃ nanotubes for visible-light-driven photocatalytic water splitting: Prediction from first principles. *J. Phys. Chem. C* **119** (2015) 18686-18696.
9. S. Kenmoe, O. Lisovski, S. Piskunov, Yu.F. Zhukovskii, E. Spohr. Electronic and optical properties of pristine, N- and S-doped water-covered TiO₂ nanotube surfaces. *J. Chem. Phys.* **150** (2019) 041714.

ADVANCED ORGANIC MOLECULES FOR PEROVSKITE

SOLAR CELLS

Vytautas Getautis

Department of Organic Chemistry, Kaunas University of Technology, Kaunas, Lithuania
vytautas.getautis@ktu.lt

The application of solar cells is one of the most promising solutions for satisfying the ever-increasing global energy demand. Recently, organic-inorganic hybrid lead halide perovskite solar cells (PSCs) are gathering attention and have emerged as an extremely promising photovoltaic technology due to their remarkable photovoltaic performance and potentially low production cost [1]. To date, progress has been made on each layer, with major emphasis on perovskite film processing and relevant material design. Since 2009, when Miyasaka and coworkers reported a 3.8% power conversion efficiency (PCE) of PSCs [2], the performance of these photovoltaic devices has increased dramatically and currently, PCE exceeds 25% [3].

A typical conventional PSC consists of a lead-halide perovskite layer sandwiched by an electron-selective layer and an organic hole-selective material, which is an important counterpart to produce high efficiency due to effective hole extraction/collection and electron blocking from the perovskite to the metal anode. Despite significant efforts dedicated towards development of new hole transporting materials the field is still dominated by costly 2,2',7,7'-tetrakis(*N,N*-di-*p*-methoxyphenylamino)-9,9'-spirobifluorene (Spiro-OMeTAD). High cost of Spiro-OMeTAD arises from the prohibitively expensive synthesis and purification procedures used.

This lecture will cover results of our recent investigations in the field of molecular engineering of small molecule hole transporting materials for perovskite solar cells. Our group has been successful in creating several classes of novel organic charge transporting materials, which are on a par with or even better than Spiro-OMeTAD. The molecularly engineered new hole transporting materials were synthesized in one or two steps from commercially available and relatively inexpensive starting reagents, resulting in up to several fold cost reduction of the final product compared with Spiro-OMeTAD. High solubility in organic solvents and ease of preparation makes these molecules very appealing for commercial prospects of photovoltaic devices.

References

1. Y. Rong, Y. Hu, A. Mei, H. Tan, M. I. Saidaminov, S. S. Il, M. D. McGehee, E. H. Sargent, H.; Han. Science **361** (2018) No. eaat8235.
2. A. Kojima, K. Teshima, Y. Shirai, T. Miyasaka, J. Am. Chem. Soc. **131** (2009) 6050.
3. Best Research-Cell Efficiency Chart. Photovoltaic Research. NREL (2021): <https://www.nrel.gov/pv/cell-efficiency.html>

ANALYSIS OF ^{137}Cs AND $^{239,240}\text{Pu}$ DISTRIBUTION IN PHYSICOCHEMICAL FORMS OF WATERLOGGED AND NON-BOGGY SOIL

Laima Kazakevičiūtė-Jakučiūnė, Evaldas Maceika, Nikolay Tarasyuk, Rūta Druteikienė, Rasa Gvozdaitė, Zita Žukauskaitė, Šarūnas Buivydas

A State Research Institute Center for Physical Sciences and Technology, Savanorių ave. 231, LT-02300 Vilnius, Lithuania

laima.kazakeviciute@ftmc.lt

Sequential extraction is a widely used technique for determining the solid speciation of a trace metal or radionuclide, which explains under what chemical or physical conditions the metal will be remobilised. The technique utilises a succession of chemical extractants, chosen to selectively dissolve the various geochemical phases likely to be affected by changes in environmental conditions within the sediment or the surrounding water. Metals and radionuclides associated with a given phase will be released upon dissolution of the host phase (Lucey et al. 2004). Sequential extraction technique, in which the sediment or soil is separated into defined, sequentially-dissolved phases via a series of increasingly aggressive chemical extractions, can be used to determine their geochemical associations indirectly. This can provide useful information on the potential migration of the radionuclides in soils (Kimber et al 2015).

Two samples of non-boggy and waterlogged soils were taken in an untouched place near the lake Bedugnis, which is located in Varėna district. Physicochemical forms of tested radionuclides were studied in soil layers with maximum concentrations of the radionuclides since their content may be considered as the main source of further vertical migration of radionuclides. In both cases, maximum concentrations of the radionuclides were obtained at the same depth (6-8 layers).

The geochemical forms of Pu and ^{137}Cs as well as their migration opportunities in waterlogged and non-boggy soils significantly differ. Thus, in waterlogged soil where anaerobic conditions are usually formed, the most part of radiocesium (~99 %) was bound in the residue due to the presence of clay materials and its migration opportunities were restricted. In contrary, the greatest migration opportunities of radiocesium were found in non-boggy soil under aerobic conditions. Thus, in the non-boggy soil core (6-8 layers), its exchangeable fractions varied in the range of 10.1 – 12.2 %. A radiocesium part in the residue amounted only ~61 - 71 %.

In the studied layers of non-boggy soil, most of the $^{239,240}\text{Pu}$ was in the oxide fraction (~45 - 54 %), lower in the residual (~23 - 40 %) fraction and then in the exchangeable one (~3 %). In contrary, in the same layers of the waterlogged soil core, the most part of the $^{239,240}\text{Pu}$ was concentrated in the organic matter fraction (49-53 %), less in the residual (16 - 28 %), oxide (12 - 16 %) fractions and in the exchangeable (10 - 14 %) fraction. The latter indicates a large migration capacity of plutonium under anoxia conditions and that absorption of $^{239,240}\text{Pu}$ by clay materials is not a dominant factor. This means that in the studied soils in the area of Lake Bedugnis the radionuclide mobilizing factors act as opposite for radiocesium and plutonium. Most of the stable elements were accumulated in the residual, organic matter and the oxide fractions. The distribution of Al in waterlogged soil was very similar to that of $^{239,240}\text{Pu}$ (organic fraction > oxide and residual fractions).

The results of this study indicate that the physicochemical forms of radionuclides in the soil are an indicator of their mobile capabilities and this method can be applied to the assessment of radionuclide migration potential of the contaminated area in different soils.

References :1. Lucey J A, Gouzy A, Boust D, Vintro L L, Bowden L, Finegana P P, Kershaw P J, Mitchell P I. 2004.. Appl Radiat Isot 60: 379–385..

2. Kimber R L, Corkhill C L, Amos S, Livens F R, Lloyd J R. 2015.. J Environ Radioact 142: 96-102.

SYNTHESIS AND APPLICATION OF THIN FILMS OF GRAPHENE NANOCOMPOSITE CHITOSAN COPPER PLATINUM FOR ENVIRONMENTAL APPLICATION

Edith Flora Joel^{*}, Galina Lujanienė¹, Sandra Stanionytė¹, Martynas Skapas¹, Loreta Leviskaitė²

¹ SRI Center for Physical Sciences and Technology, Lithuania

² SRI Nature Research Centre, Vilnius, Lithuania

edith.joel@ftmc.lt

The non-toxicity of Chitosan when mixed with other metal composites can have a wide application of environmental application owing to its high biodegradability. On the other hand, graphene oxide is known for its mechanical strength as well as excellent chemical and physical properties. Although graphene oxide has high potential for applications in the environment sector, due to some limitations associated with its characteristics, Graphene Oxide-chitosan nanocomposites have found wide application in solving environmental issues [1]. Metal nanoparticles like platinum and copper and their oxides are known for their enhanced anticorrosive and adsorption properties [2]. Chitosan-graphene oxide-platinum-copper nanocomposites and its oxides immobilized on a thin chitosan film have been synthesized for the first time. Firstly, Graphene Oxide nanoparticles are obtained by a modified Hummers method. Chitosan oxide composite thin films were prepared by mixing an aqueous solution of 3% chitosan and 1.5 g of graphene oxide in the presence of diluted 1 % acetic acid [3].

The Copper (Cu), Copper oxide (CuO), Cuprous Oxide (Cu₂O) and Copper (I) perOxide(Cu₂O₂) were synthesised in the laboratory conditions by the reduction of copper sulphate pentahydrate. Later the platinum and copper / copper oxide nanoparticles were added to the synthesized graphene-oxide chitosan aqueous solution and ultrasonication was done so that the oxygen-containing functional groups attract the platinum by electrostatic interaction [4]. The structural properties and swelling test, were performed to analyse the physical characteristics of the thin films. Finally, copper nanoparticles were also added along with the homogenous solution of Graphene Oxide-chitosan-platinum and sonication is completed and left overnight. The copper nanoparticles and the graphene oxide/chitosan nanoparticles were characterised by EDAX, XRD. After this, the films GO-CS-Pt-Cu, GO-CS-Pt-CuO, GO-CS-Pt-Cu₂O, GO-CS-Pt-Cu₂O₂ were fabricated by the gel casting method aided by the self-healing ability of the chitosan framework. In conclusion, our studies form the basis for the prospective use of these nanocomposites as potential agents for antibacterial, cleaning, anticorrosion, and other environmental applications.

REFERENCE:

1. Menazea, Abdelrahman A., et al. "Chitosan/graphene oxide composite as an effective removal of Ni, Cu, As, Cd and Pb from wastewater." *Computational and Theoretical Chemistry* 1189 (2020): 112980.
2. Nzaba, Sarre MK, Bhekie B. Mamba, and Alex T. Kuvarega. "Platinum Group Metal-Based Nanocatalysts for Environmental Decontamination." *Nanocatalysts* (2019).
3. Han, Donglin, et al. "Preparation of chitosan/graphene oxide composite film with enhanced mechanical strength in the wet state." *Carbohydrate Polymers* 83.2 (2011): 653-658.
4. Lu, Yang, et al. "Facile synthesis of graphene-like copper oxide nanofilms with enhanced electrochemical and photocatalytic properties in energy and environmental applications." *ACS applied materials & interfaces* 7.18 (2015): 9682-9690.

DEVELOPMENT AND APPLICATION OF CLAY-CHITOSAN-BASED NANOCOMPOSITES FOR SORPTION OF RADIONUCLIDES

Karolina Karalevičiūtė^{1,2}, Galina Lujanienė², Vidas Pakštas³

¹ *Department of Analytical and Environmental Chemistry, Faculty of Chemistry and Geosciences, Vilnius University, Lithuania*

² *Department of Environmental Research, Center for Physical Sciences and Technology, Lithuania*

³ *Department of Characterisation of Materials Structure, Center for Physical Sciences and Technology, Lithuania*
karolina.karaleviciute@chgf.stud.vu.lt

Nowadays, the main sources of environmental pollution are waste products of the various industrial enterprises. In this regard, the unique properties of natural minerals such as economic availability, ubiquity, chemical stability and their low cost have resulted in an increasing interest in their investigation and widespread application [1,2]. Clays and their minerals are a widespread and cheap material that has been successfully used for decades as an adsorbent for removing toxic heavy metals from aqueous solutions [3]. Clays and their minerals, both natural and modified have been used for environmental protection, industrial and medical applications. Clays often have very high surface area and cation exchange capacity that make them very useful for carrying several kinds of substances [4].

The aim of this study was to prepare clay-chitosan composites as an adsorbent with various clay concentrations and modifications, in order to apply them for sorption of radionuclides.

In this research, chitosan powder was dissolved in 100 ml of an aqueous solution of acetic acid (1%, v/v), using a magnetic stirring plate at 90°C and 150 rpm for 1 hours and then cooling the solution to room temperature. In this study natural clay containing muscovite and two commercial minerals were used. Chitosan-clay composites were obtained by mixing the chitosan with different amounts of clay. The resulting composites were subjected to various chemical modifications. The obtained composites were applied for the sorption of cesium and cobalt. The adsorption of Cs(I) to composites was studied at pH from 3 to 9 at initial concentration of 3 g/L as well as at the Cs initial concentrations of 3, 6 and 10 g/L. Preliminary tests were performed to estimate applicability of nanocomposites for cobalt sorption. Cs(I) solutions were traced with ¹³⁷Cs, while Co(II) solutions with ⁶⁰Co. Cs(I) and Co(II) activity concentrations were measured by gamma spectrometry using a HPGe detector (resolution 1.9 keV/1.33 Mev and efficiency 42%). The values of the chitosan-clay composite adsorption capacities varied as follows: from 52 to 482 mg/g at pH 3; from 246 to 688 mg/g at pH 5; from 415 to 1048 mg/g at pH 7; from 369 to 977 mg/g at pH 8 and from 297 to 1073 mg/g at pH 9.

[1] Biswas S., Rashid T.U., Debnath T., Haque P. 2020. Application of Chitosan-Clay Biocomposite Beads for Removal of Heavy Metal and Dye from Industrial Effluent, 1–14. DOI: 10.3390/jcs4010016.

[2] Shehap A.M., Nasr R.A., Mahfouz M.A., Ismail A.M. 2021. Preparation and characterizations of high doping chitosan/MMT nanocomposites films for removing iron from ground water, Journal of Environmental Chemical Engineering 9(1): 104700. DOI: 10.1016/j.jece.2020.104700 .

[3] Neji A.B., Jridi M., kchaou H., Nasri M., Dhoub Sahnoun R. 2020. Preparation, characterization, mechanical and barrier properties investigation of chitosan-kaolinite nanocomposite, Polymer Testing 84(October 2019): 106380. DOI: 10.1016/j.polymertesting.2020.106380.

[4] Marrakchi F., Hameed B.H., Hummadi E.H. 2020. Mesoporous biohybrid epichlorohydrin crosslinked chitosan/carbon-clay adsorbent for effective cationic and anionic dyes adsorption, International Journal of Biological Macromolecules 163: 1079–1086. DOI: 10.1016/j.ijbiomac.2020.07.032 .

DEVELOPMENT OF AN ANALYTICAL METHOD FOR THE DETERMINATION OF SEDATIVE-HYPNOTIC DRUGS IN BIOLOGICAL SAMPLES BY FAST GAS CHROMATOGRAPHY TECHNIQUE

Nerijus Karlonas

*The State Forensic Medicine Service, Toxicology Laboratory, Didlaukio 86E, LT-08303 Vilnius, Lithuania
nerijuskarlonas@yahoo.com*

When developing a fast gas chromatography with negative-ion chemical ionization mass spectrometry (GC/NICI-MS) method matrix effects are a major issue. The effect of co-eluting compounds arising from the matrix can result in signal enhancement or suppression [1-3]. During the method development, much attention should be paid to diminish matrix effects as much as possible. The present work evaluates matrix effects from blood and urine samples in the simultaneous analysis of fifteen benzodiazepines.

Therefore, the main aim of my study was to develop a new sensitive and specific analytical method based on a fast GC/NICI-MS using a mixed-mode solid-phase extraction (SPE) for the identification and quantification of these drugs in biological samples. Moreover, the speed of the analytical separation was emphasized by modifying various GC/NICI-MS parameters. The fully validated analytical method was applied for the quantification of several benzodiazepines in real blood and urine samples.

The proposed GC/NICI-MS method coupled with a mixed-mode SPE (a strong cation-exchange polymeric sorbent) and derivatization by N-(tert-butyldimethylsilyl)-N-methyl trifluoroacetamide:acetonitrile:ethyl acetate mixture (20:40:40 (v/v/v)) was shown to be useful for the analysis of benzodiazepines in biological samples. A derivatization step using different silylation reagents, duration, and temperature was investigated. This method is the fastest among the others reported up to now [1,2]. Under the optimized GC conditions derivatives of analytes were completely separated within 3.9 min. Sensitive and specific NICI-MS detection combined with fast GC resulted in a sharp and symmetric peak shape of the target analyte while maintaining sufficient resolution. Sample preparation conditions including a selection of the solvent for washing and elution steps, pH values were also optimized. To the best of my knowledge, this method has been used for the first time for the optimization of sample preparation at pH 1.0.

The developed method for fifteen benzodiazepines determination in biological samples was validated following the recommendation for new methods [1,2]. The linear relationships with the correlation coefficients (r^2) better than 0.9960 were evaluated. It was determined that extraction efficiency ranged from 82.9 (± 6.2) % to 94.6 (± 3.4) %. The precision (RSD) for benzodiazepines was 4.08 - 9.52 %, while the accuracy was in the range of 93.0 - 106.3 %. The developed method provides significant advantages in comparison with other previously published methods [1-3]. It shows higher sensitivity (the limit of detection ≤ 0.62 ng mL⁻¹) in biological samples. Moreover, this method has several advantages: elimination of interferences, low-volume of samples (0.2 mL), and a multi-residue analysis. According to the results, the developed GC/NICI-MS-SPE method is accurate, sensitive, and specific enough to detect analytes after a long time use of a single oral administration of some drugs. Furthermore, this method enables to reach the highest specificity for major analytes and meets the requirements of good laboratory practice, especially when applied to pharmacodynamic investigations. Ultimately, the developed method has been applied in routine toxicological analysis during the investigation of both clinical and forensic cases.

References

1. V. F. Samanidou, M. N. Uddin, I. N. Papadoyannis. *Bioanalysis*. **1** (2009) 755-784.
2. K. Persona, K. Madej, P. Knihnicki, W. Piekoszewski. *J. Pharm. Biomed. Anal.* **113** (2015) 239-264.
3. N. Karlonas, A. Padarauskas, A. Ramanavicius, A. Ramanaviciene. *J. Sep. Sci.* **36** (2013) 1437-1445.

ADSORPTION OF CESIUM AND COBALT ONTO NANOCOMPOSITE BASED ON CLAY, GRAPHENE OXIDE AND MAGNETITE/MAGHEMITE

Raman Novikau^{1*}, Galina Lujanienė¹, Vidas Pakštas², Martynas Talaikis³,
Audrius Drabavičius², Arnas Naujokaitis², Sergej Šemčuk¹

¹*Department of Environmental Research, Center for Physical Sciences and Technology, Vilnius, Lithuania*
**raman.novikau@ftmc.lt*

²*Department of Characterisation of Materials Structure, Center for Physical Sciences and Technology, Vilnius, Lithuania*

³*Department of Organic Chemistry, Center for Physical Sciences and Technology, Vilnius, Lithuania*

Nuclear weapons tests, man-made disasters, for example, at the Chernobyl [1] and Fukushima-Daiichi nuclear power plants [2], as well as unintentional leaks, spills during the operation of nuclear facilities lead to environmental pollution with radionuclides and, as a consequence, a violation its integrity and negative impact on human health [3-5]. It is assumed that clay minerals and their composites play an important role in protecting the environment from the negative effects of radionuclides. Nowadays, clay minerals in terms of adsorption efficiency are not inferior to commercial adsorbents, and in some cases even surpass them. Clays are actively modified in order to increase their efficiency and selectivity in relation to pollutants. Combinations with clays, in the composition of the composite, other potential adsorbents, makes it possible to increase the efficiency of adsorption due to a synergistic effect, in addition, clays reduce the toxic effect of other components in the composition of the composite, for example, graphene oxide [6].

The aim of this study was to develop a Clay-Graphene Oxide (GO)-Magnetite (MG)/Maghemite (MGH) nanocomposite, as well as to study the adsorption behaviour of Cs(I) and Co(II) on this nanocomposite. The first step of preparation of the nanocomposite included the synthesis of individual components – GO and MG/MGH, the GO was obtained by the Hummers method, the MG/MGH by a co-precipitation reaction of ferrous and ferric ions. The synthesis of the nanocomposite included dispersing GO and MG/MGH in an ultrasonic bath for 2 h, followed by the addition untreated triassic clay (Šaltiškiai in North Lithuania) to the solution, keeping the mixture under constant stirring in a flow of argon for 1.5 hours, at 60 °C. Then this mixture is centrifuged, the resulting nanocomposite is taken and dried in vacuum for 24 hours. These nanocomposites were characterized using X-ray diffraction analysis (XRD), X-ray fluorescence analysis (XRF), scanning electron microscope (SEM), transmission electron microscope (TEM) and fourier-transform infrared spectroscopy (FTIR). To study the adsorption behaviour of Cs(I) and Co(II), various tests were carried out, depending on the concentration of the adsorbent and adsorbate, pH, temperature, contact time, as well as the adsorption of these metals in a binary system. The resulting nanocomposite proved to be effective in adsorption of Cs(I) and Co(II), where the maximum adsorption capacity was 2165 mg/g and 627 mg/g.

References

1. IAEA (International Atomic Energy Agency), 2006. Environmental Consequences of the Chernobyl Accident and Their Remediation: Twenty Years of Experience. Report of the Chernobyl Forum Expert Group 'Environment'. International Atomic Energy Agency Vienna, Austria.
2. Sahoo, S.K., Kavasi, N., Sorimachi, A., Arae, H., Tokonami, S., Mietelski, J.W., Lokas, E., Yoshida, S., 2016. Strontium-90 activity concentration in soil samples from the exclusion zone of the Fukushima daiichi nuclear power plant. *Sci. Rep.* **6**, 1–10.
3. Sun, Y.B., Wang, Q., Yang, S.T., Sheng, G.D., Guo, Z.Q., 2011. Characterization of nano-iron oxyhydroxides and their application in UO₂²⁺ removal from aqueous solutions. *J. Radioanal. Nucl. Chem.* **290**, 643–648.
4. Masoudi, P., Le Coz, M., Cazala, C., Saito, K., 2019. Spatial properties of soil analyses and airborne measurements for reconnaissance of soil contamination by ¹³⁷Cs after Fukushima nuclear accident in 2011. *J. Environ. Radioact.* **202**, 74–84.
5. Zhidkin, A.P., Shamshurina, E.N., Golosov, V.N., Komissarov, M.A., Ivanova, N.N., Ivanov, M.M., 2020. Detailed study of post-Chernobyl Cs-137 redistribution in the soils of a small agricultural catchment (Tula region, Russia). *J. Environ. Radioact.* **223–224**, 106386.
6. M. Kryuchkova, R. Fakhruilin, Kaolin alleviates graphene oxide toxicity, *Environmental Science & Technology Letters* **5**, 295-300 (2018).

Obtaining the hybrid fibrous materials with adsorption properties Tarasenko N.^{1,2}, Koliada M.¹, Plavan V.¹, Budash Yu.¹

¹ Kyiv National University of Technologies and Design

² The National Technical University of Ukraine "Igor Sikorsky Kyiv Polytechnic Institute"
e-mail: tarasenko.nv@ukr.net

Contamination of wastewater with heavy metal ions is an important environmental problem and occurs in many industries. The use of polymeric materials as sorbents of metal ions has become quite widespread due to their high efficiency and lack of secondary contamination [1-3]. Polymer adsorption composites based on fibrous materials have several advantages over other structural forms of adsorbents. They have an extremely high reaction surface area, which can be adjusted in a wide range, changing the type, linear density and shape of the surface of the fibers in the material. All mentioned factors intensify the adsorption process, increases the rate of removal of various contaminants and reduces the cost of water treatment. Fibrous waste from the textile industry can be a quite acceptable raw material for the production of nonwoven fibrous materials with adjustable physical and mechanical properties [4]. By modifying such materials with different types of dispersed mineral fillers, it is possible to create sorption-active fibrous composites.

The purpose of the work is to create hybrid materials by modifying the nonwoven fibrous base with powdered mineral adsorbents to treat wastewater from heavy metal ions.

Non-woven materials obtained from textile industry elastic fibrous waste were used as a basis in the work. They consisted of complex fibers Lycra 162C (linear density 4.4 tex) (PU), and fibers Nylon 6.6 f20/1 (linear density 3.3 tex) (PA-6.6) in a ratio of 70/30 wt. %. As an adsorbent used powders of clays of montmorillonite and palygorskite type in the amount of up to 30% by weight of nonwoven material.

Determined the sequence of separate stages and rational parameters of the process of introduction of powder adsorbents into nonwoven fibrous materials. Determined the type and characteristics of the binder solution, which provides satisfactory fixation of adsorbent particles in the fibrous structure of the nonwoven material. Shown the effectiveness of the use of cationic surfactants in this process. Performed a comparative analysis of the sorption capacity (Cr^{3+}) of the obtained samples of hybrid fibrous materials with different types of adsorbents. The highest efficiency of extraction of Cr^{3+} ions from solutions is demonstrated by samples containing clay adsorbent of palygorskite type when used as a binding aqueous-alcoholic solution (5 wt.%) copolyamide.

Thus, the expediency of using the clay minerals of the palygorskite type as fillers for obtaining the fibrous materials with sorption properties using an aqueous-alcoholic copolyamide solution as a binder has been proved. Further research in this direction may be aimed at optimizing individual stages and the use of other types of adsorbents.

References

- [1] H. Pang, Y. Wu, X. Wang, B. Hu, and X. Wang, "Recent advances in composites of graphene and layered double hydroxides for water remediation: a review," *Chemistry—An Asian Journal*, vol. 14, no. 15, pp. 2542–2552, 2019.
- [2] X. Liu, R. Ma, X. Wang et al., "Graphene oxide-based materials for efficient removal of heavy metal ions from aqueous solution: a review," *Environmental Pollution*, vol. 252, pp. 62–73, 2019.
- [3] X. Wang, L. Chen, L. Wang et al., "Synthesis of novel nanomaterials and their application in efficient removal of radionuclides," *Science China Chemistry*, vol. 62, no. 8, pp. 933–967, 2019.
- [4] Ye. Kucherenko, Yu. Budash, V. Plavan *at all*. Manufacturing and properties of nonwovens based on waste from elastic fibers. Proceedings of The 7th International Conference on Advanced Materials and Systems /edited by Luminița Albu, Viorica Deselnicu. - Bucharest, Romania, October 18 th-20 th, 2018. - pp. 343-348.

**EVALUATION OF ANTIBACTERIAL PROPERTIES AND
PHYTOCHEMICAL COMPOSITION OF *ARTEMISIA DUBIA* WALL. EXTRACTS**
**Rugilė Telinskytė^{1,2}, Agnė Venckutė^{1,2}, Karolina Barčauskaitė¹, Renata
Žvirdauskienė¹, Romas Mažeika¹**

¹ Lithuanian Research Centre for Agriculture and Forestry, Institute of Agriculture, Department of Agrobiological laboratory, Instituto al.1, LT-58344, Akademija, Kedainiai District, Lithuania

² Kaunas University of Technology, Faculty of Chemical Technology, Radvilenu pl. 19, Kaunas, 50254, Lithuania

An excellent alternative to synthetic and chemical plant protection products are biological pesticides of natural origin made from plant extracts and/or essential oils. *Artemisia dubia* Wall. is a perennial herbaceous plant rarely found in Lithuania. The plant is mainly used for energy purposes due to its ability to accumulate large amounts of biomass in a short time [1]. *Artemisia dubia* Wall. belongs to the genus *Artemisia*, which is widely known for its valuable phytochemical properties [2], making it an attractive object for biotechnological research. The aim of this research was to evaluate the effect of different solvents (bidistilled water, methanol, ethanol, Urea, Triton X-100, sodium dodecyl sulfate (SDS)) on the extraction of bioactive compounds from *Artemisia dubia* Wall. plant and to determine antibacterial activity of the extracts. If the hypothesis that *Artemisia dubia* Wall. extracts indicate antibacterial activity would be confirmed, the extracts of this plant could be used to produce biological pesticides in the future. Replacing chemical plant protection products with biological ones is a strategic step in implementing the European Green Course program and reducing the environmental pollution.

Plant material was grown and collected at Lithuanian Research Centre for Agriculture and Forestry in Kedainiai district. Extracts of dried *Artemisia dubia* Wall. were prepared using ultrasound-assisted extraction method. Total polyphenol content (using Folin-Ciocalteu reagent), total flavonoids (using AlCl₃ reagent), total phenolic acids (using Arnou reagent) and radical scavenging activity (using DPPH reagent) were evaluated using spectrophotometric methods. Antibacterial activity was evaluated using agar well diffusion method against 5 different bacteria: *Salmonella typhimurium*, *Escherichia coli*, *Pseudomonas aeruginosa*, *Staphylococcus aureus* and *Bacillus subtilis*.

The largest amount of phenolic content was determined in 2% Triton X-100 extracts – 98.4±9.29 RE mg/g, while the smallest amount was found in 1% Urea extracts – 39.7±2.78 RE mg/g. The largest amount of phenolic acids was determined in 5% Urea and 25% Ethanol extracts, respectively 53.4±3.42 and 55.7±3.39 CAE mg/g, while the smallest amount was obtained in 75% ethanol extract – 20.1±1.60 CAE mg/g. Six extracts indicated similar highest antioxidant activity, ranging from 78.6±7.28 to 86.9±3.01% per 0,5g of plant material, while 10% Urea extracts indicated smallest antioxidant activity – 22.8±1,49% per 0,5g of plant material. The largest amount of flavonoids were obtained in surfactants, ranging from 77.7±1.21 to 128.3±6.69 RE mg/g, while the smallest amount was obtained in bidistilled water and 1% Urea extracts, respectively 29.6±1.51 and 26.6±2.12 RE mg/g. The strongest antibacterial activity was observed in extracts prepared with surfactants, where *Bacillus subtilis* was most susceptible to 2% SDS extracts.

Acknowledgement

This research was carried out under EU structural funds grant No. 09.3.3.-LMT-K-712-24-0188.

References

1. Kryževičienė A., Šarūnaitė L., Stukonis V., Dabkevičius Z., Kadžiulienė Ž. (2010). Daugiamečių kiekčių (*Artemisia vulgaris* L. ir *Artemisia dubia* Wall.) potencialo biokuro gamybai įvertinimas. *Žemės ūkio mokslai*, T. 17. Nr. 1–2. P. 32–40.
2. Giang, P. M., et al. (2015). Phytochemical constituents of *Artemisia dubia* var. *longeraceomsa* forma *tonkinensis*. *Chemistry of Natural Compounds*, Vol. 51, No. 2.

THE REVIEW OF AFFINITY SENSORS FOR THE DIAGNOSIS OF COVID-19

Maryia Drobysh^{1*}, Almira Ramanaviciene², Roman Viter^{3,4}, Arunas Ramanavicius^{1,2}

¹*Department of Functional Materials and Electronics, State Research Institute Center for Physical and Technological Sciences, Vilnius, Lithuania*

²*NanoTechnas–Center of Nanotechnology and Materials Science, Faculty of Chemistry and Geosciences, Vilnius University, Vilnius, Lithuania*

³*Center for Collective Use of Scientific Equipment, Sumy State University, Sumy, Ukraine*

⁴*Institute of Atomic Physics and Spectroscopy, University of Latvia, Riga, Latvia*

*maryia.drobysh@ftmc.lt

Severe acute respiratory syndrome coronavirus 2 (SARS-CoV-2) is a spherical structure inside which is a helically symmetrical nucleocapsid containing positive-sense single-stranded RNA. SARS-CoV-2 genome expresses open reading frames encoding structural proteins, namely, spike (S), envelope (E), nucleocapsid (N), and membrane (M) protein. The entry of the SARS-CoV-2 into the host triggers the sequential chain stimulation of the different immune cells leading to the inducing of the humoral immune responses by expressing antigen-specific antibodies, mostly, immunoglobulins M (IgM) and G (IgG). Commonly, the S- and N-proteins act as antigens for specific binding to antibodies.

Reducing the dissemination rate by the implementation of fast and sensitive detection methods is the main tool against the spreading of SARS-CoV-2 causing the coronavirus disease 2019 (COVID-19). There are three general strategies currently used to detect SARS-CoV-2 and to diagnose COVID-19, namely, molecular tests based on the determination of viral RNA [1], antigen tests based on the determination of viral proteins, and antibody tests based on the determination of specific antibodies against the coronavirus. Besides the conventional approaches, affinity biosensors also showed efficacy in the determination of SARS-CoV-2 infection. Some of the sensors were reviewed in our paper [2].

As an analytical signal source for biosensing, nucleic acid hybridization, antigen-antibody interactions, monitoring surface alterations, and changes of reactive oxygen species (ROS) levels [3] are employed. Among the overviewed antigen-antibody affinity sensors, molecularly imprinted polymers (MIP) based electrochemical sensor with the lowest detection limit (15 fM) was shown as more stable in comparison to protein based sensors [4]. The spectroscopic ellipsometry and surface plasmon resonance (SE/SPR) based technique made it possible to draw important conclusions about the structure of the antigen-antibody complex, as well as to study the kinetics of its formation, which is valuable for the design of new immunosensors [5]. The review revealed that the biosensors with electrochemical based signal registration prevail in biosensing development due to their cheapness, simplicity, and mass production capability.

Acknowledgments: This project has received funding from Research Council of Lithuania (LMTLT) grant No. S-LLT-21-3 and performed in cooperation with the University of Latvia Project No FP-21106- ZF-N-109.

References

1. J. Dronina, U.S. Bubniene, A. Ramanavicius. *Biosens Bioelectron.* **175** (2021) 112867.
2. M. Drobysh, A. Ramanaviciene, R. Viter, A. Ramanavicius. *Micromachines.* **12** (2021).
3. Z.S.Miripour, R. Sarrami-Forooshani, H. Sanati, J. Makarem, M.S. Taheri, F. Shojaeian, A.H. Eskafi, F. Abbasvandi, N. Namdar, H. Ghafari et al. *Biosens Bioelectron.* **165** (2020) 112435.
4. A. Raziq, A. Kidakova, R. Boroznjak, J. Reut, A. Opik, V. Syritski. *Biosens Bioelectron.* **178** (2021) 113029.
5. I. Plikusiene, V. Maciulis, A. Ramanaviciene, Z. Balevicius, E. Buzavaite-Verteliene, E. Ciplys, R. Slibinskas, M. Simanavicius, A. Zvirbliene, A. Ramanavicius. *Colloid Interface Sc.* **594** (2021) 195-203.

FORMATION AND CHARACTERIZATION OF CHLOROPHYLL-A WITHIN TETHERED BILAYER LIPID MEMBRANE

Viktorija Liustrovaitė^{1*}, Aušra Valiūnienė¹, Gintaras Valinčius², Arūnas Ramanavičius^{1,3}

¹ *Department of Physical Chemistry, Faculty of Chemistry and Geosciences, Vilnius University, Vilnius, Lithuania*

² *Institute of Biochemistry Vilnius University, Vilnius, Lithuania*

³ *Laboratory of Nanotechnology, State Research Institute Center for Physical Sciences and Technology, Vilnius, Lithuania.*

* *viktorija.liustrovaite@chgf.stud.vu.lt*

In some recent biophysical and biochemical studies many different simplified biomimetic analogues of lipid membranes were widely used to evaluate/model structural and permeability/transport properties of more complex natural bio-membranes [1]. The tethered bilayer lipid membrane (tBLM) is a complex system that can be used as an experimental platform for fundamental studies of the structure and function of the biomembrane. Long-chain thiol compounds, such as 20-tetradecyloxy-3,6,9,12,15,18,22-heptaohexatricosane-1-thiol (WC14), can be utilized as "anchors" in self-assembled monolayer (SAM) synthesis, allowing the production of stable and repeatable phospholipid bilayers [2]. In this work, one of such models, tBLM on the gold surface is formed by using the fusion of vesicles [3]. This immobilized membrane alteration enables different biosensors to be produced by adding lipid components such as DOPC (1,2-dioleoyl-sn-glycero-3-phosphatidylcholine) and cholesterol [4], having stability that can be modified by adding molecules such as chlorophyll a (Chl-a). By including lipid components such as DOPC and Chol, which give extra stability, specific modifications of tBLMs are ideal for the construction of diverse biosensors.

The investigation is performed by applying electrochemical impedance spectroscopy (EIS) to measure dielectric capacity and conductivity changes. Fluorescence microscopy (FM) is used to estimate the morphology of the membranes. The goal of this research is to see if the photoactive compound Chl-a could be incorporated into a tethered bilayer lipid membrane to create a platform that could be used to develop tBLM photosensitive surface constructs in the future, potentially for the development of new biosensors and biomimetic artificial leaves.

Acknowledgement. This research was funded by a grant (No. S-MIP-20-18) from the Lithuanian Research Council.

References

1. V. Liustrovaite et al. *Journal of the Electrochemical Society* **168(2)**, 066506 (2021)
2. R. Budvytyte et al. *Langmuir* **29**, 8645–8656 (2013)
3. I. Gabriunaite et al. *Journal of Pharmaceutical and Biomedical Analysis* **177**, 112832 (2020)
4. A. Valiuniene et al. *Bioelectrochemistry* **136**, 107617 (2020)

3D PRINTED ELECTRODES FOR APPLICATIONS IN ELECTROCHEMICAL SENSING

Mohamed Abdelkader^{*1,2}, Rasa Pauliukaite¹

¹ *Department of Nanoengineering, Center for Physical Sciences and Technology (FTMC), Savanoriu Ave. 231, LT-02300 Vilnius, Lithuania*

² *Department of Advanced Materials, Institute for Nanomaterials, Advanced Technologies and Innovation (CXI), Technical University of Liberec, Studentská 1402/2, 46117 Liberec, Czech Republic*

** mohamed.fawzy@ftmc.lt*

Applications of electrochemistry vary from sensors to energy storage, from electrolysis to fuel cells. One of the important fields of electroanalysis is biosensing. Biosensors act as a transducer converting a biological response into a detectable electrical signal [1], a biosensor can be used for several applications depending on its type. There are different types of biosensors ranging from enzyme based, tissue based, immunosensors, DNA biosensors, to thermal and piezoelectric ones [2]. The fast and efficient applicability of electrochemical based biosensors can be noticed from the recent COVID-19 crisis as a group of researchers made an electrochemical biosensor based on RNA detection for a rapid detection of the COVID-19 virus [3]. The electrochemical electrodes can be redesigned or functionalized to act as certain biosensors, e.g., the electrochemical measurement system can be embedded within a needle for glucose level measurement which can be an excellent solution for diabetics [4]. Carbon ceramic electrodes modified with single walled carbon nanotubes can be used for detection of codeine and caffeine [5].

3D printing is a crucial factor in additive manufacture as it allows the printing of customized and innovated designs [6]. Conductive filaments and polymers are usually used to print electrodes that can be used in electrochemical analysis and sensing applications. 3D electrodes are not yet widely used, but more and more researchers try to employ them in electrochemistry. Several examples of their fabrication techniques can be found in the literature, for example a group used 3D printed electrodes to monitor the brain activity [7], another group used a metal plated 3D printed electrode for the carbohydrates sensing [8].

The aim of this study is to design, print and characterize customized 3D electrodes that can be further used in sensing application. The study can be extended to make customized filaments using different conductive polymers and nanomaterial allowing to study and define the effect of the selected polymers and nanomaterials on the sensor response and sensitivity.

References

- 1- A. Haleem, M. Javaid , R. P. Singh, R. Suman , S. Rab. *Sensors International*. **2** (2021).
- 2- P. Mehrotra. *Journal of Oral Biology and Craniofacial Research*. **6** (2016) 2.
- 3- A. Yakoh, U. Pimpitak, S. Rengpipat , N. Hirankarn , O. Chailapakul, S. Chaiyo. *Biosensors and Bioelectronics*. **176** (2021).
- 4- X. Zhang, H. Ju, J. Wang. *Electrochemical Sensors, Biosensors and their Biomedical Applications*. Academic Press, (2008).
- 5- B. Habibi, M. Abazari, M. H. P. Azar. *Colloids and Surfaces B: Biointerfaces*. (2014).
- 6- J. Kietzmann, L. Pitt, P. Berthon. *Business Horizons*. **209** (2015) 58.
- 7- S. Krachunov, A. J. Casson. *Sensors*, **16** (2016) 10.
- 8- K. P. Kumar, K. Ghosh, O. Alduhaish, M. Pumera. *Electrochemistry Communications*. **120** (2020).

THE APPLICATION OF SCANNING ELECTROCHEMICAL MICROSCOPY FOR THE EVALUATION OF ALCOHOL BIOSENSOR BASED ON YEAST CELLS

Katazyna Blazevic¹, Timas Merkelis¹, Antanas Zinovicius², Arunas Ramanavicius¹, Inga Morkvenaite-Vilkonciene²

¹ *Department of Physical Chemistry, Faculty of Chemistry and Geoscience, Faculty of Chemistry and Geoscience, Vilnius University, Vilnius, Lithuania*

² *Department of Mechatronics, Robotics, and Digital Manufacturing, Vilnius Gediminas Technical University, Vilnius, Lithuania*

katazyna.blazevic@chgf.stud.vu.lt

Baker's yeast (*Saccharomyces cerevisiae*) is one of the simplest single-cell fungal organisms. *S. cerevisiae* is cheap, widely used in the industry and in the household. Moreover, it is used as a cell model system by researchers because of its similarities to plant and eucaryotic cell catalytic pathways [1]. In order to develop accessible and low-cost tools for monitoring environmental issues a biosensor with living *S. cerevisiae* cells can be used [2]. In the current paper the toxicological effects of alcohols on living yeast cells are investigated by electrochemical methods. Alcohols are used in everyday life as a base in pharmaceutical tinctures and for cleaning products or sanitizers. For this study ethanol and isopropanol as extensively used alcohols were chosen for evaluating the influence to the viability of *S. cerevisiae* cells.

Scanning electrochemical microscopy (SECM) is a device, which measures electrochemical characteristics locally [3]. It was used in this research due to its possibility to work in the microscale and quickly observe steady-state current. SECM consisted of a three-electrode system where the ultramicroelectrode (UME) is connected to a positioner that can move in three axes. The electrochemical signal is measured by scanning the surface of the sample. In previous our research, the toxicity of 9,10-phenanthrenequinone was investigated [4]. It was found that toxic materials can be used for the development of biosensors if they are applied in low concentrations. Good results were obtained by using toxic materials in biofuel cells, especially if they are immobilized on the electrode rather than adding them to the solution. In the current research, the yeast were used for the detection of ethanol and isopropanol in electrochemical cell. It was found that SECM can be used for the detection of ethanol/isopropanol concentrations up to 4 mM.

Acknowledgements. This research was funded by the European Social Fund according to the activity "Development of Competences of Scientists, other Researchers and Students through Practical Research Activities". Project No 09.3.3.-LMT-K-712-25-0156.

References

1. A. Valiūnienė, J. Petronienė, M. Dulkys, A. Ramanavičius Investigation of Active and Inactivated Yeast Cells by Scanning Electrochemical Impedance Microscopy. *Electroanalysis* 2020; p. 367-374.
2. A. Ramanavicius, I. Morkvenaite-Vilkonciene, U. Samukaite-Bubniene, J. Jolanta Petroniene, J. Barkauskas, P. Genys, V. Ratautaite, R. Viter, I. Iatsunskyi, A. Ramanaviciene. Scanning electrochemical microscopy and electrochemical impedance spectroscopy-based characterization of perforated polycarbonate membrane modified by carbon-nanomaterials and glucose oxidase. *Colloids and Surfaces A: Physicochemical and Engineering Aspects* 2021, 624, 126822
3. J. Rozene, I. Morkvenaite-Vilkonciene, I. Bruzaite, A. Dzedzickis, A. Ramanavicius. Yeast-based microbial biofuel cell mediated by 9,10-phenanthrenequinone. *Electrochimica Acta* 2021, 373, 137918.
4. I. Morkvenaite-Vilkonciene, A. Ramanaviciene, A. Ramanavicius, 9,10-Phenanthrenequinone as a Redox Mediator for the Imaging of Yeast Cells by Scanning Electrochemical Microscopy. *Sensors and Actuators B Chemical* 2016, p. 200–206.

METAL OXIDE SURFACES APPLICATION FOR BIOLOGICAL MEMBRANE FORMATION

Inga Gabriūnaite^{1*}, Anastasija Aleksandrovič¹, Aušra Valiūnienė¹

¹ Faculty of Chemistry and Geosciences, Vilnius University, Vilnius, Lithuania

* e-mail address: inga.gabriunaite@chf.vu.lt

Phospholipid bilayer membrane (BLM) models on solid support is a convenient subject for investigating interactions between proteins and biological membranes. Recently, metal oxide surfaces have been applied for phospholipid membrane formation [1,2,3]. These substrates became attractive as solid supports for their commercial availability and low price. Metal oxides could be easily functionalised with self-assembled monolayers (SAMs) by silane chemistry. These SAMs act as anchoring units for immobilisation of the BLMs. Such membranes could be easily characterised with surface sensitive techniques, such as atomic force microscopy, electrochemical impedance spectroscopy, surface plasmon resonance.

In this paper inexpensive and commercially available fluorine doped tin oxide (FTO) was functionalised with either octadecyltrichlorosilane (OTS), or a mix of OTS and methyltrichlorosilane (MTS). Vesicle fusion method was applied for the BLM formation. Membrane consisted of 60 mol% 1,2-dioleoyl-sn-glycero-3-phosphocholine (DOPC) and 40 mol% cholesterol (Chol). Biological relevancy of the membrane was tested using phospholipase A₂, melittin and α -hemolysin.

Overall, presented results confirmed, that phospholipid membrane was formed on FTO surface and it could be applied for the development of biosensors for toxin detection.

References

1. A. Valiuniene, Z. Margarian, I. Gabriunaite, V. Matuleviciute, T. Murauskas, G. Valincius, J. Electrochem. Soc. 163 (2016) H762.
2. I. Gabriunaite, A. Valiuniene, G. Valincius, Electrochim. Acta. 283 (2018) 1351.
3. A. Valiuniene, T. Petrulioniene, I. Baleviciute, L. Mikoliunaite, G. Valincius, Chem. Phys. Lipids. 202 (2017) 62.

APPLICATION OF PRUSSIAN BLUE IN THE DEVELOPMENT OF ENZYMATIC BIOSENSORS

Povilas Virbickas^{1*}, Narvydas Dėnas¹, Aušra Valiūnienė¹, Gabija Kavaliauskaitė¹

¹ Faculty of Chemistry and Geosciences of Vilnius University, Naugarduko str. 24, LT-03225 Vilnius, Lithuania

* povilas.virbickas@chgf.vu.lt

Prussian blue (PB) is an inorganic pigment widely applied in formation of sensors and biosensors. The application of PB in biosensors is based on PB's sensitivity to various parameters of the medium, which are changing during enzymatic reactions, e.g. change in H₂O₂ concentration [1, 2, 3], change in NH₄⁺ ion concentration [4] or pH [3, 5]. The sensitivity of PB to hydrogen peroxide is based on chemical reaction between reduced form of PB, which is called Prussian white (PW), and H₂O₂ (1):

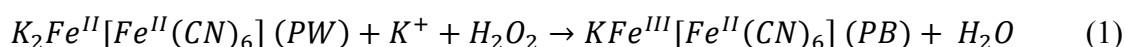

Hydrogen peroxide-caused oxidation of PW can be monitored optically, since PW changes its color from transparent to deep blue when it is oxidized by H₂O₂ [1, 3]. Therefore, optical biosensors which involves PW sensitivity to glucose have been successfully used to detect glucose. Moreover, when potential value around 0 V vs Ag|AgCl|KCl_(sat.) is applied to PB layer, PB exhibits electrocatalytic activity in reduction of hydrogen peroxide [2]. Special attention should be paid to very low potential (0 V vs Ag|AgCl|KCl_(sat.)) at which PB acts as a catalyst in H₂O₂ reduction – at low values of potential interferences of the most electrochemical active species presented in clinical sample is avoided [6], therefore, the usage of PB allows to create electrochemical glucose biosensors which exhibit high reliability.

The sensitivity of PB to NH₄⁺, K⁺, Cs⁺ and Rb⁺ ions is based on unique role of this ions in reduction of PB. When PB is being reduced to PW, these ions (NH₄⁺, K⁺, Cs⁺ and Rb⁺) are intercalating into the crystal lattice of PB to maintain charge neutrality of newly-formed PW [4]. Moreover, concentration of NH₄⁺, K⁺, Cs⁺ and Rb⁺ affects reduction potential of PB, thus, PB can be used as signal transducer for electrochemical or electrochromic biosensors which involve urease [4].

PB exhibits two types of sensitivity to pH: (i) when PB is formed in so-called “insoluble” form, Prussian blue undergoes reversible hydrolysis in alkaline conditions [2], therefore, PB can be used to monitor changes in pH which occurs during enzymatic reactions; (ii) PB also exhibits dependency of charge transfer resistance on pH – when PB is being reduced to PW or PW is being oxidized to PB, hydrogen ions are considered to participate in electron-hopping conduction mechanism through the PB layer [5], therefore, pH of solution affects intensity of charge transport through the layer of PB.

The aim of this work is to analyze the performance of PB as a signal transducer in enzymatic biosensors, to highlight the common problems which occurs during PB-based sensing and to discuss possible ways to improve reliability and overall performance of PB-based biosensors. The applicability of structural analogues of PB (PBsa) in biosensors and comparison between analytical performance of PB and PBsa are also discussed in this work.

References

1. P. Virbickas, et al. J. Electrochem. Soc. **166** (2019) B927-B932.
2. A.A. Karyakin. Electroanal. **13** (2001) 813-819.
3. R. Koncki et al. Analyst **126** (2001) 1080-1085.
4. A. Valiūnienė et al. Electroanal. **32** (2020) 503-509.
5. J.J. Garcia-Jareno et al. Electrochim. Acta **44** (1998) 395-405.
6. A. Valiūnienė et al. J. Electrochem. Soc. **164** (2017) B781-B784.

APPLICATION OF WASTE MATERIAL FOR CATALYTIC DEGRADATION OF METAL COMPLEX DYE

Edita Sodaitienė^{*}, Audronė Gefenienė, Aušra Selskienė,

Romas Ragauskas, Rimantas Ramanaukas

Department of Chemical Engineering and Technology, Center for Physical Sciences and Technology, Vilnius, Lithuania

** edita.zubryte@ftmc.lt*

The amount of dyes used in various industries is increasing, posing a risk to the environment and human health. Organic dyes into wastewater generally get from the coloring and rinsing procedures. Catalytic degradation of the dyes could be as an alternative method for adsorption processes. Various iron-based materials (oxides, hydroxides and oxyhydroxides) are classified as promising heterogeneous Fenton catalysts [1, 2]. Recently, the catalytic activity of iron-rich wastes of various composition generated during industrial processes were tested for activating hydrogen peroxide. The purpose of this study was to evaluate the efficiency of groundwater treatment waste (GWTW) in catalytic oxidative degradation of organic pollutant the chromium complex azodye used for anodized aluminum coloring. The sunlight as a cheap and sustainable source of energy was explored. The catalyst was characterized using SEM (Fig. 1a), XPS, FTIR and X-ray fluorescence spectroscopy. The main components of GWTW are ferrihydrite ($\text{Fe}(\text{OH})_3$), goethite ($\alpha\text{-FeOOH}$) and hematite ($\alpha\text{-Fe}_2\text{O}_3$) that can activate the decomposition of peroxide leading to radical formation. The activity of GWTW catalyst in oxidative degradation of metal complex dye has been investigated depending on the solution pH, catalyst loading (Fig. 1b), reaction time and temperature. The dye anions (RSO_3^-) are electrostatically attracted by the positive catalyst surface, where the dye degradation process in the presence of H_2O_2 occurs. The rate of the dye degradation increased with increase in catalyst dose from 0.5 to 1.0 g/L. The rise in temperature from 20 to 60 °C and solution acidity from pH 5 to pH 3 positively influenced the dye removal process. The obtained results show that the nanostructured GWTW produced as a result of the deironing of groundwater by cascade aeration is an effective catalyst in the Fenton-like oxidation of metal complex dye in the presence H_2O_2 leading to discoloration of wastewater.

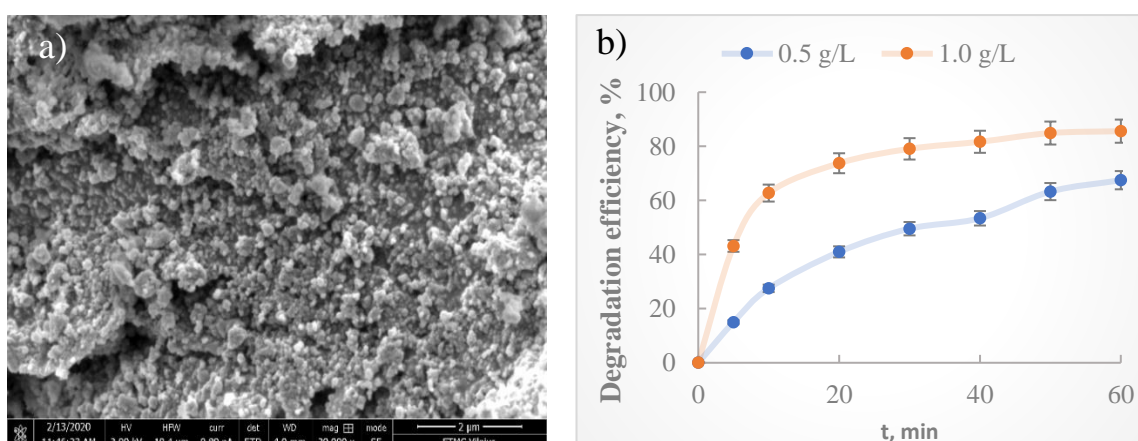

Fig. 1. SEM image of the surface morphology of the GWTW catalyst dried at room temperature (a); impact of GWTW catalyst loading and reaction time on the dye degradation efficiency (b).

References

1. N. Thomas, D.D. Dionysiou, S.C. Pillai. *J. Hazard. Mater.* **404** (2021) 124082.
2. E.G. Garrido-Ramírez, B.K.G. Theng, M.L. Mora. *Appl. Clay Sci.* **47** (2010) 182–192.

ENZYMATIC TREATMENT INFLUENCE ON DERMATAN SULPHATE CHANGES IN HIDE

Virgilijus Valeika*

Department of Polymer Chemistry and Technology, Kaunas University of Technology, Kaunas, Lithuania
** virgilijus.valeika@ktu.lt*

There are two main "cementing" materials in a derma tissue of skin/hide. One of them is the hyaluronic acid which considerable amount is removing during the process of soaking. The second is acidic dermatan sulphate. The highly charged dermatan sulphate glycosaminoglycan side chains are split from the proteoglycan backbone by the strong alkali. The amount of dermatan sulphate depends on the hide or skin type, section and layer [1].

The development of enzymatic unhairing process has raised the question, what the influence have the enzymes on dermatan sulphate in the treated hide?

To get the answer, an action of sodium sulphide separately and of sodium sulphide combined with proteolytic enzyme (enzyme preparation *NUE O.6 MPX*) on a kinetic of change of both collagen proteins and dermatan sulphate changes was explored.

The use of unhairing solution containing 7 g/l Na₂S and 0.3 *NUE O.6 MPX* during the treatment led to lowering of dermatan sulphate content in the hide (Table).

Table 1. Influence of treatment duration by solution of Na₂S+*NUE O.6 MPX* on dermatan sulphate content in the treated hide

Treatment duration	Amount of dermatan sulphate in hide, %	Removal of dermatan sulphate, %
Hide after soaking (0 hours)	0.51	-
Treatment 6 hours	0.36	29
Treatment 10 hours	0.33	35
Treatment 24 hours	0.28	45

The treatment with application of enzyme removes dermatan sulphate from hide. The most intense process goes during first 6 hours, later the process slows down. Accordingly, the enzymes plays active role in the dermatan sulphate removal and, parallel, influences on the properties of unhairing hide. The investigation is continued.

References

1. J. Alexander, J. Amer. Leather Chem. Ass., **83** (1988), 287.

STARCH ACETATE SORBENTS FOR REMOVAL OF PARABENS FROM AQUEOUS MEDIUM

Karolina Aleknaite^{*}, Deimante Rosliuk, Ramune Rutkaite

Department of Polymer Chemistry and Technology, Kaunas University of Technology, Kaunas, Lithuania

** karolina.aleknaite@ktu.edu*

Current lifestyle has led to the extensive usage of cosmetic and personal care products (CPCPs) all over the world. The occurrence of CPCP residues in domestic sewage, municipal wastewater and wastewater treatment systems is inevitable. The monitoring results showed their ambient accumulation exhibiting an increasing trend during the recent years. Parabens can be used in various CPCPs as preservatives, also they are quite easy to be used at industrial scale. However, parabens are great danger to ecosystem due to their potential toxicity, estrogen-mimicking and carcinogenic properties [1]. These complications create a need for search for new ways to additionally eliminate those contaminants.

In this study the synthesized microgranular starch acetates (SA) have been tested as a potential sorbents for removal of alkyl parabens from aqueous medium.

The adsorption of alkyl parabens, namely methylparaben (MP), ethylparaben (EP) and propylparaben (PP), on SA microgranules in water has been investigated by employing the equilibrium adsorption method. It was found that adsorption of parabens on SA proceeded rapidly during the first 10 min (see Fig. 1A). The obtained isotherms of methyl-, ethyl- and propylparabens adsorption on SA at 20 °C are presented in Fig. 1B.

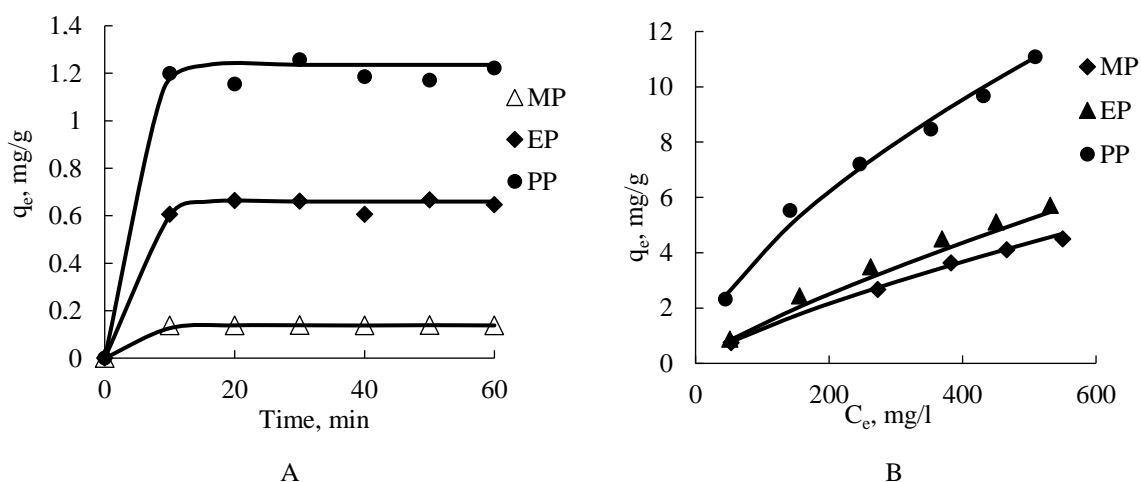

Fig. 1. Adsorption kinetics (A) and isotherms (B) of alkyl parabens on SA at 20 °C. Symbols represent experimental data and the lines represent fitted curves of the Langmuir adsorption model in (B)

The Langmuir, Freundlich and Dubinin–Radushkevich adsorption models were used to describe the adsorption isotherms and the main parameters of adsorption models such as the Langmuir sorption capacity (Q_L), the Freundlich constant (n_F) and the Dubinin-Radushkevich adsorption energy (E_{DR}) values were calculated and revealed that adsorption occurred due to physical forces. The Langmuir sorption capacity Q_L was increasing by increasing the length of alkyl chain in paraben molecule, in the following order: propylparaben > ethylparaben > methylparaben. To summarize, SA granules can be promising adsorbent for the removal of parabens from aqueous medium.

References

1. C. Haman et al., Occurrence, fate and behavior of parabens in aquatic environments: A review: Water Research 68, 1-11 (2015)

CATIONIC STARCH FLOCCULANTS FOR MICROALGAE BIOMASS SEPARATION

Karolina Almonaityte^{*}, Joana Bendoraitiene, Diana Masiulionyte, Ramune Rutkaite

Department of Polymer Chemistry and Technology, Kaunas University of Technology, Lithuania

** karolina.almonaityte@ktu.lt*

In the context of the overuse of fossil fuels, such as coal and oil, world is now facing environmental, energy and health challenges. Some studies have indicated that microalgae are a promising feedstock of biofuel for alternating fossil fuels. Since microalgae are small in size, of approximately 2–12 μm , and possesses a negatively charged surface, the algal cells are suspended in medium as colloidal particles. Microalgae harvesting is difficult, time consuming, and costly. Among the traditional microalgae harvesting methods are flotation, filtration, centrifugation and flocculation. Flocculation is a comparatively low-cost method that can be applied at large scale. The synthetic flocculants are derived from petroleum products. Therefore, the starch-based flocculants could be a suitable alternative to replace synthetic ones [1]. The aim of this investigation was to obtain cationic starches (CS) and to evaluate their thermal, biodegradation and flocculation properties.

Cationic starches of different degree of substitution were obtained by etherification of native potato starch with 3-chloro-2-hydroxypropyl trimethylammonium chloride by using NaOH and CaO additives. The CS biodegradation tests in a compost were carried out according to ISO 14855-2 standard. The thermal properties of CS and microalgae were also evaluated. The flocculation properties were assessed by evaluating filtration efficiency of microalgae dispersions using a standard capillary suction time apparatus. It was determined that microalgae flocs would be readily and rapidly dewatered after the destabilization process involving CS flocculant (see Fig. 1). Hence, CS can be considered as an effective biodegradable modified starch flocculant suitable for thickening and dewatering of microalgae.

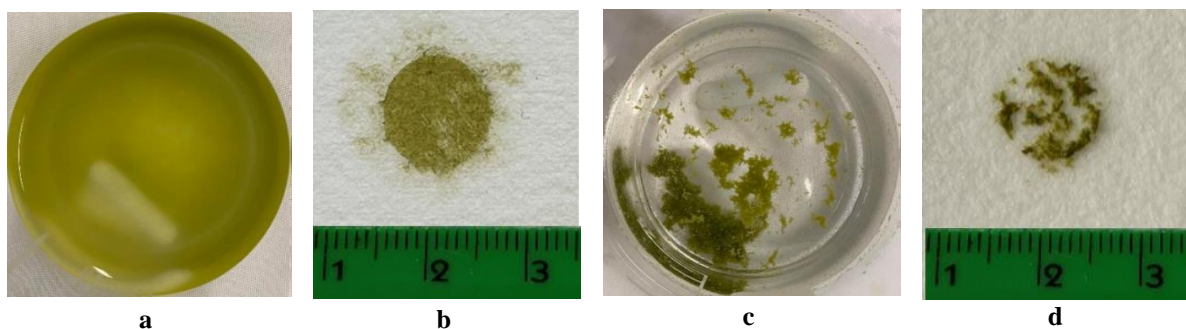

Fig. 1. The photographs of microalgae dispersion (a), dewatered microalgae (b), microalgae dispersion after flocculation with CS_{0.28} (c), dewatered microalgae after flocculation (d). Microalgae concentration was 0.7 g/l

The use of derivatives of natural starch e.g. cationic starches has the advantages of both low price and biodegradability, moreover, their decomposition products are environmentally friendly, and they can be produced from renewable sources.

References

1. A. Mohseni, L. Fan, F. Roddick, H. Li, Y. Gao, Z. Liu. *J. Appl. Phycol.* **33** (2021) 917–928.

COMPOUND FERTILIZERS GRANULATION USING BUCKWHEAT HUSK ASH

Odeta Brigaitytė^{*}, Rasa Šlinkšienė, Evaldas Griškaitis

*Department of Physical and Inorganic Chemistry of Kaunas University of Technology,
Radvilėnų st. 19, LT- 50254, Kaunas, Lithuania
odeta.brigaityte@ktu.lt*

Renewable energy sources are important in reducing dependence on fossil fuels in developing the EU's green course. Therefore, alternative energy sources such as straw, husks and other combustible bio-waste are being sought. Every year in Lithuania, about 130–140 thousand tons of straw suitable for biofuel production are used. The reuse of biomass ash in agriculture is important to create nutrient cycles, thus there exists great potential in the use of biomass as a fertilizers [1, 2].

In order for biomass ash to be used as a fertilizer in large quantities and become a commodity, it must meet certain requirements of both producers and consumers. Fertilizers composition must meets to the needs of plants; active substances must be in a form accessible to plants; fertilizer must be effectives and do not pose a threat to human safety and the environment [3].

Considering that the ecological buckwheat (JSC "Ekofrisa") husk ash contains 35–39 % soluble potassium (calculated as K_2O) and about 6 % phosphorus soluble in mineral acids (calculated as P_2O_5), but no nitrogen, were added materials which consists nitrogen and phosphorus (ammonium sulphate and ammonium hydrogen phosphate). After granulation of compound fertilizers (Fig. 1) using different (20–60 %) retour content and different (20–24 %) moisture content, the largest part of the marketable fraction (2–5 mm granules) was up to 57 %.

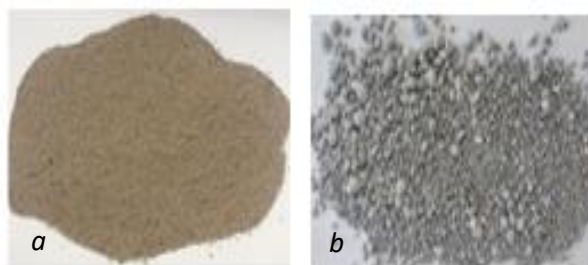

Fig. 1. Buckwheat husk ash: *a* – ash powders; *b* – fertilizers granules

The most important properties of granular fertilizers, as values of granular static strength, bulk density, moisture, and 10 % concentration solution of fertilizer were analysed.

References

1. K. Schiemenz, J. Kern, H. M. Paulsen, S. Bachmann, B. Eichler-Lobermann. Phosphorus Fertilizing Effects of Biomass Ashes. Hardcover, 2011; p. 164.
2. M. Kulokas, M. Praspaliauskas, N. Pedišius. Investigation of Buckwheat Hulls as Additives in the Production of Solid Biomass Fuel from Straw. Lithuania. Energies 2021, 14(2), 265; <https://doi.org/10.3390/en14020265>.
3. Volodymyr Kramar, Possible Utilization Directions Of Ash From Biomass Combustion. Biomass Ash As Fertilizer In Agriculture. UABIO Position Paper № 27. 2020, p. 71. https://uabio.org/wp-content/uploads/2020/12/AZ_Kramar_Zastosuvannya-zoly-biomasy-yak-dobryva_fin_en2.pdf.

THE INFLUENCE OF CELLULOSE ON GRANULAR PRODUCT PROPERTIES

Kristina Jančaitienė*, Rasa Šlinkšienė

Department of Physical and Inorganic Chemistry, Kaunas University of Technology

Radvilėnų rd. 19, LT-50254 Kaunas, Lithuania

E-mail address: kristina.jancaitiene@ktu.lt

Cellulose microfibrils are insoluble cable-like structures that are typically composed of approximately 36 hydrogen-bonded chains containing 500 to 14,000 β -1,4-linked glucose molecules. Cellulose microfibrils comprise the core component of the cell walls that surround each cell. Roughly one-third of the total mass of many plants is cellulose. The long, inelastic, microfibrils wrap around cells in spatially oriented overlapping layers that provide resistance to osmotic pressures that are similar in magnitude to the air pressure in a car tire. The pressure of the plasma membrane against the cell wall rigidifies the cell walls, providing the turgor that allows plants to adopt an erect growth habit [1, 2].

In order to determine the optimal parameters of the granular product (the composition of the raw material, the particle size distribution, the granules strength, the moisture content) using microcrystalline cellulose, various mixtures of raw materials were granulated in laboratory conditions. Crystalline potassium dihydrogen phosphate was granulated by using a drum granulator. Potassium phosphate granulation was performed by using only different amount of water (Fig. 1), and other way - by adding water and binder i.e. cellulose (Fig. 2). Microcrystalline cellulose (commonly used in pharmaceutical applications) was used for granulation. Pellet properties were investigated by standard methods, and surface uniformity assessment was made by scanning electron microscopy techniques.

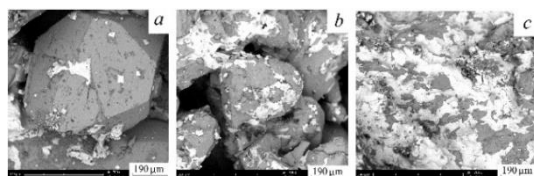

Fig. 1. SEM photos of a product, granulated only with water (no microcrystalline cellulose) with different magnifications:
a – $\times 500$; *b* – $\times 700$; *c* – $\times 2000$

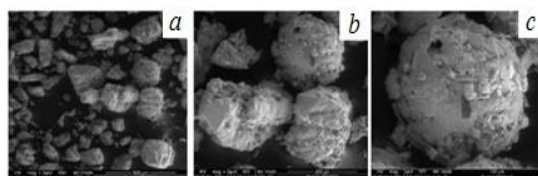

Fig. 2. SEM photos of product granulated with cellulose and water with different magnifications:
a – $\times 200$; *b* – $\times 500$; *c* – $\times 1000$

Figure 2, it is evident that when pharmaceutical grade cellulose was used for granulation, more spherical-shaped pellets were formed in comparison to the pellets formed when granulating with water only.

References

1. D.J. Cosgrove. *Nat. Rev. Mol. Cell Biol.* **850** (2005) 61.
2. F. Marga, M. Grandbois, D. J. Cosgrove, T. I. Baskin. *Plant J.* **181** (2005) 90.

TECHNOLOGICAL SOLUTIONS FOR CO₂ REDUCTION IN BIOGAS

Rokas Klenauskis^{1*}

¹ Faculty of Chemical Technology, Kaunas University of Technology, Kaunas, Lithuania
* rokasklen@gmail.com

Biogas is a rapidly growing alternative to natural gas. This gas mixture is produced during anaerobic digestion of organic materials, this makes biogas production an attractive choice in lowering the accumulation of organic waste in landfills. The composition of biogas depends on digestion process specifics and chosen raw materials. Even in ideal circumstances, methane – the active component, is not the only material present in the mixture. Other gases, such as CO₂, O₂, H₂S and others, either decrease the calorific value of biogas or cause corrosive damage to instruments used in biogas exploitation. The objective of this paper was to design a theoretical technological schematic, to remove CO₂ from biogas and by doing that, turning the mixture into the highly calorific biomethane. Biogas production stream from “Kauno Nuotekų Valykla” (eng. -Kaunas sewage treatment plant), made during anaerobic digestion of wastewater sludge, a process which was analyzed during professional practice, was chosen as the raw material scheme for the schematic. This stream is equal to 7119,2 kg/h of biogas. The goal for the technological schematic was to get a gas stream of 97% (molar) methane concentration, by removing a large portion of CO₂ from the raw material stream. Chemical absorption by MDEA was chosen as the biogas cleaning method. The schematic can be divided into 3 distinct sections: CO₂ absorption, MDEA regeneration, preparation of the MDEA mixture for a new absorption cycle. The separated CO₂ was used as a raw material for unrelated processes, MDEA was fully regenerated and reused. The designed technological schematic can produce 4781,31 kg/h of biomethane, which, if used as fuel for electricity, can produce up to 69057 kWh of electricity. Operating the system requires 5500 kWh of electricity, or ~8% of the potential product energy output. Aspen HYSYS was chosen as the designing application.

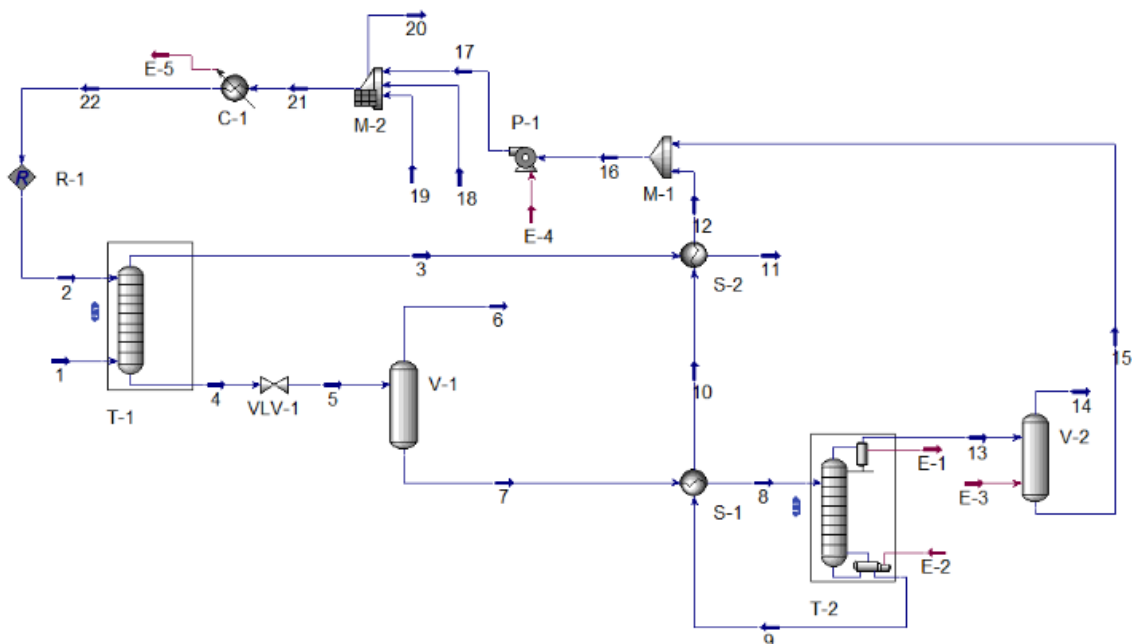

Fig. 1. Full technological schematic for CO₂ chemical absorption via an MDEA solution

ENCAPSULATION OF EUGENOL AND THYME ESSENTIAL OIL IN STARCH SODIUM OCTENYLSUCCINATE

Vesta Navikaite-Snipaitiene^{1*}, Meda Dauksaite¹

¹ Department of Polymer Chemistry and Technology, Kaunas University of Technology, Kaunas, Lithuania

* vesta.navikaite@ktu.lt

Essential oils are derived from plants and are denoted by antibacterial, antioxidant, anti-cancer and anti-inflammatory properties. However, they are chemically unstable and sensitive to degradation. Encapsulation is an effective tool to prepare oil-based high-quality and beneficial products in various industries in order to enhance their chemical, oxidative, and thermal stability [1].

The aim of this study is the preservation of the active properties of essential oils by encapsulation them in starch sodium octenylsuccinate (OSA). Several encapsulation techniques were chosen for eugenol (EU) and thyme essential oil (TH) encapsulation: emulsions containing OSA and EU or TH were prepared; nano spray drying of emulsions was performed. Firstly, six emulsions containing 20% of OSA and 2%, 2.5%, 10% of EU or TH were obtained by using high-shear homogenisator. Afterwards, EU or TH were encapsulated in OSA by using nano spray dryer. The obtained OSA-EU and OSA-TH capsules were characterized by scanning electron microscopy (SEM), Fourier transform infrared spectroscopy and thermogravimetric analysis (TA). According to SEM and TA, the diameter of obtained capsules was 0.5 to 1 μm and the thermal stability of capsules containing eugenol was higher, respectively. The release studies of EU and TH from capsules into ethanol were performed (Fig. 1, A) and the antioxidant activity of capsules was determined (Fig. 2, B).

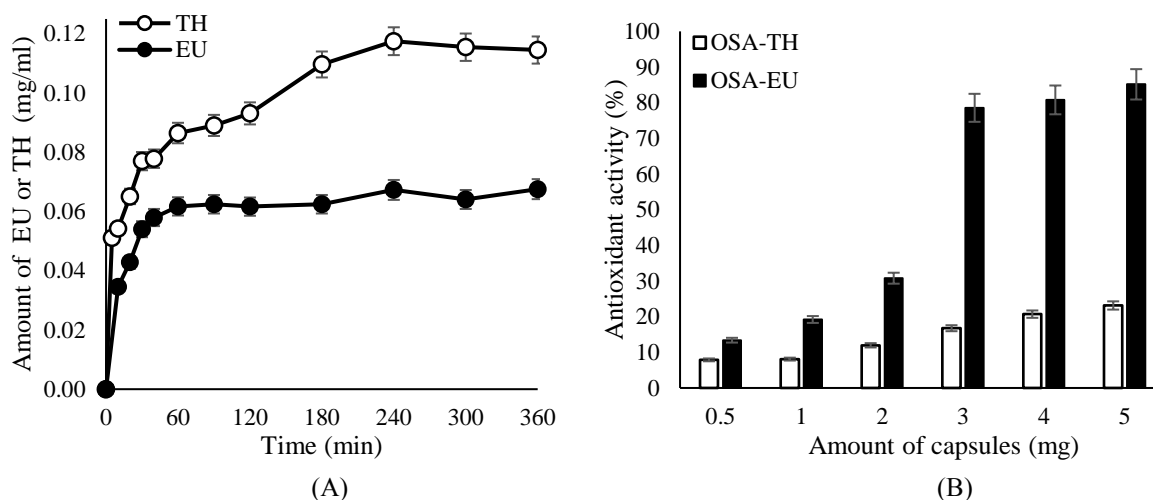

Fig. 1. The released amount of EU and TH depending on time (A) and the antioxidant activity of OSA-EU and OSA-TH capsules (B)

It has been found that encapsulated EU and TH maintain its antioxidant activity and active compounds could be released into ethanol. The study showed that 70 % of EU and 96 % of TH amount were released into ethanol medium over 360 minutes. The antioxidant activity of capsules containing EU was significantly higher than TH. Depending on active compounds concentration in capsules, the antioxidant activity of OSA-EU and OSA-TH was varied from 13 to 85 % and from 8 to 23 %, respectively.

References

1. A. M. Bakry, et al. *Compr. Rev. Food Sci. F.* **15** (2016) 143.

PREPARATION AND PROPERTIES OF COATINGS FOR FERTILIZERS SOLUBILITY CONTROL

Rasa Paleckienė^{*}, Justinas Rabikauskas

*Department of Physical and Inorganic Chemistry, Kaunas University of Technology
Radvilenu str. 19 Kaunas LT - 50254, Lithuania*

** e-mail address rasa.paleckiene@ktu.lt*

One of the most popular and most common ways to control the solubility of the fertilizer is the production of coated/encapsulated fertilizers [1]. This method allows to reduce the solubility of fertilizers and increases absorption time of nutrient. The coating can be performed using various materials, but the most widely applicable and known coated fertilizers are obtained by coating with sulfur, with polymers or with layers of sulfur and polymer [2]. The rate and the mechanism of nutrient release from coated granules process depend on the nature of the coating, its thickness as well as capillary diffusion of the solvent and the solution. The most efficient technique is coating of granules with synthetic polymers, but such films usually do not decompose in the soil and causes serious environmental pollution problems because macromolecular fragments of synthetic polymer remain in the soil. Good and possible way is to produce controlled-release fertilizers (CRF) using biodegradable materials, either natural materials or biosynthetic materials from renewable raw materials [3].

The aim of is work is to explore the possibilities of application of native wheat starch coating in the production of slow-release fertilizers. Starch is a natural polymer available in large amounts from several renewable plant sources, and it is the cheapest biopolymer and it is entirely biodegradable. Unfortunately, using starch in its native form as effective coating material is often limited due to its poor solubility, low mechanical properties and instability at high temperature and pH. Poly (vinyl alcohol) (PVA) is a water soluble, semi-crystalline, fully biodegradable and non-toxic polymer, extensively used in paper coating, textile sizing, drug release and flexible water-soluble packaging films [4].

In this work we were preparing the different formulations composite films by a solution-casting method. Materials used for the preparation of composites: native wheat starch (AB „Roquette Amilina”), poly (vinyl alcohol) (TCI, $(\text{CH}_2\text{CH})_n$, $n = \text{approx. } 1700$), molasses (UAB “Lietuvos cukrus”) and glycerol (GLY) of analytical grade as plasticizer.

The properties of different formulations obtained by modifying bending ratio of starch, glycerol and PVA were also investigated. The degree of swelling and stability in different pH value and different salt solutions were evaluated [5]. Stability of the composite films was verified by instrumental (IR, STA, XRD) methods. Studies of the biodegradability of composite films were performed in different soils at different moisture contents. PVA films modified with wheat starch and molasses have been found to be stable to fertilizers but much more biodegradable.

A biodegradable starch / polyvinyl alcohol (PVA) blend film obtained in this study is suitable for coating the soluble granular fertilizer has been prepared.

References

1. Trenkel, M. E. Slow- and Controlled – release and stabilized Fertilizers, IFA, Paris, 2010.
2. Azeem, B., KuShaari, K. at al. *Polymers*. **12** (2020) 400.
3. Lubkowski, K., Smorowska, at al. *Polish Journal of Chemical Technology* **21** (2019) pp. 52-58.
4. Sofyane, A., Ablouh, E. at al. *Materials Today: Proceedings*, **36**, 1(2021), pp. 74-81.
5. Review of Analytical Methods for Slow- and Controlled- Release Fertilizers, IFA, Paris, 2014.

THE INFLUENCE OF MAYENITE ADDITIVE ON THE EARLY STAGE HYDRATION OF PORTLAND CEMENT

Kristina Ruginyte^{1*}, Anatolijus Eisinias¹

¹ *Department of Silicate Technology, Kaunas University of Technology, Radvilenu 19, LT-50270 Kaunas, kristina.ruginyte@ktu.edu*

Mayenite ($C_{12}A_7$), one of calcium aluminate minerals with $C/A=1.7$, has stimulated the research interest because of its better accelerator effect-rapid hardening activity [1], oxygen mobility, ionic conductivity and catalytic properties in comparison with the other calcium aluminates [2,3]. $C_{12}A_7$ can be employed as a functional component for OPC to regulate the consumption rate of sulphates, and the amount and type of carbonate phases in hydrated products can be modified. The influence of $C_{12}A_7$ on the compressive strength of mortars mainly relates to its hydration behavior, properties of hydrated products and interactions of hydrated products between $C_{12}A_7$ and primary OPC minerals [4]. For this reason, the main objective of the present work is to determine the influence of mayenite additive on the early stage hydration of Portland cement.

Mayenite synthesis was carried out in two stages: hydrothermal synthesis (4 h, 130 °C) and calcined (1 h, at 350 °C (CA1), 550 °C (CA2) and 900 °C (CA3)) [5]. Samples of OPC were prepared in a laboratory grinding mill by grinding cement clinker (JSC “Akmenes cementas”, Lithuania) with a 4.5 % additive of gypsum (“Sigma-Aldrich”, Germany) up to $S_a = 450 \text{ m}^2/\text{kg}$. As these reactions are exothermic, isothermal calorimetry is among the most accurate methods to monitor the global reaction process through the rate of heat production. The synthetic products were added as a partial replacement of OPC at level of 7,5 % by weight of the total cementitious material. Therefore, the water and cement ratio of all OPC samples was equal to 0.5. The microcalorimetric data showed, synthetic calcined additives accelerated the initial reaction (1-3 min) of cement samples because an increase in the maximum heat evolution rate was observed from 0.005 W/g (pure OPC) to 0.1 W/g (OPC with additives). It was determined that, during the initial hydration reaction in the samples with additives, an intensive interaction between mayenite and gypsum proceeded, which led to the formation of ettringite and amorphous aluminium hydroxide. It was examined that after 21-60 min of hydration of samples with additives, CASH or/and monosulphate or/and CAH were crystallized into the products and the hydration mechanism of cement samples was changed. The products were characterized using X-ray powder diffraction, simultaneous thermal analysis.

References

1. J.P. Won et al. *Cem. Concr. Res.* **79** (2015)121.
2. R. Cuccinielo et al. *Atmos Environ.* **79** (2013)666.
3. A. Proto et al. *Catal Commun.* **68** (2015)41.
4. Z. He, Y. Li. *Materials.* **11** (2018)1958.
5. A. Eisinias et al. *Ceram. Int.* **44**(2020)429.

PHOSPHATE FEED SUPPLEMENTS PRODUCED FROM LITHUANIAN DOLOMITE

Rasa Šlinkšienė^{*}, Rokas Velišauskas

Kaunas University of Technology, Radvilenu st.19, LT-50254 Kaunas, Lithuania

** e-mail address of speaker rasantli@ktu.lt*

As the human population grows, so does the need of the commercial animal production grows also, and inorganic phosphate supplements play an important role in the animal feed industry. Calcium phosphates, the most widely used phosphate supplements, supply essential minerals for the development. In the animals bones are stored 99 % of total calcium and 80 % of total phosphorus. The skeletal stores of calcium and phosphorus are used to meet dietary inadequacies. Magnesium is a building material for bones and teeth, and is a significant part of various enzymes and plays an important part in metabolism. Along with calcium, magnesium ensures normal functioning of the nervous and muscular systems (muscles contains more magnesium than calcium). Long-term deficiencies of P, Ca and Mg can cause bones to weaken and even break, and muscles can to weaken and atrophy. The optimum ratio of calcium, magnesium and phosphorus in supplements is Ca:Mg = 1:0.5; Ca:P = 1:1.5 [1–4]. Powder phosphates are not suitable for use because they are dusty, hygroscopic and by long store, they lost powdery. Therefore, the aim of this work was to select the proper method of granulation of feed phosphates. The calcium and magnesium phosphates produced of calcined dolomite by decomposition by phosphoric acid were granulated using a drum and a fluid bed granulator (Fig.1).

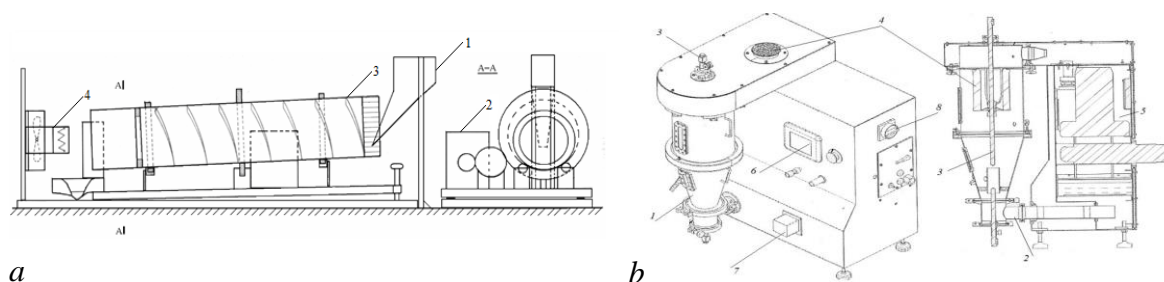

Fig. 1. Granulation equipment: *a* – drum granulator; *b* – fluid bed granulator

Was determined that by using a fluid bed granulator were produced smaller, weaker and more dry granules then by using a drum granulator. The granulometric composition of the product depends on the chosen granulation method and on the moisture content of the initial granulation material. When calcium phosphate were granulating by using drum granulator, the optimum moisture content in the raw material mixture is about 20–26% in order to obtain the highest quantity (about 77–85%) marketable fraction (1–3 mm). The optimum moisture content of raw materials is 15.5 % in order to obtain the highest quantity (about 65–73%) marketable fraction (1–3 mm) in the raw material mixture by using fluid bed granulator. However, both granulators can be use, depending on the parameters of the granular product desired.

References

1. Animal Feeds: Phosphate Supplements. Chemical Economics Handbook. 2019.
2. A. Cooke. Comprehensive Reviews in Food Science and Food Safety. Dietary Food-Additive Phosphate and Human Health Outcomes 2017. DOI 10.1111/1541-4337.12275
3. L. Stewart. Mineral Supplements for Beef Cattle, UGA Cooperative Extension Bulletin 895. 2017.
4. A. L. Lindsay Bazydlo, M. Needham, S. Neil Harris. Calcium, Magnesium, and Phosphate, Laboratory Medicine, **45(1)** (2014) 44–50.

WASTE – FREE PRODUCTION OF GAS SILICATE BLOCKS

Zenonas Valančius, Virginija Valančienė

*Department of Silicate Technology, Kaunas University of Technology,
Radvilėnų 19, LT – 50270, Kaunas, Lithuania;
zenonas.valancius@ktu.lt;*

Autoclaved aerated concrete (AAC) masonry products are very popular in the construction market and are currently widely used. However, the production of such masonry products inevitably generates two types of waste: “off cut” of non-autoclaved aerated concrete (ACW) which are formed by trimming the mass from the molds before hydrothermal treatment and autoclaved aerated concrete, which remain on the mold base after autoclaving (AACW) [1–3]. It is known that about 3–5% of the latter waste is generated and recovery of it is not fully resolved [1, 3]. Therefore the aim of the study was to investigate the possibility of using AACW as an admixture in the production of new AAC – gas silicate blocks.

The following composition of the mixture (AC0) was chosen: cement – 17.5, lime – 12.5, gypsum – 2.5, sand slurry – 50.0, ACW slurry – 20, aluminum paste – 0.11. The water/solids ratio was equal to 0.8. The sand in the forming mixture was replaced by 6.25 % (AC1), 12.5 % (AC2) and 18.75 % (AC3) of AACW during research. All required amount of raw materials was weighed at the beginning of mixing. First, required quantities of sand and ACW slurries were mixed with water together. Second, Portland cement, lime, gypsum and AACW were added. Finally, aluminum paste suspension was placed. The samples were hardened in a laboratory autoclave with a saturated water vapor temperature of 190 °C and an isothermal holding time of 11 h.

The dependency of mechanical properties, porosity, pore size distribution, and mineralogical composition of the AAC samples on composition of forming mass were determinate. Samples were analyzed by XRD, STA, optical microscopy and SEM analysis. The obtained research results are presented in the Table 1.

Table 1. Mechanical properties of AAC samples

	Blowing height, %	Density, kg/m³	Compressive strength, MPa
AC0	28	540	2.20
AC1	28	546	2.25
AC2	29	535	2.50
AC3	30	530	1.80

According to obtained results, samples in which 12.5 % of the sand is replaced by AACW have the highest mechanical strength and sufficient density. Changes in mineralogical composition (increasing amount of tobermorite), among other factors, affect the increase in the compressive strength of the samples. AACW can be used successfully in the production of new AAC because the technological process does not change, and the values of compression strength and other properties are close or even better than the values of the samples without additives.

References

1. W. Arayapranee, G. L. Rempel. *Polym. Comp.* **36** (2015) 2030–2041.
2. A. Fabien, N. Sebaibi & Mohamed Boutouil. *Eur. J. Environ. Civ. Eng.* (2019) 1–18.
3. N. N. Lam. *Int. J. GEOMATE.* **78** (2021) 128–134.

PRODUCTION OF WHITE TEXTURED PAINTS USING SILICATE WASTE

Zenonas Valančius

*Department of Silicate Technology, Kaunas University of Technology,
Radvilėnų 19, LT – 50270, Kaunas, Lithuania;*

zenonas.valancius@ktu.lt

The paint is widely used for coloring various objects or for pigmented coating of the surface for a decorative or protective effect. There are many types of paint, the use of which is decided according to the purpose and use of the object. Titanium oxide is used as a bleaching agent in the production of white silicate water-based paints, which has the highest value in the total cost of the paint. The aim is therefore to look for a way in which at least part of it can be replaced by cheaper components or even production waste.

One such waste could be the phosphogypsum formed by AB „Lifosa“, calcium sulphate, which is visually very white. The aim of this work is to produce white, textured, water-based paints using silicate waste - phosphogypsum, which would correspond in quality to industrial paints. Preliminary studies have shown that phosphogypsum is only suitable as a dye filler. The study produced high-quality paints that complied with paint regulations.

In the work we used analogous raw materials used by one of the silicate paint manufacturers in Lithuania UAB “Maestro team”.

Table 1. Chemical composition of paints produced

Materials	H ₂ O	Bermocoll Prime 1000	20 % KOH	Oratan 4045	Faomaster 8034	Phosphogypsum with 5% CaO	TiO ₂	Ground marble	Dolomite	Acrylic resin dispersion	Crysol TT935
Composition, %	24	0,4	0,2	0,2	0,1	0...50	3...5	1...5	1...25	20	0,1

Studies on the effect of phosphogypsum content on paint properties have shown that it can be added to the mass up to 30 %. However, the addition of phosphogypsum significantly acidifies the mass, causing the paint to lose its performance relatively quickly. Continuing the work, it was found that using a small amount of CaO in the paint mixture can produce paints that match the properties of industrial paints in terms of physical and mechanical properties: such paints have a higher whiteness, better wet cleaning resistance, the same coverage as industrial paints.

We can draw the following conclusions:

1. The use of phosphogypsum as a filler can reduce the amount of TiO₂ in paints and produce whiter paints than existing industrial paints. Its permissible amount is up to 30 %.
2. The use of an additional preservative CaO can extend the life of the paint and improve other physical properties. It should be added 5 % of the phosphogypsum content.

References

1. Rimtautas KAVALIŪNAS, Juozas Vidas GRAŽULIAVIČIUS, Rūta LAZAUSKAITĖ. Lakų ir dažų chemija bei technologija. Mokomoji knyga. Vilniaus pedagoginis universitetas, Vilnius 2008. ISBN-978-9955-20-306-3
2. KUBBA, Sam. Leed Practices. Certification and accreditation handbook. Chapter 6-green materials and products. 2009, p. 151-209.

SYNTHESIS OF BENZENESULFONAMIDE-BEARING AZOLE DERIVATIVES AS HUMAN CARBONIC ANHYDRASE INHIBITORS

Benas Balandis^{1*}, Vaida Paketurytė², Tomas Šimkūnas², Daumantas Matulis², Asta Zubrienė², Vytautas Mickevičius¹

¹ Department of Organic Chemistry, Kaunas University of Technology, Kaunas, Lithuania

² Department of Biothermodynamics and Drug Design, Institute of Biotechnology, Life Sciences Center, Vilnius University, Vilnius, Lithuania

*benas.balandis@ktu.edu

Reversible hydration of CO₂ to protons and bicarbonate is catalyzed by twelve alpha carbonic anhydrase (CA) isozymes found in human body. This is a crucial reaction for the respiratory processes and CO₂ transport between tissues, in pH regulation and homeostasis [1]. Increased expression levels of several CA isozymes are associated with many diseases. CAs are established therapeutic targets of cancer (CA IX and CA XII), glaucoma (CA II, CA IV, CA XII) and obesity (CA VA and CA VB). Currently, most of the research is focused on designing and developing inhibitors against CA IX that show potential for treating solid tumors [2].

Pyrroles **2a,b** were obtained from hydrazides **1a,b** by their reactions with hexane-2,5-dione in propan-2-ol at reflux (Scheme 1). Furthermore, there was an attempt to synthesize 3,5-dimethylpyrroles using the same method. Unfortunately, only one of desired products (compound **3**) was obtained. In attempt to synthesize non-chlorinated analogue of compound **3**, pyrazole **4** was isolated from reaction mixture. It was suggested, that due to acidic properties of pentane-2,4-dione, 2-pyrrolidone ring closure had occurred during the reaction. However, it is suspected that some steric hindrance, which occurs due to chlorine substitute at C-2 of phenyl ring, prevents the closure of 2-pyrrolidone ring during synthesis of compound **3**. Furthermore, reactions of hydrazides **1a,b** with corresponding methyl or phenyl isothiocyanate in DMF led to the formation of carbothioamides **5,6a,b**, which were further cyclized into triazoles **7,8a,b**.

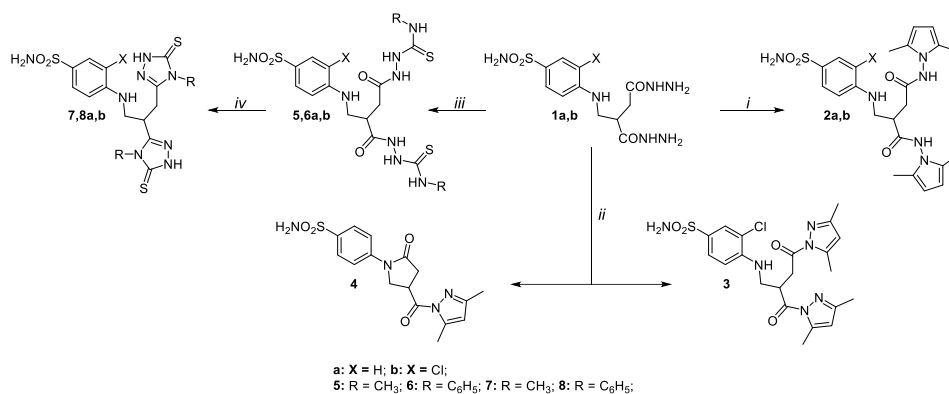

Reaction conditions: i) hexane-2,5-dione, propan-2-ol, reflux, 5 h; ii) pentane-2,4-dione, reflux, 5h;
iii) corresponding isothiocyanate, DMF, r.t., 4-6 h; iv) 2% KOH, r.t., 8 h;

Scheme 1. Synthesis of benzenesulfonamide-bearing azole derivatives.

The structures of all synthesized compounds have been confirmed by the data of ¹H and ¹³C NMR, FT-IR spectroscopy as well as mass spectrometry data. Compound binding to human CA isoforms was measured by fluorescent thermal shift assay. The compounds bound CAs with submicromolar affinity.

References

1. Aggarwal, M., et al. *J. Enzyme Inhib. Med. Chem.* 2013, **28**, 267–277.
2. R. G. Gieling, et al. *Bioorg. Med. Chem.* 2019, **21**, 1470–1476.

SYNTHESIS AND CHARACTERIZATION OF NEW POLYCYCLIC NITROGEN HETEROCYCLE COMPOUNDS VIA MULTICOMPONENT REACTIONS FROM 3-ALKOXY-1H-PYRAZOLE-4-CARBALDEHYDES

Viktorija Dargytė^{1,2*}, Eglė Arbačiauskienė¹, Aurimas Bieliauskas², Algirdas Šačkus^{1,2}.

¹*Department of Organic Chemistry, Kaunas University of Technology, Radvilėnų pl. 19, Kaunas LT-50254, Lithuania*

²*Institute of Synthetic Chemistry, Kaunas University of Technology, K. Baršausko g. 59, Kaunas LT-51423, Lithuania*

* *viktorija.dargyte@ktu.lt*

Multicomponent Reactions (MCRs) in which three or more starting materials react to form a product, where basically all or most of the atoms contribute to the newly formed derivative, are considered to be an important methodological arsenal in synthetic and medicinal chemistry [1]. These reactions have been strategically employed in various synthetic transformations comparing to classical methods that usually involve many steps with difficult procedures. MCRs exhibit advantages such as atom economy and waste prevention, because of the reduced number of work-up, extraction and purification procedures [2]. Therefore MCRs are often considered as useful alternative to sequential multistep synthesis.

Pyrazole containing compounds are considered pharmacologically important because of many biological activities such as antioxidant, antibacterial, anticancer, anti-inflammatory and more [3,4]. This heterocyclic moiety can be found in structures of many well-known drugs for different therapeutic treatments.

In order to explore synthesis of novel pyrazole-containing by MCRs, 3-substituted 1*H*-pyrazole-4-carbaldehyde was used as a starting material. A one-stage four-component reaction was optimized and successfully applied to obtain novel 6-amino-3-methyl-4-(1-phenyl-1*H*-pyrazol-4-yl)-2,4-dihydropyrano[2,3-*c*]pyrazole-5-carbonitrile which was further subjected to AlCl₃ catalyzed Friedländer reaction [5]. A series of novel polycyclic 2*H*-pyrazolo[4',3':5,6]pyrano[2,3-*b*]quinoline-5-amine derivatives were obtained in fair to good yields. Also a multicomponent Hantzsch pyridine synthesis was used for the synthesis of 1*H*-pyrazol-4-yl-2,6-dimethyl-1,4-dihydropyridine-3,5-dicarboxylates that were further oxidised to 1*H*-pyrazol-4-yl-2,6-dimethylpyridine-3,5-dicarboxylates. The structures of the synthesized compounds were confirmed by ¹H, ¹³C and ¹⁵N NMR spectroscopical investigation.

References

1. C. S. Graebin, F. V. Ribeiro. *Curr. Org. Synth.* **16** (2019) 855 - 899.
2. K. Hussain, D. Wadhwa. *Int. J. Org. Chem.*, **4** (2014) 174-181.
3. A. Ansari, A. Ali. *New J. Chem.*, **41** (2017), 16.
4. M. J. Naim, O. Alam .et al *J Pharm Bioallied Sci.* **8** (2016) 2-17
5. M. Chioua, J. Perez-Peña. *Med. Chem.* **7** (2015) 845-855

SYNTHESIS AND EVALUATION OF HYDRAZONE COMPOUNDS AS CARBONIC ANHYDRASE INHIBITORS

Liucija Urbelytė¹, Martynas Bagdonas², Birutė Grybaitė¹, Rita Vaickelionienė¹,
Daumantas Matulis², Asta Zubrienė², Vytautas Mickevičius¹

¹Department of Organic Chemistry, Kaunas University of Technology, Kaunas, Lithuania

²Department of Biothermodynamics and Drug Design, Institute of Biotechnology, Life Sciences Center, Vilnius University, Saulėtekio 7, Vilnius, Lithuania

birute.grybaite@ktu.edu

Carbonic anhydrases (CAs) are enzymes implicated in a wide range of diseases, including epilepsy, obesity, glaucoma and cancer. Selective inhibition of CAs by synthetic inhibitors-drugs could be used for their treatment. Primary sulfonamides are the most important class of CA inhibitors [1–2]. In this study a group of 4-substituted-benzenesulfonamides bearing hydrazone moieties (Fig. 1) was synthesized and compound binding affinity to CA isozymes was evaluated.

In the synthesis, compound **1** was alkylated with methyl bromoacetate in ethanol to give ester **2**. Ethyl 2-[(2,6-dichloro-4-sulfamoylphenyl)amino]acetate (**3**) was synthesized by treating **2** with HCl in the presence of hydrogen peroxide. The obtained esters **2**, **3** were converted to the hydrazides **4**, **5**. The prepared starting compounds **4**, **5** were treated with various aldehydes or ketones and hydrazone-type compounds **6-13** were obtained.

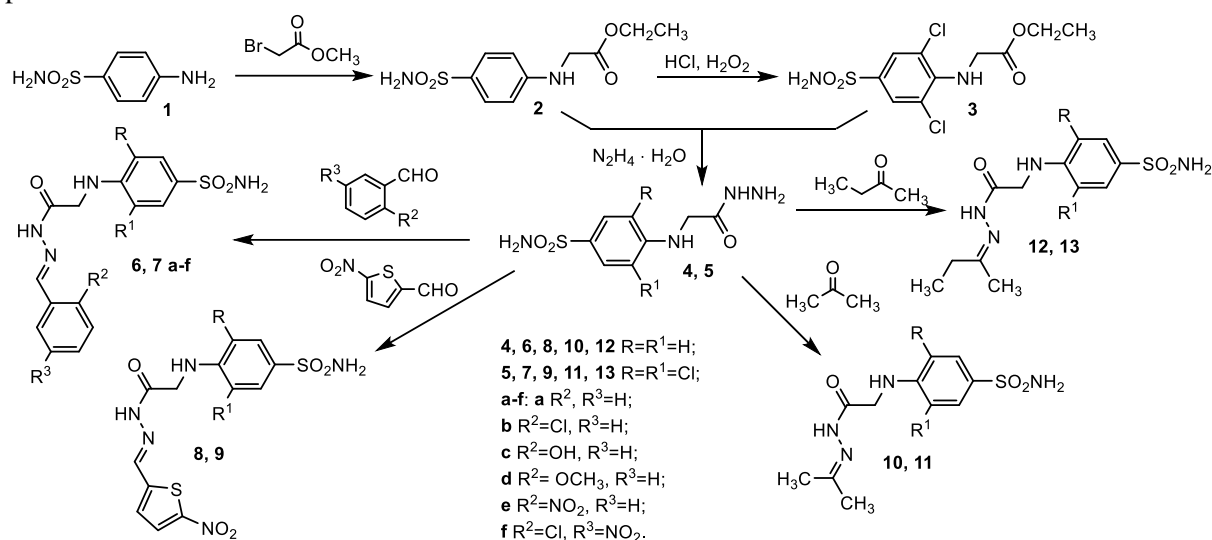

Fig. 1. Synthesis of substituted benzenesulfonamides **2-13**

The binding affinity of synthesized hydrazone-bearing derivatives for eight carbonic anhydrase isozymes was determined. Several compounds exhibited low nanomolar dissociation constants for isozyme CA VB, which is implicated in diseases of the central nervous system and obesity.

References

- Linkuvienė V, Zubrienė A, Manakova et al. *Quarterly Reviews of Biophysics*. 2018. **51**. e10.
- Frost S., McKenna R. (Ed.) *Subcellular Biochemistry*. 2014. Springer Netherlands, p. 430.

4-ISOPROPYL-6-(1-SUBSTITUTED 1H-IMIDAZOL-5-YL)BENZENE-1,3-DIOLS AS POTENTIAL HSP90 INHIBITORS

Paulina Kaziukonytė^{1*}, Egidijus Kazlauskas², Algirdas Brukštus¹

¹ Faculty of Chemistry and Geosciences, Vilnius University, Vilnius, Lithuania

² Life Sciences Center, Vilnius University, Vilnius, Lithuania

* paulina.kaziukonyte@chgf.vu.lt

Heat shock protein 90 (Hsp90) is an ATP-dependent molecular chaperone responsible for maintaining the conformation, stability and function of its client proteins. It constitutes 1-2% of total cell proteins and the amount is doubled in cellular stress conditions [1]. Hsp90 clients include many oncogenic proteins responsible for cell cycle progression, cellular proliferation, invasion and metastasis. Moreover, studies show that Hsp90 shows a higher affinity to small-molecule inhibitors in malignant cells than in normal cells [2]. Hence making Hsp90 a promising target for cancer therapy.

Hsp90 inhibitors may be categorized according to their structure. The major class under investigation is molecules containing resorcinol moiety, that are based on the natural compound Radicicol. Active synthetic structures usually contain an alkyl group in the 4th position and a 5-membered ring in the 6th position, connected to another substitute, such as in compound Ganetespiib, currently undergoing clinical trials [3].

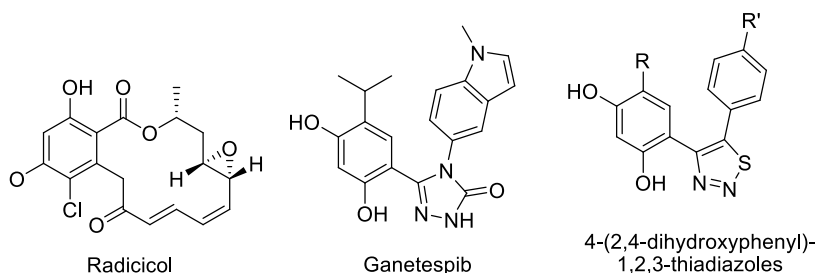

In continuance to our work where a set of 4-(2,4-dihydroxyphenyl)-1,2,3-thiadiazoles were studied [4], we designed a synthetic pathway to obtain 4-isopropyl-6-(1-substituted 1H-imidazol-5-yl)benzene-1,3-diols. 2,4-dihydroxy-5-isopropylbenzaldehyde **1** and primary amines gave imines **2a-p**, which were used in cyclization with 1-(isocyanomethanesulfonyl)-4-methylbenzene to form imidazoles **3a-p**. The biological activity is to be discussed in the poster presentation.

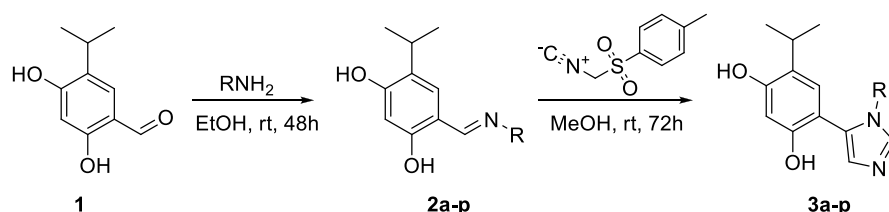

References

1. J. C. Young, V. R. Agashe, K. Siegers, F. U. Hartl. *Nat. Rev. Mol. Cell Biol.* **5** (2004) 781-91.
2. Y. Miyata, H. Nakamoto, L. Neckers. *Curr. Pharm. Des.* **19** (2013) 347-365.
3. R. N. Pillai, D. A. Fennell, V. Kovcin, T.-E. Ciuleanu, R. Ramlau, D. Kowalski, M. Schenker, I. Yalcin, F. Teofilovici, V. M. Vukovic, S. S. Ramalingam. *J. Clin. Oncol.* **38** (2020) 613-622.
4. E. Kazlauskas, A. Brukštus, H. Petrikas, V. Petrikaitė, I. Čikotienė, D. Matulis. *Anticancer Agents Med. Chem.* **17** (2017) 1593-1603.

SYNTHESIS OF TIOPHENE MODIFIED BODIPY BASED POLARITY SENSORS AND THEIR PHOTOPHYSICAL PROPERTIES IN LIPID MEMBRANES

Rokas Žvirblis^{1*}, Jelena Dodonova¹, Aurimas Vyšniauskas²

¹ Department of Organic Chemistry, Vilnius University, Vilnius, Lithuania

² Department of Molecular Compounds Physics, Center for Physical Sciences and Technology, Vilnius, Lithuania

* rokas.zvirblis@chgf.stud.vu.lt

Lipid raft hypothesis suggests that cell membrane is composed of rigid compartments (liquid-ordered phase Lo) enriched with sphingolipids and cholesterol floating in the sea of glycerophospholipids (liquid-disordered phase Ld) [1]. It has been shown that Lo phase is involved in many normal cellular processes such as signal transduction and cholesterol homeostasis, while also being significant in evolution of neurodegenerative diseases such as Alzheimer's [2]. To elucidate the importance of lipid rafts for cellular processes it is important to visualize these domains in living cells. This can be achieved by environment-sensitive dyes that can discern between Ld and Lo phases based on their ability to sense differences in polarity [3]. Probes that sense polarity by their fluorescence lifetime are immensely useful in cell imaging by using FLIM (*fluorescence lifetime imaging microscopy*) [4]. In this communication we report four red-emitting BODIPY polarity sensors that were synthesized and tested in model lipid membranes (Fig. 1.). Initial BODIPY fluorophores were synthesized by methods well described in literature [5]. Afterwards we introduced bromine atoms into the 2,6 and 2,3,5,6 positions of BODIPY core to produce brominated dyes. Finally, Pd-catalyzed cross-coupling reaction between brominated dyes and 2-(tributylstannyl)thiophene was employed to produce red-emitting polarity probes. After synthesis, fluorophores were inserted into LUV's (large unilamellar vesicles) that were produced by extrusion. Ld liposomes were formed from DOPC, while Lo phase was obtained from a mixture of DOPC/DPPC and cholesterol. The fluorescence lifetime of all the probes was shorter in Ld phase. This can be explained by the fact that our probes have faster decays in polar environments. On the other hand, the difference of fluorescence lifetimes was higher for disubstituted probes (-OC₁₀H₂₁: 0.314 ns; -OC₁₆H₃₃: 0.439 ns) than for the tetrasubstituted ones (-OC₁₀H₂₁: 0.084 ns; -OC₁₆H₃₃: 0.129 ns), meaning that BDP-(Tioph)₂ fluorophores can discriminate lipid rafts from the Ld phase more effectively than BDP-(Tioph)₄ probes. Also, it is important to notice that the length of the alkoxy group at the meso position does not significantly affect the photophysical properties of these dyes.

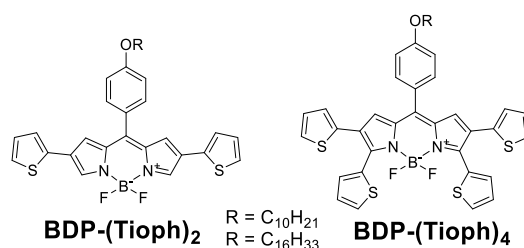

Fig. 1. Di- and tetra- substituted BODIPY polarity sensors.

RŽ thanks to European Social Fund for funding this project (No. 09.3.3-LMT-K-712-22-0167) under the grant agreement with Lithuanian Academy of Sciences.

References

1. K. Simons, E. Ikonen. *Nature* **387** (1997) 569-572.
2. J. V. Rushworth, N. M. Hooper. *J. Alzheimer's Dis.* (2011) 14 pages.
3. A. Klymchenko, R. Kreder. *Chemistry and Biology* **21** (2014) 97-113.
4. D. Owen, A. Magenau, D. Williamson, L. Gaus. *Bioessays* **34** (2012) 739-747.
5. J.A. Levitt, et al. *J. Phys. Chem. C* **113** (2009) 11634-11642.

IMMOBILIZATION OF BIOACTIVE COMPOUNDS IN AMPHOTERIC STARCH DERIVATIVES

Migle Babelyte*, Ramune Rutkaite

Department of Polymer Chemistry and Technology, Kaunas University of Technology, Kaunas, Lithuania
**migle.babelyte@ktu.edu*

Amphoteric starch contains both cationic and anionic groups in the same molecule. Cationic starch derivatives are starch ethers prepared by using tertiary amino or quaternary ammonium groups containing reagents. Meanwhile, anionic starches can be synthesized by introducing phosphate, phosphonate, sulfate, sulfonate or carboxyl groups into starch molecules. The introduction of positively and negatively charged groups into starch may be realized by using several approaches: firstly anionization and thereafter cationization or firstly cationization and after that anionization.

Bioactive compounds such as caffeic acid and natural green coffee bean extract possess good antimicrobial and antioxidant properties. However, these compounds are unstable and quickly lose their beneficial properties. The biological activity of phenolic compounds could be preserved by the immobilization in amphoteric starch derivatives which have both positively and negatively charged groups and could form complexes with negatively and positively charged compounds.

The aim of the present work was to prepare amphoteric hydroxyethyl starches (CHES/AHES) of different composition and investigate their interaction with caffeic acid (CA) and natural green coffee bean extract (GCBE).

Preparation of CHES/AHES has been achieved by using two - step reaction approach as demonstrated in the synthesis scheme in Fig. 1.

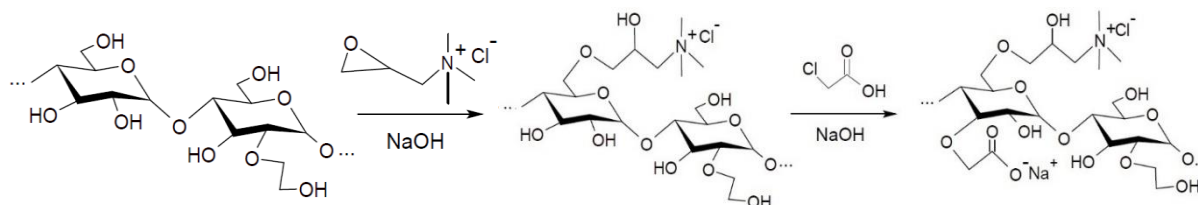

Fig. 1. Two – step synthesis scheme for preparation of amphoteric starches

Firstly, cationic hydroxyethyl starches (CHES) were prepared by the reaction of hydroxyethyl starch with (2,3-epoxypropyl)trimethylammonium chloride in the presence of sodium hydroxide at 45°C for 24 h [1]. Synthesized CHES then were reacted with monochloroacetic acid in alkaline solution at 55 °C for 48 h. Consequently, by changing the molar ratios of cationic and anionic reagents four different CHES/AHES samples were obtained.

Water soluble amphoteric hydroxyethyl starch derivatives were used for polyelectrolyte complex formation in water between amphoteric hydroxyethyl starch derivatives and components of GCBE. Water insoluble amphoteric hydroxyethyl starch derivatives were used for interaction with CA acid via adsorption process.

References

1. R. Rutkaitė, J. Bendoraitienė, R. Klimavičiūtė, E. Lekniūtė, I. Narmontaitė, V. Šinkūnaitė. Charged starch nanoparticles prepared by polyelectrolyte complex formation. *Chemija*, 2012, Vol. 23; No. 4; p. 328 – 335.

SYNTHESIS OF PYRIMIDINES BEARING HYDROXAMIC ACID AND 1,3,4-OXADIAZOLE-2-THIONE MOIETIES AS POTENTIAL HDAC INHIBITORS

Virginija Jakubkienė^{1*}, Gabrielius Ernis Valiulis¹, Mantas Žvirblis¹, Ieva Labalaukytė¹, Asta Zubrienė², Markus Schweipert³, Franz-Josef Meyer-Almes³, Daumantas Matulis²

¹ Institute of Chemistry, Faculty of Chemistry and Geosciences, Vilnius University, Vilnius, Lithuania

² Institute of Biotechnology, Life Sciences Center, Vilnius University, Vilnius, Lithuania

³ Department of Chemical Engineering and Biotechnology, University of Applied Sciences, Darmstadt, Germany

* e-mail: virginija.jakubkiene@chf.vu.lt

Histone deacetylases (HDACs) are a family of enzymes that modulate the acetylation of histones and non-histone proteins. HDACs play an essential role in many biological processes such as gene regulation, transcription, cell proliferation, angiogenesis, migration, differentiation and metastasis [1]. HDACs have been proven to be promising therapeutic targets for cancer treatment, particularly of hematological malignancies, based on the successful clinical approval of six HDAC inhibitors to date: vorinostat, romidepsin, belinostat, panobinostat, pracinostat, and chidamide [2]. Pyrimidines are widely spread in nature and occupy an exclusive place, mainly due to their importance for living organisms and wide range of biological activities of their derivatives [3, 4]. Pyrimidine moiety is a building block for several new drugs introduced to the market every year [5]. In this context and continuing our work dedicated to the development of efficient methods for the synthesis of functionalized pyrimidines [6, 7], we present herein the synthesis of pyrimidine-based hydroxamic acids and 1,3,4-oxadiazole-2-thiones **1–3**.

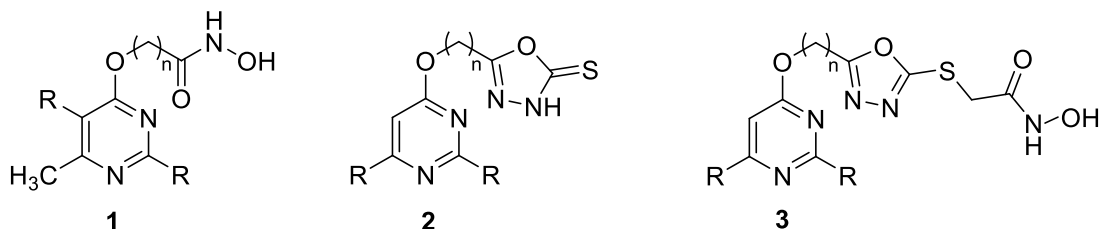

The inhibitory activity of compounds **1–3** against HDAC4 and HDAC8 isoforms were tested. Several compounds were micromolar HDAC inhibitors.

References

1. X. Peng, Z. Sun, P. Kuang, J. Chen. *Eur. J. Med. Chem.* **208** (2020) 112831.
2. S. Banerjee, N. Adhikari, S. A. Amin, T. Jha. *Eur. J. Med. Chem.* **164** (2019) 214.
3. A. P. Keche, G. D. Hatnapure, R. H. Tale, A. H. Rodge et al. *Bioorg. Med. Chem. Letters* **22** (2012) 3445.
4. E. De Clercq, G. Li. *Clin. Microbiol. Rev.* **29** (2016) 695.
5. H. X. Ding, C. A. Leverett, R. E. Kyne (Jr.) K. K.-C. Liu et al. *Bioorg. Med. Chem.* **23** (2015) 1895.
6. V. Jakubkienė, V. Linkus, I. Čikotienė. *Arkivoc* **vii** (2018) 154.
7. V. Jakubkiene, E. Vaiciunaite, K. Kriukaite, J. Didzgalvis, S. Tumkevicius. *Synth. Commun.* **48** (2018) 1974.

BROMINE CONTAINING NAPHTHALIMIDES EXHIBITING ROOM-TEMPERATURE PHOSPHORESCENCE

Naveen Masimukku¹, Dalius Gudeika¹, Asta Dabulienė¹, Melika Ghasemi¹, Malek Mahmoudi¹, Dmytro Volyniuk¹, Juozas V. Grazulevicius¹

¹Department of Polymer Chemistry and Technology, Kaunas university of technology, Radvilenu plentas 19, LT-50254, Kaunas, Lithuania
naveen.masimukku@ktu.edu

Phosphorescence is generally known as the radiative transition between two states with the different spin-multiplicities. This phenomenon is often observed for inorganic materials and organometallic complex materials [1]. Recently, room-temperature phosphorescence (RTP) from pure organic materials has attracted great attention owing to its various functional applications in organic light-emitting diodes, digital security, optical recording devices, sensors, for bioimaging etc. [2]. Since phosphorescence originates because of a spin-forbidden transition, decay times of phosphorescence (10^{-6} to 10^{-2} s) are typically longer than those of fluorescence (10^{-9} to 10^{-7} s) [3]. The triplet excited state of RTP material provides longer lifetimes of emission and this facilitates the design of relatively inexpensive optical sensing systems based on decay-time measurements. The interference from short-lived fluorescence and scattering light can be easily avoided using an appropriate delay time and the larger Stokes' shifts of the RTP process simplifying the spectral separation between the excitation light and the phosphorescence emission [5]. Four differently bromine substituted naphthalimide derivatives synthesized in two steps, i.e. bromination and imidization. The films of all the synthesized compounds exhibited room-temperature phosphorescence. Thermal properties were studied by thermogravimetric analysis and differential scanning calorimetry. Electrochemical properties studied by cyclic voltammetry properties and photophysical properties will also be reported.

References

1. M. Huili, L. Anqi, F. Lishun, W. Shan, A. Zhongfu, S. Huifang, and H. Wei // Room-Temperature Phosphorescence in Metal-Free Organic Materials, *annalen der physik*, 2019, **531**, 1800482-1800484.
2. O.S. Wolfbeis, *Fiber-Optic Chemical Sensors and Biosensors // Analytical Chemistry*, 2006, **78**, 3859-3861.
3. Kenry, C. Chen, B. Liu // Enhancing the performance of pure organic room-temperature phosphorescent luminophores, *Nature Communications*, 2019, **10**, 2111-2112.
4. I. Sanchez-Barragan, J.M Costa-Fernandez, M. Valledor, J.C Campo, A. Sanz-Medel // Room-temperature phosphorescence (RTP) for optical sensing, *Trends in Analytical Chemistry*, 2006, **25**, 10-12.

SYNTHESIS AND BIOLOGICAL ACTIVITY OF ALDIMINE DERIVATIVES BEARING 1,2,4-TRIAZOLE-3-THIOLYL MOIETY

Aida Šermukšnytė^{1*}, Ilona Jonuškienė¹, Kristina Kantminienė², Ingrida Tumosienė¹

¹ Department of Organic Chemistry, Kaunas University of Technology, Kaunas

² Department of Physical and Inorganic Chemistry, Kaunas University of Technology, Kaunas

* aida.sermuksnyte@ktu.edu

1,2,4-Triazole scaffold is a promising pharmacophore due to biological activity of its derivatives and extensive structural modification capability. 1,2,4-Triazole-3-thione derivatives as well as aldimine derivatives bearing various heterocyclic moieties possess antimicrobial, antioxidant, anticancer, anticonvulsant, anti-inflammatory, antiviral, antipyretic, etc. activity.

The target aldimine derivatives **4-13** were synthesized from 1,2,4-triazol-3-yl-thioacetohydrazide **3** and corresponding aldehydes in methanol (Scheme 1) [1,2].

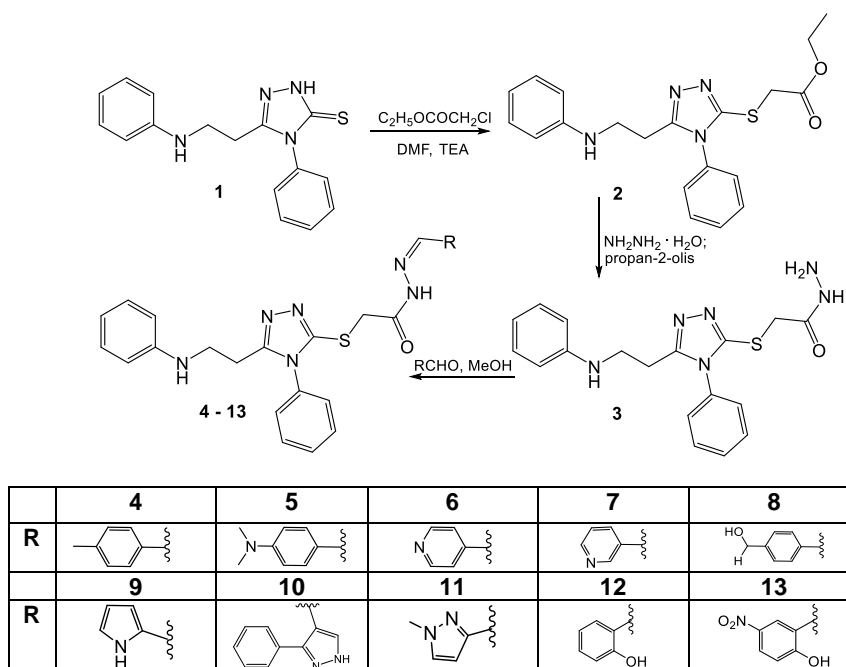

Scheme 1. Synthesis of 1,2,4-triazol-3-yl-thioacetohydrazides **4-13**

Screening of the antioxidant activity of the synthesized compounds **4-13** has revealed that *N'*-(4-methylbenzylidene)-2-((4-phenyl-5-(2-(phenylamino)ethyl)-4*H*-1,2,4-triazol-3-yl)thio)acetohydrazide (**4**) possesses the highest DPPH radical scavenging activity as determined by DPPH radical scavenging assay and 2-((4-phenyl-5-(2-(phenylamino)ethyl)-4*H*-1,2,4-triazol-3-yl)thio)-*N'*-(pyridin-3-ylmethylene)acetohydrazide (**7**) exhibits the strongest reducing activity as identified by the reducing power assay. 2-((4-Phenyl-5-(2-(phenylamino)ethyl)-4*H*-1,2,4-triazol-3-yl)thio)-*N'*-(pyridin-4-ylmethylene)acetohydrazide (**6**) has shown the highest antibacterial activity against *Escherichia coli*, *Rhizobium radiobacter*, and *Xanthomonas campestris* bacteria among the tested compounds **4-13** by agar diffusion method.

Acknowledgements. The research leading to these results has received a funding from European Social Fund (project No 09.3.3-LMT-K-712-22-0083) under grant agreement with the Research Council of Lithuania (LMTLT).

References

1. I. Tumosienė, K. Kantminienė, I. Jonuškienė, A. Peleckis, S. Belyakov, V. Mickevičius. *Molecules*, 24 (2019) 971.
2. I. Tumosienė, K. Kantminienė, A. Pavilonis, Ž. Maželienė, Z.J. Beresnevičius. *Heterocycles*, 78 (2009) 59.

SYNTHESIS OF AZOLES AND THEIR ANTIOXIDANT AND ANTIBACTERIAL ACTIVITY

Ingrida Tumosienė¹, Kristina Kantminienė², Ilona Jonuškienė¹

¹ Department of Organic Chemistry, Kaunas University of Technology, Kaunas

² Department of Physical and Inorganic Chemistry, Kaunas University of Technology, Kaunas

* kristina.kantminiene@ktu.lt

Reactive oxygen species (ROS) are responsible for many cell disorders and the development of many undesired processes. Unfavourable environmental conditions result in the overproduction of ROS that leads to oxidative cell injuries at high concentrations. There is a growing interest in search of new bioactive compounds possessing antioxidant properties. Derivatives containing the 1,3,4-thiadiazole and 1,3,4-oxadiazole nuclei exhibit a wide range of pharmacological activities that include antioxidant, antimicrobial, anticancer and antitubercular properties [1, 2].

Reactions of *N*-(4-methylphenyl)- β -alanine hydrazide with phenyl isocyanate or phenyl isothiocyanate, depending on the molar ratio of the reacting substances, gave semicarbazides/semithiocarbazides or their phenylcarbamoyl derivatives, which underwent cyclisation under acidic conditions to provide target 1,3,4-oxadiazole or 1,3,4-thiadiazole derivatives [3].

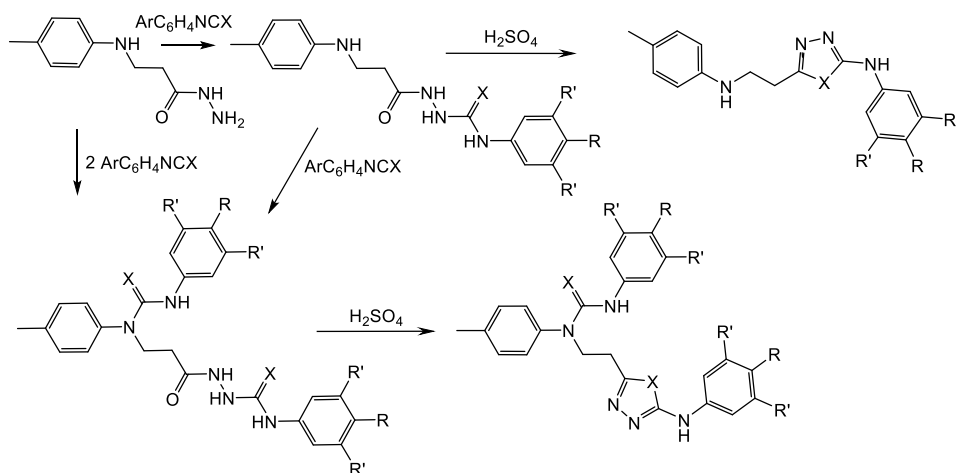

Scheme. Synthesis of azoles

Screening of the antioxidant activity of the synthesized compounds by ferric reducing antioxidant power assay (FRAP) has revealed that *N*-(3,5-dimethylphenyl)-5-{2-[(4-methylphenyl)amino]ethyl}-1,3,4-oxadiazole-2-amine and 3-(4-methylphenyl)-1-phenyl-3-{2-[5-(phenylamino)-1,3,4-thiadiazol-2-yl]ethyl}thiourea possess the highest antioxidant activity in comparison with the synthetic antioxidant butylated hydroxytoluene (BHT).

N-(4-Methylphenyl)-5-{2-[(4-methylphenyl)amino]ethyl}-1,3,4-thiadiazole-2-amine has been identified as possessing the highest antibacterial activity against *Escherichia coli*, *Xanthomonas campestris*, and *Bacillus subtilis* bacteria by agar diffusion method.

References

1. F. Alam. J. Appl. Pharm. Res. **6** (2018) 10.
2. H.Z. Zhang, Z.L. Zhao, C.H. Zhou, Eur. J. Med. Chem. **144** (2018) 444.
3. I. Tumosienė, I. Jonuškienė, K. Kantminienė, Z.J. Beresnevičius. Monatsh. Chem. **143** (2012) 1441.

SYNTHESIS OF 3-((4-(N-(5-METHYLISOXAZOL-3-YL)SULFAMOYL)PHENYL)AMINO)PROPANOIC ACID DERIVATIVES

Rita Vaickelionienė*, Birutė Sapijanskaitė-Banevič, Birutė Grybaitė,
Giedrius Vaickelionis, Vytautas Mickevičius
Department of Organic Chemistry, Kaunas University of Technology, Kaunas, Lithuania

* e-mail rita.vaickelioniene@ktu.lt

Isoxazoles represent a large group of compounds, the most of which display broad spectrum of pharmacological properties such as antibacterial [1], anti-inflammatory [2], anticancer [3], antioxidant [4]. The literature survey showed that the substitution on the isoxazole ring provides different activity of the compounds.

Taking into account the above-mentioned facts, as a starting material for the study we have selected a 4-amino-*N*-(5-methylisoxazol-3-yl)benzenesulfonamide (**1**), which is known as *Sulfamethoxazole*, an antibiotic used for the treatment of the bacterial infections such as bronchitis, urinary tract infections, prostatitis as well as is effective against both Gram negative and positive bacteria [5].

An interaction of sulfonamide **1** with acrylic acid in water at reflux afforded β -amino acid **2** (Scheme 1) in 95% yield. The esterification of the obtained acid **2** was performed with methanol, and the formed methyl ester **3** was applied for the preparation of hydrazide **4**. The reaction was performed with hydrazine monohydrate in propan-2-ol at reflux for 24 hours and gave acid hydrazide **4**, which then was condensed with various aromatic aldehydes to form the appropriate hydrazones **5a–e**. The reactions were carried out in 1,4-dioxane at reflux for 24 hours in the presence of a catalytic amount of hydrochloric acid.

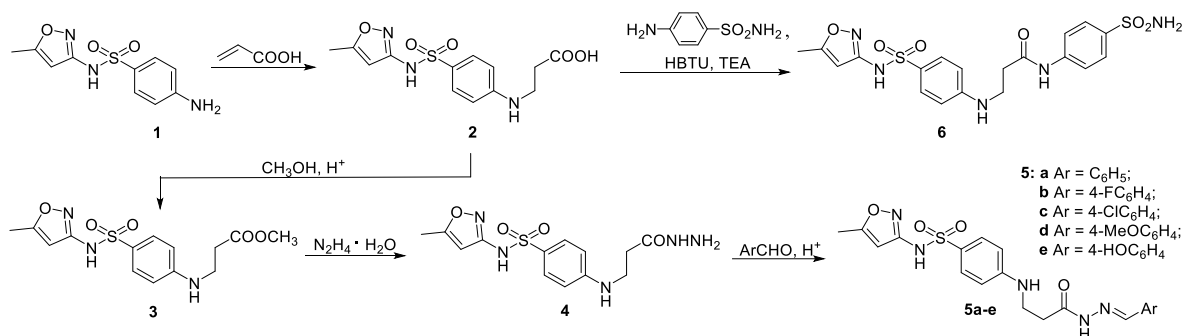

Scheme 1. Synthesis of 4-amino-*N*-(5-methylisoxazol-3-yl)benzenesulfonamide derivatives **2–6**.

To expand the variety of sulfonamide derivatives the amidation reaction of acid **2** was carried out. It was performed in DMSO at room temperature, at stirring for 20 h, in the presence of HBTU as a coupling agent in combination with TEA and gave the amide **6**. The synthesized compounds were confirmed by their spectroscopic and elemental analyses data.

References

1. Bommagani, J. R. Yerrabelly, M. Chitneni, G. Thalari, N. R. Vadiyala, S. K. Boda, P. R. Chitneni. *Chem. Data Collect.* **31** (2021) 100629.
2. E. K. A. Abdelall. *Bioorg. Chem.* **94** (2020) 103441.
3. B. Lin, W.-H. Zhang, D.-D. Wang, Y. Gong, Q.-D. Wei, X.-L. Liu, T.-T. Feng, Y. Zhou, W.-Ch. Yuan. *Tetrahedron* **73** (2017), 5176.
4. A. Padmaja, C. Rajasekhar, A. Muralikrishna, V. Padmavathi. *Eur. J. Med. Chem.* **46** (2011) 5034.
5. Sulfamethoxazole. DrugBank online. Retrieved on 16 June 2021.

MODELING OF CONCENTRATION QUENCHING IN TWO-DIMENSIONAL SYSTEMS

Sandra Barysaite^{1,2*}, Andrius Gelzinis^{1,2}, Jevgenij Chmeliov^{1,2}, Leonas Valkunas^{1,2}

¹ Faculty of Physics, Vilnius University, Vilnius, Lithuania

² Department of Molecular Compound Physics, Centre for Physical Sciences and Technology, Vilnius, Lithuania.

* sandra.barysaite@ff.stud.vu.lt

The phenomenon of concentration quenching has been investigated throughout the last century, however, its origin is not fully understood to this day. An example of such occurrence has been observed in chlorophyll solutions: at higher concentrations the relative fluorescence intensity becomes dependent on concentration and starts decreasing [1]. It is important to note that in artificial systems the fluorescence is usually significantly quenched at fluorophore concentrations typical to that of unquenched *in vivo* photosynthetic systems.

In this work, concentration quenching in a two-dimensional system was simulated using approach similar to Ref. [2]. Molecules were scattered in a certain area using a uniform distribution, and different concentrations were obtained by changing the number of them. When two or more molecules were closer to each other than a certain distance (R_{trap}), they formed a trap; excitation, after reaching a trap, could not escape. At the initial time moment, excitation was distributed equally among all non-trap molecules. Time dependence of the total excitation probability was calculated by solving the system of kinetic equations with energy transfer rates between the molecules being proportional to the inverse sixth power of the distance between the molecules, following the Förster level of description. Obtained results are shown in Fig. 1. As expected, we can observe that in larger concentrations quenching is more rapid.

This model was used to fit the experimental data of chlorophylls in monolayers [3], however, it turned out that such a simple model cannot explain the data sufficiently well, and a more sophisticated model will be presented in the conference.

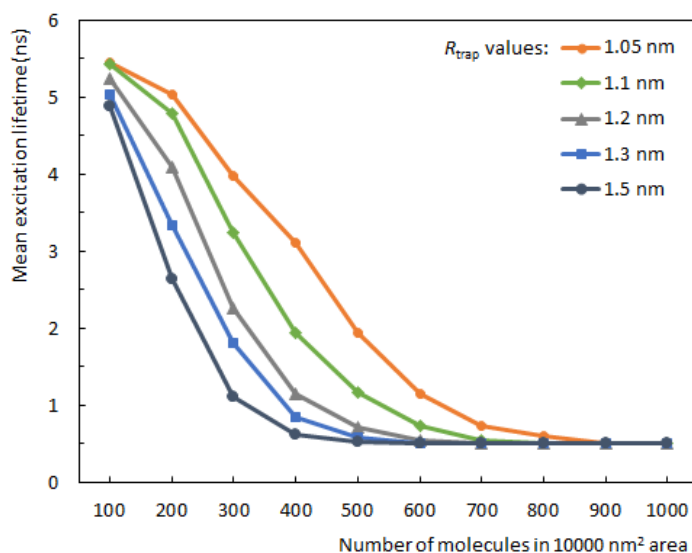

Fig. 1. Dependence of mean excitation lifetime on different molecular concentrations and relative amount of traps.

References

1. G. Beddard, G. Porter, *Nature* **260**, 366–367 (1976).
2. W.-J. Shi, J. Barber, Y. Zhao, *The Journal of Physical Chemistry B* **117** (15), 3976–3982 (2013).
3. M. L. Agrawal, J.-P. Chauvet, L.K. Patterson, *The Journal of Physical Chemistry* **89** (14), 2979–2982 (1985).

MODELING OF INTER-CHLOROPHYLL COUPLINGS IN THE PHOTOSYNTHETIC FCP COMPLEX

Austėja Mikalčiūtė^{1,2}, Andrius Gelžinis^{1,2}, Jevgenij Chmeliov^{1,2}

¹*Institute of Chemical Physics, Faculty of Physics, Vilnius University, Vilnius, Lithuania*

²*Department of Molecular Compound Physics, Centre for Physical Sciences and Technology, Vilnius, Lithuania*
austeja.mikalciute@ff.stud.vu.lt

Photosynthesis has always been one of the most essential processes throughout the development of life on Earth and still has this crucial role today: it allows not only thousands of bacteria, algae and plants to exist but also the codependent animal species to survive. About the same amount of photosynthesis processes are carried out on land and in water, however, it is possible to find photosynthetic organisms in such extremes as deserts or 80 meters deep into the sea [1]. However, one of the most important, but oftentimes forgotten type of photosynthesis-carrying organisms are diatoms – microalgae comprising phytoplankton and accounting for nearly 20 % of global carbon dioxide fixation [2]. Moreover, diatoms have an exceptional light-harvesting complex, fucoxanthin-chlorophyll protein (FCP), which differs from the light-harvesting complex found in higher plants, as it has such chromophores as chlorophyll *c* and fucoxanthin, which guarantee light absorption in the blue-green visible region available in water. Nonetheless, the first crystallographic structure from *Pheodactylum tricornerutum* diatom was identified only in 2019 [3], which can allow developing a more thorough theoretical understanding of FCP.

In this study, the Protein Database structure of FCP retrieved from *Phaeodactylum tricornerutum* [3] was used to model the first excited state of chlorophylls (Chl) and use these results to determine their interaction energy. The first excited state of chosen Chl *a* and *c* pigments was modeled using TD-DFT level of theory with different functionals and basis sets. The best suited functional and basis set combination proved to be CAM-B3LYP/6-31G(d) and the phytol tail of pigments was cropped as it had very little impact on transition dipole moment direction and its absolute value. Then first excited states of all of the chlorophylls from FCP were modeled with CAM-B3LYP/6-31G(d) at TD-DFT level and the transition dipole moments were calculated. The Chl *a* and *c* transition dipole moment ratio was found to be close to the expected value from experimental results: between 2.6 and 2.7, depending on chlorophyll *c* subtype. Then structural information about the alignment of pigments in the protein was used to model interaction of pigments applying point dipole approximation. These calculations indicate that the strongest interactions occur within the crystallographically determined Chl clusters: there is always at least one strong interaction between Chl *c* and *a* and within Chl *a* pair. The Förster energy transfer analysis showed that the inverse energy transfer rate is 1-5 ps in the same chlorophyll cluster, which is a result of strong interchromophore interactions. Moreover, these results also indicate fast energy transfer between chlorophyll *c* and *a*, which is a few picoseconds long and coincides with previous experimental results.

References

1. J. Overmann, H. Cypionka, and N. Pfennig, An extremely low-light adapted phototrophic sulfur bacterium from the Black Sea, *Limnol. Oceanogr.*, 1992, **37**, 150–155.
2. S. Malviya, E. Scalco, S. Audic *et al.*, Insights into global diatom distribution and diversity in the world's ocean, *Proc. Natl. Acad. Sci. U.S.A.*, 2016, **113**, 1516–1525.
3. W. Wang, L.-J. Yu, C. Xu *et al.*, Structural basis for blue-green light harvesting and energy dissipation in diatoms, *Science*, 2019, **363**, 1–8.

MODELING OF SINGLET–SINGLET ANNIHILATION IN MOLECULAR LATTICE

Gabrielė Rankelytė¹, Jevgenij Chmeliov^{1,2}

¹*Institute of Chemical Physics, Faculty of Physics, Vilnius University, Vilnius, Lithuania*

²*Department of Molecular Compound Physics, Centre for Physical Sciences and Technology, Vilnius, Lithuania*
gabriele.rankelyte@ff.stud.vu.lt

Singlet–singlet annihilation is a common phenomenon in molecular structures. It is often difficult to provide experimental conditions that could prevent annihilation; therefore, it might often be necessary to account for annihilation while analyzing data.

Simple annihilation model can be described by rate equation Eq. 1:

$$\frac{dn}{dt} = -\gamma n^2, \quad (1)$$

here $n(t)$ is the mean number of remaining excitations in the system at time t and γ is the rate constant for annihilation. In this model, the size of molecular aggregate, excitation transfer rate across the aggregate, and initial population of excitations are considered to be very large. In order to include finite transfer rate, γ must be considered as a function of time, which for one-dimensional systems at longer times can be approximated by a power law [1]. More precise statistical model accounts for the discrete number of excitations, but still considers the whole aggregate as a supermolecule, resulting in the system of Pauli Master equations [2].

To account for both finite transfer rate and discrete number of excitations in annihilation model, we have chosen to use Monte Carlo method. The model is based on continuous time random walk. After sufficient number of lattices have been generated, the average kinetics of specific initial number of excitations is calculated (Fig. 1). The average kinetics is later recalculated considering that initial distribution of excitations obeys a Poisson distribution. The kinetics is then approximated using Eq. 2 to evaluate the $\gamma(t)$ dependence:

$$\frac{dn}{dt} = -\gamma(t)n^2 - k_{rel}n. \quad (2)$$

Here k_{rel} is the rate constant for relaxation.

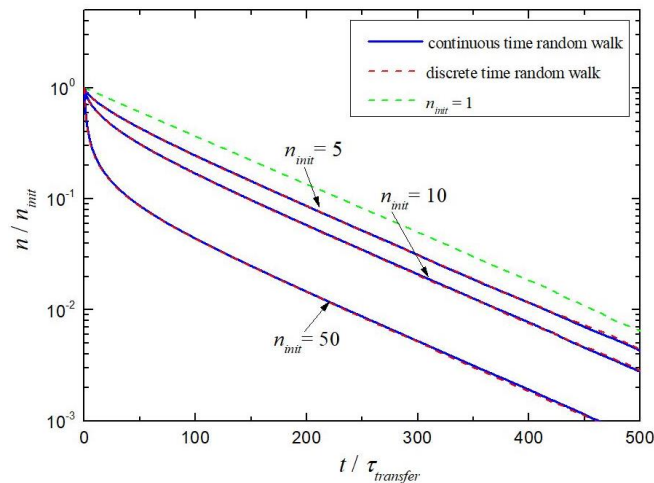

Fig. 1. Excitation population kinetics in one-dimensional aggregate (n_{init} is the initial population size, molecular lattice size is $N = 100$ nodes). When one excitation is left in the lattice, quenching becomes exponential due to linear relaxation (relaxation rate is $k_{rel} = 10^{-2} k_{transfer}$).

References

1. H. van Amerongen, L. Valkunas, R. van Grondelle. *Photosynthetic Excitons*. World Scientific, Singapore, 2000.
2. V. Barzda, V. Gulbinas, R. Kananavicius, V. Cervinskis, H. van Amerongen, R. van Grondelle, L. Valkunas, Singlet-Singlet Annihilation Kinetics in Aggregates and Trimers of LHCII, *Biophys. J.* **80** (2001) 2409–2421.

DEVELOPMENT OF ZINC-NICKEL 3D STRUCTURE ON TITANIUM PLATE FOR HYDROGEN PEROXIDE REDUCTION REACTION

A. Antanaitis^{*}, A. Balčiūnaitė, L. Tamašauskaitė-Tamašiūnaitė, E. Norkus

Department of Catalysis, Center for Physical Sciences and Technology, Vilnius, Lithuania

^{*} augustas.antanaitis9@gmail.com

Zinc-nickel 3D coatings were made on a titanium plate (ZnNi/Ti) by electrochemical deposition from a solution that contained 0.4 M Zn(NO₃)₂ and 2 M NiSO₄. Electroplating was performed under different time and current density conditions: 1) 500 mAcm⁻² for 1 min; 2) 50 mAcm⁻² for 1 min and 500 mAcm⁻² for 5 min; 3) 50 mAcm⁻² for 1.5 min, 250 mAcm⁻² for 1.5 min and 500 mAcm⁻² for 2 min. Coating surface and combination of chemical elements were inspected using scanning electron microscopy, energy-dispersive X-ray spectroscopy, X-ray diffraction, and inductively coupled plasma optical emission spectroscopy. To compare and evaluate the electrocatalytic activity of the coated electrodes for the hydrogen peroxide reduction reaction, a cyclic voltammetry method was used. The cyclic voltammograms were recorded in a 0.1 M KOH and 0.05 M H₂O₂ solution at a potential scan rate of 10 mV s⁻¹ in a potential range from -0.8 to 0.2 V vs. Ag/AgCl at a temperature of 25 °C. The highest electroactivity for hydrogen peroxide reduction reaction was achieved with ZnNi/Ti coating, consisting of 45 at. % of Zn and 55 at. % of Ni.

Acknowledgment. This project has received funding from European Social Fund (project No 09.3.3-LMT-K-712-19-0138) under grant agreement with the Research Council of Lithuania (LMTLT).

PREPARATION AND INVESTIGATION OF 3D ZINC-NICKEL COATINGS FOR OXYGEN EVOLUTION REACTION

A. Balčiūnaitė^{*}, A. Antanaitis, L. Tamašauskaitė-Tamašiūnaitė, E. Norkus

Department of Catalysis, Center for Physical Sciences and Technology, Vilnius, Lithuania

** aldona.balciunaite@ftmc.lt*

Here we present a simple approach to prepare 3D structure zinc-nickel coatings on titanium (ZnNi/Ti) by electrochemical method. ZnNi coatings were electroplated on the Ti surface from a bath containing 1 M Zn(NO₃)₂, and 1 M NiSO₄. The electrochemical deposition was carried out at the different current densities and times: i) 500 mAcm⁻² for 1 min; ii) 50 mAcm⁻² for 1 min and 500 mAcm⁻² for 5 min; iii) 50 mAcm⁻² for 1.5 min, 250 mAcm⁻² for 1.5 min and 500 mAcm⁻² for 2 min. The morphology and composition of the catalysts were examined using scanning electron microscopy, energy dispersive X-ray spectroscopy, X-ray diffraction, and inductively coupled plasma optical emission spectroscopy. The electrocatalytic properties of the prepared ZnNi/Ti catalysts for oxygen evolution reaction were investigated by recording linear scan voltammograms in a 1 M KOH solution at a potential scan rate of 10 mV s⁻¹ in a potential range from OCP up to 1 V vs. Ag/AgCl/KCl_{sat} at a temperature of 25 up to 75 °C. The highest electroactivity for oxygen evolution reaction was obtained using ZnNi/Ti coating, which contains 20 at.% of Zn and 80 at.% of Ni.

Acknowledgment. This project has received funding from European Social Fund (project No 09.3.3-LMT-K-712-19-0138) under grant agreement with the Research Council of Lithuania (LMTLT).

ELECTROCHEMICAL FORMATION AND CHARACTERIZATION OF CALCIUM HYDROXYAPATITE ON Mg ALLOY

Greta Briedytė^{1*}, Asta Grigucevičienė², Alma Ručinskienė²

¹ Vilnius University, Naugarduko 24, LT-03225 Vilnius, Lithuania

²Center for Physical Sciences and Technology, Department of Electrochemical Materials Science, Saulėtekio al. 3, LT-10257 Vilnius, Lithuania

Biodegradable implants are one of the promising areas of Mg and its alloys application. Implant materials must be biocompatible, which is defined as the ability of materials not to cause severe adverse reactions in organisms. Mg is a non-toxic, easily adsorbed element, naturally occurring in the tissues of living organisms and involved in physiological processes. The aim of this work was to electrochemically form calcium hydroxyapatite (CHAp) coatings on AZ31 alloy, identify their composition, structural morphology and corrosive behavior in balance Hanks' salt solution. X-ray diffraction method showed that coating consists of ~ 41% of calcium hydroxyapatite $\text{Ca}_{10}(\text{PO}_4)_6(\text{OH})_2$ and ~ 59% of calcium hydroxylapatite $\text{Ca}_5(\text{PO}_4)_3(\text{OH})$. SEM-EDX and 3D optical microscopy methods revealed that CHAp coatings have dendritic morphology, they are uneven, coarse, highly porous and have large variations in coating thickness (Fig.1). The corrosion behaviour of AZ31 alloy was investigated by electrochemical methods. It was found that CHAp coating increases the resistance of AZ31 to pitting corrosion. CHAp coatings with the best parameters were formed by galvanostatic method with deposition current of $-0.5 \text{ mA}\cdot\text{cm}^{-2}$. As can be seen from Tafel dependences in Figure 2, the open circuit potential of the galvanostatically coated AZ31/CHAp electrodes shifted to a range of more positive values compared to the uncoated AZ31 electrode (curve 4). The largest positive shift of ~0.1V was found for the CHAp coating, with deposition time of 120 min (thickness for reference $13.8\mu\text{m}$).

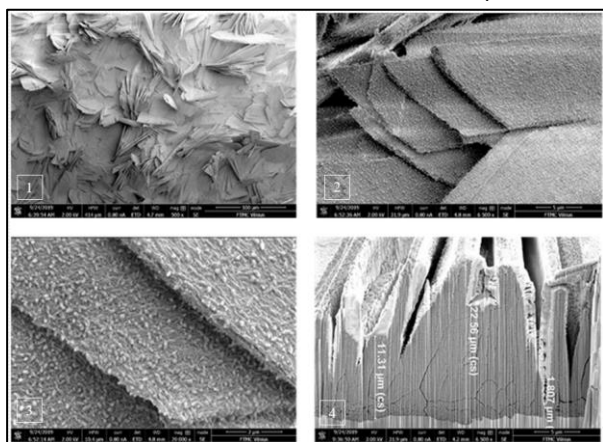

Fig.1. SEM images of surface (1-3) and cross-section (4) of CHAp coating deposited by galvanostatic method ($i_k=0.5 \text{ mA}\cdot\text{cm}^{-2}$, 60 min) at different magnifications: 1 - 500x, 2, 4 - 6500x, 3 - 20000x.

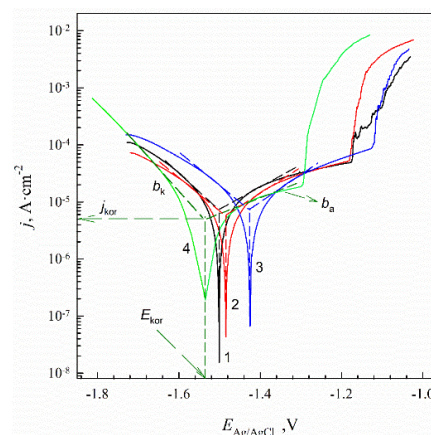

Fig. 2. Tafel plots of AZ31/CHAp electrodes formed by galvanostatic method. CHAp coating deposition current density $i_k=0.5 \text{ mA}\cdot\text{cm}^{-2}$, deposition times: 1- 30 min; 2 - 60 min; 3 - 120 min; 4 - AZ31.

Acknowledgment. The authors thank Dr. Aušra Selskienė for SEM-EDX measurements.

References

1. Z. Grubač, M. Metikos-Hukovic, R. Babic. Electrolyzation growth and characterization of calcium phosphate ceramics on magnesium alloys. *Electrochimica Acta* 109:694-700 (2013).
2. K. Kusnierczyk and M. Basista. Recent advances in research on magnesium alloys and magnesium–calcium phosphate composites as biodegradable implant materials. *Journal of Biomaterials Applications* 31(6): 878-900 (2016).

A NOVEL REDUCED GRAPHENE OXIDE BASED ELECTROCHEMICAL SENSOR FOR THE DETECTION OF DOPAMINE

Justina Gaidukevič^{1,2*}, Rūta Aukštakojsytė², Jurgis Barkauskas², Rasa Pauliukaitė¹

¹Department of Nanoengineering, Center for Physical Sciences and Technology, Savanoriu Ave. 231, LT-02300 Vilnius, Lithuania

²Vilnius University, Faculty of Chemistry and Geosciences, Naugarduko str. 24, LT – 03225, Vilnius, Lithuania.

* justina.gaidukevic@fmc.lt

Dopamine (DA) is a neurotransmitter that plays several important roles in the brain and body. It has been involved in motivation, memory, attention and even regulating body movements [1]. When dopamine is released in large amounts, it creates feelings of pleasure and reward, which motivates you to repeat a specific behavior. In contrast, low levels of dopamine are linked to reduced motivation and decreased enthusiasm for things that would excite most people. Moreover, a common nervous disease that occurs in the deficiency of DA is depression, hallucinosis, Alzheimer's, and Parkinson's [2]. Therefore, the precise determination of DA and the development of sensitive and selective platforms for the detection of DA have become an important issue in clinical diagnosis, especially at a very low concentration.

The aim of this work was to prepare new highly electrocatalytically active graphene-based materials, as well as the characterization and testing of the electrochemical performance of new samples in dopamine detection.

This research presents modified Hummers' methods, including the pre-oxidation of graphite powder by mixtures of H₃BO₃/H₂SO₄/CrO₃ [3]. The obtained pre-oxidized graphite was subjected to oxidation by the Hummers' method using NaNO₃, H₂SO₄, and KMnO₄ [4]. Compared to the traditional Hummers' method, these substantial improvements greatly enhanced the number of oxygen functionalities onto graphene oxide (GO) layers. The thermally reduced graphene oxide (rGO) samples were produced from GO using a thermal shock method. The dried GO powders with malonic acid and P₂O₅ additives were quickly inserted into a preheated tubular furnace at a temperature of about 800 °C in Ar atmosphere. The obtained materials were characterized by XPS and Raman spectroscopy. Electrochemical measurements, in particular, cyclic voltammetry and differential pulse voltammetry, were used to evaluate the obtained samples sensitivity toward DA detection.

The results demonstrated that the thermal treatment of GO in the presence of malonic acid and P₂O₅ mixture led to effective incorporation of P element into the graphene-based material structure. Raman analysis revealed a slightly higher structural disorder in rGO layers synthesized using modified Hummers' method than in the rGO structure, derived from GO prepared by the traditional Hummers' method. Further, rGO samples were tested as label-free dopamine sensors electrodes. The electrochemical investigations showed that the samples were prospective on dopamine sensing. rGO derived from new synthesized GO using H₂SO₄/H₃BO₃/CrO₃ mixture provides a unique opportunity for future work in this area due to its relatively high sensitivity 28.64 μA·μM⁻¹·cm⁻².

Acknowledgements. This project has received funding from European Social Fund (project No 09.3.3-LMT-K-712-19-0050) under grant agreement with the Research Council of Lithuania (LMTLT).

References

1. N. S. Anuar, W. J. Basirun, M. Shalauddinab, S. Akhtera. RSC Adv. **10** (2020) 17336.
2. M.O. Klein, D.S. Battagello, A.R. Cardoso, et al. Cell. Mol. Neurobiol. **39** (2019) 31–59.
3. J. Gaidukevic, R. Aukstakojsyte, T. Navickas, R. Pauliukaite, J. Barkauskas. Appl. Surf. Sci. **567** (2021) 150883.
4. W. S. Hummers, R. E. Offeman. J. Am. Chem. Soc. **80** (1958) 1339.

EVALUATION OF ACTIVITY OF DIFFERENT COBALT COATINGS FOR HYDROGEN EVOLUTION REACTION

Z. Sukackienė*, A. Balčiūnaitė, R. Šakickaitė, L. Tamašauskaitė-Tamašiūnaitė, E. Norkus

Department of Catalysis, Center for Physical Sciences and Technology, Vilnius, Lithuania

** zita.sukackiene@ftmc.lt*

This work investigates the activity of different cobalt (Co) coatings for hydrogen evolution reaction (HER). The CoFe, CoNi, CoZn, CoFeMn, and CoFeMo coatings were deposited on a copper (Cu) surface using morpholine borane as a reducing agent. The optimal conditions for the deposition of different cobalt coatings were determined. Scanning electron microscopy images and the elemental composition of the formed composites were obtained. The electrocatalytic properties of the prepared catalysts for HER were investigated by recording linear scan voltammograms in a 1 M KOH solution at a potential scan rate of 5 mV s⁻¹ in a potential range from open-circuit potential (OCP) up to -1.5 V vs. Ag/AgCl/KCl_{sat} at a temperature of 25 up to 75 °C. The all formed composites are catalytically active for the HER. Notably, the highest catalytic hydrogen evolution performance with a Tafel slope of 299 mV dec⁻¹ was obtained using the Co₈₇Fe₈Mo₅ catalyst.

Rotating ring-disc electrode study of Manganese and Vanadium based material operation and degradation as aqueous Na-ion battery cathodes

Davit Tediashvili,^{1,2} Linas Vilčiauskas²

¹ Institute of Chemistry, Faculty of Chemistry and Geosciences, Vilnius University, Lithuania

² Center for Physical Sciences and Technology, Sauletekio al. 3, LT-10257 Vilnius, Lithuania

Davit.Tediashvili@fmc.lt

Rechargeable Li-ion batteries, offering high power and energy densities, are widely used as energy storage devices, especially for mobile applications. However, for large-scale stationary storage where the energy and power densities are of less concern, aqueous Na-ion batteries are deemed as a potential alternative. They offer attractive properties, such as safety (aqueous vs organic electrolytes) and price (Na vs Li as a charge carrier). [1] However, stable, high voltage electrode materials remain a bottleneck to fully utilizing and deploying this technology.

With a general formula of $\text{Na}_3\text{M}_2(\text{PO}_4)_3$, NASICON-structured materials are exceptional due to their unique framework structure providing fast Na-ion transport. They also offer high theoretical capacity and operating voltage, however, might suffer from poor cycling performance especially in aqueous electrolytes. [2] $\text{Na}_3\text{MnTi}(\text{PO}_4)_3$ (NMTP) reported by Goodenough et al. [3] and $\text{Na}_3\text{V}_2(\text{PO}_4)_2\text{F}_3$ (NVPF) offer high operating voltage, capacity, and stability in organic and water-in-salt electrolytes respectively. However, capacity fade is rapid in standard aqueous electrolytes.

Here we present a rotating ring-disc electrode (RRDE) study of NMTP & NVPF operation and degradation in an aqueous electrolyte solution. A similar study was performed on LiMn_2O_4 spinel electrodes in organic media, showing that degradation occurs either in fully charged or fully discharged states. [4] Our results indicate that in an aqueous media only one (Mn(III)/Mn(II)) redox pair is active, effectively halving the capacity and that dissolution occurs during a discharge only (~ 0.7 V vs Ag/AgCl). While for NVPF, degradation starts at the oxidation of V³⁺ and reaches peak during the full charge of the material

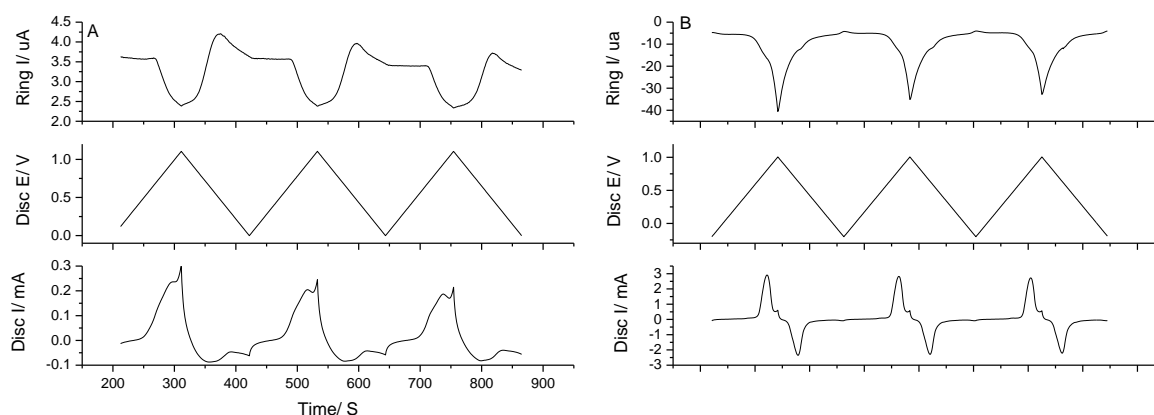

Figure 1. Applied potential on the disc and resulted current on the disc and ring for NMTP (A) and NVPF (B) during RRDE experiment

Acknowledgments:

This project has received funding from the European Regional Development Fund (Project No. 01.2.2-LMT-K-718-02-0005) under a grant agreement with the Research Council of Lithuania (LMTLT)

- [1] L. Suo et al., "Water-in-salt" electrolyte enables high-voltage aqueous lithium-ion chemistries, *Science* **350**, 938-943 (2015).
- [2] D. Bin et al., Progress in Aqueous Rechargeable Sodium-Ion Batteries, *Advanced Energy Materials* **8** (17), 1-31 (2018).
- [3] H. Gao et al., Sodium extraction from NASICON-structured $\text{Na}_3\text{MnTi}(\text{PO}_4)_3$ through Mn(III)/Mn(II) and Mn(IV)/Mn(III) redox couples. *Chemistry of Materials* **28** (18), 6553-6559 (2016)
- [3] L Wang et al., Study of Mn Dissolution from LiMn_2O_4 Spinel Electrodes Using Rotating Ring-Disk Collection Experiments, *Journal of Electrochemical Society*, **150** (7), 905-911 (2003).

N-Doped Wood-Derived Carbon Material Supported with Gold Nanoparticles as an Efficient Catalyst for Glucose Electro-Oxidation

Daina Upskuvienė¹, Aldona Balčiūnaitė¹, Jūratė Vaičiūnienė¹, Ivar Kruusenberg², Aleksandrs Volperts³, Galina Dobele³, Aivars Zurins³, Loreta Tamašauskaitė-Tamašiūnaitė¹, Eugenijus Norkus¹

¹*Department of Catalysis, Center for Physical Sciences and Technology, Saulėtekio Ave. 3, LT-10257, Vilnius, Lithuania*

²*National Institute of Chemical Physics and Biophysics, Akadeemias Tē 23, 12618, Tallinn, Estonia*

³*Latvian State Institute of Wood Chemistry, Dzerbenes Street 27, Riga LV-1006, Latvia
Saulėtekio Ave. 3, LT-10257, Vilnius, Lithuania*

e-mail.: daina.upskuviene@ftmc.lt

This study is focused on the preparation of gold nanoparticles (AuNPs) supported carbon (C) and nitrogen-doped activated carbon (N-doped C) nanocomposites and their application for the electro-oxidation of glucose and oxygen electro-reduction. The AuNPs/N-doped C nanocomposite was prepared by two-step process. At first, activated wood-based carbon was prepared from alder charcoal and doped with nitrogen by pyrolysing samples at a temperature of 800 °C in the presence of dicyandiamide (DCDA). Further, the AuNPs were deposited on the obtained N-doped activated carbon material or carbon using glucose and ascorbic acid as reducing agents. The prepared nanocomposites were characterized by scanning electron microscopy (SEM), energy-dispersive spectroscopy (EDS), X-ray powder diffraction (XRD), Raman and X-ray photoelectron spectroscopy (XPS). The electrocatalytic activity of the nanocomposites for oxygen electro-reduction and glucose electro-oxidation was investigated using the cyclic voltammetry and rotating disk electrode (RDE) methods.

It has been determined that the AuNPs/N-doped C and AuNPs/C nanocomposites had a higher catalytic activity for the electro-oxidation of glucose than the pure Au or carbon and N-doped carbon alone, indicating the synergistic effect of AuNPs and N-doped carbon or carbon. Moreover, the highest activity shows the AuNPs supported N-doped carbon as compared with that of AuNPs supported carbon.

NANOGRAVIMETRIC AND PHOTOELECTROCHEMICAL STUDY OF SILICON PASSIVATED BY ULTRATHIN HAFNIUM OXIDE LAYER

E. Juzeliūnas*, P. Kalinauskas, L. Staišiūnas, A. Grigucevičienė, K. Leinartas, A. Selskis

Centre for Physical Sciences and Technology, Saulėtekio av. 3, LT-10257 Vilnius, Lithuania

*e-mail: emutis.juzeliunas@ftmc.lt

Hafnium oxide due to its good optical transparency, wide band gap, photoluminescence, high dielectric constant, considerable chemical stability is widely applied in various fields: capacitors, switching memories, field effect transistors, heat mirrors, biomedical sensors, corrosion protective systems for microelectronics and active metals [1-4]. Recently ultrathin HfO₂ layers were studied as promising material to enhance efficiency and stability of organic solar cells. However, a photoelectrochemical (PEC) properties of Si-HfO₂ system are known insufficiently. This study is focused on PEC behavior of p-Si with ultrathin ALD HfO₂ layers in acid perchlorate solution. The quartz crystal nanobalance (QCN) and PEC measurements (illumination: $\lambda = 505 \text{ nm}$ and $N = 50 \text{ mW cm}^{-2}$) at open circuit were used to assess the dynamics of the electrode mass and photocharging in real time.

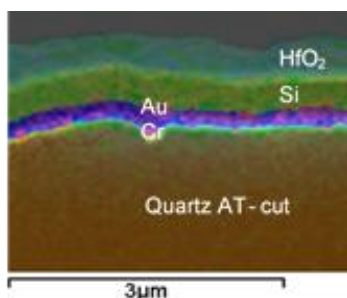

Fig. 1. Cross-section SEM image of the QCN sensor is composed of Cr/Au/Si/HfO₂ layers on quartz

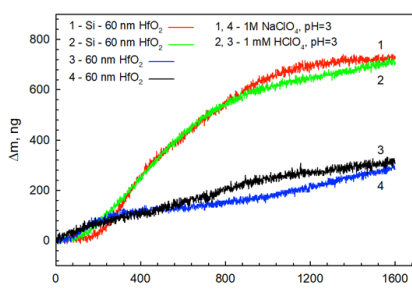

Fig. 2. QCN mass changes of the samples with 60 nm HfO₂ layer on Si (1,2) on Au (3,4) substrates in 1 mM HClO₄ and 1 M NaClO₄

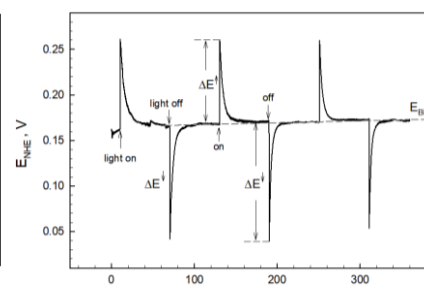

Fig. 3. Photo-potential variation at open circuit of p-Si coated with 60 nm HfO₂ in 1 M NaClO₄ (pH 3) when illumination is chopped at 1 min intervals

The QCN measurements with HfO₂ film on Si and Au substrates indicated electrolyte intake rate into the oxide film. The differences in a mass variation of Au and Si based samples were attributed to different electrochemical potentials of the substrates. No indications of HfO₂ dissolution were observed. The mass gain effect did not depend on perchlorate concentration. The photo-potential variations of p-Si coated with 10 nm and 60 nm HfO₂ layers showed nearly ideal polarizability; no Faradaic process was induced during the illumination at open circuit. The HfO₂ films also exhibited a high passivation degree of electron transfer to the solution, which was evident from inhibition of the cathodic photocurrents of hydrogen reduction.

Acknowledgement. The research received funding from the Lithuanian Scientific Council under project agreement 1200-PL479

References

- Hong Yu (Ed.), Hafnium: chemical characteristics, production and applications, South University of Science, Technology of China, Shenzhen, 2014.
- Fohlerova Z, Mozalev A, Anodic formation and biomedical properties of hafnium-oxide nanofilms, *J Mater Chem. B*, 7 (2019) 2300-2310; doi.org/10.1039/C8TB03180K.
- Li M, Jin Z, Zhang W, Bai Y, Cao Y, Li W, Wu D, Li A (2019) Comparison of chemical stability and corrosion resistance of group IV metal oxide films formed by thermal and plasma-enhanced atomic layer deposition. *Sci. Rep.*, 9:10438 (2019); doi.org/10.1038/s41598-019-47049-z.
- Staišiūnas L, Leinartas K, Juzeliūnas E, Bučinskienė D, Grigucevičienė A, Kalinauskas P, Selskis A, Stanionytė S, Anticorrosion performance of hafnium oxide ultrathin films on AZ31 magnesium alloy. *Surf Coat Technol.*, 397 (2020) 126046; doi.org/10.1016/j.surfcoat.2020.126046.

ELECTRODEPOSITION OF TERNARY Cr-CeO₂/La₂O₃ NANO-COMPOSITE FROM ENVIRONMENTALLY FRIENDLY Cr(III) BATH AND THEIR PROPERTIES

Gedvidas Bikulčius, Asta Češūnienė, Aušra Selskienė, Tadas Matijošius, Vidas Pakštas, Dalia Bučinskienė

Department of Electrochemical Material Science, Center for Physical Sciences and Technology Saulėtekio av. 3, LT-10257 Vilnius, Lithuania

One of the possible methods of to improvement of properties of thin Cr coatings is the formation of nano-composites. Various nanoparticles (Al₂O₃, TiO₂, ZrO₂, SiC, WC, B₄C, AlN, WS₂, MoS₂, CeO₂, etc.) are used for this purpose. Lanthanoids have been of great interest because they make it possible to enhance functional physical and mechanical properties of materials.

For the first time the Cr-CeO₂/La₂O₃ composite has been electrochemically deposited in a sulfate Cr (III) bath with an oxalate complexing agent. The XRD analysis revealed that incorporation of CeO₂/La₂O₃ particles into the Cr matrix does not change its state and Cr matrix remains fine-crystalline (crystallites size < 1nm). The cross-section SEM and EDS analysis confirmed incorporation of CeO₂/La₂O₃ particles (about 13 wt. %) into the Cr matrix. The studies of the mechanical properties of the Cr-CeO₂/La₂O₃ composite have shown that the hardness of the composite increases due to CeO₂/La₂O₃ particles incorporation, while both the friction coefficient and wear rate decrease. The mechanism of CeO₂/La₂O₃ nanoparticles incorporation into the Cr matrix has been discussed.

3D STRUCTURES COPPER-NICKEL FOAMS DECORATED WITH PLATINUM PARTICLES FOR THE ELECTROOXIDATION OF SODIUM BOROHYDRIDE

Žana Činčienė, Aldona Balčiūnaitė, Loreta Tamašauskaitė-Tamašiūnaitė, Jūratė Vaičiūnienė, Eugenijus Norkus

Department of Catalysis, Center for Physical Sciences and Technology, Sauletekio Ave. 3, LT-10257, Vilnius, Lithuania
zana.cinciene@ftmc.lt

Currently, one of the renewable energy sources is fuel cells, namely chemical energy is directly converted into electricity. Designing new or enhancing the existing fuel cells, much attention is devoted to the search of new effective catalysts, which would allow increasing the effectiveness of fuel cells and creating the background for designing new technologies for catalysts formation. Everyone knows that precious metal and their alloys effectively catalyze the oxidation reaction of sodium borohydride. The cost of using such catalysts alone is very expensive, so an alternative is being sought.

The aim of the work is to form efficient and inexpensive nanostructured catalysts by electroplating 3D metal copper-nickel (Cu-Ni) foams with further their decorating with small amounts of platinum nanoparticles (PtNPs) for the electrooxidation of sodium borohydride (NaBH₄). Cu-Ni foam was prepared by electrochemical deposition ($I_{\text{deposition}}=1.5 \text{ A cm}^{-2}$, $t_{\text{deposition}}= 3,6$ and 9 min) on titanium (Ti) surface. The electrolyte was containing 0.5 M Ni²⁺ ions and 0.01 M Cu²⁺ ions.

PtNPs were deposited by galvanic displacement on Cu-Ni foam (noted Pt (Cu-Ni)/Ti) by its immersion into the 1 mM H₂PtCl₆ solution at 25 °C for 1 min. The morphology and composition of the prepared catalysts were investigated using scanning electron microscopy (SEM), X-ray diffraction (XRD), and inductively coupled plasma optical emission spectroscopy (ICP-OES). The electrocatalytic activity of the prepared catalysts was evaluated towards the electrooxidation of sodium borohydride using the cyclic voltammetry method. The cyclic voltammograms were recorded on the prepared Cu-Ni foams and Pt(Cu-Ni)/Ti catalysts in a 0.05 M NaBH₄ solution in an alkaline medium in the potential range from -1.2 to 0.6 V (vs. Ag/AgCl) and with an electrode potential scan rate of 10 mVs⁻¹.

The study showed that the prepared 3D metal Cu-Ni foam and Pt(Cu-Ni)/Ti have good electrochemical stability in an alkaline NaBH₄ solution. It was also observed that immersion of Cu-Ni foam in a platinum-containing solution for 1 min increased the electrocatalytic activity of the prepared Pt(Cu-Ni)/Ti catalyst for NaBH₄ oxidation compared to Cu-Ni foam.

Acknowledgments. This research is funded by the European Social Fund under Measure No. 09.3.3-LMT-K-712-19-0138 'Development of Competences of Scientists, other Researchers and Students through Practical Re-search Activities'.

LEAD ELECTRODEPOSITION ON GRAPHITE FELT IN A REVERSABLE FLOW-THROUGH REACTOR

Arminas Ilginis^{1*}, Egidijus Griškonis¹

¹ *Physical and Inorganic Chemistry, Kaunas University of Technology, Kaunas, Lithuania*

* *arminas.ilginis@ktu.lt*

Reducing lead-acid battery (LAB) weight is one of the ways to increase the energy and power density of this battery technology. One of the ways this can be achieved is by replacing heavy lead grids, which do not participate in the electrochemical reactions with lightweight, conductive, chemically inert materials such as graphite felt (GF) [1]. However, large surface area of carbon materials in composite electrodes can lead to greater gas evolution at charging and faster self-discharge of LAB [2]. This can be mitigated by electrodepositing lead on carbon substrates and thus reducing the surface area of carbon [3].

Electrodeposition was performed in a flow-through reactor with one GF cathode (2.5 mm thickness) in the middle surrounded with two soluble lead anodes. Each electrode had a geometric surface area of 20 cm². Electrolyte consisted of 0.5 M lead(II) methanesulfonate, 0.5 M methanesulfonic acid, and 1 g L⁻¹ sodium ligninsulfonate as surfactant. A peristaltic pump was used to circulate the electrolyte at 120 mL min⁻¹ with the reversion of flow direction every 5 minutes. In some experiments, pulsating current was applied with a 1 second on period followed by 1 second rest. Total electrodeposition time was 1 hour when 15 mA cm⁻² current density was used and 30 minutes when 30 mA cm⁻² was used. After electrodeposition, the modified GF samples were washed with excess of distilled water and dried under constant 2 L min⁻¹ flow rate of nitrogen gas at 60 °C for 2 hours.

Table 1. Electrodeposition result summary

No.	Mass increase, g g ⁻¹ GF	Current efficiency, %	Electrolyte flow	Current impulse	Cathodic current density, mA cm ⁻²
1	1.62	86.5	→*	No	15
2	1.77	94.8	↔**	No	15
3	1.59	84.8	↔	Yes	15
4	1.80	96.1	↔	No	30
5	1.72	91.7	↔	Yes	30

* - one-direction; ** - periodically reversed

The results provided in Table 1 shows that electrodeposition at continuous current and when the flow of electrolyte in the reactor was not reversed periodically, the current efficiency of electrodeposited Pb was significantly lower compared to the efficiency that was achieved when the electrolyte flow was reversed periodically every 5 minutes. Furthermore, when pulsing current were used the current efficiency of Pb decreased considerably even lower than when the flow was not reversed. This indicating that dissolution of the deposited Pb was occurring while the current impulse was on the rest stage. Doubling the cathodic current density to 30 mA cm⁻² lead to an increased current efficiency in both continuous and pulsed current experiments.

References

1. J. Xiang, P. Ding, H. Zhang, X. Wu, J. Chen, Y. Yang. *J. Power Sources* **241** (2013) 150–158.
2. D. G. Enos, S. R. Ferreira, H. M. Barkholtz, W. Baca, S. Fenstermacher. *J. Electrochem. Soc.* **164** (2017).
3. A. Czerwiński, J. Wróbel, J. Lach, K. Wróbel, P. Podsadni. *J. Solid State Electrochem.* **22** (2018) 2703–2714.

SYNTHESIS OF CARBON-SUPPORTED MANGANESE (IV) OXIDE NANOCOMPOSITES FOR SUPERCAPACITORS APPLICATION

Jolita Jablonskienė*, Dijana Šimkūnaitė, Jūratė Vaičiūnienė, Giedrius Stalnionis, Audrius Drabavičius, Vitalija Jasulaitienė, Vidas Pakštas, Loreta Tamašauskaitė-Tamašiūnaitė and Eugenijus Norkus

Center for Physical Sciences and Technology, Sauletekio Ave. 3, LT-10257 Vilnius, Lithuania

** jolita.jablonskiene@fmf.lt*

In this study, the carbon-supported MnO₂ nanocomposites have been prepared using the microwave-assisted heating method followed by two different approaches. The MnO₂/C nanocomposite, labeled as sample S1, was prepared directly by the microwave-assisted synthesis of mixed KMnO₄ and carbon powder components. Meanwhile, the other MnO₂/C nanocomposite sample labeled as S2 was prepared indirectly via a two-step procedure which involves the microwave-assisted synthesis of mixed the KMnO₄ and MnSO₄ components to generate MnO₂ and subsequent secondary microwave heating of synthesized MnO₂ species coupled with graphite powder. Field-emission scanning electron microscopy (FE-SEM), transmission electron microscopy (TEM), X-ray photoelectron spectroscopy (XPS), X-ray diffraction (XRD) and inductively coupled plasma optical emission spectroscopy (ICP-OES) has been used for characterization of MnO₂/C nanocomposites morphology, structure, and composition. The electrochemical performance of nanocomposites has been investigated using cyclic voltammetry and galvanostatic charge/discharge measurements in a 1 M Na₂SO₄ solution. The MnO₂/C nanocomposite, prepared indirectly via a two-step procedure display substantially enhanced electrochemical characteristics. The high specific capacitance of 980.7 F g⁻¹ has been achieved from cyclic voltammetry measurements, whereas specific capacitance of 949.3 F g⁻¹ at 1 A g⁻¹ has been obtained from galvanostatic charge/discharge test for sample S2. Besides, the specific capacitance retention was 93% after 100 cycles at 20 A g⁻¹, indicating good electrochemical stability.

Reference

1. J. Jablonskienė, D. Šimkūnaitė, J. Vaičiūnienė, G. Stalnionis, A. Drabavičius, V. Jasulaitienė, V. Pakštas, L. Tamašauskaitė - Tamašiūnaitė, E. Norkus. "Synthesis of Carbon-Supported MnO₂ Nanocomposites for Supercapacitors Application". *Crystals* **11** (7) (2021) 784.

AuCeO₂/C – ENHANCED ELECTROCATALYTIC ACTIVITY FOR OXIDATION OF BOROHYDRIDE AND REDUCTION OF OXYGEN

V. Kepenienė, R. Stagnaitis, A. Balčiūnaitė, A. Drabavičius, V. Pakštas, V. Jasulaitienė, L. Tamašauskaitė-Tamašiūnaitė, E. Norkus

*Department of Catalysis, Center for Physical Sciences and Technology, Vilnius, Lithuania
virginija.kepeniene@ftmc.lt*

Conventional combustion-based technologies with high emission rates pose a significant threat regarding air pollution, health, and the climate. Their operation requires enormous natural resources that are not eternal. Therefore, the demand for alternative energy sources has mobilized scientists around the world to search for and research such energy sources. One of them is fuel cells, which can operate at higher efficiencies than combustion engines and can convert the chemical energy in the fuel to electrical energy with efficiencies of up to 60%; it is notable that fuel cells have lower emissions than combustion engines [1]. Different kinds of fuel cells such as direct alcohol fuel cells (DAFC), alkali fuel cells (AFC), direct borohydride fuel cells (DBFC), Proton Exchange Membrane fuel cells (PEMFC), Solid Oxide fuel cells (SOFC), and others have been investigated intensely within the past few decades. All of them have their advantages and disadvantages however the principle of their operation is similar - fuel oxidation on the anode side and oxygen reduction on the cathode side. Lately, the most attention has attracted DAFC, DBFC, PEMFC because the materials used in these fuel cells can be more easily produced, stored, and transported compared to the other fuel cells, making them more advantageous. DBFC has attracted the attention of researchers because of sodium borohydride (sodium borohydride anion BH₄⁻) potential to generate extremely pure hydrogen on demand or just be directly oxidized in a DBFC. Moreover, the BH₄⁻ has higher volumetric (7314 Whdm⁻³) and gravimetric (7100 Whkg⁻¹) energy density than methanol (4800 Whdm⁻³) and (6000 Whkg⁻¹), respectively [2]. BH₄⁻ is also more stable in an alkaline medium (pH > 14) [3]. Additionally, an alkaline BH₄⁻ solution is easy and safe to transport and the final product BO₂⁻ anion (boric acid) of BH₄⁻ oxidation (BOR) is environmentally safe, relatively inert, and non-toxic. The oxygen reduction reaction (ORR) kinetics is facile under alkaline conditions. In the light of these advantages, DBFC technology is still attractive for investigation regarding its use as a potential power generator technology in energy systems [4].

This study presents electrocatalytic activity of the AuCeO₂/C and Au/C catalysts, prepared using microwave irradiation, toward sodium borohydride oxidation and oxygen reduction reactions in an alkaline medium. It has been found that the obtained AuCeO₂/C having Au loading and electrochemically active surface area of AuNPs equal to 71 μg cm⁻² and 0.05 cm², respectively, showed enhanced electrocatalytic activity toward investigated reactions compared with the Au/C catalyst having Au loading and electrochemically active surface area of AuNPs equal to 78 μg cm⁻² and 0.19 cm², respectively. The AuCeO₂/C catalyst demonstrated 4.5 times higher current density values for sodium borohydride oxidation compare with those at the bare Au/C catalyst. Moreover the onset potential of oxygen reduction reaction (0.96 V) on the AuCeO₂/C catalyst was very similar to commercial Pt/C (0.98 V).

References

1. Fuel Cells. Available online: <https://www.energy.gov/eere/fuelcells/fuel-cells>.
2. X. Li, X. Qin, B. Yan, H. Huang, W. Zhang, Y. Piao. *Catalysts* **10** (2020) 1440.
3. M. V. Mirkin, H. Yang, A. J. Bard. *J. Electrochem. Soc.* **139** (1992) 2212.
4. D. M. F. Santos, C. A. C. Sequeira. *Electrochim. Acta* **55** (2010) 6775.

PROTECTIVE AND SELF-HEALING PROPERTIES OF CERIUM-MODIFIED MOLYBDATE CONVERSION COATING ON STEEL

Aliona Kirdeikiene^{1*}, Olga Girčienė¹, Laima Gudaviciūtė¹, Vitalija Jasulaitienė², Algirdas Selskis², Rimantas Ramanauskas¹

¹ *Department of Chemical Engineering and Technology, State research institute Center for Physical Sciences and Technology, Vilnius, Lithuania*

² *Department of Characterization of Materials Structure, State research institute Center for Physical Sciences and Technology, Vilnius, Lithuania*

* *aliona.kirdeikiene@ftmc.lt*

Chromate conversion coatings have been widely applied for corrosion protection of metals, as providing both, barrier and self-healing effects. Due to the legal framework restricting the use of highly toxic Cr (VI) compounds in industry, researchers are looking for alternatives. Phosphating is one of the most widely used passivation treatments of steel, however, the corrosion resistance of the resulting conversion layer is not sufficient and requires to be improved. The protective ability of phosphate coatings on steel could be improved by the passive layer modification with Mo compounds. Meanwhile, additional modification with Ce compounds support the physical barrier on the metal surface and can provide self-healing properties for the resulting coating. The research objects were phosphate/molybdate and cerium-modified phosphate/molybdate conversion coatings deposited on a carbon steel surface [1].

The aim of the present study was to evaluate the protective and self-healing capacities of the deposited conversion coatings on a steel surface and to study the process of a new passive film formation on the artificially damaged areas of these coatings. SEM, TEM, XRD and XPS techniques were applied for the structural, phase and composition characterization of the investigated coatings. Voltammetric measurements were carried out to determine the passive layer protective ability. EIS studies yielded information on the self-healing properties of different protective systems affected by introduced artificial defects.

It was established that the protective properties of the investigated conversion coatings depend on their morphology, microstructure and composition. The presence of sulphate ions in the Ce solution favored the formation of a thinner conversion layer, which had a significantly lower number of structural defects and had the best protective ability among all the investigated coatings. The phosphate/molybdate coatings were shown to be incapable of self-repair. This can be attributed to the fact that molybdates are weaker oxidizing agents than Ce-containing compounds. Among cerium-modified phosphate/molybdate coatings, the one deposited in sulphate containing solution was found to have stronger self-healing ability. This was attributed to the higher total amount of Ce, the larger fraction of Ce (IV) in the conversion coating and the lower number of structural defects. The micro-structural characteristics of protective coatings are also important in determining self-healing abilities, because in assessing active corrosion protection ability of conversion layers it is important to consider not only the ratio of higher and lower oxidation states of the active ions, but also the quantity of material required for self-healing, as this process will occur not only on defected areas, but also in the zones of cracking of the passive conversion film.

References

1. A. Kirdeikiene, O. Girčienė, L. Gudaviciūtė, V. Jasulaitienė, A. Selskis, S. Tutliene, M. Skrodiene, J. Pilipavicius, J. Juodkazyte, R. Ramanauskas. *Coatings* **194** (2021), 11.

IMPACT RESISTANCE OF ELECTROLESS Ni-P COATINGS ON ANODIZED AA6061 ALLOY

Gedvidas Bikulčius, Sigitas Jankauskas, Aušra Selskienė, Laurynas Staišiūnas, Tadas Matijošius*, Svajus Asadauskas

Department of Chemical Engineering and Technology, Center for Physical Sciences and Technology (FTMC), Vilnius, Lithuania

* tadas.matijosius@ftmc.lt

Automobile industries required Al components with good mechanical properties. NiP coatings produced by the electroless deposition increase mechanical resistance. Their durability is determined by the adhesion between NiP coating and substrate e.g. anodic Al₂O₃. Activation of Al₂O₃ layer with PdCl₂ before NiP deposition increased surface hardness and resistance against the scratching [1] while NiF₂ improved adhesion between Al₂O₃ and NiP coating [2]. Our purpose of this work is to investigate the treatment influence of Al alloy on NiP adhesion.

AA6061 alloy specimens were cleaned in alkaline solution UniClean 151 for 7 min at 55 °C, rinsed in DI water then cleaned in acid solution Alklean AC-2 for 30 s at 30 °C and rinsed again. Anodization was performed in 195 g/l H₂SO₄ with 9 g/l Al³⁺ by applying 15 V DC at 19 °C to obtain a nanoporous Al₂O₃ layer of 5 μm thickness. NiP coating was deposited with or without double zincate activation. After the first zincate treatment in solution Alumseal NCY X2 for 20 s at 20 °C, 40 wt.% HNO₃ pickling for 30 s at 20 °C, second zincate treatment and rinsing, NiP coatings were produced by electroless deposition in solution MARQUEE BMP of pH 4.7 for 40 min at 88–92 °C. Another method includes the formation of NiP coating on the Al₂O₃ without zincate activation. The specimens were rinsed and dried in air.

Qualitative evaluation of NiP adhesion on Al₂O₃ layer was carried out by impact test (ASTM D 2794). A method (U-1, Russia) with an 8 mm diameter spherical ball was used for evaluating the resistance of NiP coating to deformation caused by a falling weight. The opposite side of the impact site of NiP coating was analyzed by optical microscope at 18× magnification.

Cross-sectional studies evaluated by SEM, EDX showed that the thickness of NiP coatings reaches 10 μm with the content of P about 7.0 wt.% in both cases. The adhesion strength of NiP coating was much higher without zincate activation when compared with activation. In the case of Al₂O₃-Zn-NiP coatings, surfaces showed a lot of microcracks (Fig. 1a). Meanwhile, on Al₂O₃-NiP only visible tensions of NiP coating were visible (Fig. 1b).

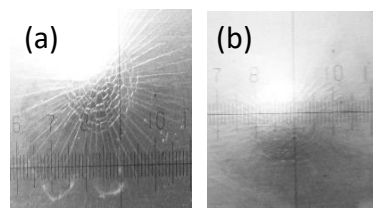

Fig. 1. Optical images after impact tests on the opposite side of anodized specimens: (a) Al₂O₃-Zn-NiP, (b) Al₂O₃-NiP at 18× magnification

Combining of Al₂O₃ layer and electroless NiP coatings led to superior impact resistance when compared to Al₂O₃ with double zincate activation.

Acknowledgments

This work was supported by the Lithuanian federal research project [grant number 01.2.2-CPVA-K-703-03-0024].

References

1. M. Sundararajan., M. Devarajan, M. Jaafar. Mater. Lett. **289** (2021) 129425.
2. M. Kocabaş, C. Örnek, M. Curioni, N. Cansever. Surf. Coat. Tech. **364** (2019) 231.

EFFECTIVENESS OF FATTY ACIDS ON WEAR RESISTANCE OF ANODIC COATINGS

Tadas Matijošius*, Gedvidas Bikulčius, Svajus Asadauskas

Department of Chemical Engineering and Technology, Center for Physical Sciences and Technology (FTMC), Vilnius, Lithuania

* tadas.matijosius@ftmc.lt

Utilization of anodized aluminum (Al) for high-tech application is increasing rapidly. Despite its hardness, wear of anodic coating remains one of the major problems. Polytetrafluoroethylene (PTFE) coatings are often used to improve the wear resistance of anodized Al. Nevertheless, the non-wetting nature and high molecular size of PTFE polymers are not favorable for penetrating into nanopores of anodic coating. As an alternative, two fatty acids (FA) were tested for friction on anodized alloys 6082 (96.7% Al) and 7075 (87.4% Al).

Technical grade oleic a. (70% pure), lauric a. (>90% pure) and fluoropolymer-based DryFilm RA/IPA dispersion of 25% solids (DuPont) were used for impregnating the anodic coatings. Anodization was performed in H₂SO₄/oxalic a. (Type III) electrolyte, producing hard Al₂O₃ coatings of 60 μm thickness [1]. The anodized specimens were immersed in heated FA for 1 hour at 90 °C, then pulled out and suspended for dripping off. For PTFE coatings, the substrates were placed into the tube furnace RS 80/500/11 (Germany) at 310 °C for 10 min curing, then taken out from the furnace and optionally rubbed with lint-free cloth for 10-15 s before cooling below 90 °C for thermo-mechanical treatment, as recommended by the manufacturer. Ball-on-Disc Tribometer Micro-PoD TR-20 M63 (Ducom) was used for friction tests. A bearing steel 100Cr6 ball of 6 mm OD and 96.5% purity was fixed into the holder and pressed under the 50 N load against the coated specimen, mounted on a rotary part. The rotational motion of 500 rpm resulted in track length of 31.4 mm for one revolution.

Effectiveness of PTFE did not improve because of thermo-mechanical treatment, Fig. 1.

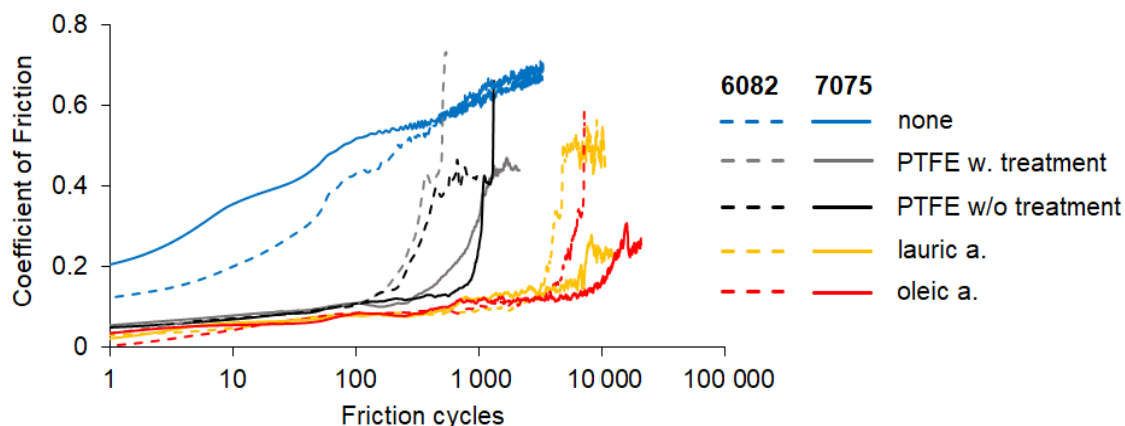

Fig. 1. Influence of PTFE and FA on friction tendencies of anodized 6082 and 7075 alloys under 50 N load

Nanopores of less than 20 nm were not large enough for PTFE to penetrate. Lauric and oleic a. appear much more effective in wear inhibition, being able to withstand nearly 10 000 friction cycles with COF ~ 0.1 under 50 N load. Finetuning of FA composition can lead even to further improvements in tribological performance.

Acknowledgments

This work was supported by the Lithuanian federal research project [grant number 01.2.2-CPVA-K-703-03-0024].

References

1. T. Matijošius, A. Pivoriūnas, A. Čebatariūnienė, V. Tunaitis, L. Staišiūnas, G. Stalnionis, A. Ručinskienė, S.J. Asadauskas. *Ceram. Int.* **46** (2020) 15581–15593.

APPLICATION OF POLY(FOLIC ACID) FOR PH DETECTION

Vytautas Žutautas, Rasa Pauliukaitė

*Department of Nanoengineering, Center for Physical Sciences and Technology (FTMC),
Savanoriu Ave. 231, Vilnius 02300, Lithuania
vytautas.zutautas@ftmc.lt*

Many chemical processes are pH dependent and because of that its monitoring is very important. When glass electrodes for pH measurement cannot be used other methods are required. One of such methods to determinate hydrogen ions is use pH-sensitive conductive polymer modified electrodes [1].

Conducting polymers belong to polyenes or polyaromatic classes. Some have unique conduction mechanisms and are stable in air [2]. Using the electrochemical synthesis these polymers can be directly deposited as a film on electrode substrate [3]. To develop sensors, conductive polymers used most often are poly(1,5-diaminonaphthalene), terthiophene carboxylic acid, polyaniline, polypyrrole, etc. [3].

The aim of this work is to create a sensor to monitor pH in washing systems of food industry. In order to achieve this aim, chitosan drop coated pyrolytic graphite electrode was further modified with electrochemically polymerized folic acid [4]. Resulted sensor stability was tested in buffer solutions of pH 7 and 8 using cyclic voltammetry and chronoamperometry.

Acknowledgements. This work was supported by Lithuanian Research Council grant No. 01.2.2-LMT-K-718-03-0038.

References

1. S. Zaman, MH. Asif, A. Zainelabdin, G. Amin, O. Nur, M. J. Willander. *Electroanal. Chem.* **662** (2011) 421-425.
2. D. Kumar, R. C. Sharma. *Polymer J.* **34** (1998) 1053-1060.
3. MA. Rahman, P. Kumar, DS. Park, YB. Shim. *Sensors.* **8** (2008) 118-141.
4. F. Zouaoui, S. Bourouina-Bacha, M. Bourouina, N. Jaffrezic-Renault, N. Zine, A. Errachid. *Trends in Analytical Chemistry.* **130** (2020) 115982.

KINETICS OF GRAPHENE OXIDE THERMAL DECOMPOSITION IN THE PRESENCE OF CARBON SUBOXIDE

Rūta Aukštakojytė¹, Justina Gaidukevič¹, Jurgis Barkauskas¹

¹ Institute of Chemistry, Faculty of Chemistry and Geosciences, Vilnius University, Vilnius, Lithuania

* ruta.aukstakojyte@chgf.vu.lt

The thermal reduction of graphene oxide (GO) is an efficient and simple route to prepare graphene-based materials in large quantities. However, this synthesis method has several drawbacks, including a complex mechanism of GO thermal decomposition, a high release of energy, and the formation of structural defects during the process of thermal exfoliation [1, 2]. According to the literature, the thermal reduction of GO could be more precisely controlled using reducing agents, salts, organic dyes or acids [3, 4]. Carbon suboxide (C₃O₂) that forms from the reaction between malonic acid and phosphorus pentoxide is a promising additive in the thermal reduction of GO because it decomposes to elemental carbon and carbon monoxide [5]. The supplemental source of carbon could more effectively repair the disordered structure of the reduced GO that could also improve the electronic properties of the final product and ensure the successful application of reduced GO in electrochemical devices.

In this study, we present the impact of C₃O₂ on the kinetics of GO thermal reduction reaction. The GO synthesis was carried out via the modified Hummers' method [6]. Afterwards, the synthesised GO and the prepared homogenous mixture of GO, malonic acid, and phosphorus pentoxide were analysed by using thermogravimetry (TG), derivative thermogravimetry (DTG), and differential scanning calorimetry (DSC) methods at three different heating rates: 2.5 °C min⁻¹, 5 °C min⁻¹, and 10 °C min⁻¹. The kinetic (E_a , n) and thermodynamic (ΔH) parameters of the thermal decomposition reaction of GO with and without C₃O₂ were determined by using Borchardt-Daniels, Kissinger, and Ozawa models [7].

DSC results revealed that the reduction temperature of GO is reduced (up to 125 °C) by using C₃O₂. Moreover, it was observed that C₃O₂ lowers the enthalpy ΔH and activation energy E_a but does not influence the reaction order n of GO thermal decomposition. The apparent reaction order n for both studied samples was determined to be 0.7. In fact, the mechanism of this process could be modelled including consecutive zero-order and first-order stages. The zero-order process may originate when the energy consumed in the thermal decomposition reaction comes through the basal graphene plane; then, the reaction rate should not depend on the reagent concentration (i.e., the concentration of oxygen functionalities). The first-order process may occur when the energy is absorbed directly by a functional group; this time the reaction rate depends only on the concentration of the reagent. The same reaction order for GO with and without C₃O₂ reduction reveals the same mechanism for both processes.

References

1. Y. Qiu, F. Guo, R. Hurt, I. Külaots. Carbon **72** (2014) 215–223.
2. G. T. T. Le, J. Manyam, P. Opaprakasit, N. Chanlek, N. Grisdanurak, P. Sreearunothai. Diam. Relat. Mater. **89** (2018) 246–256.
3. Y. Qiu, F. Collin, R. Hurt, I. Külaots. Carbon **96** (2016) 20–28.
4. J. Barkauskas, J. Gaidukevič, G. Niaura. Carbon Lett. **1** (2021) 3.
5. M. Allen. Nature **354** (1991) 272.
6. X. Yan, J. Chen, J. Yang, Q. Xue, P. Miele. ACS Appl. Mater. Interfaces. **2** (2010) 2521–2529.
7. M. V. Alonso, M. Oliet, J.M. Pérez, F. Rodríguez, J. Echeverría. Thermochim. Acta. **419** (2004) 161–167.

SYNTHESIS OF CONTROLLED SIZE $\text{GdPO}_4 \cdot \text{H}_2\text{O}$ NANORODS

Darius Budrevičius^{1*}, Ramūnas Skaudžius¹

¹*Department of Inorganic Chemistry, Vilnius University, Naugarduko 24, LT-03225, Vilnius, Lithuania*

**E-mail: darius.budrevicius@gmail.com*

Due to the wide nanoparticles application, the synthesis of nanoparticles and the study of their properties are of great interest to scientists. Special attention is paid not only to particle size but also to their morphology. Physical properties depend on the morphology of the nanoparticles. The Eu doped GdPO_4 exhibits luminescent properties. These particles can be applicable in biomedicine, for example, in biological labels, biological images and drug delivery [1,2].

In this study Eu doped $\text{GdPO}_4 \cdot \text{H}_2\text{O}$ were prepared by hydrothermal synthesis. Our goal is to investigate the dependence of morphology and size of nanoparticles on the synthesis conditions, and synthesizing $\text{GdPO}_4 \cdot \text{H}_2\text{O}$ nanoparticles. One parameter was changed during each synthesis. The synthesis of $\text{Gd}_{0.85}\text{Eu}_{0.15}\text{PO}_4 \cdot \text{H}_2\text{O}$ had been performed by changing the solvent amount (H_2O) in reactor of hydrothermal autoclave, the amount of reagents was kept the same. The pH of the solution adjusted with adding nitric acid. Samples were analysed by X-ray diffraction and scanning electron microscopy. The luminescence properties also had been measured.

References

1. M. Janulevicius, V. Klimkevicius, A. Vanetsev, V. Plausinaitiene, S. Sakirzanovas, A. Katelnikovas. Controlled hydrothermal synthesis, morphological design and colloidal stability of $\text{GdPO}_4 \cdot n\text{H}_2\text{O}$ particles. *Materials Today Communications* Vol. 23, 2020, 100934.
2. H. Song, L. Zhou, L. Li, F. Hong, X. Luo. Hydrothermal synthesis, characterization and luminescent properties of $\text{GdPO}_4 \cdot \text{H}_2\text{O}:\text{Tb}^{3+}$ nanorods and nanobundles. *Materials Research Bulletin* Vol. 48, 2013, pp 5013–5018.

OPTICAL SPECTROSCOPY STUDIES OF NEW INORGANIC $\text{K}_2\text{Bi}_{0.8}\text{Yb}_{0.2}(\text{PO}_4)(\text{MoO}_4)$ DOPED WITH Er^{3+} PHOSPHORS

Julija Grigorjevaite^{1*}, Arturas Katelnikovas¹

¹Institute of Chemistry, Faculty of Chemistry and Geosciences, Vilnius University,
Naugarduko 24, LT-03225 Vilnius, Lithuania;

*julija.grigorjevaite@chf.vu.lt

The absorption of two or more photons leading to the emission of light at a wavelength shorter than the excitation wavelength is described as the upconversion (UC) process. UC materials possess many outstanding optical features and these materials are widely used in many devices such as solid-state lasers, temperature sensors, optical fibers or displays technologies [1].

A series of up-converting materials doped with Er^{3+} ions was synthesized by solid state reaction method. All of the synthesized materials have shown similar emission spectra. The most intense sample, under 980 nm laser excitation, was doped with 5% Er^{3+} and the main emission peaks are centered in the orange-red region. These peaks can be attributed to the $^4\text{F}_{9/2} \rightarrow ^4\text{I}_{15/2}$ transitions of Er^{3+} ions (see Fig. 1).

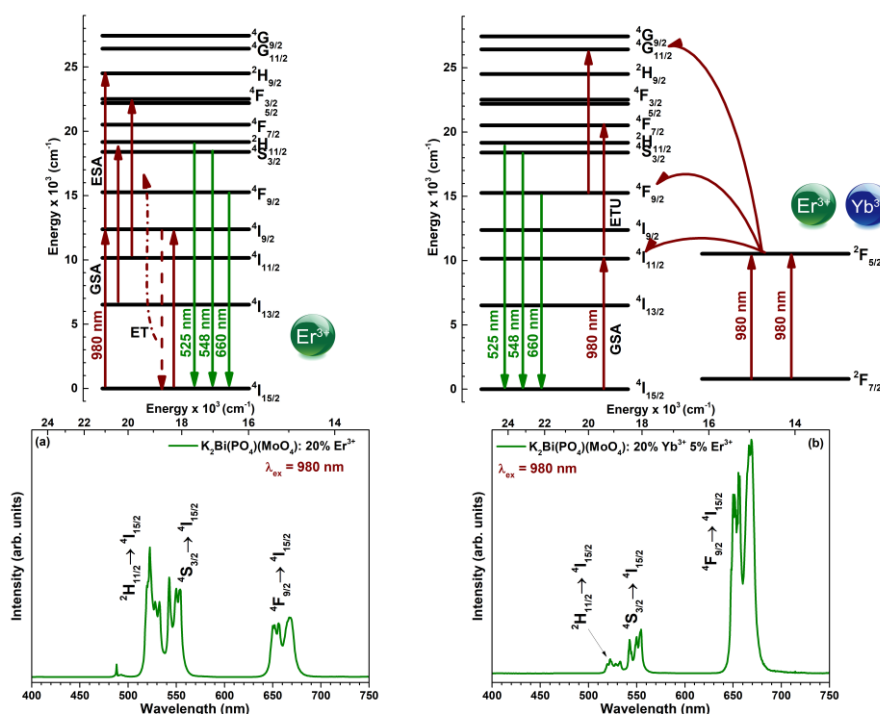

Fig. 1. Schematic energy level diagram of transitions in Er^{3+} and Yb^{3+} ions. The up-emission spectra below represent $\text{K}_2\text{Bi}(\text{PO}_4)(\text{MoO}_4)$ doped with Er^{3+} (a) and co-doped with Er^{3+} - Yb^{3+} ions (b) under 980 nm excitation.

The upconversion luminescence emission of these materials have been studied and will be particularly presented and discussed in the poster.

Acknowledgements. This research was funded by a grant (No. D-2018-0703 “Controlling the upconversion emission by tuning band gap of the host matrix”) from the Research Council of Lithuania.

References

1. A. Bayart, F. Szczepanski, J. F. Blach, J. Rousseau, A. Katelnikovas, S. Saitzek, Upconversion luminescence properties and thermal quenching mechanisms in the layered perovskite $\text{La}_{1.9}\text{Er}_{0.1}\text{Ti}_2\text{O}_7$ toward an application as optical temperature sensor, *Journal Alloys and Compounds*, 744, (2018), 516-527.

INVESTIGATION OF CERIUM AND BORON DOPED YTTRIUM AND LUTETIUM ALUMINUM GARNET CERAMICS

Greta Inkrataitė^{1*}, Ramūnas Skaudžius¹

¹ Institute of Chemistry, Faculty of Chemistry and Geosciences, Vilnius University, Naugarduko st. 24, LT-03225 Vilnius, Lithuania

* greta.inkrataite@chgf.vu.lt

In order to convert high-energy radiation, such as gamma or X-rays, into a visible light, a certain type of material is needed. Such compounds are usually referred to as scintillators. Over the years many different candidates to fit the requirements were examined. However, compounds with garnet structure have attracted a particularly large amount of attention [1]. Cerium doped yttrium and lutetium aluminum garnets (YAG:Ce, LuAG:Ce), have high density, high thermal stability, a rather intensive emission/excitation and high quantum efficiency which are needed for a good scintillator. However, further optimization and improvement is still needed especially on the shortening of the decay time. One way to approach this problem is to alloy the aforementioned compounds with different elements, such as boron and magnesium [2,3].

In this work we describe the synthesized YAG and LuAG garnets that are doped with 0.5% cerium that are additionally doped with 5% of boron and / or 0.03% of magnesium. The initial powders of garnets were synthesized Sol-Gel method. Ceramics were obtained using hydrostatic pressure. Boron and additional doping by magnesium are expected to improve required luminescent properties. Selected sol-gel method determines the homogeneity of compounds and low temperatures of synthesis. Phosphor coatings were analyzed by X-ray diffraction analysis and scanning electron microscopies. Emission, excitation spectra and decay times have been investigated as well.

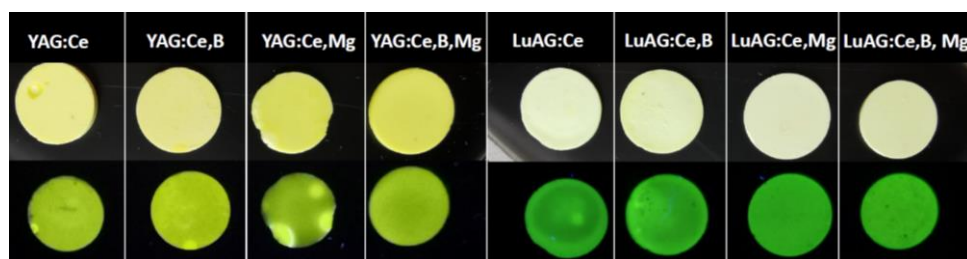

Fig. 1. Ceramics of different garnets in day light and under 365 nm excitation.

References

1. I.P. Machado, V.C. Teixeira et al. *J. Alloys Compd.* **777** (2019) 638-645.
2. C. Foster, M. Koschan et al. *J. Cryst. Growth.* **486** (2018) 126-129.
3. M.T. Lucchini, O. Buganov et al. *J. Lumin.* **194** (2018) 1-7.

SYNTHESIS OF MONOPHASIC SrAl₄O₇ COMPOUNDS DOPED WITH EUROPIUM AND DYSPROSIUM AND INVESTIGATION OF LUMINESCENT PROPERTIES

Aleksej Mackevic^{1,*}, Martynas Misevicius^{1,2}

¹*Institute of Chemistry, Faculty of Chemistry and Geosciences, Vilnius University, Naugarduko street 24, LT-03225 Vilnius, Lithuania*

²*Center for Physical Sciences and Technology, Sauletekio Av. 3, LT-10257, Vilnius, Lithuania*

*e-mail: Aleksej.mackevic@chgf.stud.vu.lt

Strontium aluminate SrAl₄O₇ structure is monoclinic with space group *C2/c* and having cell parameters $a=13.04$, $b=9.01$, $c=5.55$ and $\beta=106.502^\circ$ [1]. According to published scientific literature SrAl₄O₇ is the least researched phase compared to other strontium aluminates which is why it draws much attention nowadays. Its crystallization is sensitive to heating rate due to low kinetics of formation. Koen Van Eeckhout in his review article noted that method of synthesis is very important since crystal structure and luminescence properties of the same compound synthesized by different methods may vary. For example when synthesizing CaAl₂O₄ by sol-gel method one group got a hexagonal structure and the other group ended up with orthorhombic when monoclinic structure was expected [2].

The goal of this study was to synthesize pure phase SrAl₄O₇ via solid state reaction doped with Eu²⁺ and codoped with Dy³⁺ to get a persistent luminescence phosphor. The resulting powder materials crystal structure was analyzed with XRD. Luminescence measurements were carried out using a spectrophotometer to determine emission and excitation spectrum and to record the afterglow of the phosphor. It was noted that luminescence properties vastly vary with different dopant and codopant concentrations added and big dopant concentration may affect the crystal structure. Moreover different dopant concentrations may improve or worsen certain luminescence properties, for example high dysprosium content increases emission intensity but lowers the afterglow duration and on the other hand lower dysprosium content lowers emission intensity but increases afterglow duration, which is why it is important to investigate the optimal conditions to get a desired persistent phosphor with long afterglow and good emission intensity.

Acknowledgement. This project has received funding from European Social Fund (project No 09.3.3-LMT-K-712-19-0119) under grant agreement with the Research Council of Lithuania (LMTLT).

References

1. A.J. Lindop, D.W. Goodwin, *Acta Cryst.*, **8** (1972) 2625-2626.
2. K. Van den Eeckhout, P. F. Smet, D. Poelman, *Persistent Luminescence in Eu²⁺ Doped Compounds: A Review*, **3** (2010) 2536-2566.

INVESTIGATION OF ORTHORHOMBIC-HEXAGONAL PHASE TRANSITIONS IN HIGHLY SUBSTITUTED $\text{Lu}_{1-x}\text{Sc}_x\text{FeO}_3$ SYSTEM

Andrius Pakalniškis^{1*}, Ramūnas Skaudžius¹, Alexander Zhaludkevich², Anton Turygin³, Denis Alikin³, Dmitry Karpinsky², Aivaras Kareiva¹

¹*Institute of Chemistry, Vilnius University, Naugarduko 24, LT-03225 Vilnius, Lithuania*

²*Scientific-Practical Materials Research Centre of NAS of Belarus, 220072 Minsk, Belarus*

³*School of Natural Sciences and Mathematics, Ural Federal University, Russia*

*andrius.pakalniskis@chgf.vu.lt

Multiferroic materials are classified compounds that exhibit at least two of the primary ferroic order parameters. Over the last couple of decades, they have been widely studied due to their interesting physical properties. This is especially true for materials with both magnetic and electric orderings [1]. The ability to control magnetic ordering with electric field and vice versa opens a lot of new fields of application. However, for the most part, due to the conflicting nature of these properties, the coupling between the electrical and magnetic properties is relatively weak. Since magnetic properties usually require the 3d layer to be partially filled by electrons, while electrical properties arise from empty 3d shells [2]. To solve this conundrum, materials with new mechanism for the origin of their ferroelectric properties were discovered, such as lone pair and spin driven mechanisms, that do not require empty electron shells. The second issue that multiferroic compounds suffer from is the fact that most orderings only occur below room temperature. Only few room temperature multiferroics are known, with the main research being focused on BiFeO_3 [3].

Recently a new class of hexagonal rare earth ferrite perovskite compounds has been found to exhibit multiferroic ordering, with a mechanism and structure similar to that of hexagonal manganites, making them a new avenue for potential research [3]. However, in many cases the hexagonal ferrite compounds are relatively unstable due to their expanded lattice. Stabilization of the mentioned hexagonal structure is usually performed by thin film fabrication on some substrates, but the additional strain and interface interactions can cause substantial changes to their intrinsic physical and chemical properties [4]. As such, it is essential to analyze the bulk samples of such materials. One important candidate for further in-depth analysis is Sc doped LuFeO_3 , since via the doping effect it is possible to stabilize the hexagonal structure with a P_6cm space group [5]. However, further characterization on the exact compositional ranges and synthesis conditions on the phase formation as well as the effect of dopant on the ferroic properties still needs further research.

Hence, in this work we explore the sol-gel synthesis conditions for suitable preparation of $\text{Lu}_{1-x}\text{Sc}_x\text{FeO}_3$ in the entire concentration range ($0 < x < 1$) and investigate the structural transitions together with particle morphology and magnetic properties.

Acknowledgements. The work has been done in frame of the project TransFerr. This project has received funding from the European Union's Horizon 2020 research and innovation programme under the Marie Skłodowska-Curie grant agreement No. 778070. A.L. and A.T. acknowledge BRFFR (project #T21RM-040) and RFBR (project #20-52-04011) respectively.

References

1. K. F. Wang, J.M. Liu, and Z. F. Ren, *Adv. Phys.* **58** (2009). 321
2. Fiebig, M., Lottermoser, T., Meier, D. et al. *Nat. Rev. Mater.* **1** (2016) 16046.
3. D. Arnold *IEEE Trans. Ultrason. Ferroelectr. Freq. Control.* **62** (2015) pp. 62-82.
4. A. S. Gibbs, K. S. Knight, and P. Lightfoot, *Phys. Rev. B.* **83** (2011) 094111.
5. J. A. Moyer, R. Misra, et al. *APL Mater.* **2** (2014) 012106.

SYNTHESIS AND CHARACTERIZATION OF GRAPHITE BISULFATE

Gintarė Rimkutė^{1*}, Mantvydas Gudaitis¹, Jurgis Barkauskas¹, Justina Gaidukevič¹

¹*Faculty of Chemistry and Geosciences, Vilnius University, Vilnius, Lithuania*

**gintare.rimkute@chgf.vu.lt*

Graphite and various graphite compounds are widely used in the fields of science, technology, and industry. Particular attention is paid to graphite intercalation compounds (GICs) that are formed by the insertion of different atomic, molecular or ionic species between the layers in a graphite material [1].

These compounds exhibit excellent chemical and physical properties comparable to those of pristine graphite and are significantly relevant both theoretically and practically. They have found wide application as anode materials, heterogeneous catalysts, in production of superconductors, and in pyrophoric stabilization of reactants. Currently, GICs are also used in the preparation of graphite nanoplatelets, expandable graphite, and, most importantly, single-layer graphene [2,3].

Graphite bisulfate is a GIC with sulfate ions interposed between the graphite layers. This intercalate expands strongly when heated, which weakens the π - π interaction and then graphite layers can be easily separated. Depending on the degree of intercalation, graphite nanocrystals of different thicknesses can be obtained. To obtain a monolayer of graphene, the highest possible degree of intercalation is required, which depends on the type of oxidant and the experimental conditions [3].

The aim of this work was to investigate and compare graphite bisulfate compounds obtained by using different oxidizing agents. The synthesis of graphite bisulfate was carried out by intercalation of graphite in a mixture of H_2SO_4 and a selected oxidizer ($(NH_4)_2S_2O_8$, $K_2S_2O_8$ and CrO_3 while P_2O_5 was used as a water binding agent.

Obtained products were investigated using several methods. Raman spectroscopy was used to determine the intercalation degree and defects of the products. FTIR analysis was carried out to identify the functional groups present in GICs. SEM images were acquired to evaluate and compare the surfaces of graphite and other specimens. Optical microscope images were obtained to examine the bright colour, which is characteristic to GICs. Results will be introduced in more detail during the poster presentation.

References

1. M.S. Dresselhaus, G. Dresselhaus, Intercalation compounds of graphite, *Adv. Phys.* **51** (2002) 1–186.
2. J. Xu, Y. Dou, Z. Wei, J. Ma, Y. Deng, Y. Li, H. Liu, S. Dou, Recent Progress in Graphite Intercalation Compounds for Rechargeable Metal (Li, Na, K, Al)-Ion Batteries, *Adv. Sci.* **4** (2017).
3. M. Salvatore, G. Carotenuto, S. De Nicola, C. Camerlingo, V. Ambrogi, C. Carfagna, Synthesis and Characterization of Highly Intercalated Graphite Bisulfate, *Nanoscale Res. Lett.* **12** (2017).

INVESTIGATION OF CALCIUM (II) AND VANADIUM (V) DOPED YAG PHOSPHORS

Monika Skruodiene¹, Anatolijs Sarakovskis¹

¹ Institute of Solid State Physics, University of Latvia, 8 Kengaraga str., LV-1063 Riga, Latvia
* monika.skrudiene@cfi.lu.lv

Nowadays, research of novel garnet ceramics is focused on improvement of optical properties, such as emission intensity, quantum efficiency, decay kinetics and on their application in different areas. The optical properties could be enhanced by suppressing charge recombination during the electron transfer processes, via crystal field modulation, energy transfer or charge compensation. Charge compensation is the most commonly used method because it can be easily realized. The alkali metal ions, with low oxidation states and different ionic radius, can enhance optical properties of rare-earth ion activated phosphors by co-doping method.

Doped YAG could be a perfect lasing medium due to the properties mentioned. A lot of scientific papers have been published on the wide variety of rare-earth and other trivalent ions (e.g., Er³⁺, Ho³⁺, Tm³⁺, Yb³⁺, Cr³⁺), which can be incorporated into the YAG matrix. However, one of the current challenges and a huge interest for garnet research is how to obtain a single phase YAG when it is doped with larger quantities of divalent or pentavalent ions.

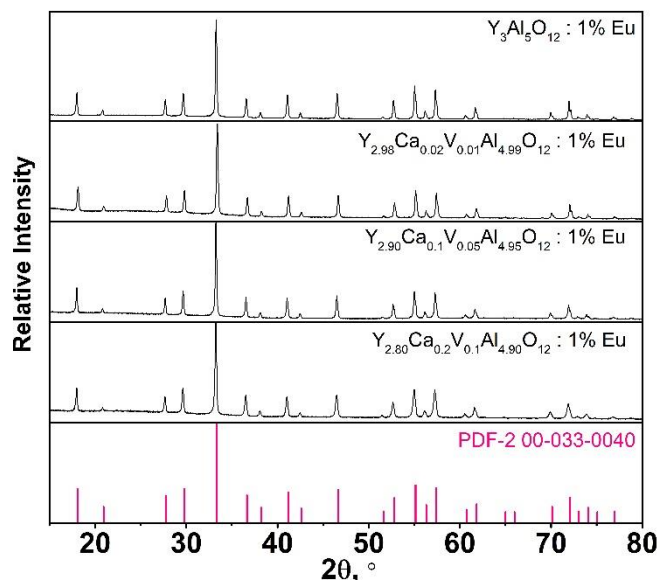

Fig. 1. XRD patterns of $Y_{3-2x}Ca_{2x}V_xAl_{5-x}O_{12}: 1\%Eu$, when $x = 0.01-0.1$, synthesized via Sol-Gel assisted Molten-Salt route, annealed at 1300 °C in KCl, in air.

Acknowledgements

The work of Monika Skruodiene is supported by ERDF PostDoc project No. 1.1.1.2/VIAA/3/19/480. Institute of Solid State Physics, University of Latvia has received funding from the European Union's Horizon 2020 Framework Programme H2020-WIDESPREAD-01-2016-2017-TeamingPhase2 under grant agreement No. 739508, project CAMART².

References

1. V. Thangadurai et al. *Journal of Solid State Chemistry* **179** (2006) 974–984.
2. J. Xue et al. *Optical Materials* **66** (2017) 220-229.
3. J. Huang et al. *Inorganic Chemistry* **50** (2011) 11487-11492.
4. S. P. Kammampata et al. *ACS Applied Energy Materials* **2** (2019) 1765-1773.
5. V. Thangadurai et al. *Journal of the American Ceramic Society* **88** (2005) 411-418.
6. V. Laguta et al. *Optical Materials* **91** (2019) 228-234.

SYNTHESIS AND CHARACTERIZATION OF $\text{La}_2\text{Mo}_2\text{O}_9$ SOLID OXIDE-ION CONDUCTOR PREPARED BY AN AQUEOUS SOL-GEL METHOD

Juras Šukys*, Giedrė Gaidamavičienė, Artūras Žalga

Department of Applied Chemistry, Institute of Chemistry, Faculty of Chemistry and Geosciences, Vilnius University, Naugarduko Str. 24, 03225 Vilnius, Lithuania
juras.sukys@chgf.stud.vu.lt

Fuel cells were discovered by William Grove in early 1839. The basic operating principle of these devices is to generate electricity and heat from hydrogen and oxygen as long as fuel and oxidant are supplied [1]. Comparing these devices with other conventional and distributed generation systems it was observed that the energy efficiency of fuel cells is always higher and pollution emissions are much lower [2]. Solid-oxide fuel cells (SOFCs) are one of the most environmentally friendly and efficient technologies to produce electric power and heat [3, 4]. Nowadays, the most widely used materials for a SOFC electrolyte are yttria-stabilized zirconia (YSZ) and gadolinium-doped ceria (GDC). However, these materials require a high-operating temperature (1000 °C) to obtain high oxide-ion conductivity. In 2000, Lacorre et al. discovered a new family of oxide ion conductors with parent compound $\text{La}_2\text{Mo}_2\text{O}_9$ [5]. Lanthanum molybdate undergoes a reversible transition from monoclinic α -phase to cubic β -phase structure at 580 °C, leading to an increase in the ionic conductivity up to two orders of magnitude and reaching values higher than those corresponding to YSZ [6].

Currently, there are various ways to synthesize LAMOX compounds, and it is known that the thermal decomposition mechanism and phase transition strongly depends on the preparation method. Lanthanum molybdate ceramic synthesized by such methods as solid-state route, citrate, a Pechini, the microwave-assisted, and EDTA complexation methods usually contain impurities, and the obtained compound has a porous structure. To eliminate these drawbacks, a lot of attention has been drawn to wet-chemical methods. The simplest, cheapest and most environmentally friendly method is an aqueous sol-gel synthesis, which creates an opportunity to control the final ceramic structure, crystallites size and morphology.

In this paper, the aqueous sol-gel synthesis was successfully used to synthesize homogenous La–Mo–O tartrate gel for $\text{La}_2\text{Mo}_2\text{O}_9$ ceramic. Tartaric acid that has two carboxylate and two hydroxyl groups, is used in this method as a complexing agent, which reduces interaction between individual components by leading to avoidance of impurities and inhomogeneity of the final ceramics. The thermal decomposition mechanism of the as-prepared La–Mo–O gel precursor was investigated by the thermogravimetric and differential scanning calorimetric (TGA/DSC) analysis. Moreover, the DCS technique was successfully applied for the measurement of enthalpy for phase transition from α -phase to β -phase in the $\text{La}_2\text{Mo}_2\text{O}_9$ system. The structure and surface morphological features of the heat-treated ceramic powders were additionally studied by X-ray diffraction (XRD) and scanning electron microscopy (SEM) analysis methods.

References

1. G. Hoogers. Fuel Cell Technology Handbook: VRV press, 2002.
2. A. Kirubakaran, S. Jains, R. Nema. *Renew. Sustain. Energy Rev.* **15** (2011) 4507.
3. A. Choundhury, H. Chandra, A. Arora. *Renew. Sustain. Energy Rev.* **20** (2013) 430.
4. N. Laosiripojana, W. Wijuratn, W. Kiatkittipong, A. Arpornwichanop, A. Soottitantawat, S. Assabumrungrat. *Eng. J.* **13** (2009) 65.
5. P. Lacorre, F. Goutenoire. *Nature*, **404** (2000) 856.
6. X. Liu, HQ Fan, Q. Li, J. Shi. *Ecs Solid State Lett.* **2(9)** (2013) N27.

LOW-TEMPERATURE SYNTHESIS OF CARBONATED HYDROXYAPATITE

Anastasija Afonina¹, Inga Grigoraviciute-Puroniene,
Aivaras Kareiva

*Institute of Chemistry, Faculty of Chemistry and Geosciences, Vilnius
University, Naugarduko st. 24, LT- 03225 Vilnius, Lithuania
anastasija.afonina@chgf.vu.lt*

Bone tissue maintains its healthy condition by constantly regenerating the affected areas, but in case of more serious lesions, the body needs help - transplantology or implantology. Calcium phosphate (CaP) based bioceramic materials have received great interest since they are widely applied for the replacement of diseased or damaged mammalian hard tissues. The inorganic part of the bone tissue consists mainly of carbonated hydroxyapatite and magnesium whitlockite (WH, $\text{Ca}_{18}\text{Mg}_2(\text{HPO}_4)_2(\text{PO}_4)_{12}$).

The main task of this work was to develop simple and low-temperature synthesis of carbonated hydroxyapatite powder. Morphological characteristics and composition of the synthesized materials were investigated by powder X-ray diffraction (XRD) analysis, Fourier transform infrared (FT-IR) spectroscopy and scanning electron microscopy (SEM).

References:

1. M. Hu et al. *Chemical Engineering Journal* **359** p. 1–12 (2019)
2. Zhou et al. *International Journal of Nanomedicine* **12** p. 2673–2687 (2017)
3. H.D. Kim et al. *Biomaterials* **112** p. 31-43 (2017)
4. Sadaf Batool et al. *Nanomaterials* **10(9)** p. 1856 (2020)
5. Chao Qi et. al *J. Mater. Chem. B* **3** p. 7775-7786 (2015)

FORMATION OF COPPER SULFIDE LAYERS ON POLYPROPYLENE BY CBD METHOD

Rasa Alaburdaitė*, Edita Paluckienė, Neringa Petrašauskienė

*Department of Physical and Inorganic Chemistry, Kaunas University of Technology,
Radvilėnų 19, LT-50254 Kaunas, Lithuania*

*[*rasa.alaburdaitė@ktu.lt](mailto:rasa.alaburdaitė@ktu.lt)*

Nanocrystalline copper sulfide (Cu_xS), deposited as a thin film on the different substrates, is considered as a promising material for solar energy conversion system, due to their structural and electrical properties. One of the interesting semiconducting layers is copper sulfide due to its metal-like electrical conductivity, chemical-sensing capability, and ideal characteristics for solar energy absorption. Consequently, polymers modified with copper sulfide layers are used as the conductive substrates for deposition of metal and semiconductors; as gas sensors functioning at temperatures tending to room temperature; in thermoelectric applications; in solar cells; in lithium ion batteries.

We have chosen polypropylene (PP) film as a cheap, chemically stable, and flexible substrate. The hydrophobic PP requires an initial surface pre-treatment and weight losses after chemical treatment are recommended to be 2 g m^{-2} . This result was reached when PP film was etched for 25 min at 90°C with oxidizing solution ($\text{H}_2\text{SO}_4/\text{H}_3\text{PO}_4$ (1:1), saturated with CrO_3).

The Cu_xS thin films deposit was carried out at room temperature by using the following procedure: 0.05 M CuCl_2 and 0.05 M $\text{Na}_2\text{S}_2\text{O}_3$ were mixed, the pH of the resultant solution was adjusted to 3. The pre-treated PP samples were immersed vertically along the wall of the reactor and were left undisturbed for deposition of Cu_xS films for 16 h at 20°C . At the end of the deposition time, the samples were taken out, and then rinsing of the substrate with distilled water for 30 s removed the desorbed ions and dried in a desiccator for 8 h. The deposition process was carried out by repeating such deposition cycles 3 times. Formed samples were annealed at 80°C for 30 min. Electrical resistivity was measured, and SEM/EDS investigation were performed after each formation cycle and after annealing of the samples.

The room temperature electrical resistivity of the formed layer after 1st deposition cycle was about $10 \text{ k}\Omega/\square$, after 2nd – $180 \Omega/\square$, and after 3rd – $130 \Omega/\square$. After annealing electrical resistivity decreased to $7 \text{ k}\Omega/\square$, $170 \Omega/\square$ and $110 \Omega/\square$ accordingly.

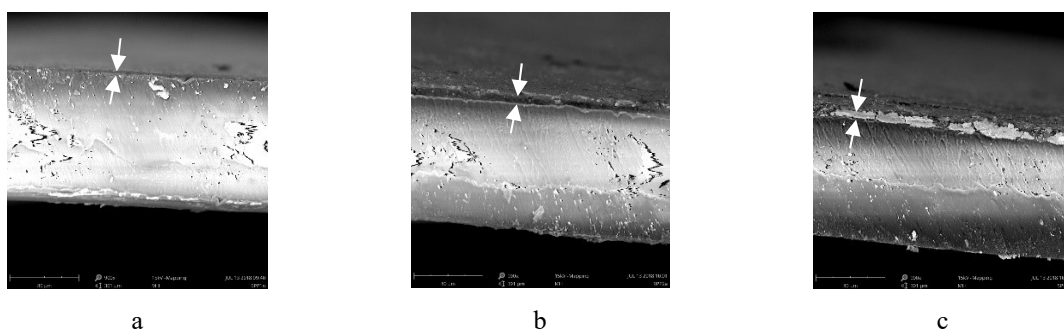

Fig. 1. Cross section of PP/ Cu_xS composite after: a) 1st deposition cycle, b) 2nd deposition cycle; c) 3rd deposition cycle

Analysis of SEM images of PP/ Cu_xS films showed that after 3 deposition cycles, the PP substrate was completely covered by Cu_xS particles. Cross sectional image (Fig. 1) demonstrated growing of Cu_xS layer with increasing of the cycle number.

WOOD – CERAMIC COMPOSITES: SYNTHESIS AND ANALYSIS OF GdPO₄·H₂O:Eu MODIFIED WOOD

Monika Baublytė^{1*}, Edita Garškaitė², Denis Sokol¹, Ramūnas Skaudžius¹

¹ Department of Inorganic Chemistry, Faculty of Chemistry, Vilnius University, Naugarduko st. 24, Vilnius,

² Wood Science and Engineering, Luleå University of Technology, Forskargatan 1, 931 87 Skellefteå, Sweden

* monika.baublyte@mb.vu.lt

Due to high sustainability, thermal and electrical insulating properties, and aesthetics, wood is the most abundant building material used in residential and non-residential buildings, furniture constructions, and decoration. Thus, high weathering, biological and pyrolytic resistance of wood is essential.

Mechanical, biological, thermal, and accelerated weathering behaviors of wood can be increased using various materials. Usually, organic compounds (phosphorus-based, phosphorus-nitrogen, phosphorus-halogen compounds) are used to impregnate the wood. Also, high resistance can be reached preparing wood – polymer composites (WPC) – polymeric agents graft onto the surface of the cell walls or cell lumen, creates a protective coating. Acetylation and in situ polymerization in wood's matrix are two major chemical modifications used to produce WPC. Nevertheless, growing awareness of the toxicity of such compounds leads to further investigation of new materials, systems, and methods that could improve wood's characteristics. Therefore, this work proposes inorganic GdPO₄·H₂O:Eu compound produced by in situ hydrothermal syntheses in wood's matrix as an alternative material increasing wood's chemical resistance.

After in situ synthesis, the characteristics of the samples were observed by scanning electron microscopy (SEM) and computed tomography (CT) (Fig.1); optical properties were determined by luminescence analysis. Thermogravimetric (TG) analysis was performed to attest the effects of GdPO₄ on the thermal degradation of wood.

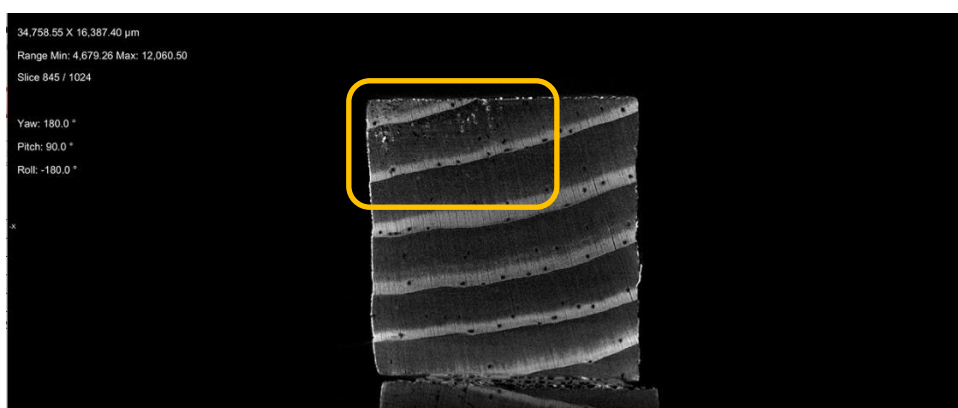

Fig. 1. Wood – ceramic composite CT

We thank prof. dr. Artūras Vailionis for a computed tomography analysis of wood – ceramic composites, and prof. dr. Algirdas Selskis for high-resolution SEM images of wood – ceramic composites.

References

1. R. Herrera, A. Arrese, P. L. de Hoyos-Martinez, J. Labidi, and R. Llano-Ponte, Evolution of thermally modified wood properties exposed to natural and artificial weathering and its potential as an element for façades systems, *Constr. Build. Mater.*, **172** (2018) 233–242.
2. Y. Wu, C. Yao, Y. Hu, S. Yang, Y. Qing, and Q. Wu, Flame retardancy and thermal degradation behavior of red gum wood treated with hydrate magnesium chloride, *J. Ind. Eng. Chem.*, **20** (2014) 3536–3542.
3. J. S. Fabiyi and A. G. McDonald, Effect of wood species on property and weathering performance of wood plastic composites, *Compos. Part Appl. Sci. Manuf.*, **41** (2010) 1434–1440.

EFFECT OF La^{3+} SUBSTITUTION ON PHYSICAL PROPERTIES OF $\text{BiFe}_{0.85}\text{Mn}_{0.15}\text{O}_3$

Ramunas Diliautas¹, Aldona Beganskiene¹, Kestutis Mazeika², Dalis Baltrunas², Dovydas Karoblis¹, Aleksej Zarkov¹, Aivaras Kareiva¹

¹ Institute of Chemistry, Vilnius University, Naugarduko 24, LT-03225 Vilnius, Lithuania

² Center for Physical Sciences and Technology, Vilnius LT-02300, Lithuania

Ramunas.diliautas@chgf.stud.vu.lt

Research in multiferroic type materials dates back to 1950s, but crucial discoveries regarding theory, characterization techniques and synthesis were found in past 15 years. Nowadays, term multiferroic are used to label materials, where ferroelectric order coexists with ferromagnetic, antiferromagnetic or ferromagnetic orders in single or multiphase materials [1]. BiFeO_3 , BiMnO_3 and RMnO_3 (where $R=\text{Tb, Y, Ho, Lu}$) are one of the few oxide type materials displaying multiferroicity. Between them BiFeO_3 has a ferroelectric Curie temperature $T_C \approx 1100$ K and an antiferromagnetic Neel temperature $T_N \approx 640$ K [2]. Impurities, like $\text{Bi}_2\text{Fe}_4\text{O}_9$ or $\text{Bi}_{25}\text{FeO}_{39}$ [3], can form when preparing this compound, which result in changes in physical properties, including magnetization. One of the ways to avoid neighboring phase formation is preparing solid solutions, having sufficient amount of BiFeO_3 .

Due to similarity in valence and ionic radii, La^{3+} can be intercalated in Bi^{3+} and Mn^{3+} can substitute Fe^{3+} . By previous studies it was observed that even small amount of La^{3+} can cause structural changes, increase in dielectric constant and reduction of Curie temperature T_C [4]. On the other hand, Mn^{3+} does not result in changes T_C or ferroelectric properties, but can cause enhancement in magnetization [5].

In this work $\text{Bi}_{1-x}\text{La}_x\text{Fe}_{0.85}\text{Mn}_{0.15}\text{O}_3$ solid solutions with different step sizes were prepared by sol-gel technique using ethylglycol as complexing agent. Two different temperatures (500 °C and 650 °C) were used for calcination of the gels. Lower temperature demonstrated possible formation of monophasic compounds up to $x=0.1$ with higher concentrations resulting in formation of impurity phases or amorphous compounds. Calcination at 650 °C temperature did not lead to formation of monophasic $\text{BiFe}_{0.85}\text{Mn}_{0.15}\text{O}_3$, but La^{3+} intercalation lead to formation of pure samples in all compositional range. All samples were characterized by X-ray diffraction, scanning electron microscopy, FT-IR spectroscopy and Mössbauer spectroscopy. Furthermore, magnetization studies were carried out for all compounds.

Acknowledgments

This work was supported by a Research grant BUNACOMP (No. SMIP-19-9) from the Research Council of Lithuania.

[1] M. Fiebig et al., The evolution of multiferroics, *Nature Reviews Materials*, **1**, 16046 (2016).

[2] J. R. Teague, R. Gerson, W. J. James, Dielectric hysteresis in single crystal BiFeO_3 , *Solid State Communications*, **8**, 1073-1074 (1970).

[3] S.M. Selbach, M. A. Einarsrud, T. Grande, On the thermodynamic stability of BiFeO_3 , *Chemistry of Materials*, **21**, 169-173 (2009).

[4] Q. Zhang et al., Effect of La^{3+} substitution on the phase transitions, microstructure and electrical properties of $\text{Bi}_{1-x}\text{La}_x\text{FeO}_3$ ceramics, *Journal of Alloys and Compounds*, **546**, 57-62 (2013).

[5] V. R. Palkar, D. C. Kundaliya, S. K. Malik, Effect of Mn substitution on magnetoelectric properties of bismuth ferrite system, *Journal of Applied Physics*, **93**, 4337 (2003).

SYNTHESIS OF GADOLINIUM ORTHOFERRITE THIN LAYERS

Justinas Januškevičius^{1*}, Ieva Čėsnaite¹, Živilė Stankevičiūtė¹, Aldona Beganskienė¹,
Aivaras Kareiva¹

¹ Faculty of Chemistry and Geosciences, Vilnius University, Vilnius, Lithuania

* justinas.januskevicius@chgf.vu.lt

The field of new magnetic material development has received a lot of attention in recent years. Research into potential multi-ferroic and spintronic materials is still picking up speed and even beginning to intersect [1]. This recent development has been driven by several factors – foremost among them the large potential for technological applications and the advancement in both the theoretical and experimental knowledge base [2–4]. Orthoferrites are a class of materials that are of potential interest in this area, with different orthoferrites showing signs of antiferromagnetic, ferrimagnetic and a whole spectrum of related magnetic properties in addition to ferroelectric properties [5]. It is a group of perovskite-like structure materials with a general formula of $R\text{FeO}_3$, where R is generally one of the rare-earth elements. The original perovskite structure is cubic, but easily deformed depending on the sizes of constituent atoms, with most orthoferrites having orthorhombic or similar structure. This formability of orthoferrites is one of their most interesting features, allowing a wide range of desired modifications to their structure and properties.

In this particular work, gadolinium orthoferrite was chosen as the synthesis target using a simple and adaptable aqueous sol-gel synthesis method. This was done to find a simple, inexpensive synthesis method and to then produce coatings on silicon substrates by using a dip-coating process. Fabrication of coatings is important for two main reasons. Firstly, thin layers can have unique properties as compared to bulk material. Secondly, many applications, especially electronics-related, require coatings of materials rather than powdered ceramics.

Initially, metal nitrates and ethylene glycol were used as starting materials for the sol-gel process [6,7]. Sol was produced, then separated into two parts – one for the production of powders, the other for dip-coating. The sol that was kept for production of powders underwent gelation, with part of the gel being used for thermogravimetric analysis. The rest of the gel was calcinated to obtain ceramic powder. After this, the rest of the sol was used to carry out a dip-coating process to obtain coatings of the orthoferrite. XRD was carried out in both cases. For the powders, it showed that the samples were not monophasic gadolinium orthoferrite, with small peaks of both constituent metal oxides visible. As for the coatings – it showed that while some desired phase formed, secondary peaks were about the same intensity or higher. Taking these results into consideration, synthesis was repeated with citric acid instead of ethylene glycol, which resulted in single phase powder, but still mixed phases for the coatings.

Acknowledgements. This work was supported by a Research grant BUNACOMP (No. S-MIP-19-9) from the Research Council of Lithuania.

References

1. H. Béa, et al. *J. Phys. Condens. Matter* **20** (2008) 434221.
2. N. A. Hill *J. Phys. Chem. B* **104** (2000) 6694–6709.
3. S. A. Wolf, et al. *Science* **294** (2001) 1488–1495.
4. S. Roy, S. B. Majumder *J. Alloy Compd.* **538** (2012) 153–159.
5. R. L. White *J. Appl. Phys.* **40** (1969) 1061–1069.
6. J. Januskevicius, et al. *Materials* **14** (2021) 1554.
7. O. Opuchovic, et al., *Chem. Eng. Commun.* **204** (2017) 1037–1048.

PREPARATION OF CuO, Co₃O₄, AND Cr₂O₃ CATALYSTS SUPPORTED BY 13X ZEOLITE

Kęstutis Čeplinskas, Andrius Jaskūnas*

*Department of Physical and Inorganic Chemistry, Kaunas University of Technology
Radvilėnų rd. 19, LT-50254 Kaunas, Lithuania*

E-mail address: andrius.jaskunas@ktu.lt

Supported catalysts utilized in oxidative abatement of volatile organic compounds (VOCs) are usually prepared by wet impregnation method, which is both cost-effective and eco-friendly [1]. Active sites are formed through the process of adsorption of thermally destructible salts on the selected support and their subsequent calcination. 13X zeolite is very durable material for catalyst preparation, because of its thermal stability, good mechanical strength and micro pore structure, which defines its adsorptive and chemical properties [2]. The best catalytic activity is achieved when the content of active component reaches 10 % so in order to optimize composition of catalysts it is necessary to evaluate adsorptive nature of support, characterize active component and evaluate its distribution after calcination.

Adsorptive properties of 13X support were determined in the series of solutions containing Cu, Co and Cr nitrates of various concentrations. Aforementioned elements and their mixtures have very wide application as active components in the preparation of catalysts. XRD analysis of dried and calcined samples showed that CuO, Co₃O₄ and Cr₂O₃ were formed as active components on the surface of zeolite. AAS analysis of solutions and calcined samples showed, that adsorptive capacity of 13X zeolite is in the range of 85.21 – 88.35 mg/g for all elements. This leads to the content of the oxides being in the range of 9.96 – 11.18 %. Adsorption isotherms were compiled and several models were used to describe peculiarities of the process – Langmuir, Freundlich, Dubinin-Radushkevich, Temkin and Elovich. All models are derived based on various premises, so each fit of the model by linear regression analysis can confirm or disprove those assumptions. Adsorption isotherms of Cu and Cr were best described by Langmuir model, which indicated that monolayer of adsorbates were formed. This was confirmed by optical microscopy, because active components were found only in the outer, up to 0.4 mm, layer of support. Egg shell type distribution of active components resulted in decrease of mechanical strength as well – up to 15 N/m² when using higher concentration impregnation solutions. Also high concentration of CuO in the outer layer of catalyst resulted in some pores being blocked together with NO_x gases failing to escape and part of nitrates remaining undecomposed. In order to maximize active surface area of catalyst and optimize distribution of the oxides, adsorption of Cu and Cr should be performed in several shorter cycles with calcination steps in between. Co adsorption was less affected by diffusion limitations and with increasing concentration of the solution it evenly covered all surface of zeolite. Adsorption modeling resulted in Freundlich isotherm being the best fit for Co, which indicates the formation of several layers of adsorbate and adsorption proceeding in several steps. Cross section of catalyst granule was evenly covered with no visible imperfections. Therefore, preparation of Co₃O₄ catalyst on the 13X support can be performed in single adsorption-calcination cycle.

References

1. P. Munnik, P. E. de Jongh, K. P. de Jong. Chem. Rev. **115** (2015) 6687.
2. A. Abdelrasoul, H. Zhang, C. Cheng, H. Doan. Micropor. Mesopor. Mat. **242** (2017) 294.

BIOCERAMIC NANO-CALCIUM HYDROXYAPATITE COATINGS ON SILICON SUBSTRATES

Rasa Karalkeviciene, Aleksej Zarkov, Greta Briedyte, Tomas Murauskas, Mantas Norkus, Aivaras Kareiva

Department of Inorganic Chemistry, Vilnius University, Vilnius, Lithuania
rasa.karalkeviciene@chgf.vu.lt

Bone is an organic-inorganic ceramic composite containing well-structured collagen fibrils, nanocrystalline, and rod-like inorganic material with length of 25–50 nm. Sequence of bone structure is formed from seven levels of hierarchy and reflects the material and mechanical properties of each component. Hydroxyapatite is chemically related to inorganic component of bone matrix as a complex structure with formula $\text{Ca}_{10}(\text{OH})_2(\text{PO}_4)_6$ [1].

Applications of this material in various industries and medicine are investigated. Hydroxyapatite synthesized by different methods has different surface morphology and the products also have different chemical properties [2].

We report the sol-gel synthesis and characterization of CHAp thin films on the silicon substrates using the spin-coating technique.

Calcium hydroxyapatite coatings on silicon substrates were formed by the synthesis of calcium carbonate (CaCO_3) by sol-gel synthesis using two solutions of different compositions: an appropriate amount of 2-propanol was mixed with acetylacetone by stirring at room temperature. Calcium nitrate tetrahydrate was added to the solution and stirred until the substance dissolved. Solution was mixed with PVA [3].

an appropriate amount of citric acid was dissolved in 20 ml of distilled water. After dissolution, the temperature was raised to 80 °C and calcium acetate monohydrate was added. After dissolving, ethylene glycol was added and stirred for about 1 hour at room temperature. Solution was mixed with PVA [4].

Silicon substrates were coated with 30 layers of each solution. Two silicon substrate coating techniques were used, which differ in the substrate screwing speed. After each coating, the silicon substrate was heated in an oven at 200 °C for 10 minutes and in an oven at 600 °C for 5 hours at a rate of 5 degrees per minute. XRD, Raman spectroscopy, SEM analysis were performed after 10, 20, 30 coatings. Silicon substrates with surface-formed amorphous and crystalline calcium carbonate (CaCO_3) were stored in disodium phosphate (Na_2HPO_4) solution for 28 days in a thermostat at 80 °C. Performed by XRD, Raman spectroscopy and SEM analysis. The results of the analysis indicate the formation of hydroxyapatite and other phosphates in the coatings.

References:

1. Zhou H, Lee J. Nanoscale hydroxyapatite particles for bone tissue engineering. *Acta Biomaterialia*. 2011;7(7):2769–2781.
2. R.Gibson. 1.3.4A - Natural and Synthetic Hydroxyapatites. *Biomaterials Science (Fourth Edition) An Introduction to Materials in Medicine* 2020, 307-317.
3. A. Zarkov, A. Stanulis, J. Sakaliuniene, Butkute, B. Abakeviciene. T. Salkus, S.Tautkus, A. F. Orliukas, S.Tamulevicius, A. Kareiva, *J Sol-Gel Sci Technol* (2015) 76:309–319.
4. P. Usinskas, Z. Stankeviciute, A. Beganskiene, A. Kareiva (2016). Sol-gel derived porous and hydrophilic calcium hydroxyapatite coating on modified titanium substrate. *Surface and Coatings Technology*, 307, 935–940.

MOLTEN SALT SYNTHESIS OF CALCIUM MANGANITE BASED COMPOUNDS

Dovydas Karoblis^{*}, Aleksej Zarkov, Aldona Beganskiene, Aivaras Kareiva

Institute of Chemistry, Vilnius University, Vilnius, Lithuania

**Dovydas.Karoblis@chgf.vu.lt*

Molten salt synthesis is a technique, which uses molten salt as a reaction medium for the preparation of different metal oxides. The large variety of inorganic salts allows achieving the products with specific morphology. This method is considered as simple, reliable, scalable, cost-effective and environmentally friendly to obtain high-purity nanoparticles with high yield. CaMnO_3 is an antiferromagnetic and paraelectric insulator with thermoelectric properties, but the preparation of single-phase material still remains a difficult task [1]. Few different techniques were employed for preparation of this perovskite, including co-precipitation [2], autocombustion [3], sol-gel [4] etc. To the best of our knowledge, there is no study regarding synthesis of CaMnO_3 by molten salt technique.

In our work, we synthesized a series of calcium manganites $\text{CaO}(\text{CaMnO}_3)_m$ ($m = 1, 2, 3$) based compounds by means of molten salt synthesis. We changed a variety of parameters (time, temperature, the different ratios between molten salt and Ca/Mn precursors) in order to obtain samples with high purity. We applied different characterization techniques, including X-Ray diffraction, FT-IR spectroscopy and scanning electron microscopy (SEM) to determine possible morphological and structural changes.

Acknowledgements. This work was supported by a Research grant BUNACOMP (No. S-MIP-19-9) from the Research Council of Lithuania.

References

1. W. Paszkowicz, et al. Powder Diffraction. **25(1)** (2010) 46-59. A. Author, B. Author. J. Am. Chem. Soc. **490** (2018) 156.
2. S. Zhao, et al. J. Mater. Sci. Mater. Electron. **26(11)** (2015) 8603-8608.
3. J. Macan, et al. Ceram. Int. **46(11)** 2020 18200-18207.
4. I.D. Fawcett, et al. Chem. Mater., **10** (1998) 3643-3651.

INFLUENCE OF GRANITE CUTTING WASTE ON THE FORMATION OF DIBASIC CALCIUM SILICATE HYDRATES

Greta Kazlauskaitė^{*}, Tadas Dambrauskas

Department of Silicate Technology, Faculty of Chemical Technology, Kaunas University of Technology,
Kaunas, Lithuania

^{*} *greta.kazlauskaitė1@ktu.edu*

High energy costs, CO₂ emissions, and limited resources are forcing the concrete industry to look for new ways to develop sustainable and environmentally friendly production. There are several ways to reduce the negative impact on nature, while the production of environmentally friendly cement by using industrial wastes is the most effective way. For example, environmentally friendly cement such as “Solidia” and “Celitement” allows to reduce the emission of carbon dioxide up to 70% in comparison to Portland cement. “Solidia” and “Celitement” can be produced by two-step synthesis: 1) hydrothermal synthesis of calcium silicates hydrates (CSH); 2) mechanochemical activation and/or thermal treatment at low temperatures (<1000 °C) of CSH. The properties of these cement depend on the mineralogical composition and properties of precursors. However, the scientific literature containing the data about the influence of industrial waste on the formation of CSH is scarce. Thus, this work aimed to determine the influence of granite cutting waste additive on the formation of calcium silicate hydrates during hydrothermal synthesis at 200 °C temperature.

For the synthesis of calcium silicate hydrates, the mixture of calcium oxide and silicon dioxide (CaO/SiO₂=1.5) was prepared. In order to determine the influence of granite cutting waste on the formation of CSH in the second mixture 5% of calcium oxide was replaced by granite cutting waste. The hydrothermal synthesis of CSH has been carried out in unstirred suspensions in an autoclave under the saturated steam pressure at 200 °C when the duration of synthesis was equal to 16 h, 48 h, and 72 h.

It was determined that α -C₂SH together with low basicity calcium silicate hydrates – xonotlite and tobermorite were formed in the pure system after 16 h of synthesis. Also, unreacted quartz and calcium carbonate, which formed due to the carbonization of synthesis products, were identified. The quantity of the latter compounds decreased by increasing the duration of synthesis to 72 h. It was established that the 5% replacement of calcium oxide by granite cutting waste strongly affects the mineralogical composition of synthesis products. The results of XRD analysis showed that at the beginning of synthesis scawtite and tobermorite were formed. Meanwhile at the end of synthesis (72 h) xonotlite, scawtite, and tobermorite were the main phases in the products.

Acknowledgment:

This research is funded by the European Social Fund under the No 09.3.3-LMT-K-712 “Development of Competences of Scientists, other Researchers and Students through Practical Research Activities” measure.

References

1. S. N. Chinnu, S. N. Minnu, A. Bahurudeen, ir R. Senthilkumar, *Construction and Building Materials*, 287 (2021) 123056
2. C. Y. Ching, M. J. K. Bashir, N. Choon Aun, ir M. A. A. Aldahdooh, *Construction and Building Materials*, 282 (2021) 122703
3. P. Stemmermann, K. Garbev, B. Gasharova, G. Beuchle, M. Haist, ir T. Divoux, *Applied Geochemistry*, 118 (2020) 104582
4. E. Gartner ir T. Sui, *Cement and Concrete Research*, 114 (2018) 27-39

CHARACTERISATION OF ZINC WHITLOCKITE SYNTHESISED UNDER HYDROTHERMAL CONDITIONS

Agne Kizalaite, Tomas Murauskas, Aleksej Zarkov

Institute of Chemistry, Vilnius University, Vilnius, Lithuania
agne.kizalaite@chgf.vu.lt

Magnesium whitlockite ($\text{Ca}_{18}\text{Mg}_2\text{H}_2(\text{PO}_4)_{14}$) is one of the major mineral components of human body constituting to approximately 20–35 wt% of human hard tissue [1]. This compound is known for its excellent biocompatibility and osteogenic capability, which makes this material a promising candidate for application in bone regeneration [2]. Incorporation of biologically active ions into the whitlockite structure could result in superior biological performance and expanded clinical application of the material. One of the potential substituents in whitlockite is Zn which can enhance the rate of metabolic processes and give antibacterial properties to calcium phosphates [3]. These properties can accelerate bone regeneration processes and decrease the infection rate.

In the present work, whitlockite powders were synthesised using hydrothermal synthesis method using calcium hydrogen phosphate dihydrate and zinc acetate dihydrate as starting materials. Synthesis was performed at 200 °C temperature for 3 h. Pure-phase whitlockite powders containing Zn ions were successfully obtained although it was demonstrated that amount of Zn in the final compound could only be varied in a very narrow range. Synthesised compounds were characterized using X-ray diffraction (XRD), inductively coupled plasma optical emission spectrometry (ICP-OES), Fourier-transform infrared spectrometry (FTIR), Raman spectroscopy and X-ray photoelectron spectroscopy (XPS).

Acknowledgement.

This was supported by a Research grant BUNACOMP (No. S-MIP-19-9) from the Research Council of Lithuania.

References

1. H. Cheng, R. Chabok et al. *Acta Biomaterialia*. **69** (2018) 342-351.
2. H. L. Jang, G. Bin Zheng et al. *Advanced Healthcare Material*. **5** (2015) 128-136.
3. I. V. Fadeeva, M. R. Gafurov et al. *BioNanoScience*. **7** (2017) 434-438.

SEM/EDS AND XRD STUDIES OF Ag-Cd-Se THIN FILMS DEPOSITED ON POLYAMIDE 6

Valentina Krylova^{1*}, Nijolė Dukštienė¹

¹ *Department of Physical and Inorganic Chemistry, Kaunas University of Technology, Radvilėnų pl. 9, LT-50254, Kaunas, Lithuania*

* *valentina.krylova@ktu.lt*

The last decade have witnessed rapid progress in the field of hybrid nanostructures toward enhanced optical and electronic properties. The cation/anion exchange reactions from pre-synthesized nanostructures is an effective strategy to diversify inorganic-organic semiconductor nanomaterials as it provides reactive capabilities in tuneable composition and property solutions [1]. Recently we have extended cation exchange reaction strategy to inorganic-organic hybrid materials synthesis [2].

In this study, we present a combined CBD-SILAR-CE method which enables us to fabricate Ag-Cd-Se thin films obtained on transparent polyamide 6 surface. The surface morphology and crystal phase structure were examined. The morphological evolution of thin films was performed using a scanning electron microscope JEOL JSM-5500LV equipped with an Energy Dispersive X-ray (EDS) microanalyzer IXRF Systems detector GRESHAM Sirius 10 with an accelerating voltage of 20 kV. The XRD analysis was performed on the Bruker Advance D8 diffractometer, operating at the tube voltage of 40 kV and tube (emission) current of 40 mA.

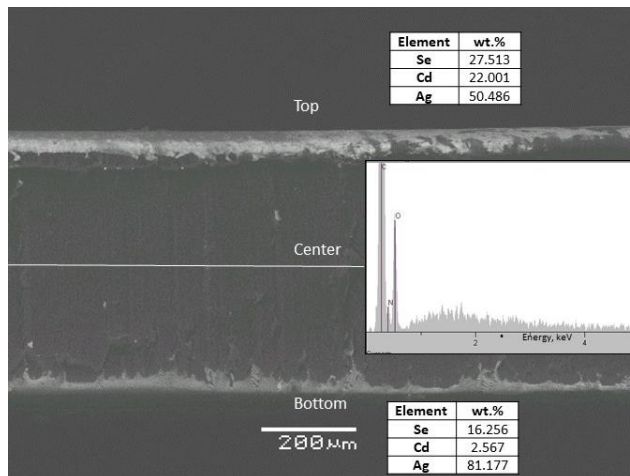

Fig. 1. SEM cross-section, EDS spectra of composite centres and elemental composition of Ag-Cd-Se thin films deposited on polyamide 6 substrate

SEM analysis confirms a very disordered morphology with a non-uniform coverage of different sized clusters. Moreover, EDS spectra analysis clarifies film of different chemical composition on the each side of polyamide (Fig 1.). These results were confirmed by XRD analysis showing a complex Se-CdSe-Ag₂Se film crystalline composition with trigonal Se (JCPDS#71-528), hexagonal CdSe (JCPDS#77-2307), orthorhombic Ag₂Se (JCPDS#24-1041) and Ag (JCPDS#24-1041) peaks.

References

1. J. Zeng, Y. Xia, U. G.D. Moon, Y. Min Jeong, *Nano Today*, **6** (2011) 186-203.
2. V. Krylova, S. Žalėnkienė, N. Dukštienė, J. Baltrusaitis, *Appl. Surf. Sci.*, **351** (2015) 203-208.

ANNOMALOUS OPTICAL PROPERTIES OF YTTRIUM ALUMINUM GARNET DOPED WITH CHROMIUM

Mantas Norkus^{1*}, Ramūnas Skaudžius¹

¹ Faculty of Chemistry and Geosciences Institute of Chemistry Vilnius University,
Naugarduko st. 24, LT-03225 Vilnius, Lithuania

* mantas.norkus@chgf.vu.lt

Yttrium aluminum garnet (YAG) with the nominal composition of $Y_3Al_5O_{12}$ is one of the most well-known oxide ceramics. Its lattice can act as a host for trivalent ions of which lanthanides are amongst the most common. Even though as by itself in recent times YAG has no substantial area of application this is changed after the addition of dopant ions. Being an optically isotropic material, it has seen huge success in research studies which were proceeded by making powders commercially viable. For example YAG:Nd, YAG:Er are being utilized as solid state lasers, optical phosphors of YAG:Ce were used in cathode ray tubes as luminescent material, as a phosphor in mercury vapor lamps or most commonly used nowadays – light emitting diodes for white light generation or scintillator materials [1-4].

Since single-crystal lasing material choices are quite limited mainly due to technological shortcomings such as the variation in melt temperature is one of the causes of inhomogeneous distribution of optically active ions, the surface of the melt also causes single-crystals to develop optical stress, striations in the end making them optically inhomogeneous. The breakthrough in ceramic lasers was achieved in 1995 with the advent of YAG:Nd polycrystalline ceramic laser, which showed equivalent or superior properties to single-crystal overcoming most of the technological shortcomings. Since then, the application of polycrystalline YAG has been widely studied as a viable substitute for single-crystals [2,5].

In this work polycrystalline yttrium aluminum garnets doped with chromium were synthesized using classical sol-gel method. In short, nitrates of Al and Y and Cr were dissolved in a copious amount of deionized water to which nitric acid was added up until $pH = 1$. After thoroughly mixing materials, stoichiometric amount of ethylene glycol was added to keep it constant between samples. Resultant gel was dried for 24 hours and annealed at $1000\text{ }^{\circ}\text{C}$ for 5 hours after which resultant powder was ground in agate mortar and analyzed using inductively coupled plasma optical emission spectrometry, x-ray diffractometry, scanning electron microscopy and photoluminescence measurements.

References

1. A.C. Berends, M.A. van de Haar, M.R. Krames, Chem. Rev. **120** (2020) 13461–13479.
2. S. Feng, H. Qin, G. Wu, H. Jiang, J. Zhao, Y. Liu, Z. Luo, J. Qiao, J. Jiang, J. Eur. Ceram. Soc. **37** (2017) 3403–3409.
3. J. Xu, B. Liu, Z. Liu, Y. Gong, B. Hu, J. Wang, H. Li, X. Wang, B. Du, Opt. Mater. **75** (2018) 508–512.
4. J. Kang, L. Zhang, Y. Li, Y. Ma, B. Sun, Y. Liu, T. Zhou, F.A. Selim, C. Wong, H. Chen, J. Mater. Chem. C. **7** (2019) 14357–14365
5. A. Ikesue, T. Kinoshita, K. Kamata, K. Yoshida, J. Am. Ceram. Soc. **78** (1995) 1033–1040.

SnS DEPOSITION BY CHEMICAL SOLUTION ROUTE

Asta Bronusiene, Skirma Zalenkiene*, Ricardas Kleinauskas, Ingrida Ancutiene

¹*Department of Physical and Inorganic Chemistry of Kaunas University of Technology,
Radvilėnų pl. 19, LT-50254, Kaunas, Lithuania*

* e-mail: skirma.zalenkiene@ktu.lt

Tin and sulfur binary compounds (Sn_xS_y) represent a rising class of electronic materials, that have been studied for some decades [1]. These materials are semiconductors. From all of tin sulfides, SnS is the most popular, because of non-toxicity [2], good chemical stability [3], high absorption coefficient [1], and typical p-type conductivity [2]. In addition, SnS has a multiple nature because of different structures (orthorhombic and cubic) by changing chemical parameters [2, 4, 5]. Moreover, different phases have their individual bandgap energy; for orthorhombic around 1.13 eV and for cubic around 1.73 eV [2]. So it shows the possibility to change the bandgap energy by changing the structure of SnS. Because of easy synthesis, the abundance of precursor elements, good properties have a possibility to use in a lot of areas, such as capacitors [6], solar cells [7], optoelectronic devices [8] and etc.

For the preparation of tin sulfide were used two different solvents: acetone or ethanol. Firstly the calculated amount of $\text{SnCl}_2 \cdot 2\text{H}_2\text{O}$ was ultrasonically dissolved in 5 mL of solvent for 10 min. In a small beaker was added 8 mL of thioacetamide as a source of sulfur. Then 10 mL of ammonia water and 12 mL of triethanolamine as complexing agent of tin ions were added. The prepared solution was diluted with distilled water to 100 mL and then heated at 70 °C for 3 hours using a magnetic stirrer. The solution was then filtered. The obtained precipitate was washed several times and left to dry at room temperature. X-ray diffraction (XRD) studies were performed with a D8 Advance diffractometer operating with Cu K_α radiation (Ni filter) at 40 kV and 40 mA voltage.

The phase composition of obtained materials was determined by contrasting their XRD patterns with those of known minerals. XRD analysis shows that synthesized material consists of two orthorhombic forms: α -SnS (JCPDS number 39-0354), known as mineral Herzenbergite, and β -SnS (JCPDS number 32-1361). XRD results showed that the mixture of tin sulfides was obtained. The two most intensive peaks are clearly seen in the diffractograms: one peak is assigned to α -SnS at $2\theta=26.6^\circ$, and the other – to β -form of SnS at $2\theta=31.76^\circ$. There are no significant differences between the solvents used. Using acetone, the peaks are slightly higher, but the diffraction pattern shows that the material is more amorphous. From the obtained results it could be said that a chemical solution deposition is a good technique for SnS fabrication and both solvents are suitable for it.

References

1. J. M. Gonzalez, K. Nguyen-Cong, et.al. J. Chem. Phys. **148** (2018) 194701.
2. D. Cabrera-German, J.A. García-Valenzuela, et.al. Mater. Sci. Semicond. Process. **89** (2019) 131–142.
3. J. Ye, L. Qi, B. et.al. J. Colloid Interface Sci. **513** (2018) 188–197.
4. D. Vikraman, S. Thiagarajan, et.al. Appl. Surf. Sci. **479** (2019) 167–176.
5. E. Barrios Salgado, D.E. Lara Llanderal, et.al. **35** (2020) 045006.
6. A. Rabkin, S. Samuha, et.al. Nano Lett. **15** (2015).
7. A. R. Garcia-Angelmo, R. Romano-Trujillo, et.al., Phys. Status Solidi Appl. Mater. Sci. **212** (2015) 2332–2340.
8. P. Akata Nwofe, M. Sugiyama, Phys. Status Solidi Appl. Mater. Sci. **1900881** (2020) 1–7.

NEW STRUCTURES TADF EMITTERS FOR THIRD GENERATION ORGANIC LIGHT EMITTING DIODES

Raminta Beresnevičiūtė^{1*}, Saulius Grigalevičius¹, Gintare Krucaite¹, Dovydas Blazevičius¹, Mangey Ram Nagar², Jwo Huei Jou²

¹Department of Polymer Chemistry and Technology, Kaunas University of Technology, Kaunas, Lithuania

²Department of Materials Science and Engineering, National Tsing Hua University, Hsinchu, 30013, Taiwan

* raminta.beresnevičiūtė@ktu.edu

Nowadays, there has been a lot of interest in third-generation organic light-emitting diodes characterized by thermally activated delayed fluorescence (TADF) [1]. This mechanism has been recently discovered and this is why the search for TADF materials and the formation of OLEDs using them are relevant in modern optoelectronics [2].

In this study, a new generation of electroactive compounds containing a 1,8-naphthalimide moiety were synthesized and characterized. These compounds were used in the emitting layers of organic light-emitting diodes as emitters. The structures of materials 1–3 are shown in Figure 1.

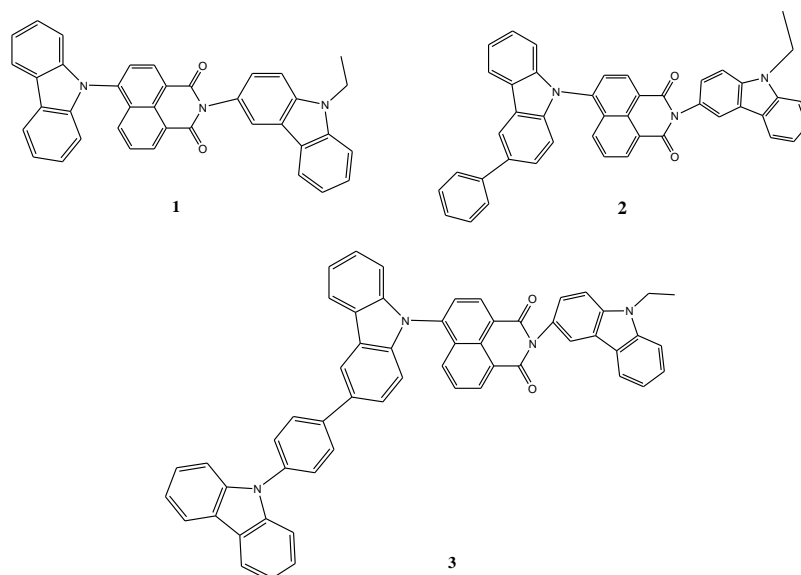

Fig. 1. Structures of compounds 1–3.

The materials demonstrated high thermal stability (246–366 °C) and their glass transition temperatures ranged from 133 to 160 °C. The compounds have been tested as emitters in organic light emitting diodes with a commercial host of di(N-carbazolyl)biphenyl (CBP). Between all the prepared devices, the best prototype was OLED using CBP host in the emissive layer and 7.5% of N-(9-ethylcarbazol-3-yl)-4-{3-[4-(carbazol-9-yl)phenyl]carbazol-9-yl}-1,8-naphthalimide as TADF emitter. The device has demonstrated a maximum luminance of 2377 cd/m², achieved 10 cd/A current efficiency, 9 lm/W power efficiency and 2.39 % maximum external quantum efficiency.

Acknowledgements. The OLED materials were developed in the frame of project funded by the Research Council of Lithuania (grant No. S-LLT-19-2) and by MOST (Taiwan).

References

1. T. Huang, W. Jang, L. Duan. *J. Mater. C.* 2018, **6**, 5577–5596.
2. B. Wex, B. R. Kaafarani. *J. Mater. Chem. C.* 2017, **5**, 8622–8653.

NEW CARBAZOLE BASED HOST MATERIALS FOR THERMALLY ACTIVATED DELAYED FLUORESCENT OLEDs

Dovydas Blazelevicius^{1*}, Raminta Beresnevičiūtė¹, Marius Eidimtas¹, Gintare Krucaite¹, Saulius Grigalevičius¹, Sujith Sudheendran Swyamprabha², Kiran Kishore Kesavan², Iram Siddiqui², Mangey Ram Nagar², Rohit Ashok Kumar Yadav², and Jwo-Huei Jou²

¹ Department of Polymer Chemistry and Technology, Kaunas University of Technology, Kaunas, Lithuania

² Department of Materials Science and Engineering, National Tsing Hua University, Hsinchu, Taiwan

* dovydas.blazelevicius@ktu.lt

Host materials are one of the key factors which improve the performance of OLEDs. An ideal host material should possess some characteristics. Firstly, the singlet and triplet energy of host should be higher than that of dopants, which prevents the reverse energy transfer from dopant to host and confines excitons in the emissive layer. Secondly, HOMO-LUMO energies of host materials should be as similar with adjacent layers as possible to reduce the driving voltage of the device. In addition, host material needs to possess a balanced hole-electron mobility. Lastly, good thermal and morphological stability is desired [1-3]. We introduce two novel TADF host materials containing two substituted carbazole moieties with central diphenyl sulfone electron accepting group as shown in Fig. 1.

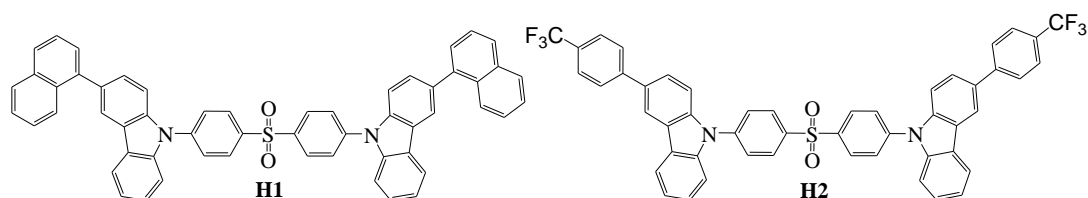

Fig. 1. Chemical structures of novel host materials H1 and H2.

The behaviour of the synthesized materials under heating was studied by DSC under a nitrogen atmosphere. When samples of the materials were heated, glass transitions were observed at 177 °C for **H1** and 213 °C for **H2** and no peaks due to crystallization and melting appeared during the further heating. We utilized the solution-processable host materials to fabricate the 2,4,5,6-tetra(9H-carbazol-9-yl)isophthalonitrile (4CzIPN) emitter based green TADF OLEDs. Among them, device which used host **H2** showed the best performance. It exhibited a maximum power efficiency of 20.8 lm/W, current efficiency of 33.1 cd/A, and external quantum efficiency of 13.7%. The excellent performance may be attributed to the low singlet-triplet energy gap (ΔE_{ST}), high photoluminescence quantum yield (PLQY) of emitting layer, high thermal stability, and unique porous morphology of the host material **H2**.

Acknowledgements. OLED materials were developed in the frame of project funded by the Research Council of Lithuania (grant No. S-LLT-19-2) and by MOST (Taiwan).

References

1. J.Y. Lee. *J. Inf. Disp.* **15** (2014) 139.
2. A. Lorente, P. Pingel, G. Liaptsis, H. Krüger, S. Janietz. *Org. Electron.* **41** (2017) 91.
3. Y.-M. Chen, W.-Y. Hung, H.-W. You, A. Chaskar, H.-C. Ting, H.-F. Chen, et al. *J. Mater. Chem.* **21** (2011)14971.

FLUORENE-BASED ENAMINES AS LOW-COST AND DOPANT-FREE HOLE TRANSPORTING MATERIALS FOR PEROVSKITE SOLAR CELLS

Šarūnė Daškevičiūtė^{1*}, Cristina Momblona², Kasparas Rakštys¹, Albertus Adrian Sutanto², Marytė Daškevičienė¹, Vygintas Jankauskas³, Alytis Gruodis³, Mohammad Khaja Nazeeruddin², Vytautas Getautis¹

¹ Department of Organic Chemistry, Kaunas University of Technology, Kaunas, Lithuania

² Institute of Chemical Sciences and Engineering, École Polytechnique Fédérale de Lausanne, Sion, Switzerland

³ Institute of Chemical Physics, Vilnius University, Vilnius, Lithuania

* sarune.daskeviciute@ktu.lt

The power conversion efficiency of perovskite solar cells is approaching the Shockley–Queisser limit, and therefore this technology is next to the commercialization stage [1]. Inexpensive and stable hole transporting materials are highly desirable for the successful scale-up. Most high performing devices generally employ expensive hole conductors that are synthesized via cross-coupling reactions which require expensive catalysts, inert reaction conditions and time-consuming sophisticated product purification [2]. In a quest to employ cost-effective chemistry to combine the building blocks, we explore enamine-based small molecules that can be synthesized in a simple condensation reaction from commercially available materials leading to an estimated material cost of a few euros per gram.

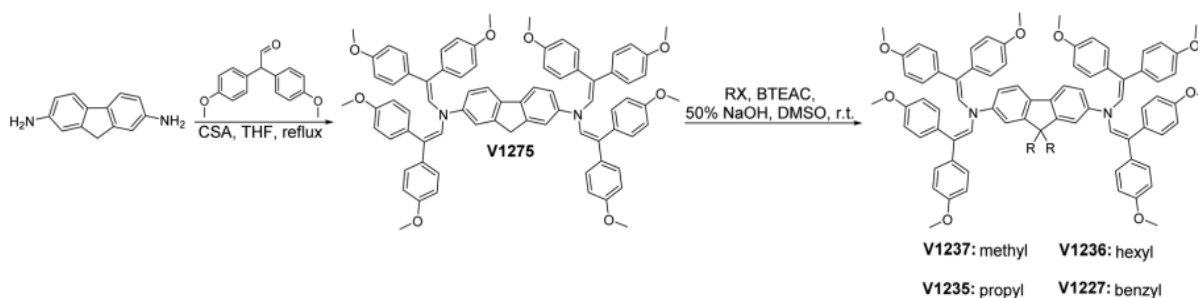

Fig 1. Structures and synthesis of novel hole transporting materials.

The synthesized fluorene-based enamines exhibit a very high hole mobility up to $3.3 \times 10^{-4} \text{ cm}^2 \text{ V}^{-1} \text{ s}^{-1}$ and enable the fabrication of perovskite solar cells with a maximum power conversion efficiency of 19.3% in a doped configuration and 17.1% without doping. In addition, both PSC systems demonstrate superior long-term stability compared to spiro-OMeTAD.

This work shows that hole transporting materials prepared via a simple condensation protocol have the potential to compete in terms of performance with materials obtained via expensive cross-coupling methods at a fraction of their cost and deliver exceptional stability of the final device.

References

1. NREL, Photovoltaic Research: Best Research Cell Efficiency Chart, <https://www.nrel.gov/pv/cell-efficiency.html>, accessed 28 April 2020.
2. T. P. I. Saragi, T. Spehr, A. Siebert, T. Fuhrmann-Lieker and J. Salbeck, *Chem. Rev.*, 2007, 107, 1011–1065.

SYNTHESIS AND PHOTOPHYSICAL PROPERTIES OF NOVEL PYRIMIDINE-BASED DONOR-ACCEPTOR EMITTERS

**Irina Fiodorova^{1*}, Rokas Skaisgiris², Toma Šapalaitė¹, Tomas Serevičius²,
Sigitas Tumkevičius¹, Saulius Juršėnas²**

¹*Institute of Chemistry, Faculty of Chemistry and Geosciences, Vilnius University,
Naugarduko 24, LT-03225 Vilnius, Lithuania*

²*Institute of Photonics and Nanotechnology, Faculty of Physics, Vilnius University,
Sauletekio 3, LT-10257 Vilnius, Lithuania.*

**irina.fiodorova@chgf.vu.lt*

TADF compounds are perfect candidates as the third generation emitters for OLED devices due to low synthesis cost (no noble metals atoms), emission yield reaching near unity [1] and efficient utilization of triplet excitons [2]. Triplet upconversion in TADF compounds is enabled by lowering the singlet-triplet energy gap (ΔE_{ST}) until the thermally activated reverse intersystem crossing becomes evident [3]. Minimization of ΔE_{ST} can be achieved by decoupling HOMO and LUMO in compounds constructed of donor (D) and acceptor (A) aromatic or heteroaromatic units. Recently, compounds containing pyrimidine heterocycle as an A unit have been demonstrated to be promising for TADF applications [3-5]. As a continuation of our work in the field of pyrimidine TADF emitters, we present herein results on the synthesis and photophysical characterization of novel pyrimidine derivatives bearing carbazole, acridane and phenoxazine moieties as D units (Fig. 1).

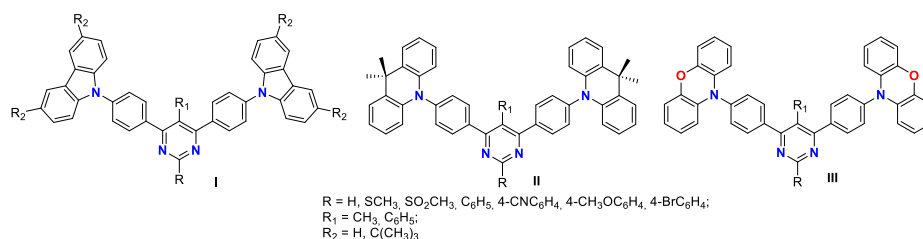

Fig. 1. General structures of pyrimidine-based emitters.

Synthesis of the pyrimidine-based emitters **I-III** and intermediates was carried out starting from easily accessible 4,6-diiodo-5-methyl(or phenyl)-2-methylthiopyrimidines by a combination of palladium-catalyzed Suzuki-Miyaura and Liebeskind-Srogl cross-coupling arylation, and Buchwald-Hartwig amination reactions. Optical properties of the synthesized compounds **I-III** were assessed by DFT calculations and investigated by absorption, time integrated and time-resolved fluorescence spectroscopies and fluorescence quantum yield and lifetime measurements. Details on the synthetic peculiarities and fluorescence properties of the synthesized materials will be presented in the report.

References

1. H. Kaji, H. Suzuki, T. Fukushima, K. Shizu, K. Suzuki, S. Kubo, T. Komino, H. Oiwa, F. Suzuki, A. Wakamiya, Y. Murata, C. Adachi. *Nat. Commun.* **6** (2015) 8476.
2. L.-S. Cui, A. J. Gillett, S.-F. Zhang, H. Ye, Y. Liu, X.-K. Chen, Z.-S. Lin, E. W. Evans, W. K. Myers, T. K. Ronson, H. Nakanotani, S. Reineke, J.-L. Bredas, C. Adachi, R. H. Friend. *Nat. Photonics* **14** (2020) 636.
3. T. Serevičius, R. Skaisgiris, J. Dodonova, K. Kazlauskas, S. Juršėnas, S. Tumkevičius. *Phys. Chem. Chem. Phys.* **22** (2020) 265.
4. T. Serevičius, R. Skaisgiris, I. Fiodorova, G. Kreiza, D. Banevičius, K. Kazlauskas, S. Tumkevičius, S. Juršėnas. *J. Mater. Chem. C* **9** (2021) 836.
5. T. Serevičius, R. Skaisgiris, J. Dodonova, L. Jagintavičius, D. Banevičius, K. Kazlauskas, S. Tumkevičius, S. Juršėnas. *ACS Appl. Mater. Interfaces.* **12** (2020) 10727.

CARBAZOLE DERIVATIVES AS HOLE TRANSPORTING MATERIALS FOR EFFICIENT SOLAR CELLS

Aistė Jegorovė^{1*}, Marytė Daškevičienė¹, Vygintas Jankauskas², Egidijus Karamauskas², Vytautas Getautis¹

¹ Department of Organic Chemistry, Kaunas University of Technology, Kaunas, Lithuania

² Institute of Chemical Physics, Vilnius University, Lithuania

* aisilc@ktu.lt

Nowadays, people cannot imagine their life without electricity. Renewable energy sources, such as solar energy is an alternative for non-renewable energy generation. Solar cells are devices that convert absorbed light into electricity and silicon solar cells are currently the most commonly used technology to do that. However, it has its own drawbacks and other high efficiency solar cell technologies have been developed. The efficiency of hybrid Solar Cells, for example perovskite, has increased significantly over the last decade. However, there are obstacles that need to be addressed in order for it to see a widespread use. One of them is the use of expensive charge-transporting semiconductors such as Spiro-OMeTAD or fullerene derivatives to obtain efficient devices [1]. Therefore, there is a vigorous search for cheaper and simpler methods for the synthesis of organic semiconductors. Carbazole class compounds have attracted the attention of scientist due to their plain synthesis and simple purification methods [2]. The aim of this project is to synthesize inexpensive carbazole class materials, that would be suitable as hole-transporting semiconductors for perovskite solar cells.

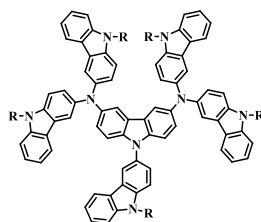

V1310: R = -CH₂CH₃;

V1322: R = -CH₂CH(CH₂CH₃)CH₂(CH₂)₂CH₃;

V1332: R = -CH₂(CH₂)₄CH₃.

Fig. 1. New carbazole derivatives (V1310, V1323, V1332).

All target materials are amorphous and has thermal stability greater than 400 °C. The obtained data shows that ionization potential is near up to 5 eV. The charge carrier mobility is in range of $3.7 \cdot 10^{-6} - 1.6 \cdot 10^{-6} \text{ cm}^2/\text{V}\cdot\text{s}$ in weak fields.

Table 1. Properties of new Carbazole derivatives (V1310, V1323 and V1332).

Compound nr.	T _g ^a , °C	T _d ^b , °C	I _p , eV	μ ₀ , V · cm ⁻¹ /s ⁻¹
V1310	216.8	511	4.86	1.6 · 10 ⁻⁶ ^c
V1323	97	411	4.99	3.7 · 10 ⁻⁶
V1332	109.1	482	4.87	3.5 · 10 ⁻⁶

^a Glass transition temperature, extracted from the second DSC heating cycle.

^b Decomposition temperature, corresponding to the 5% weight loss.

^c V1310 + PC-Z (1:1).

Based on the thermal and photoelectric properties, it can be stated that the materials can be used as HTM in Solar cells.

References

1. T. P. I. Saragi, T. Spehr et al. Spiro Compounds for Organic Optoelectronics, Chem. Rev. 107, 1011- 1065 (2007).
2. A. Singh et al. Bis(diphenylamine)-tethered carbazolyl anthracene derivatives as hole-transporting materials for stable and high-performance perovskite solar cells, ACS Appl. Energy Mater., 3, 11, 10752–10764 (2020)

NEW ELECTROACTIVE POLYMERS WITH ELECTRONICALLY ISOLATED 4,7-DIARYLFLUORENE MATERIALS FOR OLEDs

Gintare Krucaite^{1*}, Dovydas Blazevicius¹, Daiva Tavgeniene¹, Baohua Zhang², Aivars Vembris³, Saulius Grigalevicius¹, Raminta Beresneviute¹

¹Department of Polymer Chemistry and Technology, Kaunas University of Technology, Kaunas, Lithuania

²Center for Advanced Analytical Science, c/o School of Chemistry and Chemical Engineering, Guangzhou University, China

³Laboratory of Organic materials, Institute of Solid State Physics, University of Latvia, Kengaraga, Latvia

* e-mail address: gintare.krucaite@ktu.lt

The advantages that organic light emitting diode (OLED) based technologies offer in terms of brightness, viewing angle, contrast ratio, production cost, opportunity for flexible displays, etc. are not rivaled by liquid crystal-based displays [1-2]. It is well established that multilayer devices comprising hole transport layer (HTL), electron transport layer and emissive layer are necessary for efficient light emission [3-4].

New electro-active polymers having 4,7-diarylfluorene chromophores were prepared by cationic polymerization of the corresponding oxetane-based monomers. The structures of polymers **7-9** containing the electroactive 2,7-diarylfluorenyl chromophores are shown in Figure 1.

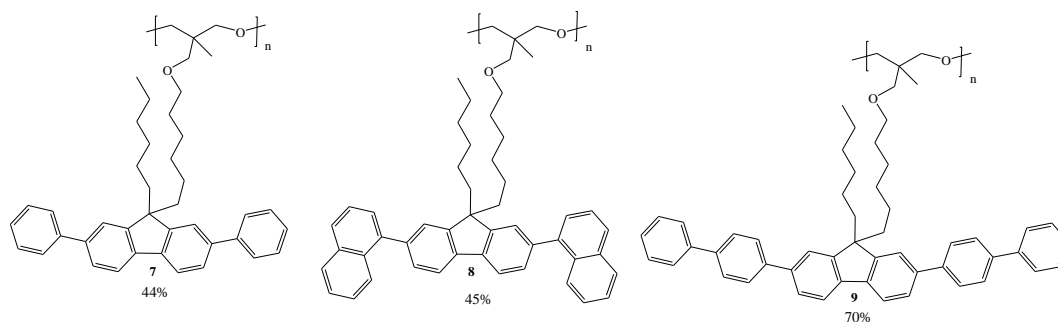

Fig 1. Structures of polymers **7-9**.

The amorphous materials demonstrated very high thermal stability (392-397 °C) and glass transition temperatures in a range of 28-63 °C. Electron photoemission spectra of thin films of the polymers confirmed that ionization potentials of the materials are depending on their chromophores and are in a range from 5.8 eV to 6.0 eV. The polymers have been tested as positive charges transporting layers in bilayer organic light emitting diodes with tris(quinolin-8-olato)aluminium as an emitter as well as electron transporting layer. An OLED device with polymer having electro-active 2,7-di(4-biphenyl)fluorene chromophores exhibited the best overall performance with low turn on voltage of 3 V, maximum brightness exceeding 200 cd/m² and current efficiency of 1.7 cd/A.

Acknowledgements. OLED materials were developed in the frame of project funded by the Research Council of Lithuania (grant No. S-LLT-19-2).

References

1. S. Jhulki, J. N. Moorthy, *J. Mater. Chem. C*, **6** (2018) 8280.
2. Cambridge Display Technology Ltd, <http://www.cdtltd.co.uk>
3. M. J. Deen, *Organic Semiconductor Devices*, 1999, p. 419.
4. S.S. Swayamprabha, M. R. Nagar, R. A. K. Yadav, S. Gull, D. K. Dubey, J.-H. Jou, *J. Mater. Chem. C*, **7** (2019) 7144.

SYNTHESIS OF HIGHLY POROUS PHOTOACTIVE WO₃ FOR GENERATION OF ClO⁻

M. Parvin, M. Petrulevičienė, I. Savickaja, V. Pakštas, A. Naujokaitis, R. Ramanauskas, J. Juodkazytė

*Center for Physical Sciences and Technology, Saulėtekio av. 3, Vilnius 10257, Lithuania
maliha.parvin@ftmc.lt*

Photoelectrochemical (PEC) generation of reactive chlorine species has attracted considerable attention because synthesis of H₂ on cathode can be coupled with production of high added-value chemicals such as HClO, H₂O₂, etc. on suitable photoanode [1]. Chloride anion oxidation (or hypochlorite production) is an attractive alternative to the oxygen evolution reaction due to a large amount of seawater as natural electrolyte on Earth and the massive application of hypochlorites in industrial water disinfection and sanitization [2-3]. In this study, porous WO₃ films were formed on fluorine-doped tin oxide (FTO) substrates by low temperature chemical bath deposition (CBD) and tested for PEC chloride oxidation.

To prepare WO₃ photoanode, Na₂WO₄·2H₂O was dissolved in deionized water under constant stirring, which was followed by the addition of citric acid and 3M HCl consecutively. Cleaned FTO substrates were immersed in the above solution and the deposition was allowed to proceed for two hours. The films were annealed at 400°C in air. The same procedure was repeated four times to obtain layers with increasing thickness. After first coating procedure comparably “thin” WO₃ nanostructured films with a layer thickness of several hundred nanometers and nanosheet morphology are typically obtained (Fig. 1a). After four chemical bath deposition cycles, several micrometers thick porous WO₃ layers were formed.

Fig.1b shows cyclic voltammograms (CV) of one-layer WO₃ photoanode measured in 0.5 M NaCl under dark and light to evaluate the PEC performance of the film. The photocurrents of CBD-deposited WO₃ films were found to be increasing with the layer thickness. Faradaic efficiency of PEC formation of ClO⁻ was evaluated.

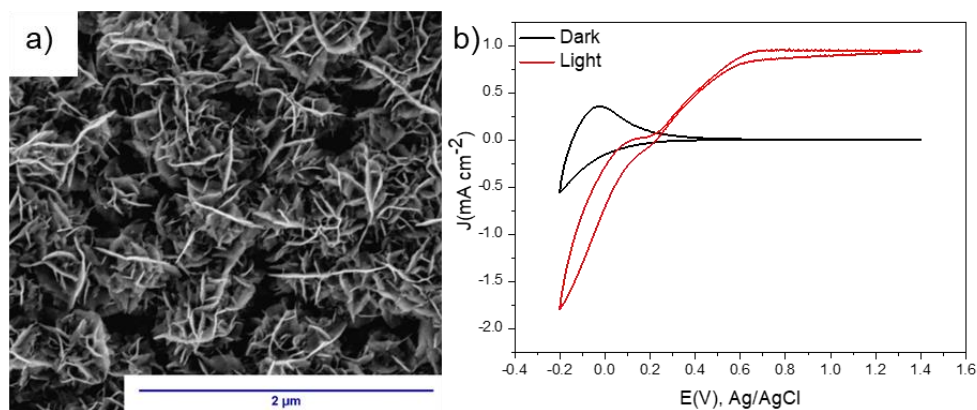

Fig. 1. a) SEM image of one-layer WO₃ coating prepared in CBD synthesis, b) CV of the same electrode in 0.5 M NaCl; illumination intensity 100 mW cm⁻²; potential scan rate 50 mV s⁻¹.

Acknowledgement:

This research was funded by the M-ERA.NET project “Multiscale computer modelling, synthesis and rational design of photo(electro)catalysts for efficient visible-light-driven seawater splitting” (CatWatSplit), Ref. Number: project8168.

References

1. X. Li et al. Appl. Catal. B Environ. **296** (2021) 120387.
2. A. Breuhausa-Alvarez, et al. J. Phys. Chem. C. **125** (2021) 8543.
3. S. Iguchi, et. al. Sustain. Energy Fuels. **2** (2018) 155.

CONCENTRATION QUENCHING OF ZINC-PHTHALOCYANINE IN THIN FILMS

**Justė Tamošiūnaitė^{1,2*}, Simona Streckaitė², Jevgenij Chmeliov^{2,3}, Andrius Gelzinis^{2,3},
Leonas Valkunas^{2,3}**

¹Life Sciences Centre, Vilnius University, Vilnius, Lithuania

²Department of Molecular Compound Physics, Centre for Physical Sciences and Technology, Vilnius, Lithuania

³Institute of Chemical Physics, Faculty of Physics, Vilnius University, Vilnius, Lithuania

*juste.tamosiunaite@gmc.stud.vu.lt

Sharply decreased emission intensity with increasing fluorophore concentration is known as concentration quenching, or aggregation-induced quenching [1], which tends to reduce fluorescence quantum yield [2]. This effect occurs in many systems from biology to optoelectronics [1, 3], and it may adversely affect the operation of the latter systems or devices.

In this study, Zinc 2,9,16,23-tetra-tert-butyl-29H,31H-phthalocyanine (TB-ZnPC) concentration quenching of thin films in toluene is investigated. These molecules are being used in diverse fields for their peculiar properties [4, 5], and, having a comparable structure to chlorophylls, they are applied as model systems. Experimental results in Fig. 1a show TB-ZnPC fluorescence spectra normalized to 2,49 M concentration where aggregation-induced quenching and fluorescence intensity decrease upon increasing concentration can be clearly seen. The same trend in Fig. 1b demonstrates fluorescence decay kinetics of 690 nm band getting faster.

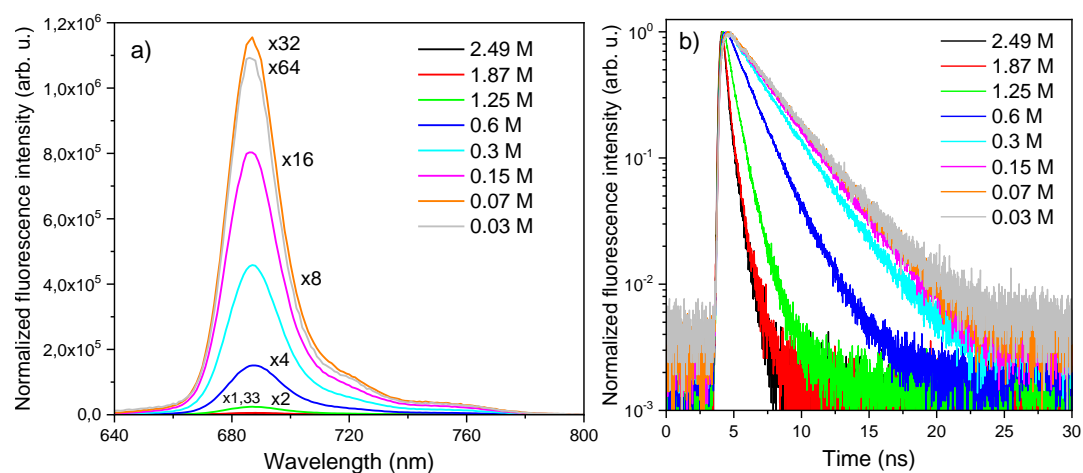

Fig. 1. a) Fluorescence spectra of TB-ZnPC thin films in toluene normalized to 2,49 M; b) Fluorescence decay kinetics of the 690 nm band of fluorescence spectra in panel a.

References

1. A. I. Burshtein, Concentration of noncoherent excitation in solutions, *Sov. Phys. Usp.* 27, 579-606 (1984).
2. Eftink M.R. Fluorescence Quenching: Theory and Applications. In: Lakowicz J.R. (eds) *Topics in Fluorescence Spectroscopy*. Topics in Fluorescence Spectroscopy, vol 2. Springer, Boston, MA (2002).
3. Y. Huang, J. Xing, Q. Gong, L.C. Chen, G. Liu, C. Yao, Z. Wang, H.L. Zhang, Z. Chen, Q. Zhang, Reducing aggregation caused quenching effect through co-assembly of PAH chromophores and molecular barriers, *Nat. Commun.*, 10 (2019) 1–9.
4. J. Mack, N. Kobayashi, Low Symmetry Phthalocyanines and Their Analogues, *Chem. Rev.*, 111 (2011) 281–321.
5. M. Yüzeroğlu, G. Keser Karaoğlan, G. Gümrükçü Köse, A. Erdoğan, Synthesis of new zinc phthalocyanines including schiff base and halogen; photophysical, photochemical, and fluorescence quenching studies, *J. Mol. Struct.*, 1238 (2021) 130423.

PHENOXAZINES HAVING VARIOUS ELECTRON ACCEPTOR OR DONOR FRAGMENTS AS NEW HOST MATERIALS FOR PHOSPHORESCENT OLEDs

Daiva Tavgeniene^{1*}, Dovydas Blazevicius¹, Raminta Beresneviciute¹, Gintare Krucaite¹,
Baohua Zhang², Simona Sutkuvieni^{3,4}, Saulius Grigalevicius¹

¹ Department of Polymer Chemistry and Technology, Kaunas University of Technology, Kaunas, Lithuania

² Center for Advanced Analytical Science, c/o School of Chemistry and Chemical Engineering, Guangzhou University, Guangzhou, PR China

³ Department of Biochemistry, Faculty of Medicine, Lithuanian University of Health Sciences, Kaunas, Lithuania

⁴ Department of Biochemistry, Faculty of Natural Sciences, Vytautas Magnus University, Kaunas, Lithuania

* daiva.tavgeniene@ktu.lt

Fluorescent materials were used as emitting materials of organic light emitting diodes (OLEDs), but the intrinsic low internal quantum efficiency of 25% of the fluorescent emitting materials limited the application of fluorescent OLEDs [1, 2]. It is known that the ratio of singlet excitons to triplet excitons is 1:3 and the triplet excitons cannot be utilized for light emission in common organic emitting materials because of non-radiative decay of triplet excitons via internal conversion process [3]. The radiative transition from the triplet excited state to the singlet ground state is a forbidden transition, but the transition can be allowed in organometallic complexes with heavy metals, which are used in phosphorescent OLEDs [4]. Suitable host materials should be used for the organometallic complexes. We will present a series of new phenoxazine-based derivatives as host materials for the triplet emitters. The synthesis of phenoxazine-based host materials 4–6 was carried out by a multi-step synthetic route. New materials 4–6 are shown in Figure 1.

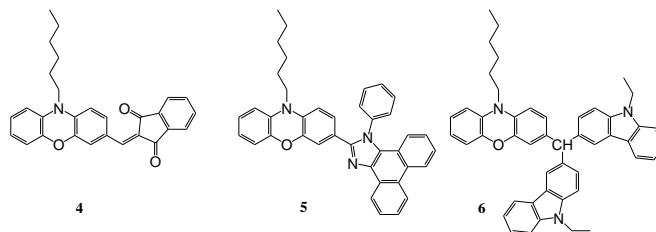

Fig. 1. New host materials 4–6.

The new electro-active materials were synthesized using phenoxazine as electron donor fragment connected with various electron acceptors or donors. Some of the materials formed homogeneous solid amorphous films with glass transition temperatures of 75–93 °C. Layers of the synthesized compounds showed ionization potentials of 5.24–5.56 eV. The compounds, which formed homogenous amorphous layers, were tested as host materials for green phosphorescent OLEDs by using green triplet emitter of bis[2-(2-pyridinyl-N)phenyl-C](acetylacetonato)iridium(III), Ir(ppy)₂(acac) as the guests. The device with the host of 3-[bis(9-ethylcarbazol-3-yl)methyl]-10-hexylphenoxazine exhibited the best overall performance. The efficient green OLED using the host demonstrated low turn-on voltage of 3.1 V, a maximum brightness of 5366 cd/m², external quantum efficiency exceeding 5.9% and maximum current efficiency of 18.3 cd/A.

Acknowledgements. OLED materials were developed in the frame of project funded by the Research Council of Lithuania (grant No. S-LLT-19-2) and by MOST (Taiwan).

References

1. G. Krucaite, D. Tavgeniene, J.V. Grazulevicius, et al. *Dyes. Pigm.* **106** (2014) 1.
2. C. Zhong, C. Duan, F. Huang, H. Wu, Y. Cao. *Chem. Mater.* **23** (2011) 326.
3. C. Adachi, M.A Baldo, M.E Thompson, S.R Forrest. *J. Appl. Phys.* **90** (2001) 5048.
4. G. Szafraniec-Gorol, A. Slodek, E. Schab-Balcerzak, et al. *Opt. Mater.* **62** (2016) 543.

Na_{1±Y}Ti_{2-x}M_x(PO₄)₃ (M = Al(III), Hf(IV), Mg(II), Zr(IV)) ISOVALENT AND ALIOVALENT SUBSTITUTION INFLUENCE ON AQUEOUS ELECTROCHEMICAL PROPERTIES AND ELECTRODE STABILITY

Skirmantė Tutlienė*, Jurgis Pilipavičius, Jurga Juodkazytė, Linas Vilčiauskas

Center for Physical Sciences and Technology, Saulėtekio av. 3, LT-10257, Vilnius, Lithuania

** skirmante.tutliene@ftmc.lt*

It is predicted that the electricity demand will increase from 30 to 50 percent by 2050, as a consequence of the ongoing transition from fossil fuels to renewable energy. Such a transition requires coordinated and comprehensive adaptations across a range of areas that affect society as a whole and should come together with state-of-the-art technologies. Efficient energy storage is considered to be the key for the successful and entire transition to renewable energy sources. Electrochemical energy storage technologies are and will be playing an important role for achieving this desirable goal – especially for mobile devices and the transportation sector, also stationary storage. In general, all applications require high energy and power density, low cost, safety, and preferably high sustainability. These characteristics vary significantly depending on the specific needs. Aqueous Na-ion based batteries are recognized as one of the promising candidates to replace Li-ion technologies, especially for stationary energy storage applications. NASICON-structured NaTi₂(PO₄)₃ (NTP) phosphate framework has already attracted a lot of attention and remains the most studied negative electrode material for aqueous Na-ion batteries. The major challenges to overcome are the NTP degradation in aqueous electrolytes during prolonged cycling and self-discharge. As it was presented in our previous research [1], the electrochemical properties of carbonaceous NTP composite electrodes are strongly dependent on the synthesis route. However, elemental composition is prerequisite for material conductivity and electrochemical properties [2].

Here, we present the results of electrochemical properties and cycling stability in aqueous electrolytes where Na_{1±y}Ti_{2-x}M_x(PO₄)₃ is substituted by M = Al(III), Hf(IV), Mg(II) and Zr(IV) in isovalent and aliovalent ratios. XRD, SEM, EDX, Cyclic voltammetry and Galvanostatic charge/discharge cycling experiment results will be presented at the conference.

Acknowledgements. This project has received funding from the European Regional Development Fund (Project No. 01.2.2-LMT-K-718-02-0005) under grant agreement with the Research Council of Lithuania (LMTLT).

References

1. S. Tutliene et al. *J Electrochem Soc.* 168, 060545;
2. P. Maldonado-Manso et al. *Solid State Ionics* 176 (17-18) p.1613-25 (2005)

MOLYBDENUM-DOPED BISMUTH VANADATE PHOTOANODE FOR PHOTOCATALYTIC FUEL CELL

Diana Vištorskaja^{1*}, Irena Savickaja², Jurga Juodkazytė², Maliha Parvin², Milda Petrulevičienė²

¹ Institute of Chemistry, Faculty of Chemistry and Geosciences, Vilnius University, Vilnius, Lithuania

² Center for Physical Sciences and Technology, Department of chemical engineering and technology, Vilnius, Lithuania

* diana.vistorskaja@chgf.stud.vu.lt

Photocatalytic fuel cell (PFC) is very attractive device for wastewater treatment with simultaneous electricity generation under sunlight. In such a system, electrons of the photoanode generated under illumination are transferred via the external circuit to the cathode to participate in reduction reactions and at the same time holes are released to be consumed in degradation of organic compounds [1]. BiVO₄ has been investigated as a promising photocatalyst due to its high photoactivity under visible light, moderate charge transport properties and relatively negative conduction band edge potential [2]. Metal-doping is widely used to enhance charge carrier generation and reduce recombination in BiVO₄ for catalyzing oxidation of organic compounds, inorganic species and water. Mo is a transition metal with half-filled orbital electronic configuration having six free electrons in its outer layer of electron structure, therefore Mo-doped BiVO₄ stands out for better n-type semiconductor and photoelectrochemical (PEC) properties.

The aim of this work was to investigate how different amounts of doped-Mo (1%, 5% and 10%) influence the PEC performance of BiVO₄ coatings. Evaluation of PEC response is presented in Fig. 1, where the increase in photoelectrochemical activity of BiVO₄ films with increase in Mo doping is observed. The results of open-circuit potential, cyclic voltammetry and chronoamperometric measurements in glucose-containing solutions will be presented at the conference.

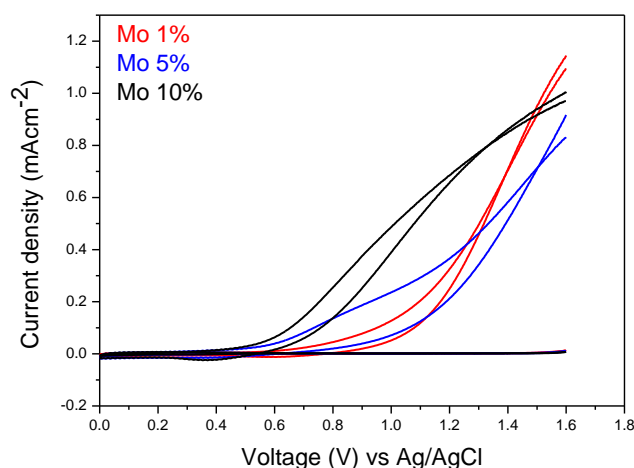

Fig. 1. Cyclic voltammograms of Mo-modified BiVO₄ samples in 0.5 M Na₂SO₄ solution in the dark and under illumination (potential scan rate 50 mV/s; intensity of illumination ~ 100 mWcm⁻²)

References

1. L. Xia, J. Bai, J. Li, Q. Zeng, X. Li, B. Zhou. *Applied Catal B, Environ.* **186** (2016) 224-230. A. Author, B. Author. *J. Am. Chem. Soc.* **490** (2018) 156.
2. Y. He, R. Yuan, M.K.H. Leung. *Mater. Lett.* **236** (2019) 394-397.

THERMALLY CROSS-LINKABLE HOLE-TRANSPORTING MATERIAL FOR EFFICIENT SOLUTION-PROCESSED ORGANIC LIGHT EMITTING DIODES

Deepak Kumar Dubey¹, Sujith Sudheendran Swayamprabha¹, Rohit Ashok Kumar Yadav¹, Daiva Tavgeniene^{2*}, Raminta Beresneviciute², Greta Jacunskaitė², Nizy Sara Samuel², Dovydas Blazelevicius², Dmytro Volyniuk², Saulius Grigalevicius^{2*}, Jwo-Huei Jou¹

¹ Department of Materials Science and Engineering, National Tsing Hua University, Hsinchu, Taiwan

² Department of Polymer Chemistry and Technology, Kaunas University of Technology, Kaunas, Lithuania

* saulius.grigalevicius@ktu.lt

Organic light-emitting diodes (OLEDs) have drawn enormous attention in academia and industries because of their amazing applications in both next generation full-color flat-panel display and solid-state lighting, owing to their potential for fabrication over a large area, light weight, rapid response and low power consumption devices [1, 2]. Thermal cross-linking units are usually used for cross-linkable hole transporting layer (HTL) materials because of the relatively simple deposition procedure. Remarkably, they can be proficiently applied for any type of cross-linkable material via annealing at high temperatures (> 100 °C), with formation of cross-linked electro-active layers [3, 4].

In this study, we have designed and synthesized a thermally crosslinkable HTL material **3** for solution-process based multilayer monochromatic and white OLEDs. The synthesis of the derivative **3** was carried out by the synthetic route shown in Scheme 1.

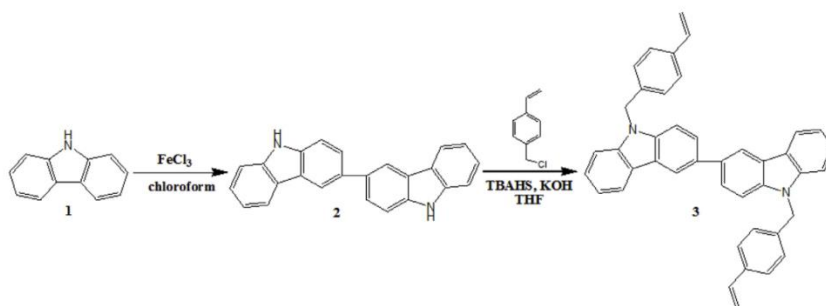

Scheme 1. Schematic illustration of synthesis of the cross-linkable hole transporting material **3**

The cross-linkable compound **3** features a larger bandgap and a higher triplet energy level. The material can be thermally cross-linked to form a solvent-resistant layer upon isothermal heating at 250°C for 30 min. The crosslinked layer possesses not only hole-collecting ability (HOMO = -5.25 eV), but also electron-confining capability (LUMO = -1.87 eV), which significantly improve the number of exciton into the desired recombination zone, hence noticeable efficiency enhancement for red, green, and blue OLEDs, especially at higher voltage. An OLED device consisting of low band gap red emitter displayed 58 and 45% increments in correspondingly power efficiency and current efficiency at 1000 cd cm⁻² as compared with similar device without the cross-linked compound **3** layer.

Acknowledgements. OLED materials were developed in the frame of project funded by the Research Council of Lithuania (grant No. S-LLT-19-2) and by MOST (Taiwan).

References

1. J.H. Jou, S. Sahoo, D.K. Dubey, R.A.K. Yadav, S.S. Swayamprabha, S.D. Chavhan, *J. Mater. Chem.* **16** (2018) 11492.
2. J. Tagare, S. Vaidyanathan. *J. Mater. Chem. C.* **6** (2018) 10138.
3. D.K. Dubey, S. Sahoo, C.W. Wang, J.H. Jou. *Org. Electron.* **69** (2019) 232.
4. W. Cho, S.S. Reddy, J. Kim, Y.R. Cho, S.H. Jin. *J. Mater. Chem. C.* **6** (2018) 11714.

DEVELOPMENT OF THE GLUCOSE BIOFUEL CELL BASED ON GLUCOSE OXIDASE MODIFIED ANODE AND CATHODE

Algimantas Kaminskas^{1*}, Asta Kausaite-Minkstimiene¹

¹ *NanoTechnas – Centre of Nanotechnology and Materials Science, Faculty of Chemistry and Geosciences, Vilnius University, Vilnius, Lithuanian*

* *algimantas.kaminskas1@gmail.com*

Fuel cells are electrochemical devices that can generate electrical energy using noble metal catalysts. Much cheaper and environmentally friendly energy generating devices are enzymatic biofuel cells (EBFC) which are capable of directly transforming chemical energy from redox enzymes to electrical energy via electrochemical reactions [1]. One of the most promising and widely studied EBFC is glucose biofuel cell (GBFC). GBFC consists of two components: bioanode, which is modified with glucose recognizing enzymes, such as glucose oxidase (GOx), and a biocathode, where reduction of oxidants such as O₂ or H₂O₂ takes place [2]. Despite the great effort of scientists, there are no GBFCs efficient enough for practical use, so, the biofuel cells where both anode and cathode are modified by the same enzyme in order to increase fuel cell performance rapidly gain more and more attention [3]. In this work, GBFC with both anode and cathode modified GOx electrodes was constructed and the operation was investigated.

Anode was constructed by three modification steps. First of all, 10-phenanthroline-5,6-dione (PD) was absorbed on the surface of the graphite rod (GR). Then the polymeric layers of poly-PD and poly(pyrrole-2-carboxylic acid) (PPCA) with encapsulated gold nanoparticles were formed by cyclic voltammetry (CV). Finally, the carboxylic groups, which occur in the PPCA layer, were activated by the mixture of NHS/EDC solutions and the GOx enzyme was covalently linked to the surface of the anode. This way, the modified anode could catalyze glucose oxidation and generate electrons using glucose as the main fuel source [4].

Similarly to the anode, the cathode was also prepared by three modification steps. Firstly, Prussian blue (PB) nanoparticles were synthesized in PPCA polymeric shell by CV. Then, the second layer of PPCA was deposited on the top of the first layer also by CV. Finally, GOx was covalently linked with the carboxyl groups of the PPCA layer. PB on the cathode surface could reduce H₂O₂, which occurs during the enzymatic glucose oxidation reaction, and immobilized GOx enzyme on the cathode surface increases performance of the fuel cell.

Using previously described anode and cathode electrodes a low-cost and high-efficiency GBFC was constructed and the performance of this biofuel cell was investigated. Also, the impact of glucose concentration and pH on the biofuel cell was studied. The obtained data indicates that this simple design biofuel cell can generate electricity using glucose as the main fuel source.

Acknowledgements.

This research was funded by a grant (No. S-LU-20-11) from the Research Council of Lithuania.

References

1. D. Leech, P. Kavanagh. Enzymatic fuel cells: Recent progress. *Electrochimica Acta*. 84 (2012) 223–234.
2. G. Slaughter. Enzymatic Glucose Biofuel Cell and its Application. *Biochips & Tissue Chips*. 05 (2015).
3. A. Koushanpour, M. Gamella. A Biofuel Cell Based on Biocatalytic Reactions of Glucose on Both Anode and Cathode Electrodes. *Electroanalysis*. 29 (2017) 950–954.
4. A. Kausaite-Minkstimiene, L. Glumbokaite. Reagent-less amperometric glucose biosensor based on nanobiocomposite consisting of poly(1,10-phenanthroline-5,6-dione), poly(pyrrole-2-carboxylic acid), gold nanoparticles and glucose oxidase. *Microchemical Journal*. 154 (2020) 104665.

THERMALLY ACTIVATED DELAYED FLUORESCENCE OF MULTI-CARBAZOLE DERIVATIVES WITH DIFFERENT ACCEPTOR MOIETIES

Malek Mahmoudi^{1*}, Dalius Gudeika¹, Dmytro Volyniuk¹, Stepan Kutsiy², Juozas V.Grazulevicius¹

¹*Department of Polymer Chemistry and Technology, Kaunas University of Technology, Radvilenu pl. 19, LT-50254, Kaunas, Lithuania*

²*Department of Electronic Devices, Lviv Polytechnic National University, S. Bandera 12, 79013, Lviv, Ukraine*

*malek.mahmoudi@ktu.edu

Thanks to the molecular design of thermally activated delayed fluorescence (TADF) compounds, their lowest excited singlet and triplet states lie very close energetically since charge donating and accepting moieties are spatially separated. This features of these compounds can lead to the thermally activated upconversion from the latter to the former state through reverse intersystem crossing which is actually the inverse transition processes of Phosphorescence compounds [1]. In our previous work, we developed various asymmetric multi-carbazole-based emitters by utilizing two different types of electron-withdrawing moieties which helped to tune their TADF properties and to achieve efficient blue emission. The compounds contained benzonitrile as the general accepting unit and the different additional acceptor moieties. [2] With this fundamental concern, we designed a series of highly efficient blue TADF emitters based on 3,6-di-tert-butylcarbazole as donors and two electron acceptors. Unlike the previous work which compounds consisted of benzonitrile as the general electron-withdrawing moieties, in this work general electron acceptor for all synthesized compounds was trifluoromethyl (CF₃) which is strong electron-withdrawing group and the difference of the compounds and aim of the work mostly were related to the variety of additional acceptor moiety attached through para substitution. The temperatures of thermal transitions of synthesized materials were measured by thermogravimetric analysis (TGA) and differential scanning calorimetry. During the TGA experiments compounds exhibited complete weight loss indicating sublimation. Their temperatures of the onsets of weight loss ranged from 433 to 462 °C. UV-VIS absorption and photoluminescence spectra of five compounds in both dilute solutions and neat films were recorded and non-structured photoluminescence spectra of compound neat films with peaks at 482, 508, 482, 490 and 480 nm for CN1-5, respectively, were observed. Additionally, Photoelectron emission spectroscopy was used for measuring ionization potentials of the solid-state of compounds in air and showing values in a relatively close range of 5.61–5.72 eV. The best optimized mCBP doped blue OLED exhibited maximum external quantum efficiency of 15.9%, maximum current efficiency of 42.6 cd A⁻¹, maximum power efficiency of 24.1 lm W⁻¹ along with stable electroluminescence spectrum with an emission peak of 477 nm and the CIE1931 colour coordinate of (0.16, 0.25).

Acknowledgements.

This work was supported by the project of scientific co-operation program between Lithuania and Ukraine “Development of highly efficient white light-emitting diodes utilizing organic emitters with exciplex and thermally-assisted fluorescence for lighting applications (LUW)” (grant No. S-LU-20-9).

References

1. T.J. Penfold, J. Phys. Chem. C. 119 (2015) 13535–13544.
2. M. Mahmoudi, D Gudeika, D Volyniuk, K Leitonas, R Butkute, I Danyliv, J V.Grazulevicius. Chemical Engineering Journal. **423** p. 130236 1-12 (2021)

SYNTHESIS OF $\text{Na}_3\text{MnPO}_4\text{CO}_3$ AND $\text{Na}_4\text{Mn}_3(\text{PO}_4)_2(\text{P}_2\text{O}_7)$ AS CATHODE MATERIALS FOR AQUEOUS NA-ION BATTERIES

Gintarė Plečkaitytė¹, Jurgis Pilipavičius¹, Saulius Daugėla², Tomas Šalkus², Jurga Juodkazytė¹, Linas Vilčiauskas¹

¹Center for Physical Sciences and Technology, Vilnius, Lithuania
²Institute of Applied Electrodynamics and Telecommunications, Vilnius University, Vilnius, Lithuania
gintare.pleckaityte@ftmc.lt

In order to meet the Paris climate agreement goals of future energy requirements [1], as well as the climate neutrality by 2050 [2], the development of renewable energy sources has become more and more urgent. Although the electricity generated by wind turbines, solar panels or hydropower is clean and safe, the supply is of intermittent nature and requires large-scale storage devices in order to obtain a balance. Electrochemical energy storage has many desirable features such as pollution-free operation, high round-trip efficiency, wide range of power and energy, long cycle life and low maintenance, as well as easy integration into the grid [3]. Various novel materials have been investigated and reported as cathodes and anodes for aqueous sodium-ion batteries, however there are still several problems such poor cycle stability, low energy density or low voltage which should be acknowledged [4]. After all, Mn-based (mixed)phosphate cathodes have a lot of advantages such as widespread availability of raw materials, low cost, high safety and non-toxicity. Moreover, Mn-based framework materials distinguish themselves as good candidates for fast sodium intercalation, small lattice volume changes and high insertion potentials [5].

In this work, we synthesized different Mn-based (mixed) phosphate framework materials such as $\text{Na}_4\text{Mn}_3(\text{PO}_4)_2(\text{P}_2\text{O}_7)$ and $\text{Na}_3\text{MnPO}_4\text{CO}_3$ via solid-state or hydrothermal synthesis methods. The structure and morphology of prepared materials were characterized by X-ray diffraction (Fig. 1.), scanning electron microscopy and thermogravimetric analysis. Moreover, ionic conductivity was measured of both samples. The electrochemical properties of prepared electrodes were investigated by cyclic voltammetry at different pH values.

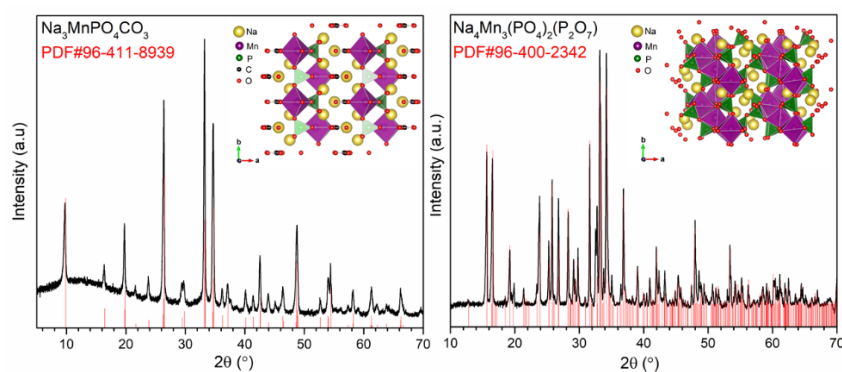

Fig. 1. X-ray diffraction patterns of $\text{Na}_4\text{Mn}_3(\text{PO}_4)_2(\text{P}_2\text{O}_7)$ and $\text{Na}_3\text{MnPO}_4\text{CO}_3$

Acknowledgements: This project has received funding from the European Regional Development Fund (Project No. 01.2.2-LMT-K-718-02-0005) under grant agreement with the Research Council of Lithuania (LMTLT).

References

1. The Paris Agreement. <https://unfccc.int/process-and-meetings/the-paris-agreement/the-paris-agreement>.
2. Implementing the SET Plan 2020 report. https://setis.ec.europa.eu/implementing-set-plan-2020-report-2020-11-23_en
3. D. Kundu, *Angew Chem Int Ed Engl*, 2015, 54, 3431-3448.
4. Y. Liu, *Adv. Funct. Mater* 2021, 2010445.
5. J. Kang, *ACS Sustain. Chem. Eng.* 2020, 8, 163-171.

WET PROCESS FEASIBLE NOVEL FLUORENE-BASED MOLECULAR HOLE TRANSPORTING LAYER FOR PHOSPHORESCENT ORGANIC LIGHT EMITTING DIODES

Sujith Sudheendran Swayamprabha⁴, Gintare Krucaite^{1*}, Deepak Kumar Dubey⁴, Kiran Kishore Kesavan⁴, Joydip De³, Mangey Ram Nagar⁴, Hsun Lee⁴, Simona Sutkuvienė^{2*}, Ernestas Zaleckas⁵, Greta Jacunskaitė¹, Nizy Sara Samuel¹, Santanu Pal³, Sun-Zen Chen⁴, Raminta Beresnevičiūtė¹, Saulius Grigalevičius¹, Jwo-Huei Jou⁴

¹ Department of Polymer Chemistry and Technology, Kaunas University of Technology, Kaunas, Lithuania

² Department of Biochemistry, Faculty of Natural Sciences, Vytautas Magnus University, Kaunas, Lithuania

³ Department of Chemical Sciences, Indian Institute of Science Education and Research, Mohali, India

⁴ Department of Materials Science and Engineering, National Tsing Hua University, Hsinchu, 30013, Taiwan

⁵ Institute of Agricultural Engineering and Safety, Agriculture Academy, Vytautas Magnus University, Kaunas, Lithuania

* e-mail address: simona.sutkuvienė@vdu.lt

Organic light emitting diodes (OLEDs) are widely used in high-quality displays and show great potential lighting because of their superior characteristics [1-2]. OLED possesses significant features for flat-panel display applications such as: self-emitting property, high luminous efficacy, full-color ability, wide viewing angle, high contrast, low power consumption, low weight, potentially large area, color displays, and flexibility [3].

In this study, we report a series of novel fluorene-based solution processable hole transporting materials (HTMs). The synthesis of the electroactive compounds (**3-5**) is shown in **Scheme 1**.

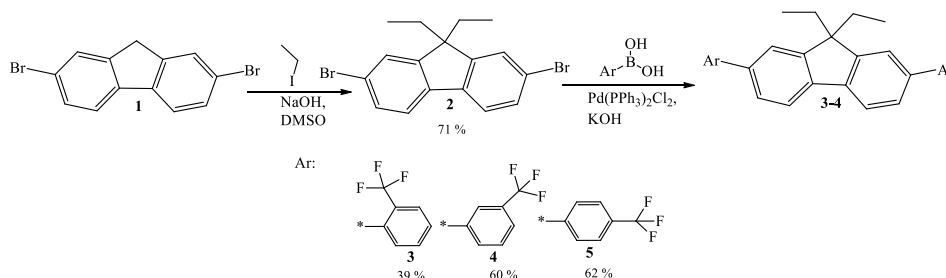

Scheme 1. Schematic illustration of synthesis of the fluorene type HTMs, **3**, **4**, and **5**.

The synthesized HTMs have an exceptional solubility in common organic solvents and possess good thermal stability to form morphologically stable films. The relevant molecular energy level alignment, adequate ionization potential and high triplet energies promote materials performance as a good hole transporting layer. Solution-processed yellow phosphorescent OLEDs were fabricated by utilizing these HTMs with a conventional yellow emitter iridium(III)bis(4-phenylthieno[3,2-c]pyridinato-N,C2')acetylacetonate doped in 4,4'-bis(N-carbazolyl)-1,1'-biphenyl host. The best device with HTM **4** showed an improvement of 54% in current efficiency from 23.3 to 35.8 cd/A and improvement of 14% in external quantum efficiency from 11.3 to 12.9%, compared to reference device containing commercial N,N'-Bis(naphthalen-1-yl)-N,N'-bis(phenyl)benzidine (NPD) as HTM.

Acknowledgements. OLED materials were developed in the frame of project funded by a grant from Kaunas University of Technology and Vytautas Magnus University.

References

1. H. Sasabe, J. Kido, J. Mater. Chem. C. **19** (2013) 1699.
2. H. Sasabe, J. Kido, J. Chem. Mater. **23** (2011) 621.
3. A. Sugimoto, H. Ochi, S. Fujimura, A. Yoshida, T. Miyadera, M. Tsuchida, J. Sel. Top. Quantum Electron. **10** (2004) 107.

ELECTROCHEMICAL PROPERTIES OF ELECTROPHORETICALLY DEPOSITED ZnO THIN FILMS

Jovita Grigonytė, Simona Ostachavičiūtė, Dovilė Sinkevičiūtė, Nerita Žmuidzinaičienė, Agnė Šulčiūtė*

Department of Physical and Inorganic Chemistry, Faculty of Chemical Technology, Kaunas University of Technology, Kaunas, Lithuania

* agne.sulciute@ktu.lt

ZnO is a multifunctional material due to its unique physical and chemical properties: high chemical stability, electrochemical coupling effect, wide absorption range, paramagnetic nature and high photostability [1-2]. However, one of the most important properties of ZnO is - photocatalytic activity, which allows it to decompose pollutants and water into hydrogen and oxygen gases. Therefore, the aim of this work is to investigate photocatalytic properties of ZnO thin films electrophoretically deposited on FTO glass.

Firstly, ZnO was produced by thermal synthesis from zinc acetate at 400 ° C for 1 hour. Then ZnO was electrochemically deposited on electrically conductive FTO glass. The constant potential was maintained from 15 V to 30 V with the step of 5 V, and the deposition time was from 5 min up to 30 min (step - 5 min) during electrophoresis.

Photoelectrochemical activity of prepared electrodes was investigated in a quartz cell in phosphate-buffer solution (pH 7). *General Electric F8W/BLB* lamp ($\lambda_{\max} = 366$ nm, power density $1.8 \text{ mW}\cdot\text{cm}^{-2}$, 2 cm placed from working electrode) was used as UV irradiation source.

The most stable electrodeposited ZnO thin films on FTO glass surface, with the highest photoactivity, was synthesized from ZnO formed by thermal synthesis at 400 ° C. The voltage of electrophoresis was 25 V and duration - 10 minutes. The highest photoelectrochemical and photoconversion efficiency values were 0.55 % and 0.2 % (**Fig. 1**), respectively.

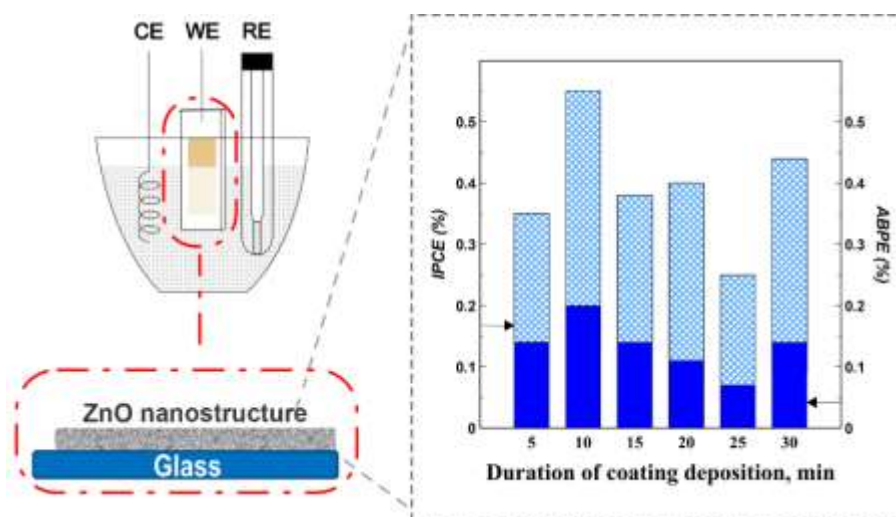

Fig. 1. The incident photon-to-current efficiency (IPCE) and applied bias photon-to-current conversion efficiency (ABPE) values for ZnO thin films in the phosphate-buffer solution (pH 7)

References

1. A. Moezzi, A.M. McDonagh, M.B. Cortie, Chem. Eng. J., **22**, (2012) 185-186.
2. E.M.P Steinmiller, K.S. Choi, Proc. Natl. Acad. Sci. U. S. A. By., **49**, (2009) 20633-20636.

TUNABLE CARBON COATING OF $\text{NaTi}_2(\text{PO}_4)_3$ FOR IMPROVED BATTERY PERFORMANCE

Nadežda Traškina¹, Jurgis Pilipavičius¹, Jurga Juodkazytė¹, Linas Vilčiauskas¹

¹Department of Chemical Engineering and Technology, Center for Physical Sciences and Technology (FTMC), Vilnius, Lithuania

nadezda.traskina@ftmc.lt

NASICON-type $\text{NaTi}_2(\text{PO}_4)_3$ (NTP) is the most thoroughly investigated aqueous Na-ion battery negative electrode material due to its high theoretical capacity, remarkable thermal stability and environmental benignity. Despite being highly ionically conductive, the material suffers from inherently low electron conductivity [1]. Additionally, poor cycling stability is observed owing to the dissolution of inorganic active material into water-based electrolyte [2]. Traditional particle coating by graphitization of glucose or citric acid (CA) does not guarantee an even conductive carbon layer. Growing a precisely-controlled polymer e.g. polydopamine (PDA) shell on the particles prior to the pyrolyzation is a sensible way to both enhance stability and conductivity of active material [3].

The aim of this investigation was to reveal the effect of in-situ polymerization conditions on the NTP electrochemical properties. A polydopamine shell is grown on the particles synthesized by a co-precipitation route with varying parameters such as initial pH and monomer concentration. The electrochemical performance of electrodes is investigated by galvanostatic charge/discharge cycling. The results suggest that polydopamine coating results in enhanced electrode capacity compared to conventional routes (Fig. 1).

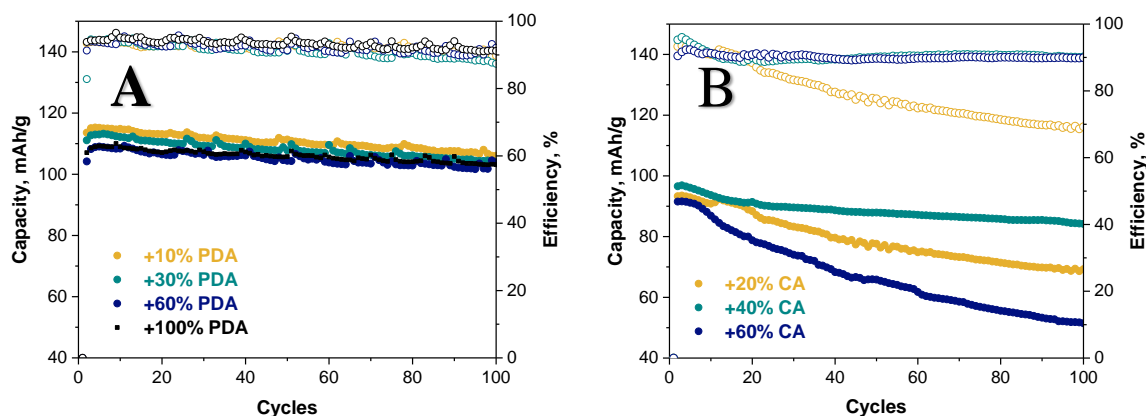

Fig. 1. Discharge capacities and charge/discharge efficiencies of electrodes prepared with a) PDA as a carbon precursor; b) CA as a carbon precursor.

References:

1. Xu et al. *Nano energy* **28** p. 224-231 (2016)
2. Plečkaitytė et al. *Journal of Materials Chemistry A* **9** p. 12670-12683
3. Chi et al. *RSC Advances* **4** p. 7795-7798 (2014)

Antimicrobial properties of sulphur-enriched, hydrophilic MoS₂ nano/microparticles and heterostructured Pd/MoS₂/Ti coatings

Rokas Žalneravičius^{1*}, Miglė Ragelytė¹, Vaclovas Klimas¹, Giedrė Grincienė¹, Renata Karpicz¹, Arūnas Ramanavičius¹, Arūnas Jagminas¹

¹ Electrochemical materials science, Center for physical sciences and technology, Vilnius, Lithuania

* rokas.zalneravicius@ftmc.lt

Recently, graphene-like two-dimensional molybdenum disulphide-based nanomaterials, especially their single or few-layered forms, usually named nanosheets (MoS₂-ns) or nanoknives, have received considerable attention as a promising antimicrobial agent. However, most previous studies indicate that without functionalization with other antimicrobial agents such as Ag, Ti₃C₂MXene, graphene oxide (GO) [1, 2], etc., the antimicrobial efficiency of MoS₂ is low and needs further improvements. In this study, the MoS₂-based nano/microparticles and coatings were synthesized through a simple, one-step hydrothermal approach without any other additives. The fabricated materials exhibited relatively small ($\Delta\theta = 18.7 \pm 2.5^\circ$) contact angle, resulting in their prominent hydrophilic properties, possibly caused due to sulphur-enriched MoS₂ composite as evidenced by TG/DTA–MS analysis. Such nanostructures can exhibit a better adhesion of biomolecules, thus facilitating the interaction between them, as confirmed by highly effective antimicrobial action (Fig.1). The present study examines the antimicrobial properties of hydrophilic, sulphur-enriched MoS₂ nano/microparticles as well as MoS₂-based coatings against various humans' pathogenic bacteria such as *Salmonella enterica*, *Pseudomonas aeruginosa*, *Escherichia coli*, *Staphylococcus aureus* (MRSA), *Micrococcus luteus*, and two *Candida* fungi, in particular *C. parapsilosis*, *C. krusei*. The MoS₂-ns (40 $\mu\text{g mL}^{-1}$) showed over 90 % killing efficiency against *S. aureus* MRSA bacteria and two *Candida* fungi within 24 h of exposure. Surprisingly, the petal-like MoS₂ microstructures and heterostructured MoS₂/Ti and Pd/MoS₂/Ti coatings also possess high antimicrobial potency and could be considered a promising antimicrobial agent and thus deserve further studies. The MoS₂-induced intracellular reactive oxygen species (ROS) production was evidenced by measuring the standard DCF dye fluorescence.

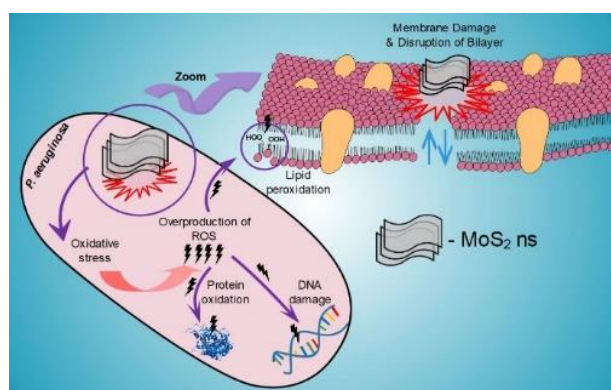

Fig. 1. Schematic illustration of various MoS₂ nanosheets antimicrobial pathways.

Acknowledgements. This research was funded by the European Social Fund under the No 09.3.3-LMT-K-712-19-0155 "Development of Competences of Scientists, other Researchers and Students through Practical Research Activities" measure.

References

1. S. Pandit, S. Karunakaran, S.K. Boda, B. Basu, M. De, ACS Appl. Mater. Interfaces. **8** (2016) 31567.
2. M. Zhu, X. Liu, L. Tan, Z. Cui, Y. Liang, Z. Li, K.W.K. Yeung, S. Wu, J. Hazard. Mater. **383** (2020) 121122.

MICROWAVE-ASSISTED SYNTHESIS OF GOLD-SILVER BIMETALLIC NANOPARTICLES

Edita Daublytė^{1*}, Tatjana Charkova²

¹Life Sciences Center, Vilnius University, Lithuania

²Department of Organic Chemistry, Center for Physical Sciences and Technology, Lithuania

*editadaublyte@gmail.com

Bimetallic nanoparticles, composed of two different metals, has higher catalytic, electronic, optical, and other properties than the corresponding monometallic particles. Bimetallic Au-Ag nanoparticles extend the surface plasmon resonance range (defined by UV-Vis absorption band) compared with single metal nanoparticles. Such an effect allows to probe molecules in wider Raman excitation range. [1]. Shell-isolated nanoparticle-enhanced Raman spectroscopy (SHINERS) is a non-destructive and sensitive method which can be applied to detect low concentrations of different analytes. For this application in order to improve stability and biocompatibility of the nanoparticles various coatings (SiO₂, MnO₂, TiO₂, etc.) are widely used [2].

Chemical reduction is one of the most commonly used methods for the synthesis of bimetallic nanoparticles. It allows flexibly modify composition, size, and shape of particles [1]. Compared with other synthesis conditions, microwave-assisted synthesis is becoming increasingly popular. It helps to reduce reaction time, energy consumption, and size distribution of the nanoparticles [3].

In this work 30±5 nm Au-Ag bimetallic nanoparticles were successfully synthesized under microwave irradiation. The formed uneven 1-4 nm silica (SiO₂) shell avoided direct chemical and electrical contact of the nanoparticles (Au-Ag@SiO₂) with analyte, and environment (Fig. 1). In order to apply the obtained nanoparticles, a self-assembled monolayer of 4-mercaptopbenzoic acid (4-MBA) was formed onto a gold plate and Au-Ag@SiO₂ nanoparticles were spread on it to amplify the Raman signals. The clear enhanced SHINERS spectrum of 4-MBA on a smooth gold plate was obtained (Fig. 2).

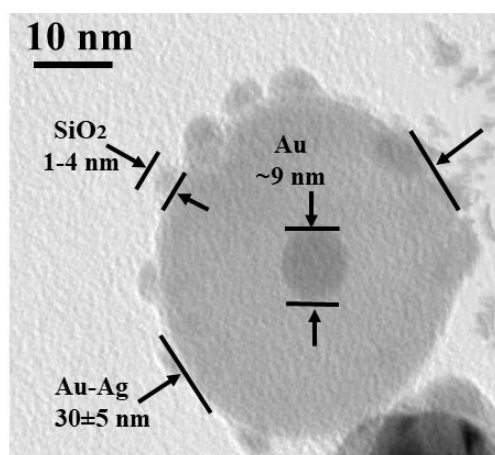

Fig. 1. HR-TEM images of 30±5 nm Au-Ag@SiO₂ nanospheres with 1-4 nm of silica shell.

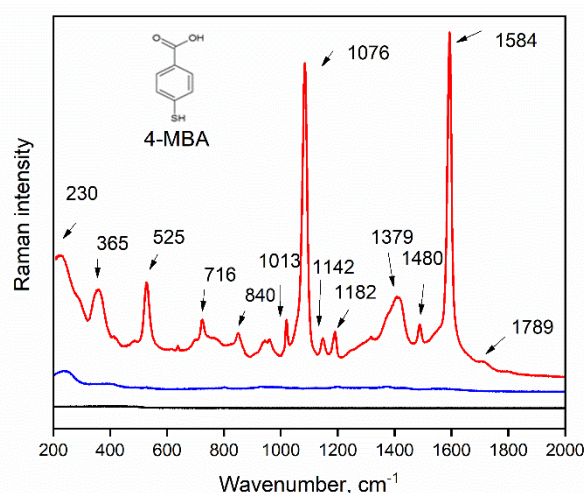

Fig. 2. Raman spectrum of 4-MBA adsorbed on a smooth Au surface without nanoparticles (A – black), Raman spectrum of Au-Ag@SiO₂ nanoparticles (B – blue) and SHINERS spectrum of 4-MBA with Au-Ag@SiO₂ nanoparticles.

References

1. P. Srinoi, Y.T. Chen, V. Vittur, M. D. Marquez, T.P. Lee. *Appl. Sci.* **8**(7) (2018) 1106.
2. J. F. Li, Y. J. Zhang, S. Y. Ding, R. Panneerselvam, Z. Q. Tian. *J. Chem. Rev.* **117** (2017) 5002-5069.
3. Y. J. Zhu, F. Chen. *J. Chem. Rev.* **114** (2014) 6462-6555.

GRAPHENE QUANTUM DOTS AS PROMISING NANOSTRUCTURES FOR STUDYING REDOX PROCESSES IN NEUTROPHILS

Tatsiana Kulahava¹, Lena Golubewa^{1,2*}, Danielis Rutkauskas², Kiryl Barysau^{1,3}, Alena Kavalenka³, Renata Karpicz², Polina Kuzhir^{1,4}

¹ Institute for Nuclear Physics, Belarusian State University, Minsk, Belarus

² State research institute Center for Physical Sciences and Technology, Vilnius, Lithuania

³ Faculty of Physics, Belarusian State University, Minsk, Belarus

⁴ Institute of Photonics, University of Eastern Finland, Joensuu, Finland

* lena.golubewa@ftmc.lt

Graphene quantum dots (GQDs) belong to the group of promising nanomaterials for the development of bio-sensing systems. GQDs consist of several sp²-hybridized graphene sheets, with a lateral size from several to 10 nm. The GQDs edge can be functionalized with hydroxyl, carbonyl, carboxyl groups. Functionalized GQDs are water-soluble and more stable in physiological media than graphene oxide. GQDs can also act as a donor/acceptor of electrons [1], thus being sensitive to reduction/oxidation processes in living systems, e.g., neutrophils.

The aim of this work was to investigate the mechanisms of interaction of GQDs with human neutrophils and reveal the potential for the detection of reactive oxygen and chlorine species (ROS/RCS) during cell activation. Neutrophils were isolated from the whole blood of healthy donors. GQDs were added to the cells at a concentration of 50 µg/mL, the incubation time was 30-90 min. Intracellular GQDs distribution, F-actin reorganization, myeloperoxidase (MPO) redistribution and release were performed via fluorescence microscopy.

Incubation of neutrophils with GQDs for 30 minutes led to their accumulation in cells and cell activation, although no cytotoxic effect was revealed. A more pronounced activation of neutrophils exposed to GQDs for 90 minutes was observed. This was manifested in a greater spreading of cells than in control, in the modification of actin cytoskeleton, secretion of MPO to the outer space and the formation of neutrophil extracellular trap-like structures. The intensity of GQDs fluorescence in neutrophils after 30 min of cell adhesion was three times higher than after 90 min of adhesion, indicating the destruction and/or disruption of the GQDs structure after penetration into neutrophils (Fig. 1). Hypochlorite ions, produced via neutrophils activation and MPO release led to a decrease in the GQD fluorescence via their structure changes allowing to estimate the intensity of reduction/oxidation processes (RCS increase).

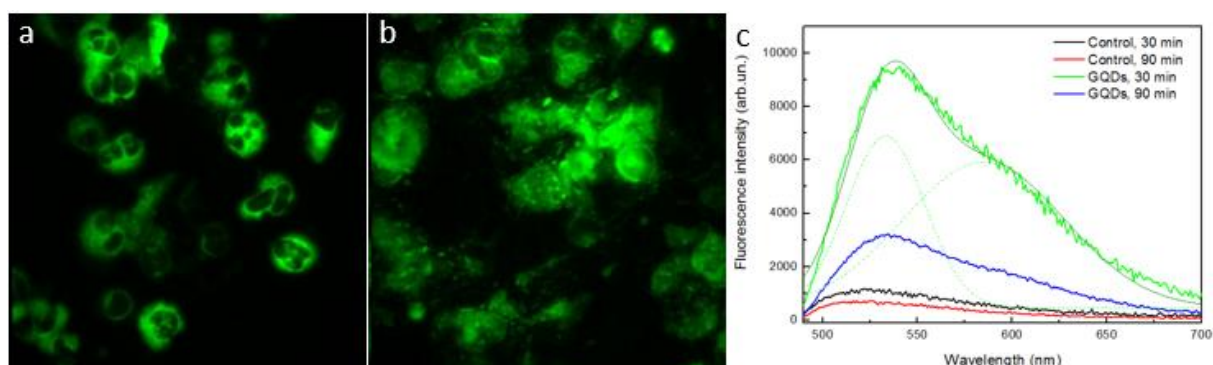

Fig. 1. Interaction of GQDs with neutrophils during cell adhesion: a – fluorescence images of neutrophils accumulated GQDs over 30 min, b – fluorescence images of cells accumulated GQDs over 90 min, c – fluorescence spectra of cells accumulated GQDs and in control cells. $\lambda_{\text{ex}} = 470 \text{ nm}$, $\lambda_{\text{em}} = 525 \text{ nm}$.

References

1. Fanping Shi, et al. J. Mater. Chem. B. 4 (2016) 3278.

HARDNESS AND WEAR PROPERTIES OF ALD HfO₂ LAYERS ON AZ31 ALLOY

A. Grigucevičienė, L. Staišiūnas, L. Valantiejtė, K. Leinartas, E. Juzeliūnas

Centre for Physical Sciences and Technology, Saulėtekio av. 3, LT-10257 Vilnius
e-mail asta.griguceviene@ftmc.lt

Exceptional mechanical properties of Mg and its alloys (lightness, great strength-to-weight ratio) allow them to be used in a variety of applications, including automobile and aviation industries, consumer electronics, biomaterials. However, the poor resistance of magnesium to corrosion and wear significantly limits and complicates its use. One of the ways to improve both corrosion performance and wear resistance of magnesium alloys is to coat their surface with chemically inert, mechanically hard oxides. Hafnium oxide (HfO₂) is considered as a promising candidate for this purpose [1, 2]. Atomic layer deposition (ALD) is the most suitable modern method to deposit thin oxide layers of a predictable thickness.

In this work, magnesium alloy AZ31 (Mg-3Al-Zn) was coated with HfO₂ layers of different thicknesses. The growth rate of HfO₂ (nm/cycle) was evaluated. Samples were tested as deposited and after annealing in nitrogen atmosphere at 350 °C for 5 hours. All samples were tested for hardness and wear with nanoindenter.

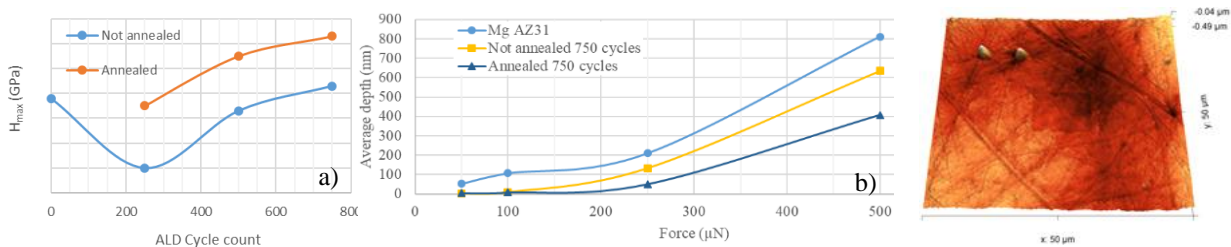

Fig. 1. Hardness of AZ31 alloy coated with HfO₂ coatings of various thickness (a) and average wear depth of uncoated and 750-cycle ALD coated AZ31 samples (b).

Fig. 2 SPM image of a wear trace on AZ31 alloy coated with 750 ALD cycles of HfO₂.

ALD growth of HfO₂ at 200 °C reactor temperature was determined to be linear in the region from 0 to 45 nm and the growth rate was calculated to be ~0.091 nm/cycle.

The surface hardness of AZ31 with natural oxide/hydroxide layer was better than that of samples with HfO₂ coatings of 250 and 500 ALD cycles. HfO₂ coating of 750 ALD cycles was already harder than natural oxide: ~4.3 GPa, compared to ~4 GPa for uncoated AZ31. The annealing improved hardness of the samples up to ~6.3 GPa for 750 cycle ALD coating.

Wear tests showed that HfO₂ coatings provided additional wear resistance for AZ31 samples compared to natural oxide/hydroxide layer. At 100 µN load, the annealed and not annealed samples with 750 cycle ALD coating, showed significant wear resistance with wear depth less than 15 nm. At higher loads some wear reduction effect was found which increased with the coating thickness. Hardness and wear resistance of all samples increased with annealing.

References

1. M. Li, Z. Jin, W. Zhang, Y. Bai, Y. Cao, W. Li, D. Wu, A. Li. *Sci. Rep.*, 9:10438 (2019); doi.org/10.1038/s41598-019-47049-z.
2. L. Staišiūnas, K. Leinartas, E. Juzeliūnas, D. Bučinskienė, A. Grigucevičienė, P. Kalinauskas, A. Selskis, S. Stanionytė. *Surf Coat Technol.*, 397 (2020) 126046; doi.org/10.1016/j.surfcoat.2020.126046.

GRAPHENE QUANTUM DOT CHARACTERIZATION USING BLACK SILICON BASED SERS SUBSTRATE

Lena Golubewa^{1,2*}, Aliona Klimovich¹, Marina Fetisova³, Tatsiana Kulahava², Ieva Matulaitienė¹, Renata Karpicz¹, Petri Karvinen³, Polina Kuzhir³

¹ State research institute Center for Physical Sciences and Technology, Vilnius, Lithuania

² Institute for Nuclear Physics, Belarusian State University, Minsk, Belarus

³ Institute of Photonics, University of Eastern Finland, Joensuu, Finland

* lena.golubewa@ftmc.lt

Fluorescent graphene quantum dots (GQDs) are promising nano-agents for optically guided targeted drug delivery. Accurate control of physical properties of the manufactured nanomaterials as well as determination of their surface chemistry is a paramount issue, as GQDs structure determines the efficiency of their application as imaging and diagnostic agent and surface chemistry governs the interaction of GQDs with living cells and tissues. Raman spectroscopy as well as surface-enhanced Raman spectroscopy (SERS) are highly specific methods of investigation and characterization of QGs. Black silicon-based substrate (bSi/Au) [1] has outstanding SERS properties and was applied for GQD analysis.

GQDs dispersed in water (1 mg/mL) were analyzed via Raman spectroscopy, however, the spectra obtained did not allow to perform GQD quality characterization (see Fig. 1, line 1 and inset). Investigation of GQD water suspension using bSi/Au SERS-active substrate made it possible to reveal the presence of additional surfactant used by the supplier to solubilize GQDs and identify PEG 1500 (or PEG of higher MW) as this surfactant (see Fig. 1, line 4 for GQD-PEG, line 2 for PEG). Using bSi/Au as SERS-substrates also allowed to demonstrate, that GQD-PEG treatment with oxygen plasma and additional washing effectively remove GQD functionalization with PEG leaving only GQDs (see Fig. 1, line 3).

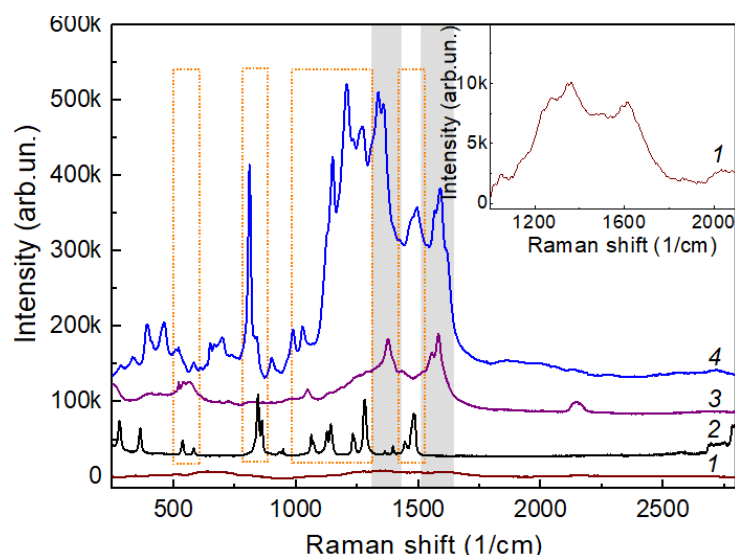

Fig. 1. Raman spectrum of GQDs dispersed in water (line 1), Raman spectrum of PEG-2000 (line 2), SERS spectrum of GQDs (1 mg/mL) on the bSi/Au substrate (line 4) and GQDs (1 mg/mL) after additional treatment for organics removal on bSi/Au (line 3). Inset: enlarged range 1000-2100 cm⁻¹ of GQDs Raman spectrum (line1). Excitation wavelength $\lambda_{ex} = 785$ nm, working power 50 mW, accumulation time 30 cycles per 10 s

Thus, GQD structure quality control and surface chemistry analysis could be successfully performed using bSi/Au SERS substrate.

References

1. L. Golubewa, et al. ACS Appl. Mat. Interfaces. **12** (2020) 50971.

EFFECT OF ULTRASONICATION ON MAGNETIC Fe₃O₄ NANOPARTICLES

Gytautė Sirgėdaite^{1*}, Lina Mikoliunaitė^{1, 2}

¹ Department of Physical Chemistry, Institute of Chemistry, Faculty of Chemistry and Geosciences, Vilnius University, Vilnius, Lithuania

² Department of Organic Chemistry, Center for Physical Sciences and Technology, Vilnius, Lithuania

* gytaute.sirgedaite@chgf.stud.vu.lt

Magnetic nanoparticles have gained popularity due to their thermophysical properties, which can be applied in various disciplines - biology, medicine, chemistry, physics. There are many applications of nanoparticles, and they are making progress in many fields of science: surface-enhanced Raman spectroscopy, drug delivery, therapeutic agents for cancer treatment, magnetic resonance imaging, biological sensors, catalysts, magnetic recording media [1]. The applications for the Fe₃O₄ nanoparticles often require a controllable synthesis to obtain particles with desirable size and tunable magnetic properties [2].

Iron oxide nanoparticles have gained popularity due to their easy availability, easy synthesis, and superparamagnetic properties [3]. The size of the nanoparticles ranges from 10 nm to 100 nm. The shape and size of nanoparticles are important parameters for synthesis and application because a large surface area increases reactivity, ion transfer, or contact. Besides, physical properties such as shape, composition, charge, and solubility can unpredictably change nanoparticles behaviour. It is therefore important to discover methods to obtain desired size, shape, and properties of magnetic nanoparticles [1].

Due to the inter-particle adhesion forces, nanoparticles become agglomerated, and their settlement can be observed due to the gravity forces. To achieve the maximum benefit from nanoparticles while working with them, it is desired to have an aggregate- and sediment-free structure where all the nanoparticles contribute to the dispersion. Improving the dispersion stability of nanofluids through ultrasonication has been shown to be effective. It could be noted that ultrasonication is a complicated physiochemical process, which can break down the agglomeration as well as create further aggregation, and many other effects [4].

In this work we have investigated effect of ultrasonication on magnetic Fe₃O₄ nanoparticles using different ultrasonication equipment, and effect on nanoparticles using different stabilizers and mediums.

Acknowledgements. This research is funded by the European Social Fund under the No 09.3.3-LMT-K-712 "Development of Competences of Scientists, other Researchers and Students through Practical Research Activities" measure.

References

1. A. S. Teja, P.Y. Koh, Progress in Crystal Growth and Characterization of Materials, **55** (1-2), 22-45 (2009).
2. S. Ge, et al., The Journal of Physical Chemistry C, **113** (31), 13593-13599 (2009).
3. D. Xiao, et al., Microchimica Acta, **183** (10), 2655-2675 (2016).
4. I. M. Mahbulul, et al., Ultrasonics Sonochemical, **26**, 361-369 (2015).

=

PREPARATION AND INVESTIGATION OF FILMS FROM PDMS AND SORBITOL MODIFIED POLYESTERS

Konstantinas Brazinski, Saulutė Budrienė

Department of Polymer Chemistry, Vilnius University, Vilnius, Lithuania

E-mail: kostiabraz@gmail.com; saulute.budriene@chgf.vu.lt

Tissue engineering as stated by Langer and Vacanti is an interdisciplinary field that applies the principles of engineering and the life sciences to the development of biological substitutes that restore, maintain or improve the function of biological tissue or the whole organ. One of the most important goals is to create a scaffold in which cells can live and multiply. Polyesters modified with various materials are used to make the scaffolds. Polydimethylsiloxane (PDMS) is an inorganic polymer that, due to its good properties, is widely used in all fields of engineering. It is characterized by chemical stability, thermal resistance, optical transparency, gas permeability, oxidation resistance, low toxicity, and biocompatibility [1]. However, PDMS has a hydrophobicity that limits its use and therefore it can be modified. Sorbitol is a monomer derived from renewable sources and is readily available today. Sorbitol has suitable properties for tissue engineering [2]. The aim of this work is to use sorbitol and PDMS to modify unsaturated polyesters and to evaluate their effect on the resulting films.

In this work, unsaturated polyesters were synthesized from azelaic acid, maleic acid anhydride, diethylene glycol, polydimethylsiloxane and sorbitol. The structure of polyesters was confirmed by FT-IR and ¹H NMR. Glycidyl methacrylate, butyl methacrylate and 2-hydroxyethyl methacrylate were attached to obtained polyesters to form UV curable films. Irgacure 651 initiator and UV light were used for curing. The structure of films was confirmed by FT-IR and elemental analysis. The Si amount in cured films ranged from 1.2 % to 3.8 %. The cured films were soaked in hexane, ethanol, and water prior to testing. The films were smooth and transparent, sparingly soluble in solvents. The mechanical properties of the films were determined. The higher relative elongation at break, but the lower Young's modulus of films were obtained when higher amount of sorbitol was used for synthesis of polyesters. The addition of 2-hydroxyethyl methacrylate as curing additive improved the relative elongation, but reduced the Young's modulus. The best mechanical properties showed the films when glycidyl methacrylate and butyl methacrylate were used for curing of films. The thermogravimetric analysis showed, that films obtained from polyesters were thermally stable and their decomposition took place in the temperature range of 150-480 °C. Differential scanning calorimetry analysis was performed to determine the glass transition temperatures of the films. The wetting angles of films obtained from unsaturated polyesters modified with PDMS and sorbitol were lower than obtained from PDMS or unmodified polyesters. The more sorbitol, the more hydrophilic films were obtained.

References

1. H. Zhang and M. Chiao. *J. Med. Biol. Eng.* **38**, 2015, p. 143–155.
2. V. Kavimani and V. Jaisankar. *J. Phys. Sci. Appl. India.* **4**, 2014, p. 507–515.

PHOSPHORYLCHOLINE-BASED DIBLOCK AND RANDOM BRUSH COPOLYMERS

Marijus Jurkūnas^{*}, Vaidas Klimkevičius, Ričardas Makuška

Faculty of Chemistry and Geoscience, Vilnius University, Lithuania

*marijus.jurkunas@chgf.vu.lt

Poly(2-methacryloyloxyethyl phosphorylcholine) (pMPC) is known as hydrophilic polymer with phosphorylcholine head groups which deliver unique properties – antifouling effect, penetration across cell plasma, fluid lubrication, etc. [1]. In a current work, a zwitterionic monomer MPC and an amphiphilic macromonomer poly(ethylene oxide) methyl ether methacrylate with different length (PEO₉MEMA or PEO₁₉MEMA) were selected to design a new zwitterionic brush copolymers that have promising potential for biomedical applications such as cartilage lubrication.

Random and diblock brush copolymers MPC-PEO_xMEMA (Fig. 1) were synthesized by RAFT polymerization using 4-(((butylthio)carbonothioyl)thio)-4-cyanopentanoic acid as a chain transfer agent (CTA) and 4,4'-azobis(4-cyanovaleric acid) as an initiator [2]. For the synthesis of the diblock copolymers, pMPC was polymerised first, precipitated, purified, dried, and then dissolved again for the synthesis of the second block of p(PEO₁₉MEMA) or p(PEO₉MEMA). The synthesized copolymers were studied by size exclusion chromatography with triple detection, ¹H NMR and FT-IR spectroscopy.

A series of random brush copolymers p(MPC-PEO₁₉MEMA) with degree of polymerization (DP) up to 100 and dispersity index Đ 1.3–1.4 and containing different amount of MPC units were synthesized. In another series of the copolymers, the block of pMPC with DP about 40 or 80 was rather monodisperse (Đ about 1.2) but the chain extension by the units of PEO₉MEMA or PEO₁₉MEMA was less successful giving diblock copolymers with higher dispersity (Đ about 1.5 and 1.6, respectively).

Study of biotoxicity and lubrication properties of the synthesized zwitterionic random and diblock brush copolymers p(MPC-PEO_xMEMA) is in progress.

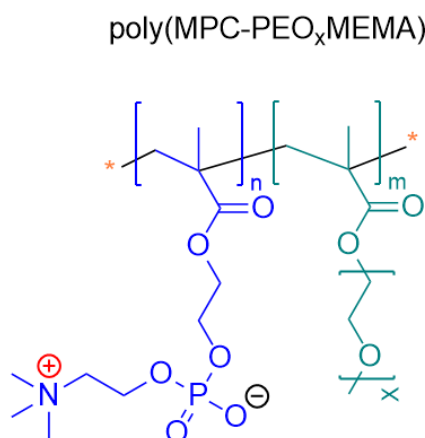

Fig. 1. Structure of random and diblock brush copolymers p(MPC-PEO_xMEMA)

References

1. Goda, T., Ishihara, K. and Miyahara, Y. J. Appl. Polym. Sci **132** (2015) 41766
2. Klimkevičius, V., Steponavičiute, M., Makuška, R., European Pol. J. **122** (2020) 109356

SYNTHESIS OF MICROCAPSULES CONTAINING DIISOCYANATE AS A HEALING AGENT

Liepa Pastarnokienė*, Tatjana Kochanė, Andželika Jankauskytė, Ričardas Makuška

Department of Polymer Chemistry, Faculty of Chemistry and Geosciences, Vilnius University, Vilnius, Lithuania

** liepa.pastarnokiene@chgf.stud.vu.lt*

There are several ways to produce self-healing coatings, and incorporation of microcapsules containing a healing agent into the coatings' formulations is one of the most studied approaches. Using microcapsules system for self-healing, the active agent released from the ruptured microcapsules can repair the damage and continue the role of the protective layer [1]. The double-capsule system based on the encapsulation of two reactive healing agents is easy to operate and achieve. The healing system such as epoxy-amine, epoxy-thiol, isocyanate-thiol and isocyanate-amine had shown good self-healing and corrosion protection features in coating applications [2].

In this work, encapsulation of isophorone diisocyanate as a healing agent was studied. Microcapsules with isophorone diisocyanate core and single or double-layered shell were synthesized using *in situ* polymerization in an oil-in-water emulsion. The single-layered shells of the microcapsules were formed by poly(melamine-formaldehyde), poly(urea-melamine formaldehyde) or polyurethane. Microcapsules with double-layered shells were synthesized by forming poly(urea-formaldehyde)/polyurethane envelopes. The microcapsules were prepared in high yields (45–78 %). The effect of the reaction time, type and concentration of stabilizers on size and properties of the microcapsules was evaluated. Size distribution and surface structure of the microcapsules were evaluated by optical microscopy and SEM analysis. Using gumarabic as a stabilizer, stable microcapsules with single layered shells and size in the range of 10–100 μm were obtained. Using poly(ethylene-maleic anhydride) copolymer as a stabilizer, double layered poly(urea-formaldehyde)/polyurethane microcapsules with the size of 30–60 μm were prepared. Thermal properties of the microcapsules were evaluated by TGA and DSC analysis. Successful encapsulation of isophorone diisocyanate was confirmed by FTIR spectra.

Acknowledgements. The study was supported by the project of the EU funds investment tool “Eksperimentas” „POLYASPARTIC COATINGS WITHOUT VOLATILE ORGANIC COMPOUNDS FOR WOODEN SURFACES“, No 01.2.1-LVPA-K-856-01-0089.

References

1. D. G. Bekas, K. Tsirka, D. Baltzis, A. S. Paipetis. *Composites Part B* **87** (2016) 92-119.
2. M. Guo, Y. He, J. Wang, X. Zhang, W. Li. *J. Appl. Polym. Sci.* **137** (2019) 48478.

SYNTHESIS AND CHARACTERIZATION OF POLYESTERS MODIFIED WITH CITRIC ACID AND PDMS

Kamilė Vonžodaitė, Saulutė Budrienė

*Department of Polymer chemistry, Vilnius University, Naugarduko 24, LT-03225 Vilnius, Lithuania
E-mail: kamile.vonzodaite@chgf.stud.vu.lt*

Polyesters are used in tissue engineering industry due to their biodegradability and biocompatibility. However, research for an overall easy to produce biocompatible and non-toxic elastomer with suitable mechanical properties is on-going [1]. Polydimethylsiloxane (PDMS) has been used in the industry for its transparency, easy manufacturing and low cost, but its application is limited due to hydrophobicity and poor mechanical properties. While PDMS surface can be modified to increase hydrophilicity, it is, usually, a short-term solution [2, 3]. These drawbacks could be counteracted by increasing polyester functionality with addition of PDMS and citric acid.

In this study, polyester was produced by two-step method. In the first step, polycondensation reaction between azelaic acid, maleic acid anhydride and diethylene glycol was carried out. Afterwards, α,ω -dihydroxy-polydimethylsiloxane and citric acid were added. Structure of obtained polyesters was evaluated by FT-IR and ^1H NMR spectroscopy. Films from modified polyesters were produced by adding curing agents: glycidyl methacrylate, butyl methacrylate and/or hydroxyethyl methacrylate together with photo initiator 2,2-dimethoxy-2-phenylacetophenone and curing under UV light. Cured films were analyzed by FT-IR spectroscopy. Solubility and degree of swelling in three different solvents: hexane, ethanol and water were determined for all produced films. Solubility and degree of swelling was the highest in ethanol and the lowest in hexane. After solubility test, elemental analysis of cured films was used to determine amount of silicon, which ranged from 1.5 to 2.3 %, depending on synthesis and curing conditions. This proved, that PDMS was present in formed polyester and films, too. The effects of molar ratios of initial materials and hardening agents (based on maleic acid anhydride) on wettability and mechanical properties of films were investigated. Water contact angle ranged from 77° to 97° and was lower than for commercial PDMS ($>100^\circ$) [4]. Elongation at break ranged from 48 to 65 %. It decreased with increasing amount of citric acid and the best results were obtained when hardening agents glycidyl methacrylate and butyl methacrylate were used. Produced films showed good mechanical properties. Young's module ranged from 6 to 26 MPa. Thermogravimetric analysis showed that films were thermally stable, and degradation occurred in a two-step process, starting at 150°C . During the first step of degradation, cross-linked structure was broken up and linear macromolecules were obtained. During the second step, macromolecules were broken up into smaller fragments due to decomposition of ester bonds and PDMS segments. Glass transition temperature of films was determined by DSC method and ranged from -6° to 11° for first heating and from 4° to 15° for second heating.

References

1. Ye, H., Zhang, K. D. Kai, Z. Li, X. Loh. *Chem. Soc. Rev.* **47**, 12 (2018) 4545–4580.
2. Y. Chuah, Y. Koh, K. Lim, N. Menon, Y. Wu, Y. Kang. *Sci Rep* **5** (2016) 18162.
3. S. H. Tan, N.-T. Nguyen, Y. C. Chua, T. G. Kang. *Biomicrofluidics*. **4**, 3 (2010) 32204.
4. T. Trantidou, Y. Elani, E. Parsons, O. Ces. *Microsyst. Nanoeng.* **3** (2017) 16091.

POROUS POLYCAPROLACTONE SCAFFOLD FABRICATION FOR CARTILAGE REGENERATION VIA CRYO-ELECTROSPINNING

Lauryna Dabasinskaite^{1*}, Justinas Masionis¹, Edvinas Krugly¹, Odeta Baniukaitiene¹, Darius Ciuzas¹, Dainius Martuzevicius¹

¹ Faculty of Chemical Technology, Kaunas University of Technology, Kaunas, Lithuania

* Corresponding author: lauryna.dabasinskaite@ktu.lt

Introduction. Tissue engineering (TE) can overcome limited long-term repair success or unacceptable side effects of surgical treatments currently applied for the treatment of injury or osteoarthritis [1]. Furthermore, TE scaffolds can mimic the structure of the natural ECM, providing great potential in bone and cartilage regeneration. An ideal scaffold should have an interconnected porous structure that allows the diffusion of nutrients and cell penetration, serving as a substrate for tissue growth [2]. Due to their high porosity and tunable morphology, electrospun scaffolds can be used for cartilage tissue applications.

Methods. A blend of a biodegradable synthetic polymer poly(ϵ)caprolactone (PCL) and regenerated cellulose (CEL) was used to fabricate a fibrous and porous scaffold by the solution cryoelectrospinning technique. The effects of relative humidity within the electrospinning chamber on fibre morphology has been researched, as characterized by SEM and μ CT techniques. The fiber and pore diameters were calculated using ImageJ software by dividing the SEM image into four equal quartiles and selecting all points in one quartile. The differences between samples were assessed using two sample T-tests implemented in the OriginPro software data analysis package.

Results and conclusions. The average pore size of $112 \pm 26 \mu\text{m}$, fiber size of $9.7 \pm 2.5 \mu\text{m}$ and 90 % porosity were achieved, at the same time, RH did not seem to significantly affect the morphology of the fibrous scaffolds. However, as described elsewhere, the most beneficial optimal range of pore diameter is between 100 and 250 μm and porosities greater than 90%, which means that our scaffold could be successfully applied for cartilage tissue engineering [3].

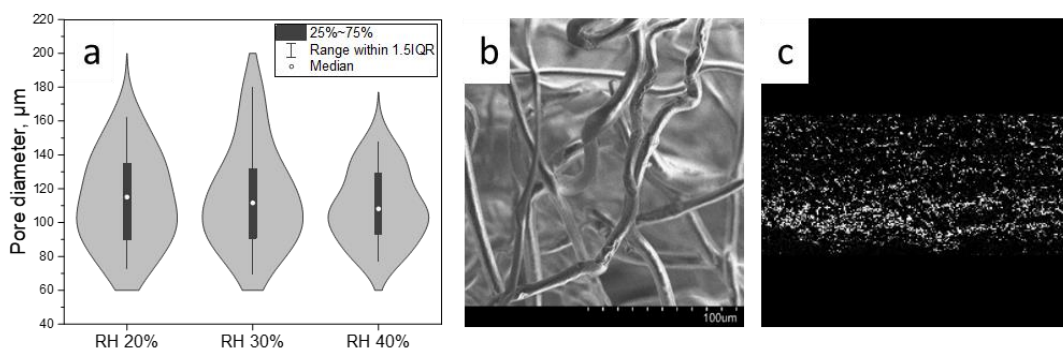

Fig. 1. Fiber and pore size analysis using different related humidity (a), SEM, (b), 2D μ CT, (c) images of the PCL-CEL scaffold (30% RH)

References

1. Eftekhari, A.; Maleki Dizaj, S.; Sharifi, S.; Salatin, S.; Rahbar Saadat, Y.; Zununi Vahed, S.; Samiei, M.; Ardalan, M.; Rameshrad, M.; Ahmadian, E.; et al. The Use of Nanomaterials in Tissue Engineering for Cartilage Regeneration; Current Approaches and Future Perspectives. *Int. J. Mol. Sci.* **2020**, *21*, 536, doi:10.3390/ijms21020536.
2. Camarero-Espinosa, S.; Rothen-Rutishauser, B.; Foster, E.J.; Weder, C. Articular cartilage: from formation to tissue engineering. *Biomater. Sci.* **2016**, *4*, 734–767, doi:10.1039/C6BM00068A.
3. Wang, Z.; Wang, J.; Wang, H.; Huang, J.; Liu, S.; Zhu, Y.; Wang, Y.; Peng, J.; Wang, A.; Yu, C.; et al. Comparison of the properties of a native articular cartilage extracellular matrix-derived oriented scaffold and the chondro-gide bilayered scaffold-cartilage tissue engineering. *Int. J. Clin. Exp. Med.* **2016**, *9*, 10627–10638.

IMPORTANCE OF MASTICATION FOR POLYISOPRENE RUBBER

Audrė Kalinauskaitė^{1*}, Marijus Jurkūnas², Svajus Asadauskas¹

¹ Department of Chemical Engineering and Technologies, Center for Physical Sciences and Technology (FTMC), Vilnius, Lithuania

² Faculty of Chemistry and Geoscience, Vilnius University (VU), Lithuania

*audre.kalinauskaite@ftmc.lt

Viscosity, elasticity and many dynamic-mechanical properties of elastomers can be affected by ageing. Some degradation might be irreversible, but even more evident transformations might take place due to migration, crystallization, rearrangement and similar transient mechanisms. In this study synthetic cis-1,4-polyisoprene rubber (p-isoprene) without added components was selected to observe ageing effects on a simple elastomer. Storage modulus G' was monitored after masticating the elastomer and storing it up to 8 days at room temperature. Long polymer chains can experience shear forces during mastication, but mechanochemical damage remains minor [1]. Mastication should homogenize lamellae, crystals and similar macromolecular agglomerates within the elastomer without much chemical degradation.

Bulk p-isoprene was sliced into small slabs of ~30 g and masticated on the two-roll mill HTR-300 (Hartek, China) for 25 passes at 22°C. Rolls of 360 mm OD were compressed to near-minimal nip size of 0.8 mm ± 30% and their velocity was set at 8 rpm with 1:1.25 sliding ratio. Specimens of p-isoprene were shaped into discs of 35 mm OD and 5 mm thick, weighing ~5 g, and were stored in dark cabinet. After ageing, the discs were placed in between disposable polymer sheets of 23 μm thickness and tested in a moving-die rheometer D-MDR 3000 (Montech, Germany) with biconical dies per ASTM D6204. Frequency sweep was used to record G' from 0.01 Hz to 50 Hz with 0.5% strain rate, 0.3 MPa interfacial pressure and 5 min hold time for each frequency value. After the first frequency sweep at 25°C each disc was heated to 50°C and the same measurement repeated without releasing the compression, Fig. 1.

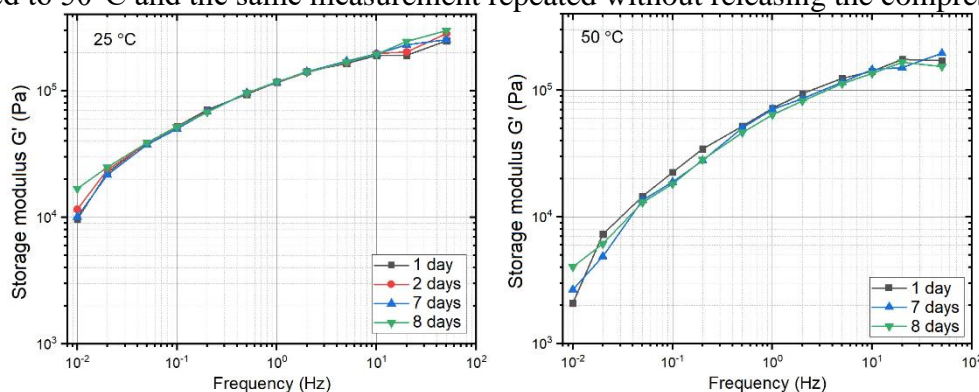

Fig. 1 Effects of mild ageing at room temperature on viscoelasticity of p-isoprene

The impact of ageing on storage modulus was not detectable at 25°C, but some drop of storage modulus G' at 50°C can already be observed. The magnitude is not large and might be considered negligible in some cases. Nevertheless, just 1 week at room temperature appears to lead to detectable changes in a relatively simple polymer like p-isoprene. Elastomer formulations with fillers, plasticizers, vulcanization additives and other functional additives are very likely to undergo much more rapid and significant transformations. Evidently, mastication is very important in testing elastomer formulations and should be widely enforced.

References

1. C. Wortmann, P. Lindner, F. Dettmer, F. Steiner, T. Scheper. Journal of applied polymer science. **131** (2014) 39989.

COMBINATION OF NANO/MICRO FIBERS FOR COLLECTION OF PARTICLE MATTER

Justinas Masionis^{1*}, Edvinas Krugly¹, Darius Ciuzas¹, Dainius Martuzevicius¹

¹ Faculty of Chemical Technology, Kaunas University of Technology, Kaunas, Lithuania

* corresponding author: justinas.masionis@ktu.lt

Introduction. Air pollution by particle matter (PM) creates a significant hazard to the environment and human health. Most dangerous particles are up to 2.5 μm in diameter [1]. The solution electrospinning method can produce nanofiber membranes capable of efficiently collecting fine particle matter PM2.5. However, the use of these filters is limited because of their fragile structure [2]. These disadvantages can be overcome by combining nanofibers with microfibers. Electrospun nano/microfiber filter possesses low-pressure drop while retaining high 99 % PM2.5 filtration efficiency [3]. Due to these advantages, it can be perspective as personal protective equipment.

Methods. A combination of solution and melt electrospinning was used. For the first technique, we prepared a solution of polyamide 6/6 dissolved in formic acid, and for the second, the filament of Vestamid L1723. Both electrospinning techniques were used to achieve the best results: simultaneously, melt-solution-melt, alternating between melt and melt + solution and alternating between melt and solution. Produced mats filtration efficiency and pressure drop were tested with Dekati's Electrical Low-Pressure Impactor (ELPI+) at 5.35 cm/s face velocity using NaCl aerosol particles. To investigate the effects of different electrospinning parameters on nano/microfiber structure SEM analysis was used.

Results and conclusion. The filtration efficiency of NaCl particles of 74-99 % was achieved. Pressure drop varied from 52 to 322 Pa. SEM images showed that fibers diameter varied from 0.02 to 45.6 μm , meaning that different layers of nano- and microfibers were successfully produced. Due to high filter air resistance, further research is needed to be competitive with conventional respirators.

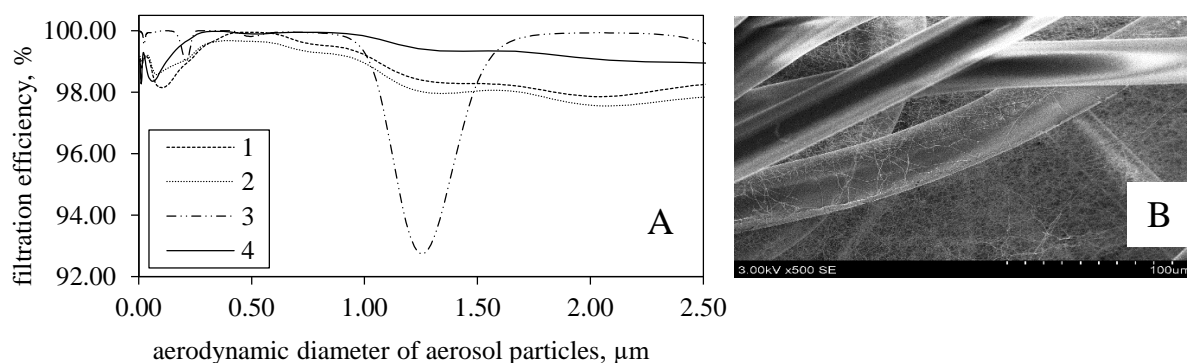

Fig. 1. A – The filtration efficiency of aerosol particles (1 – alternating between melt – melt + solution, 2 – melt – solution – melt, 3 – simultaneously, 4 – alternative respirator). B – SEM image of micro/nanofibers sample 1 at 500x magnification.

References

1. Jiaxin Cui a, et al. Flexible and transparent composite nanofibre membrane that was fabricated via a “green” electrospinning method for efficient particulate matter 2.5 capture. *Journal of Colloid and Interface Science*. 2021, 582, 506-514, doi: 10.1016/j.jcis.2020.08.075
2. Zhu, Miaomiao, et al. Electrospun Nanofibers Membranes for Effective Air Filtration. *Macromolecular Materials and Engineering*. 2017, 302(1), 1-27, doi: 10.1002/mame.201600353
3. Liu, Yongsheng, et al. Preparing micro/nano-fibrous filters for effective PM 2.5 under low filtration resistance. *Chemical Engineering Science*. 2020, 217, 115523, doi: 10.1016/j.ces.2020.115523

VANILLIN ACRYLATE-BASED POLYMERS WITH ANTIBACTERIAL ACTIVITY

Auksė Navaruckienė^{1*}, Justinas Jaras¹, Danguolė Bridžiuvienė², Vita Raudonienė², Jolita Ostrauskaitė¹

¹ Department of Polymer Chemistry and Technology, Kaunas University of Technology, Radvilenu Rd. 19, LT-50254 Kaunas, Lithuania;

² Biodeterioration Research Laboratory, Nature Research Center, Akademijos Str. 2, LT-08412 Vilnius, Lithuania;

* aukse.navaruckiene@ktu.lt

Photopolymerization is the rapid formation of cross-linked polymers from monomers under the influence of the light. Photopolymerization can be initiated by UV-, visible- and rarely by IR-light [1]. In the last years vanillin and its derivatives are starting to be used in polymer synthesis as their aromatic resin provides high rigidity and thermal stability of resulting polymers [2].

This work focuses on the comparison of the influence of the resin composition on photocuring kinetics of free-radical, thiol-Michael, and dual curing systems as well as on antibacterial properties of resulted polymers. Two vanillin derivatives, vanillin dimethacrylate (VDM) and vanillin diacrylate (VD), were used in photocurable systems with 1 mol of 1,3-benzenedithiol (BDT) or without it, using phenyl bis(2,4,6-trimethylbenzoyl) phosphine oxide (BAPO) as photoinitiator. The small amount of dichloromethane (DCM) were used in some resins.

It was determined that all components have a significant influence on photocuring kinetics and properties of the resulting polymers. The addition of thiol increased the photocuring rate but reduced the rigidity of the resulting polymers. The addition of solvent slowed down the photocuring rate and less rigid polymers were obtained. Vanillin acrylate- and vanillin dimethacrylate-based polymers showed a significant antibacterial activity against *Escherichia coli* and *Staphylococcus aureus* in direct contact and on medium (Table 1).

Table 1. Antibacterial activity characteristics of polymer film specimens

Polymer film	Escherichia coli			Staphylococcus aureus		
	Growth Inhibition Zone, mm	Log Reduction after 24 h	Percent Reduction after 24 h	Growth Inhibition Zone, mm	Log Reduction after 24 h	Percent Reduction after 24 h
1VD/1BDT/3BAPO	0	0	100	2.1±0.8	0	100
1VD/1BDT/3BAPO/DCM	0	0	100	2.0±0.0	0	100
1VD/3BAPO	1.0±0.7	0	100	2.1±0.8	0	100
1VDM/1BDT/3BAPO/DCM	0	1.98	98.96	0	0	100
Chitosan	2.0±0.7	0	100	2.5±0.5	0	100
Hydroxyethyl starch	0	1.25	94.42	0	2.85	99.86

Acknowledgements. This research was funded by the Research Council of Lithuania (project no. S-MIP-20-17), the EU ERDF, through the INTERREG BSR Programme, (ECOLABNET project #R077) and the European Social Fund under the measure no. 09.3.3-LMT-K712 "Development of Competences of Scientists, other Researchers and Students through Practical Research Activities".

References

1. X. Zhu, Q. Niu, Y. Xu, G. Wu, G. Li, J. Nie, G. Ma. *Photoch. Photobio. A* **353** (2018) 101-107.
2. J.F. Stanzione, J.P. Sadler, J.J. La Scala, K.H. Reno, R.P. Wool. *Green. Chem.* **14** (2012) 2346-2352.

EFFECT OF ESTERIFICATION AGENT AND SUBSTITUTION DEGREE ON HYDROPHOBICITY AND THERMAL PROPERTIES OF STARCH

Laura Peciulyte^{1*}, Ugne Naruseviciute¹, Ramune Rutkaite¹

¹ *Department of Polymer Chemistry and Technology, Kaunas University of Technology, Kaunas, Lithuania*

** laura.peciulyte@ktu.lt*

The use of biodegradable polymers represent a solution to the problems of contamination caused by conventional synthetic polymers. One of such polymers is starch, which occurs widely in nature and is the second largest biomass on earth after cellulose and one of the most abundant bio-renewable materials. However, the intermolecular forces and hydrogen bonds in starch granules prevent the processing of starch in the way typical to thermoplastic materials. By reducing those interactions, the thermal properties of starch could be changed. The aim of this study was to synthesize starch esters with controllable thermal properties by using different organic anhydrides and varying the degree of substitution (DS).

Potato starch was modified with acetic (Ac) and/or octenyl succinic (OSA) anhydrides and characterized by Fourier-transform infrared spectroscopy and scanning electron microscopy. The thermal properties of the modified starches were evaluated by thermogravimetry and differential scanning calorimetry. When starch was modified with octenyl succinic or acetic anhydride at low degree of substitution, DS being up to 0.62, the glass transition (T_g) temperature was not observed (Table 1) and destruction temperature (T_d) of derivatives decreased with increasing DS. T_g of starch acetate with high DS higher than 0.8 was detected in the interval of 162-167 °C and T_d was increasing with increasing DS. T_g was also observed for starches dual modified with both Ac and OSA even at low DS values, which was increasing with increasing DS_{Ac} . When DS_{Ac} was higher than 1.06 the T_g dependence on DS was no longer valid. Meanwhile T_g was affected by molecular weight of modified starch. The T_d of dual modified starch increased with increased DS_{Ac} .

Table 1. Thermal properties of modified starches

DS_{Ac}	DS_{OSA}	T_d , °C	T_g , °C
0	0	291	-
0	0.06	272	-
0.30	0	292	-
0.43	0	267	-
0.62	0	240	-
0.8	0	249	162
1.10	0	249	162
1.67	0	278	167
1.88	0	312	165
0.03	0.06	287	162
0.44	0.06	279	163
0.53	0.06	302	164
1.06	0.06	318	175
1.23	0.06	316	171
1.58	0.06	315	167
1.68	0.06	312	171

SYNTHESIS AND PROPERTIES OF CATIONIC CATECHOL BRUSH COPOLYMERS

Medeina Steponavičiūtė^{1*}, Vaidas Klimkevičius¹

¹ *Institute of Chemistry, Vilnius University, Vilnius, Lithuania*

* *e-mail: medeina.steponaviciute@chf.vu.lt*

Synthesis and application of bio-inspired polymeric materials have always been one of the main fields of materials science. In recent years, more and more attention has been given to mussel protein mimetic polymers containing catechol groups, known as the mussel-mimetic bioadhesives. These mussel-mimetic, polydopamine-containing polymers have been proven to be highly suitable for various applications in biomedicine such as biosensors, drug delivery, cancer cell imaging, medicine glue, hydrogel, and coatings [1]. Such extensive use of these biopolymers is due to their good antibacterial properties, complexation, and excellent adhesion to various surfaces and compounds under various environmental conditions [2]. In addition, they excel non-toxicity and biocompatibility [3].

Several different methods are used to obtain polymers with catechol moieties; however, the modification of preformed polymers by compounds carrying catechol groups remains supreme mainly due to the wide choice of starting polymer base and a wider possible choice of compounds suitable for the modification. Furthermore, this method gives materials with the catechol pendants along the entire length of polymer chains, and required catechol derivatives can be easily introduced on synthetic polymers by using simple synthetic strategies that allow straightforward functionalization [4]. Among synthetic polycations, poly(N,N-dimethylaminoethyl methacrylate) (pDMAEMA) is of great importance. Because of the reactivity of its amino groups, this polymer has much potential for facile modification reactions. Modification of pDMAEMA and its copolymers with catechol bearing substitutes, called quaternization, gives cationic catechol-containing polymers. Moreover, it possesses responsiveness to pH, temperature, and ionic strength, which gives unique properties to DMAEMA (co)polymers and their modified derivatives [5].

In this study, we demonstrated possibilities to synthesize well-defined gradient cationic catechol brush copolymers p(QDMAEMA-*co*-PEO₁₉MEMA) with DP close to 100 and Đ less than 1.18 and characterized their properties by ¹H NMR, FT-IR, UV-vis spectroscopy, and water contact angle measurements. For attachment of catechol moieties, DMAEMA units of the copolymers were quaternized with 2-chloro-3,4-dihydroxyacetophenone (CCDP). We also report the optimized quaternization procedure of DMAEMA units in the copolymers, enabling us to reach the degree of quaternization up to 100 %. Particular focus was directed to the kinetics of the RAFT copolymerization of DMAEMA and PEO macromonomer. Kinetics of RAFT copolymerization were studied by size exclusion chromatography (SEC) and ¹H NMR, which allowed calculating copolymerization rate and the evolution of copolymer composition during copolymerization. In addition, molecular weight M_n and dispersity Đ of the copolymers were determined by SEC with triple detection.

Acknowledgements. This project has received funding from European Social Fund (project No 09.3.3-LMT-K-712-19-0012) under grant agreement with the Research Council of Lithuania (LMTLT).

References

1. R. D. Balkenende, S. M. Winklera, P. B. Messersmith. *Eur. Polym. J.* **116** (2019) 134.
2. P. K. Forooshani., B. P. Lee. *J. Polym. Sci. Part A Polym. Chem.* **55** (2017) 9.
3. N. Patil, C. Jérôme, C. Detrembleur. *Prog. Polym. Sci.* **82** (2018) 34.
4. S. Moulay. *Polym. Rev.* **54** (2014) 436.
5. A. Muñoz-Bonilla, M. Fernández-García. *Prog. Polym. Sci.* **37** (2012) 281.

CHARACTERISTICS OF CEMENT SUPERPLASTICIZER BASED ON POLYMELAMINE SULPHONATE

Agnė Zdaniauskienė^{1*}, Asta Judžentienė

¹*Organic Chemistry Department, Center for Physical Sciences and Technology, Vilnius, Lithuania*

*E-mail: agne.zdaniauskiene@fmc.lt

Superplasticizers (SPs) are effective organic additives for reducing water content, giving homogeneity and non-segregation, lowering porosity, increasing mechanical strength and workability, and achieving sufficient fluidity and good plasticity of cement [1–3]. SPs possibly decompose into relatively small molecular weight polymers over the long term, and these organic substances may be leached into groundwater from cementitious materials.

According to the market analysts, the sulfonated melamine formaldehyde (PMS) condensates segment held a 31% share of the overall market, which is highest among other types of concrete SPs [4].

Detailed chemical composition of the cement superplasticizer Peramin® SMF10 based on PMS has been done by Wavelength dispersive X-Ray Fluorescence (WD-XRF) spectroscopic method. The above analysis has shown that the product contains 99.824% of the polymer. Additionally, minor amounts of P₂O₅, ZnO, Na₂O, SiO₂, CaO, Cl⁻, Al₂O₃, and Fe₂O₃ have been determined.

Other physicochemical properties of the superplasticizer were evaluated by thermogravimetric analysis at a range of 30 – 800 °C. The polymer is stable thermally up to 270 °C.

In order to investigate the rate of alkaline degradation of the SP in different aqueous solutions, spectroscopic analyses (Raman and UV/Vis) have been applied.

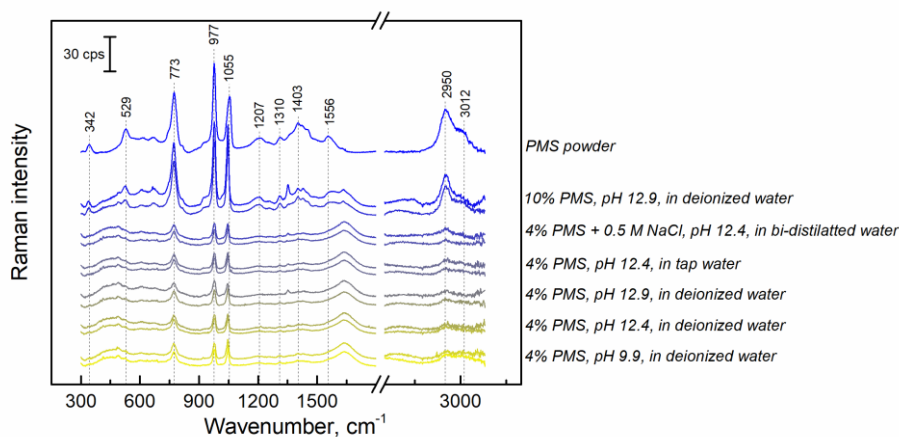

Fig. 1. Raman spectra of different PMS hydrolytic solutions during the time. The upper curves indicate solutions after 3 months, the lower ones –just made samples.

Acknowledgments. For financial support of European Joint Programme on Radioactive Waste Management, **EURAD CORI** 2019-2024 (Horizon 2020), to **Peramin AB** (Upplands Väsby, Sweden) for providing product Peramin® SMF10 (5kg) free of charge.

References

1. M. Y. A. Mollah, W. J. Adams, R. Schennach, and D. L. Cocks. *Advances in Cement Research* **12** (2000) 4
2. V. S. Ramachandran, V. M. Malhotra, C. Jolicoeur, and N. Spiratos. *Superplasticizers: properties and applications in concrete*. Canada: N. p., 1998. Web.
3. S. M. Lahalhi, M. Absl-Halabi, A. M. Ali. *Cement and Concrete Research* **18** (1988) 4
4. L. Wood. *Concrete Superplasticizers Market - Forecast (2020 - 2025)*. ResearchAndMarkets.com (2020)