

ADVANCED ALGORITHM FOR MPPT CONTROL OF PHOTOVOLTAIC SYSTEMS

C. Liu, B. Wu and R. Cheung

Department of Electrical & Computer Engineering, Ryerson University, Toronto, Ontario, Canada M5B 2K3

ABSTRACT

Photovoltaic (PV) offers an environmentally friendly source of electricity, which is however still relatively costly today. The maximum power point tracking (MPPT) of the PV output for all sunshine conditions is a key to keep the output power per unit cost low for successful PV applications. This paper proposes a new method for the MPPT control of PV systems, which uses one estimate process for every two perturb processes in search for the maximum PV output. In this estimate-perturb-perturb (EPP) method, the perturb process conducts the search over the highly nonlinear PV characteristic, and the estimate process compensates the perturb process for irradiance-changing conditions. The EPP method significantly improves the tracking accuracy and speed of the MPPT control compared to available methods. This paper details the analysis of the EPP method.

INTRODUCTION

Photovoltaic (PV) offers an environmentally friendly source of electricity, of which the fuel is sunshine, a renewable energy. To date, this way of electricity generation, however, has been relatively costly. Very often, the success of a PV application depends on whether the power electronics device can extract sufficiently high power from the PV arrays to keep overall output power per unit cost low. The maximum power point tracking (MPPT) of the PV

output for all sunshine conditions, therefore, becomes a key control in the device operation for successful PV applications. The MPPT control is, in general, challenging, because the sunshine condition that determines the amount of sun energy into the PV array may change all the time, and the current-voltage characteristic of PV arrays is highly nonlinear.

A PV system for the grid-connected applications is typically composed of five main components: 1) a PV array that converts solar energy to electric energy, 2) a dc-dc converter that converts low dc voltages produced by the PV arrays to a high dc voltage, 3) an inverter that converts the high dc voltage to a single- or three-phase ac voltage, 4) a digital controller that controls the converter operation with MPPT capability, and 5) a ac filter that absorbs voltage/current harmonics generated by the inverter.

The main technical requirements in developing a practical PV system include a) an optimal control that can extract the maximum output power from the PV arrays under all operating and weather conditions, and b) a high performance-to-cost ratio to facilitate commercialization of developed PV technologies. Since the PV array has a highly nonlinear characteristic, and its performance changes with operating conditions such as insolation or ambient temperature, it is technically challenging to develop a PV system that can meet these technical requirements.

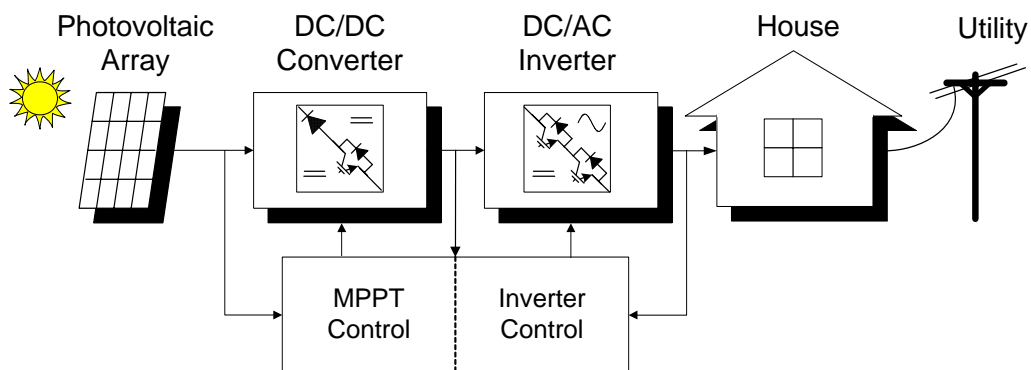

Fig. 1. Block diagram of Photovoltaic power system

This paper proposes a new method for the MPPT control of PV systems. This method uses one estimate process for every two perturb processes in search of the maximum PV output. In this estimate-perturb-perturb (EPP) method, the perturb process conducts the search over a highly nonlinear PV characteristic, and the estimate process compensates the perturb process for irradiance-changing conditions. This paper illustrates that EPP method can significantly improve the tracking accuracy and speed of the MPPT control.

EXISTING MPPT METHODS

To date, a number of MPPT algorithms have been proposed in the literature, including perturb-and-observe method (K. Chomsuwan et al., 1995; W. Xiao et al., 2004), open- and short-circuit method (T. Noguchi et al., 2002), incremental conductance algorithm (C. Hua, 1998), and fuzzy logic (N. Patcharaprakiti et al., 2006) and artificial neural network (A. Torres et al., 1998).

Perturb-and-observe (P&O) Method

The perturb-and-observe method, also known as perturbation method, is the most commonly used MPPT algorithm in commercial PV products (K. Chomsuwan et al., 1995; W. Xiao et al., 2004). This is essentially a "trial and error" method. The PV controller increases the reference for the inverter output power by a small amount, and then detects the actual output power. If the output power is indeed increased, it will increase again until the output power starts to decrease, at which the controller decreases the reference to avoid collapse of the PV output due to the highly non-linear PV characteristic.

Although the P&O algorithm is easy to implement, it has a number of problems, including 1) the PV system cannot always operate at the maximum power point due to the slow trial and error process, and thus the solar energy from the PV arrays are not fully utilized; 2) the PV system may always operate in an oscillating mode even with a steady-state sunshine condition, leading to fluctuating inverter output; and 3) the operation of the PV system may fail to track the maximum power point due to the sudden changes in sunshine.

Open- and Short-circuit Method

The open- and short-circuit current method for MPPT control is based on measured terminal voltage and current of PV arrays (T. Noguchi et al., 2002). By measuring the open-circuit voltage or short-circuit current in real-time, the maximum power point of the PV array can be estimated with the predefined PV current-voltage curves. This method features a relatively fast response, and do not cause oscillations in steady state. However, this method

cannot always produce the maximum power available from PV arrays due to the use of the predefined PV curves that often cannot effectively reflect the real-time situation due to PV nonlinear characteristics and weather conditions. Also, the online measurement of open-circuit voltage or short-circuit current causes a reduction in output.

Incremental Conductance Algorithm

The main task of the incremental conductance algorithm is to find the derivative of PV output power with respect to its output voltage, that is dP/dV (C. Hua et al., 1998). The maximum PV output power can be achieved when its dP/dV approaches zero. The controller calculates dP/dV based on measured PV incremental output power and voltage. If dP/dV is not close zero, the controller will adjust the PV voltage step by step until dP/dV approaches zero, at which the PV array reaches its maximum output. The main advantage of this algorithm over the P&O method is its fast power tracking process. However, it has the disadvantage of possible output instability due to the use of derivative algorithm. Also the differentiation process under low levels of insolation becomes difficult and results are unsatisfactory.

Fuzzy Logic and Other Algorithms

Since the PV array exhibits a non-linear current-voltage or power-voltage characteristic, its maximum power point varies with the insolation and temperature. Some algorithms such as fuzzy logic or artificial neural network control with non-linear and adaptive in nature fit the PV control. By knowledge-based fuzzy rules, fuzzy control can track maximum power point (N. Patcharaprakiti et al., 2006). A neural network control operates like a black box model, requiring no detailed information about the PV system. After learning relation between maximum power point voltage and open circuit voltage or insolation and temperature, the neural network control can track the maximum power point online. The disadvantage of these controls is the high cost of implementation owing to complex algorithms that usually need a DSP as their computing platform.

THE PRINCIPLE OF P&O, MP&O, EPP METHODS

P&O method

Perturb-and-observe (P&O) method is dominantly used in practical PV systems for the MPPT control due to its simple implementation, high reliability, and tracking efficiency.

Fig. 2 shows the flow chart of the P&O method. The present power $P(k)$ is calculated with the present values of PV voltage $V(k)$ and current $I(k)$, and is

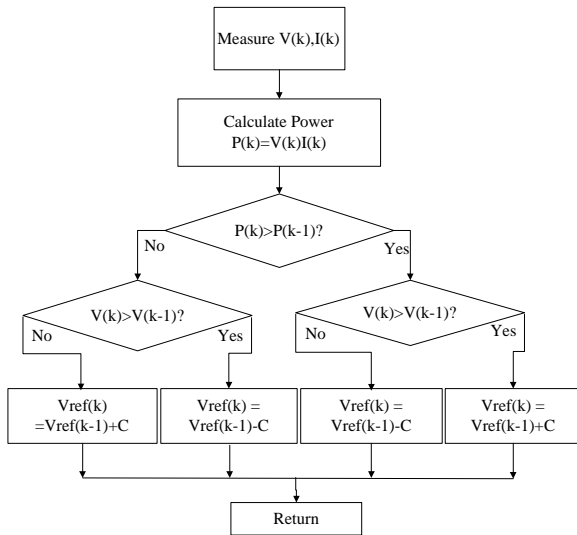

Fig. 2. P&O method flow chart

compared with the previous power $P(k-1)$. If the power increases, keep the next voltage change in the same direction as the previous change. Otherwise, change the voltage in the opposite direction as the previous one.

MP&O method

It is known that the P&O method exhibits erratic behavior under rapidly changing irradiance level that causes incorrect or slow maximum power tracking. Because the P&O method is a type of hill-climbing methods for higher PV power output, the changing irradiance alters the shape of hill that often leads the climbing to wrong directions.

The Modified P&O (MP&O) method was proposed to solve this problem by decoupling the PV power fluctuations caused by hill-climbing process from those caused by irradiance changing (D. P. Hohm et al., 2003). This method adds an irradiance-changing

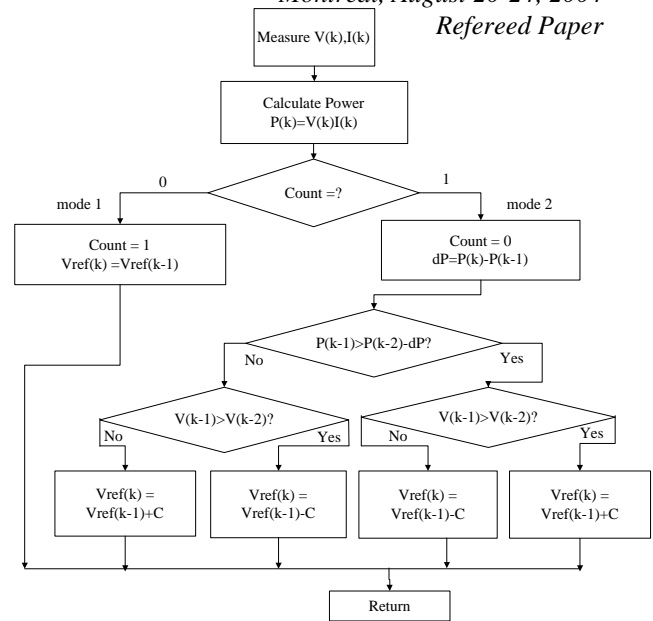

Fig. 3. MP&O method flow chart

estimate process in every perturb process to measure the amount of power change caused by the change of atmospheric condition, and then compensates it in the following perturb process.

Fig. 3 shows the flow chart of the MP&O method. There are two operation modes named: Mode 1 for estimate process; and Mode 2 for perturb process. Mode 1 measures the power variation due to the previous voltage change and atmosphere change, and keeps the PV voltage constant for the next control period. Mode 2 measures the power variation and determines the new PV voltage based on the present and the previous power variations.

Because the estimate process of Mode 1 stops tracking maximum power point by keeping the PV voltage constant, the tracking speed of MP&O method is only half of the conventional P&O

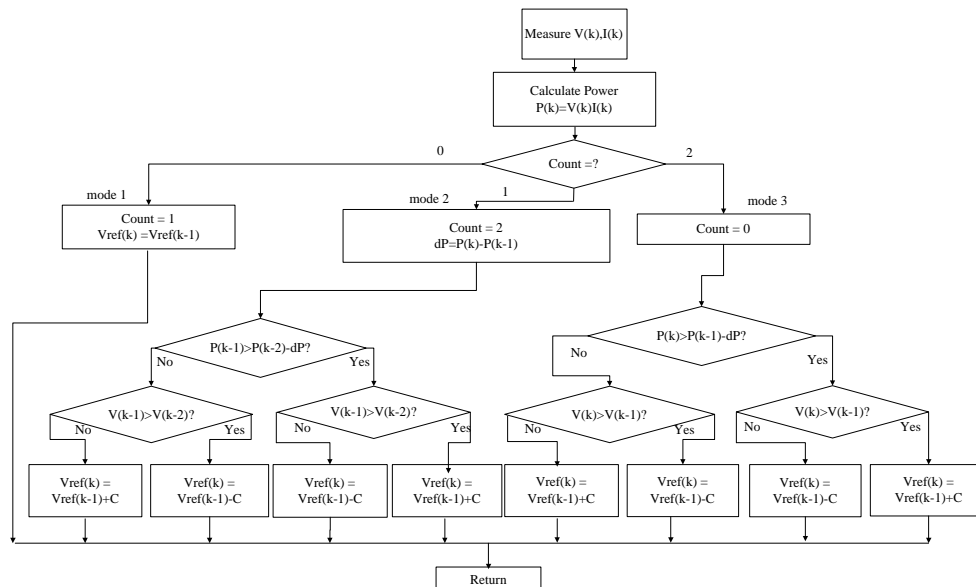

Fig. 4. Proposed EPP method flow chart

method.

Proposed EPP method

This paper proposes a new method to improve the tracking speed of the MP&O. This method is named the EPP that uses *one estimate* mode between every *two perturb* modes. Fig. 4 shows the flow chart for the proposed EPP method. The operations of the estimate mode and the perturb mode in the EPP method are the same as those of the MP&O method explained above.

When compared with the P&O method, the EPP method proposed in this paper, with an addition of the estimate mode, considers the changing irradiance in the control that significantly improves the MPPT performance. When compared with the MP&O method, the EPP method that uses one estimate mode for every two perturb modes increases significantly the tracking speed of the MPPT control, without reduction of the tracking accuracy.

Fig. 5 shows the time sequences for the P&O method, the MP&O method, and the EPP method. Comparing with the MP&O method, the EPP method has a tracking speed of 1.5 times faster but has the same delay time between the estimate process and the perturb process. Therefore the EPP method has obvious advantages over the MP&O method.

SIMULATION

Grid connected photovoltaic System

Fig. 6 shows the grid-connected PV system used in the simulation. The PV system includes a PV array, a converter, and an inverter. The converter is a current-fed push-pull dc/dc converter that is used to boost the PV voltage of around 100V dc to 200V dc and to

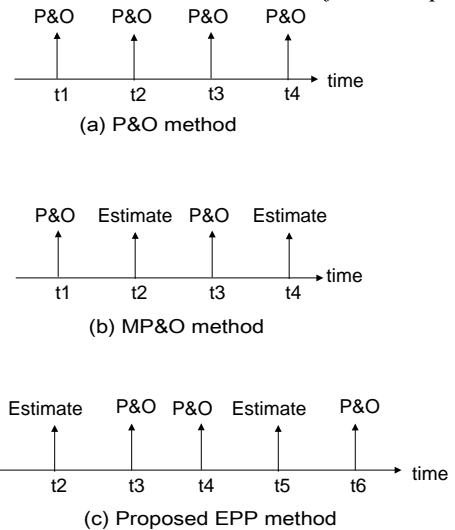

Fig. 5. The time sequence of three P&O methods

provide electrical isolation between the input from the PV array and the output to the inverter. The inverter is a single-phase H-bridge inverter that converts 200V dc voltage to 120 V ac line voltage.

Among many dc/dc converter topologies, the current-fed push-pull topology is selected because its low input current ripples, which is important for MPPT control of PV panel. The dc/dc converter is controlled by the MPPT control shown in Fig.6. The PV voltage v_{pv} and current i_{pv} are measured and used to compute the reference voltage v_{pv}^* according MPPT flow charts given in Fig. 2, 3 or 4. The dc/dc converter is controlled in the current mode based on the computed voltage reference.

The inverter is controlled to keep its input voltage V_{dc} at around 200V and its output at unity power factor on utility side. The inverter operates in the current mode that keep its output current sinusoidal.

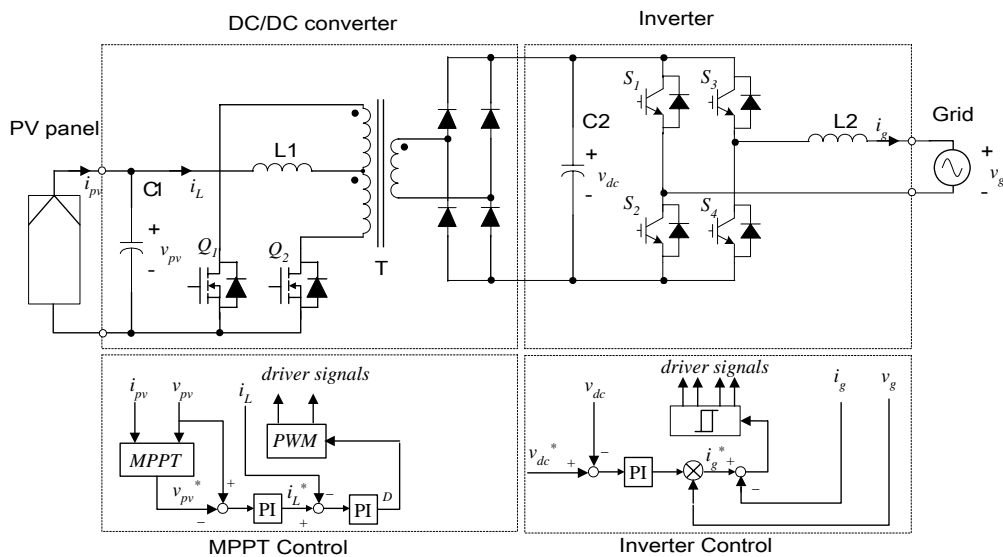

Fig. 6. The photovoltaic power system for simulation

The PV array used in the simulation is 20 Solarex MSX60 60W panels connected in 5×4 matrix. The open-circuit voltage of the PV array is 105V, and the short-circuit current is 14.8A. The maximum power point of the PV array is at 85.5V, 14A, and 1198 W under 1000W/m² insolation at 25°C. The utility is simulated as a 120V, 60 Hz voltage source.

The parameters of the circuit used in simulation are given in Table. I.

Table. I
 Main circuit parameters

Input capacitor C1:	100 uF
Boost inductor L1:	2 mH
Transformer T:	3 : 2
Dc link capacitor C2:	4700 uF
Grid inductor L2:	2mH

Three MPPT methods are simulated in the PV system shown in Fig.6 for different atmospheric conditions. The MPPT control period is 2.5 ms, and the reference voltage v_{pv}^* changes in 0.25 V steps. The carrier frequency of DC/DC converter is 10 kHz, and switching frequency of inverter is around 20 kHz.

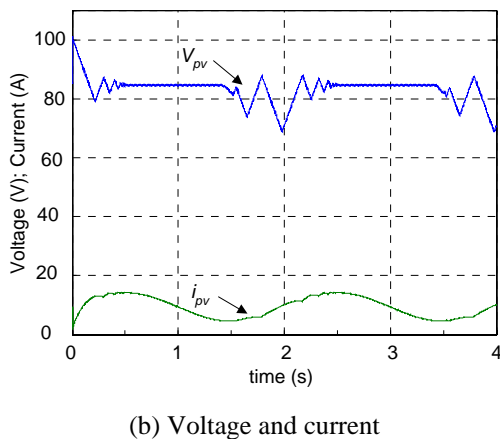
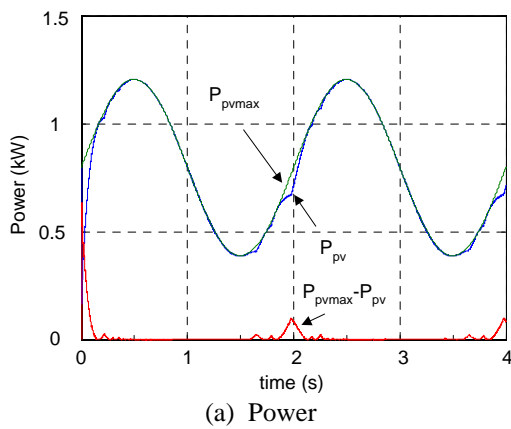

Fig. 7. The PV output of P&O method under sinusoidal changing irradiance

Rapidly changing irradiance conditions

Simulations are carried on when the irradiance on PV array varies from 333 W/m² to 1000 W/m² in 0.5Hz waveform. Fig. 7 shows the PV output power, voltage and current using the P&O control. Fig. 7(a) shows the maximum PV internal power P_{pvmax} , the actual PV output power P_{pv} and tracking error $P_{pvmax} - P_{pv}$. This figure shows that the initial tracking error is reduced to zero in 0.15s by the P&O control.

When the irradiance decreases, the P&O method tracks the maximum power point well and the tracking error is nearly zero. However, when the irradiance increases, the P&O control does not track the maximum power point well, and the maximum tracking error is nearly 100W that is around 8% of the full power. Fig. 7(b) shows that when the irradiance increases, the PV voltage and current cannot track the maximum power point.

Fig. 8 shows the PV output power, voltage and current for the MP&O control. This control tracks the maximum power point very well with the steady tracking error of less than 1W.

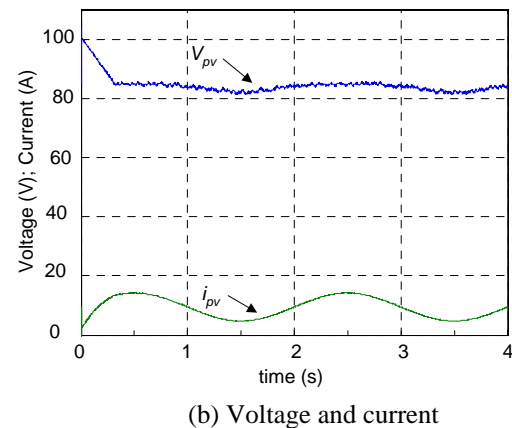
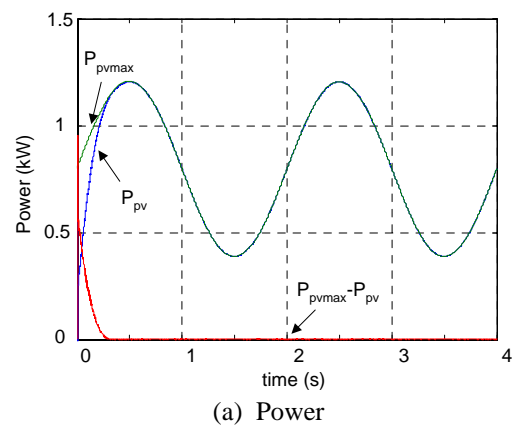
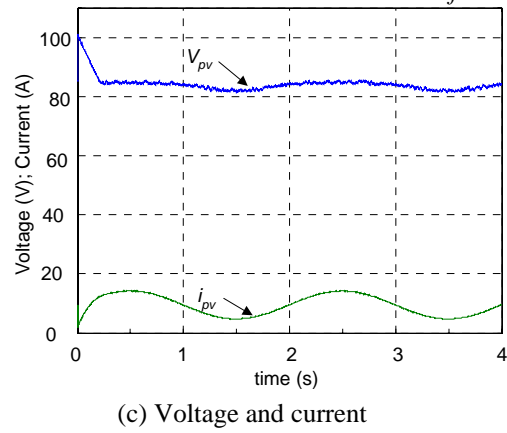
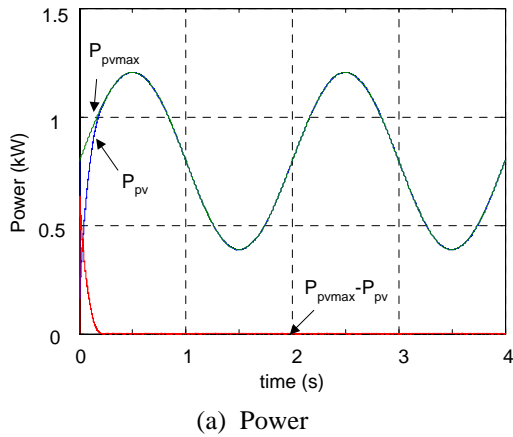

Fig. 8. The PV output of MP&O method under sinusoidal changing irradiance



(a) Power (c) Voltage and current
 Fig. 9. The PV output of proposed EPP method under sinusoidal changing irradiance

Fig. 9 shows the PV output power, voltage and current for the EPP control proposed in this paper. This figure shows the waveforms that are similar to those of Fig. 8. Therefore the proposed EPP control has the similar maximum power tracking performance as the P&O control, both with a steady state tracking error of less than 1W.

Initial tracking error

The response time of the maximum PV power tracking due to a step irradiance input reflects the tracking speed of the MPPT method. Fig. 10 shows that PV power tracking waveforms for three MPPT methods. Curve (i) is the maximum PV internal power. Curves (ii), (iii), and (iv) are actual PV power under the P&O control, the MP&O control, and the EPP control proposed in this paper, respectively. Among these three methods, the P&O control is the quickest one with the tracking time of only 0.15s. The MP&O control is the slowest one that needs doubled tracking time of 0.3s. The proposed EPP control needs 0.2s tracking time, quicker than the MP&O control but slower than the P&O control.

DC/DC converter control performance

Fig. 11 shows the closed-loop control performance of

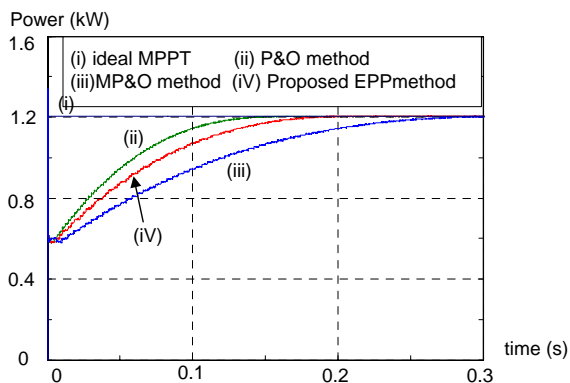
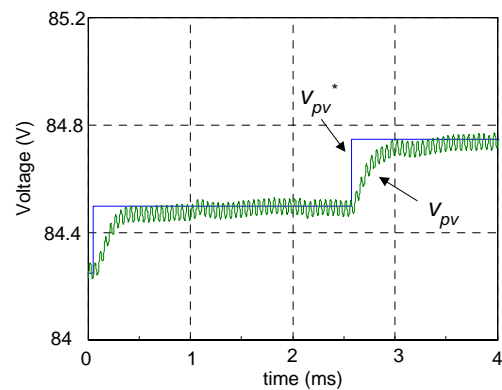
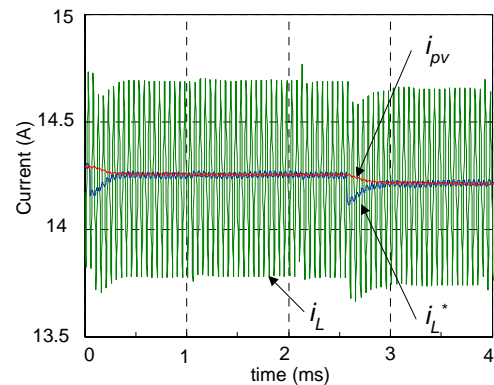

Fig. 10. The PV power of three MPPT methods under step changing irradiance



(a) PV Voltage and reference



(b) Converter current, reference and PV current

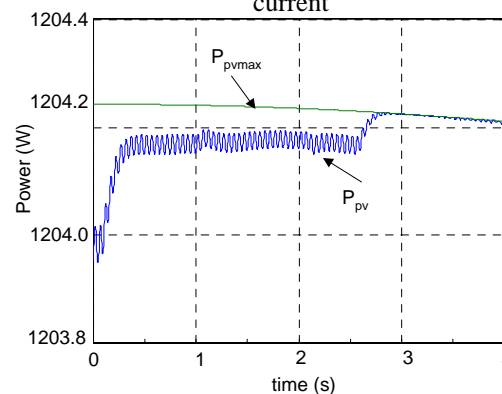

(c) Power

Fig. 11. The voltage, current and power of DC/DC converter under proposed EPP method

the dc/dc converter. Fig. 11(a) shows the PV reference voltage v_{pv}^* and the PV output voltage v_{pv} . The step response time of the PV output voltage is less than 1ms. Fig. 11(b) shows the inductor current in converter i_L , its reference i_L^* and PV current i_{pv} . The step response time of i_L is less than 0.2ms. This figure shows that although there is a 1A ripple in converter inductor current, the ripple of PV current is pretty small because of filtered by the capacitor C1.

Fig. 11(c) shows the maximum PV internal power and the actual PV output power. This figure shows that PV power is close to the maximum internal power, the tracking error of less than 1W, and the power ripple caused by the ripple voltage of converter is also small.

Inverter control performance

Fig. 12 shows the inverter input voltage and output current and the line voltage. This figure shows that the input voltage is controlled at around 200V, and the total harmonic distortion (THD) of the output current is only 4.7%, and it is in phase with the line voltage.

CONCLUSION

This paper has proposed a new method for the MPPT control of PV systems. This method uses one estimate process for every two perturb processes in

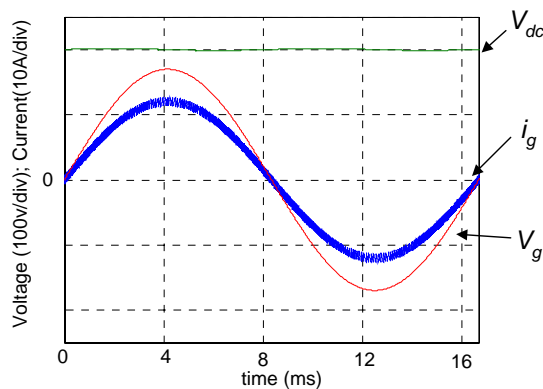

Fig. 12. The voltage and current of inverter under proposed EPP method

search of the maximum PV output for all sunshine conditions. This paper has illustrated that this method can provide accurate and reliable maximum power tracking performance even under a rapidly changing irradiance condition. Also this paper has demonstrated that the tracking speed of the proposed

method is significantly improved compared to the modified P&O method. A grid-connected PV system using three MPPT controls is simulated and compared. Simulation results have verified the tracking accuracy and speed of proposed MPPT control.

REFERENCES

- A. Torres, F. Antunes, F. Reis, "An artificial neural network-based real time maximum power tracking controller for connecting a PV system to the grid," in 1998 Proceeding, IEEE Annual Conf. Industrial Electronics Society (IECON'98), vol.1, pp. 554-558, Aug.-Sept. 1998
- C. Hua, C. Shen, "Comparative study of peak power tracking techniques for solar storage systems," in 1998 Proc. IEEE Applied Power Electronics Conf. and Expo., (APEC'98), pp. 697-685, 1998.
- D. P. Hohm and M. E. Ropp, "Comparative Study of Maximum Power Point Tracking Algorithms", progress in photovoltaics: research and applications, 2003, v11, pp:47-c62, 2003
- K. Chomsuwan, P. Prisuwan, et al., "Photovoltaic grid-connected inverter using two-switch buck-boost converter," in Conf. Rec. 2002 IEEE Photovoltaic Specialists Conf., pp. 1527-1530, May 2002.
- N. Patcharaprakiti, S. Premrudeepreechacharn, "Maximum power point tracking using adaptive fuzzy logic control for grid-connected photovoltaic system," presented at the IEEE Power Engineering Society Winter Meeting, vol.1, pp. 372-377, Jan. 2002.
- T. Noguchi, S. Togashi, et al., "Short-current pulse-based maximum-power-point tracking method for multiple photovoltaic- and-converter module system," IEEE Trans. Ind. Electron., vol. 49, pp. 217-223, Feb. 2002.
- W. Xiao, W.G. Dunford, "A modified adaptive hill climbing MPPT method for photovoltaic power systems," in Conf. Rec. 2004 IEEE Annu. Power Electronics Specialists Conf.(PESC'04), vol.3, pp. 1957-1963, Jun. 2004.