

# WOOD CRATE design manual

AGRICULTURAL HANDBOOK NO. 252 • U.S. DEPARTMENT OF AGRICULTURE • FOREST SERVICE

# WOOD CRATE

## *Design Manual*

By L. O. ANDERSON, Engineer, and T. B. HEEBINK, Engineer

FOREST PRODUCTS LABORATORY

(Maintained at Madison, Wis., in  
cooperation with the University of  
Wisconsin)

AGRICULTURE HANDBOOK NO. 252  
FOREST SERVICE

FEBRUARY 1964  
U.S. DEPARTMENT OF AGRICULTURE

## CONTENTS

	<i>Page</i>		<i>Page</i>
Introduction.....	1	Light-duty open crates.....	59
Factors that affect crate design.....	2	Skid assemblies.....	68
Contents.....	2	Skid sizes.....	68
Destination and method of transit.....	2	Floorboard sizes.....	73
Handling hazards.....	2	Diagonal bracing.....	73
Storage conditions.....	4	Assembly.....	73
Costs.....	4	Testing crates.....	73
Materials for crates.....	5	Superimposed-load tests.....	74
Wood and wood-base materials.....	5	Handling tests.....	76
Fastenings.....	13	Drop and impact tests.....	78
Designing crates.....	23	Appendix I. Panel member sizes.....	80
Importance of diagonals.....	24	Appendix II. Details of shipping.....	120
Design principles.....	24	Marking.....	120
Designing the crate base.....	29	Packing lists.....	120
Designing the top.....	31	Shipping loss prevention.....	121
Sheathed crates.....	32	Export shipping.....	121
Military type sheathed crates.....	32	Anchoring crates to ship surfaces.....	121
Limited-military sheathed crates.....	45	Carloading crates.....	121
Light-duty sheathed crates.....	46	Shipping losses and insurance.....	123
Open crates.....	50	Tare weight of crates.....	123
Military type open crates.....	50	Appendix III. Glossary.....	125
Limited-military type open crates.....	53	Index.....	129

## ACKNOWLEDGMENT

In preparing this publication, the authors have been privileged to draw on much of the research of the late C. A. Plaskett, the late T. A. Carlson, and H. J. Kuelling, as well as a number of other members of the Forest Products Laboratory and various Defense Agencies. The number of these contributors is so great that individual acknowledgment is impractical.

## INTRODUCTION

The packaging industry consumes 15 to 20 percent of each year's timber cut, in the form of lumber, plywood, veneer, container fiberboard, composite materials such as paper overlaid veneer, and papers of various types. Because of this continued heavy use of wood, the Forest Products Laboratory, U.S. Forest Service, has always devoted much research to packaging. Much of this research has been conducted over the years in cooperation with the Air Force, the Army Corps of Engineers and Ordnance Corps, other agencies of the Defense Department, and several industrial firms.

Of principal concern are the fundamental principles of design and the relationships of various details in the construction of containers that are balanced in strength. Special testing machines and methods of testing have been developed. From this research, supplemented by study and observation of shipping containers in service, has come much information of value to packaging engineers.

The growth of American industry has generated great needs for containers of all kinds, from colorful wraps for retail merchandise to workhorse containers for the worldwide shipment of machines and equipment of any size, shape, and weight. Among these containers, the wood crate is one of the most important used for shipping and is perhaps the most adaptable to the application of engineering principles in design. Crates are generally made of wood (or a wood-base material) because it is strong and rigid, comparatively light in weight, inexpensive, easily formed into a multitude of sizes and designs, and adaptable to a variety of conditions of use.

A wood crate is a structural framework of members fastened together to form a rigid enclosure, which will protect the contents during shipping and storage. This enclosure is usually of rectangular outline and may or may not be sheathed. A crate differs from a nailed wood box in that the framework of members in sides and ends provides the basic strength (fig. 1), whereas a box must rely for its strength solely on the boards of the sides, ends, top, and bottom. This framework can be considered to be similar to a type of truss used in bridge construction. It is designed to absorb most of the stresses imposed by handling and stacking.

Notable among the findings and developments of the Forest Products Laboratory is the evolution

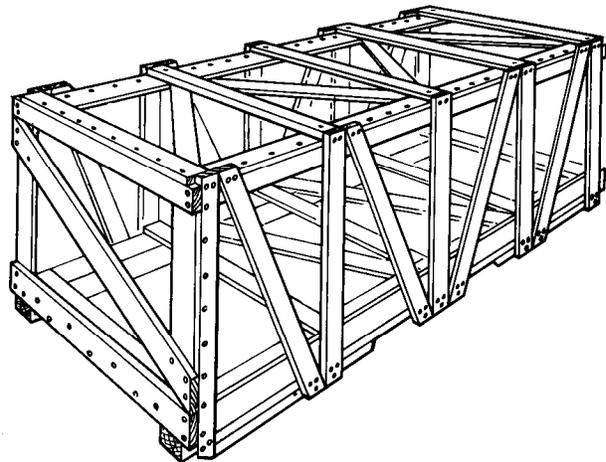

M-120691

Figure 1.—Typical open crate.

of crate design criteria for virtually any type of machine or other industrial product. These criteria are based on the following considerations:

1. A crate must be strong enough to protect its contents from the hazards of shipping and storage.
2. The lumber and other materials used to build the crate must be of suitable quality and dimensions.
3. A crate must be as light in weight as shipping hazards and the inherent strength properties of the materials permit.
4. It must require a minimum of shipping space.

With design criteria based on these considerations, the effective engineering of crates for specific purposes becomes possible. This handbook presents information of a general nature applicable to the design of most types of crates and the solution of crating problems. It is not intended to be a specification; however, in order to clarify design and construction of crates, a number of crate designs are included to aid the designer in his specific problem. It includes all data required for the design of crates, such as allowable working stresses for the various species of wood and the method of determining fastening requirements.

The advantages gained from good crate design are many. The shipper gains from better protection of his products and from lower shipping costs for lighter weight and lower space requirements. The carrier gains from lower liability costs. The consumer gains from the lower prices made possible for the goods shipped, and the Nation benefits from the efficient use of raw materials.

## FACTORS THAT AFFECT CRATE DESIGN

The selection of a crate depends on, in general order of importance, contents, destination, method of transit, handling hazards, storage conditions, and costs. These factors overlap, but each will be outlined separately to aid the designer or shipper in selecting the proper crate.

### CONTENTS

The nature of the item being crated is of fundamental importance in the selection of a shipping crate. If the item is ruggedly constructed, such as an axle assembly for a large truck, it has probably been prepared to resist the weather. Hence, an open crate would be more economical for this use than a closed one. While such an item could withstand a considerable amount of handling without damage, it would be easier to handle and store if it were crated.

Items less rugged or requiring protection from the weather would be shipped in fully sheathed crates. In all cases, however, the crate must be sturdy enough to (1) provide ample anchorage for the item, (2) resist rough handling, and (3) withstand superimposed loads.

Disassembly or partial disassembly often allows the use of smaller crates. However, the shipper should consider the reassembly necessary at destination. If he is shipping to his own distributor, the cost of reassembly can be compared with the savings made by the use of smaller crates. Unless the customer or distributor is equipped and willing to reassemble, it may be wise to ship the article completely assembled.

The type of base with which the item is equipped should also be considered. Certain items may be adaptable to the use of a crate with a sill-type base, but the majority are best suited to a skid-type base. The latter include equipment having a flat base with a distributed load or a base of the leg, single or double column, end frame, or pedestal type.

### DESTINATION AND METHOD OF TRANSIT

The destination often automatically determines the style of crate. In surface shipment overseas the crate might either be placed in the hold of a ship or on the deck. For easy passage of a crate through the average hatchway and into the hold, the outside dimensions should not exceed 41 feet in length, 9 feet in width, and 7 feet in height. Any crate larger than this will likely be placed on

the deck. A sheathed crate with a waterproof top is advisable for shipment on deck. Since smaller crates are not always placed in the hold, it would be logical to select a sheathed crate for most items that are destined for foreign ports.

Ordinarily there is a maximum size for rail shipment. This limit is to assure proper clearance of crates on a flatcar going through tunnels, under bridges, and around curves. However, size limitations may change, and a thorough check should be made with the transportation agencies involved before unusually large crates are shipped.

Consider if trucks may be used or short- or long-distance hauling. For truck transportation within the country only a basic framework may be needed to conveniently handle the item. Shipment of material by airfreight is becoming more practical for certain high-value items. Because these are usually of small or moderate size and receive preferential handling, they require only a light crate or a skid base.

To design a crate capable of resisting the most severe of the many hazards to be encountered in transit would ordinarily result in overdesign. It would be costly, and justifiable only on rare occasions. However, a general idea of transit conditions will usually convince the shipper that none of the generally accepted principles of crate design should be overlooked.

### HANDLING HAZARDS

Crates may be handled in a variety of ways, but the most important from the standpoint of design are end slinging, forklift handling, and grabhook lifting. Unless provisions are made for these types of handling, damage similar to that caused by the grabhook in figure 2 will likely occur.

Other stresses are placed on crates during shipment. Crates may be moved by pushing or skidding. Humping of freight cars can place racking stresses on crates and cause failure similar to that shown in figure 3 unless crates are designed and constructed properly. The vibration of railroad cars may cause failure of fastenings or loosening of blocking and bracing. Transportation by motor truck also involves more shipping hazards than are apparent. Loads are often not secured to the truck bed, and containers are subjected to vertical movements. End or side impacts and accidental dropping of one end of the crate are other hazards during handling that must be considered.

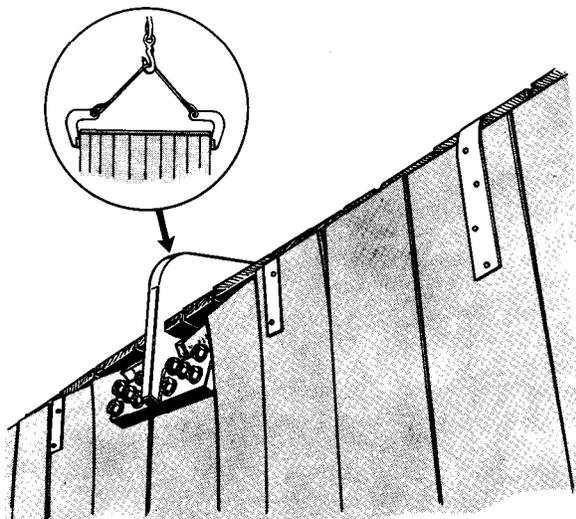

M-119659

Figure 2.—Crate damage caused by a grabhook when there was insufficient joist support in the top of the crate.

The crushing stresses of slings or grabhooks are resisted by the joists or other members in the top. Racking stresses from end thrusts or humping are resisted by the diagonals in lumber-sheathed crates and by the plywood in plywood-sheathed crates. Correct nailing of the crate panels as they are fabricated and using enough fastenings in assembling panels into a crate will further insure adequate strength to resist vibration and other stresses.

The handling of crates in foreign ports usually depends largely on the mechanical equipment available for unloading. Crates are often placed aboard small lighters with the ship's gear and unloaded at the dock site by a variety of methods. The crate designer should consider a design with a larger factor of safety to allow for such additional hazards.

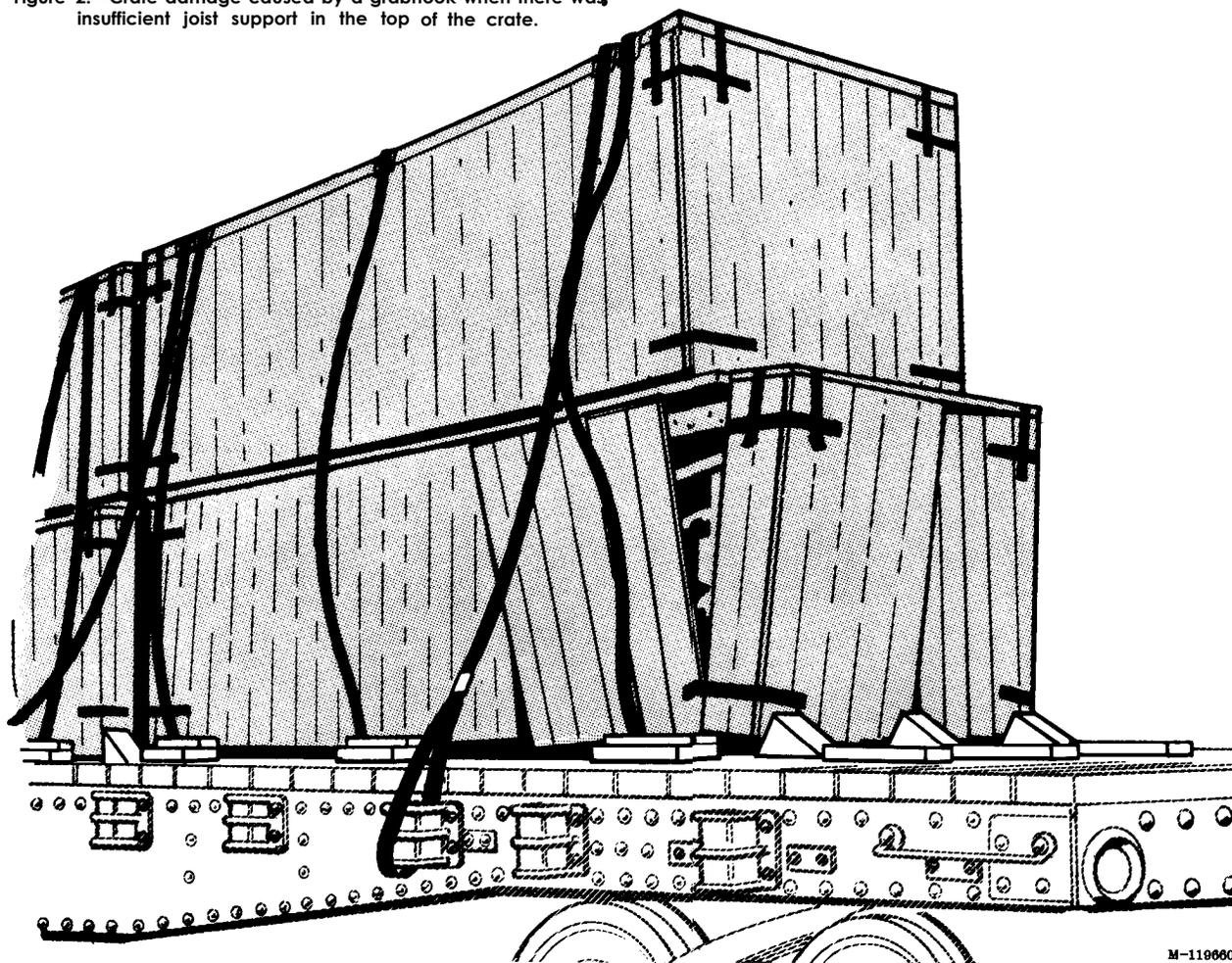

M-119660

Figure 3.—Failure of crate on railway car. Crate did not have racking resistance or the capacity to carry top loads under these shipping conditions.

## STORAGE CONDITIONS

A crate that will be transported in a covered carrier and either unpacked immediately upon arrival or placed in a warehouse does not require sheathing for protection, and an open crate might be selected. If the shipment is stored outdoors or exposed for a long time to the weather, the sheathed crate is a logical selection.

All crates, open or sheathed, should be capable of withstanding top loads. When top loading of crates is not considered in design, failure or excessive deflection may occur and result in damaged contents. Under most conditions, crates of like size and contents will be placed one atop another in warehouse or outdoor storage. This is called like-on-like stacking. The sides and ends of the lower crates support the load, and little stress is carried by the top panel. For this reason it is logical to reduce the requirements for tops of sheathed crates. Crate tops are stressed when smaller containers are superimposed. Only like-on-like stacking is considered with open crates. They are usually not designed for top loading with smaller containers.

## COSTS

The selection of the proper type of crate may gain a saving in both construction and shipping costs. An open crate costs less than a sheathed crate. It generally involves less material, lower construction costs, and a lower shipping cost because of less weight and cubic displacement.

The amount of lumber saved by using open crates rather than fully sheathed crates varies somewhat with the type of crate selected. For light and medium loads, the open crate uses a minimum of material and the saving is substantial. For heavy loads, the open crate uses proportionately more material and the saving is less. The nailed style open crate for heavy items requires the use of sheathing to provide fastening areas for assembly nailing to the base. This style is similar to a lumber-sheathed crate with some of the sheathing boards eliminated. The main saving of lumber in an open crate compared with a fully sheathed crate results from (a) the reduction of sheathing in top, sides, and ends; (b) the elimination of joists except the lifting joist; and (c) the elimination of most of the covering material except diagonals for the base and crosspieces.

The saving of material possible by using open crates was further illustrated at the Forest Products Laboratory by the construction and testing

of 11 large open, bolted crates carrying net loads of from 2,600 to 24,700 pounds. The average saving of lumber compared with fully sheathed crates was 12 percent in the bases, 47 percent in the sides, 49 percent in the ends, and 58 percent in the tops, or 40 percent for the entire crate. The greatest saving was in the smaller, light crates. In the nailed, open style for heavy loads, the saving averaged about 30 percent compared with a fully sheathed crate designed for the same load.

A plywood-sheathed crate often costs less than a lumber-sheathed crate. The difference in cost depends largely on the comparative prices of plywood and lumber sheathing. Since a plywood-sheathed crate does not require diagonals, the material and installation costs of diagonals may be weighed against the additional cost of the plywood. The lower tare weight and cubic displacement with plywood also should be considered.

To further reduce cost, the cubic displacement and weight of the crate and contents must be considered. Even in domestic shipment any reductions in these are important to the crate designer. The cost of shipping crates by truck or rail is generally based on weight, although large, bulky items have higher rates than smaller but heavier ones.

Air shipment of critical items is becoming more practical, and large, odd-shaped items require some type of container for blocking and mechanical protection. Here careful analysis and design are necessary to provide sufficient strength without excessive crate weight.

Export vessel shipping rates are usually based upon a ton (generally 2,240 pounds but sometimes 2,000 pounds) or on 40 cubic feet, whichever produces the greater tariff. As an average, this means that unless the crate and contents weigh more than 56 pounds per cubic foot (2,240 divided by 40) the volume rate applies. Inasmuch as most material shipped has a density much under this figure, decreasing the cubic displacement of a crate becomes very important. Crates with unnecessarily large clearances have greater volumes, which mean higher costs. A crate that weighs only 28 pounds per cubic foot will cost twice as much in freight per pound as the same size crate that weighs 56 pounds per cubic foot. The cubic displacement of a crate 100 inches long, 40 inches wide, and 50 inches high is about 116 cubic feet. By decreasing the measurements only an inch in each dimension, the displacement would be reduced to about 109 cubic feet, or a saving of 6 percent.

# MATERIALS FOR CRATES

The most important materials used in constructing crates are wood in its various forms and the fasteners used for fabrication and assembly. Sound crate design criteria and proper use of materials will result in a crate that combines maximum strength with minimum materials.

## WOOD AND WOOD-BASE MATERIALS

### Species

The species of wood most commonly used in crate construction are divided into four groups, largely on the basis of density. In general, it is good practice to use species in the same group for similar parts.

GROUP I.—softer woods of both the coniferous (softwood) and the broad-leaved (hardwood) species. These woods do not split readily when nailed and have moderate nail-holding capacity, moderate strength as a beam, and moderate capacity to resist shock. They are soft, light in weight, easy to work, hold their shape well after manufacture, and usually are easy to dry.

aspen (popple)	magnolia
basswood	pine (except southern yellow)
buckeye	redwood
cedars	spruces
chestnut	willow
cottonwood	yellow-poplar
cypress	
firs (true)	

GROUP II.—heavier coniferous woods. These woods usually have a pronounced contrast in the hardness of the springwood and the summerwood. They have greater nail-holding capacity than the group I woods, but are more inclined to split. The hard summerwood bands often deflect nails and cause them to run out at the side of the piece.

Douglas-fir	tamarack
hemlock	western larch
southern yellow pine	

GROUP III.—hardwoods of medium density. These woods have about the same nail-holding capacity and strength as a beam as the group II woods, but are less inclined to split and shatter.

ash (except white)	sweetgum
soft elm	sycamore
soft maple	tupelo

GROUP IV.—heavy hardwood species, the heaviest and hardest domestic woods. They have the greatest capacity both to resist shock and hold nails. They are often desirable for load-bearing members, skids, or joists. They are difficult to nail and tend to split when nailed, but are especially useful where high nail-holding capacity is required.

beech	hard maple	pecan
birch	hickory	rook elm
hackberry	Oaks	white ash

*Strength and variability.*—In any species, a wide

range in strength and other properties exists in lumber as it is sawed. However, average values have been established for most native species of wood.<sup>1</sup> Since these values were obtained from small, clear specimens, a number of factors must be applied to arrive at stress values suitable for the design of crates. Table 1 shows the variations in these values among species that might be used for crates. It lists not only the densities and the shrinkages from green to oven-dry condition, but also such properties as static and impact bending strength, maximum crushing strength, and hardness. Designers using these values must recognize that they are averages for each species. Wide variations are possible in individual pieces of lumber.

*Weight.*—The unit weight or density of wood is an important consideration in selecting lumber for a particular use (table 1). Weight per cubic foot not only directly influences the cost of handling and transportation, but it also is a relatively good measure of strength and resistance to nail withdrawal. And it roughly indicates the amount of shrinking and warping likely to occur with changes in moisture content. Dense woods are outstanding where high resistance to nail withdrawal is important, but they must be more carefully nailed to prevent splitting and generally they shrink more than softer, lighter woods. As a rule, the lighter woods give less trouble in seasoning, manufacture, and storage of lumber, shock, or completed containers.

The weight of dry lumber per thousand board feet varies from about 1,800 pounds for very light species to over 4,000 pounds for very heavy species. A definite way of expressing the weight of wood at a given moisture content is in pounds per cubic foot or per square foot of a specified thickness.

In the same species of wood the weight of lumber varies considerably because of differences in density. Variations exist even within wood from the same tree. For example, the swelled butts of trees of species such as sweetgum, tupelo, and ash grown in swampy soil usually contain very light wood with low strength properties; higher in the trunks of the same trees the wood is heavier and stronger.

The water in green wood often weighs more than the oven-dry weight of the wood, but in thoroughly air-dried lumber the weight of water is usually about 12 to 15 percent of the oven-dry weight of the wood, and in kiln-dried lumber it is often as low as 5 percent.

The weight of some pieces of certain species, such as southern yellow pine, western larch, and Douglas-fir, is often materially increased by resin or gum.

<sup>1</sup> U.S. Forest Products Laboratory, Wood handbook. U.S. Dept. Agr., Agr. Handbk. 72, 528 pp., illus. 1955.

TABLE 1.—Properties of wood species native to the United States that might be used for crate construction

Common and botanical name of species	Specific gravity, based on volume when green	Weight per cubic foot		Shrinkage from green to oven-dry condition based on dimensions when green		Static bending <sup>1</sup>			Impact bending (height of drop) <sup>1</sup>	Maximum crushing strength (parallel to grain) <sup>1</sup>	Hardness (side grain) <sup>1</sup>
		Green	At 15 percent moisture content	Radial	Tangential	Modulus of rupture	Modulus of elasticity	Work to maximum load			
(1)	(2)	(3)	(4)	(5)	(6)	(7)	(8)	(9)	(10)	(11)	(12)
<b>Hardwoods:</b>	0.37	Lb. 46	Lb. 28.8	Percent 4.4	Percent 7.3	P.s.i. 6,500	1,000 p.s.i. 1,170	In.-lb. per cu. in. 8.0	In. 22	P.s.i. 2,960	Lb. 440
Alder, red ( <i>Alnus rubra</i> )											
Ash:											
Black ( <i>Fraxinus nigra</i> )	.45	52	35.3	5.0	7.8	6,000	1,040	12.1	33	2,300	520
Green ( <i>F. pennsylvanica</i> )	.53	49	40.7	4.6	7.1	9,500	1,400	11.8	35	4,200	870
Oregon ( <i>F. latifolia</i> )	.50	46	38.4	4.1	8.1	7,600	1,130	12.2	39	3,510	790
White ( <i>F. americana</i> )	.54	48	42.7	4.8	7.7	9,500	1,440	15.7	36	3,990	940
Aspen:											
Bigtooth ( <i>Populus grandidentata</i> )	.35	43	27.3	3.3	7.9	5,400	1,120	5.6	18	2,500	370
Quaking ( <i>P. tremuloides</i> )	.35	43	27.0	3.5	6.7	5,100	860	6.4	22	2,140	300
Basswood, American ( <i>Tilia americana</i> )	.32	42	26.0	6.6	9.3	5,000	1,040	5.3	16	2,220	250
Beech, American ( <i>Fagus grandifolia</i> )	.56	54	44.3	5.1	11.0	8,600	1,380	11.9	43	3,550	850
Birch:											
Paper ( <i>Betula papyrifera</i> )	.48	50	38.9	6.3	8.6	6,400	1,170	16.2	49	2,360	560
Sweet ( <i>B. lenta</i> )	.60	57	47.2	6.5	8.5	9,400	1,650	15.7	48	3,740	970
Yellow ( <i>B. alleghaniensis</i> )	.55	57	43.4	7.2	9.2	8,300	1,500	16.1	48	3,380	780
Chestnut, American ( <i>Castanea dentata</i> )	.40	55	30.5	3.4	6.7	5,600	930	7.0	24	2,470	420
Cottonwood:											
Black ( <i>Populus trichocarpa</i> )	.32	46	24.5	3.6	8.6	4,800	1,070	5.0	20	2,160	250
Eastern ( <i>P. deltoides</i> )	.37	49	28.9	3.9	9.2	5,300	1,010	7.3	21	2,280	340
Cucumber tree ( <i>Magnolia acuminata</i> )	.44	49	34.3	5.2	8.8	7,400	1,560	10.0	30	3,140	520
Elm:											
American ( <i>Ulmus americana</i> )	.46	54	36.3	4.2	9.5	7,200	1,110	11.8	38	2,910	620
Rock ( <i>U. thomasi</i> )	.57	53	44.2	4.8	8.1	9,500	1,190	19.8	54	3,780	940
Slippery ( <i>U. rubra</i> )	.48	56	37.8	4.9	8.9	8,000	1,230	15.4	47	3,320	660
Hackberry ( <i>Celtis occidentalis</i> )	.49	50	37.4	4.8	8.9	6,500	950	14.5	48	2,650	700
Hickory:											
Bitternut ( <i>Carya cordiformis</i> )	.60	63	46.0			10,300	1,400	20.0	66	4,570	
Mockernut ( <i>C. tomentosa</i> )	.64	64	51.4	7.8	11.0	11,100	1,570	26.1	88	4,480	
Pecan ( <i>C. ilicoides</i> )	.60	61	46.5	4.9	8.9	9,800	1,370	14.6	53	3,990	1,310
Pignut ( <i>C. glabra</i> )	.66	64	53.4	7.2	11.5	11,700	1,650	31.7	89	4,810	
Shagbark ( <i>C. ovata</i> )	.64	64	51.2	7.0	10.5	11,000	1,570	23.7	74	4,580	
Shellbark ( <i>C. laciniata</i> )	.62	62	49.0	7.6	12.6	10,500	1,340	29.9	104	3,920	
Water ( <i>C. aquatica</i> )	.61	68	44.6			10,700	1,560	18.8	56	4,660	
Magnolia, southern ( <i>Magnolia grandiflora</i> )	.46	59	35.5	5.4	6.6	6,800	1,110	15.4	54	2,700	740
Maple:											
Bigleaf ( <i>Acer macrophyllum</i> )	.44	47	34.2	3.7	7.1	7,400	1,100	8.7	23	3,240	620
Black ( <i>A. nigrum</i> )	.52	54	40.9	4.8	9.3	7,900	1,330	12.8	48	3,270	840
Red ( <i>A. rubrum</i> )	.49	50	37.0	4.0	8.2	7,700	1,390	11.4	32	3,280	700

Silver ( <i>A. saccharinum</i> )	.44	33.9	3.0	7.2	5,800	940	11.0	29	2,490	590
Sugar ( <i>A. saccharum</i> )	.56	44.5	4.9	9.5	9,400	1,550	13.3	40	4,020	970
Oak:										
Black ( <i>Quercus velutina</i> )	.56	62	4.5	9.7	8,200	1,180	10.7	40	3,470	1,060
Bur ( <i>Q. macrocarpa</i> )	.58	62	4.4	8.8	7,200	1,880	12.7	44	3,290	1,110
Chestnut ( <i>Q. prinus</i> )	.57	61	5.5	9.7	8,000	1,370	9.4	35	3,520	890
Laurel ( <i>Q. laurifolia</i> )	.56	65	4.0	9.9	7,900	1,390	11.2	39	3,170	1,000
Northern red ( <i>Q. rubra</i> )	.56	63	4.0	8.2	8,300	1,350	13.2	44	3,440	1,000
Pin ( <i>Q. palustris</i> )	.58	63	4.3	9.5	8,300	1,320	14.0	48	3,680	1,070
Post ( <i>Q. stellata</i> )	.60	63	47.9	9.8	8,100	1,090	11.0	44	3,480	1,130
Scarlet ( <i>Q. coccinea</i> )	.60	62	47.0	9.7	10,400	1,480	15.0	54	4,090	1,200
Southern red ( <i>Q. falcata</i> )	.52	62	41.1	8.7	6,900	1,140	8.0	29	3,030	860
Swamp chestnut ( <i>Q. michauxii</i> )	.65	48.5	5.9	9.2	8,500	1,350	12.8	45	3,540	1,110
Swamp white ( <i>Q. bicolor</i> )	.64	69	51.3	10.6	9,900	1,590	14.5	50	4,360	1,160
Water ( <i>Q. nigra</i> )	.56	63	44.6	9.3	8,900	1,550	11.1	39	3,740	1,010
White ( <i>Q. alba</i> )	.62	46.8	5.3	9.0	8,300	1,250	11.6	42	3,560	1,060
Willow ( <i>Q. phellos</i> )	.56	67	44.6	9.6	7,400	1,290	8.8	35	3,000	980
Sweetgum ( <i>Liquidambar styraciflua</i> )	.46	36.4	5.4	10.2	7,100	1,200	10.1	36	3,040	600
Sycamore, American ( <i>Platanus occiden-</i> <i>talis</i> )	.46	35.7	5.1	7.6	6,500	1,060	7.5	26	2,920	610
Tupelo:										
Black ( <i>Nyssa sylvatica</i> )	.46	36.4	4.4	7.7	7,000	1,030	8.0	30	3,040	640
Water ( <i>N. aquatica</i> )	.46	35.1	4.2	7.6	7,300	1,050	8.3	30	3,370	710
Yellow-poplar ( <i>Liriodendron tulipifera</i> )	.40	30.3	4.2	7.6	6,000	1,220	7.5	26	2,660	440
Softwoods:										
Baldcypress ( <i>Taxodium distichum</i> )	.42	32.6	3.8	6.2	6,600	1,180	6.6	25	3,580	390
Cedar:										
Alaska- ( <i>Chamaecyparis nootkatensis</i> )	.42	31.6	2.8	6.0	6,400	1,140	9.2	27	3,050	440
Atlantic white- ( <i>C. thyoides</i> )	.31	23.8	2.8	5.2	4,700	750	5.9	18	2,390	290
Eastern redcedar ( <i>J. virginiana</i> )	.44	37	3.1	4.7	7,000	650	15.0	35	3,570	650
Incense- ( <i>Libocedrus decurrens</i> )	.35	25.5	3.3	5.2	6,200	840	6.4	17	3,150	390
Northern white- ( <i>Thuja occidentalis</i> )	.29	21.8	2.1	4.7	4,200	640	5.7	15	1,990	230
Port-Orford- ( <i>Chamaecyparis lawsoniana</i> )	.40	36	4.6	6.9	6,200	1,420	7.4	21	3,130	400
Western redcedar ( <i>Thuja plicata</i> )	.31	27	2.4	5.0	5,100	920	5.0	17	2,750	270
Douglas-fir:										
Coast type ( <i>Pseudotsuga menziesii</i> )	.45	34.3	4.8	7.6	7,600	1,570	7.6	26	3,860	500
Intermediate type ( <i>P. menziesii</i> )	.41	31.5	4.2	7.4	6,800	1,350	6.6	21	3,300	450
Rocky Mountain type ( <i>P. menziesii</i> var. <i>glauca</i> )	.40	30.5	3.6	6.2	6,400	1,180	6.8	20	3,000	400
Fir:										
Balsam ( <i>Abies balsamea</i> )	.34	26.9	2.8	6.6	4,900	960	4.7	16	2,400	290
California red ( <i>A. magnifica</i> )	.37	50	4.5	7.9	6,000	1,210	6.4	21	2,850	360
Grand ( <i>A. grandis</i> )	.37	45	3.2	7.2	6,100	1,300	5.6	22	3,020	360
Noble ( <i>A. procera</i> )	.35	30	4.5	8.3	5,800	1,270	6.0	19	2,740	290
Pacific silver ( <i>A. amabilis</i> )	.36	38	4.5	9.4	5,900	1,330	6.6	21	2,840	350
White ( <i>A. concolor</i> )	.35	47	3.2	7.0	5,700	1,030	5.1	22	2,710	330
Hemlock:										
Eastern ( <i>Tsuga canadensis</i> )	.38	29.0	3.0	6.8	6,400	1,070	6.7	21	3,080	400
Western ( <i>T. heterophylla</i> )	.38	41	4.3	7.9	6,100	1,220	6.8	22	2,990	430
Larch, western ( <i>Larix occidentalis</i> )	.51	9.4	4.5	9.1	8,200	1,530	10.3	29	3,990	510

See footnote at end of table.

TABLE 1. — Properties of wood species native to the United States that might be used for crate construction — Continued

Common and botanical name of species	Specific gravity, oven-dry, based on volume when green	Weight per cubic foot		Shrinkage from green to oven-dry condition based on dimensions when green		Static bending <sup>1</sup>			Impact bending (height of drop) <sup>1</sup>	Maximum crushing strength (parallel to grain) <sup>1</sup>	Hardness (side grain) <sup>1</sup>
		Green	At 15 percent moisture content	Radial	Tangential	Modulus of rupture	Modulus of elasticity	Work to maximum load			
(1)	(2)	(3)	(4)	(5)	(6)	(7)	(8)	(9)	(10)	(11)	(12)
<b>Softwoods—Continued</b>											
Pine:											
Eastern white ( <i>Pinus strobus</i> )	0.34	Lb. 37	Lb. 25.4	Percent 2.1	Percent 6.1	P.s.i. 4,900	1,000 p.s.i. 990	In.-lb. per cu. in. 5.2	In. 17	P.s.i. 2,440	Lb. 290
Jack ( <i>P. banksiana</i> )	.40	40	30.3	3.7	6.6	6,000	1,070	7.2	26	2,950	400
Lodgepole ( <i>P. contorta</i> )	.38	39	29.2	4.5	6.7	5,500	1,080	5.6	20	2,610	330
Ponderosa ( <i>P. ponderosa</i> )	.38	47	28.9	3.8	6.2	5,100	970	5.2	21	2,400	320
Red ( <i>P. resinosa</i> )	.41	49	31.4	3.8	7.2	5,800	1,280	6.1	26	2,730	340
Southern yellow:											
Loblolly ( <i>P. taeda</i> )	.47	53	36.3	4.8	7.4	7,300	1,410	8.2	30	3,490	450
Longleaf ( <i>P. palustris</i> )	.54	55	41.6	5.1	7.5	8,700	1,600	8.9	35	4,300	590
Shortleaf ( <i>P. echinata</i> )	.46	52	35.7	4.4	7.7	7,300	1,390	8.2	30	3,430	440
Slash ( <i>P. Elliottii</i> )	.54	58	41.7	5.4	7.6	8,600	1,590	9.6	35	4,210	580
Sugar ( <i>P. Lambertiana</i> )	.35	51	26.0	2.9	5.6	5,100	940	5.4	17	2,530	310
Western white ( <i>P. monticola</i> )	.36	35	28.0	4.1	7.4	5,200	1,170	5.0	19	2,650	310
Redwood, old-growth ( <i>Sequoia sempervirens</i> )	.38	50	28.6	2.6	4.4	7,500	1,180	7.4	21	4,200	410
Spruce:											
Black ( <i>Picea mariana</i> )	.38	32	28.8	4.1	6.8	5,400	1,060	7.4	24	2,570	370
Engelmann ( <i>P. engelmannii</i> )	.32	35	24.1	3.6	7.1	4,500	960	5.1	16	2,190	260
Red ( <i>P. rubens</i> )	.38	34	28.4	3.8	7.8	5,800	1,190	6.9	18	2,650	350
Sitka ( <i>P. sitchensis</i> )	.37	33	28.1	4.2	7.5	5,700	1,230	6.3	24	2,670	350
White ( <i>P. glauca</i> )	.37	35	29.4	3.8	7.5	5,600	1,070	6.0	22	2,570	320
Tamarack ( <i>Larix laricina</i> )	.49	47	37.6	3.7	7.4	7,200	1,240	7.2	28	3,480	380

<sup>1</sup> Results from small, clear specimens in the green condition.

## Other Factors Affecting Wood Strength

Some important factors besides species that affect the strength of lumber used for crates are (1) moisture content, (2) duration of load, and (3) size, number, and location of strength-reducing characteristics, such as knots and cross grain.

**Moisture content.**—The wood of live trees contains tremendous quantities of water, which is slowly lost after trees are cut, and particularly after they are sawed into lumber. For most uses of wood, including crates, almost all moisture must be removed.

Moisture is held in wood within the cell cavities and the cell walls. When all the moisture has evaporated from the cell cavities, but the cell walls remain saturated, wood is said to have reached the fiber-saturation point. For practical purposes, the fiber-saturation point is considered to be 30 percent moisture content for most species. Moisture content is the weight of the water contained in the wood expressed as a percentage of the weight of the oven-dry wood.

As wood loses moisture below the fiber-saturation point, it begins to shrink. Wood dried to 15 percent moisture content has shrunk about half as much as possible. If dried in an oven, a sample would continue to shrink as moisture is lost, until reaching 0 percent moisture content.

Actually, wood will stop drying when it reaches equilibrium with the temperature and humidity surrounding it. This point, known as the equilibrium moisture content, varies widely with climatic conditions and use of the wood.

As wood dries, the fibers begin to stiffen and strengthen when the fiber-saturation point has been reached. But toughness and shock resistance sometimes actually decrease. This is because dried wood will not bend as far as green wood before failure (although it will sustain a greater load), and toughness is dependent upon both strength and pliability.

The gain in strength of large members by drying is somewhat offset by the accompanying splitting and checking. A change from green condition to 12 percent moisture content, however, can result in a 30 to 100 percent increase in strength in the various species. The following tabulation represents the average change in wood and strength properties with a 1 percent change in moisture content (between approximately 30 and 12 percent).

	<i>Changes (percent)</i>
Static bending:	
Modulus of rupture.....	4.0
Modulus of elasticity.....	2.0
Work to maximum load.....	.5
Impact bending, height of drop causing complete failure.....	.5
Maximum crushing strength (parallel to grain).....	6.0
Side hardness.....	2.5

**Duration of load.**—Wood is able to support large overloads for short periods and small overloads for longer periods. This property is important if short-time load is contemplated, such as a one-trip crate shipped directly to its destination with no storage period. However, it is better to disregard it in designing crates for longtime storage. A wood member can support continuously for 1 year only about two-thirds of the load required to cause failure in a standard strength test of only a few minutes' duration.

Wood under a continuous load, such as might be imposed on a crate in storage with other boxes or crates placed on top, tends to deform. The set or sag of the joists, an illustration of this, is greatest when moisture content of the material is high.

**Knots.**—Knots are cross sections of branches that are visible on the surface of a piece of wood. They interrupt the direction of grain and cause localized cross grain with steep slopes. While some types of knots affect the resistance to stresses, no distinction is made between live knots, dead knots, and knotholes in determining the strength value of any piece of lumber. In building crates both size and location of knots must be considered.

The effect a knot has on the strength of a piece of lumber depends on the proportion of the cross section occupied by the knot. Limits of knot sizes should therefore be based on the width of the face in which the knot appears.

Knots reduce tensile strength more than compressive or shear strength, and their location along the length of the piece is considered only in bending. Knots located near midspan and at the top or bottom edges have the most effect on the strength of a piece subjected to bending. A sound knot at the top part of a joist near midspan is in compression and usually has only a moderate influence on the strength of the piece in bending.

**Slope of grain.**—Slope of grain refers to the direction of the wood fibers in relation to the longitudinal axis of a piece of lumber. When these fibers are not parallel with the longitudinal axis, the wood is said to be cross grained. The slope, measured by the angle between the general direction of the grain and the axis, is expressed as a ratio, as 1 in 12 (1-inch slope in a 12-inch distance). Slight local deviations of grain direction are usually disregarded. When cross grain is quite steep, there is a marked reduction in strength. A slope of grain of 1 in 8 in a member subjected to bending under impact loads will result in its having 53 percent of the strength of a piece without grain deviation. This requires a reduction in the assigned working stresses to offset the loss in strength. Besides having less strength, pieces with cross grain tend to twist with changes in moisture content.

Slope of grain, therefore, must be limited for such crate parts as joists, load-bearing floorboards, struts, upper and lower frame members, diagonals,

and skids of sheathed crates. Fewer restrictions on slope of grain exist for items such as lumber sheathing, rubbing strips, and nonstructural block-in and bracing than for structural members.

*Decay.*—Decay, a disintegration of wood, results from the action of wood-destroying fungi. It seriously affects the strength properties of wood and its resistance to nail withdrawal.

*Blue stain.*—Also called sap stain, this bluish discoloration of the sapwood is caused by a fungus. It does not reduce the strength of the wood. However, the conditions that favor development of this fungus are also ideal for the growth of wood-destroying fungi, so bad staining may indicate existence of decay. When blue stain is present in sheathing boards or frame members, it may obscure markings on the crate.

*Insect attack.*—Certain woods are subject to insect attack as green lumber, some as dry lumber, and some as partly seasoned lumber. The sapwood of some seasoned hardwoods is subject to attack by the powder-post beetle. Small wormholes have only a very slight effect on the strength and, if the wood is otherwise sound, it is quite satisfactory for crates.

*Wane.*—Wane is either bark or lack of wood on the edge or corner of a piece of lumber. Acceptability of pieces with wane is usually restricted for structural members because of the reduced cross sectional area. Wane is less serious in lumber sheathing than in such crate parts as frame members and skids.

*Shakes.*—A shake is a separation along the grain, largely between the growth rings, which occurs while the wood is seasoning. Shakes in members subjected to bending reduce the resistance to shear and therefore should be closely limited in structural members. Restrictions of shakes in boards are usually based on the length of the split or opening.

*Checks and splits.*—Checks and splits, lengthwise openings from separations during seasoning, may reduce wood's resistance to shear. They are judged on the basis of the area of actual opening. An end split is considered the same as an end check that extends through the full thickness of the piece.

*Warping.*—Warping is any variation of a piece of material from a true or plane surface and includes bow, crook, cup, and twist. Generally warping does not affect the strength of crate parts, but it makes fabrication more difficult and reduces the utility of the container.

## Working Stresses

In calculating the proper size of crate members, working stresses must be assigned to the wood to be used. The magnitudes of working stresses vary generally by species, the denser woods having the higher values. However, a

number of other factors determine the final working stress. These include moisture content, variability within the species, impact loading consideration, and strength-reducing characteristics.

The following is a system of computing basic stresses for crate lumber, and then applying reductions to obtain working stresses.

1. The strength of green lumber of a species, based on average laboratory values of small clear specimens, is selected as a starting point. This assumes that the lumber will be stressed at some time when it is wet.

2. The green value is then reduced by a variability factor, because the strength of any species of wood is variable. The factor used for structural lumber is usually three-fourths. It means that only about 5 out of every 100 pieces will be weaker than three-fourths of the green value.

3. A factor for impact loading is then applied. In handling and shipping, stresses are applied by lifting, handling, and dropping accidentally. These impact stresses are much greater than the static or slowly applied loads, such as top loads in storage. The usual factor for impact loads is about one-third.

Basic stresses, obtained by applying these two factors, correspond to clear lumber grades and provide a measure of the inherent strength of clear wood.

4. Finally, allowances are made for the maximum effect of such characteristics as knots and cross grain. Table 2 shows reduction factors. The larger factor, whether for knots or cross grain, is the one used. When the basic stresses are reduced by these factors, they become the working stresses.

An example of the way a working stress for a crate is ordinarily computed from laboratory test values for white fir is given below. White fir was picked because it is one of the weakest woods used in container construction.

$$\begin{aligned} \text{Green modulus of rupture} &= 5,700 \text{ pounds per} \\ &\quad \text{square inch} \\ &\quad \text{(table 1)} \\ \text{Variability factor} &= \frac{3}{4} \\ \text{Impact factor} &= \frac{1}{3} \\ \text{Basic stress} &= 5,700 \times \frac{3}{4} \times \frac{1}{3} = 1,425 \text{ pounds per} \\ &\quad \text{square inch} \end{aligned}$$

For maximum allowable knot sizes equal to one-fourth of the width and for cross grain up to 1 in 15, the reduction factor is 25 percent.

Working stress =  $1,425 - (0.25 \times 1,425) = 1,069$  pounds per square inch

Working stresses for other species may be determined in a similar manner. The crate designer dealing with several species in the same wood group should select an average working stress suitable for all.

For structural uses,<sup>2</sup> basic stresses are given in the Wood Handbook<sup>2</sup> for various species. Also included is a discussion of strength ratios which, when applied to basic stresses, yield working stresses. Thus allowable working stresses can be calculated for various grades of lumber, such as "structural" and "nonstructural."

TABLE 2.—*Reduction factors used to compute working stresses from basic stresses*

Strength-reducing characteristic	Strength in—			
	Tension	Com- pression	Bending	
			Flat	On edge
	Percent	Percent	Percent	Percent
<b>Knots:</b>				
One-fourth of the width.....	25	13	25	<sup>1</sup> 43
One-third of the width.....	33	17	33	<sup>1</sup> 53
One-half of the width.....	50	25	50	<sup>1</sup> 74
<b>Cross grain:</b>				
1 in 20.....	0	0	0	0
1 in 15.....	24	0	24	24
1 in 10.....	39	26	39	39
1 in 8.....	47	34	47	47
1 in 6.....	60	44	60	60

<sup>1</sup> Knots assumed to be in the worst position, at the center of the length and at the edge of the wide face.

The lumber grades are based on the size, location, and number of strength-reducing characteristics in species used for miscellaneous construction. The lumber used for frame members and sheathing of crates is usually of a lower grade than that listed in the tables and consequently would have somewhat lower values for the allowable working stresses.

To calculate basic stresses for structural lumber, impact loading is generally ignored, but longtime loading and a safety factor are considered. A piece of wood will carry less load for a long time than it will for the short period of the laboratory test. The reduction factor for longtime loading is between nine-sixteenths and three-fourths. After it is applied, the piece is considered capable of supporting its load for a long time. A safety factor of three-fifths or two-thirds is then applied to take care of other conditions of loading that are indeterminate but tend to reduce the strength.

The combined longtime loading and safety factors are about equal to the impact loading factor used for crate lumber. Therefore, for structural lumber and crate lumber, basic stresses are approximately equal.

<sup>2</sup> See footnote 1, p. 5.

## Lumber Sizes

Most of the lumber used for crates is nominally 1 or 2 inches thick. However, such members as skids, headers, load-bearing floorboards, and fastening members often are thicker. All nominal dimensions are normal rough-sawn widths and thicknesses, and any dressing or surfacing will reduce them. Face dressing may be S1S or S2S (surfaced 1 or 2 sides). Edge dressing may be S1E or S2E (surfaced 1 or 2 edges). When both faces and both edges of a piece of lumber are surfaced, the cross section should have minimum thickness and width. These minimum allowable dimensions, for any combination of surfacing and edging, should follow those listed in table 3. Unless designated otherwise, the lumber dimensions in this handbook are nominal.

When sizes other than those listed in table 3 are used, undersize in thickness or width due to mismanufacture may be permitted in not more than 10 percent of the pieces. However, no part should be thinner than seven-eighths of the required thickness, or narrower than one-fourth inch less than the required width.

Rough lumber is used for the base of most crates and for the framing of sheathed crates. At least one surface of all other members should be dressed and placed on the outside of the crate to receive marking.

TABLE 3.—*Nominal and minimum allowable dimensions of softwood lumber<sup>1</sup> for crates*

Thickness (smaller dimension)		Width (larger dimension)	
Nominal	Minimum	Nominal	Minimum
<i>Inches</i>	<i>Inches</i>	<i>Inches</i>	<i>Inches</i>
1.....	<sup>2</sup> 3/4	2	1 1/8
2.....	1 1/8	3	2 1/8
3.....	2 1/8	4	3 1/8
4.....	3 1/8	5	4 1/8
5 and thicker..	1/2 less	6 and wider	1/2 less

<sup>1</sup> Hardwood lumber is bought and sold on a basis of actual rather than nominal dimensions. The minimum allowable dimensions listed here are applicable to hardwoods.

<sup>2</sup> In American Lumber Standards, the actual thickness for a nominal 1-inch board is 25/32 inch. The 3/4-inch thickness listed is not intended to represent lumber standard, but rather is one of the thicknesses of softwood lumber used in crate design.

## Plywood

Plywood is a sheet material made of three or more layers of thin wood veneer glued together. The grain of each ply is placed at an angle, usually 90°, with the grain of the adjoining ply. The

outside plies are called faces (or face and back) and the center ply or plies are called the core. Plywood of three, five, seven, or more plies, depending on the type and thickness, is used as sheathing for crates of all sizes.

The strength properties of plywood depend upon the species of wood and the number and thicknesses of the plies. As the number of plies is increased, the strengths parallel and perpendicular to the face plies become more nearly equal, assuming the plies are all about the same thickness. The resistance to splitting also increases rapidly with the number of plies (table 4). When plywood is composed of a very large number of plies

of the same thickness or if the middle layer of three-ply stock is about seven-tenths the total thickness, the bending strength is about the same either parallel or perpendicular to the grain of the face plies.

*Grades and types.*—The plywood used for sheathing material in crates complies with sheathing material specifications. The two classes of plywood are hardwood plywood and softwood plywood. While much softwood plywood is made of Douglas-fir, hardwood plywood is made of many species. Grade of plywood is determined by the quality of the outside plies. Type of plywood is determined by the moisture resistance of the glue joints.

TABLE 4.—Effect of number of plies on strength properties of plywood of the same total thickness

Number of plies	Bending strength			Strength in tension			Resistance to splitting
	Parallel <sup>1</sup>	Perpendicular <sup>2</sup>	Ratio of perpendicular to parallel	Parallel <sup>1</sup>	Perpendicular <sup>2</sup>	Ratio of perpendicular to parallel	
	Percent	Percent	Percent	Percent	Percent	Percent	Percent
3-----	100	100	20	100	100	58	100
5-----	74	167	45	96	113	68	185
7-----	72	193	54	90	119	78	235
9-----	51	182	72	77	109	83	340

<sup>1</sup> Stress applied parallel to grain of face plies.

<sup>2</sup> Stress applied perpendicular to grain of face plies.

Exterior and Interior are the two types of softwood plywood. Exterior is expected to be suitable for permanent exterior use. Interior is expected to retain its form and most of its strength when only occasionally subjected to wetting and drying. Several grades are established within each type by the quality of the veneer on the two faces of a panel. In Douglas-fir plywood the veneer is designated as A, B, C, or D, in descending order of quality.

Hardwood plywoods are of four types—Technical, Type I, Type II, and Type III. Principal difference between types is in the resistance of the glue bond to severe service conditions. Glue bonds in both Technical and Type I are high in durability, corresponding to Exterior-type Douglas-fir plywood. These two types differ only in the permissible thickness and arrangement of plies. Resistance of glue bonds of Type II hardwood plywood resembles that of Interior-type Douglas-fir plywood. Type III hardwood plywood has glue bonds with good dry strength but no moisture resistance. Grade of hardwood plywood is determined by the quality of the veneer on the face and back of a panel. The veneer is graded 1, 2, 3, and 4, in descending order of quality.

For use in crates, these are the general groupings:

Exterior-type softwood plywood and Technical and Type I hardwood plywood are weatherproof and are ordinarily employed for reusable crates that will meet severe exposure conditions. These types may have surfaces treated with a water repellent or untreated.

Interior-type softwood plywood and Type II hardwood plywood are moisture resistant and are ordinarily used for crates to be shipped overseas or exposed to moderate weather conditions in shipping or storage. These also are treated or untreated.

Type III hardwood plywood is used for ordinary shipping crates where little outdoor storage is contemplated. It comes in untreated or treated forms.

*Special qualities of plywood use.*—Plywood has the following advantages as a sheathing material for crates:

1. Its use eliminates the need for diagonals, which are ordinarily required for lumber-sheathed crates. Plywood sheathing resists racking and is very rigid in panel form when perimeter nailing is used.

2. Since plywood is resistant to splits it is possible to nail close to the edges of the panel.

3. The shrinkage of plywood is so minor that it need not be considered in crate design.

4. Plywood dimensions are actual, rather than

nominal, so it is easy to calculate the amount needed.

5. A plywood-sheathed crate does not require a liner for waterproofing.

6. As the number of plies increase plywood approaches balanced construction, with moderate bending strength in two directions.

7. The use of plywood reduces the cubic displacement required for lumber sheathing in most crates because the plywood is usually not as thick as lumber. Weight is also reduced because plywood is thinner and diagonals are not required.

With these advantages, there are some special factors to be considered in using plywood: (1) In the thicknesses required for crates it usually costs more than similar lumber sheathing. This must be weighed against a possible saving in labor with plywood. (2) Waste occurs more often. Vertical members can be spaced in modules to fit the width of the sheet, but there is end waste when the crate height does not correspond to the sheet length. (3) A plywood-sheathed crate usually requires struts more closely spaced than struts in a similar lumber-sheathed crate.

### Paper-Overlaid Veneer

Paper-overlaid veneer is a sheet material made of a thin veneer core with paper facing on each side. Among its uses is sheathing for lightweight crates where heavier sheathing to resist stacking loads is not needed. Various core veneers are used. One three-ply material, for example, has a hardwood veneer core faced on each side with kraft paper; core thickness may vary from one-sixteenth to one-sixth inch. Another material has a Douglas-fir veneer core and kraft paper facings; core thickness is usually one-eighth to three-sixteenths inch. Some of the materials have greater bending strength in one direction because the veneer core is much thicker than the paper facings. Other materials have more balanced strength because the paper facings are thick enough to increase the crosswise bending strength.

Paper-overlaid veneers that are used in sheathing crates are generally much thinner than plywoods and lack their resistance to nailhead pull-through. Therefore, it is necessary to use nails with larger heads and space them somewhat closer to insure good fabrication strength. Because of the deflection of paper-overlaid veneer, it is necessary to use closer spacing for struts and other framing members than is ordinarily used for plywood-sheathed crates. However, for sheathing lightweight crates using nominal 1-inch-thick framing material, paper-overlaid veneer can be specified successfully by the crate designer.

### FASTENINGS

The strength and rigidity of crates are highly dependent on the fastenings. Nails, lag screws,

bolts, screws, and metal connectors are the most important fastenings in crate construction. Recent developments by the manufacturers of staples and driving equipment indicate that staples may be satisfactory substitutes for nails. Advances in adhesive research may also make glued fabrication of crates practicable.

Crate fastenings have two general purposes: fabricating the parts to form panels, and assembling the panels. Nails are used almost invariably for fabrication, while nails and other types of fastenings may be used for assembly.

### Nails

Nails are the fasteners most commonly used in crate construction. Many standard types and sizes are used in addition to special-purpose nails. Fabrication, such as nailing the sheathing to the frame members, usually involves driving the nails through two or more pieces and clinching them.

Clinching the nails greatly increases their withdrawal resistance. In assembly, however, clinching the nails is usually impractical, so their withdrawal resistance depends on the type and size of the nail shank and the depth of penetration.

*Nail types.*—The nails most commonly used in the construction of crates are common, sinker, and cooler nails.<sup>3</sup> Shank treatment is not necessary for nails clinched in fabrication. Surface coating or roughening or shank deformation increases the withdrawal resistance of nails used in assembly. Often used are cement-coated nails of the sinker, cooler, or box type. Figure 4 shows the common, bright box, cement-coated coolers and sinkers, the clout, and deformed-shank nails.

Common and bright box nails are those most often used in fabrication nailing where clinching is required. They are the same length in each size, but the box nail is slightly smaller in diameter. Clout nails are commonly used to fasten plywood or other sheet materials to the thinner frame members of crates. These nails are comparatively short, with long duckbill points that clinch easily and larger heads than other container nails of comparable length.

*Nail sizes.*—The size of most nails is based on their length; the diameter or gage varies by the length and the nail type. Nail size is usually expressed by the penny system, abbreviated as cl. For example, a sixpenny nail is expressed as 6d and an eightpenny as 8d. The penny system originated in England and is said to have been based on the weight of a thousand nails. For example, 1,000 tenpenny nails weighed 10 pounds, and 1,000 eightpenny nails weighed 8 pounds.

<sup>3</sup> Anderson, L. O. Nailing better wood boxes and crates. U.S. Dept. Agr., Agr. Handbk. 160, 40 pp., illus. 1959.

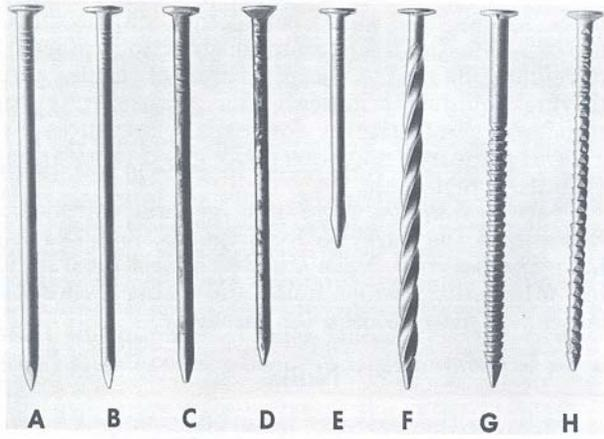

M-119861

Figure 4.—Nail types: A, Common, B, bright box; C, cooler (cement coated); D, sinker (cement coated), E, clout, F, spirally grooved; G, annular grooved, H, barbed.

Present lengths, gages, and number per pound of several standard types of nails are shown in table 5.

*Calculating nail-holding capacity.*—During handling and shipping of crates, the nails are subjected to direct withdrawal and lateral forces. Direct withdrawal resistance is the resistance of a nail to forces parallel to its axis that tend to pull it from a piece of wood. Lateral resistance is the resistance of a nail to forces applied at right angles to its length. These resistances can be calculated.

TABLE 5.—Length, gage, and number per pound for standard sizes and kinds of nails commonly used in crates

Size of nail <sup>1</sup>	LENGTH				
	Bright		Cement-coated		
	Common	Box	Sinkers	Coolers	Box
	Inches	Inches	Inches	Inches	Inches
2d.....	1	1	-----	1	-----
3d.....	1¼	1¼	1½	1½	1½
4d.....	1½	1½	1¾	1¾	1¾
5d.....	1¾	1¾	1¾	1¾	1¾
6d.....	2	2	1¾	1¾	1¾
7d.....	2¼	2¼	2½	2½	2½
8d.....	2½	2½	2½	2½	2½
9d.....	2¾	2¾	2½	-----	2½
10d.....	3	3	2½	2½	2½
12d.....	3¼	3¼	3½	-----	-----
16d.....	3½	3½	3¼	-----	-----
20d.....	4	4	3¼	-----	-----
30d.....	4½	-----	4¼	-----	-----
40d.....	5	-----	4¾	-----	-----
50d.....	5½	-----	5¼	-----	-----
60d.....	6	-----	5¾	-----	-----

GAGE NUMBER<sup>2</sup>

Size of nail <sup>1</sup>	Bright		Cement-coated		
	Common	Box	Sinkers	Coolers	Box
	Inches	Inches	Inches	Inches	Inches
2d.....	15	15½	-----	16	-----
3d.....	14	14½	15½	15½	16
4d.....	12½	14	14	14	15½
5d.....	12½	14	13½	13½	15
6d.....	11½	12½	13	13	13½
7d.....	11½	12½	12½	12½	13½
8d.....	10¾	11½	11½	11½	12½
9d.....	10¾	11½	11½	-----	12½
10d.....	9	10½	11	11	11½
12d.....	9	10½	10	-----	-----
16d.....	8	10	9	-----	-----
20d.....	6	9	7	-----	-----
30d.....	5	-----	6	-----	-----
40d.....	4	-----	5	-----	-----
50d.....	3	-----	4	-----	-----
60d.....	2	-----	3	-----	-----

APPROXIMATE NAILS PER POUND

	Number	Number	Number	Number	Number
2d.....	830	1, 010	-----	1, 094	-----
3d.....	528	635	850	848	988
4d.....	316	473	495	488	710
5d.....	271	406	364	364	522
6d.....	168	236	275	275	310
7d.....	150	210	212	212	283
8d.....	106	145	142	142	191
9d.....	96	132	130	-----	172
10d.....	69	94	104	104	118
12d.....	63	88	77	-----	-----
16d.....	49	71	61	-----	-----
20d.....	31	52	37	-----	-----
30d.....	24	-----	29	-----	-----
40d.....	18	-----	21	-----	-----
50d.....	14	-----	16	-----	-----
60d.....	11	-----	13	-----	-----

<sup>1</sup> Bolts are often preferred where nails larger than twentypenny would be required.

<sup>2</sup> Conformed to the American Steel and Wire Company steel wire gage.

The resistance of a nail to movement is affected by the density of the wood, the moisture content of the wood and any changes in it, diameter of the nail, depth of penetration into the wood, surface condition of the nail shank, type of nail-head and point, direction of driving, and clinching. Most of these factors have an influence on the direct-withdrawal resistance of the nail; several affect the lateral resistance and the splitting of the wood.

**Density.**—Specific gravity has been found to be the best single standard upon which to base the strength properties of wood. A general relationship exists between it and nail withdrawal resistance. In woods of high density, the correspondingly high proportion of wood substance offers greater resistance to distortion and, consequently, to nail withdrawal.

**Moisture content.**—When nails are driven into pieces of wood of different moisture contents and pulled immediately, some variations are evident in the withdrawal resistance values. More important than the effect of moisture content, however, is the effect of change in moisture content. A nail driven into green wood and pulled immediately has almost four times the withdrawal resistance it would have if it were pulled a year later, after the wood had dried. Whenever any moisture change occurs in wood, nails lose a large part of their original resistance to withdrawal.

**Diameter of nail.**—Nail diameter has much effect on both lateral resistance and resistance to direct withdrawal. The greater the diameter, the greater is the resistance, but also the greater is the likelihood that the wood will split. This is especially true of dense species when the moisture content is low.

**Depth of penetration.**—The depth to which a nail penetrates is directly related to its withdrawal resistance because the deeper the penetration, the greater the contact with the wood fibers. Withdrawal resistance is calculated on the basis of the depth of penetration in inches. In lateral resistance a minimum penetration is required, and no premium is allowed for greater penetration. Since the nail is often subjected to both lateral and withdrawal stress, good penetration has its advantages.

**Surface condition of the nail.**—To increase the withdrawal resistance of the nail, the shank is sometimes modified by coating, roughening, or deforming it.

Surface coatings are usually of "cement" or zinc. The cement-coated nail in particular has a greater resistance to immediate withdrawal than the common nail, but may lose much of this advantage in a few months. Furthermore, different techniques for applying the coating and variations in the ingredients cause large differences in the withdrawal resistance. In low-density woods the cement coating, if properly applied, adds materially to withdrawal resistance. In denser woods much of the coating may be removed as the nail is driven.

Nail surfaces may be roughened by either chemical etching or sandblasting. In both types the roughened portions will engage the wood fibers and provide some resistance to withdrawal.

Deformed-shank nails are designed to retain a great percentage of their withdrawal resistance even after the wood has undergone many changes

in moisture content. The two most common varieties are spirally grooved and annular grooved. In general, annular grooved nails sustain larger static-withdrawal loads than other nail forms, and spirally grooved nails sustain greater impact-withdrawal loads.

**Type of nailhead and point.**—Nailheads prevent nailed pieces from pulling loose when a force is applied. Nailheads vary in size and shape (fig. 5), but most nails used in crates have a round, flat head. The countersunk nailhead is strong enough to withstand the force required to withdraw the nail from most species of wood. Nails with thin, flat heads should not be used in dense woods, because the nailhead may be broken off or damaged when the nail is driven, or when stresses are applied. When nailheads are damaged, the strength of the joint is greatly reduced.

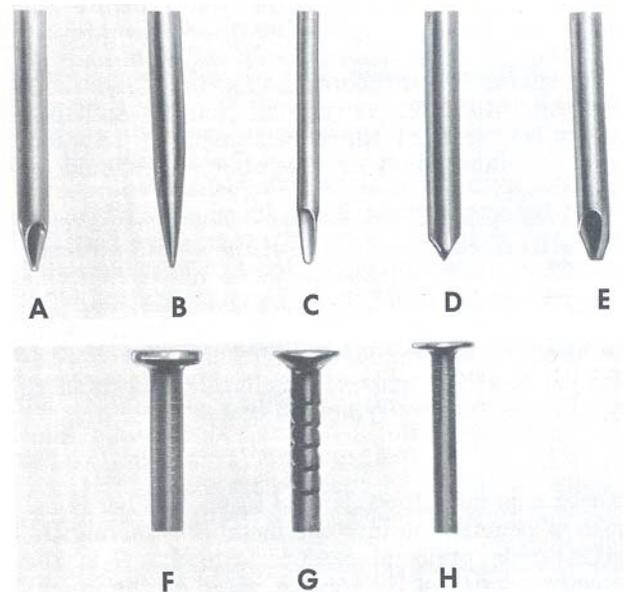

M-119662

Figure 5.—Various types of nail points and heads: A, Diamond; B, needle; C, duckbill; D, chisel; E, blunted; F, flat; G, countersunk; H, broad flat.

Shape of the nail point has some influence on withdrawal resistance. Nails with long, sharp, conical points will usually have higher withdrawal resistance than nails with the commonly used diamond points (fig. 5). However, the sharp-pointed nail's tendency to split the denser species of wood lowers its withdrawal resistance. Nails with blunt or flat, untapered points do not split wood so easily. They tear the wood fibers much more, however, and therefore have lower withdrawal resistance than common wire nails.

**Direction of driving.**—Resistance of nails to withdrawal is greatest when they are driven perpendicular to the grain of the wood. When they are driven parallel to the wood fibers, as into the

ends of a piece, their holding power may drop to as low as 50 percent of the side-grain values. Slant driving has some advantages over straight driving when nails are driven into the end grain of wood.

**Clinching.**—Clinching is one of the best methods of increasing the effectiveness of nails. It is used almost entirely in the fabrication of crate panels, except when frame members or other crate parts are greater than 2 inches thick. Clinched nails have 50 to 150 percent greater withdrawal resistance than unclinched nails when driven into dry pine or Douglas-fir and pulled immediately. Clinched nails in green wood that dries after the nails are driven have 250 to 450 percent greater holding capacity than unclinched nails of the same diameter. Nails that are clinched across the grain are about 20 percent more effective than those clinched with the grain.

**Predrilling.**—Predrilling the wood before the nails are driven may be necessary to prevent splitting in very dense woods or with nails of large diameter. Prebored holes should be about the same diameter as the nail shank. Splitting, of course, reduces the effectiveness of any nail used for fabrication or assembly and should be prevented.

**Direct-withdrawal resistance.**—The relative resistance to direct withdrawal of nails with circular, uncoated, plain shanks depends on the specific gravity of the wood, the nail diameter, and the depth of penetration. The following formula may be used to determine the allowable direct-withdrawal load for nails of any size under loading conditions that are typical in crates:

$$P=1,380 G^{5/2} D$$

where *P* is the allowable load in pounds per lineal inch of penetration into the member receiving the point (side grain of seasoned wood); *G* is the specific gravity of the species, based on the weight and volume when oven-dry; and *D* is the diameter of the nail in inches.

Table 6 lists the specific gravity, *G*, and the  $G^{5/2}$  value for a number of woods that may be used in the construction of crates.

For convenience in determining withdrawal values of nails by the formula, table 7 lists nail diameters and other data for the bright common nail. When nails of other types (such as sinkers) are used, the gage, length, and other values will change from those listed in the table.

The type of nail most often used in assembly of crates is the cement-coated sinker nail. It is available in a wide variety of sizes and has a strong countersunk head. Table 8 lists the average allowable load in direct withdrawal for plain sinker nails (or nails of equal diameter and penetration) in crate construction. These values are considered satisfactory for loading and storage conditions to which crates are normally subjected.

Under extreme conditions of shipping, storage, or handling, allowable loads may be reduced. The values given in table 8 do not include allowances for any shank coating, roughening, or deformation. The additional resistance that a modified shank provides may be considered a safety factor.

TABLE 6.—Values for specific gravity (*G*) of oven-dry wood used in calculating direct-withdrawal loads for nails and lag screws

G	$G^{5/2}$	$G^{3/2}$	G	$G^{5/2}$	$G^{3/2}$
0.29	0.05	0.16	0.50	0.18	0.35
.31	.05	.17	.51	.19	.36
.32	.06	.18	.52	.19	.37
.34	.07	.20	.53	.20	.39
.35	.07	.21	.54	.21	.40
.36	.08	.22	.55	.22	.41
.37	.08	.22	.56	.23	.42
.38	.09	.23	.57	.25	.43
.40	.10	.25	.58	.26	.44
.41	.11	.26	.60	.28	.46
.42	.11	.27	.61	.29	.48
.44	.13	.29	.62	.30	.49
.45	.14	.30	.64	.33	.51
.46	.14	.31	.66	.35	.54
.47	.15	.32	.67	.37	.55
.48	.16	.33	.71	.42	.60
.49	.17	.34	.74	.47	.64

TABLE 7.—Sizes of bright common wire nails

Size	Gage	Length	Diameter	
			D	$D^{3/2}$
<i>Penny</i>		<i>Inches</i>	<i>Inch</i>	<i>Inch</i>
4-----	12½	1½	0.098	0.0307
6-----	11½	2	.113	.0380
7-----	11½	2¼	.113	.0380
8-----	10¾	2½	.131	.0474
9-----	10¾	2¾	.131	.0474
10-----	9	3	.148	.0570
12-----	9	3¼	.148	.0570
16-----	8	3½	.162	.0652

**Lateral resistance.**—In determining lateral resistance of a nail, the specific gravity or density of the wood, as well as the nail diameter, must be considered. The formulas used to determine the lateral resistance are based on the penetration of an uncoated, circular shank nail into the main member two-thirds of its length in low-density woods and one-half of its length in high-density woods. For their maximum holding capacity, nails should therefore be long enough to penetrate these distances.

The following formulas can be used for determining the allowable lateral resistance of nails driven into the side grain of various kinds of wood. The values are based on stresses normally placed on crates.

TABLE 8.—Average allowable loads<sup>1</sup> for nails in direct withdrawal<sup>2</sup> (nails equal in diameter and length to sinker nails)

Wood species	Allowable load					
	Six-penny	Eight-penny	Ten-penny	Twelve-penny	Sixteen-penny	Twenty-penny
	<i>Lb.</i>	<i>Lb.</i>	<i>Lb.</i>	<i>Lb.</i>	<i>Lb.</i>	<i>Lb.</i>
Basswood, cottonwood, true firs, pines (except southern yellow), spruce, yellow-poplar, and other species of similar density	18	27	35	42	49	58
Western hemlock, red pine, redwood, other species of similar density	25	37	48	58	66	79
Soft elm, sweetgum, black ash, soft maple, other species of similar density	34	51	66	81	93	111
Douglas-fir, western larch, southern yellow pine, other species of similar density	38	56	73	89	102	121
White ash, beech, birch, hard maple, oaks, rock elm, other species of similar density	59	88	114	140	159	190

<sup>1</sup> Based on normal conditions for crates.<sup>2</sup> When driven in side grain of seasoned lumber to a depth equal to two-thirds of its length.

<i>Species</i>	<i>Formula</i>
Basswood, cottonwood, true firs, pines (except southern yellow), spruces, yellow-poplar, other species of similar density	$P = 1,080D^{3/2}$
Western hemlock, red pine, redwood, other species of similar density	$P = 1,350D^{3/2}$
Soft elm, sweetgum, black ash, soft maple, other species of similar density	$P = 1,500D^{3/2}$
Douglas-fir, western larch, southern yellow pine, other species of similar density	$P = 1,650D^{3/2}$
White ash, beech, birch, hard maple, oaks, rock elm, other species of similar density	$P = 2,040D^{3/2}$

In these formulas,  $P$  is the allowable load per nail in pounds and  $D$  is the diameter of nails in inches.

The values for  $D^{3/2}$  for the various sizes of nails are given in table 7.

For convenience of the crate builder, table 9 covers the average allowable loads for sinker nails in lateral resistance. This table is satisfactory for sinker nails or nails of equal diameters in crates under normal storage and handling conditions.

*Nailing rules.*—The following good nailing methods and general rules are used in the fabrication and assembly of crates. Many are based on the engineering analysis of holding capacity of nails, while others are based on practices found to be satisfactory.

1. Unless nails are clinched, use cement-coated, etched, or deformed-shank nails to gain increased

TABLE 9.—Average allowable loads for nails in lateral resistance<sup>2</sup> (nails with diameters equal to sinker nails)

Wood species	Allowable load					
	Six-penny	Eight-penny	Ten-penny	Twelve-penny	Sixteen-penny	Twenty-penny
	<i>Lb.</i>	<i>Lb.</i>	<i>Lb.</i>	<i>Lb.</i>	<i>Lb.</i>	<i>Lb.</i>
Basswood, cottonwood, true firs, pines (except southern yellow), spruce, yellow-poplar, other species of similar density	30	41	45	54	62	81
Western hemlock, red pine, redwood, other species of similar density	37	51	57	67	77	101
Soft elm, sweetgum, black ash, soft maple, other species of similar density	42	57	63	75	86	112
Douglas-fir, western larch, southern yellow pine, other species of similar density	46	63	69	82	94	123
White ash, beech, birch, hard maple, oaks, rock elm, other species of similar density	56	78	85	101	117	152

<sup>1</sup> Based on normal storage and handling conditions.<sup>2</sup> When driven in side grain of seasoned lumber, minimum distance of penetration equal to two-thirds of its length in the softer woods or one-half in the denser woods.

withdrawal resistance. Nails used for assembling crates should have a diameter at least equal to that of a sinker nail (table 5) and a strong head of moderate size to prevent the head from shearing off or pulling through the wood.

2. In the fabrication of panels for sheathed crates, it is desirable to hold the members in alinement while the sheathing is applied. This may be done by jigs or by fastening frame members to each other with corrugated fasteners or staples before the sheathing is applied.

3. Whenever possible, nails should be driven through the thinner piece into the thicker. This is especially important when plywood is fastened to nominal 1- or 2-inch members.

4. When nailing two pieces of lumber together flatwise, as in fabrication, the nails should be clinched if the combined thickness is 3 inches or less. A  $\frac{1}{4}$ -inch minimum clinch should be used for nails up to sevenpenny, a  $\frac{3}{8}$ -inch clinch for eightpenny through twelvepenny nails, and a  $\frac{1}{2}$ -inch clinch for larger nails. Plywood 36 inches or less in thickness may be nailed to nominal 2-inch members without clinching if the nails penetrate  $1\frac{1}{2}$  inches into the members.

5. Nails are not clinched when the combined thickness of two pieces of lumber nailed together flatwise is more than 3 inches, or when the flat face of one member is nailed to the edge of another. Tenpenny and smaller nails should penetrate into the piece for a distance equal to about 2 to  $2\frac{1}{2}$  times the thickness of the piece holding the nail-head. Twelvepenny and larger nails should penetrate at least  $1\frac{1}{2}$  inches into the piece that holds the point.

6. If diamond-point nails split the wood enough to weaken it, the points should be blunted slightly. If blunting does not prevent the splitting, nails of the next smaller penny size should be used and spaced a little closer together. Drilling lead holes also will reduce splitting. Except for very large members, predrilling is recommended for twenty-penny nails and larger.

7. Nails generally should be driven no closer to the edge of a piece than one-half its thickness and no closer to the end than the thickness of the piece. Smaller nails can be driven closer to the edges or ends than larger ones because they are less likely to split the wood.

8. To decrease splitting, nails should be driven in two or more rows whenever possible, or staggered slightly within the row when one row is used.

9. When nailing two pieces of lumber together flatwise and at right angles to each other, nailing patterns similar to those shown in figure 6 should be used. These patterns should also be used when nailing a piece of lumber flatwise to another or to the face of a larger frame member. The patterns are adaptable to both fabrication and assembly nailing.

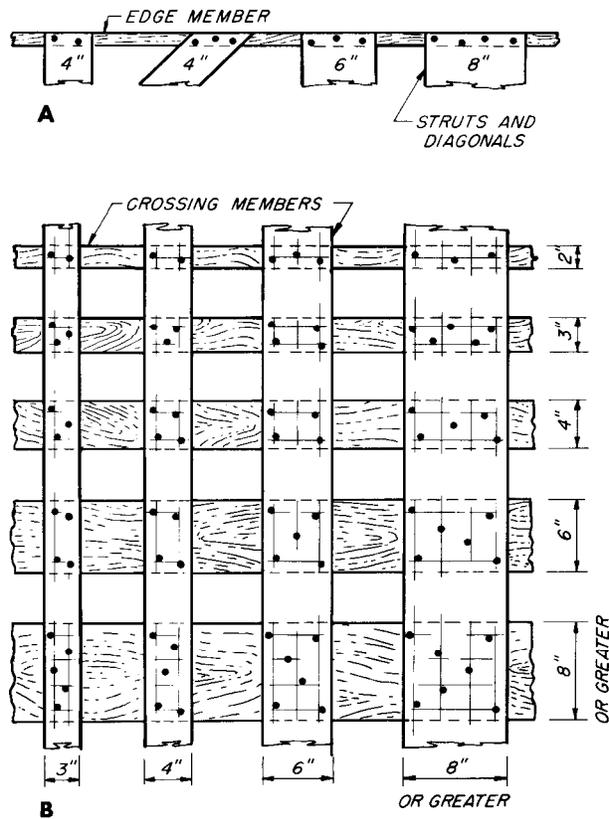

M-119867

Figure 6.—Typical nailing patterns in open crates: A, Nailing for assembly of panels to each other; B, nailing for fabrication of panels, as used to nail floorboards to skids and lumber sheathing to frame members.

10. When nailing plywood to struts or other members in fabrication (fig. 7), nails should be spaced not more than 3 inches on center and staggered in rows not less than  $\frac{3}{4}$  inch apart. The farther apart the rows, the greater the racking resistance of the joint.

11. When attaching two members so their grain is parallel, such as sheathing to struts, the number of rows of nails is usually determined by the width of the surface in contact. One row of nails is used for widths of 2 inches and less, two rows for widths over 2 inches and less than 6 inches, and three rows for widths 6 inches and over.

12. When nailing a 1-inch-thick frame member flatwise to a 2-inch-thick member to form a laminated beam or similar combination, sevenpenny nails are used with the heads placed in the thinner member. Two rows are used for 4- and 6-inch pieces and three rows for wider pieces. The nails are spaced about 16 inches apart in the rows. Stagger them between rows. Longer nails may be used and clinched about  $\frac{3}{8}$  to  $\frac{1}{2}$  inch. Nails should be about 1 inch from the edges.

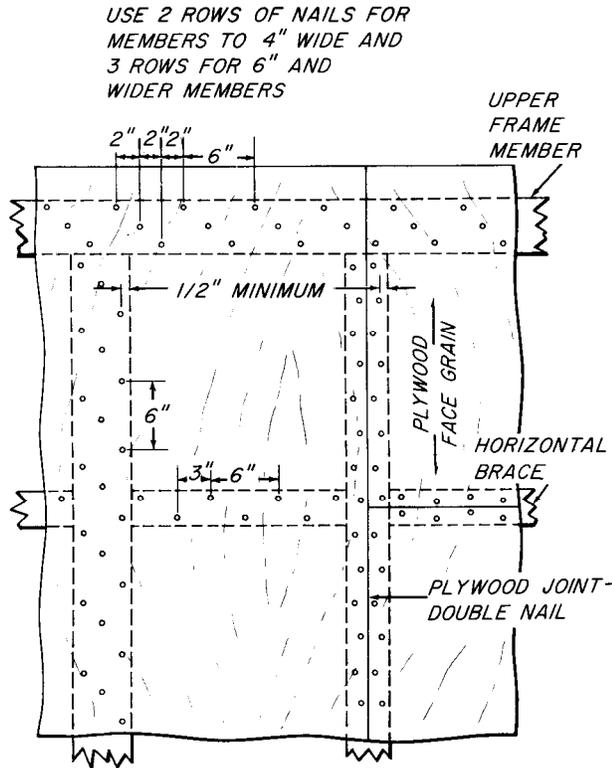

M-119668

Figure 7.—Typical nailing patterns for fastening plywood sheathing to frame members.

13. When nailing two 2-inch-thick members together flatwise, as for laminated joists or beams, twelvepenny nails should be used. Nails are placed 1 to 1½ inches from the edges of the members, depending on their width, and approximately 16 inches apart in the rows. Two rows of nails should be used for members 4 to 6 inches wide and three rows for wider members. Nails in each row are driven alternately from opposite sides of the pieces and staggered between rows.

14. When three 2-inch-thick pieces of lumber are to be nailed together, first two pieces are nailed together with twelvepenny nails spaced and located as described in rule 13, except that all nails are driven from the same side. The third piece should be nailed with twelvepenny nails to the piece that contains the nail points. The nails are spaced about midway between the points of the first nails.

15. In fabrication of lumber-sheathed crate panels, at least two nails should be driven through each sheathing board into each member it crosses. In assembly, also, at least two nails should be used to fasten each sheathing board to each fastening member, including skids.

16. When two pieces of plywood sheathing are butt-jointed, the joints should be positioned at

the center of a vertical or horizontal frame member. The abutting edge of each sheet of plywood is nailed with two rows of clinched nails, and the nails are staggered between rows.

## Lag Screws

Lag screws are most commonly used in crate construction for assembly of the panels, particularly in fastening sides and ends to the base. Their use allows the crate to be fully or partially demountable. Lag screws have excellent direct-withdrawal and lateral resistance and are often used in crates where high stresses occur in handling.

Two types of lag screws are commonly used: (1) The cut lag screw, which has a thread diameter the same size as the shank; and (2) the rolled or pressed lag screw, the threaded portion being larger in diameter than the shank. The cut lag screw is perhaps the most common type used in crate assembly. Lag screws used in crate construction vary from ¼ to ¾ inch in diameter and are from 2 to 6 inches long. The threaded portion covers about two-thirds of the length in these sizes.

The lateral and withdrawal resistance of a lag screw depends principally on the contact of the lag screw threads with the wood. Lead holes are drilled before lag screws are started, and the size of these holes is important to insure maximum contact without splitting the wood (fig. 8).

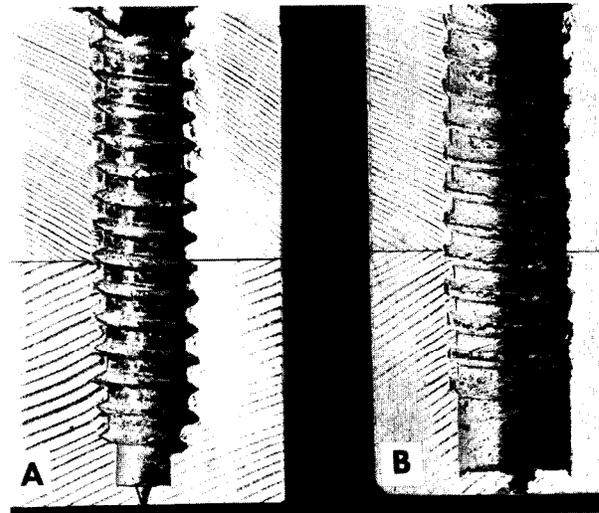

M-119663

Figure 8.—A, Lag screw lead hole of proper size results in deep thread penetration and maximum resistance to withdrawal; B, an oversized lead hole results in shallow penetration of lag screw thread and poor withdrawal resistance.

Drill the entry hole, the same diameter as the shank, through the member or assembly to be fastened. The size of the lead hole in the receiving member varies and depends on the density of the

wood as well as the outside diameter of the lag screw at the threads. The combined depth of the entry and lead holes should equal the total length of the shank and threaded portions. The size of the lead hole for lag screws should follow the recommendations in table 10.

TABLE 10.—Diameters of lead holes and  $D$  values for various sizes of lag screws

Lag screw diameter	Lead hole diameter in wood of		Values		
	Groups I, II, III	Group IV	$D$	$D^2$	$D^{3/4}$
<i>In.</i>	<i>In.</i>	<i>In.</i>	<i>In.</i>	<i>In.</i>	<i>In.</i>
1/4	3/16	3/16	0. 250	0. 0625	0. 354
5/16	1/4	1/4	. 3125	. 0975	. 418
3/8	1/4	5/16	. 375	. 1406	. 479
1/2	3/8	1/2	. 500	. 2500	. 595
5/8	3/8	1/2	. 625	. 3906	. 703
3/4	1/2	3/4	. 750	. 5625	. 806

*Direct-withdrawal resistance.*—Penetration of the threaded portion of about 7 times the shank diameter in the denser species and 10 to 12 times in the softer species will develop approximately the ultimate tensile strength of the screw in direct withdrawal.

The allowable load for lag screws in direct withdrawal from the side grain of seasoned wood may be determined from the following formula:

$$P=1,800 G^{3/2} D^{3/4}$$

where  $P$  is allowable load in pounds per lineal inch of penetration of the threaded portion of the lag screw into the member receiving the point;  $D$  is shank diameter of the lag screw in inches; and  $G$  is specific gravity of oven-dry wood (table 6).

For convenience of the crate designer, table 10 covers the sizes of lag screws that might be used in the formula.

*Lateral resistance.*—Allowable loads for lateral resistance are ordinarily based on a minimum penetration of the threaded portion of the lag screw into the main member. This penetration varies from 11 times the shank diameter for the softer woods to 7 times the shank diameter for the harder woods. The assumed thickness of the side member is 3.5 times the shank diameter of the lag screw, and the length of the shank is assumed to be equal to the thickness of the side member.

The equations for computing the allowable lateral loads in pounds, parallel to grain, for lag screws screwed into side grain of various species of wood are:

Species Formula  
 White-cedar, white fir, eastern hemlock, soft pines, spruce, other species of similar density.  $P = 1,800 D^2$

Aspen, basswood, cottonwood, Douglas-fir (mountain), western hemlock, redwoods, yellow-poplar, other species of similar density.  $P = 2,040 D^2$

Black ash, soft elm, gum, larch, soft maple, Douglas-fir (coast), southern yellow pine, other species of similar density.  $P = 2,280 D^2$

White ash, beech, birch, rock elm, hickory, hard maple, oaks, other species of similar density.  $P = 2,640 D^2$

$P$  equals allowable load per lag screw in pounds.  $D$  is shank diameter of the lag screw in inches.

Allowable lateral loads perpendicular to grain are somewhat lower. This reduction factor varies from 85 percent for 5/16-inch-diameter lag screws to 60 percent for 5/8-inch-diameter lag screws.

*Rules for use.*—The following general methods will aid the crate builder in properly placing and using lag screws:

1. A plain flat washer or other reinforcing device should be used under the head of each lag screw. The washer prevents the lag screw head from cutting into the wood and reinforces the area around the entry point.

2. To obtain good withdrawal resistance, a lead hole for the threaded portion of each lag screw should be drilled according to the sizes shown in table 10. The entry hole should be the same diameter as the shank. One method consists of drilling the shank entry holes in the prefabricated panels during construction and the lead holes for the threaded portion during assembly. A split-shank countersink, when available, allows the lead and entry holes to be drilled in one operation.

3. Lag screws should be turned the full distance into their holes. Partial driving strips the wood threads and reduces the holding capacity of the lag screws. If the wood threads are stripped the lag screw should be placed in a new location. A power impact tool will turn lag screws in quickly and uniformly.

4. Lag screws should not be countersunk. Countersinking reduces the cross section of the first member entered and weakens the joint.

5. The required number of lag screws to fasten the sides of a crate to the base is determined by dividing the gross weight of crate and contents by the allowable lateral load per lag screw.

6. The size of lag screw is selected on the basis of the size of the skid or fastening member used. Lag screws 1/4 or 5/16 inch in diameter are used for

small crates with 2-inch-thick members;  $\frac{3}{8}$ -inch lag screws for S-inch-thick members;  $\frac{1}{2}$ -inch lag screws for 4-inch-deep skids; and  $\frac{5}{8}$ -inch and larger lag screws for 6-inch and deeper skids.

### Bolts

Bolts are used in various phases of crate construction, and the type selected should be governed by the location in the crate. Machine bolts are often used in the blocking and bracing phases of packaging, where they are especially useful in anchoring the contents to the base. Any bolt that may be removed occasionally should be a machine bolt, so that both ends may be fitted with a wrench. On the other hand, bolts that will not have to be removed preferably should be carriage or step bolts. Carriage and step bolts are used to fasten the heavier end headers and floorboards to the skids. Both carriage and step bolts are so designed that no washer is required under the head. Furthermore, these bolts can be placed head side down in a skid and cause no interference in skidding because the shape of the head prevents snagging.

Occasionally it is desirable to use a removable bolt where its nut would be inaccessible with a wrench. Available for such cases are special bolt-nut combinations, sometimes called barrel bolts, in which the nut is fastened in the end of a sleeve. The sleeve is placed in a predrilled hole in a block or skid, and the bolt engages the nut through the sleeve. For these bolts the holes must be located accurately so that no difficulty occurs in assembly.

In some types of construction, such as the wood truss, bolts are in double shear—used with three members. Ordinarily the stress in the outside two members is in one direction and the stress in the center member is in another direction. In crate construction where bolts are used to fasten the side panel to the skid of the base, the bolts are in single shear rather than double.

Load values for bolts in single shear are ordinarily only slightly greater than the lateral resistance loads described for lag screws. Equations and other data in the preceding section may apply for bolts of equal diameter. Specific load values for different bolt diameters and species of wood may be obtained in National Design Specifications.<sup>4</sup>

In order to obtain full design strength, the application of bolts is important. Holes of the same diameter as the shanks of the bolts should be prebored. A hole so small that the bolt must be driven forcibly may mean the wood will be split. Plain washers should be used under

<sup>4</sup> National Lumber Manufacturers Association. National design specifications for stress-grade lumber and its fastenings. 64 pp., illus. 1962.

the nuts of all types of bolts and under the heads of machine bolts. After tightening the nut, paint the threads projecting beyond it with unthinned lead paint, or use another locking device to prevent the nut from turning.

The heads of all bolts should be on the outside of crates. They are less likely to cause interference than the nut ends. This is especially true on the underside of skids, where the round head of the carriage or step bolt causes no troubles during skidding. Countersinking bolts reduces the cross section and strength of the member.

When a reusable crate is designed, nut-sleeve and bolt combinations instead of lag screws are often desirable to fasten the sides and ends to the base. This method of assembly will allow the crate to be reused a number of times without loss of holding power. The spacing should be the same as used for lag screws.

The following methods are recommended in the use of bolts:

1. Carriage or step bolts should be used, head down, to fasten the skids to cross members.
2. Boltholes should be drilled the same diameter as the bolt shank. Place washers under all nuts and under the heads of machine bolts.
3. Turning or loosening of the nut, due to vibration should be prevented with a heavy lock washer, a lock nut, or a double nut, or by painting the thread beyond the nut with unthinned white lead or similar material.
4. At least one bolt should be used at the end of each end header and other members over 2 inches thick that are not more than 4 inches wide, and two bolts for members over 4 inches wide. Where intermediate skids are used, end headers and load-bearing floorboards should also be bolted to them.

### Timber Connectors

Connectors consist generally of metal rings or plates that are embedded partly in two adjacent members. These connectors transmit the shear loads from one member to the other with an action similar to a dowel or a key.

Most adaptable to crate assembly are the connector plate and the toothed-ring connector shown in figure 9. They are pressed into each member by turning the bolt or lag screw at the center of the connector. (The lag screws used with connectors should have cut threads rather than pressed threads. Their penetration into the receiving member should be from five to nine times the diameter of the shank.)

Tables and formulas in the Wood Handbook<sup>5</sup> may be consulted to determine the allowable loads for the toothed-ring and other types of connectors.

<sup>5</sup> See footnote 1, p. 5

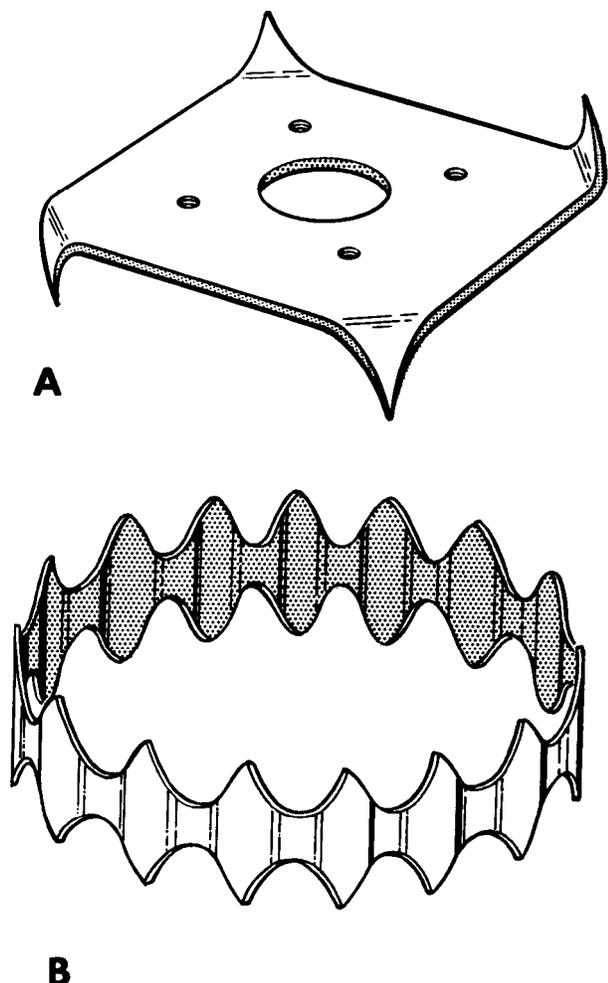

M-119666

Figure 9.—Types of connectors for heavy crates: A, Connector plate; B, toothed-ring connector.

However, it is generally assumed that a safe load to assign to a 2-inch connector is about twice the safe load of a lag screw alone.

The most logical use for connectors is in the assembly of the sides to the base and top of very heavy sheathed and open crates. In this use they replace the lag screw connections that are ordinarily used for, assembly.

### Wood Screws

Wood screws may be used as a substitute for nails where demountability is desired in lightweight crates. They may also be used where plywood or metal gusset plates must be fastened to thin members in blocking and bracing, and nails are not practical. Depending on their size and length, screws usually have a higher withdrawal resistance

than nails. Because screws are not a common means of fastening in crates, design data are not included here. The Wood Handbook contains design data for screws.

### Adhesives

Although adhesives are not commonly used in crate construction, they are sometimes used in conjunction with nails for small, reusable plywood containers. The nails apply pressure on the glue until it has set and are left in place. Where moisture content of the wood is not controlled the application of glue has not been successful. Most glues dry slowly without heat and require some pressure during drying. However, advances are being made in adhesives research, and it appears possible that contact and fast setting adhesives will be developed for use in certain phases of crate construction.

### Steel Strapping

Steel reinforcing strap is commonly used on sheathed crates that are intended for export shipment. Its major purpose, in most styles of crates, is to reinforce the nailed corners and edges (fig. 10). It is seldom used for crates with lag screw assembly except when they contain very heavy loads. The corners and edges of open crates might also be reinforced with strapping if loads are extremely heavy or severe handling is anticipated. However, because open crates are most often used for domestic shipments, the strapping is not usually required. Certain types of strapping may be used as bracing or hold-down strapping for the item.

Two general types of steel strapping, nailless and nail-on, are suitable for use on crates. Nailless strap is a tension strap, applied with a tension tool and sealed with metal crimp-on seals. It must encircle the container or, on most crates, be fastened to anchor plates on each side and tensioned to fasten the top in place. Nail-on strapping is annealed and may be nailed through the strap, although it is more often prepunched.

Strapping is supplied with either a coated or uncoated finish. When high resistance to rusting is required, zinc-coated strap is recommended, and the seals or nails used should also be rust resistant.

Some of the points worthy of consideration in applying strap are:

- (1) Each leg of the strap should be at least 6 to 8 inches long.
- (2) For each leg three nails, preferably 1¼ to 1½-inch roofing nails, should be driven 1½ to 2 inches apart.
- (3) Nailing should always be into a frame member.
- (4) Strapping and nails should be rust resistant.
- (5) Corner strapping along edges should be spaced about 36 inches apart.

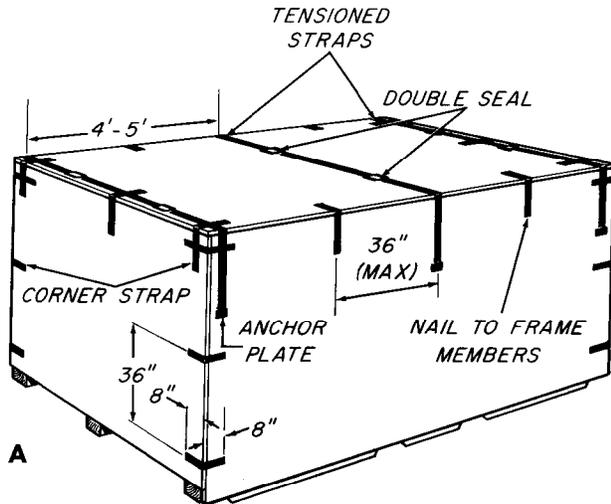

A

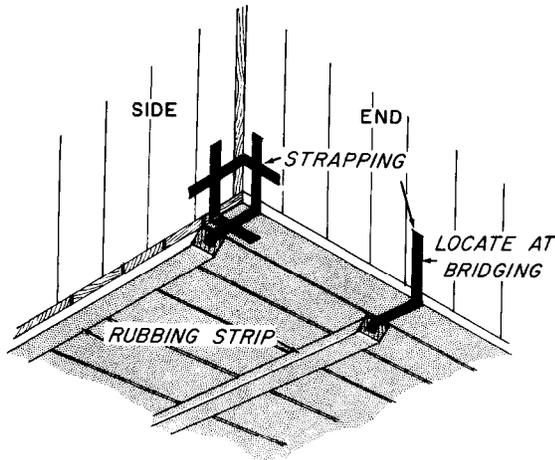

B

M-119682

Figure 10.—Strapping for crates: A, Sheathed crate with skid base; B, additional strap for sill-type base.

(6) Tension strapping should be spaced a maximum of 5 feet apart.

(7) The tension strap should not be less than  $\frac{3}{4}$  inch wide by 0.028 inch thick for gross loads up to 10,000 pounds, and  $1\frac{1}{4}$  inches wide by 0.025

inch thick for gross loads over 10,000 pounds. Corner reinforcing strap (annealed) should not be less than  $\frac{3}{4}$  inch wide by 0.028 inch thick for gross loads up to 20,000 pounds, and  $1\frac{1}{4}$  inches by 0.025 inch for gross loads over 20,000 pounds.

Certain types of strapping may also be used to reinforce the sheathing where it is fastened to the base with lag screws (fig. 11). This lag screw-reinforcing strap increases the shear resistance of the sheathing and results in greater lateral resistance for the lag screws.

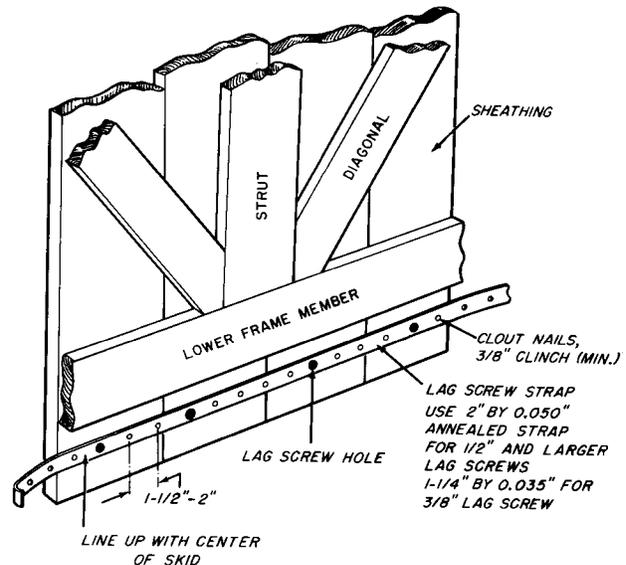

M-119669

Figure 11.—Proper use of lag screw-reinforcing strap.

When the crate is assembled, the strap is aligned with the center of the skids and end header. Nails are spaced  $1\frac{1}{2}$  to 2 inches apart and are clinched on the outside face of the sheathing. One satisfactory method of using this strap is to predrill the holes for the lag screws before the strap is placed and nailed.

The strap should be  $1\frac{1}{4}$  inches by 0.035 inch for lag screws  $\frac{3}{8}$  inch or less in diameter. For lag screws  $\frac{1}{2}$  inch or more in diameter, the strap should be a minimum of 2 inches by 0.050 inch.

## DESIGNING CRATES

After considering the requirements and materials the crate designer next decides what size the members should be, how to arrange them, and other construction details.

Each component of a crate (base, sides, ends, and top) has a definite function. The items or contents are placed on the crate base, which sustains the load on sills or other load-bearing mem-

bers and transfers the load to the side panels. The sides are assembled to the base and carry the load of the base as well as resist the top load superimposed by other containers stacked on the crate. Ends of crates are crossties because they tie the sides together, add racking resistance, and are a safety factor for resisting top loads. The top panel serves as a cover, a means of tying end

and side panels together, and also as a support for top loading. Proper combination and fastening together of these units or panels is necessary to develop full strength of the crate.

## IMPORTANCE OF DIAGONALS

Forest Products Laboratory research has brought out the importance of diagonal members and their proper orientation and location. The closer the angle of the diagonals with respect to the horizontal members is to  $45^\circ$ , the greater is the racking resistance of the panel. When loads are applied to the corners of open crates, the stress in each member is dependent upon its length, as well as upon the distance to the diagonally opposite corner. The more nearly a cube the crate becomes, the more even are the stresses in each member. The ultimate in crate design is one in which all the diagonals are at an angle of  $45^\circ$  to the other members.

The following principles are important to the crate designer:

1. Two diagonals crossing each other make each panel considerably stronger than does a single diagonal.

2. All faces of the crate should be braced with diagonal members, unless the crated item can resist torsional stress or is suspended freely in the crate.

3. When all of the crate faces are braced and the item is properly supported, racking of the contents cannot take place until the crate has failed.

4. If a crate has only five faces braced diagonally and is loaded on diagonally opposite corners or is stressed by any method that allows distortion to the unbraced face, all faces will twist very much alike. However, the diagonal distortion will be concentrated largely in the unbraced face and will be many times that of the braced faces. When all six faces are diagonally braced, both the twisting and diagonal distortion are quite uniform throughout the crate.

5. When one or more faces of a crate are not braced diagonally the contents can be racked without crate damage because of the extreme distortion in the unbraced face or faces.

Many times the contents of a large crate are found to be damaged even though the crate itself is apparently in good condition. In these instances the crate was distorted, the contents were damaged, and then the crate returned to its normal shape.

## DESIGN PRINCIPLES

Based on a mathematical analysis of crate members and panels, construction methods and the sizes of members were determined for the majority of crate types for both domestic and overseas shipments. The crate analysis was then

verified by rough-handling and stacking tests of crates built according to these criteria. This information has been converted to tables and plans for use by the designer. A discussion of the theory and methods of analysis is presented here.

In a mathematical analysis of a crate man components of the crate panels are included. Standard beam formulas are used to determine the sizes of joists and load-bearing floorboards. Both are calculated to span the width of the crate. Even though floorboards are fastened to intermediate skids, because of certain methods of handling the effective span must be considered as the distance between the outside skids.

The sides and ends, as well as some members of the base, are considered as parts of a bridge truss. The sizes of members are determined by analyzing this truss. The Howe truss, with its parallel upper and lower chords and its vertical and diagonal members, has the same general pattern as the frame members of the side of a lumber-sheathed crate (fig. 12). Since the truss is a framed structure composed of straight members, the stresses in the members due to loads must be either compression or tension. The magnitude and character of the stress in each member can be determined by the graphic method. This involves solving a series of stress diagrams of the triangles that make up the truss, using T-square, triangles, and scale. The sizes of the various members can be determined by using equations based on stresses found with the diagrams.

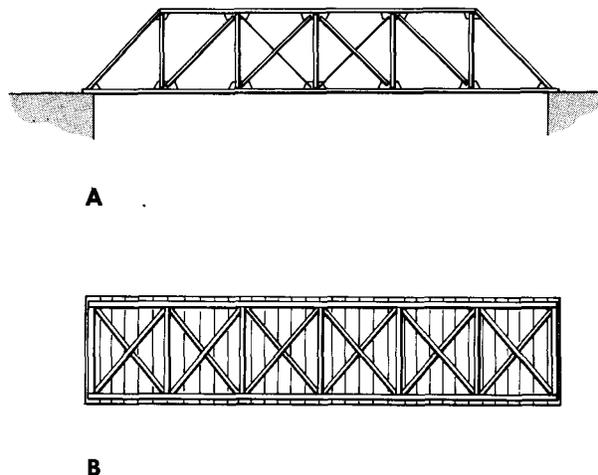

M-119664

Figure 12.—Comparison of: A, Howe truss with parallel chords, B, side panel of sheathed crate.

This method of analysis allows a skid member to be considered as a part of the lower frame, since sides are effectually fastened to the base at assembly. Thus the skid sizes necessary are greatly reduced. Designing the skids as beams without considering the sides would result in

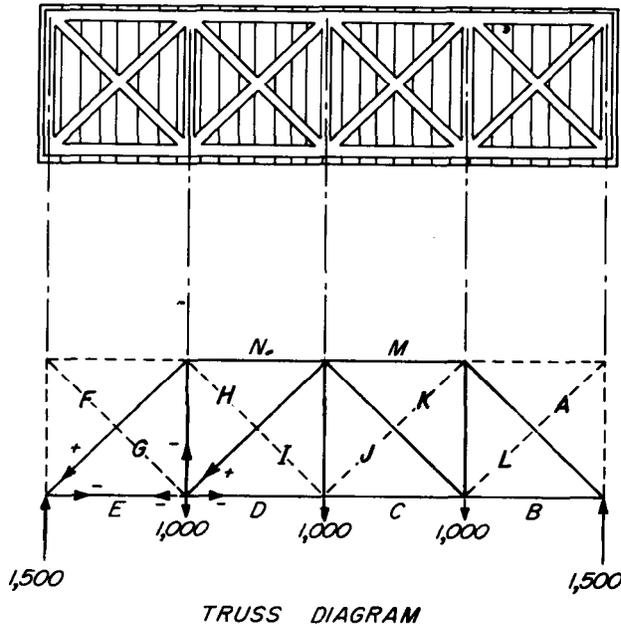

<u>MEMBER</u>	<u>TYPE OF STRESS</u>	<u>STRESS IN POUNDS</u>
FG	COMP.	2,100
GE	TENS.	1,500
GH	TENS.	1,500
HI	COMP.	700
ID	TENS.	2,000

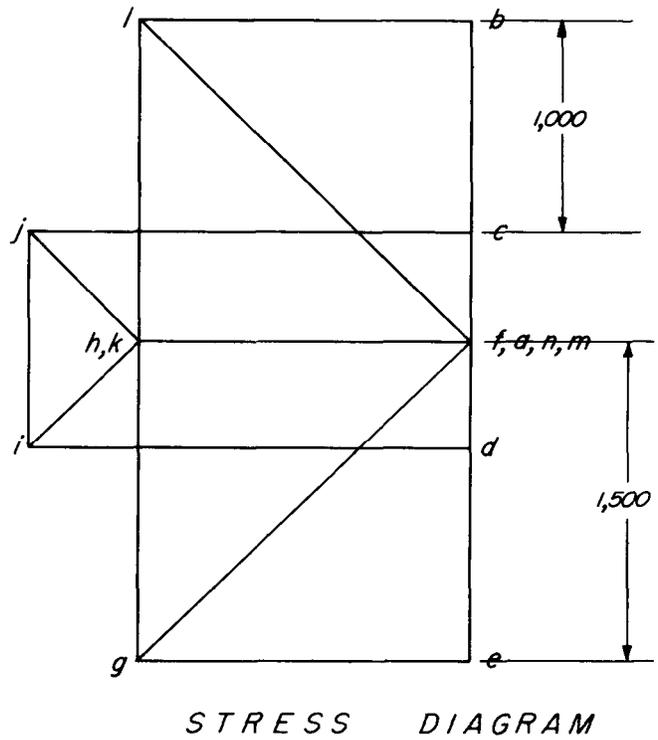

M-119665

Figure 13.—Truss and stress diagrams used to determine the magnitude and character of stress in each member of the side of a crate.

unnecessarily large members, with greater cost, weight, and cubic displacement.

A timber truss is fabricated with bolts and timber connectors. The sides and ends of crates are held together by sheathing, joined to each frame member by a series of clinched nails. This panelized fabrication provides a strong, rigid framework. When the sides are combined with the base, ends, and top, the resulting trussed structure can support a variety of loads.

Through the use of column formulas, the sides of the crate are examined for adequacy to support superimposed loads. This method also is discussed.

### Truss Diagram

The graphic method of solving for stresses in members of sides of crates can be best illustrated by a specific example. The truss diagram and the stress diagram are used together for determining the character and magnitude of the stresses in the crate members under a typical loading condition. The upper diagram in figure 13 shows the side of a lumber-sheathed crate with its diagonals, struts, and upper and lower longitudinal members. Directly below the side panel is a truss diagram—a line drawing scaled to be identical with the centerline of each frame member of the crate. The truss diagram shows the crate supported at each end, as it is when the crate is lifted with a pair of slings. The solid lines indicate the members that are stressed under these loading conditions, and the broken lines are those for which no stress is considered. A member is defined by the letters of the two areas it separates. If the crate is supported at the center by a single set of grabhooks or by a forklift truck, the loading conditions are reversed.

It is assumed that the crate and contents weigh 6,000 pounds. Half, or 3,000 pounds, is carried by each side panel. Assuming uniformly distributed loading, the 3,000 pounds are evenly divided between the four panels of the side. For ease of analysis, it is assumed that 1,000 pounds (downward forces) are assigned to each of the three center panel points, with each end supporting 1,500 pounds (upward forces) as shown in the truss diagram. The next step is to assign a letter to each area of the diagram as shown, so that a force diagram can be outlined for each set of member intersections. A joint is defined by the letters of the three or four areas next to it.

### Stress Diagram

The actual stress diagram is started by laying out to an appropriate scale (in pounds) all vertical forces represented by the vertical loadline *eb*, as shown on the stress diagram (fig. 13). Thus the

reactions of 1,500 pounds each are *ef* and *ab*, both upward forces. The downward forces of 1,000 pounds each represented by *bc*, *cd*, and *de* are scaled and marked on the same vertical line as shown. The total downward forces of 3,000 pounds now equal the total upward forces of 3,000 pounds.

A stress diagram may now be drawn for the members *FG* and *GE* which intersect at the left reaction point on the truss diagram. Clockwise around the left reaction point are three forces: *EF* (the reaction), a known upward force of 1,500 pounds; *FG* (the diagonal force); and *GE* (the horizontal force). *FG* and *GE* are of unknown magnitude. Because these forces are in equilibrium, the lines in the stress diagram corresponding to the forces must meet. Therefore, moving to the vertical load line of the stress diagram and starting at point *e*, there is an upward force of 1,500 pounds to point *f*. From *f* a line is drawn down and to the left diagonally which is exactly parallel to member *FG* on the truss diagram. Since the diagram must close, a horizontal line drawn on the stress diagram from point *e* and parallel to *GE* on the truss diagram to the intersection of the diagonal line will form point *g*. This will close the triangle and solve the stress diagram for the intersection. The result is a triangle composed of lines *ef*, *fg*, and *ge*. The magnitude of the stress designated by *ef* is known (1,500 pounds). By scaling the length of lines, the magnitude of the stress *fg* is found to be 2,100 pounds; *ge*, 1,500 pounds.

The next stress diagram to be developed is one at the intersection of members *GH*, *HI*, *ID*, and *EG*. The magnitudes of the stresses at this intersection are determined in the same manner. Thus *gh* (1,500 pounds), *hi* (700 pounds), and *id* (2,000 pounds) are determined by progressing clockwise around the joint. The entire stress diagram is then drawn by solving each of the other six intersections.

The magnitude of the stress in each member is known, so the character of stress (compression shown as + or tension as -) must be found. For example, to determine the character of the stresses at the first joint examined (left reaction point), both the truss diagram and the stress diagram must be referred to. Using the clockwise system in the truss diagram for member *FG* and proceeding from *f* to *g*, the direction of the line in the stress diagram is downward and to the left. This direction is then transferred to the truss diagram on member *FG* and a small arrow placed on this line toward the joint or reference point. The member is indicated as in compression with +, since forces toward the joint produce compression stresses in the member. Similarly, for the *GE* member, the *ge* line direction is to the right; when transferred to the truss diagram, it is away from the reference point and

the member is in tension, shown by -. The character of stress in each member in the truss is then determined in a like manner. The information on the magnitude and character of stresses in the members may be placed in a table for the convenience of the crate designer. These stresses were used in determining the size of members required under the loading conditions outlined.

### Determining Size of Members

The next phase in the analysis is to determine the sizes of members based on the magnitudes of the stresses found by developing the stress diagram. Inasmuch as there are both compression and tension stresses in the various members, working stresses for each kind must be selected, allowing for most general conditions.

*Tension members.*—The required size of all tension members in the truss is determined by the formula

$$A = \frac{P}{f} \quad (1)$$

where  $A$  is the required cross sectional area of the member in square inches,  $P$  equals total load in pounds (from stress diagram), and  $f$  is the working stress in pounds per square inch (in tension parallel to grain).

For example, the magnitude of stress in a tension member is 5,500 pounds, which has been determined from solution of a stress diagram, similar to the one shown in figure 13. The working stress for the species used is assumed to be 1,000 pounds per square inch. Then the net cross sectional area required is

$$A = \frac{P}{f} = \frac{5,500}{1,000} = 5.5 \text{ square inches}$$

The net area of a nominal 2- by 4-inch member (actually  $1\frac{5}{8}$  by  $3\frac{5}{8}$  inches) is approximately 5.9 square inches. Therefore, a 2 by 4 is satisfactory.

*Compression members.*—With supports at each end as in the truss diagram (fig. 13), the major stresses in the struts and lower frame members are tension stresses and those in the diagonals and upper frame members are compression stresses. Therefore, the compression members (diagonals and upper frame members) must be designed as columns and the column formulas used to determine their sizes.

The slenderness ratio  $\frac{L}{d}$  (length of member in inches divided by the least dimension) of each compression member must be calculated in order to decide which column formula to use. The effective thickness (or at least dimension) for computing  $\frac{L}{d}$  is based on the assumption that the

thickness of the sheathing is added to the thickness of the frame member.  $L$  is equal to the length of each member in inches of clear span (distance between its intersection with other members).

For example, assume the actual least dimension of the member to be  $1\frac{5}{8}$  inches, to which is added the thickness of the sheathing,  $\frac{3}{4}$  inch, for a total  $d$  of 2.375. Assume the length to be 24 inches, then the slenderness ratio is

$$\frac{L}{d} = \frac{24}{2.375} = 10.1$$

*Short columns.*—Usually a short column is one that has an  $\frac{L}{d}$  ratio of 11 or less. Bending is not considered in calculating its capacity to carry loads, and the full safe unit compression stress may be used. Therefore, the formula used to determine the capacities of short columns is as follows:

$$A = \frac{P}{c} \quad (2)$$

where  $A$  represents the required area of the member in square inches,  $P$  is total load in pounds (from stress diagram), and  $c$  equals working stress in pounds per square inch (compression parallel to grain). Thus the size of members can be calculated directly using the full safe unit compressive stress and the total load.

*Intermediate columns.*—Intermediate columns are usually considered as those that have an  $\frac{L}{d}$  ratio over 11 but less than the value of  $K$ . The value of  $K$  is sometimes considered as 22.4, but the method used to determine this factor is also included. The recommended formula for use under these conditions is as follows:

$$\frac{P}{A} = c \left[ 1 - \frac{1}{3} \left( \frac{L}{Kd} \right)^4 \right] \quad (3)$$

where  $P$  equals total magnitude of stress in pounds,  $A$  is required net area in square inches,  $c$  is safe unit compressive stress in pounds per square inch,  $L$  is unsupported length or height of member in inches,  $d$  is least dimension in inches, and  $K$  is approximately 22.4.

For an exact value of  $K$ , use the formula:

$$K = 0.64 \sqrt{\frac{E}{c}} \quad (4)$$

where  $E$  represents modulus of elasticity (in pounds per square inch) for the species used.

As an example of determining the size of a single compression member with an  $\frac{L}{d}$  ratio be-

tween 11 and 22.4, assume  $P$  is 5,500 pounds,  $c$  equals 1,000 pounds per square inch,  $L$  represents 35 inches,  $d$  is  $1\frac{5}{8}$  inches, and  $E$  equals 1,200,000 pounds per square inch:

$$K=0.64 \sqrt{\frac{1,200,000}{1,000}}=22.2$$

Then

$$\frac{P}{A}=c \left[ 1 - \frac{1}{3} \left( \frac{L}{Kd} \right)^4 \right]$$

or

$$\frac{5,500}{A}=1,000 \left[ 1 - \frac{1}{3} \left( \frac{35}{22.2 \times 1.625} \right)^4 \right]$$

$$A=\frac{5,500}{705}=7.8 \text{ square inches}$$

Therefore, use a 2- by 6-inch member, which has the closest net area, 8.9 square inches.

If sheathing thickness is included in the least dimension, the value for  $d$  increases accordingly and more than likely a smaller member than a 2 by 6 will be required.

*Long columns.*—For columns with  $\frac{L}{d}$  ratios equal to  $K$  or greater the Euler formula with a reduction factor of 3 is used. This formula is as follows:

$$\frac{P}{A}=\frac{0.274E}{\left(\frac{L}{d}\right)^2} \quad (5)$$

Ordinarily the slenderness ratio  $\left(\frac{L}{d}\right)$  of a solid wood column should not exceed 50. In crate construction, when it does, with the combined thickness of 2-inch members and sheathing, the unsupported length must be decreased. This may mean spacing the struts closer together for upper frame members, or adding an intermediate longitudinal member in the side for diagonals.

An example in the use of the column formula for long columns is:

Assume  $P=3,000$  pounds;  $E=1,200,000$  pounds per square inch;  $L=80$  inches; and  $d=1\frac{5}{8}$  plus  $\frac{3}{4}=2.375$  inches (includes sheathing thickness).

The  $\frac{L}{d}$  ratio would then be  $\frac{80}{2.375}=33.7$ , which is within the limits of the formula for long columns. Then

$$\frac{P}{A}=\frac{0.274E}{\left(\frac{L}{d}\right)^2}$$

or

$$\frac{3,000}{A}=\frac{0.274 \times 1,200,000}{\left(\frac{80}{2.375}\right)^2}$$

or

$$A=\frac{3,000}{290}=10.3 \text{ square inches}$$

Thus, a 2- by 8-inch member with a net area of 12.2 square inches would be satisfactory.

While the thickness of the sheathing is considered in determining the  $\frac{L}{d}$  ratio, it should not be included in selecting the net area of the member. The sheathing is considered when determining the ability of the crate to support top loads and will be discussed later.

*Selection of sizes.*—The previously listed formulas based on the graphic method will determine the sizes of the members in the sides of a crate needed to meet stresses imposed by the weight of the crate and the contents. However, in crate construction it is practical to use struts that are all the same size. For example, if several struts require 2 by 4 areas and others 1 by 4, it is usual to use 2 by 4's for all struts. Likewise all diagonals should be the same size. Because of fabrication methods they should be the same thickness as the struts. The upper and lower frame members are in one piece, except in long crates, where the frame members are securely spliced. Consequently, these frame members should be of a uniform cross section for their entire length, with the greatest stress or size as the controlling factor for the entire length. In designing the lower frame members, 75 percent of the tension value of the skid is subtracted from the stress to be met, and the lower frame member designed to meet the remainder of the stress.

After the sizes of the frame members have been determined for the conditions outlined, they must be examined to determine their capacity for superimposed loads. These loads depend on the size of the crate. The wider the crate becomes, the greater the superimposed load might be. The width of the crate affects not only the design of the top and base, but, also the struts in the sides and ends. So all struts should be checked as columns to carry a possible superimposed load of from 200 to 400 pounds per square foot of crate top. Because of these superimposed loads, 1-inch-thick struts are usually limited to heights between 8 and 10 feet, except on very narrow crates where the superimposed loads could not become very great per strut. The same column formulas previously listed (2), (3), (4), and (5), should be used for these calculations.

In stacking sample crates of like size, stacking heights of from 25 to 60 feet were achieved before loads reached 200 pounds per square foot. It is reasonable to assume, however, that in extremely heavy crates sides and ends must often be designed to support as much as 400 pounds per square foot. Knowing the conditions to which the crate will be subjected, the crate designer can select the ton load in his calculations.

## DESIGNING THE CRATE BASE

The skid-type base for most crates, whether open or sheathed, consists of longitudinal skids with end headers and other cross members. These cross members may consist of load-bearing floorboards (to carry loads across to the skids), forklift headers, diagonals for racking resistance, and flooring of various types. The heavier members are bolted to the skids; lighter members and the flooring are then nailed to the skids to form a rigid unit suitable for mounting almost any type of item. Sill bases are made up of members placed on edge and framed to form a structural system. These bases are also considered in the design analysis.

### Skids

In designing a crate, it is assumed that a large part of the load imposed by the contents is carried by the side panels acting as trusses. Therefore, large skids are not necessary as load-carrying members because the sides act integrally with the skids in this function. While this assumption results in smaller size skids, it does not permit handling and moving a loaded base alone without the sides and ends fastened in place. If the base is to be moved with the item in place, the skids must carry the entire load when lifted by slings from the ends. The skids must then be computed as beams, which results in much larger sizes. The size of skids under these conditions depends on the location of the load with respect to the length of the skids and somewhat upon the kind of load. Some items are amply rigid to be lifted without much aid from the skids.

Flexure formulas for timber beams can be used to determine the size of skids required for a loaded base to be moved and handled without the sides in place. The size can be determined for either a uniformly distributed load or a concentrated load.

In designing a beam for flexure, the maximum bending moment may be computed from the following formulas:

$$M = \frac{Wl}{8} \text{ (for uniform load)} \quad (6)$$

or

$$M = \frac{Wl}{4} \text{ (for load concentrated at center of span)} \quad (7)$$

where  $M$  is the maximum bending moment,  $W$  is total load on beam in pounds, and  $l$  is length in feet. This results in a moment measured in foot-pounds that can be changed to inch-pounds by multiplying by 12.

The flexure formula is then used to compute the section modulus of the beam as follows:

$$\frac{M}{f} = S \quad (8)$$

where  $S$  is section modulus and  $f$  is safe extreme fiber stress in bending.

The crate designer should decide the value of  $f$ , which varies with species, moisture content, duration of load, and so forth, from 1,000 to 1,600 pounds per square inch or more. Methods of determining working stresses have been described (p. 10).

The section modulus,  $S$ , is equal to the moment of inertia,  $I$ , divided by  $c$  (distance of fiber farthest from neutral axis), or

$$S = \frac{I}{c}$$

For rectangular sections such as skids, load-bearing floor members, and joists:

$$\frac{I}{c} = \frac{bd^2}{6}$$

where  $b$  is total width of the beam and  $d$  is depth of the beam. The section modulus formula would then be

$$S = \frac{bd^2}{6} \quad (9)$$

From formulas (6) or (7), (8) and (9), the total width of the skids can be determined when they are designed as beams for handling the loaded base without aid from the side and end panels.

The following example illustrates the method of determining the size of skids when they are designed as beams:

At a skid length of 10 feet, a total uniformly distributed load of 5,000 pounds, and a working stress of 1,200 pounds per square inch,

$$M = \frac{Wl}{8} = \frac{5,000 \times 10}{8} = \frac{6,250 \text{ foot-pounds}}{75,000 \text{ inch-pounds}}$$

$$\frac{M}{f} = S \text{ or } \frac{75,000}{1,200} = 62.5 \text{ cubic inches}$$

$$S = \frac{I}{c} \text{ or } \frac{bd^2}{6} = 62.5$$

$$bd^2 = 375$$

Assuming the skids to be a nominal 6 inches deep, or 5½ inches effective depth,  $b = \frac{375}{d^2} = \frac{375}{30.3} = 12.4$ , or a total width of about 12½ inches. This total width may be divided into two or more skids, depending on the width of the base. The skids should be selected from standard timber

sizes. It is usual to select skid sizes that result in shapes no greater in depth than  $1\frac{1}{2}$  times the width. When skids are too deep, they may tip when the loaded base is pushed or moved.

The width,  $b$ , may be assumed and the depth is then solved in formula (9).

The flexure formulas are one of the accepted methods of determining, without a consideration for a minimum deflection, the size of a member acting as a beam in bending. In the majority of crate designs the deflection is not considered because strength is the main problem.

### Sills

A sill base is a framework of load-bearing members called side, end, and intermediate sills. The side sills are considered as lower frame members of the sides, similar to the skids in a skid base. When handling of the loaded sill base alone is considered, the side sills should be computed as beams and the flexure formulas used as described for skids. Unless this additional strength is included in the design, the loaded sill base should not be handled or moved without the side and end panels in place.

The intermediate sills act as load-bearing members for the item and transfer the load to the side sills. The sizes are determined by calculating them as beams with uniformly distributed or concentrated loads as described for the sills. The major difference is generally the shape of the sills, which are usually made up of 2-inch-thick material and are 8, 10, or 12 inches deep, depending on the load and span.

Included in the section on sheathed crates are tables listing the allowable loads for various spans of the sills. These tables usually serve the need of the designer. They include average-density lumber with those strength-reducing characteristics ordinarily allowed in load-bearing members. The allowable stress used was approximately 1,000 pounds per square inch. However, the use of formulas may be worthwhile for denser lumber with few strength-reducing factors. The size of the intermediate sills would then be determined as shown in the following example:

Where span equals 8 feet, the load of 8,000 pounds is to be carried by two sets of intermediate sills as a concentrated load, and a working stress of 1,400 pounds per square inch. Then

$$M = \frac{Wl}{4} = \frac{8,000 \times 8}{4} = \frac{16,000 \text{ foot-pounds}}{192,000 \text{ inch-pounds}}$$

$$\frac{M}{f} = S \text{ or } \frac{192,000}{1,400} = 137 \text{ cubic inches}$$

$$S = \frac{I}{c} = \frac{bd^2}{6} = 137$$

$$bd^2 = 822$$

Assume that two nominal 2-inch (actually 1.625) intermediate sills will be used at two locations for a total of four. Then the total width  $b=6.5$  inches and

$$d^2 = \frac{822}{6.5} = 126.5$$

$$d = 11.2 \text{ inches}$$

Use a total of four 2- by 12-inch intermediate sills.

### Floorboards

The floorboards of a skid base help to frame the base, serve as sheathing for it, and carry loads. When used only as sheathing or flooring the boards usually are 1-inch material, but may be plywood. Some crates are constructed with 2-inch-thick floorboards at each end of the base, which serve to prevent damage from forklift handling. Concentrated loads often require heavy floorboards that are fastened to the edge skids. Generally, those floorboards that carry loads are called load-bearing floorboards and should be designed so that the unsupported length is the clear distance between the edge skids.

Floorboards upon which the load rests are probably the most severely strained members of a crate because of the increased stresses caused by impact when a crate is handled roughly. Consequently, even though they are bolted or nailed to the skids, the load-bearing floorboards are computed as simple beams, which results in slightly larger members. This method of computing has been proven by evaluations of loaded crates of many weights and sizes at the Forest Products Laboratory. The floorboards were the most commonly broken members. However, it should be remembered that under normal conditions a beam can withstand a higher unit stress for a short time than it can for an extended period of time.

Heavy items packed in crates may or may not rest on a large area of the flooring. It is necessary to determine how much of the flooring actually carries the load, so that the load can be safely transferred to the truss side of the crate at the edge skids. This flooring, depending on how the load is mounted, may even be one or more large members. Safe loads for various thicknesses and spans have been computed (table 11).

Size of the load-bearing floorboards is calculated in the same manner as described for the skids and the intermediate sills. It is first necessary to solve for the bending moment,  $M$ , which depends on the type of loading expected. The bending moment for a concentrated load at midspan,  $M = \frac{Wl}{4}$ , is the most severe loading condition. A uniformly distributed load  $M = \frac{Wl}{8}$ , is considered

the least severe of the bending moments commonly used in the design of beams. A third bending moment formula,  $M = \frac{Wl}{6}$ , results in moment values midway between the concentrated and uniformly distributed loads.

TABLE 11.—Allowable load per inch of load-bearing floorboard width with woods of groups I and II<sup>1</sup>

Distance between outside skids	Allowable load when floorboard depth is—				
	¾ inch	1⅛ inches	2⅞ inches	3⅝ inches	5½ inches
<i>In.</i>	<i>Lb.</i>	<i>Lb.</i>	<i>Lb.</i>	<i>Lb.</i>	<i>Lb.</i>
12.....	47	220	574	1,095	2,520
18.....	32	147	382	731	1,678
24.....	24	110	287	548	1,260
30.....	19	88	229	438	1,008
36.....	16	73	192	365	841
42.....	14	63	164	315	720
48.....	12	55	144	274	630
54.....	11	49	127	243	560
60.....	9	44	115	219	504
66.....	9	40	104	199	458
72.....	8	37	96	182	420
78.....	7	34	88	168	388
84.....	7	31	82	156	360
90.....	6	29	77	146	336
96.....	6	27	72	137	315
102.....	6	26	67	129	296
108.....	5	24	64	122	280
114.....	5	23	60	115	265
120.....	5	22	57	110	252

<sup>1</sup> If woods of groups III or IV are used, these allowable loads may be increased by 20 percent.

## DESIGNING THE TOP

Two types of superimposed loads are carried by crates: (1) smaller crates or boxes that result in bending stresses in the top joists, and (2) other crates of equal size that place most of the load on sides and ends and very little on the top joists.

The first type is often referred to as loading without dunnage and the second type is with dunnage or like-on-like loading.

The increase in like-on-like methods of stacking large crates in storage has reduced the need for high load assignments for joists. Crate tops designed for loads of 50 pounds per square foot have proven satisfactory. The use of these lower design limits often results in a saving of 30 percent in material for top panels. Other load assumptions used in designing tops have been as much as 100 to 175 pounds per square foot. The choice of the limits should generally be controlled by transportation and storage conditions.

Joists are the structural members of the top panel and have several functions. They carry the

loads imposed by placing small crates and boxes on the top but not directly over the sides or ends. In this case, the joists act as beams to support the load and transfer it to the sides of the crate. Another important function of the joists is to resist pressures from such lifting devices as slings or grabhooks, which place crushing pressures on the sides near the top. Ordinarily joists resist the lifting pressures when spaced evenly along the crate length. However, it may be necessary to add extra joists to heavy crates or to include joists in very narrow crates that normally would not have them.

In computing the size of joists required, it is recognized that the top cross sheathing carries part of the load. In fact, in narrow crates with moderate top loads, the crosswise sheathing often is sufficient without joists. However, the sheathing must be full length and have a solid bearing on the side panels. The sizes of the joists are found with the various beam formulas described in the preceding section on base design.

An example of the design of a joist system for the top panel of a crate follows.

Assume that the crate top is uniformly loaded and will have nominal 1-inch sheathing placed across its width, all pieces of full length. Also assume that the width (span) of the crate is 8 feet, the design load is 100 pounds per square foot, the joists are placed 2 feet on center, and a safe unit stress is 1,000 pounds per square inch. First, the amount of load that can be assigned to the sheathing is found. Inasmuch as the joists will be placed 2 feet apart, the amount supported by a 24-inch width of sheathing can first be determined.

Because the size of the sheathing is known, the method of calculation is reversed from the usual procedure.

$$S = \frac{I = bd^2}{c = 6} = \frac{24 \times 0.75 \times 0.75}{6} = 2.25$$

$$\frac{M}{f} = S \text{ or } M = 1,000 \times 2.25 = 2,250$$

$$M = \frac{Wl}{8} \text{ or } W = \frac{2,250 \times 8}{8 \times 12} = 187 \text{ pounds}$$

The load assigned to the sheathing would be 187 pounds or about 12 pounds per square foot. This would reduce the total load assigned to one joist by 187 pounds, or 1,600-187=1,413 pounds.

Then solving for the joist size

$$M = \frac{Wl}{8} = \frac{1,413 \times 8 \times 12}{8} = 16,956 \text{ inch-pounds}$$

$$\frac{M}{f} = S = \frac{16,956}{1,000} = 17.0 \text{ cubic inches}$$

$$S = \frac{I}{c} \text{ or } \frac{bd^2}{6} = 17.0$$

$$bd^2 = 102 \text{ square inches}$$

If the thickness,  $b$ , of the joist is  $1\frac{1}{4}$  inches (1.625)

$$d^2 = \frac{102}{1.625} = 62.8$$

$d = 7.9$  inches (required depth of joist)

A 2 by 8 joist is just under this size (7.5); so a 2- by 10-inch joist must be used, spaced 24 inches on center.

Variations of spacing may be used to conserve materials. Inasmuch as a 2 by 8 joist is slightly under the required size, the designer might change the spacing of the joists so the 2 by 8 can be used. The use of a denser species with a higher working stress is another method of reducing the size of the joist.

Many open or partially sheathed crates have no joists. In these and in fully sheathed crates that do not have enough regular joists to resist grabhook pressure, it is necessary to use special joists. These joists should be placed at the center of balance of the loaded crate and their size determined by the width and weight of the crate. Very long crates are often handled by more than one pair of grabhooks, so more than one lifting joist may be needed.

These reinforcing joists can be calculated by use of the column formulas (2), (3), (4), and (5). For one set of grabhooks, the total weight of the crate and contents should be used for  $P$ . For two sets and two reinforcing joists, one-half the total weight should be used for  $P$ .

Further information on the top construction of sheathed crates, including joist sizes and spacings for tops of various widths, is in the following section.

## SHEATHED CRATES

Sheathed crates may be used for packaging items that require full protection by a closed container, for overseas or domestic shipment. They may be sheathed with lumber (fig. 14) or with plywood (fig. 15). For ease in describing their requirements and characteristics, sheathed crates are in three categories in this handbook: (1) the military type, for loads that do not exceed 30,000 pounds for either overseas or domestic shipment; (2) the limited-military type, for similar shipment of loads of not over 2,000 pounds; and (3) the light-duty type (fig. 16), for loads not over 1,000 pounds shipped by air anywhere or by surface transportation within the United States.

### MILITARY TYPE SHEATHED CRATES

Military type crates are intended for domestic and overseas shipment of loads not exceeding 30,000 pounds of all kinds of manufactured articles that require protection from the weather and mechanical damage. They are designed to withstand normal rough handling. Specifically, the tops are designed to carry loads of 50 pounds per square foot without dunnage. Sides of crates containing items that weigh not more than 10,000

pounds are designed to resist top loads of 200 pounds per square foot with dunnage. Sides of crates designed for loads over 10,000 pounds will carry top loads of 400 pounds per square foot with dunnage.

Member sizes are included in Appendix I for crates up to 48 feet long, 10 feet wide, and 12 feet high. Both lumber- and plywood-sheathed styles are included, as well as nailed (nondemountable) and bolted (demountable) assemblies.

### Base Construction

The first part of the crate to be fabricated is the base. Its size is usually determined by first measuring the overall length and width of the item to be crated. Add to these measurements the desired clearances (from 1 to 3 inches) and the thickness of the frame members of each end and each side. The total of these measurements is the size required for the base. Description and details of the sill base (fig. 17) are included, although the skid base (fig. 18) is most common.

*Skid base.*—The skid-type base consists of longitudinal skids that are assembled with such cross members as headers, load-bearing floorboards, diagonals, and plywood or lumber flooring.

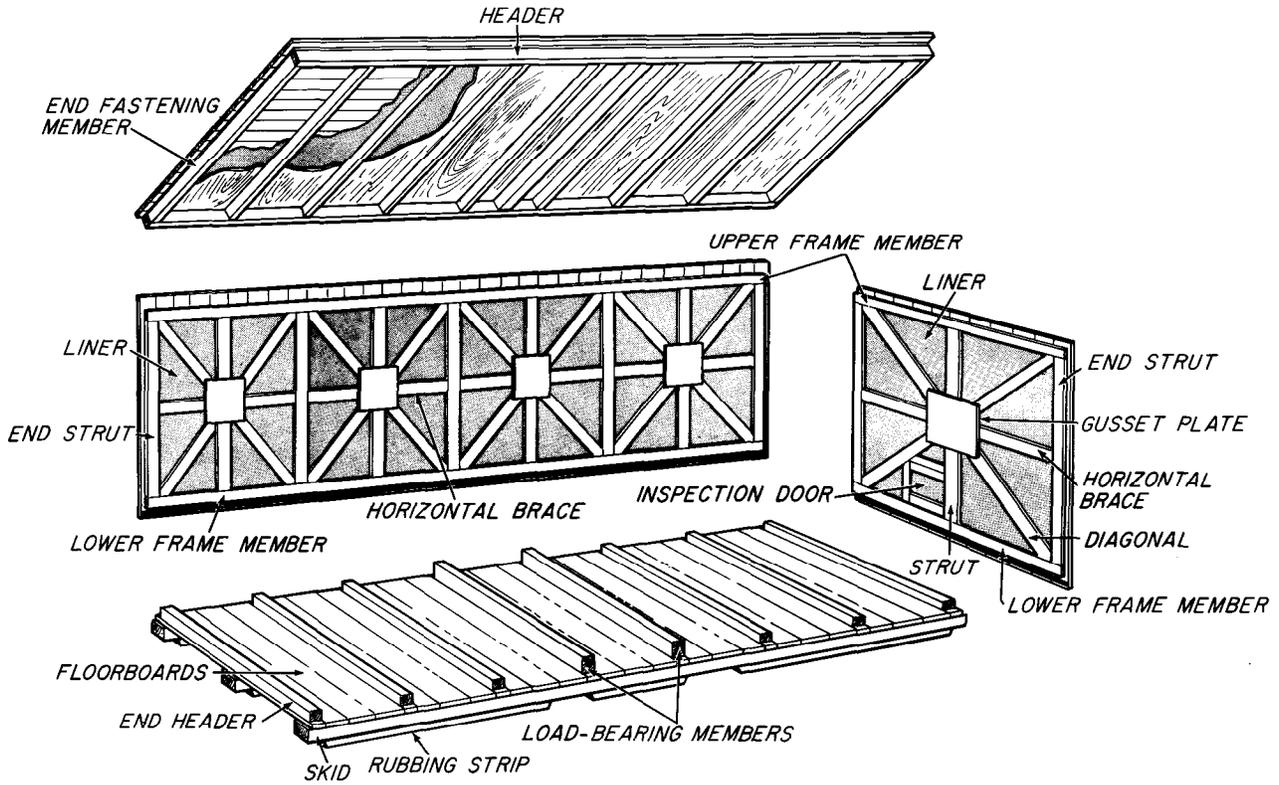

Figure 14.—Exploded view of a lumber-sheathed crate designed for assembly with lag screws.

M-119652

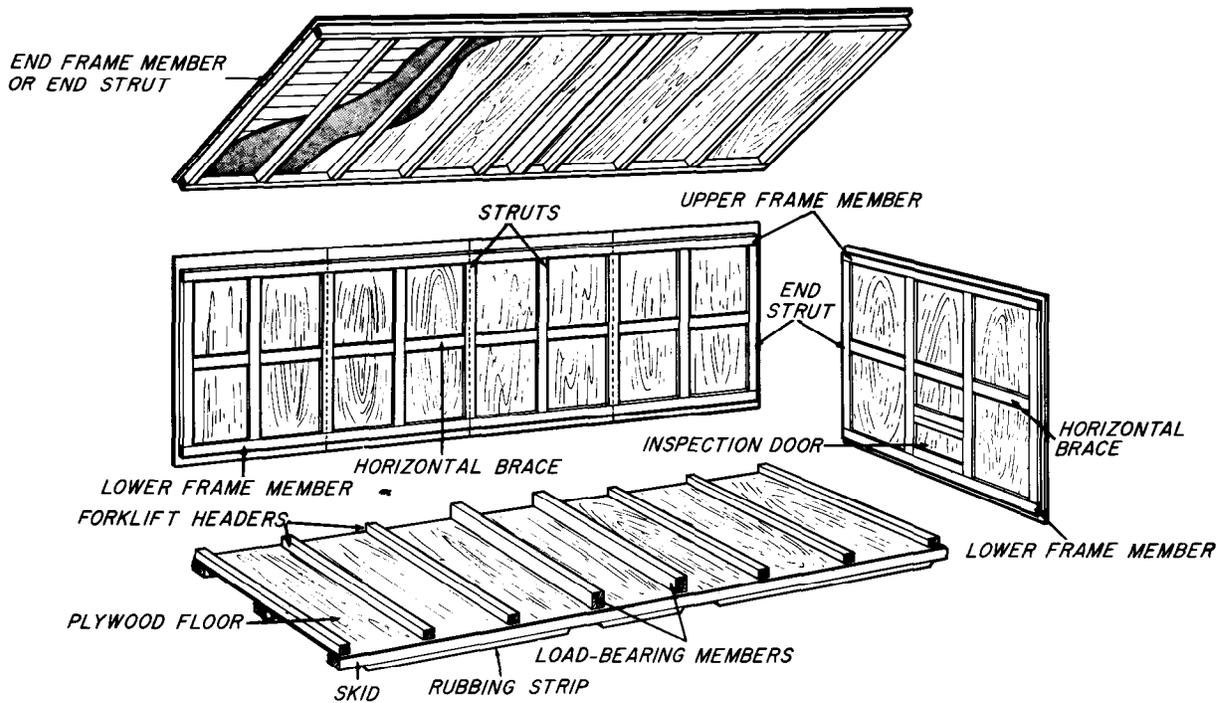
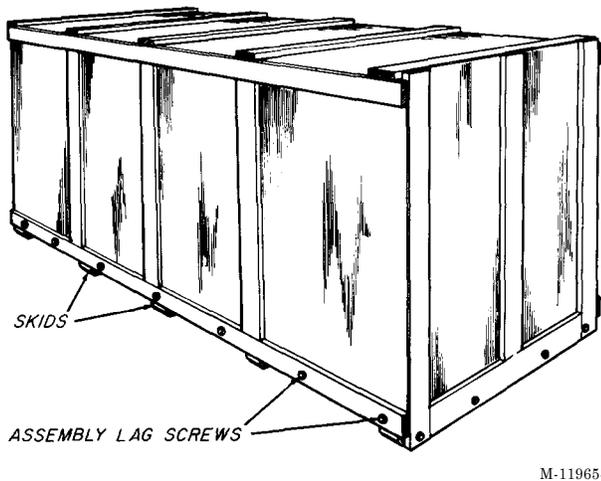

Figure 15.—Exploded view of a plywood-sheathed crate to be assembled with nails.

M-119653



M-119654

Figure 16.—Light-duty type sheathed crate of cleated-panel type.

The size of the skids required will depend on the size of the load and the length of the crate:

Maximum net load (pounds)	Maximum length of crate (feet)	Minimum size of skids (inches)
300	16	2 by 4 (flat)
1,000	12	2 by 4 (flat)
2,000	20	3 by 3
10,000	48	4 by 4
30,000	32	4 by 6 (on edge)

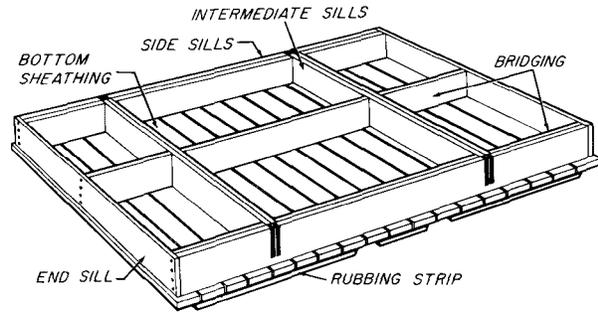

M-119658

Figure 17.—Sill-type base for crates.

When the width of the base is over 42 inches, an intermediate skid is added to aid in forklift handling from the sides of the crate. Four skids are needed when the crate width is over 7 feet.

Size of end headers and diameter of bolts depend on the skid size.

Skid size (inches)	Header size (inches)	Bolt diameter (inch)
2 by 4	2 by 4	3/8
3 by 3	3 by 3	3/8
3 by 4		
4 by 4	4 by 4	1/2
4 by 6		

In addition to headers at the ends of the crate, headers may also be bolted to the skids 20 and 40 inches from each end for forklift handling. Thus, the end and forklift headers serve to support

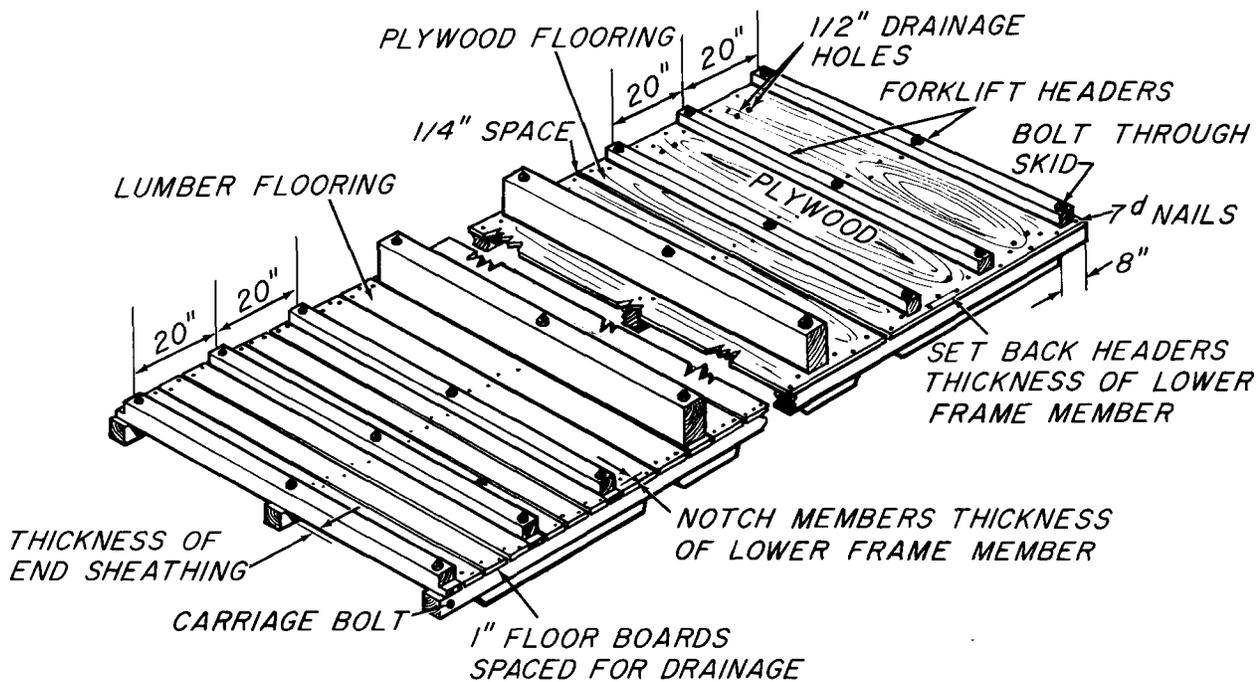

M-119670

Figure 18.—Typical skid-type base for sheathed crate, showing both lumber and plywood flooring.

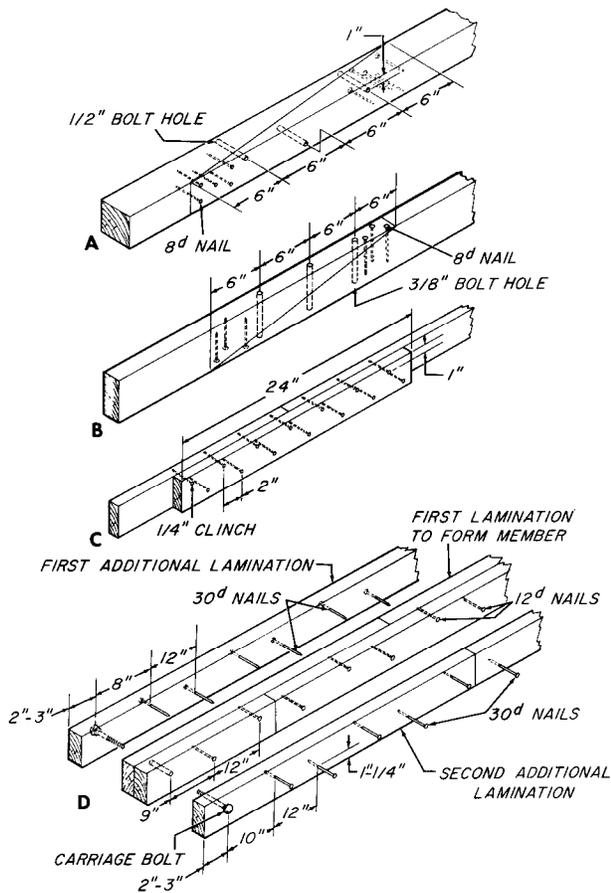

M-119671

Figure 19.—Splicing and laminating: A, Splice of 4- by 4-inch or 4- by 6-inch skid; B, splice of P-inch member; C, splice of 1-inch member; D, lamination of skid.

the crate on the forklift fingers and prevent damage.

The load-bearing floorboards are selected on the basis of the total load and the clear span between outside skids. The sizes may be selected from table 11.

Headers and heavy cross members over 2 inches thick are bolted to the skids with carriage or step bolts. At the ends of these members space is left for the lower frame members, which rest on the skid or flooring. The ends of the skids extend beyond the end headers a distance equal to the thickness of the end sheathing (fig. 18). It is good practice, in bases with lumber sheathing, to place the large cross members directly on the skid. With plywood sheathing, however, the large cross members are usually placed over the plywood (fig. 18).

Lumber sheathing is nailed to the skids with nailing patterns shown in figure 6. When the floor covering is plywood, it should be nailed to the skids with nailing patterns similar to those shown in figure 7.

It is necessary to provide for drainage in the floors of fully sheathed bases. Lumber sheathing boards can be spaced about one-eighth inch apart. In plywood sheathing, 1/2-inch holes should be drilled at the corners of each section where water might be trapped.

Rubbing strips are nailed to the bottoms of the skids to provide for side forklift or end sling handling. For small- or medium-size crates, a nominal 2- by 3-inch or 2- by 4-inch strip is used. For large, heavy crates it is well to use 3-inch-thick strips for large-diameter sling cables and for forklifts. End spacing for slings should be provided as shown in figure 18. The ends of the rubbing strips are full beveled at a 45° angle. Two-inch rubbing strips should be nailed to the skids with two rows of twelpenny nails staggered and spaced about 12 inches apart in each row. Longer nails are used for thicker rubbing strips.

In long crates, it is sometimes necessary to splice the skids or to use laminated members when single pieces of adequate length cannot be obtained. For greater strength, splices should not be located in the center third of the crate. The methods used for splicing and laminating are shown in figure 19.

*Sill base.*—The sill base is often used for items that project below their support points, such as rear axle assemblies or disassembled vehicles. The load should always be transferred to the side sills by intermediate sills with or without load-bearing headers, or by the article itself, so that the side panels can aid in strengthening the base (fig. 20). The sizes of the side and end sills for various size bases should conform to table 12. The sizes of intermediate sills and load-bearing headers should conform to table 13.

The base is fabricated by nailing the end sills into the side sills and side sills into intermediate sills. Bridging is used to prevent deep sills from tipping. Metal hangers at each end of intermediate sills are securely nailed to the side sills. These annealed steel straps carry most of the load to the side sills. The flooring is nominal 1-inch boards when spans are less than 30 inches between longitudinal members and 2-inch boards when spans are 30 inches or more. The flooring should be nailed to each crossing member with nailing patterns similar to those shown in figure 6. Rubbing strips are fastened under each longitudinal member (fig. 20).

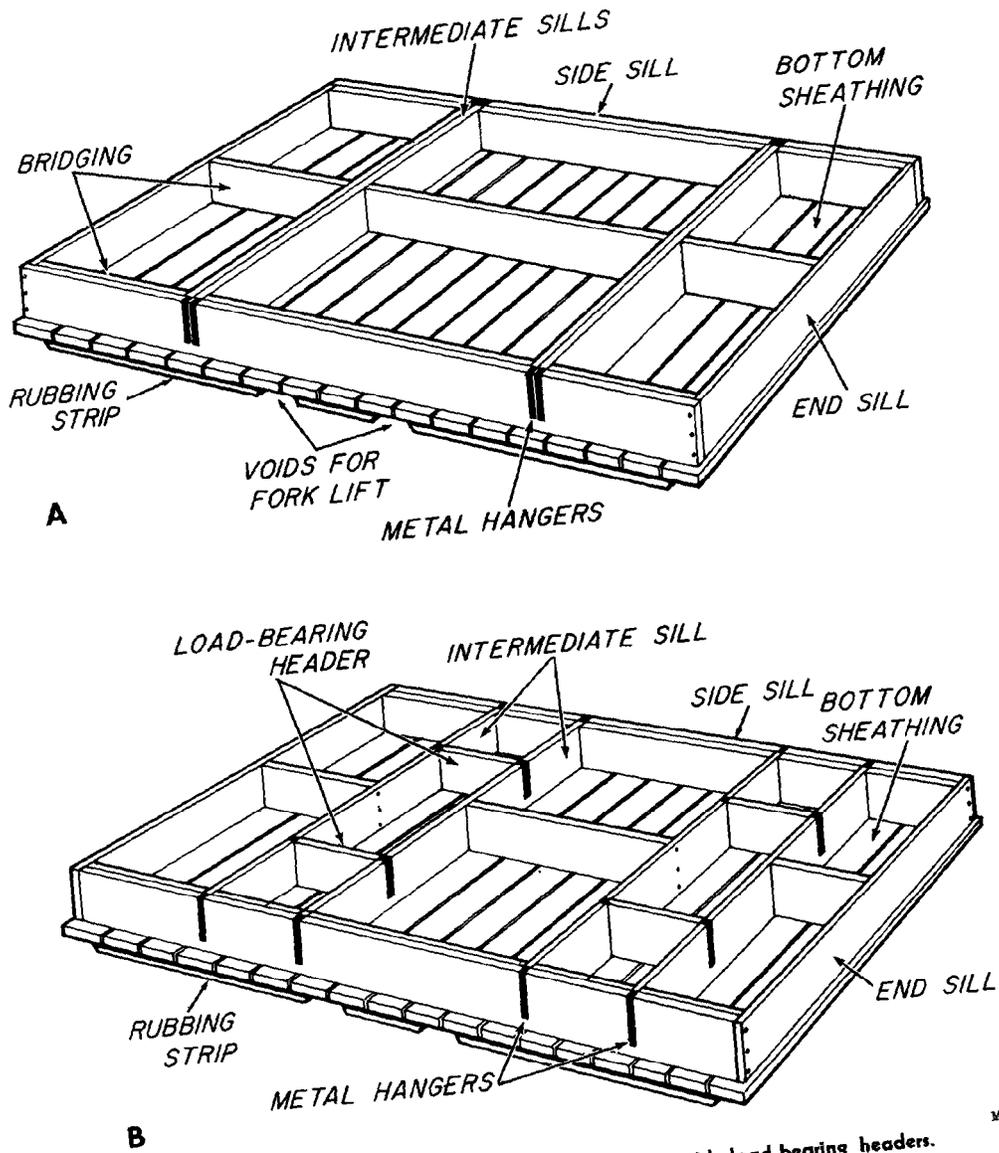

Figure 20.—Sill-type bases: A, with doubled sills; B, with load-bearing headers.

M-119672

TABLE 12.—Nominal size of side sills for crates over 3 feet high <sup>1</sup>

Gross weight of crate	Nominal size when length of crate in feet is—							
	4	8	12	16	20	24	28	32
<i>Lb.</i>	<i>In.</i>	<i>In.</i>	<i>In.</i>	<i>In.</i>	<i>In.</i>	<i>In.</i>	<i>In.</i>	<i>In.</i>
Up to 2,000	2 by 4	2 by 4	2 by 4	2 by 4	2 by 4	2 by 6	2 by 6	2 by 6
2,001 to 4,000	2 by 4	2 by 4	2 by 4	2 by 4	2 by 6	2 by 6	2 by 6	2 by 8
4,001 to 6,000	2 by 4	2 by 4	2 by 4	2 by 6	2 by 6	2 by 6	2 by 8	2 by 8
6,001 to 8,000	2 by 4	-----	2 by 6	2 by 6	2 by 6	2 by 8	2 by 8	2 by 8
8,001 to 10,000	2 by 4	-----	2 by 6	2 by 6	2 by 8	2 by 8	2 by 8	2 by 10
10,001 to 12,000	2 by 4	-----	2 by 6	2 by 8	2 by 8	2 by 8	2 by 10	2 by 10
12,001 to 14,000	2 by 4	-----	2 by 8	2 by 8	2 by 8	2 by 10	2 by 10	2 by 10
14,001 to 16,000	2 by 4	-----	2 by 8	2 by 8	2 by 10	2 by 10	2 by 10	2 2 by 8
16,001 to 18,000	2 by 4	-----	2 by 8	2 by 10	2 by 10	2 by 10	2 2 by 8	2 2 by 8
18,001 to 20,000	2 by 4	-----	2 by 10	2 by 10	2 by 10	2 2 by 8	2 2 by 8	2 2 by 8

<sup>1</sup> For heights of 3 feet or under, increase 2 by 4 sizes to 2 by 6; 2 by 6 sizes to 2 by 8; and 2 by 8 sizes to 2 by 10.

TABLE 13.—Allowable load for intermediate sills, in pounds per inch of sill width, for woods of groups I and II <sup>1</sup>

Length of sill	Allowable load when sill depth is—						
	1 1/2 inches	2 inches	3 inches	5 inches	7 1/2 inches	9 inches	11 1/2 inches
<i>Ft.</i>	<i>Lb.</i>	<i>Lb.</i>	<i>Lb.</i>	<i>Lb.</i>	<i>Lb.</i>	<i>Lb.</i>	<i>Lb.</i>
4	55	144	274	659	1,172	1,880	2,755
5	44	115	219	527	937	1,504	2,204
6	37	96	183	440	781	1,254	1,837
7	31	82	157	377	670	1,074	1,574
8	28	72	137	330	586	940	1,378
9	24	64	122	293	521	836	1,224
10	22	57	110	264	469	752	1,102

<sup>1</sup> If woods of groups III or IV are used, these allowable loads may be increased by 20 percent.

### Side Construction

The construction of sides for lumber- and plywood-sheathed crates (fig. 21) varies in the use of diagonals and usually in the spacing of the struts as well as in the type of sheathing. Usually both types have the same size frame-members and struts. The plywood-sheathed crate does not require diagonals or the paper liner that is ordinarily required for the lumber-sheathed crate. The height of the side must include the heights of the item, the base, and the top framing and top joists, plus top clearance.

The arrangement of the frame members for lumber-sheathed crates is usually based on the height of the crate and should conform to figures 22 and 23.

The sizes of the upper and lower frame members, struts, and diagonals are based on the loads to be carried. Member sizes for crates containing net loads up to 30,000 pounds are listed in Appendix I.

The end struts of the side panels receive nails or lag screws in assembly and should be at least a nominal 2 inches thick. Minimum end strut sizes depend on the load and whether assembly is with lag screws or nails:

Net load (pounds)	End strut size	
	Lag screw assembly (inches)	Nail assembly (inches)
1,000 or under	2 by 4	2 by 4
Over 1,000 but under 5,000	3 by 3	2 by 4
5,000 or over	4 by 4	2 by 4

The lumber sheathing for sides and ends should be of nominal 1-inch material of square edge or tongue-and-groove pattern. However, for net loads less than 300 pounds, 5/8-inch sheathing may be used.

In most types of sheathed crates, the sides are made to support the top panel, which is designed to carry top loads. In wide crates that carry heavy top loads, the top framing is a system of joists. The ends of the joists or the fastening members are supported by the upper frame members of the sides, which are at least 2 inches thick, or by an extra strut placed under each joist and fastened to the sides. Open crates, usually not designed to carry heavy top loads, do not need joists.

For sheathed crates assembled with nails, the side sheathing usually has sufficient thickness to develop the full lateral resistance of the nails along the skids. However, for heavy crates that require lag screws, the sheathing, especially plywood, requires some reinforcing. This may be done by adding a 1-inch fastening member or a lag screw steel reinforcing strap to the bottom of

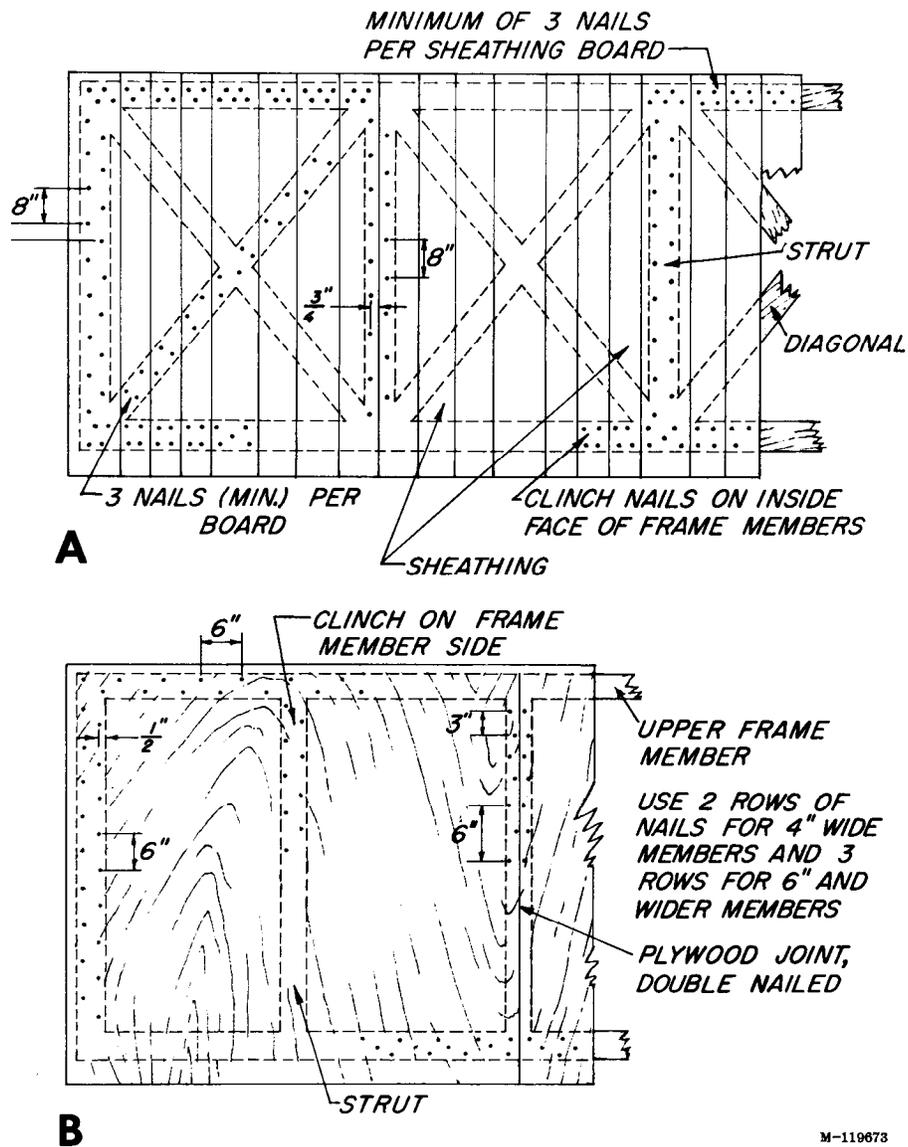

Figure 21.—Fabrication of sides for sheathed crates: A, Lumber-sheathed side, B, plywood-sheathed side.

the side. The strap is nailed to the fastening area of the side, and holes are drilled in the strap for the lag screws (fig. 11).

*Lumber-sheathed sides.*—The sides are divided into panels of even widths by the vertical struts. The spacing of these struts is such that the diagonals between form an angle as near 45° as possible. High crates may have two or three rows of panels, divided by the horizontal braces (fig. 22).

The horizontal and vertical members are positioned with the diagonals between (fig. 21, A). Corrugated fasteners or staples are often used to

hold the frame members together while the sheathing is nailed in place. A waterproof paper is usually placed between square-edged sheathing and frame members. Sheathing is nailed to the frame members as shown in figure 21, A with patterns as in figure 6. The placement and clinching of nails should follow the general rules (p. 17). The sheathing projects beyond the edge struts a distance equal to the thickness of the edge struts of the end. The projection of the sheathing below the lower frame member should equal the depth of (1) the skid, (2) the skid and flooring, or (3) the side sills, in a sill-type crate. The pro-

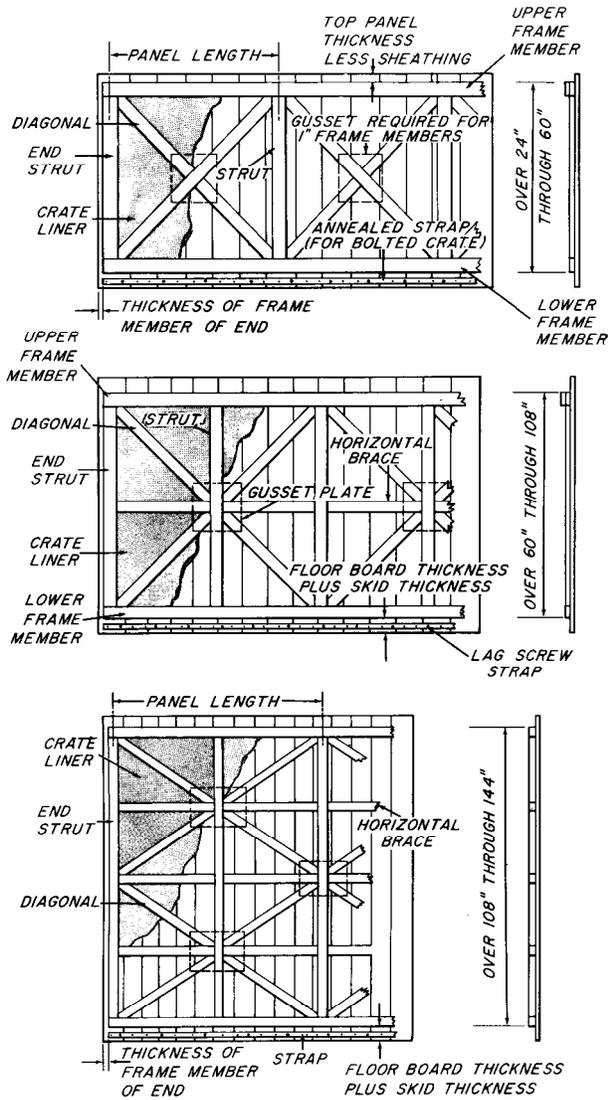

M-119691

Figure 22.—Crate sides of three heights with lumber panels.

jection of the sheathing at the top is equal to the thickness of the top frame members or the depth of the joists.

*Plywood-sheathed sides.*—The details in the construction of plywood-sheathed sides (fig. 21, B) and lumber-sheathed sides are much the same. With plywood the need for diagonals and waterproof paper is eliminated, which usually lowers the labor costs. Spacing the struts about 24 inches apart makes it unnecessary to rip the width of the plywood sheets. Odd-width panels may be located at each end of the side or at the center. Joints of the plywood are always made over the center of a frame member. The projections meet the same requirements as in lumber-sheathed sides. The

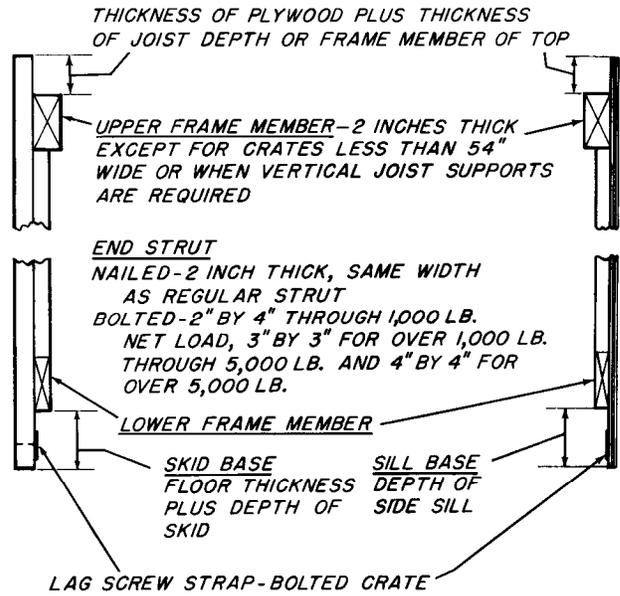

M-119692

Figure 93.—Frame member arrangement of crate sides of both lumber- and plywood-sheathed side panels.

placement and nailing of the members should follow figures 7 and 21. The general nailing rules (p. 17) should be followed. Horizontal braces to reduce the effect of strut length are added according to crate height; the type of panels should conform to figures 23 and 24.

Sizes of members and other details should be the same as for lumber-sheathed sides. Member sizes are listed in Appendix I.

Plywood sheathing for sides and ends should be 1/4 inch thick for net loads less than 300 pounds, 3/8 inch thick for net loads not exceeding 10,000 pounds, and 1/2 inch thick for net loads over 10,000 pounds.

### End Construction

The design for the ends of both lumber- and plywood-sheathed crates is much the same as for their sides (fig. 25). End panels are designed to rest on the end extension of the skids or on the end sills of sill-type bases. The bottom projection of the sheathing in the ends of sheathed crates will then correspond with the depth of skids or sills (plus sheathing thickness when sheathing is used under a header). The top projection corresponds to that of the sides or is equal to the combined thickness of the framing members. The sheathing at each side edge of the panel should extend beyond the edge strut for the thickness of the side sheathing. Spacing of struts, diagonal location, size of members, placement of reinforcing strap, and fabrication nailing are as outlined for the side panels.

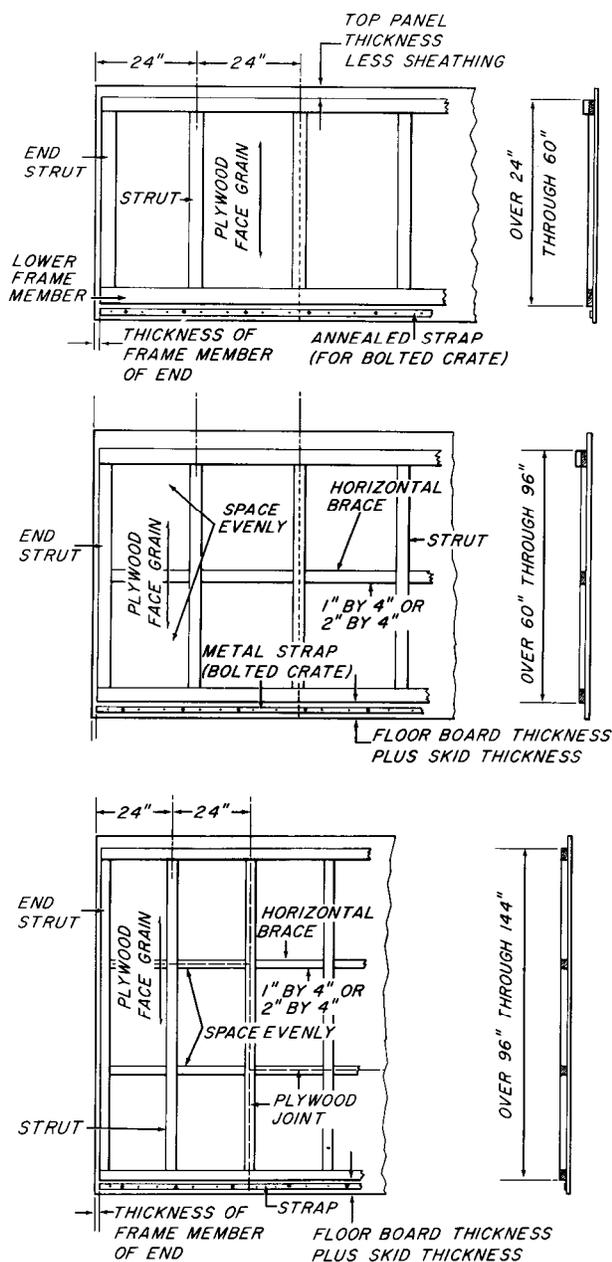

M-119693

Figure 24.—Side panels for plywood-sheathed crates of three heights.

Sheathed crates require ventilation to prevent moisture from accumulating and damaging the packaged item. To insure air movement, ventilators can best be located near the top in the end panels, and, in long crates, also in the side panels. Because of the tight construction of a plywood-sheathed crate, more ventilating area is required than in a lumber-sheathed crate. Tests have indicated that a lumber-sheathed crate should

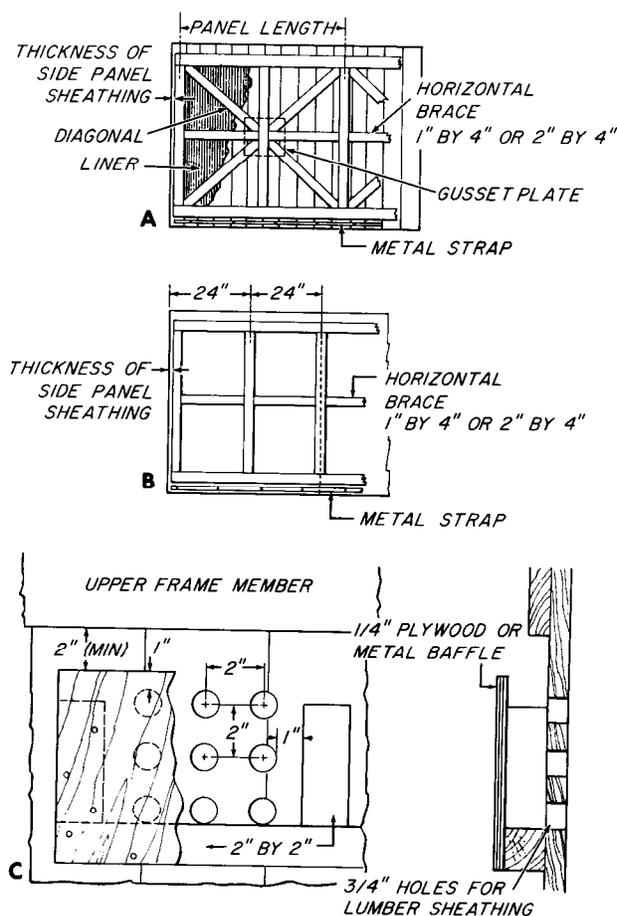

M-119675

Figure 25.—Ends for sheathed crates: A, Lumber sheathed, B, plywood sheathed, C, ventilation for ends of lumber-sheathed crates.

have in each end panel at least one ventilation hole three-fourths inch in diameter for each 45 cubic feet of crate volume. Details of vents and baffling for a lumber-sheathed crate are shown in figure 25, C.

Plywood crates require in each end at least 1 square inch of ventilating area for each 15 cubic feet of crate volume. The vent for a plywood-sheathed crate should be a horizontal slot with screening and a baffle. Additional cross members reinforce the sheathing around large vents.

*Lumber-sheathed ends.*—End panels are constructed as shown in figure 26. Frame members are the same size as those listed in Appendix I for the sides. For narrow ends, not over 30 inches wide, single diagonals may be used in place of crossed diagonals.

*Plywood-sheathed ends.*—The end panels of plywood-sheathed crates are constructed as shown in figure 27. Frame members are the same size as shown in Appendix I for the sides.

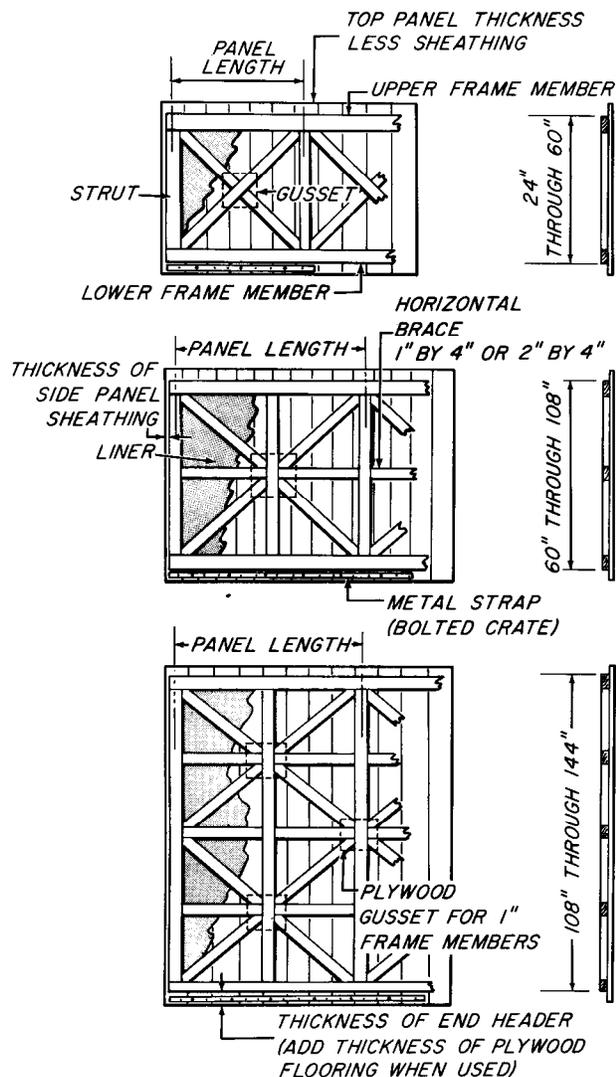

Figure 26.—End panels for lumber-sheathed crates of three heights.

### Top Construction

The tops of sheathed crates are ordinarily designed to carry other crates or boxes during shipping and storage. These top loads may vary from 50 to 175 pounds per square foot. Joists are fastened to the top during fabrication or to supports of the sides during assembly. The top without the joists consists of light (nominal 1-inch) frame members and sheathing similar to the side. Spacing of the top struts is usually the same as in the sides.

Because crates are exposed to variable weather conditions, the tops are ordinarily designed to be waterproof. Lumber-sheathed crates may be wa-

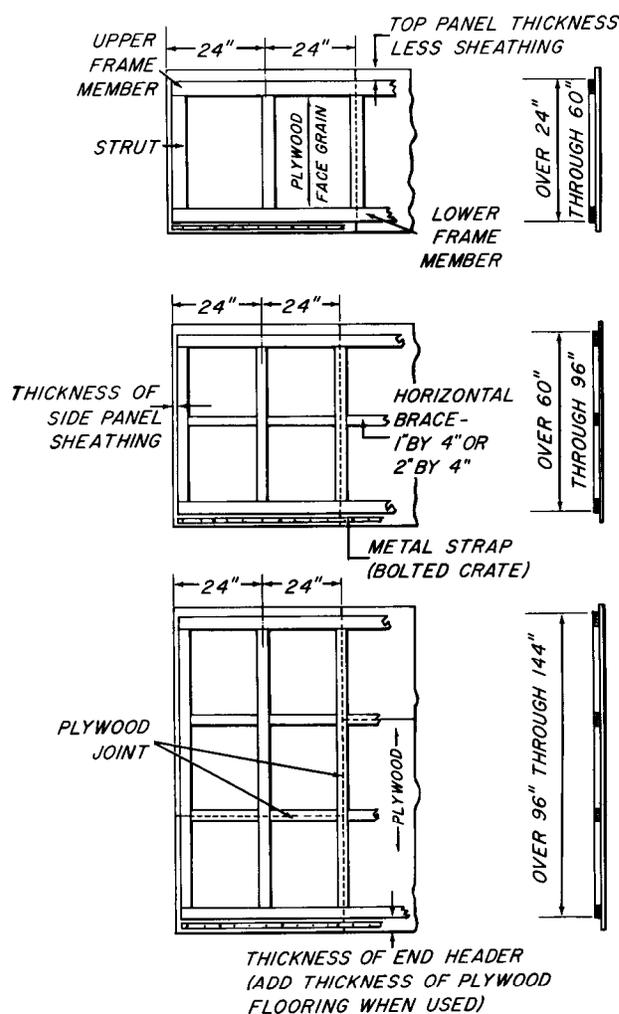

Figure 27.—End panels for plywood-sheathed crates of three heights

terproofed with a heavy asphalt-impregnated paper placed over the top and top edges after assembly, but often this paper is damaged during shipment. A better top is the double-sheathed top, described below. In a plywood-sheathed crate, where the plywood is fastened to each member, water resistance can be provided by a bead of calking compound made along each plywood joint after nailing. A 4-inch-wide strip of waterproof paper under each joint also prevents water entry.

To minimize water entry, top sheathing extends beyond the side and end sheathing. Placement of members and nailing should follow figure 28 and the methods described for the sides and ends. When joists must be fastened to the top by nailing through the plywood and the 1-inch frame members into the 2-inch edges, use tenpenny or twelpenny nails spaced about 10 inches apart.

M-119694

M-119695

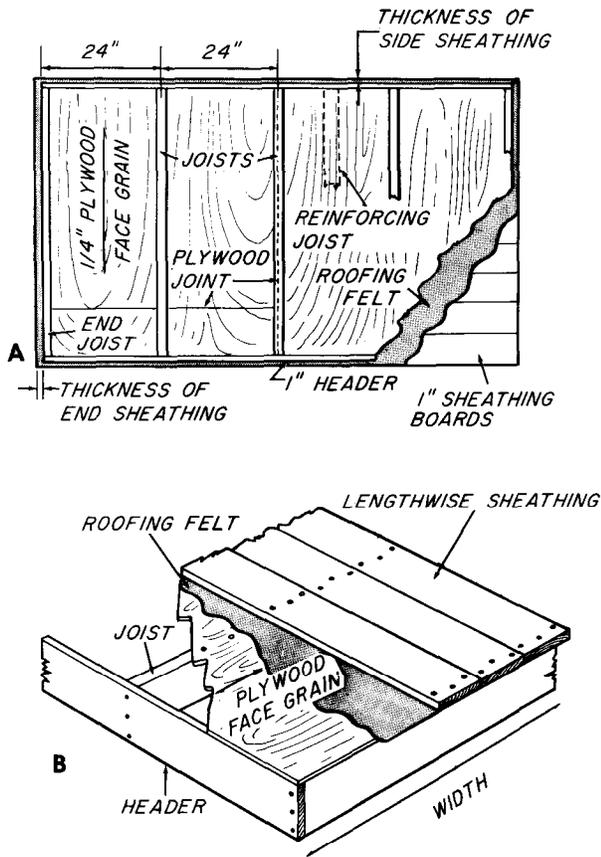

M-119677

Figure 28.—Typical top for sheathed crate: A, Inside view; B, fabrication.

**Double-sheathed tops.**—Double-sheathed tops consist of a supporting framework of joists and headers, a plywood covering to add rigidity, a roofing paper for waterproofing, and a lumber sheathing for mechanical protection (fig. 28).

Since tops are designed for loads of 50 pounds per square foot, joist sizes increase as the width of the top increases. Figures 29, 30, and 31 show the details for tops of various widths. Crates with tops up to 54 inches wide require no joists. Those over 54 through 60 inches wide use end joists that are 2 by 4 inches, laid flat. Other joists are 2 by 6 inches spaced 24 inches on center.

For crates over 60 through 120 inches wide, joists are placed on edge, spaced 24 inches on center, and vary by span:

Span (inches)	Joist size (inches)
60 to 66	2 by 4
66 to 78	2 by 4 plus 1 by 4, or a 3 by 4
78 to 90	Two 2 by 4's, or a 4 by 4
90 to 102	2 by 6
102 to 120	2 by 6 plus 1 by 6, or a 3 by 6

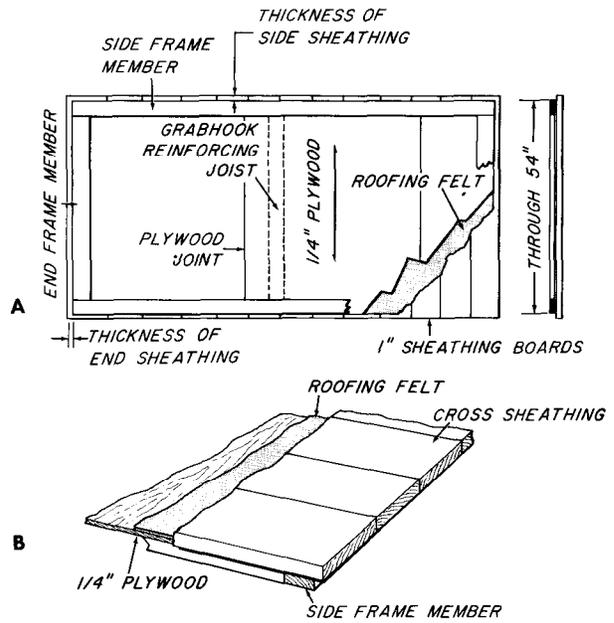

M-119696

Figure 29.—Typical top for sheathed crates through 54 inches wide: A, Inside view; B, fabrication.

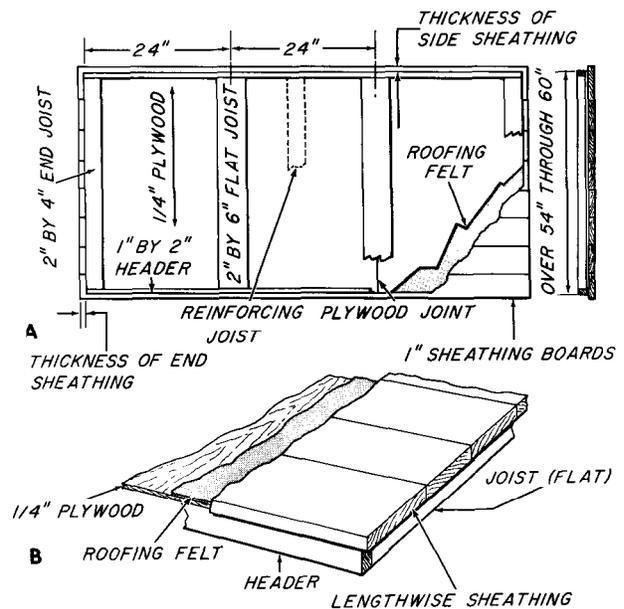

M-119697

Figure 30.—Typical top for sheathed crates over 54 through 60 inches wide: A, Inside view; B, fabrication.

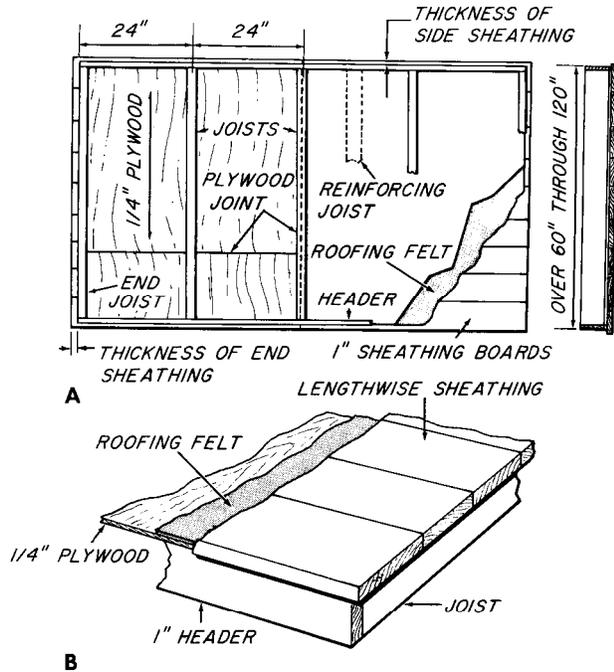

M-119698

Figure 31.—Typical top for sheathed crates over 60 through 120 inches wide: A, Inside view; B, fabrication.

When no joists are used in the top or when a joist does not coincide with the center of balance, a grabhook reinforcing joist should be located at the center of balance. The size should be selected as follows:

Size of single reinforcing joist (inches)	Gross loads not exceeding (pounds)	Length of joist not exceeding (inches)
2 by 4	1,000	72
2 by 4	2,000	60
2 by 4	3,000	48
2 by 4	5,000	36
4 by 4	10,000	96
4 by 4	15,000	72
4 by 4	22,000	60

When the gross load exceeds 22,000 pounds, or the width exceeds 96 inches for any loads over 10,000 pounds, two 4- by 4-inch joists should be placed 2 to 3 feet on each side of the center of balance, for handling with two sets of grabhooks.

**Plywood-sheathed tops.**—Tops may also be constructed entirely of plywood on 1- by 4-inch frame members. Frame members are spaced 24 inches on center. The tops are fabricated with clinched nails, as are the side and end panels of plywood-sheathed crates. Use 3/8-inch plywood for loads not exceeding 10,000 pounds and 1/2-inch plywood for loads over 10,000 pounds. The joist system, consisting of joists and headers, should conform to those in figures 29, 30, and 31, except that tops

without joists should be limited to 14 inches in width. Tops over 14 through 60 inches wide should have 2- by 4-inch joists.

### Assembly

Crates are most commonly assembled by nails (nondemountable) or by lag screws (demountable). A combination assembly includes nailing the sides, ends, and top together to form a cap, which is fastened to the base with lag screws. Most articles shipped in crates are anchored to the base. This method permits removing the base lag screws and lifting the cap for easy removal of the item, rather than disassembling the crate.

There is little or no basic difference in the assembly of a lumber- and a plywood-sheathed crate. Both require that the receiving members for lag screws be at least 2 inches thick. Lag screws and nails are usually about one-half inch longer for lumber-sheathed crates than for plywood-sheathed crates and their spacing may vary between the two types of crates.

**Fastening sides to base.**—In nailing the sides of the crate to the skids or sills, the number of nails required is based on the gross weight of the crate and contents. Table 14 lists the number of nails required for each 1,000 pounds of load. Half of the nails required should be spaced evenly along each side (fig. 32), no more than 3 inches apart. A skid 2 inches deep requires one row of nails; a skid or sill 4 inches deep, two rows; and a skid or sill over 4 inches deep, three rows.

The lag screws required for fastening sides to the base in skid-type crates are listed in table 15. The screw sizes are usually based on the thickness or depth of the skids. For 2-inch skids, use lag screws 5/16 inch in diameter; 3- or 4-inch skids, 3/8- or 1/2-inch; and for 6-inch or larger skids, 5/8-inch or larger. Half of the required number should be spaced evenly along each side of the base. Maximum spacings are:

Lag screw size (inches)	Spacing (inches)
5/16 by 3	12
3/8 by 3	16
1/2 by 4	20
5/8 by 4	20

The minimum length is usually based on diameter. The minimum distance each lag screw should penetrate into the receiving member is:

Lag screw diameter (inch)	Penetration (inches)
5/16	2
3/8	2
1/2	2 1/2
5/8	3
3/4	3 1/2

The recommended minimum length of lag screws equals the thickness of the side plus the penetration distance. However, lag screws may be as long as the total thickness of the members

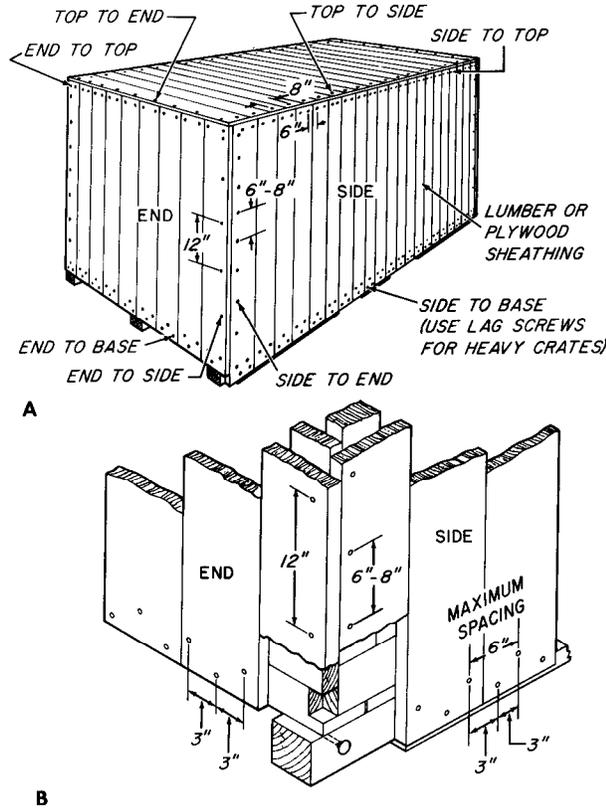

M-119679

Figure 32.—Nail assembly of sheathed crate: A, Lumber- or plywood-sheathed crate; B, corner detail.

being fastened. The number required is found by rule 5, p. 20.

Plywood- and lumber-sheathed sides for heavy crates require a 1-inch fastening member or a lag screw steel reinforcing strap nailed along the fastening area to reinforce the sheathing.

*Fastening ends to base.*—The end panels should be fastened to the end headers of skid bases or to the end sills with nails spaced no more than 3 inches apart (fig. 32). The nails should be placed

TABLE 15.—Minimum number<sup>1</sup> of lag screws required to assemble sides to base of sheathed crates using lag screw reinforcing strap (skids of group II, III, or IV woods)

Weight of crate and contents (pounds)	5/16- by 3- inch lag screws (for flat skids 2 by 4 inches)	3/8- by 3- inch lag screws (for skids 3 by 3 or 3 by 4 inches)	1/2- by 4- inch lag screws (for skids 4 by 4 inches)	5/8- by 4- inch lag screws (for skids 4 by 6 inches or heavier)
2,000	12	6	6	6
3,000	16	10	6	6
4,000	20	14	8	6
6,000	32	20	12	8
8,000		24	16	10
10,000			18	12
12,000			22	14
14,000			26	16
16,000			30	18
18,000			32	22
20,000			36	24
24,000				28
28,000				32
32,000				36
36,000				42
40,000				46

<sup>1</sup> Use one-half the total on each side. Minimum number is 3 per side and 2 per end.

in two or more rows when the depth of the end member is over 2 inches. Nail types and details are outlined under the nailing rules, p. 17.

Demountable skid-type bases may be assembled with lag screws or similar fasteners. Military type crates require reinforced sheathing as described above in sides-to-base fastenings. Lag screw lengths and sizes are the same as used in fastening sides to base. Spacing should follow the pattern shown in figure 33.

*Fastening ends and sides together.*—The members are usually arranged so that the sheathing of the side can be nailed to the edge strut of the end. The end can then be fastened to the side by nailing through the sheathing and edge strut into the edge strut of the side (fig. 32). This double

TABLE 14.—Minimum number<sup>1</sup> of nails, per thousand pounds of gross load, required to fasten sides to base of a sheathed crate

Skids of wood group	Sinkers or cooler nails			Corker nails			Common nails		
	Seven-penny	Eightpenny and ninepenny	Ten-penny	Seven-penny	Eightpenny and ninepenny	Ten-penny	Seven-penny	Eightpenny and ninepenny	Ten-penny
II	23	19	18	24	17	15	19	15	13
III	26	21	19	26	19	16	21	17	14
IV	19	16	14	19	14	12	16	13	10

<sup>1</sup> For each side use one-half of total required.

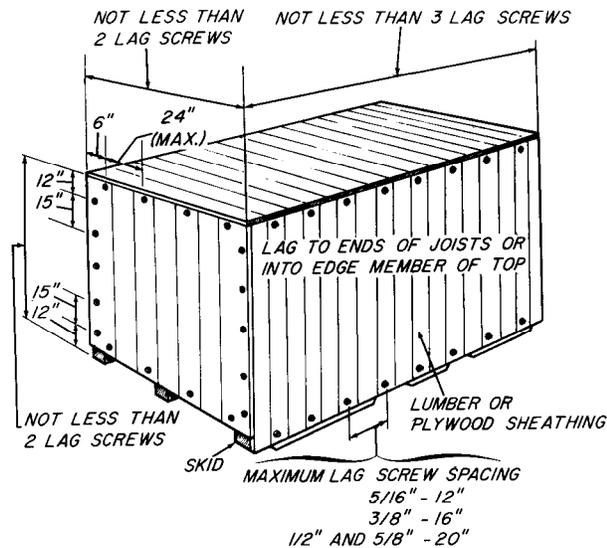

M-119680

Figure 33.—Lag screw assembly of military type sheathed crates.

nailing results in a strong corner because at least one set of nails is always in lateral resistance. The size and spacing of nails should follow figure 32 and the general nailing rules.

In demountable crates, the lag screws are located in the end panels. They pass through the sheathing and edge struts of the ends and penetrate the center of the edge struts of the sides. Lag screws used in the edge of 2-inch members should be  $\frac{5}{16}$  inch in diameter. In struts thicker than 2 inches use  $\frac{3}{8}$ -inch lag screws. Spacing is shown in figure 33. Lead holes and other details should follow the general rules for lag screws, p. 20.

*Fastening top to sides and ends.*—Because of the variations in top designs, many different fastening methods are necessary. However, the principles of fastening the top to the side and end panels are generally the same. Two methods are commonly used: (1) nailing through the sheathing of one panel into the edge of a frame member of the other panel, and (2) nailing or driving lag screws through the sheathing and frame member of one panel into the frame member of the other. If this double or cross fastening can be used to fasten the top to sides and ends, as in nailing the side and end panels together, it will result in a joint that is resistant to high withdrawal stresses.

Tops made of light framework and sheathing fastened to a series of top joists are usually nailed to the side and end panels (fig. 32). Twelve-penny nails are spaced 4 to 5 inches apart and staggered when the top is lumber sheathed. Ten-penny nails are used in plywood sheathing. These nails pass through both the sheathing and the 1-inch frame of the top and into the 2-inch upper member of the side or end.

Some tops may be constructed so that the sides and ends must be fastened with nails through their sheathing into the edge members of the top. The sides are also nailed through their sheathing into the ends of each joist.

The design of most demountable crates requires that the lag screws be placed in the side and end panels. Lag screws are not placed in the top panel because their heads would snag other crates or boxes piled on top. As shown in figure 33, the lag screws should be spaced about 20 to 24 inches apart and so placed that they penetrate the sheathing and upper frame members of sides or ends and enter the fastening members of the top. A lag screw  $\frac{5}{16}$  inch in diameter may be used in the edge of a 2-inch fastening member, a  $\frac{3}{8}$ -inch lag screw in larger fastening members. The length of these lag screws should be based either on the sum of all members or on the minimum penetration plus the side or end thickness.

## LIMITED-MILITARY SHEATHED CRATES

Plywood-sheathed crates of the limited-military type are intended for use in the domestic or export shipment of bulky items of not over 2,000 pounds. They are designed to be economical and to resist moderate stacking loads, average handling conditions, and light top loads (the weight of a man at or near the center of the span for about each 3 feet of crate length).

Limits of outside dimensions are 20 feet long, 12 feet wide, and 12 feet high. The crates are semidemountable: the top, sides, and ends are nailed together and this unit is fastened to the base with lag screws.

### Base

The base consists of cross skids and stringers nailed together and covered with plywood when necessary. The size of members and their location and placement are shown in figure 34. When load-bearing floorboards are required because of concentrated loads, the sizes should be selected from table 11, p. 31.

### Sides

Sides are made with 1-by 6-inch lower frame members and 1-by 4-inch struts. The upper frame members are arranged as shown in figure 35. Plywood is three-eighths inch thick, with joints made at the centers of struts or joint cleats. Joints may be made at ends of plywood panels when crates are more than 8 feet high. Ventilation is provided as shown.

### Ends

Ends are similar to the sides, but do not require joist spacers and ventilation (fig. 36). Member sizes and arrangements are the same as in the sides.

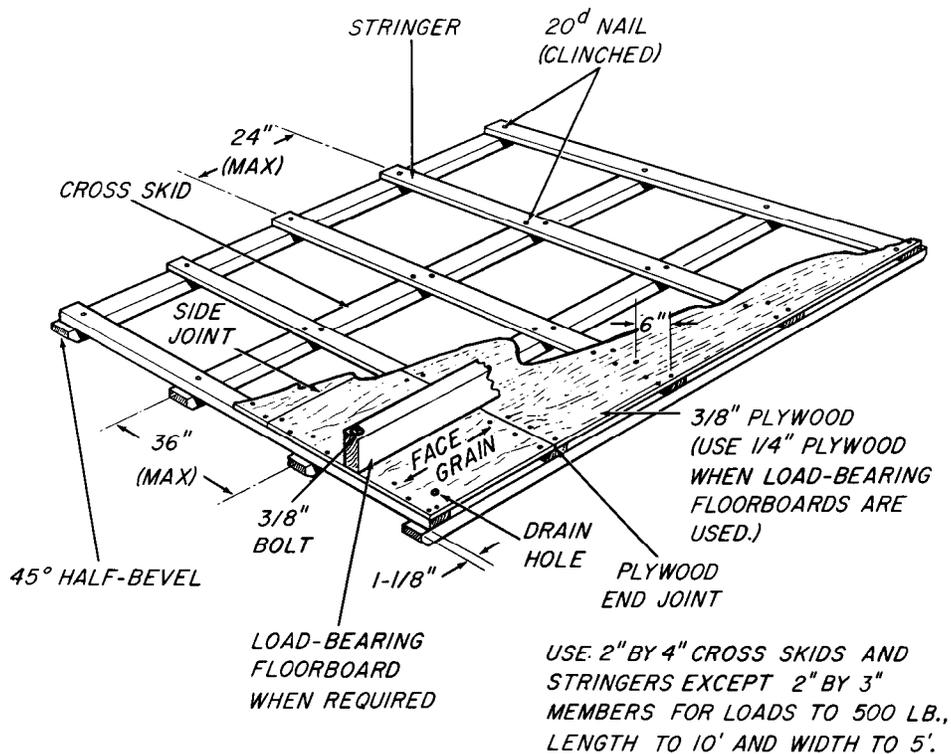

Figure 34.—Base for limited-military type sheathed crate.

M-119699

### Top

The three kinds of tops for this type of crate are based on the crate width (fig. 37). For widths that do not exceed 60 inches, the top consists of 1- by 4-inch cross struts spaced 24 inches on center and 1- by 4-inch side members. For tops over 60 inches wide and not exceeding 96 inches, 2- by 4-inch joists placed flat are used to support top loads. Plywood, three-eighths inch in thickness, is used full length without end joints. Tops over 96 inches in width use 2- by 4-inch joists on edge. The narrow tops are fabricated in panel form before assembly. Tops over 60 inches wide are nailed together during assembly. Calking compound for waterproofing is applied at all plywood joints just before nailing.

### Assembly

The sides, ends, and the top are nailed together as a unit, which is fastened by lag screws to the base. The size and spacing of nails are shown in figure 38.

Lag screws,  $\frac{5}{16}$  by 3 inches, fasten the sides to the stringers of the skids. The ends are fastened to the cross skids. The corners may be reinforced, if necessary, with annealed strapping, applied as listed on p. 22.

## LIGHT-DUTY SHEATHED CRATES

Light-duty type sheathed and cleated crates are intended for items of not over 1,000 pounds that require moderate mechanical protection. Outside dimensions should not exceed 12 feet in length, 5 feet in width, and 7 feet in height. Sheathing may be paper-overlaid veneer or plywood.

### Base

The base is made up of 2- by 3-inch cross skids and longitudinal skids with a diagonal at each end panel to provide stiffness (fig. 39, A). Cross skids are spaced 24 inches on center when sheathing in the side, end, and top panels is plywood, and 20 inches on center when it is paper-overlaid veneer. When a covered base is required,  $\frac{1}{4}$ -inch plywood may be used. Load-bearing floorboards as listed in table 11 are used for concentrated loads.

### Sides, Ends, and Top

The sides, ends, and top are made as shown in figure 39, B. When the sheathing is  $\frac{3}{16}$ -inch plywood, the cleats are 1 by 4 inches, spaced 24 inches on center in line with the cross skids of the base. With  $\frac{3}{16}$ -inch paper-overlaid veneer, the 1- by 4-inch cleats are spaced 20 inches on center.

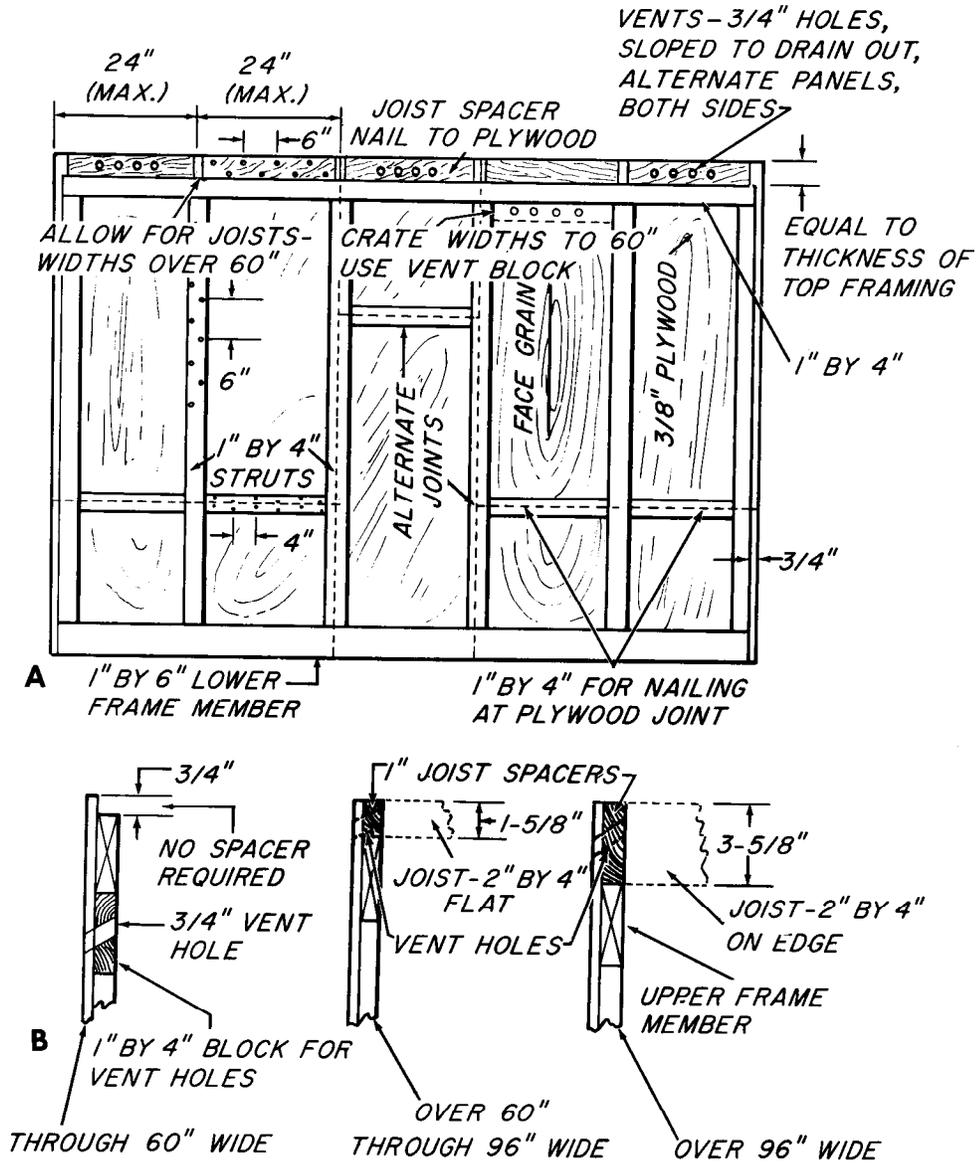

M-119700

Figure 35.—Sides for limited-military type sheathed crate: A, Side view; B, detailed construction of side panels, showing vents for crates of various widths.

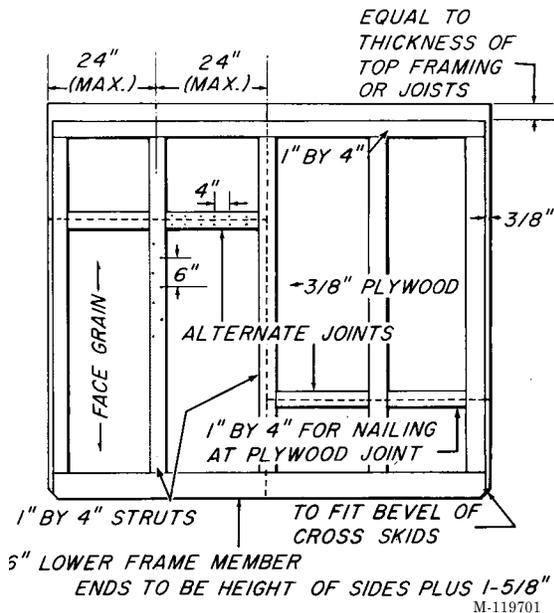

Figure 36.—Ends for limited-military type sheathed crate.

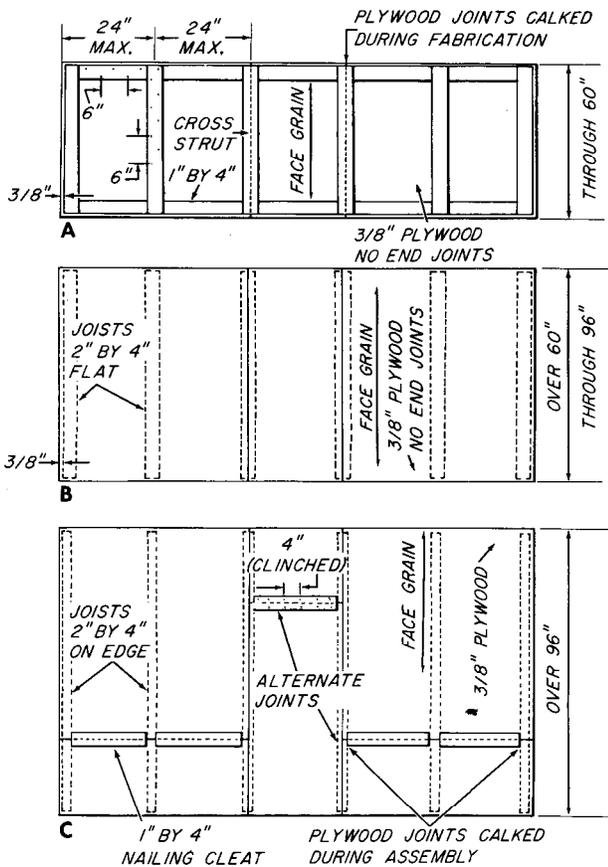

Figure 37.—Inside view of the tops of three widths of limited-military type sheathed crates: A, Narrow, B, intermediate; and C, wide.

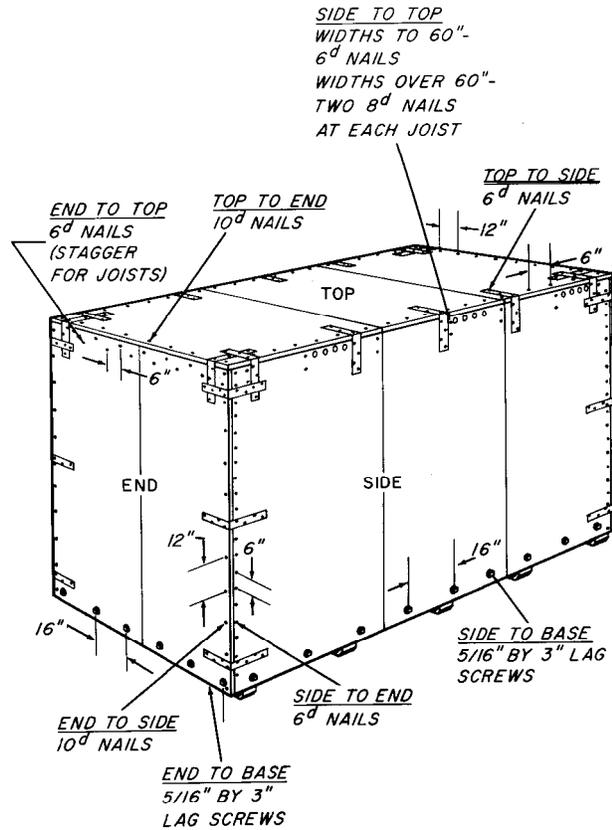
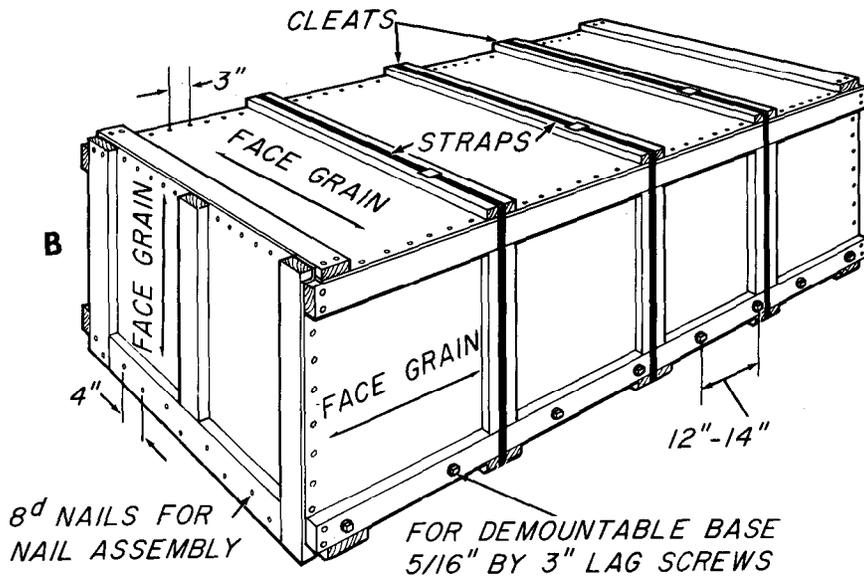
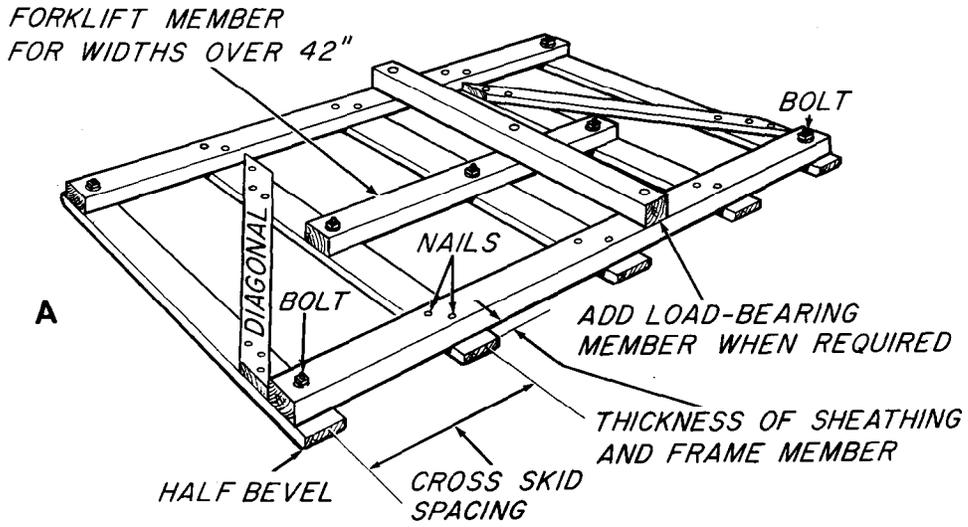

Figure 38.—Assembly of limited-military type sheathed crate.

### Assembly

The side, end, and top panels are assembled by nailing as shown in figure 39, B, and this unit is fastened to the base with nails or lag screws. Lag screws are used when semidemountability is desired. For additional strength, tension strapping may be applied as shown.



M-119704

Figure 39.—A, Construction of base; B, assembly of light-duty type cleated panel crate.

## OPEN CRATES

Open crates are most often used for packaging items not affected by weather or to be stored inside. Partial protection from the weather is sometimes provided by a waterproof shroud over the contents. Open crates are customarily assembled by either bolting or nailing. Military type open crates (fig. 40) are most often used for heavy loads.

Other types of open crates are used frequently in military and industrial shipping by truck or rail. These types are relatively light, since the components are minimum size. They resist moderate stacking loads and provide reasonable protection from handling hazards. Shrouds or partial coverings sometimes protect the item from weather. An example of the limited-military type of open crate, for loads to 2,500 pounds, is shown in figure 41. A typical light-duty crate (fig. 42) is designed for loads to 200 pounds.

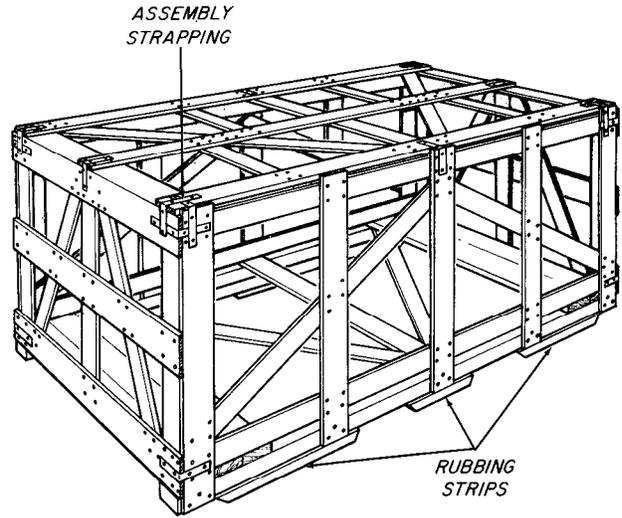

M-119656

Figure 41.—Limited-military type open crate for loads to 2,500 pounds, designed for the shipment of light, bulky items that do not require a waterproof container.

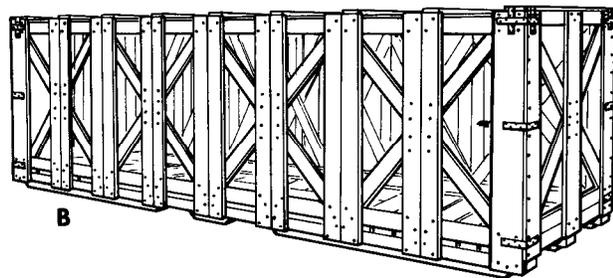
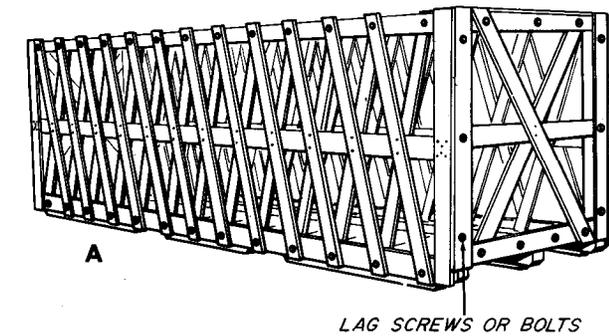

M-119655

Figure 40.—Military type open crates for loads to 10,000 pounds: A, fastened primarily with lag screws or bolts; B, nailed.

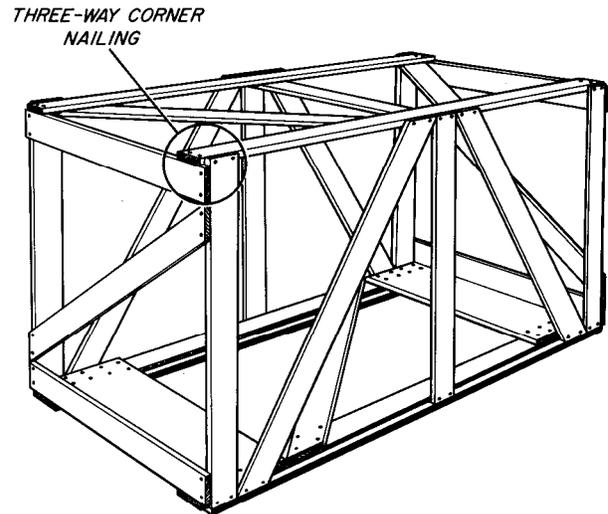

M-119657

Figure 42.—Light-duty open crate (loads to 200 pounds) with three-way corner nailing, the key to proper assembly nailing of crates of this type.

### MILITARY TYPE OPEN CRATES

Military type open crates may be used for either domestic or overseas shipments of items that do not exceed 10,000 pounds in weight. The maximum size is 16 feet long, 8 feet wide, and 8 feet high.

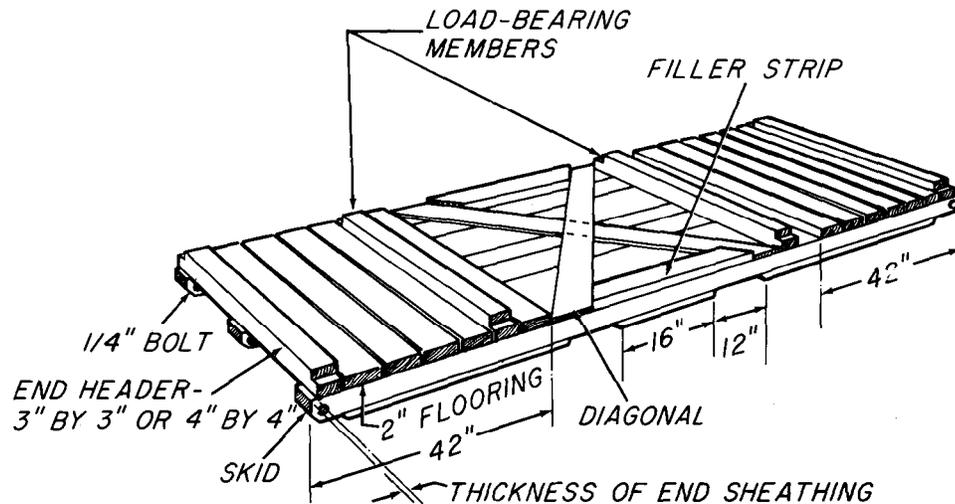

Figure 43.—Base for military type open crate.

M-119705

### Sides and Ends

The side and end panels of military type open crates are constructed as shown in figure 44. The number of panels can be determined by dividing the crate length by the height. The nearest whole number will be the correct number of panels, which enables the diagonals to form as near a 45° angle with the edge as possible. When the sides and ends are over 5 feet, high, an intermediate longitudinal member is added at the level at which the diagonals intersect.

For net loads of 6,000 to 10,000 pounds and heights that do not exceed 6 feet, size of members may be selected from table 16. When the crate is over 6 feet high, all frame members should be 2 by 4 inches. Under all conditions, the upper frame member and the struts should be at least 2 by 4's. For loads of not over 4,000 pounds and heights of less than 6 feet, all members except struts and upper frame members are 1 by 4's.

Sheathing boards are nominal 1-inch material and should provide sufficient area for nailing to the base and top members (fig. 44). For nailing to the the base, the total number of nails should be determined from table 14; the number of sheathing boards necessary for this nailing area can then be determined, using the nailing patterns of figure 6. Normally the amount of sheathing in figure 44 is sufficient, but additional boards may be required for heavy crates. Plywood strips one-half inch thick may be substituted for lumber in sides, ends, or tops and should be as wide as the total width of the sheathing boards that would be required.

When 1-inch frame members are used, 1/4-inch plywood gusset plates should be nailed at the intersection of the diagonals (fig. 44) with seven-penny nails clinched on the sheathed side. Use 12-by 12-inch sizes when diagonals are 1 by 4 inches, and 18-by 18-inch sizes when diagonals are 1 by 6's.

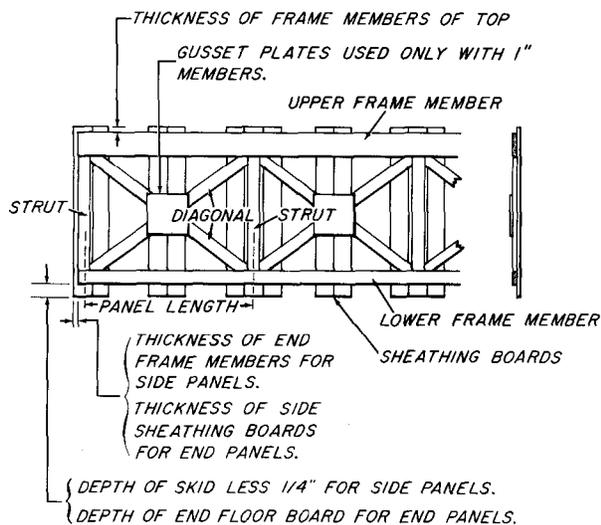

M-119706

Figure 44.—Sides or ends for military type open crates.

### Base

The base of a military type open crate is made of 4- by 4-inch skids spaced no more than 42 inches apart. To prevent splitting, carriage bolts are put through each skid, 2 to 3 inches from the ends (fig. 43). Areas for sling and forklift handling should be left between the rubbing strips. Skids are fastened together by end headers, floorboards, and diagonals. The base may be reinforced for forklift handling by 2-inch floorboards spaced three-eighths inch apart. Size of the load-bearing floorboards should be selected from table 11. Unsheathed floor areas should have single or double 1- by 6-inch diagonals.

TABLE 16.—Panel member sizes for military-type open crates designed for net loads of 6,000 to 10,000 pounds  
6,000 POUNDS

Length	Members	4-foot width and a height of—			6-foot width and a height of—			8-foot width and a height of—			
		2 feet	4 feet	6 feet	2 feet	4 feet	6 feet	2 feet	4 feet	6 feet	
Feet	6	Upper frame member	2 by 4	2 by 4	2 by 4	2 by 4	2 by 4	2 by 4	2 by 4	2 by 4	2 by 4
	Lower frame member	} 1 by 4	1 by 4	1 by 4	1 by 4	1 by 4	1 by 4	1 by 4	1 by 4	1 by 4	
	Strut										
	Diagonal										
	8	Upper frame member	2 by 4	2 by 4	2 by 4	2 by 4	2 by 4	2 by 4	2 by 4	2 by 4	2 by 4
	Lower frame member	} 1 by 4	1 by 4	1 by 4	1 by 4	1 by 4	1 by 4	1 by 4	1 by 4	1 by 4	1 by 4
	Strut										
	Diagonal										
	10	Upper frame member	2 by 4	2 by 4	2 by 4	2 by 4	2 by 4	2 by 4	2 by 4	2 by 4	2 by 4
	Lower frame member	} 1 by 4	1 by 4	1 by 4	1 by 4	1 by 4	1 by 4	1 by 4	1 by 4	1 by 4	1 by 6
	Strut										
	Diagonal										
12	Upper frame member	2 by 4	2 by 4	2 by 4	2 by 4	2 by 4	2 by 4	2 by 4	2 by 4	2 by 4	
Lower frame member	} 1 by 4	1 by 4	1 by 4	1 by 4	1 by 4	1 by 4	1 by 4	1 by 4	1 by 4	1 by 4	
Strut											
Diagonal											
16	Upper frame member	2 by 6	2 by 4	2 by 4	2 by 6	2 by 4	2 by 4	2 by 6	2 by 4	2 by 4	
Lower frame member	} 1 by 4	1 by 4	1 by 4	1 by 4	1 by 4	1 by 4	1 by 4	1 by 4	1 by 4	1 by 4	
Strut											
Diagonal											

8,000 POUNDS

Feet	6	Upper frame member	2 by 4	2 by 4	2 by 4	2 by 4	2 by 4	2 by 4	2 by 4	2 by 4	2 by 4
	Lower frame member	} 1 by 4	1 by 4	1 by 4	1 by 4	1 by 4	1 by 4	1 by 4	1 by 4	1 by 4	
	Strut										
	Diagonal										
	8	Upper frame member	2 by 4	2 by 4	2 by 4	2 by 4	2 by 4	2 by 4	2 by 4	2 by 4	2 by 4
	Lower frame member	} 1 by 4	1 by 4	1 by 4	1 by 4	1 by 4	1 by 4	1 by 4	1 by 4	1 by 4	2 by 4
	Strut										
	Diagonal										
	10	Upper frame member	2 by 4	2 by 4	2 by 4	2 by 4	2 by 4	2 by 4	2 by 4	2 by 4	2 by 4
	Lower frame member	} 1 by 4	1 by 4	1 by 4	1 by 4	1 by 4	1 by 4	1 by 4	1 by 4	1 by 4	1 by 4
	Strut										
	Diagonal										
12	Upper frame member	2 by 6	2 by 4	2 by 4	2 by 6	2 by 4	2 by 4	2 by 6	2 by 4	2 by 4	
Lower frame member	} 1 by 4	1 by 4	1 by 4	1 by 4	1 by 4	1 by 4	1 by 4	1 by 4	1 by 4	1 by 4	
Strut											
Diagonal											
16	Upper frame member	2 by 6	2 by 4	2 by 4	2 by 6	2 by 4	2 by 4	2 by 6	2 by 4	2 by 4	
Lower frame member	} 1 by 4	1 by 4	1 by 4	1 by 4	1 by 4	1 by 4	1 by 4	1 by 4	1 by 4	1 by 4	
Strut											
Diagonal											

10,000 POUNDS

Feet	6	Upper frame member	2 by 4	2 by 4	2 by 4	2 by 4	2 by 4	2 by 4	2 by 4	2 by 4	2 by 4
	Lower frame member	} 1 by 4	1 by 4	1 by 4	1 by 4	1 by 4	1 by 4	1 by 4	1 by 4	1 by 4	
	Strut										
	Diagonal										
	8	Upper frame member	2 by 4	2 by 4	2 by 4	2 by 4	2 by 4	2 by 4	2 by 4	2 by 4	2 by 4
	Lower frame member	} 1 by 4	1 by 4	2 by 4	1 by 4	1 by 4	2 by 4	1 by 4	1 by 4	1 by 6	2 by 4
	Strut										
	Diagonal										
	10	Upper frame member	2 by 4	2 by 4	2 by 4	2 by 4	2 by 4	2 by 4	2 by 4	2 by 4	2 by 4
	Lower frame member	} 1 by 4	1 by 4	1 by 4	1 by 4	1 by 4	1 by 4	1 by 4	1 by 4	1 by 4	1 by 4
	Strut										
	Diagonal										

TABLE 16.—Panel member sizes for military-type open crates designed for net loads of 6,000 to 10,000 pounds—Continued

10,000 POUNDS—Continued

Length	Members	4-foot width and a height of—			6-foot width and a height of—			8-foot width and a height of—		
		2 feet	4 feet	6 feet	2 feet	4 feet	6 feet	2 feet	4 feet	6 feet
Feet		<i>Inches</i>	<i>Inches</i>	<i>Inches</i>	<i>Inches</i>	<i>Inches</i>	<i>Inches</i>	<i>Inches</i>	<i>Inches</i>	<i>Inches</i>
	12	Upper frame member... 2 by 6	2 by 4	2 by 4	2 by 6	2 by 4	2 by 4	2 by 6	2 by 4	2 by 4
	Lower frame member... 1 by 4	1 by 4	1 by 4	1 by 4	1 by 4	1 by 4	2 by 4	1 by 4	1 by 4	2 by 4
	Strut... 1 by 4	1 by 4	1 by 4	1 by 6	1 by 4	1 by 4	2 by 4	1 by 4	1 by 4	2 by 4
	Diagonal... 1 by 4	1 by 6	1 by 6	1 by 6	1 by 6	1 by 6	2 by 4	1 by 6	1 by 6	2 by 4
16	Upper frame member... 2 by 8	2 by 6	2 by 6	2 by 4	2 by 8	2 by 6	2 by 4	2 by 8	2 by 6	2 by 4
	Lower frame member... 1 by 4	1 by 4	1 by 4	1 by 4	1 by 4	1 by 4	2 by 4	1 by 4	1 by 4	2 by 4
	Strut... 1 by 4	1 by 4	1 by 4	1 by 4	1 by 4	1 by 4	2 by 4	1 by 4	1 by 6	2 by 4
	Diagonal... 1 by 6	1 by 6	1 by 6	1 by 6	1 by 6	1 by 6	2 by 4	1 by 6	1 by 6	2 by 4

### Tops

The tops of military type open crates of various widths are constructed as shown in figure 45. Frame members are nominal 1 by 6's or, if the tops are not more than 24 inches wide, 1 by 4's. Plywood gussets should be added to the intersection of all cross diagonals. Sheathing is applied as described for the sides and ends.

### Assembly

Military type open crates are assembled as shown in figure 46 and as described in the section on sheathed crate assembly. Strapping may be used for reinforcing, applied as listed on p. 22.

### LIMITED-MILITARY TYPE OPEN CRATES

Limited-military type open crates, also for domestic or overseas shipment, are of three styles, sizes, and load capacities. They are not designed for large superimposed top loads, so heavy joist systems are not included. However, the sides and ends are capable of withstanding moderate top loads such as might be imposed by normal like-on-like stacking.

### Styles A and A-1 Open Crates

A style A open crate (fig. 47) has a load limit of 1,000 pounds, with maximum dimensions of 6 feet in length and 4 feet in width and height. The base is made up of 2- by 4-inch skids and end headers for loads of not over 500 pounds and 2 by 6's for loads of not over 1,000 pounds. Rubbing strips are 2 by 4's. Dimensions of load-bearing floorboards can be selected from table 11. All members of the sides, ends, and top, as well as the diagonal of the base, are 1 by 6's.

A similar style, A-1, uses all 1- by 4-inch members for side, end, and top panels (fig. 48). The

weight limitation is 250 pounds. Maximum dimensions are 4 feet in length and 3 feet in width and height. Skids and end headers are also 2 by 4's. Both styles A and A-1 employ eightpenny sinker nails spaced 6 to 8 inches apart for side-to-end and end-to-top assembly. The sides are nailed to the base as in figure 6; ends are not fastened directly to the base. The crate may be strengthened by metal strips (fig. 48).

### Style B Open Crates

Style B (fig. 49) is similar to style A except that the maximum load is 2,500 pounds, and the maximum dimensions are 12 feet in length and 6 feet in width and height.

The base is made up of 4- by 4-inch skids; three skids are used when the distance between outside skids is more than 36 inches. Rubbing strips are 2 by 4's. End headers are 2 by 6's for crates that do not exceed 4 feet in width and 4 by 4's for widths over 4 feet. Dimensions of load-bearing floorboards can be selected from table 11.

The sides are made of 1 by 6's. A crate over 48 inches high needs an intermediate horizontal member. Space struts not over 40 inches apart, so that the angle formed by the diagonal is as near 45° as possible.

The struts of the end are 2 by 4's. An intermediate strut is added when the crate is over 42 inches wide. Other members are 1 by 6's, except that a 1- by 8-inch lower edge member is needed when the end cross members of the base are 4 by 4's.

All members of the top are 2 by 4's. A top over 42 inches wide needs an intermediate longitudinal member, aligned with the center strut of the end. The joists are placed flat and aligned with the struts of the side panel. Each end panel of the top has a diagonal (fig. 49).

Style B crates may be assembled either with eightpenny sinker nails in the same manner as

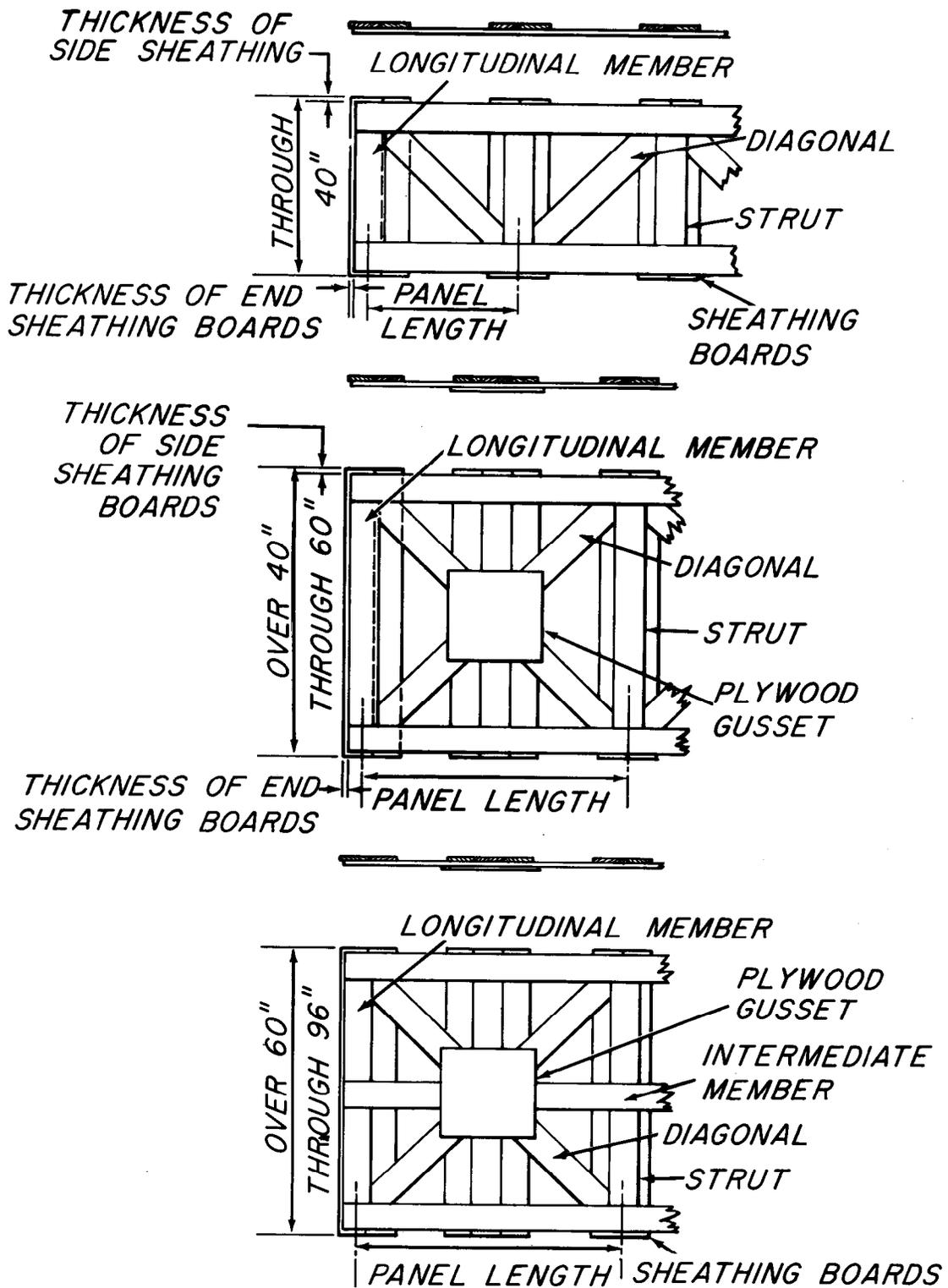

M-119707

Figure 45.—Narrow, intermediate, and wide tops for military type open crates.

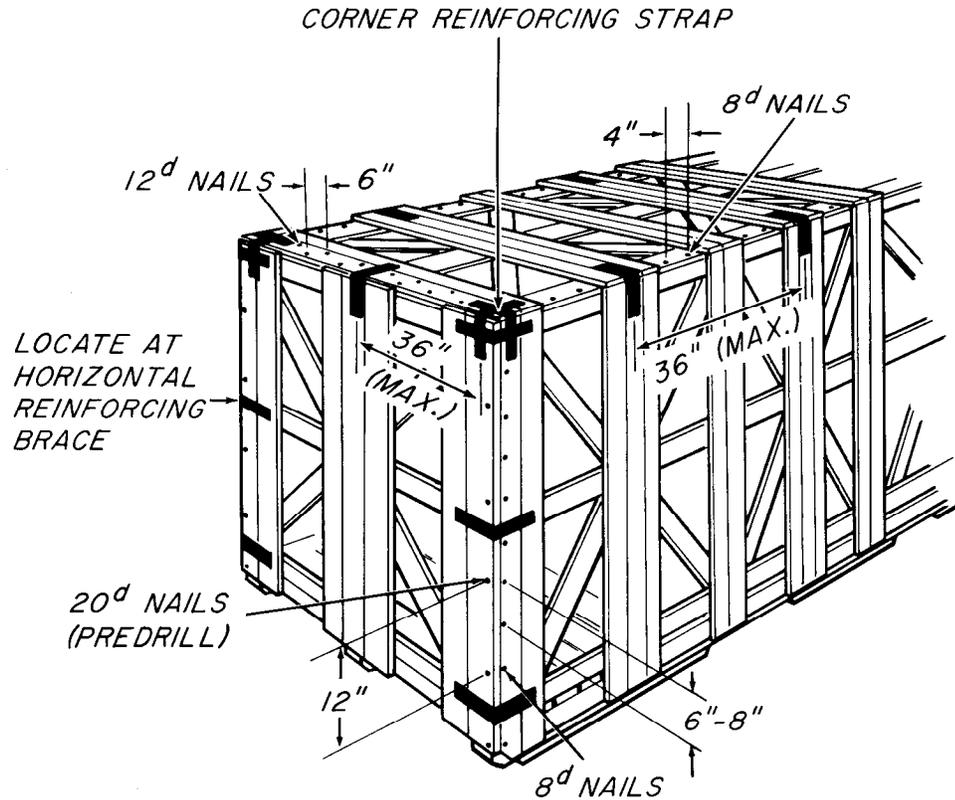

M-119708

Figure 46.—Assembly of military type open crate.

style A and A-1 crates or with lag screws. The crate is strengthened by steel straps (fig. 49). The diagonals are arranged to provide the maximum number of fastening points to the base near the center of the skid depth.

If lag screws are employed for side-to-base fastening they should be  $\frac{3}{8}$  inch. The minimum number of lag screws for each side is shown in the following tabulation, but at least one must be placed in each strut and diagonal.

Gross load—crate and contents (pounds)	Minimum lag screws for each side (number)
1,000	4
2,000	5
3,000	8
4,000	10

If lag screws are used for end-to-base, side-to-end, and end-to-top assembly, they should be  $\frac{5}{16}$ - by 3-inch spaced 12 to 14 inches apart. Each strut and diagonal of the side panel is joined by a lag screw of the same size to the edge longitudinal member of the top.

### Style C Open Crates

A style C open crate of the limited-military type often is used for shipping such high-density items as sheet metal and sheets of building board. Crates of this type should not exceed 12 feet in length, 4 feet in width, and 2 feet in height. When no blocking or bracing is required the maximum gross load is 1,000 pounds. When the item requires bracing or cushioning the maximum load is 500 pounds. Crates may be made entirely of lumber, or of cleated plywood sides and ends with lumber cross members in tops and bottoms (fig. 50).

The sizes of plywood or lumber for the ends and sides are listed in table 17.

When sides are made of two or more pieces of lumber, inside battens of the same size as the cleats should be alined with top and bottom cross members and spaced no more than 36 inches apart (fig. 50).

The top and bottom cross members and diagonals are 1 by 4's for crates 30 inches wide or less and 1 by 6's for crates wider than 30 inches.

The sides are nailed to the ends with sinker nails. Nail sizes and spacings for different

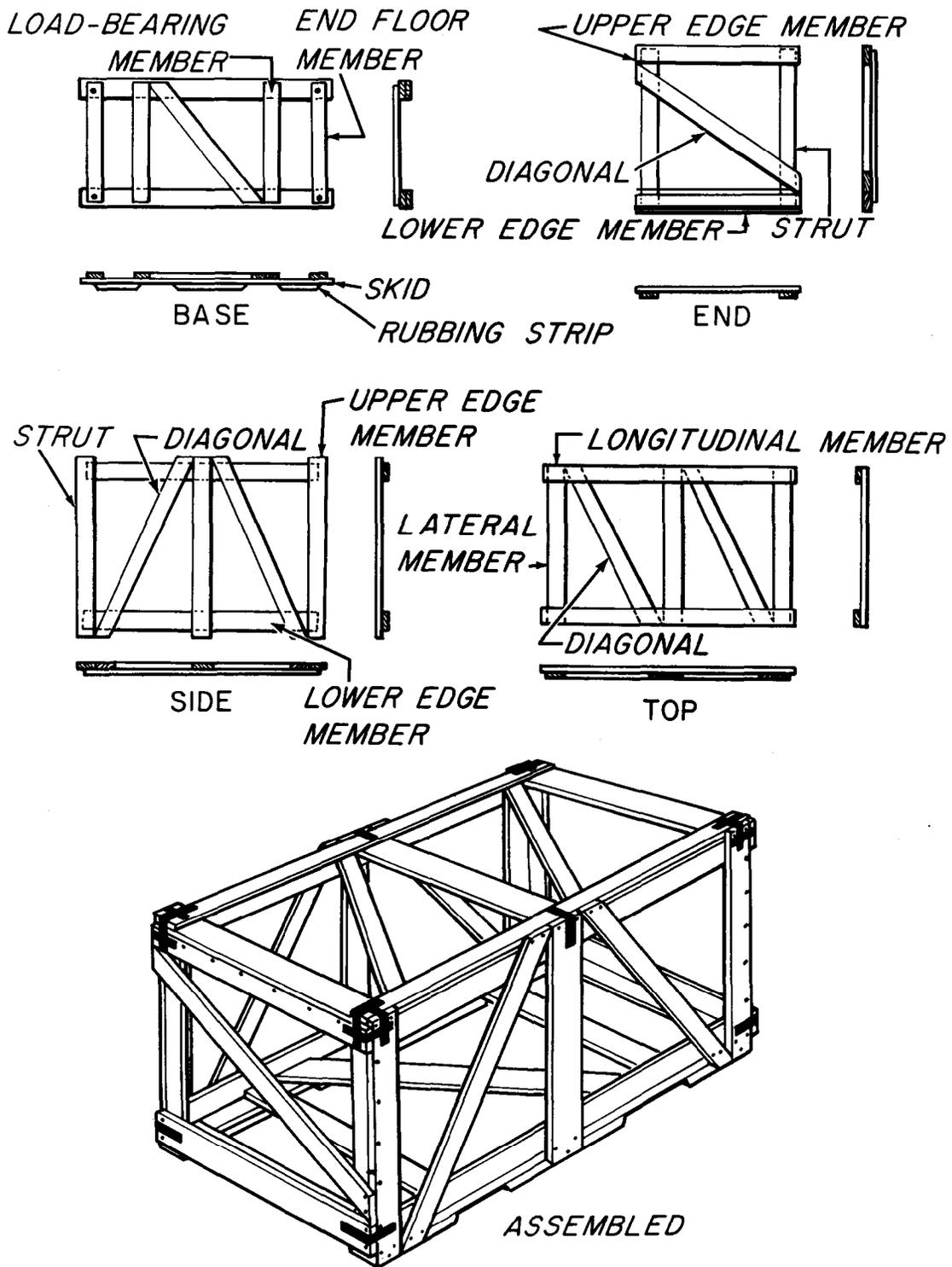

Figure 47.—Style A limited-military type open crate.

M-119709

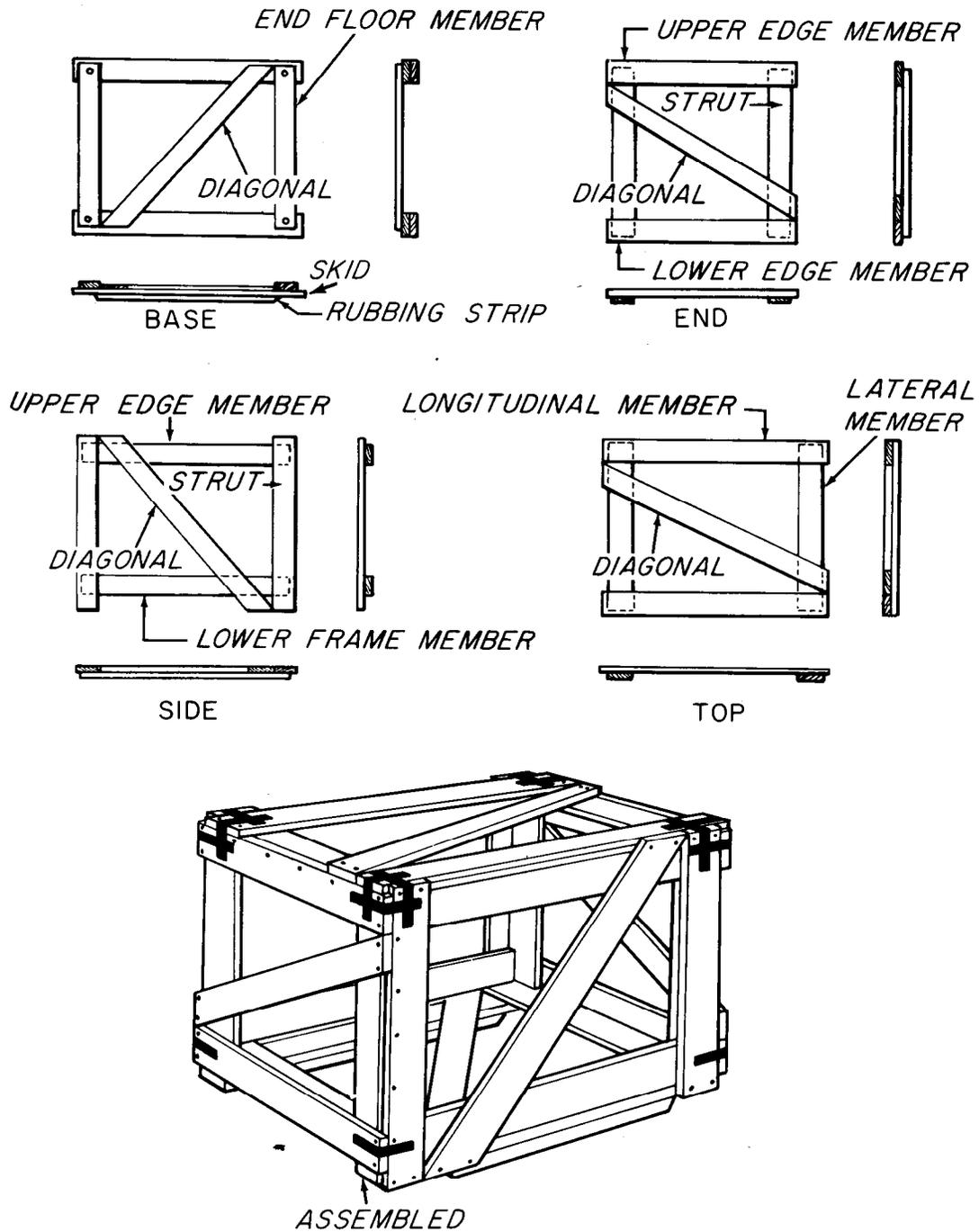

Figure 48.—Style A-1 limited-military type open crate.

M-119710

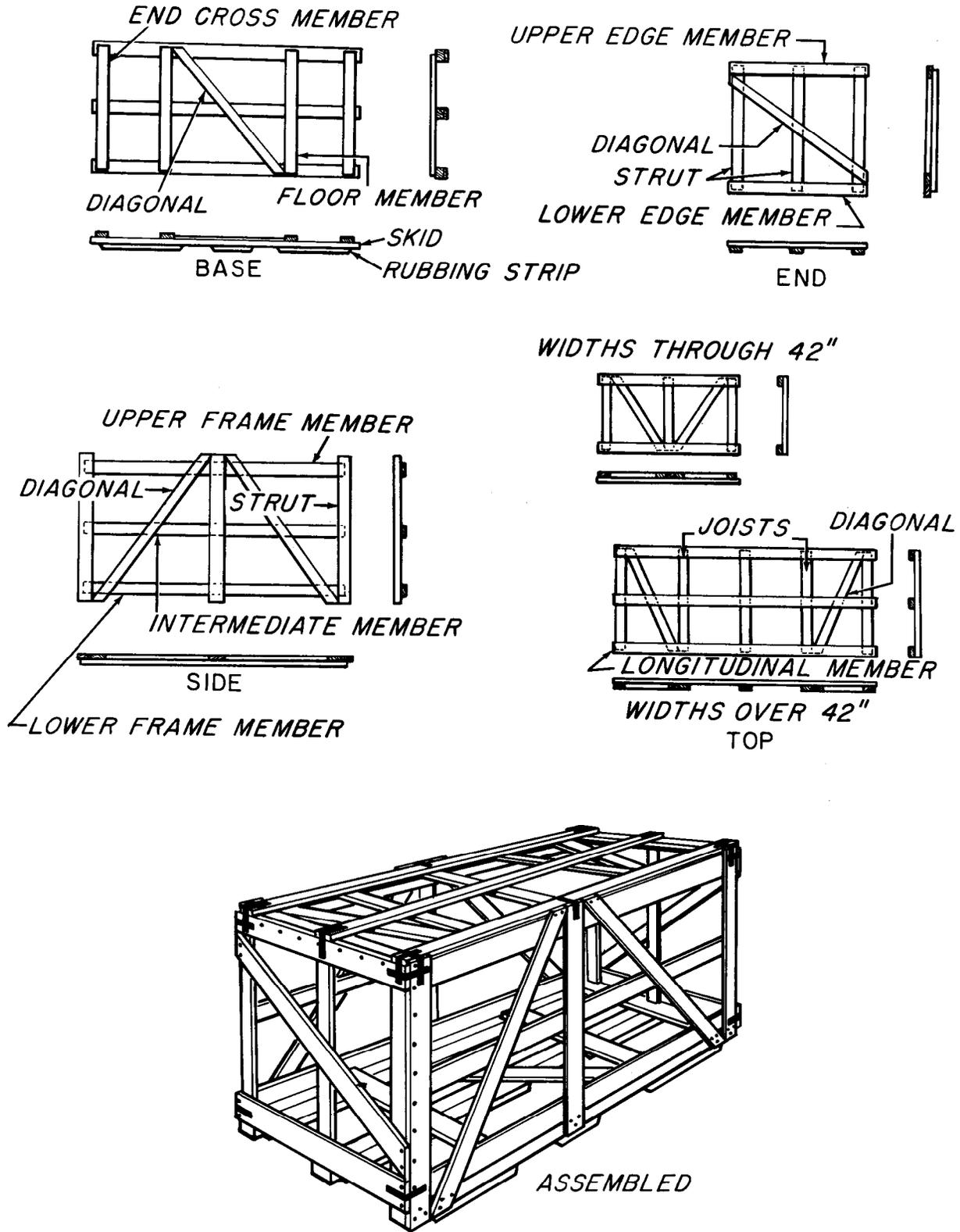
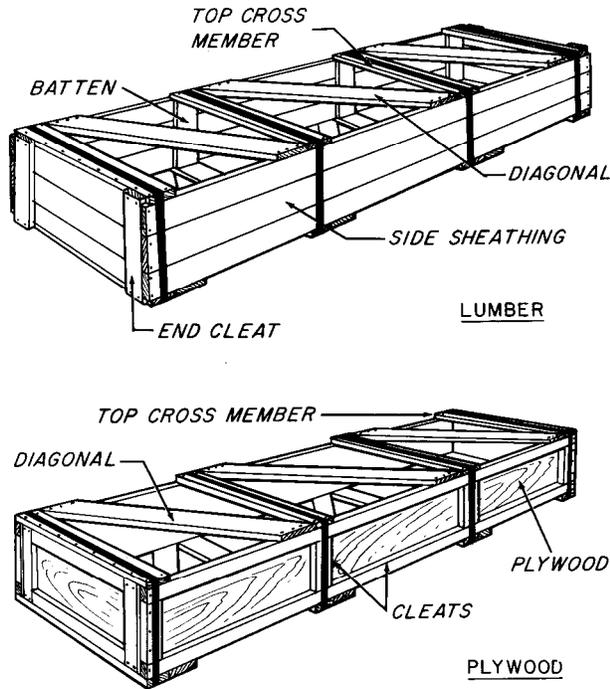

Figure 49.—Style B limited-military type open crate.

M-110711



M-119712

Figure 50.—Style C limited-military type open crates of lumber and plywood-and-lumber construction.

thicknesses of either lumber or cleated plywood sides are given in table 18.

The top and bottom members are nailed to the sides with eightpenny sinker nails. Tension strapping is used to reinforce top and bottom members (fig. 50) when shipping conditions are moderate to severe.

TABLE 17.—Size of material for the ends and sides of a Style C open crate of the limited-military type

Maximum net load	Thickness of ends and sides		Size of end cleats	Size of side cleats
	Plywood	Lumber		
<i>Pounds</i>	<i>Inch</i>	<i>Inches</i>	<i>Inches</i>	<i>Inches</i>
100-----	1/4	3/4	3/4 by 2 3/4	3/4 by 2 3/4
250-----	5/8	3/4	3/4 by 3 3/8	3/4 by 2 3/4
500-----	1/2	1 1/16	1 1/16 by 3 5/8	7/8 by 3 5/8
1,000-----	1/2	1 1/16	1 5/8 by 3 5/8	7/8 by 3 5/8

**LIGHT-DUTY OPEN CRATES**

Crates of this type are designed principally to protect items from normal shipping and storage hazards, including accidental drops, with minimum material and tare weight. They are intended for

domestic or low-hazard shipment of items that do not exceed 4,000 pounds. They should be a maximum of 32 feet long, 6 feet wide, and 10 feet high. They may be fastened entirely by nails or made partially demountable by nailing together the sides, ends, and top and then fastening to the base with lag screws. The tops are designed not to carry superimposed loads. The sides and ends can resist the moderate stresses of like-on-like stacking.

TABLE 18.—Spacing of sinker nails in lumber or plywood sides of a style C open crate of the limited-military type

Nail size	Cleated plywood sides		Lumber sides	
	Plywood thickness	Nail spacing	Thickness	Nail spacing
<i>Penny</i>	<i>Inch</i>	<i>Inches</i>	<i>Inches</i>	<i>Inches</i>
8-----	3/4	3	3/4	2 1/2
10-----	5/8	3 3/4	1 1/16	2 3/4
12-----	1/2	3 1/2	1 1/16	3

Auxiliary coverings of 3/16-inch plywood or paper-overlaid veneer may be used on crates for items that require the protection of some sheathing. Filler pieces are added to the frame to provide nailing surfaces at the edges of panels.

**Base**

Skids are single-piece 2 by 4's, placed flat, for loads of not over 2,000 pounds and bases no longer than 20 feet. For loads that do not exceed 3,000 pounds and lengths no more than 20 feet, skids should be single-piece 3 by 3's. With heavier loads or longer bases, the skids should be 4 by 4's, or two 2 by 4's laminated and placed on edge. Crates over 42 inches wide need three skids (fig. 51). Rubbing strips are fastened under each skid, with spaces left for forklift or sling handling.

End headers are the same size as the skids (fig. 51). Load-bearing floorboard sizes are selected from table 11. Other cross members and diagonals should be 1 by 4's for loads that do not exceed 500 pounds and crate widths of not over 36 inches, 1 by 6's for wider crates or heavier loads.

**Sides**

The light-duty open crate has one of three styles of sides, depending on the net load and crate height.

For loads of not over 2,000 pounds and crate heights of no more than 6 feet, sides of the style in figure 52 should be used. The sizes of members and the spacing of struts for crates of various dimensions are listed in table 19.

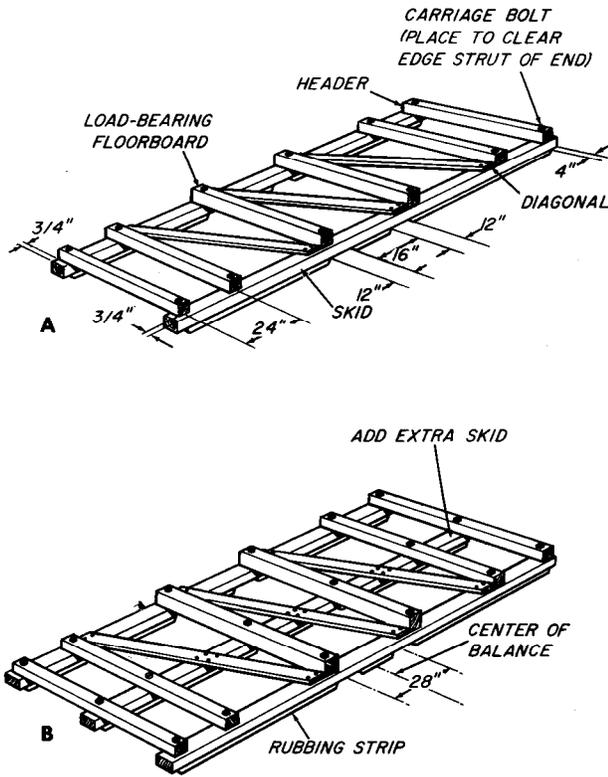

M-119713

Figure 51.—Bases for light-duty open crater: A, Through 42 inches wide; B, over 42 inches wide.

The double-panel side design (fig. 53) is for loads that do not exceed 4,000 pounds and heights no greater than 8 feet. Member sizes and strut spacing are listed in table 20.

The triple-panel side design (fig. 54) is for loads of no more than 4,000 pounds and heights be-

tween 8 and 10 feet. Member sizes and strut spacing are listed in table 21.

### Ends

The arrangement of members in the ends (figs. 55, 56) is determined by the height and width of the crate and by the strut spacing. The strut spacing should be no greater than for the side struts. The upper frame members, intermediate horizontal members, struts, and diagonals are 1 by 4's for loads through 500 pounds and 1 by 6's for loads over 500 pounds, except that struts should be 2 by 4's in crates over 5 feet high. The lower frame member is a 1 by 6 with 2- by 4-inch single end headers placed flat, and a 1 by 8 with larger headers.

### Tops

The design and arrangement of members of the top are usually based on the width of the crate. The styles of tops for widths through 72 inches are shown in figure 57. Edge longitudinal members are 1 by 4's for loads not exceeding 500 pounds and widths through 48 inches, and 1 by 6's for all other conditions. Center longitudinal members for wide crates are 1 by 4 inches. Cross struts and diagonals should be 1 by 4's for loads not exceeding 1,000 pounds and widths through 48 inches, and 1 by 6's for heavier loads and wider crates.

### Assembly

The method of assembly for the light-duty open crate is shown in figure 58. Assembly of the covered style is shown in figure 59.

TABLE 19.—Strut spacing and frame member sizes <sup>1</sup> for sides of single-panel light-duty open crates

Crate size limits					Member sizes of sides				
Length	Width	Height	Net load	Maximum strut spacing (on center)	Upper longitudinal	Lower longitudinal	Intermediate <sup>2</sup> longitudinal	Strut	Diagonal
<i>Feet</i>	<i>Inches</i>	<i>Inches</i>	<i>Pounds</i>	<i>Inches</i>	<i>Inches</i>	<i>Inches</i>	<i>Inches</i>	<i>Inches</i>	<i>Inches</i>
12	48	48	300	42	1 by 4	1 by 3	-----	1 by 3 <sup>3</sup>	1 by 4
32	60	60	500	48	1 by 6	1 by 4	1 by 3	1 by 4	1 by 4
24	60	72	1,000	42	1 by 6	1 by 6	1 by 4	1 by 4 <sup>3</sup>	1 by 6
20	60	72	1,500	42	1 by 6	1 by 6	1 by 4	1 by 6	1 by 6
16	60	72	2,000	36	1 by 8	1 by 6	1 by 6	1 by 6	1 by 6

<sup>1</sup> Longitudinal members shall be single pieces for lengths that do not exceed 16 feet, with approved splices permitted in lengths greater than 16 feet.

<sup>2</sup> For crates over 48 inches high.

<sup>3</sup> For edge struts, use 1 by 4's. But if edge struts of ends are 2 by 4's, use 1 by 6's for edge struts of sides.

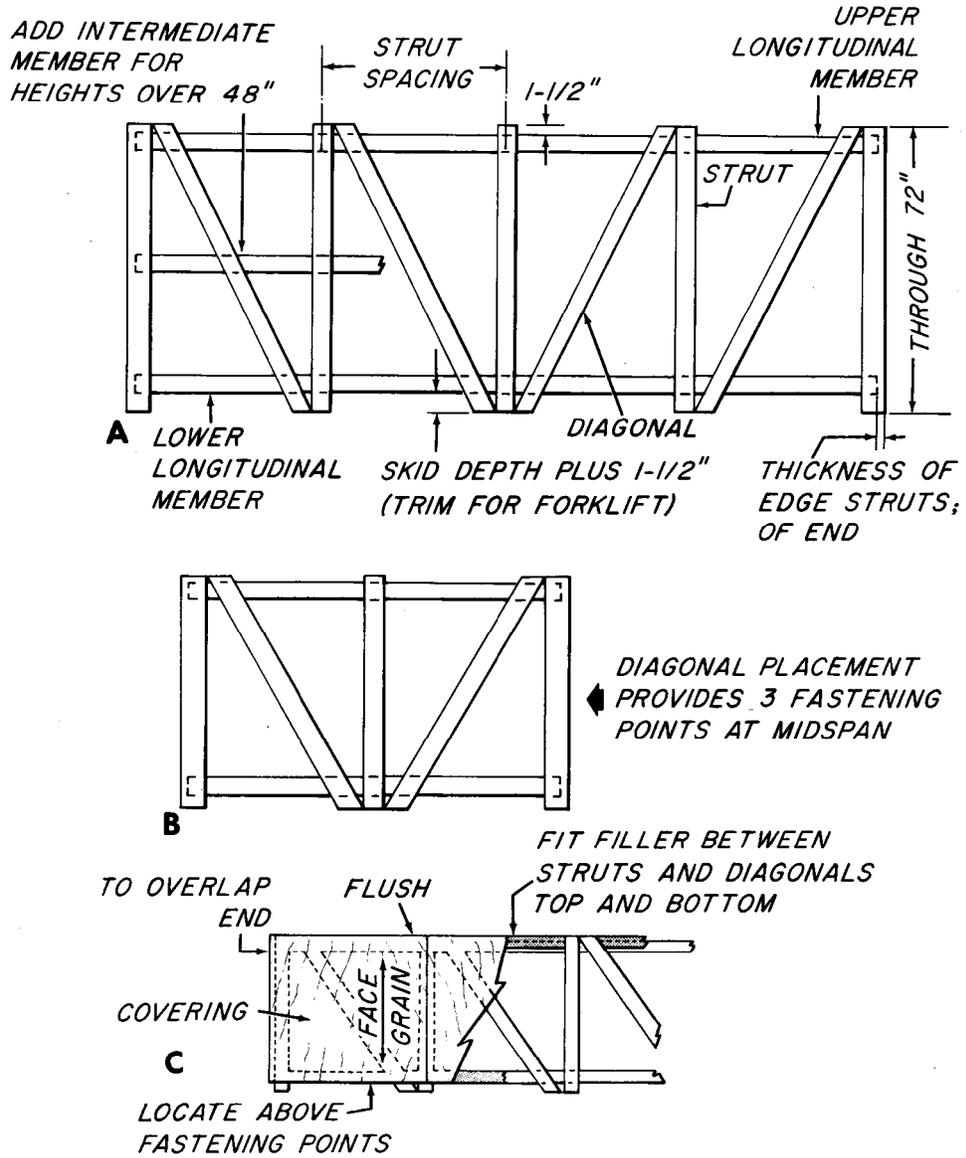

M-119714

Figure 52.—Sides for light-duty open crates, for loads through 4,000 pounds and heights through 6 feet: A, Side view; B, side of short crate; C, covered side.

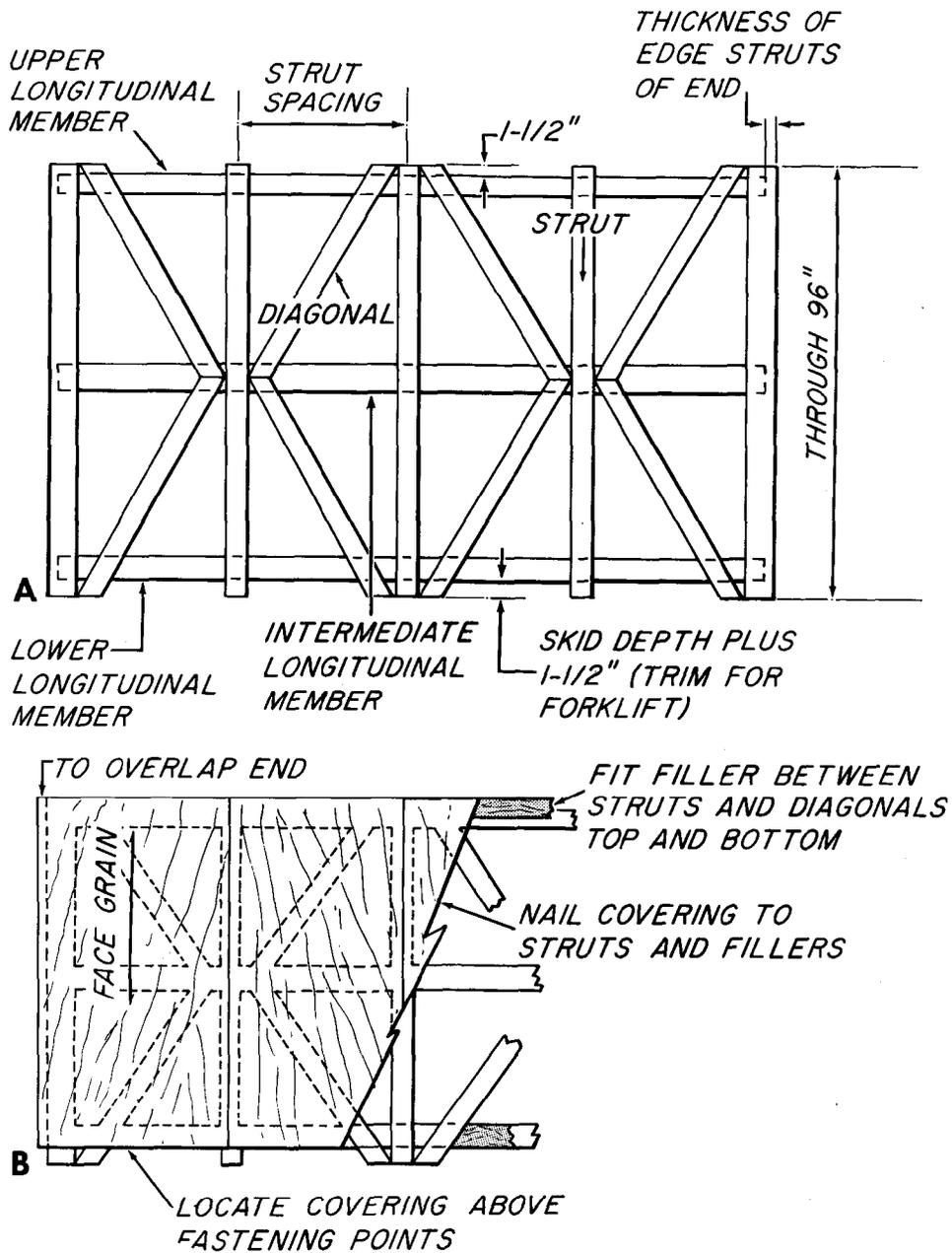

M-119715

Figure 53.—Double-panel sides for light-duty open crates, for loads through 4,000 pounds and heights through 8 feet: A, Side view; B, covered side.

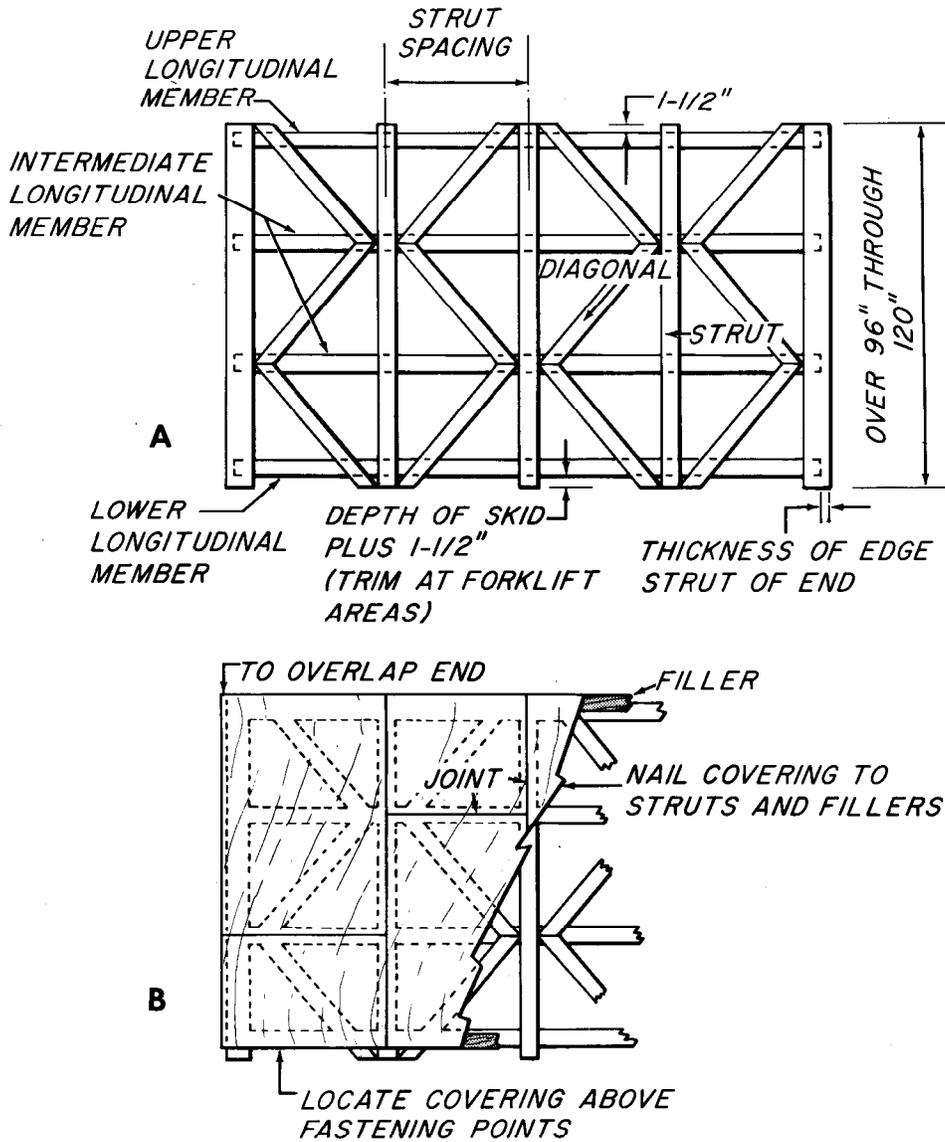

M-119716

Figure 54.—Triple-panel sides for light-duty open crates, for loads through 4,000 pounds and heights between 8 and 10 feet: A, Side view; B, covered side.

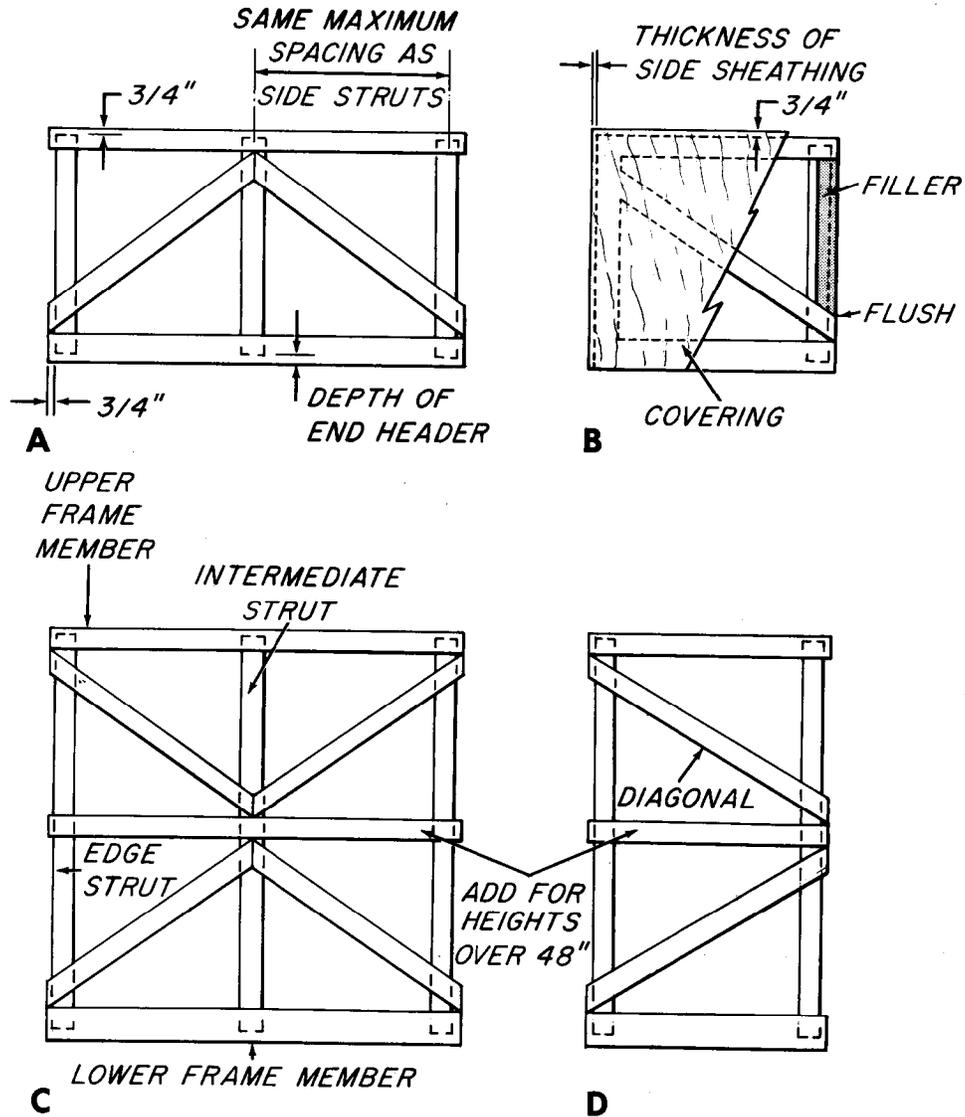

M-119717

Figure 55.—Ends for light-duty open crates, for loads through 2,000 pounds and heights through 8 feet: A, Two-panel horizontal; B, single-panel (covered); C, four-panel; and D, two-panel vertical.

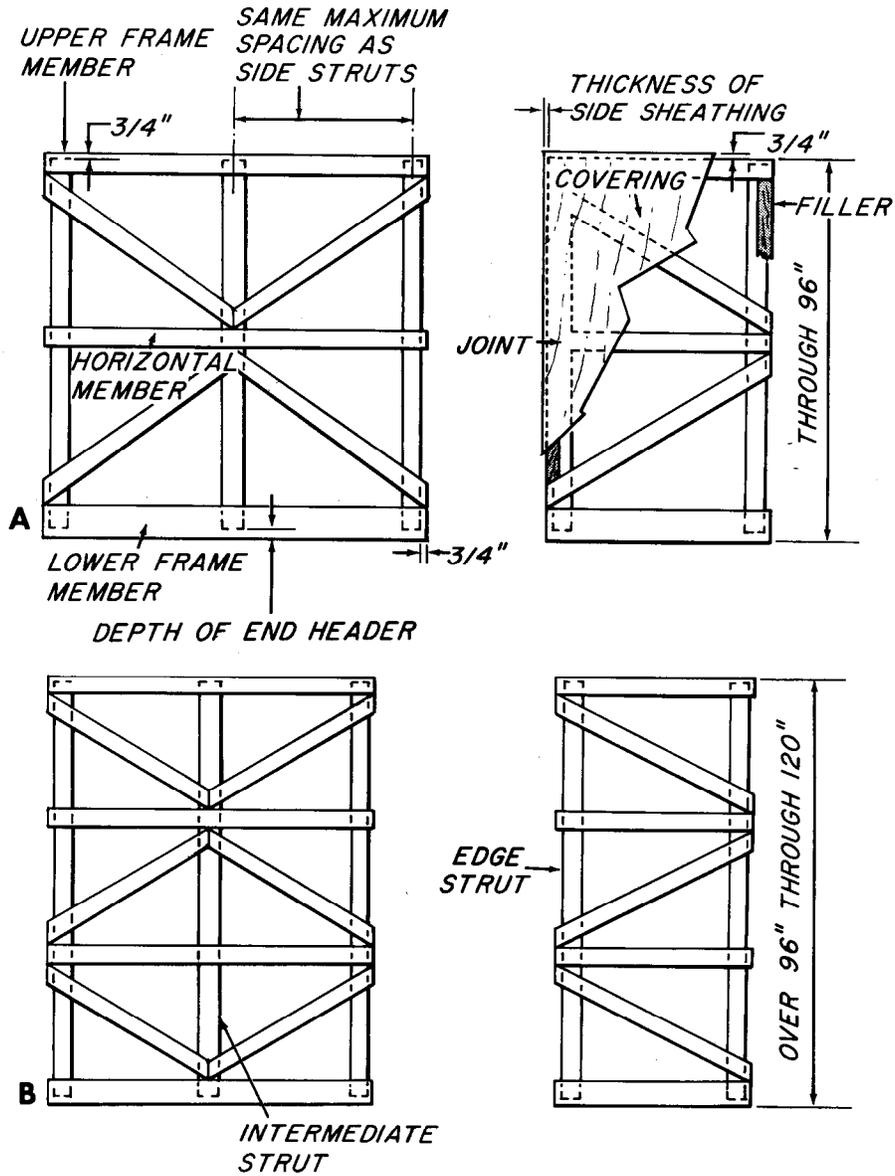

M-119718

Figure 56.—Ends for light-duty open crates, for loads through 4,000 pounds and heights through 10 feet: A, Wide and narrow double-panel ends; and B, wide and narrow triple-panel ends.

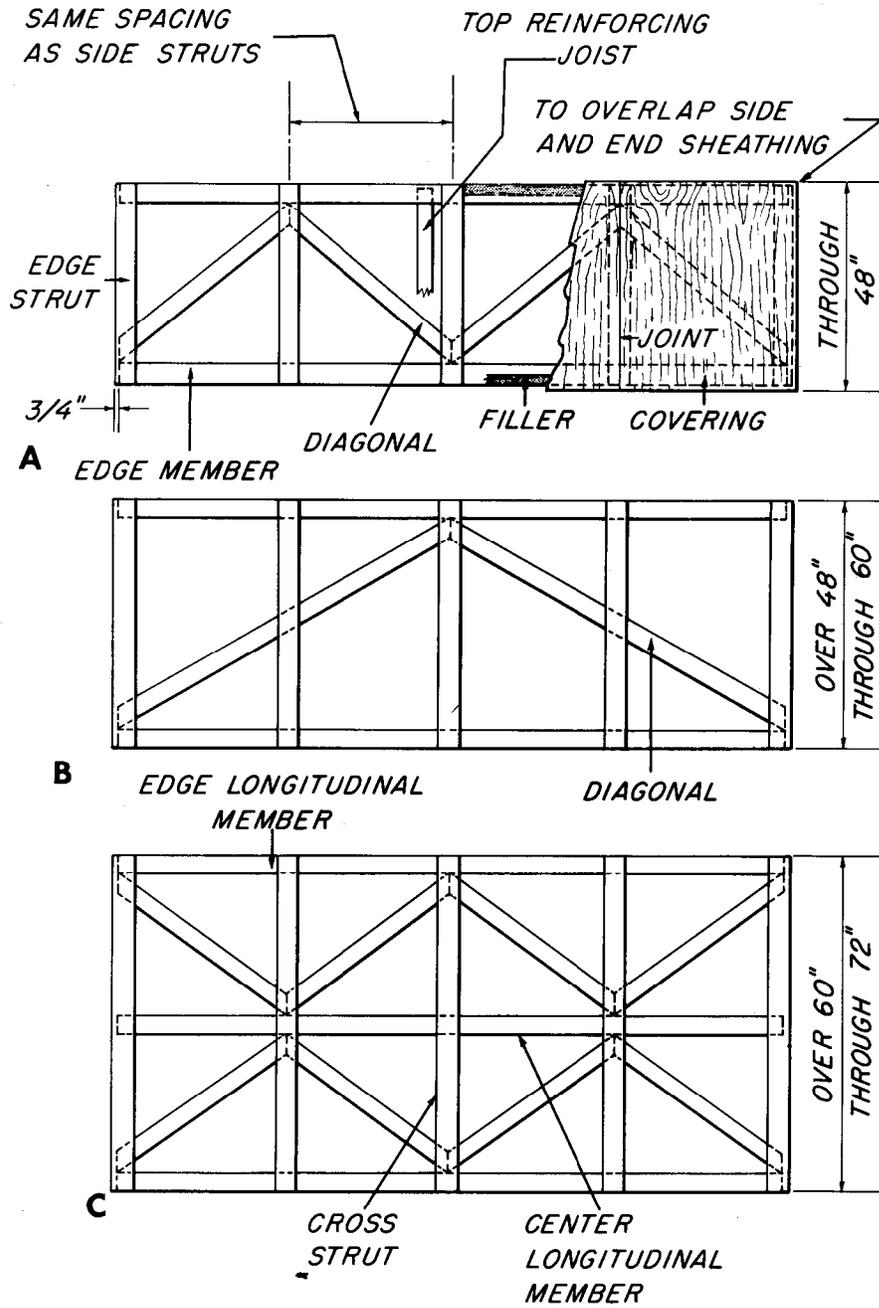

M-119909

Figure 57.—Tops for light-duty open crates: A, narrow top; B, medium-width top; C, wide top.

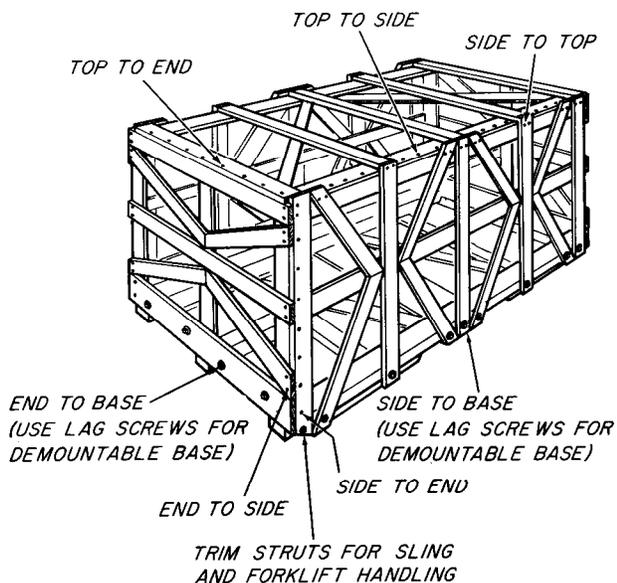

M-119719

Figure 58.—Assembly of light-duty open crate.

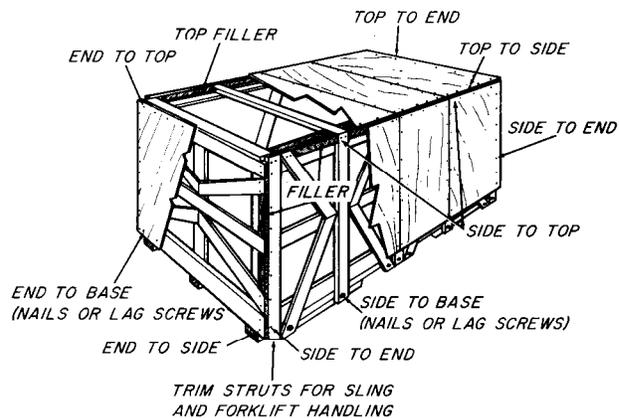

M-119702

Figure 59.—Assembly of covered style light-duty open crate

TABLE 20.—Strut spacing and frame member sizes <sup>1</sup> for sides of double-panel light-duty open crates

Crate size limits					Member sizes of sides				
Length	Width	Height	Net load	Maximum strut spacing (on center)	Upper longitudinal	Lower longitudinal	Intermediate longitudinal	Strut	Diagonal
<i>Feet</i>	<i>Inches</i>	<i>Inches</i>	<i>Pounds</i>	<i>Inches</i>	<i>Inches</i>	<i>Inches</i>	<i>Inches</i>	<i>Inches</i>	<i>Inches</i>
32-----	72	96	500	54	1 by 4	1 by 4	1 by 6	1 by 4 <sup>2</sup>	1 by 4
28-----	72	96	1, 000	54	1 by 6	1 by 4	1 by 6	1 by 4 <sup>2</sup>	1 by 4
24-----	72	96	2, 000	48	1 by 6	1 by 6	1 by 6	1 by 6	1 by 6
20-----	72	96	3, 000	48	1 by 8	1 by 6	1 by 6	1 by 6	1 by 6
16-----	72	96	4, 000	42	1 by 8	1 by 8	1 by 8	1 by 6 <sup>3</sup>	1 by 6

<sup>1</sup> Longitudinal members shall be in single pieces for lengths that do not exceed 16 feet, with approved splices permitted in lengths greater than 16 feet.

<sup>2</sup> Edge struts 1 by 6 inch minimum.  
<sup>3</sup> Edge struts 1 by 8 inch minimum.

TABLE 21.—Strut spacing and frame member sizes <sup>1</sup> for sides of triple-panel light-duty open crates

Crate size limits					Member sizes of sides				
Length	Width	Height	Net load	Maximum strut spacing (on center)	Upper longitudinal	Lower longitudinal	Intermediate longitudinal	Strut	Diagonal
<i>Feet</i>	<i>Inches</i>	<i>Inches</i>	<i>Pounds</i>	<i>Inches</i>	<i>Inches</i>	<i>Inches</i>	<i>Inches</i>	<i>Inches</i>	<i>Inches</i>
32-----	72	120	500	54	1 by 4	1 by 4	1 by 4	1 by 4 <sup>2</sup>	1 by 4
28-----	72	120	1, 000	54	1 by 6	1 by 4	1 by 6	1 by 6	1 by 4
24-----	72	120	2, 000	48	1 by 6	1 by 6	1 by 6	1 by 6	1 by 4
20-----	72	120	3, 000	48	1 by 8	1 by 6	1 by 6	1 by 6 <sup>3</sup>	1 by 6
16-----	72	120	4, 000	42	1 by 8	1 by 8	1 by 8	1 by 8	1 by 6

<sup>1</sup> Longitudinal members shall be in single pieces for lengths that do not exceed 16 feet, with approved splices permitted in lengths greater than 16 feet.

<sup>2</sup> Edge struts 1 by 6 inch minimum.  
<sup>3</sup> Edge struts 1 by 8 inch minimum.

## SKID ASSEMBLIES

Instead of crates, it is sometimes sufficient to use heavy skid and cross member assemblies under large rugged articles such as machine tools, so that they can be more easily handled and transported.

In designing the skid assembly, the length and width of the item, its weight, type of base, and its unsupported span (the distance between the base contacts with the skid) are factors that must be considered. The number of skids is determined by the load-carrying capacity of a skid, the requirements for securing the equipment, and whether there are any projecting parts. Skids should be not less than 2 by 4 inches with their width usually not less than three-fifths of the depth.

In order to use the tables that give requirements for skids and floorboards, a weight-length value ( $WL$ ) must be obtained by multiplying the actual weight of the item ( $W$ ) by the unsupported span ( $L$ ). It is suggested that a sketch of the skid assembly be made so all factors are included.

To help in determining the floorboard requirements, the unsupported span, and the skid-size, items have been classified into two groups (fig. 60). Open-type base articles have two or more legs,

columns, or similar supports. Closed-type base articles have one support.

### SKID SIZES

The length and width of skid assemblies are usually determined by the overall length and width of the item. These dimensions include projecting arms or levers that cannot be further disassembled. When necessary, additional length must be provided for an end cross member (header) of the same width and depth as the skid, positioned flatwise. With the overall measurements known, the proper  $L$  distances can be decided.

In calculating skid sizes, the  $L$  value of open-type bases is either the distance from the ends of the skids to the base of the item,  $L_1$  in figures 61, 62, and 63, or one-half the distance between legs, end frames, or columns,  $L_2$  in these figures, whichever is longer.

With closed-type bases, the  $L$  value is either one-half the distance between floorboards ( $L_2$  of figs. 61, 62, and 63) or the full distance ( $L_1$ ) from the end of the skid to the item base, whichever is longer.

The depths and widths of the members of the skid assembly may be determined either with tables 22, 23, and 24 or a formula.

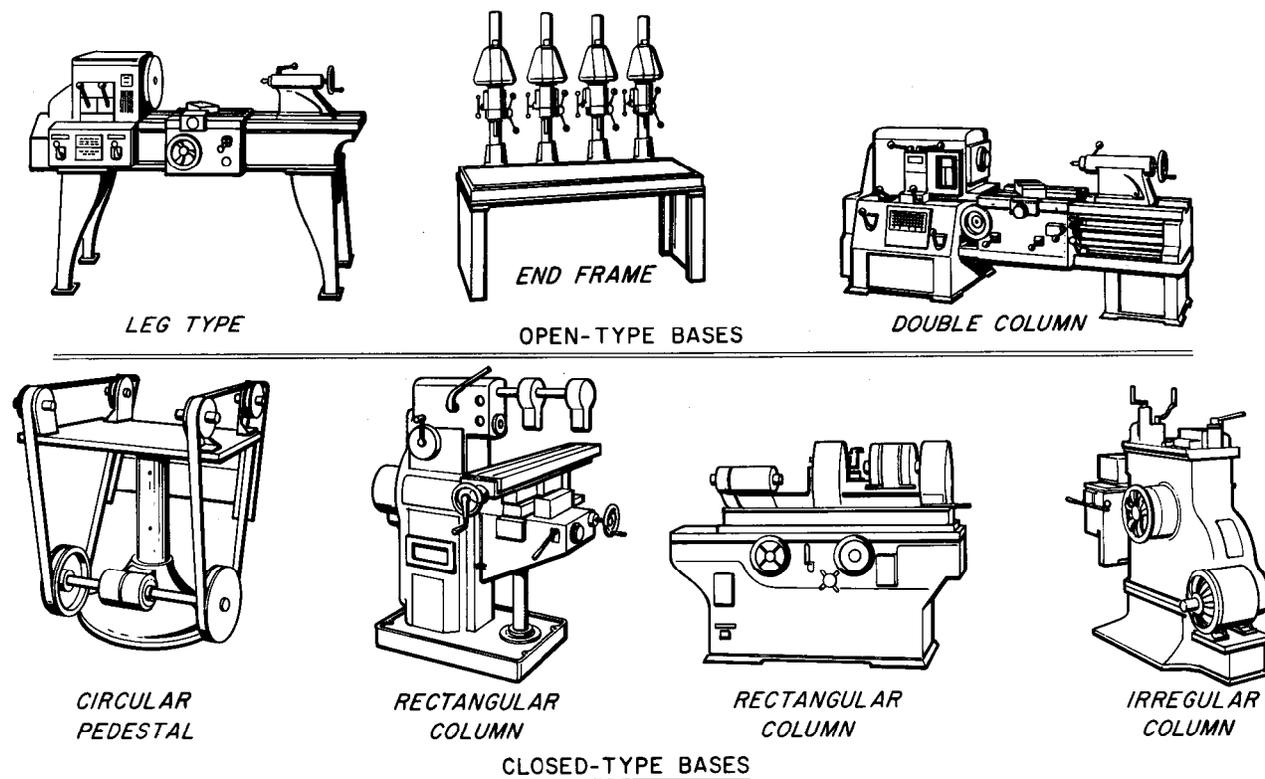
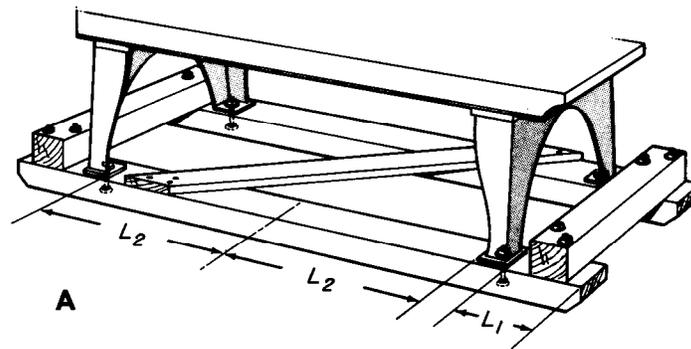
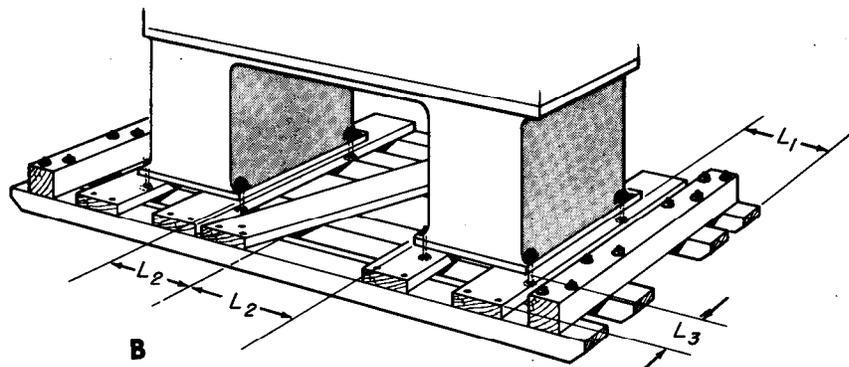

Figure 60.—Typical equipment with bases for which skid assemblies might be designed.



USE  $L_1$  OR  $L_2$ , WHICHEVER IS LARGER, IN DETERMINING SKID SIZE.  $L_3$  IS USED FOR FLOORBOARD SIZE.



M-119721

Figure 61.—Typical skid assemblies for equipment with open-type bases: A, For leg-type base of equipment without sidwise projections (floorboards not required unless more than two skids are used); B, for double-column-type base, including clearance for equipment with sidwise projections.

### Use of Formula

To determine the skid sizes by formula, either the depth or the total width of the skids may be assumed from the material available, and the formula then solved for the unknown. All skids in the same assembly should be the same size. The unknown, when groups II, III, or IV woods are used, should be determined from the formula:

$$WL = 33.3 BD^2$$

where  $W$  is total weight of article in pounds;  $L$  is span in feet;  $B$  is total width of skids in inches; and  $D$  is depth of skid in inches.

When group I woods are used, the unknown dimension should be determined for a load 20 percent greater than the weight of the article. For example, a 10,000-pound article would be calculated as 12,000 pounds.

### Use of Table

Table 22 gives skid widths and depths for values of  $WL$  from 1,000 to 140,000 foot-pounds. To determine the size of skid required, first find the proper  $WL$  value. Then follow across to the right to the column that lists the number of skids required. The skid size at the top of this column is satisfactory.

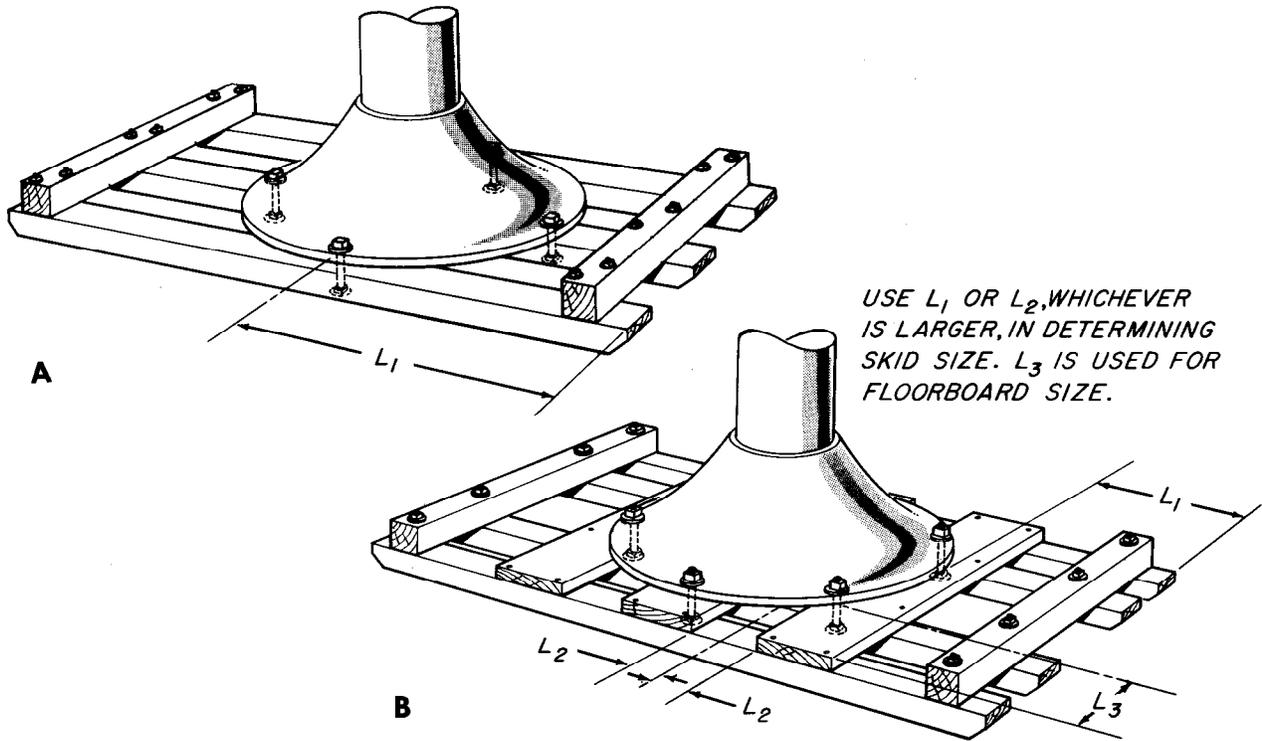

M-119722

Figure 62.—Typical skid assemblies for equipment with pedestal and similar closed-type bases: A, For equipment without sidewise projections; B, for equipment with sidewise projections.

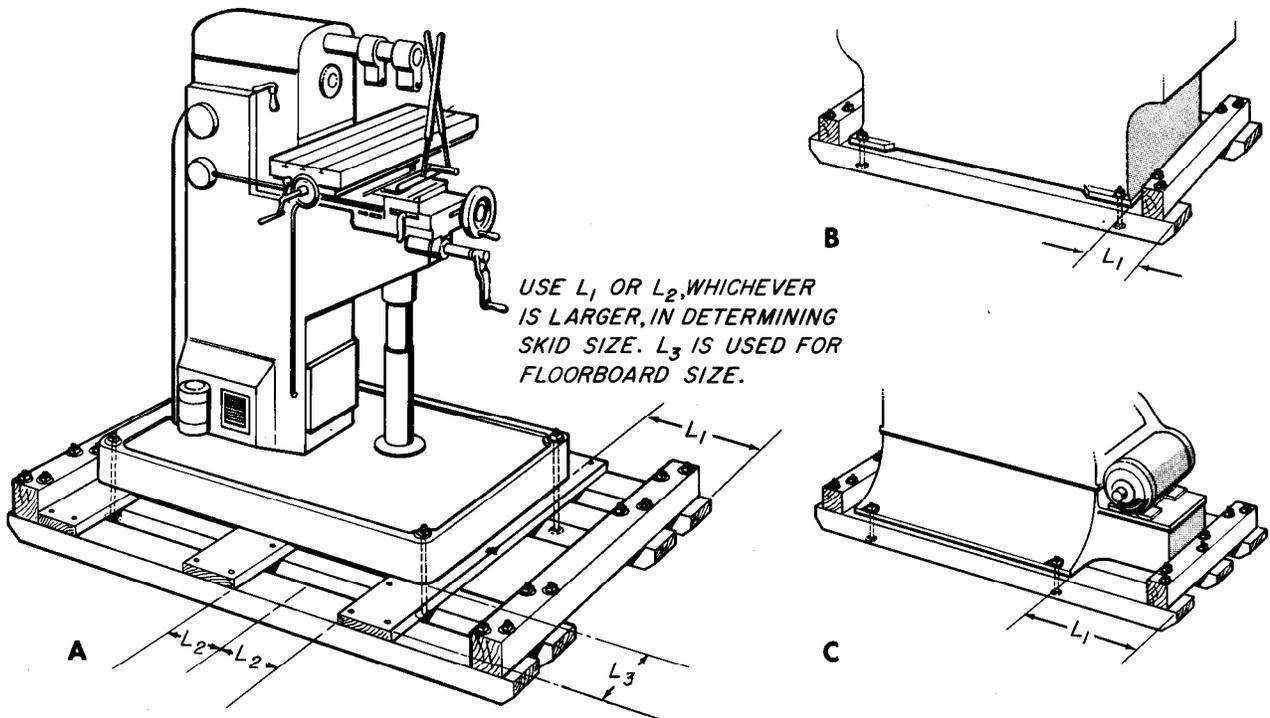

M-119908

Figure 63.—Typical skid assemblies for equipment with rectangular or irregular column closed-type bases: A, For rectangular base of equipment with sidewise projections; B, for rectangular base of equipment without sidewise projections; and C, for irregular column base of equipment without sidewise projections, showing additional skid.



TABLE 23.—Total width required for floorboards bearing loads

Load in pounds multiplied by span in feet ( <i>WL</i> )	Width required when floorboard depth is—						
	2 inches	3 inches	4 inches	6 inches	8 inches	10 inches	12 inches
<i>Foot-pounds</i>	<i>Inches</i>	<i>Inches</i>	<i>Inches</i>	<i>Inches</i>	<i>Inches</i>	<i>Inches</i>	<i>Inches</i>
1,000	8						
1,200	10						
1,400	10						
1,600	12						
1,800	14						
2,000	16	6					
2,500	18	8					
3,000	22	10					
3,500	26	12					
4,000	30	14					
4,500	34	15	8				
5,000	38	17	10				
6,000	45	20	11				
7,000	54	24	13				
8,000	60	26	15				
9,000	68	30	17				
10,000	76	36	19	9			
12,000	90	40	23	10			
14,000		46	26	12			
16,000		54	30	14			
18,000		60	34	15			
20,000		66	38	17			
25,000		84	47	21	12		
30,000		100	56	25	14		
35,000			66	30	16		
40,000			75	34	19	12	
45,000			84	38	21	14	
50,000			94	42	24	15	
60,000			112	50	28	18	
70,000				58	33	21	14
80,000				67	38	24	17
90,000				75	42	27	19
100,000				84	47	30	21
120,000				100	56	36	25
140,000				116	66	42	29

TABLE 24.—Sizes of diagonal braces and struts required for skid assemblies

Load	Depth and width required when length of diagonal or strut is—							
	5 feet	6 feet	7 feet	8 feet	9 feet	10 feet	11 feet	12 feet
<i>Pounds</i>	<i>Inches</i>	<i>Inches</i>	<i>Inches</i>	<i>Inches</i>	<i>Inches</i>	<i>Inches</i>	<i>Inches</i>	<i>Inches</i>
500 to 1,000	2 by 4	2 by 4	2 by 4	2 by 6	2 by 6	2 by 6	3 by 4 or 2 by 8	3 by 4 or 2 by 8
1,000 to 2,000	2 by 4	2 by 4	2 by 6	2 by 6	3 by 4 or 2 by 8	3 by 4 or 2 by 10	3 by 4 or 2 by 10	3 by 4
2,000 to 3,000	2 by 6	2 by 6	2 by 8	3 by 4 or 2 by 8	3 by 4 or 2 by 10	3 by 4	3 by 6	4 by 4 or 3 by 6
3,000 to 4,000	2 by 6	2 by 8	3 by 4 or 2 by 8	3 by 4 or 2 by 10	3 by 6	3 by 6	3 by 8	4 by 4 or 3 by 6
4,000 to 5,000	3 by 4 or 2 by 8	3 by 4 or 2 by 10	3 by 4 or 2 by 10	3 by 6	3 by 6	3 by 8	4 by 4 or 3 by 8	4 by 4 or 3 by 8

If the problem is to determine the number of skids to use when a certain size material is available, go to the right of the  $WL$  value to the appropriate skid-size column, which shows at this point the required number of skids.

## FLOORBOARD SIZES

Floorboards of uniform thickness should be used in any assembly where all of the skids do not contact the load, as shown by some of the skid assemblies in figures 61, 62, and 63. Requirements for floorboards of groups II, III, or IV woods are determined from the same formula as are unknown skid dimensions:

$$WL = 33.3 BD^2$$

The difference is that the floorboard span  $L(L_3$  in figs. 61, 62, and 63) is the distance in feet from the outer edge of the skid to the flange edge of the article.

Table 23 gives the floorboard requirements for values of  $WL$  from 1,000 to 140,000 foot-pounds. When group I woods are used, the weight of the article is increased 20 percent before calculations are made. The full width, as determined from the formula or table, should be placed under the base of the item. No floorboards should be less than 2 by 4 inches.

For items with open-type bases, at least one floorboard of a skid assembly with more than two skids should be under each pair of legs or under each frame or column (fig. 61). The flooring should be arranged to support all bottom edges, cross walls, and ribs of the item that parallel the floorboards. When more than one floorboard is required for support, the spacings of the boards are governed by the requirements for strength. The fastening bolts should pass through both skids and floorboards.

When floorboards are required for closed-type bases (figs. 62 and 63) at least three floorboards should be used. The anchor bolts should pass through both skids and floorboards.

There can be no absolute standards or rules for designing crates. For example, while a crate top may be designed for loads up to 200 pounds per square foot, it might be subjected to a load of twice this limit under difficult storage conditions.

## DIAGONAL BRACING

Skid assemblies for items with open-type bases usually require one or more diagonal braces (fig. 61). The angle of the diagonal with the skids should be as near  $45^\circ$  as possible but not less than  $30^\circ$  or more than  $60^\circ$ . Diagonals may be fastened to the upper side of the skids or to the under side of headers and floorboards. Adjoining diagonals should slope in opposite directions with a strut between them spanning the assembly. A strut is not ordinarily needed when the diagonal bracing is crossed by floorboards or by part of the item's base. The sizes of these diagonals and struts are found in table 24.

## ASSEMBLY

The fastenings used in skid assemblies are nails, lag screws, and bolts. Carriage or step bolts are used to assemble the skids to the end headers. At each skid contact one bolt should be used when the header is 5 inches or less in width, and two bolts when the header is wider than 5 inches. When the header is less than 3 inches deep, use bolts  $\frac{3}{8}$  inch in diameter; when 3 to 5 inches deep,  $\frac{1}{2}$ -inch bolts; and when over 5 inches deep,  $\frac{5}{8}$ -inch bolts. Boltheads should be flush with the under sides of the skids.

In fastening the floorboards, diagonals, and struts to the skids, either bolts or nails may be used, depending on the thickness of the members. When 2-inch members are fastened to a 1-inch-deep skids, use two twelvepenny coated or etched nails for material 4 inches wide and three nails for members wider than 4 inches. When the diagonals, struts, or floorboards are 2 inches deep and the skids are deeper than 2 inches, use sixteenpenny nails. When all members are over 2 inches deep, use carriage or step bolts in the same manner as outlined for the skid-header connections.

The item should be fastened securely to the skid assembly with bolts, U-bolts, metal brackets, or similar fastenings. Lag screws are not recommended for this purpose.

It is good practice to put bolts through the ends of large skids to prevent them from splitting during shipment and handling. These bolts are placed above the center of the skid and about  $2\frac{1}{2}$  inches from the end.

## TESTING CRATES

However, because of the safety factors included in the design, short-time application of such static loads does not ordinarily cause failure. Nevertheless, it is reasonable to assume that some crates will be subjected to loads that will cause

failure. But designing all crates to resist every stress is not economical. Thus, both design standards and tests to check them should be based on conditions to which the majority of crates are subjected.

The design of a crate may vary greatly for any item, depending on the means of transportation and the destination. Domestic shipment of most items will not ordinarily involve as great or as many hazards as shipment overseas. Consequently, in domestic crates frame members may be smaller and fastenings less rigid. But some means should be used to evaluate a newly designed pilot crate, whether for domestic or export shipment. Tests should simulate actual shipping, handling, and storage conditions as closely as possible in order to determine the suitability of construction.

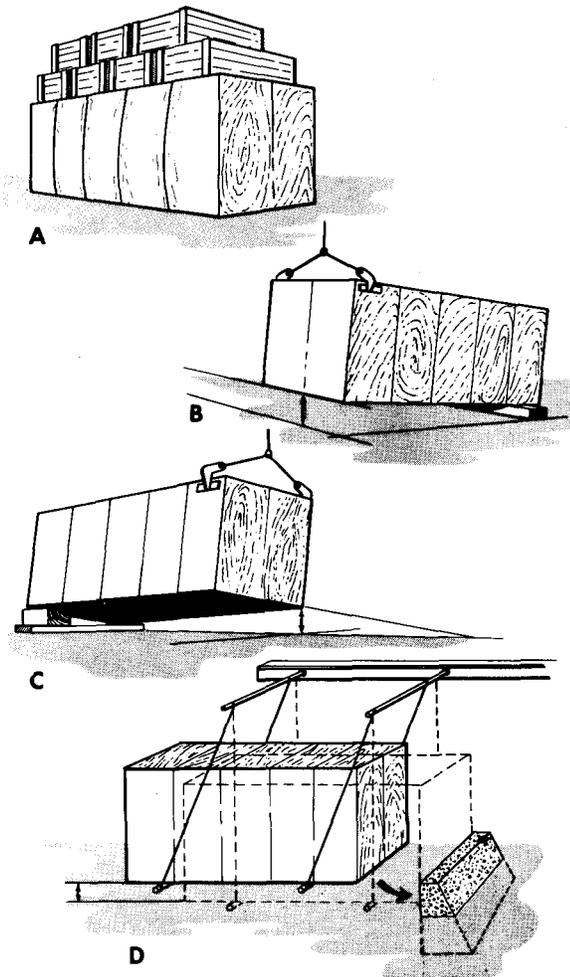

M-119683

Figure 64.—Rough-handling tests for crates: A, superimposed load; B, edgewise drop; C, cornerwise drop; and D, pendulum impact.

The development of crate design criteria at the Forest Products Laboratory led to a series of tests designed to include those hazards ordinarily imposed on crates during storage, handling, and shipping (fig. 64). These tests were used on scores of containers of all sizes and types, from small open to large sheathed crates.

The following sections outline the various test methods that might be used by the designer to improve crates or to verify construction details. However, with a crate design based on engineering principles, a limited crate testing program may be satisfactory. A good indication of the crate's adequacy could be gained from superimposed load, edgewise-drop and cornerwise-drop tests.

### SUPERIMPOSED-LOAD TESTS

Superimposed loading may occur during storage and shipping. When items placed on the top of a crate are smaller in area than the crate top, the load must be carried by joists or the top framing system, which transfer the stresses to the sides and ends. However, the load of an equal-size container is carried by the crate sides and ends. Little, if any, is supported by the joist system. This may also be true when dunnage is used to transfer loads to the sides.

The tops of sheathed crates are ordinarily designed to carry superimposed loads, but tops of open crates are seldom constructed to carry more than the weight of a man. Inasmuch as most open crates are used for domestic shipment, there is little need for costly joist systems adequate to support loads that ordinarily are not placed on top without dunnage.

It is suggested that sheathed crates be subjected to top load tests that place stresses on the joist system and on the sides and ends. Open crates may be tested by methods that place the loads only on the sides and ends.

### Top Load Tests For Joists and Framing

Top joists are often designed for loads of 50 to 100 pounds per square foot. Under most conditions a load of 50 pounds per square foot may be considered as normal, and 100 pounds per square foot as moderate.

One of the simpler methods of applying loads to top joist systems without special equipment is by using sand. If the crate top only is to be tested, it may be convenient to place the fabricated top, without the sides and ends, on supports raised a foot or more off the ground. The supports should be positioned so that the span is the same as in the assembled crate. A framework of boards or plywood is then made around the perimeter of the top, and sand is poured uniformly over the enclosed area (fig. 65). It is desirable to use crosstie wires and a membrane such as a plastic

sheet to prevent the sand from escaping and the framework from bulging. Sand averages about 100 pounds per cubic foot, so a 6-inch layer would apply a uniform load of 50 pounds per square foot; a 12-inch layer, 100 pounds per square foot. A sample weighing should be made to determine the exact weight per cubic foot of the sand used. To increase the test load, loaded boxes may also be added (fig. 65).

Deflection of the joists may be measured by placing a nail at each end of the joist and stretching a fine wire or string between. By measuring the distance from the wire to the bottom of the joist with and without load, the net deflection can be calculated. Various designs can be compared by determining the deflection of their joists. The ultimate strength of the top framing and the joists can be found by adding known increments of load to the top until it fails.

Testing machines can also be used to test the tops (fig. 66), but are usually restricted to testing narrow panels. Maximum loads can be easily determined in this type of machine.

### Top Load Tests for Sides and Ends

The sides of a crate may be designed to support top loads of 200 to 400 pounds per square foot. This is necessary because crates in storage are often stacked four or more high. When heavy items are crated, this means tremendous loads are placed on the lower crate. The tables of sizes

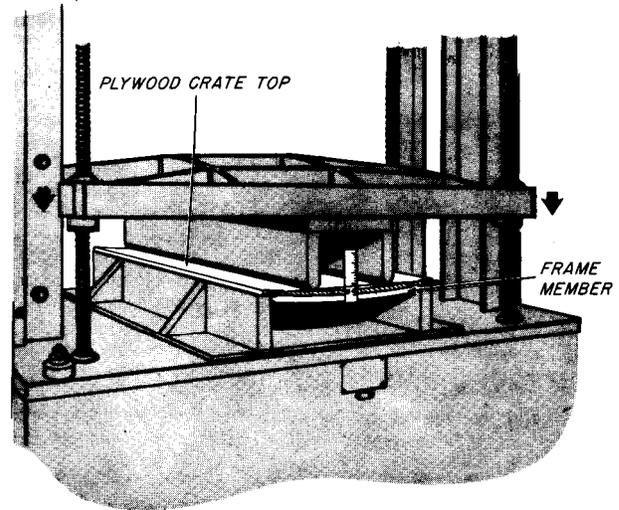

M-119685

Figure 66.—Testing a narrow crate top in a universal testing machine. Plywood without a frame is often sufficiently strong to carry loads over short spans.

for the members of sheathed crates, listed in Appendix I, cover sides designed to resist top loads of 200 pounds per square foot in crates used for items weighing through 10,000 pounds, and 400 pounds per square foot in crates designed for loads over 10,000 pounds.

To test crates in a manner similar to actual conditions, it is necessary to place the loads so

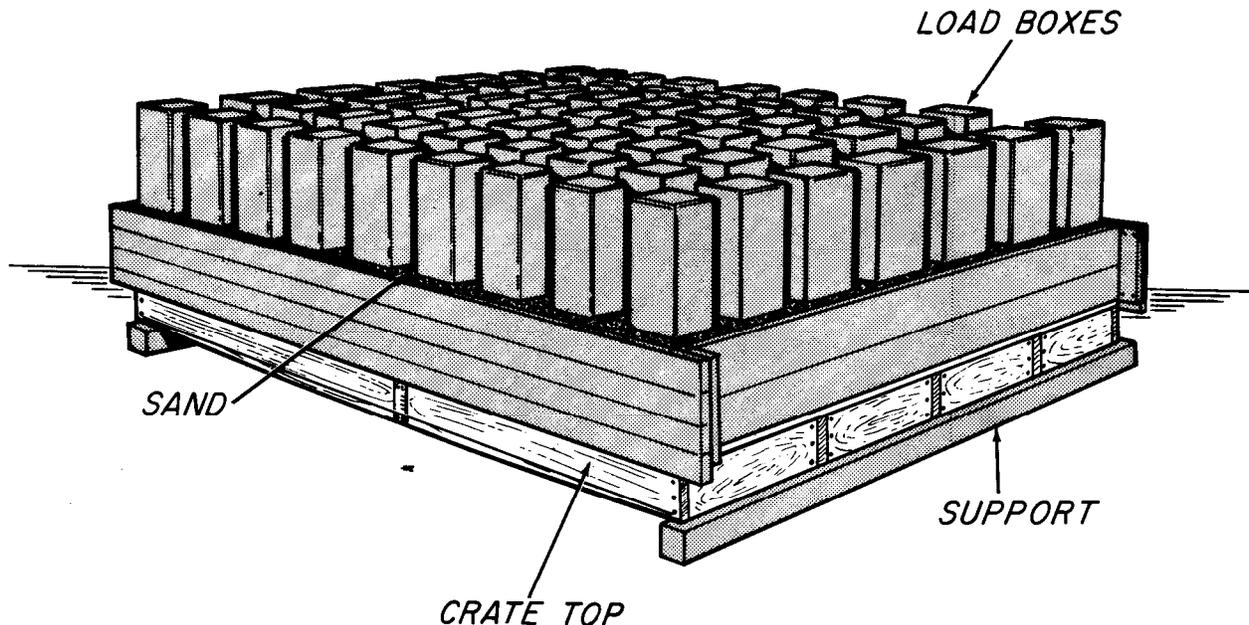

M-119684

Figure 65.—Testing the framing of a crate top. Loads consist of sand placed to a uniform depth over the surface and the addition of load boxes.

that they are carried by the sides or by sides and ends. The use of another crate of the same size would accomplish this, but with large crates this involves a serious handling problem. Perhaps a better solution is the use of dunnage, 4- to 6-inch-thick timbers, placed on top of the crate across its width. After the dunnage has been placed, load boxes are placed uniformly over the surface by means of a crane or forklift truck. This type of loading will place most of the stresses on the side panels. Figure 64, A shows a sheathed crate with a load of large boxes being used to test the crate sides. The boxes are long enough to span the width of the crate. Sturdily constructed boxes filled with sand and securely strapped have served very well in this type of test. The vertical deflection of the crate sides is measured when the load is in place. This test is seldom continued to failure unless extreme caution is practiced, especially if the crates are large. For smaller crates, ultimate superimposed loads can be found with a large testing machine. Figure 67 shows a high, narrow crate being tested in such a machine.

### HANDLING TESTS

Tests have been developed to simulate actual crate handling by sling, grabhook, and forklift. While every crate is not necessarily handled by all of these methods, crates designed for overseas shipment should be capable of withstanding all types of handling. This is especially true of sheathed crates, where both grabhook and sling handling might be used. Much of the handling of crates is with forklift trucks, and ordinarily all crates allow the entry of forklift fingers from both the sides and ends, through spaces between the rubbing strips. By allowing side spaces at the ends as well as at the center of balance, end sling handling is also possible.

Crates to be tested should contain loads at least equal to the design loads. The load may consist of heavy, nailed wood boxes filled with sand and strapped securely to load-bearing floorboards (fig. 68).

### Sling Handling

All crates used for shipping, except perhaps small, light crates, should include some provision for being lifted with slings. The skids of large crates are heavy enough to allow a notch at each end for the sling. For crates with rubbing strips, an end space is left at each end of the crate. Two kinds of slings are ordinarily used to lift and handle crates aboard ships and in dock areas. One uses one or more spreader bars to prevent the crate from being crushed when it is lifted; the other does not.

If hoisting cables are the only means of lifting and handling a crate and no sling areas have been

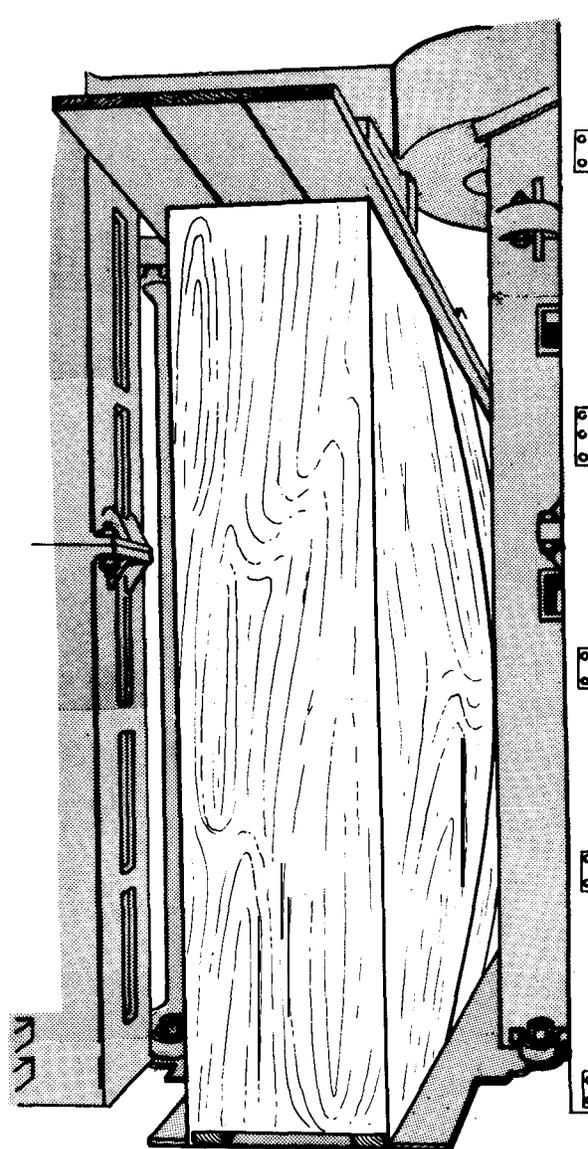

M-119686

Figure 67.—Top loading a high, narrow crate. Mechanical testing machine is applying a top load of 950 pounds per square foot.

incorporated into the base design, the cables are often placed around the ends and sides of the crate. This tends to crush the ends of the crate. When the cable-only method is used with a short cable, crushing stresses are placed on base, sides, and top. The top is especially vulnerable to crushing, and this is a severe test. Long cables cause less crushing than short cables. Reinforcing joists, each positioned where a cable contacts the top panel, will resist these crushing forces. Figure 69 shows a crate being unloaded with long cables.

The use of large hoisting equipment with a cable rig is the simplest method of testing a crate

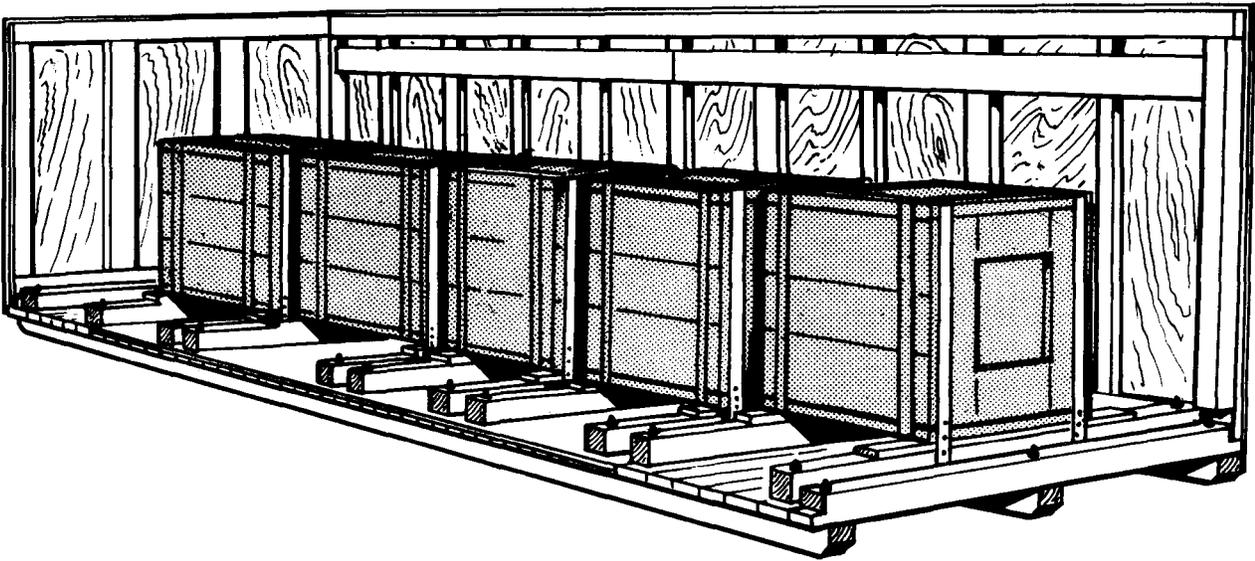

M-119687

Figure 68.—Typical load for handling tests. Large boxes filled with sand are strapped to load-bearing floorboards.

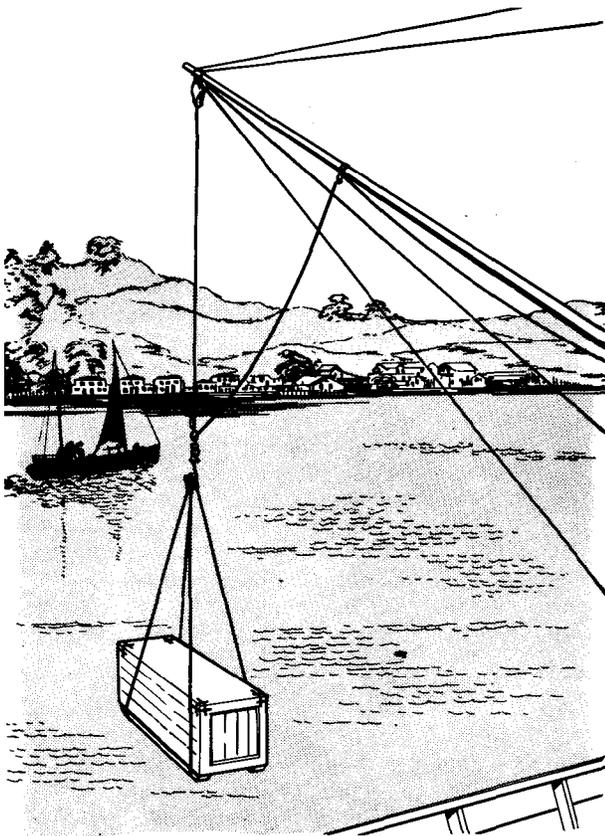

M-119688

Figure 69.—Unloading a crate from ship by means of long cables.

with slings. Longitudinal deflection should be determined by measurements made before and during the lift. This deflection should be small; the allowable magnitude varies with the crate length. When lifting equipment is not available, an A-frame support may be used. The crate may be jacked up into position and then lowered until supported by the slings. Figure 70 shows a device of this type with the slings looped around the crate ends. However, for average conditions, slings placed under each set of skids at the ends should be satisfactory for this lifting test.

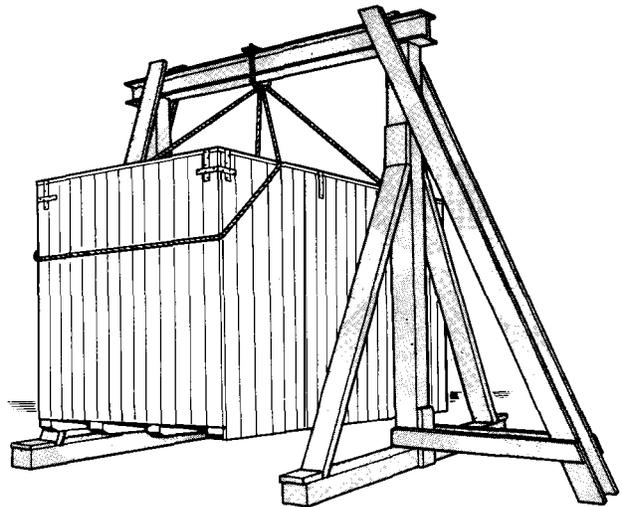

M-119689

Figure 70.—Loaded test crate supported by slings looped around the ends of the crate.

## Grabhook Handling

Grabhooks are sometimes employed in handling crates of small and medium size. Their use should ordinarily be discouraged because of the eventual destruction of the crate sheathing at the lifting points. Crates with a reinforcing joist in the top panel at the center of balance can resist grabhook handling.

A crane or mechanical lifting device with cables is perhaps most convenient for testing with grabhooks. However, the slings and k-frame described in the previous section may be used also. The loaded test crate should be lifted and supported with one grabhook located on each side at the center of balance (fig. 71).

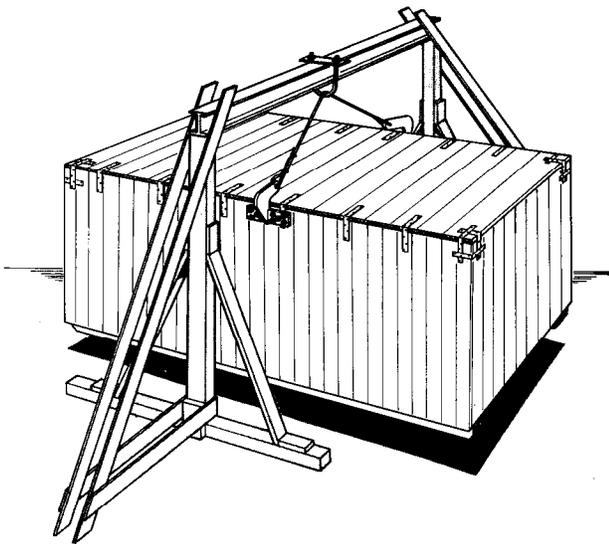

M-119690

Figure 71.—Test crate supported by a single set of grabhooks.

One simple way to measure longitudinal deflection is to drive a nail near each end on one side. A fishline or a fine wire is then stretched between the nails, with a rubberband at one end to keep the wire taut. Make a mark at the center of the crate in line with the level measuring wire. When the crate is lifted, make a second mark; the distance between the two is the bending deflection caused by the weight of the crate and the contents. The allowable deflection depends on the length of the crate and should be minor. Too great a deflection indicates poor design or construction.

## Forklift Handling

Handling with a forklift truck is becoming more common even for very large crates. Crates of light or medium weight are usually lifted from the sides by forklift trucks, and provisions are made in crate design for this. Large, heavy crates

are often moved with two forklift trucks by placing their forklift fingers under each end of the base. A forklift from the side is similar to a grabhook lift at the center of balance. Two forklifts from the ends is similar to lifting by end slings. Lifting the loaded test crate from either side places stresses on the inner and outer skids and indicates the resistance of the skids and other members to this type of lifting. The bending stresses on the inner skids are transferred to the load-bearing floorboards or other crossmembers. Lifting from the ends with forklift trucks causes bending of the end headers or floorboards.

Any deficiencies brought out by the handling tests should be corrected by design changes, including, for example, using heavier or properly located top reinforcing joists, adding filler skids to accommodate forklift fingers from the sides, and increasing the size or spacing of end headers in the base. Tests on pilot crates will bring out any weaknesses that need to be corrected in order to minimize damages to crates.

## DROP AND IMPACT TESTS

Crates handled with a variety of equipment and under many conditions are often subjected to accidental drops. A lifting device may be released too fast, resulting in a corner impact, or a crate may skid off a truck, impacting one edge. An end impact may result when a swinging crate is let down with slings. All crates are not subjected to these hazards, but it is important that the crate design include sufficient strength to resist them. Drop tests of some type should be incorporated in the testing program, because impacts caused by drops are severe and can result in member damage and fastening failures. The three general tests that simulate impacts to crates and are ordinarily used to test crates are (1) the edgewise-drop, (2) the cornerwise-drop, and (3) the pendulum-impact tests (fig. 64).

Drop tests are reasonably simple to conduct and require only a minimum amount of equipment. As in the handling tests, the test crate should contain a load, similar in weight to the item for which the crate is designed. Nailed wood boxes filled with sand are satisfactory. After the test loads are anchored inside, the crate is completely assembled with the correct number, size, and spacing of fasteners for the design.

### Edgewise-Drop Test

The edgewise-drop test is conducted by first placing one end of the base of the test crate on a 5- or 6-inch-square timber sill. The opposite end is then raised to a predetermined height and allowed to fall freely to a level concrete floor or slab. The end of the crate may be raised by a hoist with a quick-release device attached that

can be triggered from a safe distance (fig. 64, *B*). Or the raised end of the crate may be placed on a wood block of the proper length with a chain or cable attached. A truck or other mechanical device is used to pull out the block quickly, permitting the end of the crate to drop to the concrete slab.

A series of drop heights, similar to those used in testing programs at the Forest Products Laboratory, is shown in table 25. The height of drop is selected that will meet the requirements for both the gross weight and dimensions of the crate. For example, a crate that weighs less than 600 pounds but has a dimension over 72 inches will be dropped from 24 inches if for overseas shipment and 18 inches if for domestic.

TABLE 25.—*Drop heights for edgewise and cornerwise drop tests of crates of various weights and lengths*

Gross weight (crate and contents)  (pounds)	Height of drop for lengths of—			
	Up to 72 inches		Over 72 inches	
	Over- seas	Do- mestic	Over- seas	Do- mestic
	<i>Inches</i>	<i>Inches</i>	<i>Inches</i>	<i>Inches</i>
Up to 600.....	36	27	24	18
600 through 3,000..	24	18	24	18
Over 3,000.....	12	9	12	9

The test crate should be dropped on each end. Longitudinal deflection measurements should be made before and after the drops to determine the amount of residual deflection. Careful notes should be made of broken members, splits, and nailpulls. The edgewise-drop test not only places bending stresses on the crate as a whole, but also is a positive test for side-to-base fastenings and for the load-bearing floorboards. The data assembled from the tests will guide the designer in improving the crate.

### Cornerwise-Drop Test

The cornerwise-drop causes severe racking stresses in all panels of the crate, impact of the corner, and bending stresses similar to those in edgewise drops.

A block is placed on one end of the sill so that one supported corner is 5 to 6 inches higher than the other supported corner. The opposite end is then raised to a height designated in table 25 and allowed to fall freely (fig. 64, *C*). The corner diagonally opposite the corner block strikes the concrete slab first. As in the edgewise-drop test the crate should be dropped on each end, and the

deflection measurements and other data on failures and reactions of parts of the crate should be compiled.

### Pendulum-Impact Test

The pendulum-impact test is primarily intended as a test of the blocking and bracing of the item in the crate. It also stresses the bolts used to fasten the load-bearing floorboards to the skids. It simulates not only accidental impacts of a crate swinging on slings, but also the humping that occurs in the switching of railway cars.

The pendulum-impact test requires some type of suspended platform or sling to hold the crate. This platform is suspended with at least four parallel cables or chains about 20 to 24 feet in length (fig. 64, *D*). When suspended the platform should be parallel to the floor with a 3- or 4-inch clearance. The backstop may be concrete or a large timber rigidly secured. The crate is placed so that it rests lightly against the backstop when the platform is freely suspended. The platform is pulled back from the backstop until the crate is raised 9 inches. Then it is released and allowed to swing freely against the backstop. Each end is tested with one impact in this manner. The freight car speed that gives an impact equivalent to the 9-inch pendulum test is about 7 miles per hour.

A variation of the described test would be to conduct it with a load or another crate on top of the test crate. This would create severe racking stresses on the sides and on the side-to-end nailing and other fastenings.

The notes, measurements, and other data gathered during the series of crate tests, together with general observations, are usually sufficient to determine the adequacy of the design. When necessary, details of the design may be changed, incorporated into the test crate, and retested. It may be necessary to repeat only one or two phases of the test schedule. For example, if the fastenings of the sides to the base failed during the edgewise-drop tests, the spacing and location would be changed or a different type of fastener used. The changed test crate would then be subjected only to the edgewise-drop test if the other tests had been passed.

These tests were designed to reveal any major weakness in the crate parts or in the fabrication and assembly methods. Other tests may be used, but each should be developed to simulate some phase of handling or storage that creates special hazards not covered here. Of course, not all conditions a crate might encounter can be anticipated, and it would not be economical to design a crate to resist all real and theoretical hazards. However, a good testing program used in the development of new crate designs will more than pay for itself.

## APPENDIX I. PANEL MEMBER SIZES

Panel member sizes for crates of various dimensions, designed to carry loads through 30,000 pounds, are given in tables 26 through 35.

TABLE 26.—Panel member sizes for crates<sup>1</sup> designed for a net load of 1,000 pounds  
4-FOOT-WIDE CRATE

Length	Member	Crate height					
		2 feet	4 feet	6 feet	8 feet	10 feet	12 feet
<i>Ft.</i>		<i>In.</i>	<i>In.</i>	<i>In.</i>	<i>In.</i>	<i>In.</i>	<i>In.</i>
6	Upper frame.....	1 by 4	1 by 4	1 by 4	1 by 4	1 by 4	1 by 4
	Lower frame.....						
	Strut.....						
	Diagonal.....						
8	Upper frame.....	1 by 4	1 by 4	1 by 4	1 by 4	1 by 4	1 by 4
	Lower frame.....						
	Strut.....						
	Diagonal.....						
10	Upper frame.....	1 by 4	1 by 4	1 by 4	1 by 4	1 by 4	1 by 4
	Lower frame.....						
	Strut.....						
	Diagonal.....						
12	Upper frame.....	1 by 4	1 by 4	1 by 4	1 by 4	1 by 4	1 by 4
	Lower frame.....						
	Strut.....						
	Diagonal.....						
16	Upper frame.....	1 by 4	1 by 4	1 by 4	1 by 4	1 by 4	1 by 4
	Lower frame.....						
	Strut.....						
	Diagonal.....						
20	Upper frame.....	1 by 4	1 by 4	1 by 4	1 by 4	1 by 4	1 by 4
	Lower frame.....						
	Strut.....						
	Diagonal.....						
24	Upper frame.....	(2)	1 by 4	1 by 4	1 by 4	1 by 4	1 by 4
	Lower frame.....	(2)					
	Strut.....	(2)					
	Diagonal.....	(2)					
28	Upper frame.....	(2)	1 by 4	1 by 4	1 by 4	1 by 4	1 by 4
	Lower frame.....	(2)					
	Strut.....	(2)					
	Diagonal.....	(2)					
32	Upper frame.....	(2)	1 by 4	1 by 4	1 by 4	1 by 4	1 by 4
	Lower frame.....	(2)					
	Strut.....	(2)					
	Diagonal.....	(2)					
36	Upper frame.....	(2)	1 by 4	1 by 4	1 by 4	1 by 4	1 by 4
	Lower frame.....	(2)					
	Strut.....	(2)					
	Diagonal.....	(2)					
40	Upper frame.....	(2)	1 by 4	1 by 4	1 by 4	1 by 4	1 by 4
	Lower frame.....	(2)					
	Strut.....	(2)					
	Diagonal.....	(2)					
44	Upper frame.....	(2)	1 by 4	1 by 4	1 by 4	1 by 4	1 by 4
	Lower frame.....	(2)					
	Strut.....	(2)					
	Diagonal.....	(2)					
48	Upper frame.....	(2)	1 by 4	1 by 4	1 by 4	1 by 4	1 by 4
	Lower frame.....	(2)					
	Strut.....	(2)					
	Diagonal.....	(2)					

See footnotes at end of table.

TABLE 26.—Panel member sizes for crates<sup>1</sup> designed for a net load of 1,000 pounds—Continued  
6-FOOT-WIDE CRATE

Length	Member	Crate height					
		2 feet	4 feet	6 feet	8 feet	10 feet	<sup>a</sup> 12 feet
<i>Ft.</i>		<i>In.</i>	<i>In.</i>	<i>In.</i>	<i>In.</i>	<i>In.</i>	<i>In.</i>
6	Upper frame.....	1 by 4	1 by 4	1 by 4	1 by 4	1 by 4	1 by 4
	Lower frame.....						
	Strut.....						
	Diagonal.....						
8	Upper frame.....	1 by 4	1 by 4	1 by 4	1 by 4	1 by 4	1 by 4
	Lower frame.....						
	Strut.....						
	Diagonal.....						
10	Upper frame.....	1 by 4	1 by 4	1 by 4	1 by 4	1 by 4	1 by 4
	Lower frame.....						
	Strut.....						
	Diagonal.....						
12	Upper frame.....	1 by 4	1 by 4	1 by 4	1 by 4	1 by 4	1 by 4
	Lower frame.....						
	Strut.....						
	Diagonal.....						
16	Upper frame.....	1 by 4	1 by 4	1 by 4	1 by 4	1 by 4	1 by 4
	Lower frame.....						
	Strut.....						
	Diagonal.....						
20	Upper frame.....	1 by 4	1 by 4	1 by 4	1 by 4	1 by 4	1 by 4
	Lower frame.....						
	Strut.....						
	Diagonal.....						
24	Upper frame.....	( <sup>2</sup> )	1 by 4	1 by 4	1 by 4	1 by 4	1 by 4
	Lower frame.....	( <sup>2</sup> )					
	Strut.....	( <sup>2</sup> ) 1 by 4					
	Diagonal.....	( <sup>2</sup> ) 1 by 4					
28	Upper frame.....	( <sup>2</sup> )	1 by 4	1 by 4	1 by 4	1 by 4	1 by 4
	Lower frame.....	( <sup>2</sup> )					
	Strut.....	( <sup>2</sup> ) 1 by 4					
	Diagonal.....	( <sup>2</sup> ) 1 by 4					
32	Upper frame.....	( <sup>2</sup> )	1 by 4	1 by 4	1 by 4	1 by 4	1 by 4
	Lower frame.....	( <sup>2</sup> )					
	Strut.....	( <sup>2</sup> ) 1 by 4					
	Diagonal.....	( <sup>2</sup> ) 1 by 4					
36	Upper frame.....	( <sup>2</sup> )	1 by 4	1 by 4	1 by 4	1 by 4	1 by 4
	Lower frame.....	( <sup>2</sup> )					
	Strut.....	( <sup>2</sup> ) 1 by 6					
	Diagonal.....	( <sup>2</sup> ) 1 by 4					
40	Upper frame.....	( <sup>2</sup> )	1 by 4	1 by 4	1 by 6	1 by 4	1 by 4
	Lower frame.....	( <sup>2</sup> ) 1 by 6					
	Strut.....	( <sup>2</sup> ) 1 by 6					
	Diagonal.....	( <sup>2</sup> ) 1 by 4					
44	Upper frame.....	( <sup>2</sup> )	1 by 6	1 by 4	2 by 4	1 by 4	2 by 4
	Lower frame.....	( <sup>2</sup> ) 1 by 4					
	Strut.....	( <sup>2</sup> ) 1 by 6					
	Diagonal.....	( <sup>2</sup> ) 1 by 4					
48	Upper frame.....	( <sup>2</sup> )	1 by 6	1 by 6	2 by 4	1 by 6	2 by 4
	Lower frame.....	( <sup>2</sup> ) 1 by 4					
	Strut.....	( <sup>2</sup> ) 1 by 6					
	Diagonal.....	( <sup>2</sup> ) 1 by 4					

See footnotes at end of table.

TABLE 26.—Panel member sizes for crates<sup>1</sup> designed for a net load of 1,000 pounds—Continued  
8-FOOT-WIDE CRATE

Length	Member	Crate height					
		2 feet	4 feet	6 feet	8 feet	10 feet	12 feet
<i>Ft.</i>		<i>In.</i>	<i>In.</i>	<i>In.</i>	<i>In.</i>	<i>In.</i>	<i>In.</i>
6	Upper frame.....	1 by 4	1 by 4	1 by 4	1 by 4	1 by 4	2 by 4
	Lower frame.....						2 by 4
	Strut.....						2 by 4
	Diagonal.....						1 by 4
8	Upper frame.....	1 by 4	1 by 4	1 by 4	1 by 4	1 by 4	2 by 4
	Lower frame.....						2 by 4
	Strut.....						2 by 4
	Diagonal.....						1 by 4
10	Upper frame.....	1 by 4	1 by 4	1 by 4	1 by 4	1 by 4	2 by 4
	Lower frame.....						2 by 4
	Strut.....						2 by 4
	Diagonal.....						1 by 4
12	Upper frame.....	1 by 4	1 by 4	1 by 4	1 by 4	1 by 4	2 by 4
	Lower frame.....						2 by 4
	Strut.....						2 by 4
	Diagonal.....						1 by 4
16	Upper frame.....	1 by 4	1 by 4	1 by 4	1 by 4	1 by 4	2 by 4
	Lower frame.....						2 by 4
	Strut.....						2 by 4
	Diagonal.....						1 by 4
20	Upper frame.....	1 by 4	1 by 4	1 by 4	1 by 4	1 by 4	2 by 4
	Lower frame.....						2 by 4
	Strut.....						2 by 4
	Diagonal.....						1 by 4
24	Upper frame.....	(2)	1 by 4	1 by 4	1 by 4	1 by 4	2 by 4
	Lower frame.....	(2)	1 by 4				
	Strut.....	(2)	1 by 6				
	Diagonal.....	(2)	1 by 4				
28	Upper frame.....	(2)	1 by 4	1 by 4	1 by 4	1 by 4	2 by 4
	Lower frame.....	(2)	1 by 4				
	Strut.....	(2)	1 by 6				
	Diagonal.....	(2)	1 by 4				
32	Upper frame.....	(2)	1 by 4	1 by 4	2 by 4	1 by 4	2 by 4
	Lower frame.....	(2)	1 by 4				
	Strut.....	(2)	1 by 6				
	Diagonal.....	(2)	1 by 4				
36	Upper frame.....	(2)	1 by 6	1 by 4	2 by 4	1 by 4	2 by 4
	Lower frame.....	(2)	1 by 4				
	Strut.....	(2)	1 by 6				
	Diagonal.....	(2)	1 by 4				
40	Upper frame.....	(2)	1 by 6	1 by 4	2 by 4	1 by 4	2 by 4
	Lower frame.....	(2)	1 by 4				
	Strut.....	(2)	1 by 6				
	Diagonal.....	(2)	1 by 4				
44	Upper frame.....	(2)	1 by 6	1 by 4	2 by 4	1 by 4	2 by 4
	Lower frame.....	(2)	1 by 4				
	Strut.....	(2)	1 by 6				
	Diagonal.....	(2)	1 by 4				
48	Upper frame.....	(2)	2 by 4	1 by 4	2 by 4	1 by 4	2 by 4
	Lower frame.....	(2)	1 by 4				
	Strut.....	(2)	1 by 6				
	Diagonal.....	(2)	1 by 4				

See footnotes at end of table.

TABLE 26.—Panel member sizes for crates<sup>1</sup> designed for a net load of 1,000 pounds—Continued  
10-FOOT-WIDE CRATE

Length <i>Ft.</i>	Member	Crate height					
		2 feet	4 feet	6 feet	8 feet	10 feet	12 feet
		<i>In.</i>	<i>In.</i>	<i>In.</i>	<i>In.</i>	<i>In.</i>	<i>In.</i>
6	Upper frame.....	1 by 4	1 by 4	1 by 4	1 by 4	2 by 4	2 by 4
	Lower frame.....						
	Strut.....						
	Diagonal.....						
8	Upper frame.....	1 by 4	1 by 4	1 by 4	1 by 4	2 by 4	2 by 4
	Lower frame.....						
	Strut.....						
	Diagonal.....						
10	Upper frame.....	1 by 4	1 by 4	1 by 4	1 by 4	2 by 4	2 by 4
	Lower frame.....						
	Strut.....						
	Diagonal.....						
12	Upper frame.....	1 by 4	1 by 4	1 by 4	1 by 4	2 by 4	2 by 4
	Lower frame.....						
	Strut.....						
	Diagonal.....						
16	Upper frame.....	1 by 4	1 by 4	1 by 4	1 by 4	2 by 4	2 by 4
	Lower frame.....						
	Strut.....						
	Diagonal.....						
20	Upper frame.....	1 by 4	1 by 4	1 by 4	1 by 4	2 by 4	2 by 4
	Lower frame.....						
	Strut.....						
	Diagonal.....						
24	Upper frame.....	(2)	1 by 4	1 by 4	1 by 4	2 by 4	2 by 4
	Lower frame.....						
	Strut.....						
	Diagonal.....						
28	Upper frame.....	(2)	1 by 4	1 by 4	1 by 4	2 by 4	2 by 4
	Lower frame.....						
	Strut.....						
	Diagonal.....						
32	Upper frame.....	(2)	1 by 4	1 by 4	1 by 4	2 by 4	2 by 4
	Lower frame.....						
	Strut.....						
	Diagonal.....						
36	Upper frame.....	(2)	1 by 4	1 by 4	1 by 4	2 by 4	2 by 4
	Lower frame.....						
	Strut.....						
	Diagonal.....						
40	Upper frame.....	(2)	1 by 4	1 by 4	1 by 4	2 by 4	2 by 4
	Lower frame.....						
	Strut.....						
	Diagonal.....						
44	Upper frame.....	(2)	1 by 4	1 by 4	1 by 4	2 by 4	2 by 4
	Lower frame.....						
	Strut.....						
	Diagonal.....						
48	Upper frame.....	(2)	1 by 4	1 by 4	1 by 4	2 by 4	2 by 4
	Lower frame.....						
	Strut.....						
	Diagonal.....						

<sup>1</sup> With horizontal joist supports, except as indicated.

<sup>2</sup> Crates require special design.

<sup>3</sup> Crates require 2 by 4 vertical joist supports when struts are 1 inch thick.

TABLE 27.—Panel member sizes for crates<sup>1</sup> designed for a net load of 2,000 pounds  
4-FOOT-WIDE CRATE

Length	Member	Crate height					
		2 feet	4 feet	6 feet	8 feet	10 feet	12 feet
<i>Ft.</i>		<i>In.</i>	<i>In.</i>	<i>In.</i>	<i>In.</i>	<i>In.</i>	<i>In.</i>
6	Upper frame.....	1 by 4	1 by 4	1 by 4	1 by 4	1 by 4	1 by 4
	Lower frame.....						
	Strut.....						
8	Diagonal.....	1 by 4	1 by 4	1 by 4	1 by 4	1 by 4	1 by 4
	Upper frame.....						
	Lower frame.....						
10	Strut.....	1 by 4	1 by 4	1 by 4	1 by 4	1 by 4	1 by 4
	Diagonal.....						
	Upper frame.....						
12	Lower frame.....	1 by 4	1 by 4	1 by 4	1 by 4	1 by 4	1 by 4
	Strut.....						
	Diagonal.....						
16	Upper frame.....	1 by 4	1 by 4	1 by 4	1 by 4	1 by 4	1 by 4
	Lower frame.....						
	Strut.....						
20	Diagonal.....	1 by 4	1 by 4	1 by 4	1 by 4	1 by 4	1 by 4
	Upper frame.....						
	Lower frame.....						
24	Strut.....	(2)	1 by 4	1 by 4	1 by 4	1 by 4	1 by 4
	Diagonal.....						
	Upper frame.....						
28	Lower frame.....	(2)	1 by 4	1 by 4	1 by 4	1 by 4	1 by 4
	Strut.....						
	Diagonal.....						
32	Upper frame.....	(2)	1 by 4	1 by 4	2 by 4	1 by 4	1 by 4
	Lower frame.....						
	Strut.....						
36	Diagonal.....	(2)	1 by 4	1 by 4	1 by 4	1 by 4	1 by 4
	Upper frame.....						
	Lower frame.....						
40	Strut.....	(2)	1 by 4	1 by 4	1 by 4	1 by 4	1 by 4
	Diagonal.....						
	Upper frame.....						
44	Lower frame.....	(2)	1 by 4	1 by 4	1 by 4	1 by 4	1 by 4
	Strut.....						
	Diagonal.....						
48	Upper frame.....	(2)	1 by 4	1 by 4	1 by 4	1 by 4	1 by 4
	Lower frame.....						
	Strut.....						
	Diagonal.....	(2)	1 by 4	1 by 4	1 by 6		1 by 6

See footnotes at end of table.

TABLE 27.—Panel member sizes for crates<sup>1</sup> designed for a net load of 2,000 pounds—Continued

6-FOOT-WIDE CRATE

Length	Member	Crate height					
		2 feet	4 feet	6 feet	8 feet	10 feet	*12 feet
<i>Ft.</i>		<i>In.</i>	<i>In.</i>	<i>In.</i>	<i>In.</i>	<i>In.</i>	<i>In.</i>
6	Upper frame.....	1 by 4	1 by 4	1 by 4	1 by 4	1 by 4	1 by 4
	Lower frame.....						
	Strut.....						
	Diagonal.....						
8	Upper frame.....	1 by 4	1 by 4	1 by 4	1 by 4	1 by 4	1 by 4
	Lower frame.....						
	Strut.....						
	Diagonal.....						
10	Upper frame.....	1 by 4	1 by 4	1 by 4	1 by 4	1 by 4	1 by 4
	Lower frame.....						
	Strut.....						
	Diagonal.....						
12	Upper frame.....	1 by 4	1 by 4	1 by 4	1 by 4	1 by 4	1 by 4
	Lower frame.....						
	Strut.....						
	Diagonal.....						
16	Upper frame.....	1 by 4	1 by 4	1 by 4	1 by 4	1 by 4	1 by 4
	Lower frame.....						
	Strut.....						
	Diagonal.....						
20	Upper frame.....	1 by 4	1 by 4	1 by 4	1 by 4	1 by 4	1 by 4
	Lower frame.....						
	Strut.....						
	Diagonal.....						
24	Upper frame.....	(2)	1 by 4	1 by 4	1 by 4	1 by 4	1 by 4
	Lower frame.....	(2)					
	Strut.....	(2)					
	Diagonal.....	(2)					
28	Upper frame.....	(2)	1 by 4	1 by 4	1 by 4	1 by 4	1 by 4
	Lower frame.....	(2)					
	Strut.....	(2)					
	Diagonal.....	(2)					
32	Upper frame.....	(2)	1 by 4	1 by 4	2 by 4	1 by 4	1 by 4
	Lower frame.....	(2)					
	Strut.....	(2)					
	Diagonal.....	(2)					
36	Upper frame.....	(2)	1 by 4	1 by 4	2 by 4	1 by 4	1 by 4
	Lower frame.....	(2)					
	Strut.....	(2)					
	Diagonal.....	(2)					
40	Upper frame.....	(2)	1 by 4	1 by 4	2 by 4	1 by 4	1 by 4
	Lower frame.....	(2)					
	Strut.....	(2)					
	Diagonal.....	(2)					
44	Upper frame.....	(2)	1 by 4	1 by 4	2 by 4	1 by 4	2 by 4
	Lower frame.....	(2)					
	Strut.....	(2)					
	Diagonal.....	(2)					
48	Upper frame.....	(2)	1 by 4	1 by 4	2 by 4	1 by 4	2 by 4
	Lower frame.....	(2)					
	Strut.....	(2)					
	Diagonal.....	(2)					

See footnotes at end of table.

TABLE 27.—Panel member sizes for crates<sup>1</sup> designed for a net load of 2,000 pounds—Continued  
8-FOOT-WIDE CRATE

Length	Member	Crate height					
		2 feet	4 feet	6 feet	8 feet	<sup>a</sup> 10 feet	12 feet
<i>Ft.</i>		<i>In.</i>	<i>In.</i>	<i>In.</i>	<i>In.</i>	<i>In.</i>	<i>In.</i>
6	Upper frame.....	1 by 4	1 by 4	1 by 4	1 by 4	1 by 4	2 by 4
	Lower frame.....						2 by 4
	Strut.....						2 by 4
	Diagonal.....						1 by 4
8	Upper frame.....	1 by 4	1 by 4	1 by 4	1 by 4	1 by 4	2 by 4
	Lower frame.....						2 by 4
	Strut.....						2 by 4
	Diagonal.....						1 by 4
10	Upper frame.....	1 by 4	1 by 4	1 by 4	1 by 4	1 by 4	2 by 4
	Lower frame.....						2 by 4
	Strut.....						2 by 4
	Diagonal.....						1 by 4
12	Upper frame.....	1 by 4	1 by 4	1 by 4	1 by 4	1 by 4	2 by 4
	Lower frame.....						2 by 4
	Strut.....						2 by 4
	Diagonal.....						1 by 4
16	Upper frame.....	1 by 4	1 by 4	1 by 4	1 by 4	1 by 4	2 by 4
	Lower frame.....						2 by 4
	Strut.....						2 by 4
	Diagonal.....						1 by 4
20	Upper frame.....	1 by 4	1 by 4	1 by 4	1 by 4	1 by 4	2 by 4
	Lower frame.....						2 by 4
	Strut.....						2 by 4
	Diagonal.....						1 by 6
24	Upper frame.....	( <sup>2</sup> )	1 by 6	1 by 4	2 by 4	1 by 4	2 by 4
	Lower frame.....	( <sup>2</sup> )	1 by 4				2 by 4
	Strut.....	( <sup>2</sup> )	1 by 6				2 by 4
	Diagonal.....	( <sup>2</sup> )	1 by 4				1 by 6
28	Upper frame.....	( <sup>2</sup> )	1 by 6	1 by 4	2 by 4	1 by 4	2 by 4
	Lower frame.....	( <sup>2</sup> )	1 by 4				2 by 4
	Strut.....	( <sup>2</sup> )	1 by 6				2 by 4
	Diagonal.....	( <sup>2</sup> )	1 by 4				1 by 6
32	Upper frame.....	( <sup>2</sup> )	1 by 6	1 by 6	2 by 4	1 by 4	2 by 4
	Lower frame.....	( <sup>2</sup> )	1 by 4				2 by 4
	Strut.....	( <sup>2</sup> )	1 by 6				2 by 4
	Diagonal.....	( <sup>2</sup> )	1 by 4				1 by 6
36	Upper frame.....	( <sup>2</sup> )	1 by 6	1 by 6	2 by 4	1 by 4	2 by 4
	Lower frame.....	( <sup>2</sup> )	1 by 4				2 by 4
	Strut.....	( <sup>2</sup> )	1 by 6				2 by 4
	Diagonal.....	( <sup>2</sup> )	1 by 4				1 by 6
40	Upper frame.....	( <sup>2</sup> )	2 by 4	1 by 6	2 by 4	1 by 6	2 by 4
	Lower frame.....	( <sup>2</sup> )	1 by 4				2 by 4
	Strut.....	( <sup>2</sup> )	1 by 6				2 by 4
	Diagonal.....	( <sup>2</sup> )	1 by 4				1 by 6
44	Upper frame.....	( <sup>2</sup> )	2 by 6	1 by 6	2 by 4	2 by 4	2 by 4
	Lower frame.....	( <sup>2</sup> )	1 by 4				2 by 4
	Strut.....	( <sup>2</sup> )	1 by 6				2 by 4
	Diagonal.....	( <sup>2</sup> )	1 by 4				1 by 6
48	Upper frame.....	( <sup>2</sup> )	2 by 6	2 by 6	2 by 4	2 by 4	2 by 4
	Lower frame.....	( <sup>2</sup> )	1 by 4				2 by 4
	Strut.....	( <sup>2</sup> )	1 by 6				2 by 4
	Diagonal.....	( <sup>2</sup> )	1 by 4				1 by 6

See footnotes at end of table.

TABLE 27.—Panel member sizes for crates <sup>1</sup> designed for a net load of 2,000 pounds-Continued  
10-FOOT-WIDE CRATE

Length	Member	Crate height					
		2 feet	4 feet	6 feet	8 feet	10 feet	12 feet
Ft.		In.	In.	In.	In.	In.	In.
6	Upper frame.....	1 by 4	1 by 4	1 by 4	1 by 4	2 by 4	2 by 4
	Lower frame.....					2 by 4	2 by 4
	Strut.....					2 by 4	2 by 4
8	Diagonal.....	1 by 4	1 by 4	1 by 4	1 by 4	1 by 4	1 by 4
	Upper frame.....					2 by 4	2 by 4
	Lower frame.....					2 by 4	2 by 4
10	Strut.....	1 by 4	1 by 4	1 by 4	1 by 4	2 by 4	2 by 4
	Diagonal.....					1 by 4	1 by 4
	Upper frame.....					2 by 4	2 by 4
12	Lower frame.....	1 by 4	1 by 4	1 by 4	1 by 4	2 by 4	2 by 4
	Strut.....					1 by 4	1 by 4
	Diagonal.....					2 by 4	2 by 4
16	Upper frame.....	1 by 4	1 by 4	1 by 4	1 by 4	2 by 4	2 by 4
	Lower frame.....		1 by 4			2 by 4	
	Strut.....		1 by 6			2 by 4	
20	Diagonal.....	1 by 4	1 by 4	1 by 4	2 by 4	1 by 4	1 by 6
	Upper frame.....		1 by 4			2 by 4	
	Lower frame.....		1 by 4			2 by 4	
24	Strut.....	1 by 4	1 by 6	1 by 4	2 by 4	2 by 4	2 by 4
	Diagonal.....		1 by 4			1 by 6	
	Upper frame.....		2 by 4			2 by 4	
28	Lower frame.....	1 by 4	1 by 4	1 by 4	2 by 4	2 by 4	2 by 4
	Strut.....		1 by 6			2 by 4	
	Diagonal.....		1 by 4			1 by 4	
32	Upper frame.....	1 by 4	2 by 4	1 by 4	2 by 4	2 by 4	2 by 4
	Lower frame.....		1 by 4			1 by 4	
	Strut.....		1 by 6			1 by 6	
36	Diagonal.....	1 by 4	1 by 4	1 by 4	2 by 4	2 by 4	2 by 4
	Upper frame.....		2 by 4			1 by 6	
	Lower frame.....		1 by 4			1 by 4	
40	Strut.....	1 by 4	1 by 8	1 by 4	2 by 4	2 by 4	2 by 4
	Diagonal.....		1 by 4			1 by 6	
	Upper frame.....		2 by 6			2 by 6	
44	Lower frame.....	1 by 4	1 by 4	1 by 4	2 by 4	2 by 4	2 by 4
	Strut.....		1 by 8			1 by 6	
	Diagonal.....		1 by 4			1 by 6	
48	Upper frame.....	1 by 4	2 by 6	2 by 4	2 by 4	2 by 6	2 by 6
	Lower frame.....		1 by 6			2 by 4	
	Strut.....		1 by 8			2 by 4	
	Diagonal.....	( <sup>2</sup> )	1 by 4	2 by 4	2 by 6	2 by 4	2 by 4

<sup>1</sup> With horizontal joist supports, except as indicated.

<sup>2</sup> Crates require special design.

<sup>3</sup> Crates require 2 by 4 vertical joist supports when struts are 1 inch thick.

TABLE 28.—Panel member sizes for crates <sup>1</sup> designed for a net load of 4,000 pounds  
4-FOOT-WIDE CRATE

Length	Member	Crate height					
		2 feet	4 feet	6 feet	8 feet	10 feet	12 feet
<i>Ft.</i>		<i>In.</i>	<i>In.</i>	<i>In.</i>	<i>In.</i>	<i>In.</i>	<i>In.</i>
6	Upper frame.....	1 by 4	1 by 4	1 by 4	1 by 4	1 by 4	1 by 4
	Lower frame.....						
	Strut.....						
	Diagonal.....						
8	Upper frame.....	1 by 4	1 by 4	1 by 4	1 by 4	1 by 4	1 by 4
	Lower frame.....						
	Strut.....						
	Diagonal.....						
10	Upper frame.....	1 by 4	1 by 4	1 by 4	1 by 4	1 by 4	1 by 4
	Lower frame.....						
	Strut.....						
	Diagonal.....						
12	Upper frame.....	1 by 4	1 by 4	1 by 4	1 by 4	1 by 4	1 by 4
	Lower frame.....						
	Strut.....						
	Diagonal.....						
16	Upper frame.....	1 by 6	1 by 4	1 by 4	1 by 4	1 by 4	1 by 4
	Lower frame.....						
	Strut.....						
	Diagonal.....						
20	Upper frame.....	1 by 6	1 by 4	1 by 4	1 by 4	1 by 4	1 by 4
	Lower frame.....						
	Strut.....						
	Diagonal.....						
24	Upper frame.....	(2)	1 by 6	1 by 4	1 by 4	1 by 4	1 by 4
	Lower frame.....						
	Strut.....						
	Diagonal.....						
28	Upper frame.....	(2)	1 by 6	1 by 4	1 by 4	1 by 4	1 by 4
	Lower frame.....						
	Strut.....						
	Diagonal.....						
32	Upper frame.....	(2)	2 by 4	1 by 4	2 by 4	1 by 4	1 by 4
	Lower frame.....						
	Strut.....						
	Diagonal.....						
36	Upper frame.....	(2)	2 by 4	1 by 6	2 by 4	1 by 4	1 by 4
	Lower frame.....						
	Strut.....						
	Diagonal.....						
40	Upper frame.....	(2)	2 by 6	1 by 6	2 by 4	1 by 6	1 by 4
	Lower frame.....						
	Strut.....						
	Diagonal.....						
44	Upper frame.....	(2)	2 by 6	1 by 6	2 by 4	1 by 6	2 by 4
	Lower frame.....						
	Strut.....						
	Diagonal.....						
48	Upper frame.....	(2)	2 by 6	2 by 6	2 by 4	1 by 6	2 by 4
	Lower frame.....						
	Strut.....						
	Diagonal.....						

See footnotes at end of table.

TABLE 28.—Panel member sizes for crates <sup>1</sup> designed for a net load of 4,000 pounds—Continued  
6-FOOT-WIDE CRATE

Length	Member	Crate height					
		2 feet	4 feet	6 feet	8 feet	10 feet	<sup>a</sup> 12 feet
<i>Ft.</i>		<i>In.</i>	<i>In.</i>	<i>In.</i>	<i>In.</i>	<i>In.</i>	<i>In.</i>
6	Upper frame -----	1 by 4	1 by 4	1 by 4	1 by 4	1 by 4	1 by 4
	Lower frame -----						
	Strut -----						
8	Diagonal -----	1 by 4	1 by 4	1 by 4	1 by 4	1 by 4	1 by 4
	Upper frame -----						
	Lower frame -----						
10	Strut -----	1 by 4	1 by 4	1 by 4	1 by 4	1 by 4	1 by 4
	Diagonal -----						
	Upper frame -----						
12	Lower frame -----	1 by 4	1 by 4	1 by 4	1 by 4	1 by 4	1 by 4
	Strut -----						
	Diagonal -----						
16	Upper frame -----	1 by 4	1 by 4	1 by 4	1 by 4	1 by 4	1 by 4
	Lower frame -----						
	Strut -----						
20	Diagonal -----	1 by 4	1 by 4	1 by 4	1 by 4	1 by 4	1 by 4
	Upper frame -----						
	Lower frame -----						
24	Strut -----	1 by 4	1 by 4	1 by 4	1 by 4	1 by 4	1 by 4
	Diagonal -----						
	Upper frame -----						
28	Lower frame -----	1 by 4	1 by 4	1 by 4	1 by 4	1 by 4	1 by 4
	Strut -----						
	Diagonal -----						
32	Upper frame -----	1 by 4	1 by 4	1 by 4	1 by 4	1 by 4	1 by 4
	Lower frame -----						
	Strut -----						
36	Diagonal -----	1 by 4	1 by 4	1 by 4	1 by 4	1 by 4	1 by 4
	Upper frame -----						
	Lower frame -----						
40	Strut -----	1 by 4	1 by 4	1 by 4	1 by 4	1 by 4	1 by 4
	Diagonal -----						
	Upper frame -----						
44	Lower frame -----	1 by 4	1 by 4	1 by 4	1 by 4	1 by 4	1 by 4
	Strut -----						
	Diagonal -----						
48	Upper frame -----	1 by 4	1 by 4	1 by 4	1 by 4	1 by 4	1 by 4
	Lower frame -----						
	Strut -----						
	Diagonal -----	( <sup>2</sup> )	1 by 4	1 by 6	2 by 4	1 by 6	2 by 4

See footnotes at end of table.

TABLE 28.—Panel member sizes for crates<sup>1</sup> designed for a net load of 4,000 pounds—Continued  
8-FOOT-WIDE CRATE

Length	Member	Crate height					
		2 feet	4 feet	6 feet	8 feet	10 feet	12 feet
<i>Ft.</i>		<i>In.</i>	<i>In.</i>	<i>In.</i>	<i>In.</i>	<i>In.</i>	<i>In.</i>
6	Upper frame.....	1 by 4	1 by 4	1 by 4	1 by 4	1 by 4	2 by 4
	Lower frame.....						
	Strut.....						
	Diagonal.....						
8	Upper frame.....	1 by 4	1 by 4	1 by 4	1 by 4	1 by 4	2 by 4
	Lower frame.....						
	Strut.....						
	Diagonal.....						
10	Upper frame.....	1 by 4	1 by 4	1 by 4	2 by 4	1 by 4	2 by 4
	Lower frame.....						
	Strut.....						
	Diagonal.....						
12	Upper frame.....	1 by 4	1 by 4	1 by 4	1 by 4	1 by 4	2 by 4
	Lower frame.....						
	Strut.....						
	Diagonal.....						
16	Upper frame.....	1 by 6	1 by 4	1 by 4	2 by 4	1 by 4	2 by 4
	Lower frame.....						
	Strut.....						
	Diagonal.....						
20	Upper frame.....	2 by 4	1 by 4	1 by 4	2 by 4	1 by 4	2 by 4
	Lower frame.....						
	Strut.....						
	Diagonal.....						
24	Upper frame.....	(2)	1 by 6	1 by 6	2 by 4	1 by 4	2 by 4
	Lower frame.....						
	Strut.....						
	Diagonal.....						
28	Upper frame.....	(2)	1 by 6	1 by 6	2 by 4	1 by 4	2 by 4
	Lower frame.....						
	Strut.....						
	Diagonal.....						
32	Upper frame.....	(2)	2 by 6	1 by 6	2 by 4	1 by 4	2 by 4
	Lower frame.....						
	Strut.....						
	Diagonal.....						
36	Upper frame.....	(2)	2 by 6	2 by 4	2 by 4	2 by 4	2 by 4
	Lower frame.....						
	Strut.....						
	Diagonal.....						
40	Upper frame.....	(2)	2 by 6	2 by 4	2 by 4	2 by 4	2 by 4
	Lower frame.....						
	Strut.....						
	Diagonal.....						
44	Upper frame.....	(2)	2 by 6	2 by 6	2 by 4	2 by 4	2 by 4
	Lower frame.....						
	Strut.....						
	Diagonal.....						
48	Upper frame.....	(2)	2 by 8	2 by 6	2 by 6	2 by 6	2 by 6
	Lower frame.....						
	Strut.....						
	Diagonal.....						

See footnotes at end of table.

TABLE 28.—Panel member sizes for crates <sup>1</sup> designed for a net load of 4,000 pounds—Continued  
10-FOOT-WIDE CRATE

Length	Member	Crate height					
		2 feet	4 feet	6 feet	8 feet	10 feet	12 feet
6	Upper frame.....	1 by 4	1 by 4	1 by 4	1 by 4	2 by 4	2 by 4
	Lower frame.....						
Strut.....							
Diagonal.....							
8	Upper frame.....	1 by 4	1 by 4	1 by 4	1 by 4	2 by 4	2 by 4
	Lower frame.....						
Strut.....							
Diagonal.....							
10	Upper frame.....	1 by 4	1 by 4	1 by 4	2 by 4	2 by 4	2 by 4
	Lower frame.....						
Strut.....							
Diagonal.....							
12	Upper frame.....	1 by 4	1 by 4	1 by 4	2 by 4	2 by 4	2 by 4
	Lower frame.....						
Strut.....							
Diagonal.....							
16	Upper frame.....	1 by 6	1 by 4	1 by 4	2 by 4	2 by 4	2 by 4
	Lower frame.....						
Strut.....							
Diagonal.....							
20	Upper frame.....	2 by 6	1 by 4	1 by 4	2 by 4	2 by 4	2 by 4
	Lower frame.....						
Strut.....							
Diagonal.....							
24	Upper frame.....	(2)	1 by 6	1 by 6	2 by 4	2 by 4	2 by 4
	Lower frame.....						
Strut.....							
Diagonal.....							
28	Upper frame.....	(2)	2 by 4	1 by 6	2 by 4	2 by 4	2 by 4
	Lower frame.....						
Strut.....							
Diagonal.....							
32	Upper frame.....	(2)	2 by 6	1 by 6	2 by 4	2 by 4	2 by 4
	Lower frame.....						
Strut.....							
Diagonal.....							
36	Upper frame.....	(2)	2 by 6	2 by 6	2 by 4	2 by 4	2 by 4
	Lower frame.....						
Strut.....							
Diagonal.....							
40	Upper frame.....	(2)	2 by 6	2 by 6	2 by 6	2 by 6	2 by 6
	Lower frame.....						
Strut.....							
Diagonal.....							
44	Upper frame.....	(2)	2 by 8	2 by 6	2 by 6	2 by 6	2 by 6
	Lower frame.....						
Strut.....							
Diagonal.....							
48	Upper frame.....	(2)	2 by 8	2 by 6	2 by 6	2 by 6	2 by 6
	Lower frame.....						
Strut.....							
Diagonal.....							

<sup>1</sup> With horizontal joist supports, except as indicated.

<sup>2</sup> Crates require special design.

<sup>3</sup> Crates require 2 by 4 vertical joist supports when struts are 1 inch thick.

TABLE 29.—Panel member sizes for crates <sup>1</sup> designed for a net load of 6,000 pounds  
4-FOOT-WIDE CRATE

Length	Member	Crate height					
		2 feet	4 feet	6 feet	8 feet	10 feet	12 feet
<i>Ft.</i>		<i>In.</i>	<i>In.</i>	<i>In.</i>	<i>In.</i>	<i>In.</i>	<i>In.</i>
6	Upper frame.....	1 by 4	1 by 4	1 by 4	1 by 4	1 by 4	1 by 4
	Lower frame.....				1 by 4		
	Strut.....				1 by 4		
8	Upper frame.....	1 by 4	1 by 4	1 by 4	1 by 4	1 by 4	1 by 4
	Lower frame.....				1 by 4		1 by 4
	Strut.....				1 by 4		1 by 4
10	Upper frame.....	1 by 4	1 by 4	1 by 4	2 by 4	1 by 4	1 by 4
	Lower frame.....						
	Strut.....						
12	Upper frame.....	1 by 6	1 by 4	1 by 4	2 by 4	1 by 4	1 by 4
	Lower frame.....	1 by 4					
	Strut.....	1 by 4					
16	Upper frame.....	2 by 6	1 by 4	1 by 4	2 by 4	1 by 4	1 by 4
	Lower frame.....	1 by 4					
	Strut.....	1 by 4					
20	Upper frame.....	2 by 6	1 by 4	1 by 4	2 by 4	1 by 4	1 by 4
	Lower frame.....	1 by 4					1 by 4
	Strut.....	1 by 4					1 by 4
24	Upper frame.....	( <sup>2</sup> )	2 by 4	1 by 4	2 by 4	1 by 4	1 by 4
	Lower frame.....	( <sup>2</sup> )	1 by 4				1 by 4
	Strut.....	( <sup>2</sup> )	1 by 4				1 by 4
28	Upper frame.....	( <sup>2</sup> )	2 by 4	1 by 4	2 by 4	1 by 4	1 by 4
	Lower frame.....	( <sup>2</sup> )	1 by 4				1 by 4
	Strut.....	( <sup>2</sup> )	1 by 4				1 by 4
32	Upper frame.....	( <sup>2</sup> )	2 by 6	1 by 4	2 by 4	1 by 4	1 by 4
	Lower frame.....	( <sup>2</sup> )	1 by 4				1 by 4
	Strut.....	( <sup>2</sup> )	1 by 4				1 by 4
36	Upper frame.....	( <sup>2</sup> )	2 by 6	1 by 4	2 by 4	1 by 4	1 by 4
	Lower frame.....	( <sup>2</sup> )	1 by 4				1 by 4
	Strut.....	( <sup>2</sup> )	1 by 4				1 by 4
40	Upper frame.....	( <sup>2</sup> )	2 by 6	1 by 4	2 by 4	1 by 4	1 by 4
	Lower frame.....	( <sup>2</sup> )	1 by 4				1 by 4
	Strut.....	( <sup>2</sup> )	1 by 4				1 by 4
44	Upper frame.....	( <sup>2</sup> )	2 by 8	1 by 4	2 by 4	1 by 4	1 by 4
	Lower frame.....	( <sup>2</sup> )	1 by 4				1 by 4
	Strut.....	( <sup>2</sup> )	1 by 4				1 by 4
48	Upper frame.....	( <sup>2</sup> )	2 by 8	1 by 4	2 by 4	1 by 4	1 by 4
	Lower frame.....	( <sup>2</sup> )	1 by 4				1 by 4
	Strut.....	( <sup>2</sup> )	1 by 4				1 by 4
	Diagonal.....	( <sup>2</sup> )	1 by 4	1 by 6			1 by 6

See footnotes at end of table.

TABLE 29.—Panel member sizes for crates<sup>1</sup> designed for a net load of 6,000 pounds—Continued  
6-FOOT-WIDE CRATE

Length	Member	Crate height					
		2 feet	4 feet	6 feet	8 feet	10 feet	<sup>3</sup> 12 feet
<i>Ft.</i>		<i>In.</i>	<i>In.</i>	<i>In.</i>	<i>In.</i>	<i>In.</i>	<i>In.</i>
6	Upper frame.....	1 by 4	1 by 4	1 by 4	1 by 4	1 by 4	1 by 4
	Lower frame.....						
	Strut.....						
	Diagonal.....						
8	Upper frame.....	1 by 4	1 by 4	1 by 4	2 by 4	1 by 4	1 by 4
	Lower frame.....						
	Strut.....						
	Diagonal.....						
10	Upper frame.....	1 by 4	1 by 4	1 by 4	2 by 4	1 by 4	1 by 4
	Lower frame.....						
	Strut.....						
	Diagonal.....						
12	Upper frame.....	1 by 6	1 by 4	1 by 4	2 by 4	1 by 4	1 by 4
	Lower frame.....						
	Strut.....						
	Diagonal.....						
16	Upper frame.....	2 by 6	1 by 4	1 by 4	2 by 4	1 by 4	1 by 4
	Lower frame.....						
	Strut.....						
	Diagonal.....						
20	Upper frame.....	2 by 6	1 by 6	1 by 4	2 by 4	1 by 4	1 by 4
	Lower frame.....						
	Strut.....						
	Diagonal.....						
24	Upper frame.....	(2)	2 by 4	1 by 6	2 by 4	1 by 4	2 by 4
	Lower frame.....						
	Strut.....						
	Diagonal.....						
28	Upper frame.....	(2)	1 by 4	1 by 6	2 by 4	1 by 4	2 by 4
	Lower frame.....						
	Strut.....						
	Diagonal.....						
32	Upper frame.....	(2)	2 by 6	1 by 6	2 by 4	1 by 4	2 by 4
	Lower frame.....						
	Strut.....						
	Diagonal.....						
36	Upper frame.....	(2)	2 by 6	2 by 6	2 by 4	1 by 6	2 by 4
	Lower frame.....						
	Strut.....						
	Diagonal.....						
40	Upper frame.....	(2)	2 by 8	2 by 4	2 by 4	2 by 4	2 by 4
	Lower frame.....						
	Strut.....						
	Diagonal.....						
44	Upper frame.....	(2)	2 by 8	2 by 6	2 by 4	2 by 4	2 by 4
	Lower frame.....						
	Strut.....						
	Diagonal.....						
48	Upper frame.....	(2)	2 by 10	2 by 6	2 by 6	2 by 6	2 by 6
	Lower frame.....						
	Strut.....						
	Diagonal.....						

See footnotes at end of table.

TABLE 29.—Panel member sizes for crates <sup>1</sup> designed for a net load of 6,000 pounds—Continued  
8-FOOT-WIDE CRATE

Length	Member	Crate height					
		2 feet	4 feet	6 feet	8 feet	*10 feet	12 feet
<i>Ft.</i>		<i>In.</i>	<i>In.</i>	<i>In.</i>	<i>In.</i>	<i>In.</i>	<i>In.</i>
6	Upper frame.....	1 by 4	1 by 4	1 by 4	1 by 4 1 by 4 1 by 4 1 by 6	1 by 4	2 by 4
	Lower frame.....						
	Strut.....						
	Diagonal.....						
8	Upper frame.....	1 by 4	1 by 4	1 by 4 1 by 4 1 by 4 1 by 6	2 by 4	1 by 4	2 by 4 2 by 4 2 by 4 1 by 6
	Lower frame.....						
	Strut.....						
	Diagonal.....						
10	Upper frame.....	1 by 4	1 by 4	1 by 4	2 by 4	1 by 4	2 by 4 2 by 4 2 by 4 1 by 6
	Lower frame.....						
	Strut.....						
	Diagonal.....						
12	Upper frame.....	1 by 6 1 by 4 1 by 4 1 by 4	1 by 4	1 by 4	2 by 4	1 by 4 1 by 4 1 by 4 1 by 6	2 by 4 2 by 4 2 by 4 1 by 6
	Lower frame.....						
	Strut.....						
	Diagonal.....						
16	Upper frame.....	2 by 6 1 by 4 1 by 4 1 by 4	1 by 4	1 by 4	2 by 4	1 by 4 1 by 4 1 by 4 1 by 6	2 by 4 2 by 4 2 by 4 1 by 6
	Lower frame.....						
	Strut.....						
	Diagonal.....						
20	Upper frame.....	2 by 6 1 by 4 1 by 4 1 by 4	1 by 6 1 by 4 1 by 4 1 by 4	1 by 4 1 by 4 1 by 4 1 by 6	2 by 4	1 by 4 1 by 4 1 by 6 1 by 6	2 by 4
	Lower frame.....						
	Strut.....						
	Diagonal.....						
24	Upper frame.....	(2) (2) (2) (2)	2 by 6 1 by 4 1 by 6 1 by 4	1 by 6 1 by 4 1 by 4 1 by 6	2 by 4	2 by 4	2 by 4
	Lower frame.....						
	Strut.....						
	Diagonal.....						
28	Upper frame.....	(2) (2) (2) (2)	2 by 6 1 by 4 1 by 6 1 by 4	1 by 6 1 by 4 1 by 4 1 by 6	2 by 4	2 by 4	2 by 4
	Lower frame.....						
	Strut.....						
	Diagonal.....						
32	Upper frame.....	(2) (2) (2) (2)	2 by 6 1 by 4 1 by 6 1 by 4	2 by 6 1 by 4 1 by 6 1 by 4	2 by 4	2 by 4	2 by 4 2 by 4 2 by 6 2 by 4
	Lower frame.....						
	Strut.....						
	Diagonal.....						
36	Upper frame.....	(2) (2) (2) (2)	2 by 6 1 by 4 1 by 6 1 by 4	2 by 6 2 by 4 2 by 4 2 by 4	2 by 4	2 by 4	2 by 4 2 by 4 2 by 4 2 by 6
	Lower frame.....						
	Strut.....						
	Diagonal.....						
40	Upper frame.....	(2) (2) (2) (2)	2 by 8 1 by 4 1 by 6 1 by 6	2 by 6 2 by 4 2 by 4 2 by 4	2 by 6 2 by 4 2 by 4 2 by 6	2 by 6 2 by 4 2 by 4 2 by 4	2 by 4 2 by 4 2 by 4 2 by 6
	Lower frame.....						
	Strut.....						
	Diagonal.....						
44	Upper frame.....	(2) (2) (2) (2)	2 by 8 1 by 4 1 by 6 1 by 6	2 by 6 2 by 4 2 by 4 2 by 4	2 by 6 2 by 4 2 by 4 2 by 6	2 by 6 2 by 4 2 by 4 2 by 6	2 by 6 2 by 4 2 by 4 2 by 6
	Lower frame.....						
	Strut.....						
	Diagonal.....						
48	Upper frame.....	(2) (2) (2) (2)	2 by 10 1 by 6 1 by 6 1 by 6	2 by 8 2 by 4 2 by 4 2 by 4	2 by 6 2 by 4 2 by 4 2 by 6	2 by 6 2 by 4 2 by 4 2 by 6	2 by 6 2 by 4 2 by 4 2 by 6
	Lower frame.....						
	Strut.....						
	Diagonal.....						

See footnotes at end of table.

TABLE 29.—Panel member sizes for crates <sup>1</sup> designed for a net load of 6,000 pounds—Continued  
10-FOOT-WIDE CRATE

Length	Member	Crate height					
		2 feet	4 feet	6 feet	8 feet	10 feet	12 feet
<i>Ft.</i>		<i>In.</i>	<i>In.</i>	<i>In.</i>	<i>In.</i>	<i>In.</i>	<i>In.</i>
6	Upper frame.....	1 by 4	1 by 4	1 by 4	2 by 4	2 by 4	2 by 4
	Lower frame.....					2 by 4	2 by 4
	Strut.....					2 by 4	2 by 4
	Diagonal.....					1 by 4	1 by 4
8	Upper frame.....	1 by 4	1 by 4	1 by 4	2 by 4	2 by 4	2 by 4
	Lower frame.....			1 by 4		2 by 4	
	Strut.....			1 by 4		2 by 4	
	Diagonal.....			1 by 6		1 by 4	
10	Upper frame.....	1 by 4	1 by 4	1 by 4	2 by 4	2 by 4	2 by 4
	Lower frame.....			1 by 4		2 by 4	
	Strut.....			1 by 4		2 by 4	
	Diagonal.....			1 by 6		1 by 4	
12	Upper frame.....	1 by 6	1 by 4	1 by 4	2 by 4	2 by 4	2 by 4
	Lower frame.....	1 by 4		1 by 4		2 by 4	
	Strut.....	1 by 4		1 by 4		2 by 4	
	Diagonal.....	1 by 4		1 by 6		1 by 4	
16	Upper frame.....	2 by 6	1 by 4	1 by 4	2 by 4	2 by 4	2 by 4
	Lower frame.....	1 by 4	1 by 4	1 by 4		2 by 4	
	Strut.....	1 by 4	1 by 6	1 by 4		2 by 4	
	Diagonal.....	1 by 4	1 by 4	1 by 6		1 by 4	
20	Upper frame.....	2 by 6	1 by 6	1 by 4	2 by 4	2 by 4	2 by 4
	Lower frame.....	1 by 4	1 by 4	1 by 4		2 by 4	
	Strut.....	1 by 4	1 by 6	1 by 4		2 by 4	
	Diagonal.....	1 by 4	1 by 4	1 by 6		1 by 6	
24	Upper frame.....	( <sup>2</sup> )	2 by 6	1 by 6	2 by 4	2 by 4	2 by 4
	Lower frame.....	( <sup>2</sup> )	1 by 4	1 by 4		2 by 4	
	Strut.....	( <sup>2</sup> )	1 by 6	1 by 4		2 by 4	
	Diagonal.....	( <sup>2</sup> )	1 by 4	1 by 6		1 by 6	
28	Upper frame.....	( <sup>1</sup> )	2 by 6	2 by 4	2 by 4	2 by 4	2 by 4
	Lower frame.....	( <sup>2</sup> )	1 by 4			2 by 4	2 by 4
	Strut.....	( <sup>2</sup> )	1 by 6			2 by 4	2 by 4
	Diagonal.....	( <sup>2</sup> )	1 by 4			2 by 4	2 by 6
32	Upper frame.....	( <sup>2</sup> )	2 by 6	2 by 4	2 by 4	2 by 4	2 by 4
	Lower frame.....	( <sup>2</sup> )	1 by 4		2 by 4	2 by 4	2 by 4
	Strut.....	( <sup>2</sup> )	1 by 6		2 by 4	2 by 4	2 by 4
	Diagonal.....	( <sup>2</sup> )	1 by 6		2 by 4	2 by 6	2 by 6
36	Upper frame.....	( <sup>2</sup> )	2 by 6	2 by 6	2 by 6	2 by 4	2 by 4
	Lower frame.....	( <sup>2</sup> )	1 by 6	2 by 4	2 by 4	2 by 4	2 by 4
	Strut.....	( <sup>2</sup> )	1 by 8	2 by 4	2 by 4	2 by 4	2 by 4
	Diagonal.....	( <sup>2</sup> )	1 by 6	2 by 4	2 by 6	2 by 6	2 by 6
40	Upper frame.....	( <sup>2</sup> )	2 by 8	2 by 6	2 by 6	2 by 6	2 by 4
	Lower frame.....	( <sup>2</sup> )	2 by 4	2 by 4	2 by 4	2 by 4	2 by 4
	Strut.....	( <sup>2</sup> )	2 by 4	2 by 4	2 by 4	2 by 4	2 by 4
	Diagonal.....	( <sup>2</sup> )	1 by 6	2 by 4	2 by 6	2 by 6	2 by 6
44	Upper frame.....	( <sup>2</sup> )	2 by 8	2 by 6	2 by 6	2 by 6	2 by 6
	Lower frame.....	( <sup>2</sup> )	2 by 4	2 by 4	2 by 4	2 by 4	2 by 4
	Strut.....	( <sup>2</sup> )	2 by 4	2 by 4	2 by 4	2 by 4	2 by 4
	Diagonal.....	( <sup>2</sup> )	1 by 6	2 by 4	2 by 6	2 by 6	2 by 6
48	Upper frame.....	( <sup>2</sup> )	2 by 10	2 by 8	2 by 8	2 by 6	2 by 6
	Lower frame.....	( <sup>2</sup> )	2 by 4	2 by 4	2 by 4	2 by 4	2 by 4
	Strut.....	( <sup>2</sup> )	2 by 4	2 by 4	2 by 4	2 by 4	2 by 4
	Diagonal.....	( <sup>2</sup> )	2 by 4	2 by 4	2 by 6	2 by 6	2 by 6

<sup>1</sup> With horizontal joist supports, except as indicated.

<sup>2</sup> Crates require special design.

<sup>3</sup> Crates require 2 by 4 vertical joist supports when struts are 1 inch thick.

TABLE 30.—Panel member sizes for crates<sup>1</sup> designed for a net load of 8,000 pounds  
4-FOOT-WIDE CRATE

Length	Member	Crate height					
		2 feet	4 feet	6 feet	8 feet	10 feet	12 feet
<i>Ft.</i>		<i>In.</i>	<i>In.</i>	<i>In.</i>	<i>In.</i>	<i>In.</i>	<i>In.</i>
6	Upper frame.....	1 by 4	1 by 4	1 by 4	2 by 4	1 by 4	1 by 4
	Lower frame.....			1 by 4			1 by 4
	Strut.....			1 by 4			1 by 4
	Diagonal.....			1 by 6			1 by 4
8	Upper frame.....	1 by 6	1 by 4	1 by 4	2 by 4	1 by 4	2 by 4
	Lower frame.....	1 by 4		1 by 4			
	Strut.....	1 by 4		1 by 4			
	Diagonal.....	1 by 4		1 by 6			
10	Upper frame.....	1 by 6	1 by 4	1 by 4	2 by 4	1 by 4	1 by 4
	Lower frame.....	1 by 4		1 by 4			
	Strut.....	1 by 4		1 by 4			
	Diagonal.....	1 by 4		1 by 6			
12	Upper frame.....	2 by 6	1 by 4	1 by 4	2 by 4	1 by 4	1 by 4
	Lower frame.....	1 by 4		1 by 4			
	Strut.....	1 by 4		1 by 4			
	Diagonal.....	1 by 4		1 by 6			
16	Upper frame.....	2 by 6	1 by 4	1 by 4	2 by 4	1 by 4	1 by 4
	Lower frame.....	1 by 4		1 by 4			
	Strut.....	1 by 4		1 by 4			
	Diagonal.....	1 by 4		1 by 6			
20	Upper frame.....	2 by 8	1 by 6	1 by 4	2 by 4	1 by 4	1 by 4
	Lower frame.....	1 by 4	1 by 4	1 by 4			
	Strut.....	1 by 4	1 by 4	1 by 4			
	Diagonal.....	1 by 4	1 by 6	1 by 6			
24	Upper frame.....	(2)	2 by 6	1 by 6	2 by 4	1 by 4	1 by 4
	Lower frame.....	(2)	1 by 4	1 by 4			
	Strut.....	(2)	1 by 4	1 by 4			
	Diagonal.....	(2)	1 by 4	1 by 6			
28	Upper frame.....	(2)	2 by 6	1 by 6	2 by 4	2 by 4	2 by 4
	Lower frame.....	(2)	1 by 4	1 by 4			
	Strut.....	(2)	1 by 4	1 by 4			
	Diagonal.....	(2)	1 by 4	1 by 6			
32	Upper frame.....	(2)	2 by 8	1 by 6	2 by 4	1 by 4	1 by 4
	Lower frame.....	(2)	1 by 4	1 by 4			
	Strut.....	(2)	1 by 4	1 by 4			
	Diagonal.....	(2)	1 by 4	1 by 6			
36	Upper frame.....	(2)	2 by 8	2 by 6	2 by 4	2 by 4	2 by 4
	Lower frame.....	(2)	1 by 4	2 by 4			
	Strut.....	(2)	1 by 4	2 by 4			
	Diagonal.....	(2)	1 by 6	2 by 4			
40	Upper frame.....	(2)	2 by 8	2 by 6	2 by 4	2 by 4	2 by 4
	Lower frame.....	(2)	1 by 4	1 by 4			
	Strut.....	(2)	1 by 4	1 by 4			
	Diagonal.....	(2)	1 by 6	1 by 6			
44	Upper frame.....	(2)	2 by 8	2 by 6	2 by 4	2 by 4	2 by 4
	Lower frame.....	(2)	1 by 4	2 by 4			
	Strut.....	(2)	1 by 4	2 by 4			
	Diagonal.....	(2)	1 by 6	2 by 4			
48	Upper frame.....	(2)	2 by 10	2 by 8	2 by 6	2 by 6	2 by 6
	Lower frame.....	(2)	1 by 6	2 by 4	2 by 4	2 by 4	2 by 4
	Strut.....	(2)	1 by 4	2 by 4	2 by 4	2 by 4	2 by 4
	Diagonal.....	(2)	1 by 6	2 by 4	2 by 4	2 by 4	2 by 4

See footnotes at end of table.

TABLE 30.—Panel member sizes for crates <sup>1</sup> designed for a net load of 8,000 pounds—Continued  
6-FOOT-WIDE CRATE

Length	Member	Crate height						
		2 feet	4 feet	6 feet	8 feet	10 feet	<sup>3</sup> 12 feet	
<i>Ft.</i>		<i>In.</i>	<i>In.</i>	<i>In.</i>	<i>In.</i>	<i>In.</i>	<i>In.</i>	
6	Upper frame.....	1 by 4	1 by 4	1 by 4	2 by 4	1 by 4	1 by 4	
	Lower frame.....			1 by 4		1 by 4		
	Strut.....			1 by 4		1 by 4		
	Diagonal.....			1 by 6		1 by 6		
8	Upper frame.....	1 by 4	1 by 4	1 by 4	2 by 4	1 by 4	2 by 4	
	Lower frame.....			1 by 4				1 by 4
	Strut.....			1 by 4				1 by 4
	Diagonal.....			1 by 4				1 by 6
10	Upper frame.....	1 by 4	1 by 4	1 by 4	2 by 4	1 by 4	1 by 4	
	Lower frame.....			1 by 4				1 by 4
	Strut.....			1 by 4				1 by 4
	Diagonal.....			1 by 4				1 by 6
12	Upper frame.....	1 by 4	1 by 4	1 by 4	2 by 4	1 by 4	2 by 4	
	Lower frame.....			1 by 4				1 by 4
	Strut.....			1 by 4				1 by 4
	Diagonal.....			1 by 4				1 by 6
16	Upper frame.....	1 by 4	1 by 6	1 by 4	2 by 4	1 by 4	2 by 4	
	Lower frame.....			1 by 4				1 by 4
	Strut.....			1 by 4				1 by 4
	Diagonal.....			1 by 4				1 by 6
20	Upper frame.....	1 by 4	1 by 6	1 by 4	2 by 4	1 by 4	1 by 6	
	Lower frame.....			1 by 4				1 by 4
	Strut.....			1 by 4				1 by 4
	Diagonal.....			1 by 4				1 by 6
24	Upper frame.....	(2)	2 by 6	1 by 4	2 by 4	2 by 4	2 by 4	
	Lower frame.....			1 by 4				1 by 4
	Strut.....			1 by 4				1 by 4
	Diagonal.....			1 by 6				1 by 6
28	Upper frame.....	(2)	2 by 6	2 by 4	2 by 4	2 by 4	2 by 4	
	Lower frame.....			1 by 4				1 by 4
	Strut.....			1 by 4				1 by 4
	Diagonal.....			1 by 6				1 by 6
32	Upper frame.....	(2)	2 by 8	2 by 6	2 by 4	2 by 4	2 by 4	
	Lower frame.....			1 by 4				2 by 4
	Strut.....			1 by 4				2 by 4
	Diagonal.....			1 by 6				2 by 4
36	Upper frame.....	(2)	2 by 8	2 by 4	2 by 4	2 by 4	2 by 4	
	Lower frame.....			1 by 4				2 by 4
	Strut.....			1 by 6				2 by 4
	Diagonal.....			1 by 6				2 by 4
40	Upper frame.....	(2)	2 by 10	2 by 6	2 by 4	2 by 4	2 by 4	
	Lower frame.....			1 by 4				2 by 4
	Strut.....			1 by 6				2 by 4
	Diagonal.....			1 by 6				2 by 4
44	Upper frame.....	(2)	2 by 10	2 by 6	2 by 4	2 by 4	2 by 4	
	Lower frame.....			1 by 4				2 by 4
	Strut.....			1 by 6				2 by 4
	Diagonal.....			1 by 6				2 by 4
48	Upper frame.....	(2)	2 by 10	2 by 8	2 by 4	2 by 4	2 by 6	
	Lower frame.....			2 by 4				2 by 4
	Strut.....			1 by 6				2 by 4
	Diagonal.....			1 by 6				2 by 4

See footnotes at end of table.

TABLE 30.—Panel member sizes for crates<sup>1</sup> designed for a net load of 8,000 pounds—Continued  
8-FOOT-WIDE CRATE

Length	Member	Crate height					
		2 feet	4 feet	6 feet	8 feet	* 10 feet	12 feet
<i>Ft.</i>		<i>In.</i>	<i>In.</i>	<i>In.</i>	<i>In.</i>	<i>In.</i>	<i>In.</i>
6	Upper frame.....	1 by 4	1 by 4	1 by 4	2 by 4	1 by 4	2 by 4
	Lower frame.....			1 by 4		1 by 4	1 by 4
	Strut.....			1 by 4		1 by 4	1 by 4
	Diagonal.....			1 by 6		1 by 6	1 by 6
8	Upper frame.....	1 by 6	1 by 4	2 by 4	2 by 4	1 by 4	2 by 4
	Lower frame.....	1 by 4		1 by 4		1 by 4	
	Strut.....	1 by 4		1 by 4		1 by 4	
	Diagonal.....	1 by 4		1 by 4		1 by 4	
10	Upper frame.....	1 by 6	1 by 4	1 by 4	2 by 4	1 by 4	2 by 4
	Lower frame.....	1 by 4		1 by 4		1 by 4	
	Strut.....	1 by 4		1 by 4		1 by 6	
	Diagonal.....	1 by 4		1 by 6		1 by 6	
12	Upper frame.....	2 by 6	1 by 4	1 by 4	2 by 4	1 by 4	2 by 4
	Lower frame.....	1 by 4		1 by 4		1 by 4	
	Strut.....	1 by 4		1 by 4		1 by 6	
	Diagonal.....	1 by 4		1 by 6		1 by 6	
16	Upper frame.....	2 by 6	1 by 6	1 by 4	2 by 4	1 by 4	2 by 4
	Lower frame.....	1 by 4	1 by 4	1 by 4			
	Strut.....	1 by 4	1 by 4	1 by 4			
	Diagonal.....	1 by 4	1 by 4	1 by 6			
20	Upper frame.....	2 by 8	1 by 6	2 by 4	2 by 4	2 by 4	2 by 4
	Lower frame.....	1 by 4	1 by 4				
	Strut.....	1 by 4	1 by 4				
	Diagonal.....	1 by 4	1 by 6				
24	Upper frame.....	(2)	2 by 6	2 by 4	2 by 4	2 by 4	2 by 4
	Lower frame.....	(2)	1 by 4				
	Strut.....	(2)	1 by 6				
	Diagonal.....	(2)	1 by 6				
28	Upper frame.....	(2)	2 by 6	2 by 6	2 by 4	1 by 6	1 by 6
	Lower frame.....	(2)	1 by 4	2 by 4			
	Strut.....	(2)	1 by 6	2 by 4			
	Diagonal.....	(2)	1 by 6	2 by 4			
32	Upper frame.....	(2)	2 by 8	2 by 6	2 by 6	2 by 4	2 by 4
	Lower frame.....	(2)	1 by 4	2 by 4	2 by 4	2 by 4	2 by 4
	Strut.....	(2)	1 by 6	2 by 4	2 by 4	2 by 4	2 by 4
	Diagonal.....	(2)	1 by 6	2 by 4	2 by 6	2 by 6	2 by 6
36	Upper frame.....	(2)	2 by 8	2 by 6	2 by 6	2 by 4	2 by 4
	Lower frame.....	(2)	1 by 4	2 by 4	2 by 4	2 by 4	2 by 4
	Strut.....	(2)	1 by 6	2 by 4	2 by 4	2 by 4	2 by 4
	Diagonal.....	(2)	1 by 6	2 by 4	2 by 6	2 by 6	2 by 6
40	Upper frame.....	(2)	2 by 10	2 by 6	2 by 6	2 by 6	2 by 4
	Lower frame.....	(2)	1 by 6	2 by 4	2 by 4	2 by 4	2 by 4
	Strut.....	(2)	1 by 6	2 by 4	2 by 4	2 by 4	2 by 4
	Diagonal.....	(2)	1 by 6	2 by 4	2 by 6	2 by 6	2 by 6
44	Upper frame.....	(2)	2 by 10	2 by 8	2 by 8	2 by 6	2 by 6
	Lower frame.....	(2)	1 by 6	2 by 4	2 by 4	2 by 4	2 by 4
	Strut.....	(2)	1 by 6	2 by 4	2 by 4	2 by 4	2 by 4
	Diagonal.....	(2)	1 by 6	2 by 4	2 by 6	2 by 6	2 by 6
48	Upper frame.....	(2)	2 by 12	2 by 8	2 by 8	2 by 6	2 by 6
	Lower frame.....	(2)	2 by 6	2 by 4	2 by 4	2 by 4	2 by 4
	Strut.....	(2)	2 by 4	2 by 4	2 by 4	2 by 4	2 by 4
	Diagonal.....	(2)	2 by 4	2 by 4	2 by 6	2 by 6	2 by 6

See footnotes at end of table.

TABLE 30.—Panel member sizes for crates <sup>1</sup> designed for a net load of 8,000 pounds—Continued  
10-FOOT-WIDE CRATE

Length <i>Ft.</i>	Member	Crate height					
		2 feet	4 feet	6 feet	8 feet	10 feet	12 feet
		<i>In.</i>	<i>In.</i>	<i>In.</i>	<i>In.</i>	<i>In.</i>	<i>In.</i>
6	Upper frame.....	1 by 4	1 by 4	1 by 4	2 by 4	2 by 4	2 by 4
	Lower frame.....			1 by 4		2 by 4	
	Strut.....			1 by 4		2 by 4	
	Diagonal.....			1 by 6		1 by 6	
8	Upper frame.....	1 by 6	1 by 4	2 by 4	2 by 4	2 by 4	2 by 4
	Lower frame.....	1 by 4				2 by 4	
	Strut.....	1 by 4				2 by 4	
	Diagonal.....	1 by 4				1 by 4	
10	Upper frame.....	1 by 6	1 by 4	1 by 4	2 by 4	2 by 4	2 by 4
	Lower frame.....	1 by 4		1 by 4			
	Strut.....	1 by 4		1 by 4			
	Diagonal.....	1 by 4		1 by 6			
12	Upper frame.....	2 by 6	1 by 4	1 by 4	2 by 4	2 by 4	2 by 4
	Lower frame.....	1 by 4		1 by 4			
	Strut.....	1 by 4		1 by 4			
	Diagonal.....	1 by 4		1 by 6			
16	Upper frame.....	2 by 6	1 by 6	1 by 4	2 by 4	2 by 4	2 by 4
	Lower frame.....	1 by 4	1 by 4	1 by 4			
	Strut.....	1 by 4	1 by 6	1 by 4			
	Diagonal.....	1 by 4	1 by 6	1 by 6			
20	Upper frame.....	2 by 8	2 by 4	2 by 4	2 by 4	2 by 4	2 by 4
	Lower frame.....	1 by 4	1 by 4				
	Strut.....	1 by 4	1 by 6				
	Diagonal.....	1 by 4	1 by 6				
24	Upper frame.....	( <sup>2</sup> )	2 by 6	2 by 4	2 by 4	2 by 4	2 by 4
	Lower frame.....	( <sup>2</sup> )	1 by 4			2 by 4	
	Strut.....	( <sup>2</sup> )	1 by 6			2 by 4	
	Diagonal.....	( <sup>2</sup> )	1 by 6			2 by 6	
28	Upper frame.....	( <sup>2</sup> )	2 by 6	2 by 6	2 by 6	2 by 4	2 by 4
	Lower frame.....	( <sup>2</sup> )	1 by 4	2 by 4	2 by 4	2 by 4	2 by 4
	Strut.....	( <sup>2</sup> )	1 by 6	2 by 4	2 by 4	2 by 4	2 by 4
	Diagonal.....	( <sup>2</sup> )	1 by 6	2 by 4	2 by 6	2 by 6	2 by 6
32	Upper frame.....	( <sup>2</sup> )	2 by 8	2 by 6	2 by 6	2 by 4	2 by 4
	Lower frame.....	( <sup>2</sup> )	1 by 4	2 by 4	2 by 4	2 by 4	2 by 4
	Strut.....	( <sup>2</sup> )	1 by 6	2 by 4	2 by 4	2 by 4	2 by 4
	Diagonal.....	( <sup>2</sup> )	1 by 6	2 by 4	2 by 6	2 by 6	2 by 6
36	Upper frame.....	( <sup>2</sup> )	2 by 8	2 by 6	2 by 6	2 by 6	2 by 4
	Lower frame.....	( <sup>2</sup> )	2 by 4	2 by 4	2 by 4	2 by 4	2 by 4
	Strut.....	( <sup>2</sup> )	2 by 4	2 by 4	2 by 4	2 by 4	2 by 4
	Diagonal.....	( <sup>2</sup> )	1 by 6	2 by 4	2 by 6	2 by 6	2 by 6
40	Upper frame.....	( <sup>2</sup> )	2 by 10	2 by 6	2 by 6	2 by 6	2 by 6
	Lower frame.....	( <sup>2</sup> )	2 by 4	2 by 4	2 by 4	2 by 4	2 by 4
	Strut.....	( <sup>2</sup> )	2 by 4	2 by 4	2 by 4	2 by 4	2 by 4
	Diagonal.....	( <sup>2</sup> )	2 by 4	2 by 4	2 by 6	2 by 6	2 by 6
44	Upper frame.....	( <sup>2</sup> )	2 by 10	2 by 8	2 by 8	2 by 6	2 by 6
	Lower frame.....	( <sup>2</sup> )	2 by 4	2 by 4	2 by 4	2 by 4	2 by 4
	Strut.....	( <sup>2</sup> )	2 by 4	2 by 4	2 by 4	2 by 4	2 by 4
	Diagonal.....	( <sup>2</sup> )	2 by 4	2 by 6	2 by 6	2 by 6	2 by 6
48	Upper frame.....	( <sup>2</sup> )	2 by 12	2 by 10	2 by 8	2 by 8	2 by 8
	Lower frame.....	( <sup>2</sup> )	2 by 6	2 by 4	2 by 4	2 by 4	2 by 4
	Strut.....	( <sup>2</sup> )	2 by 4	2 by 4	2 by 4	2 by 4	2 by 4
	Diagonal.....	( <sup>2</sup> )	2 by 4	2 by 6	2 by 6	2 by 6	2 by 8

<sup>1</sup> With horizontal joist supports, except as indicated.  
<sup>2</sup> Crates require special design.  
<sup>3</sup> Crates require 2 by 4 vertical joist supports when struts are 1 inch thick.

TABLE 31.—Panel member sizes for crates<sup>1</sup> designed for a net load of 10,000 pounds  
4-FOOT-WIDE CRATE

Length	Member	Crate height						
		2 feet	4 feet	6 feet	8 feet	10 feet	12 feet	
<i>Ft.</i>		<i>In.</i>	<i>In.</i>	<i>In.</i>	<i>In.</i>	<i>In.</i>	<i>In.</i>	
6	Upper frame.....	1 by 4	1 by 4	1 by 4	2 by 4	1 by 4	2 by 4	
	Lower frame.....			1 by 4		1 by 4		
	Strut.....			1 by 4		1 by 6		
	Diagonal.....			1 by 6		1 by 6		
8	Upper frame.....	1 by 6	1 by 4	2 by 4	2 by 4	1 by 4	2 by 4	
	Lower frame.....	1 by 4	1 by 4			1 by 4		
	Strut.....	1 by 4	1 by 4			1 by 6		
	Diagonal.....	1 by 4	1 by 6			1 by 6		
10	Upper frame.....	1 by 6	1 by 4	1 by 4	2 by 4	1 by 4	2 by 4	
	Lower frame.....	1 by 4	1 by 4	1 by 4		1 by 4		
	Strut.....	1 by 4	1 by 4	1 by 6		1 by 6		
	Diagonal.....	1 by 4	1 by 6	1 by 6		1 by 6		
12	Upper frame.....	2 by 6	1 by 4	1 by 4	2 by 4	1 by 4	2 by 4	
	Lower frame.....	1 by 4	1 by 4	1 by 4		1 by 4		
	Strut.....	1 by 4	1 by 4	1 by 6		1 by 6		
	Diagonal.....	1 by 4	1 by 6	1 by 6		1 by 6		
16	Upper frame.....	2 by 8	1 by 6	1 by 4	2 by 4	1 by 4	2 by 4	
	Lower frame.....	1 by 4	1 by 4	1 by 4		1 by 4		
	Strut.....	1 by 4	1 by 4	1 by 4		1 by 6		
	Diagonal.....	1 by 6	1 by 6	1 by 6		1 by 6		
20	Upper frame.....	2 by 10	2 by 4	2 by 4	2 by 4	1 by 4	2 by 4	
	Lower frame.....	1 by 6	1 by 4			1 by 4		1 by 4
	Strut.....	1 by 4	1 by 4			1 by 6		1 by 6
	Diagonal.....	1 by 6	1 by 6			1 by 6		1 by 6
24	Upper frame.....	(2)	2 by 6	2 by 4	2 by 4	1 by 4	2 by 4	
	Lower frame.....	(2)	1 by 4			1 by 4		2 by 4
	Strut.....	(2)	1 by 4			1 by 6		1 by 6
	Diagonal.....	(2)	1 by 6			2 by 6		2 by 6
28	Upper frame.....	(2)	2 by 6	2 by 4	2 by 4	1 by 4	2 by 4	
	Lower frame.....	(2)	1 by 4			1 by 4		1 by 4
	Strut.....	(2)	1 by 4			1 by 6		1 by 6
	Diagonal.....	(2)	1 by 6			2 by 8		2 by 6
32	Upper frame.....	(2)	2 by 8	2 by 6	2 by 4	2 by 6	2 by 4	
	Lower frame.....	(2)	1 by 4	2 by 4		2 by 4		2 by 4
	Strut.....	(2)	1 by 6	2 by 4		2 by 4		2 by 4
	Diagonal.....	(2)	1 by 6	2 by 4		2 by 6		2 by 6
36	Upper frame.....	(2)	2 by 8	2 by 6	2 by 4	2 by 6	2 by 4	
	Lower frame.....	(2)	1 by 4	2 by 4		2 by 4		2 by 4
	Strut.....	(2)	1 by 4	2 by 4		2 by 4		2 by 4
	Diagonal.....	(2)	1 by 6	2 by 4		2 by 4		2 by 4
40	Upper frame.....	(2)	2 by 10	2 by 6	2 by 4	2 by 6	2 by 4	
	Lower frame.....	(2)	1 by 6	2 by 4		2 by 4		2 by 4
	Strut.....	(2)	1 by 6	2 by 4		2 by 4		2 by 4
	Diagonal.....	(2)	1 by 6	2 by 4		2 by 6		2 by 4
44	Upper frame.....	(2)	2 by 10	2 by 8	2 by 4	2 by 6	2 by 4	
	Lower frame.....	(2)	2 by 4	2 by 4		2 by 4		2 by 4
	Strut.....	(2)	2 by 4	2 by 4		2 by 4		2 by 4
	Diagonal.....	(2)	2 by 4	2 by 4		2 by 6		2 by 4
48	Upper frame.....	(2)	2 by 12	2 by 8	2 by 4	2 by 6	2 by 4	
	Lower frame.....	(2)	2 by 6	2 by 4		2 by 4		2 by 4
	Strut.....	(2)	2 by 4	2 by 4		2 by 4		2 by 4
	Diagonal.....	(2)	2 by 4	2 by 4		2 by 6		2 by 4

See footnotes at end of table.

TABLE 31.—Panel member sizes for crates <sup>1</sup> designed for a net load of 10,000 pounds—Continued  
6-FOOT-WIDE CRATE

Length	Member	Crate height					
		2 feet	4 feet	6 feet	8 feet	10 feet	<sup>3</sup> 12 feet
<i>Ft.</i>		<i>In.</i>	<i>In.</i>	<i>In.</i>	<i>In.</i>	<i>In.</i>	<i>In.</i>
6	Upper frame.....	1 by 4	1 by 4	1 by 4	2 by 4	1 by 4	2 by 4
	Lower frame.....			1 by 4		1 by 4	
	Strut.....			1 by 6		1 by 6	
	Diagonal.....			1 by 6		1 by 6	
8	Upper frame.....	1 by 6	1 by 4	2 by 4	2 by 4	1 by 4	2 by 4
	Lower frame.....	1 by 4	1 by 4			1 by 4	
	Strut.....	1 by 4	1 by 4			1 by 6	
	Diagonal.....	1 by 6	1 by 6			1 by 6	
10	Upper frame.....	1 by 6	1 by 4	1 by 4	2 by 4	1 by 4	2 by 4
	Lower frame.....	1 by 4	1 by 4	1 by 4	2 by 4	1 by 4	
	Strut.....	1 by 4	1 by 4	1 by 6	2 by 4	1 by 6	
	Diagonal.....	1 by 6	1 by 6	1 by 6	2 by 6	1 by 6	
12	Upper frame.....	2 by 6	1 by 4	2 by 4	2 by 4	2 by 4	2 by 4
	Lower frame.....	1 by 4	1 by 4				
	Strut.....	1 by 4	1 by 4				
	Diagonal.....	1 by 6	1 by 6				
16	Upper frame.....	2 by 8	1 by 6	2 by 4	2 by 4	2 by 4	2 by 4
	Lower frame.....	1 by 4	1 by 4				
	Strut.....	1 by 4	1 by 4				
	Diagonal.....	1 by 6	1 by 6				
20	Upper frame.....	2 by 10	2 by 6	2 by 4	2 by 4	2 by 4	2 by 4
	Lower frame.....	1 by 6	1 by 4				
	Strut.....	1 by 4	1 by 4				
	Diagonal.....	1 by 6	1 by 6				
24	Upper frame.....	( <sup>2</sup> )	2 by 6	2 by 6	2 by 4	2 by 4	2 by 4
	Lower frame.....	( <sup>2</sup> )	1 by 4	2 by 4	2 by 4	2 by 4	2 by 4
	Strut.....	( <sup>2</sup> )	1 by 6	2 by 4	2 by 4	2 by 4	2 by 4
	Diagonal.....	( <sup>2</sup> )	1 by 6	2 by 4	2 by 6	2 by 6	2 by 6
28	Upper frame.....	( <sup>2</sup> )	2 by 6	2 by 6	2 by 4	2 by 4	2 by 4
	Lower frame.....	( <sup>2</sup> )	1 by 4	2 by 4	2 by 4	2 by 4	2 by 4
	Strut.....	( <sup>2</sup> )	1 by 4	2 by 4	2 by 4	2 by 4	2 by 4
	Diagonal.....	( <sup>2</sup> )	1 by 6	2 by 4	2 by 6	2 by 6	2 by 6
32	Upper frame.....	( <sup>2</sup> )	2 by 8	2 by 6	2 by 6	2 by 4	2 by 4
	Lower frame.....	( <sup>2</sup> )	1 by 4	2 by 4	2 by 4	2 by 4	2 by 4
	Strut.....	( <sup>2</sup> )	1 by 6	2 by 4	2 by 4	2 by 4	2 by 4
	Diagonal.....	( <sup>2</sup> )	1 by 6	2 by 4	2 by 6	2 by 6	2 by 6
36	Upper frame.....	( <sup>2</sup> )	2 by 8	2 by 8	2 by 6	2 by 4	2 by 4
	Lower frame.....	( <sup>2</sup> )	2 by 4	2 by 4	2 by 4	2 by 4	2 by 4
	Strut.....	( <sup>2</sup> )	2 by 4	2 by 4	2 by 4	2 by 4	2 by 4
	Diagonal.....	( <sup>2</sup> )	2 by 4	2 by 4	2 by 6	2 by 6	2 by 6
40	Upper frame.....	( <sup>2</sup> )	2 by 10	2 by 8	2 by 6	2 by 6	2 by 4
	Lower frame.....	( <sup>2</sup> )	2 by 4	2 by 4	2 by 4	2 by 4	2 by 4
	Strut.....	( <sup>2</sup> )	2 by 4	2 by 4	2 by 4	2 by 4	2 by 4
	Diagonal.....	( <sup>2</sup> )	2 by 4	2 by 4	2 by 6	2 by 6	2 by 6
44	Upper frame.....	( <sup>2</sup> )	2 by 12	2 by 8	2 by 8	2 by 6	2 by 6
	Lower frame.....	( <sup>2</sup> )	2 by 4	2 by 4	2 by 4	2 by 4	2 by 4
	Strut.....	( <sup>2</sup> )	2 by 4	2 by 4	2 by 4	2 by 4	2 by 4
	Diagonal.....	( <sup>2</sup> )	2 by 4	2 by 6	2 by 6	2 by 6	2 by 6
48	Upper frame.....	( <sup>2</sup> )	2 by 12	2 by 10	2 by 8	2 by 6	2 by 6
	Lower frame.....	( <sup>2</sup> )	2 by 6	2 by 4	2 by 4	2 by 4	2 by 4
	Strut.....	( <sup>2</sup> )	2 by 4	2 by 4	2 by 4	2 by 4	2 by 4
	Diagonal.....	( <sup>2</sup> )	2 by 4	2 by 6	2 by 6	2 by 6	2 by 6

See footnotes at end of table.

TABLE 31.—Panel member sizes for crates <sup>1</sup> designed for a net load of 10,000 pounds—Continued  
&FOOT-WIDE CRATE

Length	Member	Crate height					
		2 feet	4 feet	6 feet	8 feet	*10 feet	12 feet
<i>Ft.</i>		<i>In.</i>	<i>In.</i>	<i>In.</i>	<i>In.</i>	<i>In.</i>	<i>In.</i>
6	Upper frame.....	1 by 4	1 by 4	2 by 4	2 by 4	1 by 4	2 by 4
	Lower frame.....		1 by 4			1 by 4	
	Strut.....		1 by 4			1 by 4	
	Diagonal.....		1 by 4			1 by 4	
8	Upper frame.....	1 by 6	1 by 4	2 by 4	2 by 4	1 by 4	2 by 4
	Lower frame.....	1 by 4	1 by 4			1 by 4	
	Strut.....	1 by 4	1 by 6			1 by 6	
	Diagonal.....	1 by 6	1 by 6			1 by 6	
10	Upper frame.....	1 by 6	1 by 4	1 by 4	2 by 4	1 by 4	2 by 4
	Lower frame.....	1 by 4	1 by 4	1 by 4	2 by 4	1 by 4	
	Strut.....	1 by 4	1 by 4	1 by 6	2 by 4	1 by 6	
	Diagonal.....	1 by 6	1 by 6	1 by 6	2 by 6	1 by 6	
12	Upper frame.....	2 by 6	1 by 4	2 by 4	2 by 4	2 by 4	2 by 4
	Lower frame.....	1 by 4	1 by 4			2 by 4	
	Strut.....	1 by 4	1 by 4			2 by 4	
	Diagonal.....	1 by 6	1 by 6			2 by 4	
16	Upper frame.....	2 by 8	1 by 6	2 by 4	2 by 4	2 by 4	2 by 4
	Lower frame.....	1 by 4	1 by 4			2 by 4	
	Strut.....	1 by 4	1 by 6			2 by 4	
	Diagonal.....	1 by 6	1 by 6			2 by 6	
20	Upper frame.....	2 by 10	2 by 6	2 by 4	2 by 4	2 by 4	2 by 4
	Lower frame.....	1 by 6	1 by 4			2 by 4	
	Strut.....	1 by 4	1 by 4			2 by 4	
	Diagonal.....	1 by 6	1 by 6			2 by 6	
24	Upper frame.....	( <sup>2</sup> )	2 by 6	2 by 6	2 by 4	2 by 4	2 by 4
	Lower frame.....	( <sup>2</sup> )	1 by 4	2 by 4	2 by 4	2 by 4	2 by 4
	Strut.....	( <sup>2</sup> )	1 by 6	2 by 4	2 by 4	2 by 6	2 by 6
	Diagonal.....	( <sup>2</sup> )	1 by 6	2 by 4	2 by 6	2 by 6	2 by 6
28	Upper frame.....	( <sup>2</sup> )	2 by 8	2 by 6	2 by 6	2 by 4	2 by 4
	Lower frame.....	( <sup>2</sup> )	2 by 4	2 by 4	2 by 4	2 by 4	2 by 4
	Strut.....	( <sup>2</sup> )	2 by 4	2 by 4	2 by 4	2 by 4	2 by 4
	Diagonal.....	( <sup>2</sup> )	2 by 4	2 by 4	2 by 6	2 by 6	2 by 6
32	Upper frame.....	( <sup>2</sup> )	2 by 10	2 by 6	2 by 6	2 by 4	2 by 4
	Lower frame.....	( <sup>2</sup> )	2 by 4	2 by 4	2 by 4	2 by 4	2 by 4
	Strut.....	( <sup>2</sup> )	2 by 4	2 by 4	2 by 4	2 by 4	2 by 4
	Diagonal.....	( <sup>2</sup> )	2 by 4	2 by 4	2 by 6	2 by 6	2 by 6
36	Upper frame.....	( <sup>2</sup> )	2 by 10	2 by 8	2 by 6	2 by 6	2 by 4
	Lower frame.....	( <sup>2</sup> )	2 by 4	2 by 4	2 by 4	2 by 4	2 by 4
	Strut.....	( <sup>2</sup> )	2 by 4	2 by 4	2 by 4	2 by 4	2 by 4
	Diagonal.....	( <sup>2</sup> )	2 by 4	2 by 4	2 by 6	2 by 6	2 by 6
40	Upper frame.....	( <sup>2</sup> )	2 by 12	2 by 8	2 by 6	2 by 6	2 by 4
	Lower frame.....	( <sup>2</sup> )	2 by 4	2 by 4	2 by 4	2 by 4	2 by 4
	Strut.....	( <sup>2</sup> )	2 by 4	2 by 4	2 by 4	2 by 4	2 by 4
	Diagonal.....	( <sup>2</sup> )	2 by 4	2 by 4	2 by 6	2 by 6	2 by 6
44	Upper frame.....	( <sup>2</sup> )	2 by 12	2 by 8	2 by 8	2 by 6	2 by 6
	Lower frame.....	( <sup>2</sup> )	2 by 6	2 by 4	2 by 4	2 by 4	2 by 4
	Strut.....	( <sup>2</sup> )	2 by 4	2 by 4	2 by 4	2 by 4	2 by 4
	Diagonal.....	( <sup>2</sup> )	2 by 6	2 by 6	2 by 6	2 by 6	2 by 6
48	Upper frame.....	( <sup>2</sup> )	2 by 12	2 by 10	2 by 8	2 by 6	2 by 6
	Lower frame.....	( <sup>2</sup> )	2 by 6	2 by 4	2 by 4	2 by 4	2 by 4
	Strut.....	( <sup>2</sup> )	2 by 4	2 by 4	2 by 4	2 by 4	2 by 6
	Diagonal.....	( <sup>2</sup> )	2 by 4	2 by 4	2 by 6	2 by 6	2 by 6

<sup>1</sup> See footnotes at end of table.

TABLE 31 .—Panel member sizes for crates <sup>1</sup> designed for a net load of 10,000 pounds—Continued  
10-FOOT-WIDE CRATE

Length	Member	Crate height					
		2 feet	4 feet	6 feet	8 feet	10 feet	12 feet
<i>Ft.</i>		<i>In.</i>	<i>In.</i>	<i>In.</i>	<i>In.</i>	<i>In.</i>	<i>In.</i>
6	Upper frame.....	1 by 4	1 by 4	2 by 4	2 by 4	2 by 4	2 by 4
	Lower frame.....		1 by 4				
	Strut.....		1 by 6				
	Diagonal.....		1 by 6				
8	Upper frame.....	1 by 6	1 by 4	2 by 4	2 by 4	2 by 4	2 by 4
	Lower frame.....	1 by 4	1 by 4				
	Strut.....	1 by 4	1 by 6				
	Diagonal.....	1 by 6	1 by 6				
10	Upper frame.....	1 by 6	1 by 4	2 by 4	2 by 4	2 by 4	2 by 4
	Lower frame.....	1 by 4	1 by 4				
	Strut.....	1 by 4	1 by 4				
	Diagonal.....	1 by 6	1 by 6				
12	Upper frame.....	2 by 6	1 by 4	2 by 4	2 by 4	2 by 4	2 by 4
	Lower frame.....	1 by 4	1 by 4				
	Strut.....	1 by 4	1 by 4				
	Diagonal.....	1 by 6	1 by 6				
16	Upper frame.....	2 by 8	1 by 6	2 by 4	2 by 4	2 by 4	2 by 4
	Lower frame.....	1 by 4	1 by 4				
	Strut.....	1 by 4	1 by 6				
	Diagonal.....	1 by 6	1 by 6				
20	Upper frame.....	2 by 10	2 by 6	2 by 4	2 by 4	2 by 4	2 by 4
	Lower frame.....	1 by 6	2 by 4				
	Strut.....	1 by 4	2 by 4				
	Diagonal.....	1 by 6	2 by 4				
24	Upper frame.....	( <sup>2</sup> )	2 by 8	2 by 6	2 by 4	2 by 4	2 by 4
	Lower frame.....	( <sup>2</sup> )	2 by 4				
	Strut.....	( <sup>2</sup> )	2 by 4				
	Diagonal.....	( <sup>2</sup> )	2 by 4				
28	Upper frame.....	( <sup>2</sup> )	2 by 8	2 by 6	2 by 6	2 by 4	2 by 4
	Lower frame.....	( <sup>2</sup> )	2 by 4				
	Strut.....	( <sup>2</sup> )	2 by 4				
	Diagonal.....	( <sup>2</sup> )	2 by 4				
32	Upper frame.....	( <sup>2</sup> )	2 by 10	2 by 6	2 by 6	2 by 4	2 by 4
	Lower frame.....	( <sup>2</sup> )	2 by 4				
	Strut.....	( <sup>2</sup> )	2 by 4				
	Diagonal.....	( <sup>2</sup> )	2 by 4				
36	Upper frame.....	( <sup>2</sup> )	2 by 10	2 by 8	2 by 6	2 by 6	2 by 6
	Lower frame.....	( <sup>2</sup> )	2 by 4				
	Strut.....	( <sup>2</sup> )	2 by 4				
	Diagonal.....	( <sup>2</sup> )	2 by 4				
40	Upper frame.....	( <sup>2</sup> )	2 by 12	2 by 8	2 by 6	2 by 6	2 by 6
	Lower frame.....	( <sup>2</sup> )	2 by 6				
	Strut.....	( <sup>2</sup> )	2 by 4				
	Diagonal.....	( <sup>2</sup> )	2 by 4				
44	Upper frame.....	( <sup>2</sup> )	2 by 12	2 by 10	2 by 8	2 by 6	2 by 6
	Lower frame.....	( <sup>2</sup> )	2 by 6				
	Strut.....	( <sup>2</sup> )	2 by 4				
	Diagonal.....	( <sup>2</sup> )	2 by 6				
48	Upper frame.....	( <sup>2</sup> )	2 by 12	2 by 10	2 by 10	2 by 8	2 by 8
	Lower frame.....	( <sup>2</sup> )	2 by 8				
	Strut.....	( <sup>2</sup> )	2 by 4				
	Diagonal.....	( <sup>2</sup> )	2 by 4				

<sup>1</sup> With horizontal joist supports, except as indicated.

<sup>2</sup> Crates require special design.

<sup>3</sup> Crates require 2 by 4 vertical joist supports when struts are 1 inch thick.

TABLE 32.—Panel member sizes for crates <sup>1</sup> designed for a net load of 15,000 pounds  
4-FOOT-WIDE CRATE

Length	Member	Crate height					
		4 feet	6 feet	8 feet	10 feet	12 feet	
<i>Ft.</i>		<i>In.</i>	<i>In.</i>	<i>In.</i>	<i>In.</i>	<i>In.</i>	
6	Upper frame.....	2 by 4	2 by 4	2 by 4	2 by 4	2 by 4	
	Lower frame.....			2 by 4	2 by 4	2 by 4	
	Strut.....			2 by 4	2 by 4	2 by 4	
	Diagonal.....			2 by 4 <sup>2</sup>	2 by 6	2 by 6	
8	Upper frame.....	2 by 4	2 by 4	2 by 4	2 by 4	2 by 4	
	Lower frame.....			2 by 4		2 by 4	
	Strut.....			2 by 4		2 by 4	
	Diagonal.....			2 by 4 <sup>2</sup>		2 by 6	
10	Upper frame.....	2 by 4	2 by 4	2 by 4	2 by 4	2 by 4	
	Lower frame.....			2 by 4			2 by 4
	Strut.....			2 by 4			2 by 4
	Diagonal.....			2 by 6			2 by 4 <sup>2</sup>
12	Upper frame.....	2 by 4	2 by 4	2 by 4	2 by 4	2 by 4	
	Lower frame.....			2 by 4		2 by 4	
	Strut.....			2 by 4		2 by 4	
	Diagonal.....			2 by 6		2 by 6	
16	Upper frame.....	2 by 4	2 by 4	2 by 4	2 by 4	2 by 4	
	Lower frame.....			2 by 4		2 by 4	
	Strut.....			2 by 4		2 by 4	
	Diagonal.....			2 by 6		2 by 6	
20	Upper frame.....	2 by 6	2 by 4	2 by 4	2 by 4	2 by 4	
	Lower frame.....	2 by 4	2 by 4	2 by 4	2 by 4	2 by 4	
	Strut.....	2 by 4	2 by 4	2 by 4	2 by 6	2 by 6	
	Diagonal.....	2 by 4	2 by 6	2 by 6	2 by 6	2 by 6	
24	Upper frame.....	2 by 6 <sup>3</sup>	2 by 4 <sup>2</sup>	2 by 4	2 by 4	2 by 4	
	Lower frame.....	2 by 4	2 by 4	2 by 4	2 by 4	2 by 4	
	Strut.....	2 by 4	2 by 4	2 by 4	2 by 6	2 by 6	
	Diagonal.....	2 by 4	2 by 6	2 by 6	2 by 6	2 by 6	
28	Upper frame.....	2 by 6 <sup>3</sup>	2 by 6	2 by 4 <sup>2</sup>	2 by 4	2 by 4	
	Lower frame.....	2 by 4	2 by 4	2 by 4	2 by 4	2 by 4	
	Strut.....	2 by 4	2 by 4	2 by 4	2 by 4	2 by 4	
	Diagonal.....	2 by 4	2 by 4 <sup>2</sup>	2 by 6	2 by 6	2 by 6	
32	Upper frame.....	2 by 8 <sup>3</sup>	2 by 6	2 by 6	2 by 4	2 by 4	
	Lower frame.....	2 by 4 <sup>2</sup>	2 by 4	2 by 4	2 by 4	2 by 4	
	Strut.....	2 by 4	2 by 4	2 by 4	2 by 4	2 by 4	
	Diagonal.....	2 by 4 <sup>2</sup>	2 by 6	2 by 6	2 by 6	2 by 6	

See footnotes at end of table.

TABLE 32.—Panel member sizes for crates <sup>1</sup> designed for a net load of 15,000 pounds—Continued  
6-FOOT-WIDE CRATE

Length	Member	Crate height				
		4 feet	6 feet	8 feet	10 feet	12 feet
<i>Ft.</i>		<i>In.</i>	<i>In.</i>	<i>In.</i>	<i>In.</i>	<i>In.</i>
6	Upper frame.....	2 by 4	2 by 4	2 by 4	2 by 4	2 by 4
	Lower frame.....			2 by 4	2 by 4	2 by 4
	Strut.....			2 by 4	2 by 4	2 by 4
	Diagonal.....			2 by 4 <sup>2</sup>	2 by 6	2 by 6
8	Upper frame.....	2 by 4	2 by 4	2 by 4	2 by 4	2 by 4
	Lower frame.....			2 by 4	2 by 4	2 by 4
	Strut.....			2 by 4	2 by 4	2 by 4
	Diagonal.....			2 by 4 <sup>2</sup>	2 by 6	2 by 6
10	Upper frame.....	2 by 4	2 by 4	2 by 4	2 by 4	2 by 4
	Lower frame.....			2 by 4	2 by 4	2 by 4
	Strut.....			2 by 4	2 by 4 <sup>2</sup>	2 by 6
	Diagonal.....			2 by 6	2 by 6	2 by 6
12	Upper frame.....	2 by 4	2 by 4	2 by 4	2 by 4	2 by 4
	Lower frame.....			2 by 4	2 by 4	2 by 4
	Strut.....			2 by 4	2 by 6	2 by 6
	Diagonal.....			2 by 6	2 by 6	2 by 6
16	Upper frame.....	2 by 4	2 by 4	2 by 4	2 by 4	2 by 4
	Lower frame.....			2 by 4	2 by 6	2 by 6
	Strut.....			2 by 6	2 by 6	2 by 6
	Diagonal.....			2 by 6	2 by 6	2 by 6
20	Upper frame.....	2 by 6	2 by 4	2 by 4	2 by 4	2 by 4
	Lower frame.....	2 by 4	2 by 4	2 by 4	2 by 4	2 by 4
	Strut.....	2 by 4	2 by 4	2 by 4	2 by 6	2 by 6
	Diagonal.....	2 by 6	2 by 6	2 by 6	2 by 6	2 by 6
24	Upper frame.....	2 by 6 <sup>3</sup>	2 by 6	2 by 4	2 by 4	2 by 4
	Lower frame.....	2 by 4	2 by 4	2 by 4	2 by 4	2 by 4
	Strut.....	2 by 4	2 by 4	2 by 4	2 by 6	2 by 6
	Diagonal.....	2 by 6	2 by 6	2 by 6	2 by 6	2 by 6
28	Upper frame.....	2 by 6 <sup>3</sup>	2 by 6	2 by 6	2 by 4	2 by 4
	Lower frame.....	2 by 4	2 by 4	2 by 4	2 by 4	2 by 4
	Strut.....	2 by 4	2 by 4	2 by 4 <sup>2</sup>	2 by 4	2 by 4
	Diagonal.....	2 by 6	2 by 6	2 by 6	2 by 6	2 by 6
32	Upper frame.....	2 by 8 <sup>3</sup>	2 by 6 <sup>2</sup>	2 by 6 <sup>2</sup>	2 by 4	2 by 4
	Lower frame.....	2 by 4 <sup>2</sup>	2 by 4	2 by 4	2 by 4	2 by 4
	Strut.....	2 by 4	2 by 4	2 by 4 <sup>2</sup>	2 by 4	2 by 4
	Diagonal.....	2 by 6	2 by 6	2 by 6	2 by 6	2 by 6

See footnotes at end of table.

TABLE 32.—Panel member sizes for crates <sup>1</sup> designed for a net load of 15,000 pounds—Continued  
8-FOOT-WIDE CRATE

Length	Member	Crate height				
		4 feet	6 feet	8 feet	10 feet	12 feet
<i>Ft.</i>		<i>In.</i>	<i>In.</i>	<i>In.</i>	<i>In.</i>	<i>In.</i>
6	Upper frame.....	2 by 4	2 by 4	2 by 4	2 by 4	2 by 4
	Lower frame.....		2 by 4	2 by 4	2 by 4	2 by 4
	Strut.....		2 by 4	2 by 4	2 by 4	2 by 4
8	Upper frame.....	2 by 4	2 by 4 <sup>2</sup>	2 by 4 <sup>2</sup>	2 by 6	2 by 6
	Lower frame.....		2 by 4	2 by 4	2 by 4	2 by 4
	Strut.....		2 by 4	2 by 4 <sup>2</sup>	2 by 6	2 by 6
10	Upper frame.....	2 by 4	2 by 4	2 by 4	2 by 4	2 by 4
	Lower frame.....		2 by 4	2 by 4	2 by 4	2 by 4
	Strut.....		2 by 4	2 by 6	2 by 6	2 by 6
12	Upper frame.....	2 by 4	2 by 6	2 by 6	2 by 6	2 by 6
	Lower frame.....		2 by 4	2 by 4	2 by 4	2 by 4
	Strut.....		2 by 6	2 by 6	2 by 6	2 by 6
16	Upper frame.....	2 by 6	2 by 4	2 by 4	2 by 4	2 by 4
	Lower frame.....	2 by 4	2 by 4	2 by 4	2 by 4	2 by 4
	Strut.....	2 by 4	2 by 4	2 by 6	2 by 6	2 by 6
20	Upper frame.....	2 by 6	2 by 4	2 by 4	2 by 4	2 by 4
	Lower frame.....	2 by 4	2 by 4	2 by 4	2 by 4	2 by 4
	Strut.....	2 by 4	2 by 4	2 by 4	2 by 6	2 by 6
24	Upper frame.....	2 by 6 <sup>3</sup>	2 by 6	2 by 6	2 by 6	2 by 6
	Lower frame.....	2 by 4	2 by 4	2 by 4	2 by 4	2 by 4
	Strut.....	2 by 4	2 by 4 <sup>2</sup>	2 by 4	2 by 6	2 by 6
28	Upper frame.....	2 by 6	2 by 6	2 by 6	2 by 6	2 by 6
	Lower frame.....	2 by 8 <sup>2</sup>	2 by 6	2 by 6	2 by 6	2 by 4
	Strut.....	2 by 4	2 by 4	2 by 4	2 by 4	2 by 4
32	Upper frame.....	2 by 4	2 by 4	2 by 4 <sup>2</sup>	2 by 4	2 by 4
	Lower frame.....	2 by 6 <sup>3</sup>	2 by 6 <sup>2</sup>	2 by 6	2 by 6	2 by 4 <sup>2</sup>
	Strut.....	2 by 4 <sup>2</sup>	2 by 4	2 by 4	2 by 4	2 by 4
	Diagonal.....	2 by 6	2 by 6	2 by 6	2 by 6	2 by 8

See footnotes at end of table.

TABLE 32.—Panel member sizes for crates <sup>1</sup> designed for a net load of 15,000 pounds—Continued  
10-FOOT-WIDE CRATE

Length	Member	Crate height				
		4 feet	6 feet	8 feet	10 feet	12 feet
<i>Ft.</i>		<i>In.</i>	<i>In.</i>	<i>In.</i>	<i>In.</i>	<i>In.</i>
6	Upper frame.....	2 by 4	2 by 4	2 by 4	2 by 4	2 by 4
	Lower frame.....		2 by 4	2 by 4	2 by 4	2 by 4
	Strut.....		2 by 4	2 by 6	2 by 6	2 by 6
	Diagonal.....		2 by 4 <sup>2</sup>	2 by 4 <sup>2</sup>	2 by 6	2 by 6
8	Upper frame.....	2 by 4	2 by 4	2 by 4	2 by 4	2 by 4
	Lower frame.....		2 by 4	2 by 4	2 by 4	2 by 4
	Strut.....		2 by 4 <sup>2</sup>	2 by 6	2 by 6	2 by 6
	Diagonal.....		2 by 4 <sup>2</sup>	2 by 6	2 by 4 <sup>2</sup>	2 by 6
10	Upper frame.....	2 by 4	2 by 4	2 by 4	2 by 4	2 by 4
	Lower frame.....		2 by 4	2 by 4	2 by 4	2 by 4
	Strut.....		2 by 6	2 by 6	2 by 6	2 by 6
	Diagonal.....		2 by 6	2 by 6	2 by 6	2 by 6
12	Upper frame.....	2 by 4	2 by 4	2 by 4	2 by 4	2 by 4
	Lower frame.....	2 by 4	2 by 4	2 by 4	2 by 4	2 by 4
	Strut.....	2 by 4	2 by 6	2 by 6	2 by 6	2 by 6
	Diagonal.....	2 by 4 <sup>2</sup>	2 by 6	2 by 6	2 by 6	2 by 6
16	Upper frame.....	2 by 4	2 by 4	2 by 4	2 by 4	2 by 4
	Lower frame.....	2 by 4	2 by 4	2 by 4	2 by 4	2 by 4
	Strut.....	2 by 4	2 by 4	2 by 6	2 by 6	2 by 6
	Diagonal.....	2 by 6	2 by 6	2 by 6	2 by 6	2 by 6
20	Upper frame.....	2 by 6	2 by 4	2 by 4	2 by 4	2 by 4
	Lower frame.....	2 by 4	2 by 4	2 by 4	2 by 4	2 by 4
	Strut.....	2 by 4	2 by 4	2 by 4	2 by 6	2 by 6
	Diagonal.....	2 by 6	2 by 6	2 by 6	2 by 6	2 by 6
24	Upper frame.....	2 by 6 <sup>2</sup>	2 by 6	2 by 6	2 by 6	2 by 6
	Lower frame.....	2 by 4	2 by 4	2 by 4	2 by 4	2 by 4
	Strut.....	2 by 4	2 by 4 <sup>2</sup>	2 by 4	2 by 6	2 by 6
	Diagonal.....	2 by 6	2 by 6	2 by 6	2 by 6	2 by 6
28	Upper frame.....	2 by 8 <sup>2</sup>	2 by 6	2 by 6	2 by 6	2 by 6
	Lower frame.....	2 by 4	2 by 4	2 by 4	2 by 4	2 by 4
	Strut.....	2 by 4	2 by 4	2 by 4 <sup>2</sup>	2 by 4	2 by 4
	Diagonal.....	2 by 6	2 by 6	2 by 6	2 by 6	2 by 8
32	Upper frame.....	2 by 8 <sup>2</sup>	2 by 6 <sup>2</sup>	2 by 6 <sup>2</sup>	2 by 6	2 by 6
	Lower frame.....	2 by 4 <sup>2</sup>	2 by 4	2 by 4	2 by 4	2 by 4
	Strut.....	2 by 4 <sup>2</sup>	2 by 4	2 by 4 <sup>2</sup>	2 by 4	2 by 4
	Diagonal.....	2 by 6	2 by 6	2 by 8	2 by 8	2 by 8

<sup>1</sup> Sizes are for uniform loads but apply also to concentrated loads except as indicated.

<sup>2</sup> For concentrated loads, increase the member size to the next larger size, as a 2 by 4 to a 2 by 6.

<sup>3</sup> For concentrated loads, increase the member size to the second larger size, as a 2 by 6 to a 2 by 10.

TABLE 33.—Panel member sizes for crates <sup>1</sup> designed for a net load of 20,000 pounds  
4-FOOT-WIDE CRATE

Length	Member	Crate height				
		4 feet	6 feet	8 feet	10 feet	12 feet
Fl.		<i>In.</i>	<i>In.</i>	<i>In.</i>	<i>In.</i>	<i>In.</i>
6	Upper frame.....	2 by 4	2 by 4	2 by 4	2 by 4	2 by 4
	Lower frame.....	2 by 4	2 by 4	2 by 4	2 by 4	2 by 4
	Strut.....	2 by 6	2 by 6	2 by 6	2 by 6	2 by 6
	Diagonal.....	2 by 6	2 by 6	2 by 6	2 by 6	2 by 6
8	Upper frame.....	2 by 4 <sup>2</sup>	2 by 4 <sup>2</sup>	2 by 4	2 by 4	2 by 4
	Lower frame.....	2 by 4	2 by 4	2 by 4	2 by 4	2 by 4
	Strut.....	2 by 6	2 by 6	2 by 6	2 by 6	2 by 6
	Diagonal.....	2 by 6	2 by 6	2 by 6	2 by 6	2 by 6 <sup>2</sup>
10	Upper frame.....	2 by 6	2 by 6	2 by 6	2 by 4	2 by 4
	Lower frame.....	2 by 4	2 by 4	2 by 4	2 by 4	2 by 4
	Strut.....	2 by 4	2 by 6	2 by 6	2 by 6	2 by 6
	Diagonal.....	2 by 6	2 by 6	2 by 8	2 by 6	2 by 6
12	Upper frame.....	2 by 6	2 by 6	2 by 6	2 by 4	2 by 4
	Lower frame.....	2 by 4	2 by 4	2 by 4	2 by 4	2 by 4
	Strut.....	2 by 4	2 by 6	2 by 6	2 by 6	2 by 6
	Diagonal.....	2 by 6	2 by 6	2 by 6	2 by 6	2 by 6
16	Upper frame.....	2 by 6	2 by 6	2 by 6	2 by 6	2 by 4
	Lower frame.....	2 by 4	2 by 4	2 by 4	2 by 4	2 by 4
	Strut.....	2 by 4 <sup>2</sup>	2 by 4	2 by 6	2 by 6	2 by 6
	Diagonal.....	2 by 6	2 by 6	2 by 6	2 by 6	2 by 6
20	Upper frame.....	2 by 6 <sup>2</sup>	2 by 6	2 by 6	2 by 6	2 by 6
	Lower frame.....	2 by 4	2 by 4	2 by 4	2 by 4	2 by 4
	Strut.....	2 by 4	2 by 4	2 by 4	2 by 6	2 by 6
	Diagonal.....	2 by 6	2 by 6	2 by 6	2 by 6	2 by 6
24	Upper frame.....	2 by 8 <sup>3</sup>	2 by 6 <sup>2</sup>	2 by 6	2 by 6	2 by 6
	Lower frame.....	2 by 4	2 by 4	2 by 4	2 by 4	2 by 4
	Strut.....	2 by 4 <sup>2</sup>	2 by 4 <sup>2</sup>	2 by 4	2 by 6	2 by 6
	Diagonal.....	2 by 6	2 by 6	2 by 8	2 by 6	2 by 6
28	Upper frame.....	2 by 8 <sup>3</sup>	2 by 6 <sup>2</sup>	2 by 6 <sup>2</sup>	2 by 6	2 by 6
	Lower frame.....	2 by 4	2 by 4	2 by 4	2 by 4	2 by 4
	Strut.....	2 by 4	2 by 4	2 by 4 <sup>2</sup>	2 by 4	2 by 4
	Diagonal.....	2 by 6	2 by 6	2 by 6	2 by 6	2 by 6
32	Upper frame.....	2 by 10 <sup>4</sup>	2 by 6 <sup>2</sup>	2 by 6 <sup>2</sup>	2 by 6	2 by 6
	Lower frame.....	2 by 4 <sup>4</sup>	2 by 4	2 by 4	2 by 4	2 by 4
	Strut.....	2 by 4 <sup>4</sup>	2 by 4	2 by 4 <sup>2</sup>	2 by 4	2 by 4
	Diagonal.....	2 by 6 <sup>4</sup>	2 by 6	2 by 8	2 by 6	2 by 6 <sup>2</sup>

See footnotes at end of table.

TABLE 33.—Panel member sizes for crates <sup>1</sup> designed for a net load of 20,000 pounds—Continued

6-FOOT-WIDE CRATE

Length	Member	Crate height				
		4 feet	6 feet	8 feet	10 feet	12 feet
6	Upper frame.....	<i>In.</i> 2 by 4	<i>In.</i> 2 by 4	<i>In.</i> 2 by 4	<i>In.</i> 2 by 4	<i>In.</i> 2 by 4
	Lower frame.....	2 by 4	2 by 4	2 by 4	2 by 4	2 by 4
	Strut.....	2 by 6	2 by 6	2 by 6	2 by 6	2 by 6
	Diagonal.....	2 by 6	2 by 6	2 by 6	2 by 6	2 by 6
8	Upper frame.....	2 by 4 <sup>2</sup>	2 by 4 <sup>2</sup>	2 by 4	2 by 4	2 by 4
	Lower frame.....	2 by 4	2 by 4	2 by 4	2 by 4	2 by 4
	Strut.....	2 by 6	2 by 6	2 by 6	2 by 6	2 by 6
	Diagonal.....	2 by 6	2 by 6	2 by 6	2 by 6	2 by 8
10	Upper frame.....	2 by 6	2 by 6	2 by 6	2 by 4	2 by 4
	Lower frame.....	2 by 4	2 by 4	2 by 4	2 by 4	2 by 4
	Strut.....	2 by 4	2 by 6	2 by 6	2 by 6	2 by 6
	Diagonal.....	2 by 6	2 by 6	2 by 8	2 by 6	2 by 6
12	Upper frame.....	2 by 6	2 by 6	2 by 6	2 by 4	2 by 4
	Lower frame.....	2 by 4	2 by 4	2 by 4	2 by 4	2 by 4
	Strut.....	2 by 4	2 by 6	2 by 6	2 by 6	2 by 6
	Diagonal.....	2 by 6	2 by 6	2 by 6	2 by 6	2 by 6
16	Upper frame.....	2 by 6	2 by 6	2 by 6	2 by 6	2 by 4
	Lower frame.....	2 by 4	2 by 4	2 by 4	2 by 4	2 by 4
	Strut.....	2 by 4 <sup>2</sup>	2 by 4	2 by 6	2 by 6	2 by 6
	Diagonal.....	2 by 6	2 by 6	2 by 8	2 by 6	2 by 6
20	Upper frame.....	2 by 6 <sup>2</sup>	2 by 6	2 by 6	2 by 6	2 by 6
	Lower frame.....	2 by 4	2 by 4	2 by 4	2 by 4	2 by 4
	Strut.....	2 by 4	2 by 4	2 by 4	2 by 6	2 by 6
	Diagonal.....	2 by 6	2 by 6	2 by 6	2 by 6	2 by 6
24	Upper frame.....	2 by 8 <sup>3</sup>	2 by 6 <sup>2</sup>	2 by 6	2 by 6	2 by 6
	Lower frame.....	2 by 4 <sup>2</sup>	2 by 4	2 by 4	2 by 4	2 by 4
	Strut.....	2 by 4 <sup>2</sup>	2 by 4 <sup>2</sup>	2 by 4	2 by 6	2 by 6
	Diagonal.....	2 by 6	2 by 6	2 by 8	2 by 8	2 by 6 <sup>2</sup>
28	Upper frame.....	2 by 8 <sup>3</sup>	2 by 6 <sup>2</sup>	2 by 6 <sup>2</sup>	2 by 6	2 by 6
	Lower frame.....	2 by 4 <sup>2</sup>	2 by 4	2 by 4	2 by 4	2 by 4
	Strut.....	2 by 4	2 by 4	2 by 4 <sup>2</sup>	2 by 4	2 by 4
	Diagonal.....	2 by 6	2 by 6	2 by 8	2 by 8	2 by 8
32	Upper frame.....	2 by 10 <sup>4</sup>	2 by 8	2 by 6 <sup>2</sup>	2 by 6	2 by 6
	Lower frame.....	2 by 4 <sup>4</sup>	2 by 4	2 by 4	2 by 4	2 by 4
	Strut.....	2 by 4 <sup>4</sup>	2 by 4	2 by 4 <sup>2</sup>	2 by 4	2 by 4
	Diagonal.....	2 by 6 <sup>4</sup>	2 by 6	2 by 8	2 by 8	2 by 8

See footnotes at end of table.

TABLE 33.—Panel member sizes for crates <sup>1</sup> designed for a net load of 20,000 pounds—Continued  
8-FOOT-WIDE CRATE

Length	Member	Crate height				
		4 feet	6 feet	8 feet	10 feet	12 feet
<i>Ft.</i>		<i>In.</i>	<i>In.</i>	<i>In.</i>	<i>In.</i>	<i>In.</i>
6	Upper frame.....	2 by 4	2 by 4	2 by 4	2 by 4	2 by 4
	Lower frame.....	2 by 4	2 by 4	2 by 4	2 by 4	2 by 4
	Strut.....	2 by 6	2 by 6	2 by 6	2 by 6	2 by 6
	Diagonal.....	2 by 6	2 by 6	2 by 6	2 by 6	2 by 6
8	Upper frame.....	2 by 6	2 by 6	2 by 4	2 by 4	2 by 4
	Lower frame.....	2 by 4	2 by 4	2 by 4	2 by 4	2 by 4
	Strut.....	2 by 6	2 by 6	2 by 6	2 by 6	2 by 6
	Diagonal.....	2 by 6	2 by 6 <sup>2</sup>	2 by 8	2 by 6	2 by 8
10	Upper frame.....	2 by 6	2 by 6	2 by 6	2 by 4	2 by 4
	Lower frame.....	2 by 4	2 by 4	2 by 4	2 by 4	2 by 4
	Strut.....	2 by 4	2 by 6	2 by 6	2 by 6	2 by 6
	Diagonal.....	2 by 6	2 by 6	2 by 8	2 by 6	2 by 6
12	Upper frame.....	2 by 6	2 by 6	2 by 6	2 by 6	2 by 4
	Lower frame.....	2 by 4	2 by 4	2 by 4	2 by 4	2 by 4
	Strut.....	2 by 4	2 by 6	2 by 6	2 by 6	2 by 6
	Diagonal.....	2 by 6	2 by 6	2 by 6	2 by 6 <sup>2</sup>	2 by 6
16	Upper frame.....	2 by 6	2 by 6	2 by 6	2 by 6	2 by 4
	Lower frame.....	2 by 4	2 by 4	2 by 4	2 by 4	2 by 4
	Strut.....	2 by 4 <sup>2</sup>	2 by 4	2 by 6	2 by 6	2 by 6
	Diagonal.....	2 by 6	2 by 6	2 by 8	2 by 8	2 by 6
20	Upper frame.....	2 by 6 <sup>2</sup>	2 by 6	2 by 6	2 by 6	2 by 6
	Lower frame.....	2 by 4	2 by 4	2 by 4	2 by 4	2 by 4
	Strut.....	2 by 4	2 by 4	2 by 4	2 by 6	2 by 8
	Diagonal.....	2 by 6	2 by 6	2 by 8	2 by 6	2 by 8
24	Upper frame.....	2 by 8 <sup>3</sup>	2 by 6 <sup>2</sup>	2 by 6	2 by 6	2 by 6
	Lower frame.....	2 by 4 <sup>2</sup>	2 by 4	2 by 4	2 by 4	2 by 4
	Strut.....	2 by 4 <sup>2</sup>	2 by 4 <sup>2</sup>	2 by 4	2 by 6	2 by 8
	Diagonal.....	2 by 6	2 by 6	2 by 8	2 by 8	2 by 6
28	Upper frame.....	2 by 8 <sup>3</sup>	2 by 6 <sup>2</sup>	2 by 6 <sup>2</sup>	2 by 6	2 by 6
	Lower frame.....	2 by 4 <sup>2</sup>	2 by 4	2 by 4	2 by 4	2 by 4
	Strut.....	2 by 4	2 by 4	2 by 4 <sup>2</sup>	2 by 4	2 by 4
	Diagonal.....	2 by 6	2 by 6	2 by 8	2 by 8	2 by 8
32	Upper frame.....	2 by 10 <sup>4</sup>	2 by 8 <sup>2</sup>	2 by 6 <sup>3</sup>	2 by 6	2 by 6
	Lower frame.....	2 by 4 <sup>4</sup>	2 by 4	2 by 4	2 by 4	2 by 4
	Strut.....	2 by 4 <sup>4</sup>	2 by 4	2 by 4 <sup>2</sup>	2 by 4	2 by 4
	Diagonal.....	2 by 6 <sup>4</sup>	2 by 8	2 by 8	2 by 8	2 by 8

See footnotes at end of table.

TABLE 33.—Panel member sizes for crates <sup>1</sup> designed for a net load of 20,000 pounds—Continued  
10-FOOT-WIDE CRATE

Length	Member	Crate height					
		4 feet	6 feet	8 feet	10 feet	12 feet	
<i>Ft.</i>		<i>In.</i>	<i>In.</i>	<i>In.</i>	<i>In.</i>	<i>In.</i>	
	6	Upper frame.....	2 by 4	2 by 4	2 by 4	2 by 4	2 by 4
		Lower frame.....	2 by 4	2 by 4	2 by 4	2 by 4	2 by 4
		Strut.....	2 by 6	2 by 6	2 by 6	2 by 6	2 by 6
		Diagonal.....	2 by 6	2 by 6	2 by 6	2 by 8	2 by 6
	8	Upper frame.....	2 by 6	2 by 6	2 by 4	2 by 4	2 by 4
		Lower frame.....	2 by 4	2 by 4	2 by 4	2 by 4	2 by 4
		Strut.....	2 by 6	2 by 6	2 by 6	2 by 6	2 by 6
		Diagonal.....	2 by 6	2 by 8	2 by 8	2 by 6	2 by 8
	10	Upper frame.....	2 by 6	2 by 6	2 by 6	2 by 4	2 by 4
		Lower frame.....	2 by 4	2 by 4	4 by 4	2 by 4	2 by 4
		Strut.....	2 by 4	2 by 6	2 by 6	2 by 6	2 by 6
		Diagonal.....	2 by 6	2 by 6	2 by 8	2 by 6	2 by 6
	12	Upper frame.....	2 by 6	2 by 6	2 by 6	2 by 4	2 by 4
		Lower frame.....	2 by 4	2 by 4	2 by 4	2 by 4	2 by 4
		Strut.....	2 by 4	2 by 6	2 by 6	2 by 6	2 by 6
		Diagonal.....	2 by 6	2 by 6	2 by 6	2 by 8	2 by 6 <sup>2</sup>
	16	Upper frame.....	2 by 6	2 by 6	2 by 6	2 by 6	2 by 4
		Lower frame.....	2 by 4	2 by 4	2 by 4	2 by 4	2 by 4
		Strut.....	2 by 4 <sup>2</sup>	2 by 4	2 by 6	2 by 6	2 by 8
		Diagonal.....	2 by 6	2 by 6	2 by 8	2 by 8	2 by 6
	20	Upper frame.....	2 by 6 <sup>2</sup>	2 by 6	2 by 6	2 by 6	2 by 6
		Lower frame.....	2 by 4	2 by 4	2 by 4	2 by 4	2 by 4
		Strut.....	2 by 4	2 by 4	2 by 4	2 by 8	2 by 8
		Diagonal.....	2 by 6	2 by 6	2 by 8	2 by 8	2 by 8
	24	Upper frame.....	2 by 8 <sup>3</sup>	2 by 6 <sup>2</sup>	2 by 6	2 by 6	2 by 6
		Lower frame.....	2 by 4 <sup>2</sup>	2 by 4	2 by 4	2 by 4	2 by 4
		Strut.....	2 by 4 <sup>2</sup>	2 by 4 <sup>2</sup>	2 by 4	2 by 8	2 by 8
		Diagonal.....	2 by 6	2 by 6	2 by 8	2 by 8	2 by 8
	28	Upper frame.....	2 by 8 <sup>3</sup>	2 by 6 <sup>2</sup>	2 by 6 <sup>2</sup>	2 by 6	2 by 6
		Lower frame.....	2 by 4 <sup>2</sup>	2 by 4	2 by 4	2 by 4	2 by 4
		Strut.....	2 by 4	2 by 4	2 by 4 <sup>2</sup>	2 by 4	2 by 4
		Diagonal.....	2 by 6	2 by 6	2 by 8	2 by 8	2 by 8
	32	Upper frame.....	2 by 10 <sup>4</sup>	2 by 8 <sup>2</sup>	2 by 8 <sup>2</sup>	2 by 6	2 by 6
		Lower frame.....	2 by 4 <sup>4</sup>	2 by 4	2 by 4	2 by 4	2 by 4
		Strut.....	2 by 4 <sup>4</sup>	2 by 4	2 by 4 <sup>2</sup>	2 by 4	2 by 4
	Diagonal.....	2 by 6 <sup>4</sup>	2 by 8	2 by 8	2 by 8	2 by 8 <sup>2</sup>	

<sup>1</sup> Sizes are for uniform loads, but apply also to concentrated loads except as indicated.  
<sup>2</sup> For concentrated loads, increase the member size to the next larger size, as a 2 by 4 to a 2 by 6.  
<sup>3</sup> For concentrated loads, increase the member size to the second larger size, as a 2 by 6 to a 2 by 10.  
<sup>4</sup> Crates require special design for a concentrated load.

TABLE 34.—Panel member sizes for crates <sup>1</sup> designed for a net load of 25,000 pounds  
4-FOOT-WIDE CRATE

Length	Member	Crate height				
		4 feet	6 feet	8 feet	10 feet	12 feet
Ft.		<i>In.</i>	<i>In.</i>	<i>In.</i>	<i>In.</i>	<i>In.</i>
6	Upper frame.....	2 by 6	2 by 6	2 by 4	2 by 4	2 by 4
	Lower frame.....	2 by 4	2 by 4	2 by 4	2 by 4	2 by 4
	Strut.....	2 by 6	2 by 6	2 by 6	2 by 6	2 by 6
	Diagonal.....	2 by 6	2 by 8	2 by 8	2 by 8	2 by 8
8	Upper frame.....	2 by 6	2 by 6	2 by 4 <sup>2</sup>	2 by 4	2 by 4
	Lower frame.....	2 by 4	2 by 4	2 by 4	2 by 4	2 by 4
	Strut.....	2 by 6	2 by 6	2 by 6	2 by 6	2 by 6
	Diagonal.....	2 by 6	2 by 8	2 by 8	2 by 6	2 by 8
10	Upper frame.....	2 by 6	2 by 6	2 by 6	2 by 4	2 by 4
	Lower frame.....	2 by 4	2 by 4	2 by 4	2 by 4	2 by 4
	Strut.....	2 by 4	2 by 6	2 by 6	2 by 6 <sup>2</sup>	2 by 8
	Diagonal.....	2 by 6	2 by 6	2 by 8 <sup>2</sup>	2 by 8	2 by 6
12	Upper frame.....	2 by 6	2 by 6	2 by 6	2 by 4	2 by 4
	Lower frame.....	2 by 4	2 by 4	2 by 4	2 by 4	2 by 4
	Strut.....	2 by 4	2 by 6 <sup>2</sup>	2 by 6	2 by 8	2 by 8
	Diagonal.....	2 by 6	2 by 8	2 by 8	2 by 8	2 by 8
16	Upper frame.....	2 by 6	2 by 6	2 by 6	2 by 6	2 by 6
	Lower frame.....	2 by 4	2 by 4	2 by 4	2 by 4	2 by 4
	Strut.....	2 by 4 <sup>2</sup>	2 by 4	2 by 8	2 by 8	2 by 8
	Diagonal.....	2 by 6	2 by 6	2 by 8	2 by 8	2 by 8
20	Upper frame.....	2 by 8 <sup>2</sup>	2 by 6	2 by 6	2 by 6	2 by 6
	Lower frame.....	2 by 4	2 by 4	2 by 4	2 by 4	2 by 4
	Strut.....	2 by 4	2 by 4	2 by 4	2 by 8	2 by 8
	Diagonal.....	2 by 6	2 by 8	2 by 8	2 by 8	2 by 8
24	Upper frame.....	2 by 8 <sup>3</sup>	2 by 6 <sup>4</sup>	2 by 6	2 by 6	2 by 6
	Lower frame.....	2 by 4 <sup>3</sup>	2 by 4	2 by 4	2 by 4	2 by 4
	Strut.....	2 by 4 <sup>3</sup>	2 by 4 <sup>2</sup>	2 by 4	2 by 8	2 by 8
	Diagonal.....	2 by 6 <sup>3</sup>	2 by 8	2 by 8	2 by 8	2 by 8
28	Upper frame.....	2 by 10 <sup>3</sup>	2 by 8 <sup>2</sup>	2 by 6 <sup>2</sup>	2 by 6	2 by 6
	Lower frame.....	2 by 4 <sup>3</sup>	2 by 4	2 by 4	2 by 4	2 by 4
	Strut.....	2 by 4 <sup>3</sup>	2 by 4	2 by 4 <sup>2</sup>	2 by 4	2 by 4
	Diagonal.....	2 by 8 <sup>3</sup>	2 by 8	2 by 8	2 by 6 <sup>2</sup>	2 by 8
32	Upper frame.....	2 by 12 <sup>3</sup>	2 by 8 <sup>2</sup>	2 by 8 <sup>2</sup>	2 by 6	2 by 6
	Lower frame.....	2 by 6 <sup>3</sup>	2 by 4	2 by 4	2 by 4	2 by 4
	Strut.....	2 by 4 <sup>3</sup>	2 by 4	2 by 4 <sup>4</sup>	2 by 4	2 by 4
	Diagonal.....	2 by 8 <sup>3</sup>	2 by 8	2 by 8 <sup>2</sup>	2 by 8	2 by 8

See footnotes at end of table.

TABLE 34.—Panel member sizes for crates <sup>1</sup> designed for a net load of 25,000 pound—Continued  
6-FOOT-WIDE CRATE

Length	Member	Crate height				
		4 feet	6 feet	8 feet	10 feet	12 feet
<i>Ft.</i>		<i>In.</i>	<i>In.</i>	<i>In.</i>	<i>In.</i>	<i>In.</i>
6	Upper frame.....	2 by 6	2 by 6	2 by 4	2 by 4	2 by 4
	Lower frame.....	2 by 4	2 by 4	2 by 4	2 by 4	2 by 4
	Strut.....	2 by 6	2 by 6	2 by 6	2 by 6	2 by 8
	Diagonal.....	2 by 6	2 by 8	2 by 8	2 by 8	2 by 8
8	Upper frame.....	2 by 6	2 by 6	2 by 6	2 by 4 <sup>2</sup>	2 by 4
	Lower frame.....	2 by 4	2 by 4	2 by 4	2 by 4	2 by 4
	Strut.....	2 by 6	2 by 6	2 by 6	2 by 8	2 by 8
	Diagonal.....	2 by 6	2 by 8	2 by 8	2 by 6	2 by 8
10	Upper frame.....	2 by 6	2 by 6	2 by 6	2 by 4	2 by 4
	Lower frame.....	2 by 4	2 by 4	2 by 4	2 by 4	2 by 4
	Strut.....	2 by 4	2 by 6	2 by 8	2 by 8	2 by 8
	Diagonal.....	2 by 6	2 by 6	2 by 8 <sup>2</sup>	2 by 8	2 by 8
12	Upper frame.....	2 by 6	2 by 6	2 by 6	2 by 4	2 by 4
	Lower frame.....	2 by 4	2 by 4	2 by 4	2 by 4	2 by 4
	Strut.....	2 by 4	2 by 6 <sup>2</sup>	2 by 8	2 by 8	2 by 8
	Diagonal.....	2 by 6	2 by 8	2 by 8	2 by 8	2 by 8
16	Upper frame.....	2 by 6	2 by 6	2 by 6	2 by 6	2 by 6
	Lower frame.....	2 by 4	2 by 4	2 by 4	2 by 4	2 by 4
	Strut.....	2 by 4 <sup>2</sup>	2 by 4	2 by 8	2 by 8	2 by 8
	Diagonal.....	2 by 6	2 by 6	2 by 8	2 by 8	2 by 8
20	Upper frame.....	2 by 8 <sup>2</sup>	2 by 6	2 by 6	2 by 6	2 by 6
	Lower frame.....	2 by 4	2 by 4	2 by 4	2 by 4	2 by 4
	Strut.....	2 by 4	2 by 4	2 by 4	2 by 8	2 by 8
	Diagonal.....	2 by 8	2 by 8	2 by 8	2 by 8	2 by 8
24	Upper frame.....	2 by 10 <sup>3</sup>	2 by 8 <sup>4</sup>	2 by 8	2 by 8	2 by 6
	Lower frame.....	2 by 4 <sup>3</sup>	2 by 4	2 by 4	2 by 4	2 by 4
	Strut.....	2 by 4 <sup>3</sup>	2 by 4 <sup>2</sup>	2 by 4	2 by 8	2 by 8
	Diagonal.....	2 by 8 <sup>3</sup>	2 by 8	2 by 10	2 by 8	2 by 8
28	Upper frame.....	2 by 10 <sup>3</sup>	2 by 8 <sup>2</sup>	2 by 8 <sup>2</sup>	2 by 6	2 by 6
	Lower frame.....	2 by 4 <sup>3</sup>	2 by 4	2 by 4	2 by 4	2 by 4
	Strut.....	2 by 4 <sup>3</sup>	2 by 4	2 by 4 <sup>4</sup>	2 by 4	2 by 4
	Diagonal.....	2 by 8 <sup>3</sup>	2 by 8	2 by 8	2 by 6 <sup>2</sup>	2 by 8
32	Upper frame.....	2 by 12 <sup>3</sup>	2 by 8 <sup>2</sup>	2 by 8 <sup>2</sup>	2 by 8	2 by 6
	Lower frame.....	2 by 6 <sup>3</sup>	2 by 4	2 by 4	2 by 4	2 by 4
	Strut.....	2 by 4 <sup>3</sup>	2 by 4	2 by 4 <sup>4</sup>	2 by 4	2 by 4
	Diagonal.....	2 by 8 <sup>3</sup>	2 by 8	2 by 10	2 by 8	2 by 8 <sup>2</sup>

See footnotes at end of table.

TABLE 34.—Panel member sizes for crates <sup>1</sup> designed for a net load of 25,000 pounds—Continued  
8-FOOT-WIDE CRATE

Length	Member	Crate height				
		4 feet	6 feet	8 feet	10 feet	12 feet
Ft.		<i>In.</i>	<i>In.</i>	<i>In.</i>	<i>In.</i>	<i>In.</i>
6	Upper frame.....	2 by 6	2 by 6	2 by 4	2 by 4	2 by 4
	Lower frame.....	2 by 4	2 by 4	2 by 4	2 by 4	2 by 4
	Strut.....	2 by 6	2 by 6	2 by 8	2 by 8	2 by 8
8	Diagonal.....	2 by 6	2 by 8	2 by 8	2 by 8	2 by 8
	Upper frame.....	2 by 6	2 by 6	2 by 4 <sup>2</sup>	2 by 4	2 by 4
	Lower frame.....	2 by 4	2 by 4	2 by 4	2 by 4	2 by 4
10	Strut.....	2 by 6	2 by 6 <sup>2</sup>	2 by 8	2 by 8	2 by 8
	Diagonal.....	2 by 6	2 by 8	2 by 8	2 by 6	2 by 8
	Upper frame.....	2 by 6	2 by 6	2 by 6	2 by 6	2 by 4
12	Lower frame.....	2 by 4	2 by 4	2 by 4	2 by 4	2 by 4
	Strut.....	2 by 4	2 by 8	2 by 8	2 by 8	2 by 8
	Diagonal.....	2 by 6 <sup>2</sup>	2 by 8	2 by 8	2 by 8	2 by 8
16	Upper frame.....	2 by 8	2 by 6	2 by 6	2 by 6	2 by 6
	Lower frame.....	2 by 4	2 by 4	2 by 4	2 by 4	2 by 4
	Strut.....	2 by 4 <sup>2</sup>	2 by 4	2 by 8	2 by 8	2 by 8
20	Diagonal.....	2 by 8	2 by 8	2 by 8	2 by 8	2 by 8
	Upper frame.....	2 by 8 <sup>2</sup>	2 by 6	2 by 6	2 by 6	2 by 6
	Lower frame.....	2 by 4	2 by 4	2 by 4	2 by 4	2 by 4
24	Strut.....	2 by 4	2 by 4	2 by 4	2 by 8	2 by 8
	Diagonal.....	2 by 8	2 by 8	2 by 8	2 by 8	2 by 8
	Upper frame.....	2 by 10 <sup>3</sup>	2 by 8 <sup>2</sup>	2 by 8	2 by 8	2 by 6
28	Lower frame.....	2 by 4 <sup>3</sup>	2 by 4	2 by 4	2 by 4	2 by 4
	Strut.....	2 by 4 <sup>3</sup>	2 by 4 <sup>4</sup>	2 by 4	2 by 8	2 by 8
	Diagonal.....	2 by 8 <sup>3</sup>	2 by 8	2 by 10	2 by 10	2 by 8
32	Upper frame.....	2 by 10 <sup>3</sup>	2 by 8 <sup>2</sup>	2 by 8 <sup>2</sup>	2 by 8	2 by 6
	Lower frame.....	2 by 4 <sup>3</sup>	2 by 4	2 by 4	2 by 4	2 by 4
	Strut.....	2 by 4 <sup>3</sup>	2 by 4	2 by 4 <sup>4</sup>	2 by 4	2 by 6
	Diagonal.....	2 by 8 <sup>3</sup>	2 by 8	2 by 10	2 by 6 <sup>2</sup>	2 by 8
	Upper frame.....	2 by 12 <sup>3</sup>	2 by 8 <sup>2</sup>	2 by 8 <sup>2</sup>	2 by 8	2 by 6
	Lower frame.....	2 by 6 <sup>3</sup>	2 by 4	2 by 4	2 by 4	2 by 4
	Strut.....	2 by 4 <sup>3</sup>	2 by 4	2 by 4 <sup>4</sup>	2 by 4	2 by 6
	Diagonal.....	2 by 8 <sup>3</sup>	2 by 8	2 by 10	2 by 10	2 by 10

See footnotes at end of table.

TABLE 34.—Panel member sizes for crates <sup>1</sup> designed for a net load of 25,000 pounds—Continued

10-FOOT-WIDE CRATE

Length	Member	Crate height					
		4 feet	6 feet	8 feet	10 feet	12 feet	
Ft.		<i>In.</i>	<i>In.</i>	<i>In.</i>	<i>In.</i>	<i>In.</i>	
	6	Upper frame.....	2 by 6	2 by 6	2 by 4	2 by 4	2 by 4
		Lower frame.....	2 by 4	2 by 4	2 by 4	2 by 4	2 by 4
		Strut.....	2 by 6	2 by 6	2 by 8	2 by 8	2 by 8
	8	Diagonal.....	2 by 6	2 by 8	2 by 8	2 by 8	2 by 8
		Upper frame.....	2 by 6	2 by 6	2 by 4 <sup>2</sup>	2 by 4	2 by 4
		Lower frame.....	2 by 4	2 by 4	2 by 4	2 by 4	2 by 4
	10	Strut.....	2 by 6	2 by 8	2 by 8	2 by 8	2 by 8
		Diagonal.....	2 by 6	2 by 8	2 by 8	2 by 6	2 by 10
		Upper frame.....	2 by 6	2 by 6	2 by 6	2 by 4	2 by 4
	12	Lower frame.....	2 by 4	2 by 4	2 by 4	2 by 4	2 by 4
		Strut.....	2 by 4	2 by 8	2 by 8	2 by 8	2 by 8
Diagonal.....		2 by 4	2 by 8	2 by 8	2 by 8	2 by 8	
16	Upper frame.....	2 by 8	2 by 8	2 by 8	2 by 8	2 by 8	
	Lower frame.....	2 by 6	2 by 8	2 by 6	2 by 6	2 by 6	
	Strut.....	2 by 4	2 by 4	2 by 4	2 by 4	2 by 4	
20	Diagonal.....	2 by 4 <sup>2</sup>	2 by 4	2 by 8	2 by 8	2 by 8	
	Upper frame.....	2 by 8	2 by 8	2 by 10	2 by 8	2 by 8	
	Lower frame.....	2 by 6	2 by 6	2 by 6	2 by 6	2 by 6	
24	Strut.....	2 by 4	2 by 4	2 by 4	2 by 4	2 by 4	
	Diagonal.....	2 by 4	2 by 4	2 by 4	2 by 8	2 by 8	
	Upper frame.....	2 by 8 <sup>2</sup>	2 by 8	2 by 8	2 by 8	2 by 8	
28	Lower frame.....	2 by 10 <sup>2</sup>	2 by 8 <sup>2</sup>	2 by 8	2 by 8	2 by 6	
	Strut.....	2 by 4 <sup>2</sup>	2 by 4	2 by 4	2 by 4	2 by 4	
	Diagonal.....	2 by 4 <sup>2</sup>	2 by 4	2 by 4 <sup>4</sup>	2 by 6	2 by 6	
32	Upper frame.....	2 by 8 <sup>2</sup>	2 by 8	2 by 10	2 by 8 <sup>2</sup>	2 by 10	
	Lower frame.....	2 by 12 <sup>2</sup>	2 by 10	2 by 8 <sup>2</sup>	2 by 8	2 by 6	
	Strut.....	2 by 6 <sup>2</sup>	2 by 4	2 by 4	2 by 4	2 by 4	
	Diagonal.....	2 by 4 <sup>2</sup>	2 by 4	2 by 4 <sup>4</sup>	2 by 6	2 by 6	
		2 by 8 <sup>2</sup>	2 by 8	2 by 10	2 by 10	2 by 10	

<sup>1</sup> Sizes are for uniform loads but apply also to concentrated loads except as indicated.

<sup>2</sup> For concentrated loads, increase the member size to the next larger size, as a 2 by 4 to a 2 by 6.

<sup>3</sup> Crates require special design for a concentrated load.

<sup>4</sup> For concentrated loads, increase the member size to the second larger size, as a 2 by 6 to a 2 by 10.

TABLE 35.—Panel member sizes for crates <sup>1</sup> designed for a net load of 30,000 pounds

4-FOOT-WIDE CRATE

Length	Member	Crate height						
		4 feet	6 feet	8 feet	10 feet	12 feet		
<i>Ft.</i>		<i>In.</i>	<i>In.</i>	<i>In.</i>	<i>In.</i>	<i>In.</i>		
	6	Upper frame.....	2 by 6	2 by 6	2 by 4	2 by 4	2 by 4	
		Lower frame.....	2 by 4	2 by 4	2 by 4	2 by 4	2 by 4	
		Strut.....	2 by 8	2 by 8	2 by 8	2 by 8	2 by 8	
		Diagonal.....	2 by 8	2 by 8	2 by 8	2 by 8	2 by 8	
		8	Upper frame.....	2 by 6	2 by 6	2 by 6	2 by 4	2 by 4
		Lower frame.....	2 by 4	2 by 4	2 by 4	2 by 4	2 by 4	
		Strut.....	2 by 8	2 by 8	2 by 10	2 by 8	2 by 8	
		Diagonal.....	2 by 8	2 by 10	2 by 10	2 by 8	2 by 10	
		10	Upper frame.....	2 by 6	2 by 6	2 by 6	2 by 4	2 by 4
		Lower frame.....	2 by 4	2 by 4	2 by 4	2 by 4	2 by 4	
		Strut.....	2 by 4	2 by 8	2 by 10	2 by 8	2 by 8	
		Diagonal.....	2 by 8	2 by 8	2 by 10	2 by 8	2 by 8	
		12	Upper frame.....	2 by 6	2 by 6	2 by 6	2 by 4	2 by 4
		Lower frame.....	2 by 4	2 by 4	2 by 4	2 by 4	2 by 4	
		Strut.....	2 by 4	2 by 8	2 by 8	2 by 8	2 by 8	
		Diagonal.....	2 by 8	2 by 8	2 by 8	2 by 10	2 by 10	
		16	Upper frame.....	2 by 8	2 by 6	2 by 6	2 by 6	2 by 6
		Lower frame.....	2 by 4	2 by 4	2 by 4	2 by 4	2 by 4	
		Strut.....	2 by 4 <sup>2</sup>	2 by 4	2 by 10	2 by 8	2 by 8	
	Diagonal.....	2 by 8	2 by 8	2 by 10	2 by 8	2 by 8		
	20	Upper frame.....	2 by 8 <sup>2</sup>	2 by 8	2 by 6	2 by 6	2 by 6	
	Lower frame.....	2 by 4	2 by 4	2 by 4	2 by 4	2 by 4		
	Strut.....	2 by 4	2 by 4	2 by 4	2 by 8	2 by 8		
	Diagonal.....	2 by 8	2 by 8	2 by 10	2 by 8	2 by 8 <sup>3</sup>		
	24	Upper frame.....	2 by 10 <sup>4</sup>	2 by 8 <sup>3</sup>	2 by 8	2 by 8	2 by 6	
	Lower frame.....	2 by 4 <sup>4</sup>	2 by 4	2 by 4	2 by 4	2 by 4		
	Strut.....	2 by 4 <sup>4</sup>	2 by 4 <sup>2</sup>	2 by 4 <sup>3</sup>	2 by 8	2 by 8		
	Diagonal.....	2 by 8 <sup>4</sup>	2 by 8	2 by 10	2 by 10	2 by 10		
	28	Upper frame.....	2 by 12 <sup>4</sup>	2 by 8 <sup>3</sup>	2 by 8 <sup>3</sup>	2 by 8	2 by 6	
	Lower frame.....	2 by 6 <sup>4</sup>	2 by 4	2 by 4	2 by 4	2 by 4		
	Strut.....	2 by 4 <sup>4</sup>	2 by 4	2 by 4 <sup>2</sup>	2 by 4	2 by 6		
	Diagonal.....	2 by 8 <sup>4</sup>	2 by 8	2 by 10	2 by 10	2 by 10		
	32	Upper frame.....	2 by 12 <sup>4</sup>	2 by 10 <sup>3</sup>	2 by 8 <sup>3</sup>	2 by 6 <sup>3</sup>	2 by 6	
	Lower frame.....	2 by 6 <sup>4</sup>	2 by 4 <sup>3</sup>	2 by 4 <sup>3</sup>	2 by 4	2 by 4		
	Strut.....	2 by 4 <sup>4</sup>	2 by 4	2 by 4 <sup>2</sup>	2 by 6	2 by 6		
	Diagonal.....	2 by 8 <sup>4</sup>	2 by 10	2 by 10	2 by 10	2 by 10		

See footnotes at end of table.

TABLE 35.—Panel member sizes for crates <sup>1</sup> designed for a net load of 30,000 pounds—Continued

6-FOOT-WIDE CRATE

Length	Member	Crate height				
		4 feet	6 feet	8 feet	10 feet	12 feet
6	Upper frame.....	<i>In.</i> 2 by 6	<i>In.</i> 2 by 6	<i>In.</i> 2 by 4 <sup>3</sup>	<i>In.</i> 2 by 4	<i>In.</i> 2 by 4
	Lower frame.....	2 by 4	2 by 4	2 by 4	2 by 4	2 by 4
	Strut.....	2 by 8	2 by 8	2 by 8	2 by 8	2 by 8
8	Upper frame.....	2 by 6	2 by 6	2 by 6	2 by 4	2 by 4
	Lower frame.....	2 by 4	2 by 4	2 by 4	2 by 4	2 by 4
	Strut.....	2 by 8	2 by 8	2 by 10	2 by 8	2 by 8
10	Upper frame.....	2 by 6	2 by 6	2 by 6	2 by 4	2 by 4
	Lower frame.....	2 by 4	2 by 4	2 by 4	2 by 4	2 by 4
	Strut.....	2 by 4	2 by 8	2 by 10	2 by 8	2 by 8
12	Upper frame.....	2 by 6	2 by 6	2 by 6	2 by 4	2 by 4
	Lower frame.....	2 by 4	2 by 4	2 by 4	2 by 4	2 by 4
	Strut.....	2 by 4	2 by 8	2 by 8	2 by 8	2 by 8
16	Upper frame.....	2 by 8	2 by 6	2 by 6	2 by 6	2 by 6
	Lower frame.....	2 by 4	2 by 4	2 by 4	2 by 4	2 by 4
	Strut.....	2 by 4 <sup>2</sup>	2 by 4	2 by 10	2 by 8	2 by 8
20	Upper frame.....	2 by 8	2 by 8	2 by 10	2 by 10	2 by 8
	Lower frame.....	2 by 4	2 by 4	2 by 4	2 by 4	2 by 4
	Strut.....	2 by 4	2 by 4	2 by 4	2 by 8	2 by 8
24	Upper frame.....	2 by 8 <sup>2</sup>	2 by 8	2 by 6	2 by 6	2 by 6
	Lower frame.....	2 by 4	2 by 4	2 by 4	2 by 4	2 by 4
	Strut.....	2 by 4	2 by 4	2 by 4	2 by 8	2 by 8
28	Upper frame.....	2 by 8	2 by 10	2 by 10	2 by 8	2 by 10
	Lower frame.....	2 by 10 <sup>4</sup>	2 by 8 <sup>2</sup>	2 by 8	2 by 8	2 by 6
	Strut.....	2 by 4 <sup>4</sup>	2 by 4 <sup>3</sup>	2 by 4	2 by 4	2 by 4
32	Upper frame.....	2 by 4 <sup>4</sup>	2 by 4 <sup>2</sup>	2 by 4 <sup>3</sup>	2 by 8	2 by 10
	Lower frame.....	2 by 8 <sup>4</sup>	2 by 8	2 by 10	2 by 10	2 by 10
	Strut.....	2 by 12 <sup>4</sup>	2 by 10 <sup>3</sup>	2 by 8 <sup>3</sup>	2 by 8	2 by 6
36	Upper frame.....	2 by 6 <sup>4</sup>	2 by 4 <sup>3</sup>	2 by 4	2 by 4	2 by 4
	Lower frame.....	2 by 4 <sup>4</sup>	2 by 4	2 by 6 <sup>3</sup>	2 by 6	2 by 6
	Strut.....	2 by 8 <sup>4</sup>	2 by 8	2 by 10	2 by 10	2 by 10
40	Upper frame.....	2 by 12 <sup>4</sup>	2 by 10 <sup>3</sup>	2 by 8 <sup>3</sup>	2 by 8	2 by 8
	Lower frame.....	2 by 8 <sup>4</sup>	2 by 4 <sup>3</sup>	2 by 4 <sup>3</sup>	2 by 4	2 by 4
	Strut.....	2 by 4 <sup>4</sup>	2 by 4	2 by 6 <sup>3</sup>	2 by 6	2 by 6
44	Upper frame.....	2 by 4 <sup>4</sup>	2 by 10	2 by 10	2 by 10	2 by 10
	Lower frame.....	2 by 8 <sup>4</sup>	2 by 10	2 by 10	2 by 10	2 by 10
	Strut.....	2 by 8 <sup>4</sup>	2 by 10	2 by 10	2 by 10	2 by 10

See footnotes at end of table.

TABLE 35.—Panel member sizes for crates <sup>1</sup> designed for a net load of 30,000 pounds—Continued  
8-FOOT-WIDE CRATE

Length	Member	Crate height				
		4 feet	6 feet	8 feet	10 feet	12 feet
<i>Ft.</i>		<i>In.</i>	<i>In.</i>	<i>In.</i>	<i>In.</i>	<i>In.</i>
6	Upper frame.....	2 by 6	2 by 6	2 by 6	2 by 6	2 by 6
	Lower frame.....	2 by 4	2 by 4	2 by 4	2 by 4	2 by 4
	Strut.....	2 by 8	2 by 8	2 by 8	2 by 8	2 by 8
	Diagonal.....	2 by 8	2 by 8	2 by 8	2 by 10	2 by 8
8	Upper frame.....	2 by 6	2 by 6	2 by 6	2 by 4	2 by 4
	Lower frame.....	2 by 4	2 by 4	2 by 4	2 by 4	2 by 4
	Strut.....	2 by 8	2 by 8	2 by 10	2 by 8	2 by 8
	Diagonal.....	2 by 8	2 by 10	2 by 10	2 by 8	2 by 10
10	Upper frame.....	2 by 6	2 by 6	2 by 6	2 by 4	2 by 4
	Lower frame.....	2 by 4	2 by 4	2 by 4	2 by 4	2 by 4
	Strut.....	2 by 4	2 by 8	2 by 10	2 by 8	2 by 8
	Diagonal.....	2 by 8	2 by 8	2 by 10	2 by 8	2 by 8
12	Upper frame.....	2 by 6	2 by 6	2 by 6	2 by 4	2 by 4
	Lower frame.....	2 by 4	2 by 4	2 by 4	2 by 4	2 by 4
	Strut.....	2 by 4	2 by 8	2 by 8	2 by 8	2 by 8
	Diagonal.....	2 by 8	2 by 8	2 by 10	2 by 10	2 by 10
16	Upper frame.....	2 by 8	2 by 6	2 by 6	2 by 6	2 by 6
	Lower frame.....	2 by 4	2 by 4	2 by 4	2 by 4	2 by 4
	Strut.....	2 by 4 <sup>2</sup>	2 by 4	2 by 10	2 by 8	2 by 8
	Diagonal.....	2 by 8	2 by 8	2 by 10	2 by 10	2 by 8 <sup>3</sup>
20	Upper frame.....	2 by 8 <sup>2</sup>	2 by 8	2 by 6	2 by 6	2 by 6
	Lower frame.....	2 by 4 <sup>3</sup>	2 by 4	2 by 4	2 by 4	2 by 4
	Strut.....	2 by 4	2 by 4	2 by 6	2 by 8	2 by 10
	Diagonal.....	2 by 8	2 by 10	2 by 10	2 by 10	2 by 10
24	Upper frame.....	2 by 10 <sup>4</sup>	2 by 8 <sup>2</sup>	2 by 8	2 by 8	2 by 8
	Lower frame.....	2 by 4 <sup>4</sup>	2 by 4 <sup>3</sup>	2 by 4	2 by 4	2 by 4
	Strut.....	2 by 4 <sup>4</sup>	2 by 6 <sup>3</sup>	2 by 6	2 by 10	2 by 10
	Diagonal.....	2 by 8 <sup>4</sup>	2 by 10	2 by 10	2 by 10	2 by 10
28	Upper frame.....	2 by 12 <sup>4</sup>	2 by 10 <sup>3</sup>	2 by 8 <sup>3</sup>	2 by 8	2 by 8
	Lower frame.....	2 by 6 <sup>4</sup>	2 by 4 <sup>3</sup>	2 by 4	2 by 4	2 by 4
	Strut.....	2 by 4 <sup>4</sup>	2 by 6	2 by 6 <sup>3</sup>	2 by 6	2 by 6
	Diagonal.....	2 by 8 <sup>4</sup>	2 by 10	2 by 10	2 by 10	2 by 10
32	Upper frame.....	2 by 12 <sup>4</sup>	2 by 10 <sup>3</sup>	2 by 10	2 by 8	2 by 8
	Lower frame.....	2 by 8 <sup>4</sup>	2 by 4 <sup>3</sup>	2 by 4 <sup>3</sup>	2 by 4	2 by 4
	Strut.....	2 by 4 <sup>4</sup>	2 by 6	2 by 6 <sup>3</sup>	2 by 6	2 by 6
	Diagonal.....	2 by 8 <sup>4</sup>	2 by 10	2 by 10	2 by 10	2 by 10

See footnotes at end of table.

TABLE 35.—Panel member sizes for crates <sup>1</sup> designed for a net load of 30,000 pounds—Continued  
10-FOOT-WIDE CRATE

Length	Member	Crate height				
		4 feet	6 feet	8 feet	10 feet	12 feet
Ft.		<i>In.</i>	<i>In.</i>	<i>In.</i>	<i>In.</i>	<i>In.</i>
6	Upper frame.....	2 by 6	2 by 6	2 by 6	2 by 4	2 by 4
	Lower frame.....	2 by 4	2 by 4	2 by 4	2 by 4	2 by 4
	Strut.....	2 by 8	2 by 8	2 by 8	2 by 8	2 by 8
	Diagonal.....	2 by 8	2 by 8	2 by 8	2 by 10	2 by 10
8	Upper frame.....	2 by 6	2 by 6	2 by 6	2 by 4	2 by 4
	Lower frame.....	2 by 4	2 by 4	2 by 4	2 by 4	2 by 4
	Strut.....	2 by 8	2 by 8	2 by 10	2 by 8	2 by 8
	Diagonal.....	2 by 8	2 by 10	2 by 10	2 by 8	2 by 10
10	Upper frame.....	2 by 6	2 by 6	2 by 6	2 by 4	2 by 4
	Lower frame.....	2 by 4	2 by 4	2 by 4	2 by 4	2 by 4
	Strut.....	2 by 4	2 by 8	2 by 10	2 by 8	2 by 8
	Diagonal.....	2 by 8	2 by 8	2 by 10	2 by 8	2 by 8
12	Upper frame.....	2 by 6	2 by 6	2 by 6	2 by 4	2 by 4
	Lower frame.....	2 by 4	2 by 4	2 by 4	2 by 4	2 by 4
	Strut.....	2 by 4	2 by 8	2 by 8	2 by 8	2 by 8
	Diagonal.....	2 by 8	2 by 8	2 by 10	2 by 10	2 by 10
16	Upper frame.....	2 by 8	2 by 6	2 by 6	2 by 6	2 by 6
	Lower frame.....	2 by 4	2 by 4	2 by 4	2 by 4	2 by 4
	Strut.....	2 by 4 <sup>2</sup>	2 by 4	2 by 10	2 by 10	2 by 10
	Diagonal.....	2 by 8	2 by 8	2 by 10	2 by 10	2 by 10
20	Upper frame.....	2 by 10 <sup>3</sup>	2 by 10	2 by 6	2 by 6	2 by 6
	Lower frame.....	2 by 4 <sup>3</sup>	2 by 4	2 by 4	2 by 4	2 by 4
	Strut.....	2 by 4	2 by 4	2 by 6	2 by 10	2 by 10
	Diagonal.....	2 by 8	2 by 10 <sup>3</sup>	2 by 10	2 by 10	2 by 10
24	Upper frame.....	2 by 10 <sup>4</sup>	2 by 8 <sup>2</sup>	2 by 8	2 by 8	2 by 8
	Lower frame.....	2 by 4 <sup>4</sup>	2 by 4 <sup>3</sup>	2 by 4	2 by 4	2 by 4
	Strut.....	2 by 4 <sup>4</sup>	2 by 6 <sup>3</sup>	2 by 6	2 by 10	2 by 10
	Diagonal.....	2 by 8 <sup>4</sup>	2 by 10	2 by 10	2 by 10	2 by 10
28	Upper frame.....	2 by 12 <sup>4</sup>	2 by 10 <sup>3</sup>	2 by 8 <sup>3</sup>	2 by 8	2 by 8
	Lower frame.....	2 by 6 <sup>4</sup>	2 by 4 <sup>3</sup>	2 by 4	2 by 4	2 by 4
	Strut.....	2 by 4 <sup>4</sup>	2 by 6	2 by 6 <sup>3</sup>	2 by 6	2 by 6
	Diagonal.....	2 by 8 <sup>4</sup>	2 by 10	2 by 10	2 by 10	2 by 10
32	Upper frame.....	2 by 12 <sup>4</sup>	2 by 10 <sup>3</sup>	2 by 10	2 by 8	2 by 8
	Lower frame.....	2 by 8 <sup>4</sup>	2 by 4 <sup>3</sup>	2 by 4 <sup>3</sup>	2 by 4	2 by 4
	Strut.....	2 by 4 <sup>4</sup>	2 by 6	2 by 6 <sup>3</sup>	2 by 6	2 by 6
	Diagonal.....	2 by 8 <sup>4</sup>	2 by 10	2 by 12	2 by 10	2 by 12

<sup>1</sup> Sizes are for uniform loads but apply to concentrated loads except as indicated.

<sup>2</sup> For concentrated loads, increase the member size to the second larger size, as a 2 by 6 to a 2 by 10.

<sup>3</sup> For concentrated loads, increase the member size to the next larger size, as a 2 by 4 to a 2 by 6.

<sup>4</sup> Crates require special design for a concentrated load.

## APPENDIX II. DETAILS OF SHIPPING

### MARKING

All crates must have some markings on them to show their destination, to whom they are consigned, and the name of the consignor. Many crates also have markings that describe the contents, for advertising or storage information. In some government shipments, however, especially in time of war, a code is used to minimize pilfering. The code marking is more important on export shipments, particularly for containers that will be subjected to numerous handlings.

The Interstate Commerce Commission requires special marking of delicate or dangerous articles, for the protection of both the article and those handling the container. Label requirements vary a great deal between items. For this reason, all special markings and shipping instructions should conform to the latest ICC Regulations. These regulations cover the land and water transportation of explosives and other dangerous articles and include specifications for the required shipping containers.

Other markings used on the exteriors of many crates, especially those destined for foreign areas, concern handling and opening. A container that may be reused is often marked "Reusable Container" and, if opening directions are required, "To Open-Remove End" or a similar phrase might be employed. Inspection doors or inspection ports should have suitable markings.

Packed crates over 10 feet long and crates with their balance point off center should be marked to indicate the balance point. This is usually accomplished by stenciling or painting a stripe on each side of the crate, generally extending about 18 inches from the lower edge of each side. The words "Center of Balance" should appear next to the stripes. A convenient method of locating these stripes is by moving the loaded crate over a roller to find the center of balance.

When grabhook handling is anticipated, an area is marked over the center of balance on each side near the top of the crate at the reinforcing joists. The words "Grabhook Here" should be painted or stenciled near this marked area. Crates with provisions for slings under the ends of the skids should have a stripe located at each lower corner of the sides with the words "Sling Here."

It is often helpful to include markings to reduce the chance that the crate will be placed on its side. Ordinarily the presence of the skids is enough to indicate the correct position during storage or shipping. However, high, narrow crates may be placed on their sides; if heavy boxes

or crates are placed on them, their contents may be damaged. The use of a well-defined arrow and the word "Up" marked on each side of the crate near the top is a precaution that may pay dividends in placing and handling odd-size crates.

For the convenience of the personnel concerned with the transportation of the crate, its dimensions, weight, and volume might well be marked on the exterior. A bill of lading is needed on many crates to assist in unpacking, especially where a number of items are included in one crate. This minimizes the chance of missing small items.

While ordinary ink or even crayon may be used for marking crates on some local shipments, more permanent materials should be used for normal shipping conditions. Waterproof ink or paint should be used for marking crates to be shipped overseas or that might be exposed to weathering or placed in storage.

The International Union of Marine Insurance has found that proper marking is very important in the safe arrival of export and other shipments. It has recommended the following fundamental marking rules:

1. Unless local regulations prohibit, use blind marks where goods are susceptible to pilferage. Change the marks periodically to prevent handlers from becoming familiar with them. Trade names and consignee's or shipper's names should not indicate the nature of the contents.

2. Consignee identification marks and port marks that show destination and transfer points should be large, clear, and applied only by stencil with waterproof ink. They should be applied on two faces of the container, preferably sides or ends.

3. The proper cautionary marks in English and in the language of destination should be used when necessary. These include such cautions as "Handle With Care," "Glass," and "Use No Hooks." While the marks do not always insure proper handling, they will often pay for the little trouble required to apply them.

### PACKING LISTS

The packing list may be similar to a bill of lading but have more descriptive detail on the contents. It should be made at least in triplicate; one copy is retained by the shipper, another goes with the invoice, and a third is packed with the item, in a location where it cannot be lost or damaged and is protected from the weather. The interior of the crate near or on a removable end or top is often used for this purpose. The

recipient can then check the contents and note any missing items.

## SHIPPING LOSS PREVENTION

Port and transportation facilities have improved in many countries since World War II, but losses still occur from theft, pilferage, nondelivery, breakage, and so forth. Losses can be minimized by using proper containers and good packing and anchoring.

For example, the findings of an insurance company<sup>6</sup> reveal that 80 percent of all losses on overseas shipments for the 5 years 1955 to 1959 were preventable, as shown in the following tabulation:

<i>Cause of loss</i>	<i>All losses 1955-59 (percent)</i>
Major casualties, largely nonpreventable (sinkings, strandings, fires, collisions)-----	20
Preventable losses:	
Sea water and heavy weather-----	5
Theft, pilferage, and nondelivery-----	21
Handling and stowage-----	41
Water damage-----	13

The vital importance of preventing these losses has been emphasized by the recommendations of the International Union of Marine Insurance. These recommendations concern, for the most part, the proper construction of cartons, nailed wood boxes, crates, and other containers. They are aimed at correcting three principal difficulties: (1) Improper or inadequate securing of the item to the crate base, (2) weak or insufficiently supported top construction, and (3) inadequate frame members or skids. The use of grabhooks on unsupported panels, lack of diagonal bracing, and lack of handling markings were other causes for damage.

The construction outlined for the sheathed and unsheathed crates in this publication is more than adequate to withstand the handling hazards that ordinarily cause damage.

## EXPORT SHIPPING

Export shipping rates are usually based upon a ton (generally 2,240 pounds, but sometimes only 2,000 pounds) or on 40 cubic feet, whichever produces the greater tariff. Generally speaking the volume rate applies, unless the crate or box weighs  $\frac{2,240}{40}$  or 56 pounds per cubic foot. Since

most material shipped has a much lower density than this, it is important to decrease the cubic displacement of a crate. A loaded crate that weighs 27 pounds per cubic foot will cost twice as much per pound to ship as a crate of the same volume that weighs 54 pounds per cubic foot.

<sup>6</sup> Insurance Company of North America. Ports of the World. Ed. 6. Philadelphia 1, Pa.

## ANCHORING CRATES TO SHIP SURFACES

Large crates assigned to foreign ports are often stored on the deck of the ship during transport. When it is known that crates will be shipped on decks of ships and must be anchored to them, preparations during construction usually consist of drilling holes into the outside skids to receive eyebolts. The holes should be centered between the top and bottom of the skids, 8 to 12 inches from the ends. The base of the crate should be fitted with not less than four eyebolts. The crate should be anchored with rods, but when their use is impractical, wire rope of equivalent strength may be used. These tie rods or wire ropes are fastened to pad eyes welded to the deck. Tie rods should be provided with turnbuckles, and the ends of the wire ropes secured with at least three cable clamps. If the crate is high or top loaded, supplementary lashing over the top may be used as necessary to relieve racking strains and as an aid to anchoring.

## CARLOADING CRATES

The countless pages of print devoted during the last half century to the loading and stowing of freight in rail shipments testify to the economic importance of the carloading phase of materials handling. Damage-free delivery is obviously of paramount importance. Consequently, carloading, blocking, and bracing are critical steps in the handling of crated items. If they are insecure or inadequate and the item is damaged, the skill and labor expended to produce and package it are wasted.

### Freight Classification

Committees classify commodities shipped by rail so that ratings will be uniform. The freight rates that apply to the classifications are established by the individual railroads through their rating committees. The container in which an item is shipped and the packing protection given an article are factors used to determine classification ratings. The rules provide specific packing for a large number of commodities and give more or less definite packing specifications for those not listed. The carriers may refuse to accept any article tendered them for transportation if it is not packed according to their rules. If they accept, they may charge a penalty.

### Car Impacts

Proper application of the basic principles of good carloading will protect crates against the normal impacts to which shipments are subjected during the handling of cars. Impacts that usually occur during switching operations can be quite severe. Such impacts depend on the

coupling speed and vary as the square of that speed. For example, the impact due to a speed of 4 miles per hour is 16 times as great as the impact due to a speed of 1 mile per hour. Similarly, at a speed of 8 miles per hour the impact is 64 times as great as at 1 mile per hour.

### Loading

Crates are carried in closed cars or in open cars or flatcars. The selection of the proper freight car depends on the object being shipped, the type of crate, and the availability of cars. The water-proofness of boxcars may be very important with many items of lading. Good flooring and side sheathing are necessary when heavy blocking and bracing must be fastened to them. Blocking and bracing must be carefully done on flatcars because, if fastenings give way, the crate may be lost. Blocking and bracing will vary with the container being shipped, especially in open cars, and may consist of wood, wire, strapping, or combinations of them. In any type of car the crate should be properly placed or the item may be injured even though it is properly packed. Not only must the endwise movement of the car be considered, but also the sideway of the moving train and the up-and-down movement of the car. Sideway and up-and-down movements occur while the train is traveling, endwise movements mainly during starting or stopping. The distribution of loads over the car must comply with the rules of the transportation company.

### Types of Loads

Freight car loads are of two general types, floating and rigid. The floating load moves upon impact. Since a slight movement is enough to reduce the shock of impact, methods used for floating loads may allow a slight movement under high impacts. Rigid loads are usually fastened so that no movement is apparent at impact, through the use of blocking and bracing well fastened to the floor or walls, tension straps, or similar devices.

*Floating loads.*—Certain kinds of commodities, such as diesel engines, lend themselves to a floating load, which can be either a single unit or a number of units banded or wired together. Movement in the car is retarded by antiskid plates, padding, or other means. Space is usually allowed at the ends of the load for the anticipated movement. A method has been developed for placing plastic or rubber bags between the car walls and containers. When the bags are inflated, they provide the necessary cushioning.

A floating load is usually more desirable for crates than a rigid load because it lessens the shock to the item in the crate when the car is started or stopped. Rigid fastening and blocking develop high impact stresses because of the short time required to stop. Any means of fastening

a load to allow some movement will result in lower impact values because the stopping time has been increased. Cushioning of light, delicate objects has been given much study, but a great deal remains to be done on devising methods for lessening the impacts on heavy articles.

*Rigid loads.*—Rigid loads are often composed of a number of smaller packs or a miscellaneous assortment of containers that must be shipped in a closed car. Rigid loads with blocking, bracing, and strapping combinations are also used in open cars for large crates and heavy equipment. The location of bracing may depend on the load height, the crate's center of gravity, its length and width, and whether it can be wired or banded to other loads.

Cross bracing is used extensively with rigid loads in closed cars. When permissible, it should be placed edgewise against the load because it is stronger in this direction. K-bracing, a reinforcement of the cross bracing, is often used in conjunction with it where stronger bracing is required. Diagonals of the K usually extend from the center of the cross bracing to the car sides or floor or both. The ends of the cross bracing or diagonals must be held securely in place by blocks nailed to the car floor or walls to form pockets. Where possible, parts of this blocking should be nailed to an upright strut in the car sides or to a stringer in the floor even if it is necessary to use a longer block.

Center bracing is used as a width filler between containers located along the sides of the car.

Floor blocking is used along the floor to keep the load from sliding and is generally reinforced with backup cleats fastened to the floor.

An area of the sheathing in the car is sometimes covered with wall reinforcing planking nailed to the side frame members. This allows better nailing of the blocking used for cross or K-bracing.

Some tall loads may require blocking or anchoring at the top also. This is especially true of high crates or double-decked containers shipped in open cars.

Various kinds of bulkheads are used to hold loads in place, to divide them into sections, or to protect the doors of the cars when loads extend into the door area. The construction of the bulkheads varies with the weights of the loads. Bulkheads should be held in place by blocking and bracing or by metal straps anchored to the wall. Metal strapping allows some resiliency and consequently some cushioning resistance to impacts. Well-anchored strapping may require the use of some trussing between the strap and the load to distribute the pressure more uniformly. These straps should be extended along the side of the car so that tension is at right angles to the fastenings that hold the anchor plates.

The most common deficiency in car bracing is the use of too few nails. When possible, nailing

should be arranged to be under lateral displacement rather than in direct withdrawal. Nails should be driven straight into floors through the blocking, rather than diagonally through the sloping faces of the blocking.

## SHIPPING LOSSES AND INSURANCE

Under normal conditions of domestic rail shipments, material loaded in open cars is inspected by railroad representatives before the car is moved and the railroad assumes responsibility. In closed cars, however, the Association of American Railroads rules are not mandatory and are used only for guidance. Closed cars are not ordinarily inspected, but if damage occurs to the contents, they are inspected at the destination to determine the cause before a settlement is made.

Export shipping companies are specifically exempt from most forms of liabilities under the laws of many countries. The exceptions to this usually include loss or damage due to negligence in proper loading, custody, or delivery of the goods. The shipper or consignee must assume responsibility for all remaining risks during the shipment.

To prevent loss to the shipper, a form of marine insurance covers these losses. Marine insurance may be obtained to cover such perils as pilferage, theft, and leakage, as well as loss or damage if the ship should sink, burn, or be involved in a collision. However, the more hazards covered by the policy the higher the rate, so it is not economical to pay for broader protection than is actually required.

Rates in marine insurance are rather complex and are not fixed. They depend, among other things, on the type of vessel, the route, the perils insured against, the type of packing used, and the loss record of the shipper. This latter factor, of course, reflects the type of container and the method of blocking and bracing used by the shipper, because well-constructed and well-packed crates will normally receive little damage during the voyage. A shipper who uses adequate containers pays lower rates. Underwriters keep statistical records of shippers they deal with and allow lower rates for those with good records.

## TARE WEIGHT OF CRATES

In assembling crates it is necessary to have a reasonably close estimate of the tare weight in order to properly compute the number and kind of fastenings needed. The number of fastenings required to secure the sides and ends of the crate to the base is ordinarily computed for the gross

weight-weight of the contents plus the tare weight.

If a bill of material has been made, the tare weight can be found by multiplying the number of board feet of lumber in the crate by the weight per board foot for the kind and moisture content of the lumber used. An average figure, if species are not known, is 2,350 pounds per thousand board feet.

It is often desirable to know the tare weight before a bill of material is made. Any short method for estimating tare weights will depend not only on the type of crate but also on its width and height. Normally, wide crates and high crates require larger members than narrower or shallower crates.

The factors in table 36 for estimating the tare weight of crates are based on an average density and moisture content. The weights are based on a value of 2,350 pounds for a thousand board feet of lumber. If woods are denser than average, or have a higher moisture content, a slightly increased weight might be used. A slightly decreased weight might also be somewhat more accurate if the wood is less dense and quite dry. When more than one kind of wood is used some interpolation may be necessary, depending upon the different densities and moisture contents.

The following method will give a reasonably close estimate of tare weights of military-type sheathed crates. The construction of this type of crate is covered in the chapter on sheathed crates. In these estimations the total area in square feet must be determined. This includes area of top, base, ends, and sides. All dimensions should be figured to the nearest foot or half foot. Multiply this total area ( $A$ ) by the factors listed in table 36 to find the tare weight in pounds.

Use the following procedure:

Step 1—Determine area of one end,  $S$

Step 2—Determine total area of crate,  $A$

Step 3—In table 36 select the appropriate line of  $S$  values and the column of member sizes. Then multiply crate area by the factor given.

Example:

A lumber-sheathed crate with 1-inch frame members is 10 feet long and 6 feet in width and height.

The end area  $S$  equals  $6 \times 6 = 36$  square feet

The total surface area  $A$  equals:

$$2 \times 6 \times 10 = 120 \text{ (top and base)}$$

$$2 \times 6 \times 10 = 120 \text{ (two sides)}$$

$$2 \times 6 \times 6 = 72 \text{ (two ends)}$$

$$A = 312 \text{ square feet}$$

Then in the first column of table 36 the end area, 36 square feet, is between 20 and 40. Under lumber sheathing with 1-inch frame members,  $A$  is to be multiplied by 4.5.

Tare weight is then  $312 \times 4.5$  or 1,404 pounds.

TABLE 36.—*Method of estimating tare weight of military-type sheathed crates*

<i>S</i> (end area)	Weight of crate			
	1-inch lumber sheathing		3/8-inch plywood sheathing	
	2-inch framing members	1-inch framing members	2-inch framing members	1-inch framing members
<i>Sq. ft.</i>	<i>Lb.</i>	<i>Lb.</i>	<i>Lb.</i>	<i>Lb.</i>
Less than 20.....	A x 4.0	A x 3.6	A x 3.2	A x 2.9
Over 20 less than 40.....	A x 5.0	A x 4.5	A x 4.0	A x 3.6
Over 40 less than 70.....	A x 6.0	A x 5.4	A x 4.8	A x 4.3
Over 70.....	A x 7.0	A x 6.3	A x 5.6	A x 5.0

## APPENDIX III. GLOSSARY

**Air-dried.**—See Seasoning.

**Annual growth ring.**—See Ring, annual growth.

**Beam.**—A structural member transversely supporting a load.

**Beams and stringers.**—Large pieces (nominal dimensions 5 by 8 inches and up) of rectangular cross section, graded with respect to their strength in bending when loaded on the narrow face.

**Blemish.**—A marring of the appearance of wood, not necessarily a defect.

**Blue stain.**—See Stain, blue.

**Boards.**—See Lumber.

**Bow.**—Distortion of a board in which the face is convex or concave longitudinally.

**Brashness.**—A condition that causes some pieces of wood to have low resistance to shock and to fail abruptly across the grain without splintering when broken in bending.

**Broad-leaved trees.**—See Hardwoods.

**Brown stain.**—See Stain, brown.

**Cell.**—A general term for a minute unit of wood structure. Fibers, vessel segments, and other elements of diverse structure and function are cells making up fibrous and porous tissues in the wood structure.

**Check.**—A lengthwise separation of wood, the greater part of which occurs across the rings of annual growth.

**Chemical brown stain.**—See Stain, chemical brown.

**Column.**—A structural compression member, usually vertical, supporting loads acting on or near and in the direction of its longitudinal axis.

**Conifer.**—See Softwoods.

**Crook.**—Distortion of a board in which the edge is convex or concave longitudinally.

**Crossband.**—To place the grain of layers of wood at right angles in order to minimize shrinking and swelling and consequent warping; also a layer of veneer at right angles to the face plies.

**Cross grain.**—See Grain.

**Cup.**—Distortion of a board in which the face is convex or concave transversely.

**Decay.**—Disintegration of wood substance through the action of wood-destroying fungi.

*Incipient decay.*—The early stage of decay in which the disintegration has not proceeded far enough to soften or otherwise perceptibly impair the wood.

*Typical or advanced decay.*—The stage of decay in which the disintegration is easily recognized because the wood has become punky, soft and spongy, stringy, pitted, or crumbly.

**Defect.**—Any irregularity in or on wood that may lower its strength.

**Density.**—The mass of a body per unit volume. When expressed in the metric system, it is numerically equal to the specific gravity of the same substance.

**Diagonals.**—Angle members placed between vertical and horizontal members within a panel to provide rigidity to the crate. Struts and horizontal braces are so spaced that the angle of the diagonal is as near 45° as possible. In open crates diagonals are usually single; in lumber-sheathed crates they are crossed in an "X" pattern.

**Diamonding.**—A distortion in drying that causes a piece of wood originally rectangular or square in cross section to become diamond-shaped.

**Dimension.**—See Lumber.

**Dimension stock.**—Squares or flat stock, usually in pieces under the minimum sizes admitted in standard lumber grades, rough or dressed, green or dry, cut to the approximate dimensions required for the various products of woodworking factories

**Dunnage.**—In crates, blocking or timbers placed on the top of large crates to distribute the load evenly.

**Durability.**—A general term for permanence or lastingness. Frequently refers to the degree of resistance of a species or of an individual piece of wood to attack by wood-destroying fungi under conditions that favor such attack. In this connection the term resistance to decay is more specific.

**Edge grain.**—See Grain.

**End frame members.**—See Frame members.

**Encased knot.**—See Knot.

**Equilibrium moisture content.**—The moisture content at which wood neither gains nor loses moisture when surrounded by air at a given relative humidity and temperature.

**Fiber.**—A wood fiber is a comparatively long (one-twenty-fifth or less to one-third inch), narrow, tapering cell closed at both ends.

**Fiber-saturation point.**—The stage in the drying or in the wetting of wood at which the cell walls are saturated and the cell cavities are free from water. Usually taken as approximately 30 percent moisture content.

**Filler strips.**—Narrow strips of lumber used to fill in spaces between load-bearing members of the base so that the lower frame members of the sides have uniform bearing along their entire length.

**Flat grain.**—See Grain.

**Floorboards.**—Sheathing for the base. Fastened to the skids; when used to support concentrated loads, called load-bearing floorboards because they transfer the load to the edge skids.

**Frame members.**—Parts that form the fundamental structure of both sheathed and open crates. Strength and rigidity of the open crate depend entirely on these members and their fastenings.

*End frame members.*—Edge crosswise framing members of the top, located at each end of the panel.

*Intermediate members.*—Lengthwise frame members of the top, located between the side frame members. They help to resist shock, and the top sheathing is nailed to them.

*Side frame members.*—Edge framing members of a top without a joist, parallel to the length in sheathed crates. In open crates they may be called longitudinal members. Side frame members tie the framework together and may also serve as fastening members for assembly.

*Upper and lower frame members.*—Horizontal members at the top and bottom of the side and end panels. In both open and sheathed crates they frame the panels.

**Grain.**—The direction, size, arrangement, appearance, or quality of the fibers in wood.

*Close-grained wood.*—Wood with narrow and inconspicuous annual rings. The term is sometimes used to designate wood having small and closely spaced pores, but in this sense the term *fine textured* is more often used.

*Coarse-grained wood.*—Wood with wide and conspicuous annual rings in which there is considerable difference between springwood and summerwood. The term is sometimes used to designate wood with large pores, such as oak, ash, chestnut, and walnut, but in this sense the term *coarse textured* is more often used.

*Cross grain.*—Fibers not parallel with the axis of a piece. May be either diagonal or spiral grain or a combination of the two.

*Diagonal grain.*—Annual rings at an angle with the longitudinal axis of a piece.

*Edge grain.*—Edge-grain lumber has been sawed parallel with the pith of the log and approximately at right angles to the growth rings; the rings form an angle of 45° or more with the surface of the piece.

*Flat grain.*—Flat-grain lumber has been sawed parallel with the pith of the log and a proximately tangent to the growth rings; the rings form an angle of less than 45° with the surface of the piece.

*Interlocked-grain wood.*—Wood in which the fibers are inclined in one direction in a number of rings of annual growth, then gradually reverse and are inclined in an opposite direction in succeeding growth rings, then reverse again.

*Open-grained wood.*—Common painters' classification for woods with large pores, such as oak, ash, chestnut, and walnut. Also known as *coarse textured*.

*Plain-sawed.*—Another term for flat grain.

*Quarter-sawed.*—Another term for edge grain.

*Spiral grain.*—A type of growth in which the fibers take a spiral course about the bole of a tree instead of the normal vertical course. The spiral may extend right-handed or left-handed around the tree trunk.

*Vertical grain.*—Another term for edge grain.

**Green wood.**—Unseasoned, wet wood.

**Growth ring.**—See Ring, annual growth.

**Hardwoods.**—The botanical group of trees that are broadleaved. The term has no reference to the actual hardness of the wood. Angiosperms is the botanical name for hardwoods.

**Headers.**—End cross members of the base. Headers are bolted to the skids and act as fastening members for assembly of the end panels. They may also be used as reinforcing to resist forklift handling stresses at the ends.

**Heart, Heartwood.**—The wood extending from the pith to the sapwood. Its cells no longer participate in the life processes of the tree. Heartwood may be infiltrated with gums, resins, and other materials which usually make it darker and more decay-resistant than sapwood.

**Horizontal braces.**—Members ordinarily used in side and end panels of higher crates to reduce the unsupported span or height of the panels and increase crate rigidity. They are placed in the horizontal position between the upper and lower frame members.

**Inspection doors and ports.**—Small openings built into the end panel to provide access for inspection of the contents. They can be locked or sealed.

**Intermediate members.**—See Frame members.

**Joists.**—Load-supporting members of the top, spanning the width of the crate. They transfer loads to the sides and prevent the top from being crushed when the crate is handled with slings or grabhooks.

**Joist supports, vertical.**—Members fastened to the inside face of the side panels of sheathed crates to support the ends of the joists.

**Kiln-dried.**—See Seasoning.

**Knot.**—Part of a branch or limb that has become incorporated in the body of a tree.

*Decayed knot.*—A knot which, due to advanced decay, is not so hard as the surrounding wood.

*Encased knot.*—A knot whose rings of annual growth are not intergrown with those of the surrounding wood.

*Intergrown knot.*—A knot whose rings of annual growth are completely intergrown with those of the surrounding wood.

*Round knot.*—A knot whose sawn section is oval or circular.

*Sound knot.*—A knot that is solid across its face and as hard as the surrounding wood.

*Spike knot.*—A knot sawn lengthwise.

**Lag screw—reinforcing strap.**—Prepunched strapping of annealed steel. It is nailed to the inside of the sheathing at the bottom fastening areas of the side and end panels of demountable crates. It reinforces the sheathing and increases the lateral-withdrawal resistance of the assembly lag screws.

**Laminated wood.**—A piece of wood built up of plies or laminations that have been joined with either glue or mechanical fastenings. The term is most frequently applied if the plies are too thick to be classified as veneer and the grain of all plies is parallel.

**Liner.**—Asphalt-impregnated or laminated paper or similar material, used in the sides, ends, and sometimes the tops of lumber-sheathed crates to keep moisture out.

**Lower frame members.**—See Frame members.

**Lumber.**—The product of the saw and planing mill not further manufactured than by sawing, resawing, and passing lengthwise through a standard planing machine, crosscut to length, and matched.

*Dressed size.*—The dimensions of lumber after shrinking from the green dimension and being planed, usually  $\frac{3}{8}$  inch less than the nominal or rough size. For example, a 2 by 4 strut actually measures  $1\frac{5}{8}$  by  $3\frac{5}{8}$  inches. See Lumber, Nominal size.

*Factory and shop lumber.*—Lumber intended for further manufacture. It is graded on the basis of the percentage of the area from which a limited number of cuttings of a specified or minimum size and quality can be made.

*Matched lumber.*—Lumber dressed and shaped to make close tongue-and-groove joints at the edges or ends when laid edge to edge or end to end.

*Nominal size.*—As applied to timber or lumber, the rough-sawn commercial size by which it is known and sold in the market. See Lumber, Dressed size.

*Rough lumber.*—Lumber as it comes from the saw.

*Surfaced lumber.*—Lumber that has been dressed by running it through a planer.

*Yard lumber.*—Lumber less than 5 inches thick intended for general building purposes.

*Board.*—Yard lumber less than 2 inches thick, 1 inch or more in width.

*Dimension.*—All yard lumber except boards, strips, and timbers (yard lumber at least 2 inches but less than 5 inches thick, of any width).

*Strip.*—Yard lumber less than 2 inches thick and less than 4 inches wide.

692-318 O-64-9

**Moisture content of wood.**—Weight of the water contained in the wood, usually expressed in percentage of weight of the oven-dry wood.

**Pitch pocket.**—An opening between or within annual growth layers in softwoods usually containing, or which has contained, pitch, either solid or liquid.

**Pith.**—The small soft core in the structural center of a log.

**Plain-sawed.**—See Grain.

**Plywood.**—Three or more layers of veneer joined with glue, usually with the grain of adjoining plies at right angles. Almost always an odd number of plies is used for balanced construction.

**Preservative.**—Any substance that, when suitably applied to wood, makes it resistant to wood-destroying fungi, borers of various kinds, and similar destructive life for a reasonable length of time.

**Quarter-sawed.**—See Grain.

**Radial.**—Coincide it with a radius from the axis of the tree or log to the circumference.

**Ring, annual growth.**—The growth layer put on in a single growth year, including springwood and summerwood.

**Rotary-cut veneer.**—See Veneer.

**Rubbing strips.**—Strips of wood, usually 2 inches thick, nailed to the underside of each skid as spacers to allow sling lifting of the crate from the ends and forklift handling from the sides.

**Sapwood.**—The wood next to the bark, usually of lighter color than the heartwood, one-half inch to 3 or more inches wide, actively involved in the life processes of the tree. Under most conditions sapwood is more susceptible to decay than heartwood and as a rule, more permeable to liquids. Sapwood essentially is neither weaker nor stronger than heartwood.

**Sawed veneer.**—See Veneer.

**Seasoning.**—Removing moisture from green wood in order to improve serviceability.

*Air-dried or air-seasoned.*—Dried by exposure to the air, usually in a lumberyard, without artificial heat.

*Kiln-dried.*—Dried in a kiln with artificial heat.

**Shake.**—A separation along the grain, the greater part of which is between the rings of annual growth.

**Sheathing.**—The covering, usually of boards or plywood, placed over the frame of a crate. It serves to tie the frame members into a panel and aids the diagonals and struts of the sides and ends in supporting superimposed loads.

**Sheathing paper.**—A liner material used to keep moisture out.

**Side frame members.**—See Frame members.

**Sills.**—The members that, along with the sill bridging, form the framework of sill-type bases. Sills carry loads and transfer them to side panels and serve as fastening members.

**Sill bridging.**—Members of the same depth as the sills, inserted at right angles to the intermediate sills to prevent the sills from turning or buckling.

**Skids.**—Lengthwise members of the base. They help to support the load and serve as fastening members for flooring, headers, and the side panels.

**Sliced veneer.**—See Veneer.

**Softwoods.**—The botanical group of trees that have needle or scalelike leaves and, except for cypress, larch and tamarack are evergreen. The term has no reference to the actual hardness of the wood. Softwoods are often referred to as conifers, and botanically they are called gymnosperms.

**Span.**—The distance between supports, such as structural members.

**Specific gravity.**—The ratio of the weight of a body to the weight of an equal volume of water at some standard temperature.

**Springwood.**—The part of the annual growth ring formed early in the season's growth. It is usually less dense and mechanically weaker than summerwood.

**Stain, blue.**—A bluish or grayish discoloration of the sapwood caused by the growth of certain moldlike fungi on the surface and in the interior, made possible by the same conditions that favor the growth of other fungi.

**Stain, brown.**—A rich brown to deep chocolate-brown discoloration of the sapwood in some pines caused by a fungus that acts similarly to the blue-stain fungus.

**Stain, chemical brown.**—A discoloration of wood that sometimes occurs in several species during air or kiln drying, apparently caused by the oxidation of extractives.

**Strength.**—The term in its broader sense embraces all the properties of wood that enable it to resist forces or loads. In its more restricted sense it may apply to any one of the mechanical properties, and the name of the property should be stated, as strength in compression parallel to the grain, strength in bending, etc.

**Structural timber.**—Wood of relatively large size for which strength is the controlling element in selection and use.

**Struts.**—Frame members placed vertically between upper and lower frame members.

**Summerwood.**—The part of the annual growth ring formed during the latter part of the yearly growth period. It is usually more dense and mechanically stronger than springwood.

**Tangential.**—Strictly, coincident with a tangent at the circumference of a tree or a log, or parallel to such a tangent. In practice, however, it often means roughly coincident with a growth ring.

**Tare weight.**—Weight of the container itself, as well as the blocking, bracing, and cushioning.

**Twist.**—A distortion caused by the turning or winding of the edges of a board so that the four corners of any face are no longer in the same plane.

**Upper frame members.**—See Frame members.

**Veneer.**—Thin sheet of wood.

*Rotary-cut veneer.*—Veneer cut in a continuous strip in a lathe by rotating a log against the edge of a knife.

*Sawed veneer.*—Veneer produced by sawing.

*Sliced veneer.*—Veneer cut by moving a log, bolt, or flitch against a knife.

**Vertical joist supports.**—See Joist supports, vertical.

**Vertical grain.**—See Grain.

**Wane.**—Bark or lack of wood from any cause on the edge or corner of a piece of lumber.

**Warp.**—Any variation from a true or plane surface. Warp includes bow, crook, cup, and twist.

**Weathering.**—The mechanical or chemical disintegration and discoloration of the surface of wood caused by exposure to light, the action of dust and sand carried by winds, and the alternate swelling and shrinking of the surface fibers as they gain and lose moisture during changes in the weather. Weathering does not include decay.

**Wood preservative.**—See Preservative.

**Workability.**—The degree of ease with which wood can be cut or shaped with hand or machine tools, and the smoothness of cut obtainable.

**Yard lumber.**—See Lumber.

## INDEX

- Adhesives, use of, 13, 22
- Advantages of good design, 1
- Anchoring crates, 121
- Assembly:
  - general, 13
  - open crates, 53, 60
  - sheathed crates, 43, 45, 48
- Balance point, 120
- Base construction:
  - general, 2, 29
  - open crates, 51, 53, 59
  - sheathed crates, 32, 45, 46
- Basic stresses, 10
- Bill of lading, 120
- Bill of material, 123
- Blocking and bracing, 122
- Bolts, 21
- Bridging, 35
- Bulkheads, 122
- Cable handling, 76
- Car impacts, 121
- Carloading crates, 121
- Cautionary marks, 120
- Center bracing, 122
- Center of balance, 120
- Checks and splits, 10
- Columns:
  - intermediate, 27
  - long, 28
  - short, 27
- Compression members, 27
- Connectors, 21
- Contents, 2
- Cornerwise drop test, 79
- costs, 4
- Crates (general):
  - Construction, 1
  - contents, 2
  - costs, 4
  - definition, 1
  - design, 2, 23
  - dimensions, 2, 4
  - handling hazards, 2
  - importance, 1
  - open, 4, 50
  - requirements, 2
  - selection, 2, 4
  - sheathed, 4, 32
  - storage conditions, 4
  - transportation, 2
  - weight, 4
- Cross bracing, 122
- Decay, 10
- Demountability, 2, 19, 21, 22
- Design, 1, 2, 23
- Design principles, 24
- Destination, 2
- Diagonals:
  - importance, 24
  - strength, 12
- Disassembly, 2
- Displacement, 4
- Drop tests, 78
- Dunnage, 31, 74, 76
- Duration of load, 9
- Edgewise drop test, 78
- Effective span, 24
- End construction:
  - open crates, 51, 53, 60
  - sheathed crates, 39, 45, 46
- End struts, 37
- Euler formula, 27, 28
- Exports, 121
- Fabrication:
  - general, 13, 18
  - open crates, 51, 53, 59
  - sheathed crates, 32, 45, 46
- Fastenings:
  - adhesives, 22
  - bolts, 21
  - lag screws, 19
  - nails, 13
  - steel strapping, 22
  - timber connectors, 21
  - wood screws, 22
- Floating loads, 122
- Floor blocking, 122
- Floorboards, 9, 30, 73
- Flexure formula, 29
- Forklift:
  - handling, 78
  - headers, 29
- Frame members, 28
- Framing test, 74
- Freight classification, 121
- Glues, 22
- Grabhooks:
  - damage, 3
  - handling, 78
  - reinforcing joist, 31, 43
- Grain, slope of, 9
- Handling:
  - hazards, 2, 3
  - tests, 76
- Headers, 29, 35
- Identification marks, 120
- Impact loading, 10
- Insect attack, 10

- Intermediate columns, 27
- Intermediate sills, 30, 34
- Joists, 9, 31, 41
- Knots, 9, 10
- Lag screws, 19
- Light-duty type:
  - open, 59
  - sheathed, 46
- Like-on-like loading, 4, 31
- Limited-military type:
  - open, 53
  - sheathed, 45
- Loading in cars, 122
- Loads:
  - floating, 122
  - general, 29
  - rigid, 122
  - top testing, 76
- Long columns, 28
- Longtime loading, 11
- Lumber sizes, 11
- Marine insurance, 123
- Marking crates, 120
- Materials for crates:
  - costs, 4
  - fastenings, 13
  - paper overlay, 13
  - plywood, 11
  - wood, 5
- Members:
  - compression, 27
  - cross, 29
  - determining size of, 27
  - tension, 27
- Military type:
  - open, 50
  - sheathed, 32
- Modulus of elasticity, 27
- Moisture content, 9, 10, 15
- Moment:
  - maximum bending, 29
  - of inertia, 29
- Nailing patterns, 18
- Nails:
  - calculating nail-holding capacity, 14
  - clinching, 16
  - direction of driving, 15
  - penetration, 15
  - points and heads, 15
  - rules for use, 17
  - sizes, 13, 15
  - surface condition, 15
  - types, 13
- Open crates:
  - general, 1, 4, 50
  - light-duty, 59
  - limited-military, 53
  - military type, 50
- Packing lists, 120
- Panel member sizes, 52, 80
- Paper-overlaid veneer, 13
- Partial disassembly, 2
- Pendulum impact test, 74, 79
- Plywood, 11
- Racking resistance, 3
- Reduction factors, 11
- Rigid loads, 122
- Rough-handling tests, 74
- Rubbing strips, 35, 76
- Screws, 22
- Section modulus, 29
- Shakes, 10
- Sheathed crates:
  - general, 1, 4, 32
  - light-duty, 46
  - limited-military type, 45
  - military type, 32
- Sheathing thickness, 27
- Shipment, 2, 32, 50, 120
- Shipping loss:
  - insurance, 123
  - prevention, 121
- Short columns, 27
- Shrinkage, 6
- Side construction:
  - open crates, 51, 53, 59
  - sheathed crates, 37, 45, 46
- Sills, 29, 30, 35
- Skid assemblies, 68
- Skids, 24, 29
- Slenderness ratio, 27
- Sling handling, 3, 76, 120
- Slope of grain, 9, 10
- Species of wood, 5
- Specific gravity, 6
- Splicing, 35
- Splits, 10
- Stacking, 4, 31
- Stain, 10
- Storage conditions, 4
- Strapping, 22, 122
- Stress diagram, 26
- Struts, 28
- Style A and A-1 open crate, 52
- Style B open crate, 52
- Style C open crate, 54
- Superimposed load tests, 74
- Tare weight, 123
- Tension members, 27
- Testing crates:
  - drop, 78
  - general, 73
  - handling, 76
  - impact, 79
  - superimposed-load, 74
- Timber connectors, 21
- Timber truss, 26
- Top construction:
  - general, 31
  - open crates, 53, 60
  - sheathed crates, 41, 45, 46
- Top load tests, 74, 75

- Truss diagram, 26
- Types of loads, 122
- Ventilation, sheathed crate, 40
- Wane, 10
- Warping, 10
- Weather conditions, 2, 4, 41, 50
- Weight-length value, 68
- Withdrawal resistance:
  - lag screws, 19
  - nails, 16
- Wood:
  - blue stain, 10
  - checks and splits, 10
  - decay, 10
  - density, 5, 15
- Wool-Continued
  - duration of load, 9
  - insect attack, 10
  - knots, 9
  - moisture content, 5, 9, 15
  - shakes, 10
  - slope of grain, 9
  - strength, 5
  - wane, 10
  - warping, 10
- Wood species:
  - properties, 6
  - strength and variability, 5, 10, 15
  - weight, 5
- Working stresses, 10