



Saskatchewan
Ministry of
Agriculture



PRODUCTION

Rat Control in Saskatchewan



F A C T S H E E T

Rat Control in Saskatchewan

RATS!

The **Norway rat** (*Rattus norvegicus*), also known as the brown, common or sewer rat, is the most common species of rat found on the Canadian Prairies.

It is not native to North America, but is believed to have been introduced by early settlers to the continent when their ships docked on eastern shores. Like almost every other introduced or exotic animal species, the Norway rat spread and became a serious problem.

Rats followed the westward movement of settlers and reached the Great Lakes during the early 1900s. In the summer of 1950, the first recorded rat colony in Alberta was discovered on a farm near Alsask on the Saskatchewan border.

Saskatchewan's Rat Control Program began with the introduction of

The Fieldworker Policy in 1972. Grants are provided through the Fieldworker Policy to the Saskatchewan Association of Rural Municipalities' Provincial Rat Eradication Program (PREP) for the control of rats.

The rat is recognized as the most destructive vertebrate in the world, both in terms of economic losses and the transmission of disease.



The rat is recognized as the most destructive vertebrate in the world, both in terms of economic losses and the transmission of disease.

Losses caused by rats can be divided into three categories:

- Contaminated foodstuffs;
- Physical damage caused by gnawing and tunneling; and
- Disease transmission.

These topics are discussed in detail on page two.

Responsibility for rat control

In Saskatchewan, the Norway rat has been declared a pest under provisions of *The Pest Control Act* and Regulations.

Provincial responsibility for the administration of the rat control program lies with the Provincial Rat Eradication Program (PREP). However, *The Pest Control Act* clearly identifies that the responsibility

for controlling and destroying pests resides with every person who owns land and buildings, occupies land and buildings, or controls land.

Rural municipalities can pass bylaws requiring every resident within the rural municipality to take all appropriate measures to destroy, control and prevent the spread of rats and other pests.

Acknowledgments

This fourth printing of Rat Control in Saskatchewan has been sponsored through the Provincial Rat Eradication Program (PREP). The content has been revised in 2012 in cooperation with Saskatchewan Agriculture (SA). Copies of this book are available by contacting local Pest Control Officers.

Personnel of various government agencies and universities, farmers, contractors, commercial firms and many others contribute information for use in Saskatchewan Agriculture publications. Space limitations do not permit credit to each source. We thank all contributors and reciprocate by offering this publication for public benefit.

© Saskatchewan Agriculture

Losses due to contaminated foodstuffs

Rats consume and contaminate approximately one-fifth of all the world's field crops planted each year, including at least four per cent of all stored grains.

A rat eats about 10 per cent of its weight each day, some 20-40 kg (10-20 lb.) a year. A rat contaminates five to 10 times the food it eats with its urine and feces.

Ontario surveys estimate that rodents annually cost the Ontario poultry industry about \$2 million and the swine industry \$6.4 million. Ontario reported damage in many forms including the following:

- Destruction of insulation. Many poultry and swine facilities show serious deterioration within five years of being built. Associated with this damage are costs for re-insulation, increased energy costs and reduced feed conversions by animals.
- Contaminated feed. A rat produces 25,000 droppings a year; a mouse 17,000 a year.
- Structural damage to wood and wiring.
- The Ontario study indicates a single rat will eat, spoil or damage \$25 worth of grain a year.

Physical damage caused by gnawing and tunneling

Common types of damage caused by gnawing and tunneling include:

- Extensive gnawing damage to buildings and structures caused by rats constructing elaborate food-access routes, nest sites and escape routes;
- Particularly destructive to granaries and other food and feed storage facilities;
- Allowing cold air entry through gnawed holes, increasing frost heaving in the structures of buildings;
- Undermining of foundations and walls;
- Destruction of wall and ceiling insulation causing increased fuel consumption, increased condensation that shortens the life of building materials, and increased cold stress on livestock;
- Gnaws through lead pipes, plastic hoses, conduits of all types, and electrical wiring.

Disease transmission

Rats, which by their nature live and breed in human



Holes chewed in wooden bins by rats.

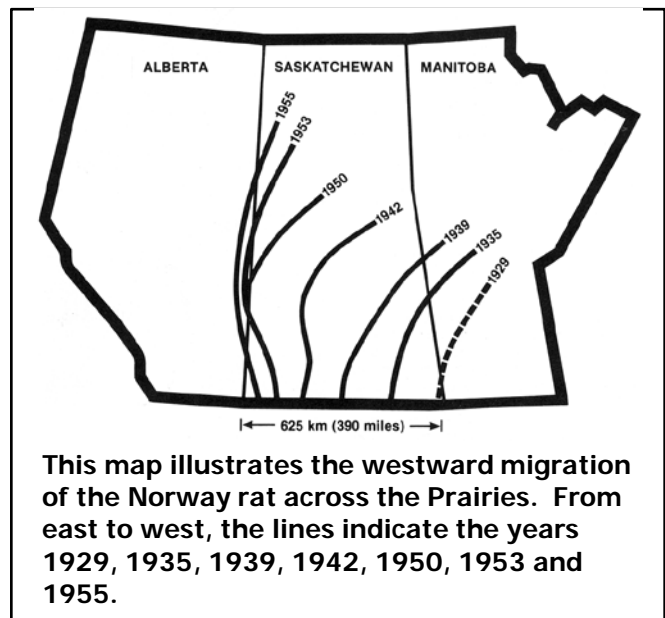

garbage and sewers, have the potential to act as high transmitters of disease. Hundreds of rat bites, most unreported, are believed to occur in Canada each year. Only occasionally do rat bites cause serious illness, but all rodent bites should be promptly and carefully cleaned and disinfected. Tetanus immunization or booster shots are recommended. Rabies and Hantavirus are not considered threats as rats have never been found naturally infected with the causative virus.

Rats can transmit disease, either directly by contaminating food and feeds with their urine, feces and other body secretions, or indirectly, by rat fleas or mites.

An example of a rat transmitted disease is toxoplasmosis.

Toxoplasmosis is a parasite of rats. This parasite can be transmitted to humans and livestock by the domestic cat, which is infected by eating infected rats.

Toxoplasmosis is most dangerous to pregnant women, causing malformation, retardation or death in the fetus. Rats infected with this parasite were found in a Guelph, Ontario study in 1977.

Rats!

They fought the dogs and killed the cats,
And bit the babies in the cradles,
And ate the cheeses out of the vats,
And licked the soup from the cooks' own ladles,
Split open the kegs of salted sprats,
Made nests inside men's Sunday hats . . .

— Robert Browning,
from *The Pied Piper of Hamelin*, 1842.

Biology and behaviour of the Norway rat

The Norway rat is prolific and adaptable. It thrives in most man-made environments. In fact, it lives off humans, making excellent use of unprotected food storage and dwellings; uncollected garbage; improper waste disposal; grain spills; and unpiled lumber and debris.

The Norway rat can survive on a wide range of food items from domestic garbage, rotten meat and fish, stale grain, green feed, straw, fresh fruits and vegetables, packaged foods, sugar and candies.

Life history of the Norway rat

Rats are born in a nest 21 to 23 days after conception. Females can mate again within a day or so of littering. The gestation period, in this case, may be a few days longer than normal.

The size and number of litters depend on and vary with habitat restrictions, availability of nutritious food, density of local rat population and age of the female rats. Norway rats have large litters (12 to 18 young per litter). Under ideal conditions, Norway rats can reproduce up to 12 times per year. It has been estimated that, under ideal conditions, a single pair of Norway rats could produce 15,000 offspring in one year.

Newborn rats are naked and their eyes are closed. They mature rapidly, growing hair within a week. At nine to 14 days, their eyes open and they begin to explore for food near the nest. In the third week, they begin to explore for solid food, even though they may continue to nurse until four or five weeks old. By this time, they have learned a good deal about what is good to eat by experimenting with potential food and by imitating their mother.

Young rats cannot generally be trapped until about one month of age. At this time, the Norway rat weighs about 35 grams (1.5 ounces). At about three months of age, the young are completely independent of the mother and are reproductively mature. The females come into heat (estrus) every four or five days and remain receptive to males for a day or two.

Bubonic Plague

Plague is an infectious disease of animals and humans caused by a bacterium named *Yersinia pestis*. People usually get plague from being bitten by a rodent flea that is carrying the plague bacterium or by handling an infected animal. Millions of people in Europe died from plague in the Middle Ages, when human homes and places of work were inhabited by flea-infested rats.

Today, modern antibiotics are effective against plague, but if an infected person is not treated promptly, the disease is likely to cause illness or death. Globally, the World Health Organization reports 1,000 to 3,000 cases of plague every year. In North America, plague is found in certain animals and their fleas from the Pacific Coast to the Great Plains, and from southwestern Canada to Mexico.

(Source: Centers for Disease Control and Prevention at www.cdc.gov/)

Identification of the Norway rat

Weight

The adult Norway rat weighs an average of 450 grams (one pound); females weigh slightly less.

Length

Body length varies from 18 to 25 centimeters (seven to 10 inches).

Tail

The most distinguishing feature of true rats is the tail. The Norway rat's tail is cylindrical or round, tapering and nearly hairless. The hairs on the tail are short and bristle-like and grow out from well defined hairline ridges along the entire length of the tail. The length of the tail is about 15 to 22.5 centimeters (six to nine inches) and is almost as long as the body.

Nose and ears

The Norway rat's snout is blunt. The ears are thick and short, with fine hairs.

Fur colour

The colour of the fur on the back and sides of the Norway rat can be a grizzled reddish to grayish brown, or completely black. The underbody fur is tinged gray to yellowish-white. White rats and white-spotted rats are sighted on occasion. They are believed to result from albino rats or released laboratory specimens. All varieties of white and other-coloured laboratory rats stem from the wild Norway rat and will readily cross with the wild rats.



The most distinguishing feature of true rats is the tail, which is about six to nine inches in length and almost as long as the body.

Nesting behaviour of the Norway rat

The Norway rat lives at or near ground level. It nests and burrows in the ground, under buildings, particularly poultry and livestock shelters, feed facilities, granaries, and under bale stacks. The rat burrows are also often found at the base of rubbish piles, garbage dumps, sewers and septic tanks, as well as lumber piles.

Nests are usually shallow, less than a third of a meter or one foot deep. They are horizontal and simply constructed with one or more exits or "bolt" holes. The burrows are usually about a meter (three feet) in length, but can be quite complex and extensive in areas where burrowing is easy, or in piles of debris where natural spaces already exist. In these places, burrows often reach a depth of one meter.



Norway rats have large litters of 12 to 18 young. Under ideal conditions, Norway rats can reproduce up to 12 times per year, with the young becoming reproductively mature at about three months of age. Given these numbers, it has been estimated that a single pair of Norway rats can generate 15,000 offspring in one year.



Rat burrow under a shed



Rats often nest in the wooden floors of steel granaries.

Senses of the Norway Rat

Sight

Rats see poorly, relying more on smell, taste, touch and hearing. They are considered to be colour blind, responding only to the degree of lightness and darkness of colours. Thus, for safety reasons, baits can be made with bright colours, like red, without affecting their acceptability to rats.

Smell

Rats use their keen sense of smell to locate food and apparently to recognize other rats, especially those of the opposite sex. More research is needed to determine the value of various odours either as attractants or repellents. Rats usually do not shy away from the smell of humans on food, traps or baits.

Taste

Taste perception of Norway rats is good. They can easily detect certain toxic compounds at extremely low levels (0.5 parts per million or ppm) in their diets. Once they have tasted a food item, taste overrides odour.

Hearing

Rats recognize noises and use their acute hearing to detect and escape danger, but more research is needed on how much their activity is affected by noise. Ultrasound devices advertised for frightening rats from buildings lack sufficient supportive research data.

Touch

An important sensory factor with rats is touch. The long, sensitive whiskers (vibrissae) near their nose and the guard hairs on their body are used as tactile sensors. It is why rats are rarely seen in the open.

Balance

Rats have excellent balance. Like a cat, a falling rat lands on its feet. A Norway rat can drop as much as 15 meters (50 feet) without being killed or seriously injured.

Physical abilities

Burrowing and gnawing

Rats can burrow vertically 1.25 meters (four feet). They can gnaw through lead pipe, brick, cinder blocks, aluminum sheeting, plastics, glass and electrical wiring. Rats can gain entrance to a building through any opening that is larger than 1.25 cm (1/2 inch) in diameter.

Climbing

The Norway rat can climb quite well when necessary. When rat proofing a structure, it would be wise to consider that the Norway rat can:

- Climb both horizontal and vertical wires;
- Climb the inside of vertical pipes that are four to 10 centimeters (1.5 to four inches) in diameter;
- Climb the outside of vertical pipes up to 7.5 centimeters (three inches) in diameter;
- Crawl horizontally on any type of pipe or conduit, and along power lines;
- Climb brick or other rough exterior walls which offer footholds, to gain access to upper stories of structures.

Jumping and reaching

Norway rats can jump vertically as much as one meter (36 inches) from a flat surface. They can jump 1.2 meters (48 inches) horizontally. They can reach as much as 33 centimeters (13 inches) along smooth vertical walls.

Swimming

Norway rats are good swimmers. They can swim up through floor drains and toilet bowl traps. They can swim as far as 0.8 km (a half mile), dive through water plumbing traps and travel in sewer lines, even against substantial water currents.



Rats consume and contaminate approximately one-fifth of all the world's field crops planted each year, including at least four per cent of all stored grains.

Behaviour of the Norway Rat

Feeding habits

Rats are omnivorous: they eat nearly any type of food, although each colony of rats has its own preferences. Rats are nocturnal; they begin their search for food shortly after sunset and are rarely seen in daytime, unless hungry or overcrowded. If rats, even one or two, are seen in daytime, it is a sign of an overpopulated rat colony, a sure sign of a serious rat infestation.

If the food is in an exposed area or too large to be eaten quickly, the rats will carry or drag the food to a hiding place before eating. Rats will cache or hoard considerable amounts of food.

Water requirements vary with diet, but most rats drink water regularly if it is available. In the winter months, rats will eat ice and snow. Where there is no water, rats are believed to obtain moisture from green vegetation and dew.

Social behaviour

Rats can be very aggressive with their own kind, especially when overcrowded. Dominant males exclude other males from the burrow, which may be occupied by several females. This is one major cause of rat migration. Rats in the colony tend to separate themselves socially into distinct hierarchies or social orders. These orders are determined largely by fighting. The more dominant rats occupy the better habitats and feed wherever and whenever they like, whereas the less dominant rats occupy the less suitable habitat and feed when the dominant rats are not present. Again, migration occurs when all suitable habitat is occupied. This accounts in part for rats being seen in daylight.

Reaction to strange objects

Rats are suspicious and will often avoid strange objects, sounds and other changes in their environment for three or more days. The rat recognizes a trap or poison bait as a new object to be avoided. Unfamiliar sounds, or even a familiar object moved to a new location, will cause avoidance, or a noticeable drop in feeding. In environments where strange objects appear regularly, such as at garbage dumps or warehouses, rats show little evidence of being suspicious or of avoidance behaviour.

When a rat crosses a street,
everyone shouts and beats it.
-- Chinese proverb.

Recognizing a rat infestation

The following sections describe major signs of a rat infestation.

Burrows

An early sign of a rat infestation is a new burrow. While rats will nest in double walls and under floors, they prefer to live in shallow burrows under foundations, scrap piles or feed stacks. Note that a rat burrow does not have loose dirt around the entrance as does the Richardson ground squirrel burrow. The entrance to a rat burrow is about four to eight centimeters (1.5 to three inches) in diameter. Burrows in use are free of dust and cobwebs. Old burrows should be closed after control of a rat population to prevent migrating rats from re-establishing.

Rats prefer to construct their burrows at the base of a vertical surface such as the side of a building, a pile of debris or in a ditch bank. They sense the security of a firm roof over their heads. Burrows are invariably located within 100 feet of the rat's food and water supply, and, frequently, located even closer.

Rat runs

Since rats use primarily the sense of touch rather than sight to find their way, and since a rat population has definitely marked territory, an infestation can be detected by the well beaten trails, or rat runs, between their nests and food and water sources.

Smudge marks

Rats, having very oily skin and using their sense of touch to move around, leave oily smudge marks which build up along walls and uprights. Look particularly under roofing beams where the beams abut against main joists.

Droppings and urine stains

Rat "scats" or droppings are capsule shaped (blunt ends) and approximately 20 mm (3/4 inch) in length and six mm (1/4 inch) in diameter. They are easily distinguished from mouse droppings, which are much smaller and have pointed ends. Fresh rat droppings are black, shiny and soft. After a few days they become mouldy or dull black and hard. Old droppings are dull gray. Look along walls in dark or protected areas, or around food and water sources. A single rat produces 25,000 droppings a year, about 125 a day. If both small and large droppings are present, it indicates that the population is actively breeding. Rat urine fluoresces under ultraviolet light.



Typical rat burrows, above and below.



Gnawing

Rat teeth grow at the phenomenal rate of 12 to 15 cm (4 3/4 to six inches) a year. Rats must gnaw constantly to wear their teeth down. Look for fresh signs of gnawing around doors, windows, cracks, knot holes, exposed edges of boards and concrete. Fresh gnawings on wood are light coloured and show distinct teeth marks two to four mm (1/16 - 1/8 inches) wide. Look for fresh wood chips.

Tracks

The presence of fresh tracks on dusty surfaces, such as in grain dust, or on wet soil after a rain, or in fresh snow, is a sure sign of an established rat population. Rat tracks are distinct from other rodents. The front imprint is four-toed while the back imprint is five-toed. The "thumb" of the front foot is higher up the leg. The hind footprint is about two to 2.4 cm (3/4 to one inch) long, but may be shorter if the rat is running. Flour or talc may be spread along walls to detect an infestation or check for complete control.

Sounds

Rats may be heard at any time of day, but most commonly just after dusk. Noises of gnawing, scurrying about, fighting and squealing are common.

Odours

A well established rat population has a characteristic odour. Rats have a musty odour in comparison with the pungent odour of mice.

Visual sightings

When rats become overpopulated or overcrowded, they relax their secretive habits and maternal care because of increased competition for food and harbourage. Rats normally begin their activities at dusk, but, when overpopulated, they continue throughout the night with the weak and less dominant rats feeding in daylight. Therefore, as has been said, if rats are sighted in the daytime, it is a sign of a serious rat infestation.

Pet excitement

One of the first signs that a migrant rat has entered the premise is often a dog barking or probing a wall, foundation, scrap pile or bale stack. Investigate promptly, even though there is the possibility that it is a false alarm. Once a population becomes established, dogs often become indifferent.

Nests and food caches

Rat nests are concealed in secure and protected places such as between double walls, under floors and granaries. Overpopulated rats will nest in unusually exposed areas. Look for signs under junk piles, stone or wood piles or waste straw. Occasionally, rats can be found on upper floors of buildings. Large food caches may also be common. Watch for quantities of pet food, bones and other dry food stuffs stored in secluded locations.

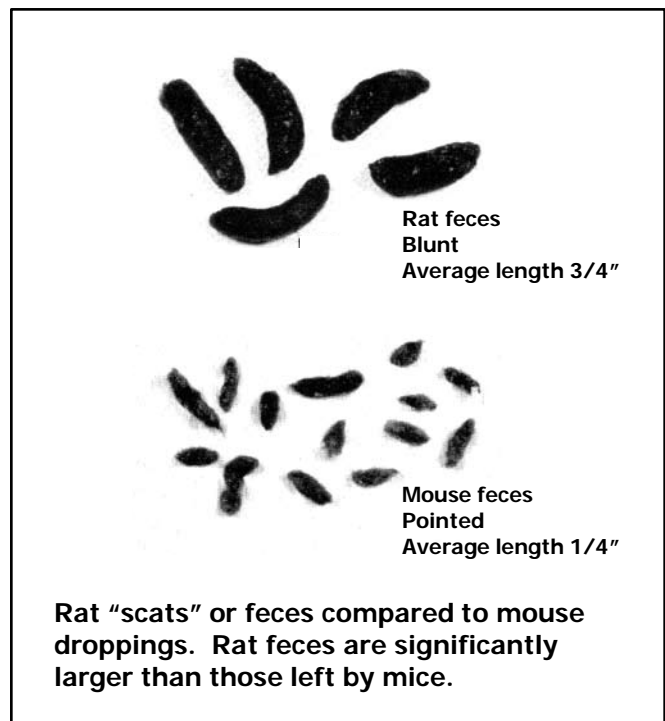

A rat eats, then leaves its droppings.
-- Hawaiian saying



Preventative rat control measures

There are four steps in a rat control program:

1. Poisoning, trapping and/or fumigating rat populations;
2. Permanent bait stations;
3. Cleanup of harbourage and food/water sources; and
4. Rat-proofing.

Each step is essential. If these steps are not

followed, the control program ultimately breaks down and the investment for the individual resident and for the community is wasted.

Without a concerted effort by the community in the four-step program, the complete control of rats on a municipal and provincial basis becomes impossible and the individual resident is left having to constantly poison in-migrating rats.

Rat Control Step 1: Poisoning, trapping and/or fumigating rat populations

Rodenticides or ready-to-use baits

Baits are available in many formulations. Anticoagulant baits are formulated as loose meal, pellets of all sizes and colours, and paraffinized blocks, which are useful in damp locations.

Bait formulations have changed over the years. Pelletized rodent baits are common today, although they do not appear to be more effective than the loose meal types. Colours have been added to baits which prevent accidental mixing of the poison with food.

It is important to recognize that certain bait formulations may be, for no apparent reason, accepted in some locations and not others. It is good practice to place two or three types of formulations as a means of determining the preferred bait. Baits should be stored in tightly closed containers to prevent contamination by odours or insects, and to preserve freshness.

Multiple-dose (chronic) poisons

Over 90 per cent of rat control operations in North America incorporate multiple-dose (anticoagulant) poisons. Most of these poisons must be consumed over a number of days to produce death. Anticoagulants act by interfering with blood clotting, and death results from internal or sometimes external bleeding. Death, after the rats consume the treated food over a period of three to 10 days, is relatively painless.

Warfarin has the longest history of use on the farm. These poisons are relatively safe because they are



less potent and take a period of time to produce death.

In general, anticoagulants are relatively safe for humans and non-target animals. The onset of poisoning is relatively slow, and when accidental ingestion of the anticoagulant poison occurs, there is time for the antidote Vitamin K, or for a blood transfusion, to be administered. A large, single dose of the older-type anticoagulant such as warfarin will usually not kill a healthy animal.

Failure of anticoagulant treated baits (even if bait is readily accepted and consumed) could be due to one or more of the following reasons:

- Baiting is not carried out over enough days and weeks.
- Insufficient anticoagulant in bait or replenishment of anticoagulant in bait is too infrequent.
- Too few bait stations are used, or are not spaced close enough together. In some situations, stations may have to be within seven to 10 meters (20-30 feet) of one another.
- The preventative control and control program is not



community-wide and migrating rats from uncontrolled areas re-infest your property.

- Some rats may be less susceptible to the anticoagulant. An inherited anticoagulant-resistance may have developed to anticoagulants that have been used for many years. This prospect is unlikely but should be considered, especially if about the same amount of bait is eaten daily for a number of weeks. Substitute with bromadiolone or brodifacoum.
- The food in the bait is a poor choice, or the bait is formulated improperly.
- Rats are finding other food sources.
- The bait has become moldy, rancid, insect-ridden or contaminated with other material which reduces acceptance. Discard old baits periodically and replenish with fresh bait.
- The bait station is strategically located in the wrong place.

Water baits

Rats will drink water daily if it is available. Rats require at least 30 ml (one ounce) of water each day to survive. Where access to water is restricted or water is naturally limited, water baits can be very effective.

Caution is recommended with water baits:

Since water is consumed by non-target animals, water baits should be used only where other animals cannot gain access to them. Water baits, used with dry baits, make bait stations especially appealing to rats. Rats will accept water from an unfamiliar source long before they will accept dry bait. Plastic chick-type fountains which hold one or two quarts of water are ideal for dispensing anticoagulant water bait in permanent bait stations. Even unpoisoned water can be used to attract rats to bait stations, especially if other food sources are abundant.

Fumigation

Fumigation can be used to control rats in burrows or under floors of out-buildings. Fumigating is usually confined to structures where the poisoning methods are impractical, ineffective or hazardous. It could be the only control method available where bait acceptance is poor or nil due to other easily accessible food sources.

Fumigants are highly toxic, therefore, extreme caution must be taken to ensure humans, animals and plants are not exposed to the fumes. When fumigating, evacuate adjacent buildings. Burrows should not be gassed if they are less than 20 feet (6.1 metres) from an inhabited building. There is the chance that burrows

could lead to openings in the building and, therefore, fumigant could leak into the building.

Sulphur dioxide cartridges, which may be used without a licence or permit, are available for use in rat burrows. They should be lighted and inserted as far as possible into the rat burrow, and the entrance plugged with dirt. Because of possible fire hazard, the cartridges should not be used under buildings with wooden floors, unless the cartridges are placed in a length of stovepipe or similar protective shield.

Several highly toxic fumigants are available for eradicating rats. These toxicants are restricted to trained, licensed applicators. Even so, they are not recommended for use in the Prairie provinces.



Many types of rodenticides are available.

Trapping

Trapping can be effective in controlling rats, but it requires more skill and labour than the baiting method. However, trapping is the preferred method in homes, garages, and small structures where there are very few rats. There are advantages:

- No hazardous poisons are used.
- Trapping permits the user to inspect his success.
- Trapping eliminates rat deaths in inaccessible locations in dwellings, which frequently create odour problems when poisoning is done.

Rats rely on concealment for protection, avoiding open spaces as much as possible. Therefore, the best places to set traps are close to walls, behind objects, in dark corners, and along runways. Set traps where

signs are found. Traps should be set so that the rat, in following its natural course, will pass directly over the trigger. For example, in setting along a wall, the trap should extend from the wall at right angles, with the trigger end nearly touching the wall.

Rats will, without setting off the trap, frequently remove bait which is not secured to the trigger. Baits should be fastened securely to the trigger with light string, thread or fine wire, so that when attempting to remove it, the rat will be sure to spring the trap. Traps should be set so the trigger is sensitive and will spring easily.

The type of bait used to trap Norway rats is very important. Small pieces of hot dogs, bacon or other prepared meats secured tightly to the trigger are the best choice, but they must be replaced every day or two to keep them fresh. Peanut butter has been found to work well.

As in the case with poisoning rats, when there is an abundance of food, it makes trapping much more difficult. Before starting a trapping campaign, eliminate sources of accessible food.

Traps can be used unbaited if the trap is placed directly in the rat's path with the trigger situated to intercept rats coming from either direction (see diagrams). Expanded treadle-type triggers are available, or a piece of cardboard can be used to enlarge the trigger on a conventional snap trap. In difficult cases, a trap can be placed slightly below ground level and lightly dusted with fine soil or fine material to conceal it.

Human or dead rat odours do not cause a reduction in catch. But, rats may set traps off without getting caught. If ever a trap is found set off but no rat is caught, you can be sure you will never catch that rat with a trap again.

The most effective trap: the snap trap

The simple "rat snap" is the most effective.

It can be used unbaited by placing it in the rat's runway, directly in the rat's path.

If traps are baited, always secure the bait with thread or string, and replace the bait regularly to keep it fresh.

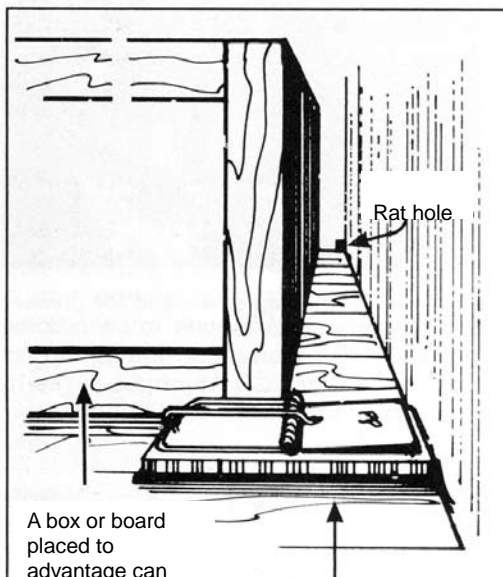

Place traps across obvious runways or where runs are confined.

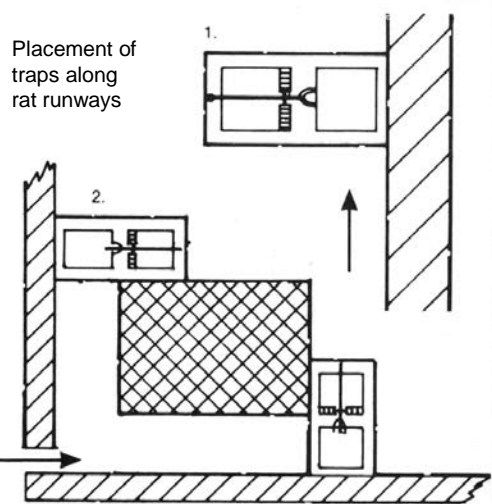
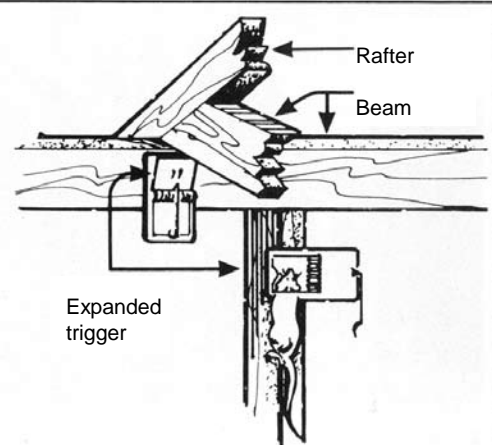
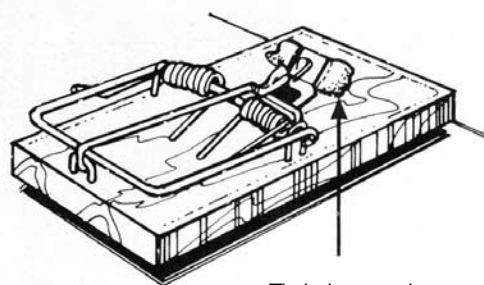

Glue boards

Where toxicants may not be possible or desirable, glue boards are gaining in popularity. Pest control officers are often using them with, or in addition to, trapping.

Glue boards are simply a base or shallow tray of paper, cardboard or plastic, coated with a non-toxic, sticky substance. These traps are strategically placed along rat runs where rats, in passing, are likely to step on the surface of the glue board. The rat rarely escapes, although glue boards are more successful for mice than the Norway rat. Glue boards do, however, have some useful application for indoor rat control. They are not effective in dusty environments, such as granaries.

Glue boards have the advantages of traps with the additional advantage of being safe to use around children and pets.

Ultrasonic devices

Ultrasonic devices produce high frequency sounds above normal hearing range of humans, but well within the range of rats and mice. The devices are promoted to rid premises of rats. However, usually loud sounds, including high frequency sounds, will frighten rats, causing them to avoid the sounds, but only temporarily, rarely permanently. Rats rapidly become accustomed to sounds and frequencies, whether fluctuating, variable pitch, or used at random intervals.

There are problems with ultrasound devices which limit their usefulness:

- They are very directional and do not travel through solid objects or around corners well, thus "shadows" are created.
- The sound does not travel very far as it attenuates, or dissipates, rapidly.
- The unit cost is high. Several units are usually required.
- There is variability between models.
- The ultrasonic devices should be used with rodenticides for effective lasting control.

With proper use of rodenticide baits, there are few situations where the additional cost of ultrasonic devices is warranted.

Electromagnetic devices

There is no scientific evidence to support claims by manufacturers. For this reason, no electromagnetic device has been granted registration for rat control in Canada.



Rats cannot effectively be controlled by either native or introduced predators.

Biological control

Rats cannot effectively be controlled by either native or introduced predators. That vertebrate predators can control rats and mice is a myth

The fact is that there is far more evidence that predator numbers are regulated by the number of prey, rather than vice versa. Even though house cats and some dogs may kill rats, they do not reduce the numbers for effective control. Under some circumstances, however, cats may help prevent migrating rats from re-infesting rat-free property. It is not uncommon, though, to find rats living in close association with cats and dogs.

Frequently rats can be found living under a doghouse and feeding on the dog food when the dog is asleep. In fact, many rat problems around the home can be directly correlated with the keeping of pets.

Rat Control Step 2: Permanent bait stations

Bait stations which are closed and locked give rats the security to feed. The bait inside the station is protected from the elements. Humans, especially children, and non-target animals are protected from accidental poisoning.

The bait station should be constructed large enough to accommodate several rats at a time. Each station should have at least two openings, approximately six to seven cm (2.5 inches) in diameter. The station can contain a self-feeder hopper for holding the bait. Some stations may be large enough that both dry and water baits can be placed inside.

Bait stations can be boxes which are available commercially in a variety of sizes and shapes and

constructed from wood, weather-resistant cardboard and plastics. Homemade boxes can be constructed to fit the location. They should be made from old lumber or discarded materials as rats will be less likely to shy away from them. Since rats are wary, they may not readily accept a new bait station for several days.

Boxes are generally more effective than open bait trays or feeders except in special situations where baits are confined to locked or controlled buildings, and inaccessible to children and pets.

A simple bait station can be made by leaning a wide board against a wall or fence. It will shelter rats when feeding and, with both ends open, give rats several avenues of escape. But, it is important that the station be inaccessible to children and pets. The ends of the entire bait station should be enclosed with large-mesh chicken wire to keep children and domestic animals out while letting rats in.

Various types of homemade bait stations

Whatever method is used, it is imperative that baits be inaccessible to children, pets, livestock and wildlife.

A homemade rodent bait station can contain liquid as well as solid baits.

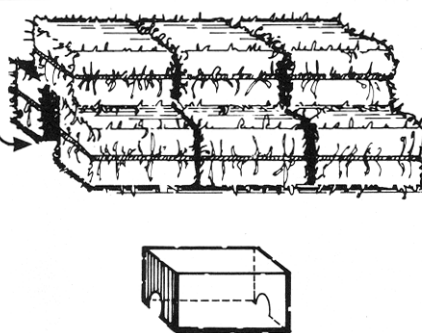
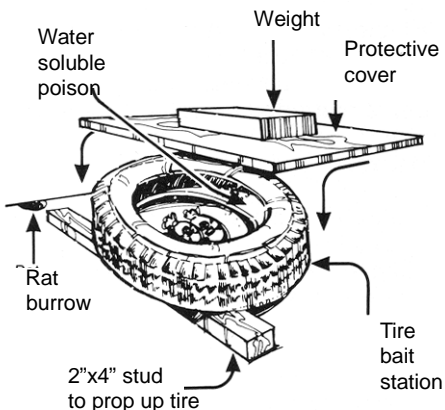
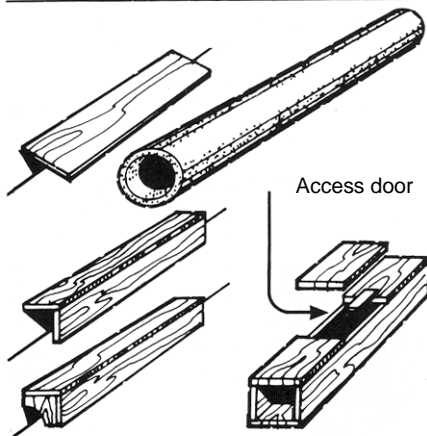
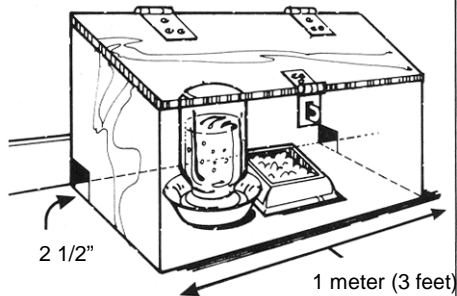

Bait stations and other baiting sites should be clearly labelled **RAT POISON** and exhibit a poison warning label bearing the skull and crossbones, the international symbol for poison.

An old tire can be used as bait station for dry and water soluble baits. Allow access for rats by propping the tire on one side, cover the tire and weight down the cover to protect children and pets.

When first put out, bait stations should be checked daily. After a while it will be necessary to check the stations only once every other week, or once a month, to replenish bait. It depends on the infestation. What is important is that there is a supply of fresh anticoagulant bait.

Important:

Baits, wherever possible, should be placed and covered in bait stations. Whatever method is used, it is imperative that baits be inaccessible to children, pets, livestock and wildlife. Bait stations and other baiting sites should be clearly labelled RAT POISON and exhibit a poison warning label bearing the skull and crossbones.

Bait placement

- Proper placement of bait stations can be as important as the type of bait used. Place bait stations in or near rat harbourages, near rat burrows, along rat runs and/or food/water sources. Do not expect rats to go out of their way to obtain the bait, even if they will occasionally. The best placement of bait stations is along rat runs between harbourages and food sources.
- When baiting burrows, put the bait deep into the burrow. Baits must be contained in their original packaging or bags, unopened, which prevents spoilage caused by moisture and insects. The burrow should then be covered to prevent access by children and non-target animals.
- Feedstacks provide excellent winter shelter and a food source for rats. Unopened bait bags should be placed inside the stack margin at ground level, every six to 10 meters (20-30 feet). Hay bales should be spaced. In old bale stacks, place baits inside existing gaps in the stack, well out of reach of livestock.
- Routinely inspect baits to ensure they are not insect infested, moldy or otherwise unattractive to rats. Restock baits as necessary. Remove dead rats, using gloves or shovel, and bury the carcasses.
- It is imperative to keep bait stations stocked with fresh food and water anticoagulant bait where rats are accustomed to feeding. There should be an uninterrupted supply of bait for a period of not less than 15 days. Continue baiting until all signs of feeding have stopped.
- Under-baiting, particularly with an acute toxicant, leads to bait shyness, which then becomes difficult to overcome.
- Permanent bait stations must be placed at key

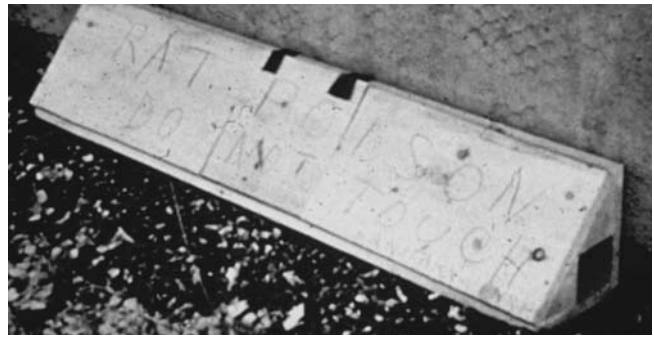

A bait station, marked RAT POISON, DO NOT TOUCH, and placed, ideally, against a wall where the rats will run.

locations to intercept new rats from migrating in and establishing on a rat-free site. Migrant rats, especially in spring and fall, will readily occupy vacant nests and rapidly reproduce. In no time, the rat-free site can become re-infested.

***Safety precautions
and legal implications***

- Anticoagulant rodenticides are potentially dangerous. They can cause death to humans and non-target animals. Be sure to place rodenticide baits where they are inaccessible to children, pets, livestock and wildlife.
- Bait placements should be labelled with warning signs. A record should be kept of bait placements, including location, quantity, type of poison, dates placed and replenished. The name of the pest control officer should be recorded.
- Use only registered anticoagulants.
- Wherever possible, it is best to buy prepared or ready-to-use anticoagulants. Anticoagulants prepared by the pest control officer may not be given or sold to the public.
- Anticoagulants should be handled with rubber gloves.
- Label bait stations and placement with warning signs. Store poisons in original containers which bear registered labels.
- Store and lock unused anticoagulants away from the reach of children and away from food. Mark storage location with warning sign. Access to the stored anticoagulants should be restricted to authorized persons.
- Vehicles used to transport rodenticides must be kept locked and have a visible warning sign indicating chemicals are being transported.
- Bury dead rats immediately. Avoid handling rats with bare hands.

Rat Control Step 3: Clean up of harbourage and removal of food and water sources

Sanitation is the basis of a long-term rat control program.

Poor disposal of food wastes and poor storage of food and grains invites rats to move in and infest the farm. A step to controlling rat and mice infestations is the storage of food wastes in rodent-proof containers, the collection and disposal of waste, and the proper storage of usable food and feed.

Probably the greatest food source for rats on the prairie farm is spilled grain, or poorly stored grain. It is important to clean up spilled feed and grains, especially around buildings and granaries where rats find harbourage.

Clean up vegetables and debris from gardens in fall. Make pet foods, such as dog and cat foods and bird seed, inaccessible to rats. Rat-proofing bird feeders is useful.

Garbage, a source of food, water and harbourage to rats, must be stored for collection in covered rat-proof containers with tight fitting lids. Bulk waste containers (dumpsters) may be required for commercial operations.

Garbage must be collected and disposed of in municipal "sanitary" landfills. Open garbage dumps are major producing grounds for flies and rats that may migrate to adjacent towns and farms.

The following sanitary landfill practices of garbage disposal should be used so that rat infestations can be controlled.

- Use the "open-pit" method for disposal of waste.
- Separate waste into food and non-food pits.
- Where permitted, burn combustible wastes as often as possible, observing local regulations regarding the burning of wastes which produce noxious fumes.
- Bagging food wastes should be used as an alternative to burning.
- The disposal of animal carcasses should be prohibited.
- Garbage should be compacted and covered with approximately 60 cm (two feet) of earth. Large urban centres do this daily. Smaller towns and rural disposal sites should compact and bury food wastes as frequently as possible, at least two or three times each year, more frequently if burning is prohibited in the municipality;

- For long-term management, it is advisable to fence the disposal site and to lock the gates to regulate authorized access and proper disposal.

Feed storage

- Feed and food should be stored in rat-proofed bins and granaries. (See section on rat proofing). When emptied, bins and granaries should be cleaned.
- Bagged feed should be stored 45 cm (18 inches) off the floor and 45 cm (18 inches) away from walls. Leave 60 cm (24 inches) aisles between pallets.
- Construct feed bunks and water troughs so they do not provide a food and water source for rats. The space between the ground and self-feeders or feed bunks should be filled with compacted, coarse gravel. The perimeter of feeders and bunks should be sealed off with rat-proof hardware cloth or metal to keep rats from entering.
- Inspect bulk silage storage on a regular and routine basis to prevent a rat infestation.
- Do not store forage bales near buildings. Do not use them for insulation.
- Check lofts where feed or hay is stored.

Sanitation cannot be emphasized too strongly for it is the basis of a long-term rat control program.

Rat proofing self feeders

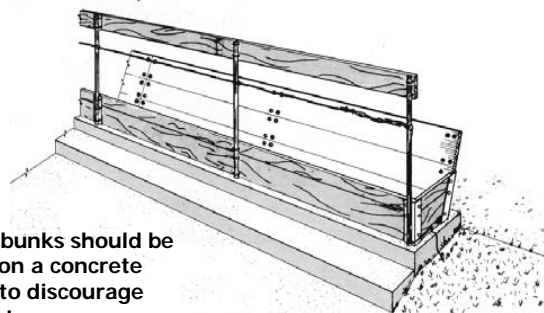

Feed bunks should be built on a concrete base to discourage rodents.

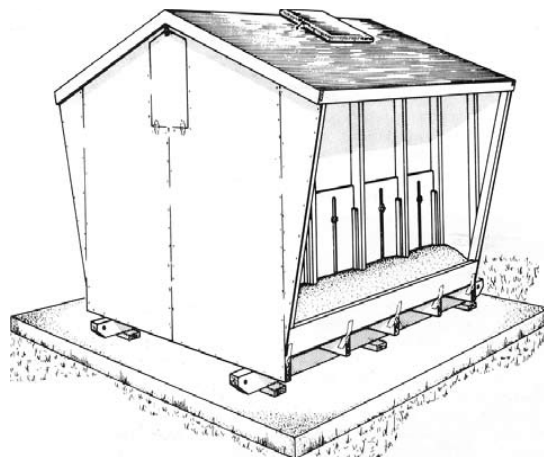

Portable self-feeders cannot be made rodent-proof, but they can be put on a concrete pad and blocked up to discourage nesting underneath.

Removal of harbourage

The next step in a preventative long-term rat control program is the reduction and removal of harbourage. Rats cannot survive and reproduce if they do not have protective shelter and nesting sites.

Rats use runways which are sheltered by tall grass, shrubs and rubbish to avoid detection. They nest, well-protected and undisturbed, under woodpiles, piles of junk and in old dilapidated houses and granaries.

- Destroy nesting sites, burrows and hiding places.
- Since rats shy away from open, exposed areas, clean up debris and junk piles, reduce the potential for harbourage and unexposed runways between their harboured nests and food source.
- Clean up trash, old cars and machinery.
- Pile lumber and other building materials and machinery at least 45 cm (18 inches) off the ground and away from walls.
- Cut weeds and grass, particularly around buildings and structures where rats might harbour.
- Keep trees and shrubs trimmed so they do not provide unexposed runways for rats.
- Drain standing water near buildings and cover water sources.

These preventative measures should be routine for effective long-term control. Constantly inspect for renewed rat infestations.

Rat Control Step 4: Rat proofing *“Build them out”*

A permanent measure of rat control is to “build them out,” that is, make it impossible for rats to gain entrance to harbourage and food.

Rat-proof food where it is stored, processed, prepared and fed to livestock. Deny rats access to harbourage. If rats are denied access to food and harbourage, they cannot survive.

Remember, rats have four incisor teeth which grow 10-15 cm (4-6 inches) a year. They must gnaw each day to keep their teeth short enough to eat. They can exert a pressure of 24,000 pounds per square inch. Given a hold and unexposed harbourage, they can chew through most building materials.

Siding

Run corrugated steel siding horizontally. Corrugated metal running vertically can leave open ends at the foundation, providing a place for rats to work their way

inside the walls. For existing metal buildings, seal these open ends with metal flashing or mortar.

Doors and windows

Doors, windows and screens should be tight fitting. Reduce gaps to less than three mm (1/8 inch) to prevent both mice and rats from entering. Fit doors with metal kick plates set close to door edges to prevent rats and mice from gnawing holes in the doors.

Drains and conduits

In drains, use screens with holes smaller than 12 mm (1/2 inch). Keep these screens in good repair. Tightly seal areas where utilities enter buildings.

Insulation

Seal sandwich wall panels all the way around the building to keep rats and mice out of the insulation. Protect perimeter insulation on the outside of the foundation with a covering such as asbestos cement board, high density fibreglass or reinforced plastic. This material should extend 95 cm (3 feet) below the surface of the ground.

Foundations

Construct concrete floors and foundations of high quality materials. Where foundations cannot be completely rat proofed or where an earth floor exists, build a curtain wall.

Inside the building

- Fill potential nesting holes, that is, holes six mm (1/4 inch) or larger, with rat-proof materials such as concrete, mortar or sheet metal.
- Eliminate hiding places such as under stairways.
- Attach a 46-cm (18-inch) width of sheet metal to climbable rough walls, 90 cm (36 inches) from the floor.
- Install wiring on the visible side of the interior lining of the ceiling and walls where rats are less likely to gain access and where coverings can be easily observed for rat damage.
- Fill the openings around pipes and conduits with masonry, sheet metal or hardware cloth.
- Cover door edges with sheet metal to prevent rats from gnawing.
- Cover ventilation duct openings with hardware cloth or expanded metal grills with openings no larger than 12 mm (1/2 inch). These should be set in metal frames. Ensure that ventilation is not restricted. There are a number of materials recommended for repair work.

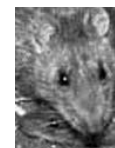

See diagram over page for rodent-proof, insulated, stud walls.

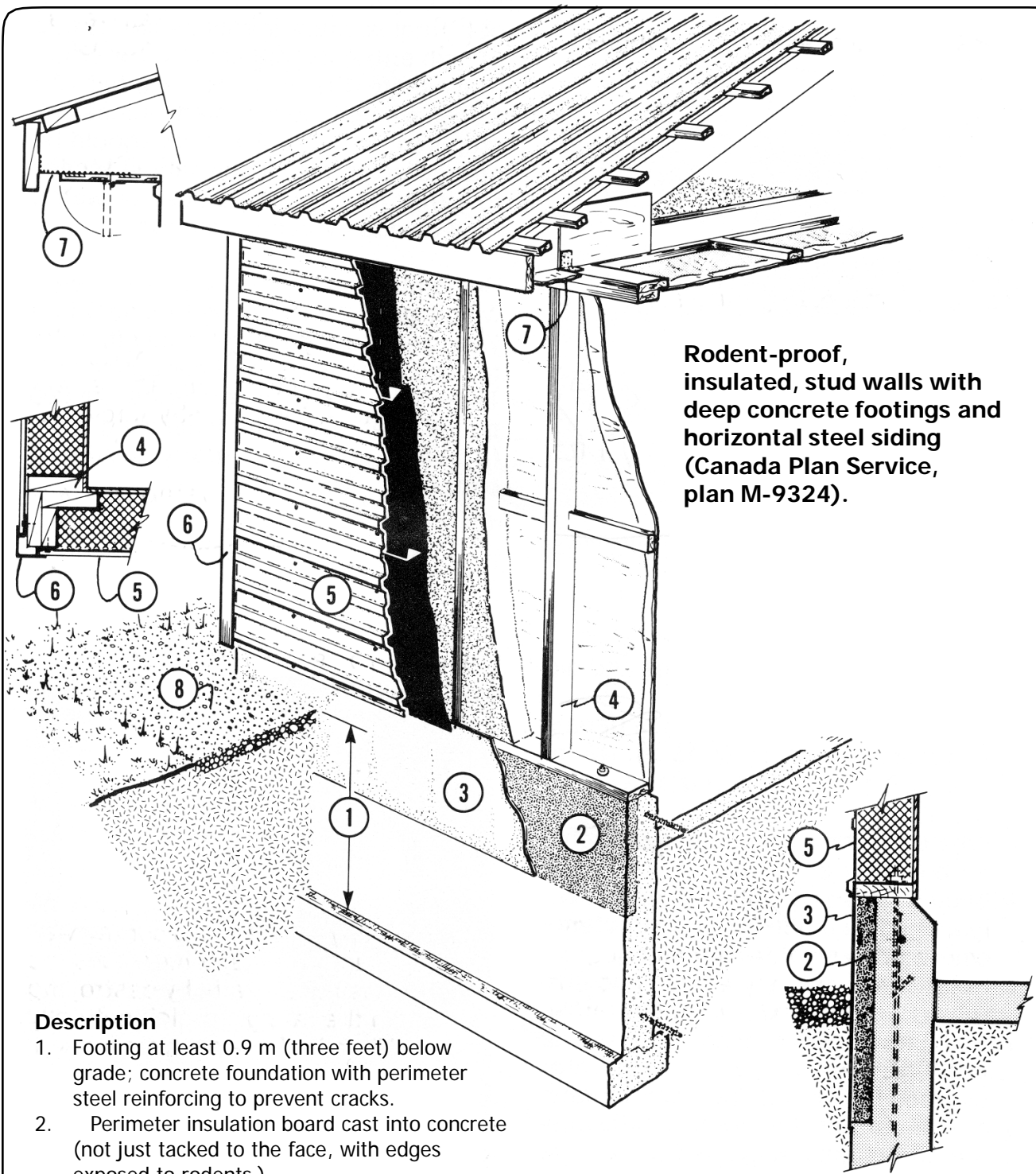

Rodent-proof, insulated, stud walls with deep concrete footings and horizontal steel siding (Canada Plan Service, plan M-9324).

Description

1. Footing at least 0.9 m (three feet) below grade; concrete foundation with perimeter steel reinforcing to prevent cracks.
2. Perimeter insulation board cast into concrete (not just tacked to the face, with edges exposed to rodents.)
3. Five mm (1/4 inch) high-density cement-asbestos board, cut 50 mm (two inches) wider than #2, drilled and screwed tightly to wood sill.
4. Wood studs full width of wall frame, each stud space a separate compartment.
5. Horizontal galvanized steel siding, lapped over and screwed through #3.
6. Steel corner cap closes ends of the steel siding #5.
7. Soffit air inlet with 12 x 12 mm (1/2-inch mesh)

8. Gravel splash pad (no grass or weeds next to walls).

PROVINCIAL RAT ERADICATION PROGRAM (PREP)

Saskatchewan Association of Rural Municipalities

Regina, SK S4P 2E1

PHONE: (306) 761-3736 TOLL FREE: 1-866-667-3604 FAX: (306) 565-2141

WEBSITE: www.prep.sarm.ca

SASKATCHEWAN AGRICULTURE

3085 Albert Street, Regina, Saskatchewan, CANADA S4S 0B1

PHONE: 1-866-457-2377

WEBSITE: www.agriculture.gov.sk.ca



Saskatchewan Association
of Rural Municipalities



Saskatchewan
Ministry of
Agriculture

Revised July 2012

5M ISBN 0-88656-692-0

Crops Branch, Ministry of Agriculture