

REVIEW ARTICLE

The last common bilaterian ancestor

Douglas H. Erwin^{1,*} and Eric H. Davidson^{2,*}

¹Department of Paleobiology, National Museum of Natural History, Washington, D.C. 20560, USA

²Division of Biology 156-29, California Institute of Technology, Pasadena, CA 91125, USA

*Authors for correspondence (e-mail: erwin.doug@nmnh.si.edu or davidson@caltech.edu)

Accepted 11 April 2002

SUMMARY

Many regulatory genes appear to be utilized in at least superficially similar ways in the development of particular body parts in *Drosophila* and in chordates. These similarities have been widely interpreted as functional homologies, producing the conventional view of the last common protostome-deuterostome ancestor (PDA) as a complex organism that possessed some of the same body parts as modern bilaterians. Here we discuss an alternative

view, in which the last common PDA had a less complex body plan than is frequently conceived. This reconstruction alters expectations for Neoproterozoic fossil remains that could illustrate the pathways of bilaterian evolution.

Key words: Protostome-deuterostome ancestor, Metazoan phyla, Developmental evolution, Gene regulation, Conserved sequences

INTRODUCTION

The Bilateria are divided into two great clades, the protostomes and deuterostomes. The nature of the last common ancestor of protostomes and deuterostomes is a problem of enormous interest, not only for understanding where we came from, but also because it affects our views of the developmental regulatory systems of modern animals. Arguments from paleontology, gene regulation molecular biology and phylogenetics intersect at this problem. But the striking advances in all of these areas the last few years require that our image of the last common protostome-deuterostome ancestor (PDA) evolve as well.

Many recent discussions adopt the view that the last common PDA was an animal essentially similar in complexity to modern bilaterians (e.g. De Robertis and Sasai, 1996; Coates and Cohn, 1998; Holland, 2000; Holland, 2002; Carroll et al., 2001; Kimmel, 1996). This view reflects the amazing conservation of genetic apparatus that has been discovered across the Bilateria, particularly of genes encoding transcription factors and signaling molecules. The apparently homologous expression of these genes in both insects and vertebrates has generated the view that the morphogenetic developmental programs generated by these regulatory molecules are conserved characters, and that the relevant body parts of insects and vertebrates may therefore be considered homologous. This reasoning has recently been applied to a number of patterning and morphological features. Pan-bilaterian processes of anterior differentiation, dorsoventral (DV) patterning, eye development, peripheral and central nervous system development, cardiac development, gut regionalization, segmentation and appendage formation and

patterning have all been proposed as conserved developmental mechanisms that were already being utilized in the PDA. But all of these proposed homologies necessitate a PDA of very complex morphology, an animal equipped with head, eyes, heart, segmentation, appendages, anteroposterior (AP) and DV differentiation and a host of other advanced characteristics.

There are two primary difficulties with this view, one having to do with developmental regulatory principles and the other with paleontological evidence. First, for many developmental regulatory systems there is no convincing evidence that it is specific morphogenetic pathways per se that are conserved, rather than cell-type specification and differentiation processes. Second, to put the matter in a nutshell, the paleontological problem is that a morphologically complex PDA would very likely have left traces of its presence in the relatively well-studied fossil record of the Neoproterozoic. A complex variety of bilaterian forms is present in the Cambrian, which begins at 543 Mya (million years ago) (Grotzinger et al., 1995), but there is an enigmatic absence of fossil evidence that can be related to a likely PDA in older rocks. The oldest convincing remains of bilaterians are fossils of an already well-developed animal, *Kimberella*, which we discuss below, and of various bilaterian trace fossils. These date back only to about 555 Mya (Martin et al., 2000), i.e., the latest Neoproterozoic. Furthermore, molecular clock estimates of bilaterian divergence indicate much older dates. Despite various potential problems with molecular clock estimates (Smith and Peterson, 2002), most of these suggest that the age of the latest PDA must lie much deeper in time than the latest Neoproterozoic. Depending on the proteins, calibration points and rate substitution models used, these estimates range from 600 to 1200 Mya (Wray et al., 1996; Ayala et al., 1998; Bromham et al., 1998; Gu, 1998;

Cutler, 2000). The most general argument, independent of molecular clock extrapolations, is that given the diversity of crown group bilaterians already present in the Early Cambrian, bilaterian stem group ancestors, including the PDA, must be significantly more ancient than the Cambrian boundary; and they should also predate *Kimberella*.

Here we discuss the PDA from two perspectives: the paleontological and geological data; and the growing evidence from comparative developmental studies. We propose an alternative view of the PDA, an animal much more simply constructed than is customary in current treatments. Fossilization of this animal might require rare special circumstances, and unless prior expectations are suitably adjusted, its fossils might not be recognized as such even if found.

CHANGING VIEWS OF THE PDA

The distribution of shared anatomical characters across Bilateria determined views of the PDA in the period prior to the introduction of phylogenetics. In many traditional topologies, various acoelomate and pseudocoelomate groups were placed as stem group bilaterians basal to the remaining Bilateria. In such topologies the origin of the Bilateria predates the PDA, as illustrated in Fig. 1A. Four distinct speculations on the plesiomorphic condition of the Bilateria were advanced: the common ancestor was a microscopic, acoelomate, turbellarian-like worm (i.e., like a simple flatworm), with ciliary locomotion and direct development (Boaden, 1989; Platt, 1980), perhaps similar to modern, millimeter-sized bilaterian meiofauna (for example rotifers); or it was a microscopic, acoelomate or pseudocoelomate, pelagic form (Cohen and Massey, 1983; Nielsen, 1985; Nielsen and Nørrevang, 1985); or it was a coelomate, macroscopic form that lived on the sea floor (benthic), perhaps with a larval stage and perhaps segmented (Clark, 1979; Bergström, 1989; Collins and Valentine, 2001); or it was a bilaterian that possessed both larval and adult stages (see Jägersten, 1972), with ciliary locomotion in the microscopic larva and a macroscopic, coelomate, filter-feeding adult (Rieger et al., 1991).

The metazoan relationships demonstrated by molecular phylogenetics are very different, as shown in Fig. 1B (Aguinaldo et al., 1997; de Rosa et al., 1999; Adoutte et al., 2000; Peterson and Eernisse, 2001). Among the most important changes are the transfer of the acoelomates and pseudocoelomates to within the protostomes; the recognition of two great protostome subclades, the ecdysozoa and lophotrochozoa, and the alliance of annelids with molluscs and other lophotrochozoans rather than with arthropods (ecdyszoa). The position of the acel flatworms within the lophotrochozoa was challenged based on a 18S rDNA analysis (Ruiz-Trillo et al., 1999). However, much further analysis of rDNA phylogeny as well as of Hox gene sequences and of morphological characters clearly places the flatworms within the lophotrochozoa, and the acels within the flatworms (Adoutte, 2000; Berney et al., 2000; Littlewood et al., 2001; Peterson and Eernisse, 2001).

The revised topology of Fig. 1B has fundamentally altered inferred morphological homologies among the Bilateria, and in consequence has affected interpretations of conserved

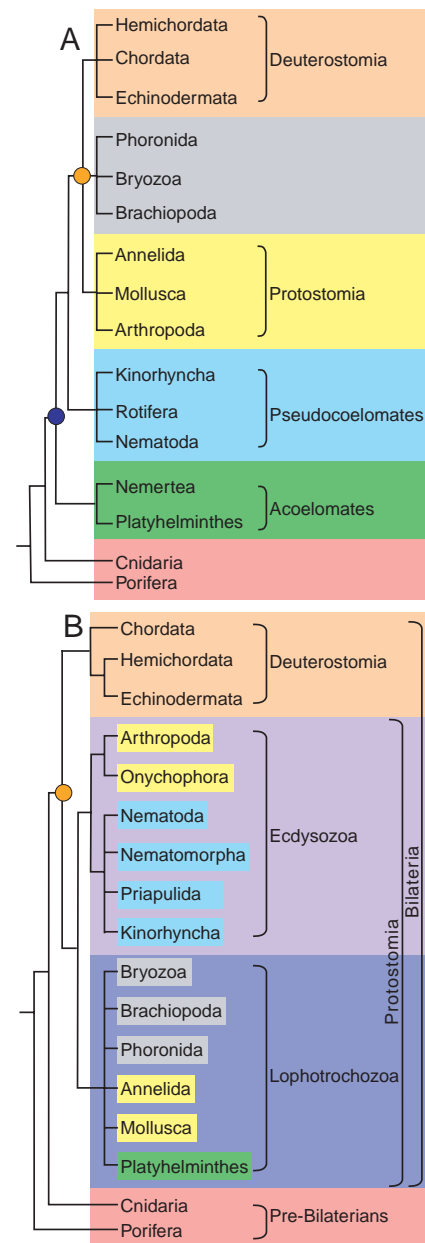

Fig. 1. New and old views of metazoan phylogeny. (A) A representative metazoan phylogeny pre-1995 showing the division of metazoa into the diploblasts, acoelomates and pseudocoelomates, and the coelomate protostomes and deuterostomes; note the intermediate position of the lophophorate phyla. (B) A more recent metazoan phylogeny with the acoelomate and pseudocoelomate taxa distributed among the two great protostome subclades, the lophotrochozoa and the ecdysozoa.

developmental programs. For this discussion the most significant change is that the last common PDA is now also the last common bilaterian ancestor. This in turn has generated renewed speculation as to the nature of the PDA (e.g. Scott, 1994; Schenk and Steele, 1994; Davidson et al., 1995; De Robertis and Sasai, 1996; Erwin, 1999; Valentine et al., 1999; Carroll et al., 2001; Hausdorf, 2000; Holland, 2000; Peterson et al., 2000; Peterson and Eernisse, 2001).

THE 'MISSING' FOSSIL RECORD

What can paleontological evidence of the period before the Lower Cambrian boundary tell us about the last common PDA, or at least what possibilities might it permit us to exclude? Paleontologists have extensively explored vast areas of the Neoproterozoic (1000-543 Mya) fossil record, including a variety of marine environments and styles of preservation. Particular types of fossils are restricted to particular environments of fossilization. The Neoproterozoic fossil record includes abundant microfossils, trace fossils (tracks and burrows), and a variety of algal remains. The absence of bilaterian fossils prior to the very end of the Neoproterozoic, at least so far, does not mean that bilaterians did not exist then, but it does place meaningful constraints on their possible nature.

Body fossils and evidence from molecular biomarkers has established the presence of numerous crown-group eukaryote lineages between 1200 Mya and 740 Mya, including green and red algae, dinoflagellates, ciliates and testate amoebae (which form fossilizable chambers) (Butterfield, 2000; Porter and Knoll, 2000). The most diverse and heterogeneous fossils from this interval are resistant, organic-walled microfossils known as acritarchs, which increased greatly in diversity during the Neoproterozoic (Knoll, 1996; Vidal and Moczyłowska-Vidal, 1997; Xiao and Knoll, 1999; Zhou et al., 2001). Many new acritarch groups appeared during the earliest Cambrian (Vidal and Moczyłowska-Vidal, 1997), perhaps linked to the origination of zooplankton (Butterfield, 1997). However, 'acritarch' denotes a polyphyletic assemblage that includes a variety of different eukaryotes, and it is impossible to meaningfully interpret their significance. There are also a variety of claims for pre-600 Mya metazoan fossils, but these have not achieved general acceptance among paleontologists. Fedonkin et al. (Fendonkin et al., 1994) described microbial mats and some unusual bedding plane markings in rocks of the Appekunny Formation (c. 1400 Mya) in Montana; some of these are probably algal but none are demonstrably metazoan. Seilacher et al. (Seilacher et al., 1998) described branching traces from 1200 (?) Mya rocks from India, but their square cross-section and peculiar branching structure raises doubts about their metazoan affinities. Sun (Sun, 1994) described some narrow, seemingly annulated filaments from Chinese rocks tentatively dated to 700-800 Ma, but the lack of well-preserved structures again makes assignment to metazoa or algae problematic.

The earliest fossil bilaterians may be some remarkable microfossils from the Doushantuo Formation of China that closely resemble the embryos of modern bilaterians, estimated to date from near 570 Mya ago (Xiao et al., 1998; Xiao and Knoll, 1999; Chen et al., 2000), although a diagenetic origin for some of these microfossils cannot yet be ruled out (Xiao et al., 2000). Such unusual phosphatic preservation has been described from elsewhere in the Phanerozoic, but this complex preservational environment (Xiao and Knoll, 1999) appears restricted to a relatively narrow interval of the Neoproterozoic (Cook and Shergold, 1984). While phosphorites may represent an ideal preservational setting for small and delicate organisms, the same opportunity may not occur in older rocks.

Trace fossils provide critical information on the architectural and behavioral complexity of animals that may otherwise be

unrecorded by the fossil record. Diagnostic, unequivocally bilaterian trace fossils are associated only with the latest Neoproterozoic and younger faunas. The typical horizontal laminations of late Neoproterozoic sediments are rapidly replaced after 575 Mya by a growing diversity and complexity of trace fossils, beginning with surface traces 1-5 mm in diameter and followed by penetrating burrows near the Cambrian boundary (Crimes, 1994; Jensen, 1997; MacNaughton and Narbonne, 1999). Reports of faecal strings in trace fossils of this age are intriguing, as confirmation would establish the presence of a complete gut. Associated with this diversification of traces is increased sediment mixing by burrowing, and destruction of microbial mats that helped stabilize the sediment through the latest Neoproterozoic (Droser et al., 1999; Seilacher, 1999; Bottjer et al., 2000). The lack of any evidence of horizontal burrowing in rocks older than about 575 Mya and of vertical burrowing in rocks older than 543 Mya is a strong argument that there existed no animals about 1 cm or longer that were capable of disturbing sedimentary layers before this time. When they do appear, these bilaterian traces indicate the presence of animals that had AP differentiation, but there is no evidence of limbs.

A new assemblage of organisms, known as Ediacaran fauna, appears in the latest Neoproterozoic (c 575-543 Mya), with a few extending into the earliest Cambrian. It is known from a variety of settings and consists largely of enigmatic impressions of soft-bodied organisms. In addition to disks, fronds and superficially bilateral forms of body fossils have been recovered and at least one demonstrable adult bilaterian form, *Kimberella* (Fig. 2). This is interpreted as a benthic animal, most likely of protostome affinity, and possibly a mollusk (Fendonkin and Waggoner, 1997). Numerous specimens of *Kimberella* have been well dated at 555.3 Mya in northern Russia (Martin et al., 2000). Trace fossils of probable Bilateria are found in rocks of the same age. Other elements of the Ediacaran fauna have been assigned to the annelids, echinoderms and arthropods, but none display characters convincingly supporting such phylogenetic assignments. Most Ediacaran fossils lack clearly identifiable appendages, mouth, indications of a digestive system or other characters supporting assignment to the Bilateria. But most can be comfortably interpreted as cnidarian-grade organisms, and indeed there is clear evidence for the prevalence of sponges and cnidarians from both the Doushantuo and Ediacaran assemblages (Gehling and Rigby, 1996; Brasier et al., 1997; Chen et al., 2000; Xiao et al., 2000; Chen et al., 2002).

After 550 Mya there is an accelerating increase in metazoan diversity and complexity, beginning with simple skeletonized tubes and more complex trace fossils, followed at about 530 Mya by the first brachiopods, molluscs and arthropods. The first appearance and diversification of crown group bilaterian clades occurs during the Early Cambrian. The record of body fossils has recently been enriched by the recovery of exceptional fossils from the Early Cambrian Chengjiang deposits in Yunnan, China. These findings supplement the assemblage of bilaterian and other forms known from the Middle Cambrian Burgess Shale of British Columbia, Canada. Cambrian deposits include an array of sponges, arthropods, priapulid and annelid worms and many other groups, including the earliest chordates (Briggs et al., 1994; Chen and Zhou, 1997; Chen et al., 1999; Shu et al., 1999; Shu et al., 2001).



Fig. 2. *Kimberella*, the oldest generally accepted bilaterian fossil from the Ediacaran assemblage. From the Winter Coast of the White Sea, Russia. The adjacent parallel lines are trace fossils associated with *Kimberella*, and are believed to represent infilled feeding scratches through a microbial mat. The presence of these feeding traces suggests that *Kimberella* possessed feeding structure similar to the molluscan radula.

Other recent discoveries include the oldest true crustacean arthropod from the Early Cambrian in England (Siveter et al., 2001). The fossil record reveals a clear pattern of progressive appearance of more complex bilaterian lineages through the Early and Middle Cambrian.

With respect to the firm fossil evidence at present available for late Neoproterozoic metazoans, the only strong conclusions that can be drawn regarding times of divergence are as follows: first, if *Kimberella* is indeed an advanced protostomial animal (Fedonkin and Waggoner, 1997), then the last common PDA must significantly antedate 555 Mya; and second, since crown group cnidarians are already present in Duoshantuo deposits (Chen et al., 2002), the prior cnidarian-bilaterian divergence must have occurred significantly before about 570–580 Mya.

The latest Neoproterozoic is immediately preceded by multiple major continental glaciations that occurred between about 760 and 580 Mya (Kaufman et al., 1997). At least one and possibly more of these events involved glaciation at sea level at near-equatorial latitudes, a highly unusual occurrence. This and other geological evidence led to the proposal of Hoffmann et al. (Hoffmann et al., 1998) that at least some of these glaciations may indicate a complete freezing of the earth's

Fig. 3. Schematic of different possible times of protostome-deuterostome divergence (orange circles), in relation to other events in the late Neoproterozoic. In scenario 1 there is little incongruence between the fossil record and the time of divergence, which occurs following the second or Marinoan glacial interval. In scenario 2, the divergence occurs between the two glaciations, and in scenario 3, before the Sturtian glaciation. Both scenarios 2 and 3 imply a much longer missing interval of post-PDA history. A, Middle Cambrian Burgess Shale fauna; B, Lower Cambrian Chengjiang fauna; C, Diverse Ediacaran fauna; D, Doushantuo phosphorite assemblage (with poor age constraints shown by uncertainty in position). See text for more discussion.

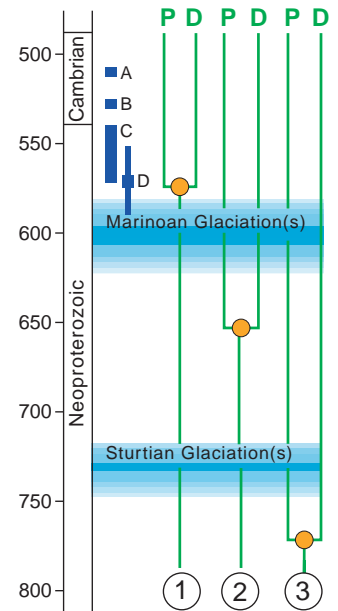

surface for a period of several million years, the so-called 'snowball earth'. Alternative models have now been proposed (e.g. Hyde et al., 2000), and these models all generate sufficient open-water refuges to have allowed the survival of a variety of organisms. Although the extent of glaciation remains uncertain, if the protostome-deuterostome divergence occurred before these world-wide glaciations, they are likely to have imposed a severe ecological constraint on the forms that could have survived. Runnegar (Runnegar, 2000) argued that conditions even within the refugia would have allowed survival only of small, simply constructed, pelagic bilaterian stem group forms [such as proposed for the remote ancestors of the Bilateria by Davidson et al. (Davidson et al., 1995)]. Evolution of adult body plans in the bilaterian stem group would have had to await the more favorable late Neoproterozoic environments.

Three alternate temporal scenarios for the origin of the last common PDA are shown in Fig. 3. In the first, the PDA appears only following the last of the worldwide glaciations. In scenarios 2 and 3 the protostome-deuterostome divergence occurred much earlier, in scenario 3 before the onset of the worldwide glaciations. Survival of any of these lineages would require that there numerous protostome and deuterostome forms must have existed in the evolutionary period between the appearance of the PDA, whenever this occurred, and the appearance of crown group protostomes and deuterostomes in the fossil record. This is because lineages are lost stochastically during evolution, and so the prior stem group bilaterian lineages had to be sufficiently abundant to persist ever since their divergence from the cnidarian lineage (e.g. Raup, 1983). In all the scenarios of Fig. 3 that divergence could have taken place hundreds of millions of years earlier.

So, in summary, although the Neoproterozoic fossil record does not yet explicitly illuminate the PDA and its antecedents, it leaves us with some valuable limits. One constraint is that if the last common PDA predates 555 Mya it is very unlikely to have been constructed in a complex manner, or its remains

would probably have been found. The most reasonable conclusion is that the Neoproterozoic PDA must have been small and was probably constructed simply and delicately. We take up these taphonomic issues again later, armed with a convergent conclusion about the likely nature of the PDA that derives from considerations of bilaterian gene regulatory systems.

MORPHOGENESIS OR DIFFERENTIATION FIRST?

If the canonical body parts of all bilaterians are truly homologous, as suggested by commonalities in their developmental regulatory programs, then the PDA should have had all these same parts. But there is an alternative interpretation for the observations used to support morphogenetic conservation, which may apply to many of the most prominent examples. This can be summarized as follows (Davidson, 2001). Although the heads, hearts, eyes, etc., of insects, vertebrates and other creatures carry out analogous functions, neither their developmental morphogenesis, nor their functional anatomies are actually very similar if considered in any detail. However, in each of the body parts, respectively, the same differentiated cell types are employed across the Bilateria, and it is this fact that underlies their analogous functions: heads all require various types of neurons and their ganglionic associations; hearts necessitate certain kinds of slow contractile cells; eyes require photoreceptor cell types, guts require digestive and secretory cell types; and so forth. Differentiation, or cell-type specification, is due to expression of specific batteries of structural genes that encode the proteins needed to endow that cell type with its functional properties; differentiation is a property of individual cells. Morphogenesis is not: it is the production of multicellular structures, resulting initially from the prior institution of regulatory states that lay out the future pattern of the structure, and then the genetic programs that control cell motility, cell shape and cell division. Sometimes the same differentiation routines are called into play in multiple morphogenetic episodes, such as the use of bone and muscle cell differentiation in most of these diverse morphological parts of our bodies; sometimes particular forms of differentiation are earmarks of given morphogenetic processes, as in all the examples just cited. The regulatory processes that underlie development of specialized differentiated cells are indeed very old, conserved, plesiomorphic features. In contrast, the morphogenetic pattern formation programs by which the body parts develop their form are clade-specific within phyla or classes. The evolution of given body parts probably began with the installation of cell differentiation programs to deploy specific cell types in a certain position in an organism, initially in a very simple morphological context. Later in evolution the transcriptional regulators of these differentiation gene batteries would have been coopted for use in increasingly complex, clade-specific programs of gene regulation that control pattern formation processes. These morphogenetic programs have often continued to be utilized at the same location in the embryo.

In development, morphogenetic regulatory programs for pattern formation precede the institution of cell differentiation programs, but it is likely to have been the reverse in the evolution of body parts. This would allow for the continuing

selective advantage, at each evolutionary stage, afforded by the respective differentiated cell functions. As an example, consider the famous case of *pax6*, a transcriptional regulator utilized in the morphogenesis of eyes in both insects and vertebrates. The common view is that this morphogenetic function of *pax6* is a plesiomorphy descendant from the common PDA. The alternative is that what is actually homologous in the role of the *pax6* gene in the diversely constructed eyes of various bilaterians is only its function in the control of genes encoding visual pigments. All eyes of all kinds require visual pigment genes, and this is the plesiomorphic role of *pax6*; the gene was later coopted for use in the different morphogenetic programs that produce the different structures on which the pigment cells are mounted in different creatures (Sheng et al., 1997; Gehring and Ikeo, 1999; Davidson, 2001). There are a number of other prominent examples that have been interpreted as cases of conservation of morphogenetic regulatory pathways of body part formation from flies to mammals. However, in each case the transcriptional regulator on which the argument is based is also (still) serving to control specific downstream differentiation programs at the terminus of the developmental process, just as is the case of *pax6*. Among the regulatory genes that display apparent conservation of morphogenetic function are *tinman/nkx2.5* in heart, *otx/orthodenticle* in the anterior CNS, *dachshund* in eyes and CNS, *apterous/Lhx* in limbs, *caudal/cad* in posterior gut (see Table 1). The 'bottom-up' view of body part evolution considered here (Davidson, 2001) is one in which the function of controlling differentiation gene batteries was primitive for each body part, while the morphogenetic programs are not conserved, but instead evolved independently and were added in later. A cartoon illustrating this kind of evolutionary process is shown in Fig. 4. The strong prediction is that the architecture of the gene networks controlling the formation of many analogous body parts in unrelated bilaterian clades will turn out to be clade-specific (except for assemblages of genes that always work together whatever the developmental context). However, the (much simpler) architecture of the regulatory apparatus for differentiated cell types will turn out to be conserved across Bilateria. Though yet fragmentary, there is already some convincing evidence on both scores (Davidson, 2001).

Primary differentiated cell types such as muscle cells, neurons of various sorts, photosensitive cells, etc., occur in all bilaterians and it follows that the genome of the PDA must have included the respective differentiation gene batteries and their controllers. Taking *Drosophila* and vertebrates as surrogates for Bilateria (this leaves aside Lophotrochozoa, for which there is as yet only relatively sparse molecular biological evidence), the Bilateria clearly share detailed regulatory control systems for many specific differentiated cell types. Across the Bilateria, for example, cell type-specific gene expression in striated muscle cells is controlled by members of the MyoD family of bHLH transcriptional regulators and by regulators of the Mef2 class (Molkentin et al., 1995) (reviewed by Zhang et al., 1999). Vertebrates and insects share contractile heart cell types that do not use MyoD, but in which certain homeodomain transcriptional regulators of the NK2 family plus the Mef2 factors are required for differentiation (Olson and Srivastava, 1996) (reviewed by Bodmer and Venkatesh, 1998); they use the same transcriptional regulators for the

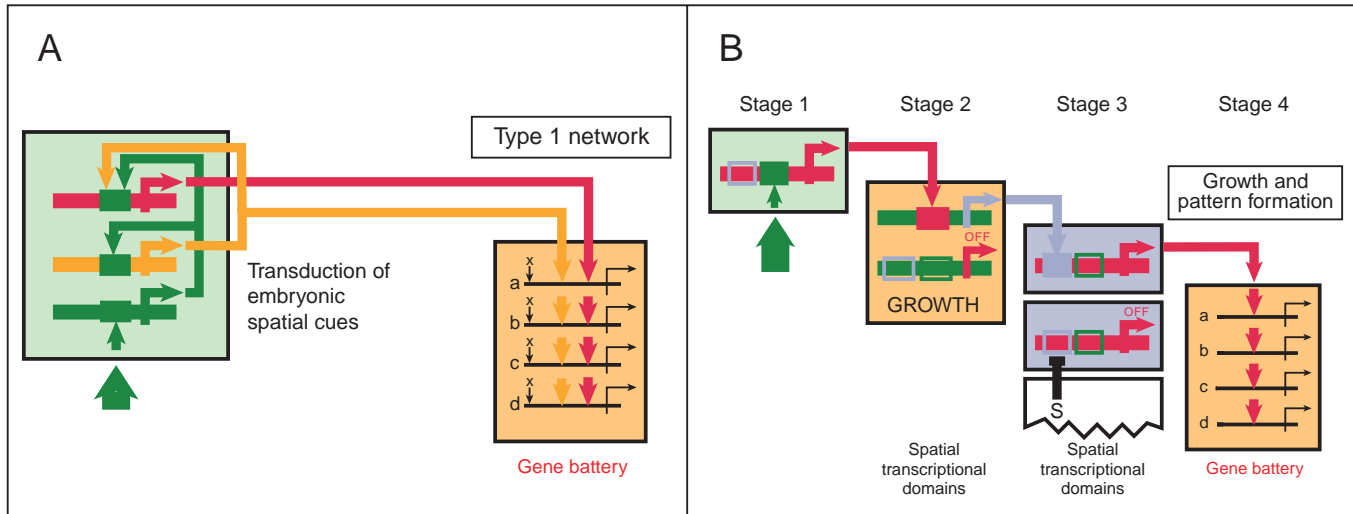

Fig. 4. Evolution of gene regulatory networks during early bilaterian evolution. Colored boxes are transcriptional domains where the state of the domain is dependent upon the presence of the product of the gene of the same color. Stage 1. Initial pattern, similar to that in a Type 1 embryonic system (developmental process in which embryonic lineages proceed directly to expression of differentiation genes) (Davidson, 1991; Davidson, 2001). (A) The genes in the box to left transduce spatial embryonic cues (thick green arrow) and activate an initial gene (green), which in turn activates two additional genes (red and orange) all of which produce transcription factors; the orange gene also cross-regulates the red gene. These transcription factors in turn regulate the gene battery to right. This gene battery encodes proteins used for a differentiated cell type (a-d); each gene has at least two *cis*-regulatory inputs, indicated in orange and red with 'x' denoting other inputs which may vary from gene to gene. (B) Stage 2. Later evolutionary stage: the cell differentiation battery shown in Stage 1 has now been incorporated into a pattern formation system that controls an evolutionarily new morphogenetic process deriving from the state in Stage 1. The additional boxes (Stage 2 and Stage 3) represent new multicellular spatial transcription domains. Only the red gene from Stage 1 is shown in this figure; the red gene is still activated at its initial embryonic address via the green gene as in the ancestor of Stage 1. A new regulatory linkage has appeared, so that the transcriptional activator from the red gene now controls the purple gene, generating the purple transcriptional domain. A growth circuit has also been added. A second *cis*-regulatory module has been added to the red gene, allowing it to be activated by the purple gene product or repressed by a signal (S) from the underlying spatial domain (Stage 3). The result at Stage 4 is to mount the differentiation gene battery on morphological structure of which the patterning and growth are dependent on the yellow and purple transcriptional domains. Redrawn with permission from Fig. 5.7 of Davidson (Davidson, 2001).

differentiation of neuroblasts, motoneurons, pioneer neurons, and glial cells (reviewed by Chan and Jan, 1999; Arendt and Nübler-Jung, 1999); and they share light-sensitive cell types expressing visual pigments of the rhodopsin family (reviewed by Goldsmith, 1990). Vertebrates and insects also share cell types functioning in immune response by activating Toll-class

receptors, mobilizing transcription factors of the *rel/Nfκβ* class, and thereby activating immune effector genes (González-Crespo and Levine, 1994; Lemaître et al., 1996) (reviewed by Hoffman et al., 1999). The argument for the genomic pleisiomorphy in Bilateria of differentiated cell types and the underlying gene batteries could be extended to digestive,

Table 1. Diverse interpretations of some examples of gene use across Bilateria

Gene(s)	Proposed conservation of pathway for:	Alternative proposal: conservation of cell type specification	Refs*
<i>tinman</i> , <i>nkx2.5</i> , <i>mef2</i>	Heart	Control of cardiac type muscle protein genes, other CTS2 [†] cardiac genes	(1-5)
<i>pax6</i> and orthologues	Eye	Control of retinal visual pigment genes, other CTS2 eye genes	(5-9)
<i>orthodenticle</i> and <i>otx</i>	Anterior brain	Differentiation of specific neuronal cell types, acoustic, ocular, olfactory sensory including neurons, neuroblast replication	(10-14)
<i>dachshund</i>	Eyes, central nervous system, many other sites	Control of CTS2 genes in retinal cells (with <i>pax6</i> genes); CTS2 function in ganglionic neurons	(15-17)
<i>apterous</i> and <i>lhx</i> genes	Role in brain, neural tube, olfactory tube	CTS2 function in sensory neurons and in pathfinding activity of interneurons	(16-19)
<i>caudal</i> and <i>cdx</i>	Gut	Control of CTS2 intestinal cell function	(20-24)

*Where possible only reviews are listed in which original references are collected.

[†]CTS, cell type specific.

References: (1) Tanaka et al., 1998; (2) Bodmer and Frasch, 1999; (3) Black and Olson, 1998; (4) Bodmer and Venkatesh, 1998; (5) Davidson, 2001 (Chapter 5); (6) Zucker, 1994; (7) Goldsmith, 1990; (8) Gehring and Ikeo, 1999; (9) Cvekl and Piatigorsky, 1996; (10) Hirth and Reichert, 1999; (11) Acampora et al., 1996; (12) Acampora et al., 1998; (13) Finkelstein and Boncinelli, 1994; (14) Finkelstein et al., 1990; (15) Mardon et al., 1994; (16) Chen et al., 1997; (17) Lundgren et al., 1995; (18) Curtiss and Heilig, 1998; (19) Matsumoto et al., 1996; (20) Epstein et al., 1997; (21) Wu and Lengyel, 1998; (22) James et al., 1994; (23) Marom et al., 1997; (24) Charité et al., 1998.

excretory, respiratory, secretory, detoxification and other pathways as well.

Many of the highly conserved developmental control genes are also present in Cnidaria, as are some of these same differentiated cell types, and thus at least some of these differentiation gene batteries date to the last common ancestor of cnidarians and bilaterians. Galliot (Galliot, 2000) cataloged a set of genes that could be involved in apical cell differentiation in cnidarians, including ANTP-class, Hox/ParaHox, Paired-like and Pax-type PRD homeobox genes and other transcription factor genes including *forkhead* and *brachyury*, as well as WNT pathway and kinase genes. A number of these families are already diversified. Anterior and posterior class Hox genes are present in cnidarians, but not central class *hox* genes, and an *even-skipped* ortholog is linked to these *hox* genes as in bilaterians (Finnerty, 2001). ParaHox genes also appear to predate the cnidarian divergence (Finnerty, 2001). Not so much is known about cnidarian developmental molecular biology, but some examples suggest that cnidarians use transcription factors, which in bilaterians execute pattern formation functions, instead to control cell type-specific gene expression. Two genes that display prominent pattern formation functions in bilaterian development, viz *otx* and *twist*, provide examples. *otx* is expressed in differentiated striated muscle cells in a coral (Müller et al., 1999). In *Hydra*, *otx* expression is correlated with cell mobility (Smith et al., 1999), and *twist* is expressed in the proliferating precursors of these cells (Spring et al., 2000).

An example of the differentiated cell types present in cnidarians is striated muscle cells, which, just as in the equivalent cells in bilaterians, express genes encoding myosin heavy chains and tropomyosin (Schuchert et al., 1993; Gröger et al., 1999; Yanze et al., 1999). Cnidarians also have neurons that display physiological, cytological and histochemical characteristics of bilaterian neurons (reviewed by Mackie, 1990), as well as smooth muscle cells, light sensitive cells, digestive cells and so forth. In general, it may be concluded from the pleisiomorphy of conserved genes and cell differentiation states that genomic regulatory programs for cell differentiation predate any clade-specific bilaterian programs for morphogenetic pattern formation. This is an important point in considering the polarity of body part evolution.

In summary, we conclude that a variety of bilaterian differentiation gene batteries are also shared with cnidarians, while others occur only among bilaterians. But differentiation gene batteries and body parts are not the same thing, and it cannot safely be assumed that the PDA possessed a full range of complex body parts homologous to those of extant Bilateria. These views must also influence recent discussions of homology that reflect the apparent conservation of developmental patterns across widely divergent morphologies (e.g. Abouheif et al., 1997; Abouheif, 1999; Wray and Abouheif, 1998). In order to correctly recognize homology of cell-type specification it is necessary to determine whether orthologous gene batteries are being expressed. But we think the true homologies in some of these cases lie at the level of cell-specification processes, not morphogenesis. Thus cell types within protostome and deuterostome eyes may be homologous, while the morphogenetic processes by which they develop are clade-specific, just as their distant morphologies suggest.

THE GENOMIC 'TOOLKIT' OF THE PDA

From the standpoint of morphogenetic gene networks, differentiation gene batteries are relatively simple regulatory subelements that consist of a highly conserved set of 'linkages' between a few genes encoding transcription factors and the *cis*-regulatory elements of many genes encoding differentiation proteins. Other classes of network subelement are also common to all bilaterians, and hence are part of the shared genomic regulatory heritage from the last common bilaterian ancestor. For example, the signal transduction pathways leading from intercellular ligands and cell surface receptors to transcription factors are orthologous, despite the variety of names, and are conserved across Bilateria. The Wnt/TCF, Dpp or TGF β /MADS, TollR/Rel Factor, Hedgehog/Ci, Nuclear Receptor, Jack/Stat and several other pathways by which cells affect their states of transcriptional activity in response to specific signals from other cells are similar in ecdysozoans and deuterostomes (see Ruvkun and Hobert, 1998; Rubin et al., 2000; International Human Sequencing Consortium, 2001). So also, for example, are the systems of transcriptional co-repression such as those that depend either on Groucho or CtBP, and that allow a variety of exquisitely specific transcriptional repressors to utilize the same machinery for turning off their diverse target genes (Torchia et al., 1998; Zhang and Levine, 1999). Many examples of such conserved genetic devices can be found.

The regulatory 'toolkit' of the Bilateria contains elements that can be used to construct all sorts of body plans, as amply shown by their diverse current usage. Furthermore, we know from those bilaterians that are relatively well studied that many items in the toolkit are used multiple times in the developmental construction of different parts of the same body plan. For instance, in *Drosophila*, spatially defined patterns of transcriptional activity that depend on receptors of Dpp signals emanating from nearby sources are required in specification of dorsal embryonic mesoderm, of midgut, of germaria, of tracheal branches, and of wings, legs and eyes among other body parts (Podos and Ferguson, 1999; Davidson, 2001; Xie and Spradling, 2000); and there are dozens of specific developmental requirements for many of the 42 TGF β genes in mammals (Kingsley, 1994; Hogan, 1996; International Human Genome Sequencing Consortium, 2001). To single out any particular one of these uses and regard it as evidence for a conserved dedication of Dpp/TGF β to a particular morphogenetic process cannot be convincing. To a large degree the same argument applies to transcription factors, most of which play multiple roles during development.

In somewhat more abstract terms, the bilaterian toolkit for morphogenesis consists essentially of devices whose function is to establish spatial domains of transcriptional expression. The programmed and progressive division of morphological space into diverse transcriptional states is the fundamental mechanism by which bilaterians organize the morphogenesis of all of their major body parts and thus their body plans during development. The toolkit includes a number of generally useful spatial patterning devices, beyond its basic repertoire of genes encoding transcription factors and cofactors, and signaling systems. An important class of these devices can be considered to have a 'vectorial' patterning function. That is, they act to set up a series of transcriptional states that extend in a spatial

sequence from one place to another in the developing organism. Receptor-signal transduction systems that respond differentially to diffusible ligands, such as those of the Dpp/TGF β family, according to ligand concentration are vectorial patterning systems [for vertebrates see e.g., Shimizu and Gurdon (Shimizu and Gurdon, 1999); for flies see e.g., Jiang and Struhl (Jiang and Struhl, 1996; Teleman and Cohen, 2000)]. In this general sense the same is true of the chromosomal Hox gene cluster, which produces, as a readout, a nested or sequential spatial series of transcriptional boundaries. In tetrapods this vectorial system is used both for the specification of the AP axis and, in an orthogonal direction, for the specification of the terminal axes of the appendages (Nelson et al., 1996; Davidson, 2001).

Examples of other kinds of morphogenetic function that have been coopted to multiple uses in bilaterian pattern formation processes include the creation of borders or spatial boundaries in which the *engrailed* gene and downstream signaling systems collaborate; and the distinction of distal versus proximal domains by expression of the *distal-less* gene in a variety of (entirely non-homologous) morphological projections from the surface (e.g. Lowe and Wray, 1997). We may think of these spatial control elements (and many others that could be mentioned) as 'chips' in the toolkit, that can be used to build a great variety of developmental patterning apparatuses. The point is that what biological structures they are used to build depends on where they are plugged into the regulatory gene network; that is, on the architecture of the networks in which they are deployed, and not on their own identity. Therefore it is particularly dangerous to assume that such chips have a hard, pan-bilaterian morphogenetic assignment, that has been conserved from an ancestral form.

A DEVELOPMENTAL GENE REGULATORY VIEW OF THE PDA

If the devices in the genetic toolkit for bilaterian morphogenesis are useful for a variety of spatial pattern formation processes, then the actual morphological form of the PDA is to some extent unpredictable. Nevertheless some of its likely properties are implied by the most general class of synapomorphies of all major bilaterian clades, i.e., those characters that are clearly homologous between protostomes and deuterostomes. The most important of these are a two-ended gut with mouth and anus; the major use of mesodermal layers and structures in building the body plan; and a central nervous system. None of these features are present in the cnidarian outgroup. Anterior/posterior organization mediated developmentally by overlapping vectorial patterns of Hox gene expression is a unique bilaterian character. Nor do any of these features, except for the two-ended gut, exist in the primary larvae of any bilaterian that develops by maximal indirect processes (Davidson et al., 1995; Arenas-Mena et al., 1998; Peterson et al., 2000). We may assume that the PDA had all these general features, and that it utilized some of the genetic control apparatus which modern Bilateria display in the development of these basal aspects of their body plans.

The primary example is of course the Hox gene cluster, and its conserved role in developmental formation of transcriptional arrangements along the AP axis. It is interesting

that the morphogenesis of several of the other basal pan-bilaterian features noted here also seems to involve ancient gene clusters. The conservation of these clusters over such immense evolutionary periods indicates that their *cis*-organization has some functional meaning. Genes encoding certain of the Nkx homeodomain regulators are clustered in vertebrates, flies and sea urchins, and these genes appear to be utilized in patterning mesodermal structures as well as for controlling differentiation gene batteries in mesodermal cell types (Jagala et al., 2001) (references in Table 1). The Parahox gene cluster includes the *caudal* gene and other genes encoding a separate class of homeodomain regulators that are expressed at different positions along the developing gut (Brooke et al., 1998; Beck et al., 2000; Kourakis and Martindale, 2000). We can also infer that the PDA utilized the same set of homeodomain regulatory genes in the initial embryonic formulation of its central nervous system as do both insects and vertebrates. The nervous systems of members of both these clades develop initially from bilateral sets of three longitudinal rows of neuroblasts, in the most medial of which *nk2/nk2.2* genes are expressed; in the intermediate row *ind/gsh* genes are expressed; and in the outer row *msh/msx* genes are expressed (Arendt and Nübler-Jung, 1999). Our point is that convincing, and non-controversial, arguments for conservation of genetic regulatory programs for features of the adult body plan that are shared between deuterostomes and protostomes pertain only to general features, such as AP organization, presence of mesodermal structures, two-ended gut, and central nervous system. These shared properties must have been attributes of the last common PDA.

A strong argument has been made that the PDA must have had appendages because *Drosophila* and vertebrates use some of the same patterning devices in the morphogenesis of their limbs (Shubin et al., 1997; Mercader et al., 1999; Rincón-Limas et al., 1999; Carroll et al., 2001). The similarities are indeed detailed and impressive: they include specification of anterior/posterior domains of the limb instituted by expression of a Hedgehog ligand on the posterior side of the future appendage, with the consequential establishment of an organizer that secretes a diffusible signaling factor of the TGF β family (Dpp and BMP2, respectively); the presence of growth control centers in the distal region of the respective appendages; use of the *distal-less* regulatory gene for specification of the distal domain of the future appendage; dorsal-ventral specification of limbs by Lim class transcription factors in *Drosophila* and mice (i.e., the *apterous/lmx1* genes, which, however, are not orthologous); and of other homologous transcription factors to specify proximal regions (*meis1/2* and *pbx1* in vertebrates, and *homothorax* and *extradenticle* in *Drosophila*). But what these observations imply is just that the PDA could divide a field of cells into transcriptional domains which specify (with respect to the body axis) anterior and posterior, and dorsal and ventral regions, and that it also possessed the mechanism for defining concentric central-to-peripheral domains. That is to say, it had the capacity to set up a complete spatial coordinate system in a defined patch of epithelium (as in a modern *Drosophila* imaginal disc). This does not mean that it grew legs or antennae! It could have used such a system to position sensory neurons of various kinds on some portion of its surface, or to array cilia or tentacles, or to attach muscle fibers, or anything else one might imagine (a

remarkable reminder of the multiple uses to which modern appendage patterning systems can be put is their cooption to the role of setting up colored scale patterns in butterfly wings) (Brakefield et al., 1996). Insect and vertebrate legs are constructed entirely differently and it is difficult to imagine a morphogenetic process that would produce a version ancestral to both, i.e., beyond the initial patterning stage.

An argument has also been made for the regulatory homology of insect and vertebrate trunk segments, and various authors have concluded that the PDA must have been segmented (e.g. Holland et al., 1997). But here even the apparent similarities in gene use have not borne up so well to continued examination. As concluded in a perspicacious review of Davis and Patel (Davis and Patel, 1999), there is at present no compelling reason to assume common ancestry in the evolution of the morphogenetic processes leading to the very different segmentation processes in those lophotrochozoans, ecdysozoans and deuterostomes that display metamerism; and in each group, many clades do not.

In conclusion, the PDA possessed the essential bilaterian toolkit for morphogenetic pattern formation, and it deployed many of the differentiation gene batteries that its modern descendants continue to rely on. But the comparative developmental data do not require a morphologically complex PDA. The complexity of the PDA may have been a great advance on its predecessors, but the safest assumption is that its morphology was unprepossessing. It had an AP axis, a two-ended gut, mesodermal layers and a central and peripheral nervous system with sensory cell types. There are no constraints on size or architectural complexity in these arguments, and so this animal may well have been very small as well as very simply constructed, compared to most modern bilaterians.

CONCLUSIONS

What is the likelihood of preserving and recovering a fossilized organism similar to the PDA that we envision? The fossil record provides no constraints on when such an animal could have appeared because it will be hard to find palentological evidence of it.

A small, pelagic PDA might easily have escaped detection in the fossil record. While such forms could potentially be preserved and recovered in association with acritarchs, the latter have a fairly tough coating, compared, for example, to those of delicate swimming marine larvae. Both acritarchs and algal remains are frequently recovered by acid maceration techniques that are likely to destroy fossils with less resistant coatings. The exquisitely preserved Doushantuo embryos demonstrate the atypical conditions required for preservation of material lacking a durable coating. Minute, meiofaunal forms (miniaturized animals that live between the grains of an aquatic sediment) can more easily be discussed from a taphonomic point of view. The modern meiofaunal bilaterians include rotifers, gastrotrichs, and kinorhynchans, which are all millimeter-sized triploblastic animals with moderately resistant coatings. Although they have no Phanerozoic fossil record, the settings searched for microfossils in the Neoproterozoic are ideal for the preservation and discovery of such meiofauna, which tend to have complex morphologies. The magnificent

Orsten deposits from the Cambrian of Sweden demonstrate how well-preserved such minute forms can be (Walossek and Müller, 1990; Walossek and Müller, 1994), and the same is true of microscopic Lower Cambrian arthropod fossils (Siveter et al., 2001). However Conway Morris (Conway Morris, 1998) reconsidered Boaden's (Boaden, 1989) anoxic meiofaunal hypothesis and its more recent derivatives (e.g. Fortey et al., 1997), concluding that modern meiofaunal organisms are sufficiently highly derived to be of limited applicability to understanding the origin of bilateria. The recent intensive studies of the Doushantuo phosphorites demonstrate that much remains to be discovered in the late Neoproterozoic, and further application of thin sections combined with maceration analyses may yet reveal more of the complexity of late Neoproterozoic animal life. But, for what it's worth, no sign of miniaturized, morphologically complex adult bilaterian body plans as intricate as modern meiofaunal animals has yet been seen in these fossil assemblages.

More compelling is the absence of any evidence for macroscopic benthic adult bilaterian forms prior to 555 Mya. In contrast to meiofaunal or pelagic forms, a complex, benthic, vermiform PDA equipped with appendages and segments would almost certainly have been detected, either as a trace or body fossil in Neoproterozoic deposits, as emphasized by many paleontologists (e.g. Conway Morris, 1998; Erwin, 1999; Valentine et al., 1999)

If the PDA indeed existed long before the end of the Neoproterozoic, this would significantly change interpretations of the Cambrian radiation. Since the PDA already possessed the toolkit used by all Cambrian and later bilaterians to develop their adult body plans, why was the appearance of crown group bilaterian clades delayed until after 543 Mya? At least part of the explanation must lie in changes in the physical environment (Erwin, 1992; Erwin, 1999; Valentine et al., 1999; Knoll and Carroll, 1999), and many different environmental and ecological triggers have been advanced. However, although response to climactic or geochemical changes, or increased oxygen levels could indeed facilitate the growth of larger animals, this does not explain the breadth of morphologic innovation (Knoll and Carroll, 1999): innovation in genetic regulatory programs is of course not caused directly by simple ecological change. However, species interactions can fuel diversification of yet more species through ecological feedback; that is, as new forms appear they themselves cause diversification of ecological opportunities and pressures that can be exploited by diverse morphological forms. One thing that is clear from post-Cambrian evolution is that the morphogenetic gene networks used in the Bilateria are evolutionarily very flexible. This is because the bilaterian lineage utilizes developmental pattern formation processes that can easily be used as a platform for further evolutionary variation when conditions permit. The occurrence of explosive evolutionary radiation throughout Phanerozoic time shows that this flexibility has been deployed rapidly when the occasion arises, as for example, following the invasion of land by arthropods and chordates. To build the adult body plan of even the simple PDA that we discuss here would have required the same toolkit that has proved sufficient for the whole diversification of the bilaterians. Whatever the environmental trigger(s), the main point is that since the PDA already owned the toolkit, its descendants possessed what they needed to

take over the world when confronted with the complex opportunities that arose at the end of the Neoproterozoic.

We thank Drs David Bottjer, R. Andrew Cameron, Kevin J. Peterson and Ellen Rothenberg for discussions and review of the manuscript. NASA's National Astrobiology Institute and the Thaw Charitable Trust through the Santa Fe Institute provided funding to D. H. E. and NASA/Ames (NAG 2-1368) Fundamental Space Biology Program to E. H. D.

REFERENCES

- Abouheif, E.** (1999). Establishing homology criteria for regulatory gene networks: prospects and challenges. In *Homolog*, pp. 207-225. Chichester, UK: Wiley.
- Abouheif, E., Akam, M., Dickinson, W. J., Holland, P. W. H., Meyer, A., Patel, N. H., Raff, R. A., Roth, V. L. and Wray, G. A.** (1997). Homology and developmental genes. *Trends Genet.* **13**, 432-433.
- Acampora, D., Mazan, S., Avvantaggiato, V., Barone, P., Tuorto, F., Lallemand, Y., Brûlet, P. and Simeone, A.** (1996). Epilepsy and brain abnormalities in mice lacking the *Otx1* gene. *Nat. Genet.* **14**, 218-222.
- Acampora, D., Avvantaggiato, V., Tuorto, F., Barone, P., Reichert, H., Finkelstein, R. and Simeone, A.** (1998). Murine *Otx1* and *Drosophila* *totd* genes share conserved genetic functions required in invertebrate and vertebrate brain development. *Development* **125**, 1691-1702.
- Adoutte, A., Balavoine, G., Lartillot, N., Lespinet, O., Prud'homme, B. and de Rosa, R.** (2000). The new animal phylogeny: Reliability and implications. *Proc. Natl. Acad. Sci. USA* **97**, 4453-4456.
- Aguinaldo, A. M. A., Turbeville, J. M., Linford, L. S., Rivera, M. C., Garey, J. R., Raff, R. A. and Lake, J. A.** (1997). Evidence for a clade of nematodes, arthropods and other moulting animals. *Nature* **387**, 489-493.
- Arenas-Mena, C., Martinez, P., Cameron, R. A. and Davidson, E. H.** (1998). Expression of the *Hox* gene complex in the indirect development of a sea urchin. *Proc. Natl. Acad. Sci. USA* **95**, 13062-13067.
- Arendt, D. and Nübler-Jung, K.** (1999). Comparison of early nerve cord development in insects and vertebrates. *Development* **126**, 2309-2325.
- Ayala, F. J., Rzhetsky, A. and Ayala, F. J.** (1998). Origin of the metazoan phyla: Molecular clocks confirm paleontological estimates. *Proc. Natl. Acad. Sci. USA* **95**, 606-611.
- Beck, F., Tata, F. and Chawengsaksophak, K.** (2000). Homeobox genes and gut development. *BioEssays* **22**, 431-441.
- Bergstrom, J.** (1989). The origin of animal phyla and the new phylum Procoelomata. *Lethaia* **22**, 259-269.
- Berney, C., Pawlowski, J. and Zaninetti, L.** (2000). Elongation factor 1-Alpha sequences do not support an early divergence of the acoela. *Mol. Biol. Evol.* **17**, 1032-1039.
- Black, B. L. and Olson, E. N.** (1998). Transcriptional control of muscle development by myocyte enhancer factor-2 (MEF2) proteins. *Ann. Rev. Cell Dev. Biol.* **14**, 167-196.
- Boaden, P. J. S.** (1989). Meiofauna and the origins of the metazoa. *Zool. J. Linnean Soc.* **96**, 217-227.
- Bodmer, R. and Frasch, M.** (1999). Genetic determination of heart development. In *Heart Development* (ed. R. P. Harvey and N. Rosenthal), pp. 65-90. San Diego: Academic Press.
- Bodmer, R. and Venkatesh, T. V.** (1998). Heart development in *Drosophila* and vertebrates: Conservation of molecular mechanisms. *Dev. Genet.* **22**, 181-186.
- Bottjer, D. J., Hagadorn, J. W. and Dornbos, S. Q.** (2000). The Cambrian substrate revolution. *GSA Today* **10**, 1-7.
- Brakefield, P. M., Gates, J., Keys, D., Kesbeke, F., Wijngarden, P. J., Monteiro, A., French, V. and Carroll, S. B.** (1996). Development, plasticity and evolution of butterfly eyespot patterns. *Nature* **384**, 236-242.
- Brasier, M. D., Green, O. and Shields, G.** (1997). Ediacarian sponge spicule clusters from Southwestern Mongolia and the origins of the Cambrian fauna. *Geology* **25**, 303-306.
- Briggs, D. E. G., Erwin, D. H. and Collier, F. J.** (1994). *The Fossils of the Burgess Shale*. Washington, DC: The Smithsonian Institution Press.
- Bromham, L., Rambaut, A., Fortey, R., Cooper, A. and Penny, D.** (1998). Testing the Cambrian explosion hypothesis by using a molecular dating technique. *Proc. Natl. Acad. Sci. USA* **95**, 12386-12389.
- Brooke, N. M., Garcia-Fernandez, J. and Holland, P. W. H.** (1998). The ParaHox gene cluster is an evolutionary sister of the Hox gene cluster. *Nature* **392**, 920-922.
- Butterfield, N. J.** (1997). Plankton ecology and the Proterozoic-Phanerozoic transition. *Paleobiology* **23**, 247-262.
- Butterfield, N. J.** (2000). *Bangiomorpha pubescens* n. gen., n. sp.: implications for the evolution of sex, multicellularity, and the Mesoproterozoic/Neoproterozoic radiation of eukaryotes. *Paleobiology* **26**, 386-404.
- Carroll, S. B., Grenier, J. K. and Weatherbee, S. D.** (2001). *From DNA to Diversity*. Malden, MA: Blackwell Science, Inc.
- Chan, Y.-M. and Jan, Y. N.** (1999). Conservation of neurogenic genes and mechanisms. *Curr. Opin. Neurobiol.* **9**, 582-588.
- Charité, J., de Graaff, W., Consten, D., Reijnen, M. J., Korving, J. and Deschamps, J.** (1998). Transducing positional information to the *Hox* genes: critical interaction of *cdx* gene products with position-sensitive regulatory elements. *Development* **125**, 4349-4358.
- Chen, J. Y. and Zhou, G.** (1997). Biology of the Chengjian fauna. In *The Cambrian Explosion and the Fossil Record* (ed. J. Y. Chen, Y.-n. Cheng and H. V. Iken), Bulletin of the National Museum of Natural Science **10**, pp. 11-116, Taiwan, China.
- Chen, J. Y., Huang, D. Y. and Li, C. W.** (1999). An early Cambrian craniate-like chordate. *Nature* **402**, 518-522.
- Chen, J. Y., Oliveri, P., Li, C.-W., Zhou, G. Q., Gao, F., Hagadorn, J. W., Peterson, K. J. and Davidson, E. H.** (2000). Precambrian animal diversity: putative phosphatized embryos from the Doushantuo Formation of China. *Proc. Natl. Acad. Sci. USA* **97**, 4457-4462.
- Chen, J.-Y., Oliveri, P., Gao, F., Dornbos, S. Q., Li, C.-W., Bottjer, D. J. and Davidson, E. H.** (2002). Precambrian animal life: probable developmental and adult cnidarian forms from S.W. China. *Dev. Biol.* (in press).
- Chen, R., Amoui, M., Zhang, Z. and Mardon, G.** (1997). Dachshund and Eyes Absent proteins form a complex and function synergistically to induce ectopic eye development in *Drosophila*. *Cell* **91**, 893-903.
- Clark, R. B.** (1979). Radiation of the Metazoan. In *The Origin of Major Invertebrate Groups* (ed. M. R. House), pp. 55-101. Academic Press: London.
- Coates, M. I. and Cohn, M. J.** (1998). Fins, limbs and tails: outgrowths and axial patterning in vertebrate evolution. *BioEssays* **20**, 371-381.
- Cohen, J. and Massey, B. D.** (1983). Larvae and the origins of major phyla. *Biol. J. Linn. Soc.* **19**, 321-328.
- Collins, A. G. and Valentine, J. W.** (2001). Defining phyla: evolutionary pathways to metazoan body plans. *Evolution and Development* **3**, 432-442.
- Conway Morris, S.** (1998). Early metazoan evolution: reconciling paleontology and molecular biology. *Am. Zool.* **38**, 867-877.
- Cook, P. J. and Shergold, J. H.** (1984). Phosphorus, phosphorites and skeletal evolution at the Precambrian-Cambrian boundary. *Nature* **308**, 231-236.
- Crimes, T. P.** (1994). The period of early evolutionary failure and the dawn of evolutionary success: the record of biotic changes across the Precambrian-Cambrian boundary. In *The Palaeobiology of Trace Fossils* (ed. S. K. Donovan), pp. 105-133. London: J. Wiley & Sons.
- Curtiss, J. and Heilig, J. S.** (1998). DeLIMiting development. *BioEssays* **20**, 58-69.
- Cutler, D. J.** (2000). Estimating divergence times in the presence of an overdispersed molecular clock. *Mol. Biol. Evol.* **17**, 1647-1660.
- Cvekl, A. and Piatigorsky, J.** (1996). Lens development and crystallin gene expression: Many roles for *Pax-6*. *BioEssays* **18**, 621-630.
- Davidson, E. H.** (1991). Spatial mechanisms of gene regulation in metazoan embryos. *Development* **113**, 1-26.
- Davidson, E. H.** (2001). *Genomic Regulatory Systems. Development and Evolution*. San Diego: Academic Press.
- Davidson, E. H., Peterson, K. and Cameron, R. A.** (1995). Origin of the adult bilaterian body plans: Evolution of developmental regulatory mechanisms. *Science* **270**, 1319-1325.
- Davis, G. K. and Patel, N. H.** (1999). The origin and evolution of segmentation. *Trends Genet.* **15**, 15-38.
- De Robertis, E. M. and Sasai, Y.** (1996). A common plan for dorsoventral patterning in bilateria. *Nature* **380**, 37-40.
- de Rosa, R., Grenier, J. K., Andreeva, T., Cook, C. E., Adoutte, A., Akam, M., Carroll, S. B. and Balavoine, G.** (1999). Hox genes in brachiopods and priapulids and protostome evolution. *Nature* **399**, 772-776.
- Droser, M. L., Gehling, J. G. and Jensen, S.** (1999). When the worm turned: concordance of Early Cambrian ichnofabric and trace fossil record in siliciclastic rocks of South Australia. *Geology* **27**, 625-628.

- Epstein, M., Pillemer, G., Yelin, R., Yisraeli, J. K. and Fainsod, A. (1997). Patterning of the embryo along the anterior-posterior axis: the role of the *caudal* genes. *Development* **124**, 3805-3814.
- Erwin, D. H. (1992). A preliminary classification of evolutionary radiation. *Historical Geology* **6**, 133-147.
- Erwin, D. H. (1999). The origin of body plans. *Am. Zool.* **39**, 617-629.
- Fedonkin, M. A. and Waggoner, B. M. (1997). The late Precambrian fossil *Kimberella* is a mollusc-like bilaterian organism. *Nature* **388**, 868.
- Fedonkin, M. A., Yochelson, E. L. and Horodyski, R. J. (1994). Ancient metazoa. *National Geographic Research and Exploration* **10**, 200-223.
- Finkelstein, R. and Boncinelli, E. (1994). From fly head to mammalian forebrain: the story of *otd* and *Otx*. *Trends Genet.* **10**, 310-315.
- Finkelstein, R., Smouse, D., Capaci, T. M., Spradling, A. C. and Perrimon, N. (1990). The *orthodenticle* gene encodes a novel homeodomain protein involved in the development of the *Drosophila* nervous system and ocellar visual structures. *Genes Dev.* **4**, 1516-1527.
- Finnerty, J. R. (2001). Cnidarians reveal intermediate stages in the evolution of *hox* clusters and axial complexity. *Am. Zool.* **41**, 608-620.
- Fortey, R. A., Briggs, D. E. G. and Wills, M. A. (1997). The Cambrian evolutionary 'explosion' recalibrated. *BioEssays* **19**, 429-434.
- Galliot, B. (2000). Conserved and divergent genes in apex and axis development of cnidarians. *Curr. Opin. Genet. Dev.* **10**, 629-637.
- Gehling, J. G. and Rigby, J. K. (1996). Long expected sponges from the Neoproterozoic Ediacara fauna of South Australia. *J. Paleontol.* **70**, 185-195.
- Gehring, W. J. and Ikeo, K. (1999). *Pax6*: Mastering eye morphogenesis and eye evolution. *Trends Genet.* **15**, 371-377.
- Goldsmith, T. H. (1990). Optimization, constraint, and history in the evolution of eyes. *Quart. Rev. Biol.* **65**, 281-322.
- González-Crespo, S. and Levine, M. (1994). Related target enhancers for dorsal and NF- κ B signaling pathways. *Science* **264**, 255-258.
- Gröger, H., Callaerts, P., Gehring, W. J. and Schmid, V. (1999). Gene duplication and recruitment of a specific tropomyosin into striated muscle cells in the jellyfish *Podocoryne carnea*. *J. Exp. Zool.* **285**, 378-386.
- Grotzinger, J. P., Bowring, S. A., Saylor, B. Z. and Kaufman, A. J. (1995). Biostratigraphic and geochronological constraints on early animal evolution. *Science* **270**, 598-604.
- Gu, X. (1998). Early metazoan divergence was about 830 million years ago. *J. Mol. Evol.* **47**, 369-370.
- Hausdorf, B. (2000). Early evolution of the Bilateria. *System. Biol.* **49**, 130-142.
- Hirth, F. and Reichert, H. (1999). Conserved genetic programs in insect and mammalian brain development. *BioEssays* **21**, 677-684.
- Hogan, B. L. M. (1996). Bone morphogenetic proteins: Multifunctional regulators of vertebrate development. *Genes Dev.* **10**, 1580-1594.
- Hoffman, J. A., Kafatos, F. C., Janeway, C. A., Jr and Ezekowitz, R. A. B. (1999). Phylogenetic perspectives in innate immunity. *Science* **284**, 1313-1318.
- Hoffman, P. F., Kaufman, A. J., Halverson, G. P. and Schrag, D. P. (1998). A Neoproterozoic snowball Earth. *Science* **281**, 1342-1346.
- Holland, L. Z., Kene, M., Williams, N. A. and Holland, N. D. (1997). Sequence and embryonic expression of the amphioxus engrailed gene (*AmphiEn*): the metameric pattern of transcription resembles that of its segment-polarity homolog in *Drosophila*. *Development* **124**, 1723-1732.
- Holland, L. Z. (2000). Body-plan evolution in the Bilateria: early antero-posterior patterning and the deuterostome-protostome dichotomy. *Curr. Opin. Genet. Dev.* **10**, 434-442.
- Holland, L. Z. (2002). Heads or tails? Amphioxus and the evolution of anterior-posterior patterning in deuterostomes. *Dev. Biol.* **241**, 209-228.
- Hyde, W. T., Crowley, T. J., Baum, S. K. and Peltier, W. R. (2000). Neoproterozoic 'snowball earth' simulations with a coupled climate/ice-sheet model. *Nature* **405**, 425-429.
- International Human Genome Sequencing Consortium (2001). Initial sequencing and analysis of the human genome *Nature* **409**, 860-921.
- Jagala, K., Bellard, M. and Frasch, M. (2001). A cluster of *Drosophila* homeobox genes involved in mesoderm differentiation programs. *BioEssays* **23**, 125-133.
- Jägersten, G. (1972). *Evolution of the Metazoan Life Cycle*, p. 282. London: Academic Press.
- James, R., Erler, T. and Kazenwadel, J. (1994). Structure of the murine homeobox gene *cdx-2*. *J. Biol. Chem.* **269**, 15229-15237.
- Jensen, S. (1997). Trace fossils from the lower Cambrian Mickwitzia sandstone, south-central Sweden. *Fossils and Strata* **42**, 1-111.
- Jiang, J. and Struhl, G. (1996). Complementary and mutually exclusive activities of decapentaplegic and wingless organize axial patterning during *Drosophila* leg development. *Cell* **86**, 401-409.
- Kaufman, A. J., Knoll, A. H. and Narbonne, G. M. (1997). Isotopes, ice ages, and terminal Proterozoic earth history. *Proc. Natl. Acad. Sci. USA* **94**, 6600-6605.
- Kimmel, C. B. (1996). Was Urbilateria segmented? *Trends Genet.* **12**, 329-331.
- Kingsley, D. M. (1994). The TGF- β superfamily: New members, new receptors, and new genetic tests of function in different organisms. *Genes Dev.* **8**, 133-146.
- Knoll, A. H. (1996). Archean and Proterozoic paleontology. In *Palynology: Principles and applications*, vol. 1 (ed. J. Jansonius and D. C. McGregor), pp. 51-80. American Association of Palynologists Foundation.
- Knoll, A. H. and Carroll, S. B. (1999). Early animal evolution: Emerging views from comparative biology and geology. *Science* **184**, 2129-2137.
- Kourakis, M. J. and Martindale, M. Q. (2000). Combined-method phylogenetic analysis of Hox and ParaHox genes of the metazoa. *J. Exp. Zool.* **288**, 175-191.
- Lemaitre, B., Nicolar, E., Michaut, L., Reichhart, J.-M. and Hoffman, J. A. (1996). The dorsoventral regulatory gene cassette *spätzle/Toll/cactus* controls the potent antifungal response in *Drosophila* adults. *Cell* **86**, 973-983.
- Littlewood, D. T. J., Olson, P. D., Telford, M. J., Herniou, E. A. and Riutort, M. (2001). Elongation factor 1-alpha sequences alone do not assist in resolving the position of the acocela within the metazoa. *Mol. Biol. Evol.* **18**, 437-442.
- Lowe, C. J. and Wray, G. A. (1997). Radical alterations in the roles of homeobox genes during echinoderm evolution. *Nature* **389**, 718-721.
- Lundgren, S. E., Callahan, C. A., Thor, S. and Thomas, J. B. (1995). Control of neuronal pathway selection by the *Drosophila* LIM homeodomain gene *apterous*. *Development* **121**, 1769-1773.
- Mackie, G. O. (1990). The elementary nervous system revisited. *Am. Zool.* **30**, 907-920.
- MacNaughton, R. B. and Narbonne, G. M. (1999). Evolution and ecology of Neoproterozoic-Lower Cambrian trace fossils, NW Canada. *Palaios* **14**, 97-115.
- Mardon, G., Solomon, N. M. and Rubin, G. M. (1994). *dachshund* encodes a nuclear protein required for normal eye and leg development in *Drosophila*. *Development* **120**, 3473-3486.
- Marom, K., Shapira, E. and Fainsod, A. (1997). The chicken *caudal* genes establish an anterior-posterior gradient by partially overlapping temporal and spatial patterns of expression. *Mech. Dev.* **64**, 41-52.
- Martin, M. W., Grazhdankin, D. V., Bowring, S. A., Evans, D. A., Fedonkin, M. A. and Kirschvink, J. L. (2000). Age of Neoproterozoic bilaterian body and trace fossils, White Sea, Russia: implications for metazoan evolution. *Science* **288**, 841-845.
- Matsumoto, K., Tanaka, T., Furuyama, T., Kashihara, Y., Ishii, N., Tohyama, M., Kitanaka, J.-I., Takemura, M., Mori, T. and Wanaka, A. (1996). Differential expression of LIM-homeodomain genes in the embryonic murine brain. *Neurosci. Lett.* **211**, 147-150.
- Mercader, N., Leonardo, E., Azpiazu, N., Serrano, A., Morata, G., Martínez-A., C. and Torres, M. (1999). Conserved regulation of proximodistal limb axis development by *Meis1/Hth*. *Nature* **402**, 425-429.
- Molkentin, J. D., Black, B. L., Martin, J. F. and Olson, E. N. (1995). Cooperative activation of muscle gene expression by MEF2 and myogenic bHLH proteins. *Cell* **83**, 1125-1136.
- Müller, P., Yanze, N., Schmid, V. and Spring, J. (1999). The homeobox gene *Otx* of the jellyfish *Podocoryne carnea*: Role of a head gene in striated muscle and evolution. *Dev. Biol.* **216**, 582-594.
- Nelson, C. E., Morgan, B. A., Burke, A. C., Laufer, E., DiMambro, E., Murtaugh, L. C., Gonzales, E., Tessarollo, L., Parada, L. F. and Tabin, C. (1996). Analysis of *Hox* gene expression in the chick limb bud. *Development* **122**, 1449-1466.
- Nielsen, C. (1985). Animal phylogeny in the light of the trochacea theory. *Biol. J. Linn. Soc.* **25**, 243-299.
- Nielsen, C. and Nørrevang, A. (1985). The trochacea theory: An example of life cycle theory. In *The Origins and Relationships of Lower Invertebrates*. Systematics Association Special Volume (ed. S. Conway Morris, J. D. George, R. Gibson and H. M. Platt), pp. 28-41. Oxford: Clarendon Press.
- Olson, E. N. and Srivastava, D. (1996). Molecular pathways controlling heart development. *Science* **272**, 671-676.
- Peterson, K. J. and Eernisse, D. J. (2001). Animal phylogeny and the ancestry of bilaterians: Inferences from morphology and 18S rDNA gene sequences. *Evol. Dev.* **3**, 170-205.

- Peterson, K. J., Cameron, R. A. and Davidson, E. H. (2000). Bilaterian origins: Significance of new experimental observations. *Dev. Biol.* **219**, 1-17.
- Platt, H. M. (1980). Meiofaunal dynamics and the origin of the metazoa. In *The Evolving Biosphere* (ed. P. L. Forey), pp. 207-216. Cambridge, UK: Cambridge University Press.
- Podos, S. D. and Ferguson, E. L. (1999). Morphogen gradients – New insights from DPP. *Trends Genet.* **15**, 396-402.
- Porter, S. M. and Knoll, A. H. (2000). Testate amoebae in the Neoproterozoic Era: Evidence from vase-shaped microfossils in the Chuar Group, Grand Canyon. *Paleobiology* **26**, 360-385.
- Raup, D. (1983). On the early origins of major biologic groups. *Paleobiology* **9**, 107-115.
- Rieger, R. M., Gazprunar, G. and Schuchert, P. (1991). On the origin of the Bilateria: traditional views and recent alternative concepts. In: *The early evolution of Metazoa and the significance of problematic taxa* (ed. A. M. Simonetta and S. Conway Morris), pp. 107-112. Cambridge: Cambridge University Press.
- Rincón-Limas, D. E., Lu, C.-H., Canal, I., Calleja, M., Rodríguez-Esteban, C. and Izpisua-Belmonte, J. C. (1999). Conservation of the expression and function of apterous orthologs in *Drosophila* and mammals. *Proc. Natl. Acad. Sci. USA* **96**, 2165-2170.
- Rubin, G. M., Yandel, G. M., Wortman, J. R., Gabor Miklos, G. L., Nelson, C. R., Hariharan, I. K., Fortini, M. E., Li, P. W., Apweiler, R., Fleischmann, W. et al. (2000). Comparative genomics of the eukaryotes. *Science* **287**, 2204-2215.
- Ruiz-Trillo, I., Riutort, M., Littlewood, D. T. J., Herniou, E. A. and Baguna, J. (1999). Acoel flatworms: Earliest extant bilaterian metazoans, not members of Platyhelminthes. *Science* **283**, 1919-1823.
- Runnegar, B. (1982). Oxygen requirements, biology and phylogenetic significance of the late Precambrian worm *Dickinsonia*, and the evolution of burrowing habitat. *Alcheringa* **6**, 223-239.
- Ruvkun, G. and Hobert, O. (1998). The taxonomy of developmental control in *Caenorhabditis elegans*. *Science* **282**, 2033-2041.
- Schuchert, P., Reber-Müller, S. and Schmid, V. (1993). Life stage specific expression of a myosin heavy chain in the hydrozoan *Podocoryne carnea*. *Differentiation* **54**, 11-18.
- Scott, M. P. (1994). Intimations of a creature. *Cell* **79**, 1121-1124.
- Seilacher, A. (1999). Biomat-related lifestyles in the Precambrian. *Palaio* **14**, 86-93.
- Seilacher, A., Bose, P. K. and Pfluger, F. (1998). Triploblastic animals more than 1 billion years ago: trace fossil evidence from India. *Science* **282**, 80-83.
- Sheng, G., Thouvenot, E., Schmucker, D., Wilson, D. S. and Desplan, C. (1997). Direct regulation of rhodopsin 1 by Pax-6/eyeless in *Drosophila*: Evidence for a conserved function in photoreceptors. *Genes Dev.* **11**, 1122-1131.
- Shimizu, K. and Gurdon, J. B. (1999). A quantitative analysis of signal transduction from activin receptor to nucleus and its relevance to morphogen gradient interpretation. *Proc. Natl. Acad. Sci. USA* **96**, 6791-6996.
- Shu, D. G., Morris, S. C., Han, J., Chen, L., Zhang, X. L., Zhang, Z. F., Liu, H. Q., Li, Y. and Liu, J. N. (2001). Primitive deuterostomes from the Chengjiang Lagerstätte (Lower Cambrian, China). *Nature* **414**, 419-424.
- Shu, D., Morris, S. C., Zhang, X.-L., Chen, L. and Han, J. (1999). A pipsid-like fossil from the Lower Cambrian of South China. *Nature* **400**, 746-749.
- Shubin, N., Tabin, C. and Carroll, S. (1997). Fossils, genes and the evolution of animal limbs. *Nature* **388**, 639-648.
- Siveter, D. J., Williams, M. and Waloszek, D. (2001). A phosphatocopid crustacean with appendages from the Lower Cambrian. *Science* **293**, 479-481.
- Smith, A. and Peterson, K. J. (2002). Dating the time of origin of major clades: Molecular clocks and the fossil record. *Ann. Rev. Earth Planet. Sci.* (in press).
- Smith, K. M., Gee, L., Blitz, I. L. and Bode, H. R. (1999). *CnOtx*, a member of the *Otx* gene family, has a role in cell movement in *Hydra*. *Dev. Biol.* **212**, 392-404.
- Spring, J., Yanze, N., Middel, A. M., Stierwald, M., Gröger, H. and Schmid, V. (2000). The mesoderm specification factor Twist in the life cycle of jellyfish. *Dev. Biol.* **228**, 363-375.
- Sun, W. G. (1994). Early multicellular fossils. In *Early Life on Earth* (ed. S. Bengtson), pp. 358-369. New York: Columbia University Press.
- Tanaka, M., Kasahara, H., Bartunkova, S., Schinke, M., Komuro, I., Inagaki, H., Lee, Y., Lyons, G. E. and Izumo, S. (1998). Vertebrate homologs of *tinman* and *bagpipe*: Roles of the homeobox genes in cardiovascular development. *Dev. Genet.* **22**, 239-249.
- Teleman, A. A. and Cohen, S. M. (2000). Dpp gradient formation in the *Drosophila* wing imaginal disc. *Cell* **103**, 971-980.
- Torchia, J., Glass, C. and Rosenfeld, M. G. (1998). Co-activators and co-repressors in the integration of transcriptional responses. *Curr. Opin. Cell Biol.* **10**, 373-383.
- Valentine, J. W., Jablonski, D. and Erwin, D. H. (1999). Fossils, molecules and embryos: New perspectives on the Cambrian explosion. *Development* **126**, 851-859.
- Vidal, G. and Moczyłowska-Vidal, M. (1997). Biodiversity, speciation, and extinction trends of Proterozoic and Cambrian phytoplankton. *Paleobiology* **23**, 230-246.
- Walossek, D. and Müller, K. J. (1990). Upper Cambrian stem-lineage Crustacea and their bearing upon the monophyletic origin of Crustacea and the position of Agnostus. *Lethaia* **23**, 409-428.
- Walossek, D. and Müller, K. J. (1994). Pertastomid parasites from the Lower Paleozoic of Sweden. *Trans. R. Soc. Edinburgh* **85**, 1-37.
- Wray, G. A. and Abouheif, E. (1998). When is homology not homology? *Curr. Opin. Genet. Dev.* **8**, 675-680.
- Wray, G. A., Levinton, J. S. and Shapiro, L. H. (1996). Molecular evidence for deep Precambrian divergences among metazoan phyla. *Science* **274**, 568-573.
- Wu, L. H. and Lengyel, J. A. (1998). Role of *caudal* in hindgut specification and gastrulation suggests homology between *Drosophila* aminoproctodeal invagination and vertebrate blastopore. *Development* **125**, 2433-2442.
- Xiao, S. H. and Knoll, A. H. (1999). Fossil preservation in the Neoproterozoic Doushantuo phosphorite Lagerstätte, South China. *Lethaia* **32**, 219-240.
- Xiao, S. H., Yun, Y., Knoll, A. H. and Bartley, J. K. (1998). Three-dimensional preservation of algae and animal embryos in a Neoproterozoic phosphorite. *Nature* **391**, 553-558.
- Xiao, S., Yuan, X. and Knoll, A. H. (2000). Eumetazoan fossils in terminal Proterozoic phosphorites? *Proc. Natl. Acad. Sci. USA* **97**, 13684-13689.
- Xie, T. and Spradling, A. (2000). A niche maintaining germ line stem cells in the *Drosophila* ovary. *Science* **290**, 328-330.
- Yanze, N., Gröger, H., Müller, P. and Schmid, V. (1999). Reversible inactivation of cell-type-specific regulatory and structural genes in migrating isolated striated muscle cells of jellyfish. *Dev. Biol.* **213**, 194-201.
- Zhang, H. and Levine, M. (1999). Groucho and dCtBP mediate separate pathways of transcriptional repression in the *Drosophila* embryo. *Proc. Natl. Acad. Sci. USA* **96**, 535-540.
- Zhang, J.-M., Chen, L., Krause, M., Fire, A. and Paterson, B. M. (1999). Evolutionary conservation of MyoD function and differential utilization of E proteins. *Dev. Biol.* **208**, 465-472.
- Zhou, C., Brasier, M. D. and Xue, Y. (2001). Three-dimensional phosphatic preservation of giant acritarchs from the Terminal Proterozoic Doushantuo Formation in Guizhou and Hubei Provinces, South China. *Palaentology* **44**, 1157-1178.
- Zuker, C. S. (1994). On the evolution of eyes: Would you like it simple or compound? *Science* **265**, 742-743.