



White Paper Blu-ray Disc™ Format

1. A Physical Format Specifications for BD-RE

5th Edition

January, 2018

White Paper Blu-ray Disc™ Format
1A.Physical Format Specifications for BD-RE

Condition of Publication

COPYRIGHT

All rights reserved. This document contains information that is proprietary information of the Blu-ray Disc Association and its members and may not be used, copied or distributed without the written permission of the Blu-ray Disc Association or its License Office. All other use, copying and distribution are prohibited.

TRADEMARK

Blu-ray Disc™, Blu-ray™, Blu-ray 3D™, BD-Live™, BONUSVIEW™, BDXL™, AVCREC™, Ultra HD Blu-ray™ and the logos are trademarks of the Blu-ray Disc Association.

DISCLAIMER

The information contained herein is believed to be accurate as of the date of publication. However, none of the Blu-ray Disc Association, its members, or its License Office will be liable for any damages, including indirect or consequential, from use of the White Paper or reliance on the accuracy of this document.

LICENSING

License is required from the Blu-ray Disc Association for the application of the System Description Blu-ray Disc™ Format in both disc and equipment products.

NOTICE

For any further explanation of the contents of this document, or in case of any perceived inconsistency or ambiguity of interpretation, please consult with:

Blu-ray Disc Association

License Office
4444 Riverside Dr. Suite 103
Burbank, CA 91505 USA

Fax.: +1-818-763-9027
Web Site: <http://www.blu-raydisc.info>
E-mail: agent@blu-raydisc.info

INDEX

INDEX	3
1. Basic Parameters.....	4
2. 0.1-mm-thick Cover.....	7
3. Recording and Playback Technologies	13
3.1. Track Format	13
3.2. Main Blu-ray Disc™ Parameters	13
3.3. Recording and Playback Principles.....	14
3.4. Write strategy	15
3.4.1 N-1 write strategy.....	15
3.4.2 N/2 write strategy.....	16
3.5. Signal Processing Technology PRML	17
3.6. Stress Margin.....	18
3.7. Limit Equalizer	18
4. BDXL™ Technologies	22
4.1. Main Parameters	22
4.2. Disc Structure	23
4.3. Extended Adaptive write strategy.....	26
4.3.1. Extended N-1 write strategy	26
4.3.2. Extended N/2 write strategy	26
4.4. i-MLSE Technology.....	27
5. Modulation Code and Error-Correction Code	31
5.1. Modulation Code	31
5.2. Error-Correction Code	36
6. Address Format Using Groove Wobbles.....	38

1. Basic parameters

The subsequent paragraphs describe the basic philosophy for the physical format of the Blu-ray Disc™ system, the method for determining principal specification values, and the specific technologies used.

1. Basic parameters

The Blu-ray Disc™ system has the following three basic parameters:

- Wavelength (λ) of laser beam: 405 nm
- Objective-lens Numerical Aperture (NA): 0.85
- Cover thickness: 0.1 mm

In developing a next-generation optical disc system beyond the CD and DVD systems, researchers put the highest importance to the recording capacity. In principle, the recording capacity of an optical disc is determined by the spot size, which is proportional to the light-source wavelength λ and inversely proportional to the Numerical Aperture (NA) of objective lens. The capacity, which is in inverse proportion to the square of spot size, can be expressed as follows:

$$\text{Capacity} \propto (\lambda / \text{NA})^{-2}$$

That is, it is possible to increase the recording capacity by decreasing the light-source wavelength and increasing the NA. As the light source of Blu-ray Disc™ we have adopted GaN laser diode (GaN LD) which provides the shortest wavelength of all laser diodes, and have set the laser wavelength at 405 nm, taking into account the resistance of plastic material used in the disc. An objective lens has a theoretical upper limit to its NA. Unless near-field technology is used, the upper NA limit is somewhere little less than 1.0. It would be practically possible to test-manufacture 0.95-NA objective lens by using two-element lens, which is described later. Therefore we decided to use 0.85-NA lens, considering the realistic working distance and production margin. Fig. 1.1 is a graph showing the relation among wavelength, NA, and capacity. The capacity of DVD with 650 nm wavelength and 0.6 NA can be increased 2.5 times by decreasing the wavelength to 405 nm, and can be doubled by increasing the NA to 0.85. In all, the capacity can be increased five times. In this way Blu-ray Disc™ (BD) provides an approximately 25 GB recording capacity, compared to 4.7 GB of DVD.

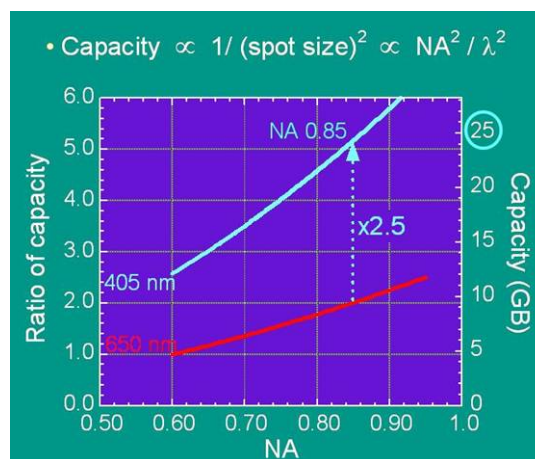

Fig. 1.1 Capacity vs. wavelength and NA

Employing a laser with the shortest possible wavelength and lens with the highest possible NA, as described above, Blu-ray Disc™ has a sufficiently high recording capacity and long life time, and is expected as a promising next-generation optical disc format.

Optical tolerances

Decreased laser wavelength and increased lens NA have yielded higher recording capacity. However, the amounts of optical aberrations increase as the trade-off for the increased capacity. In other words, optical tolerances may decrease.

Major optical aberrations that can occur in an optical disc are defocus caused by a residual error or offset of focusing servo, coma aberration caused by a tilt between the optical axis of optical head and the disc, and spherical aberration caused by an error in cover thickness.

The relation of each optical aberration to wavelength λ , NA and Cover thickness t can be expressed by the following formulas:

$$\begin{aligned} \text{Defocus} &\propto \lambda / \text{NA}^2 \\ \text{Coma aberration} &\propto \lambda / (t \times \text{NA}^3) \\ \text{Spherical aberration} &\propto \lambda / \text{NA}^4 \end{aligned}$$

These are approximate expressions. Actual optical discs tend to have higher optical aberrations, including high-order aberration, relative to NA. Table 1.1 shows example results of calculations.

For the specific wavelength, NA, and cover thickness of each of DVD, DVD Blue (hypothetical) and Blu-ray Disc™, the table gives the tolerances for tilt, Cover-thickness error, and defocus, on the assumption that the amount of aberration is constant.

Table 1.1 Optical tolerances

	Blu-ray_Disc™	DVD Blue	DVD
Wavelength	405 nm	405 nm	650 nm
NA	0.85	0.65	0.60
Cover thickness	0.1 mm	0.6 mm	0.6 mm
Capacity (proportional)	24.3 GB	14.2 GB	4.7 GB
Tilt	0.64 deg.	0.33 deg.	0.70 deg.
Thickness error	± 3.0 μm	± 13 μm	± 30 μm
Ratio of thickness error	± 3.0 μm/100 μm = ± 3.0 %	± 13 μm/600 μm = ± 2.2 %	± 30 μm/600 μm = ± 5.0 %
Defocus	± 0.22 μm	± 0.42 μm	± 0.80 μm

It is clear from this table that Blu-ray Disc™ has almost the same tilt tolerance as for DVD, by decreasing the cover thickness to 0.1 mm to compensate for increased coma aberration resulting from decreased laser wavelength and increased lens NA. If, however, even with a shorter-wavelength laser, the Cover thickness remained 0.6 mm (as in DVD Blue), the tolerance for tilt would decrease to half that of Blu-ray Disc™. In fact, the disc tilt specification for the Blu-ray Disc™ format is 0.35 degree (almost the same level as for DVD). Therefore, Blu-ray Disc™ does not require an optical-head tilt compensation servo like the DVD format.

White Paper Blu-ray Disc™ Format
1A.Physical Format Specifications for BD-RE

1. Basic parameters

The tolerance for cover-thickness error of Blu-ray Disc™ is 1/10 that of DVD. However, since the Cover thickness itself is 1/6 that of DVD, the thickness-error tolerance of Blu-ray Disc™ is larger in ratio than that of DVD Blue. A Cover 100 μm thick can be produced with high precision by sheeting or resin spin-coating, as is described in the following section. Since the Blu-ray Disc™ format sets the standard value of Cover-thickness error in one disc at $\pm 2 \mu\text{m}$, it does not require a high-speed spherical-aberration compensation servo adaptive to rotation period or high-speed access. On the other hand, the standard value for Cover-thickness error between discs is set at $\pm 5 \mu\text{m}$, to effectively expand the disc production margin. In addition, this makes it relatively easy to build a low-speed spherical aberration compensation mechanism in the optical head; low-speed compensation for spherical aberration is necessary when a disc is inserted in a drive. This mechanism is indispensable to Dual-Layer optical discs, in which the layer-to-layer distance is 25 μm. Spherical aberration compensation is indispensable to all Dual-Layer optical discs if they use a shorter-wavelength laser as in Blu-ray Disc™ and DVD Blue.

The defocus tolerance of Blu-ray Disc™ is approximately 1/4 that of DVD Blue. The primary cause of defocus is residual focusing-servo error. Considering the performance of recent actuator of fast double-speed DVD drive, it is relatively easy to set the Reference servo at the focusing servo's crossover frequency of 3.2 kHz. The standard residual-servo-error value of Blu-ray Disc™ is 0.045 μm, which is approximately 1/4 that of DVD. This value is easily achievable in manufacturing discs. The following section specifies measured data.

2. 0.1-mm-thick Cover Layer

As discussed in the previous section, Blu-ray Disc™ (BD) employs a higher-NA objective lens and a shorter-wavelength laser to increase the recording density. To enable this, we have set the Cover thickness to 0.1 mm, taking account of tilt margin, resistance to damage by dust, and disc production process. Production of a thin Cover must meet thickness-related performance requirements, such as median thickness value, and thickness uniformity, as well as optical performance requirements, such as transparency to blue laser beam, and birefringence. In addition, it is also necessary to develop Cover-manufacturing process and structure that take account of the residual focus error and disc tilt resulting from combination with a Substrate. The Cover-related target and standard values for BD are shown as follows;

Thickness variation	$\leq \pm 2 \mu\text{m}$
Birefringence	$\leq 30 \text{ nm}$
Disc tilt	$\leq 0.3 \text{ deg}$
Residual focus error	$\leq 45 \text{ nm}$
Transparent ratio	$> 80 \%$ (Including surface reflection)

During the early development stage of Blu-ray Disc™, two different methods were studied to form a 0.1 mm thick Cover of the disc. One is to transfer the pattern to a 0.1-mm-thick base material and then bond a 1.1-mm-thick Substrate to the base material. The other is to transfer the pattern to a 1.1-mm-thick Substrate by injection molding and then bond a 100 μm -thick Cover to the Substrate. For use in the former method, various pattern-transfer techniques were studied, such as injection molding, and sheet transfer. However, the study revealed that the former method has various problems to overcome: difficulties in transfer itself and in handling the post-processes, such as lamination of pattern-transferred sheet or base material molded into sheet, formation of layers, and bonding. On the other hand, the latter method, in which a Cover is bonded to the 1.1-mm-thick Substrate, has two problems. Firstly, the Recording Layer or Reflective Layer is formed on the opposite side from that of the conventional optical disc. Secondly, since Pits and Grooves are under the Cover, the Groove configuration transferred to the Substrate cannot be maintained, unlike the conventional disc. However, due to optimization of the Groove configuration and development of suitable Recording Layer material, Cover formation by the latter method has become relatively easy. The Blu-ray Disc™ Cover is mostly produced by the latter method at present.

The Cover formation techniques can be divided roughly into two groups. One is to form a 100 μm thick layer on the Substrate using the ultraviolet-curing resin (hereinafter referred to as the "UV resin") employed as the Protective Layer of CD and as Adhesive in DVD. The other is to bond Cover sheet to the Substrate. Fig. 2.1 shows the basic process of each of these techniques: from upper to lower, forming the entire Cover using UV resin (Resin Coating Process), bonding Cover sheet using UV resin, and bonding Cover sheet using pressure sensitive adhesive (PSA). Cover-formation difficulty arises from the thinness of 100 μm and the thickness error requirement of within $\pm 2 \mu\text{m}$. The thickness precision depends on the resin-application precision, manufacturing technique, and the thickness of sheet and Adhesive Layer.

White Paper Blu-ray Disc™ Format
1A.Physical Format Specifications for BD-RE

2. 0.1-mm-thick Cover Layer

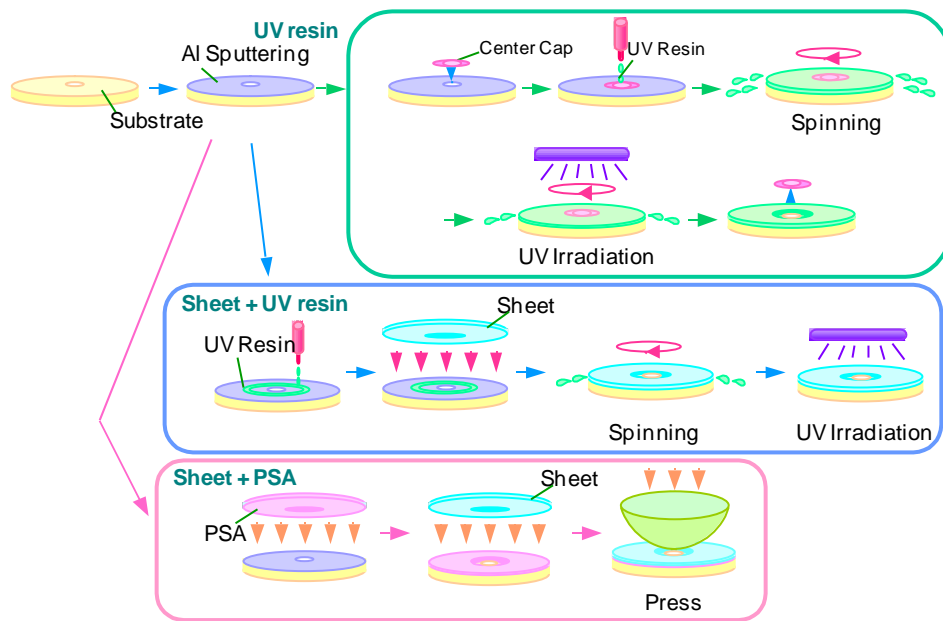

Fig. 2.1 BD Cover-Layer manufacture process

Resin Coating Process has two problems that must be solved: unevenness of resin thickness on the inner and outer peripheries, and resin upheaval on the outer peripheral area due to surface tension. We have overcome these problems by placing a Center Cap over the Center hole, irradiating resin coat with UV while spinning the Substrate, improving the Substrate shape, and so on. Since the BD Cover is thicker by more than one digit than the Protective Layer of CD, the resin used for the BD Cover requires high viscosity, which also makes the process difficult. This difficulty has been overcome by applying the resin in multiple layers (TDK; the Nikkei Electronics, July 17, 2000 issue). Two techniques have been proposed as the method of bonding Cover sheet to the Substrate: one using UV resin; the other using PSA. For both techniques, the performance of sheet itself and the method of forming an Adhesive Layer are of vital importance. When BD was developed in 1996, no materials existed that satisfy the abovementioned stringent performance-related requirements about thickness unevenness, axial runout (particularly at medium to high frequency range of several hundreds of hertz to several kilohertz), and birefringence. Owing to optical-disc inspection equipment introduced, and repetitive review of the process based on disc evaluation result, the present Cover formed by the Sheet bonding method meets the required BD specifications. During the early development stage, the Sheet bonding method using PSA had problems, such as difficulties in embedding fine Groove pattern to achieve high-density recording and in expelling air bubbles, as well as fine axial runout and poor reliability attributed to uneven PSA coat. However, all these problems have been solved as a result of material development. With this method, it is possible to produce BD Cover by applying PSA to a Sheet to form a combination structure, and bonding it to the Substrate after removing the Protective Layer. This process is simple. In addition, the Cover thus produced is precise in thickness. The Sheet bonding method using UV resin is to drip UV resin on the injection-molded Substrate with layers formed thereon, spin the Substrate to make the resin thickness even, and irradiate the Resin Layer with UV to cure it. This process is also simple. The UV resin employed as the Protective Layer of CD and as the

White Paper Blu-ray Disc™ Format

1A.Physical Format Specifications for BD-RE

2. 0.1-mm-thick Cover Layer

Adhesive in DVD can be diverted for use in this method, if only its transparency to UV beam and its resistance to corrosion by the Recording Layer are improved. In addition, since the process resembles the bonding process of DVD, except for Substrate thickness, DVD's bonding techniques can be used for this process. The charts of Fig. 2.2 show the thickness unevenness of Covers formed by the Sheet bonding methods using UV resin and PSA, respectively.

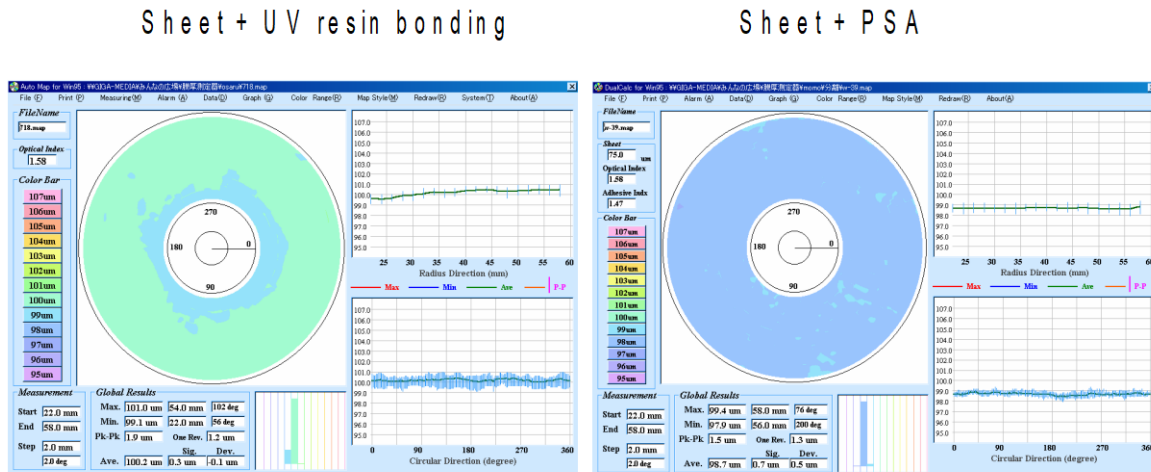

Fig. 2.2 Cover thickness distribution

Birefringence is attributed mostly to the sheet production method, not to UV resin or PSA. Because of high NA, the angle of laser beam converging in the BD Cover is large, resulting in the problem of vertical birefringence, as well as the conventional horizontal birefringence. This causes wavefront aberration to occur in the optical system, resulting in poorer imaging performance and fill-condition, resulting in deterioration of resolution. Conventionally, birefringence on an optical disc is caused by injection-molding orientation, and can be observed concentrically around the disc center. On a Cover sheet, in contrast, birefringence occurs in the Sheet-forming direction and in the direction orthogonal to it. On a rotating disc, therefore, birefringence appears in the form of envelope fluctuation (Fig. 2.3). It is necessary to reduce birefringence, and envelope fluctuation caused by the birefringence.

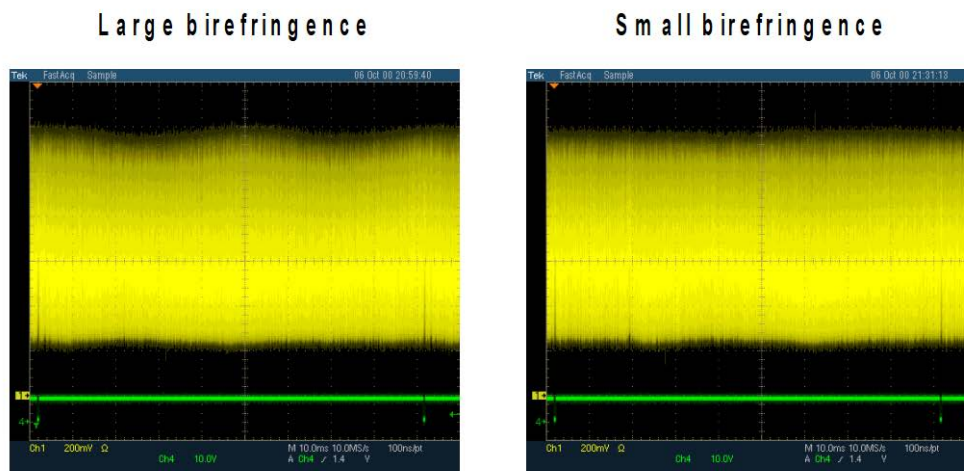

Fig. 2.3 RF envelope variation by birefringence

White Paper Blu-ray Disc™ Format
1A.Physical Format Specifications for BD-RE

2. 0.1-mm-thick Cover Layer

Normally, extrusion method or fusion-casting method is used to produce Cover sheet. Considering the influence of birefringence and of die-line in the extrusion method, the sheet produced by the fusion-casting method is more suitable and meets the requirements.

The tilt margin has been increased as the result of decreasing the Cover thickness. However, since the BD format assumes a drive concept that does not use a tilt servo, further improvement is necessary in the disc production techniques. Disc tilt has two modes: radial tilt in which the disc is warped radially into a cup shape, and tangential tilt in which the disc is warped in the rotating direction. Radial tilt must be decreased. Disc tilt can also be divided into three types according to the cause: tilt caused by the disc manufacturing process, tilt increasing gradually over time as the disc is aged, and tilt generated by a rapid change in the operating environment. As for the tilt caused by the disc manufacturing process, if the conventional UV resin used for the Protective Layer of CD were applied as-is to a thickness of 100 μm , the resultant disc would tilt by approximately 1 degree due to curing contraction. To prevent this, it was necessary to reduce the curing contraction characteristic of the UV resin. Generally, tilt increasing with age is evaluated using the acceleration test. However, since there is no known theory regarding disc tilt, like that of recording material deterioration, each manufacturer uses a different acceleration test method. The most common method is to accelerate aging by soaking a disc in the environment at 80°C and 85 %RH for some 100 hours, then leave the disc at a room temperature for stabilization, and measure the tilt. The disc tilts as the stress in the Substrate, adhesive, Cover sheet and/or Cover resin is released due to accelerated aging. Fig. 2.4 shows the change in tilt as the result of acceleration test. The tilt generated by a rapid change in the operating environment is attributed to the disc asymmetry. Tilt generated by change in temperature involves the influence of linear expansion coefficient and Young's modulus. Tilt generated by change in humidity involves the influence of imbibition. To decrease this mode of tilt, care must be used when selecting Cover sheet and Substrate materials and designing the disc structure. Test data shows that the disc tilt of BD caused by environmental change is smaller than that of a Single-Substrate CD (see Fig. 2.5).

Aging Condition: 80 °C 85%RH96Hours

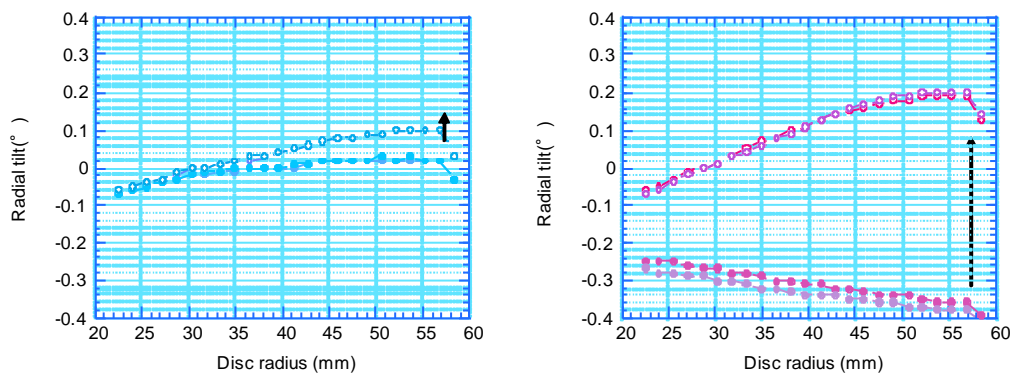
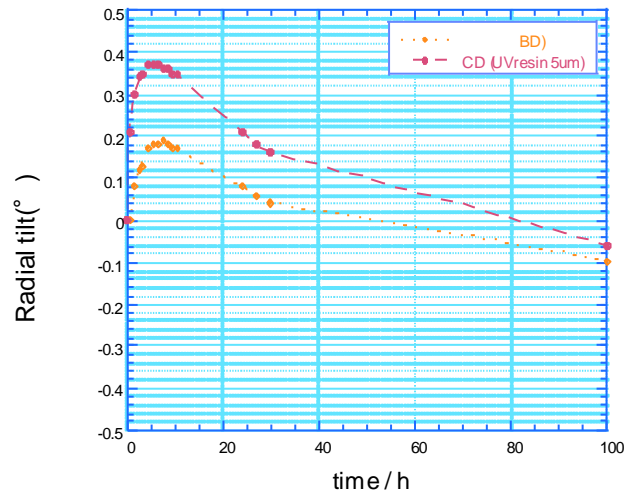

Fig. 2.4 Aging of disc tilt



30 degree C, 90 %RH, 3days→ 23 degree C, 50 %RH (r = 57 mm)

Fig. 2.5 Environmental changes of disc tilt

The third and final problem that must be overcome by an optical disc is residual focus error. While the target focus error for DVD is $0.2\ \mu\text{m}$, that for BD is $0.045\ \mu\text{m}$, which is nearly 1/4 the value for the DVD. Residual focus error is caused by two factors: one relating to the Substrate, and the other relating to the Cover. Especially when the Sheet bonding method is used to produce the Cover, it is important to take heed of the quality of Sheet and Adhesive. Fig. 2.6 shows the residual focus error in each of four optical discs manufactured by different methods. Fig. 2.7 shows the transmittance of Cover Layer.

White Paper Blu-ray Disc™ Format
1A.Physical Format Specifications for BD-RE

2. 0.1-mm-thick Cover Layer

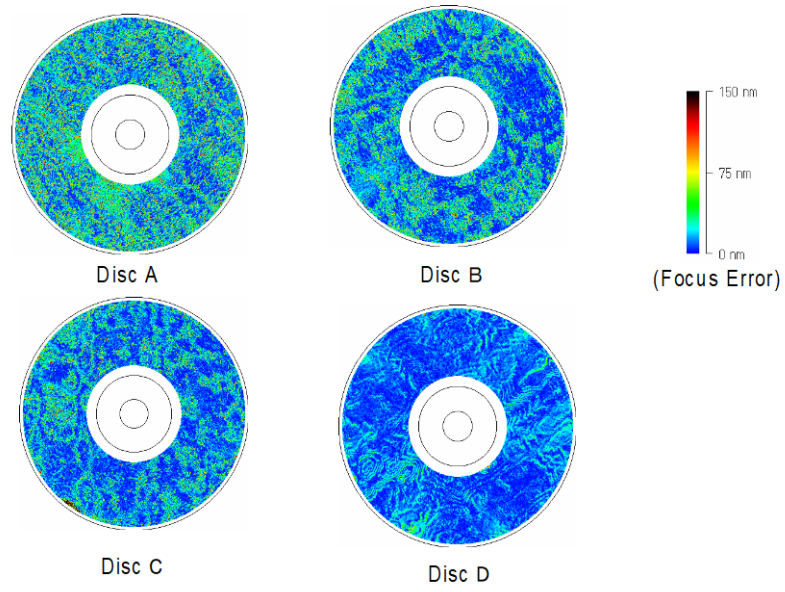

Fig. 2.6 Residual focus error

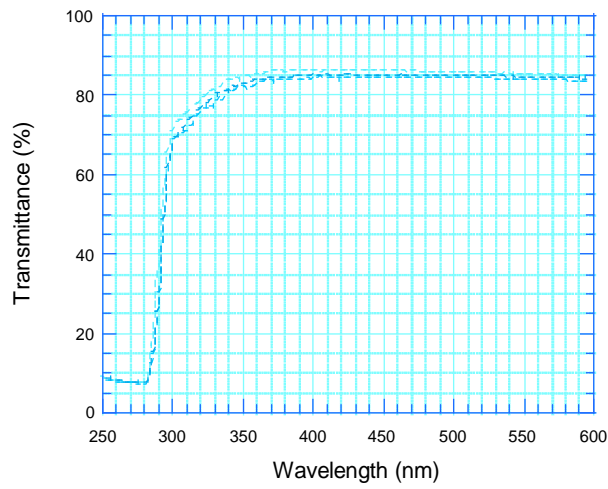

Fig. 2.7 Transmittance of Cover Layer

3. Recording and playback technologies

3.1. Track format

The Track format of Blu-ray Disc™ is Groove-recording, i.e., Recording Data only on Groove Track. For the Groove recording method, Land is sandwiched between adjacent Groove to block heat transfer between the Groove, preventing signal quality deterioration due to the influence of data recording in adjacent Groove Track with a narrow Track Pitch. The Track Pitch between Groove in Blu-ray Disc™ is 0.32 μm.

3.2. Main Blu-ray Disc™ parameters

Table 3.2.1 shows the main parameters of Blu-ray Disc™. As for main optical system parameters, the wavelength of a laser diode is 405 nm, and the NA of objective lens is 0.85. The maximum User Data transfer rate is 36 Mbps for BD-RE version 1.0 and 72 Mbps for version 2.0. The Channel modulation is 17PP.

Table 3.2.1 Main parameters

	Blu-ray Disc™	
Diameter	120 mm	80 mm
Capacity	(SL) 25 GB (DL) 50 GB	(SL) 7.8 GB (DL) 15.6 GB
Wavelength of laser diode	405 nm	
NA of objective lens	0.85	
Cover Layer thickness	0.10 mm(Layer L0,SL),0.075 mm(Layer L1)	
Track format	On-Groove	
Address method	MSK & STW	
Rotation	CLV	
Track Pitch	0.32 μm	
Channel modulation	17PP	
Minimum Mark length	0.149 μm for 25 GB, 50 GB	0.149 μm
Total efficiency	81.7%	
User Data transfer rate	36 Mbps ~ 72 Mbps	

This table shows the main parameters of Blu-ray Disc™.
 A wavelength of a laser diode is 405 nm, and the NA of objective lens is 0.85.
 The Track format is Groove-only recording, and the Track Pitch is 0.32 μm.

Blu-ray Disc™ employs GeSb-based Phase-change materials. For a Single-Layer Blu-ray Disc™, the thickness from the disc surface to the Recording Layer is 100 μm. For a Dual-Layer Blu-ray Disc™, the thickness from the disc surface to the Front Layer (Layer L1) is 75 μm, and that to the Rear Layer (Layer L0) is 100 μm. For the Dual-Layer disc, data recording/playback on the Rear Layer is performed by laser beam transmitted through the Front Layer. Therefore, the Front Layer is required to provide a high and constant optical transmittance of 50 % or more, regardless of its state (whether data-recorded or not).

Blu-ray Disc™ has multiple variations in the recording capacity, to allow user's selection according to use. According to the Specifications Book BD-RE version 1.0, the Single-Layer type has three capacity variations of 23.3, 25 and 27 GB, and the Dual-Layer type 46.6, 50 and 54 GB. The three capacity

3. Recording and playback technologies

variations of each type have been realized by changing the linear recording density, with the Track Pitch constant. The minimum length (2T) of Marks recordable on a disc is 0.160, 0.149 and 0.138 μm, in the order of the recording capacity.

From BD-RE version 2.1, the lowest capacities of 23.3 GB/46.6 GB were excluded from the specifications. One reason was that the disc manufacturing technology progressed and the other reason was to reduce the effort for the test procedure and test discs for a drive.

3.3. Recording and playback principles

The recording/playback principle of Blu-ray Disc™ is described in the following. Fig. 3.3.1 shows the configuration of recording/playback block. The NRZI signal encoded according to the 17PP rule is sent to a Write Pulse Compensator where the signal is modulated to multi-pulse. By adjusting the leading edge of the first pulse and the trailing edge of the cooling pulse of the multi-pulse signal, we can control the accumulation amount in accordance with the Mark length, enabling the Mark edge position precisely. The pulse waveform thus modulated is sent to a laser driver circuit, which modulates the power of laser beam to record Mark/Space data on a Blu-ray Disc™. To play-back recorded data, the reproduced signal through an Equalizer is fed to the Phase-Lock Loop (PLL). The output signal of the Equalizer is also fed to the Analog to Digital converter (A/D) converted to a digital signal at the clock timing of PLL, then passed through a PRML Channel to correct the initial bit error, and output as NRZI signal to the subsequent digital signal processing circuit.

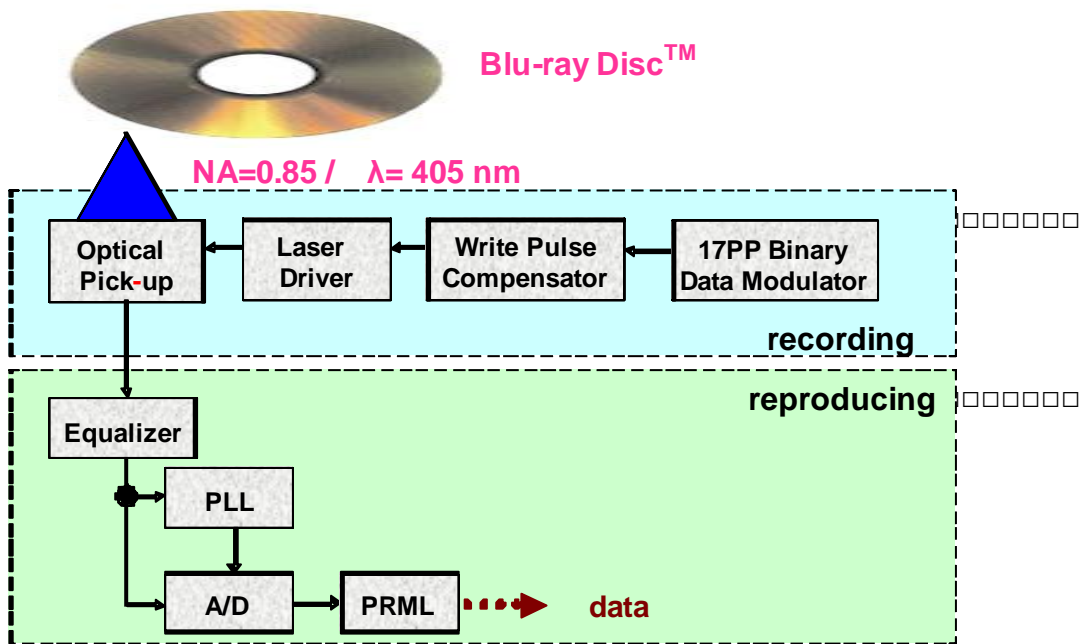

This figure shows a block diagram of Blu-ray Disc™ drive. The 17PP modulated binary data is sent to the Write Pulse Compensator to control the Mark edge position precisely. The output signal of Write Pulse Compensator goes through Laser Driver and Optical Pick-up. The Optical Pick-up has a spherical aberration compensator to focus on the both Layers of the Dual-Layer disc. The reproduced signal was equalized and filtered and passed through PRML decoder to correct the initial bit error.

Fig. 3.3.1 Block diagram of BD drive

The mechanism of forming marks on a Phase-change media is described below. As the Blu-ray Disc™ is irradiated with a train of modulated optical pulses of 2T, 3T and 4T as shown in Fig. 3.3.2, the recording Marks corresponding to the respective code lengths are formed on the disc. Typically,

amorphous Marks are formed in and around high laser power regions. Marks are erased to become Spaces (crystalline) by the erase power irradiation. On the optical disc of Phase-change material, laser beam reads difference in physical characteristic (reflectivity) between the thus formed Marks and Spaces, thereby producing binary data in accordance with to the reflectivity level.

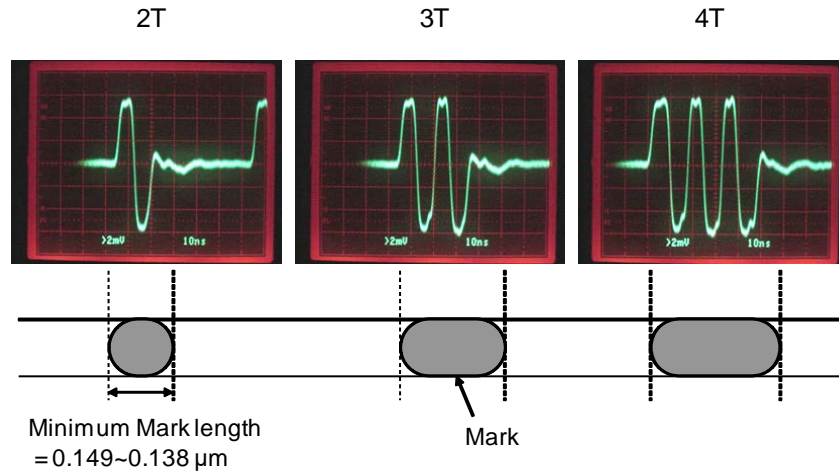

Fig. 3.3.2 Write-pulse waveform

3.4. Write strategy

Two types of write strategies are defined in the Blu-ray Disc™ Rewritable format;

N-1 write strategy which requires one additional write pulse for each Channel-clock cycle beginning with a single pulse for a 2T Mark is applied for discs.

N/2 write strategy which requires additional one write pulse for every 2 consecutive Channel-clock cycles is applied for discs. N/2 write strategy has a single write pulse for a 2T or 3T Mark, 2 write pulses for a 4T and 5T Mark, and so on.

In accordance with the characteristics of each Recording Layer of a disc, a disc manufacturer determines the write strategy parameters and embeds them in the HF Modulated Area and the Wobbled Groove Address of the disc.

3.4.1 N-1 write strategy

Fig. 3.4.1.1 schematically shows the N-1 write strategy for Blu-ray Disc™ Rewritable format, which comprises pulse-modulated recording waveforms with four power levels of P_W , P_{BW} , P_C and P_E . T_{top} denotes the duration of the first write pulse, dT_{top} the start time offset of the first write pulse from its reference position, T_{MP} the duration of all following write pulses except the last pulse, T_{LP} the duration of the last pulse, and dT_E the start time offset of the erase level from its reference position. Fig.3.4.1.1 shows an example of the write-pulse waveform of a 4T Mark. The write pulse offsets (dT_{top} and dT_E), the write pulse duration (T_{top} , T_{MP} and T_{LP}) and the power levels (P_W , P_{BW} , P_C and P_E) are shown. To control Mark edge positions precisely, each parameter (dT_{top} , T_{top} , T_{MP} , T_{LP} or dT_E) is defined in 1/16 of the Channel-clock resolution.

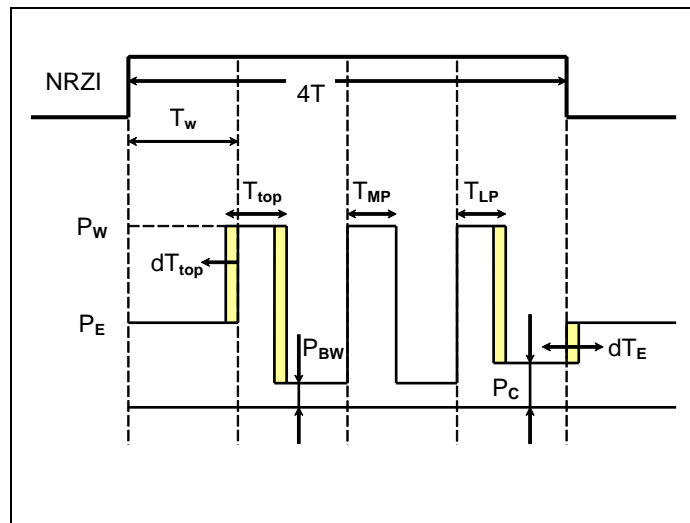

Fig. 3.4.1.1 Write strategy

3.4.2 N/2 write strategy

Fig. 3.4.2.1 schematically shows N/2 write strategy which comprises pulse-modulated recording waveforms with four power levels of P_W , P_{BW} , P_C and P_E . T_{top} denotes the duration of the first pulse, dT_{top} the start time offset of the first pulse from its reference position, T_{MP} the duration of all following write pulses except the last pulse, T_{LP} the duration of the last pulse, and dT_E the start time offset of erase level from its reference position. Fig. 3.4.2.1 shows an example of the write-pulse waveform of 6T Mark. N/2 write strategy has one-half write pulse of Mark length. The write pulse offsets (dT_{top} , dT_{LP} and dT_E), the write pulse duration (T_{top} , T_{MP} and T_{LP}) and the power levels (P_W , P_{BW} , P_C and P_E) are shown. To control Mark edge positions precisely, each parameter (dT_{top} , T_{top} , T_{MP} , T_{LP} or dT_E) is defined in 1/16 of the Channel-clock resolution.

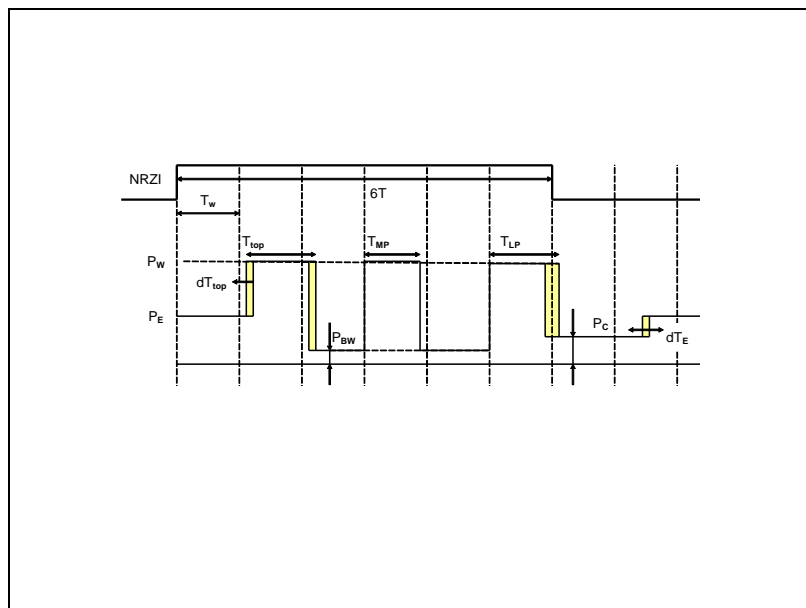
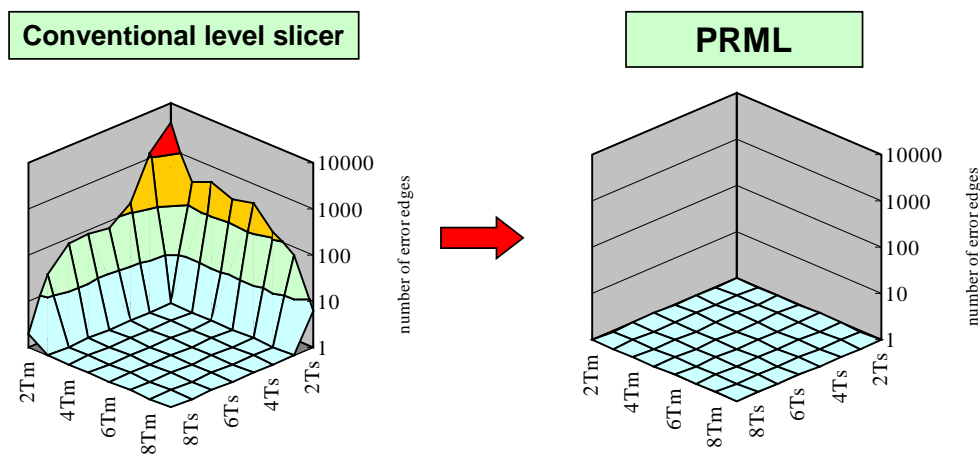

Fig. 3.4.2.1 N/2 write strategy

3.5. Signal processing technology PRML

Since the Blu-ray™ format employs a 17PP modulation, the minimum-length Mark (2T) is shorter than the optical spot size, resulting in high density recording. When recorded signals are played back, therefore, bit error occurs at a high frequency, especially at the edges relating to minimum Marks/Spaces. Fig. 3.5.1 compares the bit-error distribution between the case where the conventional level-slicing method is used for the signal processing (ECC correction is not performed) and the case where the Partial-Response-Maximum-Likelihood (PRML) method is used. The number of bit errors is indicated for each code-length of Mark/Space adjacent to each edge of playback signal processed by binarization.



This figure shows error distributions for 50GB capacity.

Each graph of the figure demonstrates a number of error edges at the combination of Mark and Space length.

With a conventional level slicer, almost all bit errors occurred at the edges of minimum Mark or Space.

But these bit errors could be corrected sufficiently with PRML.

Fig. 3.5.1 Error distributions

In the case where signals are processed by the conventional method, bit errors are concentrated at the edges relating to 2T Marks ($2T_m$) or 2T Spaces ($2T_s$). In the case where the PRML technology is used, the number of bit errors has effectively been reduced. The PRML is a signal processing technology suitable for reproducing a high-density recording data.

Signals recorded on an optical disc deteriorate remarkably in the modulation transfer function (MTF). When such recorded signals are played back, the SNR (Signal-to-Noise Ratio) of minimum code length (2T) in the playback signals decreases, resulting in frequent bit errors at the edges adjacent to 2T. Close study of the error edges adjacent to 2T has revealed that most of such errors occur at the edges adjacent to shorter code length (1T), due to optical Inter-Symbol Interference. The PRML carries out Viterbi decoding in advance based on 17PP modulation rule. Since 1T code is an inhibition code, error correction to a 2T code is easy.

The PRML technology can reproduce high-quality signals from an optical disc with high linear recording density of up to 33.4 GB.

3.6. Stress margin

Fig. 3.6.1 shows the tangential tilt margin characteristic and radial margin characteristic of a Dual-Layer Blu-ray Disc™ on which data is actually recorded using the adaptive Mark compensation and read out with PRML technology. The recording capacity is 50 GB. Both Layers provide satisfactory bit error rate and tangential and radial tilt margin. The tilt margin of Front Layer (Layer L1) is wider than that of Rear Layer (Layer L0), due to thinner Front Layer Substrate and therefore less influence of spherical aberration.

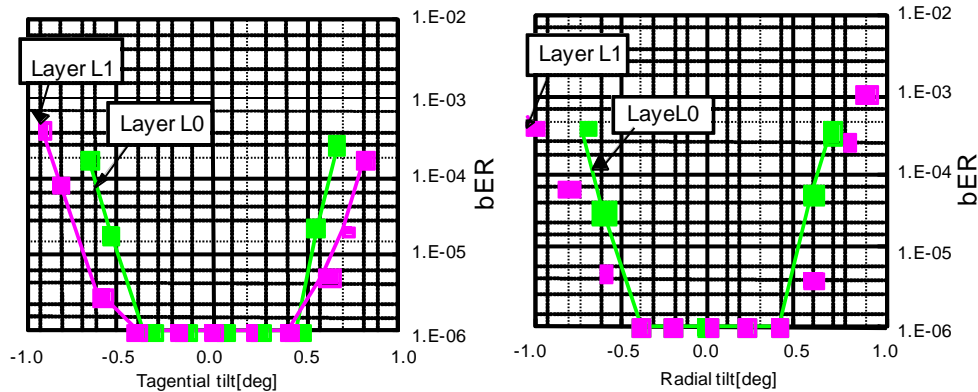

Fig. 3.6.1 Dependences of bER on tilt angle

These figures show the dependences of bER on tilt angles at 50 GB capacity. Left side is tangential tilt margin characteristics and right side is radial tilt margin characteristics. In each graph, green dots are the results on Layer L0 and pink dots are results on Layer L1. With PRML, wide tilt margins were obtained in all conditions. Tangential tilt margins reached more than 0.7 degrees and radial tilt margins attained more than 0.6 degrees. Tilt margins on Layer L1 are wider than those on Layer L0 in both directions. This result shows the influence of coma-aberration on Layer L1 is smaller than that on Layer L0. This is because the cover layer for Layer L1 is thinner than that for Layer L0

3.7. Limit Equalizer

Generally, a playback signal reading system uses a Linear Equalizer to improve the Signal-to-Noise Ratio (SNR) around minimum-length Pits and to suppress the Inter-Symbol Interference. Disc noise exists mainly in a low-frequency region as shown in Fig. 3.7.1. When high frequency around minimum-length Pits is selectively boosted using the Linear Equalizer, the minimum-Pit-length signal-level can be markedly enhanced with a little increase in the total amount of noise. That is, it is possible to improve the SNR by using the Linear Equalizer that boosts high frequency. However, since an excessive boosting of high frequency causes an increase in the Inter-Symbol Interference, the Conventional Linear Equalizer has a limit to the SNR improvement.

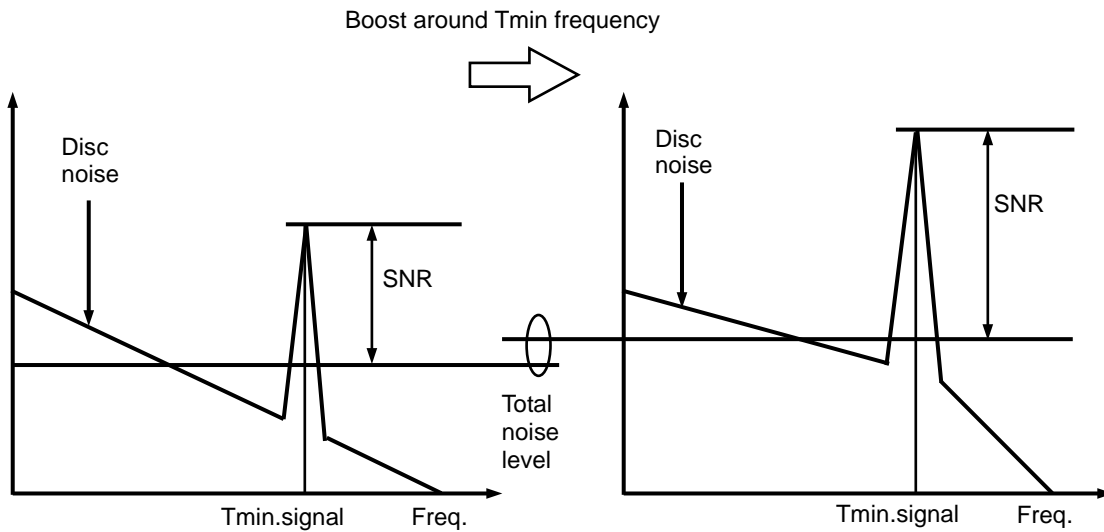

Fig. 3.7.1 SNR improvement of Limit Equalizer

A Limit Equalizer is capable of boosting high frequency without increasing the Inter-Symbol Interference. Fig. 3.7.2 shows the configuration of the Limit Equalizer system for use in 17PP modulation. In this system, a Pre-Equalizer minimizes the Inter-Symbol Interference at the beginning. The Conventional Linear Equalizer is used as the Pre-Equalizer. The Limit Equalizer is located next to the Pre-Equalizer.

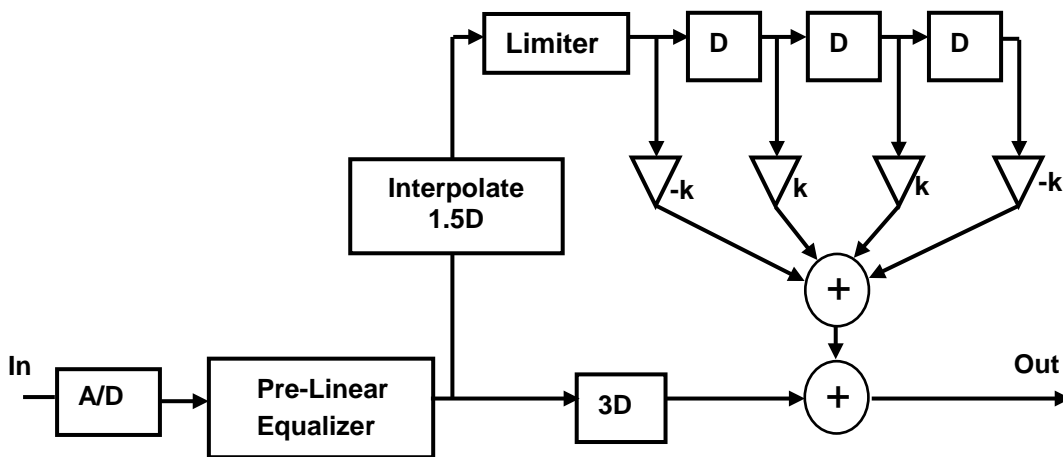

Fig. 3.7.2 Configuration of Limit Equalizer

The Limit Equalizer is almost the same in construction as a Finite-Impulse-Response (FIR) Linear Equalizer, except that the Limiter restricts the amplitude of part of playback signal. The FIR filter acts as a high-frequency-boosting Equalizer, and its gain is determined by coefficient “k.” The gain of FIR filter increases with the value of k. Sample values of playback signal are indicated at the small-circle points in Fig. 3.7.3.

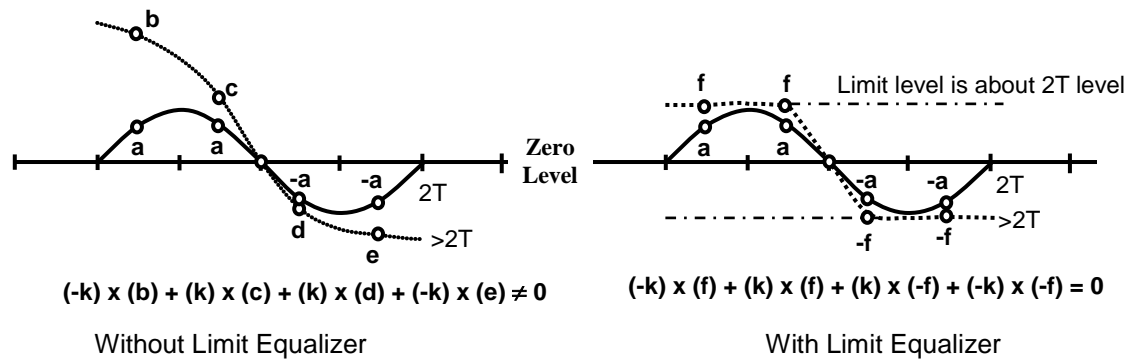

Fig. 3.7.3 Behavior of Linear Equalizer and Limit Equalizer

To understand the operation of the Limit Equalizer, we pay attention to the zero-cross point and the sample values at points close to the zero-cross point. The operation of the Equalizer without a Limiter is as follows. Referring to the left-side chart of Fig. 3.7.3, if playback signal waveform is symmetrical as indicated by the solid line, the data summed up by the Equalizer becomes 0 as expressed by Equation (1), and the zero-cross point does not move.

$$(-k)x(a) + (k)x(a) + (k)x(-a) + (-k)x(-a) = 0 \text{ --- (1)}$$

However, if playback signal waveform is asymmetrical as shown in dot line, the data summed up by the Equalizer does not become 0 as indicated by Equation (2), resulting in the Inter-Symbol Interference.

$$(-k)x(b) + (k)x(c) + (k)x(d) + (-k)x(e) \neq 0 \text{ --- (2)}$$

However, if a Limiter is used to restrict the signal amplitude to around the peak amplitude level of the shortest wavelength signal, the waveform becomes symmetrical as shown by dot line in the right-side chart of Fig. 3.7.3. In that case, the data summed up by the Equalizer is constantly 0, as expressed by Equation (3).

$$(-k)x(f) + (k)x(f) + (k)x(-f) + (-k)x(-f) = 0 \text{ --- (3)}$$

The Limiter does not act on a signal with minimum-length Mark, and the Equalizer amplifies the signal amplitude. For a low-frequency signal with high amplitude, the Limiter restricts the amplitude around the center tap, which is to be added to the sum. The filter gain is effectively decreased. Thus, the Limit Equalizer can boost high frequency without increasing the Inter-Symbol Interference, and we can improve the SNR. Fig. 3.7.4 shows the waveform processed by the Limit Equalizer, in comparison with that processed by the Conventional Linear Equalizer.

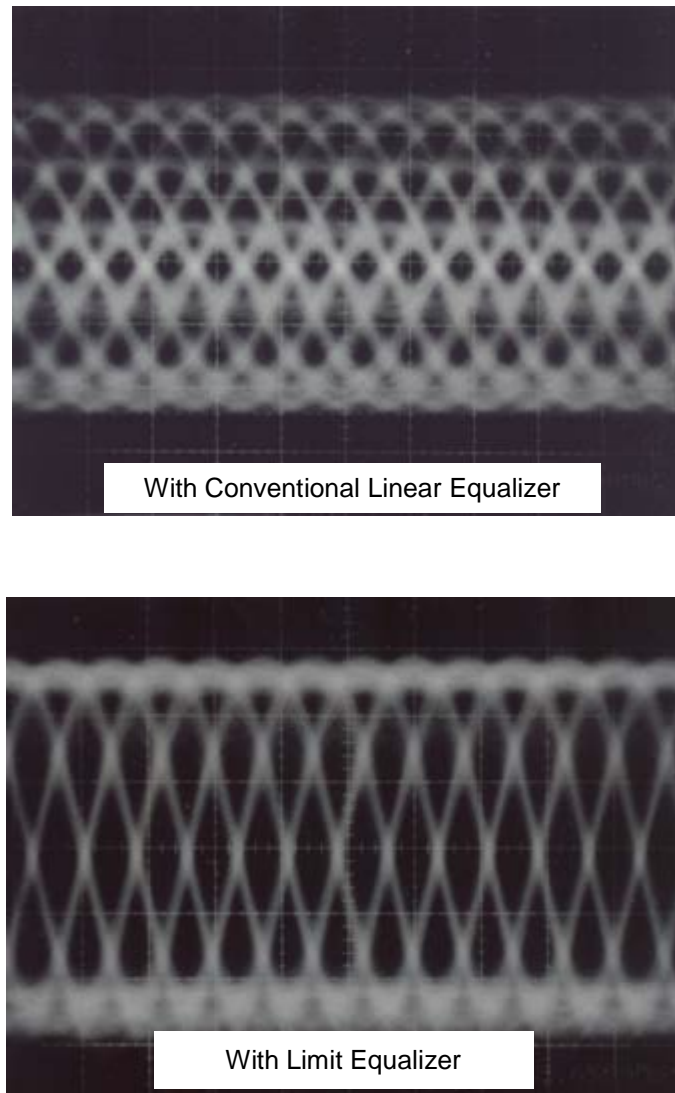

Fig. 3.7.4 Eye diagrams after Linear Equalizer and Limit Equalizer

Since the Blu-ray Disc™ format adopts high-density recording and 17PP modulation, the minimum-Mark length is shorter than for the conventional optical-disc, so that the SNR is low. Viterbi decoding in the disc drive can compensate for the low SNR, to achieve good playback performance. However, since Viterbi-decoding output is the result after 1/0 determination and is poor in sensitivity, it is not suitable for use in evaluating optical discs in general. The jitter of signals processed by a Linear Equalizer is dominated by the component attributed to the noise of disc itself rather than the component attributed to the quality of Recording Marks, making it difficult to determine whether or not the recording state is optimal. In this regard, a Linear Equalizer is not suitable for use in disc evaluation. The Blu-ray Disc™ system employs a Limit Equalizer to improve the SNR and to measure jitter for disc evaluation. With the Limit Equalizer, it is possible to determine the quality of Recorded Marks with high sensitivity.

4. BDXL™ technologies

BDXL™ technologies were developed for the purpose of storing huge capacities of data in order to meet the rapid increase in demand for such devices both in professional and consumer market. In the BDXL™, i.e. BD-RE format version 3.0, only TL with 100 GB capacity was defined reflecting the current Phase-change media manufacturing technology. In this chapter, main parameters, disc structure, write strategy and Extended Adaptive Mark Compensation and i-MLSE are described.

4.1. Main parameters

Main parameters for BD-RE Version 2.2 and Version 3.1 (BDXL™) are listed in Table 4.1.1. The main differences between Version 2.2 and Version 3.1 are in the Cover Layer thickness distribution, capacity per layer, the minimum-Mark length and evaluation index for signal quality. For Version 3.1(BDXL™) only 2X recording of 72 Mbps User Data transfer rate is specified.

4x read option of 144 Mbps User Data transfer rate is added to BD-RE Ver.3.1 (BDXL™) in order to support 4K/8K broadcast recording in November 2017.

Table 4.1.1 Main parameters

	BD-RE Ver.2.2		BD-RE Ver.3.1 (BDXL™)
	SL	DL	TL
Capacity	25 GB	50 GB	100 GB
Wavelength of LD	405 nm		
N.A. of objective lens	0.85		
Cover Layer thickness	100 μm	100 μm (Layer L0)75 μm (Layer L1)	100 μm (Layer L0),75 μm (Layer L1),57 μm (Layer L2)
Capacity per layer	25 GB	25 GB	33.4 GB
Track format	On-Groove		
Address method	MSK & STW		
Rotation	CLV		
Track Pitch	0.32 μm		
Channel modulation	17PP		
Minimum Mark length	149 nm		112 nm
Total efficiency	81.7%		
User Data transfer rate	36-72 Mbps		72 Mbps, 144Mbps read(opt)
Evaluation index for signal quality	Limit Equalizer jitter		i-MLSE using PR(1,2,2,2,1)
Write speed for media	1X,2X		2X, 4x read(opt)

4.2. Disc structure

The disc structure of BD-RE TL (Triple Layer) disc is decided taking account of the following conditions;

- To keep the basic concept of Blu-ray Disc™ format
- Cover Layer should be as thick as possible to be durable against dust, scratch and finger prints.

Fig. 4.2.1 shows an example of disc structure of a TL disc. The distance between Layer L0 and disc surface is 100 μm . It is the same as Single-Layer (SL) and Dual-Layer (DL) discs. The nominal thickness of Cover Layer and each Spacer Layer are shown in this figure. This disc structure was decided paying attention to the two kinds of optical interferences suggested by above constraints.

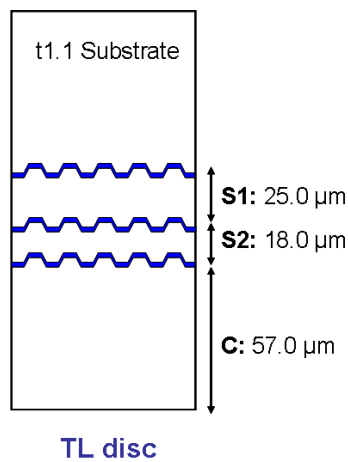

Fig. 4.2.1 Disc structure of TL disc

Two important optical interferences become more and more crucial for determining the disc structure of Multi-Layer (ML) discs as the number of the layers increases.

The first one to be considered is the optical crosstalk from adjacent layers that is shown in Fig. 4.2.2. Fig. 4.2.3 shows dependence of the bit error rate (bER) on the Spacer Layer thickness (S1). The bER becomes worse when the Spacer Layer thickness is less than 10 μm . This phenomenon is caused by the crosstalk between the main signals and signals from adjacent layers. Therefore, the Spacer Layer thickness must be more than 10 μm to avoid deterioration of the readout signal caused by the optical crosstalk from adjacent layers.

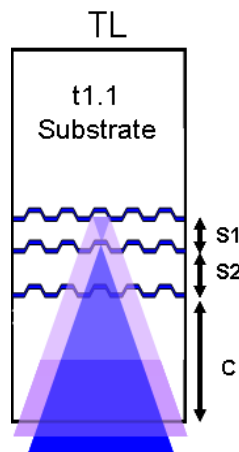

Fig. 4.2.2 Crosstalk from adjacent layers

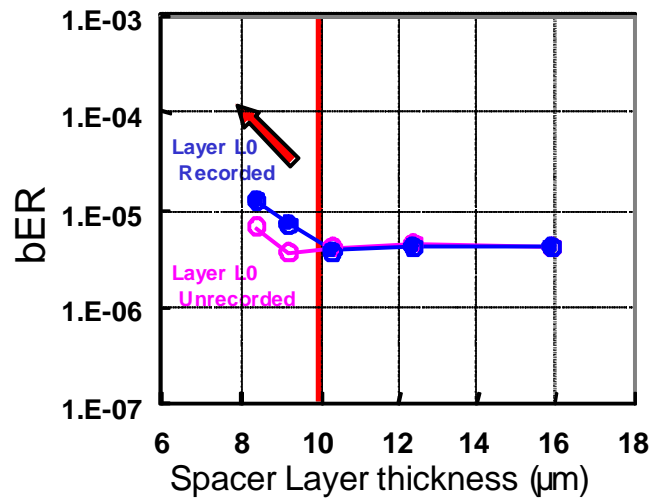

Fig. 4.2.3 Bit error rate dependence of Spacer Layer thickness.

The second one is the optical Inter-Layer Interference. Fig. 4.2.4 shows influence of optical path difference between the main signal light and uninvited three-times-reflected signal light. Red dotted line shows the three-times-reflected light. This light is very weak. But once it focuses on the photodetector, it interferes with the main signal. Fig. 4.2.5 shows the influence of the difference in thickness between Spacer Layer (S1) and Spacer Layer (S2) on the readout signal. The disturbances are observed in the readout signal when the difference in the thickness of S1 and S2 becomes less than 1 µm. This optical Inter-Layer Interference occurs in any combination of thickness differences among Cover Layer and Spacer Layers.

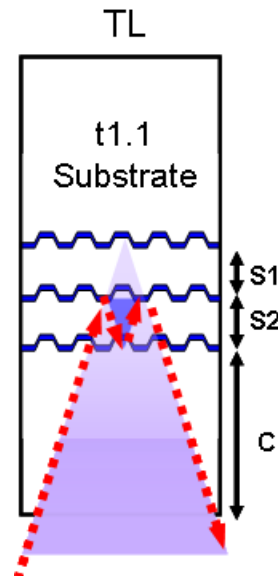

Fig. 4.2.4 Optical Inter-Layer Interference

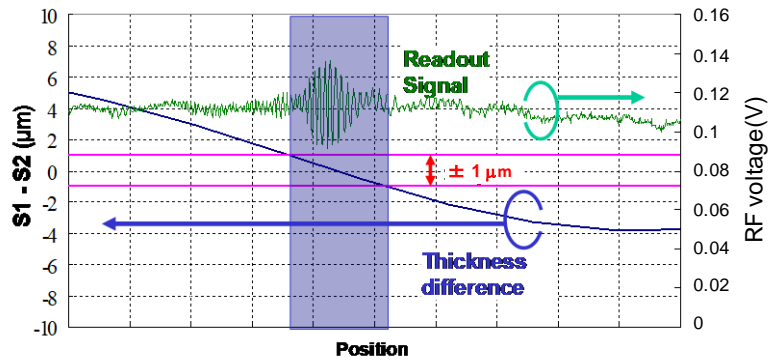

Fig. 4.2.5 Influence of optical path difference between the signal light and three-times-reflected signal light on readout signal.

Judging from above experimental results and presupposition of keeping basic concept of Blu-ray Disc™ format, disc structure of a TL disc is determined as follows;

- Total thickness of Total Cover Layer and Spacer Layers shall be 100 μm
- Thickness of Spacer Layers shall be more than 10 μm
- Differences in thickness among Spacer Layers and Cover Layer shall be more than 1 μm
- Thickness of Cover Layer should be as thick as possible so that above conditions are fulfilled.

The example of disc structure shown in Fig. 4.2.1 fulfills above conditions.

4.3. Extended Adaptive write strategy

Two types of write strategies are defined in the Blu-ray Disc™ Rewritable format (BDXL™);

Extended N-1 write strategy and Extended N/2 write strategy are applied for the discs. These write strategies are based on N-1 write strategy and N/2 write strategy respectively. As the recording density of BDXL™ is higher, a Mark/Space variation matrix is extended to 4 Marks x 4 Spaces to cancel Inter-Symbol Interference between Recording Marks. And Space adaptive parameters are expanded from only preceding Space to preceding and succeeding Spaces.

In accordance with the characteristics of each Recording Layer of a disc, a disc manufacturer determines the above write pulse parameters and embeds them in the HF Modulated Area and the Wobbled Groove Address of the disc.

4.3.1. Extended N-1 write strategy

Fig. 4.3.1.1 schematically shows Extended N-1 write strategy which comprises pulse-modulated recording waveforms with four power levels of P_W , P_{BW} , P_C and P_E . T_{top} denotes the duration of the first pulse, dT_{top} the start time offset of the first pulse from its reference position, T_{MP} the duration of all following pulses except the last pulse, T_{LP} the duration of the last pulse, dT_{LP} the start time offset of the last pulse, and dT_E the start time offset of the erase level from its reference position. dT_{LP} is added to control a trailing Mark edge position more precisely. The other parameters are the same as conventional N-1 write strategy. Fig. 4.3.1.1 shows an example of the Write-pulse waveform of a 4T Mark. The write pulse offsets (dT_{top} , dT_{LP} and dT_E), the write pulse duration (T_{top} , T_{MP} and T_{LP}) and the power levels (P_W , P_{BW} , P_C and P_E) are shown. To control Mark edge positions precisely, each parameter (dT_{top} , T_{top} , T_{MP} , T_{LP} or dT_E) is defined in 1/32 of the Channel-clock resolution.

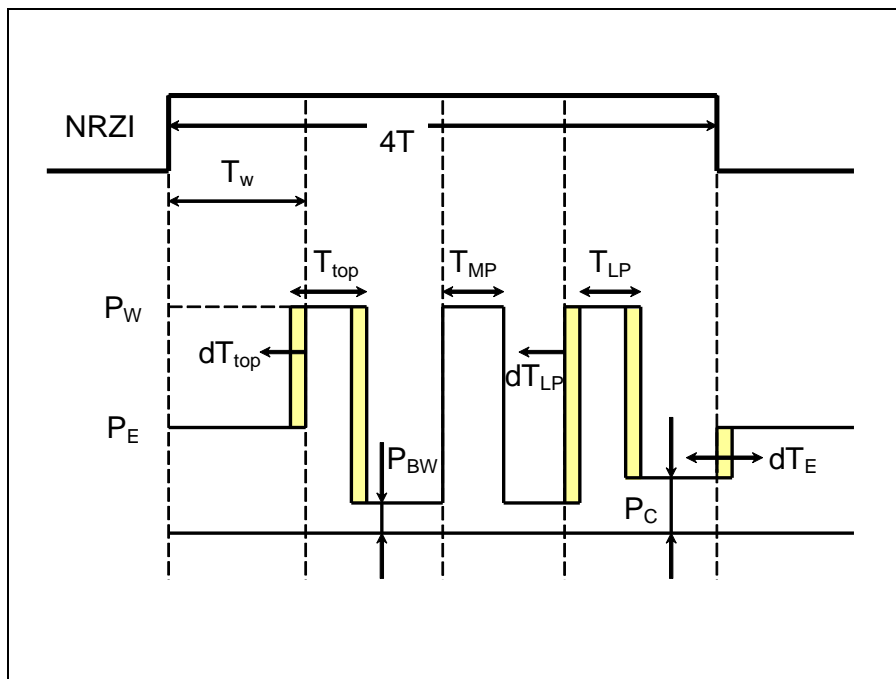

Fig. 4.3.1.1 Extended N-1 write strategy

4.3.2. Extended N/2 write strategy

Fig. 4.3.2.1 schematically shows Extended N/2 write strategy which comprises pulse-modulated recording waveforms with four power levels of P_W , P_{BW} , P_C and P_E . All parameters are the same as conventional N/2 write strategy. T_{top} denotes the duration of the first pulse, dT_{top} the start time offset of the first pulse from its reference position, T_{MP} the duration of all following pulses except the last pulse,

T_{LP} the duration of the last pulse, dT_{LP} the start time offset of the last pulse and dT_E the start time offset of erase level from its reference position. Fig. 4.3.2.1 shows an example of the Write-pulse waveform of 6T Mark. N/2 write strategy has one-half write pulse of Mark length. The write pulse offsets (dT_{top} , dT_{LP} and dT_E), the write pulse durations (T_{top} , T_{MP} and T_{LP}) and the power levels (P_W , P_{BW} , P_C and P_E) are shown. To control Mark edge positions precisely, each parameter (dT_{top} , T_{top} , T_{MP} , dT_{LP} , T_{LP} or dT_E) is defined in 1/32 of the Channel-clock resolution.

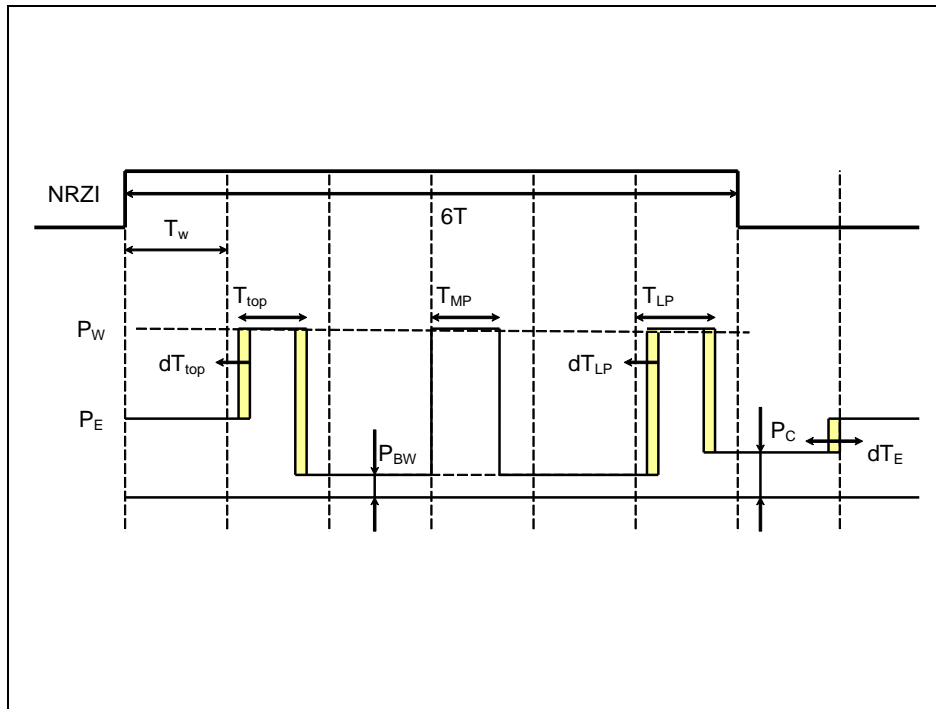
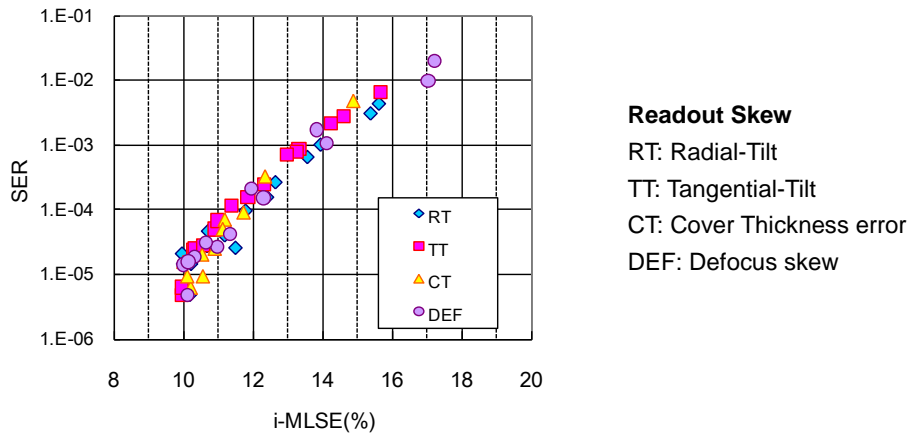

Fig. 4.3.2.1 Extended N/2 write strategy

4.4. i-MLSE Technology

Introduction

In BDXL™ formats the capacity per layer is raised up to 33.4 GB or 32.0 GB only by increasing the linear density. As a result, in BDXL™, the Inter-Symbol Interference (ISI) of the readout signal becomes much stronger compared to the prior format that allows just 25 GB per layer. Therefore the readout signal processing needs to be improved. Also, the prior signal quality evaluation method using the Limit Equalizer technology has turned out to be no longer applicable. Integrated-Maximum Likelihood Sequence Error Estimation (i-MLSE), which is an alternative signal quality evaluation method for BDXL™, was newly developed and retains the stability and the precision in such a severe ISI condition of BDXL™. The evaluation method of i-MLSE stands on the detection principle of the Viterbi-Algorithm (VA) in the Partial-Response-Maximum-Likelihood (PRML) readout signal processing. Additionally, some contrivances can be incorporated to achieve the better correlation with the Symbol Error Rate (SER). For example, the tendency of error occurrences with the PR(1,2,2,2,1)ML readout in the BDXL™ is considered. Another feature of i-MLSE is that the mathematical expression is the same as that of Time-Interval-Jitter (TI-Jitter or Jitter, simply), which is the prior signal quality evaluation method. Consequently, the behavior of i-MLSE is very similar to that of the TI-Jitter. This helps people who evaluate the BDXL™ discs or systems for the first time to comprehend the meaning of measured values obtained through i-MLSE because the TI-Jitter has been used so long since the era of CDs and is very familiar to them.



This figure shows measurement results of i-MLSE and SER for BDXL™ discs under various kinds of read-out conditions. All plots including different kinds of read-out condition are approximately on the same curve. In other words, well-matched correlation performance of i-MLSE is demonstrated here.

Fig. 4.4.1: i-MLSE and SER correlation

Basic theory of i-MLSE

i-MLSE is calculated from Sequenced-Amplitude-Margin (SAM) that indicates the reliability of VA. SAM is an instantaneous value that is defined as the path-metric differences between the Maximum-Likelihood-path (ML-path; decoded result in VA) and the Second-Likelihood-path (2nd-path) as shown in the left side figure of Fig. 4.4.2. In VA the path that has the smallest path-metric survives as the more-likelihood path at every state to which several branches are inflowing, as shown in the right side trellis diagram of Fig. 4.4.2. Therefore, the detection reliability of the VA can be quantified by how smaller the path-metric of the ML-path compared to the rivalry paths' path-metric, in other words, how large the SAM value is.

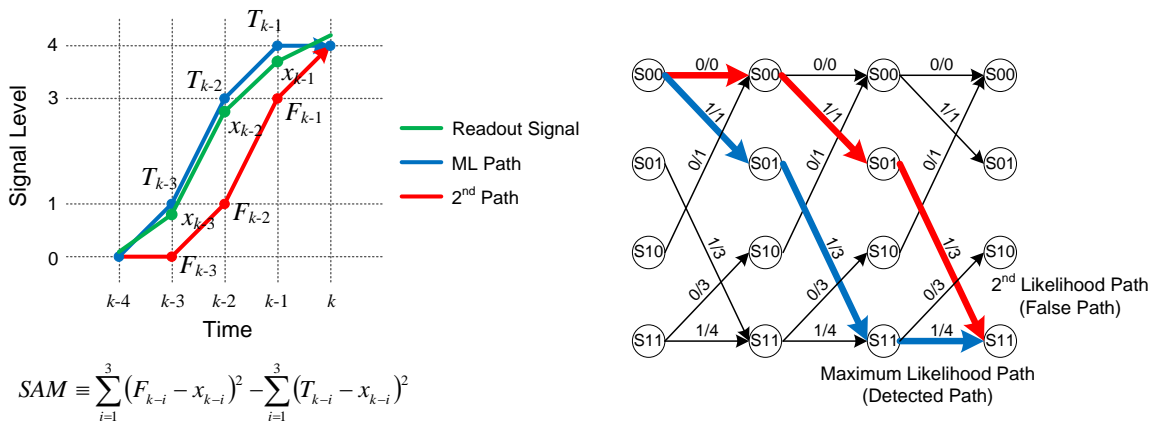

Left figure shows how to calculate the SAM value and right figure shows the trellis diagram of VA. Although PR(1,2,2,2,1)ML with d=1 run-length limited (i.e., ten states) is employed in the BDXL™ specification, simpler PR(1,2,1)ML with d=1 run-length limited (i.e., four states) is assumed in these figures for ease of understanding of the concept of SAM.

Fig. 4.4.2: Calculation of SAM value

Generally, readout waveforms are distributed around ideal waveforms (i.e., ML-paths). In these cases, the distribution of SAM values is revealed to be approximately a normal distribution which means SAM value is almost equal to the square Euclidean distance between ML-path and 2nd-path. By fitting the SAM distribution to the normal distribution we can calculate the error rate from the probability of appearance of the region in which SAM<0. If the SAM distribution can be approximated as a single normal distribution from the viewpoint of prediction of error occurrences, the evaluated value of i-MLSE can be defined in completely the same manner as in the prior TI-Jitter. But actually, there are several error-dominant patterns which have different Euclidean distances and different variances (i.e. plural different normal distributions) in BDXL™. Therefore, to quantify the signal quality by a single value, it is required to evaluate contributions of the estimated errors from plural distributions with different variance and different mean value. In i-MLSE three groups of error-patterns are evaluated as error-dominant patterns as shown in the Table 4.4.1.

Table 4.4.1 Evaluating error-patterns of i-MLSE

Group Name	Group 14	Group 12A	Group 12B
Error Mode	One bit shift	Single 2T shift	Consecutive 2T shift
Euclidean Distance (d _k)	$\sqrt{14}$	$\sqrt{12}$	$\sqrt{12}$
Truth and Error Bit Pattern (example)	T: 000001111 E: 000011111	T: 00000110000 E: 00001100000	T: 0000011001111 E: 0000110011111

Calculation of i-MLSE

For simplifying the numerical expression, we define normalized-SAM (ξ_k) for SAM of the k-th error-pattern as follows;

$$\xi_k \equiv \frac{SAM_k - d_k^2}{2d_k^2} \quad (4.4.1)$$

, where d_k^2 represents the square Euclidean distance of the k-th error-pattern.

i-MLSE is calculated in the following three steps. In the first place, for the purpose of quantifying the quality of the signal, mean value (η_k) of the minus side of ξ_k distribution with respect to its mean value (μ_k) is calculated (Fig. 4.4.3). Under the assumption of the normal distribution for ξ_k , the estimated bER of the k-th error-pattern (ebER_k) and η_k has the relationship as follows;

$$ebER_k = \frac{\rho_k W_k}{2} \operatorname{erfc}\left(\frac{1 + 2\mu_k}{2\sqrt{\pi}(\mu_k - \eta_k)}\right) \quad (4.4.2)$$

, where ρ_k denotes the frequency of the k-th error-pattern, W_k denotes the Hamming distance of the k-th error-pattern and $\operatorname{erfc}(\)$ denotes the complimentary error function. Then, the total estimated bER (ebER_{total}) is obtained by adding each ebER_k for all error-patterns. This manner is very straightforward, but the integration among the different error-patterns can be performed most accurately. Finally, i-MLSE (σ_{i-MLSE}) is obtained by converting ebER_{total} to the equivalent normalized standard deviation (i.e. the jitter value) by following equation;

$$\sigma_{i\text{-MLSE}} \equiv \left\{ 2\sqrt{2} \operatorname{erfc}^{-1} \left(\frac{2 \cdot e b E R_{\text{total}}}{\rho_{\text{total}}} \right) \right\}^{-1} \Leftrightarrow e b E R_{\text{total}} = \frac{\rho_{\text{total}}}{2} \operatorname{erfc} \left(\frac{1}{2\sqrt{2} \sigma_{i\text{-MLSE}}} \right) \quad (4.4.3)$$

, where $\operatorname{erfc}^{-1}(\cdot)$ denotes the operation of the invert function of the complimentary error function.

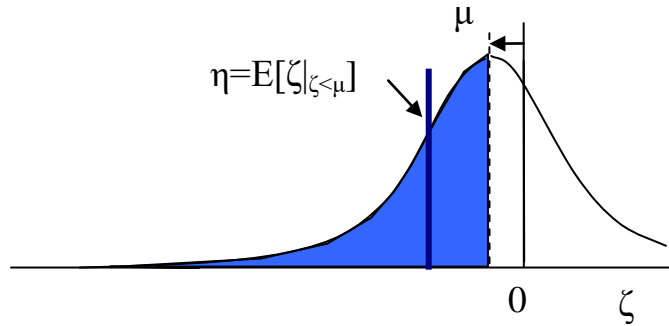

Fig.4.4.3: Signal quality estimation by one-sided mean value of normalized SAM distribution

5. Modulation Code and Error-Correction Code

5.1. Modulation Code

What is a Modulation Code?

Modulation Codes are one of the key elements in optical storage systems such as CD, DVD or BD. In a digital storage system (Fig. 5.1.1), two parts can be distinguished : the transmitting part, including the write Channel in which a user stores data on the disc, and the receiving part, including the read Channel which aims to restore the original information by reading out the data written on the disc.

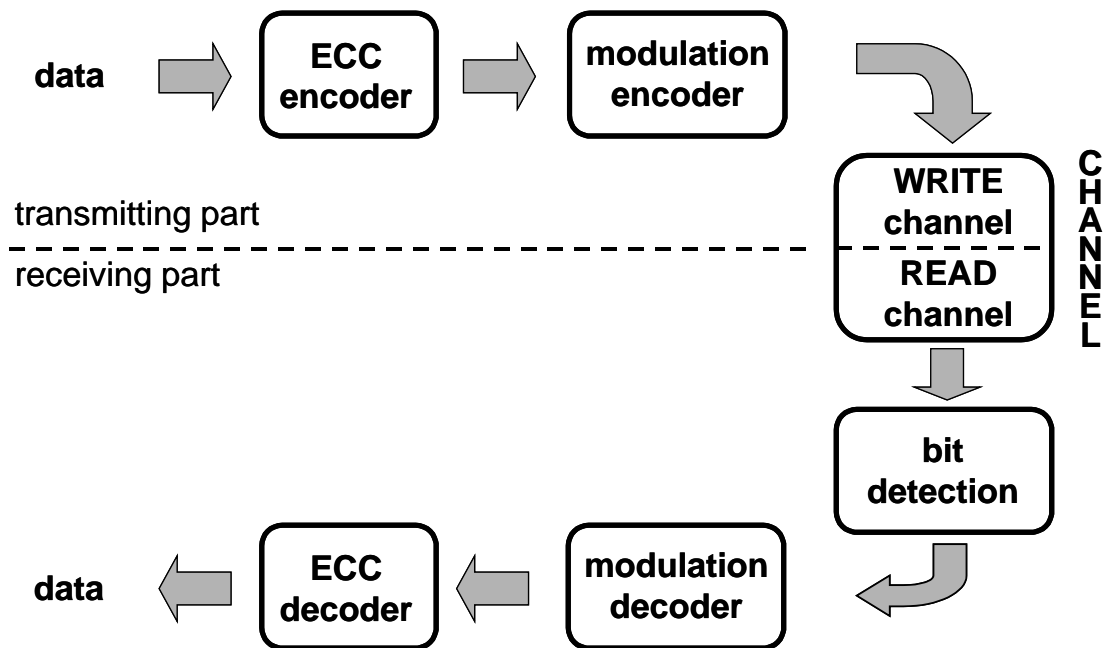

Fig. 5.1.1: Schematic form of digital storage system.

In order to realize a sufficiently high level of reliability, the data is first encoded before being stored. This typically comprises an Error-Correcting Code (ECC) and a Modulation Code (MC). The Channel encoder at the transmitting end consists of the ECC-encoder and the MC-encoder. At the receiving end of the Channel, there is the physical signal detection with the read head scanning the information on the disc, followed by the bit-detection module, which aims to derive the written bits (also called *Channel* bits) from the measured signals as reliably as possible. These blocks precede the Channel decoding, which comprises first the MC-decoder, followed by the ECC-decoder.

The ECC adds redundancy in the form of parity symbols, which makes it possible to restore the correct information in the presence of channel imperfections like random errors and/or burst errors that may occur during read-out from the disc. The Modulation Code serves to transform arbitrary binary sequences into sequences that possess certain "desirable" properties. A very convenient property is that the stored sequences contain neither very short nor very long runs of successive zeros or ones. The reason why this is so originates in how a stored sequence is read from the storage medium.

In optical recording, the modulation of the physical signals is concerned with two physical states of the disc: it is the level of reflectivity (high and low) of the Marks (or *Pits*) and Spaces (or *Lands*). One physical state can be associated with channel bit "1", the other with bit "0". This representation is commonly known as NRZI. An equivalent representation of a Channel-bit stream is the NRZ notation,

where a "1"-bit indicates the start of a new Mark or Space, and a "0"-bit indicates the continuation of a Mark or Space. An NRZI Channel-bit stream can be partitioned into a sequence of *runs*, where each run consists of a number of consecutive Channel bits of the same type. The number of bits in a run is called the *run-length*. A small part of two Tracks on the disc is shown in Fig. 5.1.2. Along the Track, physical Marks and Spaces alternate: their lengths are multiples of the Channel-bit length T .

Very short runs lead to small signal amplitudes in the read-out by the physical detection, and are therefore more prone to errors in the bit-detection module. Moreover, very long runs lead to inaccuracies in the *timing recovery*, which is dealt with by a *Phase-Lock Loop* (PLL). The PLL regenerates the internal bit "clock" by adjusting it at each transition. Areas on the disc with too few transitions may cause "clock-drift". Avoiding very short and/or very long runs is achieved by using a *Run-Length-Limited* (RLL) code, which constrains the allowable minimum and maximum run-lengths that occur in the Channel-bit stream. The RLL constraints are described in terms of two parameters, d and k : the minimum and maximum run-lengths are equal to $d+1$ and $k+1$. For the *uncoded* case, $d=0$ and $k=\infty$. In NRZ notation, a run of length $m+1$ is represented by a "1"-bit followed by m "0"-bits. Hence the (d,k) -constraint in NRZ notation requires that the number of "0"-bits between two successive "1"-bits is at least d and at most k . Most RLL codes are constructed in NRZ notation. Subsequent transformation from NRZ to NRZI yields the Channel bits that are actually written on the disc: this is done by a so-called 1T-precoder, which is an integrator modulo 2 (Fig. 5.1.2). Since the RLL constraints forbid certain specific patterns, it follows that a sequence of source bits must be translated into a longer sequence of Channel bits; the ratio of the length of the original and encoded sequences is called the *rate* of the code.

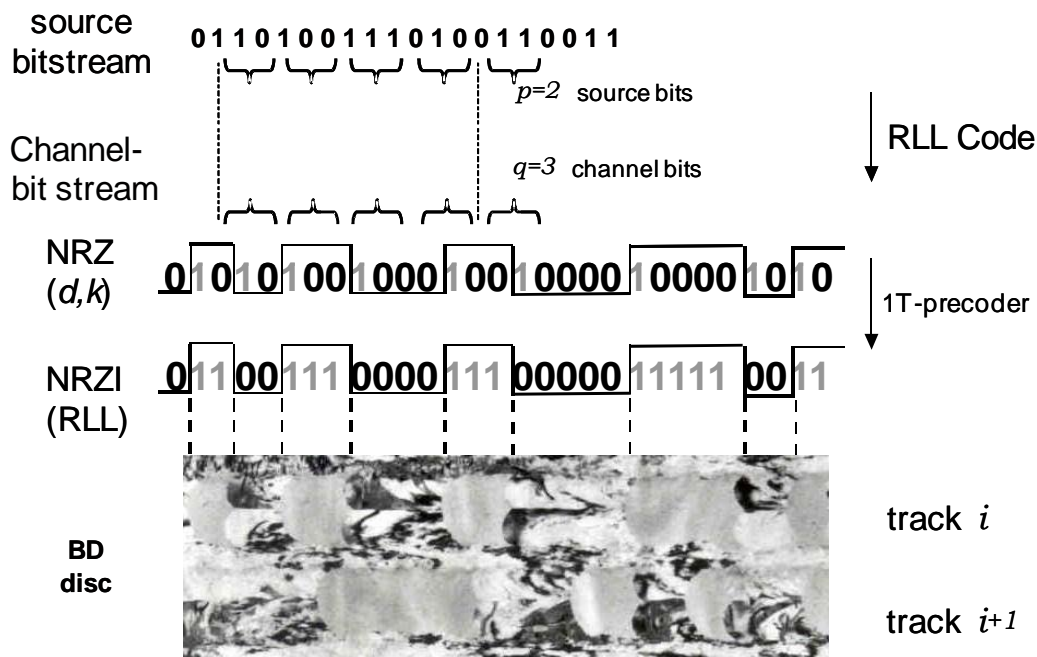

Fig. 5.1.2: RLL $d=1$ coding for BD optical recording.

Why $d=1$ Constraint for BD ?

High-capacity storage applications like BD employ such small bit sizes that the signal waveform generated by the physical detection for a given bit location does not only depend on that single bit, but also on a limited number of neighbouring bits. This bit-smearing effect is better known as *Inter-Symbol Interference* (ISI). The ISI is characterised by the impulse response of the channel, or, equivalently, by its Fourier transform which is known as the Modulation Transfer Function (MTF) of the channel. The MTF indicates the response of the channel for each frequency in the system. In optical recording, the MTF has an almost linear roll-off up to the cut-off frequency of the channel (Fig. 5.1.3).

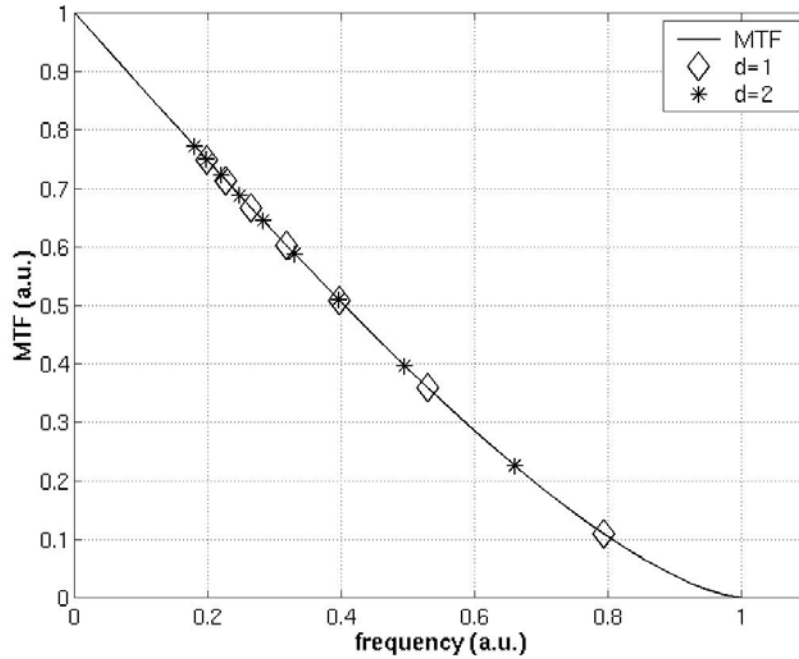

Fig. 5.1.3: MTF for the optical recording channel as a function of frequency (in arbitrary units, with the cut-off at “1”) with the frequencies of the pure tones ... $| nT_d | nT_d |$... superimposed.

Therefore, short run-lengths in the Channel-bit stream, which lead to high-frequency signals, suffer most from ISI and are thus more prone to errors during read-out. One of the purposes of Run-Length-Limited coding is to impose constraints that do not allow these high-frequent bit-sequences. To illustrate this principle, we discuss the effect of employing three different d -constraints, for $d=0$ (uncoded), $d=1$, and $d=2$, while maintaining the same density of *source* bits on the disc. So let T denote the common physical size of a source bit. Using a d -constrained code at a rate R_d , the physical Channel-bit size T_d will necessarily satisfy $T_d = R_d T$. Fig. 5.1.4 shows the respective Channel-bit lengths and the highest frequency in the system (which correspond to an alternation of runs of minimum run-length). Here, we of course have $R_0=1$ in the uncoded case. Furthermore, we assume that practical codes are used that have rates $R_1=2/3$ and $R_2=1/2$, which are close to the maximal achievable code rates of 0.6942 and 0.5515, respectively. The minimum run-length for $d=1$ equals $2T_1=4/3T$, which is larger than the minimum run-length T for $d=0$; also, the minimum run-length for $d=2$ amounts to $3T_2 = 3/2T$, which is larger than the minimum run-length for $d=1$. Consequently, the highest frequencies f_d in the system are

$$f_0 = \frac{1}{2T} > f_1 = \frac{1}{4R_1T} = \frac{3}{8T} > f_2 = \frac{1}{6R_2T} = \frac{1}{3T}.$$

This relation reveals the increasing low-pass character of the code for increasing d constraint, which is the major attractiveness of RLL coding. This becomes also clear from Fig. 5.1.3, which shows the MTF with the frequencies of the pure tones ... $| nT_d | nT_d | nT_d |$... for $n=d+1, d+2, \dots$ superimposed.

However, note that the Channel-bit length (or *timing window*) decreases for increasing d constraint, which leads to a greater sensitivity with respect to *jitter* or *Mark-edge noise* in the system. This counteracting effect favors the use of a *lower* d constraint. The practical choice for the $d=1$ constraint in BD is the optimal compromise between Mark-edge noise (lower d) and ISI (higher d). The k -constraint has been chosen to be $k=7$, from which the acronym “17PP” has been derived.

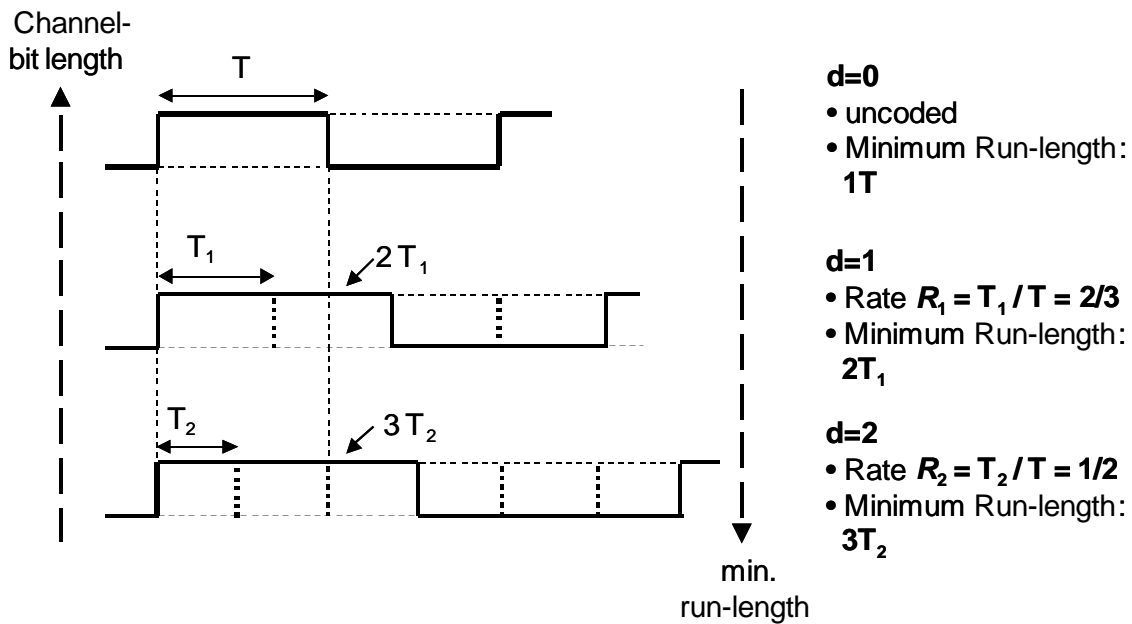

Fig. 5.1.4 Channel-bit length and minimum run-length for different d constraints at the same recording capacity.

Why 17PP “Parity-Preserving” Code?

All RLL codes used in optical recording are *dc-free*, that is, they have almost no content at low-frequencies. We consider NRZI Channel bits b_i with bipolar values ± 1 . A sequence b_1, b_2, \dots is called *dc-free* if its *Running Digital Sum* (RDS; the integral of the bipolar Channel-bit stream)

$$RDS_i = \sum_{j=-\infty}^i b_j$$

takes on only finitely many different values. Then, the power spectral density function vanishes at dc . The *dc-free* property is needed for a number of reasons: (i) for separation of the data signal from disc noise such as fingerprints or dust, (ii) for control of the slicer level, and (iii) for the servo systems.

We shall now discuss a general method to achieve *dc-control* in RLL sequences. The *dc-control* is performed via control of the RDS. A very useful concept herein is the *parity*, the number of ones modulo 2, of a sequence of bits. Recall that an NRZ “1”-bit indicates the start of a new run in the (bipolar) NRZI bit stream. Hence, because of the $1T$ -precoder between NRZ and NRZI Channel-bit streams, each “1”-bit in the NRZ bit stream changes the polarity in the corresponding NRZI bit stream. Consequently, an *odd* number of ones in a segment of the NRZ bit stream *reverses* the NRZI polarity after that segment while an *even* number of ones leaves the polarity unchanged.

The above observation can be used for *dc-control* as follows. Suppose that for a certain segment of the NRZ bit stream, we can choose between two candidate sequences, one with parity “0”, the other with parity “1”. Then the part of the NRZI bit stream *after* this segment will have a contribution to the RDS where the *sign* depends on which of the two sequences is chosen. The *best* choice is of course the one that keeps the value of the RDS as close to zero as possible. We refer to these segments as *dc-control segments*. In order to realise *dc-control*, we have to insert *dc-control segments* at regular positions in the bit stream. Such positions are referred to as *dc-control points*.

A clever and efficient method for *dc-control*, as used in the 17PP modulation code of BD, is via the use of a *Parity-Preserving* code (Fig. 5.1.5). Such a code preserves the parity upon RLL encoding, that is, the parity of a source word is identical to the parity of the corresponding channel word. Single

dc-control bits are inserted (at dc-control points) in the *source* bit stream. Changing a dc-control bit from 0 to 1 changes the parity in the source bit stream and hence also in the NRZ Channel-bit stream: this property enables the selection of the polarity of the NRZI Channel-bit stream, and thus allows for dc-control. The overhead required for each dc-control point in the 17PP code is exactly equal to one source bit, which amounts to the equivalent of 1.5 Channel bits. This makes the 17PP Parity-Preserving $d=1$ code 25 % more efficient at each dc-control point, compared with conventional methods for dc-control.

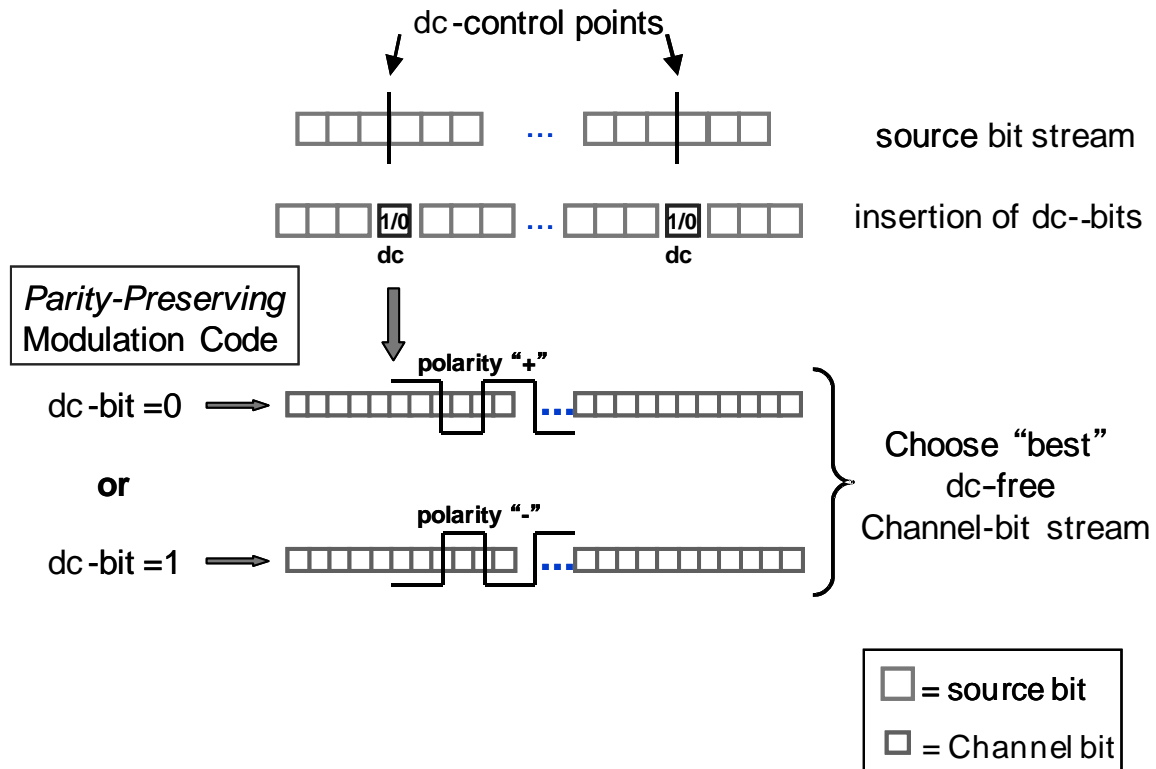

Fig. 5.1.5: Principle of dc-control via *Parity-Preserving* modulation code.

The 17PP code has been designed with one additional favourable property in the sense that it prohibits the occurrence of a large number of consecutive minimum run-lengths ($2T$) which is known as the RMTR constraint. The minimum run-lengths lead to low signal levels, and by restricting their occurrence, the read-out performance is improved.

5.2. Error-Correction Code

In optical recording roughly two types of errors can be distinguished: single or random errors and burst errors. Single errors are caused by noise in combination with other sources of signal deterioration such as tilt of the disc or defocus of the laser spot on the disc. They are called single errors because they only affect one or two bytes. Burst errors are caused by defects on the disc surface like scratches, dust, fingerprints etc.

The Error-Correction system should be adapted to the physical properties of the medium on which the data is stored. Blu-ray Disc™ is, due to its small spot, the thin Cover Layer and the high numerical aperture, more sensitive to burst errors than for instance the DVD system. The same defect on a Blu-ray Disc™ will affect more data bits than on a DVD Disc. The Error-Correction system of Blu-ray Disc™ should therefore be able to cope very well with long burst errors.

The maximum number of errors that can be corrected depends on the number of parity symbols added. For each two parity symbols added, one error can be corrected. This is assuming that nothing is known beforehand about the error. If the location of an error within the code word is known beforehand, only the erased value of the error has to be calculated. For each parity symbol added, one erased value can be calculated, i.e. one erasure can be corrected. So it is advantageous for the error corrector to use prior knowledge of the error locations in the decoding process. Due to the nature of the errors, this is not possible for random errors, but it is very well possible for burst errors. It requires a burst indicator mechanism that can detect bursts of errors before the correction starts.

Blu-ray Disc™ uses an Error-Correction system with a very efficient way of burst indication: a picket code. The structure of such a picket code is shown in Fig. 5.2.1. The pickets are columns that are inserted in between columns of the main data at regular intervals. The main data is protected by a Reed Solomon code that is strong and efficient. The pickets are protected by a second, independent and extremely strong Reed Solomon code. When decoding, first the picket columns are corrected. The correction information can be used to estimate the location of possible burst errors in the main data. The symbols at these locations can be flagged as erasure when correcting the code words for the Main Data. This strategy of applying erasures is shown in Fig. 5.2.1.

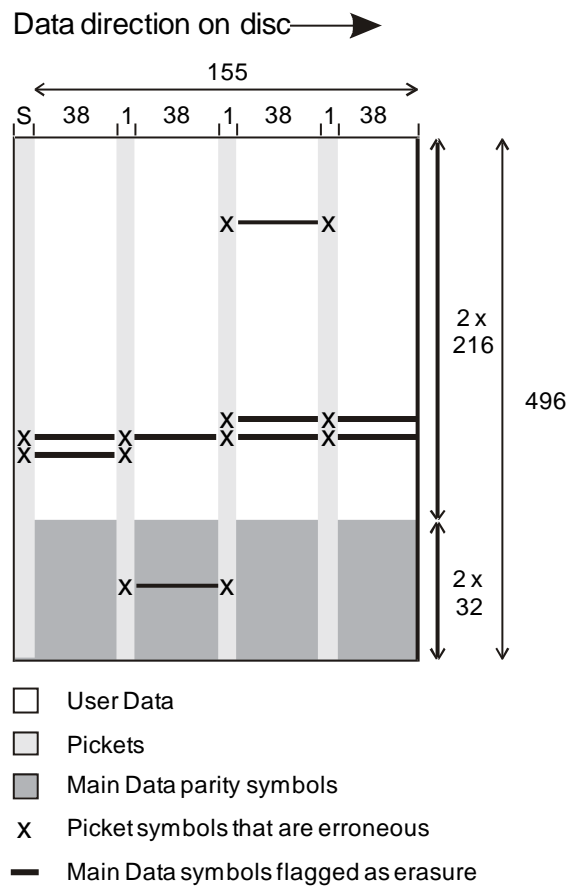

Fig. 5.2.1 Schematic representation of Blu-ray Disc™ picket code

A Blu-ray Disc™ Error-Correction Block (ECC Block) can store 64 kilobytes of User Data. This data is protected by the so called Long-Distance Code (LDC) which has 304 code words with 216 information symbols and 32 parity symbols giving a code word of length 248. These code words are interleaved two by two in the vertical direction such that a block of 152 bytes x 496 bytes is formed as shown in Fig. 5.2.1. A Blu-ray Disc™ ECC block contains 4 equally spaced picket columns. The left most picket is formed by the Sync patterns at the start of each row. If the Sync pattern was not detected properly, that can be an indication for a burst error similar to the knowledge that a symbol of a picket column had to be corrected. The other three pickets are protected by the so-called Burst-Indicating Subcode (BIS). This BIS code has code words with 30 information symbols and 32 parity symbols giving a code word length of 62. The BIS code words are interleaved into three columns of 496 bytes each.

Note that both LDC code and the BIS code have the same number of parity symbols per code word and therefore only one Reed Solomon decoder is required to decode both codes.

The information symbols of the BIS code form an additional Data channel next to the Main Data channel. This side-channel in the BIS columns contains addressing information. The addressing information is protected separately against errors with a Reed Solomon code that has code words with 5 information symbols and 4 parity symbols. This extra code is necessary to allow for fast and robust detection of the addresses, independent of the main ECC.

6. Address format using Groove Wobbles

Address format using Wobbled Groove

The BD-RE, as with CD-R, has a continuous Groove formed spirally on itself for the laser beam to perform tracking control. Its Track Pitch (0.32 μm), however, is smaller than that of CD-R (1.6 μm). The role of this Groove is not just tracking. It is also intended for the generation of write timing for the disc drive. More importantly, in addition, it is used to embed, on an unrecorded Track itself, addresses identifying Track positions in the whole area on the disc and auxiliary information inherent to the disc. For storing those information, the Groove of the BD is modulated by Wobbling. The amplitude of the Wobble modulation is approximately ± 10 nm in a radial direction of the disc.

The Pit address system adopted by DVD-RAM and MO discs was one of the candidates in the investigation stage of address formats for the BD. The Pit address system in general completely separates the reading/writing Data Area from the Address Area. This method ensures very high reliability during and after recording. In contrast, development of the BD format was promoted with a Multi-Layer system in mind since an early stage. Therefore, interlayer influences were thoroughly examined in the selection of the address format. As a result of evaluation, the continuous Groove Wobble system was adopted, as it is thoroughly free of interlayer influences.

The BD-RE writes very small high-density Marks with precision. For this reason, the disc drive requires a highly stable and accurate recording clock signal. Therefore, the fundamental frequency component of Wobbles is a single frequency and the Groove is smooth and continuous. Given a single frequency, it is possible to generate a stable writing clock signal with ease from filtered Wobble components. Since User Data is written always in sync with the Wobbles, the length of one Wobble period is always proportional to the Mark length of written data. Thus the disc capacity is naturally determined by the Wobble size formed on the disc. (For example, the capacity of a Single-Layer disc is 23.3 GB if the Wobble length is 5.52 μm , and 25.0 GB if the Wobble length is 5.14 μm .)

Single frequency-based Wobbles are further modulated in order to add timing and address information. This modulation must be robust against various types of distortion inherent to optical discs. Roughly classified, the following four distortions can occur on optical discs.

- (1) Noise: Groove noise is caused by the Recording Stack and the rough formation of tracking Groove. Data crosstalk noise is caused by Recorded Data.
- (2) Wobble shift: The phenomenon that the position of Wobble detected by the disc drive relatively shifts from the normal position, resulting in decreased detection sensitivity. The Wobble shift tends to occur immediately after seeking.
- (3) Wobble beat: The Wobble beat is produced by Wobble crosstalk of adjacent Track. The cause of the Wobble beat is a shift in angular frequency of adjacent Wobbles in the CLV format.
- (4) Defect: A local flaw such as dust or scratch on disc surface.

A fundamental requirement in the development of the address format of BD was to take measures against all of these different types of distortions. Consequently, the BD uses a combination of two different Wobble modulation systems in a configuration producing synergistic effects without side effects. This combination satisfies all the anti-distortion requirements, an outcome difficult to achieve using only one modulation system. More specifically, the BD has adopted a completely innovative address system combining Minimum-Shift Keying (MSK) modulation and Saw-Tooth Wobble (STW) technology, as explained later. The address format making use of MSK and STW is highly stable against the four types of distortion owing to each basic shape of the Wobble.

Configuration of ADIP Unit and Wobble Groove shapes

Groove Wobbles formed spirally on disc can be divided into units of address information bits embedded in itself (although they are successive), as shown in Fig. 6.1. This is known as the address in Pre-Groove (ADIP) Unit. One ADIP Unit is comprised of 56 Wobbles. Fig. 6.2 shows a schematic diagram of the ADIP Unit expressing "1" and "0" of one bit in address data by the MSK and STW

combination.

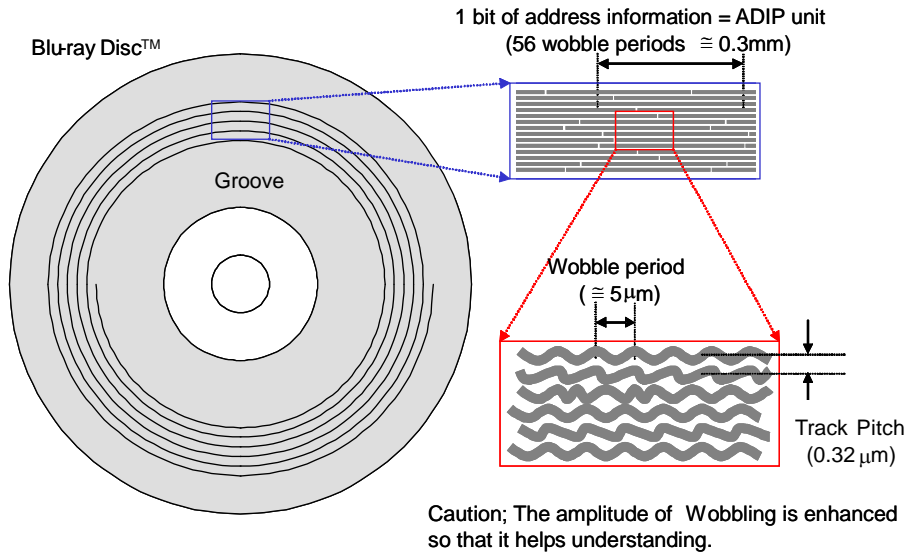

For the tracking of the laser beam, continuous spiral Groove is formed on the disc. The Groove is modulated with Wobbling by cosine, MSK and STW in order to store the address information.

Fig. 6.1

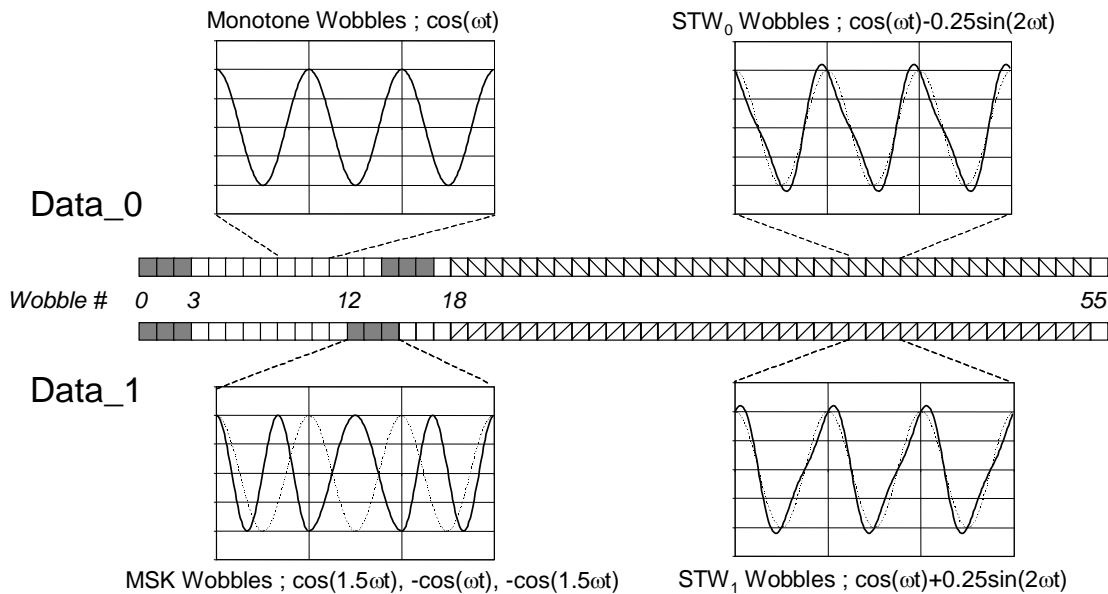

Schematic representation of the ADIP Units for Data_0 and Data_1. An ADIP unit has a length of 56 Wobbles, which contain the first MSK Mark for bit sync, the second MSK Mark characterized by the difference of the position and 37 STWs characterized by the difference of the slope for Data_0 or Data_1.

Fig. 6.2

White Paper Blu-ray Disc™ Format
1A. Physical Format Specifications for BD-RE

6. Address format using Groove Wobbles

The basic units of MSK and STW have the following shapes. The basic unit of MSK Wobbles is three Wobbles. The middle Wobble of them has an inverted polarity in comparison with continuous cosine waves $\cos(\omega t)$ (known as Monotone Wobble) other than MSK, and is sandwiched between cosine waves of a X1.5 frequency $\cos(1.5 \omega t)$. MSK is made up of cosine instead of sine because, in the MSK modulation using phase inversion, smooth waveform connections will be achieved with adjacent Wobbles without a discontinuous section. As a result, MSK requires a small number of frequency bands. As MSK uses one type of waveform alone, differences in waveform position are used as information.

STW waveforms are classified into two types. The waveform of data 0 has edges that rise steeply towards the outer side of the disc and fall gently towards the inner side of the disc. Conversely, the edges of the waveform of data 1 rise gently and fall steeply. The shape resembles saw teeth and that is why STW was so named. Mathematically, STW is expressed by the addition of the fundamental wave $\cos(\omega t)$ and the second harmonic $\sin(2\omega t)$ with a quarter-amplitude. The polarity of the secondary component in the case of data 0 is the inversion of data 1. Characteristically, however, zero-cross points, as in the case of Monotone Wobbles, have no influence on the clock phase reproduced from the fundamental wave component. Although sharp saw teeth can be expressed by the incorporation of higher harmonic components, the limitation to the secondary component makes it possible to keep the required band narrow for the disc mastering unit and to prevent degradation in high-frequency components caused by other signals.

Every ADIP Unit starts with MSK, as shown in Fig. 6.2. The starting MSK called "bit sync" serves as an identifier for the ADIP start point. The difference in the position of the next MSK represents 0 or 1 of data. More specifically, there are successive monotone wobbles between the bit sync and the second MSK, the number being 11 for data 0 and 9 for data 1, a 2-Wobble difference in position. It should be noted that MSK utilizes local phase change of the fundamental wave. In other words, areas of no phase change must be predominant. Those areas are effectively used as STW, of which the phase of the fundamental wave does not change. In an ADIP unit, 37 Wobbles from the 18th to the 54th are modulated by STW. Wobbles representing data 0 have edges rising steeply, and those representing data 1 have edges rising gently and are provided extensively. In order to ensure increased address reliability, the same information is stored in a single ADIP Unit in different MSK and STW formats.

A series of 83 ADIP Units forms an ADIP word expressing an address. One ADIP word contains 12-bit auxiliary data, reference (explained later), Error-Correction Code, as well as 24-bit address information. The BD allocates three ADIP words to each 64-Kbyte Recording Unit Block (RUB) of main data for writing.

Detection methods for and characteristics of MSK and STW

The BD drive unit detects Wobble signals from Push-Pull signals. Fig. 6.3 shows an example of circuit configuration. The drive unit is allowed to use MSK and STW independently or simultaneously to identify ZERO or ONE of an ADIP Unit.

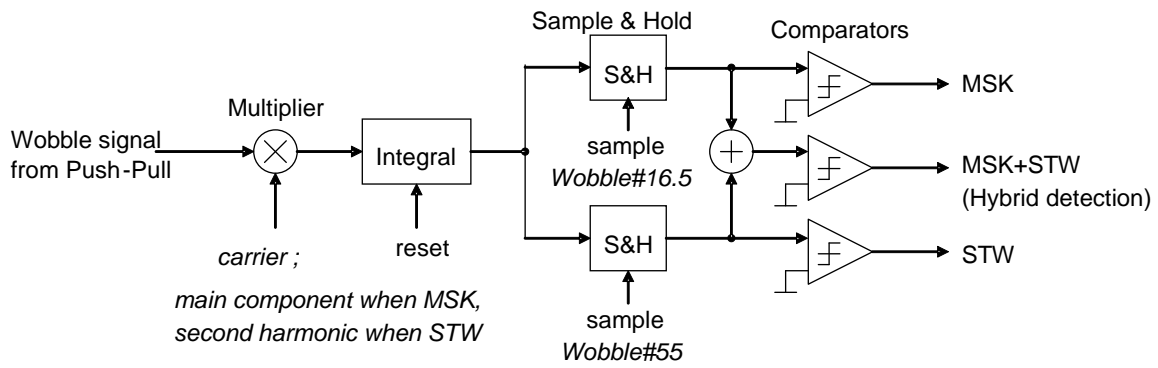

Example of the heterodyne detection circuit for the MSK Marks and the STWs. Both of the MSK Marks and STWs can be detected using the common circuit by only changing frequency of the carrier supplied to the multiplier.

Fig. 6.3

MSK and STW although apparently different can be detected using the same heterodyne circuits (consisting of a carrier multiplier, integrator, sample-and-hold, and comparator). Increased detection performance is achieved by a hybrid detection method in which integrals of MSK and STW are added up.

Their detection methods differ in that MSK uses the fundamental wave (957 KHz) as the carrier for multiplication, while STW used the second harmonic (1, 913 KHz). The only other difference is in the timing signal used to operate each circuit. MSK and STW are highly compatible with each other in terms of detection circuits.

Fig. 6.4 plots the relationship between Wobble shift amount and relative Signal-to-Noise Ratio (SNR) of detection sensitivity, MSK and STW being detected independently. If no Wobble shift occurs on the one hand, the SNR of MSK detection is 1.6 dB higher than STW. A high SNR implies excellent noise immunity. If, on the other hand, a Wobble shift occurs, MSK loses detection sensitivity while the detection sensitivity of STW is stable against ± 3 Wobble shifts. Thus, MSK detection is robust against noise, while STW detection is highly sound to Wobble shifts. These contrasting characteristics originate in the form the location in the Groove.

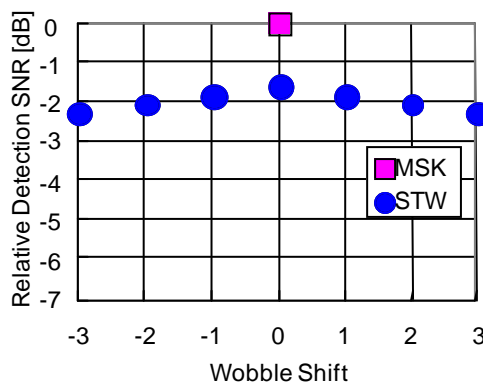

Calculated Signal-to-Noise Ratio for detection of MSK Marks and the STWs using the circuit of Fig.6.3 in case of no cross talk from adjacent Tracks as a function of Wobble shift.

Fig. 6.4

6.Address format using Groove Wobbles

MSK stores information in a local area making use of strong phase change of the fundamental wave and is therefore excellent in SNR. STW is not prone to performance degradation caused by positional shifts as its information is distributed in a wide area spanning 37 cycles. In contrast, MSK provides better position information as bit sync for finding the head of an ADIP Unit. STW laid out in a wide area is insensitive and tough to local defects. An outcome of the combination of MSK and STW in an address format is the achievement of substantial robustness against different types of distortions, such as noise, defects and Wobble shifts, satisfactory high performance for Wobble shifts and correct positioning.

Reference ADIP Unit

Wobble beats, which are beats at the fundamental frequency of Wobbles, occur substantially as the Groove on BD is a narrow-pitched Groove. These beats modulate both the amplitude and phase of the detected single-frequency component. Consequently, detection quality of both MSK and STW degrades due to the beats. Hence the physical length of one Wobble cycle was examined to minimize the influence of beats and was established to be equivalent to 69 writing Channel-clock signals. Furthermore, reference ADIP Units, which are inserted at every 5 ADIP Units, can correct the influence of beats. The reference ADIP Unit is comprised of STW of data 0. Since the Unit is known to be ZERO in advance, it becomes possible to correct a phase shift so that the detected value is precisely data 0.

Experimental results of margin of error

Fig. 5.5 shows bit error rates of ADIP Units for radial tilt in the detection, by MSK only, STW only, and the combination of them, of data on written Track of a test disc. The measurement actually involved all influences such as noise by written data, Wobble shifts, defects, and crosstalk from adjacent Track. Notwithstanding those influences, the system achieved an ADIP bit error rate of 10^{-4} or less regarded necessary for the system, in a wide range. As a matter of practicality, the necessary margin of error of address information is ensured within approximately ± 0.7 degrees of radial tilt. In comparison, the necessary margin of error of address information is ensured in a far wider range, providing high reliability.

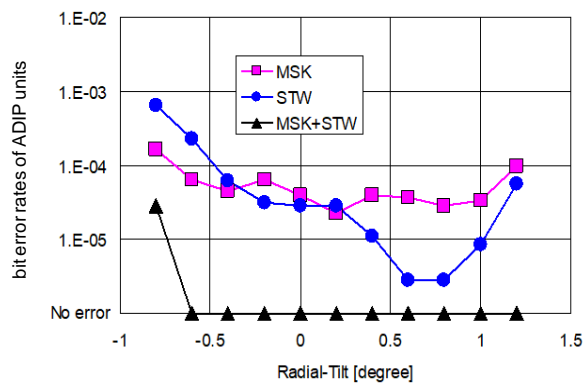

Error rates of ADIP Units of a sample disc as function of radial tilt. The measurements are done with ADIP Units of 3.5×10^5 sample points for written Track. It is enough to perform in the practical use if the error rates are under 10^{-4} .

Fig. 6.5

Reference:

"Wobble-address format of the Blu-ray Disc™", S. Furumiya et al., JJAP, Vol. 42, No. 2B (February 2003)