

Crystal Springs Drive & Griffith Park Drive Safety and Active Transportation Improvements Project

May 24, 2022

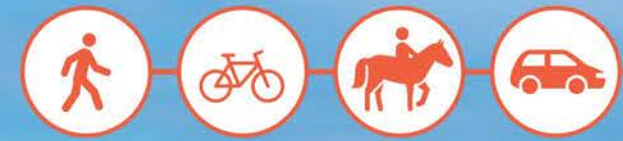



Overview

- Introductions
- Current Issues
- Project Goals
- Study Area
- Data Collection
- Site Visit
- Countermeasure Toolbox
- Discussion



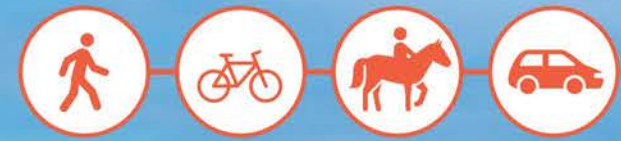

Introductions

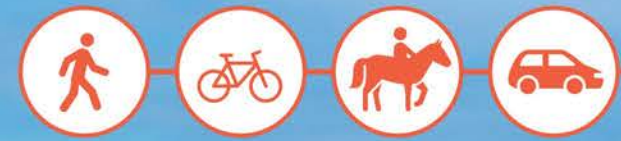

Current Issues

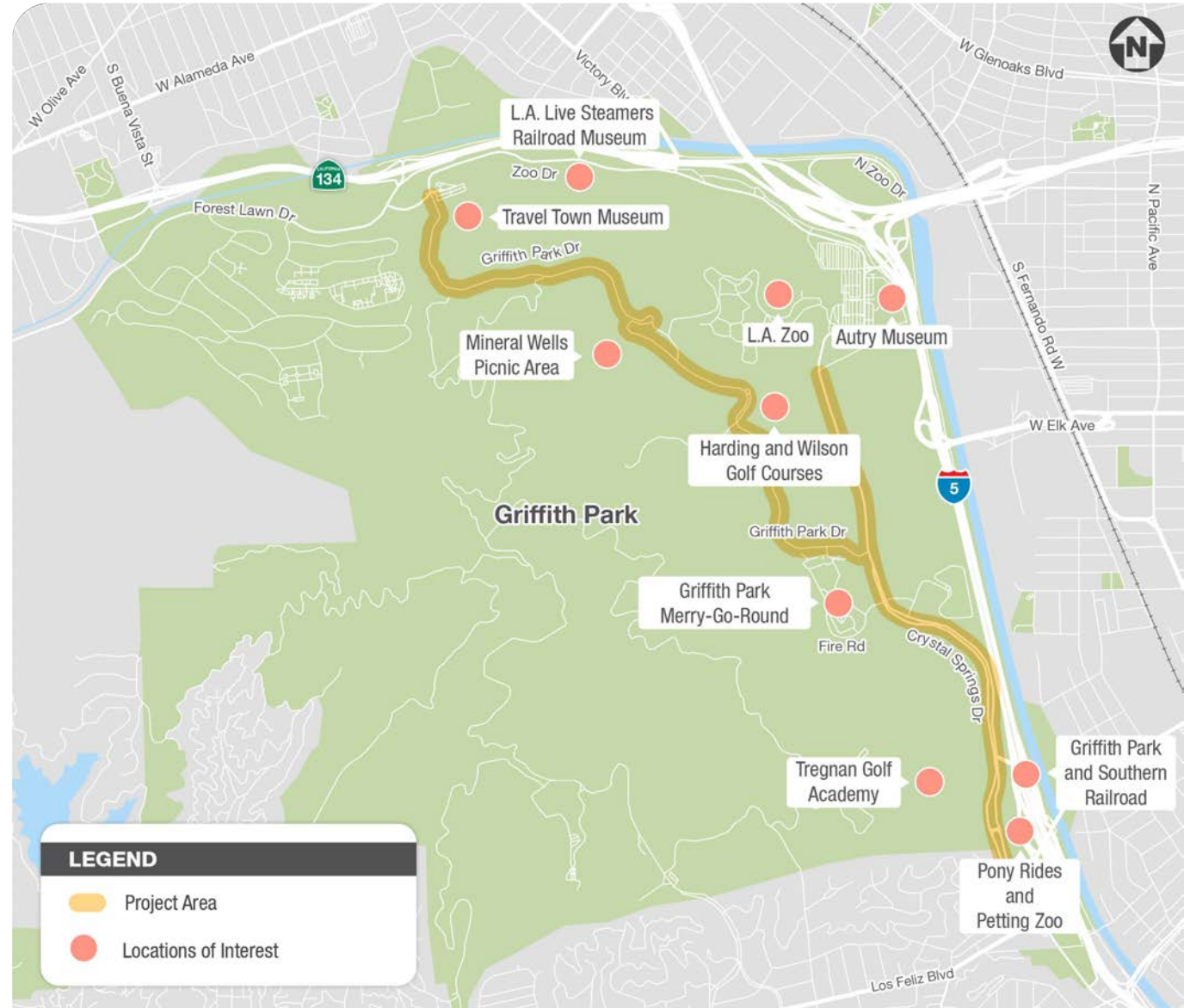
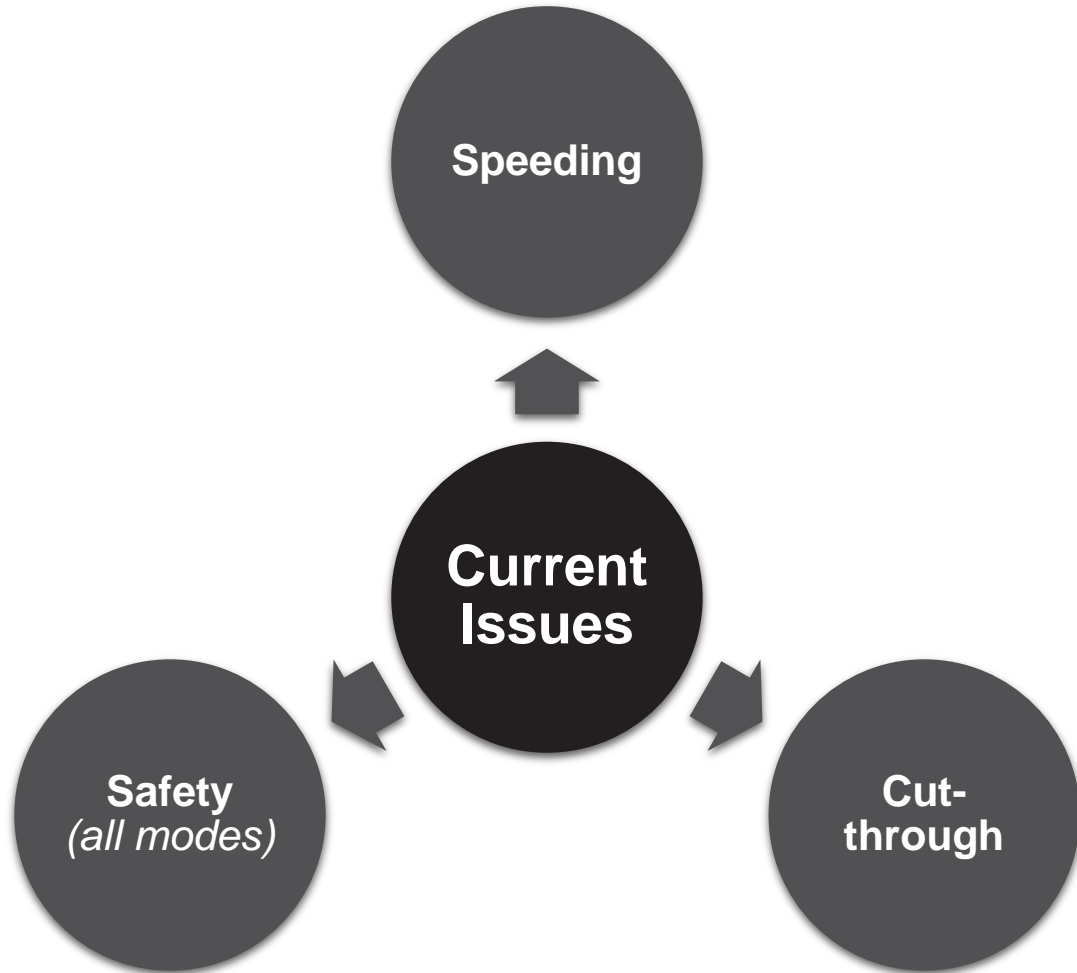

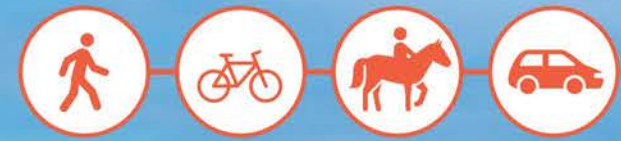

Project Goals

1. **Reduce or eliminate cut-through traffic** through Griffith Park
2. **Traffic Calming**
 - Reduce speeds to 25 mph
3. **Upgrade active transportation**
 - Bike and pedestrian facilities with physical separation



Study Area

- Crystal Springs Drive
 - 2.2 miles
 - Jurisdictional Boundary to Los Feliz Blvd
 - 10 marked crosswalks
 - 25 mph posted speed limit
- Griffith Park Drive
 - 2.6 miles
 - Zoo Dr to Crystal Springs Dr
 - 6 marked crosswalks
 - 25 mph posted speed limit





Study Area

- Crystal Springs Drive
 - 2.2 miles
 - Jurisdictional Boundary to Los Feliz Blvd
 - 10 marked crosswalks
 - 25 mph posted speed limit
- Griffith Park Drive
 - 2.6 miles
 - Zoo Dr to Crystal Springs Dr
 - 6 marked crosswalks
 - 25 mph posted speed limit





Data Collection

- Intersections (8)
 - Peak hour volumes
- Roadway Segments (8)
 - Average daily traffic (one week)
- Speed Surveys



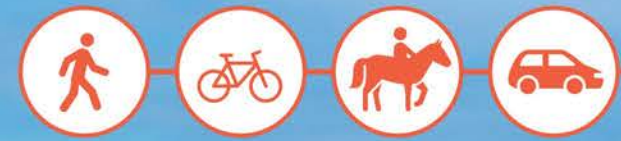

Site Visit

Observe and document:

- Traffic characteristics
- Roadway measurements
- Existing traffic control devices (signs and markings)
- Geometric and utility constraints



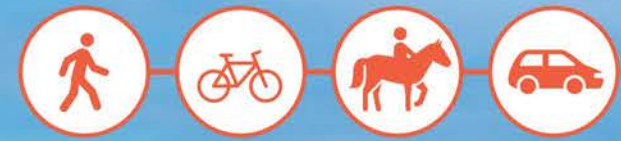

Field Observations

- Speeding
 - High frequency of drivers exceeding posted speed limit (25 mph)
 - Wide travel lanes
 - Conflict Areas
 - *Griffith Park Drive - Speeding drivers and bicyclists conflict with Compost Center vehicles*





Field Observations

- Cut-through Traffic
 - Primarily eastbound
 - Zoo Dr* → Griffith Park Dr → Crystal Springs Dr (A)
 - Zoo Dr* → Crystal Springs Dr (B)

*outside project area

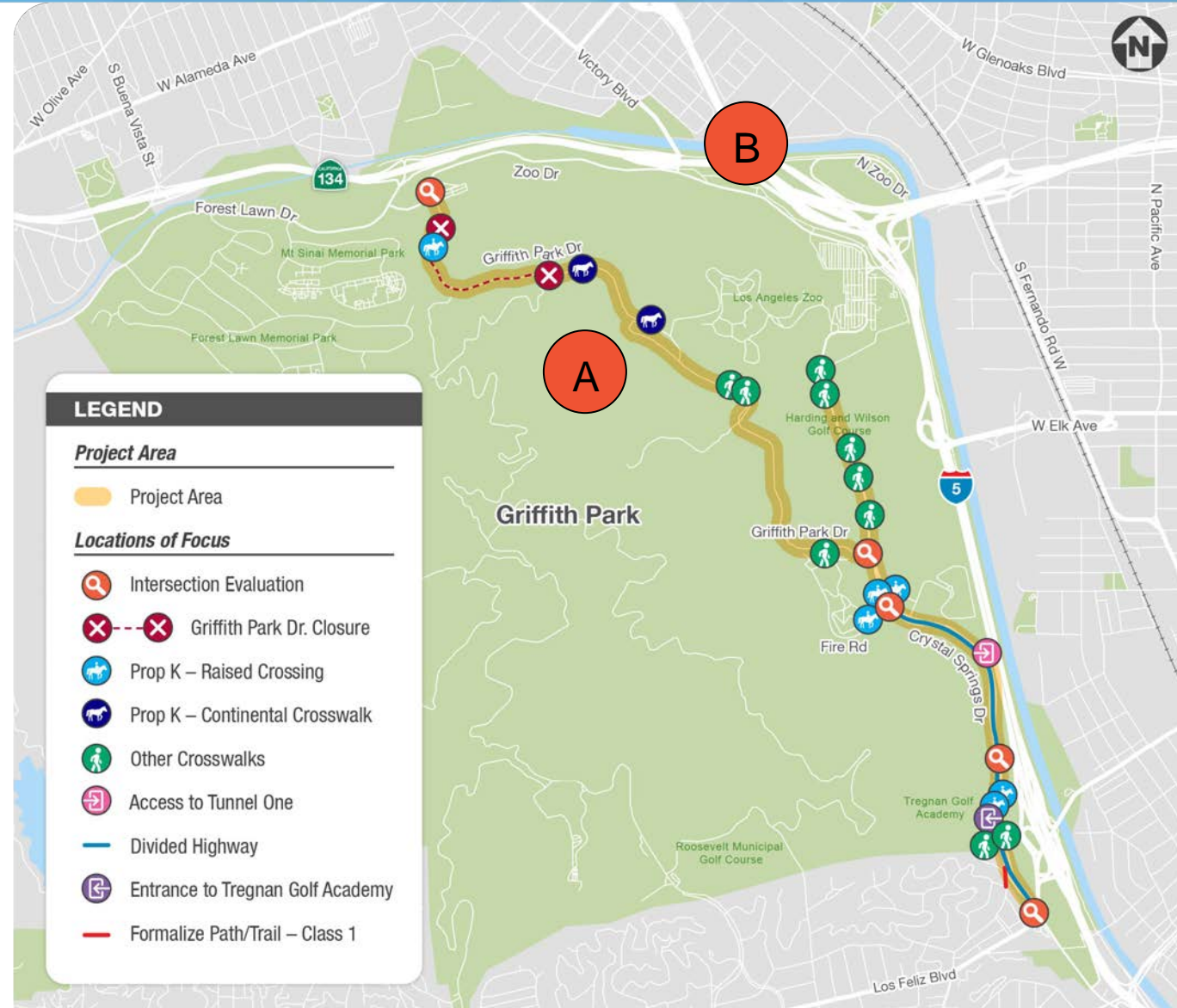

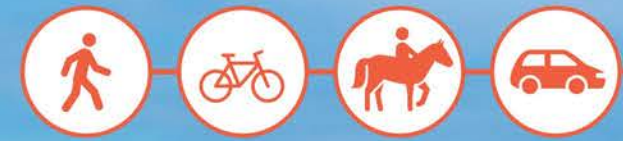

Field Observations

- Potential for Bicycle Facilities Improvements
 - **No physical protection for bike facilities**
 - *Griffith Park currently attracts mostly “strong and fearless” bicyclists*
 - Vehicles parked in bike lanes
 - Street parking and frequent driveway conflicts



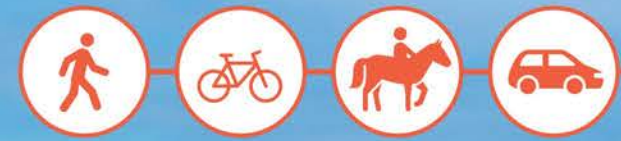

Field Observations

- Potential for Bicycle Facilities Improvements
 - No physical protection for bike facilities
 - *Griffith Park currently attracts mostly “strong and fearless” bicyclists*
 - **Vehicles parked in bike lanes**
 - Street parking and frequent driveway conflicts



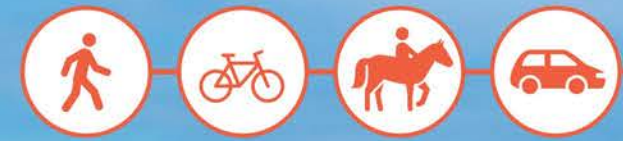

Field Observations

- Potential for Bicycle Facilities Improvements
 - No physical protection for bike facilities
 - *Griffith Park currently attracts mostly “strong and fearless” bicyclists*
 - Vehicles parked in bike lanes
 - **Street parking and frequent driveway conflicts**



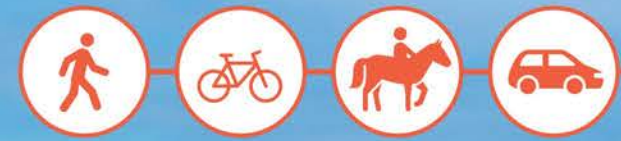

Field Observations

- Potential for Bicycle Facilities Improvements
 - **Limited bicycle facility signing and striping**
 - Poor connections to existing bicycle facilities surrounding project area



R81 (CA)



R4-11



R117 (CA)



D11-1

Figure 9C-9. Shared Lane Marking

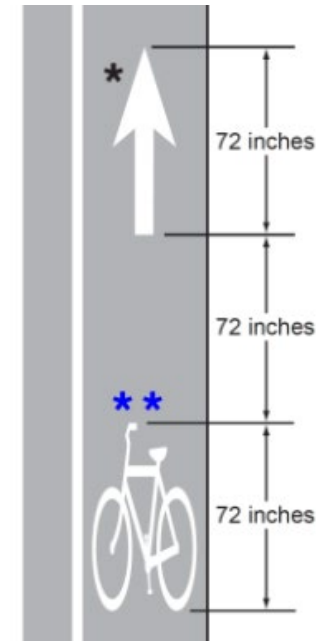
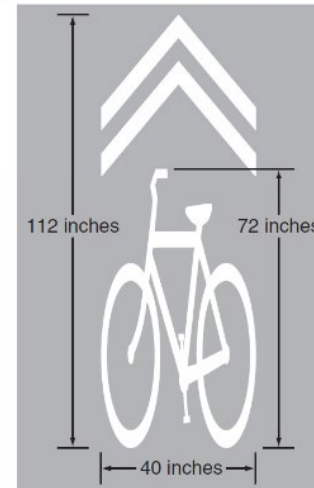

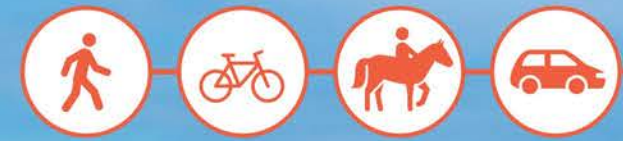

Field Observations

- Potential for Bicycle Facilities Improvements
 - Limited bicycle facility signing and striping
 - **Poor connections to existing bicycle facilities surrounding project area**

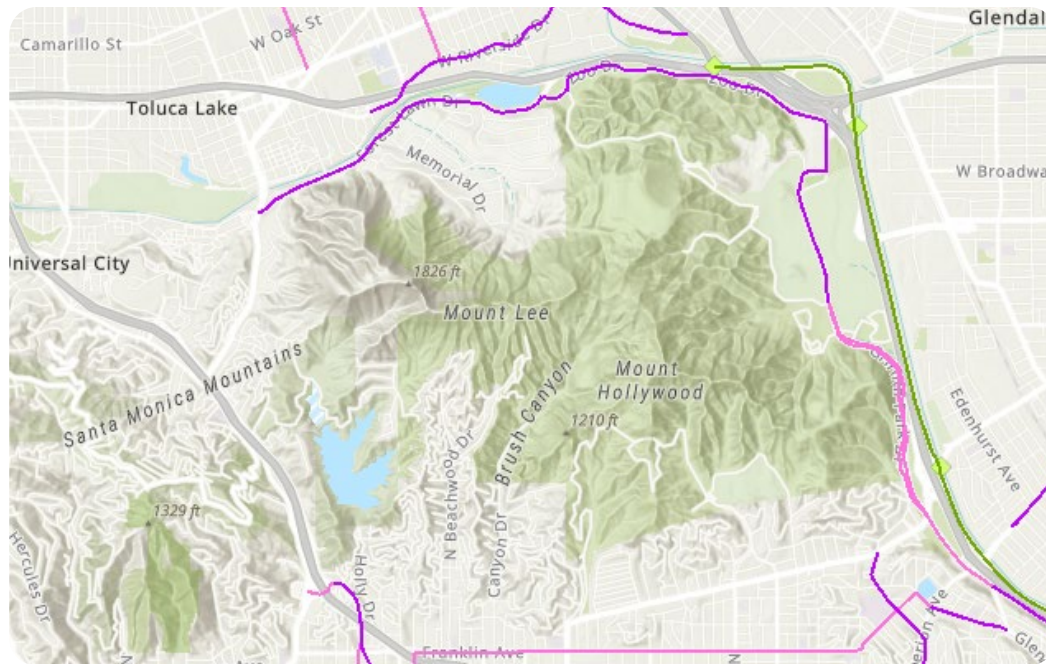

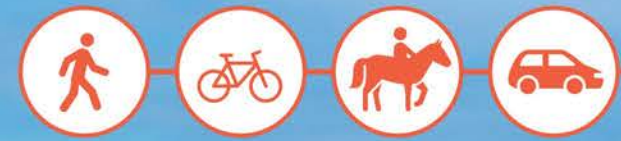

Field Observations

- Potential for Pedestrian Facilities Improvements
 - **Limited sight distance approaching crosswalks**
 - Limited traffic calming devices at crosswalks
 - No paved pedestrian facilities along Crystal Springs Dr



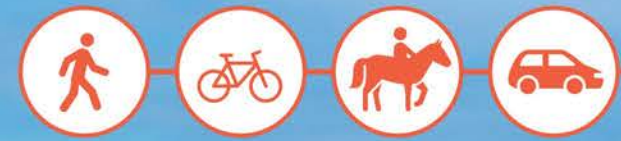

Field Observations

- Potential for Pedestrian Facilities Improvements
 - Limited sight distance approaching crosswalks
 - **Limited traffic calming devices at crosswalks**
 - No paved pedestrian facilities along Crystal Springs Dr



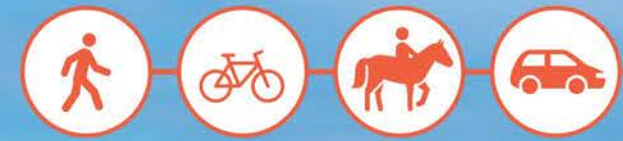

Field Observations

- Potential for Pedestrian Facilities Improvements
 - Limited sight distance approaching crosswalks
 - Limited traffic calming devices at crosswalks
 - **No paved pedestrian facilities along Crystal Springs Dr**



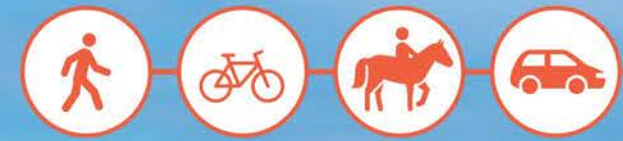

Field Observations

- Traffic Control Device quality
 - **Inconsistent sign type/size**
 - **Signs not retroreflective**
 - Markings are faded



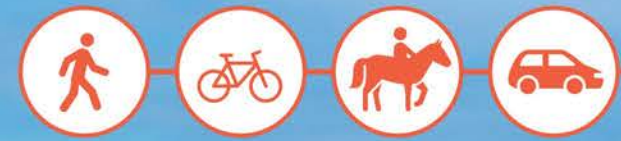

Field Observations

- Traffic Control Device quality
 - Inconsistent sign type/size
 - Signs not retroreflective
 - **Markings are faded**



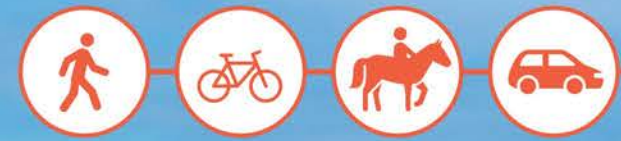

Field Observations

- Parking Considerations
 - 90-degree parking stalls near Golf Course



- Greek Theater Operations
 - Off-Site Parking Needs
 - Shuttle bus use & route

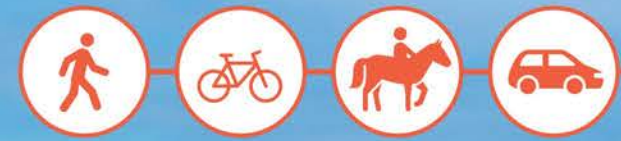

Countermeasures

- Short-Term (< 3 months)
 - Quick implementation (signing/striping)
- Mid-Term (3-12 months)
 - Requires stakeholder/multiple jurisdiction coordination, longer wait time on equipment
- Long-Term (> 12 months)
 - Requires extensive design, longer construction period, major roadway improvements

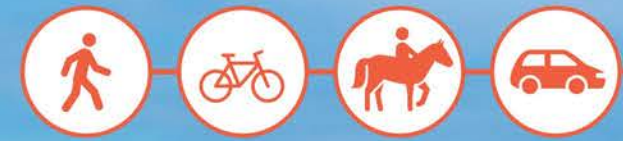

Countermeasure Toolbox – Short-Term (< 3 months)

- Pilot Programs – useful to test before making permanent
- Cut-Through Traffic
 - **GPD – close segment from Travel Town Museum to Mt. Hollywood Drive to motorized road users**
- Speeding
 - Speed Feedback Signs
 - GPD – Stripe double yellow centerline and provide bike lanes (10' vehicle lanes, 8' bike lanes)
- Protected Active Transportation Facilities
 - Restrict on-street parking on CSD
 - *can provide additional parking in overflow lot*

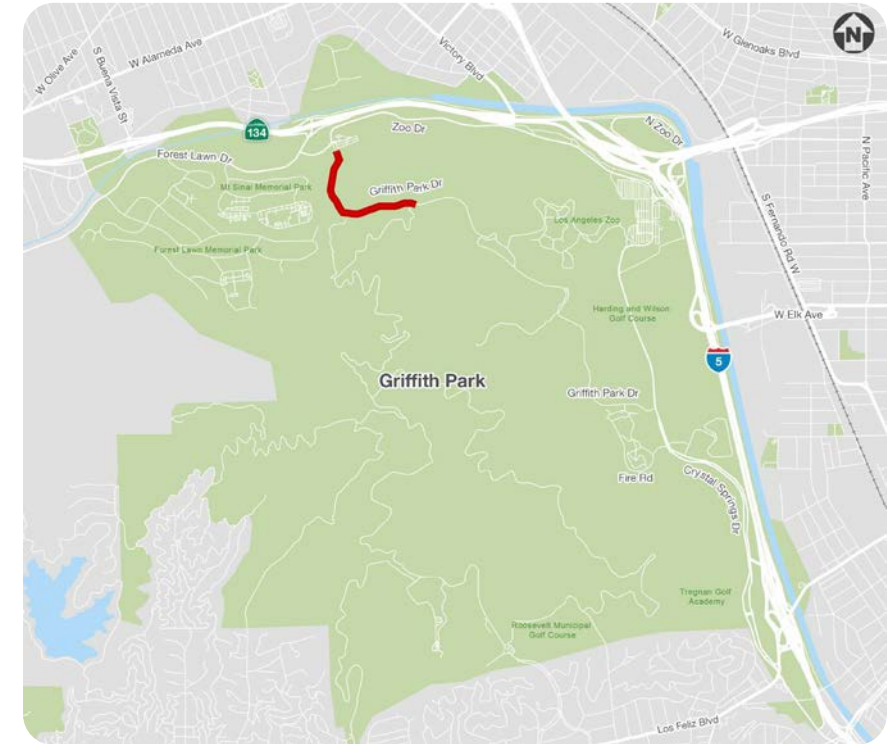



Countermeasure Toolbox – Short-Term (< 3 months)

- Pilot Programs – useful to test before making permanent
- Cut-Through Traffic
 - GPD – close segment from Travel Town Museum to Mt. Hollywood Drive to motorized road users
- Speeding
 - **Speed Feedback Signs**
 - GPD – Stripe double yellow centerline and provide bike lanes (10' vehicle lanes, 8' bike lanes)
- Protected Active Transportation Facilities
 - Restrict on-street parking on CSD
 - *can provide additional parking in overflow lot*

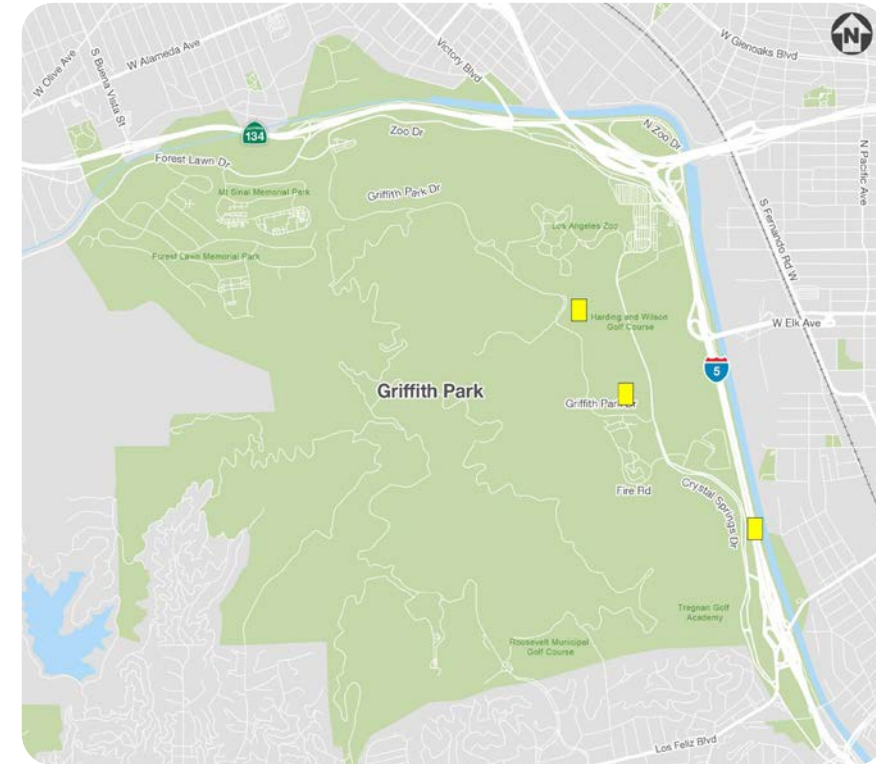



Countermeasure Toolbox – Short-Term (< 3 months)

- Pilot Programs – useful to test before making permanent
- Cut-Through Traffic
 - GPD – close segment from Travel Town Museum to Mt. Hollywood Drive to motorized road users
- Speeding
 - Speed Feedback Signs
 - **GPD – Stripe double yellow centerline and provide bike lanes (10' vehicle lanes, 8' bike lanes)**
- Protected Active Transportation Facilities
 - Restrict on-street parking on CSD
 - *can provide additional parking in overflow lot*

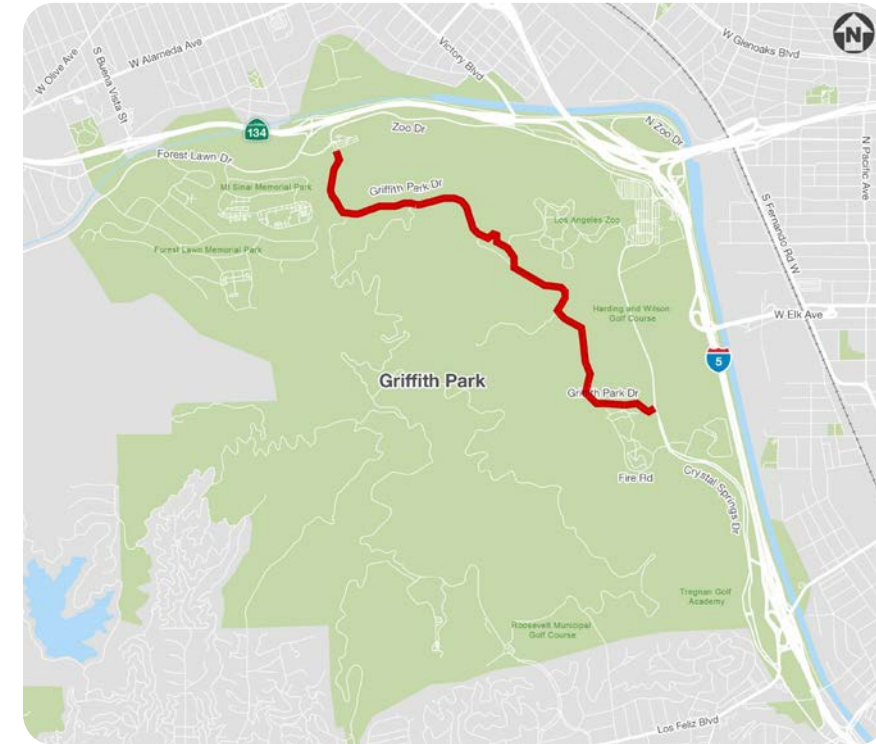



Countermeasure Toolbox – Short-Term (< 3 months)

- Pilot Programs – useful to test before making permanent
- Cut-Through Traffic
 - GPD – close segment from Travel Town Museum to Mt. Hollywood Drive to motorized road users
- Speeding
 - Speed Feedback Signs
 - GPD – Stripe double yellow centerline and provide bike lanes (10' vehicle lanes, 8' bike lanes)
- Protected Active Transportation Facilities
 - **Restrict on-street parking on CSD**
 - *Provide additional parking in overflow lot*

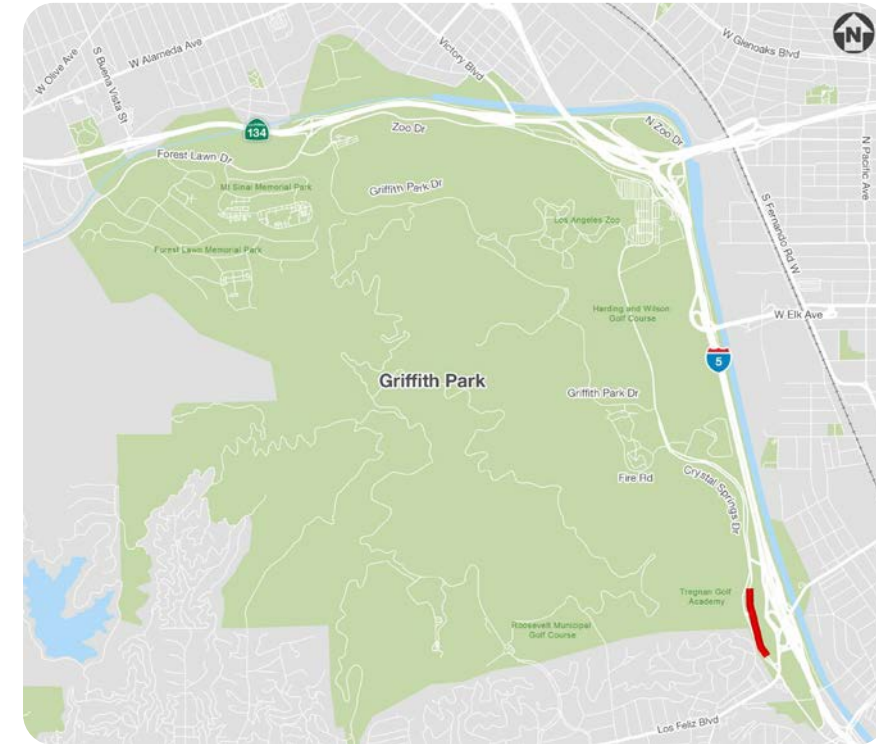



Countermeasure Toolbox – Mid-Term (3-12 months)

- Cut-Through Traffic
 - **I-5 & CSD – Reduce hours when access is allowed from freeway**
 - Restrict access between park and freeway during peak hours at Riverside ramp or Zoo Drive (*outside project area*)
- Speeding
 - CSD – Restripe lanes with narrower widths (10' typical)
 - Install raised crosswalks (for pedestrians and equestrians)
- Protected Active Transportation Facilities
 - CSD – Install buffered bicycle lanes (paint or bollards)
 - CSD – reduce vehicle travel lanes from 2 to 1

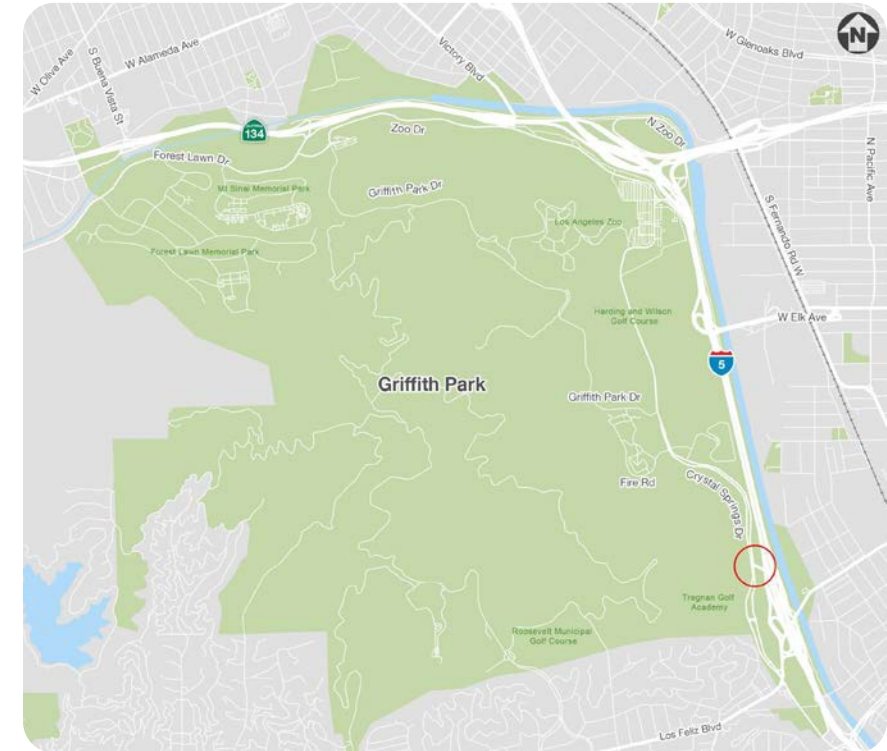



Countermeasure Toolbox – Mid-Term (3-12 months)

- **Cut-Through Traffic**
 - I-5 & CSD – Reduce hours when access is allowed from freeway
 - **Restrict access between park and freeway during peak hours at Riverside ramp or Zoo Drive (outside project area)**
- **Speeding**
 - CSD – Restripe lanes with narrower widths (10' typical)
 - Install raised crosswalks (for pedestrians and equestrians)
- **Protected Active Transportation Facilities**
 - CSD – Install buffered bicycle lanes (paint or bollards)
 - CSD – reduce vehicle travel lanes from 2 to 1

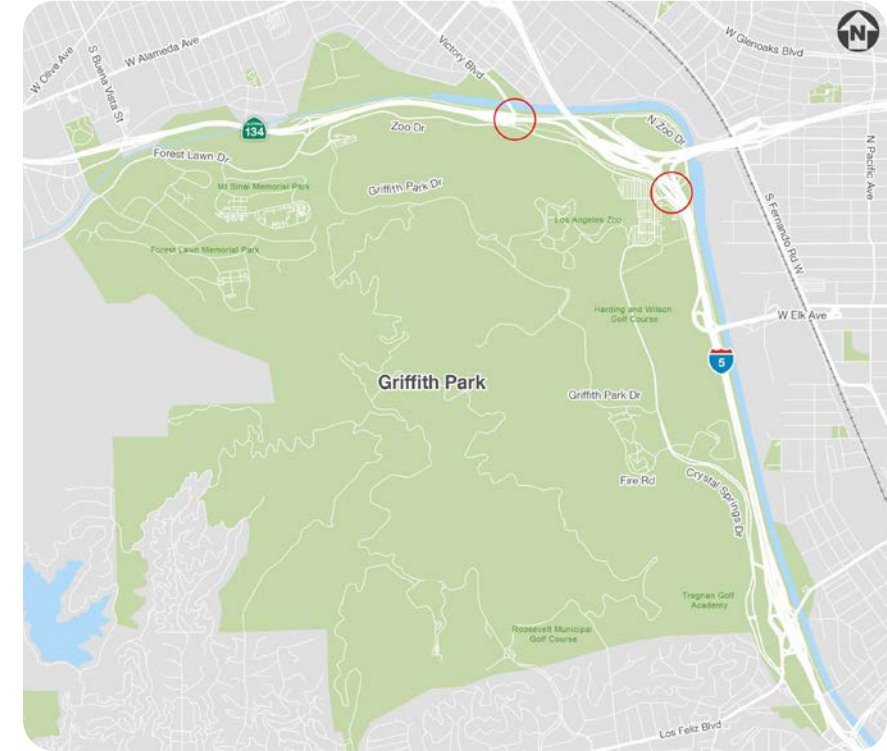



Countermeasure Toolbox – Mid-Term (3-12 months)

- Cut-Through Traffic
 - I-5 & CSD – Reduce hours when access is allowed from freeway
 - Restrict access between park and freeway during peak hours at Riverside ramp or Zoo Drive (*outside project area*)
- Speeding
 - **CSD – Restripe lanes with narrower widths (10' typical)**
 - Install raised crosswalks (for pedestrians and equestrians)
- Protected Active Transportation Facilities
 - CSD – Install buffered bicycle lanes (paint or bollards)
 - CSD – reduce vehicle travel lanes from 2 to 1

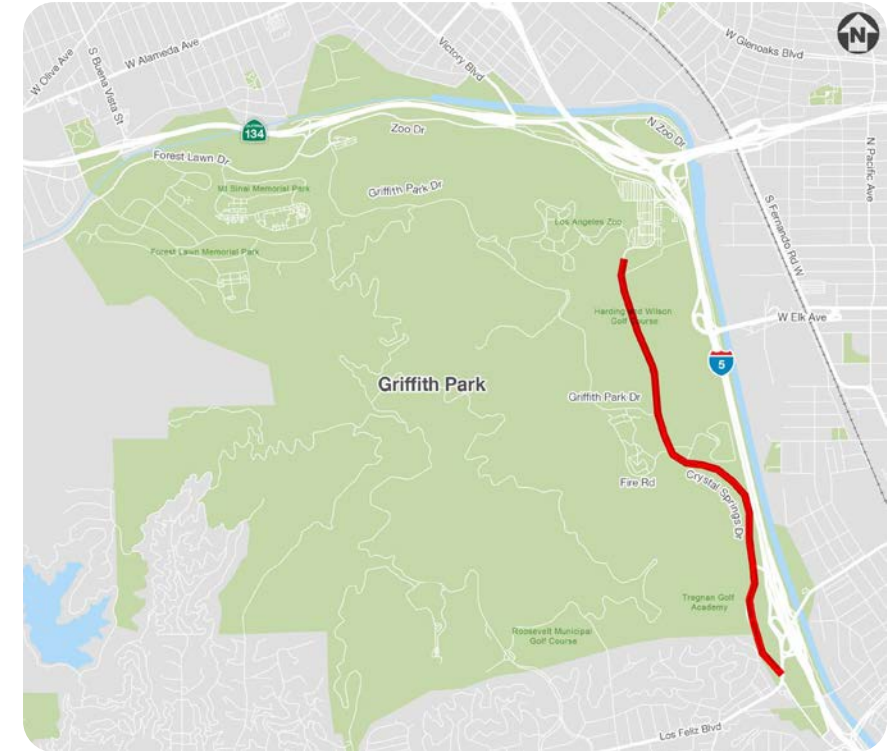



Countermeasure Toolbox – Mid-Term (3-12 months)

- Cut-Through Traffic
 - I-5 & CSD – Reduce hours when access is allowed from freeway
 - Restrict access between park and freeway during peak hours at Riverside ramp or Zoo Drive (*outside project area*)
- Speeding
 - CSD – Restripe lanes with narrower widths (10' typical)
 - **Install raised crosswalks (for pedestrians and equestrians)**
- Protected Active Transportation Facilities
 - CSD – Install buffered bicycle lanes (paint or bollards)
 - CSD – reduce vehicle travel lanes from 2 to 1

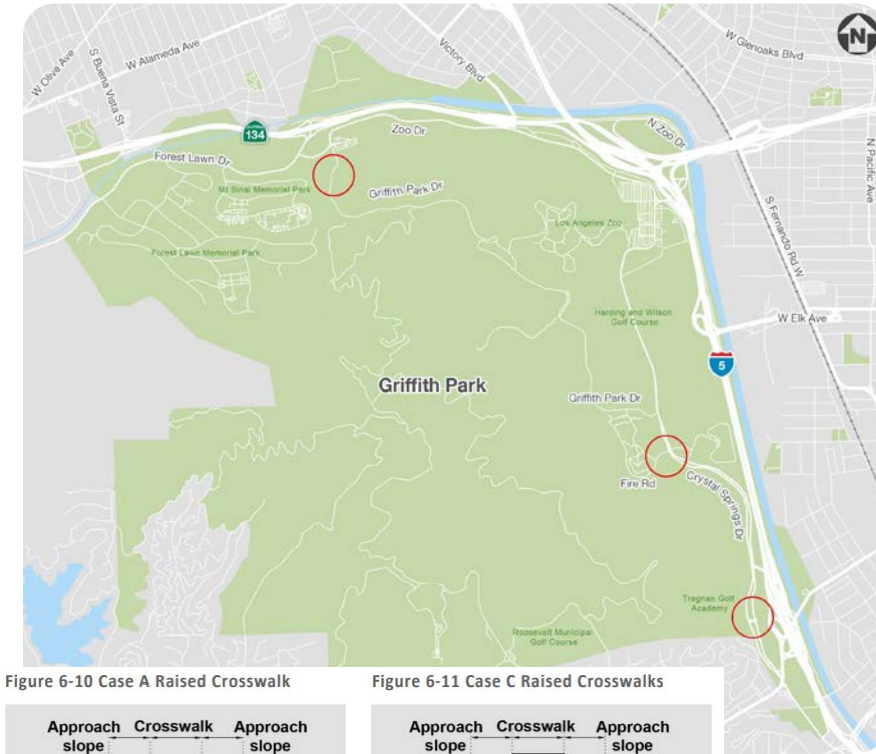

Figure 6-10 Case A Raised Crosswalk

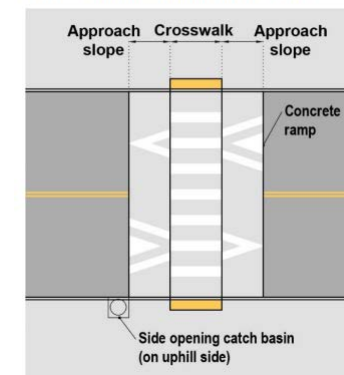
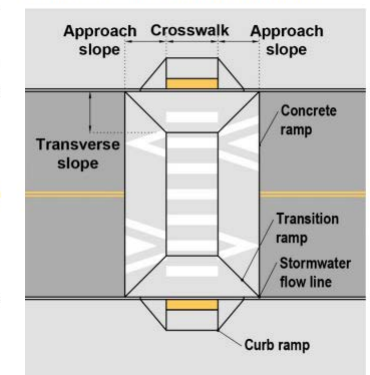

Figure 6-11 Case C Raised Crosswalks





Countermeasure Toolbox – Mid-Term (3-12 months)

- Cut-Through Traffic
 - I-5 & CSD – Reduce hours when access is allowed from freeway
 - Restrict access between park and freeway during peak hours at Riverside ramp or Zoo Drive (*outside project area*)
- Speeding
 - CSD – Restripe lanes with narrower widths (10' typical)
 - Install raised crosswalks (for pedestrians and equestrians)
- Protected Active Transportation Facilities
 - **CSD – Install buffered bicycle lanes (paint or bollards)**
 - CSD – reduce vehicle travel lanes from 2 to 1

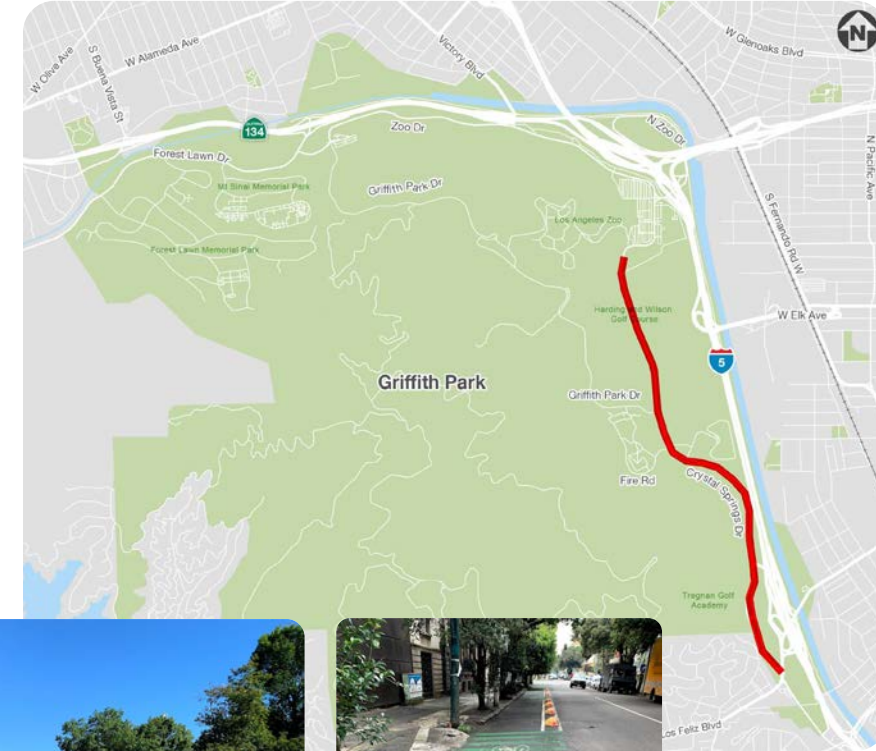



Countermeasure Toolbox – Mid-Term (3-12 months)

- Cut-Through Traffic
 - I-5 & CSD – Reduce hours when access is allowed from freeway
 - Restrict access between park and freeway during peak hours at Riverside ramp or Zoo Drive (*outside project area*)
- Speeding
 - CSD – Restripe lanes with narrower widths (10' typical)
 - Install raised crosswalks (for pedestrians and equestrians)
- Protected Active Transportation Facilities
 - CSD – Install buffered bicycle lanes (paint or bollards)
 - **CSD – reduce vehicle travel lanes from 2 to 1**

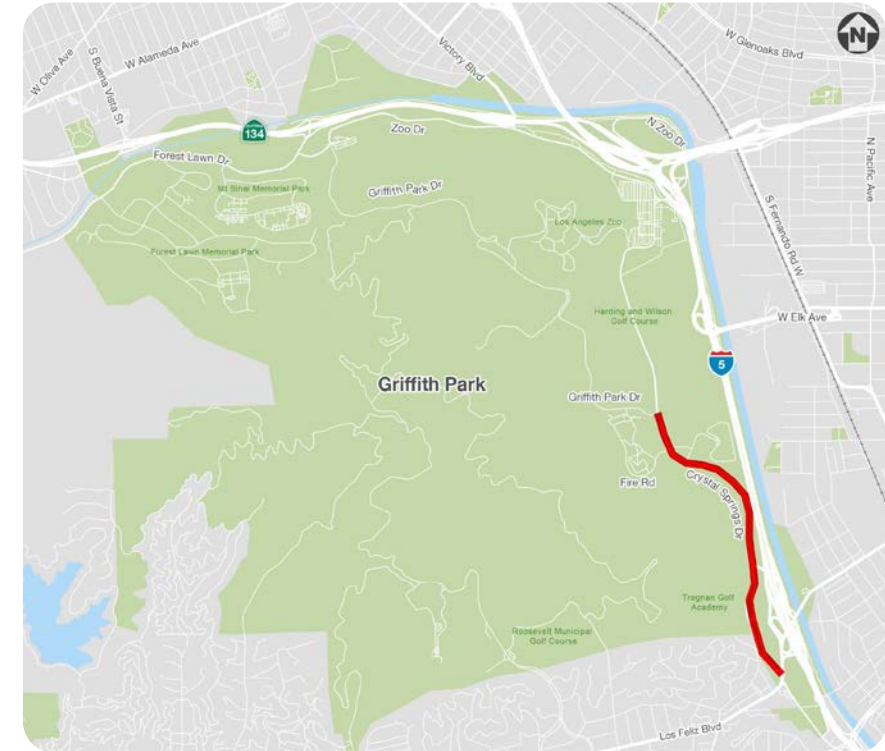



Countermeasure Toolbox – Long-Term (> 12 months)

- Cut-Through Traffic
 - **I-5 Ramps and CSD – Close ramp access to park**
- Speeding
- Protected Active Transportation Facilities
 - CSD – close “upper” roadway to motorized road users
 - CSD – provide paved connection to Griffith Park Boulevard via path
 - CSD – provide paved connection to LA River Trail via tunnel
- Other Ideas
 - Improve quality of bus stops to promote use of transit to park

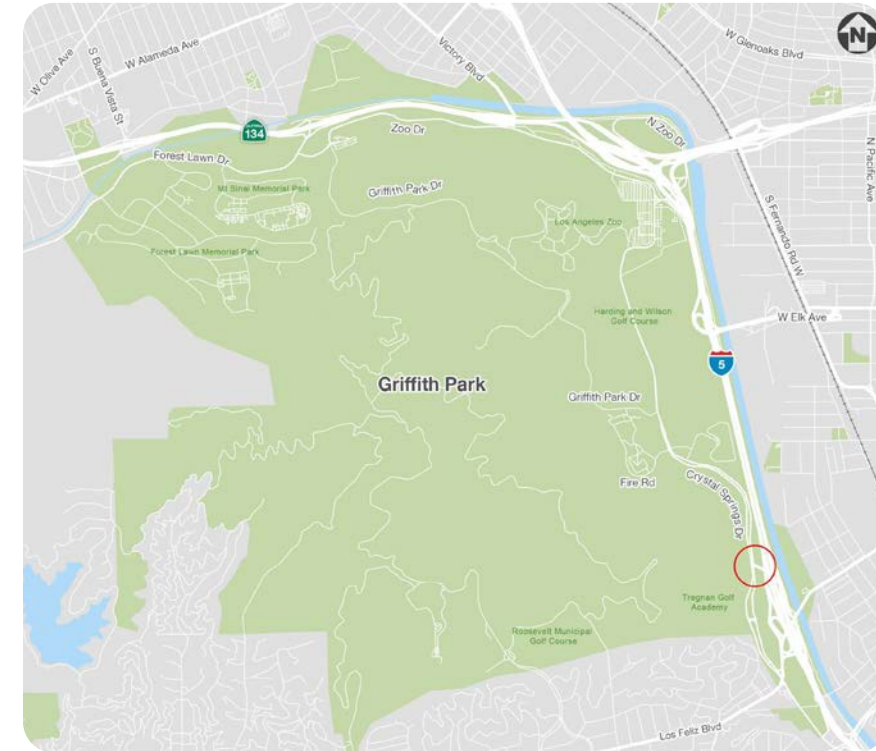



Countermeasure Toolbox – Long-Term (> 12 months)

- Cut-Through Traffic
 - I-5 Ramps and CSD – Close ramp access to park
- Speeding
- Protected Active Transportation Facilities
 - **CSD – close “upper” roadway to motorized road users**
 - CSD – provide paved connection to Griffith Park Boulevard via path
 - CSD – provide paved connection to LA River Trail via tunnel
- Other Ideas
 - Improve quality of bus stops to promote use of transit to park

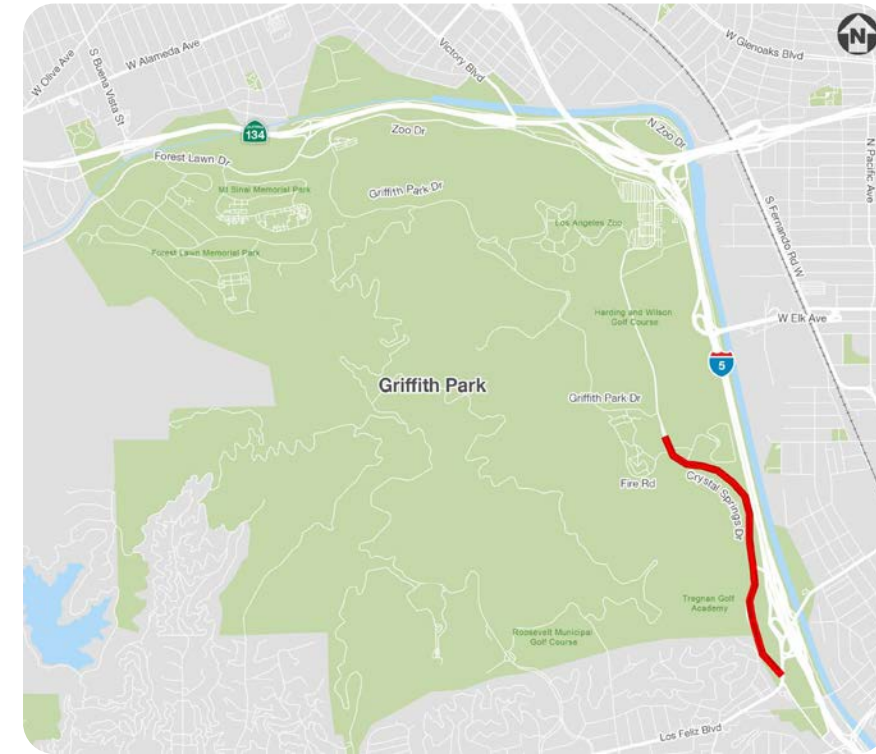



Countermeasure Toolbox – Long-Term (> 12 months)

- Cut-Through Traffic
 - I-5 Ramps and CSD – Close ramp access to park
- Speeding
- Protected Active Transportation Facilities
 - CSD – close “upper” roadway to motorized road users
 - **CSD – provide paved connection to Griffith Park Boulevard via path**
 - CSD – provide paved connection to LA River Trail via tunnel
- Other Ideas
 - Improve quality of bus stops to promote use of transit to park

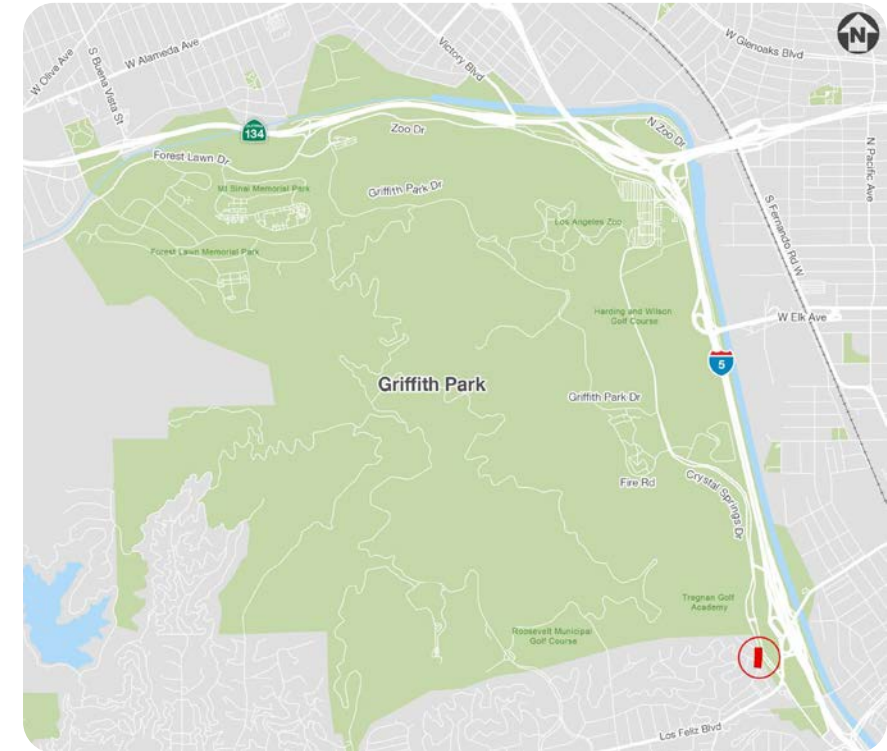



Countermeasure Toolbox – Long-Term (> 12 months)

- Cut-Through Traffic
 - I-5 Ramps and CSD – Close ramp access to park
- Speeding
- Protected Active Transportation Facilities
 - CSD – close “upper” roadway to motorized road users
 - CSD – provide paved connection to Griffith Park Boulevard via path
 - **CSD – provide paved connection to LA River Trail via tunnel**
- Other Ideas
 - Improve quality of bus stops to promote use of transit to park

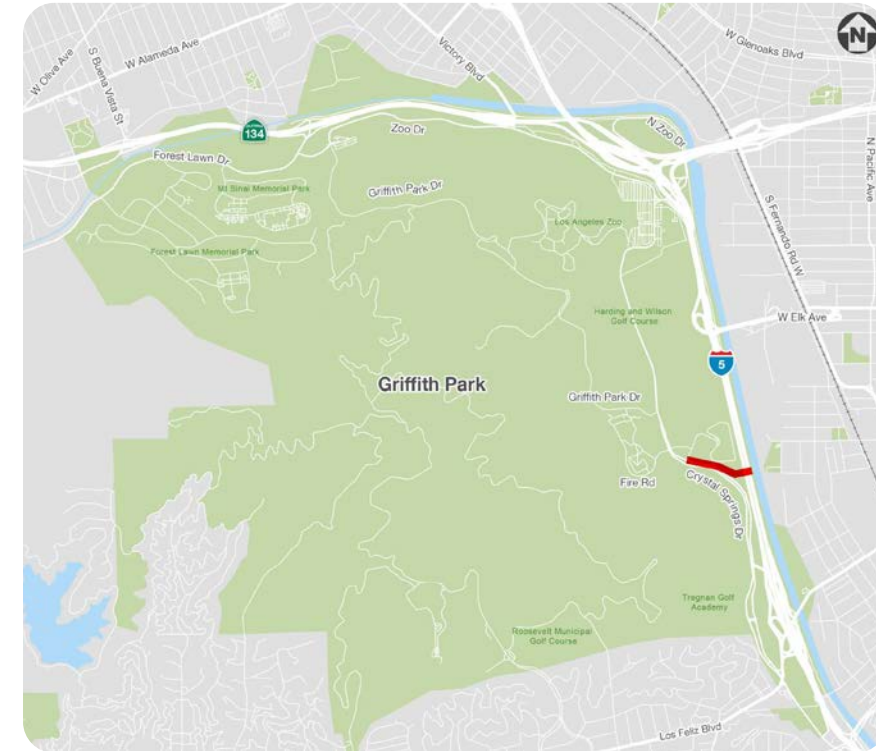



Countermeasure Toolbox – Long-Term (> 12 months)

- Cut-Through Traffic
 - I-5 Ramps and CSD – Close ramp access to park
- Speeding
- Protected Active Transportation Facilities
 - CSD – close “upper” roadway to motorized road users
 - CSD – provide paved connection to Griffith Park Boulevard via path
 - CSD – provide paved connection to LA River Trail via tunnel
- Other Ideas
 - **Improve quality of bus stops to promote use of transit to park**

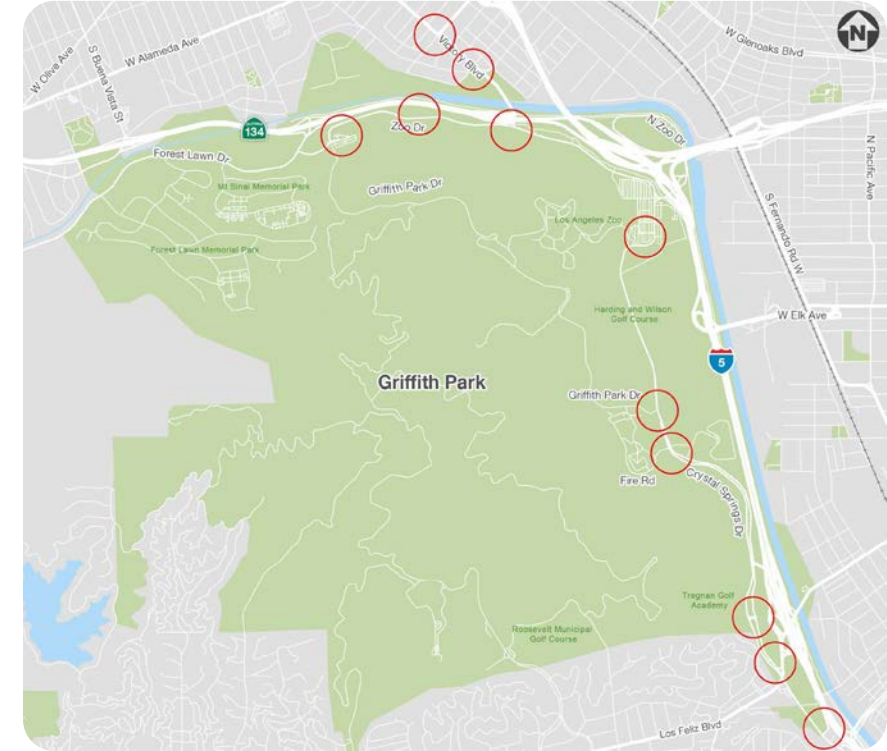

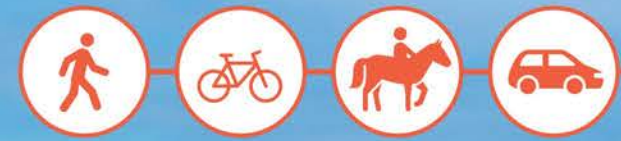

Discussion

- Which countermeasures will **NOT** work?
- What other issues need to be addressed?



Crystal Springs Drive & Griffith Park Drive Safety and Active Transportation Improvements Project

May 24, 2022

Thank You!

