

EMBRAER 190



Flight Controls

DO NOT USE FOR FLIGHT

INTRODUCTION

The Flight Control System is comprised of the primary and the secondary flight control systems and their associated system components.

The primary flight control system consists of:

- Ailerons and the multi function roll spoilers for roll axis control.
- Elevators for pitch axis control.
- Rudder for yaw axis control.

The secondary flight control system consist of:

- Horizontal stabilizer.
- Flaps and Slats.
- The multi-function spoiler (when used as speed brakes or ground spoilers).
- Dedicated ground spoilers.

Hydraulic actuators control the respective flight control surfaces. These are generally referred to as Power Control Units (PCUs).

The ailerons are driven by conventional control cables that run from each control wheel back to a pair of hydro-mechanical actuators.

Elevators, rudders and roll spoilers as well as all secondary flight control systems, including the horizontal stabilizer, flaps and slats, ground spoilers and speed brakes, are controlled electronically using Fly-by-Wire (FBW) technology.

The primary flight control electronics are generally comprised of two complementary parts:

- The Primary Actuator Control Electronics (P-ACE).
- The Flight Control Module (FCM).

Primary Actuator Control Electronics (P-ACE) and/or Flight Control Modules (FCM) are employed to operate the respective electro-hydraulic or electro-mechanical actuators.

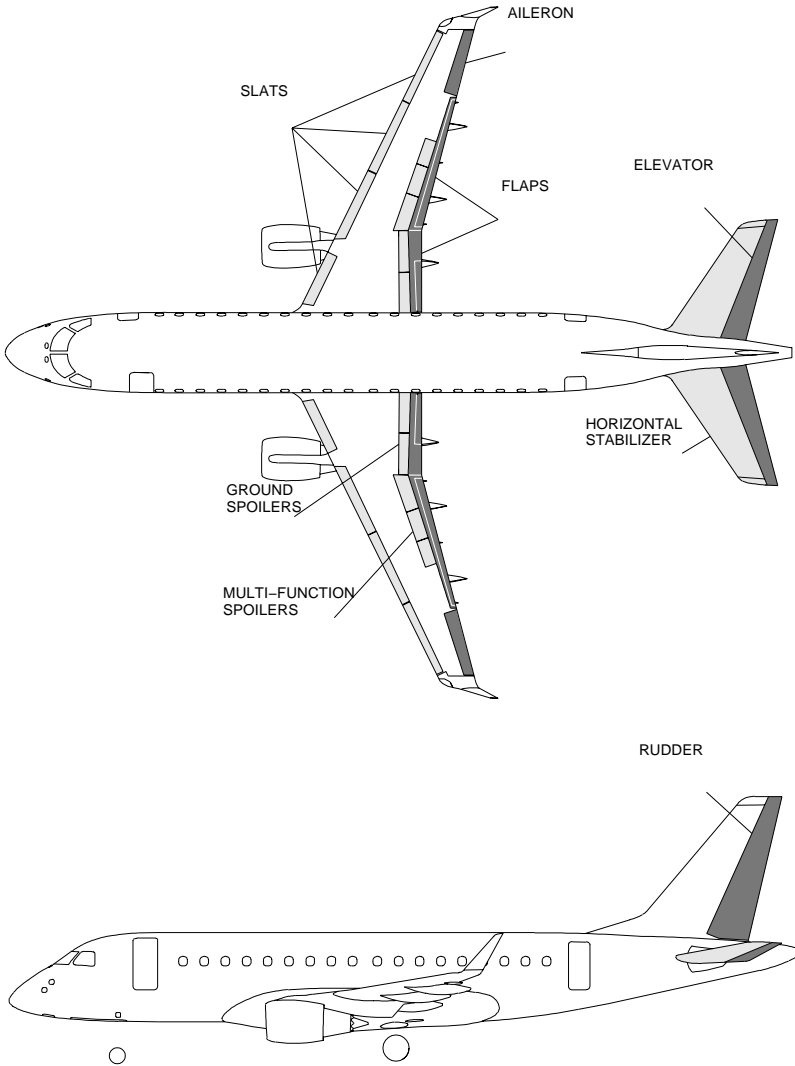

CONTROL SURFACE LOCATION

CONTROLS AND INDICATIONS

CONTROL WHEEL

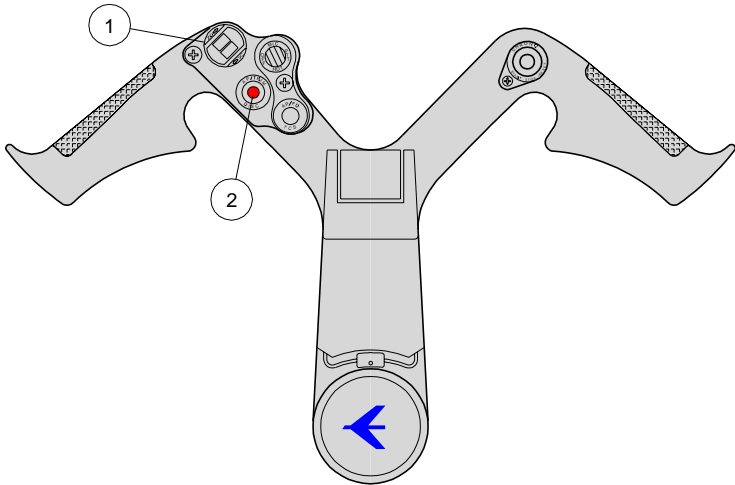

1 – PITCH TRIM SWITCH (SPRING-LOADED TO NEUTRAL)

- Trims the airplane when the autopilot is not engaged.

NOTE: Captain's pitch trim switch actuation has priority over the first officer's.

2 – AP/TRIM DISCONNECT BUTTON (MOMENTARY ACTION)

- Disable both HS-ACE channels as long as the switches remain pressed, thus disconnecting the autopilot and stopping any active trim command.
- Releasing the switch will activate the channel again.

SLAT/FLAP SELECTOR LEVER

CONTROL
PEDESTAL

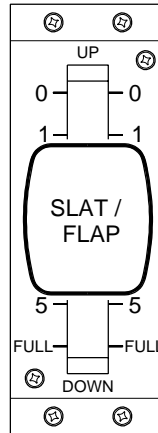
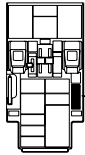

- Selects slat/flap position by unlatching the lever and lifting a trigger below the head.
- Intermediate positions are not enabled. If lever is left at an intermediate position, flaps/slats remain in the last selected position. Position 4 is gated for normal Go Around and Takeoff. Position 5 is used for landing.

Lever position	Slat position	Flap Position	Detent/Gated
0	0°	0°	Detent/Stop
1	15°	7°	Detent
2	15°	10°	Detent
3	15°	20°	Detent
4	25°	20°	Gated/Stop
5	25°	20°	Detent
Full	25°	37°	Detent/Stop

SPEED BRAKE LEVER

CONTROL
PEDESTAL

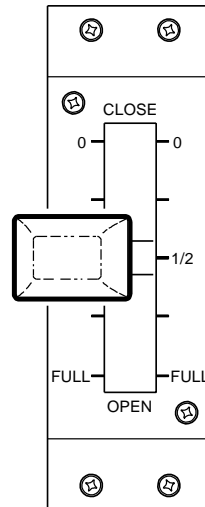
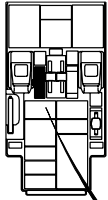

- Symmetrically deploys the multi-function panels. All multi function spoilers' panels deploy the same angle as a response to the speed brake lever position.

TRIM PANEL

CONTROL
PEDESTAL

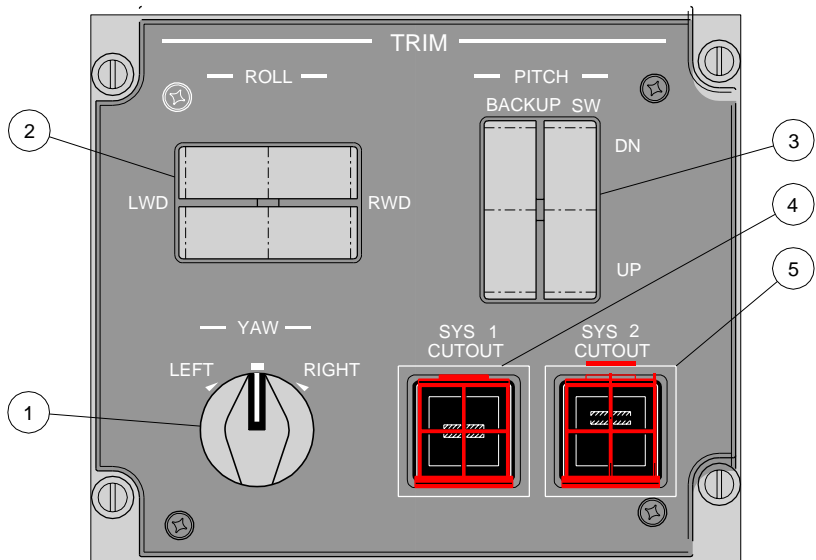
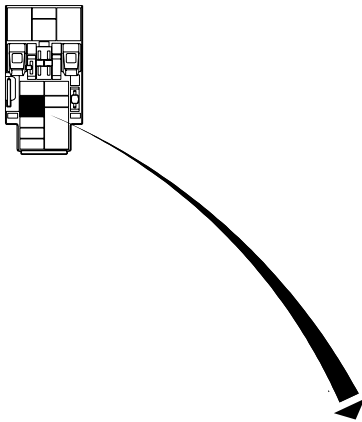

1 – YAW TRIM KNOB (SPRING-LOADED TO NEUTRAL)

- Actuates the yaw trim to left or right.

2 – ROLL TRIM SWITCH (SPRING-LOADED TO NEUTRAL)

- Actuates the roll trim to left or right.

3 – PITCH TRIM BACK-UP SWITCH (SPRING-LOADED TO NEUTRAL)

- Actuates the pitch trim through the back-up channel.
- Operation of the switch while the autopilot is engaged causes the autopilot to disengage.

4 – PITCH TRIM SYS 1 CUTOUT BUTTON (GUARDED)

PUSH IN: disables the HS-ACE channel 1.

PUSH OUT: enables the HS-ACE channel 1.

5 – PITCH TRIM SYS 2 CUTOUT BUTTON (GUARDED)

PUSH IN: disables the HS-ACE channel 2.

PUSH OUT: enables the HS-ACE channel 2.

FLIGHT CONTROL MODE PANEL

CONTROL
PEDESTAL

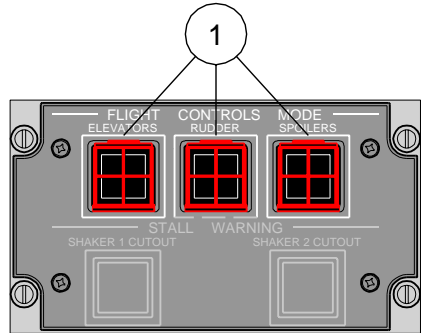
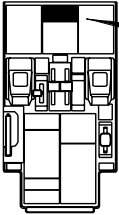

1 – FLIGHT CONTROL MODE BUTTON (GUARDED)

PUSH IN: turns the associated flight system into direct mode.

PUSH OUT: turns the associated flight system into normal mode.

DISCONNECT HANDLE

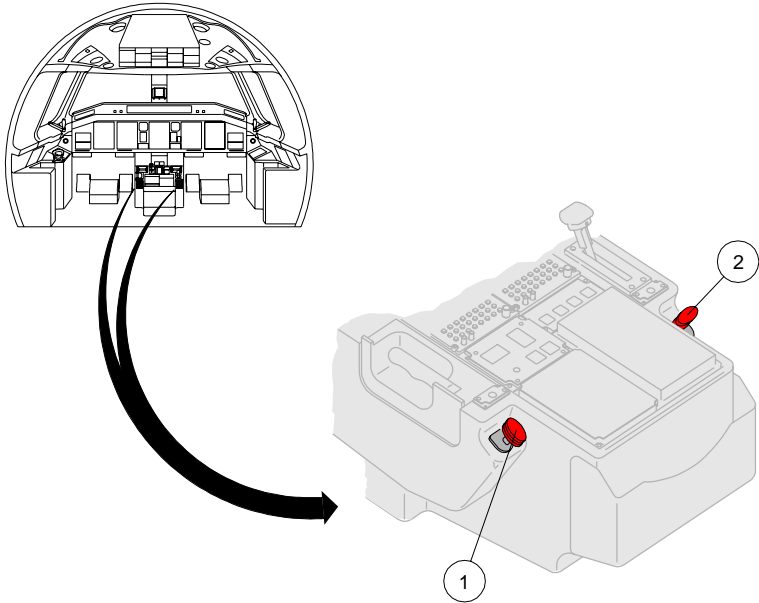

1 – ELEVATOR DISCONNECT HANDLE

PULL: disconnects the elevator control system.

2 – AILERON DISCONNECT HANDLE

PULL: disconnects the aileron control system.

FLIGHT CONTROLS SYNOPTIC PAGE ON MFD

The flight controls synoptic page provides a visual representation of the flight control system operation and parameters, and can be selected by the flight crew for viewing on either MFD.

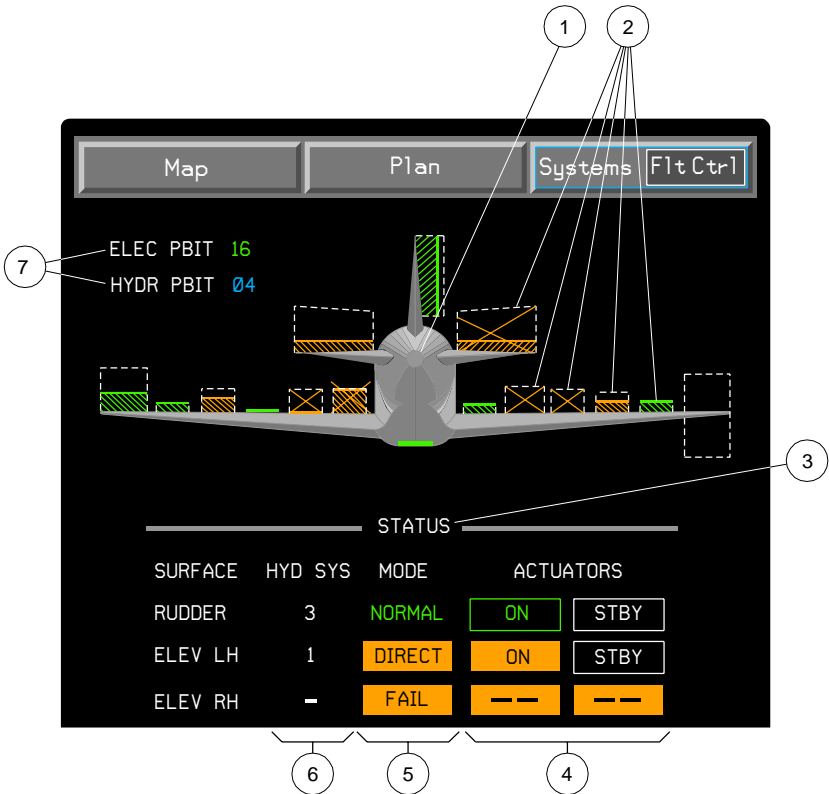

1 – AIRPLANE GRAPHIC

- A static display that shows the location of flight control surfaces, status of the flight control actuators and flight controls mode of operation.

2 – SURFACE POSITION STATUS

- **RETRACTED:** a green line aligned with the wings, elevator or rudder.
- **DEPLOYED:** a green line and the surface with green stripes. A white dashed box is shown only for surface position greater than 50% of its deflection.
- **FAILED RETRACTED:** an amber line, a white dashed box and an amber cross.
- **FAILED DEPLOYED:** white dashed box, surface with amber stripes and amber cross.
- **NOT AVAILABLE WITH NO FAIL INDICATION:** shows a white dashed box for surfaces with deflection in one direction (e.g. spoilers) and two white dashed box for surfaces with deflection in two directions (e.g. ailerons).
- **NOT AVAILABLE WITH FAILURE INDICATION:** shows a white dashed box and an amber cross for surfaces with deflection in one direction (e.g. spoilers) and two white dashed box and two amber crosses for surfaces with deflection in two directions (e.g. rudder).
- **DIRECT MODE:** shows the surface with amber stripes. A white dashed box is shown only for surface position greater than 50% of its maximum deflection.
As for flap zero the maximum surface deflection is about 50% of the full deflection, the white dashed box may not be shown, due to system tolerances.

3 – FLIGHT CONTROL SYSTEM STATUS ANNUNCIATIONS

- The status annunciations are shown in a table format for three surfaces. Three surfaces are listed in a column labeled SURFACE: RUDDER, ELEV LH, and ELEV RH.

4 – ACTUATOR STATUS ANNUNCIATION

- The rudder has two actuators, upper and lower. Each left and right elevator surfaces have two actuators, inboard and outboard.
- NORMAL/ACTIVE: a green ON annunciation inside a green rectangle box.
- NORMAL/STANDBY: a white STBY annunciation inside a white rectangle box.
- DIRECT/STANDBY: a white STBY annunciation inside a white rectangle box.
- DIRECT/ACTIVE: an ON annunciation presented in an amber rectangle box background.
- FAIL: a “—“ annunciation written in an amber rectangle box background.

5 – AXES MODE ANNUNCIATION

- Axes mode annunciations are shown for the rudder, the left and the right elevator. It is presented as NORMAL, DIRECT, FAIL or “-“, which represents the axes mode annunciation invalid.

6 – HYDRAULIC SYSTEM SOURCE ANNUNCIATION

- Hydraulic system source annunciations are shown for the rudder, the left and the right elevator. It is presented as 1, 2, 3 or “-“, which represents the source annunciation invalid.

7 – PBIT REMAINING TIME READOUT

- For airplanes Post-Mod. SB 190-31-0007 (Primus Epic Load 4.5) or an equivalent modification factory incorporated, a digital remaining time readout displays the hours until the electrical and hydraulic PBIT expire.
- If the value of the PBIT remaining time readout is higher or equal to 5, the numbers will be displayed in green, otherwise will be cyan. Invalid data will be represented by 2 dashes (“- -“) in amber.

EICAS INDICATIONS

SLAT/FLAP/SPEEDBRAKE INDICATION ON EICAS

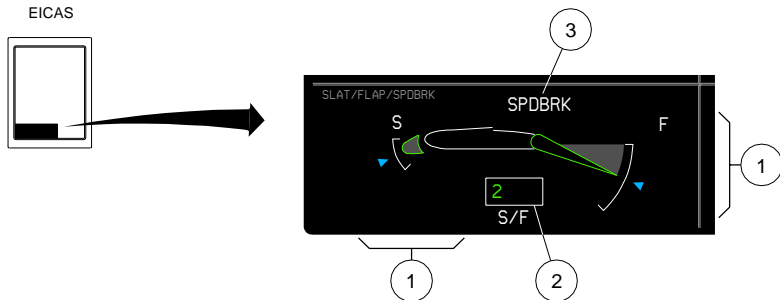

1 – SLAT/FLAP POSITION

- Displays the slat/flap position. If the information is invalid, the indication will be removed from the display.

GREEN: real-time surface position.

- The pointer shows the slat/flap commanded position along the scale and moves up the scale for decreasing values of slat/flap angle. The flap scale has tic marks at each end, representing positions at 0° and 35° while the slat scale has tic marks at each end, representing positions at 0° and 25°.

2 – SLAT/FLAP READOUT

- Displays the slat/flap surface position. If the information is invalid, the indication will be removed from the display.

GREEN DASHES: slat/flap in transit.

NOTE: In case of surface jamming, an additional box will be displayed in amber, as well as the readout.

3 – SPEEDBRAKE INDICATION

- Displays a white SPDBRK annunciation when the speed brakes are open.

AMBER BOXED: in case of failure.

NOTE: An OPEN and GREEN speedbrake position indication and a white GND SPLR annunciation display on EICAS after airplane touchdown and below 50 knots of ground speed.

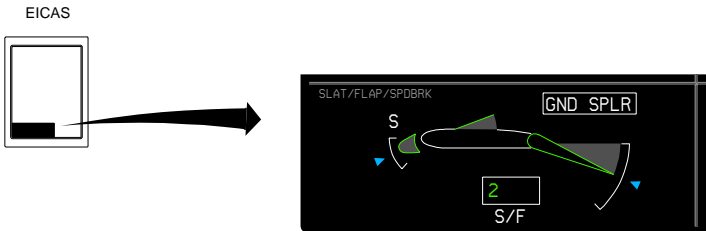

NOTE: For SLAT/FLAP/SPDBRK position 0 the legend and arrows will be removed from the display as presented below:

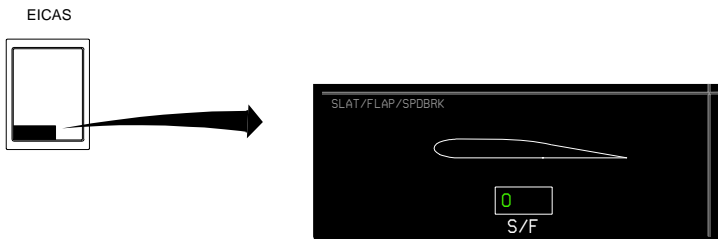

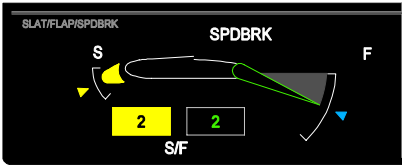

SLAT FAIL

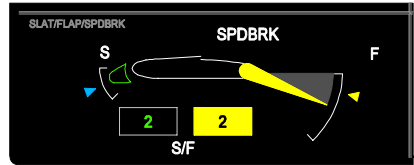

FLAP FAIL

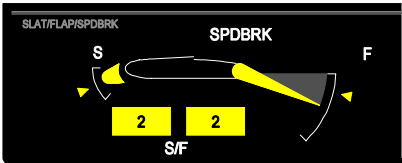

SLAT/ FLAP FAIL

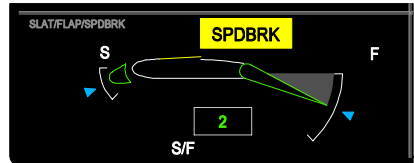

SPDBRK FAIL

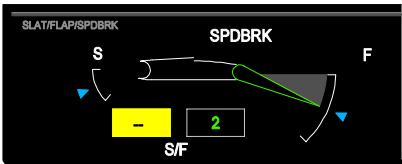

SLAT DATA INVALID OR UNAVAILABLE WHEN SLAT/ FLAP LEVER IS NOT IN ZERO POSITION

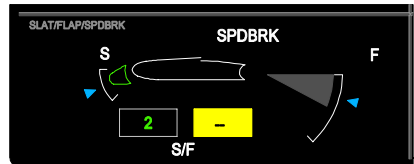

FLAP DATA INVALID OR UNAVAILABLE WHEN SLAT/ FLAP LEVER IS NOT IN ZERO POSITION

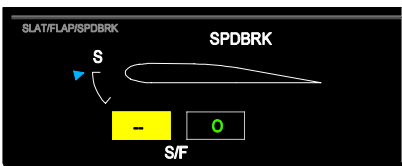

SLAT DATA INVALID OR UNAVAILABLE WHEN SLAT/ FLAP LEVER IS IN ZERO POSITION

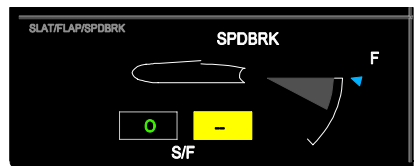

FLAP DATA INVALID OR UNAVAILABLE WHEN SLAT/ FLAP LEVER IS IN ZERO POSITION

OVERALL DISPLAY SITUATIONS

ROLL/PITCH/YAW TRIM INDICATION ON EICAS

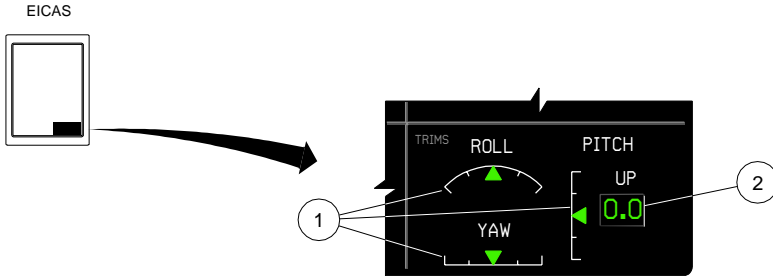

1 – ROLL/PITCH/YAW TRIM SCALE

- Trim position configuration is indicated through a solid green pointer in the scale.
- There are five tic marks displayed along the roll and yaw scale, positioned at -100% , -50% , 0% , 50% , 100% .
- There are five tic marks displayed along the pitch trim scale, positioned at 4° , 0.25° , -3.5° , -7.25° , and -11° . There is a green takeoff band on the scale extending from 2° to -4° , corresponding to the allowable pitch trim position for takeoff.

2 – PITCH TRIM DIGITAL READOUT

- Digital indication of the horizontal stabilizer trim position in tenth degrees
- An UP or DN indication displays above or below the readout according to the trim set.

FLY BY WIRE

Fly-by-wire is an electronic system designed to operate the flight controls replacing the control cables of a conventional airplane.

The EMBRAER 190 FBW system is composed of a set of six Actuator Control Electronics (ACEs) and four Flight Control Modules (FCMs):

- Two Primary-ACEs (P-ACE) installed in the forward electronics bay.
- Two Slat/Flap ACEs (SF-ACE) installed in the middle electronics bay.
- One Horizontal Stabilizer ACE (HS-ACE) and one P-ACE installed in the aft electronics bay.
- FCM 1 and 2 are located in the Modular Avionics Units # 1 (MAU 1).
- FCM 3 and 4 are located in the Modular Avionics Unit # 3 (MAU 3).

The three P-ACE units connect the control column directly to the respective control surface, providing direct analog control of the rudder and elevator surface actuators.

The two SF-ACE units control the slat and flaps and the HS-ACE unit controls the horizontal stabilizer.

The FCMs provide software-based assistance to the P-ACE and is required for normal-mode operation of the flight control system. The FCM units are connected to the P-ACE via the Controller Area Network Bus (CAN BUS), providing digital inputs to the P-ACE, which are combined with pilot inputs. This is used to augment pilot inputs for different airspeeds, and provides other high level functions such as Angle-of-attack (AOA) limiting to the P-ACE units.

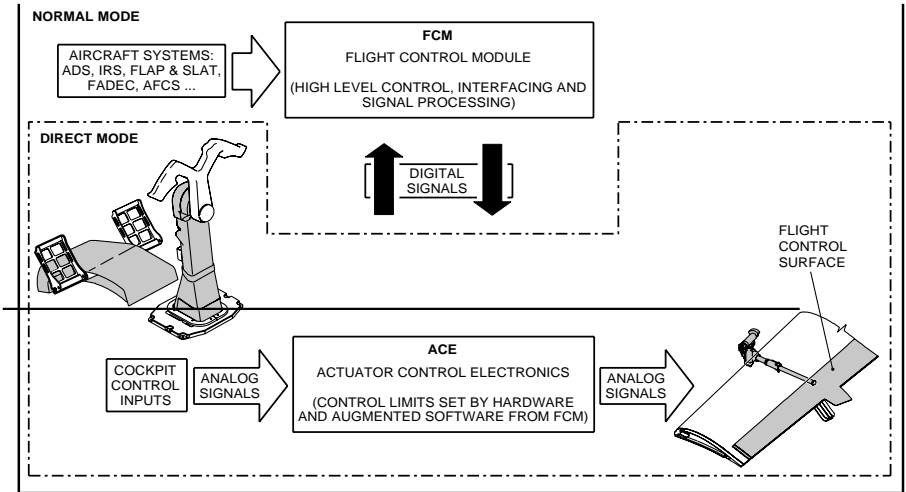

FLY-BY-WIRE SCHEMATIC

MODES OF OPERATION

The Flight Control System provide two basic modes of operation:

- **NORMAL MODE:** The Flight Control Mode (FCM) provides software based airspeed gain schedules and control limits to the P-ACE, as well as high level functions such as:
 - Elevator control laws scheduling with airspeed.
 - Auto-thrust compensation with elevator.
 - Angle-of-Attack (AOA) limiting with elevator offset.
 - Rudder airspeed gain scheduling and stroke limiting.
 - Yaw damper and turn coordination via AFCS.
 - Rudder ground/lift authority change.
 - Roll spoiler scheduling with airspeed and speedbrake deployment.
 - Configuration change compensation with Horizontal Stabilizer.
 - Mach Trim as a function of Mach number.
 - Configuration change compensation with Horizontal Stabilizer due to landing gear, flap/slat and speed brakes actuation.
- **DIRECT MODE:** The FCM is removed from the control loop (for instance, due to loss of airspeed data) and the control limits default to values set by hardware in the P-ACE.
 - Direct mode of operation is primarily the result of loss of data from all FCMs (no airspeed input) or; multiple ACE failures.
 - Operation is defaulted to fixed control laws configuration.
 - Control input provided by Captain and First Officer's sensors is sent directly to the surface.

Mode selection is automatic, when a channel failure is detected or manual, by using a “Mode Select” switch on the Flight Control Panel.

The “Mode Selection” switch toggles the Normal Channel of the active P-ACE to the Direct Channel of the standby P-ACE and continues as shown:

Pilot always has supreme control authority of the airplane since the FCMs cannot override a pilot input.

FCM, P-ACE AND AIRPLANE LEVEL COMMUNICATION

The Controller Area Network BUS (CAN BUS) is the communication link between the FCMs and the P-ACE units while the Avionics Standard Communication Bus (ASCB) provides data exchange between all FCMs, and with other components of the avionic system. The following systems provide data to the flight control system:

- Smart probes and the Air Data Application (ADA) modules provide air data for various airspeed augmentation commands.
- IRS provides aircraft attitude and accelerations to the FCMs used for AOA limiting function computation.
- The Proximity Sensor Electronic Module (PSEM) provides Weight-On-Wheels (WOW) and ground spoiler position data to the FCMs.
- Brake Control Modules (BCM) provide wheel speed signals used for ground spoiler deployment.
- The FADEC provide Thrust Lever Angle (TLA) to the FCMs used for elevator thrust compensation, and the Automatic Flight Control System (AFCS) provides autopilot commands.
- Data is shared for the EICAS to display warnings, cautions, advisory and system status and also provided to the central maintenance computer (CMC) for system diagnostics.

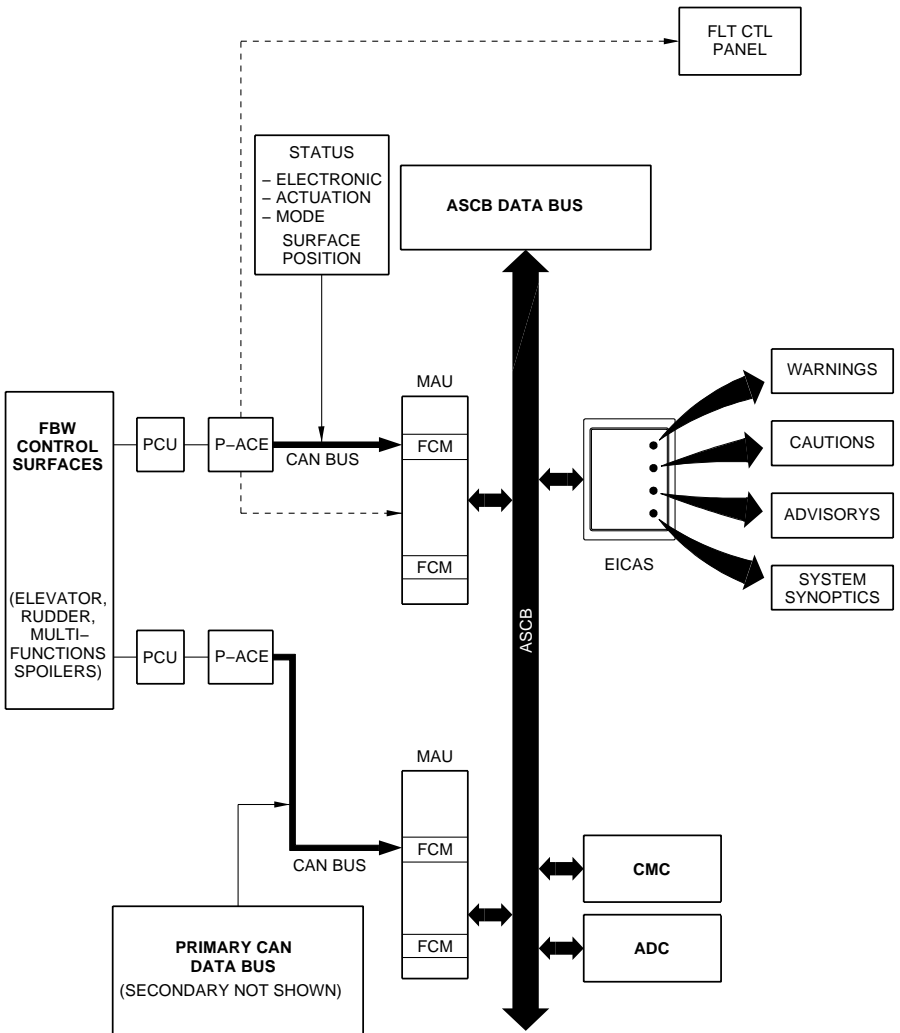

AIRPLANE COMMUNICATION INTERFACE

POWER UP BUILT IN TEST (PBIT)

The Power Up Built in Test (PBIT) reduces the flight control system exposition to latent faults, ensuring that the system components remain capable of executing their functions.

The PBIT expires after 20 hours (elapsed time) since the last successful PBIT and in this case the FLT CTRL BIT EXPIRED EICAS CAUTION message is displayed. These EICAS CAUTION message is related to the Electrical PBIT and Hydraulic PBIT. The message remains on EICAS until a new Electrical and Hydraulic PBIT is successful ran.

No action is required if the PBIT expires in-flight, as the EICAS CAUTION message will only be displayed after landing.

ELECTRICAL POWER UP BUILT IN TEST

The Electrical PBIT provides detection of out-of-tolerance conditions and failures in the FCMs, P-ACEs and SF-ACEs.

The Electrical PBIT is automatically performed during power up after the airplane is powered by any AC source and takes approximately 3 minutes to complete. In this point if the FLT CTRL BIT EXPIRED message is presented, the hydraulic built in test must be performed.

For airplanes Post-Mod. SB 190-31-0007 (Primus Epic Load 4.5) or an equivalent modification factory incorporated, FLT CTRL TEST IN PROG Status message is presented while electrical PBIT is in progress.

If the airplane is already powered up, the crew may check the PBIT REMAINING TIME READOUT before starting the taxing out procedure. Hence, if the remaining time is sufficient for the taxing and taking off, the crew may elect to reset the PBIT on the next flight.

The Electrical PBIT will be interrupted if any electric hydraulic pump is running or if the FCP switches are cycled or if AC power is interrupted while the test is running.

HYDRAULIC POWER UP BUILT IN TEST

The Hydraulic PBIT provides functional test of the flight control actuators.

The Hydraulic PBIT is performed automatically, only on the ground, when the flight controls are not moved for one minute and all the three hydraulic systems are pressurized. The test takes one minute to complete.

The Hydraulic PBIT will be interrupted if any flight control surface is moved while the test is running.

FLY BY WIRE (FBW) BACKUP BATTERY

In case of an extremely improbable failure that would render complete loss of normal and emergency electrical power to the FBW, the backup power system, with no pilot intervention, keeps the appropriate number of elevator and rudder actuators operating for at least 15 minutes. Besides that, there is no dedicated message to indicate the failure of this system; therefore there is no flight crew compensatory action if this happens.

A dedicated and independent backup electrical power system is provided for some elevators and rudder Actuator Control Electronics (ACEs) that are considered essential for airplane controllability even in an utmost case of total loss of the normal and emergency electrical power sources.

This backup system is comprised by a dedicated battery, distribution bus and circuit breakers.

The backup battery, charged by the DC ESS 3 bus during normal operation, consists of sealed lead acid cells with built-in-test (BIT) capability and internal heater that guarantees the minimum battery temperature.

Although the battery is connected to the airplane buses, the use of an internal rectifier keeps it from powering back the buses, assuring isolation in case of failure in the main electrical power system.

PITCH CONTROL

Pitch axis control is by means of electro-hydraulic commanded elevators and an electro-mechanical horizontal stabilizer.

ELEVATOR CONTROL SYSTEM

Pilot's inputs to the elevators are through the forward and after movement of the cockpit control columns. Also, the elevators can be automatically controlled through the FCM via autopilot.

A total of four P-ACE channels are used to independently control each of the four PCUs, providing the analog elevator control functions implemented in the P-ACE units.

Four independent FCM units, located in the MAU 1 and 3, provide high-level system augmentation to the P-ACE units, such as gain scheduling as a function of airspeed, elevator thrust compensation and AOA limiting.

The hydraulic systems responsible for actuating the actuators are:

- Hydraulic System 1: left outboard actuator.
- Hydraulic System 2: left & right inboard actuators.
- Hydraulic System 3: right outboard actuator.

Since the actuators on each surface operate on active/standby mode, the P-ACE automatically alternates the active actuator every time the elevator system is powered up. The loss of hydraulic supply forces the standby PCU to become active.

If a jam in one of the elevator actuator is detected, the respective elevator surface will remain fixed at the position where the jam occurred. The pilot will be able to control the airplane using the remaining elevator.

With the elevator control system operating in normal mode, the elevator moves according to gain scheduling as a function of airspeed, reducing elevator movement with increasing airspeeds. In the event of loss of airspeed information, the FCM is removed from the control loop, and the associated P-ACE reverts to direct mode. FCM functions like elevator thrust compensator and AOA limiting are then no longer available.

A dedicated button on the Flight Control Mode panel provides the capability to the pilots to reset the elevator system to Normal Mode in case of the system defaulting to Direct Mode, or to manually default the elevator system to Direct Mode in case of wrong gain computed by the FCMs being transmitted to the P-ACEs.

When the flight control panel elevator button is pushed in, it commands all four elevators channel to change from Normal to Direct mode. In addition, pushing the button also results in the active elevator channels transitioning to the standby state, and the channels that were previously in standby would become active. This feature is also included to allow the system to transition away from the present controlling channels.

When the flight control panel elevator button is pushed out, the system recovers the Normal Mode.

The Elevator Thrust Compensation Function (ETC) helps to reduce the pilot workload by applying elevator commands to reduce the pitching moment produced by increasing or decreasing engine thrust. The ETC function is computed in the FCM as a function of N1, mach and pressure altitude. Elevator command is limited to plus or minus 5 degrees, and is applied proportional to the amount of engine thrust above or below the reference thrust setting.

If one or more sensors required to perform the ETC function fail, the function is no longer available and the respective message will be displayed on the EICAS.

TAIL STRIKE AVOIDANCE (TSA)

Tail Strike Avoidance (TSA) function is a fly-by-wire feature designed to avoid tail strikes occurrences during takeoffs and landings.

TSA function controls airplane pitch angle by reducing control column authority in the nose up direction. The maximum pitch angle that can be achieved by the airplane is a function of height above ground level (HAGL), measured at the main landing gear wheel. HAGL calculation depends on:

- Landing: HAGL calculated via two radio altimeters.
- Takeoff: estimated HAGL by means of the vertical speed.

The authority of TSA function depends on whether in takeoff or landing configuration. Go around is considered a landing configuration mode.

In case of TSA function engagement during takeoff, the maximum pitch down elevator deflection in order to correct airplane attitude by reducing its pitch rate is limited to 8° . In case of a negative pitch rate, the maximum pitch up elevator deflection is limited to 0° . For TSA engagement during landing situations, the pitch down authority is also limited to 8° of elevator deflection, while pitch up is limited to Normal Mode commands generated by other fly-by-wire functionalities.

TSA commands are limited to only 8° of elevator deflection.

NOTE: In case of exceedance of the angle of attack threshold defined by the AOA limiter due to an TSA elevator command, the FBW system switches to AOA limiter operation, smoothly transitioning to pitch angle control to angle of attack control over 2 seconds. The TSA function and the AOA limiter function never operate simultaneously and AOA limiter has priority over TSA.

TAKEOFF AND LANDING OPERATION

TSA operation is limited up to 20 ft for takeoffs and 70 ft and below for landings. Also, there is no TSA operation for landing flap configuration other than 5 or 6.

For GO AROUND scenarios, TSA operates as if it were in takeoff mode but using radio altimeter altitudes rather than estimated altitude as the source of HAGL computation.

ARTIFICIAL FEEL UNITS (AFU)

With no mechanical connection between the control column and the elevator surfaces, two independent feel units provide artificial feel and centering to the control columns, which increase as a function of control column displacement.

The feel units consist of a preloaded spring, which returns the columns to the neutral position. Hence there is one feel unit attached to each torque tube, in case of separation of the control column commands, the feel system is still active for the non-jammed column.

With the columns disconnected or with a single AFU disconnected, the feel loads on the column are reduced to one half of the normal loads

DISCONNECT MECHANISM (JAMMED COLUMN)

A disconnect mechanism is provided in order to allow separation of the First Officer and Captain's control column. In the event of a jam in one of the control columns, the disconnect mechanism can be actuated by pilots through the disconnect handle in the cockpit.

Following a disconnection the pilot of the non-jammed side retains pitch control by means of the on-side elevator. The system will remain disconnected for the remainder of the flight and ground maintenance is required to reset the disconnect unit.

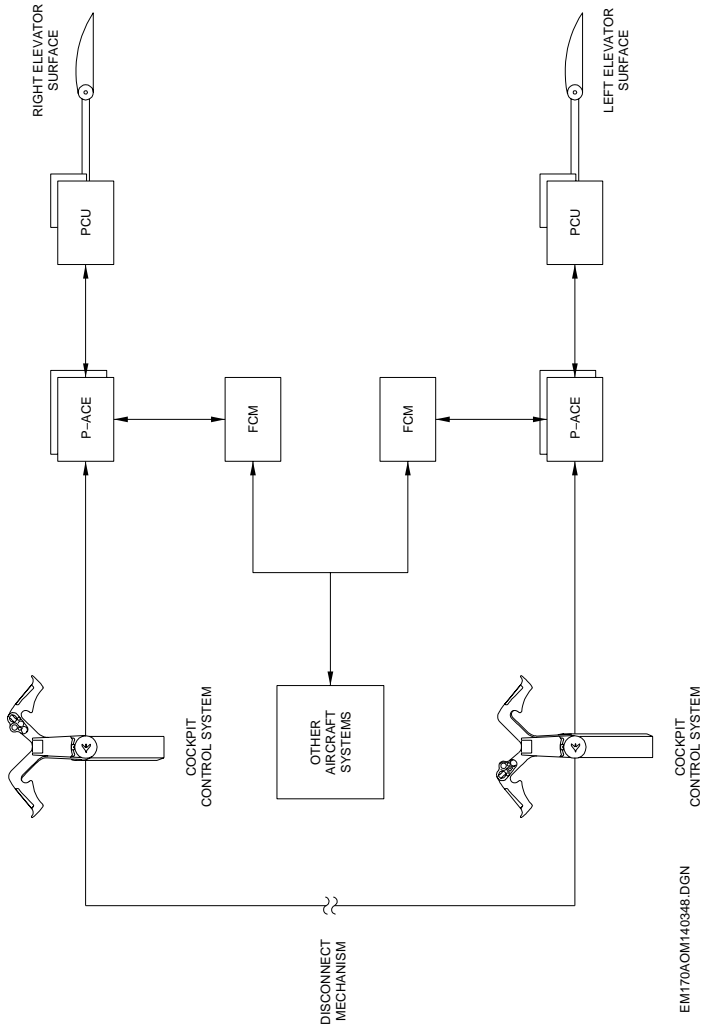

ELEVATOR SYSTEM SCHEMATIC

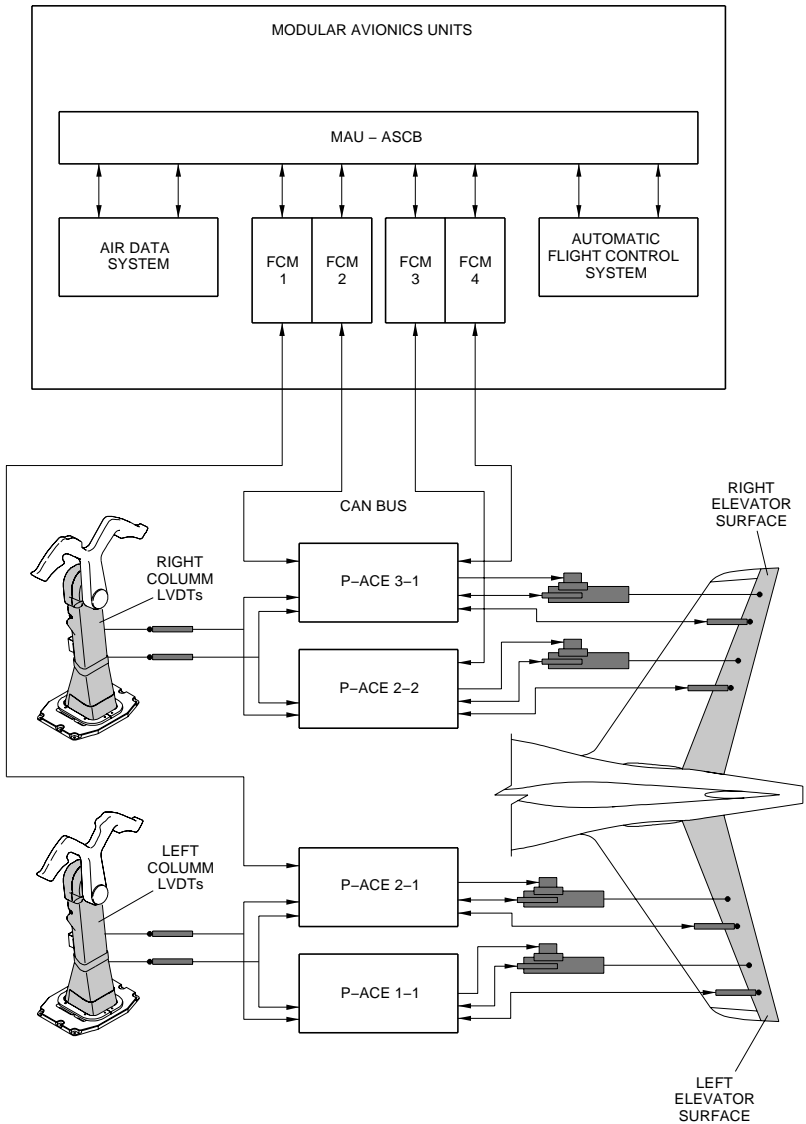

ELEVATOR SYSTEM INTERFACE

HORIZONTAL STABILIZER CONTROL SYSTEM

Control of the horizontal stabilizer is by means of an electromechanical system commanded by:

- Manual selection of the Captain or First Officer's wheel main trim switches or pedestal mounted backup trim switches which directly controls an electrical servo motor coupled to the Horizontal Stabilizer Actuator (HSA).
- Flight Controls Module (FCM) for autopilot trim and speed brake auto trim in order to actuate the electrical servomotor coupled to the Horizontal Stabilizer Actuator (HSA).

Horizontal Stabilizer Actuator Control Electronics (HS-ACE) and one Horizontal Stabilizer Actuator (HSA) are used to move the control surface.

The HSA is a single electrical-mechanical actuator. Two DC motors drive the actuator in an active/standby configuration. Stabilizer position is provided to the HS-ACE and is used for monitoring and EICAS indication.

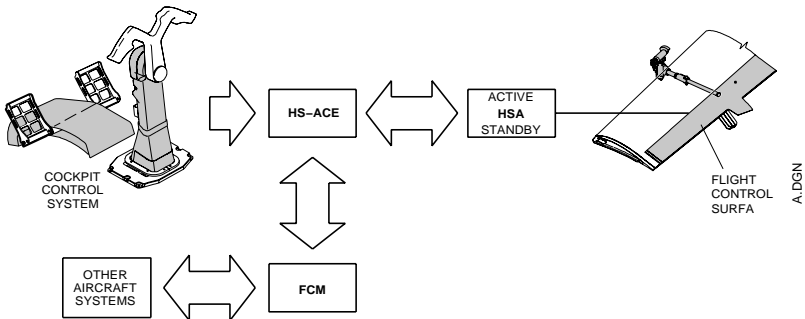

STABILIZER TRIM

MANUAL TRIM

The manual trim is achieved through switches installed on the control columns and standby switch located on the main pedestal. Signal from either the control columns switches or the main pedestal switch controls the electric trim motor.

The HS-ACE responds to all trim commands with the following priority:

1. Backup switches.
2. Captain.
3. First Officer.
4. FCM (auto-trim) commands.

In order to avoid a possible pitch trim runaway condition, manual pilot trim commands are limited to 3 seconds. In case of stick shaker activation, the HS-ACE is prevented from responding to any pitch trim commands by a stick shaker signal from the AFCS.

The backup trim switches and the control wheel trim switches are dual split switches, which have a 7 second time limitation when actuated separately. If only one half of the switch is actuated for more than 7 seconds, this switch is automatically deactivated.

In the event of an electrical emergency, only the HS-ACE channel 2 is operational at low rate. A loss of airspeed data from the FCM also results in low rate operation of the horizontal stabilizer, providing structural protection of the surface.

AUTOPILOT TRIM

The autopilot can directly operate the electric trim motor when the autopilot is engaged. If the autopilot trim function is inoperative, the autopilot cannot be engaged. If this function is lost with autopilot operations, the autopilot will be disengaged.

Autopilot trim function will be active only if:

- Autopilot is engaged.
- Configuration trim is operational.
- Manual electric trim is not active.
- On-side autopilot channel is priority.

NOTE: In case of an electrical failure, followed by RAT deployment, the trim function will work at half speed operation, for either manual trim or autopilot trim.

MACH TRIM

Automatic Mach trim compensate pitch down tendency due to aft change in location of aerodynamic center for increasing Mach number.

For further information about Mach trim operation refer to chapter 14-03 Automatic Flight.

ROLL CONTROL

Roll control is provided simultaneously by the ailerons and the multifunction spoilers.

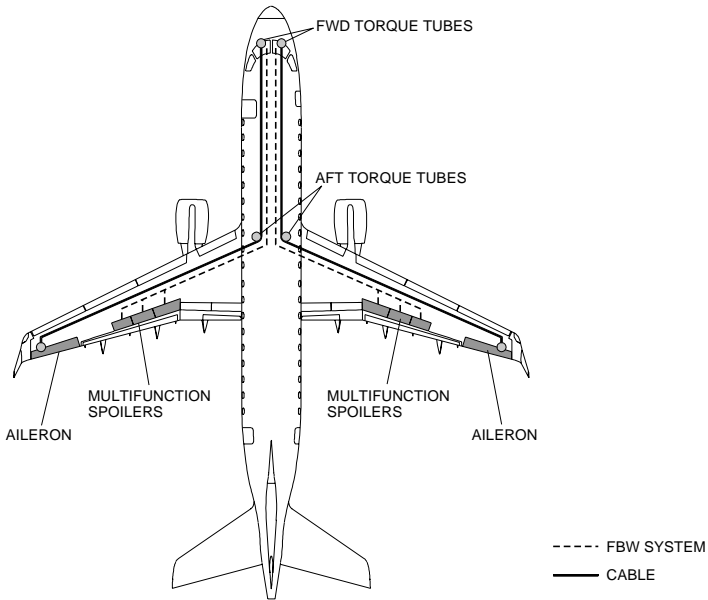

AILERON CONTROL SYSTEM

Aileron control is accomplished through a conventional cable system, which transmits pilot control wheel inputs to two hydro-mechanical actuators for each aileron.

The hydraulic systems responsible for actuating the actuators are:

- Hydraulic System 2: left & right inboard PCU.
- Hydraulic System 3: left & right outboard PCU.

Captain and First Officer aileron control system are connected via a disconnect mechanism. In the event of a jam, the disconnect mechanism can be actuated by the pilots by means of the disconnect handle in the cockpit. Following a disconnect, half of the system remains operational. If the jam occurs on the First Officer's half of the system, the Captain retains control of the left aileron with normal artificial feel.

If the jam occurs on the Captain's side, the First Officer remains in command of the right aileron without artificial feel and roll trim since the feel mechanism is attached to the pilot's half of the system. Only one pair of multifunction spoilers will remain available after the disconnection

Following a disconnect, the system remains separated for the remainder of the flight. Maintenance action is required to reconnect the disconnect device.

In the event of a disconnect of one aileron PCU from the surface or wing structure, the other PCU attached to the surface will operate normally, but the force authority will be halved. Hence the aileron PCUs normally share air-loads during flight, if the FCM detects a difference in load sharing from the actuators, a message will be displayed on the EICAS.

MULTIFUNCTION SPOILER CONTROL SYSTEM

The multifunction spoiler control system consists of 6 panels numbered from inboard to outboard as:

- L3, L4, L5 (left wing) and
- R3, R4, R5 (right wing).

The roll spoiler function drives all six multifunction spoiler panel deployment asymmetrically as a function of control wheel position.

As airspeed increases, less spoiler surface deflection is required and the spoiler system will limit the deployment of the surfaces for roll control.

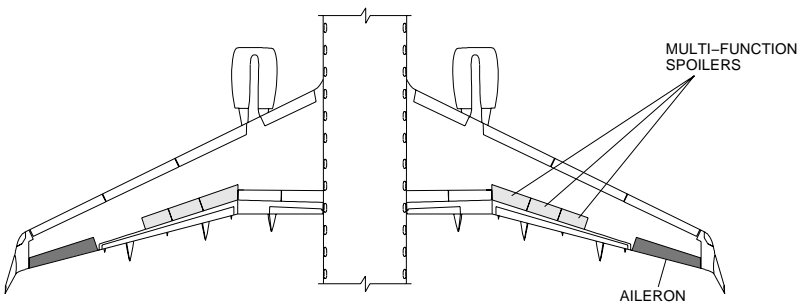

ROLL CONTROL SURFACES POSITION

In the event of a jam, the control wheel and the aileron on the jammed half of the system will be locked at the current position. The other half of the system can be separated from the jammed side through the aileron disconnect handle located at the control pedestal. In this case, the Captain controls the outboard spoilers, while the First Officer controls the middle spoilers. With disconnection due to jamming, the inboard spoilers become disabled.

ROLL TRIM

The aileron control system is manually trimmed by using the roll trim switch on the trim control panel, located in the cockpit on the center pedestal. The trim system is operated via the roll trim switch on the trim control panel, commanding the actuator to move, and repositioning neutral feel position of the aileron system.

The actuator is equipped with a timer, limiting a single trim command to three seconds. A quick disconnect switch, located on the control wheels, disables the roll trim actuator by interrupting DC power to the trim motor, as long as the switch remain depressed.

YAW CONTROL

Yaw control is performed by means of an electronic control system that commands electrohydraulic actuators of the rudders.

RUDDER CONTROL SYSTEM

The rudder control system is controlled either by the pilots, FCM high-level functions and additionally, in airplanes equipped with Autoland, the Autopilot.

The rudder control system moves a single rudder surface attached to the vertical stabilizer. Two actuators, or PCUs, electrically commanded and hydraulically powered, are connected to the rudder control surface, receiving signals from the rudder control's Fly By Wire system (FBW).

Either the upper or the lower rudder actuator can control the rudder surface. The Captain commands only the upper actuator and the First Officer commands only the lower actuator.

Two independent P-ACE modules drive the upper and lower PCU, providing the analog rudder control functions implemented in the P-ACE hardware, such as pedal shaping to vary the pedal-to-surface gearing as a function of pilots input.

Four independent FCM units, located in MAU 1 and 3, provide high-level system augmentation on the P-ACE units, such as yaw damping, turn coordination, as well as gain scheduling as a function of airspeed.

The rudder actuators operate in an active/standby configuration, hence the P-ACEs alternate between the active PCU every time the rudder system is powered-up.

The hydraulic systems responsible for actuating the actuators are:

Hydraulic System 1: upper actuator, or PCU.

Hydraulic System 3: lower actuator, or PCU.

In the normal mode, the FCMs add further high-level functions to the pilot pedal inputs. With increasing airspeed, rudder gain is reduce by the FCM in order to compensate for the increase in rudder effectiveness, and providing structural protection to the rudder surface.

A dedicated button on the Flight Control Mode panel provides the capability to the pilots to reset the rudder system to Normal Mode in case of the system defaulting to Direct Mode, or to manually default the rudder system to Direct Mode in case of wrong gain computed by the FCMs being transmitted to the P-ACEs.

When the flight control panel rudder button is pushed in, it commands both rudder channels to change from Normal to Direct mode. In addition, pushing the button also results in the active rudder channels transitioning to the standby state, and the channels that were previously in standby would become active. This feature is also included to allow the system to transition away from the present controlling channels.

When the flight control panel rudder button is pushed out, the system recovers the Normal Mode.

The two pedals assemblies (Captain and First Officer) are connected by an interconnect rod, in such a way that the movement made by the pilot flying (PF) assembly will be transmitted to the pilot not flying.

In the event of a jam in the Captain's rudder pedal assemblies, the rudder remains active and will be actuated by high-level functions (yaw dumping and turn coordination). In case of a jammed PCU actuator the rudder will be hydraulically locked at the current position. Aircraft control will be established through the ailerons and roll spoilers.

RUDDER TRIM SYSTEM

Rudder trim function is limited to three seconds. If further displacement of the trim system is required the command must be released and reapplied. Position indication of the trim actuator is provided on the EICAS.

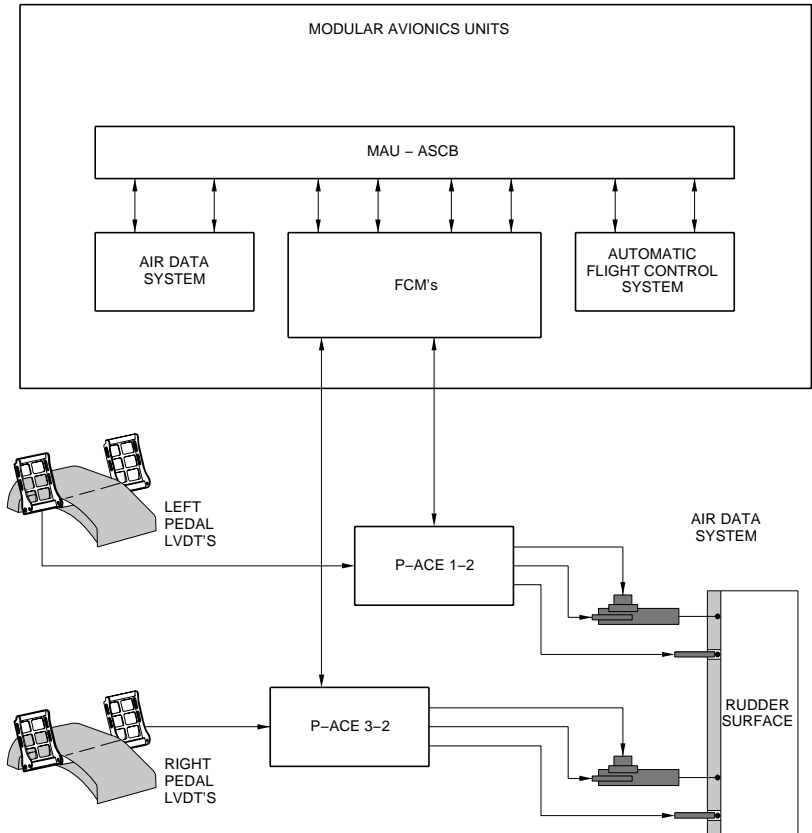

RUDDER SYSTEM INTERFACE

SLAT/FLAP SYSTEM

The high lift control system consists of flaps and slats.

The slat system controls eight slat surfaces on the leading edge of the wing (four per wing) and the flap system controls four double slotted flap surfaces on the trailing edge (two per wing).

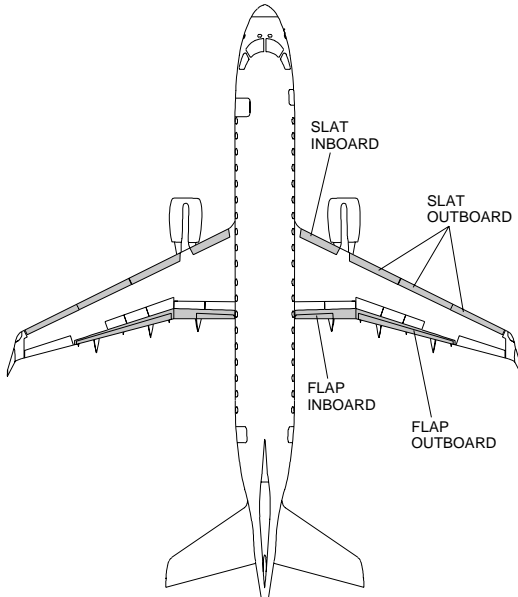

SLAT/FLAP PANEL LOCATION

Surface position commands are given to the Slat/Flap-ACE (SF-ACE) via a Slat/Flap control lever installed on the center pedestal in the cockpit. Each SF-ACE is a dual channel unit, with one channel for flap control and one channel for slat control.

There are seven slat/flap control lever positions. Slat and flap motion is sequenced such that slats extend first and flap retracts first when the motion command requires both surfaces to move. The system uses electrical power to move the surfaces.

Deployment of both slats and flaps surfaces is commanded by two SF-ACEs and electrically operated using Power Driver Units (PDUs).

A total of four flap actuators per side provide the actuation force to extend and retract the flap panels mounted on the trailing edge of each wing. The double-slotted flap consists of a main flap panel and an aft flap panel for both inboard and outboard flaps.

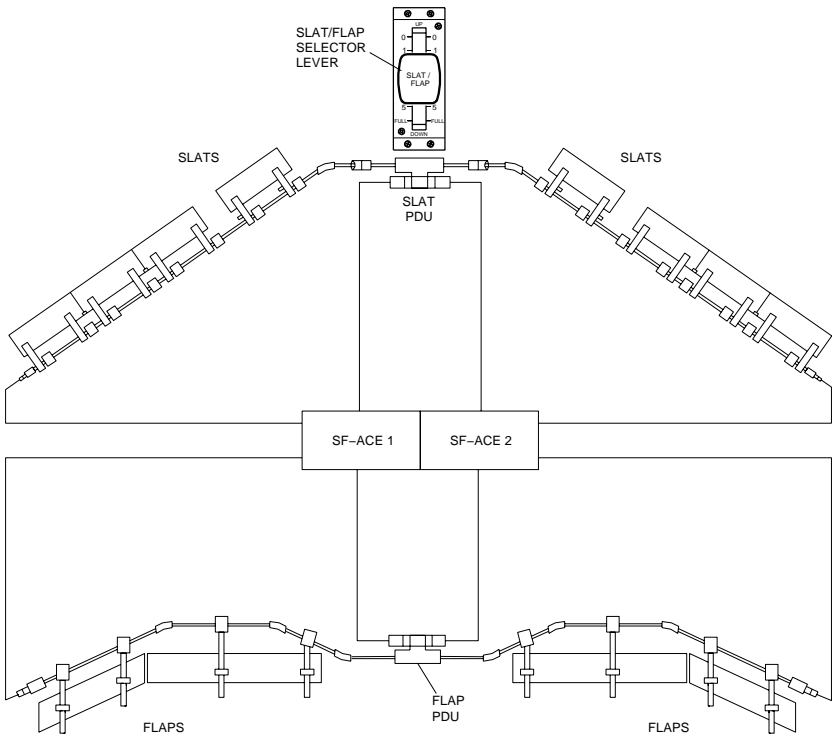

SLAT/FLAP SYSTEM SCHEMATIC

SLAT/FLAP PROTECTION LOGIC

SKEW PROTECTION

Electronic skew sensors monitor differential movement between neighboring panels of flap (slat). If differential movement of a panel exceeds acceptable limits, the SF-ACES shuts down the flap (slat) system and the FLAP (SLAT) FAIL message displays on EICAS.

The SLAT-FLAP LEVER DISAG may appear, as the affected surface has not reached the position selected on the Slat/Flap Lever. The affected surface is inoperative for the remainder of the flight whereas the non-affected surface operates normally (i.e., in case of FLAP FAIL the Slats operates normally and vice-versa).

STRIKE PROTECTION

The SF-ACE monitors PDU load and if an excessive load is detected it stops the electrical power to the respective PDU for further movement to the selected direction. The FLAP (SLAT) FAIL message displays and the SLAT-FLAP LEVER DISAG also displays, as the affected surface has not reached the selected position.

In such cases, the affected surface can be commanded in the opposite direction (i.e., for FLAP FAIL during retraction, the Flap can be commanded for extension and vice-versa).

When the strike protection actuates, the affected surface accepts to be commanded in both directions if it is returned to the previously selected position. After three unsuccessful attempts to select a position, the strike protection cuts the PDU power for both directions.

SLAT/FLAP SYSTEM INTERLOCKS

The SF-ACE has two independent channels that are powered by different electrical power sources. If the Ram Air Turbine (RAT) is the only source of electric power, the flap and slat operate in half speed, as only one channel remains available. Additionally, when RAT is the only source of electrical power, the SF-ACE prevents deployment of slats and flaps beyond position three to assure adequate airspeed for the RAT.

In case of a Flap or Slat failure, when the affected surface is deenergized, the SF-ACE still commands the non-affected surface upon S/F Lever movement. That permits to improve the landing performance even in the event of failure by selecting a more appropriate position of the non-affected surface. However, there are some combinations of Slat and Flap that are automatically protected by the system, as they would induce poor airplane controllability. Thus, the SF-ACE does not command the Flap beyond 10° (S/F Lever on position 2) with the Slat below 15°. In this failure scenario, if the S/F Lever is commanded beyond the position 2, the SF-ACE limits the Flap deflection to 10° and the SLAT-FLAP LEVER DISAG message displays.

SPOILER SYSTEM

The spoiler control system consists of ten spoiler panels numbered inboard to outboard as:

- L1, L2, L3, L4, L5 (left wing) and
- R1, R2, R3, R4, R5 (right wing).

Panels L3, R3, L4, R4, L5 and R5 are called multifunction spoilers and have three modes of operation:

- **Roll Control:** deployed asymmetrically for roll augmentation as commanded by the pilots control wheel. Displacement angle is proportional to control wheel displacement.
- **Speed Brakes:** deployed symmetrically during flight by speed brake handle to increase aerodynamic drag to reduce airspeed or increase rate of descent. Panel displacement is proportional to speed brake handle position.
- **Ground Spoilers:** deployed symmetrically during landing roll to increase wheel braking efficiency and aerodynamic drag to reduce the stopping distance. Panels are fully and automatically extended when ground spoiler deployment conditions are met.

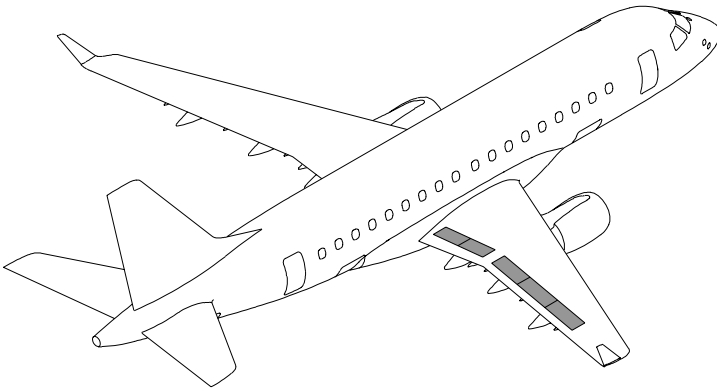

SPOILERS LOCATION

The hydraulic systems responsible for actuating the multi function PCUs are:

- Hydraulic System 1: left and right inboard and middle PCUs (L3, R3, L4, R4).
- Hydraulic System 2: left and right outboard PCUs (L5, R5).

The hydraulic systems responsible for actuating the dedicated ground spoilers PCUs are:

- Hydraulic System 1: left and right outboard PCUs (R2, L2).
- Hydraulic System 2: left and right inboard PCUs (R1, L1).

GROUND OPERATION

The spoiler control system provides automatic ground spoiler deployment to increase wheel-braking efficiency reducing the lift generated by each wing and to reduce the stopping distance producing aerodynamic drag.

During ground operation, all spoiler panels function as ground spoilers and are commanded to the fully extended or fully retracted positions.

The ground spoiler function drives all ten spoiler's panels to the limit deflection of the actuators.

MULTI-FUNCTION AND GROUND SPOILERS DEPLOYMENT

After touchdown the FCM will command all multifunction spoiler surfaces to the 40 degrees extended position and the ground spoiler surfaces to 60 degrees when the following conditions are simultaneously met:

- Weight on wheels on ground.
- Wheel speed is above 45 kts or airspeed is above 60 KIAS.
- Thrust Lever Angle (TLA) below 26 degrees

Following rollout, the spoilers will automatically retract when wheel speed is below 45 kts for at least 5 seconds. If the throttles are moved beyond 35 degrees (TLA) after landing, the spoiler panels will automatically retract.

NOTE: In the direct mode, ground spoilers are not available.

IN-FLIGHT OPERATION

ROLL SPOILERS

The roll spoiler function drives the multifunction spoiler panels asymmetrically as a function of control wheel position.

In normal mode, the roll spoilers are also gain scheduled as a function of airspeed. A roll spoiler augmentation command, computed in the FCM, is added to the normal pilot input in order to modify the roll inputs for changes in airspeed results or different flap settings.

In case of loss of airspeed data, the respective FCM is removed from the control loop, and the system reverts to direct mode. A fixed gain is then applied to the respective roll spoiler system for the entire flight, independent of airspeed or flap setting.

SPEED BRAKES

When actuating as speed brakes, the spoiler control system deploys all six multi function spoiler panels symmetrically up to the in-flight limit of 30 degrees following speed brake handle position.

If extended during approach, the speed brakes will automatically retract upon selection of slat/flap 2 or above.

Speed brakes will not be deployed if airspeed is below 180 KIAS, and will also automatically retract if airspeed decreases below this threshold.

In order to prevent inadvertent operation during a go-around maneuver the speed brakes will automatically retract anytime the thrust levers are advanced beyond Thrust Lever Angle (TLA) 70 degrees.

In the event of a disagreement of the speed brake handle position with actual surface position, the EICAS advisory message SPDBRK LEVER DISAG is displayed on the EICAS.

NOTE: In the direct mode, speed brakes are not available.

EICAS MESSAGES

TYPE	MESSAGE	MEANING
WARNING	ELEV (RUDDER) (SPOILER) NML MODE FAIL	Normal mode of the associated system is no longer operative.
	GROUND SPOILERS FAIL	One of the ground spoiler surfaces has extended inadvertently or has failed to extend when commanded.
CAUTION	AOA LIMIT FAIL	Stall protection function has failed.
	ELEV THR COMP FAIL	One or more sensors required to perform Elevator Thrust Compensation function have failed and the function is no longer available.
	ELEVATOR FAULT	Left and right elevator control system has reverted to direct mode.
	ELEVATOR LH (RH) FAIL	Left (right) elevator control system is no longer available.
	FLAP FAIL	Both flaps electronic control channels are inoperative and the flaps system is no longer available or there is a jam in the mechanical portion that precludes the flaps from moving.
	FLT CTRL BIT EXPIRED	20 hours or more has passed since the last time PBIT was activated.
FLT CTRL NO DISPATCH	One of the components associated with the flight control system has failed to a No-Go condition.	

TYPE	MESSAGE	MEANING
CAUTION	PITCH TRIM FAIL	Pitch trim function is no longer available.
	RUDDER FAIL	Active and standby rudder channels have failed or rudder has jammed.
	RUDDER FAULT	Indicates that the rudder control system has reverted to direct mode.
	RUDDER LIMITER FAIL	Indicates that rudder ground authority is retained after take-off.
	SLAT FAIL	Both slats electronic control channels are inoperative and the slats system is no longer available or there is a jam in the mechanical portion that precludes the slats from moving.
	SLAT-FLAP LEVER DISAG	Flaps were commanded above V_{FE} .
	SPOILER FAULT	Airspeed gain scheduling has failed in one or more pairs of multifunction spoilers, and the system(s) has defaulted to a fixed gain.
	STAB LOCK FAULT	The mechanical device, which locks the horizontal stabilizer, has failed. Direct mode is not allowed.

TYPE	MESSAGE	MEANING
ADVISORY	AILERON LH (RH) FAIL	Indicates that the left (right) aileron is no longer available or there is a mechanical disconnection in the left (right) aileron surface.
	AUTO CONFIG TRIM FAIL	Pitch Trim Auto Configuration function is inoperative.
	FLAP LO RATE	One of the flaps electronic control channels is inoperative and the flap system is still available but running at low speed.
	FLT CTRL FAULT	One of the components associated with the flight control system has failed.
	PITCH CONTROL DISC	Control columns are disconnected.
	PITCH TRIM BKUP FAIL	Backup pitch trim switch is inoperative.
	PITCH TRIM SW 1 FAIL	Captain's pitch trim switch is inoperative.
	PITCH TRIM SW 2 FAIL	First Officer's pitch trim switch is inoperative.
	PITCH TRIM LO RATE	Pitch trim system can only operate at a low rate.
	ROLL CONTROL DISC	Control wheels are disconnected.
	SLAT LO RATE	One of the Slats electronic control channels is inoperative and the slat system is still available but in low speed.

TYPE	MESSAGE	MEANING
ADVISORY	SPDBRK LEVER DISAG	A mismatch exists between the speedbrake handle position and the multifunction spoiler surfaces or the ventral speed brake.
	TAILSTRIKE PROT FAIL	TSA function is no longer available.
STATUS	FLT CTRL TEST IN PROG	Electrical PBIT in progress.