

Snell & Wilcox SUPERVISOR

Multi-Standard Display Processor

Transit Protection-Important Notice

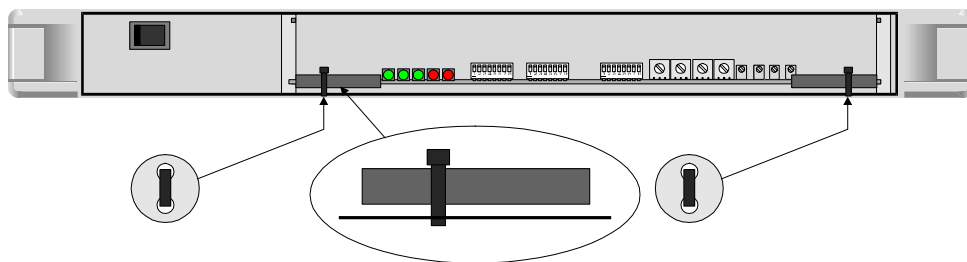

REMOVING THE TRANSIT TIE-WRAPS

When supplied the PCB card will be secured by 2 tie-wraps, looped around the card ejectors and through 2 holes in the base plate. Before installing the rack both of the tie-wraps should be removed by cutting off the tie-wrap knot and completely removing the tie-wrap.

REPLACING THE TRANSIT TIE-WRAPS

Before shipping, the transit tie-wraps should be replaced with the spare tie-wraps supplied (part no. RMW610). With the unit free-standing ensure that the PCB card is pushed fully home using the card ejectors. From the inside of the unit, feed the tongue of the tie-wrap behind the card ejector and through the base plate using the rear of the 2 holes. From the outside, feed the tongue back through the base plate using the other hole, past the front of the card ejector, feed through the eye of the tie-wrap, pull tight and cut off the excess.

Operator's Manual

© July 2001

SNELL & WILCOX LTD, DURFORD MILL, PETERSFIELD, HAMPSHIRE, GU31 5AZ, UNITED KINGDOM.
Tel: +44(0) 1730 818700. Fax: +44(0) 1730 821199.

About this Manual

This manual covers the following product:

- SuperVisor Multi-Standard Display Processor

Software Version Amendments

Notes about Versions Fitted

Firmware. This SuperVisor is shipped with Version 7.0 of the firmware.

Manufacturers Notice

Copyright protection claimed includes all forms and matters of copyrightable material and information now allowed by statutory or judicial law or hereinafter granted, including without limitation, material generated from the software programs which are displayed on the screen such as icons, screen display looks etc.

Reproduction or disassembly of embedded computer programs or algorithms prohibited.

Information in this manual and software are subject to change without notice and does not represent a commitment on the part of Snell & Wilcox Ltd. The software described in this manual is furnished under a licence agreement and may not be reproduced or copied in any manner without prior agreement with Snell & Wilcox Ltd. or their authorised agents.

Important Warning

Before installation ensure that the warning label on the rear top of the unit is read and understood

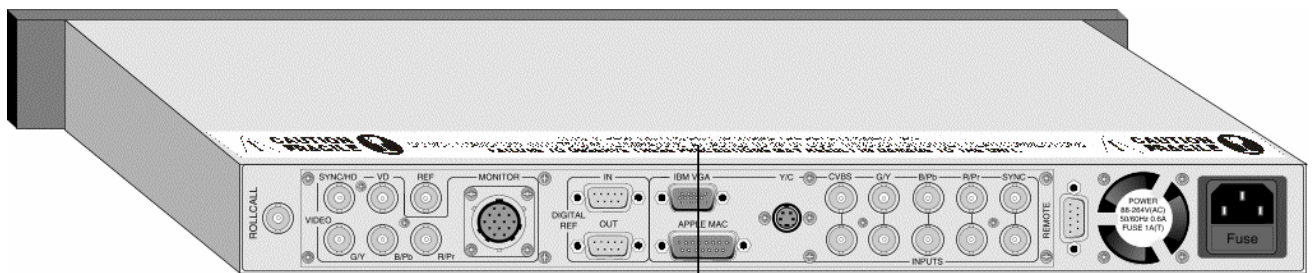

CAUTION FRAGILE DO NOT REST UNIT ON END OR STRIKE THE REAR CONNECTORS
DO NOT TRANSPORT WITH 75 OHM TERMINATORS ATTACHED TO INPUT LOOP THROUGH OR OTHER REAR CONNECTIONS
FAILURE TO OBSERVE THESE PRECAUTIONS MAY RESULT IN DAMAGE TO THE UNIT. **CAUTION FRAGILE**

**DO NOT REST UNIT ON END OR STRIKE THE REAR CONNECTORS
DO NOT TRANSPORT WITH 75 OHM TERMINATORS ATTACHED TO INPUT LOOP THROUGH OR
OTHER REAR CONNECTIONS
FAILURE TO OBSERVE THESE PRECAUTIONS MAY RESULT IN DAMAGE TO THE UNIT.**

Safety Warnings

Always ensure that the unit is properly earthed and power connections correctly made.

This equipment shall be supplied from a power system providing a **PROTECTIVE EARTH**  connection and having a neutral connection which can be reliably identified.

The power terminals of the IEC mains input connector on the rear panel are identified as shown below:

E = Protective Earth Conductor

N = Neutral Conductor

L = Live Conductor

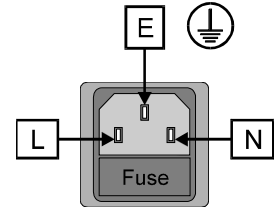

Power cable supplied for countries other than the USA

The equipment is normally shipped with a power cable with a standard IEC moulded free socket on one end and a standard IEC moulded plug on the other. If you are required to remove the moulded mains supply plug, dispose of the plug immediately in a safe manner. The colour code for the lead is as follows:

GREEN/YELLOW lead connected to E (Protective Earth Conductor)

BLUE lead connected to N (Neutral Conductor)

BROWN lead connected to L (Live Conductor)

Power cable supplied for the USA

The equipment is shipped with a power cord with a standard IEC moulded free socket on one end and a standard 3-pin plug on the other. If you are required to remove the moulded mains supply plug, dispose of the plug immediately in a safe manner. The colour code for the lead is as follows:

GREEN lead connected to E (Protective Earth Conductor)

WHITE lead connected to N (Neutral Conductor)

BLACK lead connected to L (Live Conductor)

The terminals of the IEC mains supply lead are identified as shown opposite:

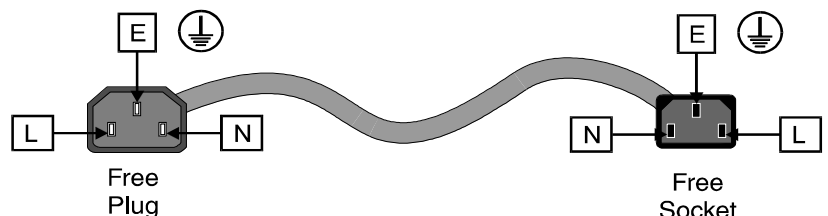

Note that for equipment that is not fitted with a mains power switch, to comply with BS60950 Clauses 1.7.2 and 2.6.9, the power outlet supplying power to the unit should be close to the unit and easily accessible.



Warnings

Voltages within this unit can be lethal under certain circumstances. Where power is required to be connected to the unit during servicing great care must be taken to avoid contact with these voltages.

Maintenance should only be carried out by suitably qualified personnel.

No part of this publication may be transmitted or reproduced in any form or by any means, electronic or mechanical, including photocopy, recording or any information storage and retrieval system, without permission being granted, in writing, by the publishers or their authorised agents.

EMC Standards



This unit conforms to the following standards:

Electromagnetic Compatibility-Generic Immunity Standard BS EN 50082-1:1992

The European Standard EN 50082-1:1992 has the status of a British Standard and is related to European Council Directive 89/336/EEC dated 3rd May 1989.

Electromagnetic Compatibility-Generic Emission Standard BS EN 50081-1:1992

The European Standard EN 50081-1:1992 has the status of a British Standard and is related to European Council Directive 89/336/EEC dated 3rd May 1989.

Federal Communications Commission Rules Part 15, Class A :1998

Safety Standards

This unit conforms to EN60065:1992 as amended by amendment A1(May 1993) and amendment A2(March 1994). Specification for safety of technology equipment, including electrical business equipment.

EMC Performance of Cables and Connectors

Snell & Wilcox products are designed to meet or exceed the requirements of the appropriate European EMC standards. In order to achieve this performance in real installations it is essential to use cables and connectors with good EMC characteristics.

All signal connections (including remote control connections) shall be made with screened cables terminated in connectors having a metal shell. The cable screen shall have a large-area contact with the metal shell.

COAXIAL CABLES

Coaxial cables connections (particularly serial digital video connections) shall be made with high-quality double-screened coaxial cables such as Belden 8281 or BBC type PSF1/2M.

D-TYPE CONNECTORS

D-type connectors shall have metal shells making good RF contact with the cable screen. Connectors having "dimples" which improve the contact between the plug and socket shells, are recommended.

Packing List

The unit is supplied in a dedicated packing carton provided by the manufacturer and should not be accepted if delivered in inferior or unauthorised materials. Carefully unpack the carton and check for any shipping damage or shortages.

Check against the following list. Report any shortages or damage to the supplier immediately.

- Shipping Damage
- Shortages
- Mainframe
- Module(s)
- Power cable
- Operator's Handbook

Table of Contents

SECTION	Page
1 Introduction	
Description	1.1
Features	1.2
2 Specifications	
Input Signal Data	2.1
Output Signal Signal Data	2.2
Technical Data	2.4
Operational Controls	2.5
Remote Control System	2.8
3 Installation	
Power Connections	3.1
Communications Connections	3.1
Input Connections	3.2
Output Connections	3.6
Multiple Unit Systems	3.8
VGA Keying	3.9
4 Applications-Tips on how to use your SuperVisor	
Projector Types	4.1
Basic Issues of Projection	4.3
Set up Tips	4.4
5 Operation	
Menu System Diagram	opp. 5.1
Front Panel Controls-General Information	5.1
Using the Menu System	5.5
Front Panel Push Buttons	
Selecting a Pattern, Output Menu, Memory Functions, VGA Key and Default Settings	5.8
Menu Details	
Input Signal Scan Rate	5.9
Output Signal Scan Rate	5.10
Input Signal Format	5.11
Output Signal Format	5.12
Test Pattern Selection	5.14
Processing Controls	5.15
Output Picture Size	5.18
Picture Pan and Tilt	5.19
Output Picture Aspect Ratio	5.22
Keying	5.24
Effects	5.26
Genlock	5.28
System Parameters	5.29
Memory Functions	5.31
PCB Module Controls	5.32
6 Driving the SuperVisor from a PC using an RS422 Interface	6.1

Introduction

DESCRIPTION

The **SUPERVISOR** is a **display processor** designed to improve the quality of pictures displayed on devices such as large screen projectors, video walls, large screen monitors etc. with input sources of base band video and computer graphics.

The unit is contained in a single 1U rack case, meeting current EMC regulations (BS50081-1 for emission and BS50082-1 for immunity)

Control is via an advanced Multi-Function front panel using a powerful Menu system and push buttons or by a comprehensive remote control system (see Section 2)

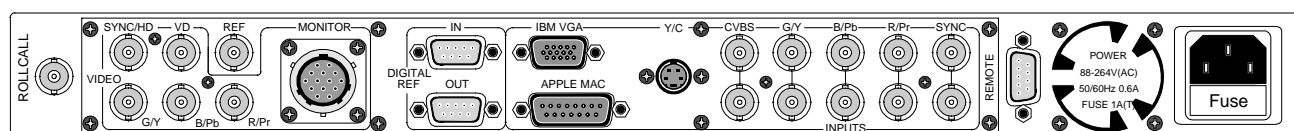
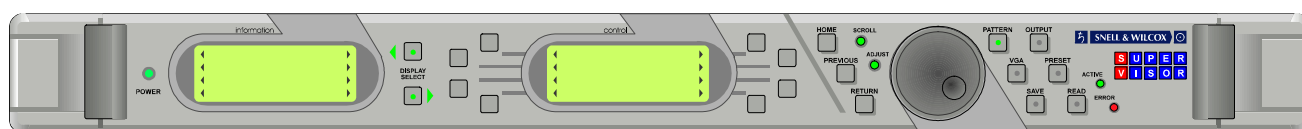

Introduction

FEATURES

- HIGH QUALITY improvement of images displayed on large screen devices
- Full Spatio-Temporal Interpolation with 9 point aperture (NOT a line doubler)
- Line and field rate up-conversion to reduce raster visibility and flicker
- Accepts inputs of 625, 525 and VGA Computer standards (including interlaced and progressive)
- HDTV input option available
- Analogue Component inputs (Composite input option available)
- Provides a variety of outputs with increased line and field rates in interlaced or progressive form
- VGA and MAC computer standard outputs
- Multi-standard genlocking facilities
- Can change aspect ratio between 4:3 and 16:9 formats with size variation
- Two dimensional image re-sizing
- Accurate positioning of image
- Unique ten step gamma correction
- Built-in test pattern generator for display alignment
- Facility to KEY(overlay) computer pictures into the video input signal
- Self-contained in a 1U rack case with low power consumption
- Single segment video wall display driver/processor built-in
- Two menu-driven LCD displays for simple operation
- Six memory locations for storage and recall of selected parameters

Specifications

INPUT CONNECTIONS

Component RGB(S)	Separate inputs of Red, Green and Blue at standard level of 0.7V p-p , (with 0.3V Sync on Green channel or separate syncs) when via loop-through BNC connectors for 75 Ohms.
Component	Separate inputs of Y, Pb and Pr at standard level of 0.7V p-p luminance (with 0.3V Syncs or separate syncs) and 0.7V p-p U & V, when terminated in 75 Ohms using the same loop-through BNC connectors as the RGB inputs.
Syncs	Mixed syncs at 0.3V to 2V p-p via BNC loop-through connectors for 75 Ohms.
Computer	Standard IBM CGA,VGA ,SVGA levels via 15 pin High Density 'D' connector Standard MAC levels via 15 pin 'D' connector <i>Note that SuperVisor requires separate H and V syncs from both VGA and MAC™ inputs; it is not designed to work with a composite sync input from these sources.</i>
If Optional PAL or NTSC Decoder is Fitted:	
Composite	Composite video at 1V p-p level when terminated in 75 Ohms via loop-through BNC connectors
Separated Y/C	Y signal 1V p-p, C signal 0.3V p-p burst , both terminated in 75 Ohms via 4-pin Mini-DIN connector.
Reference	Standard Video or black burst via BNC connector terminated in 75 Ohms Digital positive or negative going Horizontal and Vertical drive,TTL levels via active loop-through,9 pin 'D' Connectors <i>Note that this connector is used for the HDTV Tri-Sync input when the HDTV option is fitted.</i>

INPUT STANDARDS

Video	625 Line, 50 Hz, interlaced 2:1 525 Line, 59.94 Hz, interlaced 2:1
Computer (IBM Standard)	CGA 320x400/60/1:1 VGA 640x480 /60/1:1 SVGA 800x600/56/1:1
HDTV (Optional)	1250 Line, 50 Hz, interlaced 2:1 1125 Line, 60 Hz, interlaced 2:1 1050 Line, 60 Hz, interlaced 2:1

Specifications

OUTPUT CONNECTIONS

Component RGB	Separate outputs of Red, Green and Blue at standard level of 0.7V p-p , (with Sync on Green channel, see note 1) when terminated in 75 Ohms via the BNC connectors and via the 14 pin multi-way connector.
OR	
Component	Separate outputs of Y, Pb and Pr at standard level of 1V p-p luminance and 0.7V p-p PbPr, when terminated in 75 Ohms using the same BNC connectors as the RGB outputs and via the 14 pin multi-way connector. (Note 1)

Note 1: Syncs may also be added to the red and blue or U and V signals by means of a jumper link

Sync	An output of standard mixed syncs at a level of 2V p-p into 75 Ohms or at TTL compatible level, via BNC connector OR
HD	An output of horizontal drive at a level of 2V p-p into 75 Ohms or at TTL compatible level, using the same BNC connector as the Sync output
VD	An output of vertical drive at a level of 2V p-p into 75 ohms or at TTL compatible level via a BNC connector

Note: The sync/HD/VD output level is selected by links; see page 5.11 for details.

Digital Reference	Digital positive or negative going Horizontal and Vertical drive at TTL compatible levels via 9 pin 'D' Connector
-------------------	---

Specifications

OUTPUT SCANNING STANDARDS

Output Standards Available

Line Rate or Pixels	Field Rate Hz	Interlace Ratio	Comments	VGA Key Mode Available
625	100	2:1		No
625	50	1:1		No
1250	50	2:1		No
875	75	2:1		No
525	119.88	2:1		No
525	59.94	1:1		No
1050	59.94	2:1		No
735	89.90	2:1		No
320 x 400	60	1:1	CGA	Yes
640 x 480	60	1:1	VGA	Yes
800 x 600	56	1:1	SVGA	Yes
800 x 600	60	1:1	SVGA	Yes
800 x 600	72	1:1	SVGA	Yes
800 x 600	75	1:1	SVGA	Yes
640 x 480	67	1:1	MAC	Yes
832 x 624	75	1:1	MAC	Yes
1125	60	2:1		No

Specifications

TECHNICAL DATA

*Conditions: Input Signal Component YPbPr and Composite unless other indicated.
Output Signal 625 50 1:1 RGB.*

Frequency Response	YPbPr	-1 dB at 4 MHz, -3 dB at 8 MHz
	Composite	-1 dB at 6 MHz
Pulse Response (YPbPr and Composite)	2T pulse to bar	<1% K rating
	2T pulse response	<1% K rating
	Bar response (20 us)	<1% K rating
Tilt	Line tilt	<1%
	Field tilt	<1%
Residual Jitter		<±10 ns
Y-C Delay Correction	Horizontal	± 900 ns in 56 ns steps
	Vertical	± 8 lines in 1 line steps
Procamp Controls	Video (Luma) gain	± 3 dB
	Chroma gain	± 3 dB
	Black level	± 50 mV
	NTSC hue	± 20 degrees

Specifications

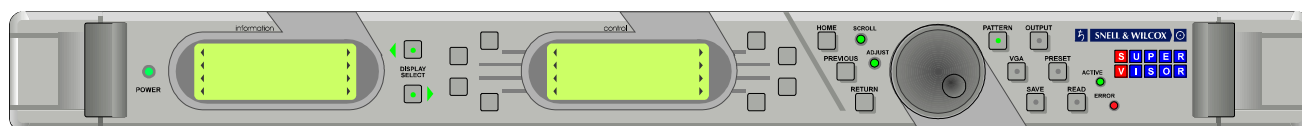

OPERATIONAL CONTROLS

The Supervisor has extremely flexible multi-function controls which combine hard and soft key functions.

SELECTABLE FUNCTIONS AND PARAMETERS

(See Section 3 'OPERATION' for operating procedure)

Function	Parameter Select	Range
Input Signals	Composite (if decoder option fitted)	Aspect Ratio 4:3/16:9
	RGB/RGBS	Aspect Ratio 4:3/16:9
	YPbPr/YPbPrS	Aspect Ratio 4:3/16:9
	Y/C	Aspect Ratio 4:3/16:9
	VGA	320 x 400 Pixels CGA
	VGA	640 x 480 Pixels VGA
VGA	800 x 600 Pixels SVGA	
Output Signals	RGB/YPbPr	RGB, YPbPr
	Syncs	Add Syncs to Green or Y Mixed sync at SYNC/HD connector HD at SYNC/HD connector and VD at VD connector
Genlock	Off	
	Reference input	
	Digital input	
	Genlock H-Phase	$\pm 1600\text{ns}$
Genlock V-Phase	± 4 lines	

Specifications

Function	Parameter Select	Range
Pan	Horizontal	$\pm 75\%$ of input picture width
Tilt	Vertical	$\pm 75\%$ of input picture height
Size	Horizontal	Reduce by 1.5:1, increase by 4:1 (Output picture size compared to input)
Size	Vertical	Reduce by 1.5:1, increase by 4:1 (Output picture size compared to input)
Signal Processing	Luminance gain	$\pm 3\text{dB}$
	Chrominance gain	$\pm 3\text{dB}$
	Black Level	$\pm 50\text{mV}$
	NTSC Hue	$\pm 20^\circ$ (if decoder option fitted)
Pattern Generator	Select Patterns	100% Bars Bars and Red Crosshatch Step (Gamma) Ramp Multiburst Pluge Black White
Filter Characteristics	Sharp(ness)	Horizontal 0 to +9dB in 3dB steps Vertical 0 to +9dB in 3dB steps
Effects	Picture	Y Invert On/Off Monochrome On/Off Gamma Correction 1 to 10 curve selections Freeze frame
Computer KEY	Off Wipe Key Invert	Vertical Wipe Point adjustable to cover all picture lines Key from R+G+B, level adjustable 0 to 100%
Video Wall	Wall Shape	Select Video Wall shape 1 x 2, 1 x 3, 1 x 4. 2 x 1, 2 x 2, 2 x 3, 2 x 4. 3 x 1, 3 x 2, 3 x 3, 3 x 4. 4 x 1, 4 x 2, 4 x 3, 4 x 4.
Cube Select	Cube Number	Choose 1 to 16

Specifications

MAINFRAME

The unit is ruggedly constructed in a 19" steel rack mount case.

Dimensions	483mm wide, 45mm high, 395mm deep.
Weight	5kg.
Temperature range	0 to 40°C operating, -30 to +75° storage

Power Supply

Mains power	88V to 264V 50/60Hz
Input Connector	IEC320 Fused 1A(T)
Power On/Off Switch	Located behind drop-down front panel
Power Consumption	50VA maximum
Cooling	A cooling fan is fitted to the rear panel of the unit.

Remote Control

Typical RollCall™ System

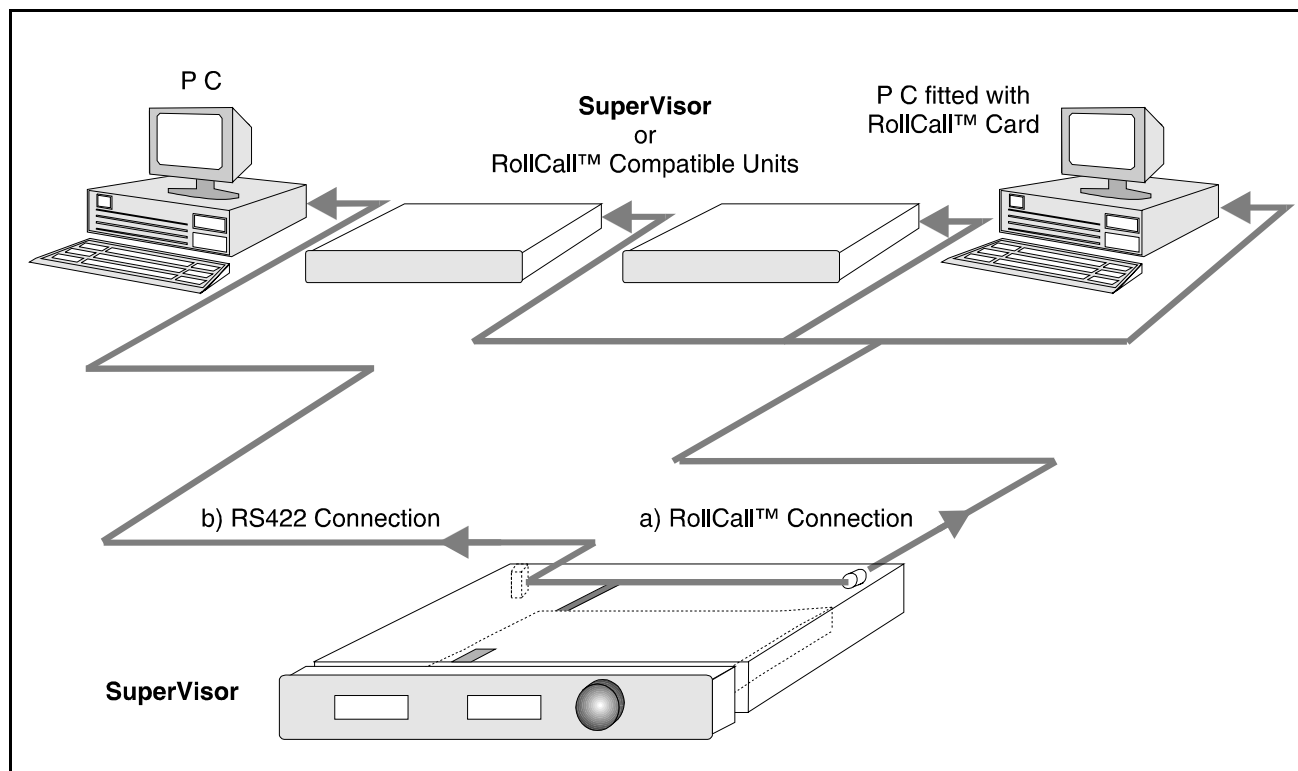

ROLLCALL™ OVERVIEW

The RollCall™ system provides full remote control of compatible units using graphical control panels and may be used to control many units simultaneously. The remote control software communicates via remote control interface circuitry which may be a separate card fitted into a rack mount unit or, as in the SuperVisor, be integrated into the main PCB.

Rollcall™ communication may be via either a 9 pin 'D' connector configured to RS485 or via a 75 Ohm coaxial cable connection to the network allowing long distance multi-drop coaxial inter-connections. The address of a unit is set by two Hex switches, each unit having a different address. In addition the 9 pin 'D' connector may be configured to be an RS422 port, allowing single point-to-point communication with a simplified set of Protocols.

The system may support multiple slave operation, multiple control operation or as a single network with a choice of coaxial or RS485 interface connection. High data rates of 2.5Mbits/sec are used on the coaxial port and RS485 port, and up to 38.4Kbits/sec on RS422 port.

Remote Control

SUPERVISOR ROLLCALL™ CONNECTIONS

Coaxial Connection (a)

The RollCall™ coaxial connection allows interfacing with other RollCall™ compatible equipment, fitted with the RollCall™ BNC connector, over a maximum distance of 400 m using PSF1/2 cable or 300 m using RG59/U.

Under these conditions control is available from any other RollCall™ control device; conversely the SuperVisor can then control other units connected to the RollCall™ network.

RS485 to Front Panel

The SuperVisor mainframe may be remotely operated from the front panel using the ribbon cable connection over a maximum cable length of 30 m.

9-pin 'D' Connection (b)

This system uses RS422 or RS485 interface for connection to a P.C. SW4 on the front edge of the SuperVisor PCB selects the required mode.

RS422 (SW4 in the down position)

This mode allows the unit to be connected to a P.C. and provides full control of all functions using a simplified subset of RollCall™ protocol. This Protocol is included in Appendix A. Data rate is 38.4 kbauds and maximum recommended cable length is 30 m.

In this mode only point-to-point control of the connected SuperVisor is supported

RS485 (SW4 in the up position)

This mode provides an interface at 2.5 Mbps which is fully RollCall™ compatible, supporting all RollCall™ capabilities. Note that any controller *must* meet full RollCall™ specifications. For support and advice about specific applications please contact Snell & Wilcox or your supplier.

REMOTE CONTROL CONFIGURATIONS FOR SUPERVISOR

Remote SuperVisor Front Panel (up to 30 m)

This method allows the distance between the SuperVisor mainframe and its front panel to be extended by up to 30 metres using a Passive Shoebox.

A shoebox is a standard 19" rack mount box but only 100 mm deep. This box allows standard 1U front panels to be operated remotely from a mainframe and housed conveniently in the standard 19" format.

The Passive Shoebox is a passive box requiring no external power (product code IQHSBOX-S) using RS485 communication (maximum cable length 30 m). This unit has the advantage of not requiring any mains power (low voltage power is derived from a mainframe; for example a SuperVisor unit), allowing control from an un-powered location. A spare SuperVisor blank front panel is provided that can be fitted to the mainframe to replace the active front panel which now resides in the shoebox.

Remote Control

Remote Front Panel (over 30 m)

This method allows remote control over distances greater than 30 metres using an Active Shoebox.

An active form of the Shoebox is used (product code IQHSBOX-RC-AP-S) which is mains powered, and supplied complete with a SuperVisor front panel and RollCall™ remote control interface card for coaxial and RS422 communication systems.

The original SuperVisor front panel remains fitted to the mainframe and the shoebox, with a SuperVisor front panel used to control the SuperVisor from a remote location. Communication is via the RollCall™ BNC coaxial system and dual control is possible.

Remote Control from a Controller

RS422/RS485

Using this method the SuperVisor unit remains intact complete with its front panel fitted into the mainframe and uses the 9 pin 'D' connector in the RS422 mode. *Note that for this mode of operation SW4 on the front of the PCB must be in the DOWN (default) position.*

This allows the unit to be connected to a P.C. and provides full control of all functions using a simplified subset of RollCall™ protocol. This Protocol is include in Appendix A. Data rate is 38.4 kbauds and maximum recommended cable length is 30 m.

It should be noted that when using RS422 (point-to-point connection) one serial port per unit is controlled; if RS485 is used (multiple-drop, SW4 set to the UP position) many units can be connected to the same bus.

The RS485 mode provides an interface at 2.5 Mbps which is RollCall™ compatible. This has full RollCall™ networking capabilities. Note that any controller *must* meet full RollCall™ specifications. For support and advice about specific applications please contact Snell & Wilcox or your supplier.

Windows™ Based Program

Snell & Wilcox can provide a Windows™ based P.C. RollCall™ program to control one or more units via using either the RS232 port of the computer (an adapter to RS422 will be required) or via a RollCall™ BNC coaxial port, for which a P.C. card is available.

Remote Control

Control of SuperVisor with other RollCall™ Units

Other RollCall™ units, fitted with a KUDOS IQ active front panel, may be used to control the SuperVisor.

The KUDOS IQ active front panel is very similar to the SuperVisor front panel, the only differences between the two panels are the functions of some of the dedicated push buttons shown more clearly below:

KUDOS IQ Active Front Panel

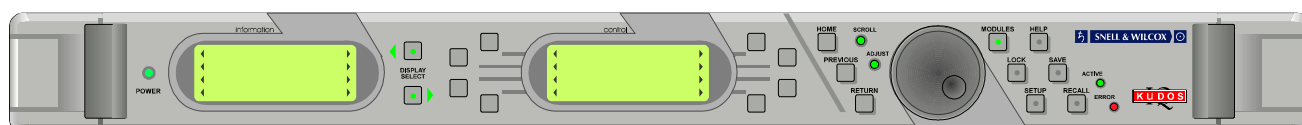

SuperVisor Front Panel

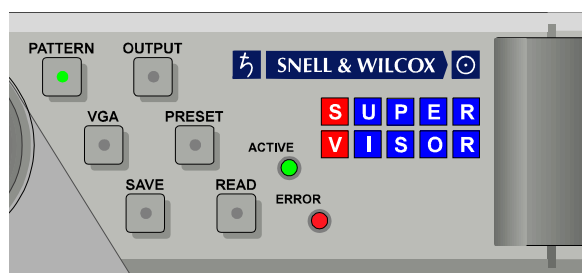

KUDOS IQ Active Front Panel

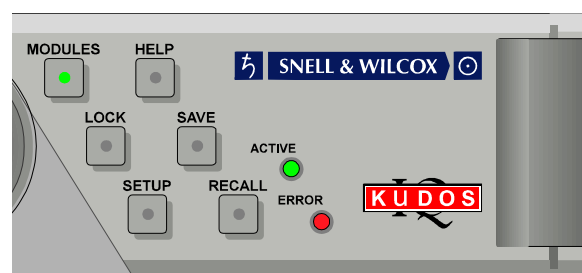

When using the KUDOS IQ active front panel to control the SuperVisor unit, the display windows and their associated push buttons, will function in the same way as those on a SuperVisor front panel; however, the dedicated push buttons will operate functions as described in Section 1 of the *KUDOS IQ Modular System, Operator's Manual, 1U Active Control Panel, Dedicated Push Buttons*.

To access the Pattern, Output, VGA, Preset, Save and Read functions (dedicated buttons on the SuperVisor front panel, but buttons not available on the KUDOS IQ active front panel) connect to the SuperVisor unit using the Modules function (see *KUDOS IQ Modular System, Operator's Manual*) go to the SuperVisor main menu and proceed as follows:

Pattern	Select Patterns... from the menu to reveal the Pattern Select Menu and use the Pattern Active function to enable or disable the pattern
Output	Select Out Rate... from the menu to reveal the Output Scan Rate Menu and make the desired selection
VGA	Select VGA Key... from the menu to reveal the VGA Key Options Menu and use the VGA Key Active function to enable or disable the VGA key function
Preset	Select System... from the menu to reveal the System Menu and use the Preset Unit function
Save	Select Memsave... from the menu to reveal the Memory Save Menu and save to the desired memory location
Read	Select Memread... from the menu to reveal the Memory Read Menu and read from the required memory location

Installation

POWER CONNECTIONS

This is the IEC320 mains power connector suitable for a standard IEC type power cable and contains a 1A(T) fuse. If a fused type plug is fitted to the cable a fuse of 5A (F) rating should be installed.

POWER ON/OFF SWITCH

The power ON/OFF switch is located behind the drop-down front panel in the left hand corner.

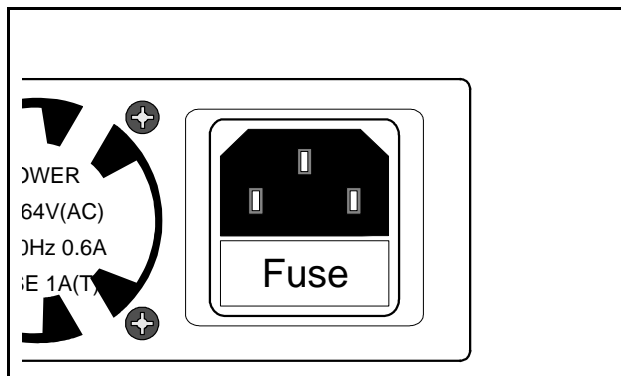

LED INDICATORS

The green LED indicator on the front panel marked POWER will be illuminated when the unit is powered-up.

The LED marked ACTIVE will be illuminated when the front panel is connected to and communicating with the mainframe electronics.

The LED marked ERROR will flash indicating that there has been a communications error between the front panel and the mainframe electronics.

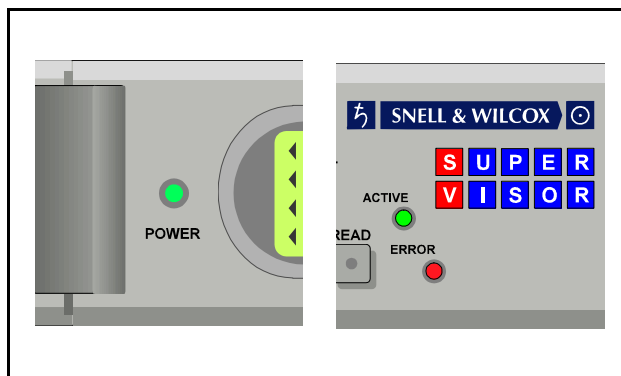

REMOTE COMMUNICATIONS CONNECTOR

This 9 pin 'D' connector on the rear panel is the remote control connector that allows interconnection to be made to remote or other front panels in a multiple-unit system.

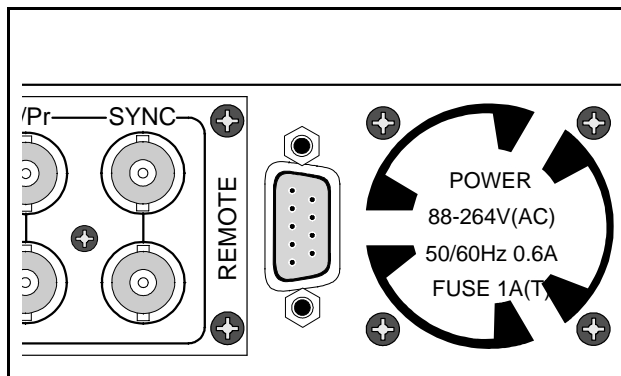

ROLLCALL™

This single BNC connector allows the unit to be connected to the RollCall™ network communications system. For more details of this system see Section 2.

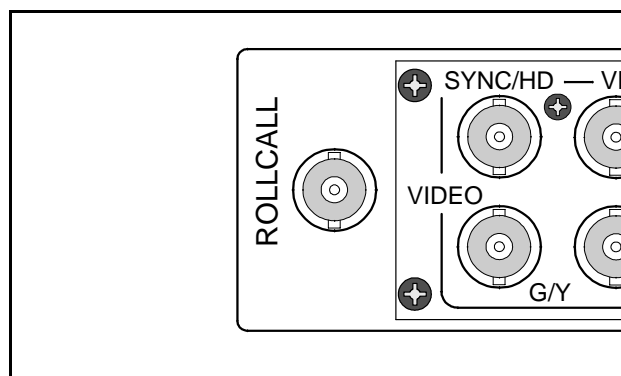

Installation

INPUT CONNECTIONS

COMPOSITE INPUT (if decoder option is fitted)

This is the composite (CVBS) video input to the unit via loop-through BNC connectors for 75 Ohms. If the loop-through facility is not used a BNC 75 Ohm terminating plug should be fitted on the unused connector. Nominal input level is 1V p-p.

This input is selected using the front panel controls.

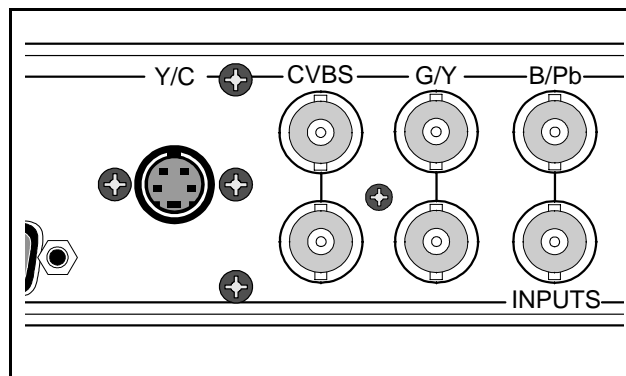

Y/C INPUT (if decoder option is fitted)

A Y/C separated luminance/chrominance type signal may be connected to the unit via this 4-pin Mini-DIN connector which terminates both signals in 75 Ohms.

Y input level is a nominal 1V p-p into 75 Ohms and C level is a nominal 0.3V p-p colour burst into 75 Ohms.

Connections are given below:

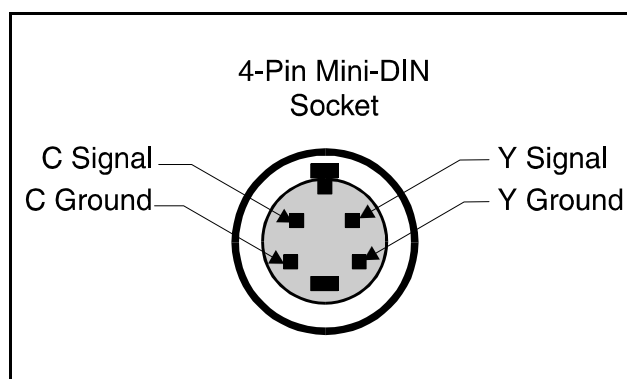
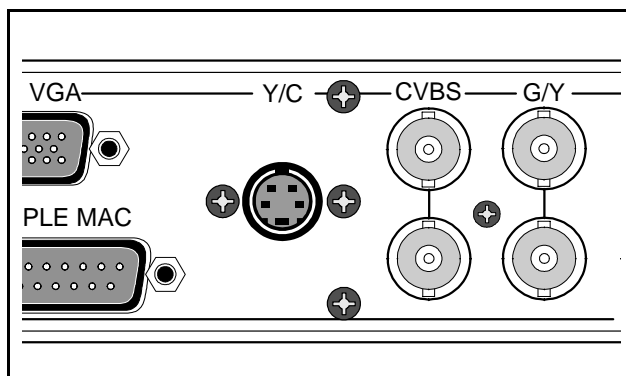

Installation

COMPONENT INPUTS

Component RGB or YPbPr inputs are accepted via these three sets of loop-through BNC connectors for 75 Ohms.

If the loop-through facility is not used a BNC 75 Ohm terminating plug should be fitted on the unused connector.

For RGB signals

Connect **Green** signal to the **G/Y** connector
 Connect **Blue** signal to the **B/Pb** connector
 Connect **Red** signal to the **R/Pr** connector

Signal levels are 0.7V p-p into 75 Ohms with syncs on the green channel.

For YPbPr signals

Connect **Y** signal to the **G/Y** connector
 Connect **Pb** signal to the **B/Pb** connector
 Connect **Pr** signal to the **R/Pr** connector

Signal levels are 0.7V p-p into 75 Ohms with syncs on the Y channel.

This input and the signal format is selected using the front panel controls.

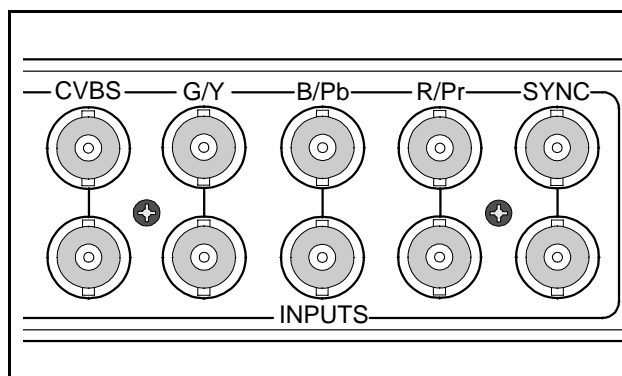

SYNC INPUT

A loop-through connection via BNC connectors for 75 Ohms is provided that will accept a standard mixed sync signal. This connection should be used if either the RGB or YPbPr input is non-composite (contains no sync information) and a source of separate syncs is available.

If the loop-through facility is not used a BNC 75 Ohm terminating plug should be fitted on the unused connector.

This input and the signal format is selected using the front panel controls.

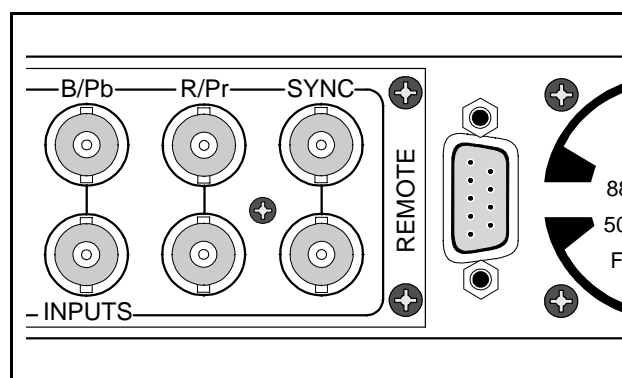

Installation

VGA (Computer Input)

Input signals from a computer source should be connected to the unit using this 15-pin mini 'D' type connector. The connections are compatible with computers using the same type of connector for IBM (or compatible) CGA, VGA and SVGA signals.

This input, its usage and the signal format is selected using the front panel controls.

Pin Connections

1	Red Video	6	Red Ground	11	Ground
2	Green Video	7	Green Ground	12	Not used
3	Blue Video	8	Blue Ground	13	H-Sync
4	Ground	9	Not Used	14	V-Sync
5	Ground	10	Ground	15	Not used

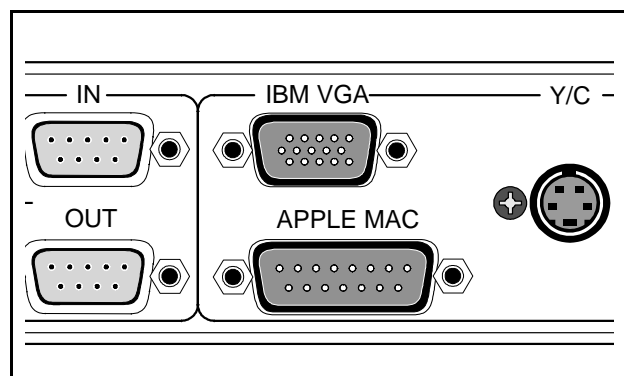

APPLE MAC™ (Computer Keying only)

This 15-way, standard density male 'D' connector allows signals from an Apple Mac™ computer to be connected to the unit.

Pins Connections

1	Red Ground	6	Green Ground	11	Sync Ground
2	Red Video	7	Mode	12	V-Sync
3	N/C	8	N/C	13	Blue Ground
4	Mode	9	Blue Video	14	Sync Ground
5	Green Video	10	Mode	15	H-Sync

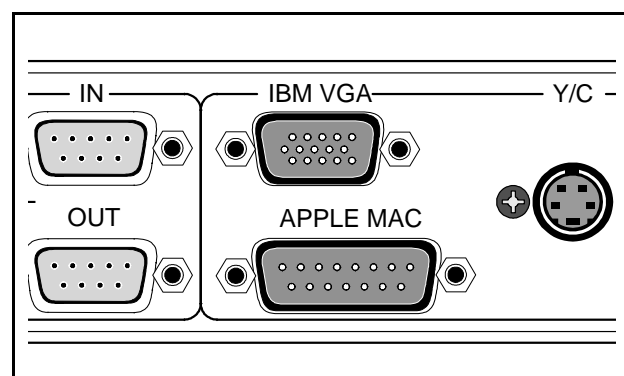

WARNING

As the VGA and APPLE MAC™ computer input connectors are connected in parallel, only one of these connectors should be used. Under no circumstances should connections be made to both of the connectors at the same time.

VGA Keying with APPLE MAC's™

The SuperVisor supports 3 APPLE MAC rates, 640 x 480 (13"), 832 x 624 (16") and VGA emulation. APPLE MAC's™ read status lines from the monitor on reset (only) in order to determine their output rate. In order for the SuperVisor to imitate an APPLE MAC™ monitor LK1 and LK2 must be set as shown opposite. (Remove top cover for access)

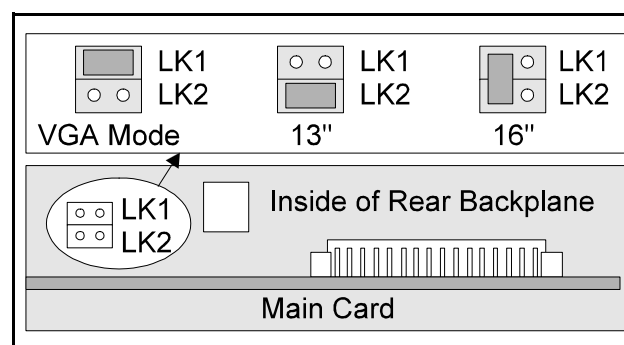

Installation

Alternative methods include powering-up the MAC™ with a monitor connected to set the MAC™ into the correct output standard and then reconnecting the MAC™ to the SuperVisor. When the MAC™ is emulating VGA then the SuperVisor will have to set to the relevant VGA outputs. This mode does however give the capability of inputting MAC™ into the SuperVisor.

REFERENCE (Analogue)

Note that currently this analogue input does not support higher rate line and field signals. For such signals, e.g. from another SuperVisor unit, the Digital reference input should be used.

The unit and its output signals may be reference locked to an external analogue (black burst or composite video) signal using the 'REF' connector. This input expects a standard level signal and terminates in 75 Ohms.

This input and the signal format is selected using the front panel controls.

Note that any reference signal supplied must be compatible with the selected output scan rate standard.

HDTV Input Option

When this option is fitted, this connector is used to process the Tri-Sync signals contained in the GREEN signal which should be looped-through the G/Y input.

REFERENCE (Digital)

The unit and its output signals may also be reference locked to an external digital source (e.g. another Supervisor unit) via this 9 pin 'D' connector marked 'IN'. TTL horizontal and vertical drive signals are used, which may be positive or negative going.

This input is selected using the front panel controls.

The 9 pin 'D' DIGITAL REF OUT connector provides outputs of TTL horizontal and vertical drive signals at ALL times.

The output signal format is selected using the front panel controls and pin connections are as follows:

- 1 Ground
- 5 H-Sync
- 4 V-Sync

All other pins are unused.

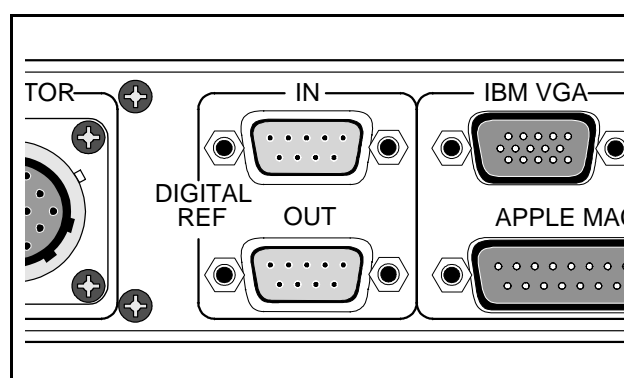
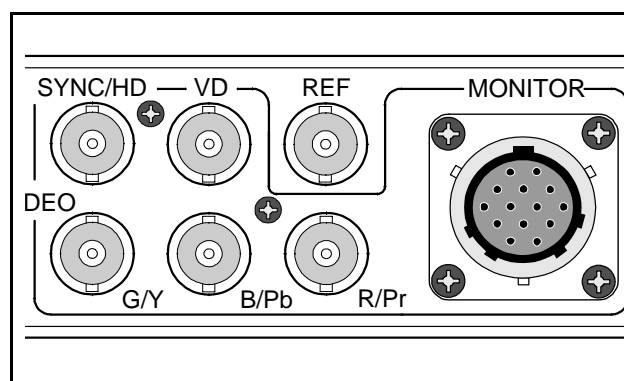

Installation

OUTPUT CONNECTIONS

COMPONENT OUTPUTS

Component RGB or YPbPr outputs are available from these BNC connectors at 75 Ohms impedance.

For RGB signals

Use **G/Y** connector for **Green** output signal

Use **B/Pb** connector for **Blue** output signal

Use **R/Pr** connector for **Red** output signal

Signal levels are non-composite 0.7V p-p into 75 Ohms. Syncs may be added to the green channel using the Output Format menu and to the Red and Blue channels by means of a jumper link LK5 (see 'Preset Control Functions')

For YPbPr signals

Use **G/Y** connector for **Y** output signal

Use **B/Pb** connector for **U** output signal

Use **R/Pr** connector for **V** output signal

Signal levels are non-composite 0.7V p-p into 75 Ohms. Syncs may be added to the Y channel using the Output Format menu and to the Pb and Pr channels by means of a jumper link LK5 (see 'Output Signal Format' Section 4, Operation)

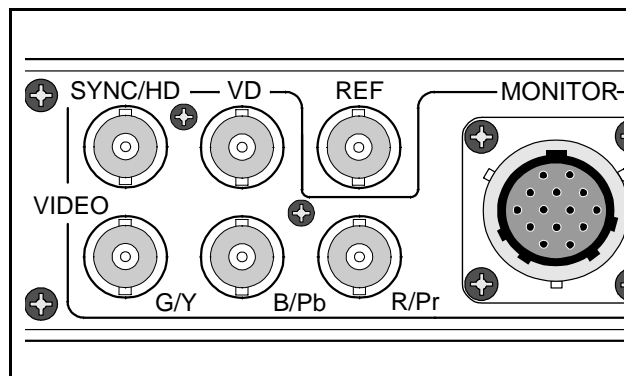

MONITOR OUTPUT

The same component signals detailed above are also available from this 14-pin connector which is suitable for connection to specific projector displays.

Pin Connections

1 Ground	6 B/Pb output	11 R/Pr output
2 HD/Sync	7 Ground	12 N/C
3 N/C	8 Ground	13 N/C
4 N/C	9 G/Y output	14 VD
5 N/C	10 N/C	

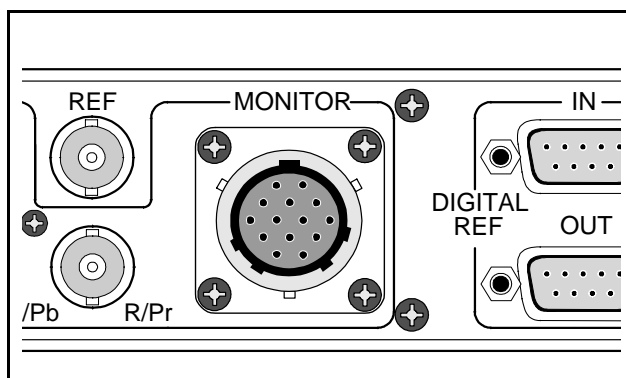

Installation

SYNC/HD OUTPUT

This BNC connector provides an output of either standard mixed syncs or Horizontal Drive, positive or negative going, selected using the front panel controls.

The output may be an analogue signal for 75 Ohms or a TTL compatible signal, selected by internal links.

For more details see Output Signal Format, Section 4 'Operation'

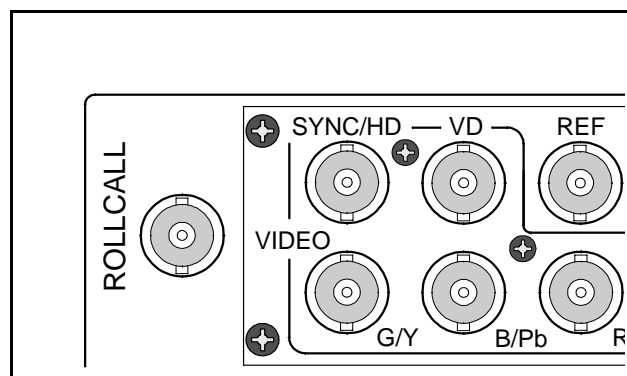

VD OUTPUT

This BNC connector provides an output of vertical Drive and may be either positive or negative going, selected using the front panel controls.

The output may be an analogue signal for 75 Ohms or a TTL compatible signal, selected by internal links.

For more details see Output Signal Format, Section 4 'Operation'

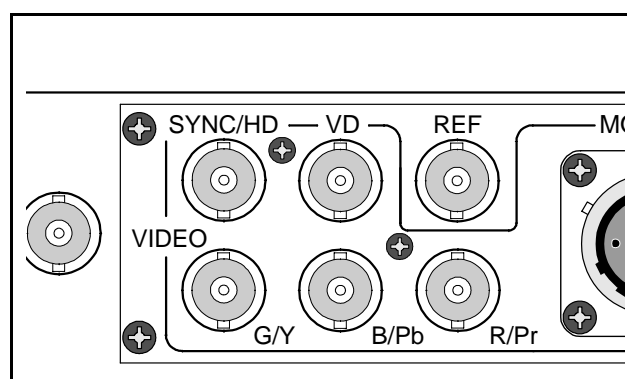

Installation

SETTING UP A MULTIPLE SUPERVISOR INSTALLATION

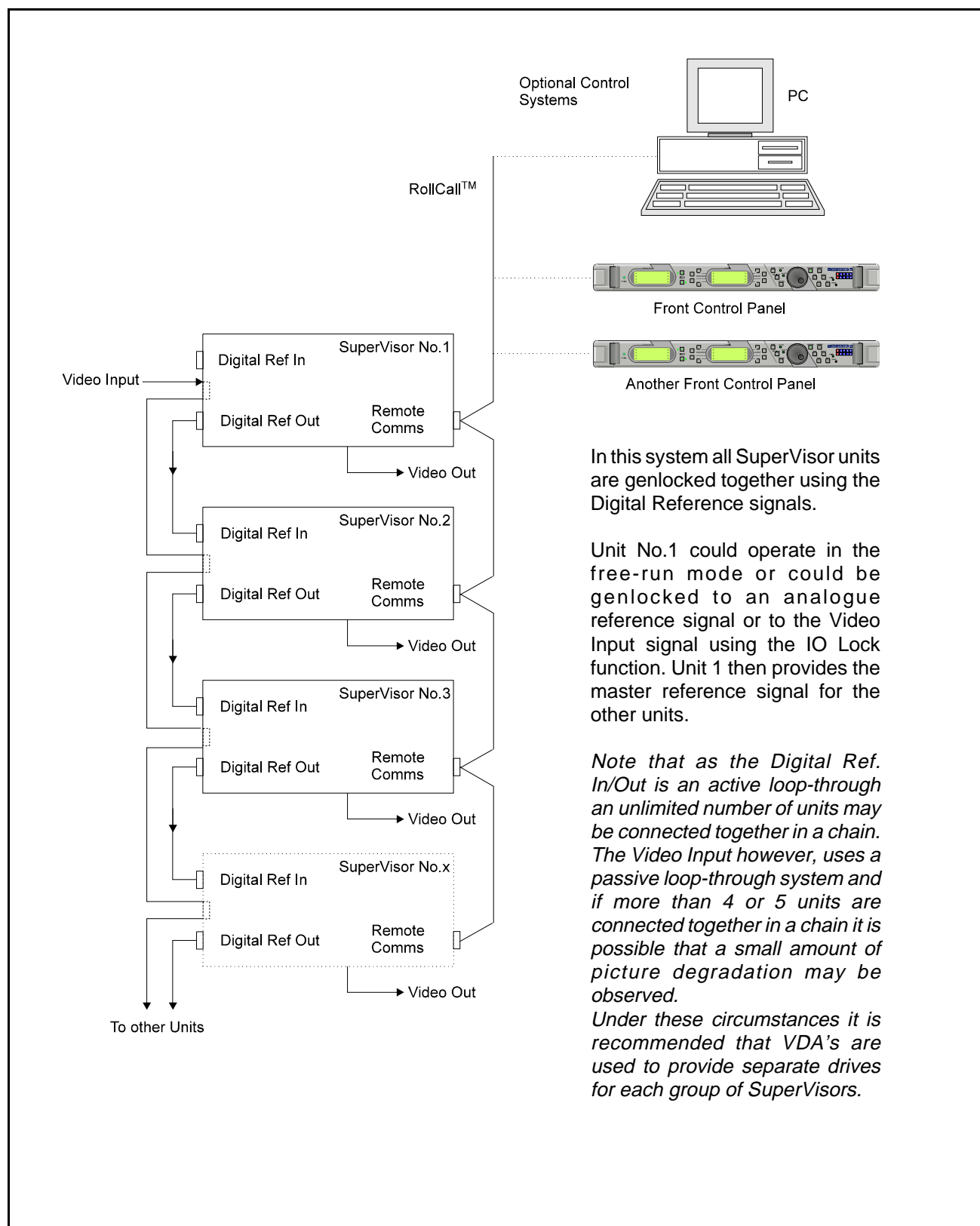

Installation

VGA KEYING WITH SUPERVISOR

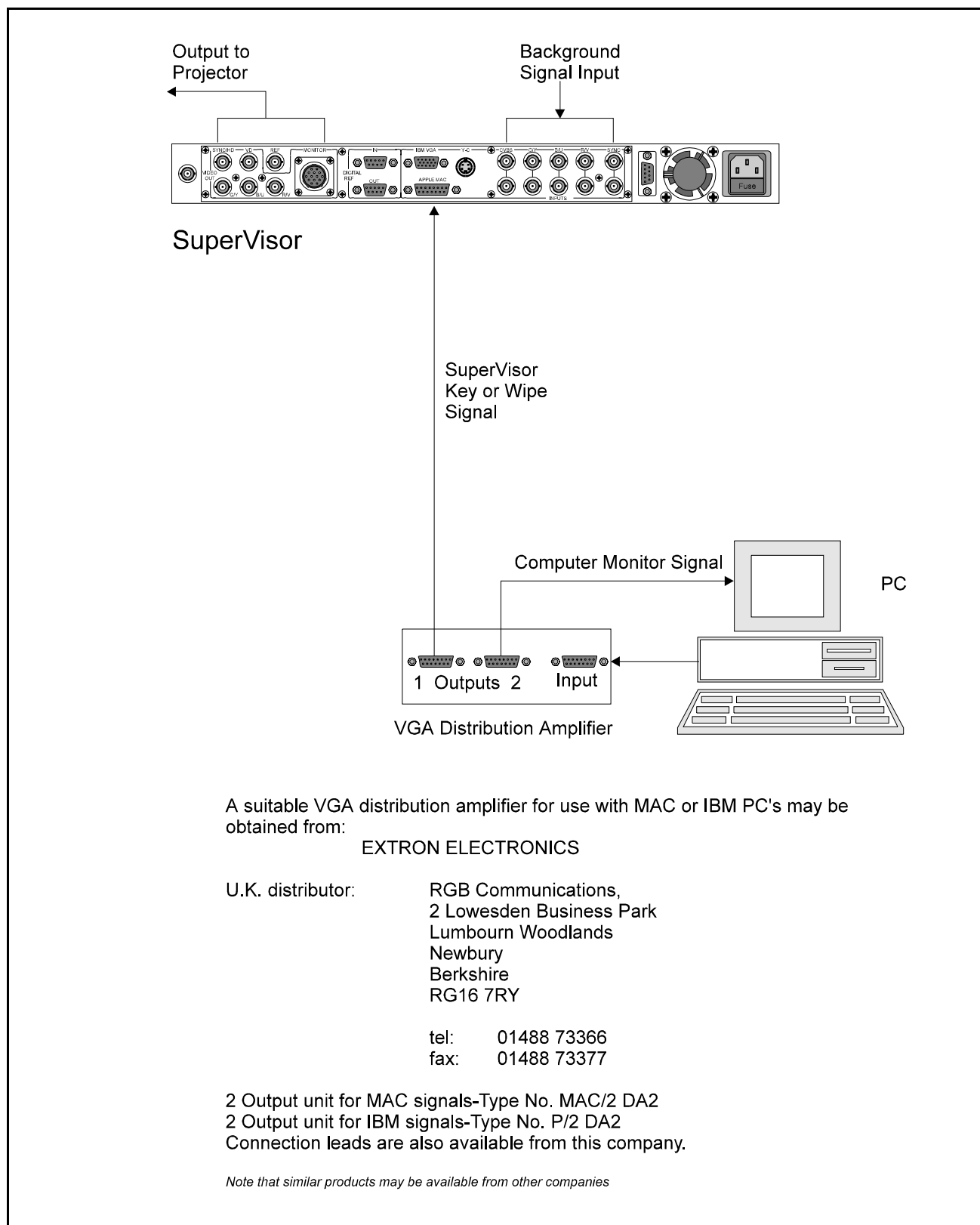

TIPS ON HOW TO USE YOUR SUPERVISOR

The Supervisor is a very versatile tool, it was conceived to enable Audio Visual professionals to improve or optimise video pictures for projection. This guide is intended to enable you not only to take advantage of the Supervisor's wide ranging capabilities, but also to achieve the best from the display device and picture sources that you have. Although throughout this guide we refer to projectors, the Supervisor will work with any display device, and most of the principles presented here are equally relevant to whatever technology is being used.

Please note that this is only a guide based on good video practice. To achieve the best results it will be necessary for all elements in the video chain to be working well. The lowest quality part of the chain will determine the final image quality, be that the original picture source, playback mechanism, projector, screen or projection environment. So use the guide to assist you to achieve ever better video pictures, that is after all what the Supervisor is all about.

Projector Types

There are several predominant projector technologies on the market, each type has advantages and disadvantages, and each type can have favourite settings for best results. The flexibility of Supervisor makes it possible to optimise these settings. Video projectors have in recent years become more flexible in line and field rate, often able to display HDTV and computer graphics in addition to regular video. It is important to choose the right projector for the job required, since there are many manufacturers of projectors on the market all promoting their various technologies.

CRT Projectors

CRT Projectors are available from many companies in a very wide range, they have been around the longest and come in three main categories.

Regular

525 and 625 inputs only, now only really used at the bottom end of the market. Often the lens quality is poor. N.B. This type will not work with Supervisor.

Multiscan

The current favourite, multi-scan projectors have a wide line and field rate range to allow use on computers as well as regular video. The difference in cost between the cheapest and most expensive is mostly in the optics and CRTs. Brightness is often traded for Sharpness or vice versa. CRTs are normally on the small side for best results with widescreen 16-9 pictures.

HDTV

Mostly considered too expensive but these are the best to use if possible. They may need stacking to increase the light output. HDTV projectors normally have large 9" or 12" tubes, magnetic focus (very important for sharp focus over the whole screen) and very good quality all glass or glass plastic hybrid lenses with liquid coupling for a higher contrast ratio. Most HDTV projectors are available with multi-scan facility but some have a scan frequency range limited by the magnetic focus.

CRT Projectors are amongst the easiest to install and have the lowest running cost. They are by far the most common type of video projector.

Oil Light Valves

These are professional projectors used for very large screens with a lot of light output. These are normally installed by professionals and are used a lot in NASA type control rooms. Often used at televised awards ceremonies or beside the stage at pop concerts. They are available in multi-scan and use special Anamorphic lenses for widescreen

ILA Lightvalve

ILA CRT/LCD projectors have been around many years in the large control room screen area. Recently improvements to the LCD dynamics have made them suitable for moving pictures. They have a lot of light output and can project onto a large screen. Black level on some models is not quite black. The gamma tracking is sometimes poor when the ILA bias is adjusted for minimum pattern visibility, the Supervisor gamma corrector allows the gamma to be brought back to normal.

LCD Lightvalve

The LCD lightvalve is the current hot shot although picture quality is very variable. In a few years time this will almost certainly be "The" technology until semiconductor mirror projectors become available.

Currently look out for low pixel count (low resolution), LCD lag or smear, not quite black black level, defective pixels, poor gamma tracking and beat patterns on moving pictures.

DMD (Digital Micromirror Device)

This is a new form of projector which uses reflective mirrors on a silicon chip to reflect the light beam through the output lens. They have great potential for the future, although at the time of writing only a few development models have been shown. One potential problem could be the visibility of grid lines caused by the gaps between the mirrors and a stepiness on smooth graduations, this aside the technology offers several advantages over some current projector types and is definitely one to watch.

Laser

Laser projectors are very specialist and are used for mainly long throw applications for very big screens or projecting on to, for instance, water fountains. They have almost infinite depth of field resulting in perfect focus on any object in the beams path.

As a guide please try the following Supervisor settings to start with. These settings should compliment the particular projector types, but we would always recommend experimentation since there are many factors that can affect perceived picture quality.

CRT Projectors	2 x H or 1.5 x H/1.5 x V.
Oil Light Valve	2 x V or 2 x H.
ILA Light Valve	Non Interlace or 2 x H.
LCD Light Valve	Depends on internal scan rate adapter. Experiment.

Where H = Number of scanning lines in the picture.

V = Number of pictures per second.

1-1 after the H and V number indicates non interlace or progressive scan.

2-1 after the H and V number indicates interlace.

Basic Issues of Projection

There are several important issues when deciding how to set up a projector. The two most important are viewing distance and contrast ratio (often confused with brightness).

Viewing Distance

The standard way throughout most of the world to describe projector size is to give a figure denoting the size of the projection diagonal in inches. The width and height for any diagonal size of the screen depends on the aspect ratio required.

The standard way to decide how far away from the screen to seat the audience is to multiply the screen height by a ratio dependent on the Video format used. In practical terms the screen height to audience position ratio depends on the resolution and quality of the original material and the scan rate used for projection. The simple guidelines below can be used as the minimum distance for good quality pictures. The minimum distances may be too close for audience comfort however.

Using 1050,1125 or 1250 lines the line structure will become visible at about 1.5-1.8 H. (H = screen height) e.g. Screen height 6 feet. Distance from screen to audience $6 \times 1.5 = 9\text{ft}$.

For super sharp digitally mastered HDTV pictures 2-2.5 H. For intermediate HD (Unihi Etc.) 3 - 3.5 H (Normal for HDTV viewing). For Low end HD or upconverted regular video 4 -4.5H. For regular video 8-8.5H.

Assuming the original picture quality is good, the only downside of being closer than optimum will be a loss of subjective sharpness. The further away the viewer the less will be the perception of quality or sharpness difference, although the viewing experience will be degraded.

Contrast Ratio

Contrast ratio is the difference between black and maximum white. The more contrast ratio the more "punch" and sharpness the picture will appear to have.

Nowadays most video projectors use cinema style screen material. This material commonly has a gain of around 2.25. This means it reflects 2.25 times more light than the reflection standard. (The reflection standard in the UK is a freshly cut magnesium block). Beware of screens with quoted gains of 5 plus. They will either use a dirty dish towel as reference or be designed for specialist application and be too directional.

The lower the gain of the screen the lower the light output. The higher gain screens have the advantage of a higher light output but have the disadvantage of a small viewing angle. (People at the sides or above and below the optimum position see a dimmer picture). The higher gain screens also suffer more from colour shading when used with projectors having separate Red, Green and Blue channels.

Getting back to contrast ratio, it is commonly perceived that the brighter the picture the greater the contrast ratio, this is only partly true. Contrast ratio is the ratio between Black and peak White.

It is extremely important to ensure that the blacks are black. Ambient light reduces contrast ratio severely, the higher the screen gain the more severe is the contrast degradation. There is little point in having a several kilowatt xenon lamp in the projector if the screen is washed by high ambient light and yet even the most experienced professionals make this mistake regularly. So unless physical conditions make it impossible such as at outdoor events, you should always carefully control the projection environment.

Set up tips

Mechanical Positioning

Projectors with colours coming from different origins need to have each colour overlaid one on the other. This is called convergence or registration.

Modern projectors have extensive remote controls with electronic correction to make this possible. There is however a down side. This is that the more electronic correction used in the scanning mechanism the more likely the registration is to drift. To minimise this drift the projector should be precisely aligned physically to the manufacturers specifications.

The simplest way to check the position of the projector for the correct horizontal axis is with a piece of cord. Tie an end of the cord to each side of the screen. Then tie a knot in the cord, so as to form a "V" with each leg of the V precisely the same length. The V cord is pulled back over the body of the projector until the legs of the V pass over the front left and right corner of the projector. Adjust the knot position until the cord crosses the projector corners as above.

The projector is now moved until it is dead centre with the screen and at 90 degrees to the screen horizontally. The knot forming the root of the V can be moved in or out for different projector screen distances. The vertical position should be checked with height measurements and an inclinometer. Following this mechanical adjustment the projectors mechanical focus should be adjusted as should any tube lens assembly adjustments, if the screen size has varied from the previous set up.

Electrical Set up

When adjusting the Set up electronically all "zone/area" correction should be erased or pre-set as should size.

Spend as much time as possible setting the projectors basic adjustments such as size, position, keystone and pincushion before moving to zone/area. If factory pre-set size does not match the screen try moving the projector in or out slightly.

With CRT projectors it is worth lowering the contrast and looking into the green lens to set the scan size as big as possible without distortion. Take great care when doing this as the tubes are very bright. Never do this with any other type of projector as eye damage may result.

All projectors need some warm up time before becoming stable. There is a combination of electronic and mechanical drift that takes maybe 1-2 hours to stabilise. Some CRT projectors have problems with electrostatic charge travel along the CRT's. This may take as much as 7 hours to stabilise, causing convergence drift.

If the power is interrupted the charge dissipates and the drift starts from the beginning. It is always worth putting the projector on a continuous supply and taping the connectors to stop cleaners unplugging the projector to plug in their vacuum cleaner, 10 minutes before your major client arrives.

If you are using an HDTV projector for the first time it is easy to stop optimising the line up when it looks a bit better than a normal projector. You will find however that it is well worth spending more time, as true HDTV projectors can look awesome.

Picture Set up

Picture set up is often carried out carelessly or not optimised for the programme material to be shown. Using the above guide and Supervisors wide selection of test patterns it is possible to get the best out of the picture source. Below is a suggested procedure for set up and alignment.

Set the Output rate to that which will best compliment the display device. If using the computer keying features then this output will be limited to the computer rate that is used.

Select Patterns on. Select the Crosshatch pattern from the Patterns menu. Using this pattern or else the projectors in built convergence patterns, correctly converge the projector. The usual sequence is to start with the green gun as near to its centre default position as possible, then to converge red to green, then blue to green. Whilst doing this it may be a good idea to turn the brightness and contrast down so that the crosshatch patterns appear as fine lines.

Set the Gamma adjustment to 0, this is in the Filtering menu, Select Pluge pattern from the Patterns menu. The Pluge pattern has two important vertical bars in the left part of the picture. The left vertical bar is just above black level and the right vertical bar is just below black level. Adjust the projector brightness until the left bar is visible and the right bar is just invisible. You may wish to set up the picture slightly to adjust the colour and then reset. It is extremely important that this adjustment is made in the conditions you will project in. The top white bar of the vertical grey scale should not be blooming.

Select Step (Gamma) pattern in the Patterns menu and adjust projector contrast until the right hand bar blooms or has a halo effect. Turn the contrast down until the bloom or halo just disappears. Check if the steps of the pattern appear to be equal or if they appear to be too close together at the left side (the well known black crushing). Adjust the Gamma control (Filtering menu) until the steps appear to be equal.

This Step (Gamma) pattern should also appear as a neutral grey, so adjust the individual gun set-ups to achieve neutral greys on the lower LHS steps and the individual gun gains to achieve neutral whites on the higher RHS steps. This neutrality test can also be done using the Ramp pattern, and then selecting Mono in the Effects menu to give a smoothly increasing video level from black to white.

Select the multiburst chart and check for good resolution, this will help to confirm if the convergence is correct.

Finally check the colourimetry with the Bars, and Bars with Red patterns, remembering that these give 100% colour saturation, which is unlikely to be achieved by any video source, but may be achieved by a computer source.

It is possible to trade sharpness for brightness (contrast control) on CRT type projectors with RGB drive and Contrast controls. If it is decided to run the projector at a higher brightness (contrast control) then reference should be made to the above patterns to see what effect this will have on flare, blooming and colourimetry. Somewhat confusingly the brightness control adjusts the black level of the picture and the contrast control adjusts the peak brightness.

Now the projector is correctly aligned to the Supervisor output. Errors in picture levels must now be at the input to Supervisor, so turn Patterns off and select the video source in the In Format menu. Run all the tapes or pictures sources and adjust the Procamp controls; Luma gain, Chroma gain, black level etc. to get the best pictures. These settings can then be stored in the Supervisor memories and recalled for each tape segment using the Save and Read keys. It is extremely important that as much as possible of this set-up is done in the same conditions as you will project in.

Tape Formats

Different tape formats have different attributes, noisy or consumer tape format programmes are best avoided for professional presentations.

Below is a list of videotape formats applicable to upconversion in order of preference

D1/D5
Digital Betacam
Betacam/MII
D2/D3
Type B/C/Quad
S-VHS/Hi-8 Y/C connected
U-Matic
VHS

Undoubtedly the best results come from component recordings and then the use of component throughout the chain. Next in order of preference would be to use Y-C connections, and then finally composite.

DVD Players

Commercial DVD material may be copy-protected. Your DVD supplier can tell you if the DVD material can be supplied without copy protection. DVD material that is not copy protected is the best type of DVD source for the Supervisor. If you do use copy protected DVD s you will find that the output picture may experience problems resulting in picture tearing as the DVD copy protection does its job.

With a little care and thought and using the above tips you should be able to achieve the best results from your equipment and picture sources.

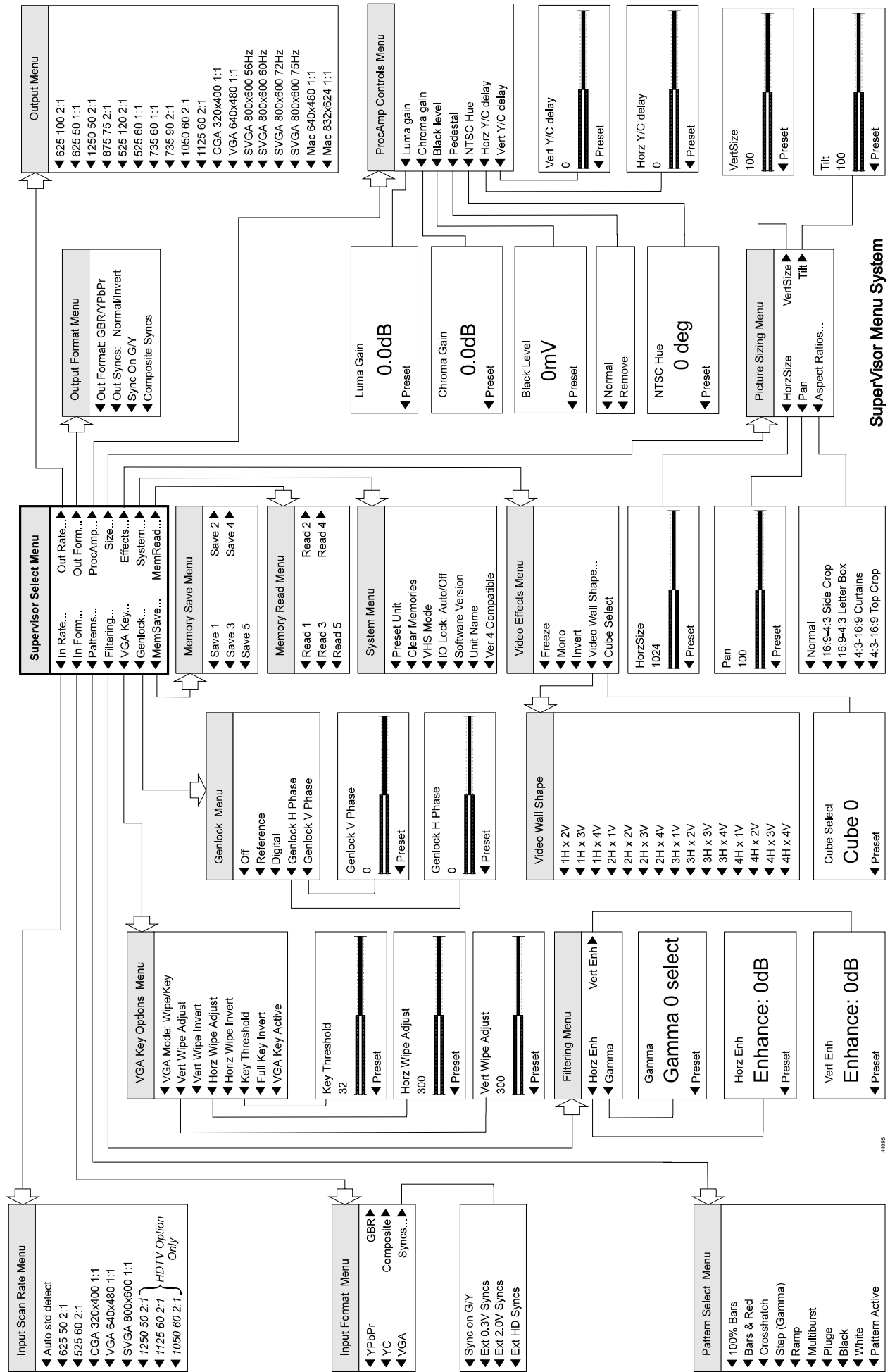

Operation

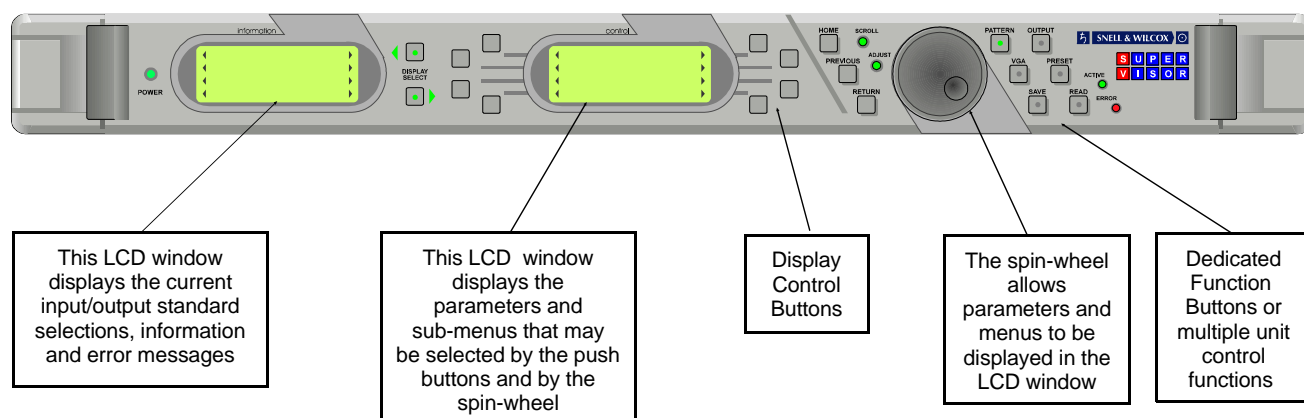

FRONT PANEL CONTROLS

GENERAL INFORMATION

The SUPERVISOR may be controlled by means of a local, front control panel, by a similar panel at a remote location or a computer interface. Communication is via a wired network system and several units may be controlled.

VGA Terminology

The term 'VGA' is used throughout SuperVisor documentation and in this context is used to describe all supported computer standards including CGA (Colour Graphics Adapter), VGA (Video Graphics Adapter), SVGA (Super Video Graphics Adapter) and MAC (Apple Macintosh) computers emulating VGA scan rates.

THE CONTROL PANEL

All operational parameters and selections are made using a system of menus displayed in two LCD windows. These are labeled INFORMATION and CONTROL.

Menus are selected by push buttons and further menu selections made by rotating a spinwheel and pressing a push button.

The spinwheel also allows continuously variable parameters, e.g. Luma Gain, to be adjusted and the setting to be seen in the LCD window.

The **Display Select** buttons allow the spinwheel action to be applied to either the Information or the Control window.

Various specific operations may be achieved by operating dedicated push buttons.

The Menu System

(See 'Supervisor Menu System' drawings opposite)

The system may be considered structured as a set of menus and sub-menus which are displayed in the central LCD window. The **Information** window will display the current input/output standard selections of the unit and information messages. (e.g. Signal Loss, Genlock Loss)

The highest level menu is called the **Select Menu** and contains the names of the lower-level menus which may be scrolled through using the spinwheel.

The sub-menu may then be selected by pressing the push button adjacent to the arrowhead in the text line of the menu name. This sub-menu will then be displayed in the window and will have the option of selecting another sub-menu in the same manner, or allow the adjustment of a particular parameter. Parameters enabled will appear as highlighted reverse text (white text on a black background)

Operation

3-LEVEL MENU SYSTEM

Uniquely, the SuperVisor has three menu systems available to the operator.

The menu system at **Engineering** and **SuperVisor** level contains all available SuperVisor functions and the system at **User** level contains a simplified set of functions optimised for easy every-day operation.

These menu systems are shown opposite page 5.1

Selecting the Menu Level

- 1 Power-down the SuperVisor unit
- 2 Hold down the SAVE button, power-up the unit then release the SAVE button. (Note that the menus will only be loaded when the button is released)
- 3 When the menus have been loaded press the SAVE button.
A front panel menu will appear in the control window instead of the SAVE menu and the information window will display **Setup Options**
- 4 Select ACCESS LEVEL from the menu

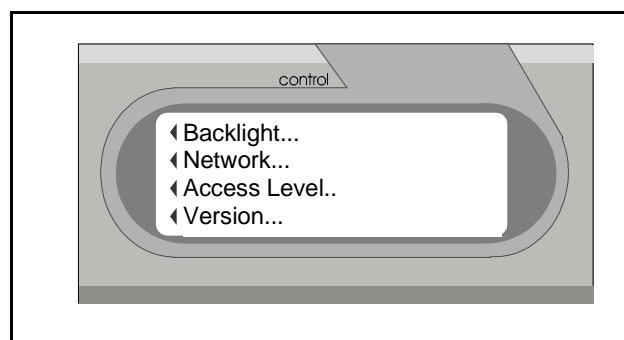

CAUTION!

Do not attempt to select or change any other settings in the front panel menu.

- 5 By rotating the spinwheel select either the **Engineer** or **User** setting from the displayed sub-menu
- 6 Save this setting
- 7 Power-down and power-up the unit; the front panel will now offer the new set of menus

USING THE DIFFERENT LEVELS

The **Engineering** level should be used to set up basic parameters of the unit that would not be available in the **User** level.

e.g. Input Scan Rate, Output Format, Genlock Functions etc.

When these parameters have been set up the **User** level can be accessed and the new menus used to control a simplified set of functions.

Operation

GENERAL INFORMATION

If a menu title is followed by three dots

e.g. **Genlock...**

this indicates that a further sub-menu is available for selection.

Pressing the **Home** button will display the **Select Menu** in the control window from any position in the menu hierarchy.

The **Previous** button allows a return to the last menu that was *changed*. Up to 20 changed menus may be retraced using this function.

The **Return** button will allow access to the previously selected upper-level menu.

When the **Scroll** LED is illuminated this indicates that a menu contains more than four text lines and the spinwheel may be used to scroll through the menu. When the **Adjust** LED is illuminated this indicates that parameter values and alpha-numerics may be changed.

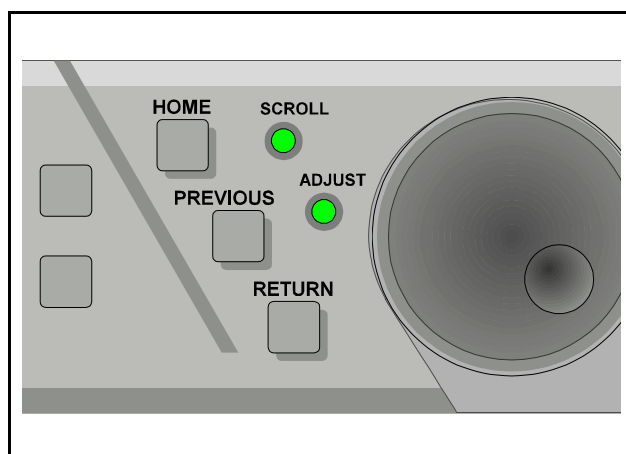

Operation

THE LCD DISPLAY WINDOWS

Control Window

The control window displays all Selection Menus and sub-menus. An example is shown opposite.

The selection is made by pressing the button adjacent to the required item and will become highlighted (reverse text) when active.

Information Window

The information window has four lines of text indicating current selections and various messages.

The first line shows the current selection made from the Input Scan Rate Menu or the currently selected output pattern.

The second line shows the current selection made from the Output Standard Menu.

The third and fourth line displays information and error messages.

The example opposite indicates that the selected input standard is 625 line, 50Hz field rate, interlaced 2:1 the selected output standard is 875 line 75Hz field rate, interlaced 2:1 and that the unit is not receiving an input signal .

The window may display the following error messages:

Freeze-SYNC LOSS

This indicates that the unit is not receiving an input signal or that the input signal sync level is below 100mV p-p

-- GENLOCK LOSS --

This indicates that the unit is not receiving a reference input signal or that the reference input signal sync level is below 100mV p-p

Note that if both input and reference signals are lost the SYNC LOSS message will have priority and will be displayed.

Information messages such as -- Preset -- will appear in the third line when the function is selected but will only be displayed for approximately 5-10 seconds. If an error condition exists the error message will then be displayed; otherwise the line will become blank.

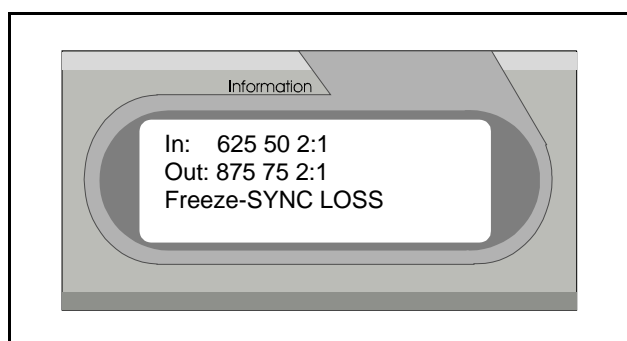
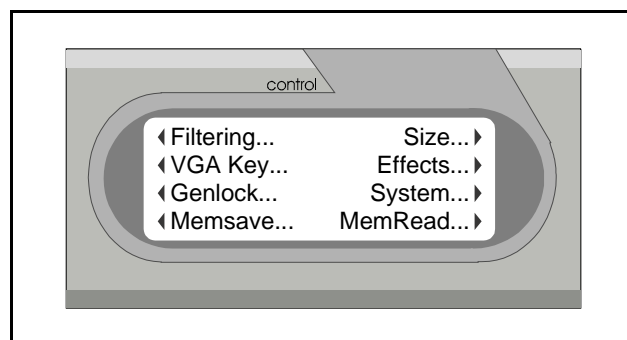

Operation

Example....Menu Selection

USING THE MENU SYSTEM

This example describes how to select the input and output rate and then change the output picture width (Horizontal Size) using the menu system.

An input signal with a scan rate of 625 lines, 50Hz interlaced 2:1 is assumed, driving a suitable multi-monitor at a scan rate of 625 lines, 50Hz, non-interlaced.

Ensure that the **Select Menu** is shown in the control window. If not press the return button until the menu is shown.

Rotate the spinwheel, if necessary, to reveal the **In Rate...** text line.

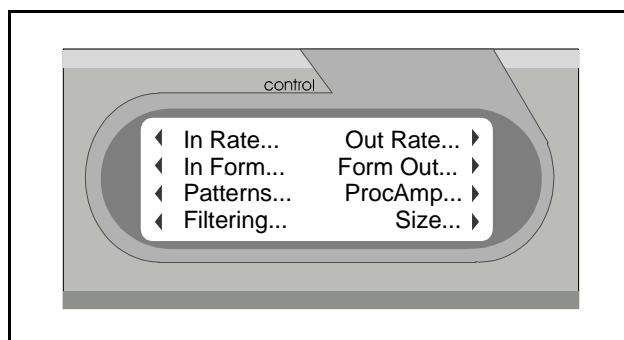

Press the button next to **In Rate...** to reveal the Input Scan Rate Menu.

Rotate the spinwheel, if necessary, to agree with the drawing opposite.

Select either **Auto std detect** or **625 50 2:1**

Press the return button to return to the Select Menu.

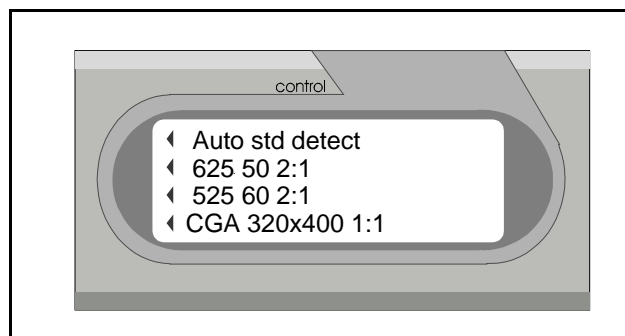

Operation

From this menu select **Out Rate...** and the Output Scan Rate menu will be displayed.

Rotate the spinwheel, if necessary, to reveal the **625 50 1:1** text line and press the adjacent button.

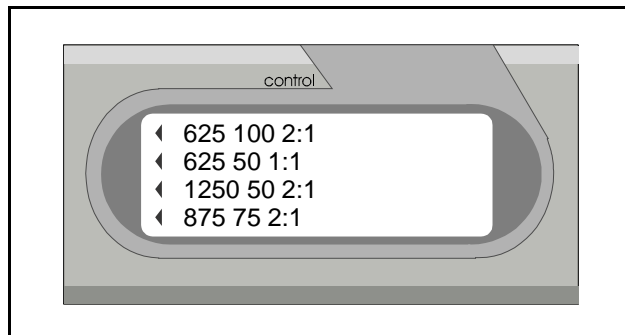

Ensure that the information display window now shows the units system status as shown opposite.

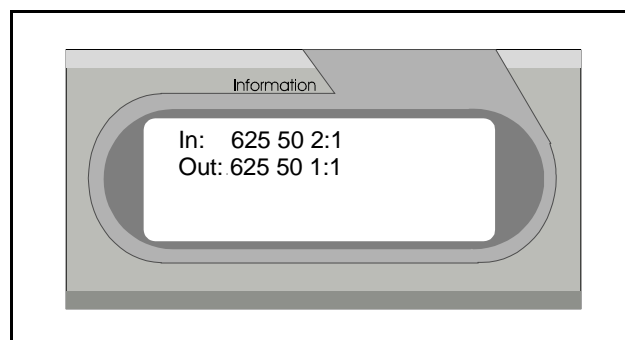

Rotate the spinwheel to reveal the **Size...** text line in the select menu and press the adjacent button.

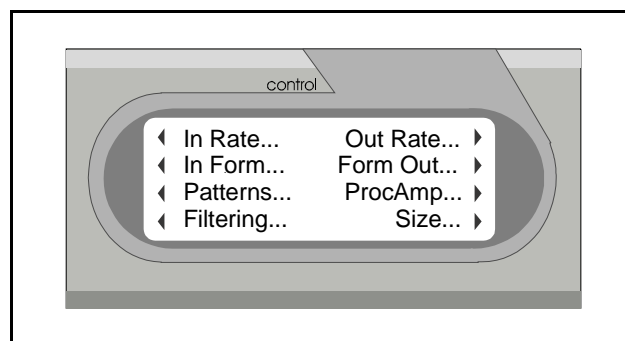

This will reveal the Picture Sizing Menu.

Press the button adjacent to **Horz Size**

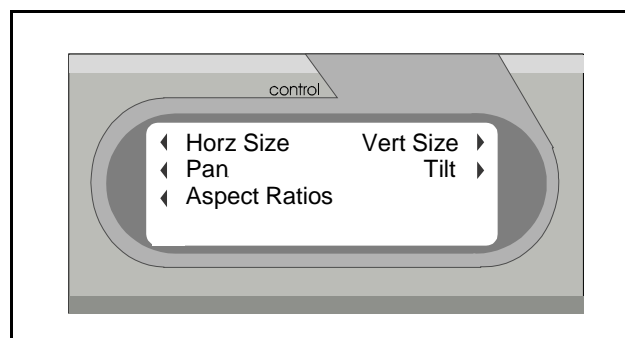

Operation

Example....Menu Selection

The control window will now display a bar-graph showing the current Horizontal Size setting.

The horizontal size of the output picture may then be changed to the desired value by rotating the spinwheel.

To return to the previously set value, the button adjacent to the Preset arrowhead should be pressed.

This completes the example demonstrating the use of the menu system.

Pressing the return button will return the central display to the Picture Sizing Menu and pressing it again will return the display to the Select Menu.

All other functions and parameters may be selected in a similar manner.

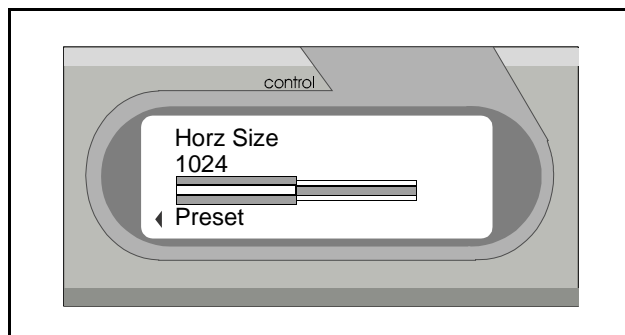

Operation

USING THE DEDICATED PUSH BUTTONS

Various specific operations may be carried out by using these push buttons which provide a short-cut method to access particular functions.

When pressed the button LED will become illuminated, indicating that the function is active. Pressing the button again deactivates the function and the button LED will turn off.

Selecting a Pattern

Pressing the PATTERN button will display in the window the currently selected pattern from the list of test patterns in the **Pattern** menu. (see 'TEST PATTERN SELECTION')

Pressing the button again deactivates the function, and the processed picture will reappear.

Note that if a pattern has already been selected using the menu system the words PICTURE ACTIVE will appear in the window. Either method may be used to select a pattern but using the dedicated button is a more direct method.

Short-Cut to Selecting the Output Scan Rate Menu

Pressing the OUTPUT button will immediately reveal the **Out Rate...** menu in the control window. Selections may then be made in the usual way. (see 'OUTPUT SIGNAL SCAN RATE')

Pressing the button again deactivates the function and the top level **Select Menu** will appear in the display window.

Short-Cut to Selecting the Memory Functions

Pressing the SAVE button reveals the **Mem Save** menu in the control window, listing the five memory locations. (see 'MEMORY')

Pressing the READ button reveals the **Mem Read** menu in the control window, listing the five memory locations. (see 'MEMORY')

Pressing the buttons again deactivates the function and the top level **Select Menu** will appear in the display window.

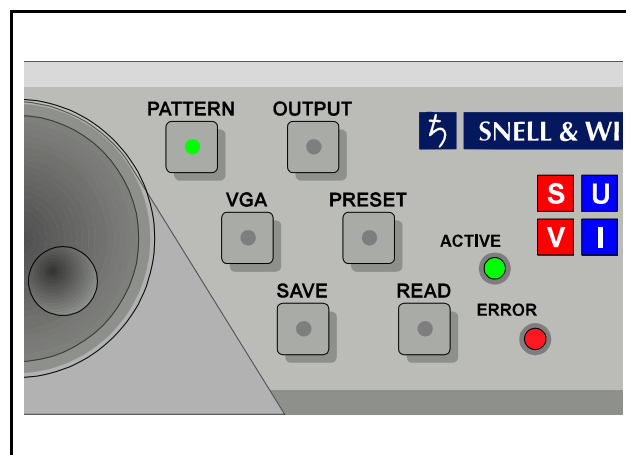

VGA

The **VGA Key or Cut** function as specified in the VGA Key Menu, is toggled ON or OFF with this button. This has the same function as selecting VGA KEY ACTIVE in the VGA Key Menu.

Note that if a VGA Output Scan Rate has not been selected, the VGA key function will not be available and the message 'Select Video→VGA' will appear in the information window.

Preset

Pressing the PRESET button will return the unit and all settings to a preset condition. The preset conditions will be the factory default settings *except* where the default settings have been changed by the DIP switch SW3.

*Note that this is **not a reset function** and all stored memory information will be retained.*

This function is particularly useful for a first-time user or when the user is uncertain of a previous user's set-up; returning to a preset condition provides an ideal starting point for configuring the unit to one's own preferences.

Operation

Note that underlined menu items are only available at **Engineering** and **SuperVisor** levels. Text in brackets refers to equivalent item (if available) in **User** level

MENU DETAILS

INPUT SIGNAL SCAN RATE

Pressing the button adjacent to the In Rate... arrowhead in the Select menu will access a list of input scan rates.

The first option is for **Auto std detect**.

Selecting this option will allow the unit to automatically sense the input signal standard and process it accordingly.

The unit may be forced to accept a particular input signal scan rate by scrolling through the menu using the spinwheel and pressing selecting the required scan rate.

Default setting is **Auto std detect** (this message will appear in the left hand window)

*Note that if the unit is **forced** to accept a particular input scan rate, e.g. 625 50 2:1, and subsequently the input signal changes to , for example, 525 60 2:1, the output signal will become corrupted. If such changes of the input signal scan rate are anticipated it is suggested that the **Auto std detect**. mode be selected.*

When in the **Auto std detect** mode the information window will show the standard of the input signal scan rate. For example if a 625 signal is connected the display will show:

Auto - 625

This information is purely dependent on the the input signal and is automatically detected.

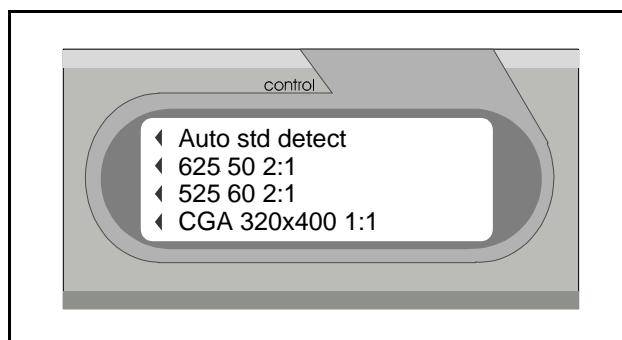
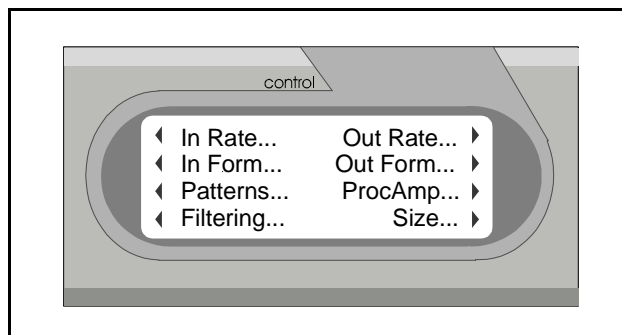

Operation

OUTPUT SIGNAL SCAN RATE

Selecting Out Rate... (**Output**) in the Select menu will access a list of output scan rates.

The unit can be made to produce a particular output signal scan rate by scrolling through the menu using the spinwheel and selecting the required scan rate.

Producing The Best Quality Pictures

The quality of the final displayed picture can depend on a number of factors:

- 1 Input to output scan rate compatibility
- 2 The actual output scan rate chosen
- 3 The *particular* characteristics of the display unit
- 4 Adjustment of the processing controls
- 5 The type of material contained in the picture

Input To Output Scan Rate Compatibility

Best results will generally be achieved by choosing an output scan rate complimentary to the input scan rate. For example, if a user required a greater number of lines in the output picture (to reduce scan line visibility) a scan rate of 1250 lines would be chosen to give best results when the input scan rate was 625 lines rather than 1050 lines, which would be used with a 525 line input. Generally, select the highest output scan rate that is an integer multiple of the input scan rate.

The Particular Characteristics Of The Display Unit

All display devices, especially projection systems, have their own particular and often unique, characteristics.

The SuperVisor has a wide range of output scan rates available in many formats and it is well worthwhile spending some time experimenting with various combinations of output scan rate and format.

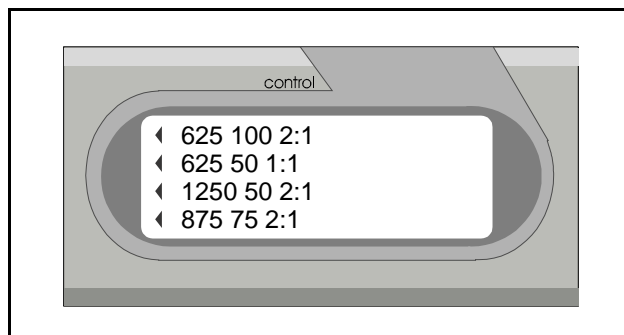

Adjustment Of The Processing Controls

Optimising the Luma Gain, Chroma Gain, Black Level, Y-C timing, Gamma and Sharpness adjustments can dramatically improve the displaced picture; again, experimentation is advised.

The Type of Material Contained in the Picture

Specific programme material may benefit from the use of particular interlace ratios and line rates; experimentation is also advised for a particular application.

Operation

INPUT SIGNAL FORMAT

Selecting In Form... (**Input**) in the Select menu will access a list of input signal formats.

A particular input format and a Syncs sub-menu may be selected from this list.

It should be noted that the YPbPr and GBR input connections share the same BNC connectors on the rear panel, whereas the composite, YC and VGA inputs have dedicated separate connectors.

Note that if an input signal is not present or the sync level is below 100mV, the information display window will show

Freeze- Sync Loss

and the unit will have automatically enabled the freeze mode and captured the last previous source picture.

Note that the syncs options applies only to the component GBR and YPbPr input signals.

Selecting Syncs... reveals a list of input sync options. The default selection is **Sync on G/Y** indicating that the unit is set up to accept either a GBR signal that has syncs on the green channel or a YPbPr signal with syncs on the Y channel.

Selecting **Ext 0.3V Syncs** allows the unit to accept an input sync level of 0.3V p-p (nominal) at the SYNC input connector.

Selecting **Ext 2.0V Syncs** allows the unit to accept an input sync level of 2V p-p (nominal) at the SYNC input connector.

HDTV Option

If the HDTV input option is fitted the **Ext HD Sync** item will appear in this menu.

When this item is selected and HDTV signals are being processed, the GREEN signal (which contains the Tri-Sync signal) should be bridged through the G/Y input connectors and connected to the self-terminating REF input.

Note that when this selection is made any sync signals connected to the SYNC or G/Y connector will be ignored.

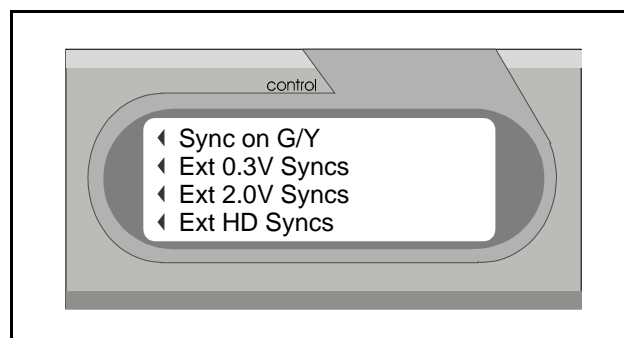
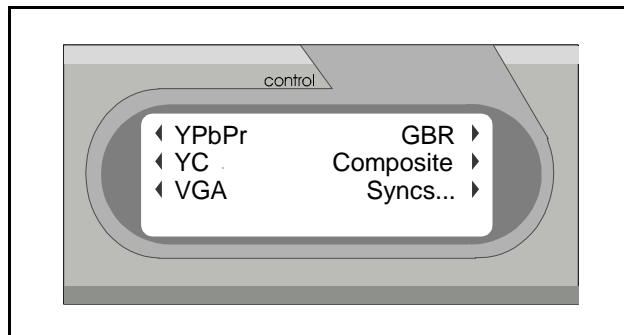

Operation

OUTPUT SIGNAL FORMAT

Selecting **Out Form..** in the **Select** menu will access a list of output formats.

The first text line allows either a component YPbPr or GBR output format to be selected. Default selection is to GBR.

Note that the YPbPr and GBR output connections share the same BNC connectors on the rear panel whereas the Monitor output has a dedicated separate connector.

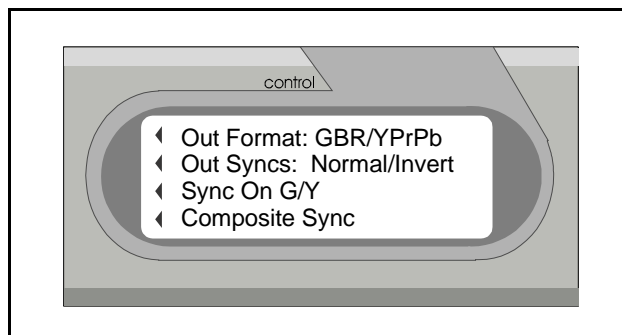

Output Signal Details

YPbPr Mixed syncs may be added to the Y signal using this menu (see below) and to the Pb and Pr signals by means of an internal link LK5

GBR Mixed syncs may be added to the Green signal using this menu (see below) and to the Blue and Red signals by means of an internal link LK5

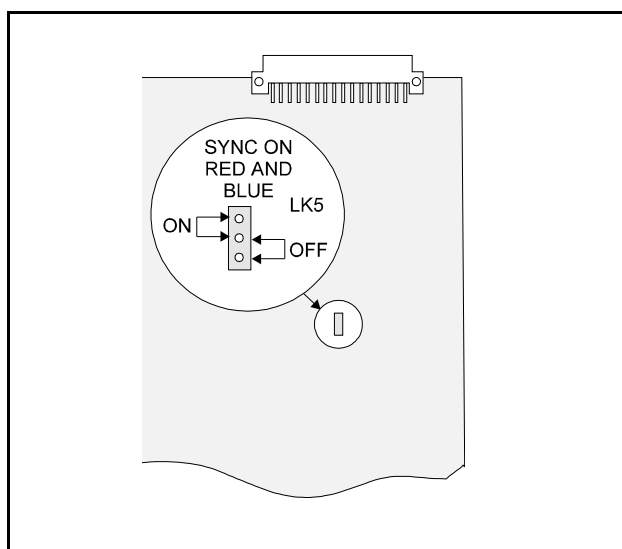

Location of Jumper Link LK5

Operation

The second text line, **Out Syncs**, allows the sync polarity to be set to either Normal or Inverted. Default is to Normal.

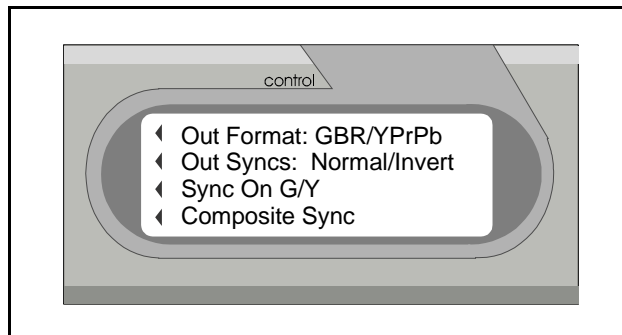
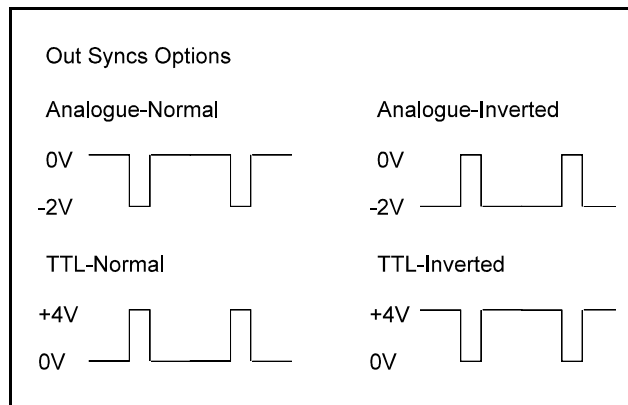

The type of output is set using jumper links LK2 and LK3 on the PCB and may be set to give an analogue signal (0 to -2V into 75 Ohms) or a TTL compatible signal (0 to 4V into 1K Ohms)

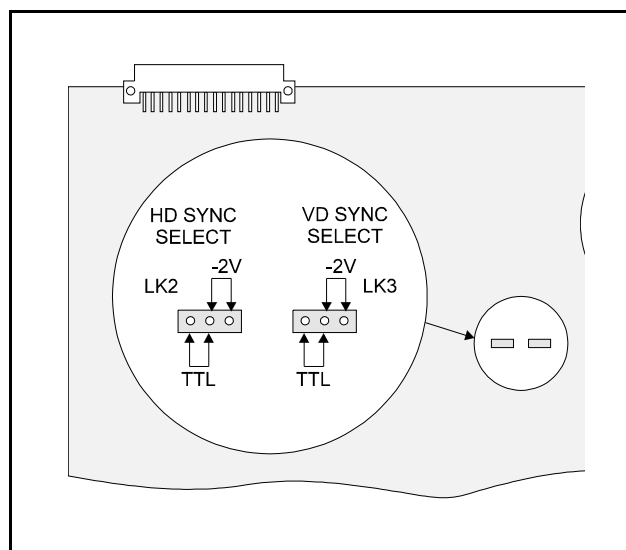

Location of Jumper Links LK2 and LK3

The next text line, **Sync On G/Y**, allows the sync signal on the Green or Y signal (0.3V p-p) to be turned On or Off. Default selection is to Off.

The last text line, **Composite Sync**, selects the type of signal available at the Sync/HD connector on the rear panel. The 'On' selection produces a mixed sync signal and the 'Off' selection produces an HD signal at this connector. Default selection is to Off.

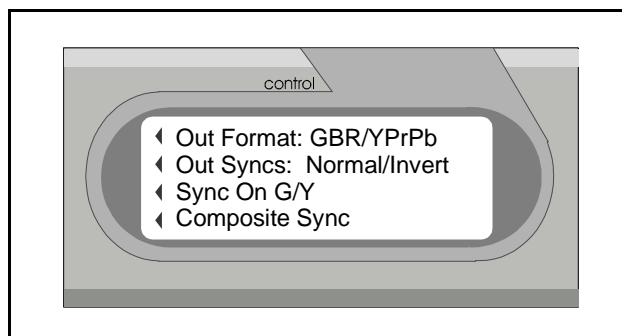

Operation

TEST PATTERN SELECTION

Selecting **Pattern...** in the Select menu will access a list of test patterns available from the unit.

The **Pattern** mode selection may also be enabled by pressing the dedicated front panel button marked 'Pattern'. The pattern will then immediately appear at the output and the pattern name and 'pattern active' will become highlighted in the menu.

A particular pattern may then be found and selected. The pattern name will then become highlighted. To output the pattern the 'Pattern Active' line should be selected and the text will become highlighted. To de-select a pattern the 'Pattern Active' line should be selected and the text will revert to normal.

When a pattern has been selected the first text line in the information display window will show:
Pat: (pattern name) instead of In: (input standard)

The pattern will have parameters as selected in the Output Scan Rate and Output Format menus.

Note that the Size, Pan, Aspect Ratio and invert functions cannot be applied to the internally generated patterns.

Patterns include:

Colour Bars	(100%) For checking Colourimetry and Alignment
Bars and Red	(100% Bars and 100% Red area) For checking vertical Y/C delay
Crosshatch Step	For checking registration (10 equal steps) For checking the Gamma setup.
Ramp	(0 to 100%) For checking linearity. (Note that this signal includes a UV ramp which may be removed by selecting the Mono function in the Effects Menu)
Multiburst	(2,4,6,8,10,12,14 and 16MHz bursts) For checking frequency response
Pluge	For checking black level (brightness) and gain (contrast)
Black	(0%) For checking black level errors.
White	(100%) For checking white level.

Note that for patterns containing vertical information (Bars and Red, Crosshatch and Pluge) the relative proportions of the vertical areas will vary slightly depending on the output standard in use.

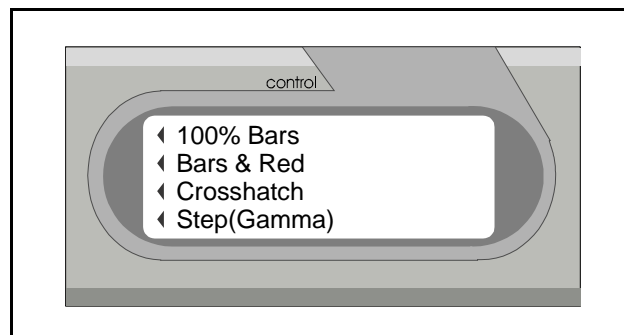

Operation

PROCESSING CONTROLS

Selecting ProcAmp... (**Video**) in the Select menu will access a list of signal processing functions that may be controlled. Note that these settings will effect ALL video output signals where appropriate.

When a function is selected the unit will provide a display giving the name of the parameter, the numerical value and the facility to return to a preset value. The value may be adjusted using the spinwheel within the limits stated in Section 2, 'Specifications'

Pedestal

The SuperVisor will automatically, by default, only remove the pedestal present on 525 line Composite and Y-C signals.

Note that to comply with SMPTE 170M the pedestal of 525 line YPbPr signals will not be removed automatically.

The **Pedestal** selection provides the facility to override this automatic function by selecting '**Remove**'. The default selection is '**Normal**'

It should be noted that if an input scan rate/format other than 525/Composite/Y-C is selected, the input signal pedestal, (if any) will be retained on the output signal when the '**Normal**' selection is made.

CAUTION!

If the '**Remove**' option is enabled under these conditions, and the input signal has no pedestal, the black level of the output signal will be set-down.

Horizontal and Vertical Y/C Delay

Selecting **H-YC Delay** or **V-YC Delay** will reveal a numeric display allowing horizontal or vertical Luma to chroma delay adjustments to be made using the spinwheel.

NTSC Hue (if Decoder option fitted) (NTSC Tint)

Selecting NTSC Hue will reveal a numeric display (in degrees) allowing the hue or colour tint of an NTSC picture to be adjusted by $\pm 20^\circ$

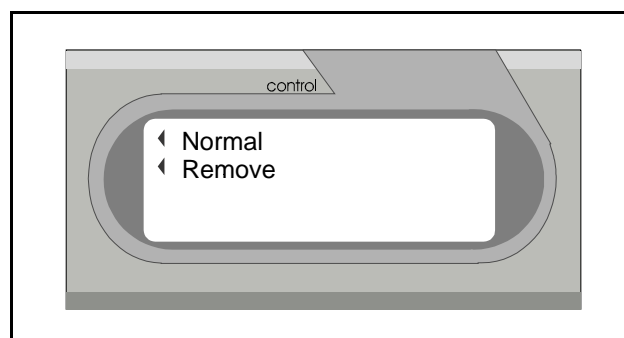
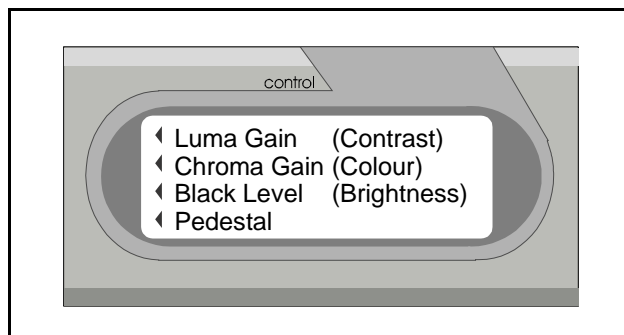

Operation

FILTERING

Selecting **Filtering...** in the Select menu will access a menu offering the choice of filtering and Gamma characteristics.

The signal passing through the unit may be sharpened in both the horizontal and vertical directions by means of aperture correctors and Gamma correction may be applied to the signal.

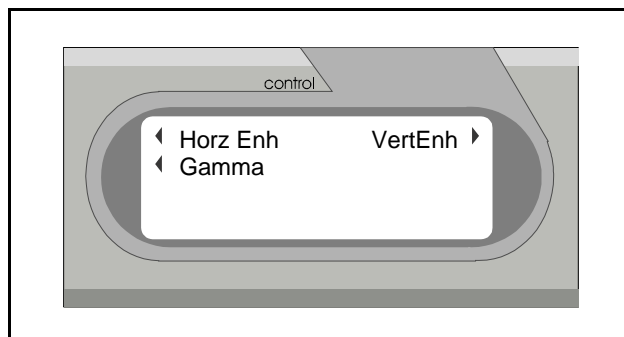

Selecting the characteristic required to be adjusted will provide a display giving the name of the parameter, the numerical value and the facility to return to a preset value.

The value may be adjusted using the spinwheel within the limits stated in Section 2, 'Specifications'

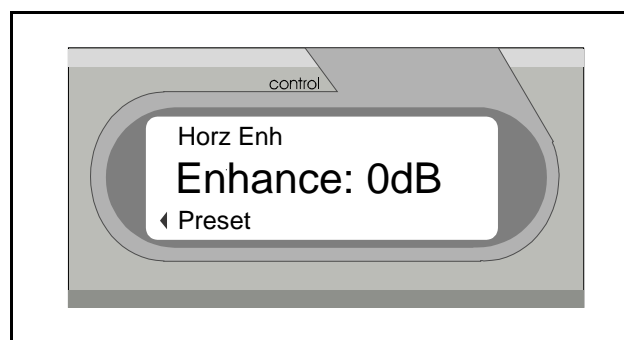

Operation

Gamma

Selecting this option will reveal a numeric display titled Gamma showing the amount of gamma correction (expressed as a number) and the facility to return to a preset value.

The value may be adjusted using the spinwheel to give various values of black stretch.

In this context Gamma is defined as the shape of the transfer characteristic between input signal amplitude and output signal amplitude. Normally the shape is a straight line with a slope of unity and the output level follows the input level over the dynamic range of the signal. i.e. Gain does not change with signal level.

If the shape of the transfer characteristic is changed to a curve, gain will then change with signal level and can be arranged to either stretch black parts of the signal and compress white parts or stretch white parts and compress black parts of the signal.

Generally the output level is related to the input level by the equation

$$V_o = V_{in}^{\gamma}$$

Where γ = Gamma Value

The Gamma correction values available from this unit range from 1 (unity) to 0.55 in nine equidistant steps and is only applied to the Y (Luminance) signal. An example of the effects of gamma correction is shown opposite.

This function is particularly useful for correcting the non-standard Gamma characteristics of CRT-type large screen projectors.

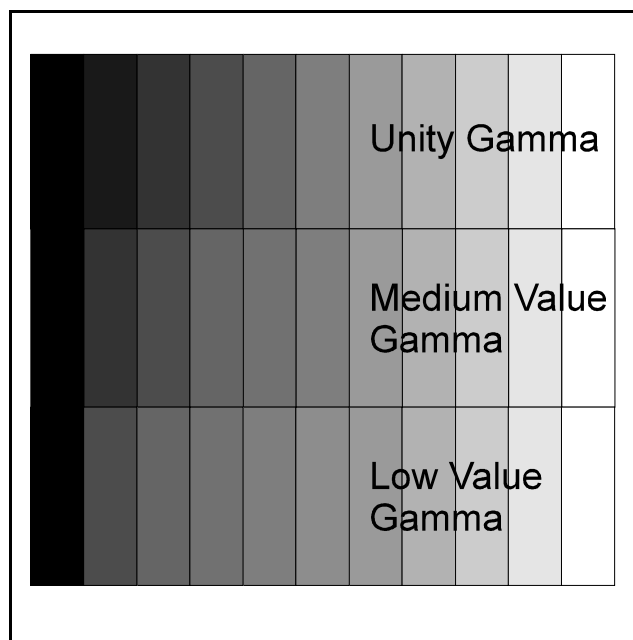

Operation

OUTPUT PICTURE SIZE

Selecting Size... in the Select menu will access a Picture Sizing Menu offering the opportunity to change the size and shape of the picture.

Picture at 1:1 Size

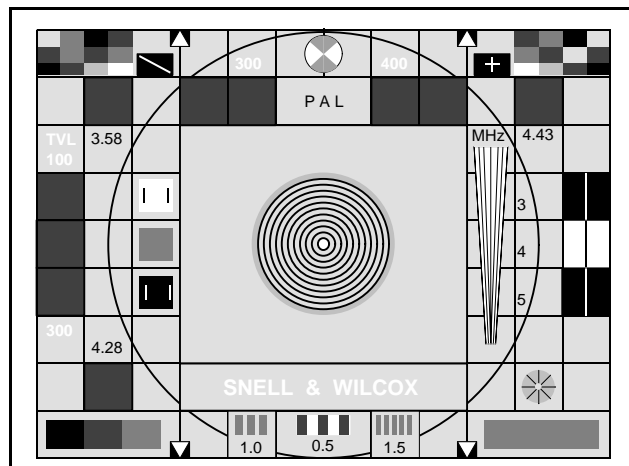

Selecting **Horz Size** invokes a bargraph display indicating the relative width of the output picture compared to the input picture.

The width may be reduced by 1.5:1 (as shown opposite) or increased by 4:1 (as shown below) using the spinwheel, in steps of approximately 5%. The **Preset** and default value is 1:1

Note that the bargraph is provided to indicate the relative reduction (clear bar reduces in length) or increase (clear bar increases in length) in picture width from the 1:1 value.

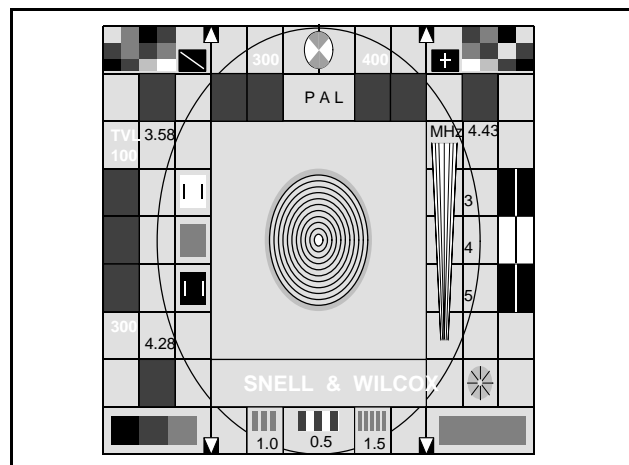

The **Vert Size** selection allows the height of the output picture to be changed in a similar way to the width, as described above.

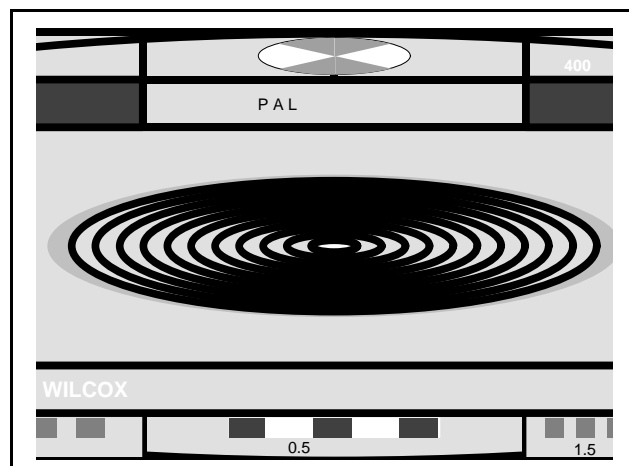

Operation

PICTURE PAN AND TILT

When, for example, a particular section of the picture is required to be placed in a particular area of the screen the PAN or TILT function may be used.

Note that the Pan/Tilt function is only operational when the picture size has been changed (increased or decreased) from the 1:1 value; the picture may then be moved horizontally or vertically (within the picture boundaries) to any position on the screen.

The **Pan** selection allows the picture to be panned horizontally by $\pm 75\%$ of input picture width, in steps of $<100\text{ns}$.

Picture Size x2 with maximum Pan Left

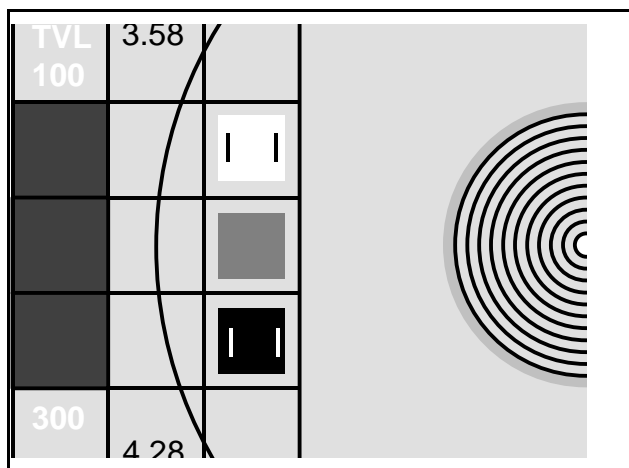

Picture Size x2 with maximum Pan Right

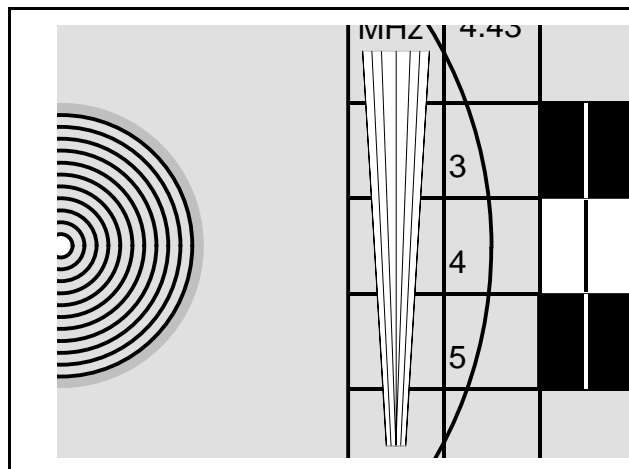

Picture Size ± 1.5 with maximum Pan Left

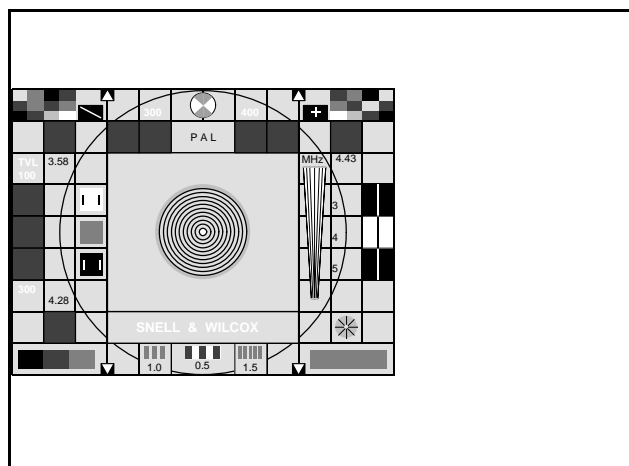

Operation

PICTURE PAN AND TILT cont.

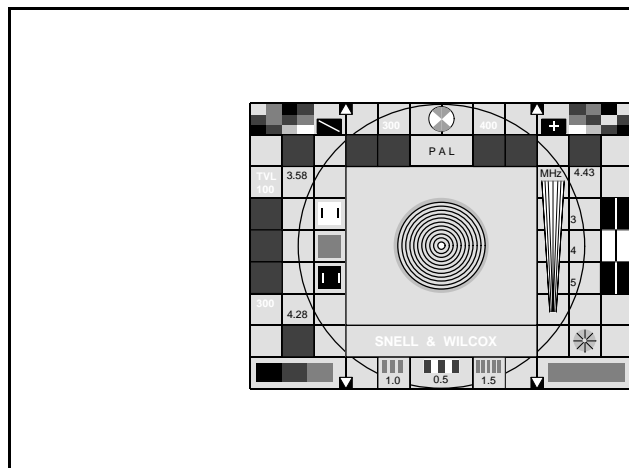

Picture Size ± 1.5 with maximum Pan Right

The **Tilt** selection allows the picture to be vertically panned by $\pm 75\%$ of input picture height, in steps of 2 input picture lines.

The bargraph indicates the type and amount of TILT (clear bar reduces in length for negative values and increases in length for positive values)

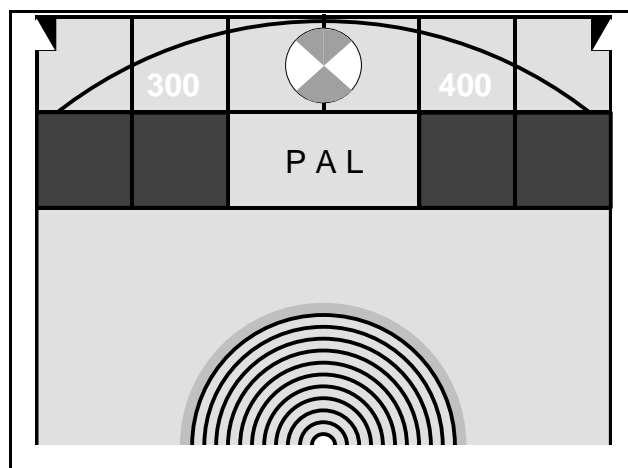

Picture Size x2 with maximum Tilt Up

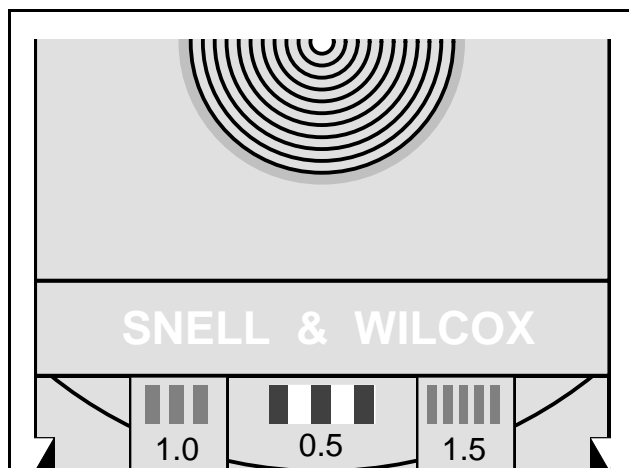

Picture Size x2 with maximum Tilt Down

Operation

PICTURE PAN AND TILT cont.

Picture Size ± 1.5 with maximum Tilt Up

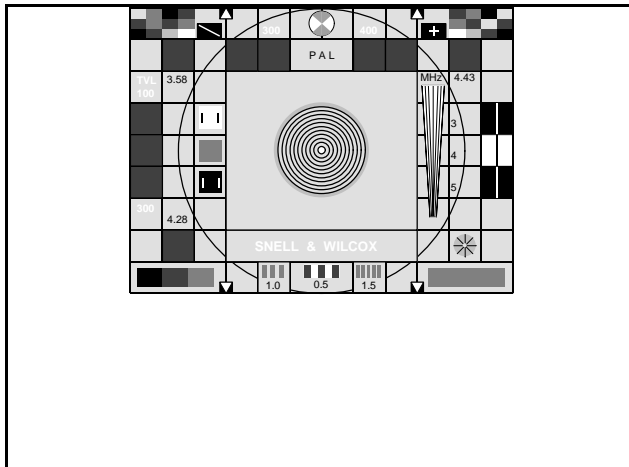

Picture Size ± 1.5 with maximum Tilt Down

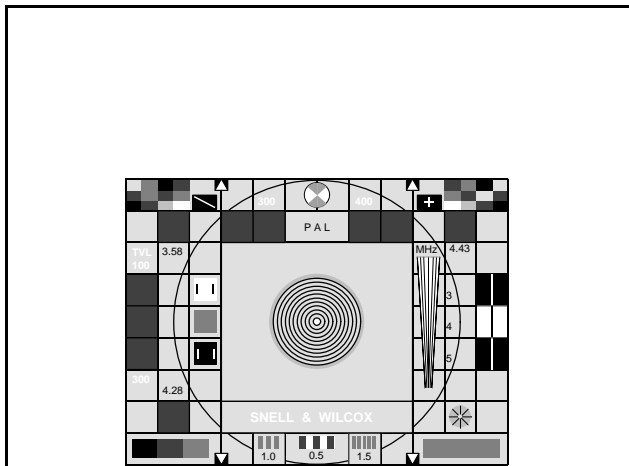

Operation

OUTPUT PICTURE ASPECT RATIO

The output picture may be displayed with a different aspect ratio to that of the input picture.

Selecting the **Aspect Ratios** option in the Picture Sizing Menu allows various input/output aspect ratios to be selected from a menu. The selected ratio will become highlighted in the menu so long as no changes have been made to the picture size or a Pan/Tilt adjustment introduced.

Note that the Size, Pan/Tilt and Aspect Ratio functions cannot be applied to the internally generated patterns.

Normal will give the same output aspect ratio as the input

16:9 Aspect Ratio Picture

16:9-4:3 Side Crop will give an output picture aspect ratio of 4:3 when the input aspect ratio is 16:9. Some picture information will be lost on both sides.

16:9-4:3 Letterbox will give an output picture aspect ratio of 4:3 when the input aspect ratio is 16:9. Black bars will appear at the top and bottom of the picture but no picture information will be lost.

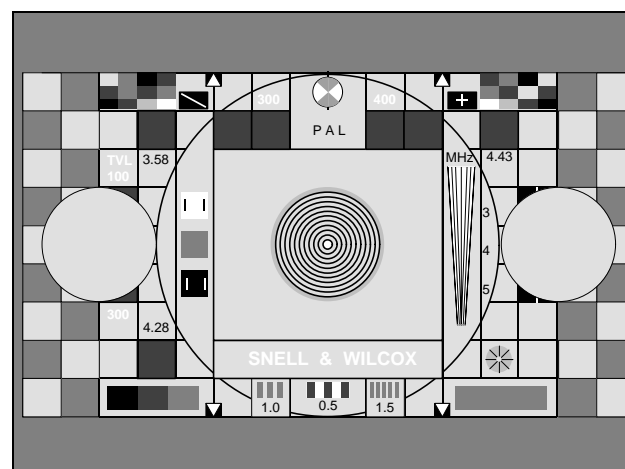
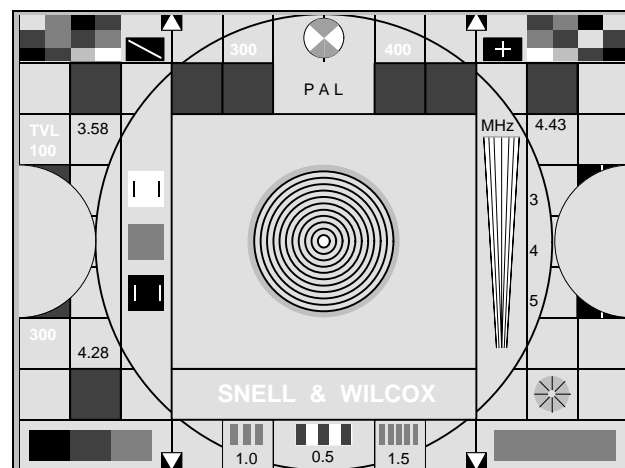
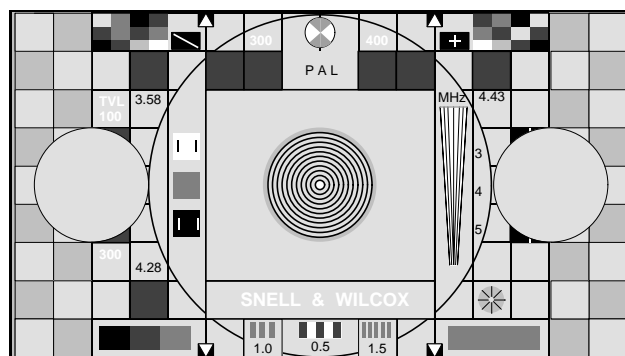

Operation

OUTPUT PICTURE ASPECT RATIO

4:3 Aspect Ratio Picture

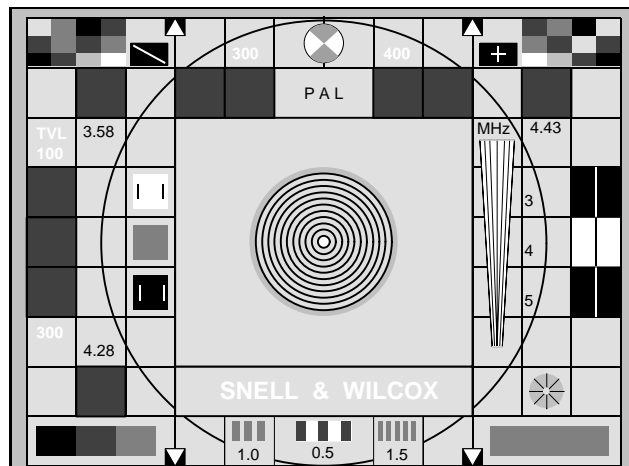

4:3-16:9 Curtain will give an output picture aspect ratio of 16:9 when the input aspect ratio is 4:3. Black bars will appear at the sides of the picture but no picture information will be lost.

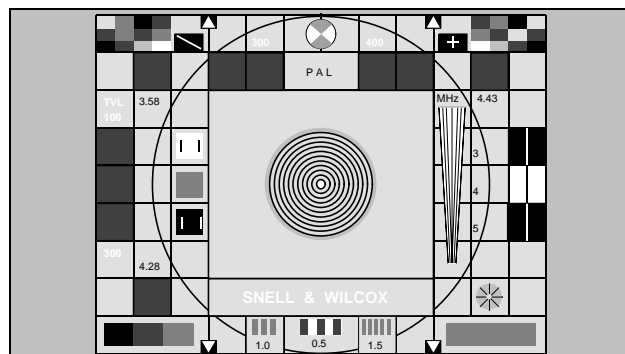

4:3-16:9 Top Crop will give an output picture aspect ratio of 16:9 when the input aspect ratio is 4:3. Some picture information will be lost at the top and bottom of the picture.

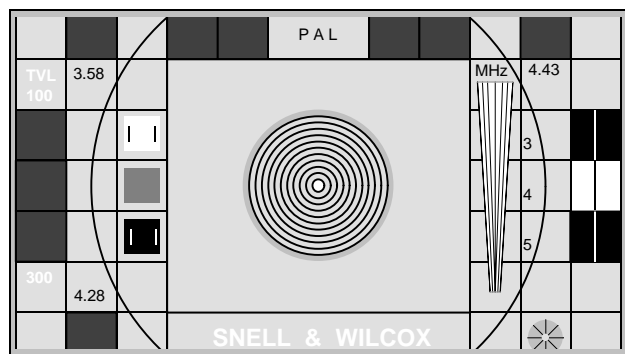

Operation

KEYING

This unit will allow a VGA or MAC signal (see 'Installation' page 3.4 for connection details) to be keyed over an analogue video signal.

Note that 'VGA' is used here as a generalised term for describing a signal derived from a computer source and includes CGA, VGA, SVGA and MAC type signals.

Keying is only possible when all of the following conditions are fulfilled:

1. The output scan rate is set to the same standard as the VGA input signal connected to the VGA INPUT (see Output Scan Rate Menu) *Note that this means that keyed pictures are only available in a VGA output format.*
2. A YPbPr, GBR, YC or Composite signal is selected (see Input Format Menu) DO NOT select the VGA option from the Input Format Menu.
3. A VGA signal is connected to the VGA input connector. The unit is designed to automatically genlock to this signal when any of the active VGA Key Options are selected (see VGA Key Options Menu) and will override the Genlock On/Off function in the Genlock Menu. *Note that the unit will remain genlocked to the VGA signal (even when the active VGA Key Options are de-selected) until either the output standard is changed (the unit then reverts to the previous genlock selection) or the genlock function is turned off.*

SELECTING THE KEY FUNCTION

The Key function may be directly selected by pressing the dedicated button on the front panel (toggles Key ON or OFF) or from the VGA Key menu and selecting 'VGA Key Active'

SETTING UP THE KEY PARAMETERS

When the VGA Key... option is selected from the **Select Menu**, the **VGA Key Options** Menu will be revealed.

The options are: VGA MODE: WIPE OR KEY

Wipe (to deselect, select **Key**)

When **Wipe** is selected output picture may be split into two sections; one section will contain the analogue picture and the other section will contain the VGA picture. The size and position of the section may be adjusted vertically and horizontally using two **Wipe Adjust** and **Wipe Invert** functions selected from the menu.

Key (to deselect, select **Wipe**)

This function keys the VGA picture into the analogue picture. The key signal is derived from the VGA picture by summing the red, green and blue signals and then passed to a threshold detector.

When this signal is above a particular level the VGA picture is displayed and when the signal is below that level the analogue picture is displayed. The level at which the change occurs is set by the Key Threshold control.

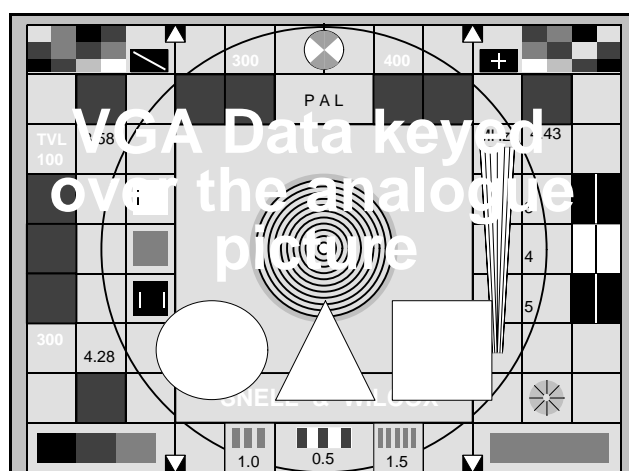

Operation

Vert Wipe Adjust

Selecting this function will reveal a bargraph showing the position of the vertical split point separating the two picture sources. This split point may be adjusted so that either more or less of either picture, in the vertical direction, is revealed.

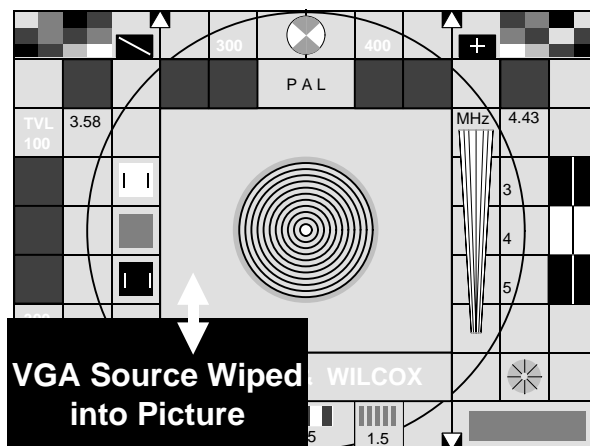

Horiz Wipe Adjust

Selecting this function will reveal a bargraph showing the position of the horizontal split point separating the two picture sources. This split point may be adjusted so that either more or less of either picture, in the horizontal direction, is revealed.

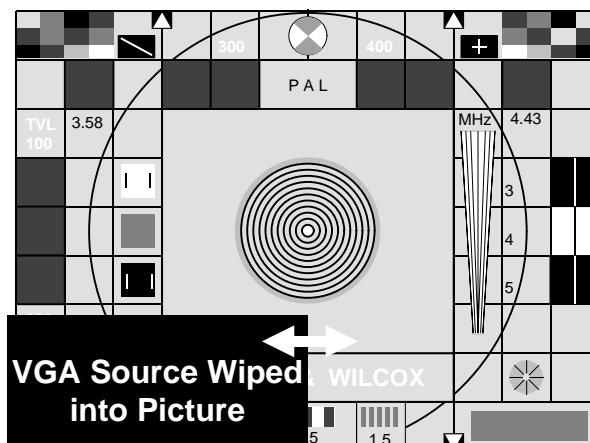

Vert Wipe Invert

When this function is enabled the area of the wiped-in picture, in the vertical direction, is changed from the lower part of the main picture to the upper part of the main picture.

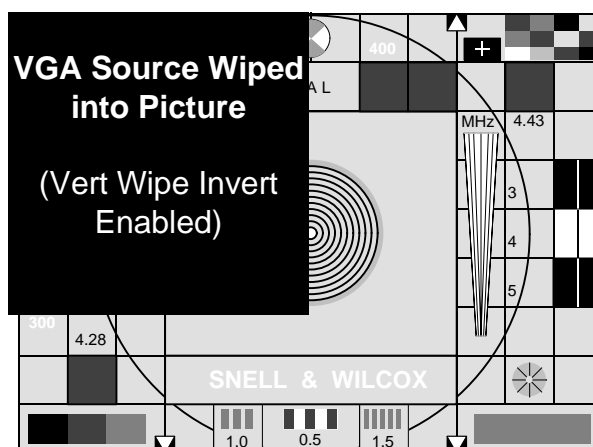

Operation

Horz Wipe Invert

When this function is enabled the area of the wiped-in picture, in the horizontal direction, is changed from the left hand side of the main picture to the right hand side part of the main picture

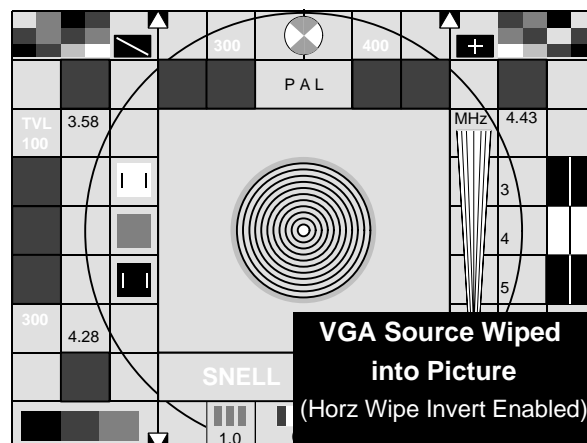

Key Threshold

Selecting this function will reveal a bargraph showing the level of the key signal that is used to determine the point at which the decision is to display either the VGA picture or the analogue picture.

The preset default level is set at 50% and can varied between 0 and 100%

Note that as the key signal is derived from a summed G+B+R signal, keying from individual colours is not possible.

Full Key Invert

In both **Wipe** and **Key** modes this function reverses the areas occupied by the VGA and the analogue picture. In the Wipe mode for example, in the picture opposite, the VGA source would now occupy the major part of the screen and the analogue source will occupy the minor part of the screen. In the Key mode, high levels of VGA signal will now reveal the analogue picture.

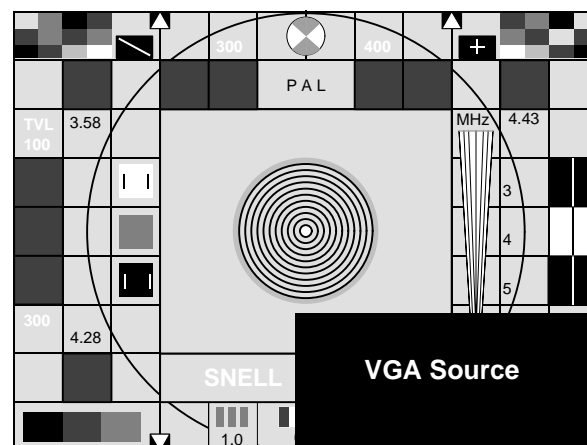

When the **Key** or **Wipe** function is enabled it may be toggled between On and Off by using the dedicated front panel button marked 'VGA'

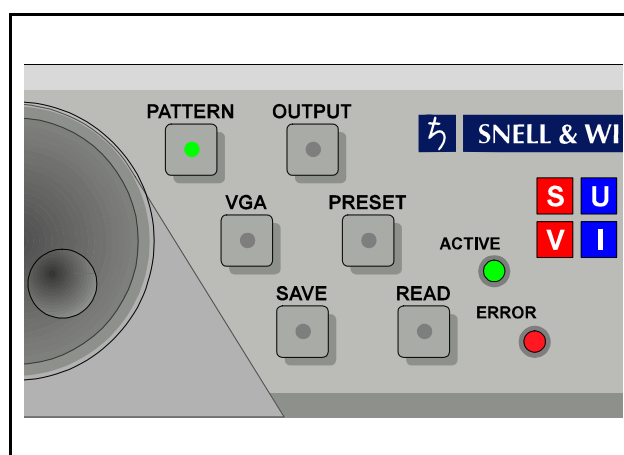

Operation

EFFECTS

Selecting Effects... in the Select menu will access a Video Effects Menu listing various effects that may be applied to the output picture. The functions may be toggled ON or OFF.

Freeze will produce a frozen picture.

Mono Turning this function ON will remove all colour from the output signal producing a pure monochrome picture.

Invert When this function is turned ON the polarity of the video signal is changed from positive to negative. i.e. Black becomes white and white becomes black.

Video Wall Shape

Selecting this function enables the SuperVisor to be used as a single channel video wall cube controller.

The image from the unit may then be divided amongst multiple projectors or other display devices which make up a very large screen display system.

The Video Wall Shape menu lists the various wall shapes that may be accommodated by SuperVisor.

Examples of the numbering format are given opposite:

One SuperVisor will drive a single cube (a cube is a individual projector or display device)

First the relevant **Wall Shape** should be selected and then the **Cube Select** menu should be selected.

The value set in this menu determines which cube the particular SuperVisor unit is controlling.

*Note that the 'Cube 0' selection (Preset value) is used when **only one** display device is to be driven.*

If a cube identification number other than zero is set in this menu the unit will automatically size the image to suit the wall shape defined in the **Wall Shape** menu. Fine picture alignment adjustments may then be made, if required, using the picture sizing controls (e.g. Size, Pan and Tilt)

Note that if a new Wall Shape is selected the Cube Ident number must be changed to suit the new shape.

For more information on multiple systems refer to SECTION 3, INSTALLATION.

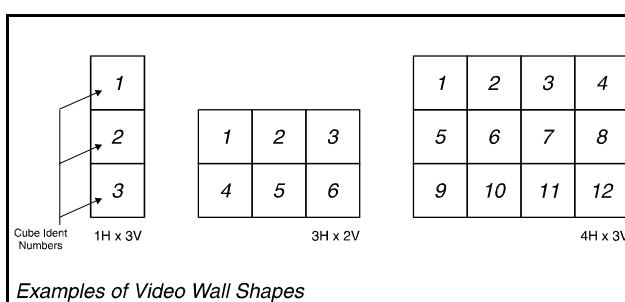
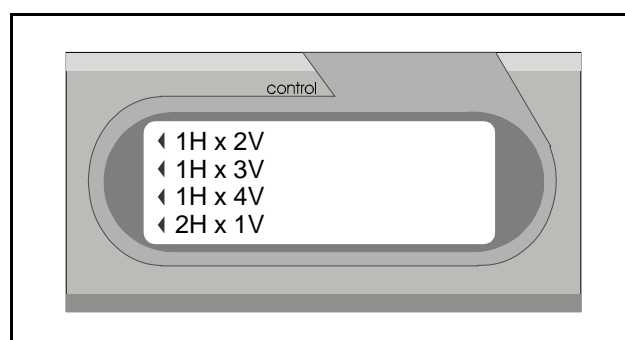
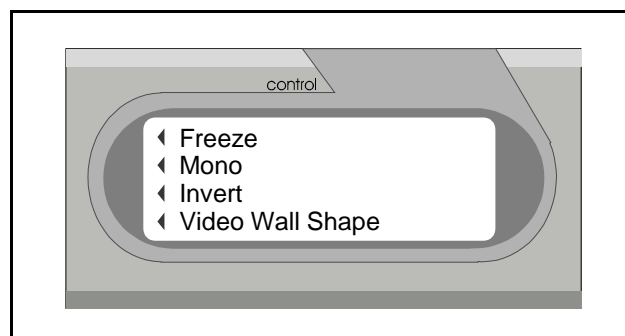

Examples of Video Wall Shapes

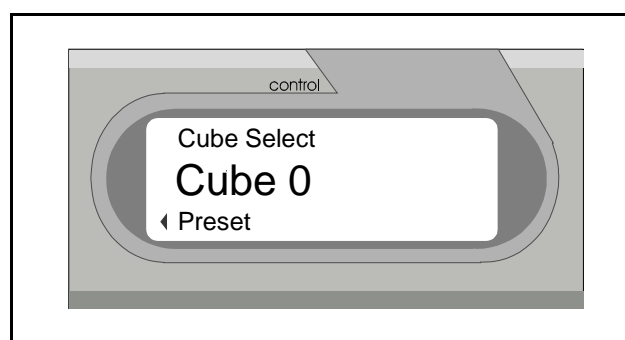

Operation

GENLOCK

The unit can genlock to either an analogue video/black burst signal (see note below), a digital signal or a VGA input.

Selecting **Genlock...** in the Select menu will access a menu listing various genlock options.

Off Selecting Off disables the genlock function and the unit free-runs using the internal SPG; however, when a VGA Key mode is selected the unit is forced to genlock to the VGA input. (see 'KEYING')

GLK

Whenever the genlock mode has been enabled the information display window will show GLK in the lower right hand corner. It should be noted that this indication does not necessarily mean that the unit is genlocked to a reference signal; it only indicates that the **genlock mode** has been **enabled**.

Reference When this mode is selected the unit will genlock to an external reference signal subject to the following conditions:

1. The unit will automatically genlock to the reference input appropriate to the selected Output Scan Rate. In practice this means that for most output scan rates the genlock reference signal will be derived from the Analogue Reference input connector but when VGA type output scan rates are selected (especially when the VGA Key function is enabled) the genlock reference signal will be derived from the VGA input connector.

2. The unit will genlock to the reference input only if the selected Output Scan Rate is compatible with the reference signal; if this condition is not met a corrupted or blank picture will be displayed.

3. If the HDTV Input option is fitted and the Ext HD Sync item selected, the REF input becomes the SYNC input, processing the Tri-Syncs contained in the HD GREEN signal.

Note that currently this analogue input does not support higher rate line and field signals. For such signals, e.g. from another SuperVisor unit, the Digital reference input should be used.

Digital Selecting this mode forces the unit to genlock to the H-Sync and V-Sync TTL signals from the 'Digital Reference In' connector.

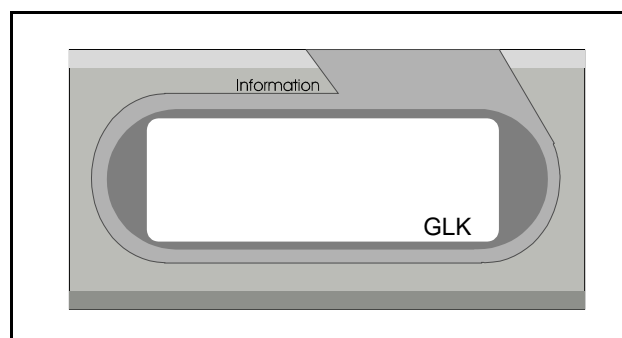
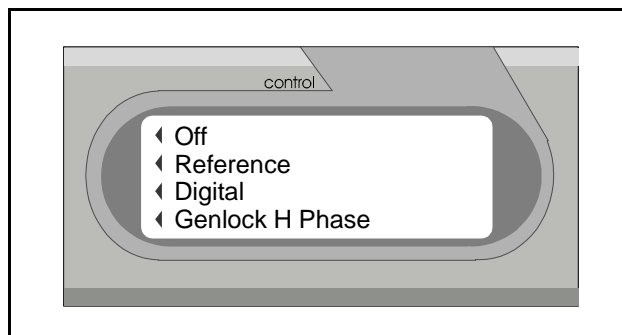

Note that these signals must be compatible with the selected Output Scan Rate; if this condition is not fulfilled a corrupted picture may be displayed. If a signal is not available at the selected reference input the information display window will indicate - - GENLOCK LOSS - -

Genlock H Phase If a fully compatible reference signal is available and the genlock mode enabled, selecting this function will reveal a bargraph showing the horizontal timing difference between the reference signal and the output signal. The timing may be adjusted using the spinwheel to give an advance or a delay of up to 1600ns.

The preset/default value is zero.

Genlock-V-Phase If a fully compatible reference signal is available and the genlock mode enabled, selecting this function will reveal a bargraph showing the vertical timing difference between the reference signal and the output signal. The timing may be adjusted using the spinwheel to give an advance or a delay of up to 4 lines.

The preset/default value is zero.

Operation

SYSTEM

Selecting **System...** in the Select Menu provides a menu listing various system parameters.

Preset Unit

This performs the same function as the PRESET dedicated front panel button. This does not clear memories.

Clear Mem

This clears data stored in all Memory locations.

VHS Mode

Turning this function ON will introduce a shorter time constant into the input sync separator phase-locked loop. This enables the input circuitry to precisely follow the timing of a jittery signal that would come from, for example, a VHS video tape playback machine that is not timebase corrected.

The function may be toggled ON or OFF.

Default is to OFF

IO Lock: Auto/Off

IO Lock forces the output scan rate to lock to the input scan rate whenever the in/out scan rates are related by a multiple or sub-multiple of each other.

For example, an output scan rate of 1250/50 will lock to an input scan rate of 625/50 (IO ratio of 1:2) but not to a SVGA 800 input scan rate (IO ratio of 1.12:1)

This function can be set to either **IO Lock: Auto** or to **IO Lock: Off** and is a system wide setting.

When in the **Auto** mode IO lock will be ON or OFF depending on whether or not the following conditions are met:

- A component input is selected (GBR/YPbPr)
- In/Out scan rates are a multiple of each other
- VHS Mode is set to OFF
- Genlocking is inactive

If any of the above conditions are not met the unit will operate in the free-run mode; i.e. not IO locked.

When in the **Off** mode the unit will *never* IO lock. This mode could be used when processing a component source which is unstable e.g. a VTR signal without timebase correction.

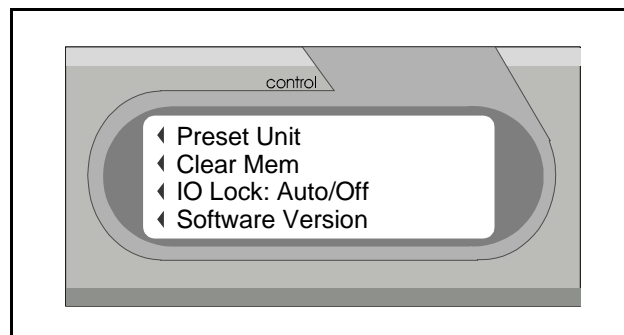

Operation

Software Version

Selecting this function will display a message in the Information window indicating the software revision. (available from version 3.1 onwards)

Unit Name

Selecting this item will display the name of this unit in the control window. This name is used in the RollCall™ system and is supplied set as 'SuperVisor'

This name may be changed by the user to an alpha-numeric string of a maximum of 14 characters including spaces.

This useful feature allows a unit to have a name more specific to an application

e.g. SVGA Processor, Projector No.1 etc.

or, in a multiple system, to ease unit identification
e.g. Top Projector, LHS Projector, Cube 1, Cube 2 etc.

When the text line is selected, the first character of will be in reversed flashing text; this character can then be changed by rotating the spinwheel. When the desired character is found the button to the left or right of the text line should be pressed and the next text character will be highlighted and available for changing. The buttons to the left and right of the text line may be used to select other characters.

To save the new text, press the OK button. It should be noted that this is the only way to save the new text as any other button function will return to another menu without modifying the original text.

Note that to remove a character and leave a clear space in the text line the **Clear** function (above Preset) should be used.

The **Preset** function returns the text to the type name of the module installed in the relevant slot.

Ver 4 Compatible

Selecting this function makes the Version 5 remote control software in this unit look like Version 4 software to enable equipment fitted with Version 4 to operate.

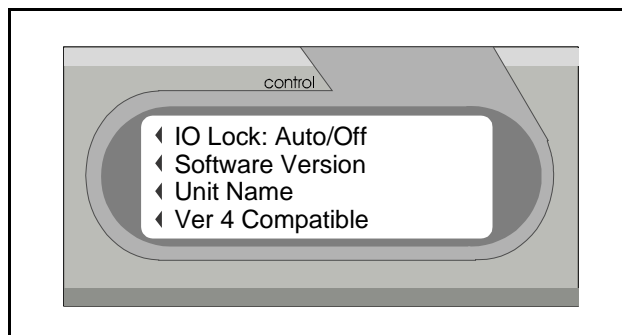

Operation

MEMORY

The SuperVisor contains a non-volatile memory that can store all settings in 5 memory locations.

Note that if SW3 position 8 is set to 'Memory Disabled', no memory functions will be available including the restoration of the power-down settings on power-up.

Selecting **Memory Save...** in the Select Menu will access a menu listing the 5 memory locations.

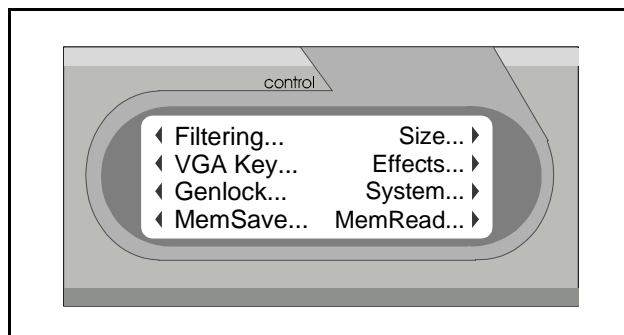

To Save the current settings, press the push button adjacent the desired memory location number.

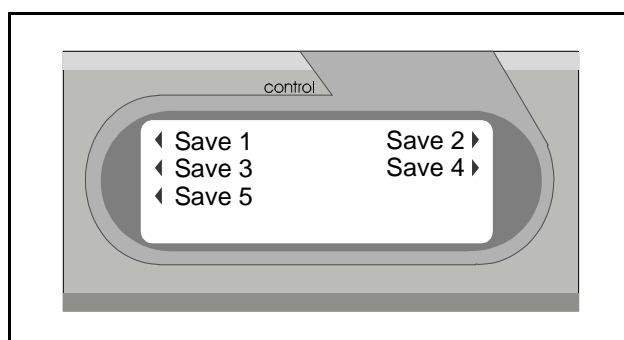

Selecting **Memory Read...** in the Select Menu will access a menu listing the 5 memory locations.

To Read the current settings, press the push button adjacent the desired memory location number.

Note that normally on power-up the settings at power-down will be automatically restored.

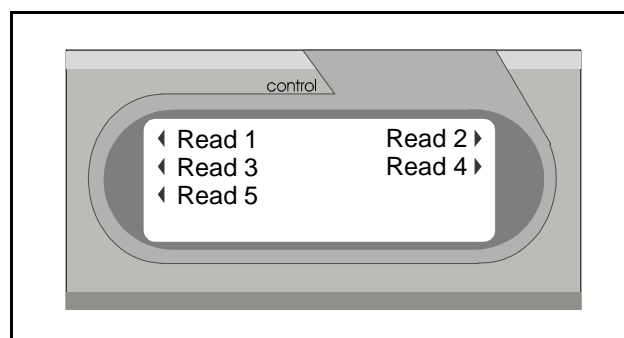

Operation

PCB MODULE CONTROLS

On the front edge of the card fitted in the unit there are a number of preset controls, indicators and switches.

To access these controls the front panel should be pulled forward and lowered.

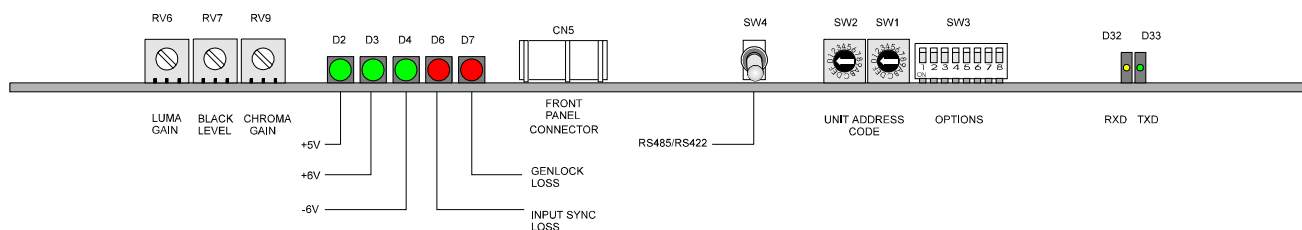

LED INDICATORS

Power Supply	+5V	Green ON=OK
	+6V	Green ON=OK
	- 6V	Green ON=OK
Input Signal Sync Loss	Red	ON=No sync, OFF=Signal Present
Genlock Signal Loss	Red	ON=No Ref signal, OFF=Ref Signal Present or 'Genlock' selected
Data Received	Yellow	
Data Transmitted	Green	

CONTROLS

RS485/422	Allows remote communication signal to be set to either RS485 (RollCall™) or RS422 (PC) Supplied set to RS422.
Unit Address Code	These Hexadecimal switches set the unit address code
Options	Various Preset options may be set using an 8-way DIP and a HEX switch

Note that the following controls ARE FACTORY CALIBRATED and should not be adjusted unless the unit is fitted with a dumb front panel and level adjustments are required.

Luma Gain	Allows Luminance gain to adjusted by $\pm 3\text{dB}$
Black Level	Allows Black Level to adjusted by $\pm 50\text{mV}$
Chroma Level	Allows Chroma Gain to adjusted by $\pm 3\text{dB}$

Operation

POWER SUPPLY INDICATORS

Three green LED indicators (D2,D3 &D4) are provided to show the status of the internal +5V, +6V and -6V power supplies.

If any of the LED's are not illuminated the unit should be switched off immediately and the unit referred to a qualified service area.

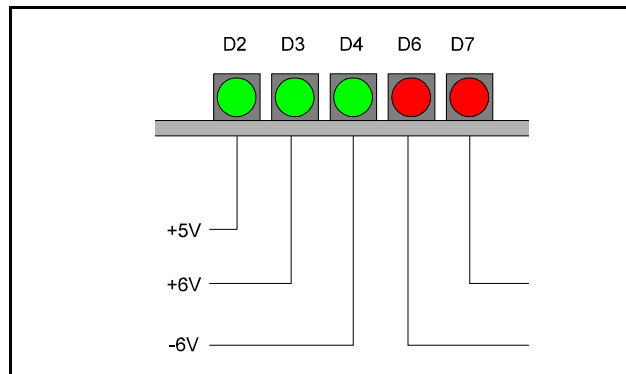

INPUT SIGNAL SYNC LOSS

This Red LED (D6) will become illuminated if the unit is not receiving an input signal at the selected input connector or if the sync level of the input signal is less than 100mV p-p

Note that under these conditions the front panel left hand display window will indicate 'Signal Loss'

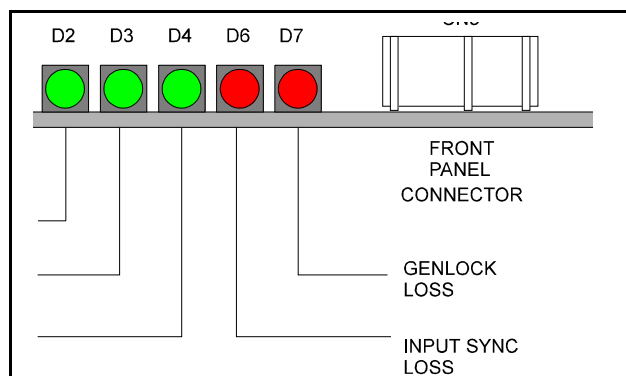

GENLOCK SIGNAL LOSS

This Red LED (D7) will become illuminated if the unit is not receiving a reference input signal at the selected genlock source connector **when the genlock function is enabled** or if the sync level of the reference input signal is less than 100mV p-p

Note that under these conditions the front panel left hand display window will indicate 'Reference Loss'

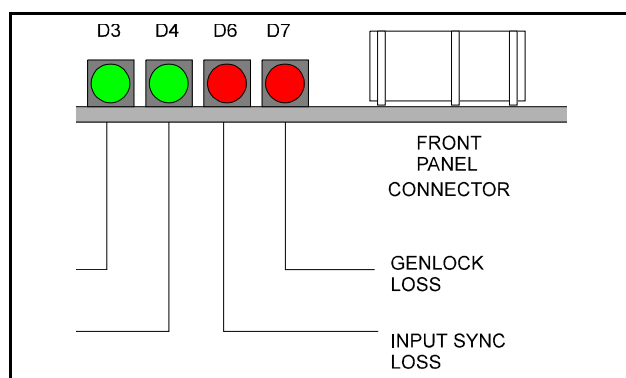

Operation

COMMUNICATIONS MODE SWITCH

The toggle switch SW1 allows the type of communication signal used for the rear panel comms 'D' connector, to be selected.

This switch should be set to the UP position for RS485 RollCall™ and DOWN for RS422 PC interface signals.

The unit is supplied with this switch set to the DOWN (RS422 PC) position.

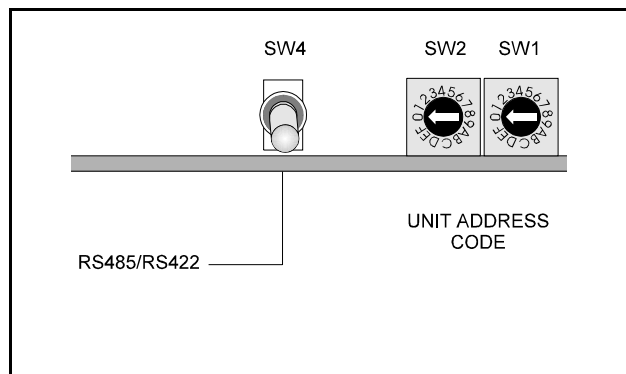

FRONT PANEL CONNECTOR

The connector CN5 is used to connect the PCB to the active front panel.

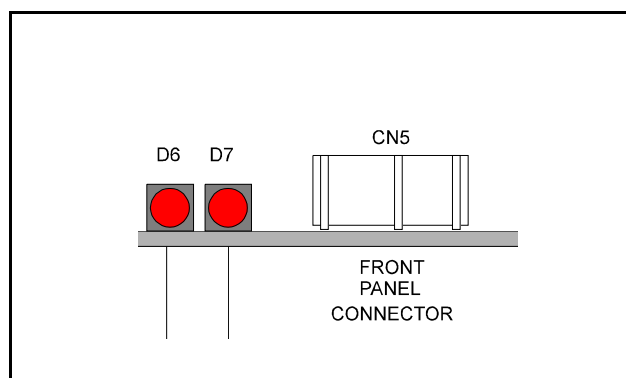

LUMA GAIN

The preset control RV6 allows the video gain of the input signal to be adjusted over the range of $\pm 3\text{dB}$.

Note that this control is factory set to 0dB and should only be used if a passive front panel is fitted and level adjustments are required.

The GAIN should be set using the main front panel controls.

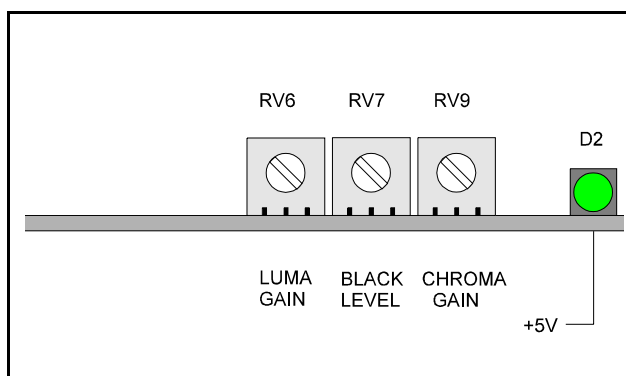

Operation

BLACK LEVEL

The preset control RV7 allows the output signal black level of the PCB module to be adjusted over the range of $\pm 50\text{mV}$.

Note that this control is factory set to 0mV and should only be used if a passive front panel is fitted and level adjustments are required.

The BLACK LEVEL should be set using the main front panel controls.

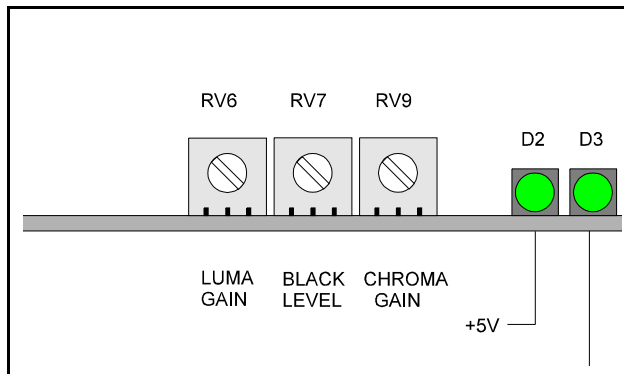

CHROMA GAIN

The preset control RV9 allows the chroma gain of the input signal to be adjusted over the range of $\pm 3\text{dB}$.

Note that this control is factory set to 0dB and should only be used if a passive front panel is fitted and level adjustments are required.

The CHROMA GAIN should be set using the main front panel controls.

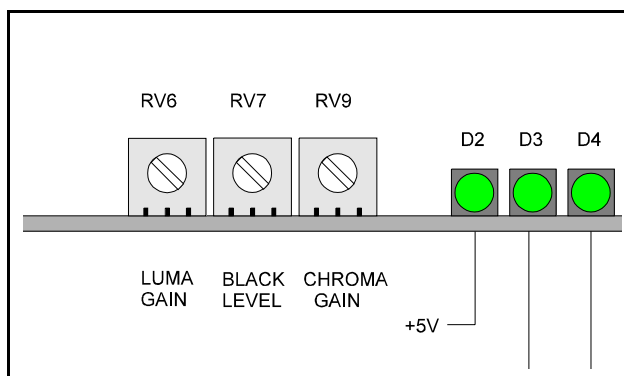

UNIT ADDRESS CODE

The HEX switches SW1 and SW2 are used to define the Unit Address code for the equipment. They are only read at power-up.

Position '0' on the SW2 will disable the RollCall™ function on the unit.

Note that if SW2 is set to '0' this will be read as '1' i.e. values '01' to '0F' will read as '11' to '1F'

The minimum address code allowable is 10_{HEX} (SW2=1, SW1=0) and is shipped with the code 14_{HEX} (SW2=1, SW1=4)

All positions above 10_{HEX} may be used to set the unit address code in Hexadecimal. (SW2, 0 to F, SW1, 0 to F)

If a code is already in use, the RollCall™ receive and transmit LED's RXD, TXD will flash alternately at a 1 second rate. The unit must then be powered-down, the code reset and the unit powered-up again.

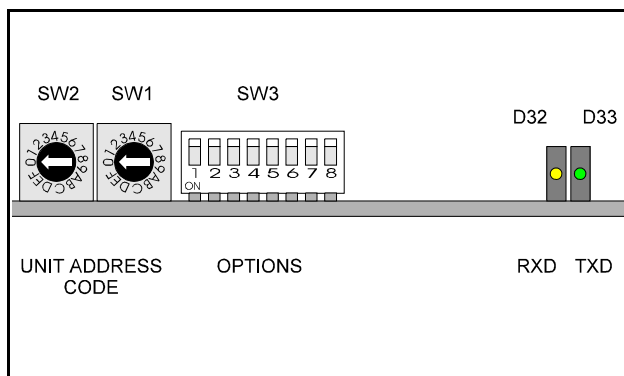

Note that in a RollCall™ segment, all units must have different unit address codes. For more information see RollCall™ Remote Control System Section 2.

Operation

OPTIONS

The DIP switch SW3 has two main functions:

- 1 The settings of this switch are read on power-up when memory function is disabled or when the preset button is pressed. When the memory is enabled previous settings will be restored on power-up.
- 2 When a passive front panel is fitted or host computer is not connected to the unit, this switch allows various functions to be enabled that would normally be set with the front panel controls or by the host computer.

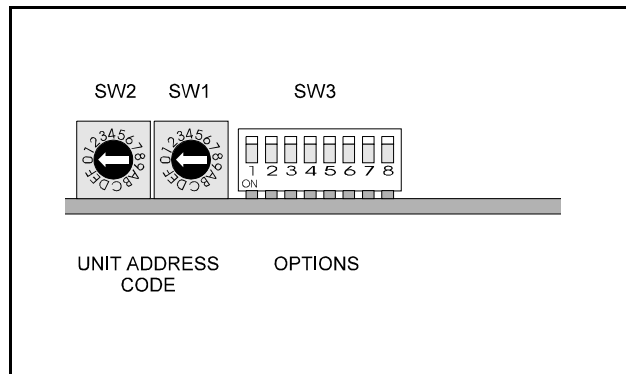

FUNCTION SELECT		SW 3 SETTINGS							
		1	2	3	4	5	6	7	8
Output Scan Rate	De-Interlaced (1:1)*	<input type="checkbox"/>	<input type="checkbox"/>						
	2x lines (2:1)*	<input type="checkbox"/>	<input type="checkbox"/>						
	2x Fields (2:1)*	<input type="checkbox"/>	<input type="checkbox"/>						
	1.5x lines, 1.5x Fields (2:1)*	<input type="checkbox"/>	<input type="checkbox"/>						
Input Format	YPbPr			<input type="checkbox"/>	<input type="checkbox"/>				
	Y-C			<input type="checkbox"/>	<input type="checkbox"/>				
	Composite			<input type="checkbox"/>	<input type="checkbox"/>				
	GBR			<input type="checkbox"/>	<input type="checkbox"/>				
Output Syncs on Green	Green Output - Syncs On				<input type="checkbox"/>				
	Green Output - Syncs Off				<input type="checkbox"/>				
Pattern	Pattern - Off					<input type="checkbox"/>	<input type="checkbox"/>		
	Pattern - Pluge					<input type="checkbox"/>	<input type="checkbox"/>		
	Pattern - Bars					<input type="checkbox"/>	<input type="checkbox"/>		
	Pattern - Crosshatch					<input type="checkbox"/>	<input type="checkbox"/>		
Memory	Memory Enabled (non-volatile)							<input type="checkbox"/>	
	Memory Disabled (non-volatile)							<input type="checkbox"/>	

* Depends on Input Scan Rate

Operation

DATA INDICATORS

The two LED indicators D32 and D33 will become illuminated when data is being received (D32) or is being transmitted (D33) to the front panel.

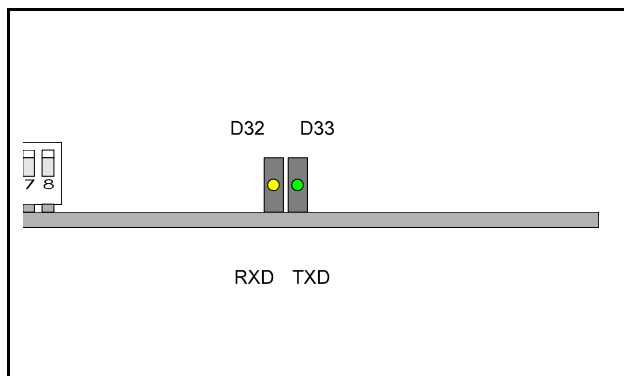

Operating the Supervisor Large Screen Optimiser from a remote controller using the RS422 interface

Version 7.x Supervisors and above.
RollCall™ 3.0 compatible

Supervisor remote control

The Supervisor unit uses RollCall™ which is a software protocol based around an RS422 interface. This document describes how to use RollCall™ to interface with a Supervisor Large Screen Optimiser.

The wiring for the cable connection from Supervisor to the RS422 on a PC is drawn on page 15.

The protocol is a binary packet stream between controller and Supervisor. Comma separators are shown in this document for clarity, but should not be included in the actual protocol. Unless otherwise indicated all numbers in this document are hexadecimal representations of 8 bit (1 BYTE) binary numbers.

Before controlling a unit, it is necessary to form a session with that unit, by way of a CONNECT command.

Then control of the unit is performed by use of the SET PARAMETER command with associated data being unit specific.

It is also possible to look at the settings of the Supervisor using the GET FUNCTION STATUS command, the reply being a RETURN FUNCTION STATUS message.

Finally once the controller no longer wishes to control the unit it can close the session with a DISCONNECT command.

These 4 commands are Rollcall™ commands, and as such should not be confused with the Supervisor specific commands which are carried in the data block of the SET PARAM command.

Reserved characters

The software protocol used is a packet based system which uses a start and end control byte to define the start and end of each packet.

CMD	Definition
0x02	Start of packet (STX)
0x03	End of packet (ETX)
0x1B	Escape character (ESC) for STX, ETX and ESC

An escape sequence is used if the start end or escape control code values are required in the packet. The escape character is inserted, and the desired character has its MSB inverted. The table below shows the 2 byte replacements.

Note that the value of the Data Length part of the packet will remain the same, since this escape character sequence is handled at a lower level.

Value required in body of Packet.	Sequence of bytes to be sent
0x02	0x1B, 0x82
0x03	0x1B, 0x83
0x1B	0x1B, 0x9B

Sending commands

The Rollcall protocol defines the format of all messages sent to the Supervisor. It consists of 4 distinct parts:

- i) The packet header consisting of the start byte, destination address, source stream and destination stream. This is constant with the exception of the Supervisors physical address.
- ii) The Rollcall command, block consisting of a data length which includes the rollcall command, the command required, (1 byte) and the command flag (1 byte). This document details four ROLLCALL commands.
- iii) The data block,. This varies dependant on which ROLLCALL command is sent, and is Supervisor specific. Use the tables at the end to fill in this section.
- iv) The packet tail consisting of a checksum (use 00 to ignore) and the stop byte.

The protocol is presented below.

In this document the packet header is shaded.	Only changed if hardware is altered.
The remote command is lightly shaded.	Data length for command + data CONNECT / TERMINATE / SET PARAM / GET FUNCTION STATUS are the four cases used in this note.
Data is left unshaded.	Every Command is different.
Packet tail is shaded.	Only changed if hardware is altered.

The only difference between commands is the command number, the length of data field and the data which is sent with the command. i.e. the packet header is the same.

Establishing a session

CONNECT

Before commands can be sent to the supervisor unit, a session needs to be set up. The way in that this is done, is to send a data packet with the CONNECT command. Here is the byte sequence.

Nominal Value	Description.
0x02	(Start Packet (STX))
0x00, 0x00, 0x14, 0x00	(Hardware specific, supervisor net address) **
0x00, 0xFF	(Supervisor stream index = Unknown)
0x00, 0x00	(Controller stream index)
0x00, 0x1B, 0x82	(Data length to follow, 2bytes + 0 [Value 02 is replaced.])
0x1B, 0x82	(RollCall™ CONNECT command [Value 02 is replaced.])
0x00	(RollCall™ command flag)
Data items	(Data items dependent on above; will be none.)
0x00	(Ignore Checksum)
0x03	(End packet (ETX))

i.e. 02 00 00 14 00 00 FF 00 00 00 1B 82 1B 82 00 00 03
Connects a session to the supervisor.

**NOTE: The value of the third byte in the hardware specific net address should be the value set on the hex switch that is located on the front of the main board of the Supervisor. If you change this switch, substitute new value in all packets. As shipped the value is 14_H

If the session is successfully set up an Acknowledge packet should be received from the Supervisor that will consist of the following sequence of bytes:

0x02		(Start Packet (STX))
	0x00, 0x00, 0x14, 0x00	(Hardware specific, supervisor net address)
	0x00, 0x00	(Supervisor stream index)
	0x00, 0x00	(Controller stream index)
	0x00, 0x1B, 0x82	(Data length to follow)
	0x01	(RollCall™ ACKNOWLEDGE command)
	0x00	(RollCall™ command flag)
	Data items	(None)
	0xCE	(Checksum)
0x03		(End packet (ETX))

i.e. 02 00 00 14 00 00 00 00 00 00 1B 82 01 00 CE 03
 Acknowledges a session start from the Supervisor

Controlling the unit

SET PARAMETER

0x02		(Start Packet (STX))
	0x00, 0x00, 0x14, 0x00	(Hardware specific, supervisor net address)
	0x00, 0x00	(Supervisor stream index)
	0x00, 0x00	(Controller stream index)
	0x00, 0x0A	(Data length, 8 bytes for SET PARAM + 2 for Rollcall cmds)
	0x10	(RollCall™ SET PARAMETER command.)
	0x00	(RollCall™ command flag)
	Data items	(6 bytes, Supervisor specific as per following tables.)
	0x00,	(Ignore checksum)
0x03		(End packet (ETX))

The *Data length* field for SET PARAM is 8 bytes, and consists of the following:

The *command number* is a word (two byte) length field which contains the number of the menu that contains the desired command. For example, command number 00 E3 means select the pedestal menu.

The *mode* is a word (two byte) length field which contains an indicator to the type of the parameter. All parameters listed in this document are of type VALUE. (Other options are STRING, DATA or WRAPPED. VALUE is indicated by 0x00 0x01.

Parameter is a long (4 byte) field, which is either the menu item that is required or a parameter value, in 2's complement. In the case of the pedestal, a parameter of 00 00 00 E4 will provide normal pedestal; a parameter of 00 00 00 E5 will remove the pedestal . Region marked *** is taken from the command tables.

REMOVE PEDESTAL		Packet
0x02		(Start Packet (STX))
	0x00, 0x00, 0x14, 0x00	(Hardware specific, supervisor net address)
	0x00, 0x00	(Supervisor stream index)
	0x00, 0x00	(Controller stream index)
	0x00, 0x0A	(Data length (2 + 8 = 10))
	0x10	(RollCall™ SET PARAMETER command)
	0x00	(RollCall™ command flag)
***	0x00, 0xE3	(Command number)
***	0x00, 0x01	(Mode number)
***	0x00,0x00,0x00,0xE5	(Parameter)
	0x00,	(Ignore checksum)
0x03		(End packet (ETX))

Actual byte sequence = 02 00 00 14 00 00 00 00 0A 10 00 00 E3 00 01 00 00 00 E5 00 03

An example of where the 2's compliment number would be used is setting the luma gain. To set luma gain to 0.2 db; the packet would read;

LUMA GAIN SET TO 0.2dB		Packet
0x02		(Start Packet (STX))
	0x00, 0x00, 0x14, 0x00	(Hardware specific, supervisor net address)
	0x00, 0x00	(Supervisor stream index)
	0x00, 0x00	(Controller stream index)
	0x00, 0x0A	(Data length)
	0x10	(RollCall™ SET PARAMETER command)
	0x00	(RollCall™ command flag)
***	0x00, 0xDD	(Command number)
***	0x00, 0x01	(Mode number)
***	0x00,0x00,0x00,0x1B,0x82	(Parameter)
	0x00,	(Ignore checksum)
0x03		(End packet (ETX))

Actual byte sequence is = 02 00 00 14 00 00 00 00 00 00 0A 10 00 00 DD 00 01 00 00 00 1B 82 00 03

After each SET PARAMETER has been sent a RETURN FUNCTION STATUS packet (see below) should be expected back from the Supervisor unit, consisting of the following bytes:

02 00 00 14 00 00 00 00 00 00 0A 0C 00 xx xx 00 01 yy yy yy yy zz 03

where:

xx = Supervisor command number.

yy = value the above is now set to

zz = packet checksum

Units status

GET FUNCTION STATUS

In order to find out the current parameters of the Supervisor, the RollCall™ Get Function Status command is required, number 0B_H.

0x02	(Start Packet (STX))
0x00, 0x00, 0x14, 0x00	(Hardware specific, supervisor net address)
0x00, 0x00	(Supervisor stream index)
0x00, 0x00	(Controller stream index)
0x00, 0x04	(Data length, 2 bytes for GET FUNCTION STATUS + 2)
0x0B	(RollCall™ GET FUNCTION STATUS command.)
0x00	(RollCall™ command flag)
Data items	(2 bytes, Supervisor specific as per tables.)
0x00,	(Ignore checksum)
0x03	(End packet (ETX))

The *Data length* field for GET FUNCTION STATUS is 2 bytes.

In this case the *command number* is a word (two byte) length field which contains the number of the menu that we want to know the status of.

The parameter or mode are not included in the GET FUNCTION STATUS packet since it is these which we want to know!

Included below are a few examples of GET FUNCTION STATUS:

	GET PEDESTRAL STATUS	Packet
0x02	(Start Packet (STX))	
0x00, 0x00, 0x14, 0x00	(Hardware specific, supervisor net address)	
0x00, 0x00	(Supervisor stream index)	
0x00, 0x00	(Controller stream index)	
0x00, 0x04	(Data length)	
0x0B	(RollCall™ GET FUNTION STATUS command)	
0x00	(RollCall™ command flag)	
***	0x00, 0xE3	(Command number)
0x00,	(Ignore checksum)	
0x03	(End packet (ETX))	

Actual byte sequence = 02 00 00 14 00 00 00 00 00 00 04 0B 00 00 E3 00 03

To get the value of the luma gain to the packet would read:

	GET LUMA GAIN	Packet
0x02	(Start Packet (STX))	
0x00, 0x00, 0x14, 0x00	(Hardware specific, supervisor net address)	
0x00, 0x00	(Supervisor stream index)	
0x00, 0x00	(Controller stream index)	
0x00, 0x04	(Data length)	
0x0B	(RollCall™ GET FUNCTION STATUS command)	
0x00	(RollCall™ GET FUNCTION STATUS command flag)	
***	0x00, 0xDD	(Command number)
0x00,	(Ignore checksum)	
0x03	(End packet (ETX))	

Actual byte sequence is = 02 00 00 14 00 00 00 00 00 00 04 0B 00 00 DD 00 03

RETURN FUNCTION STATUS

After a GET FUNCTION STATUS command has been sent a RETURN FUNCTION STATUS packet should be expected back from the Supervisor unit, instead of an Acknowledge packet. It is in a similar format to the commands:

0x02		(Start Packet (STX))
	0x00, 0x00, 0x14, 0x00	(Hardware specific, supervisor net address)
	0x00, 0x00	(Supervisor stream index)
	0x00, 0x00	(Controller stream index)
	0x00, 0x0A	(Data length, 8 bytes for RETURN FUNCT'N STATUS)
	0x0C	(RollCall™ RETURN FUNCTION STATUS command.)
	0x00	(RollCall™ command flag)
	Data items	(8 bytes, Supervisor specific as per tables.)
	0xZZ,	(Checksum)
0x03		(End packet (ETX))

The *Data length* field for RETURN FUNCTION STATUS is 8 bytes, and consists of the following:

The *command number* is included and is a word (2 byte), and should match the command number sent in the GET FUNCTION STATUS command.

The *mode* is included and is a word (2 byte), and should be 00 01 for VALUE.

The *Parameter* is a long (4 byte) field, which gives the current value of the paramter associated with the command.

The following examples show possible return packages corresponding to the previous GET FUNCTION STATUS examples:

RETURN FUNCTION STATUS's

	RETURN PEDESTAL STATUS	Packet
0x02		(Start Packet (STX))
	0x00, 0x00, 0x14, 0x00	(Hardware specific, supervisor net address)
	0x00, 0x00	(Supervisor stream index)
	0x00, 0x00	(Controller stream index)
	0x00, 0x0A	(Data length (8 + 2))
	0x0C	(RollCall™ RETURN FUNCTION STATUS command)
	0x00	(RollCall™ command flag)
***	0x00, 0xE3	(Command number)
***	0x00, 0x01	(Mode = value)
***	0x00,0x00,0x00,0xE5	(Parameter)
	0x8D,	(Checksum)
0x03		(End packet (ETX))

Actual byte sequence = 02 00 00 14 00 00 00 00 00 00 0A 0C 00 00 E3 00 01 00 00 00 E5 8D 03
(Pedestal is being removed)

Again 2's compliment is used to read parameters with actual values, as shown below.

LUMA GAIN STATUS		Packet
0x02		(Start Packet (STX))
	0x00, 0x00, 0x14, 0x00	(Hardware specific, supervisor net address)
	0x00, 0x00	(Supervisor stream index)
	0x00, 0x00	(Controller stream index)
	0x00, 0x0A	(Data length (8 + 2))
	0x0C	(RollCall™ RETURN FUNCTION STATUS command)
	0x00	(RollCall™ command flag)
***	0x00, 0xDD	(Command number)
***	0x00, 0x01	(Mode = value)
***	0x00,0x00,0x00,0x1B,0x82	(Parameter)
	0xDB,	(Checksum)
0x03		(End packet (ETX))

Actual byte sequence is = 02 00 00 14 00 00 00 00 00 00 0A 0C 00 00 DD 00 01 00 00 00 1B 82 DB 03
(Luma gain is set to 0.2dB)

Ending a session

DISCONNECT

When a program has stopped communicating with the Supervisor a disconnect session packet should be sent. (This is a rare event since usually a controller will stay in session permanently) This packet consists of the following sequence of bytes:

DISCONNECT SESSION		Packet
0x02		(Start Packet (STX))
	0x00, 0x00, 0x14, 0x00	(Hardware specific, supervisor net address) **
	0x00, 0x00	(Destination stream)
	0x00, 0x00	(Source stream)
	0x00, 0x1B, 0x82	(Data length, 2 bytes [Value 02 is replaced.])
	0x1B, 0x83	(RollCall™ DISCONNECT command [Value 03 is replaced.])
	0x00	(RollCall™ command flag)
	0x00,	(Ignore checksum)
0x03		(End packet (ETX))

Actual sequence is = 02 00 00 14 00 00 00 00 00 1B 83 00 00 00 00 03

If the session is successfully terminated, an Acknowledge packet should be expected back from the Supervisor unit.

02 00 00 14 00 00 00 00 00 00 1B 82 01 00 00 03
Acknowledge from the Supervisor

Example Session

All bytes in **bold** are sent to supervisor; all bytes in small text are from Supervisor.

A session with the Supervisor unit should be initiated with the following packet

02, 00, 00, 14, 00, 00, 7F, 00, 00, 1B, 82, 00, 00, 00, 00, 03

Connects a session to the Supervisor.

An Acknowledge packet will be expected back consisting of the following bytes

02, 00, 00, 14, 00, 00, 00, 00, 00, 00, 1B, 82, 01, 00, CE, 03

Acknowledge from the Supervisor.

Change Luma Gain to -3dB

02, 00, 00, 14, 00, 00, 00, 00, 00, 00, 0A, 10, 00, 00, DD, 00, 01, FF, FF, FF, E2, 00, 03

Select Luma Gain to -3dB

02, 00, 00, 14, 00, 00, 00, 00, 00, 00, 0A, 0C, 00, 00, DD, 00, 01, FF, FF, FF, E2, 99, 03

Acknowledge from the Supervisor.

Change Luma Gain to +3dB

02, 00, 00, 14, 00, 00, 00, 00, 00, 00, 0A, 10, 00, 00, DD, 00, 01, 00, 00, 00, 1E, 00, 03

Select Luma Gain to +3dB

02, 00, 00, 14, 00, 00, 00, 00, 00, 00, 0A, 0C, 00, 00, DD, 00, 01, 00, 00, 00, 1E, DA, 03

Acknowledge from the Supervisor.

The next sequence of bytes should set Pattern Generation on.

02, 00, 00, 14, 00, 00, 00, 00, 00, 00, 0A, 10, 00, 00, 80, 00, 01, 00, 00, 00, 01, 00, 03

Set Pattern Generation On.

02, 00, 00, 14, 00, 00, 00, 00, 00, 00, 0A, 0C, 00, 00, 80, 00, 01, 00, 00, 00, 01, D4, 03

Acknowledge from the Supervisor.

The next sequence of bytes should set Pattern Generation Off.

02, 00, 00, 14, 00, 00, 00, 00, 00, 00, 0A, 10, 00, 00, 80, 00, 01, 00, 00, 00, 00, 00, 03

Set Pattern Generation Off.

02, 00, 00, 14, 00, 00, 00, 00, 00, 00, 0A, 0C, 00, 00, 80, 00, 01, 00, 00, 00, 00, D5, 03
Acknowledge from the Supervisor.

Change Aspect Ratio to 16:9- 4:3 Letterbox

02, 00, 00, 14, 00, 00, 00, 00, 00, 0A, 10, 00, 01, 18, 00, 01, 00, 00, 01, 1B, 9B, 00, 03 ***

Select Aspect Ratio to 16:9- 4:3 Letterbox

02, 00, 00, 14, 00, 00, 00, 00, 00, 0A, 0C, 00, 01, 18, 00, 01, 00, 00, 01, 1B, 9B, 85, 03
Acknowledge from the Supervisor.

*** Note that the data length 00 0A does not change even though the escape sequence is used.

Change Aspect Ratio to Normal

02, 00, 00, 14, 00, 00, 00, 00, 00, 0A, 10, 00, 01, 18, 00, 01, 00, 00, 01, 19, 00, 03

Select aspect ratio to 16:9- 4:3 Letterbox

02, 00, 00, 14, 00, 00, 00, 00, 00, 0A, 0C, 00, 01, 18, 00, 01, 00, 00, 01, 19, A2, 03
Acknowledge from the Supervisor.

Identify Luma Gain Value

02, 00, 00, 14, 00, 00, 00, 00, 00, 04, 0B, 00, 00, DD, 00, 03

Get Function Status on Luma Gain

02, 00, 00, 14, 00, 00, 00, 00, 00, 0A, 0C, 00, 00, DD, 00, 01, 00, 00, 00, 1E, DA, 03

Return Function Status from the Supervisor.

Luma Gain is +3dB

Identify Pattern Generation Status

02, 00, 00, 14, 00, 00, 00, 00, 00, 04, 0B, 00, 00, 80, 00, 03

Get Function Status on Pattern Generation

02, 00, 00, 14, 00, 00, 00, 00, 00, 0A, 0C, 00, 00, 80, 00, 01, 00, 00, 00, 00, D5, 03

Return Function Status from the Supervisor.

Pattern Off

Identify Aspect Ratio Status

02, 00, 00, 14, 00, 00, 00, 00, 00, 04, 0B, 00, 01, 18, 00, 03

Get Function Status on Aspect Ratio

02, 00, 00, 14, 00, 00, 00, 00, 00, 0A, 0C, 00, 01, 18, 00, 01, 00, 00, 01, 19, A2, 03

Return Function Status from the Supervisor.

Normal Aspect

When a program has finished the following disconnect session packet should be sent

02, 00, 00, 14, 00, 00, 00, 00, 00, 1B, 82, 1B, 83, 00, 00, 03

Disconnects a session to the Supervisor.

02, 00, 00, 14, 00, 00, 00, 00, 00, 1B, 82, 01, 00, CE, 03

Acknowledge from the Supervisor

Tables to show the commands of the Supervisor

The *Scale and unit* field signifies the amount that the parameter sent with a command is multiplied by. For example when the Luma Gain is being set, a value between -30 and +30 is sent which is then multiplied by 0.1 to give an actual value of -3 to +3 which has the unit dB. The numbers are decimal in this column.

The Step unit indicates the amount by which parameters sent with a command can be stepped by. For example the Horizontal picture size command has a range of acceptable values between 170 and 560 and should be stepped in units of 10. This means that values like 175 and 195 are not acceptable. This numbers in this column are decimal.

Note: commands without a parameter field expect a number to be sent to set the actual value of the parameter. For example the Luma gain command which expects the required value of the Luma gain to be sent to the unit. The format of the numbers to be sent is 2's complement 4 byte to allow negative numbers to be sent. For commands where the range goes from negative to positive, the negative numbers can be expressed by using binary twos complement. If the default setting for a command such as Luma gain is required the value to send is Max Value + 1.

Menu item	Function name	Notes	Data length	Command number	Parameter
Output	625 100 2:1	625 100 Output	00 06	00 C9	00 00 00 6F
Output	625 50 1:1	625 1:1 Output	00 06	00 C9	00 00 00 70
Output	1250 50 2:1	1250 HD Output	00 06	00 C9	00 00 00 7B
Output	875 75 2:1	875 75Hz 2:1 Output	00 06	00 C9	00 00 00 71
Output	525 120 2:1	525 120 Output	00 06	00 C9	00 00 00 73
Output	525 60 1:1	525 1:1 Output	00 06	00 C9	00 00 00 74
Output	1050 60 2:1	1050 HD Output	00 06	00 C9	00 00 00 79
Output	735 60 1:1	735 60 1:1 Output	00 06	00 C9	00 00 00 81
Output	735 90 2:1	735 90 2:1 Output	00 06	00 C9	00 00 00 75
Output	1125 60 2:1	1125 HD Output	00 06	00 C9	00 00 00 7A
Output	VGA 320x400 1:1	CGA Output	00 06	00 C9	00 00 00 76
Output	VGA 640x480 1:1	VGA Output	00 06	00 C9	00 00 00 77
Output	VGA 800x600 1:1	SVGA Output	00 06	00 C9	00 00 00 78
Output	Mac 640x480 1:1	Mac Output	00 06	00 C9	00 00 00 7E
Output	Mac 832x624 1:1	Mac Output	00 06	00 C9	00 00 00 7F
Output	Eidophor Europe	Eidophor Output	00 06	00 C9	00 00 00 7C
Output	Eidophor US	Eidophor Output	00 06	00 C9	00 00 00 7D

Menu item	Function name	Notes	Data Length	Command number	Parameter
Output Format	YPbPr	YPbPr output format	00 06	00 00	00 00 00 00
Output Format	GBR	GBR output format	00 06	00 00	00 00 00 01
Output Sync	Norm	Sync +	00 06	00 83	00 00 00 00
Output Sync	Invert	Sync -	00 06	00 83	00 00 00 01
Output Sync	Off	No sync on G/Y	00 06	00 85	00 00 00 00
Output Sync	On	Sync on G/Y	00 06	00 85	00 00 00 01
Output Sync	Comp Sync Off	Separate H & V	00 06	00 87	00 00 00 00
Output Sync	Comp Sync On	Combined H & V	00 06	00 87	00 00 00 01

NOTE:-

Eidophor outputs are optional and are not available on all units.

Menu item	Function name	Notes	Data length	Command number	Parameter
Input Type	YPbPr	YPbPr input	00 06	00 81	00 00 00 0C
Input Type	GBR	GBR input	00 06	00 81	00 00 00 00
Input Type	YC	YC input	00 06	00 81	00 00 00 04
Input Type	Composite	Composite input	00 06	00 81	00 00 00 08
Input Type	VGA	VGA input	00 06	00 81	00 00 00 0E

Menu item	Function name	Notes	Data Length	Command Number	Parameter
Insync	Sync on G/Y	Input Sync on G/Y	00 06	00 CA	00 00 00 D0
Insync	Ext 0.3V Syncs	Input Sync on external 0.3 Syncs	00 06	00 CA	00 00 00 D1
Insync	Ext 2.0V Syncs	Input Sync on external 2.0V Syncs	00 06	00 CA	00 00 00 D2
Insync	Ext HD Syncs	Input Syncs on external HD Syncs	00 06	00 CA	00 00 00 D3

Menu item	Function name	Notes	Data length	Command number	Parameter
Input	Auto	Auto std detect for input	00 06	00 C8	00 00 00 65
Input	625 50 2:1	625 Input	00 06	00 C8	00 00 00 66
Input	525 60 2:1	525 Input	00 06	00 C8	00 00 00 67
Input	CGA 320x400 1:1	CGA Input	00 06	00 C8	00 00 00 68
Input	VGA 640x480 1:1	VGA Input	00 06	00 C8	00 00 00 69
Input	SVGA 800x600 1:1	SVGA Input	00 06	00 C8	00 00 00 6A
Input	1250 50 2:1	1250 Input	00 06	00 C8	00 00 00 6B
Input	1125 60 2:1	1125 Input	00 06	00 C8	00 00 00 6C
Input	1050 60 2:1	1050 Input	00 06	00 C8	00 00 00 6D
Input	Mac 832x624 1:1	Mac Input	00 06	00 C8	00 00 00 6B

NOTE:-

HD inputs are optional and not available on all units.

Menu item	Function name	Notes	Data Length	Command number	Parameter
Pattern Menu	100% Bars	Select 100% Bars	00 06	00 E6	00 00 00 0A
Pattern Menu	Bars & Red	Select Bars & Red	00 06	00 E6	00 00 00 0B
Pattern Menu	Cross Hatch	Select Cross Hatch	00 06	00 E6	00 00 00 0C
Pattern Menu	Step (Gamma)	Select Gamma Step	00 06	00 E6	00 00 00 0D
Pattern Menu	Ramp	Select Ramp	00 06	00 E6	00 00 00 0E
Pattern Menu	M-Burst	Select M-Burst	00 06	00 E6	00 00 00 0F
Pattern Menu	Pluge	Select Pluge	00 06	00 E6	00 00 00 10
Pattern Menu	Black	Select Black	00 06	00 E6	00 00 00 11
Pattern Menu	White	Select White	00 06	00 E6	00 00 00 12
Pattern Menu	Pattern On	Turn pattern on	00 06	00 80	00 00 00 01
Pattern Menu	Pattern Off	Turn pattern off	00 06	00 80	00 00 00 00

Menu item	Function name	Notes	Data Length	Command number	Parameter Min value	Max value	Scale and unit	Step
Analogue Control.	Luma Gain	Select Luma Gain	00 06 *	00 DD	FF FF FF E2	00 00 00 1E	0.1 (dB)	1
Analogue Control	Chroma Gain	Select Chroma Gain	00 06 *	00 DE	FF FF FF E2	00 00 00 1E	0.1 (dB)	1
Analogue Control	Black Level	Select Black Level	00 06 *	00 DF	FF FF FF CE	00 00 00 32	1 (mV)	1

* The data length will be 00 0A even if parameter required is 0x02, 0x03 or 0x1B.

Menu item	Function name	Notes	Data Length	Command number	Parameter
Pedestal	Pedestal Normal	No Pedestal	00 06	00 E3	00 00 00 E4
Pedestal	Pedestal Remove	Remove Pedestal	00 06	00 E3	00 00 00 E5

Menu item	Function name	Notes	Data Length	Command number	Min value	Max value	Scale and unit	Step
Hue	NTSC Hue	NTSC Hue	00 06 *	00 E0	FF FF FF EC	00 00 00 14	1 (deg)	2
YC_H	YC delay (H)	Horizontal Y/C delay	00 06 *	00 E1	FF FF FF F0	00 00 00 10	1	1
YC_V	YC delay (V)	Vertical Y/C delay	00 06 *	00 E2	FF FF FF F8	00 00 00 08	1	2
Henh	Horiz Sharp	Horizontal Sharpening	00 06 *	00 FD	00 00 00 00	00 00 00 5A	0.1(dB)	1E
Venh	Vert Sharp	Vertical Sharpening	00 06 *	00 FC	00 00 00 00	00 00 00 5A	0.1(dB)	1E
Gamma	Gamma	Gamma select	00 06 *	00 FE	00 00 00 00	00 00 00 09	1	1
Horizsize	Horiz size	Horizontal size	00 06 +*	00 D4	FF FF FF 80	00 00 07 9C	1	10
Vertsize	Vert size	Vertical size	00 06	00 D5	FF FF FF F6	00 00 00 B4	0.5	1
Horizpan	Pan	Horizontal Pan	00 06 *	00 D7	00 00 00 00	00 00 00 C8	1	1
Vertilt	Tilt	Vertical tilt	00 06 *	00 D6	00 00 00 00	00 00 00 C8	1	1

Menu item	Function name	Notes	Data Length	Command number	Parameter
Aspect ratio	Normal	Normal Aspect	00 06	01 18	00 00 01 19
Aspect ratio	16:9-4:3	16:9-4:3 Side Crop	00 06	01 18	00 00 01 1A
Aspect ratio	16:9-4:3	16:9-4:3 Letterbox	00 06	01 18	00 00 01 1B
Aspect ratio	4:3-16:9	4:3-16:9 Curtain	00 06	01 18	00 00 01 1C
Aspect ratio	4:3-16:9	4:3-16:9 Top Crop	00 06	01 18	00 00 01 1D

Menu item	Function name	Notes	Data Length	Command number	Parameter	Min value	Max value	Scale	Step
VGA Options	Wipe	VGA Wipe select	00 06	01 09	00 00 00 00				
VGA Options	Key	VGA Key select	00 06	01 09	00 00 00 00				
VGA Threshold	Key Threshold	VGA Key Threshold	00 06 *	01 0B		00 00 00 00	00 00 00 3F	1	1
Horiz wipe point	H Wipe Adjust	VGA Horiz Wipe Point	00 06 +*	01 0D		00 00 00 00	00 00 01 F4	1	1
Vert wipe point	V Wipe Adjust	VGA Vert Wipe Point	00 06 +*	01 0C		00 00 00 00	00 00 02 58	1	1
Horiz wipe invert on	H wipe invert	Inversion Activate	00 06	01 06	00 00 00 01				
Horiz wipe invert off	H wipe norm	Inversion off.	00 06	01 06	00 00 00 00				
Vert wipe invert on	V wipe invert	Inversion Activate	00 06	01 12	00 00 00 01				
Vert wipe invert off	V wipe norm	Inversion off.	00 06	01 12	00 00 00 00				
Total key Invert on	Key signal invert	Inversion Activate	00 06	01 07	00 00 00 01				
Total key Invert off	Key signal norm	Inversion off.	00 06	01 07	00 00 00 00				
VGA key on	Key active	VGA key Activate	00 06	01 08	00 00 00 01				
VGA key off	Key inactive	VGA Key off	00 06	01 08	00 00 00 00				

Menu item	Function name	Notes	Data Length	Command number	Parameter
Effects	Freeze	Freeze on	00 06	01 0F	00 00 00 01
Effects	Freeze	Freeze off	00 06	01 0F	00 00 00 00
Effects	Mono	Mono on	00 06	01 10	00 00 00 01
Effects	Mono	Mono off	00 06	01 10	00 00 00 00
Effects	Invert	Invert on	00 06	01 11	00 00 00 01
Effects	Invert	Invert off	00 06	01 11	00 00 00 00

* The data length will be 00 0A even if parameter required is 0x02, 0x03 or 0x1B.

NOTE:-

Horizontal VGA wipe is only available from version 6.0 software onwards. In version 5.x Total key invert is used instead of Vert wipe invert

Menu item	Function name	Notes	Data Length	Command number	Parameter
Wall Select	Wall 1H x 2V	Video Wall shape	00 06	01 54	00 00 01 55
Wall Select	Wall 1H x 3V	Video Wall shape	00 06	01 54	00 00 01 56
Wall Select	Wall 1H x 4V	Video Wall shape	00 06	01 54	00 00 01 57
Wall Select	Wall 2H x 1V	Video Wall shape	00 06	01 54	00 00 01 58
Wall Select	Wall 2H x 2V	Video Wall shape	00 06	01 54	00 00 01 59
Wall Select	Wall 2H x 3V	Video Wall shape	00 06	01 54	00 00 01 5A
Wall Select	Wall 2H x 4V	Video Wall shape	00 06	01 54	00 00 01 5B
Wall Select	Wall 3H x 1V	Video Wall shape	00 06	01 54	00 00 01 5C
Wall Select	Wall 3H x 2V	Video Wall shape	00 06	01 54	00 00 01 5D
Wall Select	Wall 3H x 3V	Video Wall shape	00 06	01 54	00 00 01 5E
Wall Select	Wall 3H x 4V	Video Wall shape	00 06	01 54	00 00 01 5F
Wall Select	Wall 4H x 1V	Video Wall shape	00 06	01 54	00 00 01 60
Wall Select	Wall 4H x 2V	Video Wall shape	00 06	01 54	00 00 01 61
Wall Select	Wall 4H x 3V	Video Wall shape	00 06	01 54	00 00 01 62
Wall Select	Wall 4H x 4V	Video Wall shape	00 06	01 54	00 00 01 63

Menu item	Function name	Notes	Data Length	Command number	Min value	Max value	Scale	Step
Cube Select	Cube Select	Select video wall cube	00 06 *	01 68	00 00 00 00	00 00 00 10	1	1

Menu item	Function name	Notes	Data Length	Command number	Parameter
Genlock Menu	Off	Genlock Off	00 06	01 22	00 00 00 5B
Genlock Menu	Reference	Reference Genlock On	00 06	01 22	00 00 00 5C
Genlock Menu	Digital	Digital Genlock On	00 06	01 22	00 00 00 5D

Menu item	Function name	Notes	Data Length	Command number	Min value	Max value	Scale	Step
Genlock	H Phase	Genlock H Phase	00 06 *	00 5E	00 00 00 00	00 00 00 7F	1	1
Genlock	V Phase	Genlock V Phase	00 06 *	00 5F	FF FF FF FC	00 00 00 04	1	1

Menu item	Function name	Notes	Data Length	Command number	Parameter
System	Preset Unit	Return unit to Presets	00 06	01 3D	00 00 00 00
System	Clear Mem	Clear memories	00 06	01 34	00 00 00 01
System	VHS Mode	VHS mode PLL off	00 06	01 30	00 00 00 00
System	VHS Mode	VHS mode PLL on	00 06	01 30	00 00 00 01
System	IO Lock	IO Lock off	00 06	01 31	00 00 00 00
System	IO Lock	IO Lock auto	00 06	01 31	00 00 00 02

Menu item	Function name	Notes	Data Length	Command number	Parameter
Save Menu	Save 1	Save to memory 1	00 06	01 40	00 00 01 41
Save Menu	Save 2	Save to memory 2	00 06	01 40	00 00 01 42
Save Menu	Save 3	Save to memory 3	00 06	01 40	00 00 01 43
Save Menu	Save 4	Save to memory 4	00 06	01 40	00 00 01 44
Save MenU	Save 5	Save to memory 5	00 06	01 40	00 00 01 45

Menu item	Function name	Notes	Data Length	Command number	Parameter
Recall Menu	Read 1	Read memory 1	00 06	01 4A	00 00 01 41
Recall Menu	Read 2	Read memory 2	00 06	01 4A	00 00 01 42
Recall Menu	Read 3	Read memory 3	00 06	01 4A	00 00 01 43
Recall Menu	Read 4	Read memory 4	00 06	01 4A	00 00 01 44
Recall Menu	Read 5	Read memory 5	00 06	01 4A	00 00 01 45

* The data length will be 00 0A even if parameter required is 0x02, 0x03 or 0x1B.

Wiring for SuperVisor RS422 Interface to PC RS422 Interface

Baud Rate: 38 400
 Parity: None
 Data: 8 Bits
 Stop Bits: 1

PC End
 RS422 on PC

SuperVisor End

Tx +ve (A)		7 Tx +ve
Tx -ve (B)		2 Tx -ve
Rx +ve (A)		3 Rx +ve
Rx -ve (B)		8 Rx -ve
Ground		6 Ground **

Note:

Do not connect to any other pins on the SuperVisor 9 way D-type connector

**Ground is on pins 1, 4, 6 & 9. Connect to any one of these pins.

Pin 5 is power and no connection should be made to this pin.